

Board of Education Regular Meeting

Monday, May 12, 2025 8:00 PM

Board Room, 1301 Centennial Avenue, Utica, NE 68456-0187

Bryce Borchers: Present
Doug Cast: Present
Cole Henderson: Present
Lana Hoffschneider: Present
Jason Richters: Present
Derek Tomes: Present

1. MEETING CALL TO ORDER	Speaker (s) : Board President
1.1. Reading of Public Meeting Notice	Speaker (s) : Board President
1.1.1. Open Meetings Act	Speaker (s) : Board President
1.2. Roll Call	Speaker (s) : President Richters
1.2.1. Action to Excuse Board Member(s) if Necessary	Speaker (s) : President Richters
1.3. Centennial Public School Mission Statement: Empower, Challenge, and Support Every Student, Every Day.	
1.4. Pledge of Allegiance	Speaker (s) : President Richters
1.5. Consent Agenda Action(s) : Motion to approve the consent agenda as presented Passed with a motion by Lana Hoffschneider and a second by Derek Tomes. Voting Detail: Bryce Borchers: Yea Doug Cast: Yea Cole Henderson: Yea Lana Hoffschneider: Yea Jason Richters: Yea Derek Tomes: Yea Voting Summary: Yea: 6, Nay: 0	Speaker (s) : President Richters
1.5.1. Consider Minutes of Previous Meeting and Their Approval	Speaker (s) : Board President
1.5.2. Consider General Fund, Building Fund, and Activity Fund Bills and Their Approval	Speaker (s) : Board President
1.5.3. Consider Activity Accounts and Treasurer's Report	Speaker (s) : Board President
1.6. Public Forum	Speaker (s) : Board President
1.6.1. Public forum: This is an opportunity for members of the public to speak to items on the agenda or items of concern to the public. If you are not part of the presentation of an agenda item, you need to speak now. Thank you for your	Speaker (s) : Board President

participation.

2. ACTION ITEMS

Speaker (s) : Board President

2.1. DISCUSS, REVIEW, AND CONSIDER MEAL PRICES FOR THE 2025-2026 SCHOOL YEAR

Speaker (s) : SUPT. FORD

Action(s) :

Motion to approve meal prices for 2025-2026 as presented Passed with a motion by Bryce Borchers and a second by Cole Henderson.

Voting Detail:

Bryce Borchers: Yea
Doug Cast: Yea
Cole Henderson: Yea
Lana Hoffschneider: Yea
Jason Richters: Yea
Derek Tomes: Yea

Voting Summary: Yea: 6, Nay: 0

2.2. DISCUSS, REVIEW, AND CONSIDER APPROVAL OF POLICIES 3023-3032 AND 3014

Speaker (s) : SUPT. FORD

Action(s) :

Motion to review and approve policies 3023-3032 with recommended updates to 3014 and 3028 Passed with a motion by Derek Tomes and a second by Lana Hoffschneider.

Voting Detail:

Bryce Borchers: Yea
Doug Cast: Yea
Cole Henderson: Yea
Lana Hoffschneider: Yea
Jason Richters: Yea
Derek Tomes: Yea

Voting Summary: Yea: 6, Nay: 0

2.3. DISCUSS, REVIEW, AND CONSIDER ACTIVITY PRICES FOR THE 2025-2026 SCHOOL YEAR

Speaker (s) : SUPT. FORD

Action(s) :

Motion to approve 2025-2026 activity admission prices as presented Passed with a motion by Cole Henderson and a second by Derek Tomes.

Voting Detail:

Bryce Borchers: Yea
Doug Cast: Yea
Cole Henderson: Yea
Lana Hoffschneider: Yea
Jason Richters: Yea
Derek Tomes: Yea

Voting Summary: Yea: 6, Nay: 0

2.4. DISCUSS, REVIEW, AND CONSIDER GRADUATION REQUIREMENTS FOR THE 2025-2026 SCHOOL YEAR

2.5. DISCUSS, REVIEW, AND CONSIDER BID FOR COOKING RANGE EXHAUST IN FCS CLASSROOM

Speaker (s) : SUPT. FORD

Action(s) :

Motion to accept the bid from McCormick's Heating

and Air Conditioning as presented Passed with a motion by Lana Hoffschneider and a second by Bryce Borchers.

Voting Detail:

Bryce Borchers: Yea
Doug Cast: Yea
Cole Henderson: Yea
Lana Hoffschneider: Yea
Jason Richters: Yea
Derek Tomes: Yea

Voting Summary: Yea: 6, Nay: 0

2.6. DISCUSS, REVIEW, AND CONSIDER ACCEPTANCE OF RESIGNATION(S) (IF NEEDED) **Speaker (s):** SUPT. FORD

2.7. DISCUSS, REVIEW, AND CONSIDER APPROVAL OF NEW HIRES **Speaker (s):** SUPT. FORD

Action(s):

Motion to approve the contracts of Jack Hedke (Social Studies) and Arne Anderson (Ag/STS) for the 2025-2026 school year Passed with a motion by Jason Richters and a second by Doug Cast.

Voting Detail:

Bryce Borchers: Yea
Doug Cast: Yea
Cole Henderson: Yea
Lana Hoffschneider: Yea
Jason Richters: Yea
Derek Tomes: Yea

Voting Summary: Yea: 6, Nay: 0

3. **DISCUSSION ITEMS** **Speaker (s):** Board President

3.1. REVIEW DRAFT ANNUAL REPORT

3.2. REVISION GRANT UPDATE

3.3. SUPERINTENDENT'S REPORT

3.4. BOARD RETREAT PLANNING

3.5. STUDENT RECOGNITION

3.6. REIMBURSEMENT RATES 2025-2026

3.7. FBLA STUDENT PRESENTATION

4. **ADJOURN** **Speaker (s):** Board President

Action(s):

Motion to adjourn at 8:55pm Passed with a motion by Doug Cast and a second by Derek Tomes.

Voting Detail:

Bryce Borchers: Yea
Doug Cast: Yea
Cole Henderson: Yea

Lana Hoffschneider: Yea
Jason Richters: Yea
Derek Tomes: Yea
Voting Summary: Yea: 6, Nay: 0

Board Secretary

York News-Times



Publication Name:

York News-Times

Publication URL:

www.yorknewstimes.com

Publication City and State:

York, NE

Publication County:

York

Notice Popular Keyword Category:

Notice Keywords:

centennial

Notice Authentication Number:

202505051614134557533

2726237997

Notice URL:

[Back](#)

Notice Publish Date:

Saturday, April 26, 2025

Notice Content

Notice is hereby given that a meeting of the Board of Education of Centennial Public School, District 67-R, will be held at 8:00 p.m. on the 12th day of May, 2025, in the Board of Education Room of the Centennial School, Utica, NE, which meeting will be open to the public. An agenda, kept continuously current, is available for public inspection on the school website and at the office of the superintendent. By: Derek Tomes, Secretary Centennial Board of Education April 26, 2025 COL-NE-1600521 ZNEZ

[Back](#)

Board of Education Regular Meeting

Monday, April 14, 2025 8:00 PM

Board Room, 1301 Centennial Avenue, Utica, NE 68456-0187

Bryce Borchers: Present
Doug Cast: Present
Cole Henderson: Present
Lana Hoffschneider: Present
Jason Richters: Present
Derek Tomes: Present

1. MEETING CALL TO ORDER	Speaker (s) : Board President
1.1. Reading of Public Meeting Notice	Speaker (s) : Board President
1.1.1. Open Meetings Act	Speaker (s) : Board President
1.2. Roll Call	Speaker (s) : President Richters
1.2.1. Action to Excuse Board Member(s) if Necessary	Speaker (s) : President Richters
1.3. Centennial Public School Mission Statement: Empower, Challenge, and Support Every Student, Every Day.	
1.4. Pledge of Allegiance	Speaker (s) : President Richters
1.5. Consent Agenda Action(s) : Motion to approve consent agenda as presented Passed with a motion by Doug Cast and a second by Derek Tomes. Voting Detail: Bryce Borchers: Yea Doug Cast: Yea Cole Henderson: Yea Lana Hoffschneider: Yea Jason Richters: Yea Derek Tomes: Yea Voting Summary: Yea: 6, Nay: 0	Speaker (s) : President Richters
1.5.1. Consider Minutes of Previous Meeting and Their Approval	Speaker (s) : Board President
1.5.2. Consider General Fund, Buiding Fund and Activity Fund Bills and Their Approval	Speaker (s) : Board President
1.5.3. Consider Activity Accounts and Treasurer's Report	Speaker (s) : Board President
1.6. Public Forum	Speaker (s) : Board President
1.6.1. Public forum: This is an opportunity for members of the public to speak to items on the agenda or items of concern to the public. If you are not part of the presentation of an agenda item, you need to speak now. Thank you for your	Speaker (s) : Board President

participation.

2. ACTION ITEMS

Speaker (s): Board
President

**2.1. DISCUSS, REVIEW AND CONSIDER APPROVAL OF
SPECIAL BOND ELECTION RESOLUTION**

Speaker (s): SUPT.
FORD

Action(s):

Motion to approve the Resolution Calling a
Special Election for a School Bond as presented
Passed with a motion by Doug Cast and a second by
Bryce Borchers.

Voting Detail:

Bryce Borchers: Yea
Doug Cast: Yea
Cole Henderson: Yea
Lana Hoffschneider: Yea
Jason Richters: Yea
Derek Tomes: Yea

Voting Summary: Yea: 6, Nay: 0

**2.2. DISCUSS, REVIEW, AND CONSIDER POLICIES 3013-
3022, 4056**

Speaker (s): SUPT.
FORD

Action(s):

Motion to review and approve policies 3013, 3015-
3022 with recommended changes 4056 as presented
Passed with a motion by Lana Hoffschneider and a
second by Derek Tomes.

Voting Detail:

Bryce Borchers: Yea
Doug Cast: Yea
Cole Henderson: Yea
Lana Hoffschneider: Yea
Jason Richters: Yea
Derek Tomes: Yea

Voting Summary: Yea: 6, Nay: 0

**2.3. DISCUSS, REVIEW, AND CONSIDER APPROVAL OF BIDS
FOR FOOTBALL FIELD GOAL POSTS**

Action(s):

Motion to approve the bid for goal posts from
Gale's Welding as presented Passed with a motion
by Derek Tomes and a second by Cole Henderson.

Voting Detail:

Bryce Borchers: Yea
Doug Cast: Yea
Cole Henderson: Yea
Lana Hoffschneider: Yea
Jason Richters: Yea
Derek Tomes: Yea

Voting Summary: Yea: 6, Nay: 0

**2.4. DISCUSS, REVIEW, AND CONSIDER BIDS FOR CEILING
TILE FOR CLASSROOM RENOVATION**

Speaker (s): SUPT.
FORD

Action(s):

Motion to approve ceiling tiles from DSI as
presented Passed with a motion by Cole Henderson

and a second by Lana Hoffschneider.

Voting Detail:

Bryce Borchers: Yea
Doug Cast: Yea
Cole Henderson: Yea
Lana Hoffschneider: Yea
Jason Richters: Yea
Derek Tomes: Yea

Voting Summary: Yea: 6, Nay: 0

2.5. DISCUSS, REVIEW, AND CONSIDER BIDS FOR LIGHTING FOR CLASSROOM RENOVATION **Speaker(s):** SUPT. FORD

Action(s):

Motion to approve bid for lighting from Echo as presented Passed with a motion by Lana Hoffschneider and a second by Derek Tomes.

Voting Detail:

Bryce Borchers: Yea
Doug Cast: Yea
Cole Henderson: Yea
Lana Hoffschneider: Yea
Jason Richters: Yea
Derek Tomes: Yea

Voting Summary: Yea: 6, Nay: 0

2.6. DISCUSS, REVIEW, AND CONSIDER TAKING ACTION TO ACCEPT RESIGNATION(S)

Action(s):

Motion to accept the resignations of Natalie Simmerman and Holly Luettel with regret and best wishes Passed with a motion by Jason Richters and a second by Lana Hoffschneider.

Voting Detail:

Bryce Borchers: Yea
Doug Cast: Yea
Cole Henderson: Yea
Lana Hoffschneider: Yea
Jason Richters: Yea
Derek Tomes: Yea

Voting Summary: Yea: 6, Nay: 0

2.7. DISCUSS, REVIEW, AND CONSIDER TAKING ACTION TO APPROVE NEW HIRE(S)

Action(s):

Motion to approve the new hires of Taylor Eitzmann and Anna Sluka Passed with a motion by Jason Richters and a second by Doug Cast.

Voting Detail:

Bryce Borchers: Yea
Doug Cast: Yea
Cole Henderson: Yea
Lana Hoffschneider: Yea
Jason Richters: Yea

Derek Tomes: Yea

Voting Summary: Yea: 6, Nay: 0

3. **DISCUSSION ITEMS**

Speaker (s): Board
President

3.1. SUPERINTENDENT REPORT

3.2. BOARD RETREAT PLANNING

3.3. DISCUSS GRADUATION REQUIREMENTS FOR 2025-2026

Speaker (s): SUPT.
FORD

3.4. BOARD SELF EVALUATION

3.5. STUDENT RECOGNITION

Speaker (s): SUPT.
FORD

4. **ADJOURN**

Speaker (s): Board
President

Action(s):

Motion to adjourn at 9:41pm Passed with a motion
by Cole Henderson and a second by Doug Cast.

Voting Detail:

Bryce Borchers: Yea

Doug Cast: Yea

Cole Henderson: Yea

Lana Hoffschneider: Yea

Jason Richters: Yea

Derek Tomes: Yea

Voting Summary: Yea: 6, Nay: 0

Board Secretary

<u>Vendor Name</u>	<u>Vendor Description</u>	<u>Amount</u>
Checking	1	
Checking	1 Fund: 01 GENERAL FUND	
ALL COPY PRODUCTS, INC	SUPPLIES	733.74
ALL COPY PRODUCTS	COPIER LEASE	447.89
AMAZON CAPITAL SERVICES	SUPPLIES	608.15
ARNOLD MOTOR SUPPLY	AUTO PARTS	581.69
AXTELL COMMUNITY SCHOOL	ADMIN FEES	6,750.00
B & H PHOTO	A/V EQUIPMENT	89.98
B2 ENVIRONMENTAL, INC	MAINTENANCE TESTING	1,050.00
BARJENBRUCH, CRAIG	REIMBURSEMENT	83.98
BEAVER HARDWARE	FACILITY SUPPLIES	876.80
BEL-CON REFUSE		65.00
BLACK HILLS ENERGY	NATURAL GAS	4,628.99
BOUND TO STAY BOUND	LIBRARY BOOKS	72.34
Capital One	SUPPLIES	193.54
CCS PRESENTATION SYSTEMS	A/V EQUIPMENT	1,719.00
CDW GOVERNMENT, INC	TECHNOLOGY	133.92
CENTENNIAL ACTIVITY FUND	DISTRICT REIMBURSEMENT	1,412.64
CENTENNIAL LUNCH	TRANSFER	308.00
CENTRAL VALLEY AG	FUEL	8,175.81
COLUMN SOFTWARE PBC		95.41
COMFORT INN	TRAVEL	313.34
COMPUTER HARDWARE, INC	COMPUTER HARDWARE	68,080.00
CORNHUSKER CLEANING SYSTEMS, INC	TIRES/PARTS	146.57
DETWEILER, ASHLEY	MILEAGE	404.32
DICKEY, SUSAN	REIMBURSEMENT	135.14
DIETZE MUSIC	SHEET MUSIC/EQUIP	471.22
EASY TIME CLOCK, INC	CLOUD SOFTWARE	103.00
EDGERTON EXPLORIT CENTER		290.00
EDUCATIONAL SERVICE UNIT #6	CONTRACTED SERVICES/SUPPLIES	420.00
FALLER LANDSCAPE, INC	LANDSCAPE SUPPLIES	2,790.00
FEHLHAFFER, KELLY	REIMBURSEMENT	21.80
FICKEL, TERI	REIMBURSEMENT	22.01
FLOWER BOX, THE	OTHER EXP	95.00
GO PHYSICAL THERAPY	PHYSICAL THERAPY	8,620.00
GRAINGER	FACILITY SUPPLIES	72.44
HAYEK, DOUG		300.00
HD Supply Formerly Home Depot Pro		2,466.82
HIRERIGHT LLC	PHYSICAL/TESTING	306.60
HOUCHEN BINDERY LTD	TEXTBOOKS	14.75
HUNDERTMARK CLEANING SYSTEMS, INC	PARTS	78.23
INSPIRA	FEES	100.00
INSTRUMENTALIST AWARDS LLC	SUPPLIES	146.00
J.W. PEPPER & SON, INC	MUSIC	98.75
KOPCHOS SANITATION, INC	SERVICES	782.50
KSB SCHOOL LAW	LEGAL SERVICE	835.50
LOWE'S	SUPPLIES	261.88

<u>Vendor Name</u>	<u>Vendor Description</u>	<u>Amount</u>	
MACKIN EDUCATIONAL RESOURCES	SUPPLIES	247.73	
MATHESON TRI-GAS INC	WELDING SUPPLIES	834.15	
MCCORMICK'S HEATING & AIR CONDITIONING	HVAC MAINTENANCE	2,917.10	
Nebraska Educators Rising		5,445.34	
NORRIS PUBLIC POWER DISTRICT	ELECTRICITY	10,877.48	
NORTH PRINTING & OFFICE SUPPLY	SUPPLIES	13.72	
NOTABLE, INC	WEB/CLOUD	1,685.25	
ONE SOURCE BACKGROUND COMPANY	SERVICES	40.00	
OVERHEAD DOOR CO. OF LINCOLN, INC	SUPPLIES	165.00	
PAC N SAVE - SEWARD	SUPPLIES	226.89	
POSTMASTER	PERMIT FEE	657.00	
POTTER REPAIR	AUTO REPAIR	222.50	
PROVIDENCE WORKING CANINES	SERVICES	495.84	
QUILL CORPORATION	SUPPLIES	24.64	
ROBINSON, CHELSEA		19.62	
SEGRA	WAN FIBER	627.71	
SITE ONE LANDSCAPE SUPPLY	SUPPLIES	454.50	
SOLIZ, DANA E	REIMBURSEMENT	156.14	
STECKLY, SHANNON		61.49	
TRAFERA, LLC	TECHNOLOGY SUPPLIES	32,091.00	
VERIZON CONNECT		379.00	
VERIZON WIRELESS	CELL PHONES	30.04	
VILLAGE OF UTICA	WATER/SEWER	1,342.29	
WINDSTREAM	TELEPHONE	552.80	
ZITO BUSINESS	INTERNET SERVICE	121.69	
	Fund Total:		175,091.67
	Checking Account Total:		175,091.67

<u>Vendor Name</u>		<u>Vendor Description</u>	<u>Amount</u>	
<u>Checking</u>	8			
Checking	8	Fund: 08 SPECIAL BUILDING FUND		
AMERICAN LIFT & SIGN SERVICE			39,649.50	
BULLER DESIGN SCAPES LLC			30,987.00	
INSIGHT PUBLIC SECTOR, INC		TECHNOLOGY	11,939.11	
LOWE'S		SUPPLIES	718.23	
			Fund Total:	83,293.84
			Checking Account Total:	83,293.84

Activity Fund Balance Report - Detail - Exclude Encumbrances

04/2025 - 04/2025

Regular; Beginning Month 04/2025; Processing Month 04/2025; Accounts to Include Accounts with Activity; Fund Number 05

Fund: 05 ACTIVITIES FUND

<u>Chart of Account Number</u>			<u>Chart of Account Description</u>			<u>Entity Name</u>	<u>Expenses</u>	<u>Revenues</u>	<u>Balance Change</u>	<u>Balance</u>
<u>Entry Date</u>	<u>JR</u>	<u>Reference #</u>	<u>Check Acct</u>	<u>Check #</u>	<u>Description</u>					
05 704			Fund Balance			*Previous Balance				(15,730.51)
						*Ending Balance:	0.00	0.00	0.00	(15,730.51)
05 704 0003			ATHLETICS FUND BALANCE			*Previous Balance				(25,663.79)
05 704 0003			ATHLETICS FUND BALANCE							
05 2900 352 000 0 000 0003			ATHLETICS OFFICIALS/JUDGES							
04/14/2025	CD	20250414	5	46338	BA umpires 4/14	Sandoval, Carlos	145.00	0.00		
04/14/2025	CD	20250414	5	46339	BA umpires 4/14	Adkisson, Steve	145.00	0.00		
04/17/2025	CD	20250417	5	46344	BA umpire 417	Sandoval, Carlos	145.00	0.00		
04/17/2025	CD	20250417	5	46345	BA umpire 4/17	Smith, Red	145.00	0.00		
04/29/2025	CD	20250429	5	46355	BA umpire 4/29	Adkisson, Steve	185.00	0.00		
04/29/2025	CD	20250429	5	46356	BA umpire 4/29	Higgins, Timothy	165.00	0.00		
05 2900 610 000 0 000 0003			ATHLETICS SUPPLIES							
04/09/2025	CD	14DQ-DTVP-3FFT	5	46326	spikes for track	AMAZON CAPITAL SERVICES	55.96	0.00		
04/09/2025	CD	1GLY-T934-VVCK	5	46327	earbuds & BA training equipment	AMAZON CAPITAL SERVICES	133.45	0.00		
04/29/2025	CD	698349	5	46357	Discus Net	Litania Sports Group	1,359.00	0.00		
05 2900 810 000 0 000 0003			ATHLETICS DUES AND FEES							
04/07/2025	CD	20250407	5	46320	Track entry fee	HEARTLAND COMMUNITY SCHOOLS	260.00	0.00		
04/07/2025	CD	20250407	5	46310	Track entry fee	Malcolm Public School	180.00	0.00		
04/07/2025	CD	20250407	5	46311	Track entry fee	Wilber-Clatonia Public Schools	170.00	0.00		
04/29/2025	CD	20250429	5	46353	JH Track Entry Fee	Friend Public School	150.00	0.00		
04/29/2025	CD	20250429-0001	5	46354	Golf Entry Fee	Friend Public School	125.00	0.00		
05 2900 890 000 0 000 0003			ATHLETICS MISC EXPENSE							
04/07/2025	CD	20250407	5	46307	Hotels Rooms 2/15 & 3/27	HOLIDAY IN EXPRESS HOTEL & SUITES - KEARNEY, NE	1,519.60	0.00		
04/15/2025	CD	20250415-0001	5	46341	NSWCA	FNBO	100.00	0.00		
04/15/2025	CD	20250415-0001	5	46341	The Headset App	FNBO	39.98	0.00		
05 704 0003			ATHLETICS FUND BALANCE			*Current Activity				(5,022.99)
						*Ending Balance:	5,022.99	0.00	0.00	(30,686.78)
05 704 0050			CONCESSIONS FUND BALANCE			*Previous Balance				30,695.58
05 704 0050			CONCESSIONS FUND BALANCE							
05 1790 0050			CONCESSIONS							
04/21/2025	CR	AUTO			Conc 4/17 CC Charges	Square Inc.	0.00	55.54		
04/23/2025	CR	18196			JH Track Conc 4/17	Klanecky, Nikki	0.00	927.75		
04/23/2025	CR	18197			Track Con 4/22	Klanecky, Nikki	0.00	1,173.55		
04/23/2025	CR	18198			Conc 4/22 tips (post prom)	Klanecky, Nikki	0.00	3.75		
04/24/2025	CR	AUTO			Conc 4/22 CC Charges	Square Inc.	0.00	90.12		
04/28/2025	CR	18199			Elem. Fun Night Conc	Klanecky, Nikki	0.00	538.50		
04/28/2025	CR	18200			Elem Fun Night Tips	Klanecky, Nikki	0.00	4.00		
04/28/2025	CR	AUTO			Conc 4/25 CC Charges	Square Inc.	0.00	910.20		
04/30/2025	CR	18201			Track conc 4/28	Klanecky, Nikki	0.00	581.00		

Activity Fund Balance Report - Detail - Exclude Encumbrances

04/2025 - 04/2025

Regular; Beginning Month 04/2025; Processing Month 04/2025; Accounts to Include Accounts with Activity; Fund Number 05

Fund: 05 ACTIVITIES FUND

<u>Chart of Account Number</u>			<u>Chart of Account Description</u>			<u>Entity Name</u>	<u>Expenses</u>	<u>Revenues</u>	<u>Balance Change</u>	<u>Balance</u>
<u>Entry Date</u>	<u>JR</u>	<u>Reference #</u>	<u>Check Acct</u>	<u>Check #</u>	<u>Description</u>					
04/30/2025	CR	18202			JH Track Conc 4/29	Klanecky, Nikki	0.00	2,509.75		
04/30/2025	CR	18203			Post Prom tip money conc 4/29	Klanecky, Nikki	0.00	11.00		
04/30/2025	CR	AUTO			Conc 4/28 CC Charges	Square Inc.	0.00	128.54		
05 2900 610 000 0 000 0050					CONCESSIONS SUPPLIES					
04/15/2025	CD	20250415	5	46342	supplies	Sam's Club/Synchrony Bank	71.16	0.00		
05 704 0050					CONCESSIONS FUND BALANCE	*Current Activity				6,862.54
						*Ending Balance:	71.16	6,933.70	0.00	37,558.12
05 704 0052					BRONCO STORE FUND BALANCE	*Previous Balance				1,697.04
05 704 0052					BRONCO STORE FUND BALANCE					
05 2900 610 000 0 000 0052					BRONCO STORE SUPPLIES					
04/09/2025	CD	20250409	5	46324	pizza for ACT testing	BRONCO SPUR	204.00	0.00		
05 2900 890 000 0 000 0052					BRONCO STORE MISC EXPENSE					
04/09/2025	CD	20250409	5	46325	Breakfast for ACT test day	CENTENNIAL MARKET	33.32	0.00		
05 704 0052					BRONCO STORE FUND BALANCE	*Current Activity				(237.32)
						*Ending Balance:	237.32	0.00	0.00	1,459.72
05 704 0053					MARKET 67 FUND BALANCE	*Previous Balance				1,155.74
						*Ending Balance:	0.00	0.00	0.00	1,155.74
05 704 0054					BRONCO CLOSET FUND BALANCE	*Previous Balance				834.41
						*Ending Balance:	0.00	0.00	0.00	834.41
05 704 0055					BRONCO COFFEE & CREATIONS FUND BALANCE	*Previous Balance				45.38
						*Ending Balance:	0.00	0.00	0.00	45.38
05 704 0056					SUMMER CAMPS FUND BALANCE	*Previous Balance				1,854.92
						*Ending Balance:	0.00	0.00	0.00	1,854.92
05 704 0057					PBIS FUND BALANCE	*Previous Balance				(202.87)
						*Ending Balance:	0.00	0.00	0.00	(202.87)
05 704 0103					DISTRICT EVENTS FUND BALANCE	*Previous Balance				15,361.21
05 704 0103					DISTRICT EVENTS FUND BALANCE					
05 2900 610 000 0 000 0103					DISTRICT EVENTS SUPPLIES					
04/09/2025	CD	20250409	5	46334	Senior Life Skills Day	PAC N SAVE - SEWARD	33.57	0.00		
04/09/2025	CD	20250409-0001	5	46335	Senior Life Skills Day	CENTENNIAL MARKET	148.73	0.00		
05 2900 890 000 0 000 0103					DISTRICT EVENTS MISC EXPENSE					
04/09/2025	CD	20250409	5	46325	brownies for honor roll	CENTENNIAL MARKET	271.81	0.00		
04/15/2025	CD	20250415	5	46342	fees	Sam's Club/Synchrony Bank	52.75	0.00		
05 704 0103					DISTRICT EVENTS FUND BALANCE	*Current Activity				(506.86)
						*Ending Balance:	506.86	0.00	0.00	14,854.35

Activity Fund Balance Report - Detail - Exclude Encumbrances

04/2025 - 04/2025

Regular; Beginning Month 04/2025; Processing Month 04/2025; Accounts to Include Accounts with Activity; Fund Number 05

Fund: 05 ACTIVITIES FUND

Chart of Account Number		Chart of Account Description			Entity Name	Expenses	Revenues	Balance Change	Balance
Entry Date	JR	Reference #	Check Acct	Check #	Description				
05 704 0104					BOYS BASKETBALL FUND BALANCE				869.85
					*Previous Balance				869.85
					*Ending Balance:	0.00	0.00	0.00	869.85
05 704 0105					CROSS COUNTRY FUND BALANCE				290.90
					*Previous Balance				290.90
					*Ending Balance:	0.00	0.00	0.00	290.90
05 704 0106					FOOTBALL FUND BALANCE				1,852.77
					*Previous Balance				1,852.77
					*Ending Balance:	0.00	0.00	0.00	1,852.77
05 704 0107					GIRLS BASKETBALL FUND BALANCE				1,335.50
					*Previous Balance				1,335.50
					*Ending Balance:	0.00	0.00	0.00	1,335.50
05 704 0108					GOLF FUND BALANCE				(63.69)
05 704 0108					GOLF FUND BALANCE				
05 2900 610 000 0 000 0108					GOLF SUPPLIES				
04/09/2025	CD	929172036	5	46321	Golf gear	BSN SPORTS LLC	1,189.24	0.00	
05 704 0108					GOLF FUND BALANCE				(1,189.24)
					*Current Activity				(1,189.24)
					*Ending Balance:	1,189.24	0.00	0.00	(1,252.93)
05 704 0109					SOFTBALL FUND BALANCE				1,788.84
					*Previous Balance				1,788.84
					*Ending Balance:	0.00	0.00	0.00	1,788.84
05 704 0115					TRACK FUND BALANCE				305.46
					*Previous Balance				305.46
					*Ending Balance:	0.00	0.00	0.00	305.46
05 704 0116					VOLLEYBALL FUND BALANCE				5,664.80
05 704 0116					VOLLEYBALL FUND BALANCE				
05 2900 352 000 0 000 0116					VOLLEYBALL OFFICIALS/JUDGES				
04/22/2025	CD	20250422	5	46346	Club VB coaches	Keck, Ashley	500.00	0.00	
04/22/2025	CD	20250422	5	46347	Club VB coaches	Kirkegaard, Adeline	500.00	0.00	
04/22/2025	CD	20250422	5	46348	Club VB coaches	Evert, Clara	450.00	0.00	
04/22/2025	CD	20250422	5	46349	Club VB coaches	Faalii, Shandy	450.00	0.00	
05 2900 810 000 0 000 0116					VOLLEYBALL DUES AND FEES				
04/28/2025	CD	20250428	5	46351	VB Coaches Clinic	Boldt Volleyball, LLC	225.00	0.00	
05 704 0116					VOLLEYBALL FUND BALANCE				(2,125.00)
					*Current Activity				(2,125.00)
					*Ending Balance:	2,125.00	0.00	0.00	3,539.80
05 704 0117					WRESTLING FUND BALANCE				2,497.64
					*Previous Balance				2,497.64
					*Ending Balance:	0.00	0.00	0.00	2,497.64
05 704 0118					BASEBALL FUND BALANCE				658.78
					*Previous Balance				658.78
					*Ending Balance:	0.00	0.00	0.00	658.78
05 704 0119					GIRLS WRESTLING FUND BALANCE				1,604.92
					*Previous Balance				1,604.92

Activity Fund Balance Report - Detail - Exclude Encumbrances

04/2025 - 04/2025

Regular; Beginning Month 04/2025; Processing Month 04/2025; Accounts to Include Accounts with Activity; Fund Number 05

Fund: 05 ACTIVITIES FUND

<u>Chart of Account Number</u>		<u>Chart of Account Description</u>			<u>Entity Name</u>	<u>Expenses</u>	<u>Revenues</u>	<u>Balance Change</u>	<u>Balance</u>
<u>Entry Date</u>	<u>JR</u>	<u>Reference #</u>	<u>Check Acct</u>	<u>Check #</u>	<u>Description</u>				
05 704 0119					GIRLS WRESTLING FUND BALANCE				
05 2900 610 000 0 000 0119					GIRLS WRESTLING SUPPLIES				
04/07/2025	CD	20250407-0001	5	46309	shirts	Kobie's Kreations	36.00	0.00	
05 704 0119					GIRLS WRESTLING FUND BALANCE				
					*Current Activity				(36.00)
					*Ending Balance:	36.00	0.00	0.00	1,568.92
05 704 0204					JH BOYS BASKETBALL FUND BALANCE				
					*Previous Balance				138.35
05 704 0204					JH BOYS BASKETBALL FUND BALANCE				
05 2900 610 000 0 000 0204					JH BOYS BASKETBALL SUPPLIES				
04/07/2025	CD	20250407	5	46308	JH BBB Shirts	Kobie's Kreations	140.00	0.00	
05 704 0204					JH BOYS BASKETBALL FUND BALANCE				
					*Current Activity				(140.00)
					*Ending Balance:	140.00	0.00	0.00	(1.65)
05 704 0207					JH GIRLS BASKETBALL FUND BALANCE				
					*Previous Balance				1,088.82
					*Ending Balance:	0.00	0.00	0.00	1,088.82
05 704 0215					JH TRACK FUND BALANCE				
					*Previous Balance				271.10
					*Ending Balance:	0.00	0.00	0.00	271.10
05 704 0216					JH VOLLEYBALL FUND BALANCE				
					*Previous Balance				60.11
					*Ending Balance:	0.00	0.00	0.00	60.11
05 704 0301					ART FUND BALANCE				
					*Previous Balance				19.59
					*Ending Balance:	0.00	0.00	0.00	19.59
05 704 0303					DANCE/CHEER FUND BALANCE				
					*Previous Balance				(3,854.54)
05 704 0303					DANCE/CHEER FUND BALANCE				
05 2900 890 000 0 000 0303					DANCE/CHEER MISC EXPENSE				
04/07/2025	CD	20250407	5	46313	Cheer/Dance Team Fundraiser	Nothing Bundt Cakes	4,226.80	0.00	
05 704 0303					DANCE/CHEER FUND BALANCE				
					*Current Activity				(4,226.80)
					*Ending Balance:	4,226.80	0.00	0.00	(8,081.34)
05 704 0304					E-SPORTS FUND BALANCE				
					*Previous Balance				(100.19)
					*Ending Balance:	0.00	0.00	0.00	(100.19)
05 704 0305					FBLA FUND BALANCE				
					*Previous Balance				321.52
05 704 0305					FBLA FUND BALANCE				
05 2900 610 000 0 000 0305					FBLA SUPPLIES				
04/28/2025	CD	20250428	5	46350	FBLA Nat'l Convention Pins	Arlington Public Schools	20.00	0.00	
05 704 0305					FBLA FUND BALANCE				
					*Current Activity				(20.00)
					*Ending Balance:	20.00	0.00	0.00	301.52
05 704 0306					FCCLA FUND BALANCE				
					*Previous Balance				2,030.74

Activity Fund Balance Report - Detail - Exclude Encumbrances

04/2025 - 04/2025

Regular; Beginning Month 04/2025; Processing Month 04/2025; Accounts to Include Accounts with Activity; Fund Number 05

Fund: 05 ACTIVITIES FUND

<u>Chart of Account Number</u>		<u>Chart of Account Description</u>		<u>Entity Name</u>	<u>Expenses</u>	<u>Revenues</u>	<u>Balance Change</u>	<u>Balance</u>
<u>Entry Date</u>	<u>JR</u>	<u>Reference #</u>	<u>Check Acct</u>	<u>Check #</u>	<u>Description</u>			
05 704 0306					FCCLA FUND BALANCE			
05 2900 610 000 0 000 0306					FCCLA SUPPLIES			
04/07/2025	CD	20250407	5	46317	kblr grhm orig	CENTENNIAL MARKET	31.74	0.00
04/15/2025	CD	20250415-0001	5	46341	uniforms today FCCLA	FNBO	355.20	0.00
05 704 0306					FCCLA FUND BALANCE	*Current Activity		(386.94)
						*Ending Balance:	386.94	0.00
							0.00	1,643.80
05 704 0307					FFA FUND BALANCE	*Previous Balance		43,469.38
05 704 0307					FFA FUND BALANCE			
05 2900 610 000 0 000 0307					FFA SUPPLIES			
04/07/2025	CD	1498 & 1518	5	46314	FFA Shirts	Ink Images Custom Apparel	1,019.76	0.00
04/07/2025	CD	20250407	5	46316	oak for plaques	Capital One Trade Credit	65.16	0.00
04/09/2025	CD	20250409	5	46329	supplies for FFA - Casey's & Walmart	Krohe, Cissanie	37.12	0.00
05 2900 810 000 0 000 0307					FFA DUES AND FEES			
04/09/2025	CD	State Conv 3036	5	46323	Registration State Convention	Nebraska FFA Association	455.00	0.00
05 2900 890 000 0 000 0307					FFA MISC EXPENSE			
04/09/2025	CD	20250409	5	46330	Food Livestock judging	Mexcellent Grill, LLC, The	141.36	0.00
04/09/2025	CD	20250409	5	46331	Food @ Livestock Contest 3/26	Leadership Center, The	100.00	0.00
04/09/2025	CD	20250409	5	46324	pizzas	BRONCO SPUR	34.00	0.00
04/09/2025	CD	20250409	5	46322	Food for FFA - Runza	LUETTEL, HOLLY ANNE	36.52	0.00
05 704 0307					FFA FUND BALANCE	*Current Activity		(1,888.92)
						*Ending Balance:	1,888.92	0.00
							0.00	41,580.46
05 704 0308					MUSICAL FUND BALANCE	*Previous Balance		7,447.49
05 704 0308					MUSICAL FUND BALANCE			
05 1710 0308					MUSICAL ADMISSIONS			
04/15/2025	CR	18193			Musical Day 1	Luebbe, Jessica	0.00	468.00
04/15/2025	CR	18194			Musical Day 2	Luebbe, Jessica	0.00	345.00
05 1790 0308					MUSICAL			
04/15/2025	CR	18195			Musical Pre-Sales	Luebbe, Jessica	0.00	2,057.00
05 2900 610 000 0 000 0308					MUSICAL SUPPLIES			
04/07/2025	CD	20250407	5	46315	musical supplies	FOWLER, JARRETT K	617.94	0.00
04/09/2025	CD	331911	5	46336	Musical Supplies	BEAVER HARDWARE	72.94	0.00
04/15/2025	CD	20250415	5	46340	musical set supplies	FNBO	276.50	0.00
05 2900 890 000 0 000 0308					MUSICAL MISC EXPENSE			
04/09/2025	CD	20250409	5	46324	pizza	BRONCO SPUR	158.00	0.00
05 704 0308					MUSICAL FUND BALANCE	*Current Activity		1,744.62
						*Ending Balance:	1,125.38	2,870.00
							0.00	9,192.11
05 704 0309					NHS FUND BALANCE	*Previous Balance		176.06
						*Ending Balance:	0.00	0.00
							0.00	176.06

Activity Fund Balance Report - Detail - Exclude Encumbrances

04/2025 - 04/2025

Regular; Beginning Month 04/2025; Processing Month 04/2025; Accounts to Include Accounts with Activity; Fund Number 05

Fund: 05 ACTIVITIES FUND

Chart of Account Number		Chart of Account Description			Entity Name	Expenses	Revenues	Balance Change	Balance
Entry Date	JR	Reference #	Check Acct	Check #	Description				
05 704 0311					ONE ACT FUND BALANCE				376.80
					*Previous Balance				376.80
					*Ending Balance:	0.00	0.00	0.00	376.80
05 704 0312					QUIZ BOWL FUND BALANCE				749.24
					*Previous Balance				749.24
					*Ending Balance:	0.00	0.00	0.00	749.24
05 704 0313					SHOW CHOIR FUND BALANCE				(6,266.33)
					*Previous Balance				(6,266.33)
					*Ending Balance:	0.00	0.00	0.00	(6,266.33)
05 704 0314					SPEECH FUND BALANCE				240.39
05 704 0314					SPEECH FUND BALANCE				
05 2900 890 000 0 000 0314					SPEECH MISC EXPENSE				
04/09/2025	CD	20250409	5	46328	Speech judge	Turnbull, Stacie	180.00	0.00	
05 704 0314					SPEECH FUND BALANCE				(180.00)
					*Current Activity				(180.00)
					*Ending Balance:	180.00	0.00	0.00	60.39
05 704 0315					STUDENT COUNCIL FUND BALANCE				2,818.02
					*Previous Balance				2,818.02
					*Ending Balance:	0.00	0.00	0.00	2,818.02
05 704 0316					UNIFIED ACTIVITIES FUND BALANCE				116.90
					*Previous Balance				116.90
					*Ending Balance:	0.00	0.00	0.00	116.90
05 704 0317					ISTRUMENTAL MUSIC				223.98
05 704 0317					ISTRUMENTAL MUSIC				
05 2900 610 000 0 000 0317					ISTRUMENTAL MUSIC SUPPLIES				
04/15/2025	CD	20250415-0001	5	46341	PAYPAL *TWINKL LTD	FNBO	9.00	0.00	
04/16/2025	CD	20250416	5	46343	Band supplies	DIETZE MUSIC	45.00	0.00	
05 704 0317					ISTRUMENTAL MUSIC				(54.00)
					*Current Activity				(54.00)
					*Ending Balance:	54.00	0.00	0.00	169.98
05 704 0318					VOCAL MUSIC FUND BALANCE				(156.00)
					*Previous Balance				(156.00)
					*Ending Balance:	0.00	0.00	0.00	(156.00)
05 704 0319					MIDDLE SCHOOL QUIZ BOWL FUND BALANCE				1,105.14
					*Previous Balance				1,105.14
					*Ending Balance:	0.00	0.00	0.00	1,105.14
05 704 0320					FCA FUND BALANCE				274.62
					*Previous Balance				274.62
					*Ending Balance:	0.00	0.00	0.00	274.62
05 704 0321					EdRISING FUND BALANCE				3,155.55
05 704 0321					EdRISING FUND BALANCE				
05 2900 890 000 0 000 0321					EdRISING MISC EXPENSE				
04/15/2025	CD	20250415-0001	5	46341	Hotel rooms for EdRising SLC	FNBO	449.76	0.00	

Activity Fund Balance Report - Detail - Exclude Encumbrances

04/2025 - 04/2025

Regular; Beginning Month 04/2025; Processing Month 04/2025; Accounts to Include Accounts with Activity; Fund Number 05

Fund: 05 ACTIVITIES FUND

Chart of Account Number		Chart of Account Description			Entity Name	Expenses	Revenues	Balance Change	Balance
Entry Date	JR	Reference #	Check Acct	Check #	Description				
05 704 0321		EdRISING FUND BALANCE			*Current Activity				(449.76)
					*Ending Balance:	449.76	0.00	0.00	2,705.79
05 704 0406		CLASS 2025 FUND BALANCE			*Previous Balance				3,121.56
05 704 0406		CLASS 2025 FUND BALANCE							
05 2900 610 000 0 000 0406		CLASS 2025 SUPPLIES							
04/09/2025	CD	20250409	5	46333	Prom supplies	AMAZON CAPITAL SERVICES	514.94	0.00	
04/09/2025	CD	1596	5	46332	Graduation caps/gowns/tassel/stoles	Graves, Troy	1,829.58	0.00	
05 704 0406		CLASS 2025 FUND BALANCE			*Current Activity				(2,344.52)
					*Ending Balance:	2,344.52	0.00	0.00	777.04
05 704 0407		CLASS 2026 FUND BALANCE			*Previous Balance				4,815.08
05 704 0407		CLASS 2026 FUND BALANCE							
05 2900 890 000 0 000 0407		CLASS 2026 MISC EXPENSE							
04/07/2025	CD	20250407	5	46305	2025 Prom DJ	Ostendorf, Riley	300.00	0.00	
04/07/2025	CD	20250407	5	46306	2025 Prom Pictures	Hoffschneider, Cora	300.00	0.00	
05 704 0407		CLASS 2026 FUND BALANCE			*Current Activity				(600.00)
					*Ending Balance:	600.00	0.00	0.00	4,215.08
05 704 0408		CLASS 2027 FUND BALANCE			*Previous Balance				1,446.06
					*Ending Balance:	0.00	0.00	0.00	1,446.06
05 704 0409		CLASS 2028 FUND BALANCE			*Previous Balance				2,602.09
					*Ending Balance:	0.00	0.00	0.00	2,602.09
05 704 0700		BOOSTER CLUB FUND BALANCE			*Previous Balance				(467.48)
					*Ending Balance:	0.00	0.00	0.00	(467.48)
05 704 0702		CHROMEBOOK ASSURANCE FUND BALANCE			*Previous Balance				6,785.64
05 704 0702		CHROMEBOOK ASSURANCE FUND BALANCE							
05 2900 610 000 0 000 0702		CHROMEBOOK ASSURANCE SUPPLIES							
04/09/2025	CD	1MWD-H7PX-4NM3	5	46337	power adapter	AMAZON CAPITAL SERVICES	208.90	0.00	
05 2900 890 000 0 000 0702		CHROMEBOOK ASSURANCE MISC EXPENSE							
04/07/2025	CD	1001271507	5	46312	CB Screen replacement	TRAFERA, LLC	75.00	0.00	
04/29/2025	CD	1001301380	5	46352	Chromebook repairs	TRAFERA, LLC	81.25	0.00	
05 704 0702		CHROMEBOOK ASSURANCE FUND BALANCE			*Current Activity				(365.15)
					*Ending Balance:	365.15	0.00	0.00	6,420.49
05 704 0705		LIBRARY FUND BALANCE			*Previous Balance				31.47
					*Ending Balance:	0.00	0.00	0.00	31.47

Activity Fund Balance Report - Detail - Exclude Encumbrances

04/2025 - 04/2025

Regular; Beginning Month 04/2025; Processing Month 04/2025; Accounts to Include Accounts with Activity; Fund Number 05

Fund: 05 ACTIVITIES FUND

<u>Chart of Account Number</u>	<u>Chart of Account Description</u>	<u>Entity Name</u>	<u>Expenses</u>	<u>Revenues</u>	<u>Balance Change</u>	<u>Balance</u>
05 704 0706	SCIENCE FUND BALANCE	*Previous Balance				890.81
		*Ending Balance:	0.00	0.00	0.00	890.81
05 704 0707	WEIGHT ROOM FUND BALANCE	*Previous Balance				(339.93)
05 704 0707	WEIGHT ROOM FUND BALANCE					
05 2900 890 000 0 000 0707	WEIGHT ROOM MISC EXPENSE					
04/07/2025 CD 21-081782	5 46318 weight room service	JOHNSON FITNESS & WELLNESS	380.30	0.00		
05 704 0707	WEIGHT ROOM FUND BALANCE	*Current Activity				(380.30)
		*Ending Balance:	380.30	0.00	0.00	(720.23)
05 704 0708	YEARBOOK FUND BALANCE	*Previous Balance				6,529.80
		*Ending Balance:	0.00	0.00	0.00	6,529.80
05 704 0709	SHOP/TECH FUND BALANCE	*Previous Balance				2,689.10
		*Ending Balance:	0.00	0.00	0.00	2,689.10
05 704 0710	CHESS CLUB FUND BALANCE	*Previous Balance				402.02
		*Ending Balance:	0.00	0.00	0.00	402.02
05 704 0800	CENTENNIAL CHOICE FUND BALANCE	*Previous Balance				15,907.38
		*Ending Balance:	0.00	0.00	0.00	15,907.38
05 704 0801	DISTRICT REIMBURSEMENT FUND BALANCE	*Previous Balance				(409.38)
05 704 0801	DISTRICT REIMBURSEMENT FUND BALANCE					
05 2900 610 000 0 000 0801	DISTRICT REIMBURSEMENT SUPPLIES					
04/09/2025 CD 1596	5 46332 Graduation diplomas & diploma covers	Graves, Troy	751.17	0.00		
05 704 0801	DISTRICT REIMBURSEMENT FUND BALANCE	*Current Activity				(751.17)
		*Ending Balance:	751.17	0.00	0.00	(1,160.55)
05 704 0900	GENERAL FUND BALANCE	*Previous Balance				3,058.14
05 704 0900	GENERAL FUND BALANCE					
05 2900 890 000 0 000 0900	GENERAL MISC EXPENSE					
04/07/2025 CD 1642	5 46319 Freshmen Field Trip Lunch at UNL	BIG RED BUSINESS CENTER	237.50	0.00		
04/15/2025 CD 20250415	5 46340 Walmart.com charges	FNBO	128.75	0.00		
05 704 0900	GENERAL FUND BALANCE	*Current Activity				(366.25)
		*Ending Balance:	366.25	0.00	0.00	2,691.89
		Fund Total: 05	22,467.76	9,803.70	0.00	114,957.92

Register Report - Last month
4/1/2025 through 4/30/2025

Date	Account	Num	Description	Memo	Category	Tag	Tax ...	Clr	Amount
BALANCE 3/31/2025									
4/3/2025	Elementary	7095	Centennial Lunch Fund	food & supplies [Fundraiser]		Preschool Advi...			R-45.00
4/3/2025	Elementary	7096	Centennial Lunch Fund	food & supplies [Fundraiser]		family night			R-60.00
4/3/2025	Elementary	7097	Centennial Activity Fund- ...	Candy from C... [Fundraiser]		PBIS Rewards			-25.00
4/3/2025	Elementary	7098	Food Bank Of Lincoln	2nd Semester... [BACKPACK]		Backpack Prog...			R-4,131.00
4/4/2025	Elementary	884589	5th Grade Parents	Parent admiss... [General]		5th grade field t...			R30.00
4/4/2025	Elementary	7099	Hastings Imax Museum	5th grade field... [General]		field trip			R-153.00
4/9/2025	Elementary	7100	Nebraska Bounce	Bounce house [Fundraiser]		prek-family fun ...			R-200.00
4/14/2025	Elementary	884590	NSNA District One	Donation from... [BACKPACK]		donation			R30.13
4/1/2025 - 4/30/2025									
BALANCE 4/30/2025									
TOTAL INFLOWS									60.13
TOTAL OUTFLOWS									-4,614.00
NET TOTAL									-4,553.87

Account Balances - As of 5/2/2025

Account	5/2/2025 Balance
Bank Accounts	
Elementary	30,522.41
Reading Classic	0.00
Savings	3,016.21
TOTAL Bank Accounts	33,538.62
Liability Accounts	
BACKPACK	-5,491.36
Books	-203.84
Boxtops	-1,721.84
Camp Invention	-8,600.00
Fundraiser	-13,233.08
General	-2,080.86
Girls on the Run	-363.94
Pictures	0.00
Polk Grant	0.00
Supplies Grant	-520.39
TOTAL Liability Accounts	-32,215.31
OVERALL TOTAL	1,323.31

Activity Fund Balance Report - Summary - Exclude Encumbrances

04/2025 - 04/2025

Regular; Beginning Month 04/2025; Processing Month 04/2025; Accounts to Include Accounts with Activity; Fund Number 05

Fund: 05 ACTIVITIES FUND

<u>Chart of Account Number</u>	<u>Chart of Account Description</u>	<u>Beginning Balance</u>	<u>Expenses</u>	<u>Revenues</u>	<u>Balance Change</u>	<u>Balance</u>
05 704	Fund Balance	(15,730.51)	0.00	0.00	0.00	(15,730.51)
05 704 0003	ATHLETICS FUND BALANCE	(25,663.79)	5,022.99	0.00	0.00	(30,686.78)
05 704 0050	CONCESSIONS FUND BALANCE	30,695.58	71.16	6,933.70	0.00	37,558.12
05 704 0052	BRONCO STORE FUND BALANCE	1,697.04	237.32	0.00	0.00	1,459.72
05 704 0053	MARKET 67 FUND BALANCE	1,155.74	0.00	0.00	0.00	1,155.74
05 704 0054	BRONCO CLOSET FUND BALANCE	834.41	0.00	0.00	0.00	834.41
05 704 0055	BRONCO COFFEE & CREATIONS FUND BALANCE	45.38	0.00	0.00	0.00	45.38
05 704 0056	SUMMER CAMPS FUND BALANCE	1,854.92	0.00	0.00	0.00	1,854.92
05 704 0057	PBIS FUND BALANCE	(202.87)	0.00	0.00	0.00	(202.87)
05 704 0103	DISTRICT EVENTS FUND BALANCE	15,361.21	506.86	0.00	0.00	14,854.35
05 704 0104	BOYS BASKETBALL FUND BALANCE	869.85	0.00	0.00	0.00	869.85
05 704 0105	CROSS COUNTRY FUND BALANCE	290.90	0.00	0.00	0.00	290.90
05 704 0106	FOOTBALL FUND BALANCE	1,852.77	0.00	0.00	0.00	1,852.77
05 704 0107	GIRLS BASKETBALL FUND BALANCE	1,335.50	0.00	0.00	0.00	1,335.50
05 704 0108	GOLF FUND BALANCE	(63.69)	1,189.24	0.00	0.00	(1,252.93)
05 704 0109	SOFTBALL FUND BALANCE	1,788.84	0.00	0.00	0.00	1,788.84
05 704 0115	TRACK FUND BALANCE	305.46	0.00	0.00	0.00	305.46
05 704 0116	VOLLEYBALL FUND BALANCE	5,664.80	2,125.00	0.00	0.00	3,539.80
05 704 0117	WRESTLING FUND BALANCE	2,497.64	0.00	0.00	0.00	2,497.64
05 704 0118	BASEBALL FUND BALANCE	658.78	0.00	0.00	0.00	658.78
05 704 0119	GIRLS WRESTLING FUND BALANCE	1,604.92	36.00	0.00	0.00	1,568.92
05 704 0204	JH BOYS BASKETBALL FUND BALANCE	138.35	140.00	0.00	0.00	(1.65)
05 704 0207	JH GIRLS BASKETBALL FUND BALANCE	1,088.82	0.00	0.00	0.00	1,088.82
05 704 0215	JH TRACK FUND BALANCE	271.10	0.00	0.00	0.00	271.10
05 704 0216	JH VOLLEYBALL FUND BALANCE	60.11	0.00	0.00	0.00	60.11
05 704 0301	ART FUND BALANCE	19.59	0.00	0.00	0.00	19.59
05 704 0303	DANCE/CHEER FUND BALANCE	(3,854.54)	4,226.80	0.00	0.00	(8,081.34)
05 704 0304	E-SPORTS FUND BALANCE	(100.19)	0.00	0.00	0.00	(100.19)
05 704 0305	FBLA FUND BALANCE	321.52	20.00	0.00	0.00	301.52
05 704 0306	FCCLA FUND BALANCE	2,030.74	386.94	0.00	0.00	1,643.80
05 704 0307	FFA FUND BALANCE	43,469.38	1,888.92	0.00	0.00	41,580.46
05 704 0308	MUSICAL FUND BALANCE	7,447.49	1,125.38	2,870.00	0.00	9,192.11
05 704 0309	NHS FUND BALANCE	176.06	0.00	0.00	0.00	176.06
05 704 0311	ONE ACT FUND BALANCE	376.80	0.00	0.00	0.00	376.80
05 704 0312	QUIZ BOWL FUND BALANCE	749.24	0.00	0.00	0.00	749.24
05 704 0313	SHOW CHOIR FUND BALANCE	(6,266.33)	0.00	0.00	0.00	(6,266.33)

Activity Fund Balance Report - Summary - Exclude Encumbrances

04/2025 - 04/2025

Regular; Beginning Month 04/2025; Processing Month 04/2025; Accounts to Include Accounts with Activity; Fund Number 05

Fund: 05 ACTIVITIES FUND

<u>Chart of Account Number</u>	<u>Chart of Account Description</u>	<u>Beginning Balance</u>	<u>Expenses</u>	<u>Revenues</u>	<u>Balance Change</u>	<u>Balance</u>
05 704 0314	SPEECH FUND BALANCE	240.39	180.00	0.00	0.00	60.39
05 704 0315	STUDENT COUNCIL FUND BALANCE	2,818.02	0.00	0.00	0.00	2,818.02
05 704 0316	UNIFIED ACTIVITIES FUND BALANCE	116.90	0.00	0.00	0.00	116.90
05 704 0317	ISTRUMENTAL MUSIC	223.98	54.00	0.00	0.00	169.98
05 704 0318	VOCAL MUSIC FUND BALANCE	(156.00)	0.00	0.00	0.00	(156.00)
05 704 0319	MIDDLE SCHOOL QUIZ BOWL FUND BALANCE	1,105.14	0.00	0.00	0.00	1,105.14
05 704 0320	FCA FUND BALANCE	274.62	0.00	0.00	0.00	274.62
05 704 0321	EdRISING FUND BALANCE	3,155.55	449.76	0.00	0.00	2,705.79
05 704 0406	CLASS 2025 FUND BALANCE	3,121.56	2,344.52	0.00	0.00	777.04
05 704 0407	CLASS 2026 FUND BALANCE	4,815.08	600.00	0.00	0.00	4,215.08
05 704 0408	CLASS 2027 FUND BALANCE	1,446.06	0.00	0.00	0.00	1,446.06
05 704 0409	CLASS 2028 FUND BALANCE	2,602.09	0.00	0.00	0.00	2,602.09
05 704 0700	BOOSTER CLUB FUND BALANCE	(467.48)	0.00	0.00	0.00	(467.48)
05 704 0702	CHROMEBOOK ASSURANCE FUND BALANCE	6,785.64	365.15	0.00	0.00	6,420.49
05 704 0705	LIBRARY FUND BALANCE	31.47	0.00	0.00	0.00	31.47
05 704 0706	SCIENCE FUND BALANCE	890.81	0.00	0.00	0.00	890.81
05 704 0707	WEIGHT ROOM FUND BALANCE	(339.93)	380.30	0.00	0.00	(720.23)
05 704 0708	YEARBOOK FUND BALANCE	6,529.80	0.00	0.00	0.00	6,529.80
05 704 0709	SHOP/TECH FUND BALANCE	2,689.10	0.00	0.00	0.00	2,689.10
05 704 0710	CHESS CLUB FUND BALANCE	402.02	0.00	0.00	0.00	402.02
05 704 0800	CENTENNIAL CHOICE FUND BALANCE	15,907.38	0.00	0.00	0.00	15,907.38
05 704 0801	DISTRICT REIMBURSEMENT FUND BALANCE	(409.38)	751.17	0.00	0.00	(1,160.55)
05 704 0900	GENERAL FUND BALANCE	3,058.14	366.25	0.00	0.00	2,691.89
Fund Total: 05		<u>127,621.98</u>	<u>22,467.76</u>	<u>9,803.70</u>	<u>0.00</u>	<u>114,957.92</u>

May 2025 Board Meeting		CENTENNIAL PUBLIC SCHOOL TREASURER'S REPORT				
April 2025 Bank Statements						
FUND	BANK	TYPE OF INVESTMENT		AMOUNT	INT. REC.	
Lunch Fund	First Bank of Utica	Checking		<u>\$11,189.47</u>		
			Total	\$11,189.47		
Depreciation Fund	Farmers & Merchants	MMA		<u>\$43,138.78</u>	\$14.66	
			Total	\$43,138.78		
Unemployment Ins.	Cornerstone Bank	CD		\$61,050.94	\$0.00	(No activity in April)
	Cornerstone Bank	MMA		<u>\$7,364.92</u>	<u>\$5.36</u>	
			Total	\$68,415.86	\$5.36	
Building Fund	First Bank of Utica	Building Fund		\$582,771.93	\$1,242.35	
		Bond Fund		<u>\$497,711.99</u>	<u>\$1,003.76</u>	
			Total	\$1,080,483.92	\$2,246.11	
General Account	York State, Gresham	CD		\$200,501.32	\$2,121.46	
	First Bank of Utica	PayFlex Acct		\$18,412.98		
			Total	\$218,914.30	\$2,121.46	
	First Bank of Utica	Checking		<u>\$2,249,417.65</u>	\$2,657.65	
		General Fund Total	\$2,473,111.06			
		Total Invested All Accounts Combined		<u>\$3,671,559.98</u>		
		Total amount invested at Farmers & Merchants	\$43,138.78			
		Total amount invested at First Bank of Utica	\$3,359,504.02			
		Total amount invested at Cornerstone Bank, Waco . . .	\$68,415.86			
		Total amount invested at York State, Gresham	<u>\$200,501.32</u>			
		Total Invested	\$3,671,559.98			

School	Elementary Price	Secondary Price	Student Breakfast	Adult Breakfast	Adult	
Centennial	\$3.05	\$3.15	\$2.15	\$2.50	\$4.00	
Milford	\$3.00	\$3.25	\$1.60/\$1.75	\$2.85	\$4.70	
Sandy Creek	\$2.60	\$2.65	\$1.35	-	\$3.50	24/25
Fairbury	\$3.55	\$3.80	\$1.95/\$2.05	\$2.80	\$4.60	
Heartland		\$3.25	\$1.95	\$1.95	\$4.25	
Fillmore Central	\$3.00	\$3.35	\$1.85	\$1.95	\$4.10	
Sutton	\$2.90	\$3.10	-	-	\$4.60	
Thayer Central	\$3.15	\$3.35	-	-	\$4.60	
Superior	Free	Free	Free	\$2.75	\$4.75	
David City	\$3.90	\$4.10	\$2.15	\$3.00	\$5.00	
Average	\$3.14	\$3.33	\$1.89	\$2.54	\$4.41	
Milk	\$0.50					
Proposed Lunch Price Changes						
LUNCH	Elementary	Secondary	Adult			
24/25 Centennial	\$3.05	\$3.15	\$4.00			
25/26 Centennial	\$3.45	\$3.55	\$5.00			
<i>Conference Average 24/25</i>	<i>\$3.14</i>	<i>\$3.33</i>	<i>\$4.41</i>			
Estimated Average 25/26	\$3.36	\$3.55	\$4.73			
BREAKFAST	Student	Adult				
24/25 Centennial	\$2.15	\$2.50				
25/26 Centennial	\$2.50	\$3.00				
<i>Conference Average 24/25</i>	<i>\$1.89</i>	<i>\$2.54</i>				
Estimated Conf. Average	\$2.00	\$2.64				
Milk	\$0.65					

3000 Series M E M O

The 3000 series policies deal with Business and other General Operations of the district. This memo provides a brief explanation of each of the 3000 series policies.

Policy 3001. Budget and Property Tax Request. This policy deals specifically with creating budget and related requirements. The procedures outlined in the policy are required by state statutes, and have been updated to keep current with the most recent version of the statutes. It notes that the Superintendent is responsible for developing the budget.

Policy 3002. Deposits. This policy sets out general guidelines for how to handle money collected by the district. Note that the procedures outlined in this policy apply to anyone acting on behalf of the district, which includes employees, students and volunteers. Your board should determine the amount of cash that it is comfortable in keeping in the building overnight.

Policy 3003. Bidding for Construction, Remodeling, Repair, or Site Improvements. This policy sets out the process that the board will follow when it is going to solicit bids for construction and related projects.

The second section sets out the process that the District will follow when it is undertaking a construction project that has an anticipated cost of less than \$100,000. Under state law, school districts are only required to engage in the formal solicitation of bids when they are undertaking construction with a cost of more than \$100,000, but most districts want to follow some structured process for obtaining quotes or estimates before they begin smaller projects. This section also includes the ability for the district to use the ESUCC Coop for these non-bid projects.

The third section sets out the formal requirements of Nebraska's bidding statutes.

Policy 3003.1. Bidding for Construction, Remodeling, Repair, or Related Projects Financed with Federal Funds. This policy sets out the requirements that you must follow when you use federal funds for

construction. Please note that this policy will apply to any construction financed with federal funds, regardless of how much the anticipated project will cost. If the construction project has an anticipated cost of more than \$100,000 then you will have to comply with both policy 3003 and 3003.1.

Policy 3004. General Purchasing and Procurement. This policy sets out general guidelines for purchasing equipment and supplies which are not purchased with federal funds. Please review it carefully to be sure that it accurately describes your process in a general way. Note that there is a provision in this policy which states that use of statewide cooperative purchasing programs for school districts, such as ESUCC's Coop Purchasing, satisfies any requirement under this policy or state law to the extent such a bid or quote is not otherwise independently required by law.

The board must make a decision about two parts of the fourth section of this policy. You must tell staff how many days prior to a board meeting they have to submit receipts for reimbursement. You must also set the amount at which you will require staff to secure written quotes and/or estimates. Due to the way the federal regulations work, we strongly urge you to set that limit at \$10,000. As you will see, the EDGAR regulations have one set of rules for purchases under \$10,000, another set of rules for purchases between \$10,000 and \$250,000, and a third set of rules for purchase over \$250,000. We think it will be confusing for the district to adopt a fourth set of rules for purchases below \$10,000 but above some other limit set by the board. Having said all that, the board is certainly entitled to adopt a lower threshold than \$10,000 in this policy because it applies to purchases not made with federal funds.

Policy 3004.1: Fiscal Management for Purchasing and Procurement Using Federal Funds. This policy sets out all of the elements that are required by the Education Department General Administrative Regulations (EDGAR). These regulations apply to all federal grants that are made by the US Department of Education to local school districts directly and to all funds that pass from the federal government through state departments of education to local schools. That means you will need to follow this policy for purchases for your food program, special education, Title I and any other federal program. The first section recites that this policy will only apply to purchases made with federal dollars. This keeps your staff from having to jump through the hoops in this policy if they are spending state or local funds. All of your staff who work in areas where federal funds are spent (cooks, special ed and Title I paraeducators, etc.) should be trained on this policy.

Policy 3005. School Activities Fund. This policy governs school activity funds and it provides that funds remaining after graduation may be

transferred to any district account. Notice that this policy attempts to address the problem of unspent senior class funds by permitting the funds to be transferred at the board's discretion or kept in that class's fund. If your board follows a different practice, contact us or your regular school attorney to be sure that your practice is lawful.

Policy 3006. [Intentionally Left Blank]

Policy 3007. Review of Bills. This policy provides a good set of checks and balances which is always a subject of focus for the State Auditor. If your school district follows a different process, please let us know and we can draft a custom policy that describes your district practice.

Policy 3008. Gifts, Grants and Bequests. Although it is generally a good thing when people want to give the school district donations, boards need to have control over what is donated and how it is used. This policy allows the superintendent to accept the donation of personal items (like coats for a winter closet drive) and of cash donations up to a limit set by your board. We generally recommend that the limit be around \$10,000, although you can change that to whatever amount your board prefers. Donations valued more than this amount must be approved by the board.

Policy 3009. Audit. This policy states that you will obtain an annual audit as required by law. It also states that the district does not use generally accepted accounting principles. Most schools do not have the staff or other resources to comply with GAAP and state statute specifically provides that schools do not have to follow GAAP. Nonetheless, the state auditor will frequently criticize schools for not following GAAP. This policy will help schools defend against that sort of criticism.

Policy 3010. Insurance. This policy addresses insurance as it relates to protecting the school district, the board as a corporate body, individual board members, appointed officers, employees, and volunteers from financial loss arising from any claim, demand, suit or judgment. The school district's insurance should be reviewed annually or as the need arises.

Policy 3011. [Intentionally Left Blank]

Policy 3012. School Meal Program and Meal Charges. This policy complies with the federal regulations which require you to describe your meal program for students and the meal charge policy. The "Meal Program" section outlines the district's responsibilities to create a program, set costs, and/or contract with a private company to manage the program. Your board must select the options available within your district for families to pay for student

meals. Be sure to delete the options which do not exist within your district. The policy also states that the district will notify families of the costs and the procedure for signing up for free or reduced-price meals. The "Meal Charge Policy" outlines the district's duty under federal regulations to establish procedures and provide notice for how the school will handle student meals when a student's meal account is delinquent. We have provided four options. Your board must choose one and delete the other options.

Policy 3013. Emergency Closings. This policy on emergency closing states that school will be held on each day of the school calendar unless the superintendent determines that school should not be in session. Note that the policy uses the "impossible or impracticable" wording from the mandatory attendance statute, which should support the district if a parent ever claims bad weather as a defense to a truancy charge.

Policy 3014. Use of School Property. Over the last several years, schools and ESUs in Nebraska have seen an increase in the variety and frequency of groups wanting to utilize district facilities. Districts in Nebraska and throughout the country have been involved in significant litigation regarding facility use, and many others have been forced to resolve facility use questions with entities like the ACLU. In response, our policy takes a comprehensive look at these issues.

Accounting for "Regular Uses." Many districts permit patrons to use facilities such as the weight room and track on a regular basis. Some districts have designated hours, and others permit patrons to keep keys or fobs to access the facilities. Most districts use some sort of application and agreement for these uses separate from their general facility use application. The first section of the policy is an attempt to capture these regular, individual uses and permit them with only one application. We have also included an Application, Release, Waiver, and Agreement document. Rather than requiring patrons to apply for a facility use permission every time, we hope this one-time application process protects the district to the maximum extent possible and eases the administrative burden when patrons use the facilities regularly.

Prohibiting Commercial Use. This is a very tricky area for many districts. Most districts do not want to turn the school and school activities into shopping malls. However, most schools do want to permit booster clubs and student groups to raise funds which support school students and activities. From a purely legal perspective, the district is almost always better off prohibiting others from profiting by using district facilities. One recent example is an athletic trainer who wanted to host a workout class in the school weight room and charge money for patrons to attend. The trainer sought to take advantage

of the facility being open to community use and planned to use the district's equipment and facilities rent-free to host the class. As a result of requests like this, we have written the policy to prohibit commercial uses which result in personal financial gain. If your district has a practice of permitting commercial uses, such as fitness classes, for-profit craft fairs, and other such events, you should contact us directly to assist you in preparing a policy provision which best protects the district.

Redefined Groupings. The policy breaks out groups using facilities into four separate categories: curriculum-related student groups, extracurricular student groups, non-curriculum related student groups, and non-student groups. This grouping system closely tracks the Supreme Court cases and assists in drawing clearer lines for requirements of various groups depending upon their alignment with district curriculum and activity offerings. For example, the policy says that all student groups are given priority over other outside groups.

Charging Fees for Admission. The last section of the policy prohibits groups which use school facilities from charging admissions fees. This is a *major* question in many districts, and our provision may not be consistent with your district's practices and preferences for supporting your community groups. **Please read this section carefully and be sure to discuss it fully with your entire board.**

The Political Subdivision Tort Claims Act exempts schools from liability when their facilities are used for "recreational" purposes, but only if the group using facilities does not charge a fee to participate in or spectate the event. Likewise, if the district maintains control over the event/facilities, such as providing supervision or custodial services, the protection from liability may not apply.

These protections came about as a result of court cases where political subdivisions were sued because someone attending an event held in public facilities was injured. In one case, for example, a patron suffered an ankle injury stepping in an animal burrow on a courthouse lawn during a town celebration. The public policy behind these protections says that schools should be encouraged to permit others to use their facilities. As an incentive to permit the recreational use of district facilities, school districts should not be held liable for damages suffered when patrons are participating or spectating "recreational" activities on school grounds. The definitions in the statutes are quite broad, providing protection to schools in many cases.

However, in order to maintain the protections of this law, schools cannot permit outside groups to charge a fee to attend the facility and cannot

maintain control over the facility. If someone has to pay a fee to attend an activity, and if the district maintains control over the facility, then the patron(s) has a greater expectation of protection from possible dangers. But if the school does not maintain control and the entity using the facility does not charge an admission fee, the district is only liable for its "gross negligence" rather than standard negligence.

As you can see, this is one of the more complex policies in our service. Please feel free to call us and work through these issues one-by-one whenever it is convenient for you.

Policy 3015. Time Away From School Activities. This policy states that school activities will not be held on Wednesday nights or Sundays. This policy intentionally considers these days "time away from activities" and specifically and intentionally does not contemplate the types of activities in which students may be engaged on those days. **If you have other days designated for time away from school activities, modify the policy accordingly. Likewise, if you do not have days on which district refrains from scheduling school activities, you may elect not to adopt this policy.**

Policy 3016. Smoking and Related Products. Many districts are struggling with effective policy solutions to electronic cigarettes, vapor pens, and similar technology. It is a criminal violation for any minor under the age of 18 to use "vapor products or alternative nicotine products." Accordingly, we recommend that your general tobacco use policy include an option which prohibits the use of vape pens, electronic cigarettes, and the like. While this policy applies to all students and staff, it applies generally to all district patrons and visitors. **This policy has 3 options. You should select one or a combination of these policies.**

Policy 3017. Official Communication with the Public. This policy requires administrative approval of press releases and other official communications with the public. Over the years, staff members have occasionally taken it upon themselves to communicate with the public or media on behalf of the district during a crisis or other time when they should not have been the one communicating. This policy is very useful to clarify that only individuals with prior administrative approval have the authority to speak for the district to the media. By limiting it in that way, it also reduces the likelihood of a First Amendment challenge if one of the school's social media accounts, like "Greyhound Wrestling," blocks a negative comment or commenter.

Policy 3018. Denial of Access to School Premises. This policy provides a method for denying access to school activities or school premises. It permits

an administrator to limit or deny access to certain school activities or school premises for various reasons.

Policy 3019. Sale or Disposal of School Property. This policy states that the sale of school property must be made with the best interests of the school and taxpayers in mind. It sets forth the statutory requirement that the sale of school property be approved by a two-thirds vote of the board of education at a regular board meeting.

Policy 3020. Copyright Compliance. This policy addresses copyright compliance and discusses the steps district administrators must take or may take when an infringement occurs. It states that teachers and students may not use any media in a manner that is in violation of applicable copyright laws. If staff or students subject the district to payment for copyright violations, the district may require the offending student or staff member to make the district whole. **Please note: even if there is a technical infraction which occurs because of a staff member or student, one protection for educational institutions against copyright liability is to distribute materials and provide training to staff and students about the importance of copyright compliance. This policy requires you to distribute materials to students and staff for the purpose of preserving that defense.**

Policy 3021. Operation of School Business Office. This policy describes the days and hours that the business office will be open. Some boards prefer that the district's business office be open during regular business hours. **You should revise the policy to describe the district's practice.**

Policy 3022. Volunteers. This policy addresses the use of volunteers. We recommend having most volunteers sign a volunteer services agreement, though we recognize that in some instances the volunteer's involvement will be insubstantial. The policy also prohibits people from volunteering if they refuse to comply with a requested background check. If you need assistance in creating or updating your volunteer services agreement, we would be happy to help.

Policy 3023. Record Management and Retention. School districts must comply with two sets of laws governing the retention and deletion of records. The Federal Rules of Civil Procedure require government entities to retain some electronic records with metadata intact and to state with specificity when they will delete electronic records. Nebraska's Records Management Act and the record retention schedules adopted by the Nebraska Secretary of State's Record Management Division outline when schools may delete both physical and digital records. The schedules which apply to school districts are Schedule

10 and Schedule 24. This policy outlines how the school district will comply with all of these various laws and regulations.

This policy has several options for you to consider. You should select the option that describes your practice and delete the other options.

If you use a cloud-based service such as Google Apps for Education or Office 365, you will need to select the retention level you have selected from your service provider. If you still use internal servers to host your e-mail, you will need to consult with your technology coordinator to determine how long the district stores e-mail and other electronic data. There is no obligation to retain all of your e-mail in their original format, but you must identify your retention schedule for these records.

Under Schedule 24, "short term communications" must be maintained for at least 6 months, which is why we have included that retention period for school-affiliated social media posts. Please note that all this means is that staff using school-affiliated social media posts cannot delete their posts for at least 6 months. If you use Twitter, for example, to announce sports scores, you just cannot go back and delete old Tweets at the end of the school year. You do not have to print these posts -- leaving them on the social media application counts as "maintaining" under the schedules.

Your retention obligations for security video is covered by Schedule 24. After consulting with the Secretary of State's office, we have categorized security video as "working papers" which can be destroyed as soon as the school determined that there is no need to keep it. Schools will have to complete an annual disposition report regarding this footage. The Secretary of State's Office was gracious enough to provide us with a sample disposition report on security video footage, which we have included as an example with the forms for the 3000 series.

Policy 3024. Booster Clubs and Parent-Teacher Organizations. There are two completely separate policies offered for your consideration to govern your relationship with these groups. You should adopt only one of these policies. Regardless of the policy you select, we suggest that the district: (1) take complete control over the organization's finances or (2) keep the school's finances and the organization's finances completely separate. Regardless of which approach is used, the key is to make the relationship clear in the policy. We have attached policies which address both situations.

Policy 3025. Returned and Outstanding Checks. This policy deals with insufficient fund checks. It states that a person who wrote a bad check must pay the school the amount of the check in cash plus an additional \$30 (the

board should choose the amount; \$30 is standard in Nebraska) to cover costs to the district. It also gives the district the authority to refuse to accept checks from people whose checks are repeatedly returned for insufficient funds. The policy also addresses checks which are outstanding and authorizes the superintendent to review them and resolve any issues related to outstanding checks, including stopping payment and reissuing the checks. **These terms are not statutorily required and the board may set its own standards.**

Policy 3026. Handbooks. This policy covers handbooks. It states that handbooks are intended to convey information and explain school regulations and procedures. It points out that the handbooks are not contracts and that the administration has the authority to change handbook provisions during the year so long as the changes are consistent with board policy. It also makes clear that the handbooks are trumped, when inconsistent, by board policy and state law.

Policy 3027. Resolution of Conflicts Between Parents Over School Issues. This policy addresses the resolution of conflicts between parents over school issues. It explains that the school will not become involved in disputes between parents regarding such issues as court orders, student records, and picking up children at school.

Policy 3028. Sex Offenders. This policy deals with sex offenders and emphasizes the importance of students' safety at school. The second paragraph of this policy is not legally necessary but it is recommended. It states that the school will notify staff members, parents, and students (1) of any registered sex offenders residing in the school district and (2) of the availability of information about sex offenders on the State Patrol's web page. If your district does not distribute this list to staff, parents, and students, you should.

Policy 3029. Distribution of Flyers Advertising Non-School Issues. This policy addresses the distribution of flyers advertising activities of non-school organizations. The first numbered paragraph sets forth prohibitions against flyers with statements that are inappropriate for a school setting. The remaining paragraphs set forth procedures and requirements for flyers.

Policy 3030. Automatic External Defibrillator (AED) Program. Some organizations offer to donate both the AED and the cost of its upkeep. The attached policy is designed to limit the school district's potential liability while incorporating the policy elements recommended by the American Medical Association and the American Heart Association. You will have to identify a medical advisor and should be sure that the person designated as the AED Program Coordinator understands his/her obligations under the policy and is

willing to fulfill those responsibilities. **Note that you will have to identify a Program Coordinator and Medical Advisor.**

Policy 3031. Students Electing to Attend School in Adjoining State.

This policy addresses requests for students to attend schools in an adjoining state. It restricts approval of out-of-state enrollment except when (1) the student will suffer extreme and unusual harm if not allowed to attend school in an adjoining state; or (2) the district's financial circumstances will be unaffected by the out-of-state transfer.

Policy 3032. Fees for School District Records. This policy addresses the fees for obtaining school district records should they be requested. It is important that you set these fees so that you can charge an appropriate amount for voluminous public records requests that more and more Nebraska school districts have faced recently. **You will have to identify what amount you will charge for each request, and it must be based on actual costs for things like computer run time, paper, toner, etc.**

Policy 3033. [Intentionally Left Blank]

Policy 3034. [Intentionally Left Blank]

Policy 3035. Chain of Command. This policy was created in response to requests from several of our school district clients to provide more effective and efficient assistance to patrons and employees with questions or concerns. You should review this carefully to be sure it accurately describes how your district's chain of command operates.

Policy 3036. Purchasing (Credit) Card Program. Many school districts in Nebraska use credit cards to purchase goods and services for school purposes. However, many schools are unaware that, though state law authorizes the use of such credit cards, it also imposes certain obligations upon the district. In addition, the Nebraska Auditor of Public Accounts has chastised some schools in their audits because school personnel failed to maintain adequate supporting documentation for credit card expenses in violation of state law and school district policy. This policy includes everything required by state law and incorporates recommendations made by the State Auditor in previous school district audits. It also tracks changes to federal purchasing and procurement and allows continuity of your purchasing system. **Please note that there are several blanks that your board must fill in on this policy.** After you adopt the policy, we strongly encourage you to provide a copy of it to all employees and require them to acknowledge that they have received and read it.

Policy 3037. Petty Cash. The Nebraska State Auditor has expressed concern during school audits that a school district maintained a petty cash fund without adopting any policy or procedures governing its use. The auditor was particularly concerned about the lack of monitoring and oversight of the fund. **If you do not use petty cash, you do not need this policy.** However, if you do utilize such a fund, we strongly encourage you to adopt a policy that spells out its amount, who controls it, when it may be used, monitoring procedures, etc. You should review this policy with the administration and the board to make sure that it conforms to your actual practice. **Please note that there are several blanks that your board must fill in on this policy.**

Policy 3038. [Intentionally Left Blank]

Policy 3039. Threat Assessment and Response. Schools are required to have a “threat assessment” procedure which they are supposed to use any time someone reports a threat made by a student, staff member, or patron. The idea is that the school can use a data-driven approach to determine what to do in response to such a threat rather than a knee-jerk reaction. **There are three options in this policy** - one in which a “threat assessment team” investigates and responds to threats; one in which the superintendent performs these tasks alone; and one in which a school district law enforcement unit conducts the investigation. **You should select the option that best reflects your district’s practices and delete the other options.** However, you cannot use the “law enforcement unit” option unless you have adopted Policy 5054, designating a “law enforcement unit” for your district.

Policy 3040. School Safety and Security. We have designed this policy so that it complies with the NDE Safety and Security Protocols. The first section states that the board wants to meet the minimum safety requirements. If your board wants to go beyond the minimum to meet the “exceeds” or “outstanding” level of the rubric, please let us know and we will revise these policies accordingly.

In the next two sections of this policy, we have tried to separate out the obligations for safety and security measures between the superintendent, principals, and the crisis team. You may revise **who** must perform each of the duties identified, but you may not **eliminate** any of these duties and still comply with the Safety and Security Protocols.

This policy also contains options for your board to consider in allowing memorials on school grounds or at school events. **Your board should carefully review the section of the policy dealing with memorials and select which option will best fit your district’s needs.**

When a school community experiences the death of a student or a similar tragedy, there is often the very human tendency to want to do something in memory of the deceased student. Pursuant to guidance from the School Safety and Security division of the Nebraska Department of Education, we have included a provision on school memorials in Policy 3040 School Safety and Security.

We have included two options for memorials in this policy. The first is to flatly prohibit them. The second option sets up a process whereby the school's crisis team can consider a request for a memorial and make a recommendation to the board. It is important that you discuss this issue as a board **now** before a crisis event has occurred.

While it may seem heartless, we prefer that your board prohibit memorials. There are a few main reasons why a public school district allowing memorials is troublesome. The most significant reason to disallow memorials is that multiple studies show that it is detrimental to students' wellbeing. Research shows that memorials can delay grieving and that things like memorials and media coverage of suicides can contribute to copy-cat deaths. For example, The Society for Prevention of Teen Suicide notes,

"[T]he logic of dying by suicide so that the school will put up a plaque or hold an assembly to acknowledge the death is almost impossible for most of us to comprehend, [but] it is the way suicidal students can think."

The school district does not want to foster an environment where suicide becomes a response to any of life's difficulties for school-aged students. However, it is impossible to disallow memorials for some deaths yet allow them for others. For example, a student death due to a car accident or terminal illness could receive an outpouring of support, while a student suicide generates a muted response due to the school's desire to minimize the impact of suicide among the student body. In our experience, many boards have come to the logical conclusion that if you do not want to allow memorials for all deaths given the psychological research, the only option is to prohibit all of them.

From the purely legal side, another difficult issue is the fact that memorials almost always create a "forum" where First Amendment issues and questions of "equal treatment" arise. For example, if a student memorial includes a Bible verse at the request of parents, another set of parents could ask for some type of quote, verse, or message which a majority of your community would disagree with. Prohibiting a memorial or even the proposed text on a

memorial based on the speaker's viewpoint or content of the message would directly violate the First Amendment. As with most questions of access and speech in public schools, if you allow one idea, you most likely have to allow them all.

Similarly, allowing memorials puts the school in the position of determining whether the scope of a memorial is appropriate or "fair." For example, requests for memorials have ranged from a moment of silence, to a small plaque on a bench, to a full statue. In some cases, the financial status of the family has impacted the request to the point where the school district has been asked to pay for it. Unless the school district is very specific about prohibitions or at least limitations on memorials, it will almost certainly invite requests which become more elaborate and unique with each family. Weighing these requests can be politically, legally, and practically difficult.

With an eye toward student mental health and avoiding other difficult issues, we encourage our clients not to allow student memorials.

If your board elects to allow them, we have provided a process in policy 3040 through which your crisis team reviews and analyzes requests for memorials.

The school district can and should support students who wish to attend student memorials by allowing any student to attend a memorial service and receive an excused absence. Grief counseling and other support should also be made available as appropriate. Before you commit other resources of the school district toward any response to a tragedy, such as sending flowers to a funeral, or toward a memorial; you should first be sure it is authorized by state law (...and in many cases, it's probably not).

We understand that circumstances in which requests for student memorials arise are incredibly difficult. That is exactly why we'd like to walk through these issues so your board and administration can discuss your current policy and feel prepared to handle questions from students, parents, patrons, and the media should tragedy strike in your school district.

Policy 3041. Crisis Team Duties. This policy places the majority of the responsibility for complying with the Safety and Security Protocols on the crisis team. Note that the superintendent names people to serve on the crisis team using the considerations set out in policy 3040 above. The way this is set up, it will be the crisis team that conducts the self-assessment required by NDE. All of you currently have an All-Hazard School Security Plan. It is likely that the Safety and Security Protocols will require substantial revisions to that plan, and this policy places the responsibility for those revisions on the crisis team.

Again, we have not included anything in this policy which is not required for minimum compliance with the Safety and Security Protocols.

Policy 3042. Construction Management at Risk Contracts and Policy 3043. Design-Build Contracts. The Political Subdivisions Construction Alternatives Act requires a school to have policies in place before it can use the construction management at risk and design-build methods of construction. These policies comply with the requirements of the Act.

Policy 3044. Incidental or De Minimis Use of Public Resources. The general rule is that personal uses of “public resources” are not permitted. However, the Nebraska Political Accountability and Disclosure Act allows boards or public entities, such as schools and ESUs, to pass a policy which authorizes board members and employees to use public resources for personal purposes when those uses are “incidental or de minimis.” As long as the personal use is accounted for on the board member’s or employee’s personal taxes, as required by law, the board can authorize these uses to avoid complaints and allegations of misuse. This policy is designed to account for the most common uses we come across, and your board is free to remove or add additional uses consistent with your practices.

Policy 3045. Use of Sniffer Dogs. Many schools have decided to use trained drug dogs to conduct “sniff searches” of vehicles on school grounds, school lockers used by students, and other items or areas at the school. Schools have the authority to use drug dogs to conduct “sniff searches” in many, if not most, circumstances. One exception is the use of a dog to sniff a student or staff member. **We strongly discourage school districts from allowing dogs to sniff people.** The tougher questions are whether the school *should* implement the use of drug sniffing dogs and, if so, how the program should be implemented. This policy includes our recommended procedures in the event that the school decides to use drug dogs.

Policy 3046. Animals at School. This policy addresses animals on school grounds from all relevant legal perspectives: class pets, therapy animals, and service dogs. The requirements for each are different, with the key being the disability-related considerations for therapy animals (which can include nearly any animal) to service dogs (which include only specially trained dogs and miniature horses). The policy also requires that requests for service animals and requests for therapy animals (where you allow them) that are made by or on behalf of a student with an IEP or a 504 plan be referred to the respective IEP or 504 Team for consideration. **There are two options for therapy animals, and you will need to pick one and delete the other.**

Policy 3047. Data Breach Response. School districts that are required to provide reasonable security to personal information handled by the district. This policy states the district will implement the appropriate security, and if the district experiences a data breach it will investigate the breach, provide notice to those affected, and notify the Attorney General. We have also included a section that provides for data governance protocols to be put in place to map the flow of data between software, hardware, and personnel in order to maintain good data hygiene and make sure data breach responses will run smoothly and efficiently.

Policy 3048. Communicable Disease. This policy sets forth steps to take if it is determined that a staff member or student has a high risk communicable disease. Because we get this question all the time, we did want to highlight that, yes, Hepatitis "E" is a real thing included in the DHHS regulations.

Policy 3049. Drones and Unmanned Aircraft. With the increasing use of drones and other unmanned aircraft by schools and by private individuals, this policy contemplates some general use restrictions while also factoring in differences for district uses versus personal or private use on school grounds. The policy generally defers to the superintendent or his or her designee to provide permission, designate authorized areas, and impose other restrictions on the use of drones on school property.

Policy 3050. Technology in the Classroom. This policy addresses the use of electronic devices and software applications in the classroom that are not selected or purchased by the district. If a teacher brings in a Google Home, Amazon Echo, or similar device; or wants to use a specific application; this policy requires that the teacher notify the administration of the device or application's use, and provides guidance on how the device should be setup. The policy also restricts the use of assistive technology to prohibit the recording and transmitting of the classroom activities of other students.

Policy 3051. Opioid Overdose Prevention and Response. Naloxone, also known by its brand name Narcan, has been used by emergency responders and health care professionals for many years as an opioid antagonist to reduce deaths and negative consequences of individuals experiencing opioid overdose. Although Nebraska has a naloxone statute allowing for dispensing naloxone without a prescription, the Department of Health and Human Services, Division of Public Health, has also issued a standing order to facilitate the availability of naloxone. This policy allows the district to take advantage of those laws and have naloxone available to administer by appropriately trained staff. Much like the policy on AED's, it is permissive and you should consult with your school nurse and local authorities if you want to have a naloxone program.

Policy 3052. Leasing Personal Property. This policy provides the authority for authorized personnel to lease personal property (e.g., equipment, goods, etc.) from vendors for school district use. **A decision will need to be made as to the total lease amount above which written quotes/estimates will be required to be obtained from multiple vendors.**

This policy also provides the authority for the Superintendent to lease out district-owned personal property that is not needed for school purposes. **The board will need to decide (1) the threshold (dollar amount) of the fair market value of the personal property in question under which the Superintendent may lease out such property without board authorization, and (2) the maximum number of days that the Superintendent can agree to lease out district-owned personal property.**

Policy 3053. Nondiscrimination. This policy satisfies the requirement that a school district have a policy which forbids discrimination for unlawful reasons.

School districts with 50 or more employees are required to appoint a responsible person to coordinate the administrative requirements of ADA compliance and to respond to complaints filed by the public. In this policy, the 504 coordinator is the same person as the ADA coordinator. If you do not want your 504 coordinator to serve as your ADA coordinator let us know and we can work with you to customize this policy.

Policy 3054. Law Enforcement Unit. This policy allows the board to designate a law enforcement unit for the district. The district is permitted to designate any individual or group as its law enforcement unit. The disclosure of records created and maintained by a law enforcement unit for a law enforcement purpose is not restricted by state and federal student record laws, so this policy further outlines how law enforcement unit records should be maintained and how they may be disclosed. **Designating a law enforcement unit implicates complex legal and privacy considerations, and we encourage you to reach out for advice on these issues before adopting this policy.**

Policy 3055. School Resource Officers. Nebraska state law requires schools have a memorandum of understanding in effect with any law enforcement agency that provides school resource officers and any security agency which provides security guards to schools in a school district. Each MOU must include policies that address six specific issues. We have developed

this policy to ensure that every policy provision required by the new SRO statutes exists and can be incorporated into any MOU.

Policy 3056. Guest Speakers. Some schools have invited guest speakers into school with little to no knowledge of the guest speaker's message, experience, or intent. Not surprisingly, not all guest speaker appearances went as smoothly as one would hope when there is little research done about the guest speaker. This policy includes a process and procedure to research guest speakers so that everyone involved has a clear understanding of the guest speaker's purpose and message. This will help the school determine if the proposed message complies with school district policies and its fundamental values and to avoid unwanted surprises for everyone involved.

Policy 3057. Title IX. This policy is required by federal regulations, including all of the components of the "grievance process" laid out in those regulations. The policy includes the applicable definitions, procedures, and obligations of the district under Title IX. This policy must be posted on your website in a prominent location, and a short notice of this policy must be in all handbooks, newsletters, and other communications of the district.

Policy 3058. Naming School Facilities and Property. This policy is optional, and you are not required to adopt the policy unless you believe you will undertake a project or receive a request for naming rights. If you have already sold or given naming rights away, you should ensure this policy does not impact any existing agreements or obligations. We have included this policy within our service at the request of several subscribing schools. There are multiple ways to create such a policy. Our model policy attempts to provide as much flexibility to boards as possible while also being mindful of legal complications that can arise when schools permit outside individuals or entities to have control over naming rights within schools, such as on building facades or within certain rooms or areas of school buildings.

Policy 3059. Audio and Video Recording. This policy clarifies when staff, for educational purposes, or students for any purpose may make audio or video recordings at school, in a school vehicle, or at school activities. It also clarifies that the district may make audio and video recordings for things like safety and security, but that those recordings will not be maintained unless specifically copied and saved. Finally, it places limits on when others, such as parents or patrons, may make recordings. It specifically limits the ability of a parent to record things like IEP meetings.

Policy 3060. Firearms and Weapons for Non-Students. This policy lays out the prohibitions and exceptions for non-students possessing firearms on school grounds. The general rule is that firearms are prohibited. There are

several exceptions, including for on- and off-duty or retired law enforcement. Those apply to all Class I, II, and III school districts. This policy is designed for that purpose.

For Class I and II school districts beginning January 1, 2025, boards may permit employees and other “security personnel” to possess a firearm on school grounds, in school vehicles or at school events. This policy is not what you will need to permit that. If your district wants to consider such a policy, we will help prepare it for you. That type of policy must include, at a minimum, requirements for personal qualifications, training, appropriate firearms and ammunition, and appropriate use of force. The State Board of Education and Nebraska State Patrol will develop a model policy for that purpose.

KSB’s advice is not to allow employees or others who are not trained law enforcement or former law enforcement to carry firearms on school grounds, for a number of reasons. It is unclear whether school insurance companies will or will not cover schools that allow it. We are also concerned about liability and safety issues. However, your school board and administration get to make the call. If you want to consider this as an option and are a Class I or II school district, please reach out to us.

3028 Sex Offenders

The safety of the students attending school is very important to the board of education. School employees, parents, and students should be aware of dangers posed by sex offenders living within the school district, and should be vigilant in providing protection against these dangers.

~~The Nebraska Legislature has enacted the Nebraska Sex Offender Registration Act. The Act requires sex offenders to register with the local county sheriff where they reside. The school district shall notify staff members, parents, and students of any registered sex offenders residing in the school district. Such notice shall contain information about the availability of further information on the State Patrol's web page, and shall inform the recipient of the prohibition against using the information for any retaliatory purpose against the sex offender, the offender's family, or the offender's employer. Only information deemed non-confidential pursuant to NEB. REV. STAT. §§ 29-4006 and 29-4009 will be disclosed in the aforementioned notification.~~

The board does not generally permit registered sex offenders on school grounds, at any school sponsored activity, or on any property under the control of the school district. The superintendent or his/her designee is hereby empowered to notify sex offenders of this policy and to grant limited permission to attend certain activities on a case-by-case basis.

Students who are registered sex offenders shall not be precluded from receiving a free education from the school district on that basis. The school district will consider a student's status as a registered sex offender in determining the student's educational placement and program.

Adopted on: 2/13/2017
Revised on: 7/8/2019
Reviewed on: 1/10/2022, 5/8/2023

3014 Use of School Property

1. Use of Specific Facilities by Application and Agreement

- a. The district permits non-commercial use of the following facilities by individual patrons for their personal health and wellness: weight room, old school gym, and track. The district understands that it would not be feasible to require a patron to apply to use facilities like the weight room on every occurrence. The facility uses defined in this paragraph are an exception to the general facility use requirements contained in this policy for ease of administration and efficiency. All other facility uses must comply with the other provisions of this policy.
- b. These particular facilities may be used upon only one application and upon signing the district's written waiver and agreement.
- c. Use of these facilities is governed by this and other district policy and the agreement signed by the user. A copy of each agreement will be maintained in the district's central office.

2. General Facilities Use Guidelines

- a. School facilities may be used by various education and community organizations and individuals when it is in the interest of the general public.
- b. School facilities may not be used for personal profit and other commercial purposes. The district opens its facilities to district patrons for the benefit of the public, not commercial uses. Due to the complications created by groups or individuals using district facilities for commercial purposes, these uses are prohibited. Booster clubs and other organizations raising money purely for the support of student groups, as defined below, and not for personal profit are not considered commercial uses but must comply with the district's policies which apply to these groups.
- c. Any person or group using school facilities must assure that it will be responsible for maintaining order, protecting property, and providing security and safety.
- d. Only those organizations and persons who are known to school officials, who have financial resources sufficient to cover all rentals and possible damages, and who are willing to discharge such obligations shall be permitted to use the school facilities and equipment.
- e. The rental fees for school facilities shall be set annually by the board.
- f. Non-curricular student groups or non-student groups (as those terms are defined below) that wish to use the facility must submit a facility use application which

may be obtained from the district's central office. The application must be received by the superintendent prior to the approval of any facility use.

- g. The shop and weight room may not be used by students when school is not in session, unless supervised by a district staff member or a responsible adult upon approval of the Superintendent. Use of the shop and weight room in violation of this provision may lead to the students being denied access to these facilities or other consequences permitted by board policy and Nebraska law.
- h. Any person or group using the school facilities, for any purpose, must comply with all of the district's policies, rules, and regulations.

3. Definitions

- a. "Curriculum-related student groups" shall mean students participating in school-sponsored activities, supervised by district staff, related to the curriculum, and recognized by the board.
- b. "Extracurricular student groups" shall mean students participating in an extracurricular activity, sponsored by the district, supervised by district staff, and recognized by the board, such as athletic teams and academic teams which are not otherwise categorized as "curriculum related student groups."
- c. "Non-curriculum related student groups" shall mean all other groups composed primarily of students who attend the district participating in activities such as Boy Scouts, Girl Scouts, 4-H, political groups, religious groups, and other similar youth groups.
- d. "Non-student group" shall mean all other groups or individuals who apply to use district facilities.
- e. "Superintendent" shall mean the superintendent of schools or his/her designee.

4. Use of School Property by Student Groups

- a. Curriculum-related and Extracurricular student groups
 - i.) Curriculum-related and Extracurricular student groups may use school facilities at no cost to the group, if they restore the facilities to their prior state after using them.
 - ii.) The district shall bear any costs associated with use by these groups (e.g., the fee paid to a cook or a custodian required to be in attendance).
 - iii.) Curriculum-related and Extracurricular student groups have priority over non-curriculum related student groups and non-student groups.

b. Non-curriculum related student groups

i. Non-curriculum related student groups may use the school building during non-instructional time. Such use shall be without charge.

(1) Such uses shall occur while the building is normally open and there is a minimum of interference with custodians or other student and staff facility use.

(2) These groups may use the school buildings in the evening for meetings if the group is sponsored by an adult and the adult (1) files the application to use the facilities on behalf of the group and (2) assumes responsibility for cleanup and placing the area back in the condition it was in prior to use.

ii. Non-curriculum related student groups must apply for use of the facilities and secure the superintendent's permission before using school facilities.

iii. Non-curriculum related student groups may meet only on school premises at times and places determined by the superintendent.

iv. Non-curriculum related student groups must meet each of the following conditions to secure the superintendent's permission to use school facilities:

(1) The facility use will occur during non-instructional time.

(2) The district has facilities available to accommodate the group.

(3) The use is voluntary and for the general benefit of the student participants.

(4) The use will not substantially interfere with the orderly conduct of educational activities and other programs within the school.

5. Use of facilities by non-student groups

a. The superintendent may authorize the use of any school facilities for non-school activities by non-school groups.

b. In addition to the guidelines listed elsewhere in this policy and other board policies or administrative protocol, the superintendent will consider the following when making determinations regarding use of district facilities by non-student groups:

i. The local education association may hold meetings when classes are not in

session and staff members are not on duty.

- ii. Non-student groups which provide education-related programming and services for students and staff may be given priority of use over other outside groups. The superintendent has sole discretion in determining whether proposed uses relate sufficiently to the district's educational standards and programs.
- iii. Non-student groups which provide programming and services for community members and others living within the district may be given priority of use over other outside groups.

c. Denial of access

- i. The superintendent may limit or deny access to school buildings, grounds, and activities to any person whom the superintendent deems to be using the facilities inappropriately and contrary to the district's mission.
- ii. Upon determining that a person or group has engaged in, or is engaging in conduct that constitutes grounds for exclusion under this policy, the superintendent shall take such action as he or she determines appropriate, including directing the person to cease engaging in the conduct or to leave the school premises or activity immediately. The superintendent may request assistance from law enforcement authorities to remove an offending person from the school grounds. A person who enters school premises in violation of these conditions shall be deemed to be trespassing.
- iii. The superintendent shall have the authority to fix the time when, and the conditions under which, the offending person may return to school premises.
- iv. Students, faculty, and community members may use or lease school equipment for non-school use only if they have received the prior permission of the superintendent.

7. Proof of Insurance

- a. When any non-curriculum related or non-student group utilizes school district facilities, the group submitting the facility use application may be asked to provide proof of insurance up to the current tort claims limits applicable to political subdivision in the State of Nebraska. Currently, those limits are \$1,000,000 per person for any number of claims arising out of a single occurrence and \$5,000,000 for all claims arising out of a single occurrence.
- b. The district may require the non-curriculum related or non-student group to include the district as an additional insured on any such policies and may refuse access to its

facilities until proof of satisfaction of this requirement is submitted to the superintendent.

8. Fees for Admission

- a. Non-curriculum related and non-student groups may not charge a fee to participate in or be a spectator at any recreational activity, event, or other such gathering occurring on district grounds unless approved in advance by the superintendent.
- b. If the district retains control over the area of the premises in which the non-curricular and non-student group desires to use, meaning the district provides supervision, staffing, custodial services, or otherwise maintains its control during the group's use of the facilities, the group may not charge a fee for admission under any circumstances.
- c. Non-curricular and non-student groups may charge for parking or vehicle entry onto the premises unless otherwise prohibited by the superintendent.

Adopted on: 2/8/2016

Revised on: 2/14/2022

Reviewed on: 4/10/2023

Admission Prices Proposal

Centennial Public School

Empower, Challenge, and Support Every Student, Every Day

May 2025

2024-2025 Admission Prices for Activities

Individual Game Admission	Price
Students	\$5 (Centennial & St. Paul Students Free)
Parents	\$7

Yearlong Pass	Price
Individual	\$65

PROPOSED 2025-2026 Admission Prices for Activities

Individual Game Admission	Price
Students	\$5 (Centennial & St. Paul Students Free)
Parents	\$7

Year Long Pass	Price
Individual	\$75

Area School Year Long Pass Comparison (24-25)

School	Price
Milford	\$60 Individual; \$120 Family; K-6 \$45
Fairbury	\$70 Individual; \$180 Family; \$40 Student
David City	\$80 Individual; Students Free
Fillmore Central	\$75 Individual; Students Free
Heartland	\$75 Individual; \$180 Family, \$50 Student
Wilber-Clatonia	\$50 Individual per season or \$150 All Year

CENTENNIAL GRADUATION REQUIREMENTS

The Centennial Board of Education believes the many benefits of a high school education cannot be fully realized in less than four years. Further, it views the entire senior year as an important period during which the student should be able to enjoy many experiences providing academic growth and enrichment, exploration of new areas, and social growth and maturity.

All students (grades 9-12) are required to register for and complete a minimum of 60 hours of credit each year. Exception: (Students enrolled in vocal music may register for 56 hours of credit.) All seniors are required to successfully complete a minimum of 45 hours of credit in their fourth year of high school.

<u>Required Credit Hours</u>	<u>Credits</u>
ENGLISH - 40 CREDIT HOURS	
Grade 9 English 9	10
Grade 10 English 10	10
Grade 11 English 11 or 2 semesters of electives	10
Grade 12 English 12, Adv English, Applied English 12 or 2 semesters of electives	10
<u>Electives:</u> Western NE Lit, War Lit, Holocaust Lit, Creative Writing	
MATHEMATICS - 30 CREDIT HOURS	
Grade 9 Algebra A, Algebra I, Algebra II	10
Grade 10 Algebra B, Algebra I, Algebra II, Geometry, Applied Math	10
Grade 11-12 <u>Choices:</u> Algebra II, Geometry, Applied Math, Consumer Math,	10
Trig/Pre-Calculus, College Prep Math, College Alg, Calculus	
SCIENCE - 30 CREDIT HOURS	
Grade 9 Physical Science	10
Grade 10 General Biology	10
Grade 11 Chemistry I/II, Forensic Sci, Environmental Sci, Zoology, Marine Bio	10
Grade 12 <u>Choices:</u> Physics, Anatomy, Chemistry I/II, Adv Biology	10
SOCIAL STUDIES - 30 CREDIT HOURS	
Grade 9 World History	10
Grade 10 American History	10
Grade 11- 12 Government	10
BUSINESS - 10 CREDIT HOURS	
Grade 11 - 12 Economics/Personal Finance	10

<u>Required Credit Hours</u>	<u>Credits</u>
PHYSICAL EDUCATION - 10 CREDIT HOURS	
Grade 9 P.E/Health	10
COMPUTER TECHNOLOGY - 10 CREDIT HOURS	
Grade 9 Information Technology	5
Grade 9 Computer Science	5
SPEECH - 5 CREDIT HOURS	
Grade 10, 11, or 12 Speech	5

ALL OF THE ABOVE CLASSES MERIT FIVE (5) CREDIT HOURS PER SEMESTER

TOTAL REQUIRED CREDIT HOURS -	165
TOTAL ELECTIVE CREDIT HOURS -	<u>+75</u>
TOTAL CREDIT HOURS FOR GRADUATION -	240

COMMUNITY SERVICE REQUIREMENT - 60 HOURS (15 hours/school year)

Community Service Hours **MUST BE PRE-APPROVED** by the principal or guidance counselor. **In an effort to help students keep pace over their 4 years of high school, students will not be able to participate in the Homecoming dance, Winter Formal, Prom, or Class Competition Day Out of School if they have not met the following:**

- Freshmen (must have 5 hours completed & turned in by Prom/Day Out of School)
- Sophomores (must have 15 hours completed & turned in by Homecoming and 20 hours completed & turned in by Prom/Day Out of School)
- Juniors (must have 30 hours completed & turned in by Homecoming and 35 hours completed & turned in by Prom/Day Out of School)
- Seniors (must have 45 hours completed & turned in by Homecoming and 50 hours completed & turned in by Prom/Day Out of School)

DRIVERS EDUCATION

Students successfully completing driver education at Centennial will receive three (3) credit hours. Driver education grades do not count toward student grade point averages.

Graduation Requirement: Extracurricular Participation

Purpose

The Board of Education believes that participation in extracurricular activities enhances students' overall educational experience by fostering personal growth, leadership, and teamwork. The Board recognizes that these activities provide valuable opportunities for students to explore interests, develop talents, and build meaningful relationships with peers and mentors. Research indicates that students engaged in extracurricular programs often achieve higher academic success, develop strong time management skills, and feel a greater sense of belonging within their school community. Furthermore, involvement in athletics, fine arts, clubs, and other school-sponsored activities helps students build resilience, responsibility, and essential life skills that prepare them for success beyond high school.

Requirement

Effective beginning with the graduating class of 2027, all students must participate in at least one extracurricular activity during their high school years as a requirement for graduation.

Definition of Extracurricular Activity

An extracurricular activity is defined as any school-sponsored club, organization, athletic team, fine arts program, or academic competition.

Participation Criteria

- Students must actively participate in at least one extracurricular activity for a full season or designated period as determined by the sponsor or coach.
- Students who are unable to physically participate due to injury or health conditions may still fulfill this requirement if they remain a member of the team or group, attend practices, and contribute in a meaningful way as determined by the sponsor or coach.
- Transfer students who enroll after the start of high school must meet the participation requirement to the extent feasible during their time at Centennial Public School. Reasonable adjustments will be made based on the time of enrollment and prior participation at other accredited schools.
- All activities must be approved by the school administration.

Verification of Participation

- The school administration will maintain records of student participation.
- Students must submit a verification form, signed by the activity sponsor or coach, to their school counselor by May 1st of their junior year.

Exceptions and Waivers

- Exceptions may be granted in cases of extenuating circumstances, such as medical conditions, employment obligations, or other approved reasons.
- Requests for exemptions must be submitted in writing to the school principal for review and approval.

Implementation and Support

- School staff will provide students with information on available extracurricular opportunities.
- Accommodations will be made to ensure all students have access to participate, including students with disabilities, financial limitations, or other barriers to involvement.
- A designated staff member will be available to assist students in identifying and enrolling in suitable extracurricular activities.

McCormick's Heating & Air Conditioning

PO Box 217

York, NE 68467 USA

+14023624156

mccormickshvac@gmail.com



Proposal

ADDRESS
Centennial Public School Centennial Public School 1301 Centennial Ave Utica, NE 68456

PROPOSAL #	DATE
1211	04/25/2025

ACTIVITY	QTY	RATE	AMOUNT
Services		35,210.44	35,210.44
Residential Hoods			
Commercial Oven Hood			
Hangars & Supports			
Residential Hod 8" Exhaust to Roof Curb			
Re-Work of Commercial Head Exhaust Duct			
Start-up Checkout			
Stainless Steel Wrapper Install			
Labor			
*No High Voltage Electrical			
*No Roof Work. New Penetration's sealed & Waterproofed by Other's.			
* No Ceiling Work. All Ceiling Grid & Pad Work by Others.			
* No Tax Included			

SUBTOTAL	35,210.44
TAX	0.00
TOTAL	\$35,210.44

Accepted By

Accepted Date

FOR QUESTIONS, CALL THE
Nebraska Mechanical
REGION 117
PHONE: (402) 817 - 1779
EMAIL: reg117@econair.com

HOOD INFORMATION - JOB#7488143

HOOD NO	TAG	MODEL	MANUFACTURER	LENGTH	MAX COOKING TEMP	TYPE	APPLIANCE DUTY	DESIGN CFM/FT	TOTAL EXH CFM	EXHAUST PLENUM RISER(S)				HOOD CONSTRUCTION	HOOD CONFIG		SWITCHES				
										WIDTH	LENG	HEIGHT	DIA		CFM	VEL	SP	END TO END	ROW	QUANTITY	LOCATION
1	KH-1	3044 BD-2	CAPTIVEAIRE	2' 6"	450 DEG	I	MEDIUM	150	375			4"	8"	375	1074	-0.222'	430 SS WHERE EXPOSED	ALONE	ALONE	1 FAN	FRONT RIGHT FACE
2	KH-2	3044 BD-2	CAPTIVEAIRE	2' 6"	450 DEG	I	MEDIUM	150	375			4"	8"	375	1074	-0.222'	430 SS WHERE EXPOSED	ALONE	ALONE	1 FAN	FRONT RIGHT FACE
3	KH-3	3044 BD-2	CAPTIVEAIRE	2' 6"	450 DEG	I	MEDIUM	150	375			4"	8"	375	1074	-0.222'	430 SS WHERE EXPOSED	ALONE	ALONE	1 FAN	FRONT RIGHT FACE
4	KH-4	3044 BD-2	CAPTIVEAIRE	2' 6"	450 DEG	I	MEDIUM	150	375			4"	8"	375	1074	-0.222'	430 SS WHERE EXPOSED	ALONE	ALONE	1 FAN	FRONT RIGHT FACE
5	KH-5	3044 BD-2	CAPTIVEAIRE	5' 6"	600 DEG	I	HEAVY	150	825			4"	10"	825	1513	-0.568'	430 SS WHERE EXPOSED	ALONE	ALONE	1 FAN	FRONT RIGHT FACE

HOOD INFORMATION

HOOD NO	TAG	FILTER(S)				LIGHT(S)				UTILITY CABINET(S)				FIRE SYSTEM PIPING	HOOD HANGING WEIGHT				
		TYPE	QTY	HEIGHT	LENGTH	EFFICIENCY @ 7 MICRONS	QTY	TYPE	WIRE GUARD	LOCATION	SIZE	FIRE SYSTEM	SIZE			ELECTRICAL	MODEL #	SWITCHES	QUANTITY
1	KH-1	CAPTRATE SOLID FILTER	1	16"	20"	85% SEE FILTER SPEC	1	RECESSED ROUND	NO									NO	154 LBS
2	KH-2	CAPTRATE SOLID FILTER	1	16"	20"	85% SEE FILTER SPEC	1	RECESSED ROUND	NO									NO	154 LBS
3	KH-3	CAPTRATE SOLID FILTER	1	16"	20"	85% SEE FILTER SPEC	1	RECESSED ROUND	NO									NO	154 LBS
4	KH-4	CAPTRATE SOLID FILTER	1	16"	20"	85% SEE FILTER SPEC	1	RECESSED ROUND	NO									NO	154 LBS
5	KH-5	CAPTRATE SOLID FILTER	4	16"	16"	85% SEE FILTER SPEC	2	RECESSED ROUND	NO									NO	246 LBS

HOOD OPTIONS

HOOD NO	TAG	OPTION
1	KH-1	FIELD WRAPPER 37.00" HIGH FRONT, LEFT, RIGHT. RIGHT QUARTER END PANEL 20" TOP WIDTH, 0" BOTTOM WIDTH, 20" HIGH 430 SS. LEFT QUARTER END PANEL 20" TOP WIDTH, 0" BOTTOM WIDTH, 20" HIGH 430 SS.
2	KH-2	FIELD WRAPPER 37.00" HIGH FRONT, LEFT, RIGHT. RIGHT QUARTER END PANEL 20" TOP WIDTH, 0" BOTTOM WIDTH, 20" HIGH 430 SS. LEFT QUARTER END PANEL 20" TOP WIDTH, 0" BOTTOM WIDTH, 20" HIGH 430 SS.
3	KH-3	FIELD WRAPPER 37.00" HIGH FRONT, LEFT, RIGHT. RIGHT QUARTER END PANEL 20" TOP WIDTH, 0" BOTTOM WIDTH, 20" HIGH 430 SS. LEFT QUARTER END PANEL 20" TOP WIDTH, 0" BOTTOM WIDTH, 20" HIGH 430 SS.
4	KH-4	FIELD WRAPPER 37.00" HIGH FRONT, LEFT, RIGHT. RIGHT QUARTER END PANEL 20" TOP WIDTH, 0" BOTTOM WIDTH, 20" HIGH 430 SS. LEFT QUARTER END PANEL 20" TOP WIDTH, 0" BOTTOM WIDTH, 20" HIGH 430 SS.
5	KH-5	FIELD WRAPPER 37.00" HIGH FRONT, LEFT, RIGHT. RIGHT QUARTER END PANEL 20" TOP WIDTH, 0" BOTTOM WIDTH, 20" HIGH 430 SS. LEFT QUARTER END PANEL 20" TOP WIDTH, 0" BOTTOM WIDTH, 20" HIGH 430 SS.

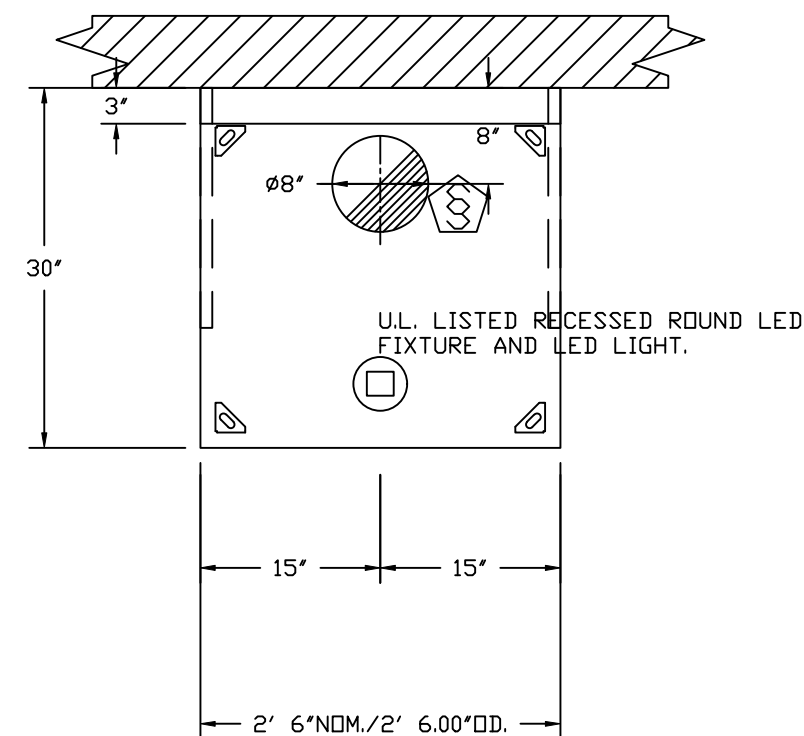

PLAN VIEW - HOOD #1 (KH-1), #2 (KH-2), #3 (KH-3), #4 (KH-4)
2' 6.00" LONG 3044BD-2

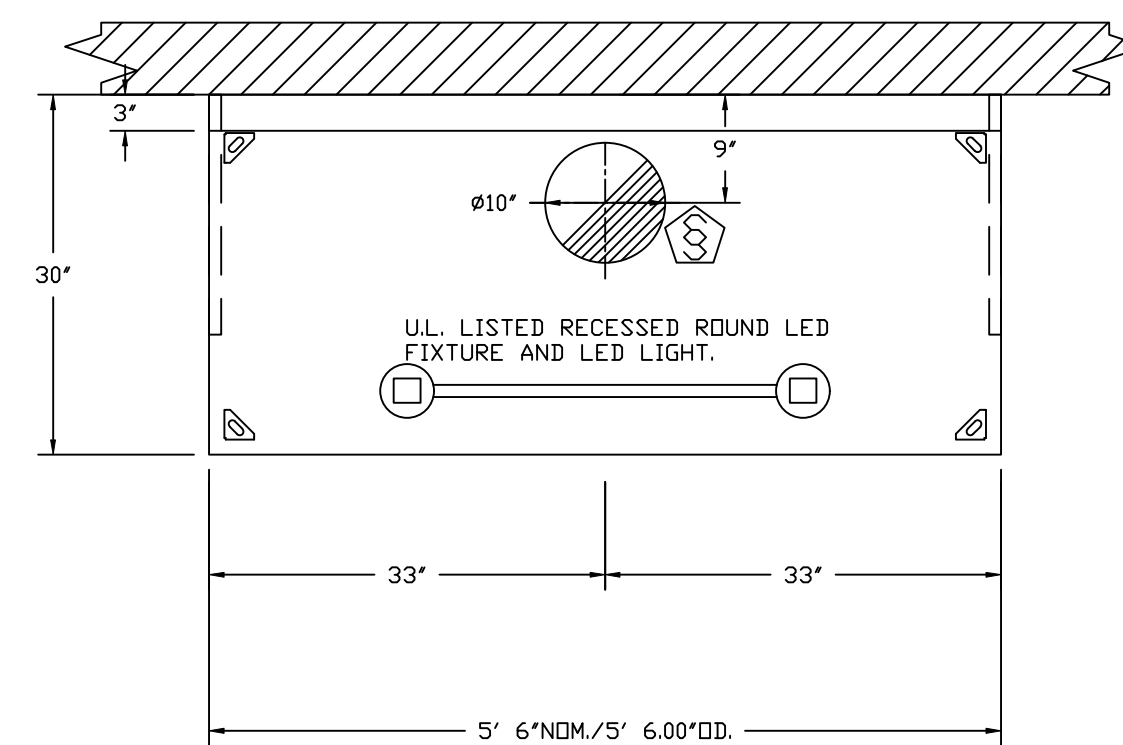

PLAN VIEW - HOOD #5 (KH-5)
5' 6.00" LONG 3044BD-2

GREASE DUCT & CHIMNEY SPECIFICATIONS:
PROVIDE GREASE DUCT EQUAL TO ECON-AIR MODEL "EDW" ROUND 20 GAUGE 430 STAINLESS STEEL DUCTWORK. MODEL "EDW" IS LISTED TO UL-1978 AND IS INSTALLED USING "V" CLAMP LOCKING CONNECTIONS SEALED WITH 3M FIRE BARRIER 2000 PLUS. MODEL "EDW" DOES NOT REQUIRE WELDING PROVIDING IT HAS BEEN INSTALLED PER THE MANUFACTURES INSTALLATION GUIDE. PROVIDE RATED ACCESS DOORS AT EVERY CHANGE IN DIRECTION AND EVERY 12' ON CENTER. PER MANUFACTURES LISTING MODEL "EDW" HORIZONTAL RUNS LESS THAN 75 FT. CAN BE SLOPED 1/16" PER 12", HORIZONTAL RUNS MORE THAN 75 FT. CAN BE SLOPED 3/16" PER 12". DUCT SHOULD BE SLOPED AS MUCH AS POSSIBLE TO REDUCE THE CHANCE OF GREASE ACCUMULATION IN HORIZONTAL RUNS.

IF THE DUCT OR CHIMNEY IS WITHIN 18 INCHES OF COMBUSTIBLE MATERIAL, PROVIDE UL-2221 OR UL-103 HT LISTED DOUBLE WALL GREASE DUCT OR DOUBLE WALL CHIMNEY EQUAL TO ECON-AIR MODEL "EDW- 2R, 2R TYPE HT, 3R, OR 3Z" ROUND 20 GAUGE 430 STAINLESS INNER DUCT INSULATED WITH A 24 GAUGE 430 STAINLESS OUTER SHELL.

ECON-AIR RECOMMENDS THE USE OF LISTED, PRE-FABRICATED ROUND GREASE EXHAUST DUCT TO REDUCE STATIC PRESSURE IN THE SYSTEM, MINIMIZE INSTALLATION AND INSPECTION TIMES, AND ENSURE DUCT IS LIQUID TIGHT

VERIFY CEILING HEIGHT
____' - ____"
HEIGHT REQUIRED TO VERIFY THAT HOOD FITS SPACE AND TO SIZE THE ENCLOSURE PANELS

HVAC DISTRIBUTION NOTE
HIGH VELOCITY DIFFUSERS OR HVAC RETURNS SHOULD NOT BE PLACED WITHIN TEN (10) FEET OF THE EXHAUST HOOD. PERFORATED DIFFUSERS ARE RECOMMENDED.

CUSTOMER APPROVAL TO MANUFACTURE:

APPROVED AS NOTED

APPROVED WITH NO EXCEPTION TAKEN

REVISE AND RESUBMIT

SIGNATURE _____

YOUR TITLE _____ DATE _____

SPECIFICATION: CAPTRATE® GREASE-STOP® SOLID FILTER

THE CAPTRATE GREASE-STOP SOLID FILTER IS A SINGLE-STAGE FILTER FEATURING A UNIQUE S-BAFFLE DESIGN IN CONJUNCTION WITH A SLOTTED REAR BAFFLE DESIGN, TO DELIVER EXCEPTIONAL FILTRATION EFFICIENCY.

FILTER IS STAINLESS STEEL CONSTRUCTION, AND SIZED TO FIT INTO STANDARD 2-INCH DEEP HOOD CHANNEL(S).

UNITS SHALL INCLUDE STAINLESS STEEL HANDLES AND A FASTENING DEVICE TO SECURE THE TWO COMPONENTS WHEN ASSEMBLED.

GREASE EXTRACTION EFFICIENCY PERFORMANCE SHALL REMOVE AT LEAST 75% OF GREASE PARTICLES FIVE MICRONS IN SIZE, AND 85% GREASE PARTICLES SEVEN MICRONS IN SIZE AND LARGER, WITH A CORRESPONDING PRESSURE DROP NOT TO EXCEED 1.0 INCHES OF WATER GAUGE. THE CAPTRATE GREASE-STOP SOLID WAS TESTED TO ASTM STANDARD ASTM F2519-05. MANUFACTURER APPROVED FOR USE IN SOLID FUEL APPLICATIONS AS A SPARK ARRESTER.

EFFICIENCY VS. PARTICLE DIAMETER

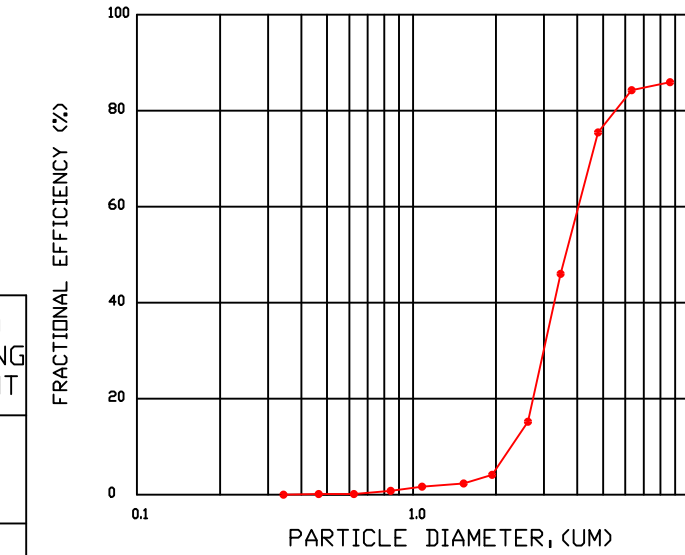

PRESSURE DROP VS. FLOW RATE

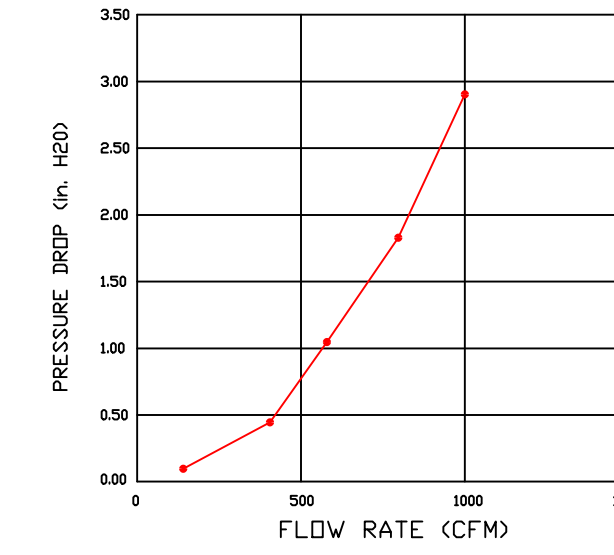

CAPTRATE FILTERS ARE BUILT IN COMPLIANCE WITH:

- NFPA #96.
- NSF STANDARD #2.
- UL STANDARD #1046.
- INT. MECH. CODE (IMC).
- ULC-S649.



REVISIONS

NO.	DESCRIPTION	DATE

Nebraska Mechanical
www.econair.com

4611 S 96th St, Suite 281, Omaha, NE 68127 PHONE: (402) 817 - 1779 EMAIL: reg117@econair.com

Centennial Public School - Utica, NE_R3
UTICA, NE, 68456

DATE: 4/23/2025
DWG.#: 7488143
DRAWN BY: austinlowell
SCALE: 3/4" = 1'-0"
MASTER DRAWING

SHEET NO.
1

EXHAUST FAN INFORMATION – JOB#7488143

FAN UNIT NO	TAG	QTY	FAN UNIT MODEL #	MANUFACTURER	CFM	ESP	RPM	MOTOR ENCL	HP	BHP	PHASE	VOLT	FLA	DISCHARGE VELOCITY	WEIGHT (LBS)	SDNES
1	KEF-1	1	DUI2HFA	CAPTIVEAIRE	375	0.350	1431	TEAD-ECM	0.250	0.0750	1	115	2.9	266 FPM	60	7.7
2	KEF-2	1	DUI2HFA	CAPTIVEAIRE	375	0.350	1431	TEAD-ECM	0.250	0.0750	1	115	2.9	266 FPM	60	7.7
3	KEF-3	1	DUI2HFA	CAPTIVEAIRE	375	0.350	1431	TEAD-ECM	0.250	0.0750	1	115	2.9	266 FPM	60	7.7
4	KEF-4	1	DUI2HFA	CAPTIVEAIRE	375	0.350	1431	TEAD-ECM	0.250	0.0750	1	115	2.9	266 FPM	60	7.7

FAN OPTIONS

FAN UNIT NO	TAG	QTY	DESCRIPTION
1	KEF-1	1	GREASE BOX
		1	FAN BASE CERAMIC SEAL – DU/DR12HFA – INSTALLED AT PLANT – FOR GREASE DUCTS
		1	ECM WIRING PACKAGE – EXHAUST – MANUAL DR 0-10VDC REFERENCE SPEED CONTROL –MSC- (TELCD), CCW ROTATION
		1	2 YEAR PARTS WARRANTY
2	KEF-2	1	GREASE BOX
		1	FAN BASE CERAMIC SEAL – DU/DR12HFA – INSTALLED AT PLANT – FOR GREASE DUCTS
		1	ECM WIRING PACKAGE – EXHAUST – MANUAL DR 0-10VDC REFERENCE SPEED CONTROL –MSC- (TELCD), CCW ROTATION
		1	2 YEAR PARTS WARRANTY
3	KEF-3	1	GREASE BOX
		1	FAN BASE CERAMIC SEAL – DU/DR12HFA – INSTALLED AT PLANT – FOR GREASE DUCTS
		1	ECM WIRING PACKAGE – EXHAUST – MANUAL DR 0-10VDC REFERENCE SPEED CONTROL –MSC- (TELCD), CCW ROTATION
		1	2 YEAR PARTS WARRANTY
4	KEF-4	1	GREASE BOX
		1	FAN BASE CERAMIC SEAL – DU/DR12HFA – INSTALLED AT PLANT – FOR GREASE DUCTS
		1	ECM WIRING PACKAGE – EXHAUST – MANUAL DR 0-10VDC REFERENCE SPEED CONTROL –MSC- (TELCD), CCW ROTATION
		1	2 YEAR PARTS WARRANTY

FAN ACCESSORIES

FAN UNIT NO	TAG	EXHAUST				SUPPLY			
		GREASE CUP	GRAVITY DAMPER	WALL MOUNT	SIDE DISCHARGE	GRAVITY DAMPER	MOTORIZED DAMPER	WALL MOUNT	
1	KEF-1	YES							
2	KEF-2	YES							
3	KEF-3	YES							
4	KEF-4	YES							

CURB ASSEMBLIES

NO	ON FAN	TAG	WEIGHT	ITEM	SIZE
1	# 1	KEF-1	35 LBS	CURB	17.500"W X 17.500"L X 24.000"H INSULATED VENTED HINGED.
2	# 2	KEF-2	35 LBS	CURB	17.500"W X 17.500"L X 24.000"H INSULATED VENTED HINGED.
3	# 3	KEF-3	35 LBS	CURB	17.500"W X 17.500"L X 24.000"H INSULATED VENTED HINGED.
4	# 4	KEF-4	35 LBS	CURB	17.500"W X 17.500"L X 24.000"H INSULATED VENTED HINGED.

FANS #1 (KEF-1), #2 (KEF-2), #3 (KEF-3), #4 (KEF-4) – DUI2HFA EXHAUST FAN

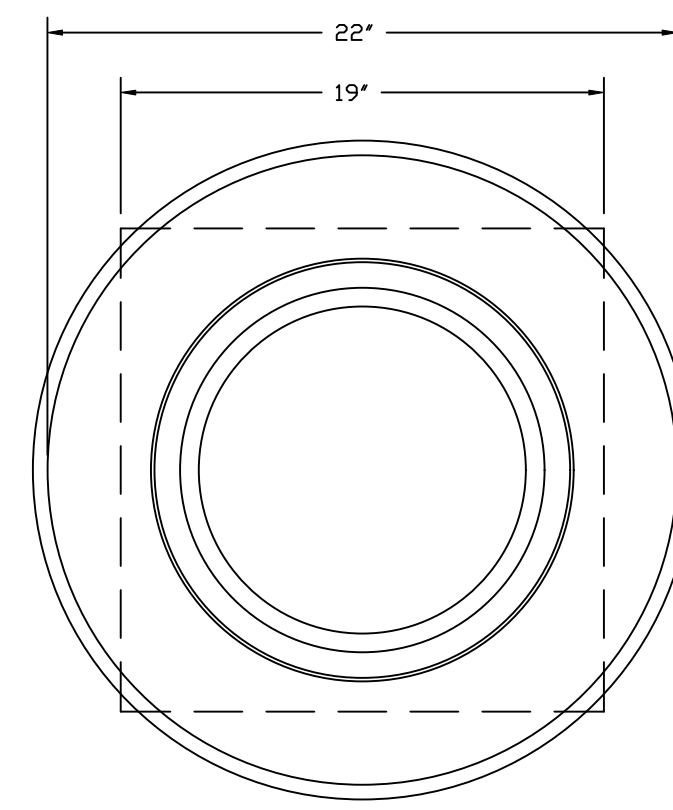
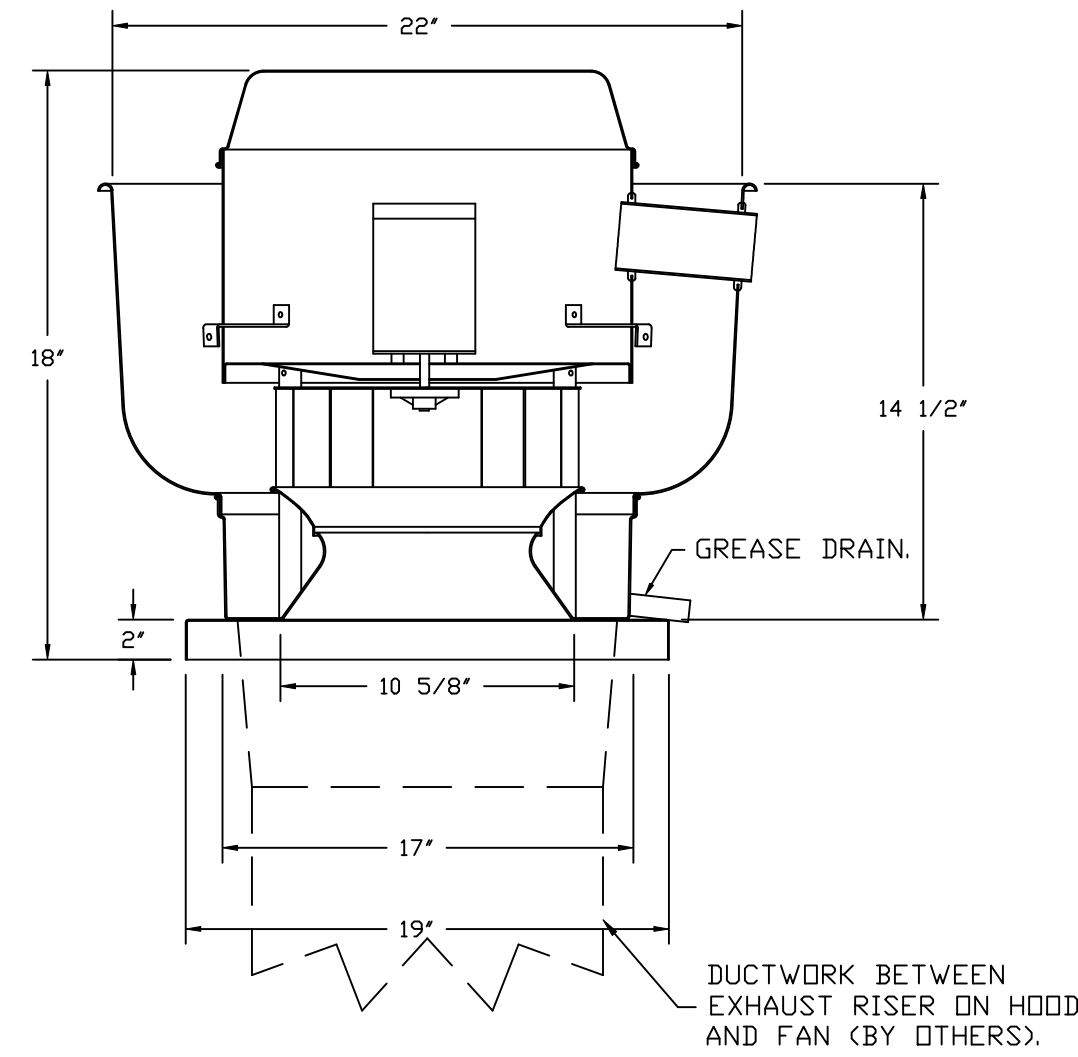

TOP VIEW

FEATURES:

- DIRECT DRIVE CONSTRUCTION (NO BELTS/PULLEYS).
- ROOF MOUNTED FANS.
- RESTAURANT MODEL.
- UL705 AND UL762 AND ULC-S645
- VARIABLE SPEED CONTROL.
- INTERNAL WIRING.
- THERMAL OVERLOAD PROTECTION (SINGLE PHASE).
- HIGH HEAT OPERATION 300°F (149°C).
- GREASE CLASSIFICATION TESTING.
- NEMA 3R SAFETY DISCONNECT SWITCH.

NORMAL TEMPERATURE TEST

EXHAUST FAN MUST OPERATE CONTINUOUSLY WHILE EXHAUSTING AIR AT 300°F (149°C) UNTIL ALL FAN PARTS HAVE REACHED THERMAL EQUILIBRIUM, AND WITHOUT ANY DETERIORATING EFFECTS TO THE FAN WHICH WOULD CAUSE UNSAFE OPERATION.

ABNORMAL FLARE-UP TEST

EXHAUST FAN MUST OPERATE CONTINUOUSLY WHILE EXHAUSTING BURNING GREASE VAPORS AT 600°F (316°C) FOR A PERIOD OF 15 MINUTES WITHOUT THE FAN BECOMING DAMAGED TO ANY EXTENT THAT COULD CAUSE AN UNSAFE CONDITION.

OPTIONS

- GREASE BOX.
- FAN BASE CERAMIC SEAL – DU/DR12HFA – INSTALLED AT PLANT – FOR GREASE DUCTS.
- ECM WIRING PACKAGE – EXHAUST – MANUAL DR 0-10VDC REFERENCE SPEED CONTROL –MSC- (TELCD), CCW ROTATION.
- 2 YEAR PARTS WARRANTY.

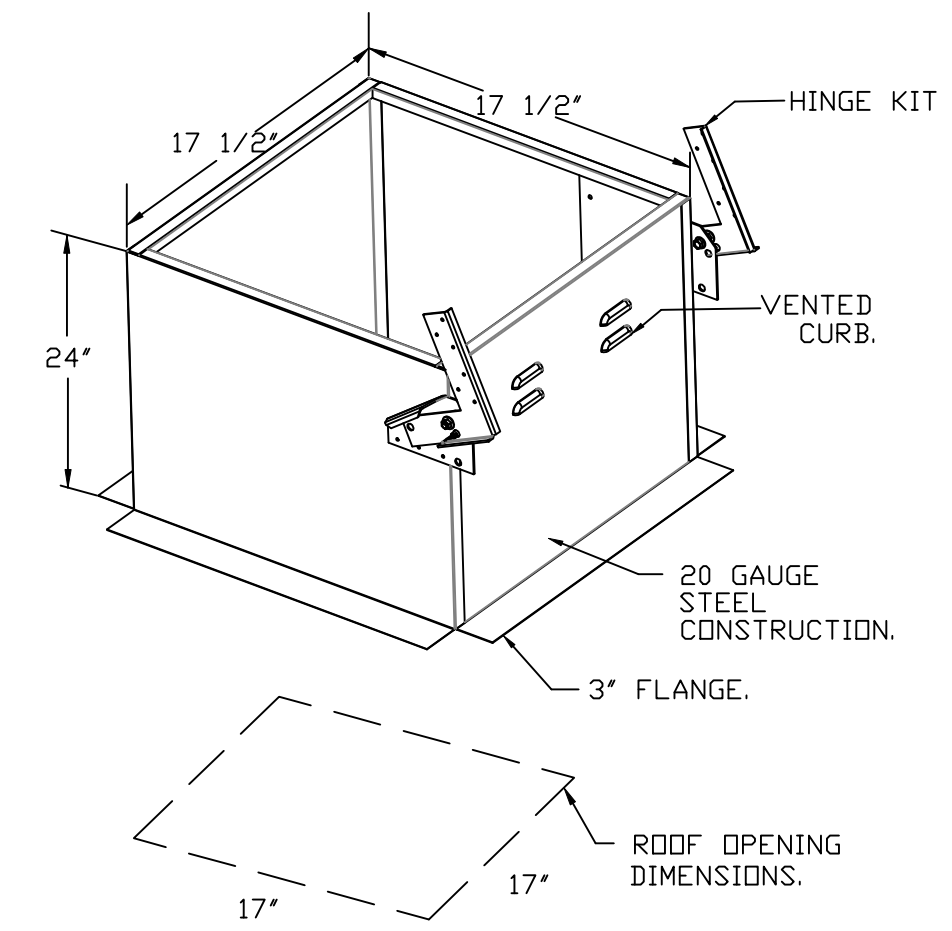

REVISIONS

NO.	DESCRIPTION	DATE

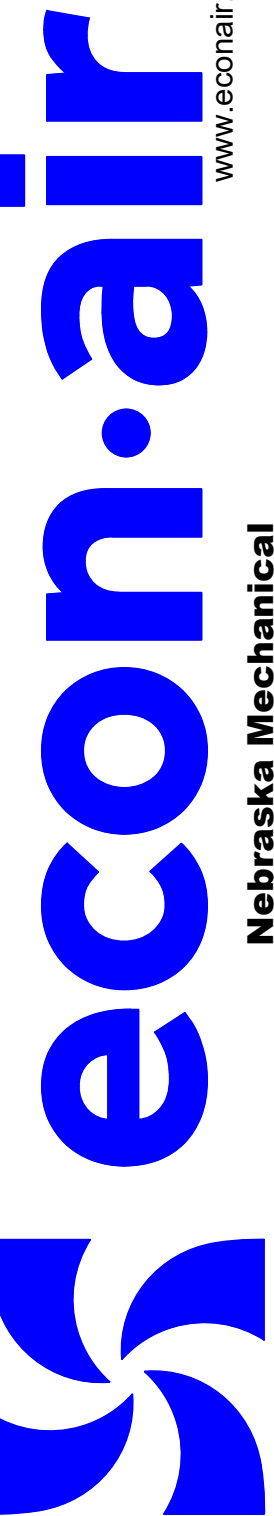
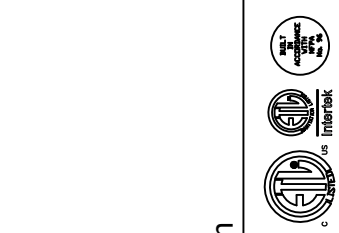

Centennial Public School - Utica, NE_R3
UTICA, NE, 68456

DATE: 4/23/2025

DWG.#:
7488143

DRAWN BY: austinlowell

SCALE:
3/4" = 1'-0"

MASTER DRAWING

SHEET NO.
3

8 GREASE DUCT & CHIMNEY SPECIFICATIONS:
 PROVIDE GREASE DUCT EQUAL TO ECON-AIR MODEL "EDW"
 ROUND 20 GAUGE 430 STAINLESS STEEL DUCTWORK. MODEL "EDW"
 IS LISTED TO UL-1978 AND IS INSTALLED USING "V" CLAMP LOCKING
 CONNECTIONS SEALED WITH 3M FIRE BARRIER 2000 PLUS. MODEL "EDW"
 DOES NOT REQUIRE WELDING PROVIDING IT HAS BEEN INSTALLED PER
 THE MANUFACTURES INSTALLATION GUIDE.
 PROVIDE RATED ACCESS DOORS AT EVERY CHANGE IN DIRECTION AND EVERY 12' ON CENTER.
 PER MANUFACTURES LISTING MODEL "EDW" HORIZONTAL RUNS LESS THAN 75 FT. CAN BE
 SLOPED 1/16" PER 12", HORIZONTAL RUNS MORE THAN 75 FT. CAN BE SLOPED 3/16" PER 12".
 DUCT SHOULD BE SLOPED AS MUCH AS POSSIBLE TO REDUCE THE CHANCE OF GREASE
 ACCUMULATION IN HORIZONTAL RUNS.

IF THE DUCT OR CHIMNEY IS WITHIN 18 INCHES OF COMBUSTIBLE MATERIAL, PROVIDE
 UL-2221 OR UL-103 HT LISTED DOUBLE WALL GREASE DUCT OR DOUBLE WALL CHIMNEY
 EQUAL TO ECON-AIR MODEL "EDW- 2R, 2R TYPE HT, 3R, OR 3Z" ROUND 20 GAUGE 430
 STAINLESS INNER DUCT INSULATED WITH A 24 GAUGE 430 STAINLESS OUTER SHELL.

CUSTOMER APPROVAL TO MANUFACTURE:

APPROVED AS NOTED	<input type="checkbox"/>
APPROVED WITH NO EXCEPTION TAKEN	<input type="checkbox"/>
REVISE AND RESUBMIT	<input type="checkbox"/>
SIGNATURE _____	_____
YOUR TITLE _____	DATE _____

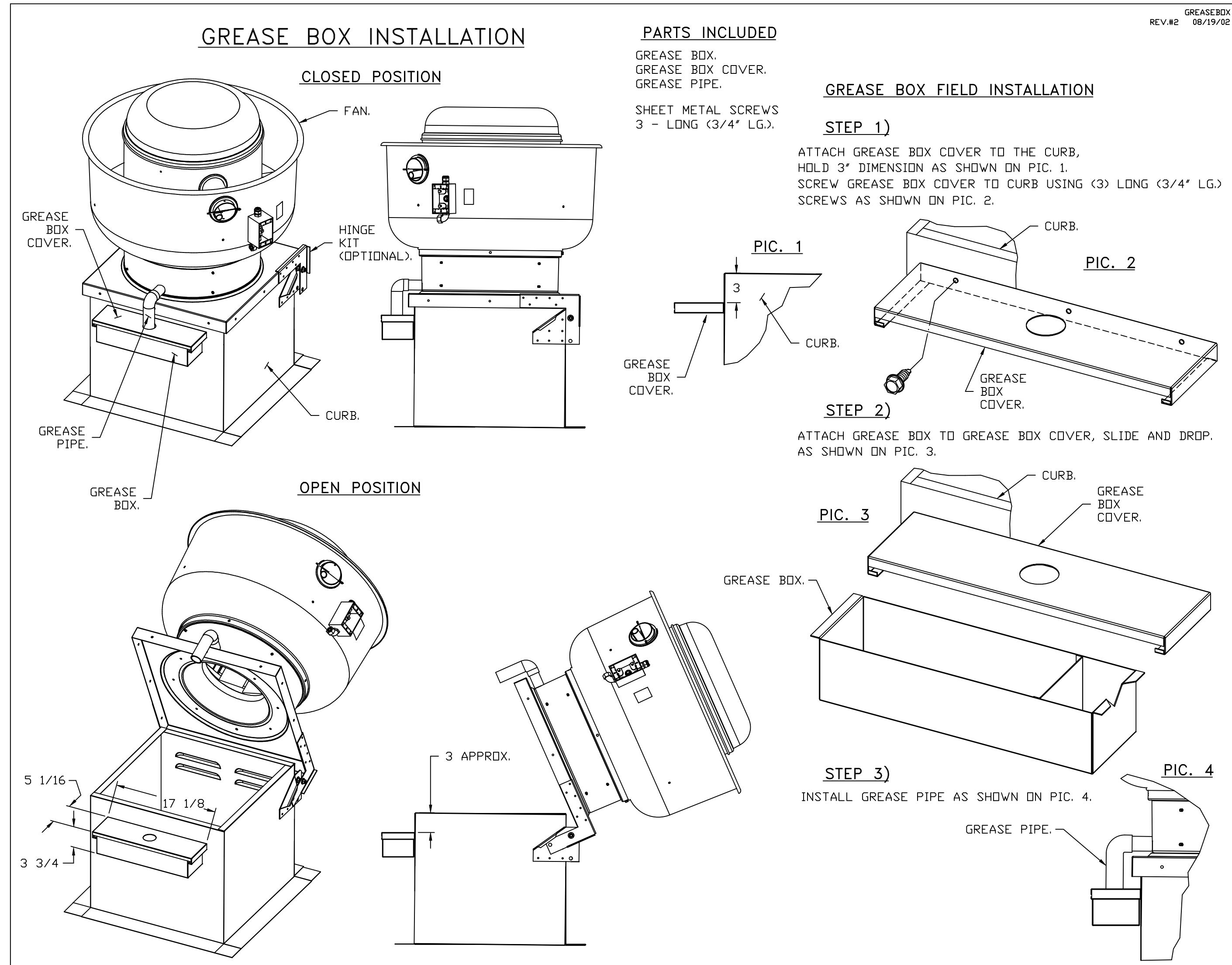

*NOTE: UL 705 INSTALL.

REVISIONS

REVISIONS	DESCRIPTION	DATE:
Δ		
Δ		
Δ		
Δ		

econ·air
 www.econair.com

Nebraska Mechanical
 4611 S 96th St, Suite 281, Omaha, NE, 68127 PHONE: (402) 817 - 1779 EMAIL: reg117@econair.com

Centennial Public School - Utica, NE_R3
 UTICA, NE, 68456

DATE: 4/23/2025

DWG.#:
 7488143

DRAWN BY: austinlowell

SCALE:
 3/4" = 1'-0"

MASTER DRAWING

SHEET NO.
 4

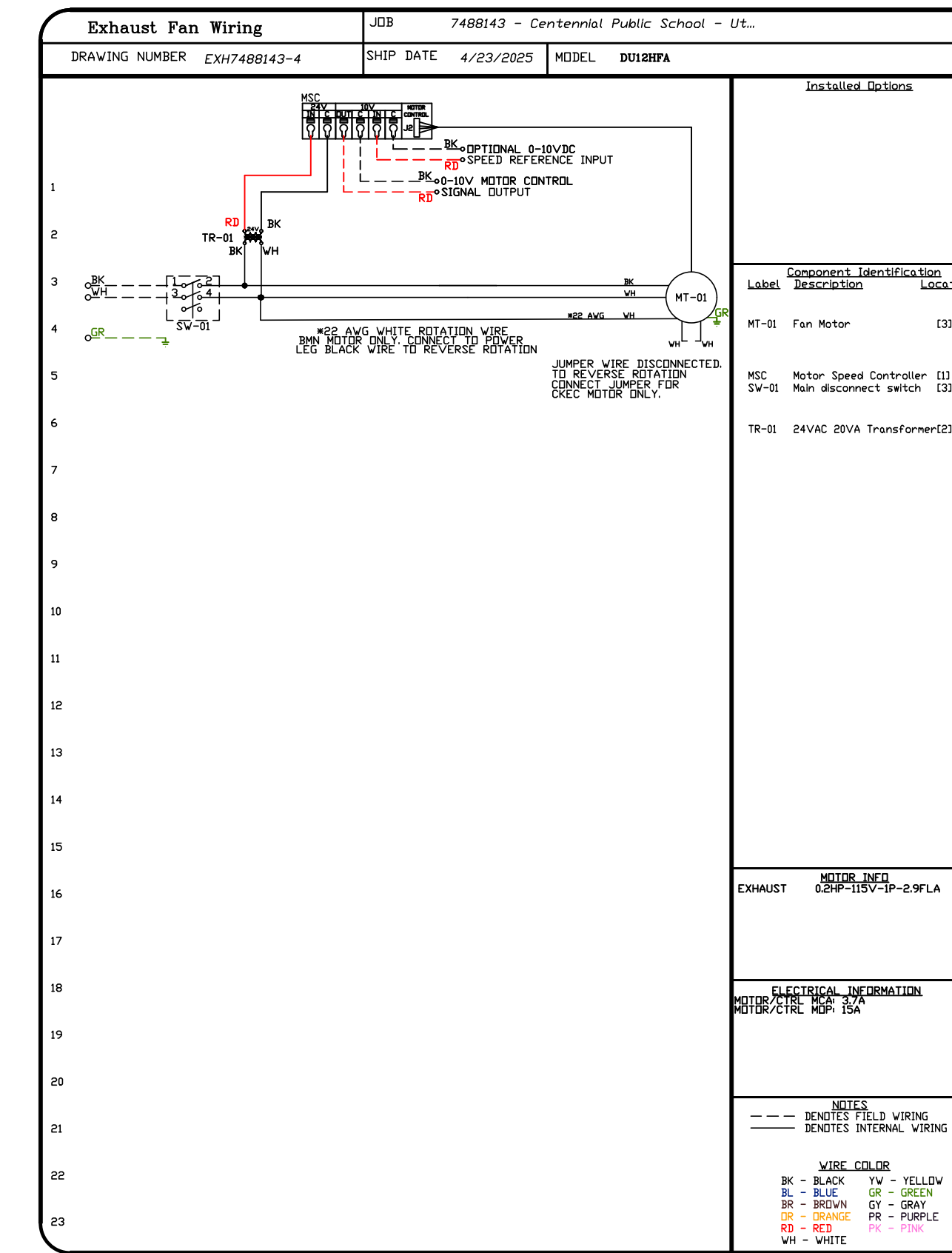
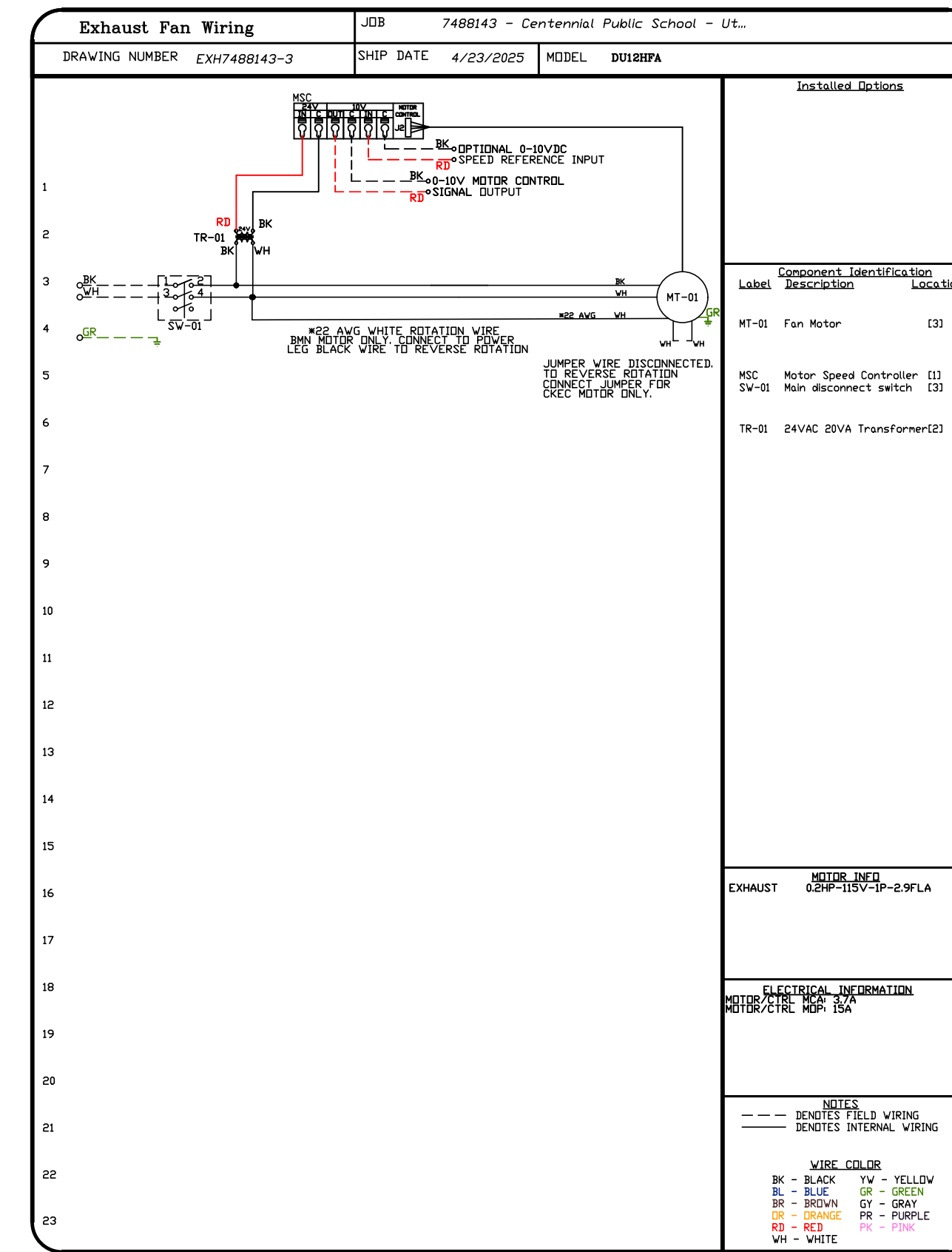
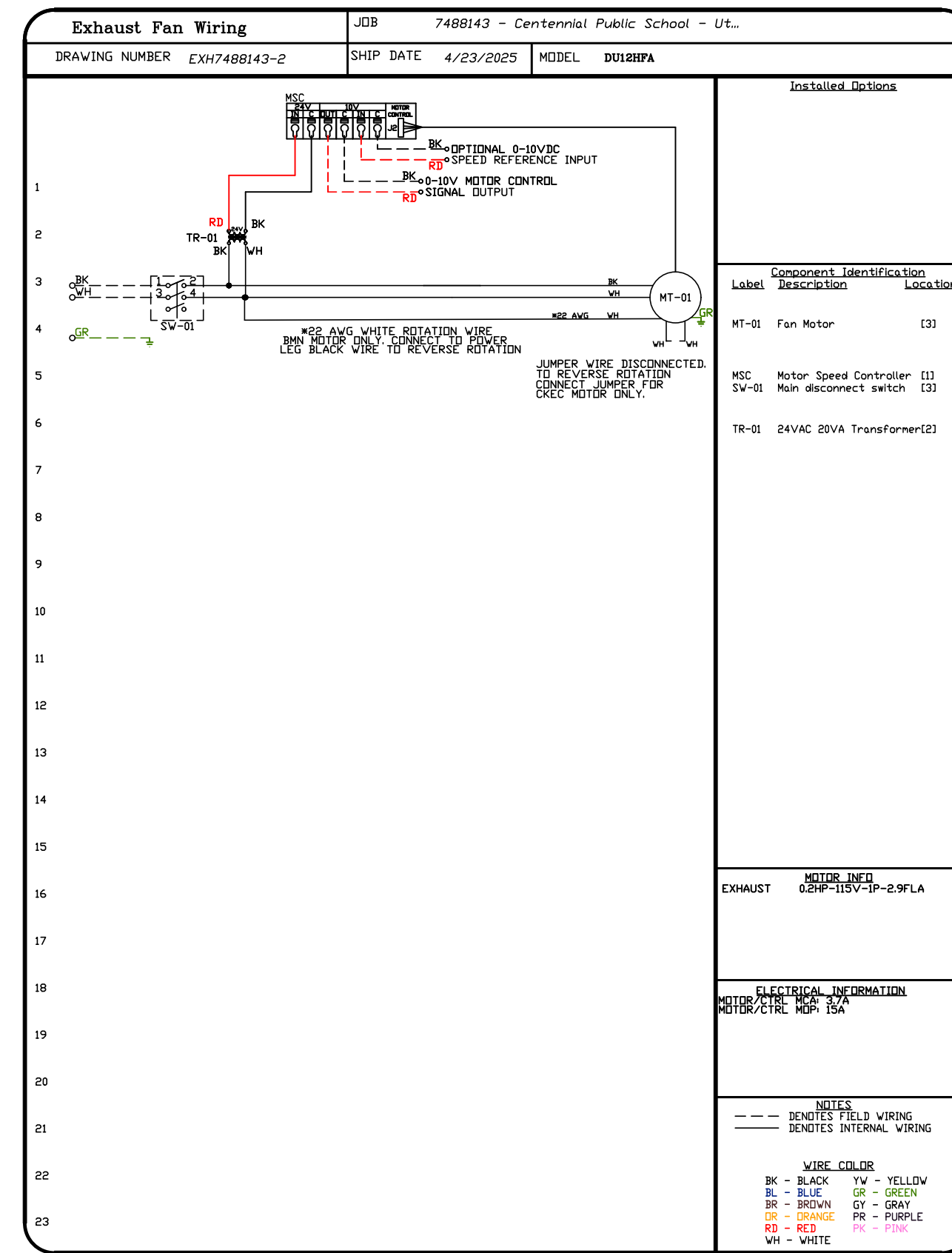
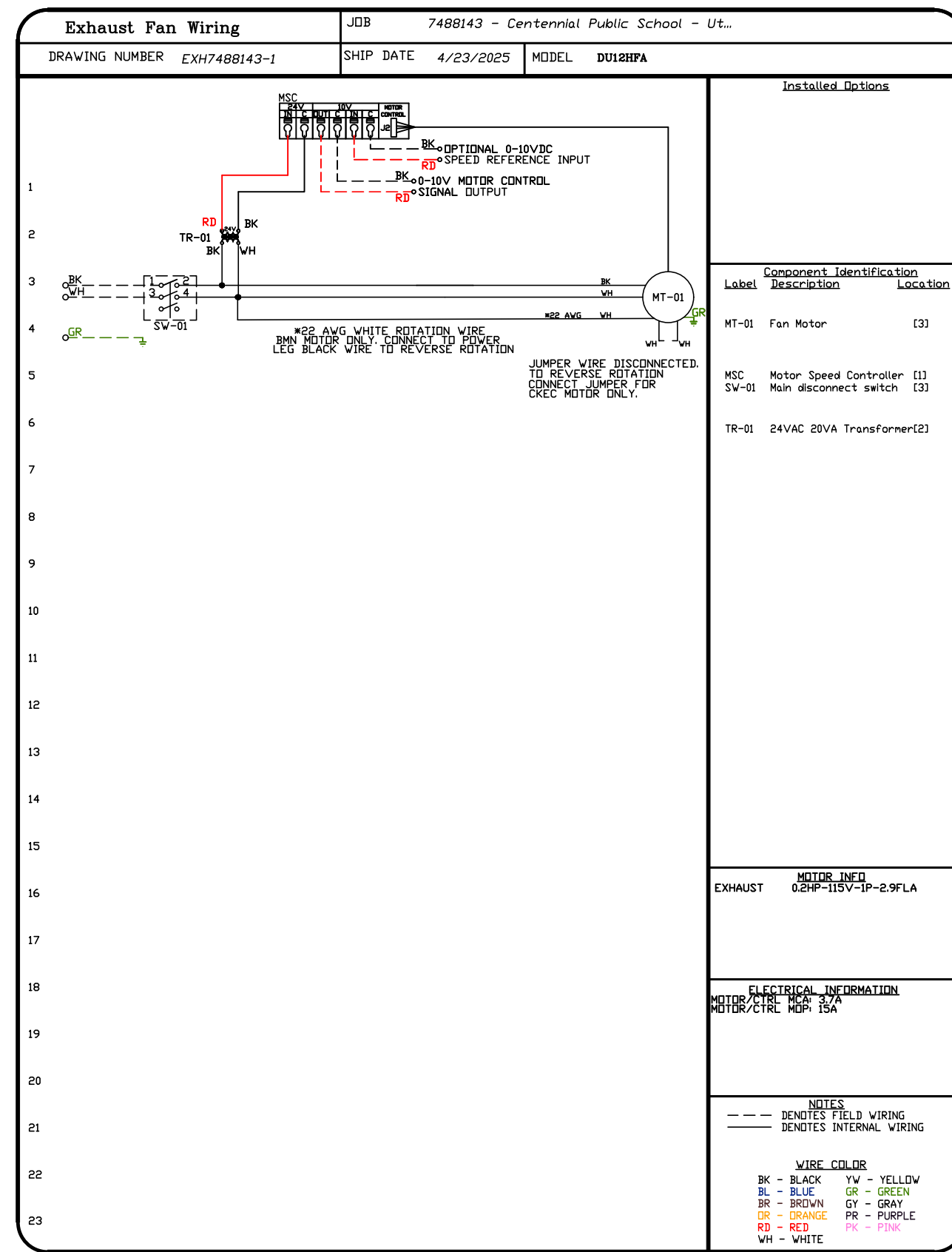

REVISIONS

DESCRIPTION	DATE:

Nebraska Mechanical
 www.econair.com
 4811 S 96th St, Suite 281, Omaha, NE 68127 PHONE: (402) 817-1779 EMAIL: reg117@econair.com

Centennial Public School - Utica, NE_R3
 UTICA, NE, 68456

DATE: 4/23/2025
DWG.#: 7488143
DRAWN BY: austinlowell
SCALE: 3/4" = 1'-0"
MASTER DRAWING

SHEET NO.
 5

ESTD



1976

120 S. 4TH ST.
Seward, NE 68434
Phone: 402-643-4434

PROPOSAL SUBMITTED TO		PHONE	DATE
Centennial Public School		(402) 641-0725 Dan Tesar (402) 534-2321 x236	4/1/2025 Revised 4/29/25
STREET		JOB NAME	
1301 Centennial Avenue		Hoods for FCS classroom	
CITY, STATE and ZIP CODE		JOB LOCATION	
Utica, NE 68456		Same	
ARCHITECT	DATE OF PLANS		JOB PHONE
		dan.tesar@centennialbroncos.org	

Furnish and Install: Bid per owner's specifications and drawings.

Base Bid: Captive-Aire hoods, #1- 3044BD2 (2'6" long), #2- 3044BD2 (2'6" long), #3- 3044BD-2 (2'6" long), #4- 3044BD-2 (2'6" long), #5 3034 BD2-5' 6", Four exhaust fans model DU12HAF, fan curbs, revised venting as needed, start and check.

Factory Warranty on equipment. All wiring and roof repair by owner. **See attached specification sheets for complete product details. This bid is for 5 hoods & 4 fans. Lead time is approx. 2 weeks.

\$47,150.00

****Material and labor: Redo 2" gas lines per existing design. Pro-press pipe, fittings & custom S.S. wall cover for gas line. \$8,810.00**

Project Includes: 1 year warranty on workmanship.

We Propose hereby to furnish material and labor-complete in accordance with above specifications, for the sum of: see above.

Payment to be made as follows:

55% down and balance upon Completion

All Material is Guaranteed to be as specified. All work to be completed in a workman like manner according to standard practices. Any alteration or deviation from the above specifications involving extra costs will be executed only upon written orders and will become an extra charge over the above estimate. All agreements contingent upon strikes, accidents or delays beyond our control. Owner to carry fire, tornado and other necessary insurance. Our workers are fully covered by Workman's Compensation Insurance.

Authorized: Brian Krohe

Signature

: This proposal may be.

withdrawn by us if not accepted in 15 days

Acceptance of Proposal

The above prices specifications and conditions are satisfactory and are hereby accepted. You are authorized to do the work as specified. Payment will be made as out lined above.

Signature:

Date of Acceptance:

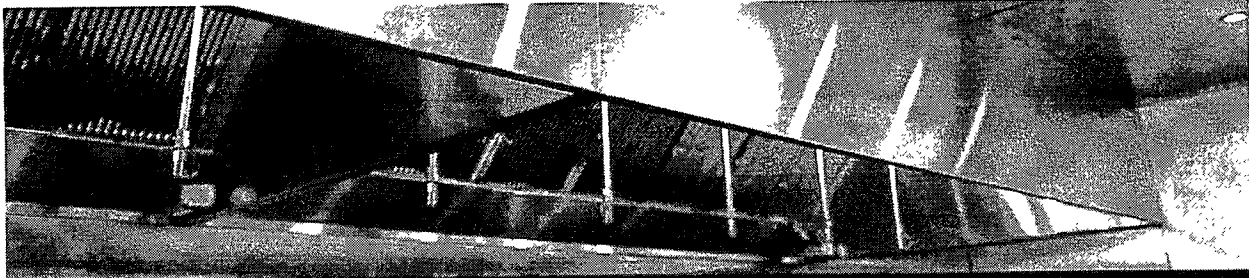

QUOTE

Tuesday, April 29, 2025

Quote# 7499687 - Centennial Public School - Utica, NE_R3

To:
 Bob Lockwood
 H&S Plumbing Heating & Air
 120 South 4th Street
 Seward, NE 68434-2108
 Phone: (402) 643 - 4434
estimating@sewardplumbingvac.com

From:
 Austin Lowell
 Econ-Air
 4611 S 96th St
 Suite 281
 Omaha, NE 68127
 Phone: (402) 817 - 1779
reg117@econair.com

Ship To:
 UTICA, NE 68456

Econ-Air proposes to furnish the following equipment. Production of listed items will commence upon receipt of an approved proposal, a purchase order, an approved submittal and approved credit.

EQUIPMENT:

Hood #1 - KH-1 - Job #7499687

- 3044BD-2 - 2ft 6" Long Low Proximity Sloped Backshelf Hood and a Built-In 3" Back Standoff. 14 inch Tall Front. x1

- 430 SS Where Exposed x1
- FILTER - 16" tall x 20" (15.625" by 19.625") wide Stainless Steel Captrate Solo filter with hook, ETL Listed. Particulate capture efficiency: 85% efficient at 9 microns, 76% efficient at 5 microns. Used on hoods shipped AFTER 7/27/17. x1
- Recessed Round LED fixture and LED Light, 3500 K warm output. x1
- EXHAUST RISER - Factory installed 8" Diameter X 4" Height x1
- 1/2 Pint Grease Cup New Style, Flanged Slotted x1
- FIELD WRAPPER 37.00" High Front, Left, Right x1
- Face Mount 1st Switch x1
- RIGHT QUARTER END PANEL 20" Top Width, 0" Bottom Width, 20" High 430 SS x1
- LEFT QUARTER END PANEL 20" Top Width, 0" Bottom Width, 20" High 430 SS x1

Hood #2 - KH-2 - Job #7499687

- 3044BD-2 - 2ft 6" Long Low Proximity Sloped Backshelf Hood and a Built-In 3" Back Standoff. 14 inch Tall Front. x1

- 430 SS Where Exposed x1
- FILTER - 16" tall x 20" (15.625" by 19.625") wide Stainless Steel Captrate Solo filter with hook, ETL Listed. Particulate capture efficiency: 85% efficient at 9 microns, 76% efficient at 5 microns. Used on hoods shipped AFTER 7/27/17. x1

- Recessed Round LED fixture and LED Light, 3500 K warm output.	x1
- EXHAUST RISER - Factory installed 8" Diameter X 4" Height	x1
- 1/2 Pint Grease Cup New Style, Flanged Slotted	x1
- FIELD WRAPPER 37.00" High Front, Left, Right	x1
- Face Mount 1st Switch	x1
- RIGHT QUARTER END PANEL 20" Top Width, 0" Bottom Width, 20" High 430 SS	x1
- LEFT QUARTER END PANEL 20" Top Width, 0" Bottom Width, 20" High 430 SS	x1

Hood #3 - KH-3 - Job #7499687

3044BD-2 - 2ft 6" Long Low Proximity Sloped Backshelf Hood and a Built-In 3" Back Standoff. 14 inch Tall Front. x1

- 430 SS Where Exposed	x1
- FILTER - 16" tall x 20" (15.625" by 19.625") wide Stainless Steel Captrate Solo filter with hook, ETL Listed. Particulate capture efficiency: 85% efficient at 9 microns, 76% efficient at 5 microns. Used on hoods shipped AFTER 7/27/17.	x1
- Recessed Round LED fixture and LED Light, 3500 K warm output.	x1
- EXHAUST RISER - Factory installed 8" Diameter X 4" Height	x1
- 1/2 Pint Grease Cup New Style, Flanged Slotted	x1
- FIELD WRAPPER 37.00" High Front, Left, Right	x1
- Face Mount 1st Switch	x1
- RIGHT QUARTER END PANEL 20" Top Width, 0" Bottom Width, 20" High 430 SS	x1
- LEFT QUARTER END PANEL 20" Top Width, 0" Bottom Width, 20" High 430 SS	x1

Hood #4 - KH-4 - Job #7499687

3044BD-2 - 2ft 6" Long Low Proximity Sloped Backshelf Hood and a Built-In 3" Back Standoff. 14 inch Tall Front. x1

- 430 SS Where Exposed	x1
- FILTER - 16" tall x 20" (15.625" by 19.625") wide Stainless Steel Captrate Solo filter with hook, ETL Listed. Particulate capture efficiency: 85% efficient at 9 microns, 76% efficient at 5 microns. Used on hoods shipped AFTER 7/27/17.	x1
- Recessed Round LED fixture and LED Light, 3500 K warm output.	x1
- EXHAUST RISER - Factory installed 8" Diameter X 4" Height	x1
- 1/2 Pint Grease Cup New Style, Flanged Slotted	x1
- FIELD WRAPPER 37.00" High Front, Left, Right	x1
- Face Mount 1st Switch	x1
- RIGHT QUARTER END PANEL 20" Top Width, 0" Bottom Width, 20" High 430 SS	x1
- LEFT QUARTER END PANEL 20" Top Width, 0" Bottom Width, 20" High 430 SS	x1

Hood #5 - KH-5 - Job #7499687

3044BD-2 - 5ft 6" Long Low Proximity Sloped Backshelf Hood and a Built-In 3" Back Standoff. 14 inch Tall Front. x1

- 430 SS Where Exposed	x1
- FILTER - 16" tall x 16" (15.625" by 15.625") wide Stainless Steel Captrate Solo filter with hook, ETL Listed. Particulate capture efficiency: 85% efficient at 9 microns, 76% efficient at 5 microns. Used on hoods shipped AFTER 7/27/17.	x4
- Recessed Round LED fixture and LED Light, 3500 K warm output.	x2

- EXHAUST RISER - Factory installed 10" Diameter X 4" Height x1
- 1/2 Pint Grease Cup New Style, Flanged Slotted x1
- FIELD WRAPPER 37.00" High Front, Left, Right x1
- Face Mount 1st Switch x1
- RIGHT QUARTER END PANEL 20" Top Width, 0" Bottom Width, 20" High 430 SS x1
- LEFT QUARTER END PANEL 20" Top Width, 0" Bottom Width, 20" High 430 SS x1

Fan #1 DU12HFA - Exhaust Fan (KEF-1) - Job #7499687

DU12HFA High Speed Direct Drive Centrifugal Upblast Exhaust Fan with speed control (speed control included for single phase only), disconnect switch and 10-1/2" wheel. x1
 Exhaust Fan handles 375 CFM @ -0.350" wc ESP, Fan runs at 1431 RPM.
 Exhaust Motor: 0.250 HP, 1 Phs, 115 V, 60 Hz, 2.9 FLA, TEAO-ECM (Totally Enclosed Air Over Electronically Commutated Motor)

- Grease Cup for kitchen-duty centrifugal exhaust fans, x1
 Box Dimensions 17-1/8 L X 5-1/16 W X 3-3/4 H (20 Gauge) (Includes Down Spout)
- DU/DR12HFA Gasketing Kit - Thermeez Woven Ceramic Tape - 1/4" x 1" with adhesive back - Max Temp 1500°F. To be applied between fan base and grease duct. Installed under fan base 1/2" from the inside edge of the base to match up with the curb top flanges. Installed at the plant. x1
- ECM Wiring Package and Manual or 0-10VDC Control for Exhaust EC motors. MSC Controller. x1
 DO NOT ORDER UNDER WARRANTY, SEE PART NUMBER "CAS MSC.
- KEF-1 Curb CRB17.5x24E Insulated On Fan #1 Flat Curb x1
- Hinged Base for Curb. Standard Hinge attached to curb. Used on Fans with wheels 20 inches or smaller. 12 GA Galvanized. x1
- Vented Base for Curb x1

Fan #2 DU12HFA - Exhaust Fan (KEF-2) - Job #7499687

DU12HFA High Speed Direct Drive Centrifugal Upblast Exhaust Fan with speed control (speed control included for single phase only), disconnect switch and 10-1/2" wheel. x1
 Exhaust Fan handles 375 CFM @ -0.350" wc ESP, Fan runs at 1431 RPM.
 Exhaust Motor: 0.250 HP, 1 Phs, 115 V, 60 Hz, 2.9 FLA, TEAO-ECM (Totally Enclosed Air Over Electronically Commutated Motor)

- Grease Cup for kitchen-duty centrifugal exhaust fans, x1
 Box Dimensions 17-1/8 L X 5-1/16 W X 3-3/4 H (20 Gauge) (Includes Down Spout)
- DU/DR12HFA Gasketing Kit - Thermeez Woven Ceramic Tape - 1/4" x 1" with adhesive back - Max Temp 1500°F. To be applied between fan base and grease duct. Installed under fan base 1/2" from the inside edge of the base to match up with the curb top flanges. Installed at the plant. x1
- ECM Wiring Package and Manual or 0-10VDC Control for Exhaust EC motors. MSC Controller. x1
 DO NOT ORDER UNDER WARRANTY, SEE PART NUMBER "CAS MSC.
- KEF-2 Curb CRB17.5x24E Insulated On Fan #2 Flat Curb x1
- Hinged Base for Curb. Standard Hinge attached to curb. Used on Fans with wheels 20 inches or smaller. 12 GA Galvanized. x1
- Vented Base for Curb x1

Fan #3 DU12HFA - Exhaust Fan (KEF-3) - Job #7499687

DU12HFA High Speed Direct Drive Centrifugal Upblast Exhaust Fan with speed control (speed control included for single phase only), disconnect switch and 10-1/2" wheel. x1
 Exhaust Fan handles 375 CFM @ -0.350" wc ESP, Fan runs at 1431 RPM.
 Exhaust Motor: 0.250 HP, 1 Phs, 115 V, 60 Hz, 2.9 FLA, TEAO-ECM (Totally Enclosed Air Over Electronically Commutated Motor)

- Grease Cup for kitchen-duty centrifugal exhaust fans, x1
 Box Dimensions 17-1/8 L X 5-1/16 W X 3-3/4 H (20 Gauge) (Includes Down Spout)

- DU/DR12HFA Gasketing Kit - Thermeez Woven Ceramic Tape - 1/4" x 1" with adhesive back - Max Temp 1500°F. To be applied between fan base and grease duct. Installed under fan base 1/2" from the inside edge of the base to match up with the curb top flanges. Installed at the plant. x1
- ECM Wiring Package and Manual or 0-10VDC Control for Exhaust EC motors. MSC Controller. **DO NOT ORDER UNDER WARRANTY, SEE PART NUMBER "CAS MSC**". x1
- KEF-3 Curb CRB17.5x24E Insulated On Fan #3 Flat Curb x1
- Hinged Base for Curb. Standard Hinge attached to curb. Used on Fans with wheels 20 inches or smaller. 12 GA Galvanized. x1
- Vented Base for Curb x1

Fan #4 DU12HFA - Exhaust Fan (KEF-4) - Job #7499687

- DU12HFA High Speed Direct Drive Centrifugal Upblast Exhaust Fan with speed control (speed control included for single phase only), disconnect switch and 10-1/2" wheel. x1
Exhaust Fan handles 375 CFM @ -0.350" wc ESP, Fan runs at 1431 RPM.
Exhaust Motor: 0.250 HP, 1 Phs, 115 V, 60 Hz, 2.9 FLA, TEAO-ECM (Totally Enclosed Air Over Electronically Commutated Motor)
- Grease Cup for kitchen-duty centrifugal exhaust fans, x1
Box Dimensions 17-1/8 L X 5-1/16 W X 3-3/4 H (20 Gauge) (Includes Down Spout)
- DU/DR12HFA Gasketing Kit - Thermeez Woven Ceramic Tape - 1/4" x 1" with adhesive back - Max Temp 1500°F. To be applied between fan base and grease duct. Installed under fan base 1/2" from the inside edge of the base to match up with the curb top flanges. Installed at the plant. x1
- ECM Wiring Package and Manual or 0-10VDC Control for Exhaust EC motors. MSC Controller. **DO NOT ORDER UNDER WARRANTY, SEE PART NUMBER "CAS MSC**". x1
- KEF-4 Curb CRB17.5x24E Insulated On Fan #4 Flat Curb x1
- Hinged Base for Curb. Standard Hinge attached to curb. Used on Fans with wheels 20 inches or smaller. 12 GA Galvanized. x1
- Vented Base for Curb x1

Electrical System #1 - Job #7499687

- 1st Switch x1

Electrical System #2 - Job #7499687

- 1st Switch x1

Electrical System #3 - Job #7499687

- 1st Switch x1

Electrical System #4 - Job #7499687

- 1st Switch x1

Electrical System #5 - Job #7499687

- 1st Switch

Installation of these products should be performed by a qualified professional who has read and understands the product manuals and is familiar with the proper safety precautions.

By Others:

Installation, receiving, hanging and setting of equipment, ductwork, patching, all electrical field wiring, start-up & balance, gas or electric shutdown for fire system hook-up, **field piping, detection and pull station line(s), tests and permits.** Checking equipment for any signs of damage upon receipt, and if found, report it immediately to the carrier. Check that all items are accounted for and free of damage.

Note:

Customer is responsible for additional labor charges as a result of cooking equipment layout changes after the release of the order, union labor or prevailing wage charges, or additional trips by fire system distributor caused by jobsite delays, permits, fees or test required by local authority. Submittal will specify applicable testing and approval agencies.

The fire suppression system final hook up is not included on this quote. The final hook up usually consists of, but is not limited to, field piping/re-piping, detection and pull station line(s), tests, and permits.

Hook up for the fire system must be performed in accordance with the product manual by a Factory Trained Distributor. Failure to utilize a factory trained distributor voids the product warranty.

Econ-Air requirement for all field hook ups:

All fire system installation materials and methods must be in accordance with the product manual, which includes but not limited to: fire system piping, gas shut-off valves, low-voltage wiring and conduit, verification of appliance coverage, and start-up and inspection procedures.

Econ-Air product must be installed in accordance with installation instructions provided with equipment or available on our web site at www.econair.com.

Ductwork must be designed and installed in accordance with AMCA and ASHRAE standards as presented in Econ-Air "Guide to Designing Air Flow Systems", available [here](#).

Hood and Ductwork hanging brackets and angles must be supported with 1/2" - 13 TPI grade 5 (minimum) all-thread. Sandwich hanging angles and ceiling anchor points with 1/2" grade 5 (minimum) steel flat washers and 1/2" - 13 TPI grade 5 (minimum) hex nuts. A doubled hex nut configuration must be used beneath hood and duct hanging brackets and above ceiling anchors (single hex nut beneath hanging angle is only acceptable for full length and supply plenum hanging angle types). Maintain 1/4" of exposed threads beneath bottom hex nut. Torque all hex nuts to 57 ft-lbs. Reference the installation manual for additional details and limitations of all structural supports.

WARRANTY

Standard Product Warranty

This equipment is warranted to be free from defects in materials and workmanship, under normal use and service, for a period of 2-years from date of shipment.

Warranty Instructions

This Standard Product Warranty shall not apply if:

1. The equipment is not installed by a qualified installer per the MANUFACTURER'S installation instructions shipped with the product.
2. The equipment is not installed in accordance with federal, state and local codes and regulations.
3. The equipment is misused or neglected, or not maintained per the MANUFACTURER'S maintenance instructions.
4. The equipment is not operated within its published capacity.
5. The invoice is not paid within the terms of the sales agreement.

The MANUFACTURER shall not be liable for incidental and consequential losses and damages potentially attributable to malfunctioning equipment. Should any part of the equipment prove to be defective in material or workmanship within the **Standard Product Warranty**, upon examination by the MANUFACTURER, such part will be repaired or replaced by MANUFACTURER at no charge. The BUYER shall pay all labor costs incurred in connection with such repair or replacement. Equipment shall not be returned without MANUFACTURER'S prior authorization and all returned equipment shall be shipped by the BUYER, freight prepaid to a destination determined by the MANUFACTURER.

NOTE: To receive warranty coverage, register this product by filling out the Start-up and Maintenance Document. Fax the form to 1-919-554-9374 or call 1-866-784-6900 for email information.

SHIPPING

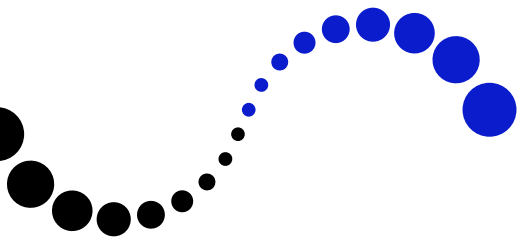

**CENTENNIAL
PUBLIC SCHOOL**



ANNUAL REPORT 2024-2025

**COMMUNITIES UNITED
FOR A BRIGHTER
TOMORROW**

**OUR MISSION:
EMPOWER,
CHALLENGE, AND
SUPPORT EVERY
STUDENT, EVERY DAY**



MAY - 2025



(402) 534-2321

WWW.CENTENNIALBRONCOS.ORG

**FINANCIAL
INFORMATION**

GENERAL FUND LEVY - \$.433725
BOND FUND LEVY - \$.046347
SPECIAL BUILDING LEVY - \$.034905
TOTAL LEVY - \$.514977
VALUATION PER EACH PK-12 STUDENT - \$3,378,813



**FINANCIAL
RESPONSIBILITY**

**10 YEAR AVERAGE GENERAL FUND EXPENDITURE
INCREASE - 3.18%**
**10 YEAR AVERAGE GENERAL FUND TAX ASKING
INCREASE - 2.78%**
TOTAL ASSESSED VALUATION - \$1,740,088,893
AG LAND - \$1,246,937,172
OTHER PROPERTY - \$517,048,669

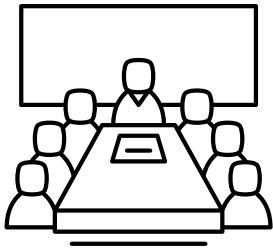

BOARD OF EDUCATION



DOUG CAST, TREASURER
BRYCE BORCHERS
JASON RICHTERS, PRESIDENT
LANA HOFFSCHNEIDER, VICE PRESIDENT
DEREK TOMES, SECRETARY
COLE HENDERSON

**Board members are elected to four-year terms
with half of the board up for election every
two years.**

**CENTENNIAL
CHOICE**

**Chad Ehlers, Nathan Baack, Spencer Clouse, Cole Henderson,
Kevin Naber, Ross Cradick, Wade Heine, Keaton Kucera, and
Chad Hoffschneider**



**In partnership with producers in our community,
along with supporters of Centennial, we have
made the commitment to bring farm raised beef
and pork to the students of Centennial. Students
enjoy high quality, delicious tasting Nebraska
beef and pork, benefiting the student while
promoting our local ag producers.**



PK-12 ENROLLMENT

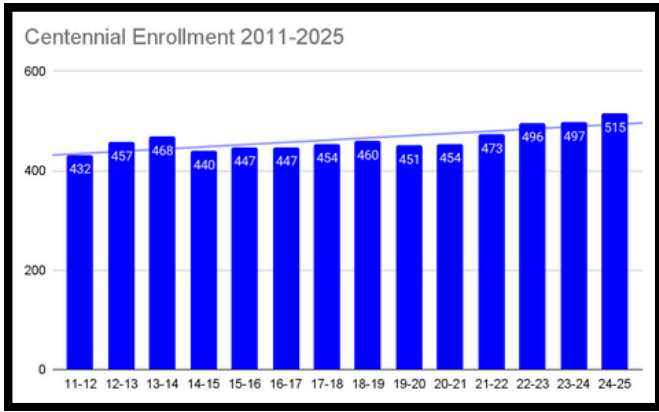

2011 Enrollment
432
2022 Enrollment
496
2025 Enrollment
515

- Trend has been stable with a small increase in enrollment since 2011
- Increase in participation in preschool
- Housing developments in communities indicate we could sustain this growth in coming years.

WINTER MAPS TESTING

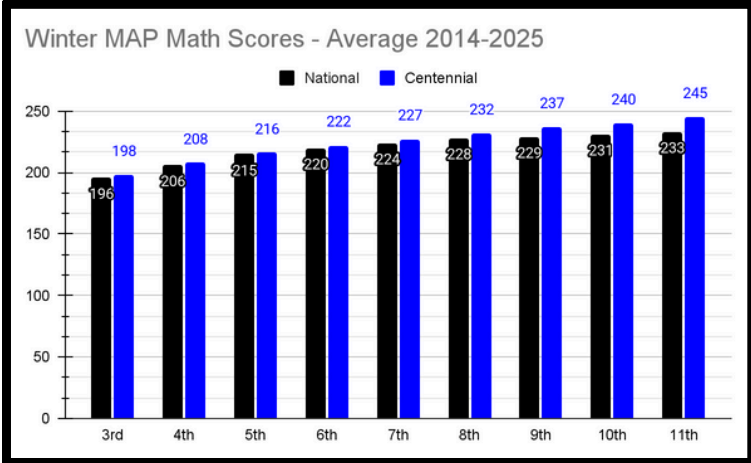
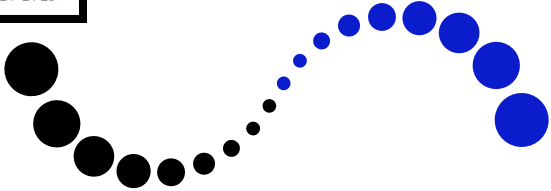

MATH

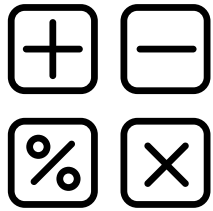
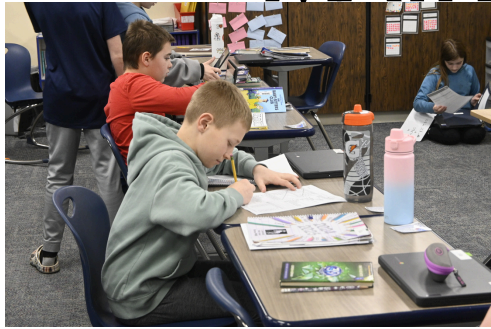

READING

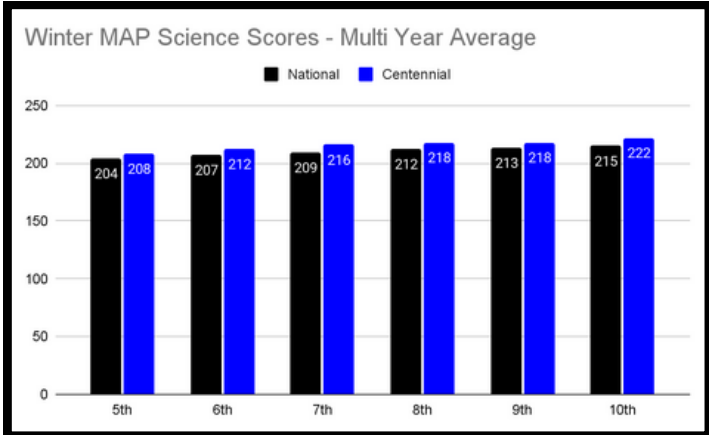
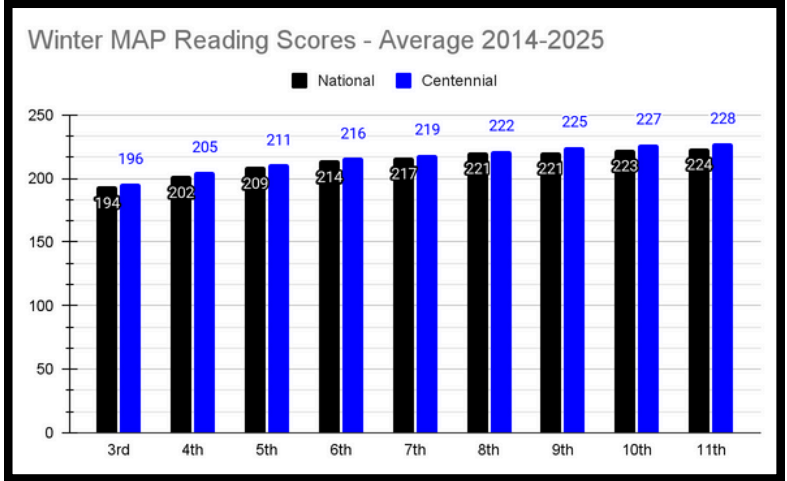
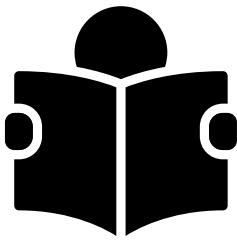

SCIENCE

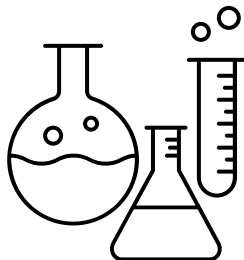

MATH

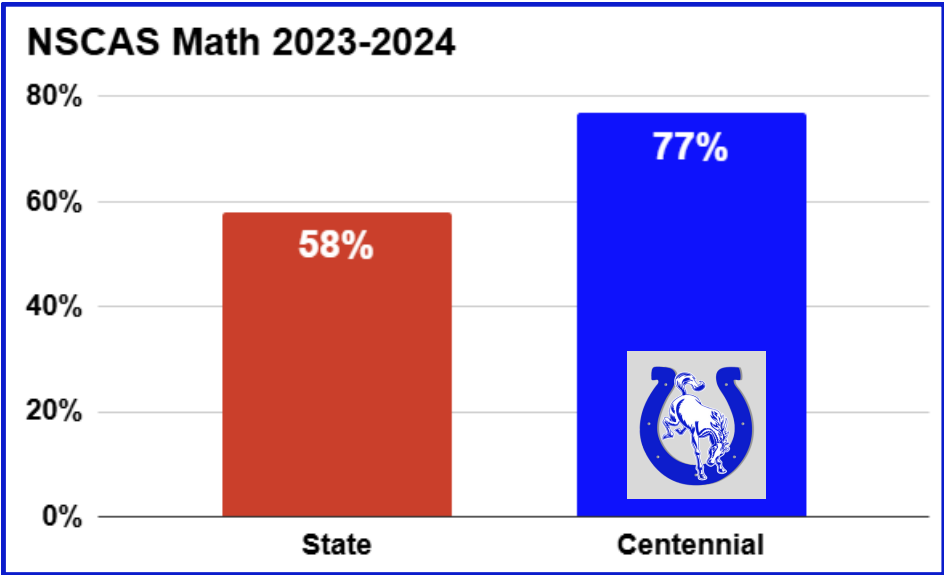

NSCAS English Language Arts 2023-2024

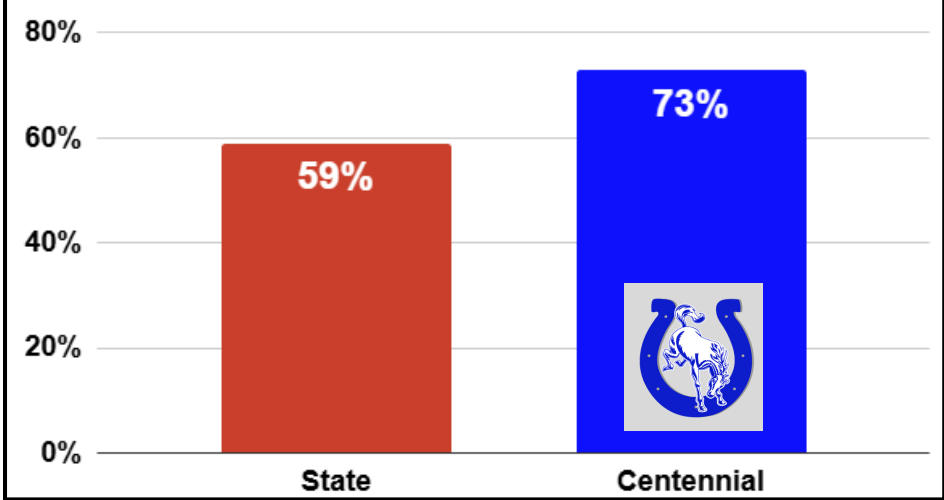

ELA



SCIENCE

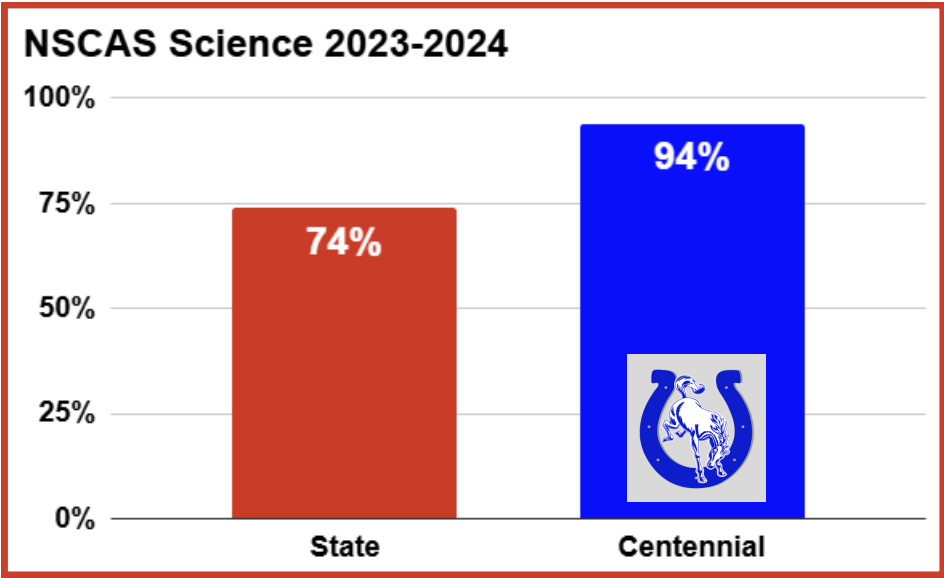

AVERAGE ACT SCORES FOR THE LAST 7 YEARS

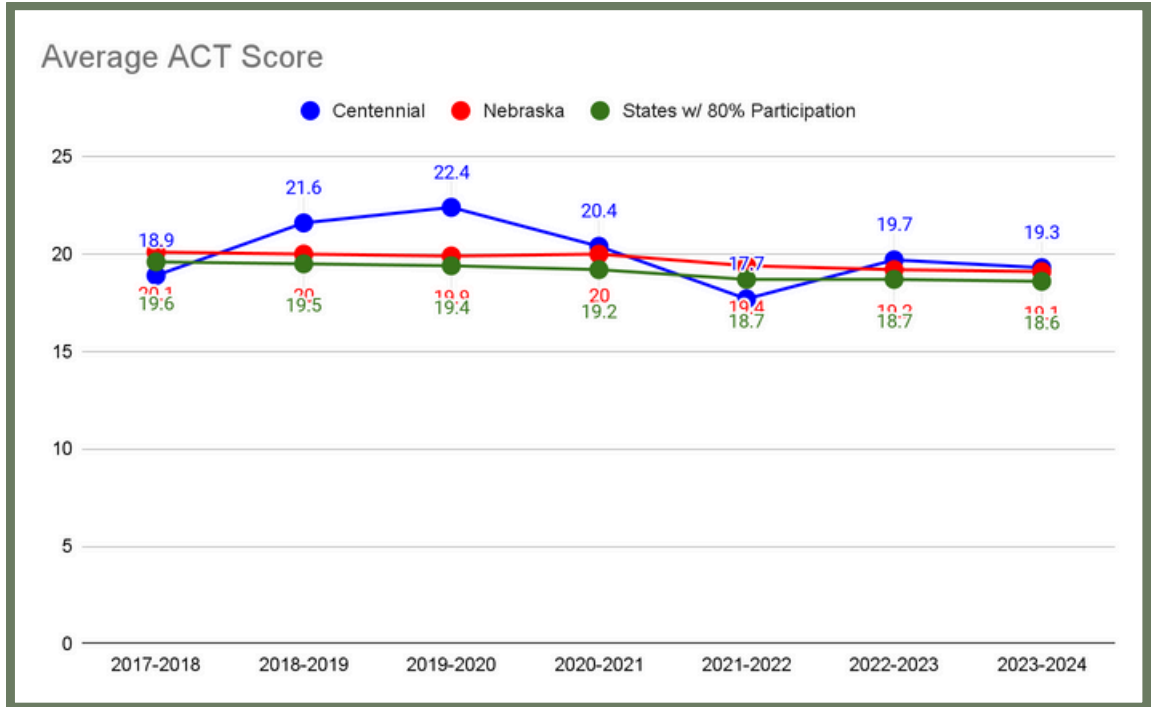

NEBRASKA ACT AVERAGE SCORE RANK AMONG STATES WITH 80% PARTICIPATION RATES



Graduation Year	2017-2018	2018-2019	2019-2020	2020-2021	2021-2022	2022-2023	2023-2024
Rank	7th	4th	5th	3rd	2nd	2nd	5th

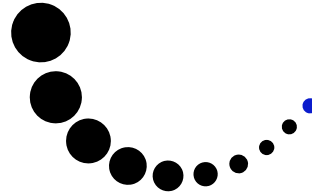

CERTIFIED STAFF

- 5 Administrators - Superintendent, Secondary Principal (6-12), Elementary Principal (PreK-5), Activities Director/Assistant Principal and Director of Special Services
- 44 Teachers
- 2 Guidance Counselors
- 1 Media Specialist/Technology Integrationist
- 1 Speech/Language Pathologist
- 1 Operations Director/Technology Coordinator

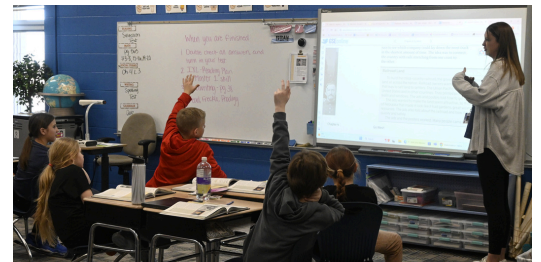

CONTRACTED SERVICES

- Licensed Mental Health Practitioner
- Occupational Therapist
- Physical Therapist
- School Psychologist
- Teacher for Visually Impaired
- Teacher for Hearing Impaired

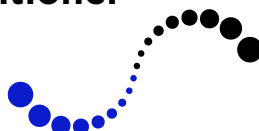

SUPPORT STAFF

- **16 Paraprofessionals** - Paraprofessional assistance is provided to our elementary teachers, preschool teachers, resource teachers, Title 1 teachers and media specialist.
- **6 Food Service Staff** - A high quality daily breakfast and lunch is served each day with a fruit and vegetable bar available each day.
- **1 Full-time Nurse** - Provides the many varied health services necessary for all students.
- **6 Maintenance Staff** - Responsible for cleaning and keeping facilities in good repair.
- **6 Secretarial and Bookkeeping staff** - Responsible for performing a variety of functions ranging from serving as receptionists, maintaining records, typing correspondence, selling lunch tickets, preparing the newsletter, reports, budgetary accounting, payroll, and other tasks.
- **9 Transportation Staff** - Safely transporting our students along ten regular am and pm routes, two mid-day preschool routes, and one special education route operate daily to transport an estimated 350 students.
- **Not included in the above numbers are additional substitute teachers, substitutes for various support staff, and valuable volunteers.**

FACILITY FACTS

- 1977 - A 100,000 square foot school was built on a 40 acre site in Utica.
- 1988 - A 3,840 square foot addition of a weight room/wrestling practice area.
- 1992 - A 12,000 square foot elementary addition.
- 1997 - A 7,650 square foot secondary addition (three classrooms and a girls locker room).
- 2009 - A 22,000 square foot addition of a Performing Arts Center.
- 2015 - A 50,000 square foot addition of new Jr. and Sr. High Science classrooms, Vocational Ag and Industrial Arts classrooms and shops, and a new competition gym and locker rooms.
- 2017 - New concessions stand and restrooms at the football field/track.
- Two additional auxiliary buildings are also located in Utica.

FACILITY IMPROVEMENTS



North Sidewalk

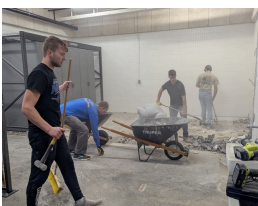

Makerspace

- North student parking lot sidewalk and fence replacement
- Fiber optic network expansion to football/track pressbox
- Replacement of all network switches
- Replacement of a portion of security cameras
- North boys locker room exhaust improvements
- Special education classroom renovations (flooring/ceiling/lighting/painting) and ADA restroom addition
- Old visitor locker room conversion into a makerspace
- Installation of additional hanging baffles in west gym to improve acoustics
- New entry doors on the east and west side of the building
- North driveway/parking joint sealing



SPED Classrooms

9 - 12 CURRICULUM

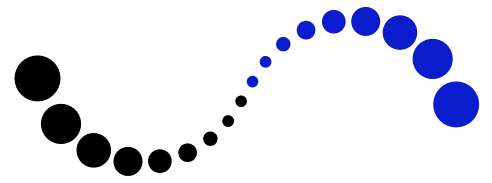

A comprehensive curriculum includes:

- Business Education
- Driver Education (Summer Only)
- Fine/Performing Arts (Art, Band, and Vocal Music)
- Spanish
- Family and Consumer Science
- JAG (Jobs for America's Graduates)
- Industrial Technology
- Computer Science
- Mathematics
- Physical Education
- English Language Arts
- Science
- Social Sciences
- Special Education

- Digital Design/Digital Media
- Vocational Education (Welding, Health Sciences, Criminal Justice, Education Pathway, Zoology, Tech Services, Business, and Internship opportunities)

Dual Credit Education classes are offered in:

- Calculus
- Education Pathway
- English
- College Algebra
- Welding

Additional Dual Credit is offered through SCC SENCAP.

Centennial students have experienced much success in a host of various academic competitions at the local, state, regional, and national levels.



FBLA MEMBERS QUALIFIING FOR THE NATIONAL LEADERSHIP CONFERENCE IN ANAHEIM, CALIFORNIA, THIS SUMMER!



- Parliamentary Procedure 1st Place Team - Meg Hoffschneider, Hope Galley, Dakota Boyer, Riley Ziegler
- Hope Galley - 1st Place in Word Processing and 2nd Place in Computer Apps
- Tyson Hornbacher - 3rd Place in Intro to Information Tech
- Sam Ehlers - 5th Place in Agribusiness



empowering tomorrow's leaders

ED RISING MEMBERS QUALIFIING FOR NATIONALS AND HEADING TO ORLANDO, FLORIDA, THIS SUMMER!

- Lauryn Breitreutz
- Kobie Kosek
- Sarah Payne
- Danika Smith



ELEMENTARY ACTIVITIES

- 5th Grade Band
- Music and PE Every Day (K-2nd)
- Spelling Bee
- TeamMates
- Student Voice Groups
- Bronco Buddies
- Girls on the Run
- 4H After School Clubs
- Banking with Jones Bank
- Elementary Family Nights
- PTO Fun Night

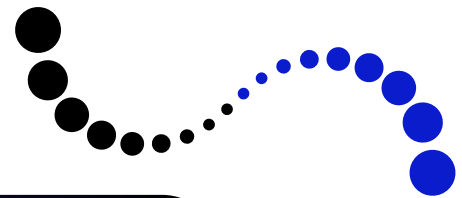

MIDDLE SCHOOL ACTIVITIES & ATHLETICS

- 6-8th Grade Band
- Pep/Marching Band
- Spelling Bee
- TeamMates
- Quiz Bowl
- Bronco Buddies
- FBLA (7th & 8th)
- FCCLA (7th & 8th)
- FFA(7th & 8th)
- Musical - Stage/Sound Booth
- Unified Bowling (7th & 8th)
- E-Sports
- Football (Boys)
- Volleyball (Girls)
- Cross Country (Boys and Girls)
- Basketball (Boys and Girls)
- Wrestling (Boys and Girls)
- Track (Boys and Girls)



HIGH SCHOOL ACTIVITIES

- Concert Band
- Jazz Band
- Pep/Marching Band
- Drama (One Act)
- Choir
- Show Choir
- Musical
- Student Council
- TeamMates
- Quiz Bowl
- Future Farmers of America
- Family, Career and Community Leaders of America
- Future Business Leaders of America
- E-Sports
- Speech Team
- Cheer
- Dance Team
- Yearbook
- Ed Rising



	Revenue	Payroll Totals	Bill Totals	Expense Totals	Revenue/Expense Differential
September					
22-23	\$1,563,086	\$638,324	\$225,472	\$863,796	\$699,290
23-24	\$1,697,991	\$660,804	\$195,350	\$856,154	\$841,837
24-25	\$1,199,622	\$700,275	\$263,631	\$963,906	\$235,716
Average	\$1,486,900	\$666,468	\$228,151	\$894,619	\$696,694
October					
22-23	\$515,470	\$641,805	\$102,588	\$744,392	-\$228,922
23-24	\$506,570	\$673,151	\$110,037	\$783,188	-\$276,618
24-25	\$580,601	\$658,229	\$123,335	\$781,564	-\$200,963
Average	\$534,214	\$657,728	\$111,987	\$769,715	-\$246,482
November					
22-23	\$122,074	\$635,248	\$114,671	\$749,918	-\$627,844
23-24	\$227,218	\$679,291	\$130,518	\$809,809	-\$582,591
24-25	\$120,735	\$758,390	\$85,814	\$844,204	-\$723,469
Average	\$156,676	\$690,976	\$110,334	\$801,310	-\$612,983
December					
22-23	\$185,764	\$621,091	\$95,341	\$716,432	-\$530,668
23-24	\$257,104	\$661,685	\$224,987	\$886,672	-\$629,568
24-25	\$506,257	\$701,707	\$117,147	\$818,854	-\$312,597
Average	\$316,375	\$310,716	\$145,825	\$807,319	-\$490,944
January					
22-23	\$1,724,396	\$585,495	\$120,330	\$705,825	\$1,018,571
23-24	\$1,997,702	\$641,898	\$172,062	\$813,960	\$1,183,742
24-25	\$1,331,733	\$675,746	\$109,912	\$785,658	\$546,074
Average	\$1,861,049	\$634,380	\$146,196	\$759,893	\$895,783
February					
22-23	\$1,209,231	\$607,215	\$157,257	\$764,472	\$444,759
23-24	\$1,242,662	\$629,631	\$78,824	\$708,455	\$534,207
24-25	\$1,502,556	\$710,061	\$79,907	\$789,967	\$712,589
Average	\$1,225,946	\$618,423	\$118,040	\$736,464	\$358,507
March					
22-23	\$392,202	\$605,397	\$135,111	\$741,726	-\$349,524
23-24	\$464,150	\$655,712	\$170,809	\$826,521	-\$362,371
24-25	\$1,232,315	\$695,464	\$134,142	\$829,606	\$402,709
Average	\$428,176	\$630,555	\$152,960	\$784,124	-\$289,135
April					
22-23	\$938,788	\$611,829	\$191,483	\$803,312	\$135,476
23-24	\$518,048	\$619,944	\$220,399	\$840,343	-\$143,212
24-25		\$656,560	\$96,975	\$753,535	
Average	\$728,418	\$615,887	\$205,941	\$821,828	\$47,896
May					
22-23	\$1,946,599	\$614,708	\$106,911	\$721,619	\$1,224,979
23-24	\$2,646,217	\$691,606	\$142,307	\$833,913	\$1,812,304
24-25		\$702,535	\$175,092	\$877,627	
Average	\$2,296,408	\$653,157	\$124,609	\$777,766	\$1,334,149
June					
22-23	\$835,327	\$595,109	\$215,470	\$810,580	\$24,748
23-24	\$772,068	\$621,572	\$126,636	\$748,208	\$204,752
24-25					
Average	\$803,698	\$608,341	\$171,053	\$779,394	\$104,650
July					
22-23	\$127,337	\$525,701	\$155,067	\$680,768	
23-24	\$280,620	\$546,113	\$142,646	\$688,759	
24-25					
Average	\$203,978	\$535,907	\$148,857	\$684,763	-\$638,906
August					
22-23	\$89,966	\$532,878	\$488,582	\$1,021,460	
23-24	\$221,095	\$575,304	\$589,868	\$1,165,172	
24-25					
Average	\$155,530	\$554,091	\$539,225	\$1,093,316	-\$532,645

	2024-2025 Disbursements					
Month	Total Expenditures	Cumulative Spent	% of Budget	Average % of Budget	Cum. % of Budget Spent	Average % Spent
September	\$963,906	\$963,906	9.51%	8.93%	9.51%	8.93%
October	\$781,564	\$1,745,470	7.71%	7.91%	17.22%	16.84%
November	\$844,204	\$2,589,674	8.33%	8.10%	25.55%	24.94%
December	\$818,854	\$3,408,528	8.08%	8.28%	33.62%	33.22%
January	\$785,658	\$4,194,186	7.75%	7.88%	41.37%	41.10%
February	\$789,967	\$4,984,153	7.79%	7.66%	49.17%	48.76%
March	\$829,606	\$5,813,759	8.18%	8.13%	57.35%	56.89%
April	\$753,535	\$6,567,294	7.43%	8.53%	64.78%	65.42%
May	\$877,627	\$7,444,921	8.66%	8.05%	73.44%	73.47%
June		\$7,444,921	0.00%	8.10%	73.44%	81.57%
July		\$7,444,921	0.00%	7.11%	73.44%	88.68%
August		\$7,444,921	0.00%	11.32%	73.44%	100.00%
2024-25 Budgeted Disbursements	\$10,137,326					
	Cumulative:					
	September	October	November	December	January	February
Projected Expenses	\$905,263	\$1,707,126	\$2,528,249	\$3,367,620	\$4,166,441	\$4,942,960
Actual Expenses	\$963,906	\$1,745,470	\$2,589,674	\$3,408,528	\$4,194,186	\$4,984,153
Difference	-\$58,643	-\$38,344	-\$61,424	-\$40,908	-\$27,745	-\$41,193
	March	April	May	June	July	August
Projected Expenses	\$5,767,125	\$6,631,839	\$7,447,893	\$8,269,017	\$8,989,781	\$10,137,326
Actual Expenses	\$5,813,759	\$6,567,294	\$7,444,921	\$7,444,921	\$7,444,921	\$7,444,921
Difference	-\$46,635	\$64,545	\$2,973	\$824,096	\$1,544,860	\$2,692,405

