

HICKMAN COUNTY BOARD OF EDUCATION
REGULAR BOARD MEETING---May 4, 2020

The Hickman county Board of Education met on May 4, 2020, at 7:00 PM in Room 203 of the Central Office Building.

Call To Order

Approval of March 2, 2020 Regular Board Meeting Minutes

Approval of Agenda

Communications to the Board

Director's Report

Financial Report

TSBA OPEB Quarterly Investment Report

Land For Sale Behind HCMS

Items Requiring Board Action

Budget Amendments

Textbook Adoption

Resolution 20-01

Resolution 20-02

Resolution 20-03

ATSI Technology Purchase

Maintenance Tractor Equipment

School Painting Services

HVAC Services and Repair

Security Doors at HCHS

Concrete Work Services

School Security Cameras

2020-2021 141, 142, 143 School Budgets

Addition of Board Policies 1.8011, 5.1151, 5.3051 (1st Reading-Waive 2nd Reading)

Grading Procedures

Supplemental Pay for COVID-19 Services

HICKMAN COUNTY BOARD OF EDUCATION
REGULAR BOARD MEETING---May 4, 2020

Virtual School

EHMS Gym Floor

Declaration of Surplus

Revised Board Policies 4.2013, 3.204, 4.302, 4.606 (2nd Reading)

Board Policy Review 4.408--4.607

Announcements

Special Called May Board Meeting

Adjourn

Monday, March 2, 2020
REGULAR BOARD MEETING MINUTES

The Hickman County Board of Education met in regular session on Monday, March 2, 2020, at 7:00 p.m. in room 203 of the Central Office building. School board members in attendance at the meeting were Chair Amy Bryant, Tim Hobbs, Ron Gammons, Jane Herron, Vance Willis, and Jim Hudgins. Steve Gianakos attended the meeting virtually.

Jane Herron made a motion to approve the minutes from the board meeting held on February 3, 2020. Jim Hudgins seconded the motion.

Monday, February 3, 2020
REGULAR BOARD MEETING MINUTES

The Hickman County Board of Education met in regular session on Monday, February 3, 2020, at 7:00 p.m. in room 203 of the Central Office building. School board members in attendance at the meeting were Chair Amy Bryant, Tim Hobbs, Steve Gianakos, Ron Gammons, Jane Herron, Vance Willis, and Jim Hudgins.

Steve Gianakos made a motion to approve the minutes from the meeting held on Monday, January 6, 2020. Jane Herron seconded the motion.

Monday, January 6, 2020
REGULAR BOARD MEETING MINUTES

The Hickman County Board of Education met in regular session on Monday, January 6, 2020, at 7:00 p.m. in room 203 of the Central Office building. School board members in attendance at the meeting were Chair Amy Bryant, Tim Hobbs, Steve Gianakos, Ron Gammons, and Jane Herron. Jim Hudgins and Vance Willis were absent from the meeting.

Tim Hobbs made a motion to approve the minutes from the meeting held on December 2, 2019. Steve Gianakos seconded the motion. On a voice vote the motion was approved 5-0.

Steve Gianakos made a motion to amend the agenda to add revised board policies 6.300 and 6.312 on first reading to item E. Revised Board Policies. Ron Gammons seconded the motion. On a voice vote, the motion was approved 5-0.

Ron Gammons made a motion to approve the amended agenda. Jane Herron seconded the motion.

The Hickman County Board of Education will meet in regular session on Monday, January 6, 2020, at 7:00 p.m. in Room 203 at the Central Office. A work session will be held at 6:00 p.m. in Room 203 of the Central Office.

- I. Call to Order
- II. Approval of December 2, 2019 Regular Board Meeting Minutes
- III. Approval of Agenda

On a voice vote, the motion was approved 5-0.

Ron Gammons made a motion to accept the Financial Report. Jane Herron seconded the motion. On a voice vote, the motion was approved 5-0.

Steve Gianakos made a motion to approve Budget Amendment #5. Ron Gammons seconded the motion.

<u>Aye</u>	<u>Nay</u>	<u>Pass</u>	<u>Absent</u>
Amy Bryant			
Ron Gammons			
Steve Gianakos			
Jane Herron			
Tim Hobbs			
			Jim Hudgins
			Vance Willis

On a roll call vote, the motion was approved 5-0.

Tim Hobbs made a motion to approve the HCHS auditorium stage ADA Ramp quote from EZ Access. Steve Gianakos seconded the motion.

<u>Aye</u>	<u>Nay</u>	<u>Pass</u>	<u>Absent</u>
Amy Bryant			
Ron Gammons			
Steve Gianakos			
Jane Herron			
Tim Hobbs			
			Jim Hudgins
			Vance Willis

On a roll call vote, the motion was approved 5-0.

Steve Gianakos made a motion to approve Resolution 19-02. Jane Herron seconded the motion.

Resolution No. 19-02

Guidelines to Govern the Hickman County Board of Education's GASB 45 Trust

WHEREAS, A contract with the Hickman County Education Association (HCEA) established a medical insurance premium payments for retired teachers; and

WHEREAS, The Hickman County Board of Education entered into an agreement with the Tennessee School Boards Association's GASB 45 Trust ("the Trust" or "Trust") to fund such a program; and

WHEREAS, The contract with the HCEA expired on June 30, 2014; and

WHEREAS, The Hickman County Board of Education adopted Resolution 16-01 in order to establish new rules and regulations to govern participation and expenditures relative to the Trust and its recipients; and

WHEREAS, The Hickman County Board of Education now desires to establish new rules and regulations to govern participation and expenditures relative to the Trust and its recipients from henceforth;

NOW, THEREFORE, BE IT RESOLVED by the Board of Education in Hickman County, Tennessee, assembled in regular session this 6th day of January 2020 that:

Section 1: The Trust is applicable (i.e., open to participation) to those licensed employees according to the guidelines set forth herein, who meet the following criteria:

- A. Licensed employees who were hired on or before June 30, 2015, or;
- B. Licensed employees who were employed by the Hickman County School System during the time the Trust has been in effect from its inception through June 30, 2015, and who left the Hickman County School System and then became re-employed by the Hickman County School System on or after July 1, 2015.

Section 2: To be eligible to participate in receiving funds from the Trust, an employee must meet all of the requirements of this Resolution, must complete state and local forms at the time of filing for retirement, which must be no later than the date of the last payroll payment for the school year in which the employee is retiring.

Section 3: For those not eligible for Medicare at the time of retirement, the Board will contribute the following from the time of retirement until the retiree becomes eligible for Medicare or for a maximum of six (6) years, whichever comes first. However, if a retiring teacher has provided 35 or more years of continuous service in the Hickman County School System, premiums will be paid for a maximum of ten (10) years or until retiree becomes eligible for Medicare, whichever comes first, according to the following schedule:

- A. 30 or more years of service in Hickman County Schools
 - 1. 55% of a single policy premium
 - 2. 30% of a family policy premium
- B. 20-29 years of service in Hickman County Schools
 - 1. 45% of a single family policy premium
 - 2. 25% of a family policy premium
- C. 10-19 years of service in Hickman County Schools

1. 35% of a single policy premium
2. 15% of a family policy premium

Section 4: Retirees who meet the following conditions shall be eligible for reimbursement for Medicare supplement insurance in accordance with the schedule set below:

- A. Must meet State of Tennessee requirements to enroll in the State of Tennessee plan for Medicare supplement insurance:
- B. Are eligible for Medicare at the time of retirement; or
- C. Become eligible for Medicare after participating in Section 3, above;
- D. Medicare supplement payments shall be paid as a reimbursement, one time per year, in the month of December, according to the following rate schedule:
 - (i) Retirees with 30 or more years of service in the Hickman County Schools shall receive a local contribution, which when combined with the State of Tennessee contribution, shall equal 100% of premium cost.
 - (ii) Retirees with 20-29 years of service in the Hickman County Schools shall receive a local contribution, which, shall equal 35% of premium cost.
 - (iii) Retirees with 10-19 years of service in the Hickman County Schools shall receive a local contribution, which, shall equal 25% of premium cost.

Section 5: Upon exhaustion of funds in the Trust, membership in the Trust is abolished. If sufficient funds are not available to make a complete payment during any fiscal year to eligible retirees participating in the Trust, the remaining Trust funds are to be prorated and each participant will receive an equal share, with the exception if there is an odd amount, the last eligible participant, arranged alphabetically, will receive an odd amount to zero the Trust account out.

Section 6: The Board hereby ratifies and approves all Medicare supplement payments which have been made to any retirees since the expiration of the Agreement between the Board of Education and the Hickman County Education Association, subject to approval by the State of Tennessee and applicable rules and regulations.

Adopted, this 6th day of January 2020.

Action:

___5___ Aye ___0___ Nay ___0___ Pass ___2___ Absent

Aye:

Amy Bryant
Ron Gammons
Steve Gianakos
Jane Herron
Tim Hobbs

Absent:

Jim Hudgins
Vance Willis

Adopted:

Attest:

On a roll call vote, the motion was approved 5-0.

Amy Bryant made a motion to approve revised board policies 6.300 and 6.312 on first reading. Steve Gianakos seconded the motion. On a voice vote, the motion was approved 5-0. Jane Herron made a motion to approve revised board policies 4.201 and 6.411 on second reading. Ron Gammons seconded the motion. On a voice vote, the motion was approved 5-0.

Tim Hobbs made a motion to accept the review of board policies 3.300-3.602. Ron Gammons seconded the motion. On a voice vote, the motion was approved 5-0.

An announcement was made that a board retreat would be held on Saturday, January 25, 2020, from 8:00 a.m.-12:00 p.m. at Centerville Intermediate School.

The meeting was adjourned at 7:22 p.m.

On a voice vote, the motion was approved 6-0-1, with Vance Willis passing on the motion since he was not in attendance at the January 6 meeting.

Ron Gammons made a motion to approve the meeting agenda for February 3, 2020. Vance Willis seconded the motion.

The Hickman County Board of Education will meet in regular session on Monday, February 3, 2020, at 7:00 p.m. in Room 203 at the Central Office. A work session will be held at 6:00 p.m. in Room 203 of the Central Office.

- I. Call to Order
- II. Approval of January 6, 2020 Regular Board Meeting Minutes
- III. Approval of Agenda
- IV. Special Recognition
 - A. Employee of the Month (Vance Willis)
- V. Communications to the Board
 - A. Director's Report--Director of Schools
 - B. Financial Report--Business Officer

- C. OPEB Trust Financial Statement--Director of Schools
- VI. Items Requiring Board Action
 - A. Trip Requests--Sponsor and Students
 - 1. East Hickman High School FFA--Sponsor and Students
 - 2. Hickman County High School Girls Soccer--Coach and Players
 - 3. Hickman County High School JROTC--Sponsor and Students
 - 4. Hickman County High School JROTC--Sponsor and Students
 - 5. Hickman County High School JROTC--Sponsor and Students
 - 6. Hickman County High School JROTC--Sponsor and Students
 - B. Hickman County High School JROTC Military Formal--Sponsor and Students
 - C. Budget Amendments--Business Officer
 - D. School Bus Bids--Director of Transportation
 - E. Engine Replacement Proposal--Director of Transportation
 - F. EHES Job Share Request--Principal and Supervisor
 - G. Land for Sale behind HCMS--Director of Schools
 - H. Revised Board Policies 6.300, 6.312 (2nd Reading)--Director of Accountability
 - I. Board Policy Review 4.100-4.211--Director of Accountability
- VII. Announcements--Board Retreat scheduled for February 8, 2020 has been cancelled
- VIII. Adjourn

On a voice vote, the motion was approved 7-0.

Andrea Eubanks was recognized as February Employee of the Month by Vance Willis.

Steve Gianakos made a motion to accept the Director's Report. Ron Gammons seconded the motion.

Memorandum

To: Board Members
 From: Michelle Gilbert
 Date: January 28, 2020
 RE: February Director's Report

Leave of Absence

Professional

Robyn Emerson	FMLA (January 6-February 10, 2020)
Kim Jenkins	FMLA (January 6-February 10, 2020)

Support Staff

Hiring

Professional

Christy Uhl	Project AWARE Student Support
Jennifer Armstrong	Project AWARE Student Support
Ashley Easley	Project AWARE Student Support
Lonnie Horner	HCHS Biology (100-day contract)

Support Staff

Tracy Rivers	HCHS In-School Suspension
Sarah Eisenhuth	HCMS Special Education Assistant
Horace Dunning	Substitute Bus Driver

Resignation

Professional

Support Staff

Stephanie Bodine	EHES Special Education Assistant
------------------	----------------------------------

Retirement

Professional

Support Staff

Transfers

Professional

Support Staff

Floy Ann McCutchen

Substitute Bus Driver to Full Time Bus Driver

Jessie Waters

Substitute Bus Driver to Full Time Bus Driver

Ronnie Lewis

Substitute Bus Driver to Full Time Bus Driver

Appointment

Professional

Support Staff

Brett Lovett

HCHS Interim Head Football Coach

Open Positions

1 Music Position

1 School Counselor Position

1 Secondary Math Position

2 Special Education Positions

1 Bookkeeper Position

1 Special Education Assistant

On a voice vote, the motion was approved 7-0.

Ron Gammons made a motion to accept the Financial Report. Jim Hudgins seconded the motion. On a voice vote, the motion was approved 7-0.

Ron Gammons made a motion to approve the OPEB Trust Financial Statement. Steve Gianakos seconded the motion. On a voice vote, the motion was approved 7-0.

Tim Hobbs made a motion to approve the trip request from EHHS FFA for 9 students to attend State Convention in Gatlinburg, TN on March 29-April 1, 2020. Ron Gammons seconded the motion. On a voice vote, the motion was approved 7-0.

Ron Gammons made a motion to approve an overnight girls soccer camp at HCHS on July 19-23, 2020. Tim Hobbs seconded the motion. On a voice vote, the motion was approved 7-0.

Ron Gammons made a motion to approve a trip request for the HCHS JROTC to attend JCLC in Greenville, KY, from 6/4-6/8, 2020. Steve Gianakos seconded the motion. On a voice vote, the motion was approved 7-0.

Ron Gammons made a motion to approve a trip request for the HCHS JROTC to attend the 7th Brigade Regional Academic, Air Rifle, Drill, and Robotics Competition in Fort Knox, KY on March 14, 2020. Jane Herron seconded the motion. On a voice vote, the motion was approved 7-0.

Vance Willis made a motion to approve a trip request for the HCHS JROTC to host a Resident Raider Training Camp at HCHS on July 30-August 2, 2020 for 12-15 students. Ron Gammons seconded the motion. On a voice vote, the motion was approved 7-0.

Ron Gammons made a motion to approve the HCHS JROTC request to host a military formal and awards banquet at HCHS on May 2, 2020. Jim Hudgins seconded the motion. On a voice vote, the motion was approved 7-0.

Steve Gianakos made a motion to approve budget amendments 6, 7, and 8. Jim Hudgins seconded the motion.

<u>Aye</u>	<u>Nay</u>	<u>Pass</u>	<u>Absent</u>
Amy Bryant			
Ron Gammons			
Steve Gianakos			
Jane Herron			
Tim Hobbs			
Jim Hudgins			
Vance Willis			

On a roll call vote, the motion was approved 7-0.

Vance Willis made a motion to approve the purchase of 6 Type C 78-passenger buses and 1 Type C 39-passenger bus, all with propane and seat belts options. Jim Hudgins seconded the motion.

<u>Aye</u>	<u>Nay</u>	<u>Pass</u>	<u>Absent</u>
Amy Bryant			
Ron Gammons			
Steve Gianakos			
Jane Herron			
Tim Hobbs			
Jim Hudgins			
Vance Willis			

On a roll call vote, the motion was approved 7-0.

Ron Gammons made a motion to approve the bus engine replacement to Underwood Tire at a cost of \$17,000.00. Steve Gianakos seconded the motion.

<u>Aye</u>	<u>Nay</u>	<u>Pass</u>	<u>Absent</u>
Amy Bryant			
Ron Gammons			
Steve Gianakos			
Jane Herron			
Tim Hobbs			
Jim Hudgins			
Vance Willis			

On a roll call vote, the motion was approved 7-0.

Vance Willis made a motion to approve the Job Share request for 2nd grade at East Hickman Elementary School. Ron Gammons seconded the motion. On a voice vote, the motion was approved 7-0.

Jim Hudgins made a motion to provide the Director of Schools authority to negotiate and make an offer on the land behind Hickman County Middle School up to \$20,000.00. Ron Gammons seconded the motion.

<u>Aye</u>	<u>Nay</u>	<u>Pass</u>	<u>Absent</u>
------------	------------	-------------	---------------

Amy Bryant			
Ron Gammons			
Steve Gianakos			
Jane Herron			
Tim Hobbs			
Jim Hudgins			
Vance Willis			

On a roll call vote, the motion was approved 7-0.

Vance Willis made a motion to approve revised board policies 6.312 and 6.300 with the revision in 6.300 to say Principal Discretion for the Cell Phone Violation section. Jim Hudgins seconded the motion. On a voice vote, the motion was approved 7-0.

Steve Gianakos made a motion to approve the review of board policies 4.100-4.211. Ron Gammons seconded the motion. On a voice vote, the motion was approved 7-0.

Chair Amy Bryant announced that the board retreat date scheduled for February 8, 2020, had been cancelled.

The meeting was adjourned at 7:36 p.m.
On a voice vote, the motion was approved 7-0.

Ron Gammons made a motion to add amend item VI. A.7. to add Cosmetology Trip Request. Jim Hudgins seconded the motion. On a voice vote, the motion was approved 7-0.

Vance Willis made a motion to approve the amended agenda. Jim Hudgins seconded the motion.

The Hickman County Board of Education will meet in regular session on Monday, February 3, 2020, at 7:00 p.m. in Room 203 at the Central Office. A work session will be held at 6:00 p.m. in Room 203 of the Central Office.

- I. Call to Order
- II. Approval of January 6, 2020 Regular Board Meeting Minutes
- III. Approval of Agenda
- IV. Special Recognition
 - A. Employee of the Month (Vance Willis)
- V. Communications to the Board
 - A. Director's Report--Director of Schools
 - B. Financial Report--Business Officer

- C. OPEB Trust Financial Statement--Director of Schools
- VI. Items Requiring Board Action
 - A. Trip Requests--Sponsor and Students
 - 1. East Hickman High School FFA--Sponsor and Students
 - 2. Hickman County High School Girls Soccer--Coach and Players
 - 3. Hickman County High School JROTC--Sponsor and Students
 - 4. Hickman County High School JROTC--Sponsor and Students
 - 5. Hickman County High School JROTC--Sponsor and Students
 - 6. Hickman County High School JROTC--Sponsor and Students
 - 7. EHHS/HCHS Cosmetology--Sponsor and Students
 - B. Hickman County High School JROTC Military Formal--Sponsor and Students
 - C. Budget Amendments--Business Officer
 - D. School Bus Bids--Director of Transportation
 - E. Engine Replacement Proposal--Director of Transportation
 - F. EHES Job Share Request--Principal and Supervisor
 - G. Land for Sale behind HCMS--Director of Schools
 - H. Revised Board Policies 6.300, 6.312 (2nd Reading)--Director of Accountability
 - I. Board Policy Review 4.100-4.211--Director of Accountability
- VII. Announcements--Board Retreat scheduled for February 8, 2020 has been cancelled
- VIII. Adjourn

On a voice vote, the motion was approved 7-0.

Ron Gammons recognized the maintenance team of James Atkinson, Bill Lynch, Barry Talley, and Toby Warren as Employees of the Month.

Amy Bryant recognized the students that competed in state-level competitions in athletics.

Ron Gammons made a motion to accept the Director's Report. Jim Hudgins seconded the motion.

Memorandum

To: Board Members
 From: Michelle Gilbert
 Date: January 28, 2020
 RE: February Director's Report

Leave of Absence

Professional

Robyn Emerson
 Kim Jenkins

FMLA (January 6-February 10, 2020)
 FMLA (January 6-February 10, 2020)

Support Staff

Hiring

Professional

Christy Uhl
 Jennifer Armstrong
 Ashley Easley
 Lonnie Horner

Project AWARE Student Support
 Project AWARE Student Support
 Project AWARE Student Support
 HCHS Biology (100-day contract)

Support Staff

Tracy Rivers
 Sarah Eisenhuth
 Horace Dunnivant

HCHS In-School Suspension
 HCMS Special Education Assistant
 Substitute Bus Driver

Resignation

Professional

Support Staff

Stephanie Bodine

EHES Special Education Assistant

Retirement

Professional

Support Staff

Transfers

Professional

Support Staff

Floy Ann McCutchen

Substitute Bus Driver to Full Time Bus Driver

Jessie Waters

Substitute Bus Driver to Full Time Bus Driver

Ronnie Lewis

Substitute Bus Driver to Full Time Bus Driver

Appointment

Professional

Support Staff

Brett Lovett

HCHS Interim Head Football Coach

Open Positions

1 Music Position

1 School Counselor Position

1 Secondary Math Position

2 Special Education Positions

1 Bookkeeper Position

1 Special Education Assistant

On a voice vote, the motion was approved 7-0.

Vance Willis made a motion to accept the financial report. Jim Hudgins seconded the motion.

On a voice vote, the motion was approved 7-0.

A presentation was made to the school board regarding the expansion of the EPSO program at the high school level.

Vance Willis made a motion to accept the Director of School Evaluation Appendix C. Jane Herron seconded the motion. On a voice vote, the motion was approved 7-0.

Ron Gammons made a motion to approve the overnight trip request for HCHS HOSA to attend the state leadership conference at Opryland Hotel on April 6-9, 2020. Jim Hudgins seconded the motion. On a voice vote, the motion was approved 7-0.

Ron Gammons made a motion to approve the overnight trip request for HCHS FFA to attend state convention in Gatlinburg, TN, on March 29-April 1, 2020. Tim Hobbs seconded the motion. On a voice vote, the motion was approved 7-0.

Jane Herron made a motion to approve the overnight trip request for EHHS FBLA to attend state convention in Chattanooga, TN, on April 5-8, 2020. Tim Hobbs seconded the motion. On a voice vote, the motion was approved 7-0.

Ron Gammons made a motion to approve the overnight trip request for EHHS FCCLA to attend state competition in Chattanooga, TN, on March 25-27, 2020. Vance Willis seconded the motion. On a voice vote, the motion was approved 7-0.

Ron Gammons made a motion to approve the overnight trip request for EHHS HOSA to attend state convention in Nashville, TN, on April 7-9, 2020. Jim Hudgins seconded the motion. On a voice vote, the motion was approved 7-0.

Ron Gammons made a motion to approve the overnight trip request for EHHS/HCHS Cosmetology state convention and competition in Chattanooga, TN, on April 19-22, 2020. Tim Hobbs seconded the motion. On a voice vote, the motion was approved 7-0.

Ron Gammons made a motion to approve the request to host an in-school soccer game between HCHS and EHHS at East Hickman High School on March 20, 2020, at 1:00 p.m. Steve Gianakos seconded the motion. On a voice vote, the motion was approved 7-0.

Jim Hudgins made a motion to approve Budget Amendments #9, #10, and #11. Vance Willis seconded the motion.

<u>Aye</u>	<u>Nay</u>	<u>Pass</u>	<u>Absent</u>
Amy Bryant			
Ron Gammons			
Steve Gianakos			
Jane Herron			
Tim Hobbs			
Jim Hudgins			
Vance Willis			

On a roll call vote, the motion was approved 7-0.

Jim Hudgins made a motion to approve the amended fund balance to reflect \$8,800,863.00 as of the end of the 2018-2019 fiscal year. Amy Bryant seconded the motion.

<u>Aye</u>	<u>Nay</u>	<u>Pass</u>	<u>Absent</u>
Amy Bryant			
Ron Gammons			
Steve Gianakos			
Jane Herron			
Tim Hobbs			
Jim Hudgins			
Vance Willis			

On a roll call vote, the motion was approved 7-0.

Tim Hobbs made a motion to keep the attendance zones for the 2019-2020 school year the same as originally drawn for the 2007-2008 school year. Ron Gammons seconded the motion. On a voice vote, the motion was approved 7-0.

Vance Willis made a motion to approve the purchase of 300 Chromebooks at \$249.00/device for a total of \$74,700.00. Jim Hudgins seconded the motion.

<u>Aye</u>	<u>Nay</u>	<u>Pass</u>	<u>Absent</u>
Amy Bryant			
Ron Gammons			
Steve Gianakos			
Jane Herron			
Tim Hobbs			
Jim Hudgins			
Vance Willis			

On a roll call vote, the motion was approved 7-0.

Jim Hudgins made a motion to purchase ERate equipment from Central Technologies pending USAC and local funding in the 2020-2021 year.

<u>Aye</u>	<u>Nay</u>	<u>Pass</u>	<u>Absent</u>
Amy Bryant			
Ron Gammons			
Steve Gianakos			
Jane Herron			
Tim Hobbs			
Jim Hudgins			
Vance Willis			

On a roll call vote, the motion was approved 7-0.

Ron Gammons made a motion to purchase computers for \$9,800.00 and \$2,300.00 for monitors from Systems Liquidations. Jim Hudgins seconded the motion.

<u>Aye</u>	<u>Nay</u>	<u>Pass</u>	<u>Absent</u>
Amy Bryant			
Ron Gammons			
Steve Gianakos			
Jane Herron			
Tim Hobbs			
Jim Hudgins			
Vance Willis			

On a roll call vote, the motion was approved 7-0.

Amy Bryant made a motion to approve the ENA Internet Services contract for 5 years. Tim Hobbs seconded the motion.

<u>Aye</u>	<u>Nay</u>	<u>Pass</u>	<u>Absent</u>
Amy Bryant			
Ron Gammons			
Steve Gianakos			
Jane Herron			

Tim Hobbs
Jim Hudgins
Vance Willis

On a roll call vote, the motion was approved 7-0.

Amy Bryant made a motion to approve the job requests at Centerville Intermediate School for the 2020-2021 school year. Vance Willis seconded the motion. On a voice vote, the motion was approved 7-0.

Vance Willis made a motion to extend the Board of Education offer on the land behind HCMS for an additional 90 days. Jim Hudgins seconded the motion.

<u>Aye</u>	<u>Nay</u>	<u>Pass</u>	<u>Absent</u>
------------	------------	-------------	---------------

Amy Bryant			
Ron Gammons			
Steve Gianakos			
Jane Herron			
Tim Hobbs			
Jim Hudgins			
Vance Willis			

On a roll call vote, the motion was approved 7-0.

Vance Willis made a motion to approve revised board policies 4.2013, 3.204, 4.302, 4.606 on first reading. Jane Herron seconded the motion. On a voice vote, the motion was approved 7-0.

Amy Bryant made a motion to approve the review and update of board policies 4.300-4.407. Vance Willis seconded the motion. On a voice vote, the motion was approved 7-0.

Amy Bryant announced the April Board meeting would be held at East Hickman High School, and the May Board meeting would be held at Hickman County High School.

The meeting was adjourned at 7:52 p.m.



AMY BRYANT
9589 S Lick Creek Rd., Lyles, TN 37098

RONALD GAMMONS
6419 Rice Ln., Lyles, TN 37098

TIM HOBBS
9220 Old Bon Aqua Rd., Bon Aqua, TN 37025

JIM HUDGINS
1297 E. Grinders Switch Rd., Centerville, TN 37033

JANE HERRON
1222 Hwy. 100., Centerville, TN 37033

STEVE GIANAKOS
9792 Dogwood Dr., Bon Aqua, TN 37025

VANCE WILLIS
2868 Hwy 48 N., Nunnely, TN 37137

Michelle Gilbert
Director of Schools
115 MURPHREE AVENUE
CENTERVILLE, TN 37033

The Hickman County Board of Education will meet in regular session on Monday, May 4, 2020, at 7:00 p.m. in Room 203 at the Central Office. A work session will be held at 6:00 p.m. in Room 203 of the Central Office.

- I. Call to Order
- II. Approval of March 2, 2020 Regular Board Meeting Minutes
- III. Approval of Agenda
- IV. Communications to the Board
 - A. Director's Report--Director of Schools
 - B. Financial Report--Business Officer
 - C. TSBA OPEB Quarterly Investment Report--Director of Schools
 - D. Land for Sale Behind HCMS--Director of Schools
- V. Items Requiring Board Action
 - A. Budget Amendments--Business Officer
 - B. Textbook Adoption--Deputy Superintendent of Schools
 - C. Resolution 20-01--Director of Schools
 - D. Resolution 20-02--Board Chair
 - E. Resolution 20-03--Board Chair
 - F. ATSI Technology Purchase--Director of Schools
 - G. Maintenance Tractor Equipment--Maintenance Director
 - H. School Painting Services--Maintenance Director
 - I. HVAC Services and Repair--Maintenance Director
 - J. Security Doors at HCHS--Maintenance Director
 - K. Concrete Work Services--Maintenance Director
 - L. School Security Cameras--Technology Director
 - M. 2020-2021 141, 142, 143 School Budgets--Director of Schools
 - N. Addition of Board Policies 1.8011, 5.1151, 5.3051 (1st Reading-Waive 2nd Reading)--Director of Accountability
 - O. Grading Procedures--Director of Schools
 - P. Supplemental Pay for COVID 19 Services--Director of Schools
 - Q. Virtual School--Director of Schools
 - R. EHMS Gym Floor-Director of Schools
 - S. Declaration of Surplus--Director of Schools
 - T. Revised Board Policies 4.2013, 3.204, 4.302, 4.606 (2nd Reading)--Director of Accountability

U. Board Policy Review 4.408-4.607--Director of Accountability

VI. Announcements

A. Special Called May Board Meeting

VII. Adjourn



AMY BRYANT
9589 S. Lick Creek Rd., Lyles, TN 37098

RONALD GAMMONS
6419 Rice Ln., Lyles, TN 37098

TIM HOBBS
9220 Old Bon Aqua Rd., Bon Aqua, TN 37025

JIM HUDGINS
1297 E. Grinders Switch Rd., Centerville, TN 37033

JANE HERRON
1222 Hwy. 100., Centerville, TN 37033

STEVE GIANAKOS
9792 Dogwood Dr., Bon Aqua, TN 37025

VANCE WILLIS
2868 Hwy 48 N., Nunnally, TN 37137

Michelle Gilbert
Director of Schools
115 MURPHREE AVENUE
CENTERVILLE, TN 37033

Memorandum

To: Board Members
From: Michelle Gilbert
Date: April 24, 2020
RE: May Director's Report

Leave of Absence

Professional

Mindy James

July 29, 2020-May 20, 2020

Support Staff

Hiring

Professional

Support Staff

Resignation

Professional

Keri Hanes
Michael Harrison

EHES Intervention
HCHS Math

Support Staff

Retirement

Professional

Support Staff

Transfers

Professional

Support Staff

Appointment

Professional

Support Staff

Open Positions

- 1 Music Position
- 1 School Counselor Position
- 2 Secondary Math Position
- 2 Special Education Positions
- 1 Bookkeeper Position
- 1 Special Education Assistant
- 1 Student Support Project AWARE

Account Activity Summary
Hickman
01/01/2020 - 03/31/2020

Beginning Value ¹ See Definitions	\$	2,326,385.00
Additions ²		
Contributions ³	\$	-
Dividends & Interest ⁴	\$	7,923.44
Withdrawals ⁵		
TSBA Fee ⁶	\$	(1,453.99)
MS Fees ⁷	\$	(990.89)
System Distributions ⁸	\$	-
Unadjusted Investment Earnings ⁹	\$	(384,046.55)
Ending Value ¹⁰	\$	1,947,817.01

Definitions:

1. **Beginning Value:** The total account value at the start of business on the first day of the specified reporting period.
2. **Additions:** All credits to the account in which total account value is increased within the specified reporting period.
3. **Contributions:** The sum of total cash deposits and/or other asset transfers into the Morgan Stanley account from outside of the Morgan Stanley account and by instruction of the client within the specified reporting period.
4. **Dividends and Interest:** The sum of all dividend, interest, and capital gain payments credited to the account and those in the which settlement date lies within the specified reporting period. **NOTE:** Any dividend, interest, or capital gain distribution in which a settlement date lies outside of the reporting period or in which was included in the beginning value will not be included 'Dividends and Interest' total for the period.
5. **Withdrawals:** The sum of total cash and/or other asset transfers out of the Morgan Stanley account to any other account whether inside or outside of the firm.
6. **TSBA Fee:** The fee calculated by instruction of the client and is based on the account value at the end of business on the last day of the prior quarter.
7. **MS Fees:** The sum of all quarterly fees charged by Morgan Stanley and any adjustments made to this charge within the specified reporting period in which client is in agreement for investment advisory and brokerage services provided.
8. **System Distributions:** The sum of any distributions to the beneficiary (public school system) of the GASB 45 Trust within the specified reporting period.
9. **Unadjusted Investment Earnings:** The earnings of asset investments in the Morgan Stanley account unadjusted for any fees charged or withdrawals in the account by instruction of Morgan Stanley or the client and within the specified reporting period.
10. **Ending Value:** The Account Value at the end of business on the last day of the specified reporting period.

The information and data contained in this report are from sources considered reliable, but their accuracy and completeness is not guaranteed. This report has been prepared for illustrative purposes only and is not intended to be used as a substitute for monthly transaction statements you receive on a regular basis from Morgan Stanley Smith Barney LLC. Please compare the data on this document carefully with your monthly statements to verify its accuracy. The Company strongly encourages you to consult with your own accountants or other advisors with respect to any tax questions.

Account Contribution Summary
Hickman
01/01/2020 - 03/31/2020

ACTIVITY DATE	ACTIVITY	DESCRIPTION		TYPE
		Total Deposits	0.00	

The information and data contained in this report are from sources considered reliable, but their accuracy and completeness is not guaranteed. This report has been prepared for illustrative purposes only and is not intended to be used as a substitute for monthly transaction statements you receive on a regular basis from Morgan Stanley Smith Barney LLC. Please compare the data on this document carefully with your monthly statements to verify its accuracy. The Company strongly encourages you to consult with your own accountants or other advisors with respect to any tax questions.

Account Dividend & Interest Summary
Hickman
01/01/2020 - 03/31/2020

ACTIVITY DATE	ACTIVITY	DESCRIPTION		TYPE
01/02/2020	Dividend	PGIM SHORT-TERM CORP BOND Z Ref: 00280265 SEC ID: MQR42	667.91	Cash
01/02/2020	Dividend	PIONEER BOND Y Ref: 00238288 SEC ID: MC336	403.26	Cash
01/02/2020	Dividend	NUVEEN STRATEGIC INCOME INST Ref: 00297134 SEC ID: MB170	439.06	Cash
01/02/2020	Dividend	PUTNAM FLOATING RATE INC Y Ref: 00242450 SEC ID: MAU65	239.88	Cash
01/02/2020	Dividend	E V SHT DURATION GOVT INC I Ref: 00222226 SEC ID: AS79A	61.86	Cash
01/31/2020	Interest Income	MORGAN STANLEY BANK N.A. (Period 01/01-01/31) Ref: 03149648 SEC ID: 00361	5.74	Cash
02/03/2020	Dividend	PGIM SHORT-TERM CORP BOND Z DIV PAYMENT Ref: 03474923 SEC ID: MQR42	862.38	Cash
02/03/2020	Dividend	PIONEER BOND Y DIV PAYMENT Ref: 03414268 SEC ID: MC336	428.16	Cash
02/03/2020	Dividend	NUVEEN STRATEGIC INCOME INST DIV PAYMENT Ref: 03475690 SEC ID: MB170	446.05	Cash
02/03/2020	Dividend	PUTNAM FLOATING RATE INC Y DIV PAYMENT Ref: 03431644 SEC ID: MAU65	237.66	Cash
02/12/2020	Dividend	THORNBURG INTL GROWTH I DIV PAYMENT Ref: 04365934 SEC ID: MC949	342.56	Cash
02/12/2020	Dividend - Adjustment	THORNBURG INTL GROWTH I DIV ADJUSTMENT Ref: 04365936 SEC ID: MC949	-298.93	Cash
02/28/2020	Interest Income	MORGAN STANLEY PRIVATE BANK NA (Period 02/24-02/29) Ref: 05962190 SEC ID: 00368	3.35	Cash
02/28/2020	Interest Income	MORGAN STANLEY BANK N.A. (Period 02/01-02/29) Ref: 05968433 SEC ID: 00361	7.24	Cash
03/02/2020	Dividend	PGIM SHORT-TERM CORP BOND Z DIV PAYMENT Ref: 06246548 SEC ID: MQR42	802.44	Cash
03/02/2020	Dividend	PIONEER BOND Y DIV PAYMENT Ref: 06280203 SEC ID: MC336	410.64	Cash
03/02/2020	Dividend	NUVEEN STRATEGIC INCOME INST DIV PAYMENT Ref: 06241565 SEC ID: MB170	422.85	Cash
03/02/2020	Dividend	PUTNAM FLOATING RATE INC Y DIV PAYMENT Ref: 06201697 SEC ID: MAU65	234.26	Cash

03/13/2020	Dividend	VANGUARD INDEX FDS S&P 500 ETF Ref: 07383125 SEC ID: D5A6U	359.29	Cash
03/26/2020	Dividend	VANGUARD FTSE EMERGING MARKETS Ref: 08641549 SEC ID: AYW20	30.21	Cash
03/27/2020	Dividend	PUTNAM EQUITY INCOME Y DIV PAYMENT Ref: 08765555 SEC ID: MVC69	214.30	Cash
03/31/2020	Dividend	ISHARES SP SMALLCAP 600 INDEX Ref: 09162939 SEC ID: AKA03	80.35	Cash
03/31/2020	Dividend	ISHARES S&P MIDCAP 400 INDEX Ref: 09116467 SEC ID: AJZ91	99.31	Cash
03/31/2020	Dividend	ISHARES CORE S&P U.S. GROWTH Ref: 09181070 SEC ID: ABZ64	484.90	Cash
03/31/2020	Dividend	ISHARES CORE S&P U.S. VALUE Ref: 09169181 SEC ID: ABZ53	934.65	Cash
03/31/2020	Interest Income	MORGAN STANLEY PRIVATE BANK NA (Period 03/01-03/31) Ref: 09119524 SEC ID: 00368	1.94	Cash
03/31/2020	Interest Income	MORGAN STANLEY BANK N.A. (Period 03/01-03/31) Ref: 09125342 SEC ID: 00361	2.12	Cash
		Total Dividends and Interest	7,923.44	

The information and data contained in this report are from sources considered reliable, but their accuracy and completeness is not guaranteed. This report has been prepared for illustrative purposes only and is not intended to be used as a substitute for monthly transaction statements you receive on a regular basis from Morgan Stanley Smith Barney LLC. Please compare the data on this document carefully with your monthly statements to verify its accuracy. The Company strongly encourages you to consult with your own accountants or other advisors with respect to any tax questions.

Account Fee Summary
Hickman
01/01/2020 - 03/31/2020

ACTIVITY DATE	ACTIVITY	DESCRIPTION		TYPE
01/06/2020	CASH TRANSFER	FUNDS TRANSFERRED CONFIRMATION # 123570770 TO 471-071947 Ref: 00670770	-1,453.99	Cash
01/08/2020	Service Fee	ADV FEE 01/01-01/31 Ref: 00836495	-351.42	Cash
01/17/2020	Service Fee Adj	NET PLATFORM CREDIT PLATFORM FEE (\$232.39) PLATFORM CREDIT \$235.10 Ref: 01798392	2.71	Cash
02/07/2020	Service Fee	ADV FEE 02/01-02/29 Ref: 03826627	-326.54	Cash
03/06/2020	Service Fee	ADV FEE 03/01-03/31 Ref: 06677725	-315.64	Cash
		Total Withdrawals	-2,444.88	

*Cash Balance Includes Cash, Bank Deposits, MMF Balance, and Unsettled Cash.

Unless otherwise indicated, this information is not intended to be a substitute for the official account statements that you receive from us. This information is approximate and subject to adjustment, updating and correction and is for illustrative and general reference purposes only. We are not responsible for any clerical, computational or other inaccuracies, errors or omissions. We obtain market values and other data from various standard quotation services and other sources, which we believe to be reliable. However, we do not warrant or guarantee the accuracy or completeness of any such information. The values that you actually receive in the market for any investment may be higher or lower than the values reflected herein. To the extent there are any discrepancies between your official account statement and this information, you should rely on the official account statement. This information should not be considered as the sole basis for any investment decision. The Bank Deposit Program (BDP) is a cash sweep feature whereby clients can chose to have their available free credit balances automatically deposited into interest bearing, FDIC-insured deposit accounts at up to three banks ("Program Banks"): (1) Morgan Stanley Bank, N.A. and/or Morgan Stanley Private Bank, National Association (together, the "Morgan Stanley Banks"), or (2) Citibank, N.A. The Program Banks are FDIC members. Morgan Stanley Smith Barney LLC ("Morgan Stanley") is a registered broker-dealer, not a bank. Morgan Stanley and the Morgan Stanley Banks are affiliates. Unless specifically disclosed to you in writing, other investments and services offered to you through Morgan Stanley are not insured by the FDIC, are not deposits of or other obligations of, or guaranteed by, the Program Banks and involve investment risks, including possible loss of principal amount invested. External Assets - Certain assets listed in this view are based upon information provided by you, your client or other external sources and are not part of accounts that you manage at Morgan Stanley. Assets not held with Morgan Stanley may not be covered by SIPC protection or by additional protection under Morgan Stanley's excess insurance coverage plans. Morgan Stanley may include information about these external assets in this view solely as a service to you, and Morgan Stanley is not responsible for the accuracy of any information provided by external sources, including but not limited to, you, your client or another financial institution. You are responsible for ensuring the accuracy of such information. Generally, any financial institution that holds securities is responsible for year-end reporting (Internal Revenue Service (IRS) Form 1099) and separate periodic statements, which may vary from Morgan Stanley's information due to different tax reporting periods.

The information and data contained in this report are from sources considered reliable, but their accuracy and completeness is not guaranteed. This report has been prepared for illustrative purposes only and is not intended to be used as a substitute for monthly transaction statements you receive on a regular basis from Morgan Stanley Smith Barney LLC. Please compare the data on this document carefully with your monthly statements to verify its accuracy. The Company strongly encourages you to consult with your own accountants or other advisors with respect to any tax questions.

Hickman County Board of Education
 Budget Amendment 12
 Fund 141 - General Purpose
 May 4, 2020

Account	Description	Debit	Credit	Justification
73400 - 355 -	Travel	\$ 180.42		
73400 - 399 -	Other Contracted Services	1,640.00		
73400 - 524 -	Inservice	24.54		Adjustment to PreK
73400 - 429 -	Instructional Supplies		\$ 1,348.74	
73400 - 790 -	Other Equipment		496.22	
73300 - 201 -	Social Security	2,409.75		
73300 - 201 - FRC	Social Security		1,204.88	Recording Expenditures in proper Cost Center
73300 - 201 - FRE	Social Security		1,204.87	
TOTALS		<u>\$ 4,254.71</u>	<u>\$ 4,254.71</u>	

Approved:

Attest:

Amy Bryant

Michelle Gilbert

Hickman County Board of Education
 Budget Amendment 13
 Fund 142 - Federal Programs
 May 4, 2020

Account	Description	Debit	Credit	Justification
71300 - 399 - - 801	Other Contracted Services	\$ 1,175.00		
71300 - 163 - - 801	Educational Assistants		\$ 250.00	
71300 - 499 - - 801	Other Supplies & Materials		3,916.30	Adjustments to CTE Perkins
71300 - 730 - - 801	Vocational Instruction Equipment		7,299.88	
72130 - 355 - C - 801	Travel	10,500.00		
72130 - 524 - PD - 801	Inservice		208.82	
72130 - 355 - - 101	Travel		2,000.00	To Bring budget into agreement with Title I ePlan budget
72710 - 189 - - 101	Other Salaries & Wages		1,000.00	
72710 - 201 - - 101	Social Security		76.50	
72710 - 204 - - 101	State Retirement		137.60	
72710 - 599 - - 101	Other Charges	3,214.10		
TOTALS		\$ 14,889.10	\$ 14,889.10	

Approved:

Attest:

Amy Bryant

Michelle Gilbert

The English Language Arts textbook committee was composed of representatives from each school. During the English Language Arts textbook adoption, each school researched, analyzed, and utilized the adoption resources in the classrooms. Each of the choices for English Language Arts adoption have been posted online since March 16 for review by the public. The textbook committees have recommended the following for English Language Arts adoption:

Grades K-3: McGraw Hill Wonders

Grades 4-5: Wit and Wisdom

Grades 6-12: Pearson

Each of these recommendations is currently on the state approved list for adoption.

Resolution – Emergency Suspension of Board Policies

BOARD RESOLUTION No. _____ 20-01 _____

WHEREAS, TCA 49-2-203 authorizes local boards of education to govern their respective districts, including adopting, revising, and suspending local board policies;

WHEREAS, on April 2, 2020, Governor Bill Lee signed Public Chapter 652 which removed the requirement for TCAP testing and allowed the State Board of Education to promulgate necessary rules to address issues created by COVID-19 in the 2019-2020 school year;

WHEREAS, on April 9, 2020, the State Board of Education revised several rules and policies in response to COVID-19 effective only for the 2019-2020 school year;

WHEREAS, changes made by the State Board of Education conflict with certain current local board policies;

NOW, THEREFORE BE IT RESOLVED, that the _____ Board of Education hereby suspends the following policies or provisions of its policies for the remainder of the 2019-2020 school year, including but not limited to those identified below, to the extent that they conflict with Public Chapter 652 or State Board of Education policies or rules and regulations for the 2019-2020 school year:

- 1) Policy 4.600 – Grading System
 - a) Students taking courses for high school credit shall receive no grade lower than the grade they earned in the course as of March 20, 2020. Additionally, Students taking post-secondary courses are not required to participate in the associated exam in order to receive GPA weighting for Spring 2020.
- 2) Policy 4.605 – Graduation Requirements
 - a) For the class of 2020, graduation requirements are modified as follows:
 - b) Only 20 credits are required to graduate per State Board Education Rule 0520-01-03-.11;
 - c) The requirements for the following are waived:
 - i) ACT/SAT
 - ii) Civics exam
 - iii) EOC exams
 - d) Students scheduled to receive an occupational diploma in the 2019-2020 or 2020-2021 school year shall only be required to demonstrate one year of work experience.

- 3) Policy 4.700 – Testing Program
 - a) [Choose this option if your board **WANTS** to require students to take TCAP exams]
 - i) Students shall take TCAP exams in the spring semester. These grades shall not become a portion of seniors’ final grades.
 - b) [Choose this option if your board **DOES NOT WANT** to require students to take TCAP exams]
 - i) Students shall not be required to take TCAP exams for the spring 2020 semester.
- 4) Policy 5.109 – Evaluation
 - a) Level of overall effectiveness scores shall not be generated for educators in the 2019-2020 school year.
 - b) Pre-kindergarten and kindergarten teachers shall not be evaluated using the growth portfolio model for the 2019-2020 school year.
 - c) Any observations required by State Board of Education Policy 5.201 that were not completed during the 2019-2020 school year as a result of COVID-19 are not required.
 - d) No student data from this year shall be allowed to negatively impact a teacher.
- 5) Policy 5.802 – Qualifications and Duties of the Director of Schools
 - a) The Director of Schools may request an extension from the State Board of Education to report information that would impact educator licensure (e.g. alleged employee misconduct, discipline of employees for actions that violate the teacher code of ethics, etc.).
- 6) Policy 6.200 – Attendance
 - a) Students may not be penalized for non-attendance of online courses.
 - b) Non-attendance of online courses shall not count as unexcused absences and shall not be recorded. Further, students shall not be counted truant for failure to attend online courses.

BE IT FURTHER RESOLVED that the Director of Schools shall consult with the Board as feasible and appropriate and shall timely report to the Board regarding implementation of board policies in alignment with Public Chapter 652 and updated State Board Policies and Rules and Regulations.

BE IT FURTHER RESOLVED that the Director of Schools will consult with the Board if he/she determines that additional policies or provisions of policies not contained in this resolution are found to conflict with current State Board rules or policies.

BE IT FURTHER RESOLVED that the Director of Schools may apply for any waiver or extension that ensures consistency with this resolution, board policies, and Public Chapter 652 or the State Board of Education policies or rules and regulations implemented to effectuate Public Chapter 652.

BE IT FURTHER RESOLVED that the Director of Schools shall inform the Board of any waiver or extension request made pursuant to this resolution.

BE IT FURTHER RESOLVED that execution of this Resolution is conclusive evidence of the Board's approval of this action and of the authority granted herein.

Adopted and approved this _____ day of _____.

By: _____
Board Chair

Attest: _____
Director of Schools

**Resolution 20-02 to Recognize Hickman County School System Employees during
COVID-19 Pandemic**

Whereas the COVID-19 pandemic greatly impacted the education system and life in Hickman County;

Whereas Governor Lee recommended on March 16 that schools be closed until April 24 and later recommended that schools be closed for the remainder of the school year;

Whereas Tennessee was placed under a safer-at-home order by Governor Lee;

Whereas Hickman County declared a local state of emergency during April 2020;

Whereas the Hickman County School System complied with Governor Lee's recommendations and closed schools;

Whereas administrators and teachers in the Hickman County School System continued to provide educational packets and opportunities to students in all grade levels;

Whereas the Hickman County School System's School Nutrition employees implemented a plan to provide two meals a day to children under the age of 18 in Hickman County;

Whereas employees of the Hickman County School System created and provided thousands of meals to children of Hickman County during the last half of March and April;

Whereas the Hickman County School System provided meal pick-up locations throughout the county to make the meals more readily available to families;

Whereas employees of the Hickman County School System continued to fulfill the mission of the school system during a national, state, and local emergency;

Whereas employees of the Hickman County School System provided exceptional physical, mental, educational, and emotional support to Hickman County;

Now, therefore be it resolved that the Hickman County Board of Education does hereby recognize all employees of the Hickman County School System for their service, spirit, and dedication during the COVID-19 emergency.

Date:

Vote to adopt:

Chair of Hickman County Board of Education

Resolution 20-03 to Recognize Brian Buttrey's Volunteerism and Support of Hickman County's Children and Families during COVID-19 Pandemic

Whereas the COVID-19 pandemic greatly impacted the education system and life in Hickman County;

Whereas Governor Lee recommended on March 16 that schools be closed until April 24 and later recommended that schools be closed for the remainder of the school year;

Whereas Tennessee was placed under a safer-at-home order by Governor Lee;

Whereas Hickman County declared a local state of emergency during April 2020;

Whereas the Hickman County School System complied with Governor Lee's recommendations and closed schools;

Whereas the Hickman County School System implemented a plan to provide two meals a day to children under the age of 18 in Hickman County;

Whereas employees of the Hickman County School System created and provided thousands of meals to children of Hickman County during the last half of March and April;

Whereas the Hickman County School System provided meal pick-up locations throughout the county to make the meals more readily available to families;

Whereas Brian Buttrey, a member of the community, volunteered to deliver meals to families in Hickman County;

Whereas Brian Buttrey continued to volunteer and increased the number of deliveries daily during the first weeks of meal delivery;

Whereas Brian Buttrey volunteered to deliver 60 meals, the maximum amount that would fit in his vehicle, every day that meals were provided by Hickman County School System;

Now, therefore be it resolved that the Hickman County Board of Education does hereby recognize Brian Buttrey for his service, spirit, and dedication during the COVID-19 emergency and does hereby nominate Brian Buttrey for the Tennessee School Board Association's Volunteer Award.

Date:

Vote to adopt:

Chair of Hickman County Board of Education

Invitation to
Bid

The Hickman County Finance Office is accepting sealed bids for Chromebook Units and Chrome OS Management Service License.

Bid with specifications are online at: www.hickmank12.org/request-for-proposal.

Sealed bids must be mailed or delivered to the Hickman County Finance Office, 114 North Central Avenue, Suite 203, Centerville, TN 37033 and clearly marked on the outside of the envelope "Chromebooks and Chrome Management Licenses". Bids will be opened on Monday, February 10, 2020 at 10:00 a.m. in the Finance Office. The Hickman County Board of Education reserves the right to accept or reject any and all bids or parts of bids and to waive any informalities that would prevent the acceptance of a better bid.

BBC Unit price \$289.⁰⁰

Firefly \$242.⁰⁰
\$249.⁰⁰

V+S Technologies 148.⁹¹
218.⁰⁰

Present Penny Mayberry
Dorinda Dunn



**Hickman County Schools
Chromebook Bid**

**HP Chromebook 14 G5
Model: 3NU63UT#ABA**

Specifications:

Processor: Intel Celeron N3350 Dual-Core, 1.10GHz
RAM: 4GB
Hard Drive: 16GB Solid State
Wireless: IEEE 802.11ac, Bluetooth 4.2
Screen: 14" Active Matrix Color LED HD LCD, 1366 x 768
Color: Black (choice of Hickman Co. of availability)
Warranty: Limited 1 Year
Ports: USB, HDMI, and Headphone Jack

Included Software:

Google Chrome Management Console License
Education, 36-month Perpetual License (CROSSWDISEDU)

Total Unit Cost: \$289.00
(unit pricing includes shipping/freight)

Price Guaranteed until June 12th, 2020
Delivery within 18 days of order request is accepted during the entire bid term.



Services Included in Unit Pricing

- ✦ Any and all purchased Chromebooks will be delivered to your desired location/locations already configured and setup with your school's Google Domain.
- ✦ Should you have an Asset Tag inventory system and wish for us to place the Asset Tags on each machine we will inventory them into the Google Management Console for your convenience. We will assign them locations, asset tag numbers, and specified names for easy tracking and management. If you have multiple locations that you would like for us to accommodate during the inventory process that can be arranged as well.
- ✦ If you have corresponding storage carts for these Chromebooks, we will unbox and place each Chromebook in their desired carts as well as run and organize the charges inside the cart.

All Terms and Conditions are accepted as printed in the schools Invitation to Bid.

BGCS is a registered company, licensed to do business in Hickman, Co. TN with a valid Hickman Co. Business License. No subcontractors will be used.



**Services Included in
Unit Pricing/Notes to Bid**

ATTENTION:

Hickman Co. Schools

FROM:

**Bluegrass Computer Systems, LLC
174 Saundersville Road, Suite 503
Hendersonville, TN 37075**

SUBJECT: Chromebook Bid

Non-Technical Acknowledgements/ Notes

- 1) All Equipment is Brand New, Non- Refurbished
- 2) BGCSystems acknowledges that net 30 terms is to be extended for all purchases.
- 3) BGCSystems acknowledges that the school district is exempt of all sales taxes.
- 4) BGCSystems promises to provide delivery of all goods within 15 days of Purchase Order date. This statement is provided that all products are in manufacture "stock". Certain items may require longer periods of time for delivery. Estimates are available before purchase if requested.
- 5) All Orders will be delivered to the school location of choice FOB.
- 6) All pricing is guaranteed until June 12th, 2020.

- 7) BGCSystems has been in operation since 2010 and operates in multiple states and was awarded Ingram Micro's SMB Award as being the 12th fastest growing IT company in the nation for periods of 2012-2015. Proof of Financial and Business Capability is available per request.
- 8) BGCSystems will NOT subcontract in any way.
- 9) BGCSystems carries \$4,000,000 of General Liability Insurance and can provide proof if request.
- 10) BGCSystems maintains their corporate sales and service office in Hendersonville, TN.
- 11) BGCSystems has provided very competitive pricing that is based on reasonable quantity order as recorded by sales history to other districts that compare to the student population of the school district. However, additional discounts may be offered for additional quantities.
- 12) Length of Years in Business: 10 total years with direct focus of K-12 Education in the Missouri and Tennessee markets.
- 13) Warranty/Service Experience: School District. may request warranty service through our help desk at 888-423-0769, by emailing max@bgcsystems.com or by submitting a warranty ticket at the BGCSystems Online Client Portal. BGCSystems will work directly with the manufacture to provide warranty assistance. School District will NOT have to call manufacture directly for any type of support, however, a toll free support line to each manufacture will be made available to the district if the district wishes.

- 14) Vendor Help Desk: BGCSystems Help Desk is available from 8am to 5pm Monday- Friday at 888-423-0769. Additional time may be requested at no additional charge for after hour or weekend support. The BGCSystems Online Client Portal will be available to the district 24 hours a day, 7 days a week. The Client Portal will allow for warranty tickets to be created, help desk (general questions) tickets to be created and provide a custom knowledgebase of articles pertaining to products owned by the school district.
- 15) BGCSystems has provided detailed explanation of compliance of bid specification on this document, however in addition, BGCSystems provides a blanket compliance of all bid specifications as outlined in the bid packet.
- 16) BGCSystems agrees to purchase and secure and bid, performance, and/or payment bonds as requested by school district.
- 17) Please consider our services, listed below, that are included free of charge in each of our bid prices.



Services Included in Unit Pricing/Notes to Bid

Technical Acknowledgements/ Notes

Chromebooks- BGCSYSTEMS will providing the following services for Chromebook purchases

- a. "White Glove" service to include enrollment, asset tag placement, and Chromebook Management Sub Organization creation
- b. Warranty Support to allow the district to request service from BGCSYSTEMS directly for all warranty needs.
- c. Onsite Delivery, Installation, and trash removal provided by BGCSYSTEMS staff member.

Computer Systems (Desktops and Laptops) BGCSYSTEMS will providing the following services for Computer Systems purchases

- d. "White Glove" service to include domain join, asset tag placement, and full system imaging. System imaging to include imaging per direct specification of technology coordinator.
- e. Warranty Support to allow the district to request service from BGCSYSTEMS directly for all warranty needs.
- f. Onsite Delivery, Installation, and trash removal provided by BGCSYSTEMS staff member.



Education Client References

This is a list of several customers of Bluegrass Computer Systems, LLC. Please feel free to use these individuals should you seek personal and professional references on our behalf.

- Stewart County Schools
Dover, TN
Chris Guynn – (931) 232-5176
- Delta R-V Schools
Delta, MO
Scott Crabtree – (573) 794-2511
- Henry County Schools
Paris, TN
Denton Jordan – (731) 644-2521
- Charleston R-1 School District
Charleston, MO
Nate Burton - (573) 683-3776
- Humboldt City Schools
Humboldt, TN
Wayne Sheehan- (731) 414-8625



FireFly Computers
 1271 Red Fox Road
 Saint Paul, MN 55112
 fireflycomputers.com

Quote #: E000014605

Hickman County Schools Brad Gilbert 931-729-3391 brad.gilbert@hickmank12.org	Customer Number 70338	Quote Date 2/3/2020	Expiration Date 3/2/2020	Terms Net 30
--	---------------------------------	-------------------------------	------------------------------------	------------------------

Google Chrome Education Upgrade
 Pricing prior to March 2, 2020.

Ryan Lapadat
 Direct: 651-400-1042
 Fax: 612-392-2155
 Email: RLapadat@fireflycomputers.com

Quantity	Item	Unit Price	Extended Price
1	HP Chromebook 14A G5 - Rugged MIL-STD-810G Construction - 14" Anti-Glare HD Display (1366 x 768) - AMD A4-9120c Dual-Core - 4 GB DDR4 SDRAM - 16 GB eMMC Flash Memory - 2x USB-C, 2x USB 3.0 - Chrome OS - 1 Year Depot Warranty	212.00	212.00
1	Google Chrome Education Upgrade	24.00	24.00
1	FireFly White Glove Under 300 Units FireFly White Glove Under 300 Units - Preconfigured wireless access settings - Pre-enrolled in Google Apps® domain - Chrome OS® updates installed - Custom themes and settings applied - Hardware functionality check - Google Console OU management	6.00	6.00
1	FireFly Asset Tags with White Glove FireFly Asset Tags with White Glove	0.00	0.00
1	FF-SUPPORT-HP - Easy-to-use Online RMA Portal for Simplified Warranty Claim Submissions - FireFly SMART RMA Boxes for Convenient Bulk Warranty Returns and Bulk Paid Repairs - Unlimited Chromebook Technical Support by Phone or Email from Google-Certified Engineers - Access to FireFly Repair Zone Website for Easy Ordering of Chromebook Parts and Repairs - Complimentary Assistance Claiming Free Offers, when available	0.00	0.00



FireFly Computers
 1271 Red Fox Road
 Saint Paul, MN 55112
 fireflycomputers.com

Quote #: E000014605

Hickman County Schools Brad Gilbert 931-729-3391 brad.gilbert@hickmank12.org	Customer Number 70338	Quote Date 2/3/2020	Expiration Date 3/2/2020	Terms Net 30
--	--	--	---	-----------------------------------

Ryan Lapadat
 Direct: 651-400-1042
 Fax: 612-392-2155
 Email: RLapadat@fireflycomputers.com

Sale Amount: 242.00
Freight: 0.00
Sales Tax: 0.00

Total Amount: 242.00

Terms And Conditions:

Prices reflect a 3% discount for cash/check payment. Credit card payment is accepted without discount. This quote is confidential and is to be viewed solely by individuals within the organization to whom it is addressed. Unauthorized distribution or disclosure of the contents of this quote is prohibited. If you are not from the organization addressed, please notify us immediately so we can prepare a quote specific to you. Prices and availability may change without notice prior to the quote expiration date.

Ordering:

Please email purchase orders to orders@fireflycomputers.com or fax orders to 612-392-2155

Questions:

If you have any questions regarding this quote, please feel free to contact your FireFly Account Manager listed above at your convenience. We pride ourselves on providing you a quick response.



FireFly Computers
 1271 Red Fox Road
 Saint Paul, MN 55112
 fireflycomputers.com

Quote #: E000014610

Hickman County Schools
 Brad Gilbert
 931-729-3391
 brad.gilbert@hickmank12.org

Customer Number	Quote Date	Expiration Date	Terms
70338	2/3/2020	6/12/2020	Net 30

Ryan Lapadat
 Direct: 651-400-1042
 Fax: 612-392-2155
 Email: RLapadat@fireflycomputers.com

Google Chrome Education Upgrade
 Pricing after March 2, 2020

Quantity	Item	Unit Price	Extended Price
1	HP Chromebook 14A G5 - Rugged MIL-STD-810G Construction - 14" Anti-Glare HD Display (1366 x 768) - AMD A4-9120c Dual-Core - 4 GB DDR4 SDRAM - 16 GB eMMC Flash Memory - 2x USB-C, 2x USB 3.0 - Chrome OS - 1 Year Depot Warranty	212.00	212.00
1	Google Chrome Education Upgrade	31.00	31.00
1	FireFly White Glove Under 300 Units FireFly White Glove Under 300 Units - Preconfigured wireless access settings - Pre-enrolled in Google Apps@ domain - Chrome OS@ updates installed - Custom themes and settings applied - Hardware functionality check - Google Console OU management	6.00	6.00
1	FireFly Asset Tags with White Glove FireFly Asset Tags with White Glove	0.00	0.00
1	FF-SUPPORT-HP - Easy-to-use Online RMA Portal for Simplified Warranty Claim Submissions - FireFly SMART RMA Boxes for Convenient Bulk Warranty Returns and Bulk Paid Repairs - Unlimited Chromebook Technical Support by Phone or Email from Google-Certified Engineers - Access to FireFly Repair Zone Website for Easy Ordering of Chromebook Parts and Repairs - Complimentary Assistance Claiming Free Offers, when available	0.00	0.00



FireFly Computers
 1271 Red Fox Road
 Saint Paul, MN 55112
 fireflycomputers.com

Quote #: E000014610

Hickman County Schools
 Brad Gilbert
 931-729-3391
 brad.gilbert@hickmank12.org

Customer Number	Quote Date	Expiration Date	Terms
70338	2/3/2020	6/12/2020	Net 30

Ryan Lapadat
 Direct: 651-400-1042
 Fax: 612-392-2155
 Email: RLapadat@fireflycomputers.com

Sale Amount: 249.00
Freight: 0.00
Sales Tax: 0.00

Total Amount: 249.00

Terms And Conditions:

Prices reflect a 3% discount for cash/check payment. Credit card payment is accepted without discount. This quote is confidential and is to be viewed solely by individuals within the organization to whom it is addressed. Unauthorized distribution or disclosure of the contents of this quote is prohibited. If you are not from the organization addressed, please notify us immediately so we can prepare a quote specific to you. Prices and availability may change without notice prior to the quote expiration date.

Ordering:

Please email purchase orders to orders@fireflycomputers.com or fax orders to 612-392-2155

Questions:

If you have any questions regarding this quote, please feel free to contact your FireFly Account Manager listed above at your convenience. We pride ourselves on providing you a quick response.



HP Chromebook 14A G5

Master productivity with the HP Chromebook 14A G5, a 14" diagonal Chromebook™ with the manageable, secure, and intuitive Chrome OS™. The durable design is driven by the latest AMD processors¹, has future-ready, universal USB-C™ compatibility, and a choice of HD or FHD IPS panel.

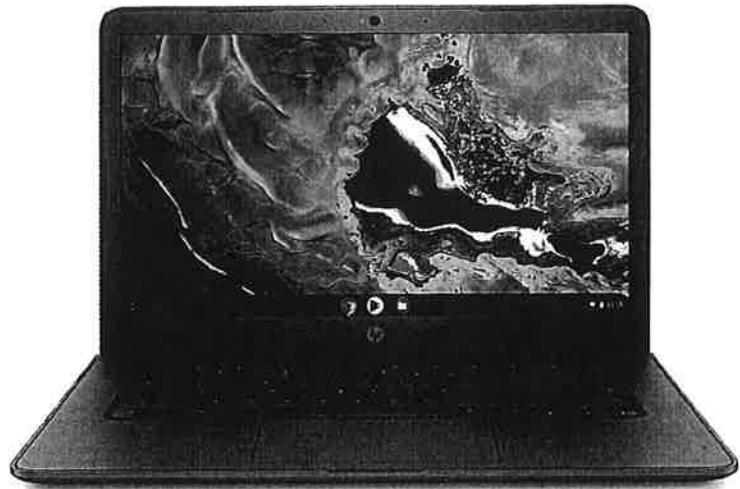

Speed through your day

Launch more apps, quickly browse the web, and manage battery power with the latest AMD processors¹, 4 GB memory, and up to 64 GB eMMC storage². Connect in large spaces with 2x2 802.11ac³ and MIMO⁴ wireless. Charge your device and add accessories with USB-C™.

Durable with a modern aesthetic

Deploy a sleek Chromebook™ that's just <19mm thin⁵ and still stands up to daily wear and tear with a durable 180° hinge. It also undergoes MIL-STD 810G⁶ and IP 41⁷ testing.

Built-in interactivity

Collaborate across the room and the world with an optional FHD IPS touchscreen², 180° hinge that lies completely flat, wide-angle HD webcam, dual mic, and access to Google Meetings⁸. See clearly in dark rooms with the optional backlit keyboard.²

- Get a low-maintenance experience with the automatic software updates and virus protection of the Chrome OS™.⁶
- Use the USB-C™ port to access and charge your USB-C™ accessories from your Chromebook™ or charge your Chromebook™ from any USB-C™ adapter.
- Search, stream, and collaborate through the school day and beyond with a long battery life. Recharge with HP Fast Charge Technology, which gives you 90% battery life in just 90 minutes.⁹
- Help prevent degradation, water intrusion, and tampering with a keyboard that resists picks, minor spills, and key removal. Choose an optional backlit keyboard for easy navigation in dark settings.²
- Take control of the classroom, manage class PCs, and collaborate with students with the intuitive toolset of HP Classroom Manager.¹⁰
- Add an extra layer of functional, all-day protection with the optional HP Always-On Case that wraps around your Chromebook™ and zips flat.²
- Get access to thousands of innovative enterprise and educational Android™ apps that are instantly shareable and easily manageable through the Google Play™ Store.¹¹
- Rely on support you can trust with HP's world-class limited warranty.

HP Chromebook 14A G5 Specifications Table



Available Operating System	Chrome OS™
Processor Family	AMD A6-Series APU processor; AMD A4-Series APU processor
Available Processors	AMD A6-9220C APU with Radeon™ R5 Graphics (1.8 GHz base clock, up to 2.7 GHz max boost clock, 1 MB cache, 2 cores) AMD A4-9120C APU with Radeon™ R4 Graphics (1.6 GHz base clock, up to 2.4 GHz max boost clock, 1 MB cache, 2 cores) <small>1,2,3</small>
Maximum Memory	4 GB DDR4-1866 SDRAM (Onboard memory, Supports Single Channel Memory.)
Internal Storage	16 GB up to 64 GB eMMC 5.0 ⁴
Display ^{6,8,9,10}	14" diagonal FHD IPS BrightView WLED-backlit touch screen, 220 cd/m ² , 100% sRGB (1920 x 1080) 14" diagonal HD SVA BrightView WLED-backlit touch screen, 220 cd/m ² , 100% sRGB (1366 x 768) 14" diagonal FHD IPS anti-glare WLED-backlit, 220 cd/m ² , 100% sRGB (1920 x 1080) 14" diagonal HD anti-glare WLED-backlit, 220 cd/m ² , 100% sRGB (1366 x 768)
Available Graphics	Integrated: AMD Radeon™ R5 Graphics; AMD Radeon™ R4 Graphics ⁶ (Support HD Decode, DX12, and HDMI 1.4b.)
Wireless Technologies	Qualcomm® Wireless-AC 802.11 a/b/g/n/ac (2x2) Wi-Fi® and Bluetooth® 4.2 Combo, non-vPro™ ⁵ (MU-MIMO supported)
Expansion Slots	1 multi-format digital media reader (Supports SD, SDHC, SDXC.)
Ports and Connectors	2 USB 3.1 Type-C™ Gen 1 (Power delivery, DisplayPort™); 2 USB 2.0; 1 Stereo headphone/microphone combo jack
Audio	HD audio, dual speakers, integrated microphone
Input Device	Full-size textured island-style keyboard, spill-resistant, pick resistant and optional backlit; ⁷ ; Touchpad with multi-touch gesture support, taps enabled as default
Camera	720p HD camera ⁶
Available Software	HP Classroom Manager; Google One ^{11,12}
Security Management	H1 Security IC; Nano Security lock slot ¹⁴
Management Features	Management Console ¹³
Power	HP Smart 45 W USB Type-C™ adapter ¹⁸ HP Long Life 2-cell, 47.36 Wh Li-ion polymer ^{16,17} Up to 9 hours ¹⁵ Battery is internal and not replaceable by customer. Serviceable by warranty.
Dimensions	13.26 x 8.93 x 0.72 in 33.7 x 22.6 x 1.83 cm
Weight	Starting at 3.48 lb Starting at 1.57 kg (Weight will vary by configuration.)
Environmental	Low halogen; TCO 8.0 Certified ²¹
Energy Efficiency Compliance	ENERGY STAR® certified; EPEAT® Silver ²⁰
Warranty	HP Services offers 1 year and 90 day limited warranty options depending on country. Batteries have a default 1 year limited warranty except for Long Life batteries which will have same 1 year or 3 year limited warranty as the platform. On-site service and extended coverage is also available. HP Care Pack Services are optional extended service contracts that go beyond the standard limited warranties. Service levels and response times for HP Care Packs may vary depending on your geographic location. To choose the right level of service for your HP product, use the HP Care Pack Services Lookup Tool at: http://www.hp.com/go/cpc ¹⁹

FF firefly **PRE-DEPLOYMENT SERVICES**

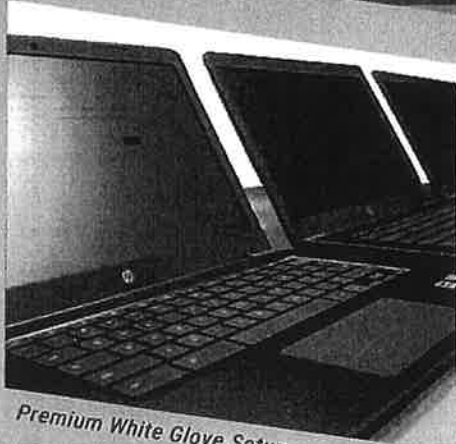

Premium White Glove Setup

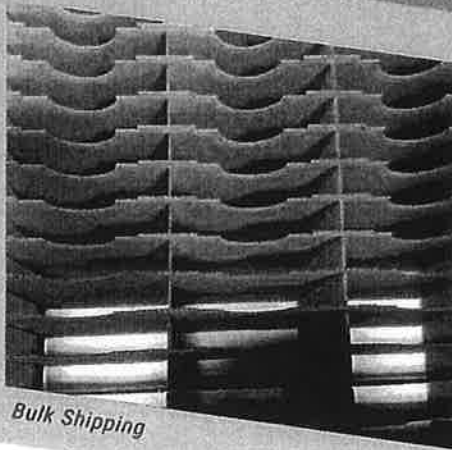

Bulk Shipping

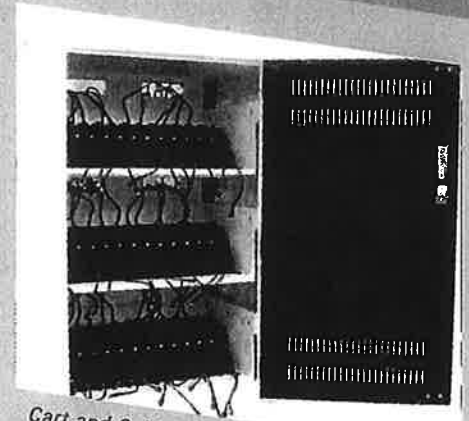

Cart and Cabinet Pre-Wiring

DEPLOYMENT SOLUTIONS

WE DO THE WORK. YOU GET THE CREDIT.



1-TO-1 MADE EASY

Chromebook solutions for a pain-free deployment:

Premium White Glove Setup

- Enroll in Google Apps domain
- Pre-configure WiFi settings
- Update Chrome OS to the latest stable release
- Basic testing to replace defective and DOA units
- Apply district-specific settings and customizations
- Assign subsets of devices to specific OUs, if desired

Etching and Asset Tagging

- Customizable to your district

Bulk Packaging and Shipping

- Eco-friendly packaging saves time, money, and the pain (literally) of opening hundreds of boxes
- Paired with White Glove, it's the fastest way to distribute new devices



CARTS, CASES, AND MORE

More solutions and accessories:

Charging Carts and Cabinets

- Top manufacturers and models for education
- Professionally pre-wired with your adapters
- Devices ship inside carts for easy deployment (by request)

Cases and Shells

- Compare styles and brands with the FireFly Case Demo Box
- Devices pre-installed in cases or shells (by request)

FireFly 48-Hour Chromebook Classroom

- 30-40 HP Chromebooks + Google Licenses shipped in a pre-wired LocknCharge cart and at your school in 2 days

CALL US TOLL FREE | 1-866-950-8868



WARRANTIES, REPAIRS AND MORE



Chromebook Parts + DIY Repair Kit

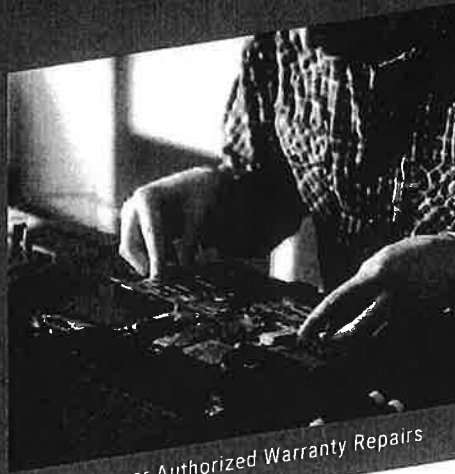

Manufacturer Authorized Warranty Repairs

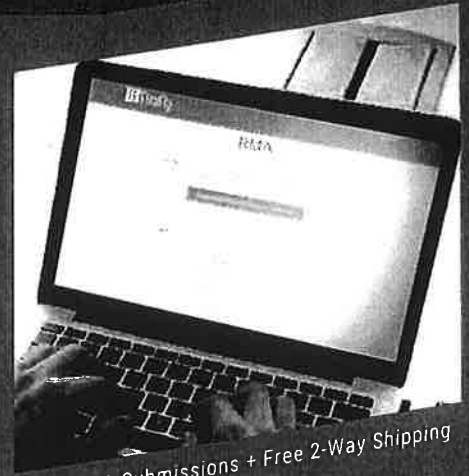

Bulk RMA Submissions + Free 2-Way Shipping

AFFORDABLE AND FLEXIBLE CHROMEBOOK MAINTENANCE



SAVE TIME

Solutions for the time-conscious:

Bulk Online RMA Submissions

- File up to 50 serial numbers on a single ticket
- Spreadsheets accepted

Extended Warranties & Accidental Damage

- Authorized Services Provider for most manufacturers
- Fast turn-around times
- We support self-maintainers - get parts for repairs you want to handle yourself and send the rest to us

FireFly Smart RMA Box

- Free shipping both ways for bulk device repairs
- Convenient packaging provided



SAVE MONEY

Solutions for the budget-conscious:

FireFly Smart Repair™

- All the convenience of a warranty, but only pay for the repairs you need
- Cause of breakage doesn't matter. Serial numbers don't matter. **Usable on any device**, even if you didn't purchase it from us
- Unused credits roll-over from year to year. Add more credits at any time.
- Credits good for professional repairs and Chromebook parts

FireFlyRepairZone.com

- Online portal for finding and buying Chromebook parts

DIY Repair Kit

- Professional tools for two or more technicians to complete nearly every Chromebook repair
- Get started with our free FireFly Student Repair Guide

VISIT US ONLINE | fireflycomputers.com



ABOUT FIREFLY

We're a different kind of IT partner



At FireFly, we focus on helping you be less busy, so you can focus on the things that matter most. It's a philosophy we call "K-12 Technology Made Easy" and it's what's built us into the company we are today - one of the fastest-growing vendors of K-12 technology in the US and one of the top 10 vendors of Google Chrome products worldwide. Whether it's reducing costs, saving time, or **simpli-flying** a process (yep, we went there), we're raising the bar on what a true technology partner can do to make deploying, managing, and maintaining your school technology a breeze.

From Chromebooks and laptops, to pre-wired carts and cabinets, to simple setup, warranty, and repair options, your personal, US-based FireFly Account Manager will make sure **you always get the fast, convenient service you deserve**. Our unique solutions are perfect for everyone from the time-constrained to the budget-minded. At FireFly we're not just another technology vendor, we're K-12 Technology Made Easy... and we look forward to welcoming you to our FireFly Family!

Inc.
500

4 Years! 2016-2019



Google for Education
Partner
Premier



FOCUSED

FireFly is all about K-12, which means our most important customer is *you*. We specialize exclusively in selling, configuring and supporting the best products for education.



INNOVATIVE

We listen hard to the struggles IT departments face and we flip those pain points into unique solutions designed to make your job easier. We're not just a vendor, we're a partner.



PERSONAL

We build relationships, not prospects. Our fast, dedicated Account Managers will give you the personalized service you deserve and make sure your experience is always fantastic.

ONLINE

FIREFLYCOMPUTERS.COM

TOLL-FREE

866-950-8868

PARTS STORE

FIREFLYREPAIRZONE.COM



1271 Red Fox Road, Saint Paul, MN 55112

February 6, 2020

Hickman County Finance Office
Attn: Brad Gilbert, Technology Coordinator
114 North Central Ave.
Suite 203
Centerville, TN 37033

ITB: Chromebooks and Chrome Management Licenses

To Mr. Gilbert and Whom It May Concern,

Introduction

Please accept our enclosed proposal for your *Chromebooks and Chrome Management Licenses* invitation to bid. FireFly Computers is a top national provider of innovative classroom computing solutions for education. Since 2011, we've reimagined what a technology vendor can do to help school administrators meet their technology goals. FireFly focuses on providing knowledgeable, end-to-end customer support and innovative service options to save schools time, effort, and money. Unlike vendors who just focus on the initial sale, our products and services support you throughout the entire device lifecycle, from finding the right equipment to deployment, teacher professional development, warranty support, parts and repairs, and even buy-back for used devices.

FireFly's unique, customer-focused approach has earned us several awards, including four years in a row on the Inc. 5000 list of the fastest-growing companies in America, the Deloitte 'Fast 500' list, and Inc. Magazine's 'Best Workplaces' list 2018. We currently do business with over 2,500 school districts and organizations across all 50 US states. FireFly is a Google for Education Premier Partner and one of the top 10 vendors of Google Chrome products worldwide. We are also an HP Platinum Partner and HP Authorized Services Provider.

At FireFly Computers, we pride ourselves on providing the very best customer service in the educational technology industry. You will have direct access to your own dedicated, US-based, FireFly Account Manager who can help with everything from pre-sales questions to warranty support. This means you'll always get reliable service from someone who knows your account and can provide you with the timely assistance you deserve.

Proposal Overview

We are proposing the HP Chromebook 14A G5 with Google Chrome Education Upgrade (Chrome Management License), and White Glove Setup with Asset Tagging. All products are brand new, and free FOB destination shipping is included. As requested in the bid specifications, our proposal will be valid until June 12th, 2020.

The HP Chromebook 14A G5 is equipped with an AMD A4-9120c Dual-Core Processor with 4GB RAM and 16GB eMMC storage. The 14" HD display is anti-glare, and its front-facing webcam captures video in 720p. To withstand the frequent handling that occurs in a school environment, the Chromebook has a water-resistant keyboard with pick-resistant keys.



Last fall, Google Extended the Auto Update Expiration (AUE) on many Chromebooks currently for sale, as well as new Chromebooks launching in the future. In addition to the extended AUE, the Google Chrome Education Upgrade (formerly Chrome Education License) will have over 200 policies for administrators to use while Google adds even more new features based on educator feedback. In line with these enhancements to the Chrome Education Upgrade, Google is increasing its MSRP from \$30 to \$38 effective on March 9th, 2020. Because of this, our price we offer the Google Chrome Education Upgrade at will change, effective March 2nd, 2020.

Because we want to give the District the option to purchase the Google Chrome Education Upgrade at the lower price of \$24.00, we have provided a quote that reflects the early purchase price. If the District wants to capture the early savings, the Chrome Education Upgrades may be purchased separately from the additional products and services. The Chrome Education Upgrades will remain in the District's account until a Chromebook is available to assign to it. If the District wishes to purchase all line items at the same time after March 2nd, the pricing for the Google Chrome Education Upgrade will change.

FireFly Computers is a stocking partner of HP, which means right now we have over 20,000 HP Chromebook devices in-stock and ready to go in our own private, climate-controlled warehouse, along with thousands more on the way. By controlling our own stock, we're able to avoid backorders and confidently commit to delivering the devices when the District needs them.

FREE Technical Assistance from FireFly Computers Engineers

At FireFly Computers, we have unparalleled experts in deploying 1-to-1 Chromebooks in education. If awarded, our support team will be available to you by phone or email at no additional charge to answer unlimited questions about how to configure your Chrome Management Console or tackle any troublesome issues that arise.

Warranty

FireFly Computers is an HP Authorized Services Provider, which allows us to be a one-stop-shop for any warranty or repair services needed throughout the life of your devices. We make submitting warranty claims easy, just contact FireFly Computers by toll-free phone (866-950-8868), email (rma@fireflycomputers.com), or web (<http://fireflycomputers.com/support/>).

We further simplify and streamline your warranty process through our free FireFly *Smart* RMA™ program. With the delivery of your order, we'll include several FireFly *Smart* RMA™ boxes. Whenever a device needs repair, just record the serial number, insert it into the protective packaging provided, and when you have anywhere from 5-12 devices ready to go, simply contact us for a pre-paid UPS shipping label. Additional *Smart* RMA™ boxes will be replenished as needed throughout the length of the warranty term. This program is solely for your convenience and does not interfere with your rights to send individual devices for repair under the standard warranty terms.

Premium Customizable White Glove Setup with Asset Tagging

Our Google® Certified support team has set up and configured Chrome Management settings for hundreds of thousands of Chromebooks, from large deployments of 10,000+ all the way down to small deployments of just a few dozen devices. We will work with you to go beyond the basic white glove enrollment most vendors offer, and we'll pre-configure your Chromebooks exactly the way you want



them. We can pre-assign Chromebooks to specific OUs (organizational units), apply customized desktop backgrounds, and even sort your shipments into separate groups according to OU, grade level, or school destination. Sometimes this means sorting devices onto separate pallets, but it can also be as simple as us putting a colored sticker on the outside of each box or bulk-shipped device bag that identifies its OU, building, or room designation. No other vendor goes as far as we do to provide the customization and expertise perfect for your unique District's needs. Our typical "White Glove" setup includes:

- Pre-enrolling devices in the District's G Suite (Google Apps) Domain
- Preconfiguring Wi-Fi settings for all devices
- Updating Chrome OS to the latest stable public release
- Applying District-specific settings and customizations to each device, if desired
- Assigning subsets of devices to specific Organizational Units (OUs), if desired
- Basic testing to replace defective and DOA units prior to shipping
- Attaching asset tags to District specifications
- Fully charging the device and powering it down after enrollment

Optional Off-Warranty Parts and Repairs

Many of our customers have chosen to self-maintain their Chromebooks that are no longer under warranty. In support of this effort, FireFly Computers has launched an easy-to-use website for locating and purchasing Chromebook repair parts at <http://fireflyrepairzone.com>. For repairs that are beyond your expertise, or if you're just too busy, our certified technicians can also perform "break-fix" repairs after the warranty period using the same convenient RMA portal and free two-way shipping on devices bulk-packed in our provided Smart RMA boxes. Have a mixture of warrantied and off-warranty devices? No problem. Just submit them all together and we'll sort out which repairs are outside the warranty, send you a quote for the cost of repairs, and wait for your answer on whether to repair each device or just send some of them back unrepaired at no cost. Buying lots of post-warranty parts and repairs? Instead of purchasing them individually, you can pre-purchase a lump-sum of "FireFly Smart Repair Credits" and get a 10% credit bonus. Smart Repair credits never expire and can be used for all off-warranty repairs or individual repair parts.

FireFly has also recently created the first-of-its-kind "FireFly Do-It-Yourself Chromebook Repair Kit." The kit includes the same tools, parts, and supplies our own FireFly technicians use in a unique 5-drawer mobile storage cart. It's enough for two or more simultaneous technicians to perform almost every Chromebook repair. The kit optionally includes access to FireFly's professional online video library of step-by-step Chromebook repair videos and live on-demand consultation with our FireFly Solutions Engineers by phone or email. It's a great way to launch a student repair program and a cost-effective way to extend the life of district technology.



Conclusion

We hope we've helped show you that our proposal provides the very best solution for your upcoming technology purchase. Please let us know if we can send any additional information or answer any questions. FireFly Computers is proud to be a 100% woman-owned small business. Thank you.

Sincerely,

A handwritten signature in black ink, appearing to read 'Kari Phillips', is written over a light blue horizontal line.

Kari Phillips
CEO, FireFly Computers LLC

Primary Sales Contact:

Ryan Lapadat

651-400-1042 (direct)

1-866-950-8868 x 120 (toll-free)

612-392-2155 (fax)

rlapadat@fireflycomputers.com

Bid Specifications for Chromebooks:

Chrome OS

HP preferred but other brands would be considered

14 inch screen (non-touch) preferred

4 GB RAM preferred

16 GB Hard Drive Size Preferred

Wireless Compatible

USB and HDMI ports available

Headphone Jack

Prices are to include shipping and handling charges for delivery, asset tagging/configuration. Chromebooks will be named and assigned to the proper school in Google Admin Console as determined by Hickman County Schools.

Any color choice is determined by Hickman County Schools.

Specifications for Management software:

perpetual license term

36 month support term for Chromebook

Bid price shall be good from February 10th, 2020 through June 12th, 2020. Questions should be directed to Brad Gilbert, Technology Coordinator, at 931-729-3391 Ext. 2229.

Quantity to be ordered is undetermined. A price breakout dependent on quantity purchased will be accepted. There could be multiple orders purchased at different times through the period that the bid is good for.

Y&STechnologies

Solutions that drive results

Date 02/04/2020
Hickman County Schools
Chromebooks and Chrome OS licenses
Brad Gilbert

Vendor Y&STechnologies
383 Kingston AVE STE 357
Brooklyn NY 11213
Email Address: saul@yandstech.com
Cage Code: 5A2W3
D&B# 82-8859616
FED# 61-1569225
Type of business: S Cooperation

Chromebooks and Chrome OS licenses

Proposal

Dear Brad,

After extensive research for the **Chromebooks** we are suggesting **2 solution from Lenovo**. Lenovo will not release a product into the market unless the product meets their highest standards. They make their product very strong and durable and that is why you can spill water on their keyboards and drop their laptops from a table and in most cases nothing will happen to the product. **Gartner**, an independent and well known testing lab actually rates Lenovo as the leader in this industry.

With that in mind, two years ago Lenovo became the largest PC manufacturer in the world and they are the only PC manufacturer which has actually grown in the last few years while DELL and HP have shrunk. Lenovo has expanded its high tech offering by purchasing IBM's X series server line and purchasing Google's Motorola line of cell phones so that they can offer full line of products in the high tech sector.

Option 1

100e Chromebook MFR# 81QB0000US Lenovo 100e Chromebook 2nd Gen, **MTK 8173C** (1.70 GHz,), **11.6 1366x768, Google Chrome, 4.0GB, 1x32GB EMMC**, Gray, Imagination GX6250, 802.11 2*2+5.0, 720p Camera, 3 Cell Li-Polymer, **HDMI and USB Ports. Google AUE Jun 2025. 1 Year Mail-in**

Y&Stechnologies

Solutions that drive results

Google License

We are offering as requested. Please note Google License pricing is valid till March 9th as Google is rising their prices by \$4 a unit.

Pricing for Option 1

Part Number	Description	Qty.	Unit Price
	Computer		
81QB0000US	Lenovo 100e Chromebook 2nd Gen MTK, MTK MTK 8173C (1.70 GHz,), 11.6 1366x768 11.6 1366x768, Google Chrome, 4.0GB, 1x32GB EMMC, Gray, Imagination GX6250, 802.11 2*2+5.0, 720p Camera , 3 Cell Li-Polymer, 1 Year Mail-in	1	\$148.91
Google License	Google Chrome License (Please note Google License pricing is valid till March 9th as Google is rising their prices by \$4 a unit)	1	\$23.70
ChromeOS White Glove Configuration Services	ChromeOS White Glove Configuration Services	1	\$4.99
Asset Tagging of Chromebooks	Asset Tagging of Chromebooks	1	\$2.49

Option 2

We are offering the **Lenovo 14e Chromebook MFR# 81MH0006US 14" Chromebook - 1920 x 1080 - A-Series A4-9120 - 4 GB RAM - 32 GB Flash Memory - Chrome OS - AMD Radeon R3 Graphics - Twisted nematic (TN) - English (US) Keyboard - Bluetooth 32GB 14IN BT CHROME. Two Type-C USB 3.0, two USB 3.0. Google AUE Jun 2026. 1 Year Mail-in warranty.**

Google License

We are offering as requested. Please note Google License pricing is valid till March 9th as Google is rising their prices by \$4 a unit.

Y&Stechnologies

Solutions that drive results

Pricing for Option 2

Part Number	Description	Qty.	Unit Price
	Computer		
81MH0006US	Lenovo 14e Chromebook MFR# 81MH0006US 14" Chromebook - 1920 x 1080 - A-Series A4-9120 - 4 GB RAM - 32 GB Flash Memory - Chrome OS - AMD Radeon R3 Graphics - Twisted nematic (TN) - English (US) Keyboard	1	\$218.00
Google License	Google Chrome License. (Please note Google License pricing is valid till March 9th as Google is rising their prices by \$4 a unit).	1	\$23.70
ChromeOS White Glove Configuration Services	ChromeOS White Glove Configuration Services	1	\$4.99
Asset Tagging of Chromebooks	Asset Tagging of Chromebooks	1	\$2.49

Datasheets

Y&S has provided datasheets of all items we are suggesting.

Optional Warranties for – Optional Warranties and Pricing for the Lenovo Chromebooks

Y&Stechnologies

Solutions that drive results

Part Number	Description	Unit Price
5WS0H71477	Lenovo Warranty/Support - 1 Year Upgrade - Warranty - Carry-in/Service Depot - Maintenance - Parts & Labor - Electronic and Physical Service (Lenovo pays freight)	\$7.99
5WS0H71480	Lenovo Warranty/Support - 2 Year Upgrade - Warranty - Carry-in/Service Depot - Maintenance - Parts & Labor - Electronic and Physical Service (Lenovo pays freight)	\$14.99
5WS0H71479	Lenovo Warranty/Support - 4 Year Upgrade - Warranty - Carry-in/Service Depot - Maintenance - Parts & Labor - Electronic and Physical Service (Lenovo pays freight)	\$29.25
5WS0M77013	Lenovo Warranty/Support - 4 Year Upgrade - Warranty - Carry-in/Service Depot - Maintenance - Parts & Labor - Electronic and Physical Service (Lenovo pays freight)	\$49.50
5WS0H71477 and 5PS0K75680	Lenovo Depot Repair + ADP - Extended service agreement - parts and labor - 1 year	\$22.85
5WS0H71480 and 5PS0K75679	Lenovo Depot Repair + ADP - Extended service agreement - parts and labor - 2 years	\$44.00
5WS0H71479 and 5PS0K75681	Lenovo Depot Repair + ADP - Extended service agreement - parts and labor - 3 years	\$66.00
5WS0N75564 and 5PS0F04090	Lenovo Depot Repair + ADP - Extended service agreement - parts and labor - 4 years	\$90.00

Price Valid

Our price is valid till June 12th 2020 for the chromebooks and March 9th for the Google licenses. If you purchase Google licenses after March 9th there will be a \$4 increase.

Contact Info for Warranty Support

For support on the Lenovo equipment, the district can contact either Lenovo support directly or contact our customer Service Dept. The Phone number for Lenovo support is #800-426-7378 or our Customer support at #888-491-8910.

Y&S Technologies

Solutions that drive results

Acceptance terms and conditions

Y&S Technologies acknowledge and accepts all contract terms on the bid

Lead Time

We can provide delivery of the equipment in **15 days or less** and our price includes shipping and handling

Y&S References

Y&S has a vast experience in supplying, installing and configuring Lenovo Chromebooks all over the country. Here are a few references for your convenience.

- 1) **Bridgeport Public Schools, Bridgeport CT** (Largest School District in CT). We have provided over **7000 Chromebooks with White Glove, Laser Etching and installation services in the last 2 years'** worth **\$2,000,000**, and we are in the process of supply an additional 1500 Chromebooks to the public schools. Point of contact is Allen Fuchs who is the Assistant Director of Information Technology. Ph #203-275-1102, E-mail afuchs@bridgeportedu.net.
- 2) **Carbon School District.,PRICE, UT.** We sold them over **\$150,000** worth of lenovo Chromebooks in **July of 2018**. Point of contact is Phil Feichko IT director who can be reached at feichkop@gmail.com
- 3) **Wilton Public Schools, Wilton Ct.** we sold them over **\$2,000,000** worth of Lenovo equipment in 2016/2017 and **2,500 Lenovo Chromebooks with White Glove, Laser Etching and installation services in the last 2 years**. The point of contact is Helaine Walker who is the director of IT Helaine can be reached at 203-762-3381x8326 Email walkerh@wiltonps.org
- 4) **Grand County School District, Moab, UT.** We sold them over **\$150,000** worth of Lenovo equipment in 2017. Point of contact is Eric Still Director of IT who can be reached at 435-259-6909 or by E-mail at stille@grandschools.org
- 5) **Emery School District, Huntington UT.** We sold them over \$75,000 worth of Lenovo equipment in 2017 Point of contact is Doug Johnson Director of IT who can be reached at 435-687-9846 or by E-mail at Doug@emeryschools.org
- 6) **Community College of Denver, Denver CO.** We have sold the over **\$1,000,000** Worth Of lenovo equipment in the last 3 years and are currently in the process of supplying an additional \$200,000 worth of Lenovo Computers, Laptops, and workstations. The point of Contact is Chris Arcarese who can be reached at **(303) 352-3032**
Chris.Arcarese@ccd.edu

Point of Contact

Saul Finck (Sales Manager) will be your point of contact for this contract and will assist the School Districts and its personnel in any matters related to this contract. Saul's Contact Information is as follows: PH #718-473-0284x203.Fax number 718-360-9627 E-mail Saul@yandstech.com

*Y&S*Technologies

Solutions that drive results

Insurance

Y&S Technologies maintains all required commercial insurance policies and will be more than happy to provide proof of insurance if the School District requests it.

Brief History of our Company

Y&S Technologies have been in business for over thirteen years with our primary focus on the education and government sector. Our senior staffs have over 40 years of combined experience, selling and servicing the academic and government market. Y & S Technologies was established in the midst of the worst recession since the Great Depression. We have not only survived but we have grown our business every year by a minimum of 20%. We offer our customers highly competitive solutions, the best products at the best prices, and a high level of service and support. These directly contribute to our successful and expanding business. If you should need any further information please feel free to contact me at your earliest convenience. Thank you for the opportunity to do business with your organization.

Saul Finck

Sales Manager
Y&S Technologies

New Year. New 100e Chromebook.

SCHOOL'S IN SESSION, AND THE 100e CHROMEBOOK IS READY TO WORK.

Engineered to earn perfect attendance, the 100e never takes a day off from learning. Its powerful, portable design features state-of-the-art learning tools that will suit any size school or budget. And thanks to its user-friendly interface, students and teachers can easily access Google Classroom, G Suite for Education and today's most popular education apps, all through their own personalized Google IDs. Plus, the Chrome Education license allows school administrators to control their entire fleet of devices, so safety and security always remain top of mind. And if you're worried about durability, don't be. The 100e was built to withstand even the most chaotic of classrooms. All-in, this machine was made to excel in every learning environment.

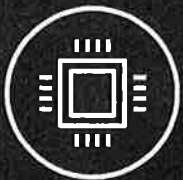
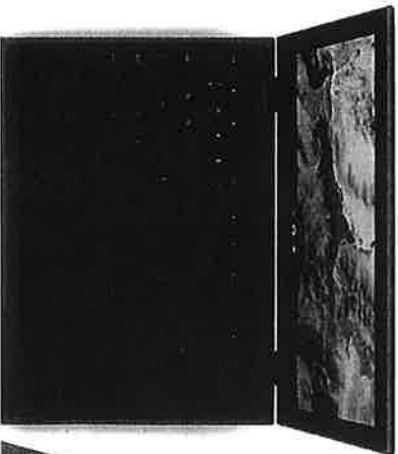

A+ ACCESSIBILITY

From its easy-to-use interface to its powerful MediaTek Processor, the 100e is a total learning tool. Thanks to its unparalleled speed, there's never any lag time when it comes to learning; students can always depend on immediate access to their assignments and favorite education apps. And between Google Classroom and G Suite for Education, teachers can easily stay organized and promote a collaborative learning environment where students share work and stay connected all year long.



BUILT FOR BUMPS

From class to class, hallways to backpacks to bus rides, the 100e was built with every busy student in mind. That's why its sleek design features rubber bumpers that can handle a drop up to 75 cm and reinforced ports for all those unintentional bumps along the way. When you factor in the mechanically anchored keys and water-resistant design, you've got a machine tough enough to last an entire school year.



BIG FEATURES, COMPACT CHROMEBOOK

The 100e is light done right. Weighing in at only 2.68 lbs, the 100e is effortless to carry, but full of powerful possibilities. With up to 10 hours* of battery life, students can spend more time on their schoolwork and less time worrying about charging their PCs. Plus, its anti-glare display helps put a little less eye strain on screen time.

*Based on Google Chrome Power. LoadTest, a battery run down test. For more information about Google Chrome Power, LoadTest, visit www.chromium.org. Test results should be used only to compare one product with another and are not a guarantee; you will experience the same battery life. Battery life may be significantly less than the test results and varies depending on your product's configuration, software, usage, operating conditions, power management settings and other factors. Maximum battery life will decrease with time and use.

Lenovo 100e Chromebook (MTK)

PERFORMANCE

Processor	MediaTek™ 8173C Processor
Operating System	Chrome OS™
Graphics	Imagination GX6250 Integrated graphics
Memory	4 GB
Storage	32GB eMMC
Audio	3.5mm Combo Audio
Battery	42 Whr, Up to 10 hrs*

DESIGN

Display	11.6" HD antiglare display (1366x768) TN 250
Camera	720p Front-Facing Camera
Dimensions	290 x 204 x 20.4mm / 11.41" x 8.03" x .80"
Weights	1.21kg, 2.68lbs
MIL-SPEC Standard	Yes
Keyboard	Water-resistant (330 ml) with touchpad & mechanically anchored keys
Durability Features	Reinforced ports & hinges, drop-resistant up to 29.5" (75cm)

CONNECTIVITY

Ports & Slots	1 x USB-C, 1 x USB 3.0, HDMI, WiFi 802.11 AC (2 x 2), Bluetooth 4.2, Micro SD card reader Combo mic / audio jack, Kensington lock slot
---------------	--

lenovo.com/chromebook

Lenovo reserves the right to alter product offerings and specifications at any time, without notice. Lenovo makes every effort to ensure accuracy of all information but is not liable or responsible for any editorial, photographic or typographic errors. All images are for illustration purposes only. For full Lenovo product, service and warranty specifications visit www.lenovo.com. Lenovo makes no representations or warranties regarding third party products or services. Trademarks: The following are trademarks or registered trademarks of Lenovo: Lenovo, the Lenovo logo, Ideapad, IdeaCentre, yoga and yoga home. Microsoft, Windows and Vista are registered trademarks of Microsoft Corporation. Ultrabook, MediaTek, Imagination GX are trademarks or registered trademarks of MediaTek Corporation in the U.S. and/or other countries. Chromebook is a registered trademark of Google Inc. Other company, product and service names may be trademarks or service marks of others. Battery life (and recharge times) will vary based on many factors including system settings and usage. Visit www.lenovo.com/lenovo/us/en/safetycomp/ periodically for the latest information on safe and effective computing. ©2019 Lenovo. All rights reserved.

*Based on Google Chrome Power LoadTest, a battery run down test. For more information about Google Chrome Power LoadTest, visit www.chromium.org. Test results should be used only to compare one product with another and are not a guarantee you will experience the same battery life. Battery life may be significantly less than the test results and varies depending on your product's configuration, software, usage, operating conditions, power management settings and other factors. Maximum battery life will decrease with time and use.



LENOVO OFFERINGS & SERVICES

Chrome Education license

Chrome Education license enables IT administrators to manage a few or a fleet of Chrome devices within a centralized, easy and intuitive software interface. Lenovo makes it easy to acquire as an OEM authorized reseller of Chrome Education license.

Warranty upgrades - onsite and next business day

Maximize PC uptime and productivity by providing convenient, fast repair service at your organization.

Warranty extensions (1-3 years total duration)

This fixed-term, fixed-cost service helps accurately budget for Chromebook expenses, protects your valuable investment and lowers the cost of ownership over time.

Accidental damage protection

Avoid the hassles of unexpected repair costs. Provides coverage for non-warranted damage incurred under normal operating conditions, such as minor spills, drops or screen damage.

G Suite for Education

Easy access to Google's G Suite family of apps keeps everything under one roof and free of software licensing fees. Simple cloud management and 24/7 support make Chromebooks easily scalable to any size classrooms, big or small.

OPTIONS / ACCESSORIES



Lenovo USB-C Travel Hub



Lenovo Wireless Mouse Keyboard



On-Ear-Headphones



An all-in-one school solution.

DISCOVER THE NEW 14e CHROMEBOOK, EVERY EDUCATOR'S BEST RESOURCE.

Empower your teachers' passions with the all-new 14e Chromebook. This smart, high-tech machine was designed to help your teachers inspire new, creative ways of learning in the classroom. With access to thousands of popular education apps and tools like G Suite for Education, teachers can engage and excite students to share and connect across a variety of subjects. Plus, with the help of Google Classroom, communication and organization in and outside the classroom has never been easier. When you combine all that with the speed, simplicity, security, and versatility of the Chrome Operating System, the 14e Chromebook is the solution your school has been searching for.

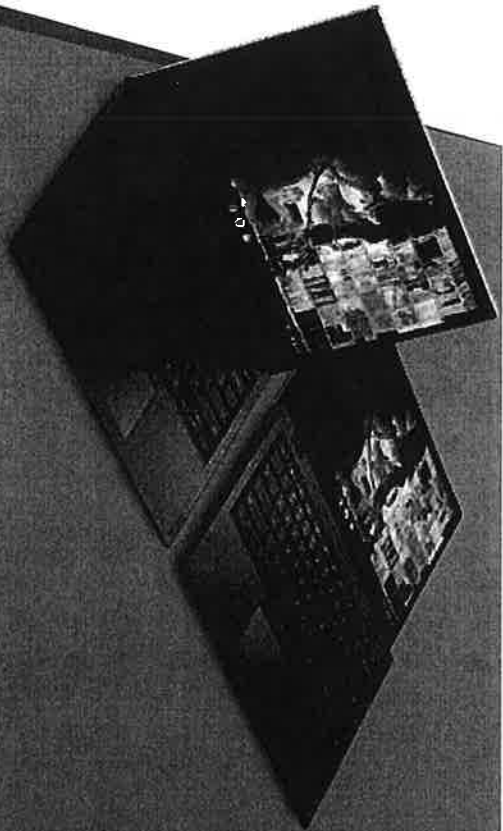

SIMPLE TO USE, EASY TO MANAGE

Experience an easier way to manage your school's fleet of devices with Chrome Education Software on the 14e. This software makes it easy to monitor the security and location of all your machines in a single school or across the region, all from one central location. Plus, thanks to personalized Google IDs, the setup is simple, and everyone can easily access their data and docs from the cloud, even if the device is shared by more than one faculty member.

PERFECTLY PORTABLE, RUGGEDLY RELIABLE

Designed to be carried between classes and easily fit into any work bag, the 14e Chromebook weighs a whopping 3.27lbs and is only 17.7mm thick. In addition to its compact design, the 14e boasts rugged reinforcements around ports and hinges for added durability. Plus, the water-resistant keyboard and mechanically anchored, anti-peel keys provide extra protection from common classroom water accidents.

POWERED TO PERFORM

The 14e Chromebook is always ready and waiting for your fingertips to get to work. Its CleanSheet design is backed by a 2.5 GHz A41 AMD[®] dual-core processor and up to 10 hours¹ of battery life. Add in up to 8GB of RAM and 64GB² of storage and you've got a device that can masterfully handle any size project with unparalleled speed and sufficient capacity.

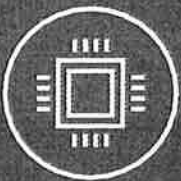

How do satellites work?

Did Newton invent the satellite?

Newton's theory of gravity and his discovery of the laws of motion led to the development of the satellite. He discovered that the force of gravity is what keeps the satellite in orbit around the Earth. His theory of gravity is what allows us to launch satellites into space.

¹Based on average Chrome OS power load, not a battery for game play. For more information about the Chrome OS battery life, visit www.lenovo.com/lenovo/en/lenovo-14e-chromebook.
²Storage requirements: Total available storage is subject to configuration. Storage with interface and overhead is guaranteed. All expected values are based on average use. Actual performance may vary. Performance and other specifications are subject to change without notice. © 2014 Lenovo. All rights reserved. Lenovo, the Lenovo logo, and other marks are trademarks of Lenovo. All other marks are the property of their respective owners.

Lenovo 14e Chromebook

PERFORMANCE

Processor	2.4 GHz A4 AMD® dual-core processor
Operating System	Chrome OS™
Graphics	AMD® Integrated graphics
Memory	4GB, 8GB DDR4
Storage	32GB or 64GB eMMC
Audio	3.5mm Combo Audio
Battery	57 Whr, Up to 10 hrs*

DESIGN

Display	14" FHD TN & FHD IPS touch Option
Camera	HD w/2 Mic
Dimensions	328 x 225 x 17.7mm / 12.91" x 8.85" x 0.69"
Weights	1.21kg, 3.27 lbs
MIL-SPEC Standard	Yes
Keyboard	Full-sized, water-resistant (330 ml) with touchpad & mechanically anchored keys. Black-lit option available.

CONNECTIVITY

Ports & Slots	2 x USB-C, 2 x USB 3.0, WiFi 802.11 AC (2 x 2), Bluetooth 4.2, Micro SD card reader, Combo mic / audio jack, Kensington lock slot
---------------	---

lenovo.com/chromebook

Lenovo reserves the right to alter product offerings and specifications at any time, without notice. Lenovo makes every effort to ensure accuracy of all information but is not liable or responsible for any editorial, photographic or typographic errors. All images are for illustration purposes only. For full Lenovo product, service and warranty specifications visit www.lenovo.com. Lenovo makes no representations or warranties regarding third party products or services. Trademarks: The following are trademarks or registered trademarks of Lenovo: Lenovo, the Lenovo logo, ideapad, ideacentre, yoga and yoga home, Microsoft, Windows and Vista are registered trademarks of Microsoft Corporation, AMD, the AMD Arrow logo, and combinations thereof are trademarks of Advanced Micro Devices, Inc. in the United States and/or other jurisdictions. Chromebook is a registered trademark of Google Inc. Other company, product and service names may be trademarks or service marks of others. Battery life (and recharge times) will vary based on many factors including system settings and usage. Visit www.lenovo.com/lenovo/us/env/safecomp/ periodically for the latest information on safe and effective computing. ©2019 Lenovo. All rights reserved.

*Based on Google Chrome Power_LoadTest, a battery run down test. For more information about Google Chrome Power_LoadTest, visit www.chromium.org. Test results should be used only to compare one product with another and are not a guarantee you will experience the same battery life. Battery life may be significantly less than the test results and varies depending on your product's configuration, software, usage, operating conditions, power management settings and other factors. Maximum battery life will decrease with time and use.

LENOVO OFFERINGS & SERVICES

Chrome Education license

Chrome Education license enables IT administrators to manage a few or a fleet of Chrome devices within a centralized, easy and intuitive software interface. Lenovo makes it easy to acquire as an OEM authorized reseller of Chrome Education license.

Warranty upgrades - onsite and next business day

Maximize PC uptime and productivity by providing convenient, fast, repair service at your organization.

Warranty extensions (1-3 years total duration)

This fixed-term, fixed-cost service helps accurately budget for Chromebook expenses, protects your valuable investment and lowers the cost of ownership over time.

Accidental damage protection

Avoid the hassles of unexpected repair costs. Provides coverage for non-warranted damage incurred under normal operating conditions, such as minor spills, drops, or screen damage.

G Suite for Education

Easy access to Google's G Suite family of apps keeps everything under one roof and free of software licensing fees. Simple cloud management and 24/7 support make Chromebooks easily scalable to any size classrooms, big or small.

OPTIONS / ACCESSORIES

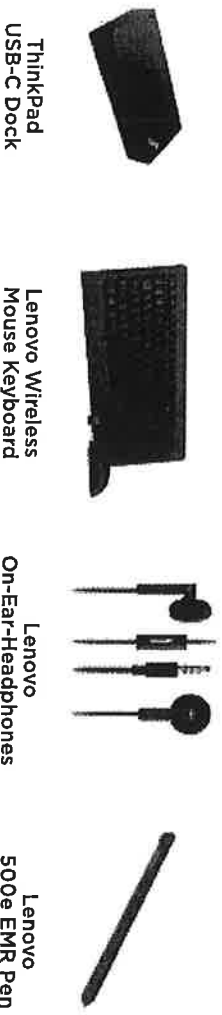

ThinkPad
USB-C Dock

Lenovo Wireless
Mouse Keyboard

Lenovo
On-Ear-Headphones

Lenovo
500e EMR Pen

Invitation to Bid

The Hickman County Finance Office is accepting bids for a School Tractor/Equipment.

Specifications can be found at www.hickmank12.org/request-for-proposal or available by calling 931-729-3391 Ext. 3.

Sealed bids must be mailed or hand delivered to the Hickman County Finance Office, 114 North Central Avenue, Suite 203, Centerville, TN 37033 and clearly marked on the outside of the envelope "School Tractor/Equipment".

Bids will be opened on Monday, May 4, 2020 at 10:00 a.m. in the Finance Office.

The Hickman County Board of Education reserves the right to accept or reject any and all bids or parts of bids and to waive any informalities that would prevent the acceptance of a better bid.

Tri-Green Equipment = \$ 26,780⁷⁹
J.D. 4044M

Tri-Green Equipment = \$ 24,317⁵¹
JD 3033R

Tri-Green Equipment = \$ 20,959¹¹
JD 3032E

Presert
Cardi Daws
C. Fitzgerald

Tractor bid form:

FACTORY OR DEALER PACKAGE DEAL:

Company: _____ Tractor/model/HP proposed: _____ / _____ / _____

Price delivered complete with installed loader and attachments: \$ _____

In event this tractor is a package deal tractor list all implements above the minimum required specifications listed that are being included as a "bonus package" in the price above:

SPECIAL NOTES: REGARDING FEATURES OF TRACTOR OR IMPLEMENTS THAT "bidder" WOULD LIKE TO NOTE to be CONSIDERED IN the bid:

NON PACKAGE OR IMPLEMENT PRICING

(Only Minimum Bid Specification TRACTOR and equipped as specified with loader, mower, quick detach offerings.)

Company: TriGreen Equipment Tractor/model/HP proposed: John Deere / 3033R / 33 HP
\$ 24,317.51 price is complete with all attachments installed and delivered.

Tractor base price \$ 23,933.61

For just the Tractor/ Loader installed /turf tires priced only: 23,933.61

Clarifications in

notes: Loaders are factory installed that is why prices
do not change much.

For additional multiple models and priced tractors to be proposed, print, complete and attach additional sheets of this form to back. (All questions may be directed to Mike Plunkett 931-306-7401 (cell))

Implements Not specified in the bid, but being offered at special \$ discount pricing below to schools for Athletic Sports teams in event they wish to use this bid during its deadline duration of 12 months from the date of bid award.

Implement offered

minimum HP to use:

Normally Priced

Special pricing:

LMC spreader / 16 HP / 835.62 / 696.51

5ft grooming mower 20 HP / 3750.91 / 3,205.62

3 pt. sprayer / 25 HP / 1950.00 / 1,675.42

_____ / _____ / _____ / _____



JOHN DEERE

Quote Id: 21666941

21 April 2020

Hickman County Schools Hickman County High School
1645 Bulldog Blvd
Centerville, TN 37033

Thank you for allowing TriGreen Equipment to quote your equipment needs. TriGreen is committed to providing affordable property solutions for the farm, home, and worksite.

John Deere quality and reliability is unsurpassed when backed by TriGreen sales, parts, and service support. To enhance your ownership experience TriGreen is proud to offer our exclusive Encore Performance Programs which allows you to prepay your annual maintenance, extend factory warranty, and help control total cost of ownership.

Thank you for the opportunity to be your equipment solutions provider.

Patrick Perry
615-229-2400
TriGreen Equipment LLC



Quote Summary

Prepared For:

Hickman County Schools Hickman County High School
1645 Bulldog Blvd
Centerville, TN 37033

Prepared By:

Patrick Perry
TriGreen Equipment LLC
707 Henslee Drive
Dickson, TN 37055
Phone: 615-229-2400
patrickperry@trigreen.com

Quote Id: 21666941
Created On: 21 April 2020
Last Modified On: 01 May 2020
Expiration Date: 31 May 2020

Equipment Summary	Suggested List	Selling Price	Qty	Extended
JOHN DEERE 3033R Compact Utility Tractor (24 PTO hp) TriGreen Secure	\$ 32,931.90	\$ 24,317.51 X	1 =	\$ 24,317.51
	Pay As You Go			

Equipment Total **\$ 24,317.51**

Quote Summary

Equipment Total	\$ 24,317.51
SubTotal	\$ 24,317.51
Est. Service Agreement Tax	\$ 0.00
Total	\$ 24,317.51
Down Payment	(0.00)
Rental Applied	(0.00)
Balance Due	\$ 24,317.51

Salesperson : X _____

Accepted By : X _____



JOHN DEERE

Selling Equipment

Quote Id: 21666941

Customer: HICKMAN COUNTY SCHOOLS HICKMAN COUNTY HIGH SCHOOL

JOHN DEERE 3033R Compact Utility Tractor (24 PTO hp)

Hours:

Suggested List

Stock Number:

\$ 32,931.90

Selling Price

\$ 24,317.51

Code	Description	Qty	Unit	Extended
1369LV	3033R Compact Utility Tractor (24 PTO hp)	1	\$ 24,642.00	\$ 24,642.00

Standard Options - Per Unit

0202	United States	1	\$ 0.00	\$ 0.00
0409	English Operator's Manual and Decal Kit	1	\$ 0.00	\$ 0.00
1520	eHydro™	1	\$ 1,393.00	\$ 1,393.00
1701	Factory Installed Loader with Bucket	1	\$ 6,143.00	\$ 6,143.00
2000	Open Station with Standard Seat	1	\$ 0.00	\$ 0.00
2650	Less Radio	1	\$ 0.00	\$ 0.00
3320	Dual Mid Selective Control Valve	1	\$ 0.00	\$ 0.00
3400	Less Mid PTO	1	\$ 0.00	\$ 0.00
4061	Less iMatch™ Quick Hitch Category 1	1	\$ 0.00	\$ 0.00
5223	41x14-20 (4PR, R3 Turf, 2 Position)	1	\$ -232.00	\$ -232.00
6223	27x8.5-15 (6PR, R3 Turf, 2 Position)	1	\$ 70.00	\$ 70.00

Standard Options Total

\$ 7,374.00

Dealer Attachments

LVB25976	iMatch™ Quick-Hitch Category 1 with adjustable top hook	1	\$ 383.90	\$ 383.90
----------	---	---	-----------	-----------

Dealer Attachments Total

\$ 383.90

Value Added Services

TriGreen Secure

Value Added Services Total

\$ 0.00

Other Charges

Freight	1	\$ 532.00	\$ 532.00
---------	---	-----------	-----------

Other Charges Total

\$ 532.00

Suggested Price

\$ 32,931.90

Customer Discounts

Customer Discounts Total

\$ -8,614.39

\$ -8,614.39

Total Selling Price

\$ 24,317.51

Tractor bid form:

FACTORY OR DEALER PACKAGE DEAL:

Company: _____ Tractor/model/HP proposed: _____ / _____ / _____

Price delivered complete with installed loader and attachments: \$ _____

In event this tractor is a package deal tractor list all implements above the minimum required specifications listed that are being included as a "bonus package" in the price above:

SPECIAL NOTES: REGARDING FEATURES OF TRACTOR OR IMPLEMENTS THAT "bidder" WOULD LIKE TO NOTE to be CONSIDERED IN the bid:

NON PACKAGE OR IMPLEMENT PRICING

(Only Minimum Bid Specification TRACTOR and equipped as specified with loader, mower, quick detach offerings.)

Company: TriGreen Equipment Tractor/model/HP proposed: John Deere / 3032E / 32 HP
\$ 20,959.11 price is complete with all attachments installed and delivered.

Tractor base price \$ 19,659.11

For just the Tractor/ Loader installed /turf tires priced only: 19,659.11

Clarifications in

notes: Loaders come Factory installed thats why prices do not change much.

For additional multiple models and priced tractors to be proposed, print, complete and attach additional sheets of this form to back. (All questions may be directed to Mike Plunkett 931-306-7401 (cell))

Implements Not specified in the bid, but being offered at special \$ discount pricing below to schools for Athletic Sports teams in event they wish to use this bid during its deadline duration of 12 months from the date of bid award.

Implement offered

minimum HP to use:

Normally Priced

Special pricing:

LMC spreader / 16 HP / 835.62 / 696.51

5 ft grooming mower 20 HP / 3,750.91 / 3,205.62

3 pt. sprayer / 25 HP / 1,950.00 / 1,675.42

_____ / _____ / _____ / _____



JOHN DEERE

Quote Id: 21666941

21 April 2020

Hickman County Schools Hickman County High School
1645 Bulldog Blvd
Centerville, TN 37033

Thank you for allowing TriGreen Equipment to quote your equipment needs. TriGreen is committed to providing affordable property solutions for the farm, home, and worksite.

John Deere quality and reliability is unsurpassed when backed by TriGreen sales, parts, and service support. To enhance your ownership experience TriGreen is proud to offer our exclusive Encore Performance Programs which allows you to prepay your annual maintenance, extend factory warranty, and help control total cost of ownership.

Thank you for the opportunity to be your equipment solutions provider.

Patrick Perry
615-229-2400
TriGreen Equipment LLC



Quote Summary

Prepared For:

Hickman County Schools Hickman County High School
1645 Bulldog Blvd
Centerville, TN 37033

Prepared By:

Patrick Perry
TriGreen Equipment LLC
707 Henslee Drive
Dickson, TN 37055
Phone: 615-229-2400
patrickperry@trigreen.com

Quote Id: 21666941
Created On: 21 April 2020
Last Modified On: 01 May 2020
Expiration Date: 31 May 2020

Equipment Summary	Suggested List	Selling Price	Qty	Extended
JOHN DEERE 3032E Compact Utility Tractor TriGreen Secure	\$ 27,909.10	\$ 20,959.11 X	1 =	\$ 20,959.11
	Pay As You Go			
Equipment Total				\$ 20,959.11

Quote Summary

Equipment Total	\$ 20,959.11
SubTotal	\$ 20,959.11
Est. Service Agreement Tax	\$ 0.00
Total	\$ 20,959.11
Down Payment	(0.00)
Rental Applied	(0.00)
Balance Due	\$ 20,959.11

Salesperson : X _____

Accepted By : X _____



JOHN DEERE

Selling Equipment

Quote Id: 21666941

Customer: HICKMAN COUNTY SCHOOLS HICKMAN COUNTY HIGH SCHOOL

JOHN DEERE 3032E Compact Utility Tractor

Hours:

Stock Number:

Suggested List

\$ 27,909.10

Selling Price

\$ 20,959.11

Code	Description	Qty	Unit	Extended
1479LV	3032E Compact Utility Tractor	1	\$ 20,719.00	\$ 20,719.00
Standard Options - Per Unit				
0202	United States	1	\$ 0.00	\$ 0.00
0409	English Operator's Manual and Decal Kit	1	\$ 0.00	\$ 0.00
1701	Factory Installed Loader with Bucket	1	\$ 5,247.00	\$ 5,247.00
4061	Less iMatch™ Quick Hitch Category 1	1	\$ 0.00	\$ 0.00
4110	Draft Links - Flat Bar (Standard)	1	\$ 0.00	\$ 0.00
5213	41x14-20 4PR R3 Turf	1	\$ 20.00	\$ 20.00
6213	27x8.50-15 6PR R3 Turf	1	\$ 70.00	\$ 70.00
Standard Options Total				\$ 5,337.00
Dealer Attachments				
LVB25976	iMatch™ Quick-Hitch Category 1 with adjustable top hook	1	\$ 383.90	\$ 383.90
BLV10903	Dual Rear Selective Control Valve	1	\$ 937.20	\$ 937.20
Dealer Attachments Total				\$ 1,321.10
Value Added Services				
TriGreen Secure				
Value Added Services Total				\$ 0.00
Other Charges				
Freight		1	\$ 532.00	\$ 532.00
Other Charges Total				\$ 532.00
Suggested Price				\$ 27,909.10
Customer Discounts				
Customer Discounts Total			\$ -6,949.99	\$ -6,949.99
Total Selling Price				\$ 20,959.11

Tractor bid form:

FACTORY OR DEALER PACKAGE DEAL:

Company: _____ Tractor/model/HP proposed: _____ / _____ / _____

Price delivered complete with installed loader and attachments: \$ _____

In event this tractor is a package deal tractor list all implements above the minimum required specifications listed that are being included as a "bonus package" in the price above:

SPECIAL NOTES: REGARDING FEATURES OF TRACTOR OR IMPLEMENTS THAT "bidder" WOULD LIKE TO NOTE to be CONSIDERED IN the bid:

NON PACKAGE OR IMPLEMENT PRICING

(Only Minimum Bid Specification TRACTOR and equipped as specified with loader, mower, quick detach offerings.)

Company: TriGreen Equipment Tractor/model/HP proposed: John Deere / 4044M / 44 HP
\$ 26,780.79 price is complete with all attachments installed and delivered.

Tractor base price \$ 26,396.89

For just the Tractor/ Loader installed /turf tires priced only: 26,396.89

Clarifications in

notes: Loaders are Factory installed that is why price does not change much.

For additional multiple models and priced tractors to be proposed, print, complete and attach additional sheets of this form to back. (All questions may be directed to Mike Plunkett 931-306-7401 (cell))

Implements Not specified in the bid, but being offered at special \$ discount pricing below to schools for Athletic Sports teams in event they wish to use this bid during its deadline duration of 12 months from the date of bid award.

Implement offered

minimum HP to use:

Normally Priced

Special pricing:

LMC spreader / 16 HP / 835.62 / 696.51

5ft grooming mower 20 HP / 3750.91 / 3,205.62

3 pt. sprayer / 25 HP / 1950.00 / 1,675.42

_____ / _____ / _____ / _____



JOHN DEERE

Quote Id: 21666941

21 April 2020

Hickman County Schools Hickman County High School
1645 Bulldog Blvd
Centerville, TN 37033

Thank you for allowing TriGreen Equipment to quote your equipment needs. TriGreen is committed to providing affordable property solutions for the farm, home, and worksite.

John Deere quality and reliability is unsurpassed when backed by TriGreen sales, parts, and service support. To enhance your ownership experience TriGreen is proud to offer our exclusive Encore Performance Programs which allows you to prepay your annual maintenance, extend factory warranty, and help control total cost of ownership.

Thank you for the opportunity to be your equipment solutions provider.

Patrick Perry
615-229-2400
TriGreen Equipment LLC



Quote Summary

Prepared For:

Hickman County Schools Hickman County High School
1645 Bulldog Blvd
Centerville, TN 37033

Prepared By:

Patrick Perry
TriGreen Equipment LLC
707 Henslee Drive
Dickson, TN 37055
Phone: 615-229-2400
patrickperry@trigreen.com

Quote Id: 21666941
Created On: 21 April 2020
Last Modified On: 01 May 2020
Expiration Date: 31 May 2020

Equipment Summary	Suggested List	Selling Price	Qty	Extended
JOHN DEERE 4044M Compact Utility Tractor (33 PTO hp) TriGreen Secure	\$ 36,338.90	\$ 26,780.79 X	1 =	\$ 26,780.79
	Pay As You Go			
Equipment Total				\$ 26,780.79

Quote Summary

Equipment Total	\$ 26,780.79
SubTotal	\$ 26,780.79
Est. Service Agreement Tax	\$ 0.00
Total	\$ 26,780.79
Down Payment	(0.00)
Rental Applied	(0.00)
Balance Due	\$ 26,780.79

Salesperson : X _____

Accepted By : X _____



JOHN DEERE

Selling Equipment

Quote Id: 21666941

Customer: HICKMAN COUNTY SCHOOLS HICKMAN COUNTY HIGH SCHOOL

JOHN DEERE 4044M Compact Utility Tractor (33 PTO hp)

Hours:	Suggested List
Stock Number:	\$ 36,338.90

Selling Price
\$ 26,780.79

Code	Description	Qty	Unit	Extended
0319LV	4044M Compact Utility Tractor (33 PTO hp)	1	\$ 28,443.00	\$ 28,443.00

Standard Options - Per Unit

0202	United States	1	\$ 0.00	\$ 0.00
0409	English Operator's Manual and Decal Kit	1	\$ 0.00	\$ 0.00
1520	eHydro™	1	\$ 1,162.00	\$ 1,162.00
1701	Factory Installed Loader with Bucket	1	\$ 6,291.00	\$ 6,291.00
2000	Open Station with Standard Seat	1	\$ 0.00	\$ 0.00
4061	Less iMatch™ Quick Hitch Category 1	1	\$ 0.00	\$ 0.00
5090	Less Wheel Spacer	1	\$ 0.00	\$ 0.00
5243	44x18-20 (4PR, R3 Turf, 1 Position)	1	\$ -485.00	\$ -485.00
6243	27x10.50-15 (4PR, R3 Turf, 2 Position)	1	\$ 0.00	\$ 0.00

Standard Options Total	\$ 6,968.00
-------------------------------	--------------------

Dealer Attachments

LVB25976	iMatch™ Quick-Hitch Category 1 with adjustable top hook	1	\$ 383.90	\$ 383.90
----------	---	---	-----------	-----------

Dealer Attachments Total	\$ 383.90
---------------------------------	------------------

Value Added Services

TriGreen Secure				
Value Added Services Total				\$ 0.00

Other Charges

Freight		1	\$ 544.00	\$ 544.00
Other Charges Total				\$ 544.00

Suggested Price	\$ 36,338.90
------------------------	---------------------

Customer Discounts

Customer Discounts Total	\$ -9,558.11	\$ -9,558.11
---------------------------------	---------------------	---------------------

Total Selling Price	\$ 26,780.79
----------------------------	---------------------

Invitation to Bid

The Hickman County Finance Office is accepting bids for "School Painting contract 2020-2023".

This bid is a 3-year bid, with a year to year contract. Bidders must comply with all Federal, State and Local laws and regulations regarding employees working on school grounds (i.e., background checks).

For additional information, contact the Maintenance Office, at 931-729-3391 Ext. 3.

Part B specifications are also available online at: www.hickmank12.org/request-for-proposal.

Sealed bids must be mailed to the Hickman County Finance Office, 114 North Central Avenue, Suite 203, Centerville, TN 37033 and clearly marked on the outside of the envelope "School Painting".

Bids will be opened on Monday, May 4, 2020 at 10:15 a.m. in the Finance Office.

The Hickman County Board of Education reserves the right to accept or reject any and all bids or parts of bids and to waive any informalities that would prevent the acceptance of a better bid.

Bids Rec.

No Bids Rec

Present
C. Fitzgerald
Caroli Davis

Invitation To Bid

The Hickman County Finance Office will be accepting sealed bids for Multi-Year Annual HVAC Service, Repair and Installations at Hickman County Schools.

All sealed bids must be hand delivered or mailed to Hickman County Finance Office, 114 North Central Avenue, Centerville TN 37033 and clearly marked "Annual HVAC Service, Repair and Installation" on the outside of the bid mailing envelope. Bids will be opened on Monday, May 4, 2020 at 10:30 a.m.

Part B specifications can be found online at www.hickmank12.org/request-for-proposal or by contacting the Hickman County Finance Office at 931-729-3391 Ext. 3.

Hickman County Board of Education reserves the right to accept or reject any bids and or parts of bids and to waive any informalities that would prevent its acceptance of a better bid.

Present
Caroli Davis
C. Fitzmaurice

Comfort Systems USA = ¹⁵ see attached bids
S.M. Lawrence

TN Elite Mechanical = (see attached bids

Part B Specs:

Main Specifications and Bid Sheet HVAC

Qualification:

Bidders must demonstrate references as such, with a history in large buildings such as schools, hospitals, and or Big box stores of 150000 sq. ft. facilities or larger. Must be able to respond to School repair needs within 24 hours of a call, as our school operations must be kept tempered and comfortable learning environment must be maintained.

All bidders must be licensed HVAC commercial repair. All bidders must “attach” a certificate of business insurance with coverage liability of 1 million, workers compensation, TN business license, and the TN HVAC “license number” registered with the State of TN with the bid. Bidders must meet all local, state, and federal regulations in regard to employees working on school properties and comply with TCA 49-5-406 regard to working on state school properties, and provide an annual affidavit that background checks and drug testing have been completed on all employees that will be working on school properties.

Awarded bidder must perform said work and subs will not be permitted without the prior approval of the maintenance director or Hickman county school district.

General Scope of work:

Scope: This is a 3 year bid with annual contract and shall be good from July 1 2020 – June 30, 2023 the bid will end on June 30, 2023 for rebidding. The contract will be presented for signing each April and no later than May 1.

****Either party may withdraw at any time from the bid year by notifying other party in writing with a 45 day notice prior to the beginning of school year. Prices and rates must remain fixed during the three year contract.**

The bid is for labor, material and the servicing/repair and installation of equipment for all any county building deemed needed by the school maintenance director within the school district.

For Installations of replacement equipment:

In event a unit is condemned and approved for replacement, said equipment may/or will be purchased by the school system and the bidder will be asked to install and startup said equipment per the manufacture requirements to maintain warranties.

The school system further reserves the right to install said equipment when necessary, on its own or to seek out competitive project quotes when receiving estimates from awarded bidder without being obligated to the awarded bidder to install unless awarded bidder is available and is the lower of the estimates. Payments are to be based on actual time involved at the below bided hourly rates, materials, equipment required and not the estimated amount. (Estimates are purely for budgetary decisions to proceed and are likely higher that actual costs.)

Alt #1: (fill in bid form and submit attached to your bid; items below as described:)

Service Trip charges \$ 25.00 (NOTE: Only one trip charge per day will be permitted to our county as there are or may be multiple locations with service requests or units in county to be serviced.)

Equipment rental charges such as cranes, booms, lifts if not provided by School district will be billed at % of mark up \$ 15% (Note: Actual copy of rental invoice must be submitted with invoices.)

Materials/parts- plus mark- up % 25% (Note: TN State suggested maximum bid is set at 15%)

(Note: Any parts provided must have the copy of original parts invoice demonstrating cost /plus mark-up)

Freon Charges LB. \$ 40.00 (R22) \$ 30.00 (410A)

Flat EPA charge \$ 15.00

Flat recovery/Vacuum Charge \$ 50.00

Flat Per/Hour labor Charge per authorized tech \$ 85.00

Flat General Labor Helper Per/hour charge \$ 65.00

(Lower Skill set, Coil washer Per/Hour \$ 65.00

Alt #3: Annual Summer servicing:

Alt #1

Annual coils/ Filter servicing all 9- main buildings (8 being schools): \$ 29,655.00 total with filters and belts.

*2% escalation
Per year
VK*

Alt #2

**Annual coils/Filter servicing all 9 main buildings only: \$ 23,265.00 total "with School furnished filters and belts" furnished by the School District maintenance TEAM and staged in the building of each location as needed on the scheduled plan of work provided to Maintenance Director, by the awarded bidder.

*2% escalation
Per year
VK*

Schedule of equipment being serviced on the Annual summer servicing:

462 HVAC units: assorted RTU/ Air Handlers/ PTAC units

2 cooling towers (HCMS/EHMS)

10 -boiler units (2- CIS, 2- HCMS, 1 EHHS (kitchen), 2-CIS, 1-EHMS, 2-EHIS)

10-loop pumps (2- Geo-EHIS, 2-Geo-CIS, 2-loop- HCMS, 2-loop- EHMS)

For questions, to obtain a copy of the Part B Specs or facility access, contact the Maintenance Director at 931-729-3391 Ext. 3.

****Note: Crane or equipment rental to be discussed and quoted to maintenance director prior to use if needed to insure total expenses will be calculated prior to authorization to proceed. Hickman County schools reserves the right to also arrange their own crane crew or bucket truck on any job they desire.**

Annual Coil/filter Servicing/unit run tests:

The scope of this bid requires that all units are annual serviced beginning May 25th, and shall be completed by July 25 with annual dated annual services tags on them.

Tech Helper: Per hourly rate \$ 65.00

Clean and service coils, date and swap filters, log units as completed check marked as done, ensure all door panels are fastened with all screws and handles as to not have rain or water into units. Verify each disconnect is turned back on upon completion.

Coil Washer/ helper:

****Note: Typically this work can be done with lower skill set but with supervision of a full technician and will not billed as full tech rates.**

Specify per hourly rate or per unit rate: \$ 65.00

Full Technician: To work behind the coil service Helpers in a supervisory capacity to insure units are not damaged, and each to be pressure checked and run tested to insure no mechanical needs are not noted and addressed.

Fully trained HVAC tech hourly rate: \$ 85.00

Upon a critical Repair noted:

When a critical RED area is noted that the unit is not in running operational condition, said tech will immediately notify the maintenance office or maintenance director and provide the unit information, problem with the unit via phone, for possible on spot approval to complete repair. It will be at the discretion of the Maintenance Director to request a quote or proceed with repair depending upon a major or minor cost issue.

Reports log to be provided by school:

Units log reports are completed at each location; listing by school, RTU/room number/brand/ SL and model number/ and any issues noted on the check-out of possible repair needed. Listing is to be ranked for each unit by Color code as: Green/ in working order no action needed/ repair is: red/ critical, orange / will need addressing within next 12 month/ and yellow- nominal wear at this time good.

A service sticker is to be on every unit in a viewable location certifying unit has be checked and serviced with date, initials of tech, or an annual color sticker for that year.



ADDITIONAL REMARKS SCHEDULE

AGENCY USI Southwest		NAMED INSURED SM Lawrence Company Inc. 1330 Murfreesboro Pike Nashville, TN 37217	
POLICY NUMBER			
CARRIER	NAIC CODE	EFFECTIVE DATE:	

ADDITIONAL REMARKS

THIS ADDITIONAL REMARKS FORM IS A SCHEDULE TO ACORD FORM,
FORM NUMBER: 25 FORM TITLE: CERTIFICATE OF LIABILITY INSURANCE

Per Statute
 E.L. Each Accident \$7,000,000
 E.L. Disease Ea Employee \$7,000,000
 E.L. Disease Policy Limit \$7,000,000

WC020608515 Effective 11/01/2019-11/01/2020
 Illinois National Insurance Co. NAICS 23817
 FL

Per Statute
 E.L. Each Accident \$7,000,000
 E.L. Disease Ea Employee \$7,000,000
 E.L. Disease Policy Limit \$7,000,000

WC020608563 Effective 11/01/2019-11/01/2020
 The Insurance Company of the State of Pennsylvania NAICS 19429
 CO

Per Statute
 E.L. Each Accident \$7,000,000
 E.L. Disease Ea Employee \$7,000,000
 E.L. Disease Policy Limit \$7,000,000

State of Tennessee

34247 0961333

BOARD FOR LICENSING CONTRACTORS

CONTRACTOR

S. M. LAWRENCE COMPANY, INC.

This is to certify that all requirements of the State of Tennessee have been met.

ID NUMBER: 13804

LIC STATUS: ACTIVE

EXPIRATION DATE: February 29, 2020

AGLM UNLIMITED; BC ; CE ; CMC ; HRA ; MU ; S-Medical Gas



IN-1313

DEPARTMENT OF
COMMERCE AND INSURANCE

Metropolitan Government of Nashville
& Davidson County

Certificate
No.

JC328

BOARD OF PLUMBING EXAMINERS AND APPEALS

Receipt
No.

1719285

This is to Certify that

S. M. LAWRENCE COMPANY INC
245 PRESTON STREET
JACKSON, TN 38301

HAS BEEN DULY EXAMINED AND REGISTERED
AS A

STATE PLUMBING CONTRACTOR

MAYOR DAVID BRILEY

CHAIRMAN

EXPIRATION DATE 12/31/2019

DIRECTOR DEPARTMENT OF
CODES ADMINISTRATION

FRANK SULLIVAN, CHAIRMAN

BILL HERBERT

Metropolitan Government of Nashville & Davidson County
Board of

FOR INSPECTION CALL:

PLUMBING EXAMINERS AND APPEALS

STATE PLUMBING CONTRACTOR (615) 862-6570

Certificate
No.

JC328

Receipt
No.

1719285

This is to Certify that

S. M. LAWRENCE COMPANY INC

HAS BEEN DULY EXAMINED AND REGISTERED
AS A

STATE PLUMBING CONTRACTOR

EXPIRES 12/31/2019 S. M. LAWRENCE COMPANY INC

Metropolitan Government of Nashville & Davidson County

Certificate No.

JC328

Receipt No.

1719285

Receipt for Professional License

RENEWAL

STATE PLUMBING CONTRACTOR

S. M. LAWRENCE COMPANY INC
245 PRESTON STREET
JACKSON, TN 38301

FEE RECEIVED \$100.00

DIRECTOR
DEPARTMENT OF CODES ADMINISTRATION
BILL HERBERT

EFFECTIVE DATE 09/11/2006
EXPIRATION DATE 12/31/2019



CERTIFICATE OF RECOGNITION

The United States Department of Labor recognizes

S.M. Lawrence Company, Inc.

for participating in the OSHA
**2017 National Safety Stand-Down
to Prevent Falls in Construction**



Safety Pays. Falls Cost.

Dean McKenzie
Dean McKenzie, Director
Directorate of Construction



Part B Specs:

Main Specifications and Bid Sheet HVAC

Qualification:

Bidders must demonstrate references as such, with a history in large buildings such as schools, hospitals, and or Big box stores of 150000 sq. ft. facilities or larger. Must be able to respond to School repair needs within 24 hours of a call, as our school operations must be kept tempered and comfortable learning environment must be maintained.

All bidders must be licensed HVAC commercial repair. All bidders must "attach" a certificate of business insurance with coverage liability of 1 million, workers compensation, TN business license, and the TN HVAC "license number" registered with the State of TN with the bid. Bidders must meet all local, state, and federal regulations in regard to employees working on school properties and comply with TCA 49-5-406 regard to working on state school properties, and provide an annual affidavit that background checks and drug testing have been completed on all employees that will be working on school properties.

Awarded bidder must perform said work and subs will not be permitted without the prior approval of the maintenance director or Hickman county school district.

General Scope of work:

Scope: This is a 3 year bid with annual contract and shall be good from July 1 2020 – June 30, 2023 the bid will end on June 30, 2023 for rebidding. The contract will be presented for signing each April and no later than May 1.

****Either party may withdraw at any time from the bid year by notifying other party in writing with a 45 day notice prior to the beginning of school year. Prices and rates must remain fixed during the three year contract.**

The bid is for labor, material and the servicing/repair and installation of equipment for all any county building deemed needed by the school maintenance director within the school district.

For Installations of replacement equipment:

In event a unit is condemned and approved for replacement, said equipment may/or will be purchased by the school system and the bidder will be asked to install and startup said equipment per the manufacture requirements to maintain warranties.

The school system further reserves the right to install said equipment when necessary, on its own or to seek out competitive project quotes when receiving estimates from awarded bidder without being obligated to the awarded bidder to install unless awarded bidder is available and is the lower of the estimates. Payments are to be based on actual time involved at the below bided hourly rates, materials, equipment required and not the estimated amount. (Estimates are purely for budgetary decisions to proceed and are likely higher that actual costs.)

****Note: Crane or equipment rental to be discussed and quoted to maintenance director prior to use if needed to insure total expenses will be calculated prior to authorization to proceed. Hickman County schools reserves the right to also arrange their own crane crew or bucket truck on any job they desire.**

Annual Coil/filter Servicing/unit run tests:

The scope of this bid requires that all units are annual serviced beginning May 25th, and shall be completed by July 25 with annual dated annual services tags on them.

Tech Helper: Per hourly rate \$ 58.00

Clean and service coils, date and swap filters, log units as completed check marked as done, ensure all door panels are fastened with all screws and handles as to not have rain or water into units. Verify each disconnect is turned back on upon completion.

Coil Washer/ helper:

****Note: Typically this work can be done with lower skill set but with supervision of a full technician and will not billed as full tech rates.**

Specify per hourly rate or per unit rate: \$ 58.00

Full Technician: To work behind the coil service Helpers in a supervisory capacity to insure units are not damaged, and each to be pressure checked and run tested to insure no mechanical needs are not noted and addressed.

Fully trained HVAC tech hourly rate: \$ 78.00

Upon a critical Repair noted:

When a critical RED area is noted that the unit is not in running operational condition, said tech will immediately notify the maintenance office or maintenance director and provide the unit information, problem with the unit via phone, for possible on spot approval to complete repair. It will be at the discretion of the Maintenance Director to request a quote or proceed with repair depending upon a major or minor cost issue.

Reports log to be provided by school:

Units log reports are completed at each location; listing by school, RTU/room number/brand/ SL and model number/ and any issues noted on the check-out of possible repair needed. Listing is to be ranked for each unit by Color code as: Green/ in working order no action needed/ repair is: red/ critical, orange / will need addressing within next 12 month/ and yellow- nominal wear at this time good.

A service sticker is to be on every unit in a viewable location certifying unit has be checked and serviced with date, initials of tech, or an annual color sticker for that year.

Alt #1: (fill in bid form and submit attached to your bid; items below as described:)

Service Trip charges \$ 20.00 (**NOTE:** Only one trip charge per day will be permitted to our county as there are or may be multiple locations with service requests or units in county to be serviced.)

Equipment rental charges such as cranes, booms, lifts if not provided by School district will be billed at % of mark up \$ 15% (Note: Actual copy of rental invoice must be submitted with invoices.)

Materials/parts- plus mark- up % 15% (Note: TN State suggested maximum bid is set at 15%)

(Note: Any parts provided must have the copy of original parts invoice demonstrating cost /plus mark-up)

Freon Charges LB. \$ 75.00 (R22) \$ 20.00 (410A)

Flat EPA charge \$ 0

Flat recovery/Vacuum Charge \$ 35.00/20.00

Flat Per/Hour labor Charge per authorized tech \$ 78.00

Flat General Labor Helper Per/hour charge \$ 58.00

(Lower Skill set, Coil washer Per/Hour \$ 58.00

Alt #3: Annual Summer servicing:

Alt #1

Annual coils/ Filter servicing all 9- main buildings (8 being schools): \$ 28,233 total with filters and belts.

Alt #2

****Annual coils/Filter servicing all 9 main buildings only: \$ 22,173 total " with School furnished filters and belts" furnished by the School District maintenance TEAM and staged in the building of each location as needed on the scheduled plan of work provided to Maintenance Director, by the awarded bidder.**

Schedule of equipment being serviced on the Annual summer servicing:

462 HVAC units: assorted RTU/ Air Handlers/ PTAC units

2 cooling towers (HCMS/EHMS)

10 -boiler units (2- CIS, 2- HCMS, 1 EHHS (kitchen), 2-CIS, 1-EHMS, 2-EHIS)

10-loop pumps (2- Geo-EHIS, 2-Geo-CIS, 2-loop- HCMS, 2-loop- EHMS)

For questions, to obtain a copy of the Part B Specs or facility access, contact the Maintenance Director at 931-729-3391 Ext. 3.



**Hickman County
Business Tax Standard License**

April 22, 2019

DAVID CROWNOVER
TENNESSEE ELITE MECHANICAL, LLC
9024 URUBAMBA DR
LYLES TN 37098-1964

Letter ID: L1894967552
Expiration Date: 15-May-2020
Return Due By: 15-Apr-2020

The business tax license printed below certifies the receipt and approval of your business tax license application or the renewal of a license for your existing business. The license is valid until the expiration date noted above. Your license number is 1000347776 and your classification is 1B. The certificate must be displayed publicly at the location for which it is issued.

All business tax returns are required to be filed and the payment remitted electronically. Your return is due on April 15, 2020. Please visit www.tn.gov/revenue for additional information.

Note: This license does not permit operation unless properly zoned and/or in compliance with all other applicable state, county, or city laws, rules and regulations. Also, as required by Tenn. Code Ann. § 39-17-1801 et seq., businesses must comply with all provisions of the Tennessee Non-Smoker Protection Act.

DETACH LICENSE BELOW AND DISPLAY IN PUBLIC AREA



**Hickman County
Business Tax Standard License**

This certificate must be publicly displayed.

TENNESSEE ELITE MECHANICAL, LLC
9024 URUBAMBA DR
LYLES TN 37098-1964



Date Issued: 22-Apr-2019
Classification: 1B
Letter ID: L1894967552
License Number: 1000347776
Expiration Date: 15-May-2020



CERTIFICATE OF LIABILITY INSURANCE

DATE (MM/DD/YYYY)

04/29/2020

THIS CERTIFICATE IS ISSUED AS A MATTER OF INFORMATION ONLY AND CONFERS NO RIGHTS UPON THE CERTIFICATE HOLDER. THIS CERTIFICATE DOES NOT AFFIRMATIVELY OR NEGATIVELY AMEND, EXTEND OR ALTER THE COVERAGE AFFORDED BY THE POLICIES BELOW. THIS CERTIFICATE OF INSURANCE DOES NOT CONSTITUTE A CONTRACT BETWEEN THE ISSUING INSURER(S), AUTHORIZED REPRESENTATIVE OR PRODUCER, AND THE CERTIFICATE HOLDER.

IMPORTANT: If the certificate holder is an ADDITIONAL INSURED, the policy(ies) must have ADDITIONAL INSURED provisions or be endorsed. If SUBROGATION IS WAIVED, subject to the terms and conditions of the policy, certain policies may require an endorsement. A statement on this certificate does not confer rights to the certificate holder in lieu of such endorsement(s).

PRODUCER Brown & Brown of Tennessee, Inc. dba Spann Insurance 6 Cadillac Drive, Suite 200 Brentwood TN 37027	CONTACT NAME: Casey Morphis PHONE (A/C, No, Ext): (615) 383-8000 FAX (A/C, No): (615) 385-8360 E-MAIL ADDRESS: cmorphis@bbtennessee.com																				
	<table border="1"> <tr> <th colspan="2">INSURER(S) AFFORDING COVERAGE</th> <th>NAIC #</th> </tr> <tr> <td>INSURER A :</td> <td>Main Street America Assurance Company</td> <td>29939</td> </tr> <tr> <td>INSURER B :</td> <td>NGM Insurance Company</td> <td>14788</td> </tr> <tr> <td>INSURER C :</td> <td>MidSouth Mutual Insurance Company</td> <td>12839</td> </tr> <tr> <td>INSURER D :</td> <td></td> <td></td> </tr> <tr> <td>INSURER E :</td> <td></td> <td></td> </tr> <tr> <td>INSURER F :</td> <td></td> <td></td> </tr> </table>	INSURER(S) AFFORDING COVERAGE		NAIC #	INSURER A :	Main Street America Assurance Company	29939	INSURER B :	NGM Insurance Company	14788	INSURER C :	MidSouth Mutual Insurance Company	12839	INSURER D :			INSURER E :			INSURER F :	
INSURER(S) AFFORDING COVERAGE		NAIC #																			
INSURER A :	Main Street America Assurance Company	29939																			
INSURER B :	NGM Insurance Company	14788																			
INSURER C :	MidSouth Mutual Insurance Company	12839																			
INSURER D :																					
INSURER E :																					
INSURER F :																					
INSURED TENNESSEE ELITE MECHANICAL LLC 9024 URUBAMBA DR LYLES TN 37098-1964																					

COVERAGES **CERTIFICATE NUMBER:** 19/20 MASTER **REVISION NUMBER:**

THIS IS TO CERTIFY THAT THE POLICIES OF INSURANCE LISTED BELOW HAVE BEEN ISSUED TO THE INSURED NAMED ABOVE FOR THE POLICY PERIOD INDICATED. NOTWITHSTANDING ANY REQUIREMENT, TERM OR CONDITION OF ANY CONTRACT OR OTHER DOCUMENT WITH RESPECT TO WHICH THIS CERTIFICATE MAY BE ISSUED OR MAY PERTAIN, THE INSURANCE AFFORDED BY THE POLICIES DESCRIBED HEREIN IS SUBJECT TO ALL THE TERMS, EXCLUSIONS AND CONDITIONS OF SUCH POLICIES. LIMITS SHOWN MAY HAVE BEEN REDUCED BY PAID CLAIMS.

INSR LTR	TYPE OF INSURANCE	ADDL INSD	SUBR WVD	POLICY NUMBER	POLICY EFF (MM/DD/YYYY)	POLICY EXP (MM/DD/YYYY)	LIMITS
A	<input checked="" type="checkbox"/> COMMERCIAL GENERAL LIABILITY <input type="checkbox"/> CLAIMS-MADE <input checked="" type="checkbox"/> OCCUR GEN'L AGGREGATE LIMIT APPLIES PER: <input type="checkbox"/> POLICY <input checked="" type="checkbox"/> PROJECT <input type="checkbox"/> LOC OTHER:			MPG1933L	11/14/2019	11/14/2020	EACH OCCURRENCE \$ 2,000,000 DAMAGE TO RENTED PREMISES (Ea occurrence) \$ 500,000 MED EXP (Any one person) \$ 10,000 PERSONAL & ADV INJURY \$ 2,000,000 GENERAL AGGREGATE \$ 4,000,000 PRODUCTS - COMP/OP AGG \$ 4,000,000 Identity Recovery Cov \$ 25,000
A	AUTOMOBILE LIABILITY <input type="checkbox"/> ANY AUTO <input type="checkbox"/> OWNED AUTOS ONLY <input type="checkbox"/> SCHEDULED AUTOS <input checked="" type="checkbox"/> HIRED AUTOS ONLY <input checked="" type="checkbox"/> NON-OWNED AUTOS ONLY			MPG1933L	11/14/2019	11/14/2020	COMBINED SINGLE LIMIT (Ea accident) \$ BODILY INJURY (Per person) \$ 2,000,000 BODILY INJURY (Per accident) \$ PROPERTY DAMAGE (Per accident) \$ \$
B	<input checked="" type="checkbox"/> UMBRELLA LIAB <input type="checkbox"/> EXCESS LIAB OCCUR CLAIMS-MADE DED RETENTION \$			CUG1933L	11/14/2019	11/14/2020	EACH OCCURRENCE \$ 5,000,000 AGGREGATE \$ 5,000,000 \$ <input checked="" type="checkbox"/> PER STATUTE <input type="checkbox"/> OTH-ER
C	WORKERS COMPENSATION AND EMPLOYERS' LIABILITY ANY PROPRIETOR/PARTNER/EXECUTIVE OFFICER/MEMBER EXCLUDED? (Mandatory in NH) If yes, describe under DESCRIPTION OF OPERATIONS below	Y/N	N/A	WC04518-2019	06/02/2019	06/02/2020	E.L. EACH ACCIDENT \$ 1,000,000 E.L. DISEASE - EA EMPLOYEE \$ 1,000,000 E.L. DISEASE - POLICY LIMIT \$ 1,000,000

DESCRIPTION OF OPERATIONS / LOCATIONS / VEHICLES (ACORD 101, Additional Remarks Schedule, may be attached if more space is required)

CERTIFICATE HOLDER**CANCELLATION**

Hickman County Government 114 N. Central Ave Centerville TN 37033	SHOULD ANY OF THE ABOVE DESCRIBED POLICIES BE CANCELLED BEFORE THE EXPIRATION DATE THEREOF, NOTICE WILL BE DELIVERED IN ACCORDANCE WITH THE POLICY PROVISIONS. AUTHORIZED REPRESENTATIVE 
---	--

© 1988-2015 ACORD CORPORATION. All rights reserved.



STATE OF TENNESSEE
DEPARTMENT OF
COMMERCE AND INSURANCE



TENNESSEE ELITE MECHANICAL, LLC

358942

ID NUMBER: 68509
LIC STATUS: ACTIVE
EXPIRATION DATE: January 31, 2021

BOARD FOR LICENSING CONTRACTORS
CONTRACTOR

THIS IS TO CERTIFY THAT ALL REQUIREMENTS
OF THE STATE OF TENNESSEE HAVE BEEN MET

Attn: DAVID CROWNOVER
TENNESSEE ELITE MECHANICAL, LLC
9024 URUBAMBA DR
LYLES, TN 37098

State of Tennessee

358942

BOARD FOR LICENSING CONTRACTORS

CONTRACTOR

TENNESSEE ELITE MECHANICAL, LLC

This is to certify that all requirements of the State of Tennessee have been met.

ID NUMBER: 68509
LIC STATUS: ACTIVE
EXPIRATION DATE: January 31, 2021
\$3,000,000; CMC



IN-1313
DEPARTMENT OF
COMMERCE AND INSURANCE



**Tennessee
Elite
Mechanical**

(615) 375-1772

Dickson, TN

admin@tnelitemechanical.com

TN CMC 68509
Exp. 01/31/21

Metro Gas-Mech VC1016
Exp. 09/30/2020

Metro Plumbing JC767
Exp. 12/31/2020

REFERENCES

- WILLIAMSON COUNTY SCHOOLS – Tracy England, Facilities Maintenance Director. 615-472-4976. tracye@wcs.edu
- METRO NASHVILLE PUBLIC SCHOOLS – Zach Moore, Project Manager. 615-922-3020. Zachary.moore@mnps.org
- VANDERBILT UNIVERSITY MEDICAL CENTER – George Thompkins, HAR Manager. 615-636-6638. George.m.thompkins@vanderbilt.edu
- Ensworth High School – Andrew Smith, Facilities Director. 615-934-9898. smitha@ensworth.com
- Diocese of Nashville – Paul Netter, Facilities Director. 615-456-0368. Paul.netter@dioceseofnashville.com
- Hickman County Schools – Mike Plunkett, Maintenance Director. Mike.plunkett@hickmank12.org



24/7/365 Service Coverage

Expert Installation, Service & Repair

HVAC

- **1-3000 tons**
- **Preventative Maintenance**
- **Electronic Service Tracking**
- **Chillers**
- **MRI Chillers**
- **Boilers**
- **Certified Installation,
Service, Repairs**
 - **Lochinvar**
 - **LAARS**
 - **Fulton**

MECHANICAL

- **Pumps**
- **Cooling Towers**
- **Heat Exchangers**
- **Mechanical Piping**
 - **Pressed**
 - **MIG**
 - **TIG**
 - **Stick**
 - **Fused**
 - **Threaded**
 - **Grooved**
- **Pipe Freezing**
- **Sanitary Food Grade Piping**
- **Hot Tapping**
- **Hydronics**

REFRIGERATION

- **Walk-In Coolers and Freezers**
- **Reach-In Coolers and Freezers**
- **Ice Machines**

PLUMBING

- **Water Heaters**
- **Backflow Prevention**
- **Service Plumbing**

CONTROLS

- **Variable Speed Drives**
- **Authorized Contractor For:**
 - **ABB**
- **Controls**
 - **DDC Stand Alone**
 - **Pneumatic**

MISCELLANEOUS

- **Sheet Metal**
- **Insulation**
- **ASSE 6010 & 6040 Medical Gas**

 **AIA**® Document A305™ – 1986

Contractor's Qualification Statement

The Undersigned certifies under oath that the information provided herein is true and sufficiently complete so as not to be misleading.

SUBMITTED TO:
HICKMAN COUNTY SCHOOLS

ADDRESS: HICKMAN COUNTY SCHOOLS
114 NORTH CENTRAL AVE.,
CENTERVILLE, TN 37033

SUBMITTED BY:
TENNESSEE ELITE MECHANICAL LLC

NAME:
DAVID CROWNOVER

ADDRESS:
9024 URUBAMBA DRIVE
LYLES, TN 37098

PRINCIPAL OFFICE:
DICKSON, TN

- Corporation
- Partnership
- Individual
- Joint Venture
- Other

NAME OF PROJECT (if applicable):
RFB# 1207 BOILER REPLACEMENTS AT EDMONDSON, GRASSLAND, HUNTERS BEND,
LIPSCOMB, OAK VIEW, AND WINSTEAD ELEMENTARY SCHOOLS

TYPE OF WORK (file separate form for each Classification of Work):

- General Construction
- HVAC
- Electrical
- Plumbing
- Other (please specify)

ADDITIONS AND DELETIONS:
The author of this document has added information needed for its completion. The author may also have revised the text of the original AIA standard form. An *Additions and Deletions Report* that notes added information as well as revisions to the standard form text is available from the author and should be reviewed. A vertical line in the left margin of this document indicates where the author has added necessary information and where the author has added to or deleted from the original AIA text.

This document has important legal consequences. Consultation with an attorney is encouraged with respect to its completion or modification.

This form is approved and recommended by the American Institute of Architects (AIA) and The Associated General Contractors of America (AGC) for use in evaluating the qualifications of contractors. No endorsement of the submitting party or verification of the information is made by AIA or AGC.

§ 1. ORGANIZATION

§ 1.1 How many years has your organization been in business as a Contractor?

5 YEARS

§ 1.2 How many years has your organization been in business under its present business name?

5 YEARS

§ 1.2.1 Under what other or former names has your organization operated?

N/A

§ 1.3 If your organization is a corporation, answer the following:

§ 1.3.1 Date of incorporation:

§ 1.3.2 State of incorporation:

§ 1.3.3 President's name:

§ 1.3.4 Vice-president's name(s)

§ 1.3.5 Secretary's name:

§ 1.3.6 Treasurer's name:

§ 1.4 If your organization is a partnership, answer the following:

§ 1.4.1 Date of organization:

§ 1.4.2 Type of partnership (if applicable):

§ 1.4.3 Name(s) of general partner(s)

§ 1.5 If your organization is individually owned, answer the following:

§ 1.5.1 Date of organization:

01/01/2015

§ 1.5.2 Name of owner:
DAVID CHARLES CROWNOVER

§ 1.6 If the form of your organization is other than those listed above, describe it and name the principals:
LIMITED LIABILITY COMPANY
MANAGING MEMBER / OWNER: DAVID CROWNOVER

§ 2. LICENSING

§ 2.1 List jurisdictions and trade categories in which your organization is legally qualified to do business, and indicate registration or license numbers, if applicable.

MECHANICAL CONTRACTING

STATE OF TENNESSEE
BOARD FOR LICENSING CONTRACTORS
CMC LIC # 68509

§ 2.2 List jurisdictions in which your organization's partnership or trade name is filed.
STATE OF TENNESSEE

§ 3. EXPERIENCE

§ 3.1 List the categories of work that your organization normally performs with its own forces.

INSTALLATION, SERVICE, REPAIRS, MAINTENANCE OF:
HVAC, CHILLERS, BOILERS
MECHANICAL, PUMPS COOLING TOWERS, HEAT EXCHANGERS, MECHANICAL PIPING,
PIPE FREEZING, SANITARY FOOD GRADE PIPING, HOT TAPPING, HYDRONICS
REFRIGERATION, WALK IN OR REACH IN COOLERS / FREEZERS, ICE MACHINES
CONTROLS: VARIABLE SPEED DRIVES, DDC STAND ALONE, PNEUMATIC
SHEET METAL, INSULATION, MEDICAL GAS

§ 3.2 Claims and Suits. (If the answer to any of the questions below is yes, please attach details.)

§ 3.2.1 Has your organization ever failed to complete any work awarded to it?
NO

§ 3.2.2 Are there any judgments, claims, arbitration proceedings or suits pending or outstanding against your organization or its officers?
NO

§ 3.2.3 Has your organization filed any law suits or requested arbitration with regard to construction contracts within the last five years?

NO

§ 3.3 Within the last five years, has any officer or principal of your organization ever been an officer or principal of another organization when it failed to complete a construction contract? (If the answer is yes, please attach details.)

NO

§ 3.4 On a separate sheet, list major construction projects your organization has in progress, giving the name of project, owner, architect, contract amount, percent complete and scheduled completion date.

§ 3.4.1 State total worth of work in progress and under contract:

§ 3.5 On a separate sheet, list the major projects your organization has completed in the past five years, giving the name of project, owner, architect, contract amount, date of completion and percentage of the cost of the work performed with your own forces.

§ 3.5.1 State average annual amount of construction work performed during the past five years:

5 YEAR AVERAGE: \$970,544

§ 3.6 On a separate sheet, list the construction experience and present commitments of the key individuals of your organization.

§ 4. REFERENCES

§ 4.1 Trade References:

NASHVILLE SHEET METAL, DARRYL UNDERWOOD (615)708-2661 darrylu@nashvillesheetmetal.com
FERGUSONS, TREY HORNE (615)316-1800 trey.horne@ferguson.com
EDS SUPPLY, FRED RODGERS (615)242-4345 frodgers@edssupply.com
HOBBS AND ASSOCIATES, RICKY ALEXANDER (615)939-1144 ralexander@hobbsassociates.com

§ 4.2 Bank References:

SUNTRUST BANK
7121 HWY 70 S
NASHVILLE, TN 37221
(615) 928-4500

TRISTAR BANK
719 E COLLEGE ST
DICKSON, TN 37055
(615) 446-7100

§ 4.3 Surety:

§ 4.3.1 Name of bonding company:
PENN NATIONAL

§ 4.3.2 Name and address of agent:
MICHELLE ELDRIDGE
BROWN & BROWN OF TENNESSEE, INC.
6 CADILLAC DRIVE, SUITE 200
BRENTWOD, TN 37027

§ 5. FINANCING

§ 5.1 Financial Statement.

§ 5.1.1 Attach a financial statement, preferably audited, including your organization's latest balance sheet and income statement showing the following items:

Current Assets (e.g., cash, joint venture accounts, accounts receivable, notes receivable, accrued income, deposits, materials inventory and prepaid expenses);

Net Fixed Assets;

Other Assets;

Current Liabilities (e.g., accounts payable, notes payable, accrued expenses, provision for income taxes, advances, accrued salaries and accrued payroll taxes);

Other Liabilities (e.g., capital, capital stock, authorized and outstanding shares par values, earned surplus and retained earnings).

§ 5.1.2 Name and address of firm preparing attached financial statement, and date thereof:

ANCHOR FINANCIAL GROUP, LLC
112 SOUTH MAIN STREET
DICKSON, TN 37055

§ 5.1.3 Is the attached financial statement for the identical organization named on page one?
YES

§ 5.1.4 If not, explain the relationship and financial responsibility of the organization whose financial statement is provided (e.g., parent-subsidiary).

§ 5.2 Will the organization whose financial statement is attached act as guarantor of the contract for construction?
YES

§ 6. SIGNATURE

§ 6.1 Dated at this 18th day of March 2020

Name of Organization: Tennessee Elite Mechanical

By: David Crownover



Title: President

§ 6.2

David Crownover being duly sworn deposes and says that the information provided herein is true and sufficiently complete so as not to be misleading.

Subscribed and sworn before me this 28 day of April 2020

Notary Public: Brenda Powers

My Commission Expires: Aug 28, 2023



3.4 List of Major Construction Projects in Progress:

- Vanderbilt University Medical Center PHV Chillers Replacement
 - Michael Gable, (615) 642-4305, mike.gable@vumc.org
 - Contract Amount: \$300,000.00
 - Percent Complete: 25
 - Completion Date: 4/15/2020

- NSM Oliver Fiberglass – Installation of Two 40,000 MUA's
 - Darryl Underwood, (615) 708-2661, darrylu@nashvillesheetmetal.com
 - Contract Amount: \$100,000.00
 - Percent Complete: 50
 - Completion Date: 3/15/2020

- Williamson County Schools – RFB#1180-H – HVAC Repair and Replacement Continuing Maintenance Contract
 - Tracy England, (615) 472-4976, tracye@wcs.edu
 - Architect: Johnson & Bailey Architects P.C.
 - Contract Amount: (Ongoing) \$2,225,809.00

3.4.1 Total Worth of Work in Progress and Under Contract:

- Total Worth of Work in Progress: \$2,625,809.00

3.5 Major Projects Completed in the Past Five Years:

- Metropolitan Nashville Public Schools – Thurgood Marshall Boiler Replacement
 - Zach Moore, (615)922-3020, zachary.moore@mnps.org
 - Architect: OLG Engineering
 - Contract Amount: \$219,000.00
 - Completion Date: 1/31/2020
 - Self-Performance Percentage: 80

- Hickman County Government – East Hickman Middle School Boiler Replacement
 - Mike Plunkett, (931) 729-3391, mike.plunkett@hickmank12.org
 - Contract Amount: \$75,000.00
 - Completion Date: 10/31/2019

DANIEL EUBANKS

Operations Manager

CONTACT

PHONE:
615-879-6420

EMAIL:
Daniel.e@tnelitemechanical.com

HOBBIES

Coaching kids' soccer and basketball.
Hunting and spending time outdoors
with family.

EDUCATION

Hickman County High School

8/1994 – 5/1996

Graduated 6th in class of 254 with honors diploma.

Crystal River High School

8/1992 – 6/1994

Maintained 3.9 GPA while taking honors and AP courses.

WORK EXPERIENCE

TN Elite Mechanical - Operations Manager

4/15/19–present

Overseeing projects, implementing new procedures and streamlining new technology and ideas to increase the company's bottom line.

Demand Mechanical - Senior Project Manager

8/12/12–4/14/19

Oversight of 25 field employees, 2 project managers, and 4 account managers. Estimated, sold, and managed over \$6 million/year in projects.

John Bouchard & Sons - Senior Service Technician

8/12/96–8/12/12

Started out as a plumber pipefitter helper, completed HVAC apprenticeship, lead the HVAC and Plumbing service department as senior service technician.

TRAINING AND CERTIFICATIONS

Professional Project Management – PHC Project Management Essentials. Concord, NH. 06/09/2018.

Steam System Design and Application Seminar – Little Red Schoolhouse Training Seminar. Chicago, IL. 10/2018.

Hot Water Design and Engineering – JMP Training Seminar. Nashville, TN. 04/2017.

Med Gas Installer 6010 Certification. Evergreen Institute. Peachtree, GA. 10/2015.

Laars Boilers Factory Certification – Rochester, NH. 04/2014.

Fulton Factory Certification – Pulaski, NY. 2014.

Lochinvar Factory Certification – Lebanon, TN 2012.

Cross Connection Certification – 2008.

CONTACT

PHONE:
(931) 996-3826

EMAIL:
david.c@tnelite.com

ACCREDITATIONS

Trane
Voyager & Precedent

Lochinvar
Commercial Condensing Boilers
Basic Hydronics

Med Gas
ASSE 6010 Installers,
ASME IX Brazer

REA Service, Inc.
Wattmaster – Orion Controls

Mitsubishi Electric Cooling and
Heating
Field Service

TracPipe
Certification

Honeywell
Advanced Gas Ignition and
Controls

Manitowoc Ice, Inc.
Field Service

ESCO Institute EPA Program
Certification

Board of Regents Benchmark of
Technical Excellence
Air Conditioning

Board of Regents Benchmark of
Technical Excellence
Electrical

Tennessee Board of Regents
HVACR

DAVID CROWNOVER

HVACR & MECHANICAL CONTRACTING BUSINESS OWNER

EDUCATION

Tennessee Technology Center
2002 - 2003
HVACR Technician Certificate Program

WORK EXPERIENCE

Tennessee Elite Mechanical LLC – Owner
01/01/2015 – Current

Oversee day to day business activities
Manage service and project crews
Perform and complete advanced service calls
Ensure project crew efficiency and project completion

Demand Mechanical – HVACR Service Technician
May 2014 – May 2015

Perform and complete service calls
Project completion including:
boiler replacement, water piping, drain piping, water heater
replacement, expansion tank installation, cooling tower piping,
water loop piping, gas piping, etc.

Vanderbilt University Medical Center – HVACR Journeyman
May 2010 – May 2014

Perform and complete service calls on critical equipment and restore
services in sometimes time sensitive situations
Schedule and complete projects including:
ice maker installation, steam piping and trap replacement, hot
water and chilled water loops, chillers, and boilers

National HVAC – HVACR Service Technician
May 2003 – May 2010

Perform and complete service calls
Project completion including:
gas piping, water piping, boiler and chiller piping, equipment
installation, water filtration installation

Invitation to Bid

The Hickman County Finance Office is accepting bids for "Security Doors at HCHS"

Specifications can be found at www.hickmank12.org/request-for-proposal or available by calling 931-729-3391 Ext. 3.

Sealed bids must be mailed or hand delivered to the Hickman County Finance Office, 114 North Central Avenue, Suite 203, Centerville, TN 37033 and clearly marked on the outside of the envelope "Security Doors at HCHS".

Bids will be opened on Monday, May 4, 2020 at 11:00 a.m. in the Finance Office.

The Hickman County Board of Education reserves the right to accept or reject any and all bids or parts of bids and to waive any informalities that would prevent the acceptance of a better bid.

Bids
Waverly Glass = \$ 23,862⁰⁰

Present
Cardi Davis
C. Fitzgerald

WAVERLY GLASS, INC.
104 YOUNG RD • PO BOX 773 • WAVERLY, TN 37185
PH: 931-296-1111 • FAX: 931-296-3321

April 30, 2020

PROPOSAL # 7236

TO: HICKMAN COUNTY BOARD OF EDUCATION
ATTN: MIKE PLUNKETT
RE: PROPOSAL – HCHS STOREFRONT PROJECT

THIS PROPOSAL IS FOR THE FOLLOWING SCOPE OF WORK:

***** Prices are good for 30 days from date of quote *****

Doors

Medium stile with intermediate mutton
10" bottom rail
Concealed leaf heavy duty continuous geared hinge

Framing

To match existing foyer
To be anchored to bar joist system above ceiling grid
Must NOT be anchored to ceiling grid

Hardware

Equal to Yale, Sargent
Grade 1 panic devices
Closers Sargent grade 1
Electric latch to be mounted on 1 door – owner to determine which door.
Hook up and electric work done by owner
All glass to be laminated safety glass

TOTAL PRICE FOR ABOVE, INSTALLED: \$23,862.00

Alternate quote - to install impact resistant film on doors & sidelites

ADDITIONAL PRICE, INSTALLED: \$3,000.00

Thank you,

Ted Rice

Waverly Glass, Inc.

CUSTOMER SIGNATURE /
ACCEPTANCE OF QUOTE: _____

TITLE: _____ DATE: _____

* Idle time incurred by Waverly Glass, Inc. due to absence of non-Waverly Glass, Inc. supplied materials, required escorts, clearances, permits, inability to enter work place or other factors beyond our control will be billed at \$85.00 per man/hour.

Invitation to Bid

The Hickman County Finance Office is accepting bids for "Concrete Pouring At Schools" 2020-2021.

Specifications can be found at www.hickmank12.org/request-for-proposal or available by calling 931-729-3391 Ext. 3.

Sealed bids must be mailed or hand delivered to the Hickman County Finance Office, 114 North Central Avenue, Suite 203, Centerville, TN 37033 and clearly marked on the outside of the envelope "Concrete Pouring At Schools".

Bids will be opened on Monday, May 4, 2020 at 11:15 a.m. in the Finance Office.

The Hickman County Board of Education reserves the right to accept or reject any and all bids or parts of bids and to waive any informalities that would prevent the acceptance of a better bid.

Present
Cardi Dan
C. Fitzgerald

Lee Adcock Construction = \$ see attached

~~10~~

Part B BID FORM/ FILL in below and attach to bid documents

SPECS: Concrete Pouring at Schools

Scope: This bid is a one year bid price for Flat work forming, pouring, finishing and all materials and labor to be included in the per square foot bid. Bid may specify a sur-charge for delivery in addition to cost per square or linear foot in event it is less than full truck load of concrete.

All bidders must comply with TCA 49-5-406 regarding no prior felons, or prior sex offenders may work on school properties and all workers must be random drug tested yearly, and bidders must submit a letter affidavit that they are in compliance to this requirement. Meeting all Federal, State, and local laws.

Bidders must maintain and attach the following:

1 million dollar Liability insurance certificate, Workers compensation insurance certificate, and a TN business license or TN contractor license for concrete work.

Square foot rate is to include the following:

Excavation of dirt of not less than 8 inches, with 4 inches compacted ¾ stone rock or pug mix, and formed and finished to level surfaces to not cause trip or mower hazards. All surrounding disturbed areas, rock, debris to be clean up and seed and straw to a finished look. Concrete finishing to be smooth troweled or broom finish as specified for the specific job. Flat work is to have wire, expansion joints sawed in, and when need rebar. All Concrete to be 4500 psi unless otherwise specified.

Bid this work on this form and attach paper documents to bid.

FLAT WORK BY Square foot \$ 21.00

REBAR IF NEEDED \$ 6.00 per LF #4

SUR CHARGE FOR POURS LESS THAN TRUCK LOAD: \$ 1800.00

Ditch paving is to be excavated, formed, and to be level to grade as to not cause trip hazards and or mower damages. All disturbed areas are to be cleaned up free of rocks and finished grade, seeded and straw covered, upon completion of work. All concrete to be 4500 PSI unless otherwise specified.

Ditch paving by linear foot:

3 ft. width \$ 420.00

4 ft. width \$ 480.00

6 ft. width \$ 540.00

Curbing repair/ pouring: 18 inch width by 12 inch height

\$ 72.00 linear foot price

LEO ADCOCK CONSTRUCTION

Kent Holt

State of Tennessee

364048 1991249

BOARD FOR LICENSING CONTRACTORS

CONTRACTOR

LEE ADCOCK CONSTRUCTION CO. INC

This is to certify that all requirements of the State of Tennessee have been met.

ID NUMBER: 27767

LIC STATUS: ACTIVE

EXPIRATION DATE: January 31, 2022

UNLIMITED; BC; BC-B; CE; CE-B; CMC; HRA-A; HRA-C; MU-A; MU-

C



IN-1313
DEPARTMENT OF
COMMERCE AND INSURANCE

Invitation To Bid

The Hickman County Finance Office is accepting sealed bids for **"School Security Camera Systems"**.

Specifications can be found on-line at: www.hickmank12.org/request-for-proposal.

Sealed bids must be mailed or hand delivered to the Hickman County Finance Office, 114 North Central Avenue, Suite 203, Centerville, TN 37033 and clearly marked on the outside of the envelope **"School Security Camera Systems"**. Bids will be opened on May 4, 2020 at 10:45 a.m. in the Finance Office.

The Hickman County Board of Education reserves the right to accept or reject any and all bids or parts of bids and waive any informalities that would prevent the acceptance of a better bid.

Present

Candi Davis

~~C. Fitzgerald~~

BGC systems = see attached

Howard Technology = see attached

Edu Tech Inc. = see attached

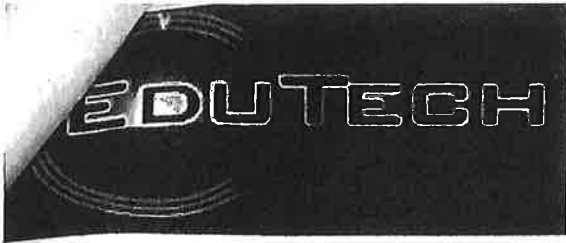

1150 Henry Street, Suite 4
 Dyersburg, TN 38024
 Phone: 800-324-1105
 Cell: 731-694-1092
 Fax: 731-285-0887
 don@edutech-tn.com

School Security Camera Systems - Hickman County Schools

Bid Form and Specifications/Scope of Work

The following Bid Form and Specifications/Scope of Work are to be used to submit bids by school.

Complete Pricing on this FORM and return with BID:

Camera Types: (cost should include any related licensing)
 (All cameras must be network capable)

Option 1: Trueview Camera System

Camera Type	Price	Licensing
Single HD Dome Camera:	Trueview TI-NC4053VDL \$200.00 5MP 2.8-12mm Mounts on Wall or Ceiling	No additional license needed.
Multi-position HD Camera: (minimum of 4 views)	Trueview DS-2CD6986F \$1,295.00 8MP Panoramic Camera with Wall Mount	No additional license needed.
HD PTZ Camera:	Trueview NP112-IR/25X \$695.00 25X with Wall Mount	No additional license needed.
HD Bullet:	Trueview TI-NC4053VDL \$200.00 5MP 2.8-12mm Mounts on Wall or Ceiling	No additional license needed.
POE Mini Switch	4 Port POE \$65.00	N/A
	8 Port POE \$125.00	N/A
	24 Port POE \$425.00	N/A
Cat. 6 Network Drop (Riser)	\$150.00	N/A

Installation and all related materials

School	Installation Cost (including all related materials)	Other related Cost (please provide specifics on a separate sheet)
East Hickman High School	\$95.00 Per Camera	N/A
Hickman County High School	\$95.00 Per Camera	N/A
Options For NVRS and VMS		
32 Channel NVR with 10TB HD	Trueview NRA-710-32 \$1,995.00	N/A
64 Channel NVR with 20TB HD	Trueview NRA710-64 \$2,995.00	N/A
VMS Software	Trueview VMS-4200	No additional cost Unlimited Lic.

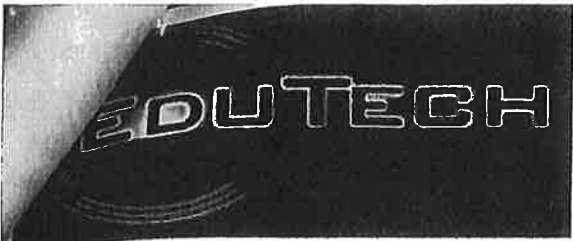

1150 Henry Street, Suite 4
 Dyersburg, TN 38024
 Phone: 800-324-1105
 Cell: 731-694-1092
 Fax: 731-285-0887
 don@edutech-tn.com

School Security Camera Systems - Hickman County Schools

Bid Form and Specifications/Scope of Work

The following Bid Form and Specifications/Scope of Work are to be used to submit bids by school.

Complete Pricing on this FORM and return with BID:

**Camera Types: (cost should include any related licensing)
 (All cameras must be network capable)**

Option 2: Axis Cameras

Camera Type	Price	Licensing
Single HD Dome Camera:	Axis M3065V \$286.00	Axis ACS Core Lic. \$80.00
Multi-position HD Camera: (minimum of 4 views)	Axis P3737-PLE4 \$1,345.00 Axis PTZ Wall Mount \$240.00	Axis ACS Core Lic. \$80.00
HD PTZ Camera:	Axis M5525-E PTZ \$750.00	Axis ACS Core Lic. \$80.00
HD Bullet:	Axis M2025LE \$326.00	Axis ACS Core Lic. \$80.00
POE Mini Switch	4 Port POE \$65.00	N/A
	8 Port POE \$125.00	N/A
	24 Port POE \$425.00	N/A
Cat. 6 Network Drop (Riser)	\$150.00	N/A

Installation and all related materials

School	Installation Cost (including all related materials)	Other related Cost (please provide specifics on a separate sheet)
East Hickman High School	\$95.00 Per Camera	N/A
Hickman County High School	\$95.00 Per Camera	N/A
Option 1 Bid is for installation Axis Cameras and Licenses on existing Axis Camera Stations. Does not include any additional VMS Software		

Howard

School Security Camera Systems - Hickman County Schools

Bid Form and Specifications/Scope of Work

The following Bid Form and Specifications/Scope of Work are to be used to submit bids by school.

Complete Pricing on this FORM and return with BID:

Camera Types: (cost should include any related licensing)

(All cameras must be network capable)

See attached Quotes

Camera Type	Price	Licensing
Single HD Dome Camera:	\$205.00	
Multi-position HD Camera: (minimum of 4 views)		
HD PTZ Camera:		
HD Bullet:		
POE Mini Switch		

Installation and all related materials

School	Installation Cost (including all related materials)	Other related Cost (please provide specifics on a separate sheet)
East Hickman High School	\$21,350.00	\$2,465.00 Programming
Hickman County High School	\$18,475.00	\$1,935.00

School Security Camera Systems - Hickman County Schools

Bid Form and Specifications/Scope of Work

The following Bid Form and Specifications/Scope of Work are to be used to submit bids by school.

Complete Pricing on this FORM and return with BID:

Camera Types: (cost should include any related licensing)
(All cameras must be network capable)

Camera Type	Price	Licensing
Single HD Dome Camera:	\$295.00	\$78.00
Multi-position HD Camera: (minimum of 4 views)	\$1,129.00	\$78.00
HD PTZ Camera:	\$859.00	\$78.00
HD Bullet:	\$549.00	\$78.00
POE Mini Switch	\$399	\$0

*Additional Option- Axis P3719-PL-15MP 4 Way Multi-position HD Camera: \$1,309.00-Camera, License Cost \$78.00

Installation and all related materials

School	Installation Cost (including all related materials)	Other related Cost (please provide specifics on a separate sheet)
East Hickman High School	\$185.00	Included
Hickman County High School	\$185.00	Included



Scope of Work

**ATTENTION:
Hickman County School District
Brad Gilbert**

**FROM:
Bluegrass Computer Systems, LLC
174 Saundersville Road, Suite 501
Hendersonville, TN 37075**

**SUBJECT:
School Security Camera Systems (HCHS &EHHS)**

Sealed BID

**May 4, 2020
10:45am
Technical Acknowledgements/ Notes /Scope of Work**

Scope of Work Response:

Section 1:

- 1.1-** All cameras quoted are Axis 1080p cameras to provide clear visualization of all areas school building hallways, office areas, and main entry points.

1.2 During a walkthrough of both HCHS and EHHS by BGCS Project Manager, Philip Draude and Mr. Brad Gilbert, the following camera counts were determined to provide adequate indoor coverage. Outdoor coverage, driveway entry and exit points are provided in camera counts below, in a minimal to moderate basis as, achieving indoor coverage was the stronger preference at the time. Outdoor coverage is best achieved by utilizing bullet or PTZ (Pan/Tilt/Zoom) Cameras, both provide quality coverage and visualization, however the PTZ also provides the option to “zoom-in” on live or recorded camera footage. The ability to live capture and render license plate information in an automated function can be achieved but requires attritional equipment from Axis than provided on the Bid.

EHHS:

Proposed Camera Counts

Dome - 34
Bullet - 13
4 way - 8
PTZ - 1

HCHS:

Proposed Camera Counts

Dome - 18
Bullet - 13
4 way - 12
PTZ - 1

In order to provide the most flexibility for the district, BGCS is able to provide all pricing for cameras as a unit price per camera, with no minimum or maximum. The camera count above is set to meet the requirements of the bid, however BGCS is not placing cameras on school maps in order to allow the best placement and quantity to be used in the areas most in need to be monitored by the school. During installation, BGCS can provide live video to school personal to ensure proper areas are being covered in full and adjust alignment and placement of the camera to achieve the best performance for the school district. This service is provided at no charge to the school district.

1.3

- 1) The Video Management Solution (VMS) quoted is the Axis Camera Station Manager. HCSS will find best utilization with the Axis Camera Station Manager as this VMS is already utilized throughout the district with the exception of the two high schools. Providing the following benefits
 - a. HCSS Staff is already trained in how to use the Axis Camera Station Manager Desktop Application and Mobile App. Additionally, school administrations are familiar with exporting recordings, adjusting PTZ Camera angles and correctly responding to real life emergency situations from a centralized point.
 - b. Storage for newly added cameras will be provided by an existing Synology NAS located at the Hickman Co. Central Office. Cloud based storage will not need to be utilized.
 - c. HCSS is currently providing storage via the Synology device to 111 cameras throughout the district, with a 30-day retention policy. This utilization has consumed 914GB of storage, leaving the Synology device with 18.85TB of storage remaining. Using a like camera mixture and continuing to observe correct overhead reserve requirements, HCSS could deploy upwards of 500 additional cameras before possibly considering any other storage needs. Additional server resources may be required in order to provide overhead to the Axis Camera Station Manager Server. If such server resources are required, the current virtual cluster at the Hickman County Central Office can be utilized with no new hardware purchase. BGCS will complete required labor in order to facilitate this.
 - d. HCSS will provide PoE network switching to power all cameras within the school. PoE switches may need to be placed in areas where a network rack is not located in order to assist with cable drop locations. HCSS will have final decision in location, BGCSystems will make suggestions to aid in this decision.

1.4

The VMS utilized is Axis Camera Station, which is manufactured, supported and maintained to be fully compatible with Axis Cameras. BGCSystems is a licensed Axis Partner to sell and support all Axis products. There is no expiration date to BGCSystems' partnership with Axis. BGCS Axis Partner ID:379351. BGCS is set to receive Gold level partnership with Axis in Q2 of 2020.

Section 3: Service and Support

- a. VMS - BGCSystems will continue to provide service to HCSS's Axis infrastructure under the current BGCS Max agreement. Response time should be provided under 24 hours. Monitoring 24/7 is provided to LEASVRB which notifies BGCS within 5 minutes of any power or network outage. BGCS provides a toll-free number for HCSS to utilize for support.
- b. Upgrades and options would come only in the form of Axis Camera Station Manager updates. At of the time of this document, upgrading to the newest software is provided at no cost to HCSS. Axis may choose to change this in the future but no announcement has been made at this point.
- c. All licensing is included in pricing on the attached pricing matrix of this bid.
- d. There are no additional yearly fees or costs to maintain any Axis hardware or software.
- e. BGCS will provide service and maintenance to the Axis Camera Servers through secure remote connection at no additional costs to HCSS. Maintenance is provided on a monthly or as needed basis to perform a simple "Database Maintenance" This is a tool inside the Axis Camera Station Manager to keep the Database healthy on the Synology device. The time to complete this maintenance is depend on how many cameras on being utilized on the server but usually can be completed overnight or on a weekend if the school district prefers.

4) Installation

- a. Pre-Planning – BGCS will consult with School Personnel to understand budget requirements, camera placement and timelines since the pre-planning period will follow bid and pricing acceptance.
- b. Sourcing/Product Acquisition - BGCSystems will acquire all products from a licensed Axis distributor.
- c. Delivery – Upon receipt of a PO from HCSS, BGCSystems will deliver and install cameras and all required materials to the scheduled school/destination. HCSS will not be required to hold any inventory or parts. All items will be installed at the school or housed securely at the BGCSystems Headquarters.
- d. Installation - BGCSystems will provide installation of all camera products, mounts, accessories and software. All camera products will be installed by BGCSystems' employees to a high degree of construction quality, protecting HCSS assets. HCSS is being asked to provide outdoor easement for all outdoor cameras. More specifically, HCSS shall provide a drilled hole through outdoor masonry, allowing BGCSystems to freely pull CAT6 cable from above the indoor drop ceiling through the masonry wall to the outdoor location. In addition, HCSS will be asked to attach camera mounts directly to school buildings when the mount must be attached directly to the building's exterior or when the proposed camera mounting location requires the use of a "bucket truck/cherry picker" Essentially, BGCSystems will require the assistance of HCSS to drill through or mount to any masonry material, indoor or outdoor. In the event an indoor camera mount location exceeds the height of 8 feet, BGCSystems will require the use of an interior "scissor lift". BGCSystems will provide all interior camera mounting as well as all indoor and outdoor CAT6 cable drops.

- e. Schedule - BGCSystems respects the schedule of HCSS and agrees to install at convenient times for HCSS. BGCSystems has worked with HCSS for several years and has become extremely familiar with school staff, administration, requirements, and expectations for being inside a school and around students during school hours. In addition to working closely with HCSS, BGCSystems also works with various other K-12 school districts and is knowledgeable of requirements and expectations for working inside a school district. BGCSystems assumes cleanup responsibility at the end of any job and maintains all tools and equipment nearby during work hours.
- f. Inventory lists will be provided per school instruction and will include asset tagging if requested.

Contractor Qualifications

- g. Tennessee State Contractors license with \$500,000 per location limit for Specialty electrical (Category data cable) Please see attached copy of Contractors license.
- h. VMS certification-BGCSystems' Axis Authorized Partner Number is 379351.
- i. Matthew Barnes, President of BGCSystems will serve as the Single Point of Contact.
- j. Both Matthew Barnes and Philip Draude have worked with HCSS for several years personally and are extremely familiar with the district and their overall expectations. Mr. Draude has spent several years running data cable and providing various multi-media services to K-12 schools, including HCSS. The installation of existing Axis infrastructure was installed and designed by BGCSystems. Mr. Barnes has likewise spent years working with K-12 schools districts for various IT needs, including HCSS, and as the owner of BGCSystems, has full control of the quality and efficiency of the project.

k. Subcontractors- BGCSystems will not utilize any subcontractors in any way for this project.

State of Tennessee

11041435
344353

BOARD FOR LICENSING CONTRACTORS

CONTRACTOR

BLUEGRASS COMPUTER SYSTEMS, LLC

This is to certify that all requirements of the State of Tennessee have been met.

ID NUMBER: 699993
LIC STATUS: ACTIVE
EXPIRATION DATE: June 30, 2020
AGLM \$500,000.00; S-Low Voltage



IN-1313
DEPARTMENT OF
COMMERCE AND INSURANCE



3 YEAR LIMITED HARDWARE WARRANTY

Warranty Coverage

Axis warrants the original purchaser (the distributor) that the **Axis hardware** will be free from defects in design, workmanship and materials under substantiated normal use for a period of three (3) years from the date of the original purchase ("Warranty Period"). This Warranty is only applicable to the Axis hardware and accessories included with the Axis Hardware on the date of the original purchase (hereinafter jointly referred to as "Axis Hardware").

The original purchaser shall without undue delay notify Axis of any defect that appears in the Axis Hardware in accordance with Axis' RMA handling. Failure to notify Axis of said defect shall mean that the original purchaser loses the right to have the defect remedied. A valid form of bill of sale or receipt, substantiating the purchase and the date thereof, must be presented to Axis within the Warranty Period to obtain warranty service. The sole remedy of the original purchaser and Axis' sole and exclusive liability shall be limited to, at Axis' sole discretion, either repair of the Axis Hardware using new or refurbished replacement parts, or replacement of the Axis Hardware. Repaired Axis Hardware or replacement hardware products will be warranted under the terms set forth herein for the remainder of the original Warranty Period or ninety (90) days, whichever is longer. When the Axis Hardware or part thereof is replaced, all products or parts thereof that are replaced shall become the property of Axis. This Warranty is applicable in all countries and may be enforced by contacting Axis Support. For more information, please visit www.axis.com/support.

Exclusions and Limitations

This Warranty is contingent upon proper warehousing, shipment and substantiated normal use of the Axis Hardware, and specifically does not apply if the Axis Hardware has had the model or serial number altered, defaced or removed, or to defects attributable to (i) modifications to or alterations of the Axis Hardware by any party other than Axis, (ii) faulty maintenance, incorrect installation or faulty repair by any party other than Axis, (iii) use of the Axis Hardware for a purpose for which it was not designed or intended, (iv) normal wear and tear or deterioration, or (v) misuse, abuse, negligence or accidents.

This Warranty does not apply to Axis Hardware that was purchased "as is" or where Axis, the seller or the liquidator expressly has disclaimed their warranty obligation pertaining to the product. Also, the Warranty only applies to Axis Hardware purchased from an authorized distributor/reseller. Furthermore, this Warranty only applies if and to the extent that it is not in conflict with applicable export control regulations, sanctions or embargos.

THE WARRANTY PROVIDED ABOVE IS THE ONLY WARRANTY APPLICABLE BETWEEN THE ORIGINAL PURCHASER AND AXIS WITH RESPECT TO THE AXIS HARDWARE AND NO OTHER WARRANTIES OF ANY KIND SHALL APPLY. TO THE MAXIMUM EXTENT PERMITTED BY APPLICABLE LAW, AXIS DISCLAIMS AND EXCLUDES ALL OTHER WARRANTIES OTHER THAN THE EXPRESS WARRANTIES SET FORTH ABOVE, WHETHER STATUTORY, EXPRESS OR IMPLIED, INCLUDING ANY IMPLIED WARRANTIES OF MERCHANTABILITY, FITNESS FOR A PARTICULAR PURPOSE, TITLE AND NON-INFRINGEMENT. CERTAIN JURISDICTIONS DO NOT ALLOW THE EXCLUSION OF WARRANTIES AS SET FORTH HEREIN. IF LAWS UNDER SUCH JURISDICTIONS APPLY, THEN ALL EXPRESS AND IMPLIED WARRANTIES ARE LIMITED TO THE WARRANTY PERIOD IDENTIFIED ABOVE, AND OTHERWISE TO THE MAXIMUM EXTENT PERMITTED BY LAW. EXCEPT AS PROVIDED IN THIS WRITTEN WARRANTY OR TO THE MINIMUM EXTENT REQUIRED BY MANDATORY LAW, NEITHER AXIS NOR ANY OF ITS AFFILIATES SHALL BE LIABLE FOR ANY SPECIAL, INCIDENTAL, CONSEQUENTIAL, PUNITIVE OR INDIRECT LOSSES OR DAMAGES INCLUDING LOSS OF DATA, LOSS OF PROFIT, REVENUE OR PRODUCTION, INTEREST ON INVESTMENTS, LOSS OF GOODWILL, COST OF CAPITAL, COST OF SUBSTITUTE EQUIPMENT, FACILITIES OR SERVICES, DOWNTIME COSTS OR CLAIMS OF CUSTOMERS REGARDLESS OF WHETHER SUCH PARTY HAS BEEN ADVISED OF THE POSSIBILITY OF THE SAME. AXIS' TOTAL AND AGGREGATE LIABILITY FOR ALL CLAIMS UNDER THIS WARRANTY SHALL BE LIMITED TO AND IN NO CASE EXCEED THE PRICE PAID FOR THE AXIS HARDWARE. THESE LIMITATIONS ON POTENTIAL LIABILITIES HAVE BEEN AN ESSENTIAL CONDITION IN SETTING THE PRODUCT PRICE.

Applicable Law

- This Warranty is governed by and construed under the laws of Sweden.
- This Warranty may be subject to Axis' change at any time without prior notice.

School Security Camera Systems - Hickman County Schools

Bid Form and Specifications/Scope of Work

The following Bid Form and Specifications/Scope of Work are to be used to submit bids by school.

Complete Pricing on this FORM and return with BID:

Camera Types: (cost should include any related licensing)
(All cameras must be network capable)

Camera Type	Price	Licensing
Single HD Dome Camera:	\$295.00	\$78.00
Multi-position HD Camera: (minimum of 4 views)	\$1,129.00	\$78.00
HD PTZ Camera:	\$859.00	\$78.00
HD Bullet:	\$549.00	\$78.00
POE Mini Switch	\$399	\$0

*Additional Option- Axis P3719-PL-15MP 4 Way Multi-position HD Camera: \$1,309.00-Camera, License Cost \$78.00

Installation and all related materials

School	Installation Cost (including all related materials)	Other related Cost (please provide specifics on a separate sheet)
East Hickman High School	\$185.00	Included
Hickman County High School	\$185.00	Included

Dome Data Sheet



Replacement to last year's
M3105-L

AXIS M3115-LVE Network Camera

Affordable flat-faced 1080p dome with IR

AXIS M3115-LVE is an affordable, flat-faced dome designed to suppress light reflections. This compact, IK08-rated camera features a wide-angle view in HDTV 1080p video. It includes Forensic WDR, Lightfinder and built-in IR illumination for sharp video with clear colors even in challenging light or complete darkness. Additionally, it offers flexible installation for both indoor and outdoor surveillance. And, with its 3-axis camera-angle adjustment, it can be easily leveled and directed. It features enhanced security functionality, and Axis Zipstream with support for H.264/H.265 significantly reduces bandwidth and storage requirements without compromising image quality.

- > HDTV 1080p video quality
- > Forensic WDR, Lightfinder and IR illumination
- > Flat-faced design suppressing light reflections
- > Zipstream supporting H.264 and H.265
- > Signed firmware and secure boot

Upgrades:

- IP66 Outdoor Rated vs IP42
- 512MB Flash
- LightFinder Technology
- IR illumination Extended to 65ft from 50ft



AXIS M3115-LVE Network Camera

Camera		Pre- and post-alarm video or image buffering for recording or upload Notification: email, HTTP, HTTPS, TCP, and SNMP trap Overlay text
Image sensor	1/2.9" progressive scan RGB CMOS	
Lens	2.8 mm, F2.0 Horizontal field of view: 105° Vertical field of view: 58° Fixed iris, Fixed focus, IR corrected	
Day and night	Automatically removable infrared-cut filter	
Minimum illumination	Color: 0.17 lux at 50 IRE, F2.0 B/W: 0.03 lux at 50 IRE, F2.0 0 lux with IR illumination on	
Shutter time	1/33500 s to 2 s	
Camera angle adjustment	Pan: ±180° Tilt: 0° to 60° (0° = lens directed at a right angle to camera base) Rotation: ±95° Can be directed in any direction and see the wall/ceiling	
Video		
Video compression	H.264 (MPEG-4 Part 10/AVC) Baseline, Main and High Profiles H.265 (MPEG-H Part 2/HEVC) Main Profile Motion JPEG	
Resolution	1920x1080 to 160x90	
Frame rate	Up to 25/30 fps with power line frequency 50/60 Hz	
Video streaming	Multiple, individually configurable streams in H.264, H.265 and Motion JPEG Axis Zipstream technology in H.264 and H.265 Controllable frame rate and bandwidth VBR/ABR/MBR H.264/H.265	
Multi-view streaming	Up to 2 individually cropped out view areas in full frame rate	
Image settings	Compression, color saturation, brightness, sharpness, contrast, local contrast, white balance, day/night threshold, tone mapping, exposure control (including automatic gain control), exposure zones, Forensic WDR: up to 120 dB depending on scene, fine tuning of low-light behavior, defogging, dynamic text and image overlay, privacy masks, mirroring, rotation: 0°, 90°, 180°, 270° including Corridor Format	
Pan/Tilt/Zoom	Digital PTZ	
Audio		
Audio input/output	Two-way audio connectivity via the optional AXIS T61 Audio and I/O Interfaces with portcast technology	
Network		
Security	Password protection, IP address filtering, HTTPS ^a encryption, IEEE 802.1x (EAP-TLS) ^a network access control, Digest authentication, User access log, Centralized Certificate Management, brute force delay protection, signed firmware, secure boot	
Supported protocols	IPv4, IPv6 USGv6, HTTP, HTTPS ^a , SSI/TLS ^a , QoS Layer 3 DiffServ, FTP, SFTP, CIFS/SMB, SMTP, Bonjour, UPnP [®] , SNMP v1/v2c/v3 (MIB-II), DNS, DynDNS, NTP, RTSP, RTP, SRTP, TCP, UDP, IGMP, RTCP, ICMP, DHCP, ARP, SOCKS, SSH, SIP, LLDP	
System integration		
Application Programming Interface	Open API for software integration, including VAPIX [®] and AXIS Camera Application Platform; specifications at axis.com AXIS Video Hosting System (AVHS) with One-Click Connection ONVIF [®] Profile G, ONVIF [®] Profile S, and ONVIF [®] Profile T, specification at onvif.org Support for Session Initiation Protocol (SIP) for integration with Voice over IP (VoIP) systems, peer to peer or integrated with SIP/PBX.	
Analytics	Included AXIS Video Motion Detection, tampering alarm Supported AXIS Fence Guard, AXIS Motion Guard, AXIS Loitering Guard Support for AXIS Camera Application Platform enabling installation of third-party applications, see axis.com/acap	
Event triggers	Analytics, Edge storage events, Virtual inputs through API	
Event actions	Record video: SD card and network share Upload of images or video clips: FTP, SFTP, HTTP, HTTPS, network share, and email	
Data streaming	Event data	
Built-in installation aids	Pixel counter, adjustable IR-illumination intensity	
General		
Casing	IP66- and NEMA 4X-rated, IK08 impact-resistant casing Encapsulated electronics and captive screws (Torx 10) Color: white NCS S 1002-B For repainting instructions and impact on warranty, contact your Axis partner	
Sustainability	PVC free	
Memory	512 MB RAM, 512 MB Flash	
Power	Power over Ethernet (PoE) IEEE 802.3af/802.3at Type 1 Class 3 Typical: 3.7 W, Max.: 7 W	
Connectors	RJ45 10BASE-T/100BASE-TX PoE Audio and I/O connectivity via the optional AXIS T61 Audio and I/O Interfaces with portcast technology	
IR illumination	Power-efficient, long-life 850 nm IR LED. Range of reach 20 m (65 ft) or more depending on the scene	
Storage	Support for microSD/microSDHC/microSDXC card and encryption Recording to network-attached storage (NAS) For SD card and NAS recommendations see axis.com	
Operating conditions	-30 °C to 50 °C (-22 °F to 122 °F) Start-up temperature: -20 °C to 50 °C (-4 °F to 122 °F) Humidity 10–100% RH (condensing)	
Storage conditions	-40°C to 65°C (-40°F to 149 °F) Humidity 5–95% RH (non-condensing)	
Approvals	EMC EN 55024, EN 55032 Class A, EN 55035, EN 61000-6-1, EN 61000-6-2, FCC Part 15 Subpart B Class A, KC KN32 Class A, KC KN35, RCM AS/NZS CISPR 32 Class A, ICES-3(A)/NMB-3(A), VCCI Class A Environment IEC 60068-2-1, IEC 60068-2-2, IEC 60068-2-78, IEC 60068-2-14, IEC 60068-2-6, IEC 60068-2-27 IEC/EN 62262 IK08, IEC/EN 60529 IP66, NEMA 250 Type 4X Safety IEC/EN/UL 60950-22, IEC/EN/UL 62368-1, IEC/EN 62471 Network NIST SP500-267, IPv6 USGv6	
Dimensions	Height: 94 mm (3.7 in) ø 101 mm (4.0 in)	
Weight	390 g (0.85 lb)	
Included accessories	Installation Guide, Windows decoder 1-user license, Torx [®] L-key, Connector guard, Cable gasket	
Optional accessories	AXIS T94B02D Pendant kit, AXIS T94B01P Conduit Back Box, AXIS T94B02M J-Box/Gang Box Plate, AXIS TM3807 Black Casing, Axis Mounts, AXIS Surveillance microSDXC [™] Card, AXIS Weathershield Kit C, AXIS T61 Audio and I/O Interface Series For more accessories, see axis.com	
Video management software	AXIS Companion, AXIS Camera Station, Video management software from Axis' Application Development Partners available on axis.com/vms	
Languages	English, German, French, Spanish, Italian, Russian, Simplified Chinese, Japanese, Korean, Portuguese, Traditional Chinese	
Warranty	Axis 3-year warranty and AXIS Extended Warranty option, see axis.com/warranty	

a. This product includes software developed by the OpenSSL Project for use in the OpenSSL Toolkit. (www.openssl.org), and cryptographic software written by Eric Young (ey@cryptsoft.com).

Environmental responsibility:
axis.com/environmental-responsibility

4 Way 8MP Multi-Position Data Sheet

Replacement to last year's

AXIS P3717-PLE Network Camera P3707

8 MP multidirectional camera with IR for 360° coverage

AXIS P3717-PLE Network Camera is a compact 8-megapixel camera with four varifocal lenses enabling overview and detailed surveillance. With one IP address and one network cable, the four-camera-in-one unit provides a flexible, cost-effective solution for multidirectional surveillance. 360° IR illumination, Forensic WDR and Lightfinder technology provides excellent video quality in any light conditions. Each camera head can be individually positioned (pan, tilt, roll and twist) along a circular track. Remote zoom and focus makes it easy to install and the clear cover, with no sharp edges, ensures undistorted views in all directions. The camera comes with an integrated weathershield.

- > 8 MP, 360° multidirectional camera, one IP address
- > 360° IR illumination and remote zoom and focus
- > Axis Lightfinder and Forensic WDR
- > Flexible positioning of four varifocal camera heads
- > Axis Zipstream for reduced bandwidth and storage needs

Upgrades:

-1080P on each lens @25/30fps vs 1080p Quad Screen

-LightFinder Technology

-Outdoor, IK09 Vandal Rated



AXIS P3717-PLE Network Camera

Camera		Data streaming	Event data
Image sensor	4 x 1/2.8" progressive scan RGB CMOS	Built-in installation aids	Pixel counter, focus assistant, remote focus, remote zoom
Lens	Varifocal, 3–6 mm, F1.8–2.6 4x1080p capture mode: Horizontal field of view: 96°–49° Vertical field of view: 53°–27° Diagonal field of view: 113°–55° Motorized focus, motorized zoom	General	
Day and night	Automatically removable infrared-cut filter	Casing	IP66-, IP67-, NEMA 4X-rated, IK09 impact-resistant, aluminium and plastic casing with polycarbonate hard-coated dome, sunshield (PC/ASA) Color: white NCS S 1002-B For repainting instructions of casing and impact on warranty, contact your Axis partner.
Minimum illumination	Color: 0.17 lux at 50 IRE F1.8 B/W: 0.04 lux at 50 IRE F1.8, 0 lux with IR illumination on	Mounting	Mounting bracket with junction box holes (double gang box, single gang box, 4" octagon junction box and 4" square junction box) 1/2" (M20) conduit side entry 3/4" (M25) conduit adapter included
Shutter time	1/32500 s to 2 s with 50 Hz 1/32500 s to 2 s with 60 Hz	Sustainability	PVC free
Camera angle adjustment	Pan ±90°, tilt +25 to +95°, rotation –5 to +95°, twist ±20°	Memory	1024 MB RAM, 512 MB Flash
Video		Power	Power over Ethernet (PoE) IEEE 802.3at Type 2 Class 4 IR illumination on: class 4, typical 11.1 W, max 17.0 W IR illumination off: class 3, typical 8.6 W, max 11.0 W
Video compression	H.264 (MPEG-4 Part 10/AVC) Baseline, Main and High Profiles Motion JPEG	Connectors	
Resolution	4 x 1920x1080 (4 x HDTV 1080p) to 160x90	Shielded RJ45 10BASE-T/100BASE-TX PoE Audio and I/O connectivity via AXIS T61 Audio and I/O Interfaces with portcast technology	
Frame rate	Up to 25/30 fps (50/60 Hz)	IR illumination	
Video streaming	Multiple, individually configurable streams in H.264 and Motion JPEG Axis Zipstream technology in H.264 Controllable frame rate and bandwidth VBR/ABR/MBR H.264	Four individually controllable IR with power-efficient, long-life 850 nm IR LEDs Range of reach 15 m (50 ft) or more depending on the scene	
Image settings	Saturation, contrast, brightness, sharpness, Forensic WDR, white balance, exposure control, exposure zone, fine tuning of behavior at low light, rotation: 0°, 90°, 180°, 270° including Corridor Format, dynamic text and image overlay, Polygon privacy mask, compression	Storage	Support for microSD/microSDHC/microSDXC card Dual SD cards Support for SD card encryption Support for recording to network-attached storage (NAS) For SD card and NAS recommendations see axis.com
Audio		Operating conditions	–30 °C to 50 °C (–22 °F to 112 °F) Humidity 10–100% RH (condensing)
Audio input/output	Two-way audio connectivity via AXIS T61 Audio and I/O Interfaces with portcast technology A 30 W midspan or higher between AXIS T61 Audio and I/O Interfaces and AXIS P3717-PLE is required.	Storage conditions	–40 °C to 65 °C (–40 °F to 149 °F)
Network		Approvals	
IP address	One IP address for all channels	EMC EN 55032 Class A, EN 50121-4, IEC 62236-4, EN 61000-3-2, EN 61000-3-3, EN 55024, EN 61000-6-1, EN 61000-6-2, FCC Part 15 Subpart B Class A, ICES-003 Class A, VCCI Class A, RCM AS/NZS CISPR 32 Class A, KC KN32 Class A, KC KN35 Safety IEC/EN/UL 62368-1, IEC/EN/UL 60950-22, IEC 62471, IS 13252 Environment IEC 60068-2-1, IEC 60068-2-2, IEC 60068-2-6, IEC 60068-2-14, IEC 60068-2-27, IEC 60068-2-78, IEC/EN 60529 IP66/67, IEC/EN 62262 IK09, NEMA 250 Type 4X, NEMA TS 2-2016	
Security	Password protection, IP address filtering, HTTPS ^a encryption, IEEE 802.1X (EAP-TLS) ^a network access control, digest authentication, user access log, centralized certificate management, brute force delay protection, signed firmware, secure boot	Dimensions	
Supported protocols	IPv4/v6, HTTP, HTTPS ^a , SSL/TLS ^a , QoS Layer 3 DiffServ, FTP, CIFS/SMB, SMTP, Bonjour, UPnP™, SNMP v1/v2c/v3 (MIB-II), DNS, DynDNS, NTP, RTSP, RTP, SFTP, TCP, UDP, IGMP, RTCP, ICMP, DHCP, ARP, SOCKS, SSH, LLDP	Height: 91.5 mm (3.6 in) ø 255 mm (10.04 in)	
System integration		Weight	2.0 kg (4.4 lb)
Application Programming Interface	Open API for software integration, including VAPIX [®] and AXIS Camera Application Platform; specifications at axis.com AXIS Video Hosting System (AVHS) with One-Click Connection ONVIF [®] Profile G and ONVIF [®] Profile S, specification at onvif.org	Included accessories	
Analytics	Included AXIS Video Motion Detection, active tampering alarm Supported AXIS Guard Suite including AXIS Motion Guard, AXIS Fence Guard, and AXIS Loitering Guard Support for AXIS Camera Application Platform enabling installation of third-party applications, see axis.com/acap	RJ45 mounting tool, screw bit T20, Installation guide, Windows [®] decoder 1-user license	
Event triggers	Detectors, hardware, input signal, storage, system, time, analytics, edge storage events	Optional accessories	
Event actions	Day/night vision mode, overlay text, record video, send images, send notification, send SNMP trap, send video clip, status LED File upload: FTP, HTTP, HTTPS, network share, SFTP and email Notification: email, HTTP, HTTPS, TCP and SNMP trap	AXIS T94N01D Pendant Kit, Axis mounts and cabinets For more accessories, see axis.com	
		Video management software	AXIS Companion, AXIS Camera Station, video management software from Axis' Application Development Partners available at axis.com/vms
		Languages	English, Simplified Chinese, Traditional Chinese, French, German, Italian, Japanese, Korean, Polish, Portuguese, Russian, Spanish
		Warranty	Axis 3-year warranty, see axis.com/warranty

a. This product includes software developed by the OpenSSL Project for use in the OpenSSL Toolkit. (openssl.org), and cryptographic software written by Eric Young (ey@cryptsoft.com).

Environmental responsibility:

axis.com/environmental-responsibility

PTZ Data Sheet

AXIS M5525-E PTZ Network Camera -No model change from Indoor and outdoor PTZ with 10x zoom 2019

AXIS M5525-E PTZ Network Camera is a compact pan-tilt-zoom camera with HDTV 1080p resolution, 10x optical zoom, and autofocus, enabling great video quality in both overview and detail. Day/night functionality and WDR – Forensic Capture ensures maintained image quality in low or mixed light, and scene profiles are included for automatic optimization. AXIS M5525-E is compatible with any Axis PTZ mount for outdoor installation, but can also be surface-mounted indoors. Protected against dust, rain, snow, and corrosion, the camera operates in temperatures from -20 °C to 50 °C (-4 °F to 122 °F). The microSD card slot enables local video storage.

- > **HDTV 1080p with 10x optical zoom**
- > **Continuous 360° for uninterrupted pan**
- > **WDR — Forensic Capture**
- > **Axis Zipstream technology**
- > **I/O ports and two-way audio**



AXIS M5525-E PTZ Network Camera

Camera	
Image sensor	1/2.8" progressive scan CMOS
Lens	4.7–47 mm, F1.6–3.0 Horizontal field of view: 61.8°–6.7° Vertical field of view: 37.2°–3.8° Autofocus, auto-iris
Day and night	Automatically removable infrared-cut filter
Minimum illumination	Color: 0.45 lux at 30 IRE F1.6 B/W: 0.01 lux at 30 IRE F1.6 Color: 0.55 lux at 50 IRE F1.6 B/W: 0.01 lux at 50 IRE F1.6
Shutter time	1/66500 s to 2 s
Pan/Tilt/Zoom	Pan: 360° endless, 1.8°–150°/s Tilt: 90°, 1.8°–150°/s 10x optical zoom, 12x digital zoom, total 120x zoom Nadir flip, 100 preset positions, limited guard tour, control queue, on-screen directional indicator
Video	
Video compression	H.264 (MPEG-4 Part 10/AVC) Baseline, Main and High Profiles Motion JPEG
Resolution	1920x1080 to 320x180
Frame rate	Up to 25/30 fps with power line frequency 50/60 Hz
Video streaming	Multiple, individually configurable streams in H.264 and Motion JPEG Axis Zipstream technology in H.264 Controllable frame rate and bandwidth VBR/MBR H.264
Image settings	Saturation, brightness, sharpness, WDR – forensic capture, white balance, exposure mode, exposure zones, compression, text and image overlay, 20 individual 3D privacy masks, contrast, scene profiles, image freeze on PTZ, local contrast, max shutter, max gain, noise/motion priority, aperture lock, exposure level, rotation: 0°, 180°
Audio	
Audio streaming	Two-way, full duplex
Audio compression	AAC-LC 8/16/32 kHz, G.711 PCM 8 kHz, G.726 ADPCM 8 kHz Configurable bit rate
Audio input/output	External microphone input or line input, line output
Network	
Security	Password protection, IP address filtering, HTTPS ^a encryption, IEEE 802.1X ^a network access control, Digest authentication, User access log, Centralized Certificate Management, Brute force delay protection
Supported protocols	IPv4, IPv6 USGv6, HTTP, HTTPS ^a , SSL/TLS ^a , QoS Layer 3 DiffServ, FTP, SFTP, CIFS/SMB, SMTP, Bonjour, UPnP TM , SNMP v1/v2c/v3(MIB-II), DNS, DynDNS, NTP, RTSP, RTP, TCP, UDP, IGMP, RTPC, ICMP, DHCP, ARP, SOCKS, SSH, LLDP
System integration	
Application Programming Interface	Open API for software integration, including VAPIX [®] and AXIS Camera Application Platform; specifications at axis.com ONVIF [®] Profile S and ONVIF [®] Profile G, specification at onvif.org
Analytics	Included AXIS Video Motion Detection, audio detection, advanced gatekeeper Supported AXIS Cross Line Detection, AXIS Guard Suite including AXIS Fence Guard, AXIS Motion Guard and AXIS Loitering Guard Support for AXIS Camera Application Platform enabling installation of third-party applications, see axis.com/ocap
Event triggers	Analytics, edge storage events Detectors: day/night mode, live stream accessed, audio detection Hardware: network, temperature Input Signal: digital input port, manual trigger, virtual inputs PTZ: error, moving, preset reached, ready Storage: disruption, recording System: system ready
Event actions	Time: recurrence, use schedule Record video: SD card and network share Upload of images or video clips: FTP, SFTP, HTTP, HTTPS, network share, and email Pre- and post-alarm video or image buffering for recording or upload Notification: email, HTTP, HTTPS, TCP, and SNMP trap PTZ: PTZ preset, start/stop guard tour Overlay text, play audio clip, external output activation, WDR mode
Data streaming	Event data
Built-in installation aids	Pixel counter
General	
Casing	IP66-, NEMA 4X- and IK09-rated Repaintable plastic casing, polycarbonate (PC) dome
Sustainability	PVC free
Memory	512 MB RAM, 256 MB Flash
Power	Power over Ethernet (PoE) IEEE 802.3af/802.3at Type 1 Class 3 Typical 6.6 W, max 12.95 W 20–28 V DC, typical 6.3 W, max 13 W (PoE midspan and power supply not included)
Connectors	RJ45 10BASE-T/100BASE-TX PoE DC input terminal block I/O: 6-pin terminal block with push-in spring connection for four configurable inputs/outputs Audio: mic/line in, line out terminal block with push-in spring connection
Storage	Support for microSD/SDHC/SDXC card (not included) Support for SD card encryption Support for recording to network-attached storage (NAS) For SD card and NAS recommendations see axis.com
Operating conditions	-20 °C to 50 °C (-4 °F to 122 °F) Humidity 15–100% RH (condensing)
Storage conditions	-40 °C to 65 °C (-40 °F to 149 °F)
Approvals	EMC EN 55032 Class A, EN 61000-3-2, EN 61000-3-3, EN 55024, EN 61000-6-1, EN 61000-6-2, FCC Part 15 Subpart B Class A, ICES-003 Class A, VCCI Class A, RCM AS/NZS CISPR 32 Class A, KC KN32 Class A, KN35 Safety IEC/EN/UL 62368-1, IEC/EN/UL 60950-22, IS 13252 Environment IEC 60068-2-27, IEC 60068-2-6, IEC/EN 60529 IP66, IEC/EN 62262 IK09 Network NIST SP500-267
Dimensions	Height: 132 mm (5.2 in), ø 165 mm (6.5 in)
Weight	1.1 kg (2.4 lb) Recessed mount (plenum rated): 1.0 kg (2.2 lb)
Included accessories	Conduit adapter 3/4", smoked dome, adapter bayonette Installation Guide, Windows [®] decoder 1-user license
Optional accessories	AXIS T91 Mounting Accessories, AXIS T94P01L Recessed Mount Kit
Video management software	AXIS Companion, AXIS Camera Station, video management software from Axis' Application Development Partners available at axis.com/vms
Languages	English, German, French, Spanish, Italian, Russian, Simplified Chinese, Japanese, Korean, Portuguese, Traditional Chinese
Warranty	Axis 3-year warranty and AXIS Extended Warranty option, see axis.com/warranty

a. This product includes software developed by the OpenSSL Project for use in the OpenSSL Toolkit. (www.openssl.org), and cryptographic software written by Eric Young (ey@cryptsoft.com).

Environmental responsibility:
axis.com/environmental-responsibility

Bullet Data Sheet

Replacement from last year's
P1435-E

AXIS P1435-LE Network Camera

Compact and fully-featured HDTV for any light condition

With Lightfinder and WDR – Forensic Capture, the AXIS P1435-LE bullet camera provides excellent image quality in HDTV 1080p resolution. At low light, Axis' OptimizedIR automatically adapts the exposure of the camera resulting in high-quality and low-noise video. The camera features corridor format, pixel counter, remote zoom and focus, as well as P-Iris control – ensuring optimal depth of field, resolution, image contrast and clarity. The I/O port can be used for notification to an alarm panel or control of a relay. Axis Zipstream technology reduces bandwidth and storage requirements. The outdoor-ready camera comes with either a wide or a tele lens.

- > Slim, bullet camera
- > Built-in IR LEDs with OptimizedIR
- > Two lens alternatives
- > HDTV 1080p at up to 50/60 fps
- > Axis Zipstream

Upgrades:

- Optimized IR- Automatically adapts exposure for best picture quality
- Wide or tele lens options
- Remote Zoom and Focus

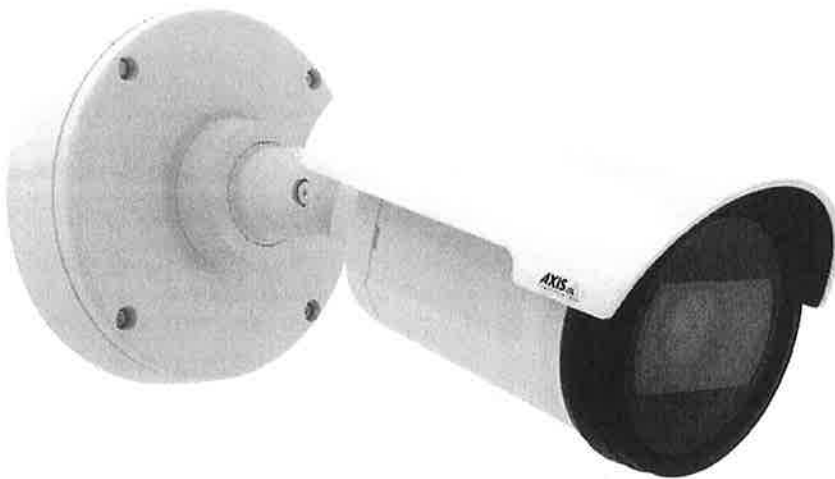

AXIS P1435-LE Network Camera

Camera	
Image sensor	Progressive scan CMOS 1/2.8"
Lens	3–10.5 mm, F1.4: Horizontal field of view: 95°–35° Vertical field of view: 51°–20° 10–22 mm, F1.85: Horizontal field of view: 34.5°–18° Vertical field of view: 20°–11° Varifocal, Remote focus and zoom, P-Iris control, IR corrected
Day and night	Automatically removable infrared-cut filter
Minimum illumination	3–10.5 mm, at 50 IRE F1.4: Color: 0.12 lux at 30 fps Color: 0.24 lux at 60 fps B/W: 0.01 lux at 30 fps B/W: 0.02 lux at 60 fps 10–22 mm, at 50 IRE F1.85: Color: 0.16 lux at 30 fps Color: 0.32 lux at 60 fps B/W: 0.02 lux at 30 fps B/W: 0.03 lux at 60 fps 0 lux with IR illumination on
Shutter time	1/66500 to 2 s
Video	
Video compression	H.264 High, Main and Baseline profiles (MPEG-4 Part 10/AVC) Motion JPEG
Resolution	HDTV 1080p 25/30 fps (WDR): 1920x1080 to 160x90 HDTV 1080p 50/60 fps (no WDR): 1920x1080 to 160x90 Meets relevant parts of SMPTE 274M (HDTV 1080p)
Frame rate	Up to 50/60 fps (50/60 Hz, no WDR) in all resolutions
Video streaming	Multiple, individually configurable streams in H.264 and Motion JPEG Axis Zipstream technology in H.264 Controllable frame rate and bandwidth VBR/ABR/MBR H.264
Multi-view streaming	Up to 8 individually cropped out view areas
Image settings	Manual shutter time, Compression, Color, Brightness, Sharpness, White balance, Exposure control, Exposure zones, Fine tuning of behavior at low light, Text and image overlay, Privacy masks, IR illumination Wide Dynamic Range – Forensic Capture: Up to 120 dB depending on scene, Mirroring of images Rotation: 0°, 90°, 180°, 270°, including Corridor Format
Pan/Tilt/Zoom	Digital PTZ
Network	
Security	Password protection, IP address filtering, HTTPS ^a encryption, IEEE 802.1X (EAP-TLS) ^a network access control, digest authentication, user access log, brute force delay protection, signed firmware
Supported protocols	IPv4, IPv6 USGv6, HTTP, HTTPS ^a , SSL/TLS ^a , QoS Layer 3 DiffServ, FTP, CIFS/SMB, SMTP, Bonjour, UPnP TM , SNMP v1/v2c/v3 (MIB-II), DNS, DynDNS, NTP, RTSP, RTP, SRTP, SFTP, TCP, UDP, IGMP, RTCP, ICMP, DHCP, ARP, SOCKS, SSH LLDP
System integration	
Application Programming Interface	Open API for software integration, including VAPIX [®] and AXIS Camera Application Platform; specifications at axis.com AXIS Video Hosting System (AVHS) with One-Click Connection ONVIF [®] Profile G, ONVIF [®] Profile S and ONVIF [®] Profile T, specification at onvif.org
Analytics	Included AXIS Video Motion Detection Supported AXIS Digital Autotracking, AXIS Perimeter Defender, AXIS Cross Line Detection Support for AXIS Camera Application Platform enabling installation of third-party applications, see axis.com/acap
Event triggers	Analytics Detectors: Day/Night Mode, Live Stream Accessed, Tampering Hardware: Network, Temperature

	Input Signal: Manual Trigger, Virtual Inputs Storage: Disruption, Recording System: System Ready Time: Use Schedule, Recurrences
Event actions	File upload: FTP, SFTP, HTTP, HTTPS network share and email Notification: email, HTTP, HTTPS and TCP and SNMP trap External output activation Video recording to edge storage Pre- and post-alarm video buffering WDR mode PTZ control, Overlay text IR illumination
Built-in installation aids	Pixel counter, Remote zoom (3–10.5 mm 3.5x optical, 10–22 mm 2x optical), Remote focus
Data streaming	Event data
General	
Casing	IP66, IP67- and NEMA 4X-rated casing (polyester polycarbonate blend)
Sustainability	PVC free
Memory	512 MB RAM, 256 MB Flash
Power	Power over Ethernet IEEE 802.3af/802.3at Type 1 Class 3 Typical: 4.6 W, max 11 W
Connectors	Shielded RJ45 10BASE-T/100BASE-TX PoE I/O: 4-pin terminal block for 1 alarm input and 1 output
IR illumination	Optimized IR, highly efficient LEDs with adjustable intensity and angle of illumination. 3–10.5 mm: Range up to 30 m (98 ft) 10–22 mm: Range up to 50 m (164 ft)
Storage	Support for microSD/microSDHC/microSDXC card Support for SD card encryption Support for recording to network-attached storage (NAS) For SD card and NAS recommendations see axis.com
Operating conditions	-30 °C to 55 °C (-22 °F to 131 °F) -30 °C to 60 °C (-22 °F to 140 °F) when IR LEDs are off Humidity 10–100% RH (condensing)
Storage conditions	-40 °C to 65 °C (-40 °F to 149 °F) Humidity 5–95% RH (non-condensing)
Approvals	EN 55022 Class B, EN 61000-6-1, EN 61000-6-2, EN 50121-4, IEC 62236-4, EN 55024, FCC Part 15 Subpart B Class B, ICES-003 Class B, VCCI Class B, RCM AS/NZS CISPR 22 Class B, KCC KN22 Class B, KN24, IEC/EN/UL 60950-1, IEC/EN/UL 60950-22, EN 62471, IEC/EN 60529 IP66/IP67, IEC/EN 62262 IK08, NEMA 250 type 4X, IEC 60068-2-1, IEC 60068-2-2, IEC 60068-2-6, IEC 60068-2-27 Network NIST SP500-267 Safety IEC/EN/UL 60950-1, IEC/EN/UL 60950-22, IEC/EN 62471, IS 13252 Environment IEC 60068-2-1, IEC 60068-2-2, IEC 60068-2-6, IEC 60068-2-14, IEC 60068-2-27, IEC 60068-2-30, IEC 60068-2-78, IEC/EN 60529 IP66/IP67, IEC/EN 62262 IK08, NEMA 250 Type 4X, IEC 60825-1 Network NIST SP500-267
Weight	With weather shield: 800 g (1.75 lb)
Dimensions	Ø132 x 260 mm (Ø5 3/16 x 10 1/4 in)
Included accessories	Mounting bracket, Drill template, Installation Guide, Windows decoder 1-user license AXIS Weather Shield L
Optional accessories	AXIS T94F01M J-Box/Gang Box Plate AXIS T91A47 Pole Mount AXIS T94P01B Corner Bracket AXIS T94F01P Conduit Back Box AXIS Weather Shield K Axis PoE Midspans For more accessories, see axis.com

Video management software	AXIS Companion, AXIS Camera Station, Video management software from Axis' Application Development Partners available at axis.com/vms
Languages	English, German, French, Spanish, Italian, Russian, Simplified Chinese, Japanese, Korean, Portuguese, Traditional Chinese
Warranty	Axis 3-year warranty and AXIS Extended Warranty option, see axis.com/warranty

a. *This product includes software developed by the OpenSSL Project for use in the OpenSSL Toolkit (openssl.org/), and cryptographic software written by Eric Young (ey@cryptsoft.com).*

Environmental responsibility:
axis.com/environmental-responsibility

4 Way 15MP Multi-Position Data Sheet

*Not requested on bid

AXIS P3719-PLE Network Camera

15 MP multidirectional camera with IR for 360° coverage

AXIS P3719-PLE Network Camera is a compact 15-megapixel camera with four varifocal lenses (4 x Quad HD) enabling overview and detailed surveillance. With one IP address and one network cable, the four-cameras-in-one unit provides a flexible, cost-effective solution for multidirectional surveillance. 360° IR illumination and WDR provides excellent video quality in any light conditions. Each camera head can be individually positioned (pan, tilt, roll, and twist) along a circular track. Remote zoom and focus makes it easy to install and the clear cover, with no sharp edges, ensures undistorted views in all directions. The camera has an integrated weathershield.

- > 15 MP, 360° coverage with one IP address
- > 360° IR illumination
- > Compact, flexible and discreet
- > Remote zoom and focus
- > Zipstream

New Model for 2020

-Virtually the same as P3717-
PLE but with 15MP

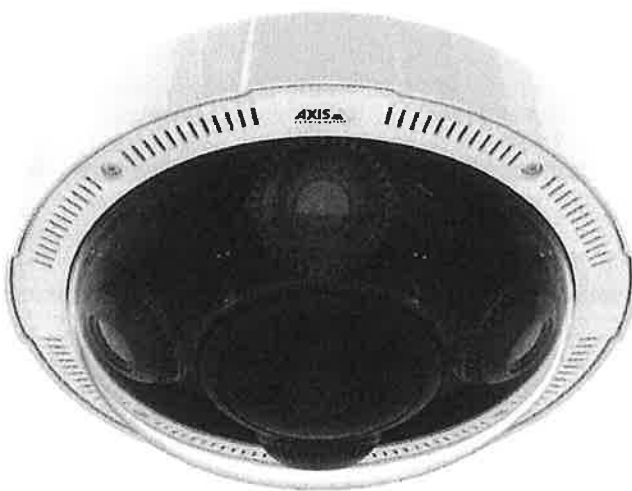

AXIS P3719-PLE Network Camera

Camera		Casing	IP66-, IP67-, NEMA 4X-rated, IK09 impact-resistant, aluminium and plastic casing with polycarbonate hard-coated dome, sunshield (PC/ASA) Color: white NCS S 1002-B For repainting instructions of casing and impact on warranty, contact your Axis partner.
Image sensor	4 x 1/2.5" progressive scan RGB CMOS	Mounting	Mounting bracket with junction box holes (double gang box, single gang box, 4" octagon junction box and 4" square junction box) 1/2" (M20) conduit side entry 3/4" (M25) conduit adapter included
Lens	Varifocal, 3–6 mm, F1.8–2.6 4 x 1440p capture mode: Horizontal field of view: 101°–49° Vertical field of view: 54°–29° Diagonal field of view: 116°–58° Motorized focus, motorized zoom	Sustainability	PVC free
Day and night	Automatically removable infrared-cut filter	Memory	1024 MB RAM, 512 MB Flash
Minimum illumination	Color: 0.20 lux at 50 IRE F1.8 B/W: 0.04 lux at 50 IRE F1.8, 0 lux with IR illumination on	Power	Power over Ethernet (PoE) IEEE 802.3at Type 2 Class 4 IR illumination on: class 4, typical 16.3 W, max 25.5 W IR illumination off: class 3, typical 10.7 W, max 25.5 W
Shutter time	1/66500 s to 1/5 s with 50/60 Hz	Connectors	RJ45 10BASE-T/100BASE-TX PoE Audio and I/O connectivity via AXIS T61 Audio and I/O Interfaces with portcast technology.
Camera angle adjustment	Pan ±90°, tilt +25 to +95°, rotation –5 to +95°, twist ±20°	IR illumination	Four individually controllable IR with power-efficient, long-life 850 nm IR LEDs Range of reach 15 m (50 ft) or more depending on the scene
Video		Storage	Support for microSD/microSDHC/microSDXC card Dual SD cards Support for SD card encryption Support for recording to network-attached storage (NAS) For SD card and NAS recommendations see axis.com
Video compression	H.264 (MPEG-4 Part 10/AVC) Main and High Profiles H.265 (MPEG-H Part 2)	Operating conditions	–30 °C to 50 °C (–22 °F to 112 °F) Humidity 10–100% RH (condensing)
Resolution	4 x 2560x1440 (4 x QHD 1440p) to 80x60	Storage conditions	–40 °C to 65 °C (–40 °F to 149 °F)
Frame rate	Up to 25/30 fps (50/60 Hz)	Approvals	EMC EN 55032 Class A, EN 50121–4, IEC 62236–4, EN 61000–3–2, EN 61000–3–3, EN 55024, EN 61000–6–1, EN 61000–6–2, FCC Part 15 Subpart B Class A, ICES-003 Class A, VCCI Class A, RCM AS/NZS CISPR 32 Class A Safety IEC/EN/UL 62368–1, IEC/EN/UL 60950–22, IEC 62471 Environment IEC 60068–2–1, IEC 60068–2–2, IEC 60068–2–6, IEC 60068–2–14, IEC 60068–2–27, IEC 60068–2–78, IEC/EN 60529 IP66/67, IEC/EN 62262 IK09, NEMA 250 Type 4X Network NIST SP500–267
Video streaming	Multiple, individually configurable streams in H.264 and H.265 Axis Zipstream technology in H.264 and H.265 Controllable frame rate and bandwidth VBR/ABR/MBR H.264	Dimensions	Height: 91.5 mm (3.6 in) ø 255 mm (10.04 in)
Image settings	Saturation, contrast, brightness, sharpness, WDR, white balance, exposure control, rotation: 0°, 90°, 180°, 270° including Corridor Format, dynamic text and image overlay, polygon privacy mask, compression	Weight	2.0 kg (4.4 lb)
Audio		Included accessories	RJ45 mounting tool, screw bit TR20, Installation guide, Windows® decoder 1-user license
Audio input/output	Two-way audio connectivity via optional AXIS T61 Audio and I/O Interfaces with portcast technology A 30 W midspan or higher between AXIS T61 Audio and I/O Interfaces and AXIS P3719-PLE is required.	Optional accessories	AXIS T94N01D Pendant Kit AXIS T94N01L Recessed Mount Axis mounts and cabinets For more accessories, see axis.com
Network		Video management software	AXIS Companion, AXIS Camera Station, video management software from Axis' Application Development Partners available on axis.com/vms
IP address	One IP address for all channels	Languages	English, Simplified Chinese, Traditional Chinese, French, German, Italian, Japanese, Korean, Polish, Portuguese, Russian, Spanish
Security	Password protection, IP address filtering, HTTPS ^a encryption, IEEE 802.1X (EAP-TLS) ^a network access control, digest authentication, user access log, centralized certificate management, brute force delay protection, signed firmware	Warranty	Axis 3-year warranty, see axis.com/warranty
Supported protocols	IPv4, IPv6 USGv6, HTTP, HTTPS ^a , SSL/TLS ^a , QoS Layer 3 DiffServ, FTP, CIFS/SMB, SMTP, Bonjour, UPnP™, SNMP v1/v2c/v3 (MIB-II), DNS, DynDNS, NTP, RTSP, RTP, SFTP, TCP, UDP, IGMP, RTCP, ICMP, DHCP, ARP, SOCKS, SSH	<p>a. This product includes software developed by the OpenSSL Project for use in the OpenSSL Toolkit. (openssl.org), and cryptographic software written by Eric Young (ey@cryptsoft.com).</p> <p>Environmental responsibility: axis.com/environmental-responsibility</p>	
System integration			
Application Programming Interface	Open API for software integration, including VAPIX® and AXIS Camera Application Platform; specifications at axis.com AXIS Video Hosting System (AVHS) with One-Click Connection ONVIF® Profile G, ONVIF® Profile S and ONVIF® Profile T, specification at onvif.org		
Analytics	Included AXIS Video Motion Detection, active tampering alarm Supported AXIS Guard Suite including AXIS Motion Guard, AXIS Fence Guard, and AXIS Loitering Guard Support for AXIS Camera Application Platform enabling installation of third-party applications, see axis.com/acap		
Event triggers	Detectors, hardware, input signal, storage, system, time, analytics, edge storage events		
Event actions	Day/night vision mode, overlay text, record video, send images, send notification, send SNMP trap, send video clip, status LED File upload: FTP, HTTP, HTTPS, network share, SFTP and email Notification: email, HTTP, HTTPS, TCP and SNMP trap		
Data streaming	Event data		
Built-in installation aids	Pixel counter, remote focus, remote zoom		
General			

HOWARD™



Response To

Hickman County BOE

Request for Proposal

For

“School Security Camera Systems”

Due Date: May 4, 2020 @ 10:45 AM

Presented By



HOWARD.edu

Our Vision and Strategy

We do IT



Letter of Transmittal

April 29, 2020

Hickman County Board of Education
114 North Central Avenue, Suite 203
Centerville, TN 37033

RE: "School Security Camera Systems"

Dear Hickman County Board of Education:

Howard Technology Solutions (a division of Howard Industries, Inc...**Federal ID Number 64-0466143** and SPIN 143022153) is pleased to offer a response to your RFP. Howard Technology Solutions has read and understands the RFP and are able to provide the services requested. Howard Technology Solutions, with its 40+ years of manufacturing experience, is well versed in the manufacturing and production of technology products and services.

Howard Technology Solutions, a division of Howard Industries, Inc., was established in 1998 with our parent company being founded in 1968. Howard Technology Solutions currently employs approximately 4,531 employees. Howard Technology Solutions is driven by helping our customers understand technology products and services that could benefit their organizations.

While Howard clients range from state governments and hospitals to the Kennedy Space Center, HOWARDedu focuses solely on the needs of K-12 schools and higher education facilities, supplying them with affordable, advanced technology—everything from distance learning and interactive 21st Century classroom products to network security and storage solutions.

The office location that will serve as the main point of contact is Howard Technology Solutions at 36 Howard Dr., Ellisville, MS 39437. (Phone) 601.425.3181; (Email) bids@howardcomputers.com. Your point of contact for this RFP is: Krystal Avery: Bids & Contract Manager, (Phone) 601.399.5831 (Fax) 601.399.5077 (Email) kavery@howard.com

36 Howard Drive • Ellisville, MS 39437
P.O. Box 1590 • Laurel, MS 39441

HOWARDTM
TECHNOLOGY SOLUTIONS

888.912.3151 general • 601.399.5077 fax
888.323.3151 technical support

www.Howard.com

A Division of Howard Industries, Inc.

Sales Contacts

Mike Scherer
TN K-12 Inside Sales
601.399.5055
mscherer@howard.com

Mike Mizer
TN K-12 Outside Sales
931.472.8740
mmizer@howard.com

Sincerely,

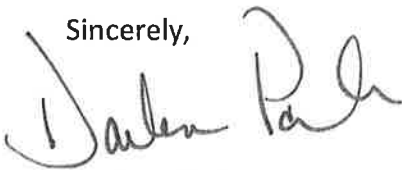

Darlene Parker
Bids Specialist
Phone: 601.425-3181
Fax: 601.399.5077
Email: bids@howardcomputers.com

Invitation To Bid

The Hickman County Finance Office is accepting sealed bids for **“School Security Camera Systems”**.

Specifications can be found on-line at: www.hickmank12.org/request-for-proposal.

Sealed bids must be mailed or hand delivered to the Hickman County Finance Office, 114 North Central Avenue, Suite 203, Centerville, TN 37033 and clearly marked on the outside of the envelope **“School Security Camera Systems”**. Bids will be opened on May 4, 2020 at 10:45 a.m. in the Finance Office.

The Hickman County Board of Education reserves the right to accept or reject any and all bids or parts of bids and waive any informalities that would prevent the acceptance of a better bid.

School Security Camera Systems - Hickman County Schools

Bid Form and Specifications/Scope of Work

The following Bid Form and Specifications/Scope of Work are to be used to submit bids by school.

Complete Pricing on this FORM and return with BID:

**Camera Types: (cost should include any related licensing)
(All cameras must be network capable)**

See attached Quotes

Camera Type	Price	Licensing
Single HD Dome Camera:	\$205.00	
Multi-position HD Camera: (minimum of 4 views)		
HD PTZ Camera:		
HD Bullet:		
POE Mini Switch		

Installation and all related materials

School	Installation Cost (including all related materials)	Other related Cost (please provide specifics on a separate sheet)
East Hickman High School	\$21,350.00	\$2,465.00 <i>Programming</i>
Hickman County High School	\$18,475.00	\$1,935.00

SPECIFICATIONS/SCOPE OF WORK

Bid can be awarded for individual schools or multiple schools

1 -- Scope of Work

1.1 Provide visualization of persons inside all school building hallways, office areas, and main entry points of the following schools: Hickman County High School and East Hickman High School. Minimum camera requirements are HD 1080p or comparable specifications. District goal is clear visualization.

1.2 Provide visualization of driveway entry and exit points as well as parking for all facilities as funds allow. District goal is to capture vehicle description and/or identification criteria such as license plates.

1.3 Appropriate VMS and storage should be included for each school facility, with storage located at the central office. Minimum storage capacity requirements are 30 days of storage. Accessible cloud base storage is acceptable.

1.4 Appropriate video management system (VMS) compatible with Axis Camera Station. **VMS must be network capable.**

1.5 If applicable provide VMS certification along with expiration date.

2 -- Maps and Layouts of Existing Facilities

2.1 Proposed Camera system placement and layout of facilities is available by written request to Brad Gilbert at brad.gilbert@hickmank12.org. Depending upon remaining budgets and cost considerations, Hickman County Schools (HCS) designated staff may consult with awarded contractor to add/delete/modify camera selection/location during pre-planning phase of contract. If the option to modify is taken, it shall not materially alter scope of work, especially the hardware/software package and work requirements.

2.2 Any system procured and installed during the course of this contract must be in compliance with all material elements of the specifications. Any changes to must be approved by HCS and documented in writing.

2.3 Map Notes - Maps provided under this RFP are not guaranteed for scale and only provide representation for bidding purposes. Maps are not guaranteed for 100 percent accuracy as there may have been minor alterations to some facilities that may or may not affect work.

3 -- Service and Support

Proposer shall include with response a detailed explanation of all material elements regarding service and support elements of this contract including, but not limited to:

- a) VMS - Please discuss service levels for software systems including response time, escalation procedures, and preventative problem identification capabilities.
- b) Protocol and Price for Upgrades and/or Updates
- c) All Licensing Considerations
- d) All initial fees and annual subscription costs
- e) System Troubleshooting Assistance and Protocol for Rest of System including Cameras, Servers, ancillary systems.

4 -- Installation

Please discuss all pertinent elements and methodologies of installation including but not limited to:

- a) Pre-planning
- b) Sourcing/Product Acquisition
- c) Delivery/Set-up/Storage/Security
- d) Installation
- i) Schedule - Please include your understanding of working in occupied K-12 space, school hours, administration support and partnership, safety, clean-up, and potential schedule. System "Start-up", Testing, and Quality Control
- ii) All work should be completed after school hours of operation or during school breaks
- iii) Inventory list of cameras and other equipment required in an excel format. File layout to be provided at a later time.

CONTRACTOR QUALIFICATIONS

Contractor shall submit a statement pertaining to the labor/staff that will be utilized in the performance of this contract. This statement should include experience, qualifications, training, etc.

- Tennessee State Contractor License is required
- VMS Certification - If applicable, be sure to identify which staff member(s), who will be assigned to this specific project, are certified.
- Single Point of Contact - Please identify and detail qualifications of the Single Point of

Contact from your company for this contract. While HCS may interact with multiple layers of staff, contractor must provide one point of accountability for all material aspects of the contract include installation, warranty, service, etc.

Sub - Contractor

Proposer shall disclose proposed use of contract labor in relation to labor performed by company staff. If contracted labor will be used, the proposer shall detail process for acquisition, vetting, supervision, and management during length of engagement. Proposer shall also certify the warranty and back all work performed by any sub-contracted labor and to be responsible for all communication as single point of contact.

Permits - If applicable, the Contractor will be required to be in compliance with all Federal, State, City, and local laws, rules and regulations and shall be responsible for all coordination and cost associated with license(s), permits; etc.

Phone: 1.888.912.3151
Fax: 1.601.399.5077
Online: www.howardcomputers.com



Howard Computers
P.O. Box 1588
Laurel, MS 39441

Online Quotation

Quote No:	MS5 1015589.00	Quote Date:	April 24, 2020
Customer Name:	Brad Gilbert	Phone Number:	9317293391
Company Name:	Hickman County Schools	Fax Number:	
Quote Name:	OPP-8685 - CCTV RFP - EHHS		

Item 1

Category	Description	Qty.	Unit Price	Ext. Price
System Type:	Accessories			
1:	AXIS Camera Station S1148 Recorder - NVR - 48 channels - 8 x 8 TB - networked - 2U - rack-mountable	1	\$10,615.00	\$10,615.00
2:	AXIS M3065-V - Network surveillance camera - dome - dustproof / waterproof / vandal-proof - color (Day&Night) - 1920 x 1080 - 720p, 1080p - fixed iris - fixed focal - HDMI - LAN 10/100 - MJPEG, H.264, H.265, MPEG-4 AVC - PoE	50	\$205.00	\$10,250.00
3:	AXIS TM3101 Pendant Mount - Camera mount - ceiling mountable, wall mountable - indoor - white - for AXIS M2025, M2026, M3044, M3045, M3046, M3047, M3048, M3106, M4206, P3904, P3905, P3915	12	\$31.00	\$372.00
4:	RackSolutions - Rack rail kit - 19"	1	\$128.00	\$128.00
5:	AXIS Camera Station - (v. 5) - Core Device license - ESD - Win	2	\$60.00	\$120.00
	Sub-Total:			\$21,485.00
	Parts & Accessories Shipping:			\$70.00
	Taxes:			Tax Exempt
	Total for Item 1:			\$21,555.00

This quote will expire May 24, 2020.
To expedite your order, please include your quote number with your Purchase Order.

Item 2

Category	Description	Qty.	Unit Price	Ext. Price
System Type:	Accessories			
1:	Installation for OPP-8685 Hickman County TN EHHS Cameras V2	1	\$21,350.00	\$21,350.00
2:	Programming for OPP-8685 Hickman County TN EHHS Cameras V2	1	\$2,465.00	\$2,465.00
3:	(Optional) Standard Service Contract for Services Rendered - this option will extend the installation warranty from a period of 90 days until a period of 1 year from the finish of the installation.	1	\$4,595.00	\$4,595.00

Sub-Total: \$28,410.00

Parts & Accessories Shipping: Included

Taxes: Tax Exempt

Total for Item 2: \$28,410.00

**This quote will expire May 24, 2020.
To expedite your order, please include your quote number with your Purchase Order.**

Total for all pre-configured items

Sub-Total: \$49,895.00

Parts & Accessories Shipping: \$70.00

Taxes: Tax Exempt

Total: \$49,965.00

Notes:

Pricing and availability subject to change without notice. Packaging, Shipping, and Handling fees are not included unless specifically stated. Prices and lease payments do not include applicable taxes. Ship dates are approximations and are not guarantees. Quick ship items not available in Alaska, Hawaii, or outside the United States. Specific state laws may affect shipment of products.

Howard reserves the right to charge a 25% restocking fee for cancellation of a purchase order after Howard has commenced fulfillment of the order. Howard may, with notice, cancel any purchase order at any time without any liability to the Purchaser. Howard reserves the right to charge the Purchaser full purchase price for delaying shipment of a purchase order for an extended period of time which then results in the cancellation of said order.

Given the current uncertainties related to international trade, Howard hereby reserves the right to unilaterally revise the prices quoted herein in the event its manufacturing or procurement costs for such goods increase due to the imposition by the United States or any other country of new or higher tariff(s) or of any other similar tax, fee or charge.

If Purchaser fails to pay any invoice in full within the time quoted herein, Howard may, without notice, accelerate the due date of all outstanding invoices and require that all outstanding invoices, including any interest thereon, be immediately due and payable in full.

Howard's product warranties and return policies and related information, which are available at <https://www.howardcomputers.com/support/warranties.cfm> and <https://www.howardcomputers.com/support/returnpolicy.cfm>, are fully adopted and incorporated herein by reference. These may also be obtained by calling 1-888-912-3151 or emailing webmaster@howardcomputers.com.

THIS QUOTATION IS EXPRESSLY LIMITED TO, AND EXPRESSLY MADE CONDITIONAL ON, PURCHASER'S ACCEPTANCE OF THE TERMS SET FORTH OR INCORPORATED HEREIN; HOWARD OBJECTS TO ANY DIFFERENT OR ADDITIONAL TERMS.

Phone: 1.888.912.3151
Fax: 1.601.399.5077
Online: www.howardcomputers.com



Howard Computers
P.O. Box 1588
Laurel, MS 39441

Online Quotation

Quote No: MS5 1015594.00 **Quote Date:** April 24, 2020
Customer Name: Brad Gilbert **Phone Number:** 9317293391
Company Name: Hickman County Schools **Fax Number:**
Quote Name: OPP-8685 - CCTV RFP - HCHS

Item 1

Category	Description	Qty.	Unit Price	Ext. Price
System Type:	Accessories			
1:	AXIS Camera Station S1148 Recorder - NVR - 48 channels - 8 x 8 TB - networked - 2U - rack-mountable	1	\$10,615.00	\$10,615.00
2:	AXIS M3065-V - Network surveillance camera - dome - dustproof / waterproof / vandal-proof - color (Day&Night) - 1920 x 1080 - 720p, 1080p - fixed iris - fixed focal - HDMI - LAN 10/100 - MJPEG, H.264, H.265, MPEG-4 AVC - PoE	41	\$205.00	\$8,405.00
3:	AXIS TM3101 Pendant Mount - Camera mount - ceiling mountable, wall mountable - indoor - white - for AXIS M2025, M2026, M3044, M3045, M3046, M3047, M3048, M3106, M4206, P3904, P3905, P3915	15	\$31.00	\$465.00
4:	RackSolutions - Rack rail kit - 19"	1	\$128.00	\$128.00
			Sub-Total:	\$19,613.00
			Parts & Accessories Shipping:	\$65.00
			Taxes:	Tax Exempt
			Total for Item 1:	\$19,678.00

This quote will expire May 24, 2020.
To expedite your order, please include your quote number with your Purchase Order.

Item 2

Category	Description	Qty.	Unit Price	Ext. Price
System Type:	Accessories			
1:	Installation for OPP-8685 Hickman County TN HCHS Cameras V2	1	\$18,475.00	\$18,475.00
2:	Programming for OPP-8685 Hickman County TN HCHS Cameras V2	1	\$1,935.00	\$1,935.00
3:	(Optional) Standard Service Contract for Services Rendered - this option will extend the installation warranty from a period of 90 days until a period of 1 year from the finish of the installation.	1	\$3,950.00	\$3,950.00

Sub-Total: \$24,360.00

Parts & Accessories Shipping: Included

Taxes: Tax Exempt

Total for Item 2: \$24,360.00

**This quote will expire May 24, 2020.
To expedite your order, please include your quote number with your Purchase Order.**

Total for all pre-configured items

Sub-Total: \$43,973.00

Parts & Accessories Shipping: \$65.00

Taxes: Tax Exempt

Total: \$44,038.00

Notes:

Pricing and availability subject to change without notice. Packaging, Shipping, and Handling fees are not included unless specifically stated. Prices and lease payments do not include applicable taxes. Ship dates are approximations and are not guarantees. Quick ship items not available in Alaska, Hawaii, or outside the United States. Specific state laws may affect shipment of products.

Howard reserves the right to charge a 25% restocking fee for cancellation of a purchase order after Howard has commenced fulfillment of the order. Howard may, with notice, cancel any purchase order at any time without any liability to the Purchaser. Howard reserves the right to charge the Purchaser full purchase price for delaying shipment of a purchase order for an extended period of time which then results in the cancellation of said order.

Given the current uncertainties related to international trade, Howard hereby reserves the right to unilaterally revise the prices quoted herein in the event its manufacturing or procurement costs for such goods increase due to the imposition by the United States or any other country of new or higher tariff(s) or of any other similar tax, fee or charge.

If Purchaser fails to pay any invoice in full within the time quoted herein, Howard may, without notice, accelerate the due date of all outstanding invoices and require that all outstanding invoices, including any interest thereon, be immediately due and payable in full.

Howard's product warranties and return policies and related information, which are available at <https://www.howardcomputers.com/support/warranties.cfm> and <https://www.howardcomputers.com/support/returnpolicy.cfm>, are fully adopted and incorporated herein by reference. These may also be obtained by calling 1-888-912-3151 or emailing webmaster@howardcomputers.com.

THIS QUOTATION IS EXPRESSLY LIMITED TO, AND EXPRESSLY MADE CONDITIONAL ON, PURCHASER'S ACCEPTANCE OF THE TERMS SET FORTH OR INCORPORATED HEREIN; HOWARD OBJECTS TO ANY DIFFERENT OR ADDITIONAL TERMS.

STATE OF TENNESSEE
DEPARTMENT OF
COMMERCE AND INSURANCE

HOWARD INDUSTRIES, INC

67207
ID NUMBER: 67207
LIC STATUS: ACTIVE
EXPIRATION DATE: September 30, 2021

BOARD FOR LICENSING CONTRACTORS
CONTRACTOR

THIS IS TO CERTIFY THAT ALL REQUIREMENTS
OF THE STATE OF TENNESSEE HAVE BEEN MET

HOWARD INDUSTRIES, INC
PO BOX 1590
LAUREL, MS 39441

State of Tennessee 36265b 1930237

BOARD FOR LICENSING CONTRACTORS
CONTRACTOR
HOWARD INDUSTRIES, INC

This is to certify that all requirements of the State of Tennessee have been met.

ID NUMBER: 67207
LIC STATUS: ACTIVE
EXPIRATION DATE: September 30, 2021
UNLIMITED; S-Audio Vis Sys; S-Low Voltage E

IN-1313
DEPARTMENT OF
COMMERCE AND INSURANCE



East Hickman High School Upper Level

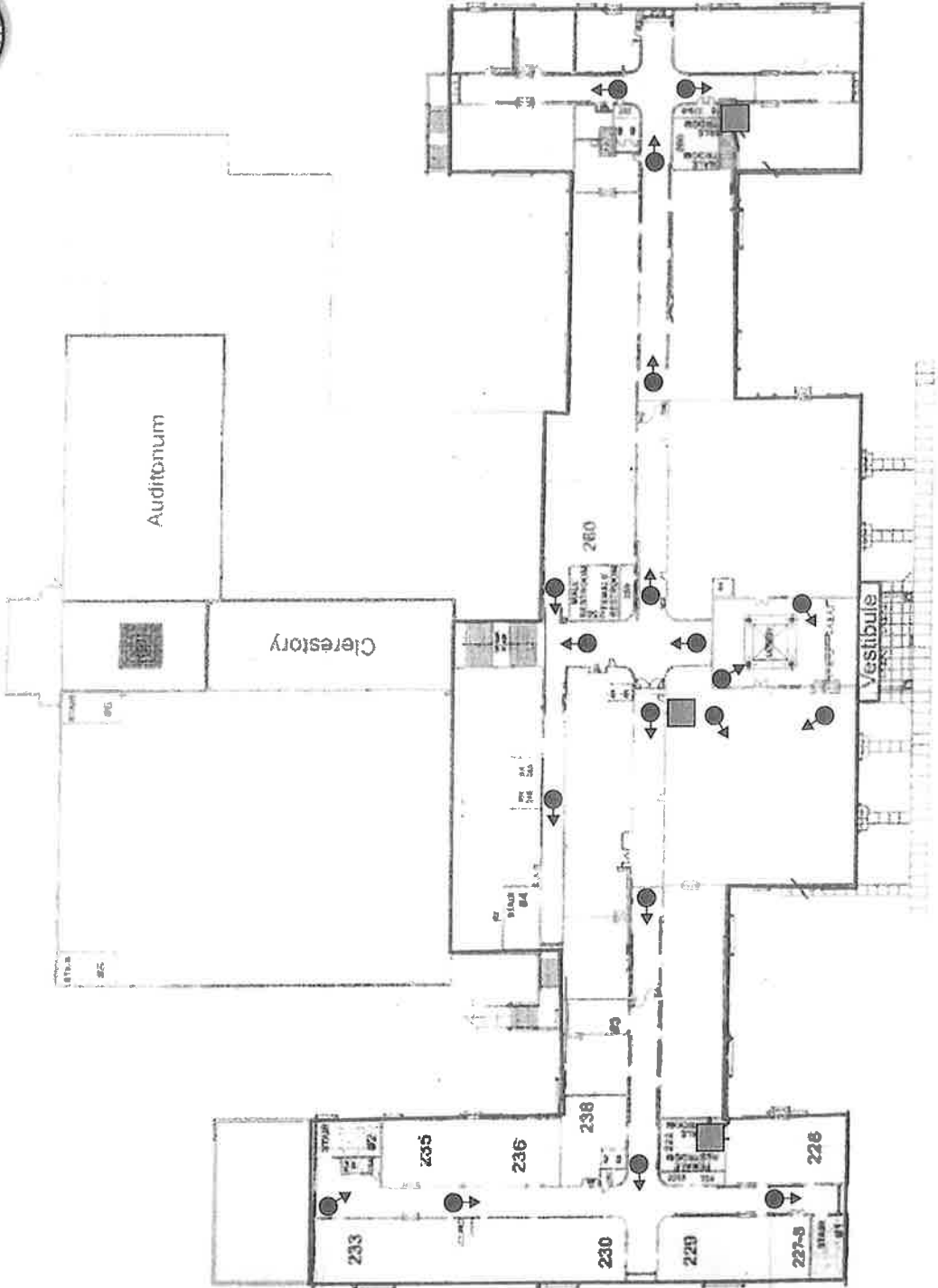

- Indoor Dome IP Camera (QTY 19)
- MDF/IDF Location (3)

East Hickman High School Lower Level

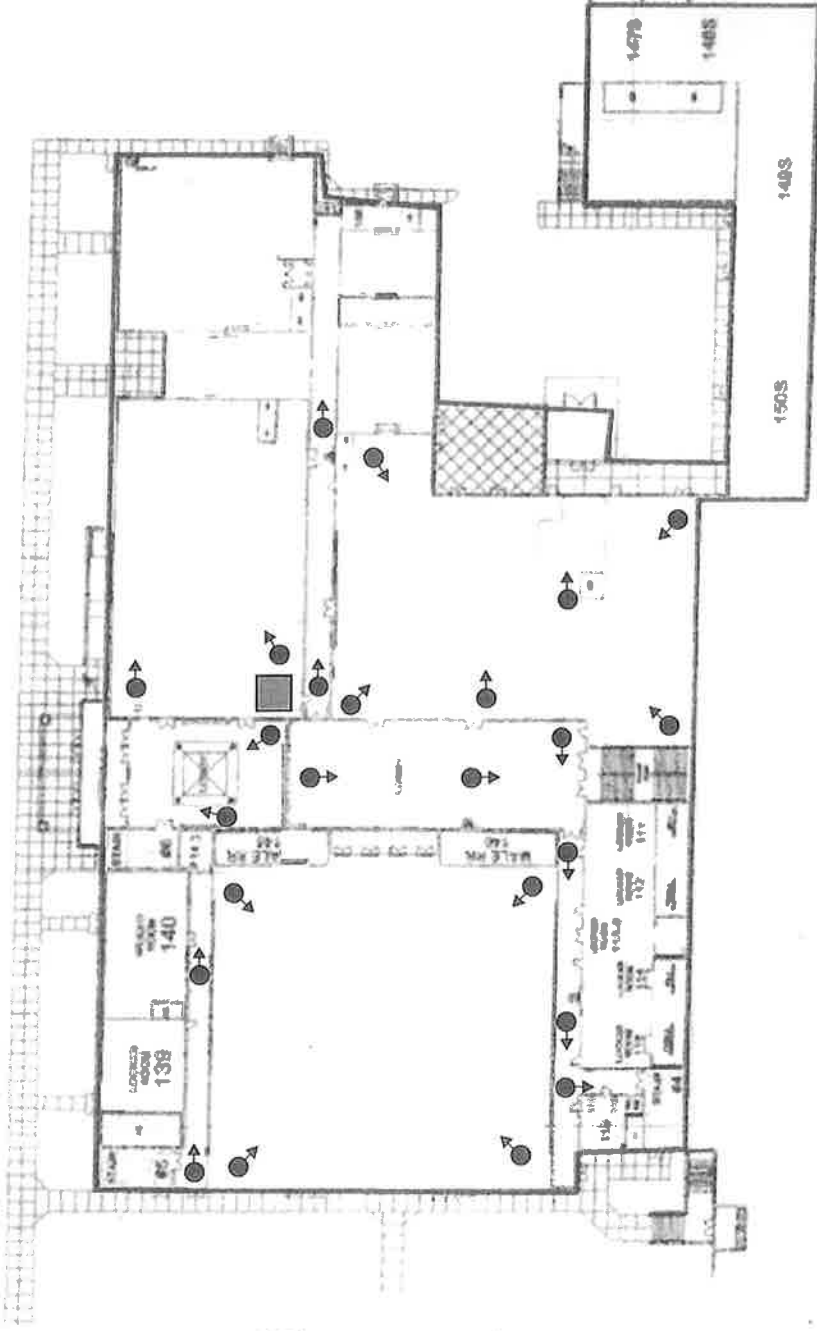
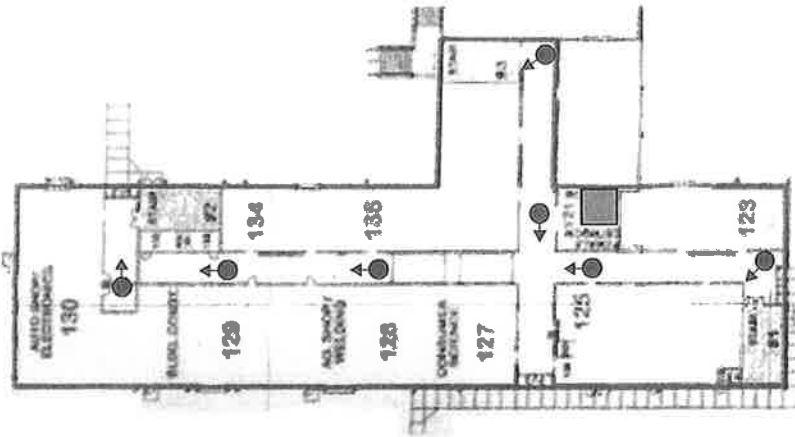

● Indoor Dome IP Camera (31)

■ MDF/IDF Location (2)

HOWARDTM
TECHNOLOGY SOLUTIONS
PHYSICAL SECURITY

Hickman County High School

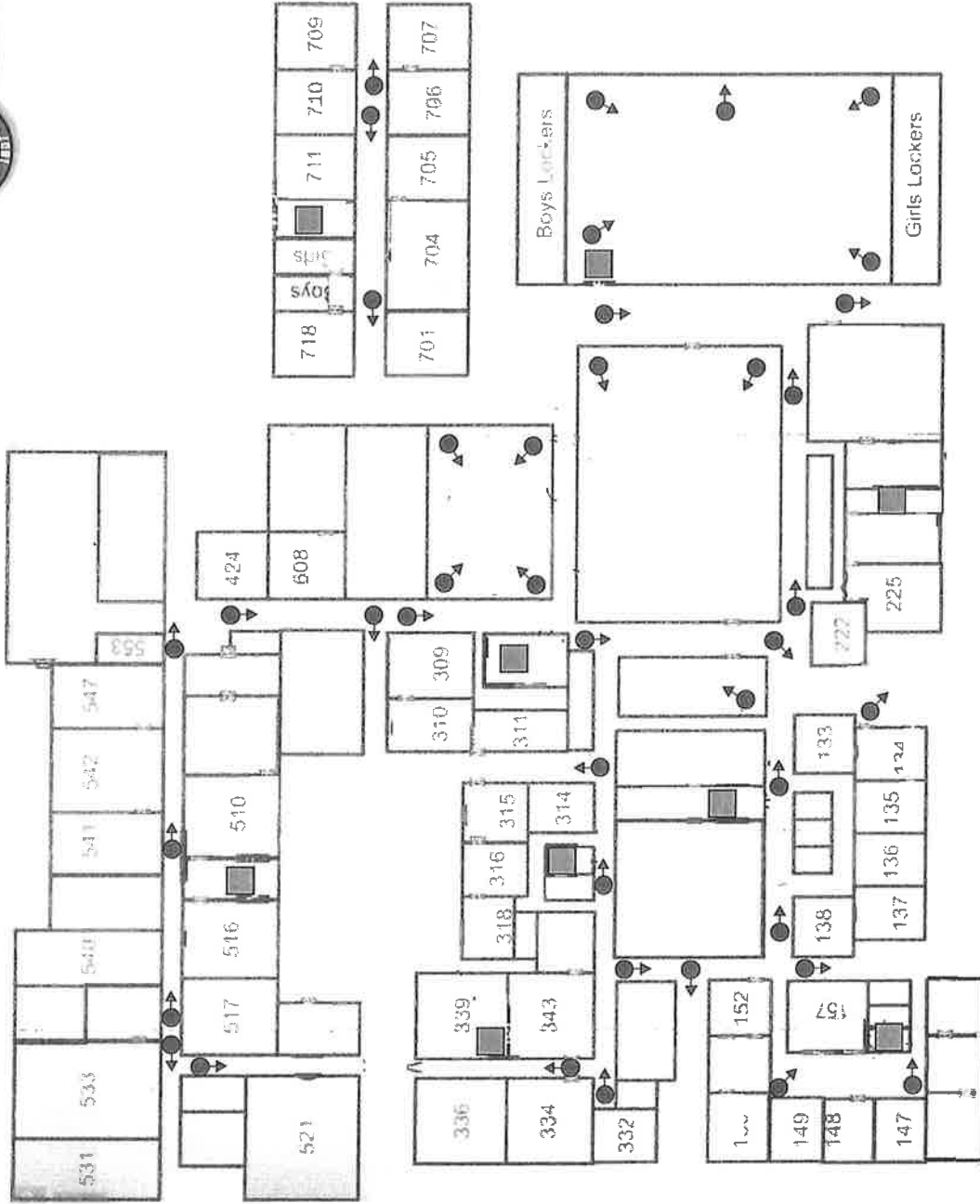

- Indoor Dome IP Camera (41)
- MDF/IDF Location

The logo for EduTech, featuring the word "EDUTECH" in a stylized, metallic, blocky font. The letters are white with a dark outline, set against a dark background. The logo is enclosed in a circular frame with concentric lines, suggesting a globe or a signal. The background of the logo area is black.

1150 Henry Street, Suite 4
Dyersburg, TN 38024
Phone: 800-324-1105
Cell: 731-694-1092
Fax: 731-285-0887
don@edutech-tn.com

May, 4, 2020

To: Hickman County Board Of Education

Re: School Security Camera Bid

Attn: Brad Gilbert

Brad,

I have attached the proposal for the Camera System Bid. I have given you two options to review. Option 1 is the Trueview camera system. I have priced the Cameras an NVR's which includes the VMS software at no additional charge. These cameras have a higher resolution than the Axis cameras that you requested. There is no additional license cost and the VMS software has unlimited licenses. I also quoted the Axis cameras that you requested. The Axis option includes the cameras and installation on existing Axis camera station.

EduTech Inc. has been working with K-12 Schools throughout the state of TN since 1993. I am one of the owners and live Fairview, TN. I will be over this project. EduTech Inc. employees complete all the installations and we do not use any subcontractors.

We really appreciate the opportunity to bid. Please review and let me know if you have any questions.

Sincerely,

A handwritten signature in black ink, appearing to read "Don Smith". The signature is fluid and cursive, written over a white background.

Don Smith
EduTech Inc.
7403 King Rd.
Fairview, TN 37062

Home Office:
1150 Henry St. Suite 4
Dyersburg, TN 38024

School Security Camera Systems - Hickman County Schools

Bid Form and Specifications/Scope of Work

The following Bid Form and Specifications/Scope of Work are to be used to submit bids by school.

Complete Pricing on this FORM and return with BID:

**Camera Types: (cost should include any related licensing)
 (All cameras must be network capable)**

Option 1: Trueview Camera System

Camera Type	Price	Licensing
Single HD Dome Camera:	Trueview TI-NC4053VDL \$200.00 5MP 2.8-12mm Mounts on Wall or Ceiling	No additional license needed.
Multi-position HD Camera: (minimum of 4 views)	Trueview DS-2CD6986F \$1,295.00 8MP Panoramic Camera with Wall Mount	No additional license needed.
HD PTZ Camera:	Trueview NP112-IR/25X \$695.00 25X with Wall Mount	No additional license needed.
HD Bullet:	Trueview TI-NC4053VDL \$200.00 5MP 2.8-12mm Mounts on Wall or Ceiling	No additional license needed.
POE Mini Switch	4 Port POE \$65.00	N/A
	8 Port POE \$125.00	N/A
	24 Port POE \$425.00	N/A
Cat. 6 Network Drop (Riser)	\$150.00	N/A

Installation and all related materials

School	Installation Cost (including all related materials)	Other related Cost (please provide specifics on a separate sheet)
East Hickman High School	\$95.00 Per Camera	N/A
Hickman County High School	\$95.00 Per Camera	N/A
Options For NVRS and VMS		
32 Channel NVR with 10TB HD	Trueview NRA-710-32 \$1,995.00	N/A
64 Channel NVR with 20TB HD	Trueview NRA710-64 \$2,995.00	N/A
VMS Software	Trueview VMS-4200	No additional cost Unlimited Lic.

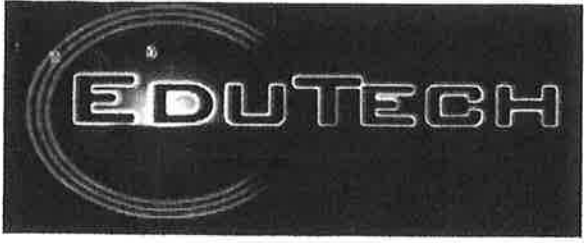

1150 Henry Street, Suite 4
 Dyersburg, TN 38024
 Phone: 800-324-1105
 Cell: 731-694-1092
 Fax: 731-285-0887
 don@edutech-tn.com

School Security Camera Systems - Hickman County Schools

Bid Form and Specifications/Scope of Work

The following Bid Form and Specifications/Scope of Work are to be used to submit bids by school.

Complete Pricing on this FORM and return with BID:

**Camera Types: (cost should include any related licensing)
 (All cameras must be network capable)**

Option 2: Axis Cameras

Camera Type	Price	Licensing
Single HD Dome Camera:	Axis M3065V \$286.00	Axis ACS Core Lic. \$80.00
Multi-position HD Camera: (minimum of 4 views)	Axis P3737-PLE4 \$1,345.00 Axis PTZ Wall Mount \$240.00	Axis ACS Core Lic. \$80.00
HD PTZ Camera:	Axis M5525-E PTZ \$750.00	Axis ACS Core Lic. \$80.00
HD Bullet:	Axis M2025LE \$326.00	Axis ACS Core Lic. \$80.00
POE Mini Switch	4 Port POE \$65.00	N/A
	8 Port POE \$125.00	N/A
	24 Port POE \$425.00	N/A
Cat. 6 Network Drop (Riser)	\$150.00	N/A

Installation and all related materials

School	Installation Cost (including all related materials)	Other related Cost (please provide specifics on a seperate sheet)
East Hickman High School	\$95.00 Per Camera	N/A
Hickman County High School	\$95.00 Per Camera	N/A
Option 1 Bid is for installation Axis Cameras and Licenses on existing Axis Camera Stations. Does not include any additional VMS Software		

TI-NC405-3VDZ

5 MP UHD IR Dome 4X Motorized Lens IP Camera



KEY FEATURES

- 1/2.8" Sony IMX335 Low light CMOS sensor
- Max. 5MP resolution 2592 x 1944 output
- low illumination 0.01Lux
- Day/Night (ICR), AWB, 2D/3D-DNR, IR-CUT
- D-WDR, Motion Detection, Privacy Mask, Mirror, Flip
- RTSP and Onvif 17.06 compatible
- H.265/H.264 dual-stream media server
- Lightning protection 4000V
- Strong water-proof housing, IP66
- 24 Array IR Leds , IR distance 100 ft
- HD 2.8-12mm AF lens

TI-NC405-3VDZ		
Camera	Image sensor	1/2.8" Sony IMX335 CMOS
	Effective Pixels	2592(H)x1944 (V)
	Electronic Shutter	AUTO, 1/25s ~ 1/100000s
	Min. Illumination	0.01Lux@F1.2(AGC ON), 0Lux IR on
	Day/Night	Auto/Color/(B/W)/Timing
	WDR	Digital WDR
	White Balance	Auto
	Other	AGC,2/3 DNR,Motion Detection, Privacy Mask, Mirror, Flip
	Video Standard	H.265/H.264
	Video Resolution	MainStream: 15fps@5MP(2592x1944),25fps@4MP/3MP,30fps@1080P/720P Sub stream: D1/VGA(640x480)/360P/QVGA@25fps
	Video Bitrate	512Kbps - 6Mbps, VBR/CBR
	Audio Standard	G.711-u/G.711-a
	Network Services	IR LED
IR Distance		100ft
Focal Length		2.8 – 12mm AF lens
Protocol		RTSP/FTP/DHCP/DDNS/NTP/SMTP/NFS
P2P		Yes
Web		IE , firefox 32bit ESR
Media		CMS, Android, IOS
General	ONVIF	17.06 compatible
	Network Port	1-RJ45, 100Mbps, POE optional
	Power Supply	12 VDC ± 10%
	Power Consumption	< 5 W
	Operating Temp	-22°F – 140°F

DIMENSIONS

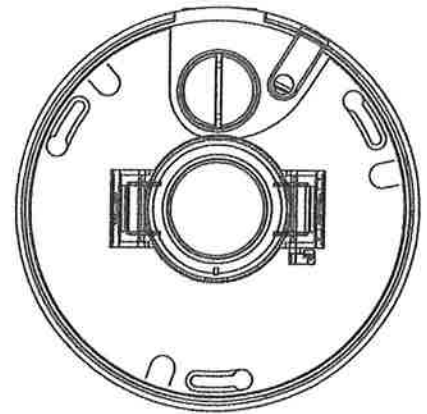
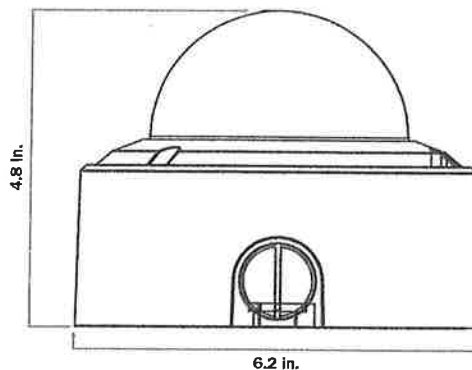

TI-NC405-3VBZ

5 MP UHD IR Dome 4X Motorized Lens IP Camera

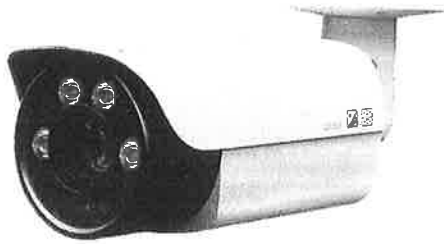
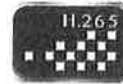

KEY FEATURES

- 1/2.8" Sony IMX335 Low light CMOS sensor
- Max. 5MP resolution 2592 x 1944 output
- low illumination 0.01Lux
- Day/Night (ICR), AWB, 2D/3D-DNR, IR-CUT
- D-WDR, Motion Detection, Privacy Mask, Mirror, Flip
- RTSP and Onvif 17.06 compatible
- H.265/H.264 dual-stream media server
- Lightning protection 4000V
- Strong water-proof housing, IP66
- 4pcs Array IR Leds, IR distance 220ft
- HD 2.8-12mm AF lens

TI-NC405-3VBZ		
Camera	Image sensor	1/2.8" Sony IMX335 CMOS
	Effective Pixels	2592(H)×1944 (V)
	Electronic Shutter	AUTO, 1/25s ~ 1/100000s
	Min. Illumination	0.01Lux@F1.2(AGC ON), 0Lux IR on
	Day/Night	Auto/Color/(B/W)/Timing
	WDR	Digital WDR
	White Balance	Auto
	Other	AGC,2/3 DNR,Motion Detection, Privacy Mask, Mirror, Flip
	Video Standard	H.265/H.264
	Video Resolution	MainStream: 15fps@5MP(2592x1944),25fps@4MP/3MP,30fps@1080P/720P Sub stream: D1/VGA(640x480)/360P/QVGA@25fps
	Video Bitrate	512Kbps - 6Mbps, VBR/CBR
	Audio Standard	G.711-u/G.711-a
	Network Services	IR LED
IR Distance		220ft
Focal Length		2.8 - 12mm
Protocol		RTSP/FTP/DHCP/DDNS/NTP/SMTP/NFS
P2P		Yes
Web		IE , firefox 32bit ESR
Media		CMS, Android, iOS
General	ONVIF	17.06 compatible
	Network Port	1-RJ45, 100Mbps, POE
	Power Supply	12 VDC ± 10%
	Power Consumption	< 5 W
	Operating Temp	-22°F - 140°F

DIMENSIONS

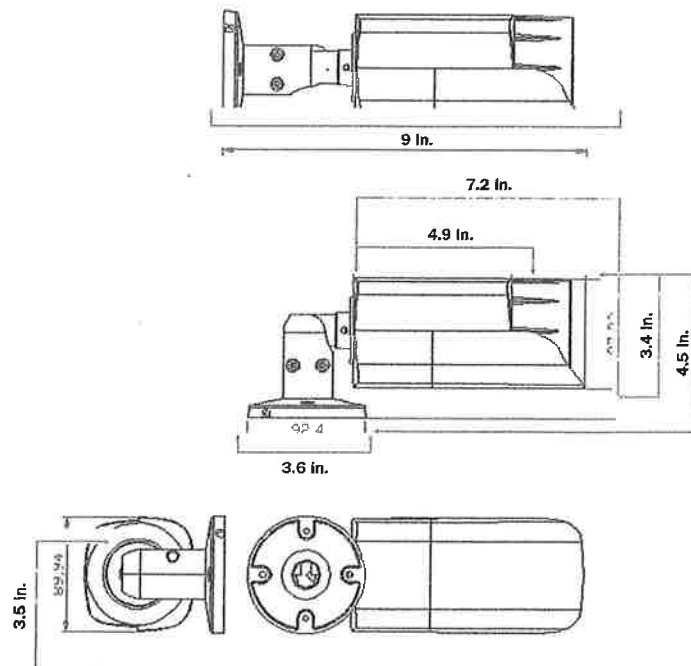

THK-2CD6986F-H

8MP Multi-Imager Panoramic Dome Camera



KEY FEATURES

- 1/1.9" Progressive Scan CMOS Sensor
- 4mm x 5mm Fixed Lens
- 180° Horizontal View
- Up to 8MP Resolution (4x2MP Sensors)
- Ultra-Low Light
- 3D DNR
- 128GB On-Board Storage slot
- 12 VDC / 24 VAC / PoE
- Audio/Alarm I/O
- IP66 Rated / IK10 Protection
- Heater and Fan

DIMENSION

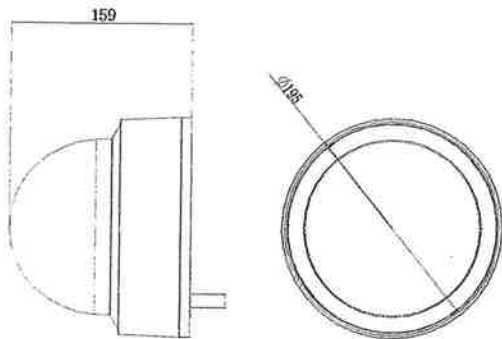

THK-2CD6986F-H		
Camera	Image Sensor	1/1.8" Progressive Scan CMOS
	Min. Illumination	Color: 0.002 lux @ (F1.4, AGC ON); B/W: 0 lux with IR
	Shutter Speed	1/25s to 1/100,000 s
	Slow Shutter	Support
	Lens	5mm x 4, pan: 180°, tilt: 78.4°
	Angle Adjustment	Pan: 0°~360°, Tilt: 45° ~ 90°
	Lens Mount	CS
	Day & Night	IR cut filter with auto switch/schedule/triggered by alarm
	WDR	Digital
Compression Standard	Video Compression	H.264+/H.264/MJPEG
	H.264 Type	Baseline/Main/High Profile
	Video Bit Rate	32 Kbps ~16 Mbps
	Dual Stream	Yes
Image	Audio Compression	G.711 (64 Kbps)/G.722.1 (16 Kbps)/G.726 (16 Kbps)/MP2L2 (32 to 192 Kbps)/AAC/PCM (16 to 64 Kbps)
	Max. Resolution	4096x1800
	Frame Rate	Mode 1: Main Stream: 30fps (4096x1800, 3840x1680), Sub Stream: 30fps (704x320) Mode 2: Main Stream: 24fps (2400x3840), 30fps (1200x1920), Sub Stream: 30fps (480x768, 320x512)
	Image Setting	Saturation, brightness, contrast, sharpness adjustable by client software or web browser
	Back Light Compensation	Yes, zone configured
	Region of Interest (ROI)	Yes, 4 regions
	Digital Noise Reduction	3D DNR
	Defog	Yes
	Network Storage	Network Storage
Alarm Trigger		Motion detection, tamper alarm, network disconnect, IP address conflict, storage exception
Protocols		TCP/IP, UDP, ICMP, HTTP, HTTPS, FTP, DHCP, DNS, DDNS, RTP, RTSP, RTCP, PPPoE, NTP, UPnP, SMTP, SNMP, IGMP, 802.1X, QoS, IPv6, Bonjour
Security		Three level user authentication, password authorization, HTTPS and SSH certificate, IEEE802.1X, basic and digest authentication, watermark, IP address filtering, log-in lockout
Standards		ONVIF (PROFILE S, PROFILE G), PSIA, CGI, ISAPI
Communication	Communication	1 RJ-45 10M/100M Ethernet port, RS-485 interface
	On-Board Storage	Built-in microSD / SDHC / SDXC slot, up to 128 GB
	Alarm	1x I/O (up to 24 VDC 1A or 110 VAC 500 mA)
	Audio	1x 3.5mm jack, audio in (mic in / line in)/ out interface
General	Operating Conditions	-30 °C ~ 60 °C (-22 °F ~ 140 °F), Humidity 95% or less (non-condensing)
	Power Supply	24 VAC ± 10%, PoE (802.3at) UL/cUL Listed
	Power Consumption	Max. 22W
	Protection Level	IEC60068-275Eh, 20I; EN50102, up to IK10, IP66
	Dimensions	Ø7.68" x 6.26" (Ø 195mm x 159mm)
Weight	2850g (6.28lbs)	

THK-NP112-IR/25X

2MP 25X Network IR PTZ Camera

TRUVIEW

HD

WDR

BLC

3D DNR

12VDC

H.265



KEY FEATURES

- 1/2.9" Progressive Scan CMOS
- Up to 1920x1080@30fps Resolution
- 25x Optical Zoom, 16x Digital Zoom
- WDR, HLC, BLC, 3D DNR, Defog, EIS, Regional Exposure, Regional Focus
- Up to 100m IR Distance
- 12VDC & PoE+ (802.3at, class 4)
- Support H.265+/H.265

DIMENSION

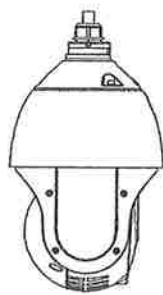
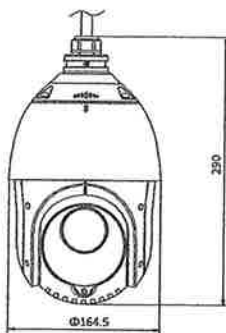

Unit: mm

THK-NP112-IR/25X		
Camera	Image Sensor	1/3" Progressive Scan CMOS
	Min. Illumination	Color: 0.005 lux@(F1.6, AGC ON), 0.001 lux@(F1.6, AGC ON), 0 lux with IR
	White Balance	Auto/Manual/ATW (Auto-tracking White Balance)/Indoor/Outdoor/ Fluorescent Lamp / Sodium Lamp
	AGC	Auto/Manual
	Shutter Time	50Hz: 1/1s to 1/30,000s; 60Hz: 1/1s to 1/30,000s
	Day & Night	IR Cut Filter
	Digital Zoom	16x
	Privacy Mask	24 programmable privacy masks
	Focus Mode	Auto / Semi-automatic / Manual
	WDR	120dB WDR
Lens	Focal Length	4.8mm to 120mm, 25x optical
	Zoom Speed	Approx. 3.6s (optical lens, wide-tele)
	FOV	Horizontal FOV: 57.6° to 2.5°(wide-tele), Vertical FOV: 34.4° to 1.4°(wide-tele), Diagonal FOV: 64.5° to 2.9°(wide-tele)
	Working Distance	10mm to 1500mm (wide-tele)
	Aperture Range	F1.6 to F3.5
IR	IR Distance	100M
	Smart IR	Support
PTZ	Movement Range (Pan)	360° endless
	Pan Speed	Configurable, from 0.1°/s to 80°/s, Preset speed: 80°/s
	Movement Range (Tilt)	From -15° to 90° (auto-flip)
	Proportional Zoom	Support
	Presets	300
	Patrol Scan	8 patrols, up to 32 preset for each patrol
	Pattern Scan	4 pattern scans, record time over 10 minutes for each scan
	Power-off Memory	Support
	Park Action	Preset/ Pattern Scan / Patrol Scan / Auto Scan / Tilt Scan / Random Scan / Frame Scan / Panorama Scan
	3D Positioning	Support
	PTZ Position Display	Support
	Preset Freezing	Support
	Scheduled Task	Preset/ Pattern Scan / Patrol Scan / Auto Scan / Tilt Scan / Random Scan / Frame Scan / Panorama Scan / Dome Reboot / Dome Adjust / Aux Output
Compression Standard	Video Compression	Main Stream: H.265+/H.265/H.264+/H.264, Sub Stream: H.265/MJPEG Third Stream: H.265/H.264/MJPEG
	H.264 Type	Baseline Profile / Main Profile / High Profile
	H.264+	Support
	H.265 Type	Baseline Profile / Main Profile / High Profile
	H.265+	Support
	Video Bit Rate	32 Kbps to 16384 Kbps
	Audio Compression	G.711alaw / G.711ulaw / G.722 / G.726 / MP2L2 / PCM
	Audio Bit Rate	G.711alaw / G.711ulaw: 64Kbps; G.722.1/G.726: 16Kbps; MP2L2/PCM: 32/64/128Kbps
SVC	Support	
Smart Feature	Basic Event	Motion Detection, Video Tampering Detection, Exception
	Smart Event	Intrusion Detection, Line Crossing Detection, Region Entrance Detection, Region Exiting Detection, Object Removal Detection, Unattended Baggage Detection
	Smart Record	ANR (Automatic Network Replenishment), Dual-VCA
	ROI	Main stream, Sub stream, Third stream respectively support four fixed areas

THK-NP112-IR/25X

2MP 25X Network IR PTZ Camera

TRUVIEW



THK-NP112-IR/25X

Image	Max. Resolution	1920 x 1080
	Main Stream	50Hz: 25fps (1920x1080, 1280x960, 1280x720); 50fps (1280x960, 1280x720) 60Hz: 30fps (1920x1080, 1280x960, 1280x720); 60fps (1280x960, 1280x720)
	Sub Stream	50Hz: 25fps (1920x1080, 1280x960, 1280x720, 704x576, 640x480, 352x288)
	Third Stream	50Hz: 25fps (1920x1080, 1280x960, 1280x720, 704x576, 640x480, 352x288) 60Hz: 30fps (1920x1080, 1280x960, 1280x720, 704x576, 640x480, 352x240)
	Image Enhancement	HLC / BLC / 3D DNR / Defog / EIS / Regional Exposure / Regional Focus
Network	Network Storage	Built-in memory card slot, support Micro SD/SDHC/SDXC, up to 256GB, NAS (NFS/SMB/CIFS), ANR
	Protocols	IPv4/IPv6, HTTP, HTTPS, 802.1x Qos, FTP, SMTP, UPnP, SNMP, DNS, DDNS, NTP, RTSP, RTCP, RTP, TCP/IP, UDP, IGMP, ICMP, DHCP, PPPoE, Bonjour
	API	Open-ended, support ONVIF, ISAPI, and CGI, support HIKVISION SDK and Third-Party Management Platform
	Simultaneous Live View	Up to 20 channels
	User / Host	Up to 32 users / 3 levels: Administrator, Operator, User
	Security Measures	User authentication(ID/PW), Host authentication (MAC address); HTTPS encryption, IEEE 802.1x port-based network access control, IP address filtering
	Client	iVMS-4200, iVMS-4500, iVMS-5200, Hik-Connect
	Web Browser	IE 8 to 11, Chrome 31.0 to 44, Firefox 30.0 to 51
Interface	Audio Interface	1-ch audio input and 1-ch audio output
	Network Interface	1 RJ45 10M/100M Ethernet Interface; PoE+ (802.3at, class 4)
General	Power	12 VDC & PoE+ (802.3at, class 4), Max.:18W (Max 7W for IR)
	Working Temperature	-30°C to 65°C (-22°F to 149°F)
	Working Humidity	≤90%
	Protection Level	IP66 Standar, TVS 4000V Lightning Protection, Surge Protection and Voltage Transient Protection
	Material	ADC12, PC, PC+10% GF
	Dimensions	Φ164.5mm x 290mm (Φ6.48" x 11.42")
	Weight	Approx. 2kg (4.41 lb)

ACCESSORIES

DS-JBP-W PTZ Wall Mount w/ Junction Box	DS-1602ZJ Wall Mount Bracket	DS-1661ZJ Pendant Mount Bracket	DS-1660ZJ Parapet Wall Mount	DS-CornerMt Corner Mount	DS-PoleMt Pole Mount

THK-NR710-32

32CH NVR with 8 hard drive bay



KEY FEATURES

- Dual-OS design to ensure high reliability of system running
- Up to 64-ch 12MP IP cameras can be connected
- H.264+ compression effectively reduces the storage space and costs by up to 50%
- Full channel recording at up to 12MP resolution
- HDMI1 Video output at up to 4K (3840x2160) resolution
- Up to 8 SATA interfaces and 1 eSATA interface connectable for recording and backup
- POS triggered recording and alarm
- Host and user authentication (up to 20 users)

PHYSICAL INTERFACES

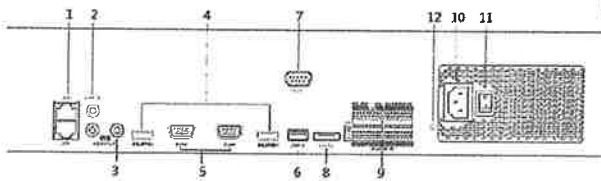

Index	Description	Index	Description
1	LAN1/LAN2 interface	7	RS-232 interface
2	LINE IN	8	eSATA interface
3	AUDIO OUT	9	Alarm In / Alarm Out
4	HDMI1 / HDMI2 interface	10	100 to 240 VAC power supply
5	VGA1 / VGA2 interface	11	Power Switch
6	USB 3.0 interface	12	GND

CMS (Remote Viewing Apps) — IVMS 4200 (PC / MAC)

Mobile App — Guarding Expert (ANDROID / iOS)

THK-NR710-32		
Video/ Audio Input	IP Video Input	32-ch Up to 12MP resolution
	Two-way Audio	1-ch, RCA (2.0 Vp-p, 1 KΩ)
Network	Incoming bandwidth	320 Mbps
	Outgoing bandwidth	256 Mbps, or 200 Mbps (when RAID is enabled)
	Remote connection	128
Video/ Audio Output	Recording resolution	12MP / 8MP / 6MP / 5MP / 4MP / 3MP / 1080p / UXGA / 720p / VGA / 4CIF / DCIF / 2CIF / CIF / QCIF
	CVBS output (Optional)	1-ch, BNC (1.0Vp-p, 75Ω), resolution: PAL: 704x576, NTSC: 704x480
	VGA1/HDMI1 output	HDMI1: 4K (3840x2160)/60Hz, 4K (3840x2160)/30Hz, 2K (2560x1440)/60Hz, 1920x1080p/60Hz, 1600x1200/60Hz, 1280x1024/60Hz, 1280x720/60Hz, 1024x768/60Hz
		VGA1: 2K (2560x1440)/60Hz, 1920x1080p/60Hz, 1600x1200/60Hz, 1280x1024/60Hz, 1280x720/60Hz, 1024x768/60Hz
	VGA2/HDMI2 output	1920x1080p/60Hz, 1280x1024/60Hz, 1280x720/60Hz, 1024x768/60Hz
	Audio Output	2-ch, RCA (2.0 Vp-p, 1 KΩ)
	Decoding	Decoding format
Live view / Playback		12MP / 8MP / 6MP / 5MP / 4MP / 3MP / 1080p / UXGA / 720P / VGA / 4CIF / DCIF / 2CIF / CIF / QCIF
Synchronous playback		16-CH
Capacity		4-ch @ 4K or 16-ch @ 1080p
Network Management	Network protocols	TCP/IP, DHCP, HIK Cloud P2P, DNS, DDNS, NTP, SADP, SMTP, NFS, iSCSI, UPnP™, HTTPS, RTP, UDP/IP, HTTP, FTP, SNMP
	Hard Disk	SATA: 8 SATA interfaces eSATA: 1 eSATA interface Capacity: Up to 10TB capacity for each HDD
Disk Array	Array type	RAID0, RAID1, RAID5, RAID6, RAID10
	Number of arrays	4
External Interface	Network Interface	2, RJ-45 10/100/1000 Mbps self-adaptive Ethernet Interface
	Serial Interface	RS-232; RS-485; Keyboard
	USB Interface	Front panel: 2 x USB 2.0; Rear panel: 1 x USB 3.0
	Alarm In/out	16/4
General	Power Supply	100 to 240 VAC, 50 to 60 Hz
	Max. Power	200 W
	Consumption	≤ 30 W
	Working Temperature	-10° to +55° C (14 to 131° F)
	Working Humidity	10 to 90%
	Chassis	19-inch rack-mounted 2U chassis
	Dimensions (WxDxH)	445 x 470 X 90 mm (17.5" x 18.5" x 3.5")
Weight (w/o hard disk)	≤ 10 kg (22 lb)	

THK-NR710-64

64CH NVR with 8 hard drive bay



KEY FEATURES

- Dual-OS design to ensure high reliability of system running
- Up to 64-ch 12MP IP cameras can be connected
- H.264+ compression effectively reduces the storage space and costs by up to 50%
- Full channel recording at up to 12MP resolution
- HDMI1 Video output at up to 4K (3840x2160) resolution
- Up to 8 SATA interfaces and 1 eSATA interface connectable for recording and backup
- POS triggered recording and alarm
- Host and user authentication (up to 20 users)

PHYSICAL INTERFACES

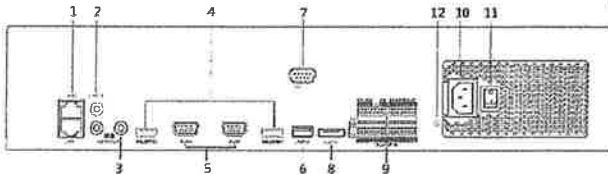

Index	Description	Index	Description
1	LAN1/LAN2 Interface	7	RS-232 Interface
2	LINE IN	8	eSATA interface
3	AUDIO OUT	9	Alarm In / Alarm Out
4	HDMI1 / HDMI2 interface	10	100 to 240 VAC power supply
5	VGA1 / VGA2 interface	11	Power Switch
6	USB 3.0 Interface	12	GND

CMS (Remote Viewing Apps) — IVMS 4200 (PC / MAC)

Mobile App — Guarding Expert (ANDROID / iOS)

THK-NR710-64		
Video/ Audio Input	IP Video Input	64-ch Up to 12MP resolution
	Two-way Audio	1-ch, RCA (2.0 Vp-p, 1 KΩ)
Network	Incoming bandwidth	320 Mbps
	Outgoing bandwidth	256 Mbps, or 200 Mbps (when RAID is enabled)
	Remote connection	128
Video/ Audio Output	Recording resolution	12MP / 8MP / 6MP / 5MP / 4MP / 3MP / 1080p / UXGA / 720p / VGA / 4CIF / DCIF / 2CIF / CIF / QCIF
	CVBS output (Optional)	1-ch, BNC (1.0Vp-p, 75Ω), resolution: PAL: 704x576, NTSC: 704x480
	VGA1/HDMI output	HDMI1: 4K (3840x2160)/60Hz, 4K (3840x2160)/30Hz, 2K (2560x1440)/60Hz, 1920x1080p/60Hz, 1600x1200/60Hz, 1280x1024/60Hz, 1280x720/60Hz, 1024x768/60Hz
	VGA2/HDMI2 output	1920x1080p/60Hz, 1280x1024/60Hz, 1280x720/60Hz, 1024x768/60Hz
	Audio Output	2-ch, RCA (2.0 Vp-p, 1 KΩ)
	Decoding	Decoding format
Live view / Playback		12MP / 8MP / 6MP / 5MP / 4MP / 3MP / 1080p / UXGA / 720P / VGA / 4CIF / DCIF / 2CIF / CIF / QCIF
Synchronous playback		16-CH
Capacity		4-ch @ 4K or 16-ch @ 1080p
Network Management	Network protocols	TCP/IP, DHCP, HIK Cloud P2P, DNS, DDNS, NTP, SADP, SMTP, NFS, ISCSI, UPnP™, HTTPS, RTP, UDP/IP, HTTP, FTP, SNMP
	Hard Disk	SATA: 8 SATA Interfaces eSATA: 1 eSATA Interface Capacity: Up to 10TB capacity for each HDD
Disk Array	Array type	RAID0, RAID1, RAID5, RAID6, RAID10
	Number of arrays	4
External Interface	Network Interface	2, RJ-45 10/100/1000 Mbps self-adaptive Ethernet interface
	Serial Interface	RS-232; RS-485; Keyboard
	USB Interface	Front panel: 2 x USB 2.0; Rear panel: 1 x USB 3.0
	Alarm In/out	16/4
General	Power Supply	100 to 240 VAC, 50 to 60 Hz
	Max. Power	200 W
	Consumption	≤ 30 W
	Working Temperature	-10° to +55° C (14 to 131° F)
	Working Humidity	10 to 90%
	Chassis	19-inch rack-mounted 2U chassis
	Dimensions (WxDxH)	445 x 470 X 90 mm (17.5" x 18.5" x 3.5")
Weight (w/o hard disk)	≤ 10 kg (22 lb)	

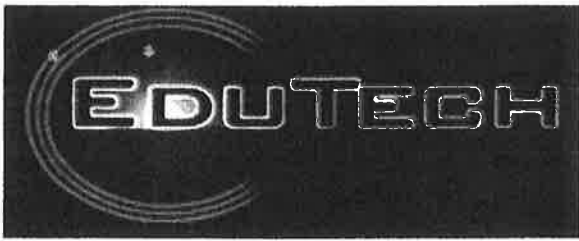

1150 Henry Street, Suite 4
 Dyersburg, TN 38024
 Phone: 800-324-1105
 Cell: 731-694-1092
 Fax: 731-285-0887
 don@edutech-tn.com

School Security Camera Systems - Hickman County Schools

Bid Form and Specifications/Scope of Work

The following Bid Form and Specifications/Scope of Work are to be used to submit bids by school.

Complete Pricing on this FORM and return with BID:

Camera Types: (cost should include any related licensing)
 (All cameras must be network capable)

Option 2: Axis Cameras

Camera Type	Price	Licensing
Single HD Dome Camera:	Axis M3065V \$286.00	Axis ACS Core Lic. \$80.00
Multi-position HD Camera: (minimum of 4 views)	Axis P3737-PLE4 \$1,345.00	Axis ACS Core Lic. \$80.00
HD PTZ Camera:	Axis M5525-E PTZ \$750.00	Axis ACS Core Lic. \$80.00
HD Bullet:	Axis M2025LE \$326.00	Axis ACS Core Lic. \$80.00
POE Mini Switch	4 Port POE \$65.00	N/A
	8 Port POE \$125.00	N/A
	24 Port POE \$425.00	N/A
Cat. 6 Network Drop (Riser)	\$150.00	N/A

Installation and all related materials

School	Installation Cost (including all related materials)	Other related Cost (please provide specifics on a separate sheet)
East Hickman High School	\$95.00 Per Camera	N/A
Hickman County High School	\$95.00 Per Camera	N/A
Option 1 Bid is for installation Axis Cameras and Licenses on existing Axis Camera Stations. Does not include any additional VMS Software		

AXIS M3065-V Network Camera HDTV 1080p fixed mini dome with HDMI

AXIS M3065-V features day/night functionality and WDR for sharp video even when there's both dark and light areas in the scene. This ultra-compact camera comes factory-focused, can easily be leveled and directed in any direction, plus offers HDMI support enabling streaming to a public view monitor. It supports intelligent analytics and thanks to the memory card slot, you can optionally record at the edge. Furthermore, Zipstream with support for H.264 and H.265 reduces bandwidth and storage requirements. The camera is made with 52% recycled plastics and is PVC/BFR/CFR free. And, its impact- and dust-resistant casing simply snaps on without visible screws.

- HDTV 1080p video quality
- WDR and day/night functionality
- Zipstream supporting H.264 and H.265
- HDMI output for streaming to a monitor
- Environmentally friendly

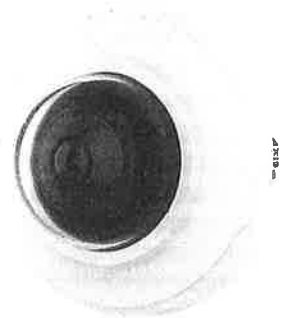

AXIS M3065-V Network Camera

Camera	
Image sensor	1/2.9" progressive scan RGB CMOS
Lens	3.1 mm, F2.0 Horizontal field of view: 102° Vertical field of view: 55° Fixed iris, IR corrected
Day and night	Automatically removable infrared-cut filter
Light sensitivity	Color: 0.2 lux at 50 IRE, F2.0 B/W: 0.04 lux at 50 IRE, F2.0
Shutter time	1/32500 s to 1/5 s
Camera angle adjustment	Pan: ±175° Tilt: ±80° Rotation: ±175° Can be directed in any direction and see the wall/ceiling
Video	
Video compression	H.264 (MPEG-4 Part 10/AVC) Baseline, Main and High Profiles H.265 (MPEG-H Part 2/HEVC) Main Profile Motion JPEG
Resolution	1920x1080 (1080p) to 320x240
Frame rate	25/30 fps with power line frequency 50/60 Hz
Video streaming	Multiple, individually configurable streams in H.264, H.265 and Motion JPEG Axis Zipstream technology in H.264 and H.265 Controllable frame rate and bandwidth VBR/MBR H.264/H.265 HDMI
Multi-view streaming	2 individually cropped out view areas
Pan/Tilt/Zoom	Digital PTZ
HDMI output	HDMI 1080p (16:9) @25/30 fps (50/60 Hz) HDMI 720p (16:9) @50/60 fps (50/60 Hz)
Image settings	Compression, color saturation, brightness, sharpness, contrast, white balance, day/night threshold, exposure control (including automatic gain control), WDR up to 115 dB depending on scene, fine tuning of low-light behavior, text and image overlay, privacy masks, mirroring, rotation: 0°, 90°, 180°, 270°, including Corridor Format
Audio	
Audio input/output	Two-way audio connectivity via the optional AXIS T61 Audio and I/O Interfaces with portcast technology
Network	
Security	Password protection, IP address filtering, HTTPS ^a encryption, IEEE 802.1x (EAP-TLS) ^a network access control, digest authentication, user access log, centralized certificate management, brute force delay protection, signed firmware
Supported protocols	IPv4, IPv6 USGv6, HTTP, HTTPS ^a , SSL/TLS ^a , QoS Layer 3 DiffServ, FTP, SFTP, CIFS/SMB, SMTP, Bonjour, UPnP ^b , SNMP v1/v2c/v3 (MIB-II), DNS, DynDNS, NTP, RTSP, RTP, SRTP, TCP, UDP, IGMP, RTCP, ICMP, DHCP, ARP, SOCKS, SSH, SIP, LLDP
System integration	
Application Programming Interface	Open API for software integration, including VAPIX [®] and AXIS Camera Application Platform; specifications at axis.com AXIS Video Hosting System (AVHS) with One-Click Connection ONVIF [®] Profile G, ONVIF [®] Profile S, and ONVIF [®] Profile T, specification at onvif.org Support for Session Initiation Protocol (SIP) for integration with Voice over IP (VoIP) systems, peer to peer or integrated with SIP/PBX.
Analytics	Included AXIS Video Motion Detection, active tampering alarm Supported Autotracking, AXIS Fence Guard, AXIS Motion Guard, AXIS Loitering Guard, AXIS People Counter, AXIS Queue Monitor, AXIS Occupancy Estimator, AXIS Direction Detector, AXIS Tailgating Detector, AXIS Random Selector Support for AXIS Camera Application Platform enabling installation of third-party applications, see axis.com/acap
Event triggers	Analytics, edge storage events Virtual inputs through API
Event actions	Record video: SD card and network share Upload of images or video clips: FTP, SFTP, HTTP, HTTPS, network share, and email Pre- and post-alarm video or image buffering for recording or upload Notification: email, HTTP, HTTPS, TCP, and SNMP trap Overlay text
Data streaming	Event data
Built-in installation aids	Pixel counter
General	
Casing	IP42 water- and dust-resistant (to comply with IP42, follow Installation Guide), IK08 impact-resistant, polycarbonate/ABS casing Encapsulated electronics Color: white NCS S 1002-B For repainting instructions, contact your Axis partner.
Sustainability	52% recycled plastics, PVC-free, BFR/CFR free
Memory	512 MB RAM, 512 MB Flash
Power	Power over Ethernet (PoE) IEEE 802.3af/802.3at Type 1 Class 1 Typical 2.2 W, max 2.5 W
Connectors	RJ45 10BASE-T/100BASE-TX PoE ^b HDMI Type D ^b Audio and I/O connectivity via optional AXIS T61 Audio and I/O Interfaces with portcast technology
Storage	Support for microSD/microSDHC/microSDXC card and encryption Recording to network-attached storage (NAS) For SD card and NAS recommendations see axis.com
Operating conditions	0 °C to 45 °C (32 °F to 113 °F) Humidity 15–85% RH (non-condensing)
Storage conditions	-40 °C to 65 °C (-40 °F to 149 °F) Humidity 5–95% RH (non-condensing)
Approvals	EMC ICES-3(A)/NMB-3(A), EN 55024, EN 55035, EN 61000-6-1, EN 61000-6-2, FCC Part 15 Subpart B Class A, ICES-003 Class A, VCCI Class A, ICES-3(A)/NMB-3(A) Safety IEC/EN/UL 62368-1 Environment EN 60068-2-1, EN 60068-2-2, EN 60068-2-6, EN 60068-2-14, EN 60068-2-27, EN 60068-2-78, IEC/EN 60529 IP42, IEC/EN 62262 Class IK08, RoHS, WEEE Network NIST SP500-267
Dimensions	Height: 56 mm (2.2 in) ø 101 mm (4.0 in)
Weight	150 g (0.33 lb)
Included accessories	Installation Guide, Windows [®] decoder 1-user license
Optional accessories	AXIS T94B02D Pendant kit AXIS TM3201 Recessed mount AXIS TM3101 Pendant Wall Mount AXIS T94B01P Conduit back box AXIS T94B02M J-Box/Gang box plate AXIS T6101 Audio and I/O Interface AXIS T6112 Audio and I/O Interface Black casing Smoked dome Axis Mounts AXIS Surveillance microSDXC™ Card For more accessories see axis.com
Video management software	AXIS Companion, AXIS Camera Station, video management software from Axis Application Development Partners available at axis.com/vms
Languages	English, German, French, Spanish, Italian, Russian, Simplified Chinese, Japanese, Korean, Portuguese, Traditional Chinese

Warranty Axis 3-year warranty and AXIS Extended Warranty option, see axis.com/warranty

a. *This product includes software developed by the OpenSSL Project for use in the OpenSSL Toolkit. (openssl.org), and cryptographic software written by Eric Young (eay@cryptsoft.com).*

b. *Make sure that the cable has a slim connector plug*

Environmental responsibility:
axis.com/environmental-responsibility

AXIS P3717-PLE Network Camera

8 MP multidirectional camera with IR for 360° coverage

AXIS P3717-PLE Network Camera is a compact 8-megapixel camera with four varifocal lenses enabling overview and detailed surveillance. With one IP address and one network cable, the four-camera-in-one unit provides a flexible, cost-effective solution for multidirectional surveillance. 360° IR illumination, Forensic WDR and Lightfinder technology provides excellent video quality in any light conditions. Each camera head can be individually positioned (pan, tilt, roll and twist) along a circular track. Remote zoom and focus makes it easy to install and the clear cover, with no sharp edges, ensures undistorted views in all directions. The camera comes with an integrated weathershield.

- 8 MP, 360° multidirectional camera, one IP address
- 360° IR illumination and remote zoom and focus
- Axis Lightfinder and Forensic WDR
- Flexible positioning of four varifocal camera heads
- Axis Zipstream for reduced bandwidth and storage needs

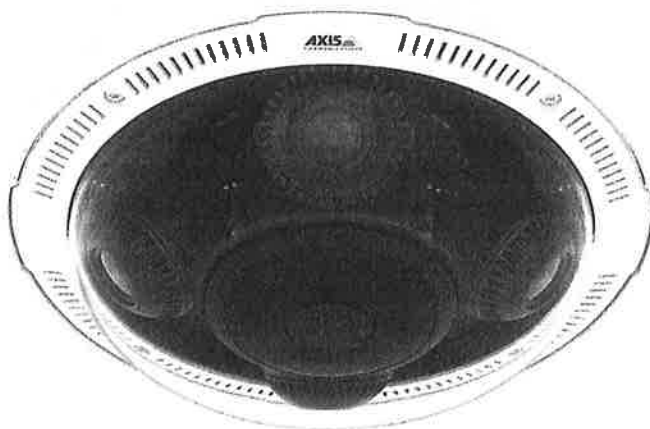

AXIS P3717-PLE Network Camera

Camera		Data streaming	Event data
Image sensor	4 x 1/2.8" progressive scan RGB CMOS	Built-in installation aids	Pixel counter, focus assistant, remote focus, remote zoom
Lens	Varifocal, 3–6 mm, F1.8–2.6 4x1080p capture mode: Horizontal field of view: 96°–49° Vertical field of view: 53°–27° Diagonal field of view: 113°–55° Motorized focus, motorized zoom	General	
Day and night	Automatically removable infrared-cut filter	Casing	IP66-, IP67-, NEMA 4X-rated, IK09 impact-resistant, aluminium and plastic casing with polycarbonate hard-coated dome, sunshield (PC/ASA) Color: white NCS S 1002-B For repainting instructions of casing and impact on warranty, contact your Axis partner.
Minimum illumination	Color: 0.17 lux at 50 IRE F1.8 B/W: 0.04 lux at 50 IRE F1.8, 0 lux with IR illumination on	Mounting	Mounting bracket with junction box holes (double gang box, single gang box, 4" octagon junction box and 4" square junction box) 1/2" (M20) conduit side entry 3/4" (M25) conduit adapter included
Shutter time	1/32500 s to 2 s with 50 Hz 1/32500 s to 2 s with 60 Hz	Sustainability	PVC free
Camera angle adjustment	Pan ±90°, tilt +25 to +95°, rotation –5 to +95°, twist ±20°	Memory	1024 MB RAM, 512 MB Flash
Video		Power	Power over Ethernet (PoE) IEEE 802.3at Type 2 Class 4 IR illumination on: class 4, typical 11.1 W, max 17.0 W IR illumination off: class 3, typical 8.6 W, max 11.0 W
Video compression	H.264 (MPEG-4 Part 10/AVC) Baseline, Main and High Profiles Motion JPEG	Connectors	Shielded RJ45 10BASE-T/100BASE-TX PoE Audio and I/O connectivity via AXIS T61 Audio and I/O Interfaces with portcast technology
Resolution	4 x 1920x1080 (4 x HDTV 1080p) to 160x90	IR illumination	Four individually controllable IR with power-efficient, long-life 850 nm IR LEDs Range of reach 15 m (50 ft) or more depending on the scene
Frame rate	Up to 25/30 fps (50/60 Hz)	Storage	Support for microSD/microSDHC/microSDXC card Dual SD cards Support for SD card encryption Support for recording to network-attached storage (NAS) For SD card and NAS recommendations see axis.com
Video streaming	Multiple, individually configurable streams in H.264 and Motion JPEG Axis Zipstream technology in H.264 Controllable frame rate and bandwidth VBR/ABR/MBR H.264	Operating conditions	–30 °C to 50 °C (–22 °F to 112 °F) Humidity 10–100% RH (condensing)
Image settings	Saturation, contrast, brightness, sharpness, Forensic WDR, white balance, exposure control, exposure zone, fine tuning of behavior at low light, rotation: 0°, 90°, 180°, 270° including Corridor Format, dynamic text and image overlay, Polygon privacy mask, compression	Storage conditions	–40 °C to 65 °C (–40 °F to 149 °F)
Audio		Approvals	EMC EN 55032 Class A, EN 50121–4, IEC 62236–4, EN 61000–3–2, EN 61000–3–3, EN 55024, EN 61000–6–1, EN 61000–6–2, FCC Part 15 Subpart B Class A, ICES-003 Class A, VCCI Class A, RCM AS/NZS CISPR 32 Class A, KC KN32 Class A, KC KN35 Safety IEC/EN/UL 62368–1, IEC/EN/UL 60950–22, IEC 62471, IS 13252 Environment IEC 60068–2–1, IEC 60068–2–2, IEC 60068–2–6, IEC 60068–2–14, IEC 60068–2–27, IEC 60068–2–78, IEC/EN 60529 IP66/67, IEC/EN 62262 IK09, NEMA 250 Type 4X, NEMA TS 2–2016
Audio input/output	Two-way audio connectivity via AXIS T61 Audio and I/O Interfaces with portcast technology A 30 W midspan or higher between AXIS T61 Audio and I/O Interfaces and AXIS P3717-PLE is required.	Dimensions	Height: 91.5 mm (3.6 in) ø 255 mm (10.04 in)
Network		Weight	2.0 kg (4.4 lb)
IP address	One IP address for all channels	Included accessories	RJ45 mounting tool, screw bit T20, Installation guide, Windows® decoder 1-user license
Security	Password protection, IP address filtering, HTTPS ^a encryption, IEEE 802.1X (EAP-TLS) ^a network access control, digest authentication, user access log, centralized certificate management, brute force delay protection, signed firmware, secure boot	Optional accessories	AXIS T94N01D Pendant Kit, Axis mounts and cabinets For more accessories, see axis.com
Supported protocols	IPv4/v6, HTTP, HTTPS ^a , SSL/TLS ^a , QoS Layer 3 DiffServ, FTP, CIFS/SMB, SMTP, Bonjour, UPnP TM , SNMP v1/v2c/v3 (MIB-II), DNS, DynDNS, NTP, RTSP, RTP, SFTP, TCP, UDP, IGMP, RTCP, ICMP, DHCP, ARP, SOCKS, SSH, LLDP	Video management software	AXIS Companion, AXIS Camera Station, video management software from Axis' Application Development Partners available at axis.com/vms
System integration		Languages	English, Simplified Chinese, Traditional Chinese, French, German, Italian, Japanese, Korean, Polish, Portuguese, Russian, Spanish
Application Programming Interface	Open API for software integration, including VAPIX [®] and AXIS Camera Application Platform; specifications at axis.com AXIS Video Hosting System (AVHS) with One-Click Connection ONVIF [®] Profile G and ONVIF [®] Profile S, specification at onvif.org	Warranty	Axis 3-year warranty, see axis.com/warranty
Analytics	Included AXIS Video Motion Detection, active tampering alarm Supported AXIS Guard Suite including AXIS Motion Guard, AXIS Fence Guard, and AXIS Loitering Guard Support for AXIS Camera Application Platform enabling installation of third-party applications, see axis.com/acup	Footnote	a. This product includes software developed by the OpenSSL Project for use in the OpenSSL Toolkit. (openssl.org), and cryptographic software written by Eric Young (ey@cryptsoft.com).
Event triggers	Detectors, hardware, input signal, storage, system, time, analytics, edge storage events	Environmental responsibility:	axis.com/environmental-responsibility
Event actions	Day/night vision mode, overlay text, record video, send images, send notification, send SNMP trap, send video clip, status LED File upload: FTP, HTTP, HTTPS, network share, SFTP and email Notification: email, HTTP, HTTPS, TCP and SNMP trap		

AXIS M5525-E PTZ Network Camera

Indoor and outdoor PTZ with 10x zoom

AXIS M5525-E PTZ Network Camera is a compact pan-tilt-zoom camera with HDTV 1080p resolution, 10x optical zoom, and autofocus, enabling great video quality in both overview and detail. Day/night functionality and WDR – Forensic Capture ensures maintained image quality in low or mixed light, and scene profiles are included for automatic optimization. AXIS M5525-E is compatible with any Axis PTZ mount for outdoor installation, but can also be surface-mounted indoors. Protected against dust, rain, snow, and corrosion, the camera operates in temperatures from -20 °C to 50 °C (-4 °F to 122 °F). The microSD card slot enables local video storage.

- > HDTV 1080p with 10x optical zoom
- > Continuous 360° for uninterrupted pan
- > WDR – Forensic Capture
- > Axis Zipstream technology
- > I/O ports and two-way audio



AXIS M5525-E PTZ Network Camera

Camera		Time: recurrence, use schedule
Image sensor	1/2.8" progressive scan CMOS	
Lens	4.7–47 mm, F1.6–3.0 Horizontal field of view: 61.8°–6.7° Vertical field of view: 37.2°–3.8° Autofocus, auto-iris	Event actions Record video: SD card and network share Upload of images or video clips: FTP, SFTP, HTTP, HTTPS, network share, and email Pre- and post-alarm video or image buffering for recording or upload Notification: email, HTTP, HTTPS, TCP, and SNMP trap PTZ: PTZ preset, start/stop guard tour Overlay text, play audio clip, external output activation, WDR mode
Day and night	Automatically removable infrared-cut filter	Data streaming Event data
Minimum illumination	Color: 0.45 lux at 30 IRE F1.6 B/W: 0.01 lux at 30 IRE F1.6 Color: 0.55 lux at 50 IRE F1.6 B/W: 0.01 lux at 50 IRE F1.6	Built-in installation aids Pixel counter
Shutter time	1/66500 s to 2 s	General
Pan/Tilt/Zoom	Pan: 360° endless, 1.8°–150°/s Tilt: 90°, 1.8°–150°/s 10x optical zoom, 12x digital zoom, total 120x zoom Nadir flip, 100 preset positions, limited guard tour, control queue, on-screen directional indicator	Casing IP66-, NEMA 4X- and IK09-rated Repaintable plastic casing, polycarbonate (PC) dome
Video		Sustainability PVC free
Video compression	H.264 (MPEG-4 Part 10/AVC) Baseline, Main and High Profiles Motion JPEG	Memory 512 MB RAM, 256 MB Flash
Resolution	1920x1080 to 320x180	Power Power over Ethernet (PoE) IEEE 802.3af/802.3at Type 1 Class 3 Typical 6.6 W, max 12.95 W 20–28 V DC, typical 6.3 W, max 13 W (PoE midspan and power supply not included)
Frame rate	Up to 25/30 fps with power line frequency 50/60 Hz	Connectors RJ45 10BASE-T/100BASE-TX PoE DC input terminal block I/O: 6-pin terminal block with push-in spring connection for four configurable inputs/outputs Audio: mic/line in, line out terminal block with push-in spring connection
Video streaming	Multiple, individually configurable streams in H.264 and Motion JPEG Axis Zipstream technology in H.264 Controllable frame rate and bandwidth VBR/MBR H.264	Storage Support for microSD/SDHC/SDXC card (not included) Support for SD card encryption Support for recording to network-attached storage (NAS) For SD card and NAS recommendations see axis.com
Image settings	Saturation, brightness, sharpness, WDR – forensic capture, white balance, exposure mode, exposure zones, compression, text and image overlay, 20 individual 3D privacy masks, contrast, scene profiles, image freeze on PTZ, local contrast, max shutter, max gain, noise/motion priority, aperture lock, exposure level, rotation: 0°, 180°	Operating conditions –20 °C to 50 °C (–4 °F to 122 °F) Humidity 15–100% RH (condensing)
Audio		Storage conditions –40 °C to 65 °C (–40 °F to 149 °F)
Audio streaming	Two-way, full duplex	Approvals EMC EN 55032 Class A, EN 61000-3-2, EN 61000-3-3, EN 55024, EN 61000-6-1, EN 61000-6-2, FCC Part 15 Subpart B Class A, ICES-003 Class A, VCCI Class A, RCM AS/NZS CISPR 32 Class A, KC KN32 Class A, KN35 Safety IEC/EN/UL 62368-1, IEC/EN/UL 60950-22, IS 13252 Environment IEC 60068-2-27, IEC 60068-2-6, IEC/EN 60529 IP66, IEC/EN 62262 IK09 Network NIST SP500-267
Audio compression	AAC-LC 8/16/32 kHz, G.711 PCM 8 kHz, G.726 ADPCM 8 kHz Configurable bit rate	Dimensions Height: 132 mm (5.2 in), ø 165 mm (6.5 in)
Audio input/output	External microphone input or line input, line output	Weight 1.1 kg (2.4 lb) Recessed mount (plenum rated): 1.0 kg (2.2 lb)
Network		Included accessories Conduit adapter 3/4", smoked dome, adapter bayonette Installation Guide, Windows® decoder 1-user license
Security	Password protection, IP address filtering, HTTPS ³ encryption, IEEE 802.1X ³ network access control, Digest authentication, User access log, Centralized Certificate Management, Brute force delay protection	Optional accessories AXIS T91 Mounting Accessories, AXIS T94P01L Recessed Mount Kit
Supported protocols	IPv4, IPv6, USGv6, HTTP, HTTPS ³ , SSL/TLS ³ , QoS Layer 3 DiffServ, FTP, SFTP, CIFS/SMB, SMTP, Bonjour, UPnP TM , SNMP v1/v2c/v3(MIB-II), DNS, DynDNS, NTP, RTP, TCP, UDP, IGMP, RTCP, ICMP, DHCP, ARP, SOCKS, SSH, LLDP	Video management software AXIS Companion, AXIS Camera Station, video management software from Axis' Application Development Partners available at axis.com/vms
System integration		Languages English, German, French, Spanish, Italian, Russian, Simplified Chinese, Japanese, Korean, Portuguese, Traditional Chinese
Application Programming Interface	Open API for software integration, including VAPIX [®] and AXIS Camera Application Platform; specifications at axis.com AXIS Guardian with One-Click Connection ONVIF [®] Profile S and ONVIF [®] Profile G, specification at onvif.org	Warranty Axis 3-year warranty and AXIS Extended Warranty option, see axis.com/warranty
Analytics	Included AXIS Video Motion Detection, audio detection, advanced gatekeeper Supported AXIS Cross Line Detection, AXIS Guard Suite including AXIS Fence Guard, AXIS Motion Guard and AXIS Loitering Guard Support for AXIS Camera Application Platform enabling installation of third-party applications, see axis.com/acap	
Event triggers	Analytics, edge storage events Detectors: day/night mode, live stream accessed, audio detection Hardware: network, temperature Input Signal: digital input port, manual trigger, virtual inputs PTZ: error, moving, preset reached, ready Storage: disruption, recording System: system ready	

a. This product includes software developed by the OpenSSL Project for use in the OpenSSL Toolkit. (www.openssl.org), and cryptographic software written by Eric Young (eay@cryptsoft.com).

Environmental responsibility:

axis.com/environmental-responsibility

AXIS M2025-LE Network Camera

Affordable and outdoor-ready camera with built-in IR

AXIS M2025-LE is a small, bullet-style camera delivering high-quality images in HDTV resolution. It has built-in IR illumination that enables surveillance up to 15 m even at nighttime. The outdoor-ready camera is resistant to rough weather and the integrated sunshield protects against sun and rain. With a 115° field of view, a single camera gives full surveillance at low cost, and Axis Corridor Format provides efficient monitoring of corridors and shopping aisles. WDR – Forensic Capture increases forensic usability by highlighting details in both dark and well-lit areas. The spacious back box enables secure cable management and easy installation.

- > Outdoor-ready, IP66, and NEMA 4X rated
- > HDTV 1080p
- > Built-in IR illumination
- > 115° field of view
- > Zigstream

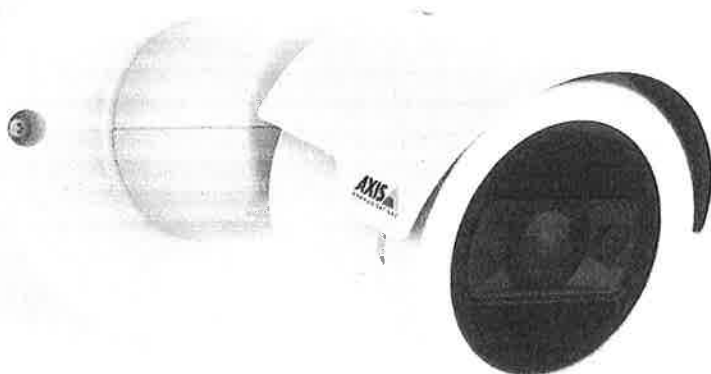

AXIS M2025-LE Network Camera

Models	AXIS M2025-LE AXIS M2025-LE Black	Data streaming	Event data
Camera		Built-in installation aids	Pixel counter
Image sensor	1/2.8" progressive scan RGB CMOS	General	
Lens	M12 mount, Fixed iris, Fixed focus 2.8 mm, F2.0 Horizontal field of view: 115° Vertical field of view: 64°	Casing	IP66-, NEMA 250 Type 4X-, and IK08-rated, polymer casing Encapsulated electronics, captive screws (Torx® 10) M2025-LE: Color: White NCS S 1002-B M2025-LE Black: Color: Black NCS S 9000-N
Day and night	Automatically removable infrared-cut filter	Sustainability	PVC free
Minimum illumination	Color: 0.2 lux at 50 IRE, F2.0 B/W: 0.04 lux at 50 IRE, F2.0 0 lux with IR illumination on	Memory	512 MB RAM, 256 MB Flash
Shutter time	1/65000 s to 2 s	Power	Power over Ethernet (PoE) IEEE 802.3af/802.3at Type 1 Class 2 Typical 4.1 W, max 6.3 W
Video		Connectors	RJ45 10BASE-T/100BASE-TX PoE
Video compression	H.264 (MPEG-4 Part 10/AVC) Baseline, Main and High Profiles Motion JPEG	IR illumination	Power-efficient, long-life 850 nm IR LED. Range of reach up to 15 m (50 ft) depending on scene
Resolution	1920x1080 to 160x90	Storage	Support for microSD/microSDHC/microSDXC card Support for SD card encryption Support for recording to network-attached storage (NAS) For SD card and NAS recommendations see axis.com
Frame rate	Up to 25/30 fps with power line frequency 50/60 Hz	Operating conditions	-30 °C to 50 °C (-22 °F to 122 °F) Humidity 10–100% RH (condensing)
Video streaming	Multiple, individually configurable streams in H.264 and Motion JPEG Axis Zipstream technology in H.264 Controllable frame rate and bandwidth VBR/ABR/MBR H.264	Storage conditions	-40 °C to 65 °C (-40 °F to 149 °F) Humidity 5–95% RH (non-condensing)
Multi-view streaming	Up to 2 individually cropped out view areas in full frame rate	Approvals	EMC EN 55032 Class A, EN 55024, IEC 62471, EN 61000-6-1, EN 61000-6-2, FCC Part 15 Subpart B Class A, ICES-003 Class A, VCCI Class A, RCM AS/NZS CISPR 32 Class A, KCC KN32 Class A, KN35 Environment IEC 60068-2-1, IEC 60068-2-2, IEC 60068-2-78, IEC 60068-2-14, IEC 60068-2-6, IEC 60068-2-27, IEC/EN 62262 IK08, IEC/EN 60529 IP66, NEMA 250 Type 4X Safety IEC/EN/UL 62368-1, IS 13252 IEC/EN/UL 60950-22 Network NIST SP500-267
Image settings	Compression, color, brightness, sharpness, contrast, local contrast, white balance, exposure control, WDR – Forensic Capture: up to 115 dB depending on scene, rotation: 0°, 90°, 180°, 270° including Corridor Format, text and image overlay, privacy masks, mirroring of images	Dimensions	Height, straight: 174 mm (6.9 in) Height, angled: 118 mm (4.6 in) ø 101 mm (4.0 in)
Pan/Tilt/Zoom	Digital PTZ	Weight	0.5 kg (1.1 lb)
Network Security	Password protection, IP address filtering, HTTPS ^a encryption, IEEE 802.1x (EAP-TLS) ^a network access control, digest authentication, user access log, Centralized Certificate Management, brute force delay protection, signed firmware	Included accessories	Installation Guide, Windows® decoder 1-user license, Torx® L-key, Connector guard
Supported protocols	IPv4, IPv6 USGv6, HTTP, HTTPS ^a , SSL/TLS ^a , QoS Layer 3 DiffServ, FTP, SFTP, CIFS/SMB, SMTP, Bonjour, UPnP™, SNMP v1/v2c/v3 (MIB-II), DNS, DynDNS, NTP, RTP, RTSP, TCP, UDP, IGMP, RTCP, ICMP, DHCP, ARP, SOCKS, SSH, LLDP	Optional accessories	AXIS T94B03L Recessed Mount, AXIS T94B02D Pendant kit, AXIS T94B01P Conduit Back Box, AXIS T94B02M J-Box/Gang Box Plate, Axis mounts, AXIS Surveillance microSDXC™ Card AXIS T94 mounts for various installations For more accessories, see axis.com/vms
System integration		Video management software	AXIS Companion, AXIS Camera Station, video management software from Axis' Application Development Partners available at axis.com/vms
Application Programming Interface	Open API for software integration, including VAPIX® and AXIS Camera Application Platform; specifications at axis.com AXIS Video Hosting System (AVHS) with One-Click Connection ONVIF® Profile G, ONVIF® Profile S, and ONVIF® Profile T. Specifications at onvif.org	Languages	English, German, French, Spanish, Italian, Russian, Simplified Chinese, Japanese, Korean, Portuguese, Traditional Chinese
Analytics	Included AXIS Video Motion Detection, active tampering alarm Supported AXIS Digital Autotracking, AXIS Cross Line Detection, AXIS Fence Guard, AXIS Motion Guard, AXIS Loitering Guard Support for AXIS Camera Application Platform enabling installation of and third-party applications, see axis.com/acap	Warranty	Axis 3-year warranty and AXIS Extended Warranty option, see axis.com/warranty
Event triggers	Analytics, edge storage events		
Event actions	Record video: SD card and network share Upload of images or video clips: FTP, SFTP, HTTP, HTTPS, network share and email Pre- and post-alarm video or image buffering for recording or upload Notification: email, HTTP, HTTPS, TCP and SNMP trap Overlay text		

a. This product includes software developed by the OpenSSL Project for use in the OpenSSL Toolkit. (www.openssl.org), and cryptographic software written by Eric Young (coy@cryptsoft.com).

Environmental responsibility:
axis.com/environmental-responsibility

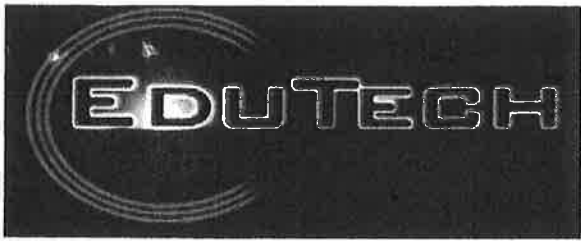

1150 Henry Street, Suite 4
Dyersburg, TN 38024
Phone: 800-324-1105
Cell: 731-694-1092
Fax: 731-285-0887
don@edutech-tn.com

Qualifications

EduTech Inc. is a C-Corporation, and started in business March 1, 1993.

EduTech Inc. Federal ID- 62-1523360

EduTech Inc. 1150 Henry St. Suite 4, Dyersburg, TN 38024

Jason Smith: Secretary-Treasurer/Owner

Cell Phone: 731-694-1194, Office Phone: 800-324-1105, Fax: 731-285-2386

EduTech Inc. has representatives located in Clarksville, Fairview, Dyersburg, and Jackson, Tennessee

We presently work throughout the state of Tennessee.

EduTech Inc. Contractor's License: **00041927 CE-D, CMC-A \$1,500,000.00**

EduTech Inc. Alarm Contractor's License: **00001151** Burglar/CCTV EduTech Inc.

Alarm Contractors Qualifying Agent License **00001152**

EduTech Inc. E-Rate Spin Number: **143011806**

EduTech has participated in E-Rate since 1998

EduTech is certified by the State of Tennessee as a Drug Free Workplace

EduTech has an ORI Number Registered with the State of Tennessee: **TN-VC00010**

EduTech Inc. is a Hubbell Authorized Dealer/Installer

EduTech Inc. is an Ortronics Authorized Dealer/Installer

EduTech Inc. is a Microsoft Academic Authorized Reseller

EduTech Inc. is a HP Authorized Partner/Installer

EduTech Inc. is a Faronics Authorized Partner/Installer

EduTech Inc. is an Aerohive Networks Authorized Partner/Installer

EduTech Inc. is a Netgear Platinum Partner

EduTech Inc. is an Equus Authorized Dealer/Installer

EduTech Inc. is a Video Insight Authorized Dealer/Installer

EduTech Inc. is a Hikvision Platinum Partner

EduTech Inc. is a Honeywell Authorized Dealer/Installer

EduTech Inc. is a Galaxy Control Systems Authorized Dealer/Installer

EduTech Inc. is an Avigilon Authorized Dealer/Installer

EduTech Inc. is a Truview Authorized Dealer/Installer

EduTech Inc. is presently bonded through White & Associates/First Citizens.

EduTech Inc. and employees have no conflict of interest with any school system in the state of Tennessee.

EduTech Inc. is presently insured with White & Associates/First Citizens. Our coverage exceeds limits in the areas listed. We presently carry a \$5,000,000 Commercial Umbrella policy that is in addition to the General Liability and Auto Liability

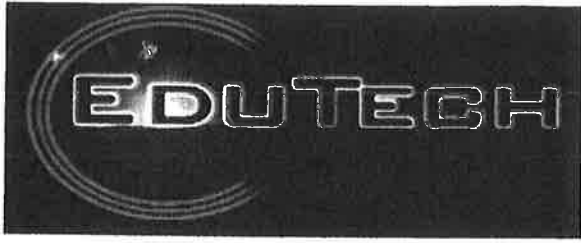

1150 Henry Street, Suite 4
Dyersburg, TN 38024
Phone: 800-324-1105
Cell: 731-694-1092
Fax: 731-285-0887
don@edutech-tn.com

Qualifications

EduTech Inc. has been in business since March 1, 1993

EduTech Inc. is a C-Corporation and our main office is located in Dyersburg, TN

EduTech Inc. has representatives located in Clarksville, Fairview, Dyersburg, and Jackson Tennessee areas.

EduTech Inc. is a family owned business and the owners take pride in developing long term relationships with its clients.

Organizational History- Kim Smith President, Don Smith Vice President, Tim Smith Vice President, Jason Smith Secretary/Treasurer (All officers have ownership in EduTech Inc.)

EduTech Inc. is a value added reseller and installer. We have never sub-contracted out any of our work unless a special license was required. We always have at least one of the owners overseeing each project and helping make sure the installation is done properly.

EduTech Inc. has about 80% of business in the areas of K-12 Education/Government Entities and 20% commercial and non-profit.

EduTech Inc. is also certified as a Tennessee Drug Free Workplace.

EduTech Inc. presently represents, sells and installs the following products:

Digital Surveillance Systems and Cabling-Honeywell, Bosch, Pelco, CNB, GeoVision, Divis, Axis, EXACQ, Truview, Hikvision, Video Insight, Advidia, Everfocus, and Avigilon

Burglar Alarm and Access Control Systems and Cabling-Honeywell, Securitron, Aiphone, CDVI, DSX, and Galaxy

Digital Telephone Systems and Cabling-NEC

Structured Cabling for Computer Networks and Telephone Systems- Hubbell, Ortronics, Panduit, Belden, General, Superior Essex, Berk-Tek, ICC, ComScope, Mohawk, Coleman, Honeywell, Genesis, Corning, HP Procurve, Netgear, Jbiquiti, and Aerohive Networks

Computer Hardware and Software-HP, Symantec, Microsoft, Acer, AOC, CyberPower, Faronics, Equus, and Asus

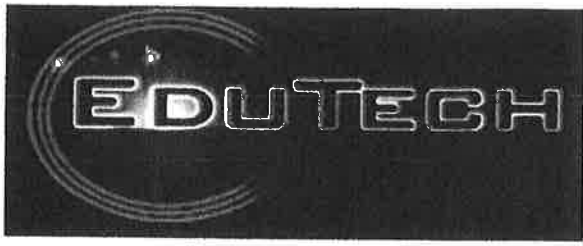

1150 Henry Street, Suite 4
Dyersburg, TN 38024
Phone: 800-324-1105
Cell: 731-694-1092
Fax: 731-285-0887
don@edutech-tn.com

Qualifications

Project Understanding:

EduTech Inc. has reviewed the abbreviated scope of work for this project. We feel that we understand the requirements. We represent several manufacturers that have products and equipment that will satisfy these requirements.

Project Approach:

EduTech Inc. has reviewed the detailed specifications and comprehensive building plans. We have reviewed the specific requirements that are located in the Request for Proposal. We have consulted with the various manufacturer's engineers and technical support personnel to determine what equipment is needed and the best way to lay out this project. We will consult with the owners about the project schedule and determine the best way to accomplish their goals.

Project Management

EduTech Inc. will always have at least one of the owners/officers of the corporation overseeing this project. The owner/officer that is overseeing this project will be on the jobsite when the work is being completed. We will do everything possible to complete the scope of work in an organized and timely manner with as little down time as possible at the school.

Project Staffing

EduTech Inc. has reviewed the detailed specifications and comprehensive building plans. We will consult with the owners about the time schedule required on this project. At that time, we will be able to determine what the staffing requirements will be at each location. One of the owners/officers will be overseeing this project will be on-site when the work is being completed.

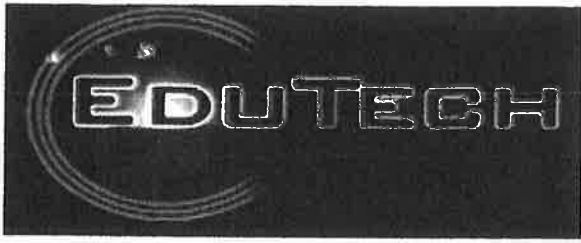

1150 Henry Street, Suite 4
Dyersburg, TN 38024
Phone: 800-324-1105
Cell: 731-694-1092
Fax: 731-285-0887
don@edutech-tn.com

Qualifications

Diversity Initiatives

EduTech Inc. is an equal opportunity employer. EduTech Inc. does not discriminate based on race, sex, or religion. EduTech Inc. is committed and always looking for ways to diversify our business relationships and workforce.

Organizational Charts

Kim Smith: President/Owner, Cell Phone: 731-694-1078

Employment: March 1 1993 to Present

Kim is an owner of EduTech and is based in the Clarksville area. He has over 25 years' experience in structured cabling, wireless network installations, video surveillance systems, access control systems, intercom systems, telephone systems, and burglar alarm systems. Kim is certified as a Certified Alarm Technician by the National Fire and Burglar Alarm Association.

Education- High School Graduate, College-2 years

Background Check and Finger Printing Completed by Alarm Contractors Board

Don Smith: Vice President/Owner, Cell Phone: 731-694-1092

Employment: March 1, 1993 to Present

Don is an owner of EduTech and is based in the Fairview area. He has over 25 years' experience in structured cabling, wireless network installations, video surveillance systems, access control systems, intercom systems, telephone systems, and burglar alarm systems. Don is certified as a Certified Alarm Technician by the National Fire and Burglar Alarm Association. Don is the Qualifying Agent for EduTech Inc.

Education- College- Austin Peay State University

Bachelor's Degree: Business Administration

Background Check and Finger Printing Completed by Alarm Contractors Board

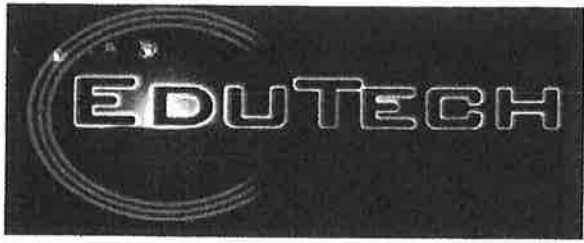

1150 Henry Street, Suite 4
Dyersburg, TN 38024
Phone: 800-324-1105
Cell: 731-694-1092
Fax: 731-285-0887
don@edutech-tn.com

Qualifications

Organizational Charts

Tim Smith: Vice President/Owner, Cell Phone: 731-694-0613
Employment: March 1, 1993 to Present

Tim is an owner of EduTech and is based in the Dyersburg area. He has over 25 years' experience in structured cabling, wireless network installations, video surveillance systems, access control systems, intercom systems, telephone systems, and burglar alarm systems. Tim is certified as a Certified Alarm Technician by the National Fire and Burglar Alarm Association.

Education- High School Graduate, College-2 years

Background Check and Finger Printing Completed by Alarm Contractors Board

Jason Smith: Secretary-Treasurer/Owner, Cell Phone: 731-694-1194
Employment: Jan 1, 2000 to Present

Jason is an owner of EduTech and is based in the Jackson area. He has over 18 years' experience in structured cabling, wireless network installations, video surveillance systems, access control systems, intercom systems, telephone systems, and burglar alarm systems. Jason is certified as a Certified Alarm Technician by the National Fire and Burglar Alarm Association.

Education- College- Murray State University

Bachelor Degree: Business-Marketing

Background Check and Finger Printing Completed by Alarm Contractors Board

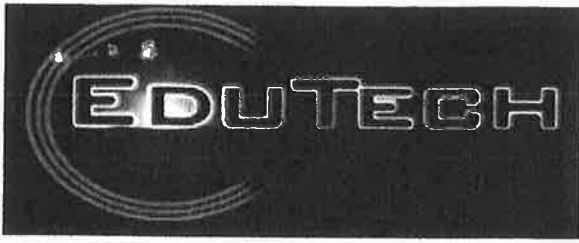

1150 Henry Street, Suite 4
Dyersburg, TN 38024
Phone: 800-324-1105
Cell: 731-694-1092
Fax: 731-285-0887
don@edutech-tn.com

Qualifications

Scheduling Capacity

The owner/officer that is overseeing the project is responsible for scheduling. He is accustomed to regularly scheduled meetings to report progress or address any concerns about the project. He will take the hands on approach, and he will work with customer to achieve a desirable schedule.

Quality Control

EduTech Inc. will make sure that an owner/officer is involved in every installation. This insures that the employees are meeting or exceeding our expectations on the quality of the work. We do not use sub-contractors unless a special license is required for a certain part of the project. If subcontractors need to be used, we will make sure that the owner/officer of EduTech is onsite when they are completing their work.

Safety Approach

EduTech Inc. has an excellent history regarding safety in the workplace. We have only had 3 workers compensation claims since we started EduTech Inc. in 1993. We are certified by the State of Tennessee as a Drug Free Workplace. We require that all new employees submit to drug test before employment, and random drug test are taken on existing employees. If employees are injured on the job, they are required to take a drug test as soon as possible following the injury. We make sure that all employees have been properly trained in the areas that they are working.

Drug Testing

EduTech Inc. is certified by the State of Tennessee as a Drug Free Workplace. We require that all new employees submit to drug test before employment, and random drug test are taken on existing employees. If employees are injured on the job, they are required to take a drug test as soon as possible following the injury.

****EduTech certifies in writing that we are not currently debarred, suspended, proposed for debarment, declared ineligible by any Federal Department or Government agency. EduTech certifies in writing that we have not been terminated from government contracts in the past three years.****

Completed By:
Don Smith
EduTech Inc.
Vice President
May 4, 2020

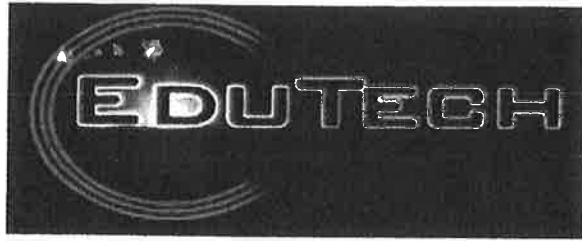

1150 Henry Street, Suite 4
Dyersburg, TN 38024
Phone: 800-324-1105
Cell: 731-694-1092
Fax: 731-285-0887
don@edutech-tn.com

EDUTECH INC. REFERENCE LIST

**LEWIS COUNTY SCHOOLS
JUSTIN HILDENBRANDT
JUSTIN.HILDENBRANDT@TENNK12.NET
931-796-3264
206 SOUTH COURT STREET
HOHENWALD, TN 38462**

**GIBSON COUNTY SPECIAL SCHOOL DISTRICT
JAMIE BARR
JAMIE@GCSSD.ORG
731-692-3803
130 TRENTON HIGHWAY
DYER, TN 38330**

**OBION COUNTY SCHOOLS
PHIL GRAHAM
PGRAHAM@OCBOE.COM
731-536-4226
802 CC GURIEN DRIVE
TROY, TN 38260**

**LAUDERDALE COUNTY SCHOOLS
DONNIE YORK
DYORK@MAIL.LCED.NET
731-635-2941
321 ARMORY STREET
RIPLEY, TN 38063**

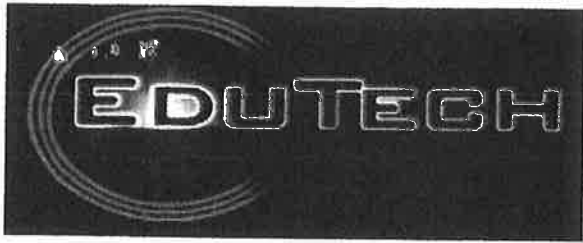

1150 Henry Street, Suite 4
Dyersburg, TN 38024
Phone: 800-324-1105
Cell: 731-694-1092
Fax: 731-285-0887
don@edutech-tn.com

EDUTECH INC. REFERENCE LIST

SEQUATCHIE COUNTY SCHOOLS

TRIPP LAYNE

TRIPP@SEQUATCHIE.K12.TN.US

423-949-3617

878 CORDELL DRIVE

DUNLAP, TN 37327

BELLS CITY SCHOOLS

DEBBIE OSWALT

DEBBIEOSWALT@BELLSCITYSCHOOL.ORG

731-693-2041

4547 HWY 88 SOUTH

BELLS, TN 38006

MOORE COUNTY SCHOOLS

MONICA HARDIN

MONICA.HARDIN@MOORECOUNTYSCHOOLS.NET

931-759-7303

241 MAIN STREET

LYNCHBURG, TN 37352

	EDUTECH	HOWARD	BGC	EDUTECH	BGC
Single Dome	\$286.00	\$205.00	\$295.00	\$611.00	\$558.00
4-Way	Axis M3065V \$1,345.00	Axis M3065V	Axis M3115	Axis M3065V	Axis M3115
PTZ	Axis P3717 \$750.00	Axis P3717	Axis P3717	Axis P3717	Axis P3717
HD Outdoor Bullet	Axis M5525-E \$326.00	Axis M5525-E	Axis M5525-E	Axis M5525-E	Axis M5525-E
License (per camera)	Axis M2025LE \$80.00	\$60.00	Axis P1435-LE \$78.00	\$651.00	\$812.00
Install (per camera)	\$95.00		\$185.00	Axis M2025LE	Axis P1435-LE
CAT 6 Drop (per camera)	\$150.00	\$31.00	\$0.00		
NVR Recorder		\$10,615			
Complete Install		\$21,350.00			
Complete Programming		\$2,465.00			

Hickman County Tennessee
 Central Cafeteria Fund 143
 Statement of Proposed Operations
 For the Fiscal Year Ending June 30, 2021

Account No	Description	Actual 2018-2019	Original Estimated 2019-2020	Amended Estimated 2019-2020	Estimated 2020-2021	Difference 2020-2021
<u>ESTIMATED REVENUES</u>						
43000	<u>CHARGES FOR CURRENT SERVICES</u>					
43500	<u>Education Charges</u>					
43521	Lunch Payments Children	0	0	0	240,000	240,000
43522	Lunch Payments Adults	64,285	65,000	65,000	65,000	0
43523	Income from Breakfast	4,389	4,500	4,500	65,000	60,500
43525	A la Carte Sales	150,922	145,000	145,000	244,100	99,100
	Total Charges for Current Services	219,596	214,500	214,500	614,100	399,600
44000	<u>OTHER LOCAL REVENUES</u>					
44100	<u>Recurring Items</u>					
44110	Investment Income	180	200	200	200	0
44500	<u>Non-Recurring Items</u>					
44170	Miscellaneous Refunds	0	0	0		
44530	Sale of Equipment	0	0	0		0
	Total Other Local Revenues	180	200	200	200	0
47000	<u>FEDERAL GOVERNMENT</u>					
47100	<u>Federal Through State</u>					
47111	USDA School Lunch Program	1,215,150	1,305,000	1,305,000	1,065,000	(240,000)
47112	USDA-Commodities	101,623	0	0		0
47113	Breakfast	553,524	580,000	580,000	480,000	(100,000)
47114	USDA-Other	15,783	15,000	15,000	15,000	0
	Total Federal Government	1,886,080	1,900,000	1,900,000	1,560,000	(340,000)
	Total Estimated Revenues	2,105,856	2,114,700	2,114,700	2,174,300	59,600
49000	<u>ESTIMATED OTHER SOURCES(NON-REVENUE)</u>					
49800	Transfer In	0	0	0	0	0
	TOTAL ESTIMATE OTHER SOURCES	0	0	0	0	0
	TOTAL ESTIMATED REVENUE AND OTHE	2,105,856	2,114,700	2,114,700	2,174,300	59,600

Hickman County Tennessee
 Central Cafeteria Fund 143
 Statement of Proposed Operations
 For the Fiscal Year Ending June 30, 2021

Account No	Description	Actual 2018-2019	Original Estimated 2019-2020	Amended Estimated 2019-2020	Estimated 2020-2021	Difference 2020-2021
<u>ESTIMATED EXPENDITURES</u>						
73000	<u>OPERATION OF NON-INSTRUCTIONAL SERVICES</u>					
73100	<u>Food Services</u>					
105	Supervisor/Director	29,853	33,000	33,000	37,000	4,000
119	Accountants/Bookkeeper	118,857	116,071	116,071	122,000	5,929
165	Cafeteria Personnel	508,510	514,850	514,850	525,000	10,150
201	Social Security	48,943	50,790	50,790	52,326	1,536
204	State Retirement	77,483	91,488	91,488	75,445	(16,043)
207	Medical Insurance	22,000	35,000	35,000	45,000	10,000
210	Unemployment Compensation	0	6,500	6,500	6,500	0
307	Communication	6,903	6,000	6,000	4,000	(2,000)
336	Maint & Repair Services - Equipment	46,534	46,000	46,000	50,000	4,000
354	Transportation - Other than Students	3,075	6,000	6,000	6,000	0
355	Travel	1,717	2,000	2,000	2,000	0
399	Other Contracted Services	53,766	48,000	48,000	55,000	7,000
422	Food Supplies	967,001	1,010,000	1,010,000	1,040,000	30,000
452	Utilities	2,398	4,000	4,000	4,000	0
469	USDA-Commodities	101,623	0	0		0
499	Other Supplies and Materials	88,822	95,000	95,000	100,000	5,000
599	Other Charges	11,177	15,000	15,000	15,000	15,000
710	Food Service Equipment	4,865	35,000	35,000	35,000	35,000
	Total Food Service	2,093,527	2,114,699	2,114,699	2,174,271	59,572
	Total Estimated Expenditures	2,093,527	2,114,699	2,114,699	2,174,271	59,572
	Excess of Estimated Revenues Over (Under) Estimated Expenditures	12,329	1	1	29	28
	Estimated Beginning Fund Balance July 1	455,179	467,508	467,508	500,000	32,493
	Estimated Ending Fund Balance June 30	467,508	467,509	467,509	500,029	32,520

500,000 OF FUND BALANCE BELONGS TO GPS FUND(141)

April 4, 2016

Hickman County School Board Memebers

Provided is a rough draft of the Proposed FY 2021 Budget for the Hickman County Schools. Listed below are some of the assumptions used in creating this first pass of the budget and some of the current limitations that will be addressed in the coming weeks. Our goal is to have a finalized budget for the board's approval at the May 4th board meeting. We will continue working and finetuning the budget during the coming weeks and providing updates and additional information and details.

- It is assumed that the Local Revenue portion of the budget will remain the same. Depending on the length of this crisis and the length of the recovery will determine if next year Local Revenues will exceed, meet, or fall short of budgeted revenues.
- At this time we have not been provided BEP funding estimates from the state
- The budget recently passed by the state included a 2% percent increase to instructional salaries funded through the BEP. This was a reduction from the 4% originally proposed by the government.
- With the current crisis we were not comfortable with providing a year-end projection for the current budget year with this draft. We will be working on those estimates this coming week.
- This budget includes a 1.25% increase to the BEP Salary schedule used last year. Also, included in the BEP Salary Schedule are the bonuses paid this year (as part of the salary, not as a separate line item). Other instructional salary schedules for Principals and 12-month Asst. Principals included a 1.25% increase in the schedules.
- Non-licensed pay scales were not changed from the current pay scales. Increases for non-licensed employees will be based on the step increase.
- Budgeted Capital Projects have been reduced significantly.
 - The proposed bus purchase, while budgeted at \$600,000 will have a net cost of approximately \$300,000.
- The Revenues that are currently listed for the FY 2021 budget are the same revenues currently in the FY 2020 budget. They will be updated as additional details are provided from the state and county and additional analysis are made.
- Listed below are the categories with anticipated surplus (approximations) in the budget:
 - Medical Insurance - \$200,000
 - TNRMT Insurance - \$200,000
 - Utilities - \$100,000
 - Payroll - \$200,000

- Next week you will be provided with a detailed HC by line-item for this budget.

As always, if you see something that does not look right, or something that appears to be calculating incorrectly let us know.

If you have any questions, or need additional information please contact me at mike.elkins@hickmank12.org or via my cell phone at 931-994-8247. We will continue to review, analyze, and fine tune this budget daily up to our next board meeting. Thank you for any feedback and input you can provide.

Hickman County Schools
Summary of Previous Completed Budget Years

	Revenues		Expenditures		Actual	
	Budget	Actual	Budget	Actual	Revenues	Expenditures
FY 15	\$ 27,021,584	\$ 26,372,938	\$ 29,215,789	\$ 27,105,083	\$ 26,372,938	\$ 27,105,083
FY 16	\$ 27,089,469	\$ 27,009,522	\$ 29,397,561	\$ 26,829,350	\$ 27,009,522	\$ 26,829,350
FY 17	\$ 27,603,484	\$ 27,377,869	\$ 30,565,001	\$ 26,185,824	\$ 27,377,869	\$ 26,185,824
FY 18	\$ 27,978,562	\$ 28,048,370	\$ 30,369,311	\$ 27,666,728	\$ 28,048,370	\$ 27,666,728
FY 19	\$ 28,400,812	\$ 28,573,275	\$ 31,445,252	\$ 28,273,430	\$ 28,573,275	\$ 28,273,430
		% of Bdgt	% of Bdgt	% of Bdgt	% of Rev	% of Rev
		97.60%	92.78%	91.26%	102.78%	99.33%
		99.18%	85.67%	91.10%	95.65%	98.64%
		100.25%	89.91%		98.95%	

FY 17 First year of Operations under Michelle Gilbert

FY 18 First budget submitted by Michelle Gilbert

FY 19 Removed significant budgeted surplus from line 71100-116 (Regular Instruction - Teachers) in order to provide more accurate estimate for teacher salaries with required budgeted instructional salary increase from state.

FY 20 Removed significant budgeted surplus from Obj 207 (Medical Insurance) in order to provide more accurate estimate for Medical Insurance cost estimates while maintaining a reasonable surplus for unanticipated enrollment increases.

**Hickman County Capital Outlay Projects
2020-2021**

Gym HVAC units at EHMS/EHES	72610-720	\$85,000
EHHS Parking Lot Curtain Drains	76100-790	\$80,000
Technology Infrastructure and Hardware	71000-722	\$100,000
	72250-722	\$50,000
HCHS ADA Compliance for CTE Workstations	76100-790	\$25,000
School Buses (6)	72710-729	\$600,000
Total		\$940,000

Total	Personnel Related	\$21,644,602	\$22,392,419	\$24,472,581	\$24,628,257	0.64%
Total	Non-Personnel Related	\$ 6,102,902	\$ 5,881,011	\$ 7,254,170	\$ 6,812,661	-6.09%
Total	Expenditures	\$27,747,504	\$28,273,430	\$31,726,752	\$31,440,919	-0.90%
	Surplus/(Defecit)	\$ 300,865	\$ 299,846	\$ (2,520,573)		

HICKMAN COUNTY SCHOOLS
FY 2020-21 BUDGET WORKSHEET
as of April 6, 2020

Account	Description	FY 2018	FY 2019	FY 2020	FY 2021	
		Revenues	Actual	Budget	Budget	%Inc/(Dec)
40110	Current Property Tax	\$ 3,025,888	\$ 3,078,528	\$ 2,965,472	\$ 2,965,472	0.00%
40120	Trustee's Collections - Prior Year	\$ 99,904	\$ 107,138	\$ 100,000	\$ 100,000	0.00%
40130	Cir Clk/Clk & Master Collections-Pr Yr	\$ 61,768	\$ 71,894	\$ 55,000	\$ 55,000	0.00%
40140	Interest And Penalty	\$ 20,029	\$ 19,544	\$ 21,000	\$ 21,000	0.00%
40161	Payments In Lieu Of Taxes - T. V. A.	\$ 3,615	\$ 3,596	\$ 4,000	\$ 4,000	0.00%
40162	Payments In Lieu Of Taxes-Local	\$ 6,000	\$ 6,000	\$ 6,000	\$ 6,000	0.00%
40210	Local Option Sales Tax	\$ 1,490,514	\$ 1,615,858	\$ 1,600,000	\$ 1,600,000	0.00%
40270	Business Tax	\$ 35,140	\$ 33,753	\$ 30,000	\$ 30,000	0.00%
40320	Bank Excise Tax	\$ -	\$ -	\$ 30,000	\$ 30,000	0.00%
40350	Interstate Telecommunications Tax	\$ -	\$ -	\$ 1,500	\$ 1,500	0.00%
41110	Marriage Licenses	\$ 1,454	\$ 1,454	\$ 1,300	\$ 1,300	0.00%
43513	Tuition - Summer School	\$ 3,596	\$ -	\$ 1,000	\$ 1,000	0.00%
43517	Tuition - Other	\$ -	\$ 5,578	\$ 1,000	\$ 1,000	0.00%
43570	Receipts From Individual Schools	\$ 50,907	\$ 51,530	\$ 60,000	\$ 60,000	0.00%
43582	Community Service Fees - Adults	\$ 198	\$ 140	\$ 200	\$ 200	0.00%
44120	Lease/Rentals	\$ 2,570	\$ 830	\$ 1,000	\$ 1,000	0.00%
44146	E-Rate Funding	\$ 16,168	\$ -	\$ 15,000	\$ 15,000	0.00%
44160	Retirees' Insurance Payments	\$ -	\$ -	\$ -	\$ -	0.00%
44170	Miscellaneous Refunds	\$ 38,637	\$ 8,184	\$ 28,100	\$ 28,100	0.00%
44530	Sale Of Equipment	\$ 3,931	\$ -	\$ 5,000	\$ 5,000	0.00%
44560	Damages Recovered From Individuals	\$ 603	\$ 379	\$ 3,000	\$ 3,000	0.00%
44570	Contributions & Gifts	\$ 8,610	\$ 11,210	\$ 15,000	\$ 15,000	0.00%
44990	Other Local Revenues	\$ 33,405	\$ 2,500	\$ -	\$ -	0.00%
46511	Basic Education Program	\$21,671,000	\$22,085,838	\$22,360,000	\$22,360,000	0.00%
46515	Early Childhood Education	\$ 436,511	\$ 423,212	\$ 419,362	\$ 419,362	0.00%
46520	School Food Service	\$ 20,252	\$ 20,073	\$ 22,000	\$ 22,000	0.00%
46550	Driver Education	\$ 5,939	\$ 8,249	\$ 10,000	\$ 10,000	0.00%
46590	Other State Education Funds	\$ 251,584	\$ 232,629	\$ 250,000	\$ 250,000	0.00%
46591	Coordinated School Health - ARRA	\$ 90,000	\$ 90,000	\$ 90,000	\$ 90,000	0.00%
46594	Family Resource Centers - ARRA	\$ 59,223	\$ 59,223	\$ 59,223	\$ 59,223	0.00%
46610	Career Ladder Program	\$ 73,185	\$ 73,077	\$ 60,000	\$ 60,000	0.00%
46640	Vocational Equipment	\$ 149,991	\$ -	\$ -	\$ -	0.00%
46851	State Revenue Sharing -T.V.A.	\$ 222,695	\$ 234,141	\$ 250,000	\$ 250,000	0.00%
46980	Other State Grants	\$ 50,000	\$ 36,800	\$ 406,536	\$ 406,536	0.00%
46981	Safe Schools	\$ 22,030	\$ 95,057	\$ 104,023	\$ 104,023	0.00%
46990	Other State Revenues	\$ 8,710	\$ 65,433	\$ 25,062	\$ 25,062	0.00%
47590	Other Federal Through State	\$ 1,430	\$ 895	\$ -	\$ -	0.00%
47640	Rotc Reimbursement	\$ 57,210	\$ 60,734	\$ 65,000	\$ 65,000	0.00%
48990	Other	\$ -	\$ 46,975	\$ 106,400	\$ 106,400	0.00%
49700	Insurance Recovery	\$ -	\$ -	\$ 10,000	\$ 10,000	0.00%
49800	Transfers In	\$ 25,673	\$ 22,823	\$ 25,000	\$ 25,000	0.00%
49951	Spccial Item (Revenue) - No. 1	\$ -	\$ -	\$ -	\$ -	0.00%
Total	Revenues	\$28,048,370	\$28,573,275	\$29,206,179	\$29,206,179	0.000%

Total	Personnel Related	\$ 21,644,602	\$ 22,392,419	\$24,472,581	\$24,628,257	0.64%
Total	Non-Personnel Related	\$ 6,102,902	\$ 5,881,011	\$ 7,254,170	\$ 6,812,661	-6.09%
Total		\$ 27,747,504	\$ 28,273,430	\$31,726,752	\$31,440,919	-0.90%
		\$ 300,865	\$ 299,846	\$ (2,520,573)		

HICKMAN COUNTY SCHOOLS
FY 2020-21 BUDGET WORKSHEET
as of April 6, 2020

Program Object	Description	FY 2018 Expenditures	FY 2019 Expenditures	FY 2020 Budget	FY 2021 Budget	% Inc/Dec
71100	Regular Instruction Program					
71100 116	Teachers	\$ 8,281,258	\$ 8,506,781	\$ 8,639,010	\$ 9,189,095	6.37%
71100 117	Career Ladder Program	\$ 65,500	\$ 54,180	\$ 60,000	\$ 75,000	25.00%
71100 128	Homebound Teachers		600	\$ 12,000	\$ 12,000	0.00%
71100 140	Salary Supplements	\$ 305,526	\$ 287,276	\$ 342,515	\$ 310,318	-9.40%
71100 163	Educational Assistants	\$ 295,239	\$ 317,910	\$ 332,000	\$ 352,000	6.02%
71100 188	Bonus Payments			\$ 361,700		-100.00%
71100 189	Other Salaries & Wages	\$ 311,652	\$ 356,681	\$ 400,000	\$ 400,000	0.00%
71100 198	Non-Certified Substitute Teachers	\$ 120,730	\$ 133,406	\$ 146,000	\$ 146,000	0.00%
71100 201	Social Security	\$ 695,830	\$ 714,011	\$ 787,432	\$ 802,058	1.86%
71100 204	State Retirement	\$ 785,582	\$ 935,881	\$ 1,072,142	\$ 1,074,110	0.18%
71100 207	Medical Insurance	\$ 1,441,393	\$ 1,494,415	\$ 1,400,000	\$ 1,400,000	0.00%
71100 217	Retirement - Hybrid Stabilization		\$ 67,519			#DIV/0!
71100 336	Maintenance And Repair Services-Equipment		\$ 434	\$ 8,000	\$ 8,000	0.00%
71100 399	Other Contracted Services	\$ 29,148	\$ 32,913	\$ 32,500	\$ 35,000	7.69%
71100 429	Instructional Supplies And Materials	\$ 97,004	\$ 102,490	\$ 117,000	\$ 117,000	0.00%
71100 449	Textbooks	\$ 221,339	\$ 208,339	\$ 200,000	\$ 300,000	50.00%
71100 499	Other Supplies And Materials	\$ 241	\$ 8,533	\$ 8,000	\$ 8,000	0.00%
71100 722	Regular Instruction Equipment	\$ 149,931	\$ 150,548	\$ 100,000	\$ 100,000	0.00%
Total	Personnel Related	\$ 12,302,710	\$ 12,888,660	\$13,552,799	\$13,760,581	1.53%
Total	Non-Personnel Related	\$ 497,663	\$ 503,258	\$ 465,500	\$ 568,000	22.02%
71100 Total	Regular Instruction Program	\$ 12,800,373	\$ 13,391,917	\$14,018,299	\$14,328,581	2.21%

The Regular Education Program includes activities that provide students in grades K through 12 with learning experiences to prepare them for such activities as citizens, family members, and members of the work force. Expenditures for instructing students should be recorded in this program.

- 71100-189 \$315k for Differentiated Pay Plan
- 71100-429 \$85k for BEP, \$32k for Schools (\$4k per school)
- 71100-722 Chromebooks for schools
- 71100-449 Reading Adoption

Total	Personnel Related	\$ 21,644,602	\$ 22,392,419	\$24,472,581	\$24,628,257
Total	Non-Personnel Related	\$ 6,102,902	\$ 5,881,011	\$ 7,254,170	\$ 6,812,661
Total		\$ 27,747,504	\$ 28,273,430	\$31,726,752	\$31,440,919
		\$ 300,865	\$ 299,846	\$ (2,520,573)	

HICKMAN COUNTY SCHOOLS
FY 2020-21 BUDGET WORKSHEET
as of April 6, 2020

Program Object	Description	FY 2018 Expenditures	FY 2019 Expenditures	FY 2020 Budget	FY 2021 Budget	% Inc/Dec
71150	Alternative Instruction Program					
71150 116	Teachers	\$ 92,200	\$ 97,400	\$ 99,939	\$ 108,600	8.67%
71150 163	Educational Assistants	\$ 16,980	\$ 17,470	\$ 18,500	\$ 18,500	0.00%
71150 188	Bonus			\$ 9,100		-100.00%
71150 201	Social Security	\$ 7,323	\$ 8,382	\$ 9,757	\$ 9,723	-0.34%
71150 204	State Retirement	\$ 10,424	\$ 12,591	\$ 14,140	\$ 13,703	-3.09%
71150 207	Medical Insurance	\$ 18,486	\$ 15,846	\$ 18,000	\$ 18,000	0.00%
71150 429	Instructional Supplies And Materials		\$ 323	\$ 500	\$ 500	0.00%
71150 499	Other Supplies And Materials		\$ 98	\$ 500	\$ 500	0.00%
Total	Personnel Related	\$ 145,413	\$ 151,689	\$ 169,436	\$ 168,526	-0.54%
Total	Non-Personnel Related	\$ -	\$ 421	\$ 1,000	\$ 1,000	0.00%
71150 Total	Alternative Instruction Program	\$ 145,413	\$ 152,110	\$ 170,436	\$ 169,526	-0.53%

Alternative Schools Program is an instructional program designated for students who consistently exhibit behavior that is disruptive to the learning process or violent in nature. This program may also serve at-risk youth with special needs. This program includes activities that deal directly with the interaction between teachers and students in an alternative learning environment. Included here are the activities of aides or classroom assistants of any type (clerks, graders, teaching assistants, etc.) which assist in the instructional process. The major categories in the Alternative School Program include personnel, benefits, supplies and materials, textbooks, contracted services and equipment needed to deliver instructional services to students. Instructional programs for gifted students

Total	Personnel Related	\$ 21,644,602	\$ 22,392,419	\$24,472,581	\$24,628,257
Total	Non-Personnel Related	\$ 6,102,902	\$ 5,881,011	\$ 7,254,170	\$ 6,812,661
Total		\$ 27,747,504	\$ 28,273,430	\$31,726,752	\$31,440,919
		\$ 300,865	\$ 299,846	\$ (2,520,573)	

HICKMAN COUNTY SCHOOLS
FY 2020-21 BUDGET WORKSHEET
as of April 6, 2020

Program Object	Description	FY 2018 Expenditures	FY 2019 Expenditures	FY 2020 Budget	FY 2021 Budget	% Inc/Dec
71200	Special Education Program					
71200 116	Teachers	\$ 1,487,665	\$ 1,462,209	\$ 1,601,850	\$ 1,625,000	1.45%
71200 124	Psychological Personnel	\$ -	\$ -	\$ 60,000	\$ 63,000	5.00%
71200 128	Homebound Teachers	\$ 16,913	\$ 20,596	\$ 22,900	\$ 23,000	0.44%
71200 163	Educational Assistants	\$ 188,995	\$ 184,118	\$ 210,000	\$ 230,000	9.52%
71200 171	Speech Pathologist	\$ 101,482	\$ 176,175	\$ 188,970	\$ 201,050	6.39%
71200 188	Bonus	\$ -	\$ -	\$ 78,800	\$ -	-100.00%
71200 198	Non-Certified Substitute Teachers	\$ 128,437	\$ 132,039	\$ 165,433	\$ 163,867	-0.95%
71200 201	Social Security	\$ 164,365	\$ 151,539	\$ 236,449	\$ 228,016	-3.57%
71200 204	State Retirement	\$ 275,000	\$ 290,000	\$ 330,000	\$ 320,000	-3.03%
71200 207	Medical Insurance	\$ 204,230	\$ 198,969	\$ 180,000	\$ 195,000	8.33%
71200 399	Other Contracted Services	\$ 2,362,857	\$ 2,416,675	\$ 2,894,402	\$ 2,853,932	-1.40%
Total	Personnel Related	\$ 2,362,857	\$ 2,416,675	\$ 2,894,402	\$ 2,853,932	-1.40%
Total	Non-Personnel Related	\$ 204,230	\$ 198,969	\$ 180,000	\$ 195,000	8.33%
71200 Total	Special Education Program	\$ 2,567,088	\$ 2,615,644	\$ 3,074,402	\$ 3,048,932	-0.83%

The Special Education Program includes activities that provide learning experiences for students having special needs. This includes pre-school as well as elementary and secondary students. Services include activities for varying needs. This includes educating the gifted and those with learning, emotional and physical disabilities. A student is educated based on an Individual Education Plan (IEP) developed by a team who address the particular needs of the student.

Total	Personnel Related	\$ 21,644,602	\$ 22,392,419	\$24,472,581	\$24,628,257
Total	Non-Personnel Related	\$ 6,102,902	\$ 5,881,011	\$ 7,254,170	\$ 6,812,661
Total		\$ 27,747,504	\$ 28,273,430	\$31,726,752	\$31,440,919
		\$ 300,865	\$ 299,846	\$ (2,520,573)	

HICKMAN COUNTY SCHOOLS
FY 2020-21 BUDGET WORKSHEET
as of April 6, 2020

Program Object	Description	FY 2018 Expenditures	FY 2019 Expenditures	FY 2020 Budget	FY 2021 Budget	% Inc/Dec
71300	Career & Technical Education					
71300 116	Teachers	\$ 657,330	\$ 695,781	\$ 741,790	\$ 770,000	3.80%
71300 140	Supplement		\$ 6,000	\$ 12,000	\$ 12,000	0.00%
188	Bonus			\$ 38,100		-100.00%
71300 198	Non-Certified Substitute Teachers	\$ 14,976	\$ 10,688	\$ 15,000	\$ 15,000	0.00%
71300 201	Social Security	\$ 49,790	\$ 53,156	\$ 61,727	\$ 60,971	-1.23%
71300 204	State Retirement	\$ 59,686	\$ 60,602	\$ 84,178	\$ 83,127	-1.25%
71300 207	Medical Insurance	\$ 87,316	\$ 91,932	\$ 101,000	\$ 101,000	0.00%
399	Other Contracted Services		\$ 15,000	\$ 7,500	\$ 15,000	100.00%
71300 429	Instructional Supplies And Materials					
71300 499	Other Supplies And Materials	\$ 14,125	\$ 12,185	\$ 16,500	\$ 15,000	-9.09%
71300 730	Vocational Instruction Equipment	\$ 149,991		\$ 72,900	\$ 32,000	-56.10%
71300 790	Other Equipment	\$ 23,712	\$ 25,690			
Total	Personnel Related	\$ 869,098	\$ 918,159	\$ 1,053,795	\$ 1,042,097	-1.11%
Total	Non-Personnel Related	\$ 187,828	\$ 52,875	\$ 96,900	\$ 62,000	-36.02%
71300 Total	Career & Technical Education	\$ 1,056,926	\$ 971,034	\$ 1,150,695	\$ 1,104,097	-4.05%

The Vocational Education Program includes instructional activities that provide students with the opportunity to develop knowledge, skills, and attitudes needed for employment in an occupational area. Activities include training both in the classroom and in a supervised work environment.

Total	Personnel Related	\$ 21,644,602	\$ 22,392,419	\$24,472,581	\$24,628,257
Total	Non-Personnel Related	\$ 6,102,902	\$ 5,881,011	\$ 7,254,170	\$ 6,812,661
Total		\$ 27,747,504	\$ 28,273,430	\$31,726,752	\$31,440,919
		\$ 300,865	\$ 299,846	\$ (2,520,573)	

**HICKMAN COUNTY SCHOOLS
FY 2020-21 BUDGET WORKSHEET
as of April 6, 2020**

Program Object	Description	FY 2018 Expenditures	FY 2019 Expenditures	FY 2020 Budget	FY 2021 Budget	% Inc/Dec
72110	Attendance					
72110 105	Supervisor/Director	\$ 61,435	\$ 67,360	\$ 74,500	\$ 73,000	-2.01%
72110 189	Other Salaries & Wages	\$ 23,813	\$ 30,175	\$ 31,500	\$ 31,500	0.00%
72110 201	Social Security	\$ 6,701	\$ 7,449	\$ 8,109	\$ 7,994	-1.42%
72110 204	State Retirement	\$ 10,054	\$ 6,189	\$ 11,088	\$ 11,277	1.71%
72110 207	Medical Insurance	\$ 10,782	\$ 7,472	\$ 11,850	\$ 11,850	0.00%
72110 331	Legal Services					
72110 355	Travel	\$ 2,754	\$ 2,558	\$ 5,000	\$ 5,000	0.00%
72110 399	Other Contracted Services	\$ 8,888	\$ 12,000	\$ 12,000	\$ 12,000	0.00%
72110 499	Other Supplies And Materials	\$ 1,471	\$ 1,830	\$ 2,000	\$ 2,000	0.00%
72110 524	Inservice	\$ 920	\$ 340	\$ 1,000	\$ 1,000	0.00%
72110 722	Regular Instruction Equipment					
Total	Personnel Related	\$ 112,785	\$ 118,645	\$ 137,047	\$ 135,621	-1.04%
Total	Non-Personnel Related	\$ 14,033	\$ 16,729	\$ 20,000	\$ 20,000	0.00%
Total	Attendance	\$ 126,818	\$ 135,373	\$ 157,047	\$ 155,621	-0.91%

Attendance services are activities designed to improve student attendance at school and which attempt to prevent or to solve student problems involving the home, the school, and the community. Major categories include personnel, benefits, supplies and materials, and other charges.

- Personnel
- At-Risk Coordinator
 - Student Management System Administrator - (0.5 FTE)

Total	Personnel Related	\$ 21,644,602	\$ 22,392,419	\$24,472,581	\$24,628,257
Total	Non-Personnel Related	\$ 6,102,902	\$ 5,881,011	\$ 7,254,170	\$ 6,812,661
Total		\$ 27,747,504	\$ 28,273,430	\$31,726,752	\$31,440,919
		\$ 300,865	\$ 299,846	\$ (2,520,573)	

HICKMAN COUNTY SCHOOLS
FY 2020-21 BUDGET WORKSHEET
as of April 6, 2020

Program Object	Description	FY 2018 Expenditures	FY 2019 Expenditures	FY 2020 Budget	FY 2021 Budget	% Inc/Dec
72120	Health Services					
72120 131	Medical Personnel	\$ 134,116	\$ 136,792	\$ 150,600	\$ 150,600	0.00%
72120 189	Other Salaries & Wages	\$ 98,902	\$ 99,503	\$ 102,339	\$ 102,750	0.40%
72120 201	Social Security	\$ 17,250	\$ 17,487	\$ 19,350	\$ 19,381	0.16%
72120 204	State Retirement	\$ 21,168	\$ 19,754	\$ 26,457	\$ 26,019	-1.66%
72120 207	Medical Insurance	\$ 33,344	\$ 35,400	\$ 40,000	\$ 40,000	0.00%
72120 355	Travel	\$ 1,397	\$ 2,901	\$ 3,500	\$ 3,500	0.00%
72120 399	Other Contracted Services	\$ 2,988	\$ 3,110	\$ 4,000	\$ 4,000	0.00%
72120 413	Drugs And Medical Supplies	\$ 3,350	\$ 2,327	\$ 3,300	\$ 3,500	6.06%
72120 499	Other Supplies And Materials	\$ 20,857	\$ 4,251	\$ 2,700	\$ 3,000	11.11%
72120 524	Inservice	\$ 599	\$ 554	\$ 1,500	\$ 2,000	33.33%
72120 735	Health Equipment	\$ 20,547	\$ -	\$ 9,000	\$ 8,000	-11.11%
Total	Personnel Related	\$ 304,781	\$ 308,936	\$ 338,746	\$ 338,750	0.00%
Total	Non-Personnel Related	\$ 49,738	\$ 13,143	\$ 24,000	\$ 24,000	0.00%
72120 Total	Health Services	\$ 354,519	\$ 322,079	\$ 362,746	\$ 362,750	0.00%

Health Support Services are activities that provide physical and mental health services that are not direct instruction. Services are also provided for appropriate medical and nursing services as required by individual program needs that include medical supplies, materials and equipment.

Total	Personnel Related	\$ 21,644,602	\$ 22,392,419	\$24,472,581	\$24,628,257
Total	Non-Personnel Related	\$ 6,102,902	\$ 5,881,011	\$ 7,254,170	\$ 6,812,661
Total		\$ 27,747,504	\$ 28,273,430	\$31,726,752	\$31,440,919
		\$ 300,865	\$ 299,846	\$ (2,520,573)	

HICKMAN COUNTY SCHOOLS
FY 2020-21 BUDGET WORKSHEET
as of April 6, 2020

Program Object	Description	FY 2018 Expenditures	FY 2019 Expenditures	FY 2020 Budget	FY 2021 Budget	% Inc/Dec
72130	Other Student Support					
72130	123 Guidance Personnel	\$ 518,621	\$ 491,039	\$ 547,680	\$ 572,490	4.53%
	188			\$ 16,250		-100.000%
72130	189 Other Salaries & Wages		\$ 75,400	\$ 76,650	\$ 80,760	5.36%
72130	201 Social Security	\$ 37,983	\$ 40,970	\$ 49,004	\$ 49,974	1.98%
72130	204 State Retirement	\$ 47,091	\$ 48,694	\$ 68,094	\$ 67,089	-1.48%
72130	207 Medical Insurance	\$ 62,264	\$ 62,846	\$ 65,000	\$ 65,000	0.00%
72130	322 Evaluation And Testing	\$ 12,106	\$ 9,702	\$ 20,000	\$ 20,000	0.00%
72130	344 Payments To Schools-Other	\$ 2,000	\$ 80,000	\$ 72,000	\$ 80,000	11.11%
72130	355 Travel	\$ 2,470	\$ 2,497	\$ 2,500	\$ 3,000	20.00%
72130	399 Other Contracted Services	\$ 21,566	\$ 21,464	\$ 23,000	\$ 23,000	0.00%
72130	499 Other Supplies And Materials	\$ 398	\$ 3,690	\$ 4,000	\$ 4,000	0.00%
72130	524 Inservice		\$ 715	\$ 3,000	\$ 3,000	0.00%
Total	Personnel Related	\$ 665,959	\$ 716,949	\$ 822,678	\$ 835,312	1.54%
Total	Non-Personnel Related	\$ 38,540	\$ 118,068	\$ 124,500	\$ 133,000	6.83%
72130	Total Other Student Support	\$ 704,498	\$ 835,018	\$ 947,178	\$ 968,312	2.23%

Other Student Support includes services to students in addition to attendance and health services. These include guidance services, and evaluation and testing services for both Regular Education students, Special Education students, and Vocational Education students.

- 72130-344 \$10k for each School
- 72130-399 Pearson Contract
- 72130-499 \$500 per school
- 72130-524 \$575 per school

Total	Personnel Related	\$ 21,644,602	\$ 22,392,419	\$24,472,581	\$24,628,257
Total	Non-Personnel Related	\$ 6,102,902	\$ 5,881,011	\$ 7,254,170	\$ 6,812,661
Total		\$ 27,747,504	\$ 28,273,430	\$31,726,752	\$31,440,919
		\$ 300,865	\$ 299,846	\$ (2,520,573)	

HICKMAN COUNTY SCHOOLS
FY 2020-21 BUDGET WORKSHEET
as of April 6, 2020

Program Object	Description	FY 2018 Expenditures	FY 2019 Expenditures	FY 2020 Budget	FY 2021 Budget	% Inc/Dec
72210	Regular Education Instructional Support					
72210 105	Supervisor/Director	\$ 68,507	\$ 75,000	\$ 76,650	\$ 78,820	2.83%
72210 129	Librarians	\$ 373,600	\$ 355,919	\$ 405,650	\$ 420,000	3.54%
72210 161	Secretary(s)	\$ 188,105	\$ 183,132	\$ 182,000	\$ 182,000	0.00%
72210 162	Clerical Personnel	\$ 173,544	\$ 175,833	\$ 205,000	\$ 210,000	2.44%
188				\$ 24,000		-100.00%
72210 189	Other Salaries & Wages	\$ 34,002	\$ 36,551	\$ 38,325	\$ 20,000	-47.81%
72210 201	Social Security	\$ 62,148	\$ 61,042	\$ 71,269	\$ 69,678	-2.23%
72210 204	State Retirement	\$ 93,066	\$ 87,966	\$ 111,222	\$ 107,300	-3.53%
72210 207	Medical Insurance	\$ 132,214	\$ 154,980	\$ 158,000	\$ 158,000	0.00%
72210 336	Maintenance And Repair Services-Equipment			\$ 2,500	\$ 2,500	0.00%
72210 355	Travel	\$ 4,024	\$ 5,525	\$ 5,000	\$ 5,000	0.00%
72210 399	Other Contracted Services	\$ 200	\$ 554	\$ 12,000	\$ 12,000	0.00%
72210 429	Instructional Supplies And Materials			\$ 2,500		-100.00%
72210 432	Library Books/Media	\$ 4,000	\$ 4,000	\$ 4,000	\$ 4,000	0.00%
72210 499	Other Supplies And Materials	\$ 283	\$ 269	\$ 3,600	\$ 3,600	0.00%
72210 524	Inservise	\$ 198	\$ 1,154	\$ 2,000	\$ 2,000	0.00%
72210 722	Regular Instruction Equipment			\$ 7,500	\$ 7,500	0.00%
72210 790	Other Equipment			\$ 43,140	\$ 10,000	-76.82%
Total	Personnel Related	\$ 1,125,186	\$ 1,130,422	\$ 1,272,117	\$ 1,245,798	-2.07%
Total	Non-Personnel Related	\$ 8,705	\$ 11,502	\$ 82,240	\$ 46,600	-43.34%
72210 Total	Regular Education Instructional Support	\$ 1,133,891	\$ 1,141,924	\$ 1,354,357	\$ 1,292,398	-4.57%

Regular Education Instructional Support includes activities primarily for assisting instructional staff in planning, developing, and evaluating the process of providing learning experiences for students. These activities include curriculum development, techniques of instruction, child development and understanding.

- 72210-432 \$1k per school
- 72210-524 Inservise for Librarians and Regular Instruction Supervisor
- 72210-722 Contingency for unanticipated equipment needs

Total	Personnel Related	\$ 21,644,602	\$ 22,392,419	\$24,472,581	\$24,628,257
Total	Non-Personnel Related	\$ 6,102,902	\$ 5,881,011	\$ 7,254,170	\$ 6,812,661
Total		\$ 27,747,504	\$ 28,273,430	\$31,726,752	\$31,440,919
		\$ 300,865	\$ 299,846	\$ (2,520,573)	

HICKMAN COUNTY SCHOOLS
FY 2020-21 BUDGET WORKSHEET
as of April 6, 2020

Program Object	Description	FY 2018 Expenditures	FY 2019 Expenditures	FY 2020 Budget	FY 2021 Budget	% Inc/Dec
72220	Special Education Instructional Support					
72220 105	Supervisor/Director	\$ 67,839	\$ 69,184	\$ 72,933	\$ 75,035	2.88%
72220 189	Other Salaries & Wages	\$ 3,853	\$ 4,700	\$ 5,000	\$ 5,000	0.00%
72220 196	In-Service Training	\$ 2,111	\$ 1,343	\$ 3,500	\$ 3,500	0.00%
72220 201	Social Security	\$ 5,484	\$ 5,412	\$ 6,230	\$ 6,390	2.58%
72220 204	State Retirement	\$ 6,884	\$ 7,461	\$ 8,800	\$ 8,877	0.88%
72220 207	Medical Insurance	\$ 3,400	\$ 6,444	\$ 7,900	\$ 7,900	0.00%
72220 336	Maintenance And Repair Services-Equipment	\$ 4,174	\$ 3,948	\$ 5,000	\$ 5,000	0.00%
72220 355	Travel	\$ 5,557	\$ 6,763	\$ 6,000	\$ 7,500	25.00%
Total	Personnel Related	\$ 89,592	\$ 94,543	\$ 104,363	\$ 106,703	2.24%
Total	Non-Personnel Related	\$ 9,731	\$ 10,711	\$ 11,000	\$ 12,500	13.64%
72220 Total	Special Education Instructional Support	\$ 99,323	\$ 105,254	\$ 115,363	\$ 119,203	3.33%

Special Education Instruction Support includes activities primarily for assisting instructional staff in planning, developing, and evaluating the process of providing learning experiences for students with special needs. These activities include curriculum development, techniques of instruction, child development

Total	Personnel Related	\$ 21,644,602	\$ 22,392,419	\$24,472,581	\$24,628,257
Total	Non-Personnel Related	\$ 6,102,902	\$ 5,881,011	\$ 7,254,170	\$ 6,812,661
Total		\$ 27,747,504	\$ 28,273,430	\$31,726,752	\$31,440,919
		\$ 300,865	\$ 299,846	\$ (2,520,573)	

HICKMAN COUNTY SCHOOLS
FY 2020-21 BUDGET WORKSHEET
as of April 6, 2020

Program Object	Description	FY 2018 Expenditures	FY 2019 Expenditures	FY 2020 Budget	FY 2021 Budget	% Inc/Dec
72230	Career & Technical Education Instructional Supp					
72230 105	Supervisor/Director	\$ 71,720	\$ 72,920	\$ 83,425	\$ 79,521	-4.68%
72230 201	Social Security	\$ 5,414	\$ 5,506	\$ 6,382	\$ 6,083	-4.68%
72230 204	State Retirement	\$ 6,512	\$ 7,627	\$ 8,726	\$ 8,167	-6.41%
72230 207	Medical Insurance	\$ 6,800	\$ 7,900	\$ 7,900	\$ 7,900	0.00%
72230 336	Maintenance And Repair Services-Equipment	\$ 150	\$ 990	\$ 3,000	\$ 3,000	0.00%
72230 355	Travel	\$ 401	\$ 877	\$ 2,500	\$ 2,000	-20.00%
72230 499	Other Supplies And Materials	\$ 1,201	\$ 2,868	\$ 3,000	\$ 3,000	0.00%
Total	Personnel Related	\$ 90,446	\$ 93,953	\$ 106,433	\$ 101,671	-4.47%
Total	Non-Personnel Related	\$ 1,752	\$ 4,735	\$ 8,500	\$ 8,000	-5.88%
72230 Total	Career & Technical Education Instructional Supp	\$ 92,198	\$ 98,688	\$ 114,933	\$ 109,671	-4.58%

Career and Technical Education Instructional Staff Support includes activities primarily for assisting instructional staff in planning, developing, and evaluating the process of providing learning experiences that give students the opportunity to develop the knowledge, skills and attitudes needed for employment in an occupational area. These activities include curriculum development, techniques of instruction, child development and understanding, and staff training.

Total	Personnel Related	\$ 21,644,602	\$ 22,392,419	\$24,472,581	\$24,628,257
Total	Non-Personnel Related	\$ 6,102,902	\$ 5,881,011	\$ 7,254,170	\$ 6,812,661
Total		\$ 27,747,504	\$ 28,273,430	\$31,726,752	\$31,440,919
		\$ 300,865	\$ 299,846	\$ (2,520,573)	

HICKMAN COUNTY SCHOOLS
FY 2020-21 BUDGET WORKSHEET
as of April 6, 2020

Program Object	Description	FY 2018 Expenditures	FY 2019 Expenditures	FY 2020 Budget	FY 2021 Budget	% Inc/Dec
72250	Technology					
72250 105	Supervisor	\$ 84,634	\$ 56,490	\$ 60,000	\$ 63,000	5.00%
72250 189	Other Salaries & Wages	\$ 6,290	\$ 16,373	\$ 10,120	\$ 7,000	-30.83%
72250 201	Social Security	\$ 11,055	\$ 9,759	\$ 5,364	\$ 5,355	-0.17%
72250 204	State Retirement	\$ 13,400	\$ 7,900	\$ 7,665	\$ 9,646	25.85%
72250 207	Medical Insurance	\$ 1,096	\$ 2,879	\$ 5,000	\$ 5,000	0.00%
72250 336	Maintenance And Repair Services-Equipment	\$ 840	\$ 1,260	\$ 2,000	\$ 2,000	0.00%
72250 355	Travel	\$ 83,398	\$ 88,380	\$ 140,000	\$ 140,000	0.00%
72250 399	Other Contracted Services		\$ 2,082	\$ 2,000	\$ 2,000	0.00%
72250 499	Other Supplies And Materials	\$ 29,246	\$ 25,458	\$ 35,000	\$ 85,000	142.86%
72250 722	Regular Instruction Equipment	\$ 115,379	\$ 95,886	\$ 91,049	\$ 92,901	2.03%
Total	Personnel Related	\$ 114,580	\$ 120,058	\$ 184,000	\$ 234,000	27.17%
Total	Non-Personnel Related	\$ 229,959	\$ 215,944	\$ 275,049	\$ 326,901	18.85%
72250	Technology					

Technology Support includes all expenditures related to the infrastructure and support services for the use of technology district wide.

72250-399

BGC Contract - \$45,000
Monitoring License
ENA

72250-722

\$35,000 Technology equipment
\$50,000 eRate purchase

Total	Personnel Related	\$ 21,644,602	\$ 22,392,419	\$24,472,581	\$24,628,257
Total	Non-Personnel Related	\$ 6,102,902	\$ 5,881,011	\$ 7,254,170	\$ 6,812,661
Total		\$ 27,747,504	\$ 28,273,430	\$31,726,752	\$31,440,919
		\$ 300,865	\$ 299,846	\$ (2,520,573)	

HICKMAN COUNTY SCHOOLS
FY 2020-21 BUDGET WORKSHEET
as of April 6, 2020

Program Object	Description	FY 2018 Expenditures	FY 2019 Expenditures	FY 2020 Budget	FY 2021 Budget	% Inc/Dec
72310	Board Of Education					
72310 191	Board And Committee Members Fees	\$ 5,358	\$ 9,502	\$ 13,000	\$ 13,000	0.00%
72310 196	In-Service Training	\$ 3,010	\$ 6,269	\$ 12,000	\$ 12,000	0.00%
72310 201	Social Security	\$ 377	\$ 673	\$ 1,000	\$ 1,000	0.00%
72310 305	Audit Services	\$ 25,000	\$ 25,750	\$ 35,000	\$ 35,000	0.00%
72310 320	Dues And Memberships	\$ 18,350	\$ 33,551	\$ 32,000	\$ 32,000	0.00%
72310 322	Evaluation And Testing					
72310 331	Legal Services	\$ 33,041	\$ 32,167	\$ 40,000	\$ 40,000	0.00%
72310 399	Other Contracted Services					
72310 505	Judgements					
72310 506	Liability Insurance	\$ 77,779	\$ 58,980	\$ 150,000	\$ 150,000	0.00%
72310 510	Trustee's Commission	\$ 116,794	\$ 119,845	\$ 125,000	\$ 125,000	0.00%
72310 513	Workman's Compensation Insurance	\$ 195,177	\$ 181,359	\$ 250,000	\$ 250,000	0.00%
72310 534	Refund To Applicant For Criminal Investigation		\$ -	\$ 2,000	\$ 1,000	-50.00%
72310 599	Other Charges	\$ 4,850	\$ 4,748	\$ 10,000	\$ 10,000	0.00%
Total	Personnel Related	\$ 8,745	\$ 16,444	\$ 26,000	\$ 26,000	0.00%
Total	Non-Personnel Related	\$ 470,991	\$ 456,399	\$ 644,000	\$ 643,000	-0.16%
72310 Total	Board Of Education	\$ 479,736	\$ 472,843	\$ 670,000	\$ 669,000	-0.15%

Board of Education includes activities of the elected body that have been created according to State law and vested with responsibilities for educational activities in a given administrative

Total	Personnel Related	\$ 21,644,602	\$ 22,392,419	\$24,472,581	\$24,628,257
Total	Non-Personnel Related	\$ 6,102,902	\$ 5,881,011	\$ 7,254,170	\$ 6,812,661
Total		\$ 27,747,504	\$ 28,273,430	\$31,726,752	\$31,440,919
		\$ 300,865	\$ 299,846	\$ (2,520,573)	

HICKMAN COUNTY SCHOOLS
FY 2020-21 BUDGET WORKSHEET
as of April 6, 2020

Program Object	Description	FY 2018 Expenditures	FY 2019 Expenditures	FY 2020 Budget	FY 2021 Budget	% Inc/Dec
72320	Director Of Schools					
72320 101	County Official/Administrative Officer	\$ 100,000	\$ 105,000	\$ 109,000	\$ 109,000	0.00%
72320 117	Career Ladder Program			\$ 1,000	\$ 1,000	0.00%
72320 161	Secretary(s)	\$ 80,944	\$ 84,455	\$ 88,000	\$ 88,000	0.00%
72320 188	Bonus Payments					
72320 189	Other Salaries & Wages	\$ 13,688	\$ 14,270	\$ 15,147	\$ 15,147	0.00%
72320 201	Social Security	\$ 20,325	\$ 20,605	\$ 23,632	\$ 23,423	-0.88%
72320 204	State Retirement	\$ 11,900	\$ 11,900	\$ 11,900	\$ 11,900	0.00%
72320 207	Medical Insurance	\$ 397	\$ 316	\$ 3,000	\$ 3,000	0.00%
72320 307	Communication	\$ 15,336	\$ 12,692	\$ 15,000	\$ 15,000	0.00%
72320 336	Maintenance And Repair Services-Equipment			\$ 2,000	\$ 2,000	0.00%
72320 348	Postal Charges			\$ 4,000	\$ 4,000	0.00%
72320 355	Travel	\$ 2,089	\$ 3,229	\$ 2,500	\$ 2,500	0.00%
72320 399	Other Contracted Services	\$ 2,661	\$ 4,670	\$ 2,500	\$ 2,500	0.00%
72320 435	Office Supplies	\$ 518	\$ 3,233	\$ 2,500	\$ 2,500	0.00%
72320 499	Other Supplies And Materials	\$ 3,644	\$ 2,100	\$ 4,500	\$ 4,500	0.00%
72320 599			\$ 21,999	\$ 21,000	\$ 21,000	-100.00%
Total	Personnel Related	\$ 226,856	\$ 236,230	\$ 248,679	\$ 248,470	-0.08%
Total	Non-Personnel Related	\$ 24,646	\$ 48,239	\$ 54,500	\$ 33,500	-38.53%
Total	Director Of Schools	\$ 251,503	\$ 284,469	\$ 303,179	\$ 281,970	-7.00%

The Office of the Director of Schools includes activities performed in directing and managing all programs of the LEA

Total	Personnel Related	\$ 21,644,602	\$ 22,392,419	\$ 24,472,581	\$ 24,628,257
Total	Non-Personnel Related	\$ 6,102,902	\$ 5,881,011	\$ 7,254,170	\$ 6,812,661
Total		\$ 27,747,504	\$ 28,273,430	\$ 31,726,752	\$ 31,440,919
		\$ 300,865	\$ 299,846	\$ (2,520,573)	

HICKMAN COUNTY SCHOOLS
FY 2020-21 BUDGET WORKSHEET
as of April 6, 2020

Program Object	Description	FY 2018 Expenditures	FY 2019 Expenditures	FY 2020 Budget	FY 2021 Budget	% Inc/Dec
72410	Office Of The Principal					
72410 104	Principals	\$ 617,164	\$ 612,772	\$ 704,000	\$ 704,000	0.00%
72410 139	Assistant Principals	\$ 411,597	\$ 441,663	\$ 493,365	\$ 485,000	-1.70%
72410 201	Social Security	\$ 77,316	\$ 78,207	\$ 91,598	\$ 90,959	-0.70%
72410 204	State Retirement	\$ 93,411	\$ 98,160	\$ 127,280	\$ 122,110	-4.06%
72410 207	Medical Insurance	\$ 90,616	\$ 113,930	\$ 126,000	\$ 126,000	0.00%
72410 348	Postal Charges	\$ 870	\$ 840	\$ 1,600	\$ 1,600	0.00%
72410 355	Travel	\$ 62,136	\$ 2,127	\$ 3,000	\$ 3,600	20.00%
72410 399	Other Contracted Services	\$ 499	\$ 100,000	\$ 160,000	\$ 160,000	0.00%
72410 790	Other Equipment	\$ -	\$ -	\$ -	\$ -	
Total	Personnel Related	\$ 1,290,105	\$ 1,344,732	\$ 1,542,243	\$ 1,528,069	-0.92%
Total	Non-Personnel Related	\$ 63,505	\$ 102,967	\$ 164,600	\$ 165,200	0.36%
Total	Office Of The Principal	\$ 1,353,610	\$ 1,447,699	\$ 1,706,843	\$ 1,693,269	-0.80%

Office of the Principal includes activities concerned with directing and managing the operation of a particular school. Such activities include those performed by the principal, assistant principals, and other assistants while they supervise all operations of the school, evaluate staff, assign duties to staff, supervise and maintain the records of the school, and coordinate school instructional activities with those of the total school system. These activities also include the work of

- 72410-399
- \$12.5k per school
- \$60k for athletic trainer

Total	Personnel Related	\$ 21,644,602	\$ 22,392,419	\$24,472,581	\$24,628,257
Total	Non-Personnel Related	\$ 6,102,902	\$ 5,881,011	\$ 7,254,170	\$ 6,812,661
Total		\$ 27,747,504	\$ 28,273,430	\$31,726,752	\$31,440,919
		\$ 300,865	\$ 299,846	\$ (2,520,573)	

**HICKMAN COUNTY SCHOOLS
FY 2020-21 BUDGET WORKSHEET
as of April 6, 2020**

Program Object	Description	FY 2018 Expenditures	FY 2019 Expenditures	FY 2020 Budget	FY 2021 Budget	% Inc/Dec
72510	Fiscal Services					
72510 105	Supervisor/Director	\$ 66,073				
72510 201	Social Security	\$ 4,758				
72510 204	State Retirement	\$ 6,545				
72510 207	Medical Insurance	\$ 3,400				
72510 399	Other Contracted Services	\$ 1,119	\$ 1,047	\$ 45,000	\$ 45,000	0.00%
Total	Personnel Related	\$ 80,776	\$ -	\$ -	\$ -	
Total	Non-Personnel Related	\$ 81,895	\$ 1,047	\$ 45,000	\$ 45,000	0.00%
72510 Total	Fiscal Services	\$ 81,895	\$ 1,047	\$ 45,000	\$ 45,000	0.00%

Fiscal Services includes activities concerned with the fiscal or financial operations of the LEA. This program includes all aspects of budgeting and financial reporting (such as receipts and disbursements, financial and property accounting, payroll, inventory control, internal auditing and the managing of funds).

•72510-399 - Includes \$42,000 for Finance Office Services

Total	Personnel Related	\$ 21,644,602	\$ 22,392,419	\$24,472,581	\$24,628,257
Total	Non-Personnel Related	\$ 6,102,902	\$ 5,881,011	\$ 7,254,170	\$ 6,812,661
Total		\$ 27,747,504	\$ 28,273,430	\$31,726,752	\$31,440,919
		\$ 300,865	\$ 299,846	\$ (2,520,573)	

HICKMAN COUNTY SCHOOLS
FY 2020-21 BUDGET WORKSHEET
as of April 6, 2020

Program Object	Description	FY 2018 Expenditures	FY 2019 Expenditures	FY 2020 Budget	FY 2021 Budget	% Inc/Dec
72610	Operation Of Plant					
72610 307	Communication	\$ 44,711	\$ 52,470	\$ 60,000	\$ 50,000	-16.67%
72610 399	Other Contracted Services	\$ 560,034	\$ 571,786	\$ 650,000	\$ 700,000	7.69%
72610 410	Custodial Supplies	\$ 21,737	\$ 28,892	\$ 30,000	\$ 35,000	16.67%
72610 415	Electricity	\$ 847,553	\$ 847,044	\$ 915,000	\$ 915,000	0.00%
72610 434	Natural Gas	\$ 102,453	\$ 118,136	\$ 125,000	\$ 125,000	0.00%
72610 454	Water And Sewer	\$ 195,060	\$ 212,553	\$ 250,000	\$ 245,000	-2.00%
72610 499	Other Supplies And Materials	\$ 1,712	\$ 489	\$ 3,000	\$ 3,000	0.00%
72610 501	Boiler Insurance	\$ 2,395	\$ 4,825	\$ 8,000	\$ 8,000	0.00%
72610 502	Building And Contents Insurance	\$ 139,350	\$ 143,520	\$ 177,000	\$ 180,000	1.69%
72610 720	Plant Operation Equipment	\$ 3,934	\$ 5,000	\$ 95,000	\$ 85,000	-10.53%
Total	Non-Personnel Related	\$ 1,918,940	\$ 1,984,714	\$ 2,313,000	\$ 2,346,000	1.43%
72610	Operation Of Plant	\$ 1,918,940	\$ 1,984,714	\$ 2,313,000	\$ 2,346,000	1.43%

Operation of Plant includes activities concerned with keeping the physical plant clean and ready for daily use. These activities include operating the heating, lighting, and ventilating systems, and repairing and replacing equipment (vacuum cleaners, buffers, etc.).

- 72610-399 Includes increase for everyday cleaning
- 72610-720 Gym HVAC units at EHMS/EHES

Total	Personnel Related	\$ 21,644,602	\$ 22,392,419	\$24,472,581	\$24,628,257
Total	Non-Personnel Related	\$ 6,102,902	\$ 5,881,011	\$ 7,254,170	\$ 6,812,661
Total		\$ 27,747,504	\$ 28,273,430	\$31,726,752	\$31,440,919
		\$ 300,865	\$ 299,846	\$ (2,520,573)	

HICKMAN COUNTY SCHOOLS
FY 2020-21 BUDGET WORKSHEET
as of April 6, 2020

Program Object	Description	FY 2018 Expenditures	FY 2019 Expenditures	FY 2020 Budget	FY 2021 Budget	% Inc/Dec
72620	Maintenance Of Plant					
72620 105	Supervisor/Director	\$ 60,843	\$ 60,350	\$ 63,000	\$ 63,000	0.00%
72620 161	Secretary(s)	\$ 9,947	\$ 10,205	\$ 11,900	\$ 11,000	-7.56%
72620 189	Other Salaries & Wages	\$ 146,176	\$ 155,049	\$ 165,200	\$ 168,669	2.10%
72620 201	Social Security	\$ 14,713	\$ 15,067	\$ 19,124	\$ 19,329	1.07%
72620 204	State Retirement	\$ 29,898	\$ 29,160	\$ 33,086	\$ 33,440	1.07%
72620 207	Medical Insurance	\$ 40,000	\$ 19,800	\$ 35,000	\$ 35,000	0.00%
72620 335	Maintenance And Repair Services-Buildings	\$ 200,357	\$ 228,981	\$ 200,000	\$ 200,000	0.00%
72620 336	Maintenance And Repair Services-Equipment	\$ 232,180	\$ 249,921	\$ 225,000	\$ 225,000	0.00%
72620 355	Travel	\$ 2,881	\$ 3,625	\$ 6,000	\$ 5,000	-16.67%
72620 399	Other Contracted Services	\$ 60,588	\$ 66,212	\$ 182,000	\$ 182,000	0.00%
72620 418	Equipment And Machinery Parts		\$ 7,498	\$ 9,000	\$ 9,000	0.00%
72620 425	Gasoline		\$ -		\$ 1,000	
72620 499	Other Supplies And Materials	\$ 32	\$ 2,405	\$ 16,883		-100.00%
72620 701	Administration Equipment		\$ 95,057	\$ 121,000		-100.00%
72620 707	Building Improvements	\$ 15,063	\$ 29,184	\$ 27,000		-100.00%
72620 717	Maintenance Equipment		\$ 54,188			
Total	Personnel Related	\$ 301,577	\$ 289,630	\$ 327,310	\$ 330,438	0.96%
Total	Non-Personnel Related	\$ 511,301	\$ 737,070	\$ 786,883	\$ 622,000	-20.95%
72620 Total	Maintenance Of Plant	\$ 812,878	\$ 1,026,700	\$ 1,114,193	\$ 952,438	-14.52%

Maintenance of Plant includes activities concerned with keeping the physical plant open, comfortable, and safe for use, and keeping the grounds, buildings, and equipment in effective working condition and state of repair.

72620-399 Includes following:

- \$59k mowing
- \$23k HVAC
- \$20k gym floor resealing
- \$22k fire alarm contract
- \$7k sprinkler contract
- \$3k generator contract
- \$3k elevator contract

Total	Personnel Related	\$ 21,644,602	\$ 22,392,419	\$24,472,581	\$24,628,257
Total	Non-Personnel Related	\$ 6,102,902	\$ 5,881,011	\$ 7,254,170	\$ 6,812,661
Total		\$ 27,747,504	\$ 28,273,430	\$31,726,752	\$31,440,919
		\$ 300,865	\$ 299,846	\$ (2,520,573)	

HICKMAN COUNTY SCHOOLS
FY 2020-21 BUDGET WORKSHEET
as of April 6, 2020

Program Object	Description	FY 2018 Expenditures	FY 2019 Expenditures	FY 2020 Budget	FY 2021 Budget	% Inc/Dec
72710	Transportation					
72710 105	Supervisor/Director	\$ 57,435	\$ 52,310	\$ 56,000	\$ 60,000	7.14%
72710 142	Mechanic(s)	\$ 73,091	\$ 78,224	\$ 91,100	\$ 92,630	1.68%
72710 146	Bus Drivers	\$ 592,713	\$ 626,003	\$ 665,960	\$ 681,070	2.27%
72710 161	Secretary(s)	\$ 9,947	\$ 10,205	\$ 11,800	\$ 11,000	-6.78%
72710 201	Social Security	\$ 54,094	\$ 56,685	\$ 63,102	\$ 64,620	2.41%
72710 204	State Retirement	\$ 99,617	\$ 100,620	\$ 113,666	\$ 116,400	2.41%
72710 207	Medical Insurance	\$ 93,000	\$ 114,844	\$ 116,000	\$ 126,000	8.62%
72710 299	Other Fringe Benefits	\$ 8,276	\$ 19,229	\$ 53,000	\$ 43,000	-18.87%
72710 338	Maintenance And Repair Services-Vehicles	\$ 65	\$ 370	\$ 25,000	\$ 25,000	0.00%
72710 355	Travel	\$ 1,702	\$ 1,961	\$ 2,500	\$ 2,500	0.00%
72710 399	Other Contracted Services	\$ 52,929	\$ 30,222	\$ 52,500	\$ 52,500	0.00%
72710 412	Diesel Fuel	\$ 150,418	\$ 170,470	\$ 234,000	\$ 235,000	0.43%
72710 418	Equipment And Machinery Parts		\$ 682	\$ 1,800	\$ 1,800	0.00%
72710 424	Garage Supplies	\$ 496	\$ 2,955	\$ 3,150	\$ 3,150	0.00%
72710 425	Gasoline	\$ 16,587	\$ 20,905	\$ 30,000	\$ 30,000	0.00%
72710 433	Lubricants	\$ 1,850	\$ 5,050	\$ 12,000	\$ 12,000	0.00%
72710 450	Tires And Tubes	\$ 17,837	\$ 22,570	\$ 30,000	\$ 30,000	0.00%
72710 453	Vehicle Parts	\$ 49,928	\$ 73,823	\$ 100,000	\$ 100,000	0.00%
72710 511	Vehicle And Equipment Insurance	\$ 22,518	\$ 40,158	\$ 45,000	\$ 45,000	0.00%
72710 524	Inservice	\$ 250		\$ 500	\$ 500	0.00%
72710 720	Plant Operation Equipment		\$ 26,599			
72710 729	Transportation Equipment	\$ 352,567	\$ 392,688	\$ 769,686	\$ 600,000	-22.05%
Total	Personnel Related	\$ 988,172	\$ 1,058,119	\$ 1,170,627	\$ 1,194,720	2.06%
Total	Non-Personnel Related	\$ 667,147	\$ 788,454	\$ 1,306,136	\$ 1,137,450	-12.91%
72710 Total	Transportation	\$ 1,655,319	\$ 1,846,573	\$ 2,476,763	\$ 2,332,170	-5.84%

Transportation includes activities concerned with conveying students for Regular, Vocational, and Special Educational instruction, as provided by State and Federal law. This includes trips between home and school, and trips to school activities. Transportation includes operation expenses for system-owned vehicles involved in the transportation function. Vehicle servicing, maintenance, and contracts for transporting services should also be recorded in this category.

*72710-729 6 Buses with Seatbelts - \$300,000 will be reimbursed from grant

Total	Personnel Related	\$ 21,644,602	\$ 22,392,419	\$24,472,581	\$24,628,257
Total	Non-Personnel Related	\$ 6,102,902	\$ 5,881,011	\$ 7,254,170	\$ 6,812,661
Total		\$ 27,747,504	\$ 28,273,430	\$31,726,752	\$31,440,919
		\$ 300,865	\$ 299,846	\$ (2,520,573)	

**HICKMAN COUNTY SCHOOLS
FY 2020-21 BUDGET WORKSHEET
as of April 6, 2020**

Program Object	Description	FY 2018 Expenditures	FY 2019 Expenditures	FY 2020 Budget	FY 2021 Budget	% Inc/Dec
72810	Central And Other					
72810 188	Bonus Payments	\$ -	\$ -	\$ 2,000	\$ 1,000	-50.00%
72810 201	Social Security	\$ 1,293	\$ 47			
72810 207	Medical Insurance					
72810 210	Unemployment Compensation	\$ 6,115	\$ 6,449	\$ 35,000	\$ 35,000	0.00%
72810 299	Other Fringe Benefits	\$ 17,840	\$ 728	\$ 5,000	\$ 5,000	0.00%
72810 316	Contributions	\$ 155,775	\$ 172,587	\$ 152,500	\$ 152,500	0.00%
72810 399	Other Contracted Services	\$ 20,615	\$ 27,306	\$ 30,000	\$ 30,000	0.00%
72810 499	Other Supplies And Materials	\$ 22,156	\$ 13,374	\$ 30,000	\$ 30,000	0.00%
72810 599	Other Charges	\$ -	\$ 4,000			
Total	Personnel Related	\$ 25,249	\$ 7,224	\$ 42,000	\$ 41,000	-2.38%
Total	Non-Personnel Related	\$ 198,546	\$ 217,267	\$ 212,500	\$ 212,500	0.00%
72810 Total	Central And Other	\$ 223,795	\$ 224,491	\$ 254,500	\$ 253,500	-0.39%

Activities concerned with maintaining an efficient staff for the LEA. It includes such activities in the Personnel Dept. such as recruiting and placement, staff transfers, in-service training, health services for staff, and data processing services for maintaining personnel records.

•72810-316 SRO's

Total	Personnel Related	\$ 21,644,602	\$ 22,392,419	\$24,472,581	\$24,628,257
Total	Non-Personnel Related	\$ 6,102,902	\$ 5,881,011	\$ 7,254,170	\$ 6,812,661
Total		\$ 27,747,504	\$ 28,273,430	\$31,726,752	\$31,440,919
		\$ 300,865	\$ 299,846	\$ (2,520,573)	

**HICKMAN COUNTY SCHOOLS
FY 2020-21 BUDGET WORKSHEET
as of April 6, 2020**

Program Object	Description	FY 2018 Expenditures	FY 2019 Expenditures	FY 2020 Budget	FY 2021 Budget	% Inc/Dec
73100	Food Service					
73100 105	Supervisor/Director	\$ 22,880	\$ 22,880	\$ 23,800	\$ 23,800	0.00%
73100 201	Social Security	\$ 1,750	\$ 1,720	\$ 1,821	\$ 1,821	0.00%
73100 204	State Retirement			\$ 2,489	\$ 2,489	0.00%
73100 355	Travel					
73100 524	Inservice					
Total	Personnel Related	\$ 24,630	\$ 24,600	\$ 28,110	\$ 28,110	0.00%
Total	Non-Personnel Related	\$ -	\$ -	\$ -	\$ -	0.00%
Total	Food Service	\$ 24,630	\$ 24,600	\$ 28,110	\$ 28,110	0.00%

School Nutrition includes activities concerned with providing meals to students and staff in a school or school system. This service area includes the supervision of a staff whose responsibility is to prepare and serve regular and incidental meals, lunches, or snacks in connection with school activities and food

Total	Personnel Related	\$ 21,644,602	\$ 22,392,419	\$24,472,581	\$24,628,257
Total	Non-Personnel Related	\$ 6,102,902	\$ 5,881,011	\$ 7,254,170	\$ 6,812,661
Total		\$ 27,747,504	\$ 28,273,430	\$31,726,752	\$31,440,919
		\$ 300,865	\$ 299,846	\$ (2,520,573)	

HICKMAN COUNTY SCHOOLS
FY 2020-21 BUDGET WORKSHEET
as of April 6, 2020

Program Object	Description	FY 2018 Expenditures	FY 2019 Expenditures	FY 2020 Budget	FY 2021 Budget	% Inc/Dec
73300	Community Services					
73300 105	Supervisor/Director	\$ 29,267	\$ 30,176	\$ 31,500	\$ 31,500	0.00%
73300 189	Other Salaries & Wages	\$ 53,388	\$ 53,515	\$ 56,662	\$ 56,802	0.25%
73300 201	Social Security	\$ 6,107	\$ 6,337	\$ 6,744	\$ 6,755	0.16%
73300 204	State Retirement	\$ 11,046	\$ 11,169	\$ 12,149	\$ 12,168	0.16%
73300 207	Medical Insurance	\$ 7,438	\$ 11,422	\$ 18,000	\$ 18,000	0.00%
73300 355	Travel					
73300 399	Other Contracted Services					
73300 499	Other Supplies And Materials	\$ 4,999	\$ 5,000	\$ 5,000	\$ 5,000	0.00%
73300 524	Inservice		\$ 110	\$ 250	\$ 250	0.00%
73300 599	Other Charges		\$ -		\$ 2,000	
Total	Personnel Related	\$ 107,246	\$ 112,619	\$ 125,055	\$ 125,055	0.00%
Total	Non-Personnel Related	\$ 4,999	\$ 5,110	\$ 5,250	\$ 5,250	0.00%
73300 Total	Community Services	\$ 112,245	\$ 117,729	\$ 130,305	\$ 130,305	0.00%

Community Services includes activities concerned with providing community services to students, staff or community participants. This includes expenditures for system staff participating in community organizations such as leadership, family resource centers, Families First, Pre-K programs, extended school

Total	Personnel Related	\$ 21,644,602	\$ 22,392,419	\$24,472,581	\$24,628,257
Total	Non-Personnel Related	\$ 6,102,902	\$ 5,881,011	\$ 7,254,170	\$ 6,812,661
Total		\$ 27,747,504	\$ 28,273,430	\$31,726,752	\$31,440,919
		\$ 300,865	\$ 299,846	\$ (2,520,573)	

HICKMAN COUNTY SCHOOLS
FY 2020-21 BUDGET WORKSHEET
as of April 6, 2020

Program Object	Description	FY 2018 Expenditures	FY 2019 Expenditures	FY 2020 Budget	FY 2021 Budget	% Inc/Dec
73400	Early Childhood Education					
73400 105	Supervisor/Director	\$ 36,588	\$ 36,609	\$ 38,325	\$ 39,820	3.90%
73400 116	Teachers	\$ 172,700	\$ 174,047	\$ 177,100	\$ 190,700	7.68%
73400 163	Educational Assistants	\$ 64,913	\$ 45,591	\$ 69,200	\$ 69,200	0.00%
188				\$ 9,250		-100.00%
73400 189	Other Salaries & Wages	\$ 32,046	\$ 10,713	\$ 12,000	\$ 12,000	0.00%
73400 198	Non-Certified Substitute Teachers	\$ 4,000	\$ -	\$ 5,000	\$ 5,000	0.00%
73400 201	Social Security	\$ 22,771	\$ 19,855	\$ 23,782	\$ 24,229	1.88%
73400 204	State Retirement	\$ 32,173	\$ 36,036	\$ 37,036	\$ 35,553	-4.00%
73400 207	Medical Insurance	\$ 41,850	\$ 45,450	\$ 48,000	\$ 48,000	0.00%
73400 210	Unemployment Compensation					
73400 355	Travel		\$ 126	\$ 500	\$ 500	0.00%
73400 399	Other Contracted Services	\$ 395	\$ 560	\$ 2,000	\$ 2,000	0.00%
73400 422	Food Supplies					
73400 429	Instructional Supplies And Materials	\$ 24,221	\$ 15,464	\$ 10,500	\$ 10,500	0.00%
73400 499	Other Supplies And Materials	\$ 10,445	\$ 9,059	\$ 10,500	\$ 10,500	0.00%
73400 524	Inservice		\$ 976	\$ 1,161	\$ 1,161	0.00%
73400 790	Other Equipment	\$ 1,924	\$ 4,991	\$ 4,000	\$ 4,000	0.00%
Total	Personnel Related	\$ 407,040	\$ 368,302	\$ 419,693	\$ 424,502	1.15%
Total	Non-Personnel Related	\$ 36,985	\$ 31,176	\$ 28,661	\$ 28,661	0.00%
Total	Early Childhood Education	\$ 444,025	\$ 399,478	\$ 448,354	\$ 453,163	1.07%

Voluntary Pre-K - Funding level for fy 2019-20 has not been determined yet.

Total	Personnel Related	\$ 21,644,602	\$ 22,392,419	\$ 24,472,581	\$ 24,628,257
Total	Non-Personnel Related	\$ 6,102,902	\$ 5,881,011	\$ 7,254,170	\$ 6,812,661
Total		\$ 27,747,504	\$ 28,273,430	\$ 31,726,752	\$ 31,440,919
		\$ 300,865	\$ 299,846	\$ (2,520,573)	

**HICKMAN COUNTY SCHOOLS
FY 2020-21 BUDGET WORKSHEET
as of April 6, 2020**

Program Object	Description	FY 2018 Expenditures	FY 2019 Expenditures	FY 2020 Budget	FY 2021 Budget	% Inc/Dec
76100 799	Other Capital Outlay	\$ 861,077	\$ 294,814	\$ 331,000	\$ 105,000	-68.28%

\$25k - ADA Compliance
\$80k - EHHS Parking Lot Curtain Drains

Total	Personnel Related	\$ 21,644,602	\$ 22,392,419	\$ 24,472,581	\$ 24,628,257
Total	Non-Personnel Related	\$ 6,102,902	\$ 5,881,011	\$ 7,254,170	\$ 6,812,661
Total		\$ 27,747,504	\$ 28,273,430	\$ 31,726,752	\$ 31,440,919
		\$ 300,865	\$ 299,846	\$ (2,520,573)	

**HICKMAN COUNTY SCHOOLS
FY 2020-21 BUDGET WORKSHEET
as of April 6, 2020**

Program Object	Description	FY 2018	FY 2019	FY 2020	FY 2021	
		Expenditures	Expenditures	Budget	Budget	% Inc/Dec
99100	590 Transfers To Other Funds	\$ 136,070	\$ 163,284	\$ 165,000	\$ 165,000	0.00%

Click here to choose a school board.			
Monitoring: Review: Annually, in August	Descriptor Term: Emergency Closings	Descriptor Code: 1.8011	Issued Date:
		Rescinds:	Issued:

Add

General

The Board authorizes the Director of Schools to close schools in the event of hazardous weather, a public health emergency, or any other emergency which presents a threat to the safety of students, staff members, or school property.¹

As soon as the decision to close schools is made, the Director of Schools will notify the public media and request that an announcement be made.

If school is not in session or is dismissed early due to snow or inclement weather, the Director of Schools in consultation with the principal(s) of the impacted school(s) shall determine if all scheduled activities in which students are involved shall be postponed or cancelled.

EMPLOYEE RESPONSIBILITIES

In the event of an emergency that requires closure of a school building, group of schools, or the entire district, the Director of Schools is authorized to continue to pay employees who are not able to physically report for duty as a result. These employees shall receive their regular wages. Such payments shall not exceed the number of days budgeted for each employee.

During such emergencies, the Director of Schools may designate certain employees as essential. Such employees shall work as directed by the Director of Schools, whether that is by physical appearance at work or teleworking under Policy 5.1151. Essential employees must use leave to be excused from work absent special permission as determined by the Director of Schools/designee.

add to current policy

Legal References

1. TCA 49-6-3004(e)(1); TRR/MS 0520-01-03-.02(1)(b)

Cross References

- Emergency Preparedness Plan 3.202
Telework During Emergencies 5.1151

New policy

Click here to choose a school board.

Monitoring: Review: Annually, in January	Descriptor Term: Telework During Emergencies	Descriptor Code: 5.1151	Issued Date:
		Rescinds:	Issued:

General

Teleworking is a work arrangement where designated employees are allowed to perform their normal duties and responsibilities through the use of hardware and software at an alternate location from their normal work site.

The Director of Schools may require an employee to telework if the duties and responsibilities of the position are required during times of emergency. An employee's participation in the program will be determined by the length and duration of the emergency and will be both initiated and ended at the discretion of the supervisor and/or the Director of Schools.

WORK ENVIRONMENT

Employees approved for telework shall maintain a dedicated and safe work environment.

An employee who teleworks shall not allow anyone other than district employees to utilize district provided services or equipment. Employees shall keep remote work and information confidential, in accordance with district policies, procedures, and applicable privacy laws.

Cross References

Emergency Closings 1.8011

New policy

Click here to choose a school board.			
Monitoring: Review: Annually, in January	Descriptor Term: FFCRA LEAVE	Descriptor Code: 5.3051	Issued Date: Click here to enter a date.
		Rescinds:	Issued:

General¹

Under the Families First Coronavirus Response Act (FFCRA), this policy will be in effect from April 1, 2020 until December 31, 2020.

The Director of Schools/designee shall post notice of FFCRA requirements and create any necessary administrative procedures. Employees should seek clarification from [insert title of employee] if they have questions regarding the total amount of leave and pay available to them.

PAID SICK LEAVE

Employees are entitled to up to two (2) weeks of paid sick leave if they are unable to work or telework because the employee:²

1. is subject to a Federal, State, or local quarantine or isolation order related to COVID-19;
2. has been advised by a health care provider to self-quarantine related to COVID-19;
3. is experiencing COVID-19 symptoms and is seeking a medical diagnosis;
4. is caring for an individual subject to or advised to quarantine or isolate due to COVID-19. The individual must be someone with a personal relationship to the employee;
5. is caring for his/her son or daughter whose school or place of care is closed, or person who regularly provides child care is unavailable, for reasons related to COVID-19 and no other suitable person is available to care for the child during the requested period of leave. Son or daughter is defined as a biological, adopted, or foster child, a stepchild, a legal ward, or a child of a person standing *in loco parentis*, who is under 18 years of age; or 18 years of age or older who is incapable of self-care because of a mental or physical disability; or
6. is experiencing any other substantially similar condition specified by the Secretary of Health and Human Services, in consultation with the Secretaries of Labor and Treasury.

This paid leave may be taken if there is work available for the employee to complete and the employee is unable to work or telework for one of the above reasons. Such leave is in addition to any paid leave that an employee may already be entitled to (e.g. existing sick leave). Employees are not required to exhaust any other paid leave benefit in order to utilize this new category of paid sick leave.

EXPANDED FMLA LEAVE

Full-time or part-time employees who have been on the payroll for thirty (30) calendar days prior to the beginning of the leave are eligible for expanded FMLA leave (EFMLEA). This includes employees who were laid off or terminated after March 1, 2020, who had worked for the district for at least thirty (30) of the prior sixty (60) calendar days and were subsequently rehired or otherwise employed by the district.³

Under the FFCRA, an employee qualifies for EFMLEA leave if the employee is unable to work or telework due the need to care for his/her son or daughter because of a school or child care facility closure or because the person who regularly provides child care (i.e. this could include a family member or a neighbor) is unavailable for reasons related to COVID-19.⁴ In these circumstances, a son or daughter is defined as a biological, adopted, or foster child, a stepchild, a legal ward, or a child of a person standing *in loco parentis*, who is under 18 years of age; or 18 years of age or older who is incapable of self-care because of a mental or physical disability.

Qualifying employees may take twelve (12) weeks of EFMLEA leave.⁵ The amount of leave available may be impacted by any prior use of FMLA.⁶

The first ten (10) days of EFMLEA leave shall be unpaid, however, an employee may choose to take any existing leave benefit during this time. After ten (10) days, EFMLEA leave is paid at two-thirds (2/3) the rate of the employee's regular rate of pay, unless he/she chooses to utilize accrued sick leave or annual leave to cover those days or the amount is capped per federal law.⁷

Legal References

1. Families First Coronavirus Response Act, Pub. L. No. 116-127, §§ 3102, 5101, et seq, (2020)
2. 29 CFR § 826.20(a); 29 CFR § 826.21; 29 CFR § 826.30(a)
3. 29 CFR § 826.30(b); Coronavirus Aid, Relief, and Economic Security Act (CARES Act), § 3605 (2020)
4. 29 CFR § 826.20(b)
5. 29 CFR § 826.23
6. 29 CFR § 826.23(b); 29 CFR § 826.70
7. 29 CFR § 826.24

Cross References

Sick Leave 5.302
Family and Medical Leave 5.305

2019-2020 Grading Procedures
In response to closure from COVID-19

For quarter 4 grades, students will receive one of the following as grades: 1) if grades were recorded before the closure on March 16, teachers can average those grades for Quarter 4 or 2) teachers will review students' previous grades for Quarters 1-3 and use the highest grade for quarter 4.

Teachers should use their best professional judgment in grades K-2 when determining mastery of grade level skills based on the academic performance, benchmark data, class work, and other information obtained by the teacher.

The option that best benefits the student will be entered as Quarter 4 grade. According to the State Board of Education policy, students will receive a final grade no lower than the grade average of Quarters 1 – 3 on March 20th when the State of Emergency was enforced.

Final grades will be calculated in accordance with the guidelines in Hickman County Board of Education policy 4.600 using the average of the two semesters for a final grade.

Students will continue with dual enrollment, dual credit, online, SAILS, etc. classes until the University (or other host) decides otherwise.

Seniors who are currently in danger of not graduating will be contacted and given specific assignments that they must complete in order to be brought back in good standing. Students who are in good standing are eligible to participate in graduation activities and/or receive their diploma.

Promotion/Retention: The State of Emergency will not be the sole criterion for a student to be retained this year. Decisions of promotion/retention will be based on the individual promotion plan of the student and academic performance and conversations which took place prior to schools' closure.

Students with IEPs will receive end-of-year progress reports. Teachers will use students' past performance, most recent data in regards to IEP goals, and professional judgement to complete end of the year progress reports. Parents will have the option of picking up the report or choosing to have it mailed/e-mailed.

April 27, 2020

Dear Members of the Hickman County Board of Education:

Please accept this request for an additional supplemental stipend for the food service employees that have worked for our school nutrition program during the school closure from COVID-19. I would like to request for food service workers to be paid \$50.00 per day worked on-site during the school closure. This will cost the school system a total of \$52,000.00, including the payroll expenses associated with the supplemental pay. The funding for this request would come from the 143 cafeteria fund if available and would be taken from the 141 general fund if not available in the 143 cafeteria fund.

During this school closure, our school nutrition team served breakfast and lunch to between 1,400-1,500 students each day. Their work and dedication made it possible for our school system to meet the physical needs of the children of our community.

Sincerely,

Michelle Gilbert



School Accountability

The Hickman County School system will evaluate the effectiveness and continued viability of the Hickman County Learning Academy each year as fiscal, operational, and academic performance information can be reviewed by district leadership. During the first year of implementation, our plan is to limit enrollment to approximately 40 students so that proper support can be provided to this new type of program. Successful implementation of the initial year will allow for incremental increases in enrollment in subsequent years. Following the completion of the first academic year, the school system will:

- Review the number of students that were successfully able to complete the coursework in this program. Our goal is the majority of students that begin the academic year will be able to finish it successfully. A root-cause analysis will be complete for students that leave the program early to determine if additional program supports are needed for student success.
- Evaluate the amount of time required by staff to successfully administer the virtual program. District leadership will analyze the time allocated by the school coordinator as compared to the administrative duties of the traditional school principals. The school system will evaluate staffing to determine what is sufficient for operational needs.
- Analyze student achievement scores as compared to other schools in the district as well as other virtual learning programs. Our district will evaluate the curriculum that has been chosen as compared to the performance of other programs/schools once assessment data has been received from the Tennessee Department of Education.
- Hickman County will collaborate and network with other school systems that offer virtual learning opportunities to analyze and compare programs including course completion, credits earned, and assessment results.
- Fiscal returns will have to be present for the district to have the capability to sustain the program. The school district will forecast fiscal costs annually. The amount of fiscal increase will impact the ability of the school district to add additional positions to support the success of the virtual learning program.
- Families will be surveyed twice during the year during the first year of implementation. The school district will survey the families during the fall semester to obtain baseline data regarding the program. District leadership will analyze the feedback to identify areas of success and areas of challenge. A prioritized list will be developed after the winter break to make modifications for the second semester. An end of year survey will be provided to families to further improve the offerings of the program.



Student Assessment

All students enrolled in the virtual program will be expected to participate in state required assessments such as TCAP, ACT, EOC, etc. The Student and Parent Contract that is reviewed at the in-person orientation will contain state mandated assessment information including all required assessments for each grade level. A district assessment calendar will be provided to families at the in-person orientation. The school coordinator will ensure families are aware of assessment dates, and will work with schools to plan for virtual program students' participation. Students will be required to come onto school campus and complete assessments in accordance with state testing administration guidelines. Assessment personnel that have been trained in the state security guidelines will be allowed to administer assessments to students enrolled in the virtual learning program. All test materials will remain secure in school buildings, just as other test materials are treated. Students will not be allowed to take assessments home. The school coordinator will share results with families.

Students that do not participate in the state assessment on the day it is scheduled will be provided an opportunity to make up the test as is done for traditional students. The school coordinator will contact families that miss assessment days to plan for the makeup opportunity. If a student is absent for the makeup assessment day, the school coordinator will ask for a valid excuse to be provided. If a valid excuse cannot be submitted, the student will receive a grade of "0" for assessments that calculate into a student final grade. The school coordinator will also take this into consideration when reviewing eligibility for continued enrollment in the virtual learning school. Students that do not take two or more assessments without submitting valid excuses will be subject to removal from the virtual learning school.



Student Participation and Progress

To ensure students enrolled in the virtual learning program are on track and making progress in their online coursework, Edgenuity and the school coordinator are committed to the following:

- The school coordinator will clearly convey district expectations for student participation, course completion, academic integrity and independent work completion through an in-person orientation with parents and students prior to the start of school.
- Edgenuity staff will provide an in-person orientation to families with detailed participation and progress expectations prior to the start of school.
- Edgenuity will provide a pacing guide for each course a student is enrolled.
- Edgenuity instructors are committed to a minimum of weekly contact with students. Additional contact will be made with students not submitting assignments according to the pacing guide or when assignments do not meet expectations.
- Edgenuity instructors will monitor pacing guide adherence and address instances of non-compliance with students and parents as well as the school coordinator.
- Edgenuity instructors are committed to a minimum of once a month contact with parents to ensure parents are aware of student progress.
- The School Coordinator will monitor assignment completion through the Edgenuity platform.
- The School Coordinator will closely monitor weekly emails received from online instructors regarding the progress of students and reach out to families as needed.
- The School Coordinator will recommend tutoring lab hours to any students not adhering to the pacing guide or not demonstrating desired skill levels on submitted assignments.
- A progress report in each course will be provided by the Edgenuity instructor to the school coordinator and families at the 4.5 week progress report data as set by the district calendar.
- Grades for report cards will be submitted by Edgenuity to the school coordinator. The school coordinator will submit those grades for official grading period grades and provide report cards to families as set by dates on the district calendar.



School Attendance Expectations

Students enrolled in the Hickman County virtual learning program are expected to adhere to the Tennessee Department of Education requirements for school attendance and length of day. Students enrolled in the Hickman County virtual learning program will follow the district calendar set forth by the Hickman County Board of Education for mandatory instructional days with the exception of adding 2 professional days in the place of stockpile professional development days. While the district allows the stockpiling of instructional time to accumulate 2 professional development days for its traditional schools, the students enrolled in the virtual learning program will have instructional days where the 2 professional development days from stockpile are used. Therefore, the students in the virtual learning program will be expected to attend school for 180 calendar days. Students will be expected to spend 6.5 hours per day involved in instructional activities. The school coordinator will provide a yearly calendar to all enrolled students.

Parents and students will sign a contract to participate in the virtual learning program that explicitly states expectations for attendance. The student and parent contract will be reviewed in an in-person meeting prior to beginning the academic year. Pacing guide adherence will be constantly monitored by district and Edgenuity staff to ensure students are staying on track for academic goals. District staff and Edgenuity instructors will access information within the platform to observe a student's work within course instruction and assignments. District staff as well as Edgenuity staff will address every instance of non-compliance with school attendance expectations. Families will also be expected to document on a district provided calendar days that the student attended class virtually. The calendars will be submitted to the school coordinator at the end of each semester.

A student is identified as being non-compliant with program expectations when the student has three (3) days of unexcused absences from participation in the virtual instructional program or if the student is 3 days or more behind the pacing guide expectation for the course. The following steps will be followed:

1. At the time a student is identified as being non-compliant with school attendance expectations the school coordinator will reach out to the family by phone. This initial conversation will serve as a reminder of contract agreements and attendance requirements to remain eligible for the virtual school program.
2. If the student continues to be non-compliant by not participating in instructional days or remaining 3 or more days behind pacing guide expectations, the school coordinator will develop a written plan to address and remediate attendance issues and make up missed assignments. The student and parent will have 5 days to meet with the school coordinator and sign this plan for remediation.
3. If a student/family does not meet with the school coordinator or if the student continues to be non-compliant with attendance and/or assignment expectations he/she will be dismissed from the virtual learning program.
4. If a student is dismissed from the program, the family will have 5 days to provide evidence of enrollment in a new program or will be subject to the district truancy policy.



Attendance Policy

The Hickman County School System is committed to student achievement, with a vital part of student achievement being satisfactory school attendance. All Hickman County students enrolled in the virtual learning program in Hickman County are expected to be present online and participate in instructional activities every day that is designated as an instructional day with the exception of: student illness, serious illness or death in the immediate family, parent military deployment, summons to appear in court or recognized religious observances. Any other extenuating circumstances will be judged on a case-by-case basis and decided upon by the school coordinator.

Absences should only occur when a valid excuse can be submitted for the absence. All absences will be classified as either excused or unexcused as determined by the school coordinator. Students/parents will have three (3) days to submit the necessary documentation to the school coordinator in order to excuse an absence.

Absences that are unexcused will result in a student being referred for truancy action. A student is truant when 5 unexcused full days absences occur. A student that is considered truant will be referred to the district's tiered intervention process for attendance. Parents and students that do not improve attendance will progress through the three tiers of attendance intervention, including personal meetings with district staff, meetings with truancy council, and eventually petitions filed in juvenile court. Chronic unexcused absences could also result in the Tennessee Department of Safety revoking a student's privilege to hold a driver's license.

Absences will be considered excused if documentation is provided to the school office within 3 days of: student illness, serious illness or death in the immediate family, parent military deployment, summons to appear in court, or recognized religious observances. Schools will accept parent notes to cover up to eight (8) days of absences per year. All documentation submitted for excusing an absence will be reviewed and determined valid or invalid by the school coordinator.



Curriculum Information

The Hickman County School System will provide rigorous, complete online instruction and curriculum to all students enrolled in the virtual learning program. Students will access the Edgenuity platform for online courses that offers a variety of core academic and elective courses. All Edgenuity Tennessee courses are aligned to the Tennessee Department of Education curriculum standards. Courses are available in the core academic areas of language arts, mathematics, social studies, and science. Elective, foreign language, and career technical courses are available to ensure all students access to a wide spectrum of high quality educational experiences.

Once a student is accepted into the virtual learning program, a username and password will be provided to the student and parent. Pacing guides are provided to ensure teachers, students, and school staff can effectively monitor the pacing and progress of all students. Every course provided on the Edgenuity platform will be instructed by certified Tennessee teachers who have been selected and trained by Edgenuity to specialize in online instruction. Students and parents will communicate consistently with the online instructor who will promptly review assignments and provide meaningful feedback.

Hickman County will strive to support all students enrolled in the virtual learning program while on their pathway of online learning. While parents and students may complete their required coursework offsite at their home, a tutoring lab will be made available to students twice per week. A certified teacher of the Hickman County School System will be available for support during tutoring lab hours. This support is in addition to the access students and parents will have to their Edgenuity online instructor. The school coordinator will also be available during regular business hours to support families of students enrolled in the virtual learning program.

The Transportation Department would like to declare the following items surplus;

School Buses

Bus 02 VIN 1HVBGAAN11A916602	Age of Service
Bus 07 VIN 1HVBGAAN24A961732	Age of Service
Bus 11 VIN 1HVBGAAN31A916603	Age of Service
Bus 24 VIN 1HVBGAAN51A916604	Age of Service
Bus 62 VIN 4DRBGAAN12A947884	Age of Service
Bus 63 VIN 4DRBGAAN32A947885	Age of Service

White Fleet

1998 Ford Ranger 1FTYR10X0WUB23584	Bad suspension	22 yrs
2001 Dodge Caravan #71B4GP44391B199428	No A/C	19 yrs

Miscellaneous brake drums and obsolete parts

Hickman County Board of Education

	Descriptor Term: Family Life Education	Descriptor Code: 4.2013	Issued Date: 02/03/20
		Rescinds: 4.2013	Issued: 12/04/17

1 Boards of education in counties in which the pregnancy rates exceed 19.5 pregnancies per 1,000
2 females ages fifteen (15) through seventeen (17) shall devise, adopt and implement a program of
3 family life education according to the guidelines established by the State Board of Education.¹

4 The Board shall annually evaluate the program and shall conduct public hearings and parental
5 conferences at least once (1) each September as part of the evaluation.

6 A parent who chooses not to have a student participate in the family life education program shall
7 submit such request in writing to the director of schools. A student who is excused from family life
8 instruction shall be assigned alternative activities and shall not be penalized academically.

9 Prior to implementing the family life education curriculum, the Board shall conduct at least one (1)
10 public hearing at which the plan will be explained and parents and community members shall be given
11 the opportunity to express their opinions.

12 The goals of instruction for the family life education program shall be to:²

- 13 1. Provide accurate information about human reproduction, including conception, birth, and
14 prenatal care, with specific emphasis on the family unit and the responsibilities and
15 consequences relating to sexual activity;
- 16 2. Adapt this information to the age and grade level of students;
- 17 3. Promote, encourage and increase communication between parents and students;
- 18 4. Increase decision-making skills;
- 19 5. Offer information that will help students act responsibly; and
- 20 6. Enhance and develop the student's self-esteem.

21 Within these goals and at appropriate age and grade levels, the information presented will include:

- 22 1. Anatomy, physiology, and psychology of adolescence and sexual growth;
- 23 2. Marriage and responsibilities of family life;
- 24 3. Responsibilities of parents and child care;
- 25 4. Legal aspects of sexual conduct;
- 26 5. Self-respect, self-control, and individual differences among people;
- 27 6. Community resources; and
- 28 7. Pregnancy and childbirth.

- 1 Instruction on the detection, intervention, prevention, and treatment of: (A) Child sexual abuse,
- 2 including such abuse that may occur in the home, in accordance with the declarations and requirements
- 3 of §§ 37-1-601(a) and 37-1-603(b)(3); and (B) Human trafficking in which the victim is a child.
- 4 Instruction on family life education shall emphasize that abstinence from sexual relations is the only
- 5 method of protection that is 100% effective.

- 6 Personnel involved in instruction regarding human sexuality will conduct such instruction with
- 7 maturity and discretion. Personnel providing family life instruction shall receive in-service training
- 8 prior to presenting such instruction.

Legal References

1. TCA 49-6-1302
2. TCA 49-6-1301

Hickman County Board of Education

Descriptor Term: Risk Management and Threat Assessment Team	Descriptor Code: 3.204	Issued Date: 12/02/19
	Rescinds: 3.204	Issued: 12/04/17

1 It shall be the responsibility of the director of schools to develop an appropriate safety program for the
2 school system. The Board shall provide sufficient staff and budget for its implementation.

3 The Board shall designate a professional staff person who shall be responsible for the promotion and
4 development of a prevention and safety education program for students and personnel employed by the
5 school system. This person shall be given authority and title commensurate with the task and shall
6 answer directly to the director of schools. The general areas of responsibilities include, *but are not*
7 *limited to*, in-service training, development of accident prevention procedures, accident record keeping
8 and facility inspection.

9 General¹

New

10 A threat assessment team shall be created within the school district to develop intervention-based
11 approaches to prevent violence, manage reports of potential threats, and create a system that fosters a
12 safe, supportive, and effective school environment. The Director of Schools shall appoint the members
13 of the threat assessment team.

14 The Director of Schools shall develop administrative procedures regarding the training and operations
15 of the team to comply with state law and State Board of Education rules and regulations.

16 TEAM MEETINGS

17 All threat assessment team meetings shall be closed to the public.²

18 RECORDKEEPING³

19 The team shall document all behaviors and incidents deemed to pose a risk to school safety or that
20 resulted in intervention and shall provide the information to the Director of Schools.

21 A report of the activities of the threat assessment team will be compiled and shared with the Board
22 before each regular meeting.

23 Documents produced or obtained regarding these assessment activities will not be open for public
24 inspection.

Legal References

1. TCA 49-6-2701 et seq.
2. TCA 49-6-2701(f)
3. TCA 49-6-2702(g); TCA 49-6-2702

Cross References

School District Records 1.407
Safety 3.201
Security 3.205
Student Records 6.600

Insurance Management 3.600
Workers' Compensation 3.602

Hickman County Board of Education

Monitoring: Review: Annually, in November	Descriptor Term: Field Trips / Excursions / Competitions	Descriptor Code: 4.302	Issued Date: 01/08/18
		Rescinds: 4.302	Issued: 09/09/02

- 1 The Board encourages field trips when the experiences are an integral part of the school curriculum
 2 and contribute to the Board's desired educational goals.
- 3 The following guidelines shall be followed in planning and conducting field trips and excursions:
- 4 1. Any teacher desiring to take a group of students on an educational field trip must obtain
 5 advance approval of the principal and the director of schools;
 - 6 2. The trip must have a definite purpose and reflect careful planning. Students should be
 7 prepared by general class discussion and/or research;
 - 8 3. If bus transportation is required, the principal or his/her designee shall make the necessary
 9 arrangements. A fee will be charged to the school for mileage when school system buses
 10 are used;
 - 11 4. Signed parental permission forms must be obtained for every student making an off-campus
 12 trip beyond the immediate vicinity of the school. The principal shall ensure that these
 13 forms are kept on file for the remainder of the school year. The form for parental
 14 permission must include: purpose, date, time of departure and return, travel plans,
 15 destination, number of chaperones, personal expense involved, rules of conduct and
 16 penalties for violation, and other facts necessary for parents to be fully informed. This
 17 information is to be completed by the school before the form is signed by the parent;
 18
 - 19 5. No day field trip shall extend beyond twelve (12) hours.
 - 20 6. Overnight educational trips and chaperones must be approved by the principal and the
 21 director of schools in advance. These groups must be accompanied by at least one regular
 22 staff member and others from the school who are appropriate for adequate supervision and
 23 shall be responsible for student conduct while away. There must be at least one female and
 24 one male chaperone if the trip is for a mixed group;
 25
 - 26 7. Students shall not be penalized for participating in approved school-sponsored trips and
 27 activities. Teachers shall permit students to make up class assignments missed because of a
 28 trip or activity;
 - 29 8. All accidents that occur on a school-sponsored trip must be reported by the teacher to the
 30 principal immediately upon returning to school. Serious accidents involving personal
 31 injury must be reported immediately to the principal and/or director of schools. An

1 emergency shall be dealt with promptly by the teacher or other members of the school staff
2 by taking appropriate action, including sending the student to the hospital or summoning
3 medical aid or ambulance. In cases where it is necessary to send the student to the hospital,
4 reasonable effort must be made to notify the parents.

- 5 9. Any school-sponsored trip which is out-of-state and/or overnight must have prior approval
6 by the Board.
7

8 **INDEPENDENTLY PLANNED TRIPS**

replace current
wording with this

9 Trips privately planned by school district employees, acting outside the scope of their
10 employment, are not authorized by the school district.

11 These trips are not approved by the Board and are not considered a part of the curriculum. Total
12 responsibility for privately planned trips rests with the chaperone(s) as well as with the
13 parent(s)/guardian(s) of the students participating in the trip. The following restrictions shall
14 apply:

- 15 1. Board funds or resources shall not be used;
- 16
- 17 2. School district materials shall not be used;
- 18
- 19 3. The Board shall not assume any liability;
- 20
- 21 4. Employees are not authorized to act on behalf of the school district;
- 22
- 23 5. Recruitment efforts made by an employee shall not occur during the instructional school
24 day; and
- 25
- 26 6. Absences caused by participation in privately planned trips shall be considered
27 unexcused.
- 28
- 29

Cross References

Special Use of School Vehicles 3.402
Extracurricular Activities 4.300
Attendance 6.200
Advertising and Distribution of Materials in the Schools
1.806

Hickman County Board of Education

Monitoring: Review: Annually, in November	Descriptor Term: Graduation Activities	Descriptor Code: 4.606	Issued Date: 04/02/18
		Rescinds: 4.606	Issued: 02/05/18

1 Students who have met all graduation requirements on the day of graduation and students who are
2 within two (2) or fewer credits of meeting all requirements¹ and can complete the requirements during
3 the summer may participate in graduation activities. If extenuating circumstances exist at any school,
4 the matter shall be presented to the Board prior to graduation activities.

5 Students are expected to participate in all graduation activities, and graduation apparel shall be
6 determined by the administration of each school and shall be the personal expense of each student.
7 Any fees required for graduation ceremonies shall be waived for students who are eligible to receive
8 free or reduced price lunches, and in such cases, the school shall assume responsibility for payment of
9 fees.²

10 Graduation ceremonies shall be physically accessible to all students, their parents and/or guardians,
11 and other interested citizens.³

12 Students who do not wish to participate in graduation activities shall notify the school principal in
13 writing at least five (5) days prior to the day of graduation. Non-participating students shall receive
14 their diplomas or certificates from the principal's office within one (1) week of the day of graduation.

15 *replace with this*
16 Graduation activities organized by district employees shall not be religious in nature.⁴ The content of
17 any students' speeches shall not reflect the endorsement, sponsorship, position, or expression of the
school, employees, or Board.

18 The director of schools shall develop procedures to ensure that students are recognized at graduation
19 ceremonies for the following achievements:⁵

- 20 • Honors;
- 21 • State Honors;
- 22 • State Distinction;
- 23 • District Distinction;
- 24 • Tri-Star Scholar;
- 25 • Students receiving a TN Seal of Biliteracy;
- 26 • Students voluntarily completing at least ten (10) hours of community service each semester the
27 student is in attendance at a public high school;
- 28 • Students receiving a gold or platinum medal on National Career Readiness Certificate; and
- 29 • Students graduating with a district-developed work ethic distinction.

Legal References

1. TCA 49-6-405
2. TCA 49-2-114
3. 28 CFR § 36.201
4. *Lee v. Weisman*, 505 U.S. 577(1992), 112 S. Ct. 2649, 120 L. Ed. 2d 467 (1992)
5. TRR/MS 0520-01-03-.06(1)(b); State Board of Education Policy 2.103; Public Acts of 2017, Chapter No. 207

Cross References

Section 504 & ADA Grievance Procedures 1.802
Student Fees and Fines 6.709

Hickman County Board of Education

Monitoring: Review: Annually, in November	Descriptor Term: Use of Multimedia	Descriptor Code: 4.408	Issued Date: 02/05/18
		Rescinds: 4.408	Issued: 07/07/14

- 1 All multimedia used in the classroom must either be provided by the school or have the prior approval
- 2 of the principal.

- 3 Movies, songs or other multimedia may be rented or purchased for use in the classroom for education
- 4 purposes only. No movie, song or other multimedia will be used in the classroom for entertainment
- 5 purposes.

Cross References

Use of Copyrighted Materials 4.404

Hickman County Board of Education

Monitoring: Review: Annually, in November	Descriptor Term: Community Instructional Resources	Descriptor Code: 4.500	Issued Date: 02/05/18
		Rescinds: 4.500	Issued: 08/02/99

1 **COMMUNITY RESOURCE GUIDES**

2 An inventory of community resource people, agencies and establishments which have potential to
3 enhance teaching and learning shall be conducted for each school and kept current to assist in
4 instructional planning.

5 **USE OF COMMUNITY RESOURCE PERSONS**

6 The Board recognizes the value of community resource persons in the educational program and
7 authorizes the use of such persons with approval of the principal.

Hickman County Board of Education

Monitoring: Review: Annually, in November	Descriptor Term: School Volunteers	Descriptor Code: 4.501	Issued Date: 02/05/18
		Rescinds: 4.501	Issued: 07/07/14

- 1 The Board endorses a volunteer program in the schools¹ and authorizes principals to develop a
- 2 volunteer program for each school.

- 3 All volunteers must be approved by the principal and shall serve under the supervision and direction of
- 4 the professional personnel of the school to which they are assigned. Volunteers shall assist professional
- 5 personnel in the performance of their teaching and administrative responsibilities. They may not teach
- 6 but may reinforce skills taught by the professional staff.

- 7 The principal shall identify appropriate tasks for volunteers and shall be responsible for planning and
- 8 conducting orientation programs and regular in-service training sessions.

- 9 Volunteers shall serve without compensation.²

- 10 The principal shall ensure that appropriate recognition of volunteer services is made annually.

- 11 The director of schools shall develop procedures to require appropriate background checks for
- 12 volunteers who may work closely with students without much or any supervision of district employees.

Legal References

1. TCA 49-6-7001
2. TCA 29-20-310 (e)

Cross References

Visitors to the School 1.501

Hickman County Board of Education			
Monitoring: Review: Annually, in June	Descriptor Term: Parental and Family Involvement	Descriptor Code: 4.502	Issued Date: 02/05/18
		Rescinds: 4.502	Issued: 03/06/17

1 **GENERAL EXPECTATIONS FOR PARENTAL INVOLVEMENT**

2 The board is committed to increasing and ensuring the involvement of parents and other family members in the
3 education of students.

4 The board shall implement the following as required by federal or state laws or regulations:¹

- 5 • The school district shall annually work with parents in evaluating and potentially revising the provisions
6 of this policy in improving the quality of schools. Such an evaluation shall strive to identify any barriers
7 to greater participation by parents (with particular attention to parents who are economically
8 disadvantaged, are disabled, have limited English proficiency, have limited literacy, or are of any racial
9 or ethnic minority background).
- 10 • The school district shall provide the coordination, technical assistance, and other necessary support to
11 assist individual schools with planning and implementing parental involvement activities.
- 12 • The school district shall involve parents with the development of required educational or improvement
13 plans.
- 14 • The school district shall coordinate and integrate parental involvement strategies with those associated
15 with other federal or state programs.
- 16 • The school district shall put into operation activities and procedures for the involvement of parents in all
17 of its schools.² Those programs, activities and procedures will be planned and operated with meaningful
18 consultation with parents.
- 19 • The school district shall ensure that activities and strategies are implemented to support this policy and
20 included in the district plan.
- 21 • The district improvement plan shall include strategies for parental participation in the district's schools
22 which are designed to improve parent and teacher cooperation in such areas as homework, attendance,
23 discipline and higher education opportunities for students.
- 24 • The district plan shall include procedures to enable parents to learn about the course of study of their
25 children and have access to all learning materials.
- 26 • The district plan shall identify opportunities for parents to participate in and support classroom
27 instruction in the school. Such opportunities include, but are not limited to, organizing fundraising
28 activities, volunteering as a field trip chaperone, assisting in the library, computer lab, or on the
29 playground, offering after-school clubs, and recycling clothes.
- 30 • If the school district's plan is not satisfactory to parents, the school district shall submit parental
31 comments regarding the plan to the State Department of Education as required.

- 1 • The school district shall ensure Title I schools are in compliance with the *Every Student Succeeds Act*.
2 The director shall develop and implement any procedures necessary to accomplish the goals of this policy.

3 **SCHOOL LEVEL POLICY**

4 Each school shall submit to the director and board, for review and comment, its Title I school parent
5 involvement policy, which must meet state and federal requirements, including a school-parent compact. This
6 school level policy shall be developed jointly with and distributed to parents of participating students. A copy of
7 these documents shall be retained in the district office and made available on the school's (if applicable) and
8 school system's website.

9 **SUPPORT FOR PROGRAM**

10 If the Title I allocation is \$500,000 or more to the school system, then not less than one per cent (1%) nor more
11 than five percent (5%) of that allocation shall be reserved for the purpose of promoting parent involvement.
12 Parents of students participating in the Title I programs shall be consulted on the use of these funds.

13 **FAMILY-SCHOOL PARTNERSHIPS¹**

14 Families and community members should be engaged in the education of students based on the following
15 standards:

- 16 • Families are welcomed into the school community;
- 17 • Families and school staff should engage in regular and meaningful communication about student
18 learning;
- 19 • Families and school staff work together to support student learning and development;
- 20 • Families are informed and encouraged to be advocates for students;
- 21 • Families are full partners in the decisions that affect children and families; and
- 22 • Community, civic, and business resources are made available to strengthen school programs, family
23 practices, and student learning.
24

Legal References

1. Every Student Succeeds Act, Pub.L. 114-95, Dec. 10, 2015, 129 Stat. 1802; TCA 49-6-7001; State Board of Education, Tennessee Parent/Family Involvement Policy 4.207; TCA 49-2-305
2. TCA 49-6-7001

Hickman County Board of Education

Monitoring: Review: Annually, in November	Descriptor Term: <h2 style="margin: 0;">Grading System</h2>	Descriptor Code: 4.600	Issued Date: 03/05/18
		Rescinds: 4.600	Issued: 08/07/17

1 The director of schools shall develop an administrative procedure to establish a system of grading and
 2 assessment for evaluating and recording student progress and to measure student performance in
 3 conjunction with Board-adopted content standards for grades K-8.¹ The grading/assessment system
 4 shall follow all applicable statutes and rules and regulations of the State Board of Education.² The
 5 grading/assessment system shall be uniform district-wide at comparable grade levels except that the
 6 director of schools shall have the authority to establish and operate ungraded and/or unstructured
 7 classes in grades K-3.³

8 The director of schools shall submit a copy of the grading, reporting and assessment systems to the
 9 Board before the system is implemented.⁴ These guidelines shall be communicated annually to students
 10 and parents/guardians.¹

11 **GUIDELINES**

12 Subject-area grades shall be expressed by the letters “A”, “B”, “C”, “D”, and “F”, or with their
 13 corresponding numerical values.

14	A	93 - 100
15	B	85 - 92
16	C	75 - 84
17	D	70 - 74
18	F	0 - 69 ¹

19 The following high school courses will have weighted grades:

- | | |
|--|--|
| 20 Honors English (Grades 9-12)
21 Honors Biology I
22 Honors Physical Science
23 Honors Chemistry
24 Honors Physics
25 Anatomy | Trigonometry
Honors Algebra II
Honors Geometry
Dual Enrollment College Courses
Honors American History
Honors Algebra I |
|--|--|

1 Conduct grades are based on behavior and shall not be deducted from scholastic grades.

2 Attendance records **will not** be the sole criterion in determining the awarding of grades or the passing
3 of a course or promotion or retention.⁴

4 Plus and minus evaluations are not to be added to letter grades. Grades are not to be changed once
5 recorded on a report card. If an erroneous grade has been recorded, correction must be made on a new
6 card.

7 Grades given at the end of each nine (9) weeks period for elementary, intermediate, middle school, and
8 high school will be determined from daily work, homework, written assignments and tests. The
9 teacher will weigh the value of grades given for various assignments and tests within the applicable
10 period in computing the grade. This procedure will enable the teacher to allow for individual student
11 differences in the grading process. Any assignments and tests required of a student must be considered
12 in the computation of his grade.

13 At the middle school level and at the high school level, grades will be determined by an average of
14 grades for each of the two 9-week periods. The grades given at the end of each nine (9) weeks period
15 shall be the grade earned by the student, as computed by the teacher, and shall not be subject to
16 manipulation, regardless of the passing or failing nature of the grade provided that said teacher has
17 documented verification on file that he/she has reasonably attempted to contact the student's parent(s)
18 or guardian(s) making them aware of the student's failing grade or grades. The final grade of the year
19 will be determined by averaging the two (2) semester grades.

20 The work of a student whose grades are satisfactory but are withheld because of failure to complete the
21 required work shall be reported as incomplete (I). If the incomplete is not removed in the time
22 designated by the teacher, it will then become an "F".

23 **GRADES NINE - TWELVE GRADING SCALE AND LOTTERY SCHOLARSHIPS** ⁶

24 Schools teaching grades nine through twelve shall use the uniform grading system established by the
25 State Board of Education. Using the uniform grading system, students' grades shall be reported for the
26 purposes of application for post secondary financial assistance administered by the Tennessee Student
27 Assistance Corporation.¹

1 Each school counselor shall provide incoming freshman with information on college core courses
2 required for lottery scholarships as well as necessary criteria (grade point average, ACT, and SAT
3 score, etc.) that must be met in order to receive a scholarship.

4 Seniors may apply for the Tennessee HOPE Scholarship by completing the Free Application for
5 Federal Student Aid (FAFSA). The FAFSA is available at the guidance office or on-line at
6 www.fafsa.ed.gov. Students shall be made aware of all applicable FAFSA deadlines and encouraged to
7 submit applications in a timely manner.

8 Elementary school counselors should explain the HOPE Scholarship and its requirements to their
9 students and impress upon them the benefits of making good grades.

10 **LOTTERY SCHOLARSHIP DAY**

11 Each school year, prior to scheduling courses for the following school year, schools teaching students
12 in grades 8-11 shall conduct a lottery scholarship day for students and their parents.⁷

Legal References

1. TRR/MS 0520-1-3-.05(3)
2. TCA 49-1-3-06
3. TCA 49-1-302
4. TCA 49-2-203(b)(7)
5. TCA 49-1-617
6. TCA 49-4-904-907; SBOE Policy 3.301
7. Public Acts 2006, Chapter 909

Hickman County Board of Education

Monitoring: Review: Annually, in November	Descriptor Term: Reporting Student Progress	Descriptor Code: 4.601	Issued Date: 02/05/18
		Rescinds: 4.601	Issued: 08/27/12

1 Student report cards shall be provided once every nine (9) weeks during the school year. The reporting
 2 procedure shall be in writing and shall be uniform for all reporting periods during each school year.¹
 3 Each report shall be signed by the parents and returned promptly to the school.

4 Student progress reports shall indicate the students' conduct, attendance and academic progress and other
 5 information necessary to communicate effectively with the parents.

6 In addition to the regular progress reports, principals and teachers are encouraged to confer with parents
 7 on the educational progress of their children. Teachers shall consult with parents of students who are
 8 working at an unsatisfactory level or whose performance shows a marked or sudden deterioration.
 9 Parents shall be notified by the teacher as early in the school year as possible if the retention of a student
 10 is being considered.

11 **DRIVER'S LICENSE REVOCATION**

12 Any student fifteen (15) years of age or older who becomes academically deficient shall be reported to
 13 the Department of Safety for driver's license revocation.

14 A student shall be deemed academically deficient if he/she has not received passing grades in at least
 15 three (3) full unit subjects or their equivalency at the end of semester grading.

16 A copy of the notice sent to the Department of Safety by the attendance teacher or the director of schools
 17 or his/her designee shall also be mailed to the student's parent or guardian.²

18 **PARENT CONFERENCES**

19 At least two (2) times during the school year, conferences shall be scheduled in which parents and
 20 teachers may discuss any pertinent problems or other matters of concern regarding the development and
 21 education of each student. These scheduled conferences shall not use any portion of the 180 days of
 22 classroom instruction.³ The director of schools shall be responsible for scheduling and coordinating
 23 systemwide conferences.

24 Conferences shall be physically accessible to all students, parents and/or guardians.⁴

Legal References

1. TRR/MS 0520-01-03-.05(3)(a); TCA 49-6-901
2. TCA 49-6-3017
3. TCA 49-6-7002
4. 28 CFR § 36.201

Cross References

School Calendar 1.800
Section 504 & ADA Grievance Procedures 1.802
Grading System 4.600
Promotion and Retention 4.603
Staff Time Schedules 5.602
Attendance 6.200

Hickman County Board of Education

Monitoring: Review: Annually, in November	Descriptor Term: <h2 style="margin: 0;">Homework</h2>	Descriptor Code: 4.6011	Issued Date: 02/05/18
		Rescinds: 4.6011	Issued: 08/02/09

- 1 The Board recognizes that some homework by students is desirable and necessary. To be effective,
- 2 homework shall be carefully planned, judiciously assigned and systematically evaluated.

- 3 Homework is to be assigned to reinforce and strengthen specific areas of interest and opportunities. It
- 4 must never be given for punishment.

- 5 Homework assignments should be made by the teacher in cooperation with the students and other
- 6 teachers, under the overall supervision of the principal. All homework shall be received by the teacher
- 7 making the assignment and credit given for the student's efforts.

- 8 Homework assignments shall take into consideration individual differences of students such as health,
- 9 ability, conditions of home, and educational resources at home. Homework shall not require the use of
- 10 reference materials not readily available in most homes, school libraries or the public library.

- 11 Homework shall not be in continuing conflict for time with the home and other community agencies
- 12 having primary responsibility for certain aspects of the student's development.

HOMEWORK GUIDELINES

- 14 Grades 1 and 2 - If necessary, homework should not exceed fifteen (15) minutes per day.

- 15 Grades 3 and 4 - If necessary, homework should not exceed thirty (30) minutes per day.

- 16 Grades 5 and 6 - If necessary, homework should not exceed ten (10) minutes per subject or
- 17 forty-five (45) minutes per day

- 18 Grades 7 and 8 - If necessary, homework should not exceed fifteen (15) minutes per subject
- 19 or sixty (60) minutes per day.

- 20 Grades 9 to 12 - If necessary, homework should not exceed thirty (30) minutes per subject
- 21 per day.

Hickman County Board of Education

Monitoring: Review: Annually, in November	Descriptor Term: <h2 style="text-align: center;">Class Ranking</h2>	Descriptor Code: <h3 style="text-align: center;">4.602</h3>	Issued Date: <h3 style="text-align: center;">02/05/18</h3>
		Rescinds: <h3 style="text-align: center;">4.602</h3>	Issued: <h3 style="text-align: center;">07/07/14</h3>

- 1 Students must be enrolled full time at the home base school to be eligible for ranking among the top high school
- 2 seniors.

- 3 All grades (excluding those gained after the initial athletic participation grade) earned in grades 9,10,11 and the
- 4 first semester of grade 12 will be counted toward the grade point average and the rank in class.

- 5 Honor roll students will be determined by standards approved by the principal and faculty of each school.
- 6 Students who meet these standards, and who do not request otherwise, will have their names submitted to the
- 7 principal each nine (9) weeks for release to the local newspaper.

- 8 Each school department or club which presents honors or awards or conducts contests will file with the principal
- 9 the name of the honor, award or contest; the basis for selection of the award and honor; the method of
- 10 participation; and the reason for the contest.

- 11 The giving of any prize or medal or the making of any award by persons or agencies outside the schools must
- 12 have the approval of the Board.

- 13 To become valedictorian or salutatorian, or ranked in the top ten, a student must be enrolled in the high school at
- 14 least four (4) of the seven (7) semesters preceding the final semester. The final semester will not be used in
- 15 determining class standing.

- 16 ***Exception***

- 17 When a new high school is opened in the school system, for the first year, a senior student must be enrolled at
- 18 the new high school for a majority of the first semester and have been enrolled in one of the school system's
- 19 other high school(s) for at least three (3) of the seven (7) semesters preceding the final semester; for the second
- 20 year, a senior student must have been enrolled at the new high school for three (3) semesters and have been
- 21 enrolled at one of the school system's other high school(s) at least one (1) semester of the seven (7) semesters
- 22 preceding the final semester; for the third year, a senior student must have been enrolled at the new high school
- 23 for four of the five semesters preceding the final semester; for the fourth year and beyond, the provisions of the
- 24 preceding paragraph apply. For those students who do not meet the exception criteria, their high school grades
- 25 (i.e., Hickman County and other school systems) will be compiled for a grade ranking of the class.

Cross References

Grading System 4.600
 Graduation Requirements 4.605

Hickman County Board of Education

	Descriptor Term: Promotion and Retention	Descriptor Code: 4.603	Issued Date: 04/01/19
		Rescinds: 4.603	Issued: 04/02/18

1 **PROMOTION**¹

2 The director of schools/designee shall promote students to the next grade level based on the successful
3 completion of required academic work and on the satisfactory progress in each of the relevant
4 academic areas. However, no student enrolled in the third grade shall be promoted unless the student
5 has shown a basic understanding of curriculum and the ability to perform the skills required in the
6 subject of reading as demonstrated by the student's grades or standardized test results. This
7 requirement shall not apply to students who are participating in a board-approved, research-based
8 intervention prior to the beginning of the next school year or to students who have an individualized
9 education program (IEP).²

10 Students who have difficulty in achieving the requirements for promotion may be considered for
11 retention. Factors used to identify students for retention shall include:²

- 12 1. The student's ability to perform at the current grade level;
- 13
- 14 2. The results of local assessments, if applicable;
- 15
- 16 3. State assessments, as applicable;
- 17
- 18 4. The overall academic achievement of the student;
- 19
- 20 5. The student's chance for success with more difficult material if promoted to the next grade;
- 21
- 22 6. Attendance; and
- 23
- 24 7. Social and emotional maturity.
- 25

26 Students may be identified for retention after the February 1st deadline if the delay in identifying a
27 student is due to:

- 28 1. Date of enrollment;
- 29
- 30 2. Additional information acquired after results of local assessment, screening, or monitoring are
31 released; or
- 32

1 3. Decisions made by a student's IEP team or extenuating medical or psychological information
2 on a case by case basis.

3 When a student is considered for retention, the student's parent/guardian shall be notified within
4 fifteen (15) days, and an individualized promotion plan shall be developed to help the student avoid
5 retention. This plan will be provided to the student's parent/guardian.

6 The director shall develop procedures governing how decisions on retention will be made after the
7 student begins work on his/her individualized promotion plan.

8 *K – 3 Reading Notification*

9 If it is determined through a student's overall performance or a state or local assessment that a student
10 in grades kindergarten through three (K-3) is not meeting grade-level standards in reading, the
11 student's parent(s)/guardian(s) shall be notified within fifteen (15) calendar days of such
12 determination.

13 **RETENTION¹**

14 A student may be retained when, in the judgment of the student's teacher and/or the student's IEP
15 team, such retention is in the best interest of the student. However, a student shall not be retained more
16 than once in any grade.

17 If a student is retained, the director of schools/designee shall develop an individualized academic
18 remediation plan prior to the start of the next school year. A copy of the plan shall be provided to the
19 student's parent/guardian within ten (10) days of its development. This plan shall include at least one
20 of the following strategies:

- 21 1. Adjustment to the current instructional strategies or materials;
- 22
- 23 2. Additional instructional time;
- 24
- 25 3. Individual tutoring outside of school hours;
- 26
- 27 4. Modification to the student's classroom assignment to ensure the student receives
28 instruction from a highly effective teacher; or
- 29
- 30 5. Attendance or truancy interventions.

31 The director of schools shall develop procedures to ensure proper monitoring of students who are
32 retained and appropriate recordkeeping.

33 For the purpose of determining the effectiveness of retention toward improving student achievement,
34 the progress of retained students shall be closely monitored and reported to parent(s)/guardian(s) at
35 least three (3) times during the school year in which the student is retained.

Legal References

1. State Board of Education Policy 3.300; TRR/MS 0520-01-03-.05(3)(b)
2. TCA 49-6-3115; 20 USCA § 1400 et seq.

Cross References

Credit Recovery 4.210
Grading System 4.600
Reporting Student Progress 4.601
Attendance 6.200
Student Assignments 6.205

Hickman County Board of Education			
	Descriptor Term: Graduation Requirements	Descriptor Code: 4.605	Issued Date: 12/02/19
		Rescinds: 4.605	Issued: 10/07/19

1 *General*

2 The program of studies shall include areas required by the State Board of Education.

3 Before high school graduation, every student shall:¹

- 4 1. Achieve the specified twenty-eight (28) units of credit;
- 5 2. Have satisfactory records of attendance and conduct;
- 6 3. Take the ACT or SAT prior to graduation;² and
- 7 4. Pass a United States civics test.³

8 Students achieving the minimum twenty-two credits will be awarded a state diploma. In order to receive
9 a Hickman County diploma, students shall obtain twenty-eight credits.

10 **SPECIAL EDUCATION STUDENTS⁴**

11 Special education students who earn the prescribed twenty-eight (28) credit minimum shall be awarded
12 a regular high school diploma.

13 *Special Education Diploma*

14 A special education diploma shall be awarded to students who have not met the requirements for a regular
15 high school diploma,⁵ but have:

- 16 1. Completed four (4) years of high school;
- 17 2. Made satisfactory progress on their IEP; and
- 18 3. Maintained satisfactory records of attendance and conduct.

19 *Occupational Diploma*

20 Special education students who do not meet the requirements for a regular high school diploma may be
21 awarded an occupational diploma if the student has:^{1,4}

- 22 1. Completed at least four (4) years of high school;
- 23 2. Made satisfactory progress on their IEP;
- 24 3. Maintained satisfactory records of attendance and conduct;
- 25 4. Completed the occupational diploma Skills, Knowledge, and Experience Mastery Assessment
26 (SKEMA); and
- 27 5. Has two (2) years of paid or non-paid work experience.

1 The decision to attain an occupational diploma shall be made at the conclusion of the student's 10th grade
2 year or two (2) academic years prior to the expected graduation date.

3 Students who have received a special education diploma or an occupational diploma shall continue to
4 make progress towards a regular high school diploma until the end of the school year in which they turn
5 twenty-two (22) years old.

6 *Alternate Academic Diploma*

7 Special education students who do not meet the requirements for a regular high school diploma may be
8 awarded an alternate academic diploma if the student has:⁴

- 9 1. Completed at least four (4) years of high school;
- 10 2. Participated in the high school alternate assessments;
- 11 3. Earned the prescribed twenty-two (22) credit minimum;
- 12 4. Made satisfactory progress on their IEP;
- 13 5. Maintained satisfactory records of attendance and conduct; and
- 14 6. Completed a transition assessment that measures postsecondary education and training,
15 employment, independent living, and community involvement.

16 **STUDENT LOAD**

17 All full time students in grades 9-12 shall be enrolled each semester in subjects that produce a minimum
18 of five (5) units of credit for graduation per year. Students with hardships and gifted students may appeal
19 this requirement to the director of schools and then to the board.⁶

20 **EARLY GRADUATION⁷**

21 High school students shall be permitted to complete an early graduation program. Students intending to
22 graduate early shall inform the school principal of this intent prior to the beginning of 9th grade or as
23 soon thereafter as the intent is known.

24 In order to graduate early, students must meet the following requirements:

- 25 1. Earn the required eighteen (18) credits;
- 26 2. Achieve a benchmark score for each required end-of-course exam;
- 27 3. Attain a cumulative GPA of at least 3.2 on a 4.0 scale;
- 28 4. Meet the minimum ACT or SAT benchmark score;
- 29 5. Obtain a qualifying benchmark score on a world language proficiency assessment; and
- 30 6. Complete at least two (2) types of the following courses:
 - 31 a. AP;
 - 32 b. IB;
 - 33 c. Dual enrollment; or
 - 34 d. Dual credit.

35 The director of schools shall develop administrative procedures to ensure that the early graduation
36 program is conducted in accordance with state law.

Legal References

1. TCA 49-6-6001; State Board of Education Policy 2.103
2. TCA 49-6-6001(b); State Board of Education Policy 2.103
3. TCA 49-6-408; Public Acts of 2019, Chapter No. 442; State Board of Education Policy 2.103
4. TRR/MS 0520-01-03-.06(1)(a); State Board of Education Policy 2.103
5. TCA 49-6-6005; State Board of Education Policy 2.103
6. TRR/MS 0520-01-03-.06(1)(a)(7)
7. TCA 49-6-8303; State Board of Education Policy 2.103

Cross References

Basic Curriculum Program 4.201
Alternative Credit Options 4.209
Honor Roll, Awards, & Class Ranking 4.602

Hickman County Board of Education

Monitoring: Review: Annually, in April	Descriptor Term: Waivers of Statute, Rules and Regulations	Descriptor Code: 4.607	Issued Date: 02/05/18
		Rescinds: 4.607	Issued: 10/02/06

- 1 If the Board determines that it is in the best interest of the school district, application may be made to ,
- 2 the commissioner of education for a waiver of any state board rule or regulation that inhibits or hinders
- 3 the Board's ability to implement programs designed to improve student achievement.¹ However, the
- 4 Board will not seek a waiver from those rules and regulations that are specifically excluded by state law.

- 5 Further, the Board may request from the Commissioner of Education a waiver of state law, rule or
- 6 regulation from maximum class sizes in the event a natural disaster has caused displaced students to
- 7 become enrolled in the school district.²

Legal References

1. TCA 49-1-201(d)(1)
2. TCA 49-1-104(f)

Tennessee Internal School Uniform Accounting Policy Manual
Applicable Laws and Exhibits-Appendix A

Exhibit 1

PROPOSED FUNDRAISING ACTIVITIES

Fund/account name Yearbooks 3053

Proposed fundraising activities: 2019-2020 School
Yearbook Sales

Purposed Uses of funds raised To bid General fund

Expected student involvement (school-wide or specific school organization) _____

Method by which school will receive profit Cash / Check

Requested by Cherille Bonin Date 3.5.2020
Name/Title

Approved by Margaret Tidwell Date 3-5-20
Principal

Approved by Michelle Silver Date 3/6/20
Director of Schools*

* The Director of Schools must approve all fundraising activities that involve the participation of the general student population in the marketing process of the fundraising effort.

Exhibit 1

PROPOSED FUNDRAISING ACTIVITIES

Fund/account name East Hickman Middle School FOOTBALL

Proposed fundraising activities: CHEESECAKE SALE

Purposed Uses of funds raised

PURCHASE FOOTBALL EQUIPMENT / UNIFORMS

Expected student involvement (school-wide or specific school organization)

FOOTBALL PLAYERS

Method by which school will receive profit THE FOOTBALL TEAM WILL

RECEIVE ROUGHLY 40% OF SALES.

Requested by Robert Phillips FOOTBALL COACH Date 3-11-20
Name/Title

Approved by Bryce Ayles Date 3/11/2020
Principal

Approved by Michelle Silver Date 3/13/20
Director of Schools*

* The Director of Schools must approve all fundraising activities that involve the participation of the general student population in the marketing process of the fundraising effort.

PROPOSED FUNDRAISING ACTIVITIES

Fund/account name East Hickman Middle School

Proposed fundraising activities: Yankee Candle

Purposed Uses of funds raised
TO help cover team fees.

Expected student involvement (school-wide or specific school organization) _____
Cheerleaders

Method by which school will receive profit cash

Requested by Cayla Martin/coach Date _____
Name/Title

Approved by [Signature] Date 3/9/2020
Principal

Approved by Michelle Hivert Date 3/9/20
Director of Schools*

* The Director of Schools must approve all fundraising activities that involve the participation of the general student population in the marketing process of the fundraising effort.

Exhibit 1

PROPOSED FUNDRAISING ACTIVITIES

Fund/account name 8th Grade Trip

Proposed fundraising activities: Otis Spunkmeyer
Cookie Dough

Purposed Uses of funds raised Costs of ^{8th Trip} ~~8th~~ Trip

Expected student involvement (school-wide or specific school organization) _____
8th grade Students only

Method by which school will receive profit Direct payment of goods
by purchaser.

Requested by _____ Date _____
Name/Title

Approved by Bryan Argyle Date 3/2/2020
Principal

Approved by Michelle Helvert Date 3/5/2020
Director of Schools*

* The Director of Schools must approve all fundraising activities that involve the participation of the general student population in the marketing process of the fundraising effort.

PROPOSED FUNDRAISING ACTIVITIES



East Hickman High School
7700 Hwy 7, Lyles, TN 37098
Phone 931-670-1366 Fax 931-670-1039

Fund/Account Name Class of 2020

Account Number 702

Proposed fundraising activities: ACT Relief

Purposed Uses of funds raised: graduation / class funds

Expected Student involvement (school-wide or specific school organization): school-wide

Method by which school will receive profit: Cash

Requested by: Sheyl Robinas Name/Title 3-12-20 Date

Approved by: Mark Beer Principal 3-12-20 Date

Approved by: Michelle Levert Director of Schools* 3/13/20 Date

* The Director of Schools must approve all fundraising activities that involve the participation of the general student population in the marketing process of the fundraising effort.

PROPOSED FUNDRAISING ACTIVITIES



East Hickman High School
7700 Hwy 7, Lyles, TN 37098
Phone 931-670-1366 Fax 931-670-1039

Fund/Account Name Girls Track

Account Number 6011

Proposed fundraising activities: Fan Cloth athletic apparel sales

Purposed Uses of funds raised: Will be used to pay conference/meet fees and purchase equipment

Expected Student involvement (school-wide or specific school organization): about 20 track students will be involved

Method by which school will receive profit: Check will be sent from Fan Cloth

Requested by: [Signature] / track coach
Name/Title

3/9/2020
Date

Approved by: [Signature]
Principal

3/11/2020
Date

Approved by: [Signature]
Director of Schools*

3/11/2020
Date

* The Director of Schools must approve all fundraising activities that involve the participation of the general student population in the marketing process of the fundraising effort.

PROPOSED FUNDRAISING ACTIVITIES



East Hickman High School
7700 Hwy 7, Lyles, TN 37098
Phone 931-670-1366 Fax 931-670-1039

Fund/Account Name Class of 2020

Account Number 702

Proposed fundraising activities: Senior shirt sale

Purposed Uses of funds raised: graduation / class funds

Expected Student involvement (school-wide or specific school organization): Senior class

Method by which school will receive profit: CASH or check

Requested by: Sheryl Robinson / Senior class sponsor 3-10-20
Name/Title Date

Approved by: Mindul Beem 3-11-20
Principal Date

Approved by: Michelle Hilvert 3/11/20
Director of Schools* Date

* The Director of Schools must approve all fundraising activities that involve the participation of the general student population in the marketing process of the fundraising effort.

PROPOSED FUNDRAISING ACTIVITIES



East Hickman High School
7700 Hwy 7, Lyles, TN 37098
Phone 931-670-1366 Fax 931-670-1039

Fund/Account Name East Hickman Tennis

Account Number _____

Proposed fundraising activities: fan cloth clothing fundraiser

Purposed Uses of funds raised: Extra funds required for tennis balls, end of year party, etc...

Expected Student involvement (school-wide or specific school organization): Tennis Team

Method by which school will receive profit: _____

Requested by: Lauren Satenisky / Tennis Coach
Name/Title

_____ Date

Approved by: R Mastas
Principal

3-6-2020
Date

Approved by: Michelle Gilbert
Director of Schools*

3/6/20
Date

* The Director of Schools must approve all fundraising activities that involve the participation of the general student population in the marketing process of the fundraising effort.

PROPOSED FUNDRAISING ACTIVITIES

Fund/account name FACS 820

Proposed fundraising activities: DonorsChoose

Purposed Uses of funds raised
Buy books to be used in Culinary
Arts classroom

Expected student involvement (school-wide or specific school organization) None

Method by which school will receive profit School will receive books
delivered by Amazon.

Requested by Charlotte Boehms Date _____
Name/Title

Approved by Mindy Beem Date 2-28-20
Principal

Approved by Nichelle Stewart Date 2/28/20
Director of Schools*

* The Director of Schools must approve all fundraising activities that involve the participation of the general student population in the marketing process of the fundraising effort.

PROPOSED FUNDRAISING ACTIVITIES



East Hickman High School
7700 Hwy 7, Lyles, TN 37098
Phone 931-670-1366 Fax 931-670-1039

Fund/Account Name Cheerleading

Account Number 614

Proposed fundraising activities: Buff City Soap fundraiser

Purposed Uses of funds raised: un:forms, camp clothes & bus expenses

Expected Student involvement (school-wide or specific school organization): cheer squad

Method by which school will receive profit: cash & check

Requested by: Discille Smith, Cheer Coach
Name/Title

2-26-20
Date

Approved by: Mukul Beem
Principal

2-26-20
Date

Approved by: Michelle Albert
Director of Schools*

2/27/20
Date

* The Director of Schools must approve all fundraising activities that involve the participation of the general student population in the marketing process of the fundraising effort.

614

PROPOSED FUNDRAISING ACTIVITIES



East Hickman High School
7700 Hwy 7, Lyles, TN 37098
Phone 931-670-1366 Fax 931-670-1039

Fund/Account Name Cheerleading

Account Number 614

Proposed fundraising activities: Ozark Delight Lollipops

Purposed Uses of funds raised: uniforms, camp clothes, bus expenses

Expected Student involvement (school-wide or specific school organization): Cheer squad

Method by which school will receive profit: cash

Requested by: Discille Smith Cheer Coach 2-26-20
Name/Title Date

Approved by: Michael Beem 2-26-20
Principal Date

Approved by: Michelle Arent 2/27/2020
Director of Schools* Date

* The Director of Schools must approve all fundraising activities that involve the participation of the general student population in the marketing process of the fundraising effort.

PROPOSED FUNDRAISING ACTIVITIES

Fund/account name Cheer / April 9th / TN Ready Pep Rally Event

Proposed fundraising activities: Tik Tok Challenge (\$2 per team member, 3 members max per team) ? Concessions

Purposed Uses of funds raised offset Cheer uniform cost

No charge to attend the event.

Expected student involvement (school-wide or specific school organization) School-wide

Method by which school will receive profit Cash

Requested by Beth Copley, Sponsor Date 3/3/20
Name/Title

Approved by Ima S. Shug Date 3-7-20
Principal

Approved by Michelle Helbert Date 3/10/20
Director of Schools*

* The Director of Schools must approve all fundraising activities that involve the participation of the general student population in the marketing process of the fundraising effort.

PROPOSED FUNDRAISING ACTIVITIES

Fund/account name Student Council

Proposed fundraising activities: Bulldog Ball ~~December~~

Semi-formal event for 6th + 7th gr. / 8th gr. has option for formal wear / HCMS Students only

Purposed Uses of funds raised
help 8th grade with cost of trip

Expected student involvement (school-wide or specific school organization) School wide

Method by which school will receive profit Cash

Requested by Beth Copley, sponsor Date 3/2/20
Name/Title

Approved by [Signature] Date 3-3-20
Principal

Approved by [Signature] Date 3/5/20
Director of Schools*

* The Director of Schools must approve all fundraising activities that involve the participation of the general student population in the marketing process of the fundraising effort.

PROPOSED FUNDRAISING ACTIVITIES

Fund/account name School-wide Fundraiser

Proposed fundraising activities: Selling items (cookies, popcorn, & small household items) out of a pamphlet } Palmetto Fundraising }

Purposed Uses of funds raised Rewards & Instruction

Expected student involvement (school-wide or specific school organization) School-wide (those that wish to participate)

Method by which school will receive profit Currency

Requested by [Signature] Date 3-6-20
Name/Title

Approved by [Signature] Date 3-6-20
Principal

Approved by [Signature] Date 3/6/20
Director of Schools*

* The Director of Schools must approve all fundraising activities that involve the participation of the general student population in the marketing process of the fundraising effort.

PROPOSED FUNDRAISING ACTIVITIES

Fund/account name Beta Club

Proposed fundraising activities: Concession Stands during
Field days (May 5th, 6th, & 7th)

Purposed Uses of funds raised Beta Convention & other School/
Community Activities

Expected student involvement (school-wide or specific school organization) School Wide (HCMS)

Method by which school will receive profit Beta will sell food
& drinks during field day.

Requested by Kassi Holloway Date 03/05/20
Name/Title Beta Sponsor/7th Teacher

Approved by Ima S. Hughes Date 3-6-20
Principal

Approved by Michelle Bivert Date 3/6/20
Director of Schools*

* The Director of Schools must approve all fundraising activities that involve the participation of the general student population in the marketing process of the fundraising effort.

PROPOSED FUNDRAISING ACTIVITIES

Fund/account name Cheer

Proposed fundraising activities: Sell Worlds Finest Chocolate

Purposed Uses of funds raised
to help purchase uniforms

Expected student involvement (school-wide or specific school organization)
School wide

Method by which school will receive profit Cash

Requested by Beth Copley sponsor Date 3/2/20
Name/Title

Approved by Ima S. Lutz Date 3-3-20
Principal

Approved by Michelle Albert Date 3/5/20
Director of Schools*

* The Director of Schools must approve all fundraising activities that involve the participation of the general student population in the marketing process of the fundraising effort.

PROPOSED FUNDRAISING ACTIVITIES

Fund/account name HCM5 Baseball

Proposed fundraising activities: Candles R US

Purposed Uses of funds raised funds to cover baseball
Season

Expected student involvement (school-wide or specific school organization) _____
Baseball players

Method by which school will receive profit check

Requested by Tony Roder Coach Date 2/24/20
Name/Title

Approved by [Signature] Date 2-24-20
Principal

Approved by [Signature] Date 2/26/20
Director of Schools*

* The Director of Schools must approve all fundraising activities that involve the participation of the general student population in the marketing process of the fundraising effort.

PROPOSED FUNDRAISING ACTIVITIES

Fund/account name High School Football

Proposed fundraising activities: Card Sales \$20/card

Purposed Uses of funds raised

Jerseys, Paint, field equipment

Expected student involvement (school-wide or specific school organization)

Cheerleaders, Football, Track

Method by which school will receive profit Donation

Requested by Rodger E. McDonald Date 3-10-20
Name/Title

Approved by Ken D. Esch Date 3/12/2020
Principal

Approved by Michelle Hebert Date 3/13/20
Director of Schools*

* The Director of Schools must approve all fundraising activities that involve the participation of the general student population in the marketing process of the fundraising effort.

PROPOSED FUNDRAISING ACTIVITIES

Fund/account name Football

Proposed fundraising activities: Golf Tournament CMGC

Alumni Fundraiser July 18.

Purposed Uses of funds raised
Jerseys, helmets, shoulder pads

Expected student involvement (school-wide or specific school organization) _____

Football Players, Booster Club

Method by which school will receive profit Deposited by

Kevin Eady

Requested by Rodger McDonald
Name/Title

Date 2-27-2020

Approved by Kevin Eady
Principal

Date 2/27/2020

Approved by Michelle Gilbert
Director of Schools*

Date 3/9/20

* The Director of Schools must approve all fundraising activities that involve the participation of the general student population in the marketing process of the fundraising effort.

PROPOSED FUNDRAISING ACTIVITIES

Fund/account name HOSA

Proposed fundraising activities: Krispy Kreme Donuts and
Chocolate Bars

Purposed Uses of funds raised
Pay for Regional, State, National Registration
Fees and Hotel Rooms

Expected student involvement (school-wide or specific school organization) _____
HOSA club

Method by which school will receive profit Sales

Requested by Libby Claud
Name/Title

Date 2-26-2020

Approved by Ken D. [Signature]
Principal

Date 2-26-2020

Approved by Michelle Thibert
Director of Schools*

Date 2/28/2020

* The Director of Schools must approve all fundraising activities that involve the participation of the general student population in the marketing process of the fundraising effort.