



# NORTHERN VALLEY SCHOOLS USD 212

DISTRICT OFFICE  
512 WEST BRYANT PO BOX 217  
ALMENA KS 67622



ALMENA

PHONE (785) 669-2445

LONG ISLAND

A Monthly Meeting of the Board of Trustees of Northern Valley Schools was held Monday, July 8, 2024, beginning at 6:30 PM in the Almena High School , 512 W Bryant Street, Almena, KS 67622.

Shanna Hammond: Absent  
Christopher Rogers: Present  
Laquita Smith: Present  
Hilary Van Patten: Present  
Rich Wenzl: Present  
Steven Whitney: Present

Also in attendance were Ken Tharman (HS Principal / Superintendent), Marvin Gebhard (GS/MS Principal), Amber Brown (Board Clerk), and Kenzi Sheley (GS secretary).

I. Call to Order

II. Adoption of Agenda

I recommend the board approve the agenda as presented. This motion, made by Laquita Smith and seconded by Christopher Rogers, Carried.

Shanna Hammond: Absent  
Christopher Rogers: Yea  
Laquita Smith: Yea  
Hilary Van Patten: Yea  
Rich Wenzl: Yea  
Steven Whitney: Yea

Yea: 5, Nay: 0, Absent: 1

III. Approval of Minutes

6

I recommend the board approve the minutes as presented. This motion, made by Steven Whitney and seconded by Rich Wenzl, Carried.

Shanna Hammond: Absent  
Christopher Rogers: Yea  
Laquita Smith: Yea  
Hilary Van Patten: Yea  
Rich Wenzl: Yea  
Steven Whitney: Yea

Yea: 5, Nay: 0, Absent: 1

IV. Approval of Bills

13

I recommend the board approve the bills as presented. This motion, made by Laquita Smith and seconded by Rich Wenzl, Carried.

Shanna Hammond: Absent



# NORTHERN VALLEY SCHOOLS USD 212

DISTRICT OFFICE  
512 WEST BRYANT PO BOX 217  
ALMENA KS 67622



ALMENA

PHONE (785) 669-2445

LONG ISLAND

Hammond:

Christopher      Yea  
Rogers:

Laquita Smith:    Yea

Hilary Van      Yea  
Patten:

Rich Wenzl:      Yea

Steven Whitney:    Yea

Yea: 5, Nay: 0, Absent: 1

V. Hearing of Visitors

The board welcomed Kenzi Sheley.

VI. Old Business

A. Transportation

Mr. Gebhard updated the board on the vehicles. Van #7 is getting a second opinion on the transmission and he and Mr. Tharman are planning to go to Dallas next week to look at a couple of busses. The contractor that had put together a bid for a carport, has since pulled his bid due to health concerns. Mr. Gebhard has continued to look for possible options, one being Viking Steel Structures. I recommend that the board raise the allotted money to \$15,000 to build the shed for the school vehicles. This motion, made by Steven Whitney and seconded by Laquita Smith, Carried.

Shanna

Hammond: Absent

Christopher      Yea  
Rogers:

Laquita      Yea  
Smith:

Hilary Van      Yea  
Patten:

Rich      Yea  
Wenzl:

Steven      Yea  
Whitney:

Yea: 5, Nay: 0, Absent: 1

B. Summer Projects

C. Window Well Covers

44

VII. Personnel

A. Staffing

I recommend the board go into executive session to discuss nonelected personnel matters to protect the privacy interests of the individuals to be discussed, retaining Mr. Gebhard and Mr. Tharman and returning to open session in this room at 7:18 PM. This motion, made by Christopher Rogers and seconded by Steven Whitney, Carried.

Shanna

Hammond: Absent

Christopher      Yea  
Rogers:



# NORTHERN VALLEY SCHOOLS USD 212

DISTRICT OFFICE  
512 WEST BRYANT PO BOX 217  
ALMENA KS 67622



ALMENA

PHONE (785) 669-2445

LONG ISLAND

Laquita Smith: Yea

Hilary Van Patten: Yea

Rich Wenzl: Yea

Steven Whitney: Yea

Yea: 5, Nay: 0, Absent: 1

The meeting returned to open session at 7:18 PM; no action taken.

B. Janitor Position

53

Noah Hansen had requested a move to the GS for janitorial duties; therefore, the open position is the HS janitor. I recommend the board hire Clayson Patterson for the HS janitor position. This motion, made by Rich Wenzl and seconded by Laquita Smith, Carried.

Shanna

Hammond: Absent

Christopher Rogers: Yea

Laquita Smith: Yea

Hilary Van Patten: Yea

Rich Wenzl: Yea

Steven Whitney: Yea

Yea: 5, Nay: 0, Absent: 1

C. Leave Request

56

I recommend the board approve the leave request submitted by Kacie Yocum. This motion, made by Christopher Rogers and seconded by Steven Whitney, Carried.

Shanna

Hammond: Absent

Christopher Rogers: Yea

Laquita Smith: Yea

Hilary Van Patten: Yea

Rich Wenzl: Yea

Steven Whitney: Yea

Yea: 5, Nay: 0, Absent: 1

## VIII. New Business

A. Consent Calendar



# NORTHERN VALLEY SCHOOLS USD 212

DISTRICT OFFICE  
512 WEST BRYANT PO BOX 217  
ALMENA KS 67622



ALMENA

PHONE (785) 669-2445

LONG ISLAND

I recommend the board approve the consent calendar as presented for the 2024 - 25 school year. This motion, made by Steven Whitney and seconded by Christopher Rogers, Carried.

Shanna  
Hammond: Absent

Christopher  
Rogers: Yea

Laquita  
Smith: Yea

Hilary Van  
Patten: Yea

Rich  
Wenzl: Yea

Steven  
Whitney: Yea

Yea: 5, Nay: 0, Absent: 1

B. Appointments: Professional Development, KASB Governmental Relations, Negotiations, and NCKSEC Interlocal #636 Representative.

Those board members currently holding those appointments are: Professional Development - Shanna Hammond / KASB Governmental Relations - Rich Wenzl / Negotiations - Hilary VanPatten & Laquita Smith / and NCKSEC Interlocal #636 Representative - Christopher Rogers. I move that we maintain those members currently assigned for this school year. This motion, made by Laquita Smith and seconded by Steven Whitney, Carried.

Shanna  
Hammond: Absent

Christopher  
Rogers: Yea

Laquita  
Smith: Yea

Hilary Van  
Patten: Yea

Rich  
Wenzl: Yea

Steven  
Whitney: Yea

Yea: 5, Nay: 0, Absent: 1

C. Unencumbered Cash Balances 59

Mr. Tharman briefly went over the unencumbered cash balance report in association with the end-of-the-year transactions.

D. K-12 Handbook 62

I recommend the board approve the K - 12 Handbook as presented. This motion, made by Laquita Smith and seconded by Rich Wenzl, Carried.

Shanna  
Hammond: Absent

Christopher  
Rogers: Yea



# NORTHERN VALLEY SCHOOLS USD 212

DISTRICT OFFICE  
512 WEST BRYANT PO BOX 217  
ALMENA KS 67622



ALMENA

PHONE (785) 669-2445

LONG ISLAND

Laquita Smith: Yea

Hilary Van Patten: Yea

Rich Wenzl: Yea

Steven Whitney: Yea

Yea: 5, Nay: 0, Absent: 1

## IX. Administrative Reports

### A. Superintendent / 9-12 Principal Report

Mr. Tharman reviewed: Roofmasters making good progress on the Long Island roofs and have started working on gutters / Budget has been released and he plans to start on it tomorrow / Defensive Driving on July 23rd / Review of the budget at state will hopefully be either the day prior or after the 23rd / Enrollment will be Aug. 6 & 7 from 8 AM - 4 PM / Teacher Inservice - Aug. 12th / Board meeting - Aug 12th.

### B. K-8 Principal Report

Mr. Gebhard reported that he goes in about twice a week to read emails. He has put together the GS and MS schedules and sent those out for review. He will be gone the first week of August for vacation.

## X. Reports of Board Members

## XI. Adjournment

With no further business, I move the meeting to adjourn. This motion, made by Laquita Smith and seconded by Rich Wenzl, Carried.

Shanna Hammond: Absent

Christopher Rogers: Yea

Laquita Smith: Yea

Hilary Van Patten: Yea

Rich Wenzl: Yea

Steven Whitney: Yea

Yea: 5, Nay: 0, Absent: 1



# NORTHERN VALLEY SCHOOLS USD 212

DISTRICT OFFICE  
512 WEST BRYANT PO BOX 217  
ALMENA KS 67622



ALMENA

PHONE (785) 669-2445

LONG ISLAND

A Monthly Meeting of the Board of Trustees of Northern Valley Schools was held Monday, June 10, 2024, beginning at 6:30 PM in the Long Island Middle School, 627 Washington, Long Island, KS 67647.

Shanna Hammond: Present  
Christopher Rogers: Absent  
Laquita Smith: Present  
Hilary Van Patten: Present  
Rich Wenzl: Present  
Steven Whitney: Absent

Also in attendance were: Ken Tharman (HS Principal and Superintendent), Marvin Gebhard (GS/MS Principal), and Amber Brown (Board Clerk).

## I. Call to Order

## II. Adoption of Agenda

I recommend the board approve the agenda as presented. This motion, made by Shanna Hammond and seconded by Laquita Smith, Carried.

Shanna Hammond: Yea  
Christopher Rogers: Absent  
Laquita Smith: Yea  
Hilary Van Patten: Yea  
Rich Wenzl: Yea  
Steven Whitney: Absent

Yea: 4, Nay: 0, Absent: 2

## III. Approval of Minutes

I recommend the board approve the minutes as presented. This motion, made by Shanna Hammond and seconded by Laquita Smith, Carried.

Shanna Hammond: Yea  
Christopher Rogers: Absent  
Laquita Smith: Yea  
Hilary Van Patten: Yea  
Rich Wenzl: Yea  
Steven Whitney: Absent

Yea: 4, Nay: 0, Absent: 2

## IV. Approval of Bills

I recommend the board approve the bills as presented. This motion, made by Rich Wenzl and seconded by Shanna Hammond, Carried.

Shanna Yea



# NORTHERN VALLEY SCHOOLS USD 212

DISTRICT OFFICE  
512 WEST BRYANT PO BOX 217  
ALMENA KS 67622



ALMENA

PHONE (785) 669-2445

LONG ISLAND

Hammond:

Christopher Rogers: Absent

Laquita Smith: Yea

Hilary Van Patten: Yea

Rich Wenzl: Yea

Steven Whitney: Absent

Yea: 4, Nay: 0, Absent: 2

V. Hearing of Visitors

VI. Old Business

A. Hail Damage Update

Mr. Tharman gave the following update: Roofmasters to begin on either June 20th or the 24th in Long Island ... and then work their way to Almena Ag building/ Vehicle checks (for totaled value due to hail) have arrived and been deposited/ Still waiting on two classroom windows to be installed/ Hallway and Ag shop windows are installed/ Out buildings' tin work is being ordered/ Car port building has been okayed and materials are being ordered.

B. Transportation

Mr. Gebhard shared that all buses have been checked in by drivers. Van #7 was reported to have transmission issues .... will be taking it for a second opinion. Bus #12 will be going to have catalytic converter repaired. Mr. Gebhard shared information he had received concerning three different buses that met the criteria he was looking for as well as specifications he had asked local mechanics about. In order to get a better look, he and Mr. Tharman plan to make a trip to look those over.

C. Legislative Update

Mr. Tharman gave the following updates:

Senate Bill 19 - Cardiac Emergency Response Plans - a adopt a comprehensive cardiac emergency response plan, including policies and procedures for cardiac emergency responses for each attendance center. (no timeline as of yet)

Senate Bill 73 - Enrollment for the Determination of State Aid - includes a one-year provision to allow school districts and KSDE to use the highest of the current year, prior year, or the arithmetic average of the preceding and second preceding year enrollment for the school year 2024 - 25 only. In 2025 - 26 and each year after, all districts will be required to use the current year or the preceding year enrollment to determine state aid.

Senate Bill 287 - Parental Consent for Healthcare Services in School Facilities - The bill prohibits a health provider at a school facility from prescribing, dispensing or administering any prescription or nonprescription drug, administering a diagnostic test with the minor's bodily fluid, or conducting ongoing behavioral health treatment, unless a health care provider has obtained consent from a minor's parent.

Senate Bill 387 - K-12 Education Appropriations and other provisions - School funding for FY 2024, 2025, 2026 / Assigns an education funding task force to rework the funding formula and who makes up that committee/ Special Education distribution of funds and determining excess costs and state aid / At - Risk monies, how they are spent and reported/ open enrollment provisions - in 2025 it will be open from Jan. 1st - Jun 15th. / Closing school building procedures.

House Sub for Senate Bill 438 - Blueprint for Literacy and Scholarship programs - Gives colleges guidelines for those in education programs to receive the required classes and training during their post-secondary experience prior to graduating. (LTR's)

Senate Sub for House Bill 2144 - Creating the Crime of Encouraging Suicide - establishes penalties for it under the Kansas Criminal Code.

House Bill 2547 - Emergency Medication Kits - authorizes a school to maintain a stock supply of emergency medication kits in schools, including epinephrine and albuterol for certain life - threatening



# NORTHERN VALLEY SCHOOLS USD 212

DISTRICT OFFICE  
512 WEST BRYANT PO BOX 217  
ALMENA KS 67622



ALMENA

PHONE (785) 669-2445

LONG ISLAND

conditions.

## VII. Personnel

### A. Staffing

I recommend the board go into executive session to discuss nonelected personnel matters to protect the privacy interests of the individuals to be discussed; retaining Mr. Gebhard and Mr. Tharman and returning to open session in this room at 7:25 PM. This motion, made by Laquita Smith and seconded by Shanna Hammond, Carried.

Shanna

Hammond: Yea

Christopher

Rogers: Absent

Laquita

Smith: Yea

Hilary Van

Patten: Yea

Rich

Wenzl: Yea

Steven

Whitney: Absent

Yea: 4, Nay: 0, Absent: 2

### B. Resignations

I recommend the board approve the HS Scholars Bowl and Pre-School Bus Driver resignations as presented. This motion, made by Shanna Hammond and seconded by Laquita Smith, Carried.

Shanna

Hammond: Yea

Christopher

Rogers: Absent

Laquita

Smith: Yea

Hilary Van

Patten: Yea

Rich

Wenzl: Yea

Steven

Whitney: Absent

Yea: 4, Nay: 0, Absent: 2

### C. Maintenance Position

I recommend the board hire Dean Lewis for the maintenance position. This motion, made by Shanna Hammond and seconded by Rich Wenzl, Carried.

Shanna

Hammond: Yea

Christopher

Rogers: Absent



# NORTHERN VALLEY SCHOOLS USD 212

DISTRICT OFFICE  
512 WEST BRYANT PO BOX 217  
ALMENA KS 67622



ALMENA

PHONE (785) 669-2445

LONG ISLAND

Laquita Smith: Yea

Hilary Van Patten: Yea

Rich Wenzl: Yea

Steven Whitney: Absent

Yea: 4, Nay: 0, Absent: 2

## VIII. New Business

### A. Summer Helpers and Projects

I recommend the board hire Andrea Schurman as a summer helper. This motion, made by Laquita Smith and seconded by Shanna Hammond, Carried.

Shanna Hammond: Yea

Christopher Rogers: Absent

Laquita Smith: Yea

Hilary Van Patten: Yea

Rich Wenzl: Yea

Steven Whitney: Absent

Yea: 4, Nay: 0, Absent: 2

Mr. Tharman shared a list of proposed projects and tasks the summer employees were working on.

### B. KASB Policy Updates

Mr. Tharman briefly went over the amended JBCC KASB policy as well as the June KASB policy updates. I recommend the board approve the June KASB Policy Updates as presented and amend the JBCC policy to be updated with the new language presented by KASB. This motion, made by Shanna Hammond and seconded by Rich Wenzl, Carried.

Shanna Hammond: Yea

Christopher Rogers: Absent

Laquita Smith: Yea

Hilary Van Patten: Yea

Rich Wenzl: Yea

Steven Whitney: Absent

Yea: 4, Nay: 0, Absent: 2



# NORTHERN VALLEY SCHOOLS USD 212

DISTRICT OFFICE  
512 WEST BRYANT PO BOX 217  
ALMENA KS 67622



ALMENA

PHONE (785) 669-2445

LONG ISLAND

## C. Student Accident Insurance

I recommend the board approve the Student Accident Insurance Policy renewal quote from 1st Agency as presented. This motion, made by Shanna Hammond and seconded by Laquita Smith, Carried.

Shanna  
Hammond: Yea

Christopher  
Rogers: Absent

Laquita  
Smith: Yea

Hilary Van  
Patten: Yea

Rich  
Wenzl: Yea

Steven  
Whitney: Absent

Yea: 4, Nay: 0, Absent: 2

## D. Workman's Compensation Insurance

I recommend the board approve the workmen's comp renewal quote from First Dakota Indemnity as presented. This motion, made by Rich Wenzl and seconded by Shanna Hammond, Carried.

Shanna  
Hammond: Yea

Christopher  
Rogers: Absent

Laquita  
Smith: Yea

Hilary Van  
Patten: Yea

Rich  
Wenzl: Yea

Steven  
Whitney: Absent

Yea: 4, Nay: 0, Absent: 2

## E. Property and Liability Insurance

I recommend the board approve the Property and Liability renewal quote from Kansas Insurance Cooperatives for Schools (old KERMP) as presented. This motion, made by Laquita Smith and seconded by Rich Wenzl, Carried.

Shanna  
Hammond: Yea

Christopher  
Rogers: Absent

Laquita  
Smith: Yea

Hilary Van Yea



# NORTHERN VALLEY SCHOOLS USD 212

DISTRICT OFFICE  
512 WEST BRYANT PO BOX 217  
ALMENA KS 67622



ALMENA

PHONE (785) 669-2445

LONG ISLAND

Patten:

Rich Wenzl: Yea

Steven Whitney: Absent

Yea: 4, Nay: 0, Absent: 2

### F. Resolution to Destroy Documents

Amber went over the proposed documents to destroy. I recommend the board approve the list of Employee and Bookkeeping records listed to be shredded. This motion, made by Laquita Smith and seconded by Shanna Hammond, Carried.

Shanna Hammond: Yea

Christopher Rogers: Absent

Laquita Smith: Yea

Hilary Van Patten: Yea

Rich Wenzl: Yea

Steven Whitney: Absent

Yea: 4, Nay: 0, Absent: 2

### G. End of the Fiscal Year Meeting

I recommend the board approve Mr. Tharman and Amber to make the necessary end-of-the-year transfers without a special board meeting. This motion, made by Rich Wenzl and seconded by Shanna Hammond, Carried.

Shanna Hammond: Yea

Christopher Rogers: Absent

Laquita Smith: Yea

Hilary Van Patten: Yea

Rich Wenzl: Yea

Steven Whitney: Absent

Yea: 4, Nay: 0, Absent: 2

## IX. Administrative Reports

### A. Superintendent / 9-12 Principal Report

Mr. Tharman reviewed the personal items that have been going on in his world. He also shared about the next 6 - 8 weeks and what that would possibly look like. Mr. Tharman passed around Thank You cards from Mrs. Dole and Mrs. Vincent.



# NORTHERN VALLEY SCHOOLS USD 212

DISTRICT OFFICE  
512 WEST BRYANT PO BOX 217  
ALMENA KS 67622



ALMENA

PHONE (785) 669-2445

LONG ISLAND

Summer volleyball, cheer/dance, and basketball camps/games are currently going on, as well as weightlifting.

### B. K-8 Principal Report

Mr. Gebhard shared about a donation of over \$400 from Land O' Lakes; it was greatly appreciated. The May in-service went very well and was attended by all of the new hires except one (had a prior commitment). State assessment scores had been released, so he passed around an overview of those for each grade level and discussed, briefly.

### X. Reports of Board Members

### XI. Adjournment

I recommend the board adjourn. This motion, made by Shanna Hammond and seconded by Laquita Smith, Carried.

- Shanna Hammond: Yea
- Christopher Rogers: Absent
- Laquita Smith: Yea
- Hilary Van Patten: Yea
- Rich Wenzl: Yea
- Steven Whitney: Absent

Yea: 4, Nay: 0, Absent: 2

# USD 212

## Check Listing Report

Accounting Cycle: FY 23-24; Begin Date: 06/17/2024; End Date: 07/04/2024; Bank: First National Bank & Trust; Sort By Element: FUND; Account Expression: [All]; Created On: 7/4/2024

Voucher Number	Bank Name	Account Number	Check Number
Bills For 6/18/2024	First National Bank & Trust	003174	65672
Vendor	PO Number	Invoice #	Account Code
City Of Long Island	23-3455	Bills For 6/18/2024	08-2600-411-03-00
City Of Long Island	23-3455	Bills For 6/18/2024	08-2600-412-03-00
City Of Long Island	23-3455	Bills For 6/18/2024	08-2600-421-03-00
<b>Sub Total</b>			
Voucher Number	Bank Name	Account Number	Check Number
Bills For 6/18/2024	First National Bank & Trust	003174	65673
Vendor	PO Number	Invoice #	Account Code
Midwest Energy	23-3454	Bills For 6/18/2024	06-2600-621-01-00
Midwest Energy	23-3454	Bills For 6/18/2024	06-2600-621-02-00
Midwest Energy	23-3454	Bills For 6/18/2024	06-2600-621-03-00
Midwest Energy	23-3454	Bills For 6/18/2024	34-2600-621-00-00
<b>Sub Total</b>			
Voucher Number	Bank Name	Account Number	Check Number
Bills For 6/18/2024	First National Bank & Trust	003174	65674
Vendor	PO Number	Invoice #	Account Code
Risk Administration Services, Inc.	23-3452	Bills For 6/18/2024	08-2300-522-00-00
<b>Sub Total</b>			
Voucher Number	Bank Name	Account Number	Check Number
Bills For 6/18/2024	First National Bank & Trust	003174	65675
Vendor	PO Number	Invoice #	Account Code
Smoky Hill - USD 629	23-3453	Bills For 6/18/2024	06-1000-610-01-05
<b>Sub Total</b>			
Voucher Number	Bank Name	Account Number	Check Number
Reimburse Senior Class of 2024	First National Bank & Trust	003174	65676
Vendor	PO Number	Invoice #	Account Code
Northern Valley	23-3456	Reimburse Senior Class of 2024	06-1000-610-01-11
<b>Sub Total</b>			
Voucher Number	Bank Name	Account Number	Check Number
Bills For End of FY 1	First National Bank & Trust	003174	65677

<b>Vendor</b>	<b>PO Number</b>	<b>Invoice #</b>	<b>Account Code</b>
AFPLANSERV	23-3466	Bills For End of FY 1	06-2300-300-00-00
<b>Sub Total</b>			
<b>Voucher Number</b>	<b>Bank Name</b>	<b>Account Number</b>	<b>Check Number</b>
Bills For End of FY 1	First National Bank & Trust	003174	65678
<b>Vendor</b>	<b>PO Number</b>	<b>Invoice #</b>	<b>Account Code</b>
Dalrymple Environmental Inc.	23-3465	Bills For End of FY 1	16-2600-300-00-00
<b>Sub Total</b>			
<b>Voucher Number</b>	<b>Bank Name</b>	<b>Account Number</b>	<b>Check Number</b>
Bills For End of FY 1	First National Bank & Trust	003174	65679
<b>Vendor</b>	<b>PO Number</b>	<b>Invoice #</b>	<b>Account Code</b>
Dealers First Financial L.L.C.	23-3464	Bills For End of FY 1	16-1000-700-01-00
Dealers First Financial L.L.C.	23-3464	Bills For End of FY 1	16-1000-700-02-00
Dealers First Financial L.L.C.	23-3464	Bills For End of FY 1	16-1000-700-03-00
<b>Sub Total</b>			
<b>Voucher Number</b>	<b>Bank Name</b>	<b>Account Number</b>	<b>Check Number</b>
Bills For End of FY 1	First National Bank & Trust	003174	65680
<b>Vendor</b>	<b>PO Number</b>	<b>Invoice #</b>	<b>Account Code</b>
Emily Lowry	23-3462	Bills For End of FY 1	26-2200-502-00-00
<b>Sub Total</b>			
<b>Voucher Number</b>	<b>Bank Name</b>	<b>Account Number</b>	<b>Check Number</b>
Bills For End of FY 1	First National Bank & Trust	003174	65681
<b>Vendor</b>	<b>PO Number</b>	<b>Invoice #</b>	<b>Account Code</b>
Hinklel Termite and Pest Control	23-3463	Bills For End of FY 1	08-2600-425-00-00
<b>Sub Total</b>			
<b>Voucher Number</b>	<b>Bank Name</b>	<b>Account Number</b>	<b>Check Number</b>
Bills For End of FY 1	First National Bank & Trust	003174	65682
<b>Vendor</b>	<b>PO Number</b>	<b>Invoice #</b>	<b>Account Code</b>
Hop-A-Long IT Services	23-3458	Bills For End of FY 1	08-1000-300-00-00
<b>Sub Total</b>			
<b>Voucher Number</b>	<b>Bank Name</b>	<b>Account Number</b>	<b>Check Number</b>
Bills For End of FY 1	First National Bank & Trust	003174	65683
<b>Vendor</b>	<b>PO Number</b>	<b>Invoice #</b>	<b>Account Code</b>
Jostens (JOSTES)	23-3459	Bills For End of FY 1	06-1000-610-03-09
<b>Sub Total</b>			
<b>Voucher Number</b>	<b>Bank Name</b>	<b>Account Number</b>	<b>Check Number</b>
Bills For End of FY 1	First National Bank & Trust	003174	65684

<b>Vendor</b>	<b>PO Number</b>	<b>Invoice #</b>	<b>Account Code</b>
KSHSAA	23-3457	Bills For End of FY 1	06-1000-890-03-09
<b>Sub Total</b>			
<b>Voucher Number</b>	<b>Bank Name</b>	<b>Account Number</b>	<b>Check Number</b>
Bills For End of FY 1	First National Bank & Trust	003174	65685
<b>Vendor</b>	<b>PO Number</b>	<b>Invoice #</b>	<b>Account Code</b>
Nex-Tech Wireless, LLC	23-3468	Bills For End of FY 1	06-2720-890-00-17
<b>Sub Total</b>			
<b>Voucher Number</b>	<b>Bank Name</b>	<b>Account Number</b>	<b>Check Number</b>
Bills For End of FY 1	First National Bank & Trust	003174	65686
<b>Vendor</b>	<b>PO Number</b>	<b>Invoice #</b>	<b>Account Code</b>
Phillips County Review	23-3461	Bills For End of FY 1	06-2300-590-00-02
<b>Sub Total</b>			
<b>Voucher Number</b>	<b>Bank Name</b>	<b>Account Number</b>	<b>Check Number</b>
Bills For End of FY 1	First National Bank & Trust	003174	65687
<b>Vendor</b>	<b>PO Number</b>	<b>Invoice #</b>	<b>Account Code</b>
Renaissance	23-3467	Bills For End of FY 1	06-1000-590-00-00
<b>Sub Total</b>			
<b>Voucher Number</b>	<b>Bank Name</b>	<b>Account Number</b>	<b>Check Number</b>
Bills For End of FY 1	First National Bank & Trust	003174	65688
<b>Vendor</b>	<b>PO Number</b>	<b>Invoice #</b>	<b>Account Code</b>
Sawyer's Ace Hardware	23-3460	Bills For End of FY 1	08-2600-400-00-01
<b>Sub Total</b>			
<b>Voucher Number</b>	<b>Bank Name</b>	<b>Account Number</b>	<b>Check Number</b>
Hop a long payment for July 2024	First National Bank & Trust	003174	65690
<b>Vendor</b>	<b>PO Number</b>	<b>Invoice #</b>	<b>Account Code</b>
Hop-A-Long IT Services	23-3469	Hop a Long July Payment	07-2100-120-00-00
<b>Sub Total</b>			
<b>Voucher Number</b>	<b>Bank Name</b>	<b>Account Number</b>	<b>Check Number</b>
Bills for end of FY 2023-2024	First National Bank & Trust	003174	65709
<b>Vendor</b>	<b>PO Number</b>	<b>Invoice #</b>	<b>Account Code</b>
First National Bank & Trust	23-3472	Bills for end of FY 2023-2024	16-4700-450-03-00
First National Bank & Trust	23-3472	Bills for end of FY 2023-2024	35-4700-450-01-00
<b>Sub Total</b>			
<b>Voucher Number</b>	<b>Bank Name</b>	<b>Account Number</b>	<b>Check Number</b>
Bills for end of FY 2023-2024	First National Bank & Trust	003174	65710
<b>Vendor</b>	<b>PO Number</b>	<b>Invoice #</b>	<b>Account Code</b>

KICS	23-3474	Bills for end of FY 2023-2024	08-2200-300-00-00
<b>Sub Total</b>			
<b>Voucher Number</b>	<b>Bank Name</b>	<b>Account Number</b>	<b>Check Number</b>
Bills for end of FY 2023-2024	First National Bank & Trust	003174	65711
<b>Vendor</b>	<b>PO Number</b>	<b>Invoice #</b>	<b>Account Code</b>
Nickell Concrete	23-3470	Bills for end of FY 2023-2024	08-2600-400-00-01
<b>Sub Total</b>			
<b>Voucher Number</b>	<b>Bank Name</b>	<b>Account Number</b>	<b>Check Number</b>
Bills for end of FY 2023-2024	First National Bank & Trust	003174	65712
<b>Vendor</b>	<b>PO Number</b>	<b>Invoice #</b>	<b>Account Code</b>
Power Washing Plus L.L.C.	23-3471	Bills for end of FY 2023-2024	08-2600-400-00-01
Power Washing Plus L.L.C.	23-3471	Bills for end of FY 2023-2024	08-2600-400-00-02
<b>Sub Total</b>			
<b>Voucher Number</b>	<b>Bank Name</b>	<b>Account Number</b>	<b>Check Number</b>
Bills for end of FY 2023-2024	First National Bank & Trust	003174	65713
<b>Vendor</b>	<b>PO Number</b>	<b>Invoice #</b>	<b>Account Code</b>
Pur-O-Zone	23-3473	Bills for end of FY 2023-2024	08-2600-700-00-01
<b>Sub Total</b>			
<b>Grand Total</b>			

024 12:45:24 PM

Payee	Amount	Type
City Of Long Island	\$224.92	Accounts Payable
Description	Issue Date	Amount
City bill	06/18/2024	\$162.00
City bill	06/18/2024	\$41.92
City bill	06/18/2024	\$21.00
		<b>\$224.92</b>
Payee	Amount	Type
Midwest Energy	\$1,036.39	Accounts Payable
Description	Issue Date	Amount
Bill	06/18/2024	\$211.58
Bill	06/18/2024	\$314.31
Bill	06/18/2024	\$203.84
Bill	06/18/2024	\$306.66
		<b>\$1,036.39</b>
Payee	Amount	Type
Risk Administration Services, Inc.	\$13,619.00	Accounts Payable
Description	Issue Date	Amount
Invoice: 3734423	06/18/2024	\$13,619.00
		<b>\$13,619.00</b>
Payee	Amount	Type
Smoky Hill - USD 629	\$244.72	Accounts Payable
Description	Issue Date	Amount
01733	06/18/2024	\$244.72
		<b>\$244.72</b>
Payee	Amount	Type
Northern Valley	\$219.42	Accounts Payable
Description	Issue Date	Amount
Reimbursement	06/19/2024	\$219.42
		<b>\$219.42</b>
Payee	Amount	Type
AFPLANSERV	\$15.00	Accounts Payable

Description	Issue Date	Amount
Invoice Number: 24053163020	06/26/2024	\$15.00
		<b>\$15.00</b>
Payee	Amount	Type
Dalrymple Environmental Inc.	\$900.00	Accounts Payable
Description	Issue Date	Amount
Invoice Number: 2746	06/26/2024	\$900.00
		<b>\$900.00</b>
Payee	Amount	Type
Dealers First Financial L.L.C.	\$885.00	Accounts Payable
Description	Issue Date	Amount
Invoice Numbers: 190779, 190649, and 190650	06/26/2024	\$295.00
Invoice Numbers: 190779, 190649, and 190650	06/26/2024	\$460.00
Invoice Numbers: 190779, 190649, and 190650	06/26/2024	\$130.00
		<b>\$885.00</b>
Payee	Amount	Type
Emily Lowry	\$30.00	Accounts Payable
Description	Issue Date	Amount
Meal Allowance	06/26/2024	\$30.00
		<b>\$30.00</b>
Payee	Amount	Type
Hinklel Termite and Pest Control	\$29.66	Accounts Payable
Description	Issue Date	Amount
Invoice Number: 43056	06/26/2024	\$29.66
		<b>\$29.66</b>
Payee	Amount	Type
Hop-A-Long IT Services	\$869.96	Accounts Payable
Description	Issue Date	Amount
Invoice Numbers: 2250, 2329, and 2894	06/26/2024	\$869.96
		<b>\$869.96</b>
Payee	Amount	Type
Jostens (JOSTES)	\$18.88	Accounts Payable
Description	Issue Date	Amount
Invoice Number: 33745488	06/26/2024	\$18.88
		<b>\$18.88</b>
Payee	Amount	Type
KSHSAA	\$200.00	Accounts Payable

Description	Issue Date	Amount
invoice Number- 24-7584	06/26/2024	\$200.00
		<b>\$200.00</b>
Payee	Amount	Type
Nex-Tech Wireless, LLC	\$108.98	Accounts Payable
Description	Issue Date	Amount
Invoice Number 10455179	06/26/2024	\$108.98
		<b>\$108.98</b>
Payee	Amount	Type
Phillips County Review	\$88.40	Accounts Payable
Description	Issue Date	Amount
Invoice Number: 120195	06/26/2024	\$88.40
		<b>\$88.40</b>
Payee	Amount	Type
Renaissance	\$2,953.37	Accounts Payable
Description	Issue Date	Amount
Invoice Number: 5326257	06/26/2024	\$2,953.37
		<b>\$2,953.37</b>
Payee	Amount	Type
Sawyer's Ace Hardware	\$597.23	Accounts Payable
Description	Issue Date	Amount
Invoice Number: 150281	06/26/2024	\$597.23
		<b>\$597.23</b>
Payee	Amount	Type
Hop-A-Long IT Services	\$7,000.00	Accounts Payable
Description	Issue Date	Amount
Invoice Number 2303	06/26/2024	\$7,000.00
		<b>\$7,000.00</b>
Payee	Amount	Type
First National Bank & Trust	\$43,159.12	Accounts Payable
Description	Issue Date	Amount
Lease Purchase Agreement	06/28/2024	\$28,159.12
Lease Purchase Agreement	06/28/2024	\$15,000.00
		<b>\$43,159.12</b>
Payee	Amount	Type
KICS	\$83,943.06	Accounts Payable
Description	Issue Date	Amount

Kansas Educational Risk Management Pool, LLC	06/28/2024	\$83,943.06
		<b>\$83,943.06</b>
<b>Payee</b>	<b>Amount</b>	<b>Type</b>
Nickell Concrete	\$5,000.00	Accounts Payable
<b>Description</b>	<b>Issue Date</b>	<b>Amount</b>
Invoice: 745044	06/28/2024	\$5,000.00
		<b>\$5,000.00</b>
<b>Payee</b>	<b>Amount</b>	<b>Type</b>
Power Washing Plus L.L.C.	\$900.00	Accounts Payable
<b>Description</b>	<b>Issue Date</b>	<b>Amount</b>
Hoods Cleaned	06/28/2024	\$600.00
Hoods Cleaned	06/28/2024	\$300.00
		<b>\$900.00</b>
<b>Payee</b>	<b>Amount</b>	<b>Type</b>
Pur-O-Zone	\$1,108.43	Accounts Payable
<b>Description</b>	<b>Issue Date</b>	<b>Amount</b>
Invoice: 896949	06/28/2024	\$1,108.43
		<b>\$1,108.43</b>
		<b>\$163,151.54</b>

# USD 212

## Check Listing Report

Accounting Cycle: FY 23-24; Begin Date: 06/17/2024; End Date: 07/04/2024; Bank: First National Bank & Trust; Sort By Element: FUND; Account Expression: [All]; Created On: 7/4/2024 12:45:24 PM

Check Date	Check Number	Payee	Type	Amount
06/18/2024	65672	City Of Long Island	Accounts Payable	\$224.92
06/18/2024	65673	Midwest Energy	Accounts Payable	\$1,036.39
06/18/2024	65674	Risk Administration Services, Inc.	Accounts Payable	\$13,619.00
06/18/2024	65675	Smoky Hill - USD 629	Accounts Payable	\$244.72
06/19/2024	65676	Northern Valley	Accounts Payable	\$219.42
06/26/2024	65677	AFPLANSERV	Accounts Payable	\$15.00
06/26/2024	65678	Dalrymple Environmental Inc.	Accounts Payable	\$900.00
06/26/2024	65679	Dealers First Financial L.L.C.	Accounts Payable	\$885.00
06/26/2024	65680	Emily Lowry	Accounts Payable	\$30.00
06/26/2024	65681	Hinklel Termite and Pest Control	Accounts Payable	\$29.66
06/26/2024	65682	Hop-A-Long IT Services	Accounts Payable	\$869.96
06/26/2024	65683	Jostens (JOSTES)	Accounts Payable	\$18.88
06/26/2024	65684	KSHSAA	Accounts Payable	\$200.00
06/26/2024	65685	Nex-Tech Wireless, LLC	Accounts Payable	\$108.98
06/26/2024	65686	Phillips County Review	Accounts Payable	\$88.40
06/26/2024	65687	Renaissance	Accounts Payable	\$2,953.37
06/26/2024	65688	Sawyer's Ace Hardware	Accounts Payable	\$597.23
06/26/2024	65690	Hop-A-Long IT Services	Accounts Payable	\$7,000.00
06/28/2024	65709	First National Bank & Trust	Accounts Payable	\$43,159.12
06/28/2024	65710	KICS	Accounts Payable	\$83,943.06
06/28/2024	65711	Nickell Concrete	Accounts Payable	\$5,000.00
06/28/2024	65712	Power Washing Plus L.L.C.	Accounts Payable	\$900.00
06/28/2024	65713	Pur-O-Zone	Accounts Payable	\$1,108.43
<b>Sub Total</b>				<b>\$163,151.54</b>

# USD 212

## Check Listing Report

Accounting Cycle: FY 23-24; Begin Date: 06/17/2024; End Date: 07/04/2024; Bank: First National Bank & Trust; Sort By Element: FUND; Account Expression: [All]; Created On: 7/4/20

Check Date	Check Number	Payee	Description	Type
06/26/2024	65677	AFPLANSERV	Invoice; 24053163020	Accounts Payable
06/18/2024	65672	City Of Long Island	Inv: Bills For 6/18/2024	Accounts Payable
06/26/2024	65678	Dalrymple Environmental Inc.	Invoice Number: 2746	Accounts Payable
06/26/2024	65679	Dealers First Financial L.L.C.	Invoice Numbers: 190779, 190649, and 190650	Accounts Payable
06/26/2024	65680	Emily Lowry	Inv: Bills For End of FY 1	Accounts Payable
06/28/2024	65709	First National Bank & Trust	Lease Purchase Agreement wrote 6/28/2024	Accounts Payable
06/26/2024	65681	Hinklel Termite and Pest Control	invoice: 43056	Accounts Payable
06/26/2024	65682	Hop-A-Long IT Services	Invoice Numbers: 2250,2329, and 2894	Accounts Payable
06/26/2024	65690	Hop-A-Long IT Services	Hop a Long July Payment	Accounts Payable
06/26/2024	65683	Jostens (JOSTES)	Invoice: 33745488	Accounts Payable
06/28/2024	65710	KICS	Inv: Bills for end of FY 2023-2024	Accounts Payable
06/26/2024	65684	KSHSAA	Invoice Number: 24-7584	Accounts Payable
06/18/2024	65673	Midwest Energy	Inv: Bills For 6/18/2024	Accounts Payable
06/26/2024	65685	Nex-Tech Wireless, LLC	Invoice Number 10455179	Accounts Payable
06/28/2024	65711	Nickell Concrete	Invoice: 745044	Accounts Payable
06/19/2024	65676	Northern Valley	Reimburse Senior Class of 2024	Accounts Payable
06/26/2024	65686	Phillips County Review	Invoice: 120195	Accounts Payable
06/28/2024	65712	Power Washing Plus L.L.C.	Hoods Cleaned	Accounts Payable
06/28/2024	65713	Pur-O-Zone	Invoice: 896949	Accounts Payable
06/26/2024	65687	Renaissance	Invoice Number: 5326257	Accounts Payable
06/18/2024	65674	Risk Administration Services, Inc.	Inv: Bills For 6/18/2024	Accounts Payable
06/26/2024	65688	Sawyer's Ace Hardware	Invoice: 150281	Accounts Payable
06/18/2024	65675	Smoky Hill - USD 629	Inv: Bills For 6/18/2024	Accounts Payable
<b>Sub Total</b>				

12/24 12:45:24 PM

Amount
\$15.00
\$224.92
\$900.00
\$885.00
\$30.00
\$43,159.12
\$29.66
\$869.96
\$7,000.00
\$18.88
\$83,943.06
\$200.00
\$1,036.39
\$108.98
\$5,000.00
\$219.42
\$88.40
\$900.00
\$1,108.43
\$2,953.37
\$13,619.00
\$597.23
\$244.72
<b>\$163,151.54</b>

# USD 212

## Check Listing Report

Accounting Cycle: FY 24-25; Begin Date: 07/01/2024; End Date: 07/08/2024; Bank: First National Bank & Trust; Sort By Element: FUND; Account Expression: [All]; Created

Voucher Number	Bank Name	Account Number	Check Number
July 2024 Bills	First National Bank & Trust	003174	65714
Vendor	PO Number	Invoice #	Account Code
Advocate Of Phillips Co., The	23-3487	July 2024 Bills	06-2300-590-00-02
<b>Sub Total</b>			
Voucher Number	Bank Name	Account Number	Check Number
July 2024 Bills	First National Bank & Trust	003174	65715
Vendor	PO Number	Invoice #	Account Code
Andrew Sheley	23-3477	July 2024 Bills	08-2600-400-00-01
<b>Sub Total</b>			
Voucher Number	Bank Name	Account Number	Check Number
July 2024 Bills	First National Bank & Trust	003174	65716
Vendor	PO Number	Invoice #	Account Code
Austyn Cox	23-3499	July 2024 Bills	35-1000-610-01-10
Austyn Cox	23-3499	July 2024 Bills	35-1000-610-01-10
<b>Sub Total</b>			
Voucher Number	Bank Name	Account Number	Check Number
July 2024 Bills	First National Bank & Trust	003174	65717
Vendor	PO Number	Invoice #	Account Code
Braxton Cox	23-3491	July 2024 Bills	35-1000-610-01-04
<b>Sub Total</b>			
Voucher Number	Bank Name	Account Number	Check Number
July 2024 Bills	First National Bank & Trust	003174	65718
Vendor	PO Number	Invoice #	Account Code
Chris Cochran	23-3475	July 2024 Bills	06-2300-890-00-00
<b>Sub Total</b>			
Voucher Number	Bank Name	Account Number	Check Number
July 2024 Bills	First National Bank & Trust	003174	65719
Vendor	PO Number	Invoice #	Account Code
City Of Almena	23-3481	July 2024 Bills	08-2600-411-01-00
City Of Almena	23-3481	July 2024 Bills	08-2600-411-02-00
City Of Almena	23-3481	July 2024 Bills	08-2600-412-01-00

City Of Almena	23-3481	July 2024 Bills	08-2600-412-02-00
City Of Almena	23-3481	July 2024 Bills	08-2600-421-01-00
City Of Almena	23-3481	July 2024 Bills	34-2600-411-00-00
<b>Sub Total</b>			
<b>Voucher Number</b>	<b>Bank Name</b>	<b>Account Number</b>	<b>Check Number</b>
July 2024 Bills	First National Bank & Trust	003174	65720
<b>Vendor</b>	<b>PO Number</b>	<b>Invoice #</b>	<b>Account Code</b>
ComplianceOne	23-3476	July 2024 Bills	06-2720-890-00-17
<b>Sub Total</b>			
<b>Voucher Number</b>	<b>Bank Name</b>	<b>Account Number</b>	<b>Check Number</b>
July 2024 Bills	First National Bank & Trust	003174	65721
<b>Vendor</b>	<b>PO Number</b>	<b>Invoice #</b>	<b>Account Code</b>
Daynah Bailey	23-3496	July 2024 Bills	35-1000-610-01-04
<b>Sub Total</b>			
<b>Voucher Number</b>	<b>Bank Name</b>	<b>Account Number</b>	<b>Check Number</b>
July 2024 Bills	First National Bank & Trust	003174	65722
<b>Vendor</b>	<b>PO Number</b>	<b>Invoice #</b>	<b>Account Code</b>
Farmhouse Kitchen & Katering LLC	23-3500	July 2024 Bills	26-2200-502-00-00
<b>Sub Total</b>			
<b>Voucher Number</b>	<b>Bank Name</b>	<b>Account Number</b>	<b>Check Number</b>
July 2024 Bills	First National Bank & Trust	003174	65723
<b>Vendor</b>	<b>PO Number</b>	<b>Invoice #</b>	<b>Account Code</b>
Gabriel Rudd	23-3495	July 2024 Bills	35-1000-610-01-04
<b>Sub Total</b>			
<b>Voucher Number</b>	<b>Bank Name</b>	<b>Account Number</b>	<b>Check Number</b>
July 2024 Bills	First National Bank & Trust	003174	65724
<b>Vendor</b>	<b>PO Number</b>	<b>Invoice #</b>	<b>Account Code</b>
HTMC	23-3486	July 2024 Bills	06-2300-590-00-02
<b>Sub Total</b>			
<b>Voucher Number</b>	<b>Bank Name</b>	<b>Account Number</b>	<b>Check Number</b>
July 2024 Bills	First National Bank & Trust	003174	65725
<b>Vendor</b>	<b>PO Number</b>	<b>Invoice #</b>	<b>Account Code</b>
Iron Insurance Partners	23-3482	July 2024 Bills	08-2300-522-00-00
<b>Sub Total</b>			
<b>Voucher Number</b>	<b>Bank Name</b>	<b>Account Number</b>	<b>Check Number</b>
July 2024 Bills	First National Bank & Trust	003174	65726
<b>Vendor</b>	<b>PO Number</b>	<b>Invoice #</b>	<b>Account Code</b>

Jeremiah Hansen	23-3497	July 2024 Bills	35-1000-610-01-04
<b>Sub Total</b>			
<b>Voucher Number</b> July 2024 Bills	<b>Bank Name</b> First National Bank & Trust	<b>Account Number</b> 003174	<b>Check Number</b> 65727
<b>Vendor</b> Kenton Thalheim	<b>PO Number</b> 23-3493	<b>Invoice #</b> July 2024 Bills	<b>Account Code</b> 35-1000-610-01-04
<b>Sub Total</b>			
<b>Voucher Number</b> July 2024 Bills	<b>Bank Name</b> First National Bank & Trust	<b>Account Number</b> 003174	<b>Check Number</b> 65728
<b>Vendor</b> Kowpoke Supply	<b>PO Number</b> 23-3483	<b>Invoice #</b> July 2024 Bills	<b>Account Code</b> 08-2600-400-00-01
<b>Sub Total</b>			
<b>Voucher Number</b> July 2024 Bills	<b>Bank Name</b> First National Bank & Trust	<b>Account Number</b> 003174	<b>Check Number</b> 65729
<b>Vendor</b> Mary Baird	<b>PO Number</b> 23-3492	<b>Invoice #</b> July 2024 Bills	<b>Account Code</b> 35-1000-610-01-04
<b>Sub Total</b>			
<b>Voucher Number</b> July 2024 Bills	<b>Bank Name</b> First National Bank & Trust	<b>Account Number</b> 003174	<b>Check Number</b> 65730
<b>Vendor</b> Nex-Tech (Nex-Tech)	<b>PO Number</b> 23-3489	<b>Invoice #</b> July 2024 Bills	<b>Account Code</b> 06-2300-532-00-00
Nex-Tech (Nex-Tech)	23-3489	July 2024 Bills	06-2300-532-00-01
Nex-Tech (Nex-Tech)	23-3489	July 2024 Bills	06-2400-532-00-00
Nex-Tech (Nex-Tech)	23-3489	July 2024 Bills	06-2400-532-00-01
Nex-Tech (Nex-Tech)	23-3489	July 2024 Bills	06-2400-532-00-02
<b>Sub Total</b>			
<b>Voucher Number</b> July 2024 Bills	<b>Bank Name</b> First National Bank & Trust	<b>Account Number</b> 003174	<b>Check Number</b> 65731
<b>Vendor</b> Northwestern Office Supplies	<b>PO Number</b> 23-3479	<b>Invoice #</b> July 2024 Bills	<b>Account Code</b> 06-1000-610-01-11
Northwestern Office Supplies	23-3479	July 2024 Bills	06-1000-610-02-09
Northwestern Office Supplies	23-3479	July 2024 Bills	06-1000-610-03-09
<b>Sub Total</b>			
<b>Voucher Number</b> July 2024 Bills	<b>Bank Name</b> First National Bank & Trust	<b>Account Number</b> 003174	<b>Check Number</b> 65732
<b>Vendor</b> Norton County Solid Waste	<b>PO Number</b> 23-3478	<b>Invoice #</b> July 2024 Bills	<b>Account Code</b> 08-2600-421-03-00
<b>Sub Total</b>			

<b>Voucher Number</b>	<b>Bank Name</b>	<b>Account Number</b>	<b>Check Number</b>
July 2024 Bills	First National Bank & Trust	003174	65733
<b>Vendor</b>	<b>PO Number</b>	<b>Invoice #</b>	<b>Account Code</b>
Open Spaces Sports	23-3488	July 2024 Bills	06-2300-500-00-00
<b>Sub Total</b>			
<b>Voucher Number</b>	<b>Bank Name</b>	<b>Account Number</b>	<b>Check Number</b>
July 2024 Bills	First National Bank & Trust	003174	65734
<b>Vendor</b>	<b>PO Number</b>	<b>Invoice #</b>	<b>Account Code</b>
Pur-O-Zone	23-3485	July 2024 Bills	16-2600-700-00-00
<b>Sub Total</b>			
<b>Voucher Number</b>	<b>Bank Name</b>	<b>Account Number</b>	<b>Check Number</b>
July 2024 Bills	First National Bank & Trust	003174	65735
<b>Vendor</b>	<b>PO Number</b>	<b>Invoice #</b>	<b>Account Code</b>
Savannah Area	23-3494	July 2024 Bills	35-1000-610-01-04
<b>Sub Total</b>			
<b>Voucher Number</b>	<b>Bank Name</b>	<b>Account Number</b>	<b>Check Number</b>
July 2024 Bills	First National Bank & Trust	003174	65736
<b>Vendor</b>	<b>PO Number</b>	<b>Invoice #</b>	<b>Account Code</b>
Sawyer's Ace Hardware	23-3480	July 2024 Bills	08-2600-430-00-01
<b>Sub Total</b>			
<b>Voucher Number</b>	<b>Bank Name</b>	<b>Account Number</b>	<b>Check Number</b>
July 2024 Bills	First National Bank & Trust	003174	65737
<b>Vendor</b>	<b>PO Number</b>	<b>Invoice #</b>	<b>Account Code</b>
School Specialty	23-3484	July 2024 Bills	06-1000-610-02-09
<b>Sub Total</b>			
<b>Voucher Number</b>	<b>Bank Name</b>	<b>Account Number</b>	<b>Check Number</b>
July 2024 Bills	First National Bank & Trust	003174	65738
<b>Vendor</b>	<b>PO Number</b>	<b>Invoice #</b>	<b>Account Code</b>
Shaylee Vsetecka	23-3498	July 2024 Bills	35-1000-610-01-10
<b>Sub Total</b>			
<b>Voucher Number</b>	<b>Bank Name</b>	<b>Account Number</b>	<b>Check Number</b>
July 2024 Bills	First National Bank & Trust	003174	65739
<b>Vendor</b>	<b>PO Number</b>	<b>Invoice #</b>	<b>Account Code</b>
VISA (VISA1)	23-3490	July 2024 Bills	06-1000-610-02-04
VISA (VISA1)	23-3490	July 2024 Bills	06-1000-610-02-05
VISA (VISA1)	23-3490	July 2024 Bills	06-1000-890-01-01
VISA (VISA1)	23-3490	July 2024 Bills	06-1000-890-01-09

VISA (VISA1)	23-3490	July 2024 Bills	06-2300-890-00-00
VISA (VISA1)	23-3490	July 2024 Bills	06-2400-890-00-00
VISA (VISA1)	23-3490	July 2024 Bills	06-2720-626-00-06
VISA (VISA1)	23-3490	July 2024 Bills	06-2720-626-00-14
VISA (VISA1)	23-3490	July 2024 Bills	06-2720-626-00-15
VISA (VISA1)	23-3490	July 2024 Bills	08-2600-610-00-01
VISA (VISA1)	23-3490	July 2024 Bills	08-2600-700-00-00
VISA (VISA1)	23-3490	July 2024 Bills	08-3400-890-01-01
VISA (VISA1)	23-3490	July 2024 Bills	24-3100-700-01-00
VISA (VISA1)	23-3490	July 2024 Bills	26-2200-502-00-00
<b>Sub Total</b>			
<b>Voucher Number</b>	<b>Bank Name</b>	<b>Account Number</b>	<b>Check Number</b>
July Bills Amy McKinney	First National Bank & Trust	003174	65741
<b>Vendor</b>	<b>PO Number</b>	<b>Invoice #</b>	<b>Account Code</b>
Amy McKinney	23-3503	July Bills Amy McKinney	06-2300-890-00-04
Amy McKinney	23-3503	July Bills Amy McKinney	08-3400-890-01-01
<b>Sub Total</b>			
<b>Grand Total</b>			

On: 7/8/2024 5:51:54 PM

Payee	Amount	Type
Advocate Of Phillips Co., The	\$60.75	Accounts Payable
Description	Issue Date	Amount
Bill	07/08/2024	\$60.75
		<b>\$60.75</b>
Payee	Amount	Type
Andrew Sheley	\$599.00	Accounts Payable
Description	Issue Date	Amount
274674	07/08/2024	\$599.00
		<b>\$599.00</b>
Payee	Amount	Type
Austyn Cox	\$1,250.00	Accounts Payable
Description	Issue Date	Amount
Maxine Sebelius Scholarship	07/08/2024	\$750.00
Stevens Family Trust Scholarship	07/08/2024	\$500.00
		<b>\$1,250.00</b>
Payee	Amount	Type
Braxton Cox	\$700.00	Accounts Payable
Description	Issue Date	Amount
Paul Brassfield Scholarship	07/08/2024	\$700.00
		<b>\$700.00</b>
Payee	Amount	Type
Chris Cochran	\$10.00	Accounts Payable
Description	Issue Date	Amount
Reimbursement	07/08/2024	\$10.00
		<b>\$10.00</b>
Payee	Amount	Type
City Of Almena	\$819.66	Accounts Payable
Description	Issue Date	Amount
July City Bill	07/08/2024	\$80.51
July City Bill	07/08/2024	\$177.20
July City Bill	07/08/2024	\$70.16

July City Bill	07/08/2024	\$140.62
July City Bill	07/08/2024	\$200.00
July City Bill	07/08/2024	\$151.17
		<b>\$819.66</b>

Payee	Amount	Type
ComplianceOne	\$42.00	Accounts Payable
Description	Issue Date	Amount
Number: 318091	07/08/2024	\$42.00
		<b>\$42.00</b>

Payee	Amount	Type
Daynah Bailey	\$700.00	Accounts Payable
Description	Issue Date	Amount
Paul Brassfield Scholarship	07/08/2024	\$700.00
		<b>\$700.00</b>

Payee	Amount	Type
Farmhouse Kitchen & Katering LLC	\$330.00	Accounts Payable
Description	Issue Date	Amount
Invoice #: 000058	07/08/2024	\$330.00
		<b>\$330.00</b>

Payee	Amount	Type
Gabriel Rudd	\$700.00	Accounts Payable
Description	Issue Date	Amount
Paul Brassfield Scholarship	07/08/2024	\$700.00
		<b>\$700.00</b>

Payee	Amount	Type
HTMC	\$294.00	Accounts Payable
Description	Issue Date	Amount
Bill	07/08/2024	\$294.00
		<b>\$294.00</b>

Payee	Amount	Type
Iron Insurance Partners	\$15,785.00	Accounts Payable
Description	Issue Date	Amount
Invoice #: 399677	07/08/2024	\$15,785.00
		<b>\$15,785.00</b>

Payee	Amount	Type
Jeremiah Hansen	\$700.00	Accounts Payable
Description	Issue Date	Amount

Paul Brassfield Scholarship	07/08/2024	\$700.00
		<b>\$700.00</b>
<b>Payee</b>	<b>Amount</b>	<b>Type</b>
Kenton Thalheim	\$700.00	Accounts Payable
<b>Description</b>	<b>Issue Date</b>	<b>Amount</b>
Paul Brassfield Scholarship	07/08/2024	\$700.00
		<b>\$700.00</b>
<b>Payee</b>	<b>Amount</b>	<b>Type</b>
Kowpoke Supply	\$521.86	Accounts Payable
<b>Description</b>	<b>Issue Date</b>	<b>Amount</b>
Monthly Bill	07/08/2024	\$521.86
		<b>\$521.86</b>
<b>Payee</b>	<b>Amount</b>	<b>Type</b>
Mary Baird	\$700.00	Accounts Payable
<b>Description</b>	<b>Issue Date</b>	<b>Amount</b>
Paul Brassfield Scholarship	07/08/2024	\$700.00
		<b>\$700.00</b>
<b>Payee</b>	<b>Amount</b>	<b>Type</b>
Nex-Tech (Nex-Tech)	\$1,250.68	Accounts Payable
<b>Description</b>	<b>Issue Date</b>	<b>Amount</b>
July Bill	07/08/2024	\$476.03
July Bill	07/08/2024	\$60.79
July Bill	07/08/2024	\$164.27
July Bill	07/08/2024	\$73.57
July Bill	07/08/2024	\$476.02
		<b>\$1,250.68</b>
<b>Payee</b>	<b>Amount</b>	<b>Type</b>
Northwestern Office Supplies	\$337.26	Accounts Payable
<b>Description</b>	<b>Issue Date</b>	<b>Amount</b>
Invoice #: 159009	07/08/2024	\$165.37
Invoice #: 159009	07/08/2024	\$132.25
Invoice #: 159009	07/08/2024	\$39.64
		<b>\$337.26</b>
<b>Payee</b>	<b>Amount</b>	<b>Type</b>
Norton County Solid Waste	\$16.80	Accounts Payable
<b>Description</b>	<b>Issue Date</b>	<b>Amount</b>
Invoice #: 67494	07/08/2024	\$16.80
		<b>\$16.80</b>

<b>Payee</b>	<b>Amount</b>	<b>Type</b>
Open Spaces Sports	\$5,000.00	Accounts Payable
<b>Description</b>	<b>Issue Date</b>	<b>Amount</b>
Invoice #: 4894	07/08/2024	\$5,000.00
		<b>\$5,000.00</b>
<b>Payee</b>	<b>Amount</b>	<b>Type</b>
Pur-O-Zone	\$9,763.80	Accounts Payable
<b>Description</b>	<b>Issue Date</b>	<b>Amount</b>
Quote #: 53518	07/08/2024	\$9,763.80
		<b>\$9,763.80</b>
<b>Payee</b>	<b>Amount</b>	<b>Type</b>
Savannah Area	\$700.00	Accounts Payable
<b>Description</b>	<b>Issue Date</b>	<b>Amount</b>
Paul Brassfield Scholarship	07/08/2024	\$700.00
		<b>\$700.00</b>
<b>Payee</b>	<b>Amount</b>	<b>Type</b>
Sawyer's Ace Hardware	\$541.25	Accounts Payable
<b>Description</b>	<b>Issue Date</b>	<b>Amount</b>
Invoice: 150281	07/08/2024	\$541.25
		<b>\$541.25</b>
<b>Payee</b>	<b>Amount</b>	<b>Type</b>
School Specialty	\$83.15	Accounts Payable
<b>Description</b>	<b>Issue Date</b>	<b>Amount</b>
Invoice #: 208134120407	07/08/2024	\$83.15
		<b>\$83.15</b>
<b>Payee</b>	<b>Amount</b>	<b>Type</b>
Shaylee Vsetecka	\$750.00	Accounts Payable
<b>Description</b>	<b>Issue Date</b>	<b>Amount</b>
Maxine Sebelius Scholarship	07/08/2024	\$750.00
		<b>\$750.00</b>
<b>Payee</b>	<b>Amount</b>	<b>Type</b>
VISA (VISA1)	\$8,076.40	Accounts Payable
<b>Description</b>	<b>Issue Date</b>	<b>Amount</b>
June Visa Bill	07/08/2024	\$119.96
June Visa Bill	07/08/2024	\$96.98
June Visa Bill	07/08/2024	\$2,798.96
June Visa Bill	07/08/2024	\$404.78

June Visa Bill	07/08/2024	\$740.94
June Visa Bill	07/08/2024	\$607.95
June Visa Bill	07/08/2024	\$194.73
June Visa Bill	07/08/2024	\$56.34
June Visa Bill	07/08/2024	\$187.37
June Visa Bill	07/08/2024	\$211.09
June Visa Bill	07/08/2024	\$1,322.12
June Visa Bill	07/08/2024	\$847.93
June Visa Bill	07/08/2024	\$59.25
June Visa Bill	07/08/2024	\$428.00
		<b>\$8,076.40</b>

<b>Payee</b>	<b>Amount</b>	<b>Type</b>
Amy McKinney	\$237.44	Accounts Payable
<b>Description</b>	<b>Issue Date</b>	<b>Amount</b>
Reimbursement	07/08/2024	\$71.86
Reimbursement	07/08/2024	\$165.58
		<b>\$237.44</b>
		<b>\$50,669.05</b>

# USD 212

## Check Listing Report

Accounting Cycle: FY 24-25; Begin Date: 07/01/2024; End Date: 07/08/2024; Bank: First National Bank & Trust; Sort By Element: FUND; Account Expression: [All]; Created On: 7/8/2024 5:51:55 PM

Check Date	Check Number	Payee	Type	Amount
07/08/2024	65714	Advocate Of Phillips Co., The	Accounts Payable	\$60.75
07/08/2024	65715	Andrew Sheley	Accounts Payable	\$599.00
07/08/2024	65716	Austyn Cox	Accounts Payable	\$1,250.00
07/08/2024	65717	Braxton Cox	Accounts Payable	\$700.00
07/08/2024	65718	Chris Cochran	Accounts Payable	\$10.00
07/08/2024	65719	City Of Almena	Accounts Payable	\$819.66
07/08/2024	65720	ComplianceOne	Accounts Payable	\$42.00
07/08/2024	65721	Daynah Bailey	Accounts Payable	\$700.00
07/08/2024	65722	Farmhouse Kitchen & Katering LLC	Accounts Payable	\$330.00
07/08/2024	65723	Gabriel Rudd	Accounts Payable	\$700.00
07/08/2024	65724	HTMC	Accounts Payable	\$294.00
07/08/2024	65725	Iron Insurance Partners	Accounts Payable	\$15,785.00
07/08/2024	65726	Jeremiah Hansen	Accounts Payable	\$700.00
07/08/2024	65727	Kenton Thalheim	Accounts Payable	\$700.00
07/08/2024	65728	Kowpoke Supply	Accounts Payable	\$521.86
07/08/2024	65729	Mary Baird	Accounts Payable	\$700.00
07/08/2024	65730	Nex-Tech (Nex-Tech)	Accounts Payable	\$1,250.68
07/08/2024	65731	Northwestern Office Supplies	Accounts Payable	\$337.26
07/08/2024	65732	Norton County Solid Waste	Accounts Payable	\$16.80
07/08/2024	65733	Open Spaces Sports	Accounts Payable	\$5,000.00
07/08/2024	65734	Pur-O-Zone	Accounts Payable	\$9,763.80
07/08/2024	65735	Savannah Area	Accounts Payable	\$700.00
07/08/2024	65736	Sawyer's Ace Hardware	Accounts Payable	\$541.25
07/08/2024	65737	School Specialty	Accounts Payable	\$83.15
07/08/2024	65738	Shaylee Vsetecka	Accounts Payable	\$750.00
07/08/2024	65739	VISA (VISA1)	Accounts Payable	\$8,076.40
07/08/2024	65741	Amy McKinney	Accounts Payable	\$237.44
<b>Sub Total</b>				<b>\$50,669.05</b>

# USD 212

## Check Listing Report

Accounting Cycle: FY 24-25; Begin Date: 07/01/2024; End Date: 07/08/2024; Bank: First National Bank & Trust; Sort By Element: FUND; Account Expression: [All]; Created On: 7/8/20

Check Date	Check Number	Payee	Description	Type
07/08/2024	65714	Advocate Of Phillips Co., The	Inv: July 2024 Bills	Accounts Payable
07/08/2024	65741	Amy McKinney	Reimbursements	Accounts Payable
07/08/2024	65715	Andrew Sheley	Inv: July 2024 Bills	Accounts Payable
07/08/2024	65716	Austyn Cox	Maxine Sebelius and Stevens Family Scholarships	Accounts Payable
07/08/2024	65717	Braxton Cox	Paul Brassfield Scholarship	Accounts Payable
07/08/2024	65718	Chris Cochran	Reimbursment	Accounts Payable
07/08/2024	65719	City Of Almena	July City Bill	Accounts Payable
07/08/2024	65720	ComplianceOne	Number: 318091	Accounts Payable
07/08/2024	65721	Daynah Bailey	Paul Brassfield Scholarship	Accounts Payable
07/08/2024	65722	Farmhouse Kitchen & Katering LLC	Invoice #: 000058	Accounts Payable
07/08/2024	65723	Gabriel Rudd	Paul Brassfield Scholarship	Accounts Payable
07/08/2024	65724	HTMC	Inv: July 2024 Bills	Accounts Payable
07/08/2024	65725	Iron Insurance Partners	Invoice#: 399677	Accounts Payable
07/08/2024	65726	Jeremiah Hansen	Paul Brassfield Scholarship	Accounts Payable
07/08/2024	65727	Kenton Thalheim	Paul Brassfield Scholarship	Accounts Payable
07/08/2024	65728	Kowpoke Supply	Monthly Bill	Accounts Payable
07/08/2024	65729	Mary Baird	Paul Brassfield Scholarship	Accounts Payable
07/08/2024	65730	Nex-Tech (Nex-Tech)	July Bill Account's : 15740 and 309012	Accounts Payable
07/08/2024	65731	Northwestern Office Supplies	Invoice# 159009	Accounts Payable
07/08/2024	65732	Norton County Solid Waste	Invoice #: 67494	Accounts Payable
07/08/2024	65733	Open Spaces Sports	Invoice#:4894	Accounts Payable
07/08/2024	65734	Pur-O-Zone	Quote #:53518	Accounts Payable
07/08/2024	65735	Savannah Area	Paul Brassfield Scholarship	Accounts Payable
07/08/2024	65736	Sawyer's Ace Hardware	Invoice: 150281	Accounts Payable
07/08/2024	65737	School Specialty	Invoice #: 208134120407	Accounts Payable
07/08/2024	65738	Shaylee Vsetecka	Maxine Sebelius Scholarship	Accounts Payable
07/08/2024	65739	VISA (VISA1)	June Visa Bill	Accounts Payable
<b>Sub Total</b>				

12/24 5:51:55 PM

Amount
\$60.75
\$237.44
\$599.00
\$1,250.00
\$700.00
\$10.00
\$819.66
\$42.00
\$700.00
\$330.00
\$700.00
\$294.00
\$15,785.00
\$700.00
\$700.00
\$521.86
\$700.00
\$1,250.68
\$337.26
\$16.80
\$5,000.00
\$9,763.80
\$700.00
\$541.25
\$83.15
\$750.00
\$8,076.40
<b>\$50,669.05</b>

# Current Cash Balance

Sorted by Site ID, Group ID, Activity ID.  
From 07/01/2024 to 07/31/2024.

Site ID Group ID	Site Name Group Name	Activity ID	Activity Name	Beginning Cash	Receipts	Disbursements	Adjustments	Cash Balance
<b>NVHS</b>	<b>Northern Valley High School</b>							
<b>A</b>	<b>ATHLETICS</b>							
	1010		HIGH SCHOOL ATHLETICS	10,618.44	0.00	0.00	0.00	10,618.44
	<b>A Totals:</b>			10,618.44	0.00	0.00	0.00	10,618.44
<b>B</b>	<b>CLUBS &amp; ORGANIZATIONS</b>							
	2010		STUDENT COUNCIL	9,479.63	0.00	0.00	0.00	9,479.63
	2020		KAY	3,910.96	0.00	0.00	0.00	3,910.96
	2050		HUSKY MUSIC CLUB	1,924.33	0.00	0.00	0.00	1,924.33
	2060		FFA	13,137.25	0.00	0.00	0.00	13,137.25
	2070		SCHOLARS BOWL	88.77	0.00	0.00	0.00	88.77
	2080		DANCE AND CHEER	4,227.41	0.00	0.00	0.00	4,227.41
	2090		FORENSICS	2,130.36	0.00	0.00	0.00	2,130.36
	3000		TECHNOLOGY CLUB	828.76	0.00	0.00	0.00	828.76
	3010		Food Science	66.10	0.00	0.00	0.00	66.10
	3020		VOLLEYBALL CLUB	2,117.88	0.00	0.00	0.00	2,117.88
	3030		FACS	914.82	0.00	0.00	0.00	914.82
	3050		Interactive Media	-22.66	0.00	0.00	0.00	-22.66
	<b>B Totals:</b>			38,803.61	0.00	0.00	0.00	38,803.61
<b>C</b>	<b>GRADUATING CLASSES</b>							
	3114		CLASS OF 2014	2,838.60	0.00	0.00	0.00	2,838.60
	3115		CLASS OF 2015	1,341.17	0.00	0.00	0.00	1,341.17
	3116		CLASS OF 2016	27.50	0.00	0.00	0.00	27.50
	3119		CLASS OF 2019	2,003.91	0.00	0.00	0.00	2,003.91
	3121		CLASS OF 2021	1,767.59	0.00	0.00	0.00	1,767.59
	3122		CLASS OF 2022	102.65	0.00	0.00	0.00	102.65
	3123		CLASS OF 2023	325.03	0.00	0.00	0.00	325.03
	3124		CLASS OF 2024-Seniors	0.00	0.00	0.00	0.00	0.00
	3125		CLASS OF 2025-Juniors	6,860.18	0.00	0.00	0.00	6,860.18
	3126		CLASS OF 2026-Sophmores	2,954.83	0.00	0.00	0.00	2,954.83
	3127		Class Of 2027- Freshman	1,380.50	0.00	0.00	0.00	1,380.50
	<b>C Totals:</b>			19,601.96	0.00	0.00	0.00	19,601.96
<b>D</b>	<b>DISTRICT MONIES</b>							
	4020		HIGH SCHOOL PETTY CASH	1,125.00	0.00	0.00	0.00	1,125.00
	<b>D Totals:</b>			1,125.00	0.00	0.00	0.00	1,125.00
<b>E</b>	<b>YEARBOOK</b>							
	7000		YEARBOOK	13,597.27	0.00	0.00	0.00	13,597.27
	<b>E Totals:</b>			13,597.27	0.00	0.00	0.00	13,597.27

# Current Cash Balance

Sorted by Site ID, Group ID, Activity ID.  
From 07/01/2024 to 07/31/2024.

Site ID Group ID	Site Name Group Name	Activity ID	Activity Name	Beginning Cash	Receipts	Disbursements	Adjustments	Cash Balance
F	MISC							
	7030		GREENHOUSE	41.47	0.00	0.00	0.00	41.47
	7060		BOX TOPS FOR EDUCATION	256.51	0.00	0.00	0.00	256.51
	8011		Interest Paid To Account	801.80	0.00	0.00	0.00	801.80
			F Totals:	1,099.78	0.00	0.00	0.00	1,099.78
G	SALES TAX							
	8010		SALES TAX	-85.62	0.00	0.00	0.00	-85.62
			G Totals:	-85.62	0.00	0.00	0.00	-85.62
			NVHS Activity Totals:	84,760.44	0.00	0.00	0.00	84,760.44

	Begin Balance	Transfers	Receipts	Disbursements	Adjustments	End Balance
NVHS Checking:			0.00	0.00		
NVHS Investment:						
NVHS Bank Balances:	84,760.44		0.00	0.00	0.00	84,760.44

Report Activity Totals:	84,760.44	0.00	0.00	0.00	84,760.44
-------------------------	-----------	------	------	------	-----------

# USD 212

## Cash Summary Report

Accounting Cycle: FY 24-25; Beginning Period: Period 01 (07/01/2024 - 07/31/2024) ; Ending Period: Period 01 (07/01/2024 - 07/31/2024) ; Show Prior Year Expense/Encumbrance: Transactions after the Last Period: None; Exclude Closing Entries: No; Include Unposted Transactions: No; Created On: 7/8/2024 6:00:35 PM

Fund	Description	Beginning Balance	Revenue	Expenditure	Other	Ending Balance
06	GENERAL FUND	\$169.84	\$0.00	(\$12,357.71)	\$0.00	(\$12,187.87)
07	FEDERAL FUNDS	\$3,699.93	\$0.00	\$0.00	\$0.00	\$3,699.93
08	SUPPLEMENTAL GENERAL FUND	\$25,296.99	\$0.00	(\$20,679.12)	\$0.00	\$4,617.87
11	FOUR YEAR OLD AT RISK FUND	\$8,668.54	\$0.00	\$0.00	\$0.00	\$8,668.54
13	K-12 AT RISK FUND	\$42,865.91	\$0.00	\$0.00	\$0.00	\$42,865.91
14	BILINGUAL EDUCATION	\$325.00	\$0.00	\$0.00	\$0.00	\$325.00
16	CAPITAL OUTLAY	\$430,368.18	\$0.00	(\$9,763.80)	\$0.00	\$420,604.38
18	DRIVER TRAINING	\$2,362.58	\$0.00	\$0.00	\$0.00	\$2,362.58
24	FOOD SERVICE	\$16,135.14	\$0.00	(\$59.25)	\$0.00	\$16,075.89
26	PROFESSIONAL DEVELOPMENT FUND	\$10,151.97	\$0.00	(\$758.00)	\$0.00	\$9,393.97
30	SPECIAL EDUCATION	\$57,456.14	\$0.00	\$0.00	\$0.00	\$57,456.14
34	VOCATIONAL EDUCATION	\$13,678.71	\$0.00	(\$151.17)	\$0.00	\$13,527.54
35	GIFTS/GRANTS	\$49,865.83	\$0.00	(\$6,900.00)	\$0.00	\$42,965.83
51	KPERS RETIREMENT CONTRIBUTIONS	\$0.00	\$0.00	\$0.00	\$0.00	\$0.00
53	CONTINGENCY FUND	\$225,000.00	\$0.00	\$0.00	\$0.00	\$225,000.00
55	TEXTBOOK RENTAL	\$39,406.18	\$0.00	\$0.00	\$0.00	\$39,406.18
81	LIBRARY GRANT	\$911.02	\$0.00	\$0.00	\$0.00	\$911.02
85	KS COORDINATED SCHOOL HEALTH	\$1,958.14	\$0.00	\$0.00	\$0.00	\$1,958.14
<b>Sub Total</b>		<b>\$928,320.10</b>	<b>\$0.00</b>	<b>(\$50,669.05)</b>	<b>\$0.00</b>	<b>\$877,651.05</b>

No; Prior Year Ending Balance for Beginning Balance: Yes; Include

<b>Encumbrances</b>	<b>Liabilities</b>	<b>Available</b>
(\$3,593.43)	\$0.00	(\$15,781.30)
\$0.00	\$0.00	\$3,699.93
\$0.00	\$0.00	\$4,617.87
\$0.00	\$0.00	\$8,668.54
\$0.00	\$0.00	\$42,865.91
\$0.00	\$0.00	\$325.00
\$0.00	\$0.00	\$420,604.38
\$0.00	\$0.00	\$2,362.58
\$0.00	\$0.00	\$16,075.89
\$0.00	\$0.00	\$9,393.97
\$0.00	\$0.00	\$57,456.14
\$0.00	\$0.00	\$13,527.54
\$0.00	\$0.00	\$42,965.83
\$0.00	\$0.00	\$0.00
\$0.00	\$0.00	\$225,000.00
\$0.00	\$0.00	\$39,406.18
\$0.00	\$0.00	\$911.02
\$0.00	\$0.00	\$1,958.14
<b>(\$3,593.43)</b>	<b>\$0.00</b>	<b>\$874,057.62</b>

# USD 212

## Cash Summary Report

Accounting Cycle: FY 24-25; Beginning Period: Period 01 (07/01/2024 - 07/31/2024) ; Ending Period: Period 01 (07/01/2024 - 07/31/2024) ; Show Prior Year Expense/Encumbrance: No; Prior Year Ending Balance for Beginning Balance: Yes; Include Transactions after the Last Period: None; Exclude Closing Entries: No; Include Unposted Transactions: No; Created On: 7/8/2024 6:00:35 PM

Fund	Description	Liabilities (Beginning)	Liabilities (Ending)	Cash Journal Entries	Other Total
06	GENERAL FUND	\$0.00	\$0.00	\$0.00	\$0.00
08	SUPPLEMENTAL GENERAL FUND	\$0.00	\$0.00	\$0.00	\$0.00
16	CAPITAL OUTLAY	\$0.00	\$0.00	\$0.00	\$0.00
24	FOOD SERVICE	\$0.00	\$0.00	\$0.00	\$0.00
26	PROFESSIONAL DEVELOPMENT FUND	\$0.00	\$0.00	\$0.00	\$0.00
34	VOCATIONAL EDUCATION	\$0.00	\$0.00	\$0.00	\$0.00
35	GIFTS/GRANTS	\$0.00	\$0.00	\$0.00	\$0.00
<b>Sub Total</b>		<b>\$0.00</b>	<b>\$0.00</b>	<b>\$0.00</b>	<b>\$0.00</b>

# Northern Valley Schools - Long Island

Activity Fund Report (Summary of Cash Receipts & Disbursements)  
Fiscal Year Statement 2024

Account	Starting Balance	Cash Receipts	Disburse-ments	Current Balance	Out-Standing checks	Bank Balance
Petty Cash	\$212.27	\$1,137.73	\$491.65	\$858.35	\$0.00	\$858.35
Service Club	\$1,941.82	\$14,576.17	\$14,436.45	\$2,081.54	\$159.91	\$2,241.45
Athletics	\$923.05	\$4,161.00	\$4,101.10	\$982.95	\$64.40	\$1,047.35
<b>Totals</b>	\$ 3,077.14	\$ 19,874.90	\$ 19,029.20	\$ 3,922.84	\$ 224.31	\$ 4,147.15

Previous Bank Balance	\$	3,077.14
Plus Deposits	\$	19,874.90
Less checks paid	\$	18,804.89
<b>Current Statement Balance</b>		<b>\$4,147.15</b>
Outstanding Checks	\$	224.31
Plus Deposits Not Made	\$	-
<b>Book Balance as of End of Month</b>		<b>\$3,922.84</b>

Outstanding check(s) #

check/Debit	\$	159.91
Debit	\$	64.40

Outstanding check(s) #

<b>Total</b>	\$ 224.31

Principal Signature:

**Completed by: Sommer Yocum (Middle School Secretary)**

Month	Petty Cash		Service Club		Athletics	
	Paid Out	Received	Paid Out	Received	Paid Out	Received
Start out with		\$ 212.27		\$ 1,941.82		\$ 923.05
July	\$ -	\$ 537.73	\$ -	\$ -	\$ -	\$ -
August	\$ 231.87	\$ -	\$ 493.12	\$ -	\$ 10.00	\$ -
September	\$ 4.43	\$ -	\$ 2,624.41	\$ 1,374.13	\$ 1,430.00	\$ 308.00
October	\$ -	\$ -	\$ 2,250.33	\$ 2,048.41	\$ 350.16	\$ 672.00
November	\$ -	\$ -	\$ 1,084.09	\$ 4,271.65	\$ 645.00	\$ 318.00
December	\$ -	\$ -	\$ 2,898.49	\$ 2,684.60	\$ 280.00	\$ 834.00
January	\$ 68.00	\$ -	\$ 934.14	\$ 345.95	\$ 145.41	\$ -
February	\$ -	\$ -	\$ 384.96	\$ 1,411.42	\$ 465.00	\$ 659.00
March	\$ -	\$ -	\$ 289.14	\$ -	\$ -	\$ -
April	\$ 3.31	\$ -	\$ 1,552.68	\$ 1,316.45	\$ 711.13	\$ 1,370.00
May	\$ 184.04	\$ -	\$ 1,925.09	\$ 717.39	\$ 64.40	\$ -
June	\$ -	\$ 600.00	\$ -	\$ 406.17	\$ -	\$ -
<b>Totals</b>	\$ 491.65	\$ 1,137.73	\$ 14,436.45	\$ 14,576.17	\$ 4,101.10	\$ 4,161.00

End of year totals

**FISCAL YEAR 2024**







2137 Roosevelt Avenue  
Racine, WI 53406  
info@windowwellsupply.com  
**Customer Service: (262) 633-3707**

## Window Well Atrium Installation Instructions

**NOTE:** TO PREVENT DAMAGE DURING INSTALLATION, DO NOT REMOVE PROTECTIVE FILM FROM COVER UNTIL INSTALLATION IS COMPLETE. RETURNS CANNOT BE ACCEPTED ONCE PROTECTIVE FILM HAS BEEN REMOVED.

### Included in kit:



Atrium left panel



Phillips Screwdriver Atrium right panel

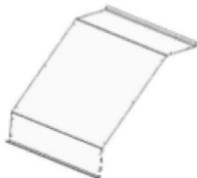

### What you will need:



Marker Atrium front panel



#8/32-0.75 Phillips pan

### For installation to concrete or brick

### wall, you will also need:

head screw, flat washer and nylon-insert nut

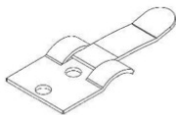

Quick release clips

3/16" Masonry drill bit



Hammer



Masonry Anchors

**Installation:**

**STEP 1:**

Assemble the left and right panels to the front panel using the screws, washers and nylon-insert nuts provided. Ensure that the vertical flanges on each side panel are facing outward.

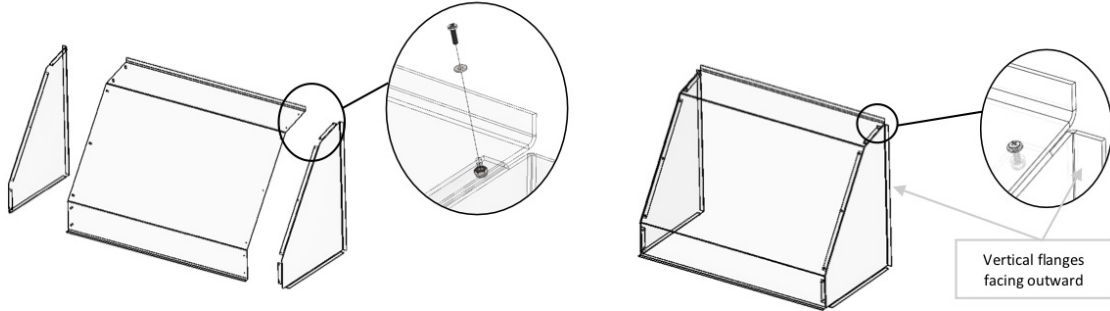

**STEP 2:**

Center atrium on well. Flip quick connect clip to open position and align with atrium side flange, near the center of the flange. Mark both clip hole locations and use screws provided to attach clip to wall. Repeat clip installation on opposite side.

*If assembling clip to concrete or brick, use a 3/16" masonry bit to drill each clip hole to a 1 1/2" depth. Use a hammer to insert masonry anchors provided and then screw the clips to the anchors in the concrete/brick.*

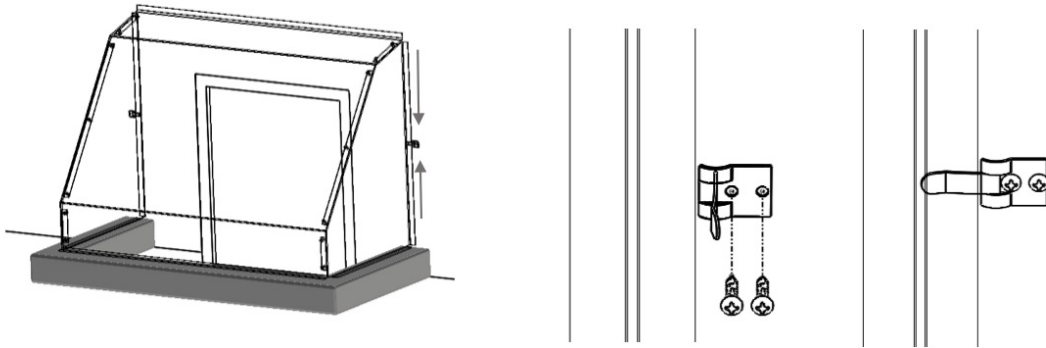

**STEP 3:**

Flip both quick connect clips to closed position.

*Your window well atrium  
installation is now complete!*

For questions, please call Window Well Supply Customer Service, Monday through Friday, 8:00AM - 5:00PM CST at (262) 633-3707.

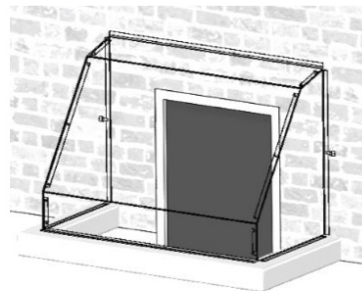



**Installation:**

**STEP 1:**

Assemble the left and right panels to the front panel using the screws, washers and nylon-insert nuts provided. Ensure that the vertical flanges on each side panel are facing outward.

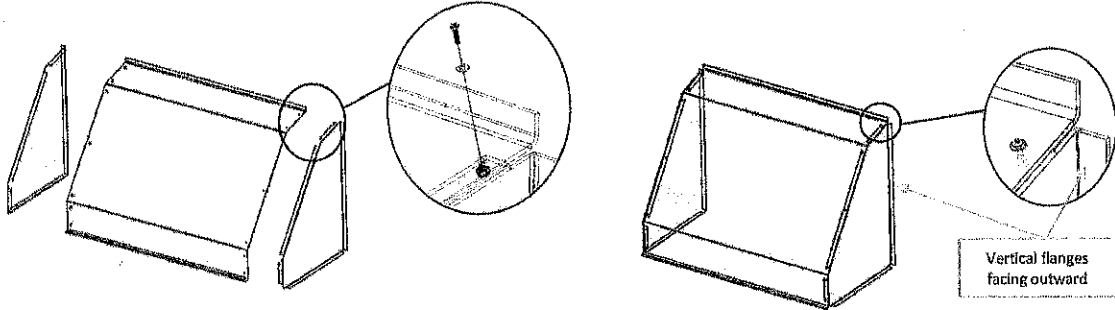

**STEP 2:**

Center atrium on well. Flip quick connect clip to open position and align with atrium side flange, near the center of the flange. Mark both clip hole locations and use screws provided to attach clip to wall. Repeat clip installation on opposite side.

*If assembling clip to concrete or brick, use a 3/16" masonry bit to drill each clip hole to a 1 1/2" depth. Use a hammer to insert masonry anchors provided and then screw the clips to the anchors in the concrete/brick.*

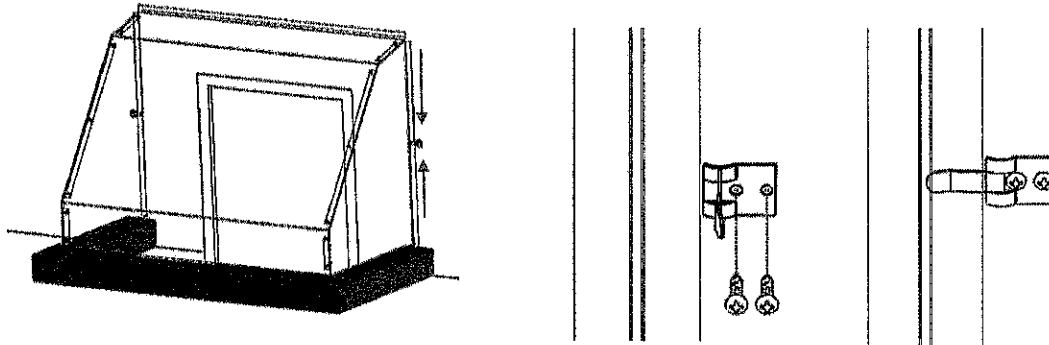

**STEP 3:**

Flip both quick connect clips to closed position.

*Your window well atrium  
installation is now complete!*

For questions, please call Window Well Supply Customer Service, Monday through Friday, 8:00AM - 5:00PM CST at (262) 633-3707.

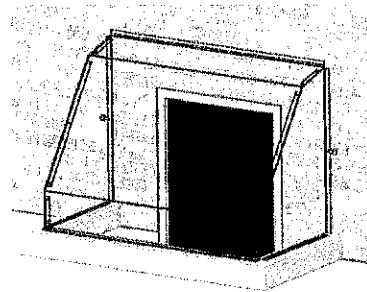

REV A.1

What are you looking for?



Ask an Expert

Account

Ask an Expert

Live (262) 633-3707

Live Chat

info@windowwellsupply.com

What are you looking for?

Home / Your Cart

## Your Cart (6 items)



Window Well Supply

Custom Atrium

Window Well Cover - D

Cover Width: 107

Cover Projection: 36

Cover Height: 24

Subtotal: \$7,008.50

Shipping: Free

Total: **\$7,008.50**

[Proceed to Checkout](#)

[Change](#)



**WINDOWWELL**  
SUPPLY™



-- OR USE --

**ruyrui**



Price      Quantity

\$1,194.8

Total

\$4,779.24

Window Well Supply

**Custom Atrium**

**Window Well Cover - D**



Cover Width: 77

Cover Projection: 36

Cover Height: 24

Change

Price      Quantity

\$1,114.6

Total

\$2,229.26

Pay with **amazon**



Pay over time for orders over \$50 with **affirm**



Window Well Supply is your premier provider for all your basement access needs. Offering everything from Window Wells, to Basement Windows, to Custom Window Well covers, we are a professional supply company with unbeatable customer service. Contact us today and let us assist you through every step of your project!

## COMPANY

- About Us
- Photo Gallery
- Blog

## SUPPORT

- Technical Information
- Lifetime Warranty
- Shipping

## CONTACT

- Contact Us
- Chat with an Expert
- Call Us: (262) 633-3707

## NEWSLETTER

Sign up for our newsletter and receive updates on new products, how-to's & company information.

Enter your email

Subscribe



NORTHERN VALLEY USD#212

512 W. Bryant PO Box 217

Almena, KS 67622

Email: [ktharman@nvhuskies.org](mailto:ktharman@nvhuskies.org)

Personal Information

APPLICATION FOR EMPLOYMENT

Name (Last Name First) <b>Patterson Clayson</b>		Social Security Number	
Present Address <b>4021 S Concord Street</b>		City <b>Rogers</b>	State <b>AR</b>
Present Address		City	Zip <b>72758</b>
Present Address		State	Zip
Are 18 Years Old Or Older? <input checked="" type="checkbox"/> YES <input type="checkbox"/> NO	Phone <b>870-754-1589</b>		

Desired Employment

Position <b>Janitor</b>		Date You Can Start <b>August</b>
Are You Employed Now? <input type="checkbox"/> YES <input checked="" type="checkbox"/> NO	If So May We Contact You Current Employer? <input type="checkbox"/> Yes <input type="checkbox"/> NO	
Have You Ever Worked For Northern Valley USD212 Before? <input type="checkbox"/> Yes <input checked="" type="checkbox"/> NO	When?	What Position Did You Hold?
Reason For Leaving		
Name Of Last Supervisor At Northern Valley USD212		

High School

Name And Location of School <b>Chilhowee Highschool</b>	Diploma <input checked="" type="checkbox"/> Yes <input type="checkbox"/> No	If Not, GED <input type="checkbox"/> Yes <input type="checkbox"/> No
--	--	---

Post Secondary Education

Name and Location of School	Credits Earned	Degree	Major

General

Special Training or Skills Relevant to This Position <b>Not afraid to clean, have two little ones that love making messes</b>
--

1. Have you ever been convicted of, or currently charged with, a crime other than a minor traffic violation?  
 Yes  No
2. Have you ever been charged with a crime involving dishonesty?  Yes  No
3. Have you ever been charged with a crime involving a controlled substance?  Yes  No
4. Have you ever been involved with a crime involving a child?  Yes  No
5. Have you ever entered into a diversion agreement after being charged with any crime described in questions 1 - 4 above?  Yes  No
6. Are criminal charges pending against you in any state involving any of the offenses described in questions 1 - 4 above?  Yes  No

### Employment History

LIST BELOW START WITH THE MOST RECENT EMPLOYER

Name of Previous Employer <b>Nwa Reno</b>				
Address		City <b>Houston</b>	State <b>Texas</b>	Zip
Start Date <b>March 1st 2024</b>	End Date	Job Title <b>Head Renovator</b>		
Starting Salary (Please Indicate Yearly / Weekly / Hourly) <b>1000\$ weekly</b>	Ending Salary (Please Indicate Yearly / Weekly / Hourly) <b>1000\$ weekly</b>	May We Contact Your Supervisor? <input type="checkbox"/> Yes <input checked="" type="checkbox"/> No		
Name Of Supervisor		Title	Phone	
Duties  <b>Doing any part of a remodel that needed to be done</b>				
Reason For Leaving <b>Company closed</b>				

Name of Previous Employer <b>Best Blades</b>				
Address		City <b>Pea ridge</b>	State <b>AR</b>	Zip
Start Date <b>August 2020</b>	End Date <b>March 2023</b>	Job Title <b>Crew lead</b>		
Starting Salary (Please Indicate Yearly / Weekly / Hourly) <b>12hr</b>	Ending Salary (Please Indicate Yearly / Weekly / Hourly) <b>800 weekly</b>	May We Contact Your Supervisor? <input checked="" type="checkbox"/> Yes <input type="checkbox"/> No		
Name Of Supervisor <b>Trevor Barton</b>		Title <b>Owner</b>	Phone	
Duties  <b>Head of mowing, fixing equipment</b>				
Reason For Leaving <b>Got a different job, that paid more</b>				

Name of Previous Employer <b>Pointe Royale</b>				
Address		City <b>Branson</b>	State <b>Mo</b>	Zip

Start Date <b>February 2020</b>	End Date <b>August 2020</b>	Job Title <b>Groundskeeper</b>
Starting Salary (Please Indicate Yearly / Weekly / Hourly) <b>12hr</b>	Ending Salary (Please Indicate Yearly / Weekly / Hourly) <b>12hr</b>	May We Contact Your Supervisor? <input type="checkbox"/> Yes <input type="checkbox"/> No
Name Of Supervisor <b>Shane</b>	Title	Phone
Duties		
Reason For Leaving <b>Moved in with wife to a different town</b>		

Name of Previous Employer <b>Wendy's</b>				
Address		City <b>Harrison</b>	State <b>Ar</b>	Zip
Start Date	End Date	Job Title <b>Manager</b>		
Starting Salary (Please Indicate Yearly / Weekly / Hourly) <b>10hr</b>	Ending Salary (Please Indicate Yearly / Weekly / Hourly) <b>11.50hr</b>	May We Contact Your Supervisor? <input type="checkbox"/> Yes <input type="checkbox"/> No		
Name Of Supervisor <b>Justy williams</b>		Title <b>General manager</b>	Phone	
Duties  <b>Making sure restaurant was clean during my shift, make shift schedule, make sure we had product</b>				
Reason For Leaving <b>Wanted to get a different job</b>				

**References**  
PLEASE PROVIDE NAMES OF THREE INDIVIDUALS WHO ARE NOT RELATED TO YOU AND YOU HAVE KNOWN AT LEAST THREE YEARS

Name <b>Dean Lewis</b>	Address	Title	Phone <b>(573) 355-3568</b>
Name <b>Tyler Wilson</b>	<i>No Post</i> Address	Title	Phone <b>+18705172811</b>
Name <b>Trevor Barton</b>	Address	Title	Phone <b>+1 (479) 531-6620</b>

### AUTHORIZATION

"I CERTIFY THAT THE FACTS CONTAINED IN THIS APPLICATION ARE TRUE AND COMPLETE TO THE BEST OF MY KNOWLEDGE AND UNDERSTAND THAT, IF EMPLOYED, FALSIFIED STATEMENTS ON THIS APPLICATION SHALL BE GROUNDS FOR DISMISSAL, I AUTHORIZE INVESTIGATION OF ALL STATEMENTS CONTAINED HEREIN AND THE REFERENCES AND EMPLOYERS LISTED ABOVE TO GIVE YOU ANY AND ALL INFORMATION CONCERNING MY PREVIOUS EMPLOYMENT AND ANY PERTINENT INFORMATION THEY MAY HAVE, PERSONAL OR OTHERWISE AND RELEASE THE COMPANY FROM ALL LIABILITY FOR ANY DAMAGE THAT MAY RESULT FROM UTILIZATION OF SUCH INFORMATION, I ALSO UNDERSTAND AND AGREE THAT NO REPRESENTATIVE OF THE COMPANY HAS ANY AUTHORITY TO ENTER INTO ANY AGREEMENT FOR EMPLOYMENT FOR ANY SPECIFIED PERIOD OF TIME, OR TO MAKE ANY AGREEMENT COIHRARY TO THE FOREGOING, UNLESS IT IS IN WRITING AND SIGNED BY AN AUTHORIZED COMPANY REPRESENTATIVE,"

Signature	Date
-----------	------

You will be required to sign them application when you are interviewed for this position.

To whom it may concern,

I (Kacie Yocum) am requesting Friday July 5<sup>th</sup>, 2024 off with PTO leave as the day care where my daughter attends will be closed both Thursday July 4<sup>th</sup> and Friday July 5<sup>th</sup>. Thank you for your time.

Kacie Yocum

CONSENT CALENDAR JULY 8<sup>th</sup>, 2024

1. Adopt the resolution to hold Board Meetings for the 2024 - 25 term as stated, the second Monday each month.
2. Appoint the following District Officers –
  - a. Clerk, Amber Brown
  - b. Deputy Clerk, Kenzi Sheley
  - c. Treasurer, Kacie Yocum
  - d. Attorney, Use KASB
  - e. Truancy Officers, Marvin Gebhard, Pre K-8  
Ken Tharman, 9-12
  - f. KPERS Designated Agent, Amber Brown
  - g. ADA Compliance Coordinator, Ken Tharman
  - h. Freedom of Information Officer, Ken Tharman
  - i. Point of Contact for Background Checks, Ken Tharman
  - j. Reporting Truant Children, (K.S.A.72-3121) Ken Tharman (HS) / Marvin Gebhard (Pre K-8 Principal)
  - k. Homeless Children Liaison, Ken Tharman
  - l. Foster Care Liaison, Ken Tharman
  - m. Title IX Coordinator, Ken Tharman
3. Designate Depositories for District Funds – All banks of Norton and Phillips Counties with Equity Bank and the First National Bank of Long Island as principal depositories. Bank Signature Holders – Hilary Van Patten, Amber Brown, Kacie Yocum, & Ken Tharman (K.S.A.9 – 1401)
4. Official Newspaper for the district shall be the Phillips County Review. (K.S.A. 64-101)
5. Request the right to waive GAAP-prescribed financial statements and General Fixed assets accounting for the 2024- 25 terms. (K.S.A. 75-1120a)
6. Appoint the following officials for School Food Service Program & all Federal Programs for 2024 - 25.  
  
Authorized Representative – Becky Delimont  
Free & Reduced Meal Applications –
  1. Determining Official – Kenzi Sheley
  2. Hearing Official – Ken Tharman
7. Authorize participation in the School Food Service Program for school lunches, breakfast, Cash or Commodities and Bonus Commodities.
8. Adopt the 1,116-hour school term for the 2024 - 25 school year.

## Page 2 – Consent Calendar July 8<sup>th</sup>, 2024

9. Approve passes for Senior Citizens (age 65 to qualify) who are residents of USD 212.
10. Set district mileage rate at 67 cents per mile for reimbursement to employees for use of personal vehicles for authorized district business. (K.S.A. 75-3203)
11. Approve application for Title I, Title II, Title IV, Title V, and Students At Risk Funds for the 2024 - 25 school term. (local consolidated plan)
12. Petty cash funds will include LIPC at \$750, HSPC at \$1125, HSPC #2 at \$875 for a total of petty cash funds of \$2750. (K.S.A. 72-1177)
13. Follow early payment request policy (K.S.A. 12-105b)
14. Authorize the principals to oversee the gate receipts. (K.S.A. 72-1178)
15. Approve the Fees Schedule (K.S.A. 72-3353) for Textbook Rentals (K.S.A. 72-3346).

# USD 212

## Cash Summary Report

Accounting Cycle: FY 23-24; Beginning Period: Period 00 (05/01/2023 - 06/30/2023) ; Ending Period: Period 14 (08/01/2024 - 08/31/2024) ; Show Prior Year Expense/Encumbrance: Transactions after the Last Period: No; Exclude Closing Entries: No; Include Unposted Transactions: No; Created On: 7/4/2024 12:43:14 PM

Fund	Description	Beginning Balance	Revenue	Expenditure	Other	Ending Balance
06	GENERAL FUND	(\$62,989.15)	\$1,776,153.10	(\$1,776,175.26)	\$63,181.15	\$169.84
07	FEDERAL FUNDS	(\$53,716.13)	\$338,388.00	(\$280,971.94)	\$0.00	\$3,699.93
08	SUPPLEMENTAL GENERAL FUND	\$57,755.25	\$595,117.97	(\$646,993.94)	\$19,417.71	\$25,296.99
11	FOUR YEAR OLD AT RISK FUND	\$28,837.05	\$79,388.00	(\$82,130.51)	(\$17,426.00)	\$8,668.54
13	K-12 AT RISK FUND	\$21,877.10	\$303,150.00	(\$271,837.89)	(\$10,323.30)	\$42,865.91
14	BILINGUAL EDUCATION	\$0.00	\$325.00	\$0.00	\$0.00	\$325.00
16	CAPITAL OUTLAY	\$142,741.87	\$633,408.87	(\$323,509.15)	(\$22,273.41)	\$430,368.18
18	DRIVER TRAINING	\$4,999.65	\$1,405.00	(\$4,042.07)	\$0.00	\$2,362.58
24	FOOD SERVICE	\$18,128.31	\$176,488.00	(\$179,311.17)	\$830.00	\$16,135.14
26	PROFESSIONAL DEVELOPMENT FUND	\$922.57	\$11,113.00	(\$7,889.74)	\$6,006.14	\$10,151.97
30	SPECIAL EDUCATION	\$40,403.11	\$352,161.85	(\$320,216.46)	(\$14,892.36)	\$57,456.14
34	VOCATIONAL EDUCATION	\$21,249.54	\$91,788.60	(\$84,359.43)	(\$15,000.00)	\$13,678.71
35	GIFTS/GRANTS	\$57,564.61	\$10,705.01	(\$18,403.79)	\$0.00	\$49,865.83
51	KPERS RETIREMENT CONTRIBUTIONS	\$0.00	\$0.00	\$0.00	\$0.00	\$0.00
53	CONTINGENCY FUND	\$225,000.00	\$0.00	\$0.00	\$0.00	\$225,000.00
55	TEXTBOOK RENTAL	\$36,082.14	\$4,732.59	(\$1,408.55)	\$0.00	\$39,406.18
81	LIBRARY GRANT	\$911.02	\$0.00	\$0.00	\$0.00	\$911.02
85	KS COORDINATED SCHOOL HEALTH	\$1,958.14	\$0.00	\$0.00	\$0.00	\$1,958.14
<b>Sub Total</b>		<b>\$541,725.08</b>	<b>\$4,374,324.99</b>	<b>(\$3,997,249.90)</b>	<b>\$9,519.93</b>	<b>\$928,320.10</b>

No; Prior Year Ending Balance for Beginning Balance: No; Include

<b>Encumbrances</b>	<b>Liabilities</b>	<b>Available</b>
\$0.00	(\$192.00)	(\$22.16)
\$0.00	\$0.00	\$3,699.93
\$0.00	\$0.00	\$25,296.99
\$0.00	\$0.00	\$8,668.54
\$0.00	\$0.00	\$42,865.91
\$0.00	\$0.00	\$325.00
\$0.00	\$0.00	\$430,368.18
\$0.00	\$0.00	\$2,362.58
\$0.00	\$0.00	\$16,135.14
\$0.00	\$0.00	\$10,151.97
\$0.00	\$0.00	\$57,456.14
\$0.00	\$0.00	\$13,678.71
\$0.00	\$0.00	\$49,865.83
\$0.00	\$0.00	\$0.00
\$0.00	\$0.00	\$225,000.00
\$0.00	\$0.00	\$39,406.18
\$0.00	\$0.00	\$911.02
\$0.00	\$0.00	\$1,958.14
<b>\$0.00</b>	<b>(\$192.00)</b>	<b>\$928,128.10</b>

# USD 212

## Cash Summary Report

Accounting Cycle: FY 23-24; Beginning Period: Period 00 (05/01/2023 - 06/30/2023) ; Ending Period: Period 14 (08/01/2024 - 08/31/2024) ; Show Prior Year Expense/Encumbrance: No; Prior Year Ending Balance for Beginning Balance: No; Include Transactions after the Last Period: No; Exclude Closing Entries: No; Include Unposted Transactions: No; Created On: 7/4/2024 12:43:14 PM

Fund	Description	Liabilities (Beginning)	Liabilities (Ending)	Cash Journal Entries	Other Total
06	GENERAL FUND	\$63,185.31	\$192.00	(\$196.16)	\$63,181.15
07	FEDERAL FUNDS	\$0.00	\$0.00	\$0.00	\$0.00
08	SUPPLEMENTAL GENERAL FUND	\$18,396.42	\$0.00	\$1,021.29	\$19,417.71
11	FOUR YEAR OLD AT RISK FUND	\$0.00	\$0.00	(\$17,426.00)	(\$17,426.00)
13	K-12 AT RISK FUND	\$0.00	\$0.00	(\$10,323.30)	(\$10,323.30)
14	BILINGUAL EDUCATION	\$0.00	\$0.00	\$0.00	\$0.00
16	CAPITAL OUTLAY	\$8,703.62	\$0.00	(\$30,977.03)	(\$22,273.41)
18	DRIVER TRAINING	\$0.00	\$0.00	\$0.00	\$0.00
24	FOOD SERVICE	\$22,487.70	\$0.00	(\$21,657.70)	\$830.00
26	PROFESSIONAL DEVELOPMENT FUND	\$6,077.42	\$0.00	(\$71.28)	\$6,006.14
30	SPECIAL EDUCATION	\$0.00	\$0.00	(\$14,892.36)	(\$14,892.36)
34	VOCATIONAL EDUCATION	\$1,242.72	\$0.00	(\$16,242.72)	(\$15,000.00)
35	GIFTS/GRANTS	\$0.00	\$0.00	\$0.00	\$0.00
51	KPERS RETIREMENT CONTRIBUTIONS	\$0.00	\$0.00	\$0.00	\$0.00
53	CONTINGENCY FUND	\$0.00	\$0.00	\$0.00	\$0.00
55	TEXTBOOK RENTAL	\$0.00	\$0.00	\$0.00	\$0.00
81	LIBRARY GRANT	\$0.00	\$0.00	\$0.00	\$0.00
85	KS COORDINATED SCHOOL HEALTH	\$0.00	\$0.00	\$0.00	\$0.00
<b>Sub Total</b>		<b>\$120,093.19</b>	<b>\$192.00</b>	<b>(\$110,765.26)</b>	<b>\$9,519.93</b>

Northern Valley  
USD 212



K – 12 Handbook

Approved by the USD 212 Board of Education on  
July 8, 2024~~132, 2022~~

## **WELCOME TO NORTHERN VALLEY**

Dear Students:

Welcome back for a new school year. The Northern Valley staff, administration, and board of education are committed to providing a positive and safe learning environment for all students. Our goal is for students to be successful in school and life after school. You and your parents are an important part of this educational team. In order for you to be successful you need to come to school ready to learn, go to class on time, work hard to get good grades, and follow the guidelines in this handbook.

The contents of this Student Handbook include important guidelines that help us operate effectively. For K-12<sup>th</sup> grade students, please take the time to review the handbook section of your planner so that all of us have a common understanding of what is expected and operate within those guidelines. This planner also serves as an organizational tool and you are encouraged to use the calendar pages to note assignments, projects and tests you should be prepared for. Because it also serves as a hall pass, it would be beneficial that you carry it with you throughout the day.

Northern Valley Schools will provide you with many opportunities to learn and enjoy your educational experience and we encourage you to get involved academically and socially. Your involvement in various groups or teams will help you to understand how to work with others and will enable you to build positive relationships. Research shows that involvement with activities outside of the classroom helps students with their interest in school and eventual graduation.

We expect students to strive for excellence in their studies and to make positive contributions to our school and our community. Don't take classes just because they are easy, take them because they could be beneficial to your future. As an educational team, we are here to provide the best education possible. You need to remember that you are an equally important part of this team and it is important that you take the responsibility to ask questions and seek extra help when you don't understand.

The cornerstone of any successful school community is the concept of mutual respect for others in the community. We have over 100 teachers, staff, and students sharing an environment at the same time. Therefore, your actions must be consistent with the rules and must not infringe on the rights, safety, and respect for others.

Our hope is that you will always strive to be the best student and person you can be. The Northern Valley Educational Team is looking forward to many successes this coming year. If there is anything that we can help you with as you pursue your educational goals, please let us know. We wish you the best this year and let's show that HUSKY PRIDE!

**GO HUSKIES!**

## **CITIZENSHIP STATEMENT**

**AT NORTHERN VALLEY, I HAVE THE RIGHT...**

**TO BE TREATED WITH RESPECT BY EVERY PERSON,  
TO FEEL SAFE AND TO BE SAFE, TO BE HEARD, REGARDLESS OF WHO I AM,  
TO EXPECT THAT OTHERS WILL RESPECT MY RIGHTS,  
TO EXPECT MY PERSONAL PROPERTY WILL BE RESPECTED,**

**IN RETURN, I HAVE THE RESPONSIBILITY....**

**TO RESPECT THE SPACE, THE PROPERTY, AND THE PERSON OF EVERYONE ELSE,  
TO UNDERSTAND AND TOLERATE DIFFERENCES IN OTHER PEOPLE,  
TO GIVE TO OTHERS ALL THE SAME RIGHTS I DEMAND FOR MYSELF.**

**NO ONE WILL INTERFERE WITH ANYONE ELSE'S RIGHT TO LEARN.**

## **PHILOSOPHY OF EDUCATION**

The Board of Education of Northern Valley Schools, U.S.D. #212, believes that each individual child should be provided with an educational program that is best suited to meet the needs and interests of that individual, and provide opportunity for learning experiences designed to promote behavioral change and maturation that will effect continuing satisfactory adjustment to life.

In practical application of this philosophy, opportunities shall be provided each student to develop individually and to mature to his/her natural limits in terms of his/her own abilities and interest; to develop his or her ability to vote intelligently, hold office, contribute to his economic well-being, keep informed of the changing world and environment around him/her, use his/her leisure time wisely and constructively, and understanding for the necessity of due process.

We, therefore, believe that the development of an educational program should be an evolutionary process under constant evaluation dedicated to providing experiences relevant to the demands of the modern society.

## **NORTHERN VALLEY USD #212 DISTRICT WIDE GOALS**

1. DEVELOP SKILLS IN READING, WRITING, SPEAKING, AND LISTENING.
  - A. Develop ability to communicate ideas and feelings effectively.
  - B. Develop skills in oral and written English.
2. LEARN HOW TO EXAMINE AND USE INFORMATION.
  - A. Develop ability to examine information constructively and creatively.
  - B. Develop ability to use scientific methods.
  - C. Develop reasoning abilities.
  - D. Develop skills to think and proceed logically.
3. DEVELOP SKILLS IN MATHEMATICS AND SCIENCE.
  - A. Develop ability to apply skills in real-life experiences.
  - B. Develop a fund of information and concepts.
  - C. Develop special interests and abilities.
4. DEVELOP GOOD CHARACTER AND SELF-RESPECT.
  - A. Develop moral responsibility and a sound ethical and moral behavior.
  - B. Develop the student's capacity for constructive discipline in work, study, and play.
  - C. Develop moral and ethical sense of values, goals, and processes of free society.
  - D. Develop standards of personal character and ideas.
5. DEVELOP PRIDE IN WORK AND A FEELING OF SELF-WORTH.
  - A. Develop a feeling of student pride in achievements and progress.
  - B. Develop self-understanding and self-awareness.
  - C. Develop the student's feeling of positive self-worth, security, and self-assurance.
6. LEARN HOW TO BE A GOOD CITIZEN.
  - A. Develop an awareness of civic rights and responsibilities.
  - B. Develop attitudes for productive citizenship in a democracy.
  - C. Develop an attitude of respect for personal and public property.
  - D. Develop an understanding of the obligations and responsibilities of citizenship.
7. DEVELOP A DESIRE FOR LEARNING NOW AND IN THE FUTURE.

- A. Develop intellectual curiosity and eagerness for lifelong learning.
  - B. Develop a positive attitude toward learning.
  - C. Develop a positive attitude toward continuing independent education.
8. PRACTICE AND UNDERSTAND THE IDEAS OF HEALTH AND SAFETY.
- A. Establish an effective, individual, physical fitness program.
  - B. Develop an understanding of good physical health and [well-being](#).
  - C. Establish sound personal health habits and information.
  - D. Develop a concern for public health and safety.
9. UNDERSTAND AND PRACTICE DEMOCRATIC IDEAS AND IDEALS.
- A. Develop loyalty to American democratic ideals.
  - B. Develop patriotism and loyalty to ideas of democracy.
  - C. Develop knowledge and appreciation of the rights and privileges in our democracy.
  - D. Develop an understanding of our American heritage.
10. APPRECIATE CULTURE AND BEAUTY IN THE WORLD.
- A. Develop abilities for effective expression of ideas and cultural appreciation – fine art.
  - B. Cultivate appreciation for beauty in various forms.
  - C. Develop creative self-expression through various media - art, music, writing, etc.
11. GAIN INFORMATION NEEDED TO MAKE JOB SELECTIONS
- A. Promote self-understanding and self-direction in relation to student’s occupational interests.
  - B. Develop the ability to use information and counseling services related to the selection of a job.
  - C. Develop knowledge of specific information about a particular vocation.
12. LEARN HOW TO USE LEISURE TIME.
- A. Develop ability to use leisure time productively.
  - B. Develop a positive attitude toward participation in a range of leisure time activities – physical, intellectual, and creative.
  - C. Develop appreciation and interest, which will lead to wise and enjoyable use of leisure time.
13. LEARN HOW TO BE A GOOD MANAGER OF MONEY, PROPERTY, AND RESOURCES.
- A. Develop an understanding of economic principles and responsibilities.
  - B. Develop ability and understanding impersonal buying, selling, and investments.
  - C. Develop skills in management of natural and human resources and the environment.
14. UNDERSTAND AND PRACTICE THE SKILLS OF FAMILY LIVING.
- A. Develop understanding and appreciation of the principles of living in the family group.
  - B. Develop attitudes leading to acceptance of responsibilities as family members.
  - C. Develop an awareness of future family responsibilities and achievement of skill in preparing to accept them.
15. LEARN TO RESPECT AND GET ALONG WITH PEOPLE WITH WHOM WE WORK AND LIVE.
- A. Develop appreciation and respect for the worth and dignity of individuals.
  - B. Develop respect for individual worth and understanding of minority opinions and acceptance of majority decisions.
  - C. Develop a cooperative attitude toward living and working with others.
16. LEARN ABOUT AND TRY TO UNDERSTAND THE CHANGES THAT TAKE PLACE IN THE WORLD
- A. Develop ability to adjust to the changing demands of society.
  - B. Develop an awareness of and the ability to adjust to a changing world and its problems
  - C. Develop understanding of the past, identify with the present, and the ability to meet the future.
17. DEVELOP SKILLS TO ENTER A SPECIFIC FIELD OF WORK.
- A. Develop abilities and skills needed for immediate employment.
  - B. Develop an awareness of opportunities and requirements related to a specific field of work.
  - C. Develop an appreciation of good workmanship.
18. LEARN HOW TO RESPECT AND GET ALONG WITH PEOPLE WHO THINK, DRESS, AND ACT DIFFERENTLY
- A. Develop an appreciation for and an understanding of other people and other cultures.
  - B. Develop an understanding of political, economic, and social patterns of the rest of the world, nations, and cultures.
  - C. Develop awareness of the interdependence of races, creeds, nations, and cultures.
  - D. Develop an awareness of the processes of group relationships.

**AN EQUAL EMPLOYMENT EDUCATION OPPORTUNITY AGENCY**

Northern Valley Schools, U.S.D. #212 does not discriminate on the basis of sex, race, color, national origin, handicap, or age in admissions or access to, or treatment or employment in its programs or activities. Any questions regarding the Department's compliance with Title VI, Title IX, or section 504 may be directed to the Title IX Coordinator, who can be reached at 785-669-2445, 512 W. Bryant, Alma, KS 67622, or to the Assistant Secretary for Civil Rights, U.S. department of Education.

**FACULTY & STAFF**

**OFFICE STAFF**

Ken Tharman ..... Superintendent & HS Principal  
 Marvin Gebhard ..... Pre-K – 8 Principal  
 Amber Brown ..... Clerk  
 Kacie Yocum Kinze Cox ..... Treasurer & HS Secretary  
 Sommer Yocum ..... Junior High Secretary  
 Kenzi Sheley Kenzi Sheley Sheri Sammons ..... Elementary School Secretary

**TEACHING STAFF**

Jim Cole Max Boehler ..... K – 128 PE / Junior High Athletic Director MS Technology  
 Mitch Pugh ..... MS/JH HS Social Science  
 Amy McKinney ..... 9-12 Computers & Business  
 Nita Lewis ??????? Hannah Mongeau ..... 9-12 English / KAY / Student Success Coordinator  
 Jessie Thalheim ..... 5 – 12 Science / HS Activities Director  
 Emily Lowry ..... 6- 12 Math  
 Cindy Mordecai Sarah Rudd ..... HS Voecal & Band / K-12 Music 5 – 12 Band 4 Music / Student Success Coordinator  
 5-12 Instrumental / HS Technology  
 Ellen Kuhl Cindy Mordecai ..... 6-8 Language Arts / 5K – 8 Voecal & Band  
 Ross Cole ..... 9 – 12 PE / HS Technology  
 ????????? Ed Schurman Alissa Krafft ..... 9-12 Vocational Agriculture & FFA / FACS  
 Katie Grote ..... K – 4 Title Jessica Reeves 9-12 Science / Student Success Coordinator  
 Suzanne Brooks Sandra Dole ..... Preschool  
 Shelby Preston Angie Knuth ..... Kindergarten  
 Angela Knuth Tammy Vincent ..... First Grade  
 Melinda Davis Katie Grote ..... Second Grade  
 Jill Gebhard ..... Third Grade  
 Amy Chandler ..... Fourth Grade  
 Kirsten Baird ..... Fifth Grade  
 Kelli Hueneke ..... 5 PreK-6<sup>th</sup> Title I / 6-8 Social Studies / At Risk  
 Terry Logemann ..... 5-12 Interrelated Teacher  
 Adriana Ankenman Tami Dubois ..... K-4<sup>th</sup> Interrelated Teacher  
 John Vincent ..... Library Media Tech  
 Brandi Shelton ..... Nurse  
 Ryan Hopkins ..... Technology Coordinator

**CUSTODIANS**

**CAFETERIA STAFF**

Noah Hansen Alan Brown Hal Hansen (ES) ..... Becky Delimont, Food Service Supervisor & Cook  
 Silvia Marquez Cassandra Speer & Laurie Alsdurf ????????? (JH) ..... Monica Bach, Cook  
 ????????? Noah Hansen (HS / Alma Maint.) ..... Jacque Horacek, Cook  
 Dean Lewis – Maintenance Director

**BOARD MEMBERS**

Hilary Van Patten ..... Laquita Smith  
 Christopher Rogers ..... Shanna Hammond  
 Rich Wenzl ..... Steven Whitney

**SCHOOL TELEPHONE NUMBERS**

Alma High School – 785-669-2445  
 Long Island Junior High School – 785-854-7681

Almena Elementary School – 785-664-2446

#### **WEBSITE**

The districts website offers a wealth of information about the district including articles of school events happening K-12. Make sure you regularly visit: [www.nvhuskies.org](http://www.nvhuskies.org)

#### **SCHOOL CLOSING/STORM ROUTES**

Listen to the following stations for school closings during stormy weather:

KQNK – Norton Radio – AM 1530/FM 106.7

KKAN/KQMA – Phillipsburg Radio – AM 1490/FM92.5

KRVN – Lexington Radio – AM 880/FM 93.1

KSNK – TV Channel 8

NTV – TV – Channel 13

KOLN – TV – Channel 11

KAKE – TV – Channel 10

KWCH – TV – Channel 7

#### **HANDBOOK PURPOSE**

A handbook exists for those who need to have guidelines and rules written down and for those times when we all need to have a reference to look up information about the school.

The content of the handbook has been determined by what students and faculty need. This handbook has been approved by the USD 212 Board of Education and is an extension of district policy.

#### **PLANNER USE**

9<sup>th</sup>-12<sup>th</sup> planners will be used when students are missing part of or all of two or more class periods a day for school activities. When a student is going to be gone to a school event or activity and will miss part of or all of two or more class periods, the student is required to get the planner signed by the teacher from each class they will be missing. Students will then present their planner to the sponsor or coach prior to leaving (procedure for checking planners will be determined by the coach or sponsor). This is to insure students are not missing assignments as a result of school related activities. Failure to do any of these steps will result in the student being unable to attend the event or activity. Teachers should only sign planners when students have completed the work they will be missing or have made arrangements with the student to make up missed work.

#### **PASSES OR PERMITS**

6<sup>th</sup>-12<sup>th</sup> Students must have a signed pass when they are in the halls during class time. It is preferred that students use the hall passes in their planners. Permits and special passes for yearbook and teacher assistants may be made by the teachers or sponsors. **A student leaving the building or school grounds must have permission from the office.**

#### **INCLUSION STATEMENT**

Areas of concern not specifically addressed in this book are not to be assumed as permitted. In other words, it may not be written down here, but that doesn't imply it is allowed.

#### **FRIABLE ASBESTOS CONTAINING MATERIAL**

All Friable Asbestos-containing materials have been removed from Northern Valley Schools. Any remaining Asbestos is in a non-friable state.

In accordance with EPA Rules and Regulations, all non-friable material will be repaired as it deteriorates or it is physically damaged. If anyone would like more information regarding the specific location of this material, or a copy of the EPA regulations relevant to this matter, you may contact the office of the Superintendent of Schools at 512 W. Bryant, Almena, Kansas.

#### **STUDENT GRIEVANCE PROCEDURES**

The Board of Education has adopted the following resolution relating to Grievance Procedures, which includes the American with Disabilities Act:

- A. The Local Education Agency recognizes the right of students to express their grievances, and to seek a solution concerning disagreements arising from differences of interpretation of policy, which might arise between the LEA and its students.
- B. The procedures for processing grievances shall be as follows:

1. Should a grievant or the representative find, after oral discussion with the principal, that Grievant rights under LEA Policy have been violated, they may originate a grievance. The grievant and/or the representative shall, within 20 days of the date the grievance occurred, present the facts, in writing, to the principal. The decision of such official shall be made in writing, to the grievant within ten (10) working days.
2. Should the grievant decide that the reply of the principal is unsatisfactory, the grievant shall, within ten (10) working days, submit an appeal to the chief school officer. The decision of the chief school officer shall be made in writing, to the grievant or the representative within ten (10) working days.
3. Should the grievant decide the reply of the chief school officer is unsatisfactory, the matter may be appealed, within ten (10) working days, to a grievance Committee which shall be established as follows:
  - a. The grievant or the representative may designate one (1) member.
  - b. The chief school officer or the representative shall appoint one (1) member.
  - c. The two members appointed, as provided in (a) and (b) above, shall agree upon a third member.
  - d. In the event the grievant representative and the LEA representative cannot agree upon a third member of the Grievance committee within a period of ten (10) working days the President of the local board shall designate a third member.
  - e. The Grievance Committee as provided in "c", shall meet within a period of ten (10) working days after the appointment of the third member of the Committee and a set decision of the grievance Committee may be reached upon the concurrence of any two (2) of the three members.
  - f. The Grievance Committee shall keep a complete record of any hearing before it, including any exhibits or papers submitted to it in connection with the hearing and a complete transcript of any testimony taken. Upon rendering its decision, the complete record shall be filed in the office of the chief school officer and shall be available to the grievant, the Grievant representative or the LEA's representative.
4. In the event the decision of the grievance Committee is unsatisfactory to either the grievant or the chief school officer, either may, within ten (10) days after receipt of the decision of the grievance committee, file a written notice of appeal to the Local Board of Education.
5. Upon receipt of the notice of appeal, the President of the local board shall cause the transcript of the hearing before the Grievance committee to be filed with the local Board of Education who shall review such record. The decision of the local board of Education, upon such review, shall be final.
6. If the decision is deemed unsatisfactory by the complainant(s), a complaint of alleged Discrimination may be filed with the:

Kansas Commission of Civil Rights  
214 West 6<sup>th</sup>  
Topeka, KS 66603

Equal Employment Opportunity  
12 Grand Building  
1150 Guard  
Kansas City, MO 64106

Department of Health, Education  
and Welfare  
Office for Civil Rights  
324 East 11<sup>th</sup> St  
Kansas City, MO 64106

#### **ADA, OCR, VOC/ED GUIDELINES**

Civil Right Comprehensive Notification for Northern Valley Schools

In compliance with the Executive Order 11246; Title II of the Education Amendments of 1976; Title VI of the Civil Rights Act of 1964, as amended by the Equal Employment Opportunity Act of 1972; Title IX Regulation Implementing Education Amendments of 1972; Section 504 of the Rehabilitation Act of 1973; ADA, and all other Federal, State, School Rules, laws, regulations, and policies, the Northern Valley Schools, Almena, Kansas 67622, shall not discriminate on the basis of sex, race, color, national origin, or handicap in the educational programs or activities, which it operates.

It is the intent of Northern Valley Schools, Almena, Kansas 67622, to comply with both the letter and spirit of the law in making certain discrimination does not exist in its policies, regulations, and operations. Grievance procedures for Title IX and Section 504 have been established for students, their parents, and employees who feel discrimination has been shown by the local education agency.

Specific complaints of alleged discrimination under ACA, Title IX (sex) and Section 504 (handicap) should be referred to:

TITLE IX COORDINATOR	SECTION 504 & ADA COORDINATOR
Ken Tharman	Ken Tharman
Almena, KS 67622	Almena, KS 67622
785-669-2445	785-669-2445

ADA, Title VI, Title IX, and Section 504 complaints can also be filed with the Regional Office for Civil Rights. Address Correspondence to:

Regional Office for Civil Rights  
324 East 11<sup>th</sup>  
Kansas City, MO 64106

All students attending Northern Valley Schools, Almena, KS 67622 may participate in education programs and activities, including, but not limited to health, physical education, music, and vocational and technical education regardless of race, color, national origin, age, handicap, or sex.

#### **KANSAS STATE DEPARTMENT OF EDUCATION COMPLAINT RESOLUTION PROCEDURES**

Under 34 CFR 299.10 to 299.12;

1. Any organization or individual may file a written, signed complaint with the Commissioner of Education, 120 East Tenth Street, Topeka, KS, 66612, alleging that the state or a school district or consortium of school districts is violating a federal statute or regulation that applies to any of the following programs:
  - Part A of Title I (Improving Basic Programs Operated by Local Education Agencies),
  - Part B of Title I (Even Start Family Literacy Programs),
  - Part C of Title I (Migrant Education),
  - Part D of Title I (Children and Youth Who are Neglected, Delinquent, or At-Risk of Dropping Out),
  - Title II (Eisenhower Professional Development Program),
  - Subpart 2 of Part A of Title III (State and Local Programs for School Technology Resources),
  - Part VI (Innovative Education Program Strategies),
  - Part C of Title VII (Emergency Immigrant Education), and
  - National and Community Service Trust Act of 1993 and subsequent reauthorization.
2. Any organization or individual also may appeal a decision by a local school district or consortium of school districts regarding an alleged violation of federal statute or regulation that applies to the above listed programs. The appeal must be written and signed by the appellant and contain the information described in paragraph 3. The appeal shall be filed with the Commissioner of Education within 30 days of the date of the local decision.
3. Any complaint or appeal must include:
  - (a) A statement that the state or a sub-grantee has violated a requirement of a federal statute or regulation that concerns a covered program.
  - (b) the facts on which the statement is based; and
  - (c) the specific requirement allegedly violated.
4. Upon receiving a complaint or appeal meeting the above requirements, an investigation shall be made to determine the merits of the complaint or appeal. This may include the conduct of an on-site investigation, if it is determined that an on-site investigation is necessary.
5. Each complaint or appeal shall be investigated and resolved within 60 calendar days after it is received. However, if the Commissioner determines that exceptional circumstances exist with respect to a particular complaint or appeal, an extension of the time may be granted.
6. Any person who is dissatisfied with a final decision of the Commissioner regarding a complaint or an appeal shall have the right to request the Secretary of the U.S. Department of Education to review the decision.

#### **EMERGENCY SAFETY INTERVENTIONS**

[Policy may be found on the school website/ documents/district information](#)

**SUGGESTED PROCEDURES FOR COMPLAINT RESOLUTION AT THE LOCAL EDUCATION AGENCY LEVEL**

Area of Concern	First Level	Second Level	Third Level	Fourth Level	Fifth Level
Athletics	<b>Coach</b>	<b>Athletic Director</b>	<b>Principal</b>	<b>Supt.</b>	<b>Board of Education</b>
Curriculum/Academic / Instruction	<b>Teacher</b>	<b>Principal</b>	<b>Supt.</b>	<b>Board of Education</b>	
Discipline	<b>Teacher</b>	<b>Principal</b>	<b>Supt.</b>	<b>Board of Education</b>	
Facilities	<b>Principal</b>	<b>Supt.</b>	<b>Board of Education</b>		
Guidance	<b>Student Success Coord.</b>	<b>Principal</b>	<b>Supt.</b>	<b>Board of Education</b>	
Special Education	<b>Teacher</b>	<b>Principal</b>	<b>NCKSEC</b>	<b>Supt.</b>	<b>Board of Education</b>
Student Concerns	<b>Teacher</b>	<b>Principal</b>	<b>Supt.</b>	<b>Board of Education</b>	
Computer / Technology	<b>Teacher</b>	<b>Technology Director</b>	<b>Principal</b>	<b>Supt.</b>	<b>Board of Education</b>
Transportation	<b>Driver</b>	<b>Transportation Director</b>	<b>Principal</b>	<b>Supt.</b>	<b>Board of Education</b>
Custodial / Maintenance	<b>Principal</b>	<b>Supt.</b>	<b>Board of Education</b>		

1. The complainant is encouraged to first speak to the teacher or staff person involved.
2. If the concern is not resolved through direct communication, the complainant is encouraged to speak with the principal of the school. Principals have 10 calendar days to respond to concerns, which may include an in - person conference if requested by any involved party. If the concern is not resolved to the complainant’s satisfaction, the principal shall inform the complainant to the superintendent.
3. The Superintendent will have 10 calendar days to respond to the concern, the complaint must include, the facts on which the statement is based; and the specific requirement allegedly violated.
4. Upon receiving a complaint or appeal meeting the above requirements, an investigation shall be made to determine the merits of the complaint or appeal. This may include conducting of an on-site investigation, if it is determined that an on-site investigation is necessary.
5. Each complaint or appeal shall be investigated and resolved within 60 calendar days after it is received. However, if the Superintendent determines that exceptional circumstances exist with respect to a particular complaint or appeal, an extension of the time may be granted.
6. Any person who is dissatisfied with a final decision of the Superintendent regarding a complaint or an appeal shall have the right to request placement on the Board of Education Agenda to review the decision.

**POLICY OF PROOF OF IDENTITY OF STUDENTS**

Kansas’s law provides that whenever a child enrolls in a public school for the first time, the school is required to secure proof of identity of the child. Proof of identity is either, (a) a birth certificate for a child enrolling in Kindergarten or first grade, (b) a copy of the court order placing the child in the custody of the Social and Rehabilitation Services or, (c) a certified transcript or other similar pupil record of a child enrolling in grades 2 through 12.

If proof is not provided to the school within 30 days of enrollment, the school must notify the law enforcement agency, which must promptly investigate the identity of the child.

#### **CHILD HEALTH ASSESSMENT FOR NEW SCHOOL ENTRANTS**

Effective May 5, 1994, Child Health Assessments will be required as follows:

1. Applies to new school entrants (not previously enrolled in any school in Kansas).
2. Applies to both public and private schools.
3. Applies to children ages 8 and under. This would include preschool children enrolling in school for the first time.
4. The health assessment definition includes: health history, physical exam, and other screening tests as medically indicated. The provider determines which lab and other screening tests will be done.
5. No specific health assessment form is required. A sample form can be obtained by phoning 785-296-1217.
6. Qualified providers include physicians, other providers working under direct supervision of physicians or nurses certified by KDHE. Questions regarding nursing certifications should be addressed to KDHE at 785-296-6651.
7. Health assessment information should be forwarded to the school by the parent/guardian.
8. The health assessment must be done within 12 months prior to school entry or within 90 days after school entry. A student may be excluded from school without the health assessment.
9. When provided to a Medicaid participant child, Medicaid requires certain tests be done as part of the Kan-BE-Healthy program. Questions: Contact DCF at 785-296-1491.

#### **USD 212: DRUG FREE SCHOOLS AND COMMUNITIES ACT**

The unlawful possession, use, or distribution of illicit drugs and alcohol by students or school employees on school premises or as a part of any school activity is prohibited. This policy is required by the 1989 amendments to the Drug Free School and Communities Act, PL 102-226. This policy, and any curriculum used in conjunction with it, shall be evaluated at least every other year using criteria developed by the superintendent and approved by the board. The board shall receive a report after each of these reviews is conducted (Approved: July 17, 1990).

The entire district's students shall be made aware of the legal, social, and health consequences of drug and alcohol use. Students shall be instructed on effective techniques for resisting peer pressure to use illicit drugs or alcohol. Students shall also be informed that the use of illicit drugs and the unlawful possession and use of alcohol is both wrong and harmful.

The board has adopted a comprehensive drug and alcohol abuse and prevention program as part of the district's curriculum. The curriculum is age-appropriate and developmentally based to reach students at all ages and levels of education within the district.

#### **TOBACCO POLICY Tobacco Free Campus**

Use and/or possession of any tobacco product or nicotine delivery device is prohibited in any district facility; in school vehicles; at school-sponsored, activities, programs, or events; and on school owned or operated property.

Student violations may result in parent/guardian notification, participation in tobacco education program, suspension and/or expulsion from school and/or extracurricular activities, community service, and/or notification of law enforcement.

The following definitions apply to this policy.

"Nicotine delivery device" means any device that can be used to deliver nicotine or nicotine salts to the person inhaling from the device. Such definition shall include, but may not be limited to, any electronic cigarette, cigar, cigarillo, pipe, or personal vaporizer.

"Tobacco product" means any product that is made from or derived from tobacco, or that contains nicotine, that is intended for human consumption or is likely to be consumed, whether smoked, heated, chewed, absorbed, dissolved, inhaled or ingested by any other means, including, but not limited to, a cigarette, a cigar, pipe tobacco, chewing tobacco, snuff, or snus.

"Tobacco product" also means any component or accessory used in the consumption of a tobacco product, such as filters, rolling papers, pipes, and substances used in electronic cigarettes, whether or not they contain nicotine.

Visitors who are not district employees or students will be prohibited from using tobacco in and on all district real or personal property, whether owned, leased, or rented, or at any school sponsored event. If the visitor does not comply he or she will be asked to leave the school property for the rest of the day. If the visitor refuses to cease using tobacco products or refuses to leave, they should be advised that continued refusal to leave school property may be referred to local law enforcement. The law enforcement authority may be called to deal with the person and a complaint may be filed with the local law enforcement agency. **All staff members are expected to assist in the enforcement of this policy.**

All students are prohibited from illegally possessing, smoking, or otherwise using tobacco products in or on all district real or personal property, whether owned or leased, or rented, or at any school sponsored event. This policy became effective on July 8, 2019. It shall be in effect twenty-four hours a day, seven days a week, without exception.

**STUDENT SUBSTANCE ABUSE POLICY**

As a condition of continuous enrollment in the district, students shall abide by the terms of this policy.

Students shall not unlawfully manufacture, distribute, dispense, possess, or use illicit drugs, controlled substances, or alcoholic beverages on school district property or at any school activity. Any student violating the terms of this policy will be reported to the appropriate law enforcement officials and will be subject to the following sanctions:

- (1) First Offense. A first time violator shall be subject to the following sanctions:
  - (a) A punishment up to and including short term suspension;
  - (b) Suspension from all student activities for a period of one competition.
- (2) Second Offense. A second time violator shall be subject to the following sanctions:
  - (a) A punishment up to and including long term suspension;
  - (b) Suspension from all student activities for a period of not less than two months.
  - (c) A student placed on long-term suspension under this policy may be readmitted on a probationary status if the student agrees to complete a drug and alcohol rehabilitation program. **Name(s) of the acceptable programs are on file with the board clerk.** If at any time the student fails to make satisfactory progress in the program, the suspension shall be imposed.
- (3) Third and Subsequent Offenses. A student who violates the terms of this policy for the third time, and any subsequent violations, shall be subject to the following sanctions:
  - (a) A punishment up to and including expulsion from school for the remainder of the school year;
  - (b) Suspension from participation in and attendance at all school activities for 18 weeks.
  - (c) A student who is expelled from school under the terms of this policy may be readmitted during the term of the expulsion only if the student has completed a drug and alcohol education and rehabilitation program at an acceptable program.

Students who are suspended or expelled under the terms of this policy will be afforded the due process rights contained in board policies and Kansas statutes, K.S.A. 72-6114, et seq. Nothing in this policy is intended to diminish the ability of the district to take other disciplinary action against the student in accordance with other policies governing student discipline. In the event a student agrees to enter into and complete a drug education or rehabilitation program, the cost of such program will be borne by the student and his or her parents. Drug and alcohol counseling and rehabilitation programs are available for students of the district. A list of available programs along with names and addresses of contact persons for the program is on file with the board clerk. Parents or students should contact the directors of the programs to determine the cost and length of the program.

A copy of this policy and available counseling and rehabilitation programs will be provided to all students and the parents of all students. Parents of all students will be notified that compliance with this policy is mandatory.

**AVAILABLE DRUG PROGRAMS**

<b>Valley Hope Alcoholism Treatment Center</b> Main Office W. Hwy 36 Norton, KS 67654 785-877-5101	<b>High Plains Mental Health</b> Norton Office 211 S. Norton Norton KS 67654 785-877-5141
--	---

<b>High Plains Mental Health</b> Phillipsburg Office 783 7 <sup>th</sup> Street Phillipsburg, KS 67661 785-543-5284	<b>High Plains Mental Health</b> Center 208 E. 7 <sup>th</sup> St. Hays, KS 67601 785-628-2871 or 1-800-432-0333
---	--

**USD 212: SEXUAL HARASSMENT POLICY**

**GENERAL POLICY:** USD #212 is committed to providing a positive learning and working environment for its students and employees and will not tolerate sexual harassment or sexual violence. Sexual harassment is illegal and will not be tolerated in the school district. It is a violation of Title VII of the Civil Rights Act of 1964, and Title IX of the Education Amendments of 1972, and may constitute sexual abuse under Kansas’s statutes. This policy applies to males and females, and includes same sex harassment. This policy is applicable to students while on school premises and while participating in off-campus school sponsored activities. Sexual harassment of employees or students of the district by board members, administrators, certified and support personnel, students, vendors, and any others having business or other contact with the school district is strictly prohibited. It shall be a violation of this policy for an employee to sexually harass a student, for a student to sexually harass another student, or for an employee to discourage a student from filing a complaint or to fail to investigate or refer for investigation, any complaint lodged under the provisions of this policy.

**DEFINITION:** Sexual harassment is unwelcome sexual advances, requests for sexual favors, or other inappropriate oral, written, or physical conduct of a sexual nature when: (1) submission to such conduct is made, explicitly or implicitly, a term or condition of an individual’s education; (2) submission to or rejection of such conduct by an individual is used as a basis for academic decisions affecting that individual; or (3) such conduct has the purpose or effect of interfering with an individual’s academic or professional performance or creating an intimidating, hostile or offensive academic environment.

Sexual harassment is demeaning and degrading. It affects an individual’s self-esteem, and can have a negative impact on performance at work or in class. It can make an individual feel angry, powerless, and fearful. Sexual harassment may include, but is not limited to: verbal or written harassment or abuse, including teasing, jokes, posters, pictures or cartoons; pressure for sexual activity; repeated brushing against another’s body; suggesting or demanding sexual involvement accompanied by implied activities, sexual assault or battery as defined by current law. The fact that someone did not intend to sexually harass an individual is generally not considered a defense to a complaint of sexual harassment. In most cases, it is the effect and characteristics of the behavior that determine if the behavior constitutes sexual harassment. When acts of sexual harassment or other violations of this policy are substantiated, appropriate action will be taken against the individual. Disciplinary actions, which could be taken, include, but are not limited to: reprimand, probation, suspension, loss of eligibility to participate in extra-curricular activities, or other sanctions as determined appropriate. Individuals who harass may be held personally liable under civil suits.

**REPORTING INCIDENTS:** Anyone may seek advice, information, or counseling on matters related to sexual harassment without having to lodge a formal complaint. Most complaints can be resolved through informal procedures. Informal procedures are aimed at stopping the behavior rather than determining guilt. Informal complaints do not have to be in writing and are generally not investigated in depth. The intent of the informal reporting procedure is to provide a simple procedure for a person to lodge a complaint and have it quickly looked into and has the offending behavior stopped. Informal resolution of sexual harassment is strictly voluntary on the part of the complainant.

Any student may elect to file a formal complaint under the district’s discrimination complaint procedure. Official disciplinary action cannot be taken without a formal hearing. Formal complaints must be put in writing and normally addressed to the building principal or compliance coordinator. Every individual has the right to bypass the normal reporting chain to report sexual harassment directly to the District School Board Office or the Office of Civil Rights.

The confidentiality of the reporting party will be observed to the utmost provided it does not interfere with the ability to investigate the alleged harassment or to take corrective action.

Retaliation against anyone reporting or thought to have reported sexual harassment behavior is prohibited. The filing of a complaint or otherwise reporting sexual harassment will not reflect upon the individual’s status nor will it affect grades, future employment or assignments. Such retaliation shall be considered a serious violation of the policy and shall be independent of whether a charge or informal complaint of sexual harassment is substantiated.

Encouraging others to retaliate also violates this policy. Examples of retaliation are: ridicule, threats, name-calling, withholding of normal disseminated information, an adverse effect on eligibility status, grades, or further harassment.

All complaints of sexual harassment are taken seriously. The bringing of false charges will be treated as a serious offense. The following steps should be followed when lodging an informal complaint:

1. Any student who believes he or she has been subjected to sexual harassment should report the problem to the principal, guidance counselor, or another certified staff member. Any student may report the harassment directly to the superintendent or a school board member.
2. The person seeking information will be counseled as to the options for action available under this policy and will be provided a copy of this policy. They will be informed about resources available, such as videos or books, which provide information regarding sexual harassment. They will be informed that they will have the opportunity to participate in decisions regarding the method of resolving the matter.
3. Informal resolution will be attempted. Resolution may be as simple as conducting refresher training, having a discussion with the alleged offender, or sending a memo to all students indicating concern about sexual harassment in the district. The alleged offender will not be contacted without permission of the complainant.
4. If the problem is resolved informally, a written summary will be made and kept in a confidential file. The compliance coordinator will follow up within one month to determine whether the victim has been subjected to any further sexual harassment or retaliation.
5. If the problem cannot be resolved informally, or is not resolved within five workdays, the complainant will be advised of formal complaint procedures. The filing of a written complaint is required for a matter to be formally investigated. Formal sexual harassment complaints will be in accordance with the district's discrimination complaint procedure.

Any questions regarding the USD #212 Sexual Harassment Policies should be addressed to the Superintendent, 512 W. Bryant, Almena, KS 67622 (phone 785-669-2445).

#### **ANNUAL NOTIFICATION FAMILY EDUCATIONAL RIGHTS AND PRIVACY ACT**

The Family Educational Rights and Privacy Act (FERPA) affords parents and students over 18 years of age ("eligible students") certain rights with respect to the student's education records. These rights are:

(1) The right to inspect and review the student's education records within 45 days of the day the School receives a request for access.

Parents or eligible students should submit to the School principal [or appropriate school official] a written request that identifies the record(s) they wish to inspect. The School official will make arrangements for access and notify the parent or eligible student of the time and place where the records may be inspected.

(2) The right to request the amendment of the student's education records that the parent or eligible student believes are inaccurate.

Parents or eligible students may ask the School to amend a record that they believe is inaccurate. They should write the School principal [or appropriate school official], clearly identify the part of the record they want changed, and specify why it is inaccurate. If the School decides not to amend the record as requested by the parent or eligible student, the School will notify the parent or eligible student of the decision and advise them of their right to a hearing regarding the request for amendment. Additional information regarding the hearing procedures will be provided to the parent or eligible student when notified of the right to a hearing.

(3) The right to consent to disclosures of personally identifiable information contained in the student's education records, except to the extent that FERPA authorizes disclosure without consent.

One exception, which permits disclosure without consent, is disclosure to school officials with legitimate educational interests. A school official is a person employed by the School as an administrator, supervisor, instructor, or support staff member (including health or medical staff and law enforcement unit personnel); a person serving on the School Board; a person or company with whom the School has contracted to perform a special task (such as an attorney, auditor, medical consultant, or therapist); or a parent or student serving on an official committee, such as a disciplinary or grievance committee, or assisting another school official in performing his or her tasks.

A school official has a legitimate educational interest if the official needs to review an education record in order to fulfill his or her professional responsibility.

Upon request, the School discloses education records without consent to officials of another school district in which a student seeks or intends to enroll.

(4) The right to file a complaint with the U.S. Department of Education concerning alleged failures by the *School District* to comply with the requirements of FERPA. The name and address of the Office that administers FERPA are: Family Policy Compliance Office; U.S. Department of Education; 400 Maryland Avenue, SW; Washington, DC 20202-590

#### **DISCLOSURE OF DIRECTORY INFORMATION UNDER FERPA**

Schools may disclose, without consent, "directory" information such as a student's name, address, telephone number, date and place of birth, honors and awards, and dates of attendance. However, schools must tell parents and eligible students about directory information and allow parents and eligible students a reasonable amount of time to request that the school not disclose directory information about them. If you do not want your student's directory information released, please notify your local school district office of your desire to "opt out".

#### **SPECIAL EDUCATION INFORMATION**

This school district and the North Central Kansas Special Education Cooperative (NCKSEC) work together to identify every student, age birth through 21, living within the district boundaries, that has developmental delays or may be in need of special education. If you have a child or know of a child who you think has development delays or special needs, contact the administrator in your district or [Cher Greving Deb-Reha](#), Director for the NCKSEC at 205 F St. Suite 235; PO Box 369; Phillipsburg, KS 67661 (785-543-2149).

Areas of special education include: birth through age two (infant-toddler), early childhood - disability, developmentally delayed, visual impairments including blindness, hearing impairments including deafness, deaf-blindness, autism, traumatic brain injury, emotional disturbance, specific learning disabilities, mental retardation, multiple disabilities, orthopedic impairments, other health impairments, speech or language impairments, and gifted.

Parents are advised that all special education services are designed to offer the utmost in educational opportunities for each qualifying student, as well as to provide assistance and support in the areas of physical, mental, emotional, and social growth. State and federal laws are followed in providing each student with a free appropriate public education in the least restrictive environment. If you have a child or know of a child who may need special education services please notify the school district or the NCKSEC.

#### **BUILDING AND SCHOOL PROPERTY**

Your parents and community are spending money to provide you with excellent buildings and equipment so you may secure a sound education. Let's do all we can to pass it on to other students in as good a condition as we found it.

Fully respect the property of our neighbors – use the walks at all times. Do not cut across school lawns or those of our patrons. Proper disposal of waste materials will help our custodians and assure us of clean looking buildings and campus. Desks, walls or other school property deliberately defaced will be repaired or replaced at the offending student's expense.

When school is not in session or a sponsored activity is not being held, students will not be allowed to use any school facility without being accompanied by a responsible adult.

Any tables, books, walls, magazines or other school property deliberately cut, marked or otherwise defaced will be repaired at the student's expense.

#### **ENTERING AND LEAVING THE BUILDING AND SCHOOL SCHEDULE**

School will begin at 8:00 AM in both Long Island & Almena and end at 4:00 PM. ~~If students live more than 2.5 miles from the school, bus transportation can be arranged at enrollment.~~ Buses will pick students up and drop them at their attendance center; therefore, more than one bus may stop at your residence.

Students eating breakfast may enter the building at 7:40 a.m. in Almena and Long Island. Breakfast will be served until 5 minutes before the start of school. Any student not eating breakfast may enter the buildings at 7:40 a.m. Upon your arrival at the school grounds, the rules of common decency and socially acceptable behavior should be practiced during your attendance. Any student who for any reason needs to enter the building earlier should make arrangements with the principal or with a teacher.

Students will not remain in the building after school hours unless accompanied by an approved adult supervisor.

#### **ORGANIZATION**

The Northern Valley Schools shall be organized under a PreK-5-3-4 plan offering grades PreK-4 at the Almena Elementary Center, grades 5-8 at the Long Island Middle School Center and grades 9-12 at the Northern Valley High School Center at Almena.

#### **AGE OF ENTRANCE**

Students will be admitted to three-year old Preschool who have reached the age of three years on or before Sept. 1 of the school year or four years on or before Sept. 1 of the school year for the four-year old Pre-school. The four year olds must also have an assessment done before the first day of school.

Students will be admitted to Kindergarten upon presentation of a Birth Certificate verifying that they have attained the age of five years on or before August 31 of the year of entrance.

Students will be admitted to First Grade who have reached the age of six years on or before August 31 of the school year, or who have successfully completed a Kindergarten program maintained by a public school district.

The following exceptions in age of entry requirements for students of U.S.D. #212 became effective 7/1/81 in compliance with House Bill 2186:

1. A child who was a resident of another state and who attained the age of eligibility to attend Kindergarten in such state will be allowed to attend Kindergarten, regardless of age.
2. A child who was a resident of another state and who had attained the age of eligibility to enter the first grade in that state or had completed a kindergarten course in such state (maintained by a public school district or an accredited private, denominational or parochial school), will be eligible to attend the first grade regardless of age.

It will be the responsibility of the parents or legal guardians of the student to provide documented evidence to the Superintendent of School of U.S.D. #212 that the student would be eligible for Kindergarten or First grade in the state in which the student previously resided.

#### **HS SCHEDULING OF CLASSES**

It is the responsibility of the student to keep a continual check with the principal and counselor at the time of enrollment in regard to the meeting of all requirements for graduation upon reaching the fourth year of high school.

Students will need to score at the acceptable level on the ACT and / or Accuplacer test(s) before enrolling in advanced placement classes.

All regularly enrolled high school students are required to carry six subjects each grading period classified as solid subjects. Band and vocal music are not considered as solid subjects.

Students shall be classified at the opening of the school year according to the number of unit credits successfully completed at the time of classification.

- \*Senior shall have successfully completed a minimum at 18 units.
- \*Juniors shall have successfully completed a minimum of 12 units.
- \*Sophomores shall have successfully completed a minimum of 6 units.
- \*Freshman shall have successfully completed the eighth grade.

#### **REQUIREMENTS FOR GRADUATION FROM NORTHERN VALLEY HIGH SCHOOL**

Requirements for Graduation from Northern Valley High School Starting with the class of 2020.

In order to receive a Northern Valley High School Diploma, students must now earn 25 units. Minimum requirements for graduation from Northern Valley High School will reflect standards set by the Kansas State Department of Education and by the Board of Education of Northern Valley Unified District #212 as outlined below:

1. Four (4) units of English language arts, three units will be in English. When, in the judgment of the high school principal, a pupil can profit more by taking another subject, the principal may waive up to one unit of this requirement.
2. Three (3) units of Social Studies is required which must include: United States History, World History, and one unit of United States Government including the constitution of the United States.
3. Three (3) units of Science, including one unit as a laboratory course. Earth Science and Biology plus one (1) unit of any of the following: Physics, Chemistry, Environmental Science, Anatomy and Physiology, Plant Science, Food Science, or Plant and Animal Science.
4. Three (3) units of Math. Prerequisite class Business Essentials to be completed prior to Accounting classes.
5. One (1) unit of Physical Education, which will include one-half unit of health, safety, first aid, or physiology. This requirement shall be waived: (a) upon statement by a licensed physician that a pupil is mentally or physically incapable of participating in a regular modified physical education program; or, (b) when the requirement is contrary to the religious teachings of the pupil. A written statement, signed by a legal guardian of the pupil, shall be filed with the proper authorities of the school, requesting that the pupil not be required to participate in the activities, and stating the reason for the request.
6. Two (2) units of a technology based course including Computer Applications. The second unit chosen from Emerging Technology, Web Design, Video Production or Advanced Computer Applications.
7. One (1) unit of Fine Arts

8. Two (2) units of Career Exploration, Business Essentials, Introductions to Agriculture and Introduction to Family and Consumer Science

A total of 25 units are required for graduation.

Students shall have completed the following courses:	
<b>9th Grade</b> English I – 1 credit Earth Science – 1 credit PE/Wellness – 1 credit - Algebra I – 1 credit Graphic Design – 1 credit Business Essentials -1 credit Intro to Human Services – ½ credit Intro to Agriculture – ½ credit	<b>10th Grade</b> English II – 1 credit Biology – 1 credit World History – 1 credit Geometry – 1 credit Technology elective – 1 credit (can be taken during 10th, 11th or 12th grade)
<b>11th Grade</b> American History – 1 credit English III – 1 credit Science elective – 1 credit Algebra II – 1 credit	<b>12th Grade</b> Government – 1 credit English IV/English Comp. – 1 credit
<b>9th-12th Grade</b> A minimum of 7 additional electives – (1 must be fine arts)	

Enrollment team must include student, parent or guardian, counselor, and administrator. All team members **must** be present in order for freshmen to enroll or for sophomores, juniors or seniors to make changes to their graduation plan. At enrollment guidance must be given on NVHS graduation requirements, state graduation requirements, and KBOR qualified admissions and scholarship requirements. A graduation plan should be set based on student's plans for the future as determined by parent and student.

If a student drops out of school before completing the four-year program, even though he may have completed the required number of units for graduation, he shall not be given a diploma until his class graduates. Exceptions may be made in these regulations for students who are ill and cannot attend school on a regular schedule, for adults wishing to take enrichment or refresher courses or wanting to complete requirements for a diploma and for other special hardship cases. All exceptions must be approved by the Board of Education. In an emergency situation, either the building principal or superintendent may make such determination.

#### ADMISSION STANDARDS FOR STATE UNIVERSITIES IN KANSAS

*Kansas Board of Regents (KBOR) Qualified Admission (QA)* standards at the regents' institutions, the standards for admission require that applicants complete the Qualified Admissions with a 2.0 GPA and by meeting one of the following requirements: (1) attain an ACT score of at least 21; or (2) attain an SAT score of at least 980; or (3) graduate in the top 1/3 of your class. The prescribed curriculum is: **English** four (4) approved units (1/2 unit may be Speech), **Math:** (Option A) 3 approved units and meet the ACT college readiness math benchmark of twenty-two (22) (Option B) four (4) approved units, one of which must be taken in the graduating year, **Social Science:** three (3) approved units, **Natural Science:** three (3) approved units, one of which must be a full unit of Chemistry or Physics, **Electives:** three (3) approved units.

*KBOR Scholars Curriculum* includes: **English:** four units, (2) **Math:** four (4) units - Algebra I, Algebra II, Geometry, and one unit of advanced mathematics – suggested courses include: Analytical Geometry, Trigonometry, Advanced Algebra, Probability and Statistics, Functions or Calculus. **Science:** three (3) units – Biology, Chemistry, and Physics, each of which include an average of one laboratory period a week, **Social Science:** One unit of US History; minimum of one-half unit of US Government and minimum of one-half unit selected from: World History, World Geography or International Relations; and one unit selected from: Psychology, Economics, US Government, US History, Current Social Issues, Sociology, Anthropology, and Race and Ethnic Group Relations, and **Foreign Language:** two (2) units of one foreign language. Latin and Sign Language are accepted.

Each institution shall establish a policy permitting not more than 10% of admissions as exceptions. The 10% exceptions shall only apply to bona fide residents of Kansas and the institution must submit an annual report of the number and percentages of freshmen admissions permitted as exception.

One unit is equal to two semesters.

Other provisions of the bill allow the admission of community college transfer students and students who receive a minimum score on the GED test. Students 21 years or older continue to be entitled to admission if they have graduated from an accredited Kansas High School.

### ATTENDANCE

Regular attendance is a responsibility that is shared by parents, students, and school. It is the student's workplace, and preparation for entry into the world of work begins with the habits and skills developed within the home, school, and community. Attendance is a very important part of developing an individual's work ethic and determining success in life.

When a student is absent from class it is impossible to recreate the situation that existed during his or her absence. Make-up work cannot take the place of having been in the classroom when the discussion was being held. Therefore, it is essential that each student be in the classroom every day possible. The maximum number of days a student can miss per semester without obtaining a doctor's excuse is ten (10). Absences beyond ten (10) days (and / or one class ten times at high school) without a doctor's excuse will be counted as unexcused for the day or missed classes (see policy on unexcused absences).

Occasionally a student's absences become excessive to the detriment of the student's success and the proper operation of the classroom. At these times a conference will be set up with the building principal, student and parent/guardian. Students who have excessive absences (over ten, per semester, not including school activities) in any class may face additional consequences by the classroom teacher and administration.

**Regular attendance is expected of all students. K.S.A. 72-3120 clearly states that parents and guardians have a legal duty to keep their child in regular attendance.**

#### PHILOSOPHY:

Pupil absence from the regular classroom learning experience disrupts the continuity of the student's instructional progress. The benefits of regular classroom instruction include class discussion, teacher presentations, and student participation. The intent of the following policy is not to punish any student, but to hold the student accountable for his/her own absences while maintaining a standard of education and providing a means whereby the conscientious student can regain some of the classroom experience missed. (Attendance Cont.)

#### POLICY:

Northern Valley Schools has established the following policies to promote the concept of regular attendance.

Regular attendance is expected of all students. Parents/guardians are responsible for excusing the absence on the day of the absence or the day the student returns. A telephone call before 9:00 AM of the day the student returns is preferred but a note when the student returns will be accepted. If parents/guardians have not contacted the school by 9:00 AM on the day the student returns, the absence will be "UNEXCUSED" and the student may receive disciplinary action.

#### *Excused and Unexcused Absences*

1. "Excused Absence" means an absence which is excused by the student's parents (or legal guardian) and by the principal. Thus, "excused" means "absent with parental permission" or "absent with a doctor's excuse beyond ten (10) days in one semester" and with principal's approval. Students have the right to make-up work.
2. The following types of absences will be considered excused:
  - a. *Illness-Frequent absences due to illness may require statement from a doctor verifying the illness.*
  - b. *Doctor or dental appointments-The school office shall be notified prior to the time of the appointment.*
  - c. *Family funerals*
  - d. *School sponsored activities*
  - e. *All other reasons are unexcused.*
3. "Unexcused Absence" means an absence which occurred without the permission and knowledge of the parents (or legal guardian) or missing more than ten (10) days in a semester without a doctor's excuse or without the permission of the principal. Unexcused absences are subject to disciplinary penalties. The principal reserves the right with good cause to declare any absence unexcused.
4. If a student becomes ill or needs to leave school grounds for personal or other reasons, a phone call must be made in the office to a parent or guardian and permission given to a school official BEFORE the student leaves. If a student leaves the building without first obtaining parent/guardian permission, and permission from a school official, the absence will be unexcused.
5. If a student needs to be dismissed from school early for an appointment, etc., the parent/guardian MUST call or send a note to the school prior to the student leaving.

6. At NO time does a student leave the building without permission from the office personnel and signing out in the office. If a student leaves the building without obtaining permission and signing out in the office, the absence will be considered unexcused.
7. If a student is tardy, he/she must obtain an admit slip from the office before being permitted to enter class.
8. When a student is absent for more than 4 hours it is considered a full day. When a student is absent for less than 4 hours, but more than an hour it will be considered a ½ day absent. Absences less than an hour will be considered Leave Early
  - a. No More than one leave early per nine weeks, when calculating Perfect Attendance

**MAKING UP MISSED WORK:**

The student is responsible for getting all missed assignments from their teachers. If a student has an excused absence on the due date of an assignment, the student must turn in the assignment on the day she/he returns to class, provided that the assignment was made prior to the absence. A student who misses class because of a school sponsored activity may be required by the instructor to complete assignments in advance of the activity. Students should understand that it may be impossible to earn a daily participation grade if not present in a class.

Two class periods are given to complete daily work missed due to each day of excused absence. For example, you are absent on Monday, you meet in class on Tuesday; the missed assignment is due on Thursday. If you are absent on Tuesday, you meet in class on Wednesday; the missed assignment is due on Friday. For extended illness, the student will be limited to five (5) school days following their return to make-up work missed. Exceptions to this rule can be made through special arrangements with the teacher or administration. No make-up credit will be allowed for un-excused absences.

Students in in-school suspension will be given one day to turn-in missed assignments for credit. Out-of-School suspensions students ARE required to make-up work but can only receive a maximum of 50% credit for this work and it must be returned the day after they return.

**TRUANCY:**

The Board of Education does not condone truancy for any reason and encourages all students to attend school on a regular and systematic basis. All children between the ages of 7 and 18 years of age are required by law to attend school “continuously” as provided by KSA 72-3120, the principal is required to report truancies to the Department of Children and Families, and to the County District Attorney within one day of being truant.

HB2109 permits law enforcement officers to temporarily detain and take into custody any child not attending school without a valid excuse during hours when school is in session. The child must be delivered to school where the child is enrolled, to any location designated by the school to address truancy issues, or to the parent or other custodian. A designated school employee must notify the child’s parent of the occurrence, either orally or in writing. A child is considered truant if he or she is required by law to attend school and such child is inexcusably absent either three consecutive days, five or more days in any semester, or seven or more days in any school year.

**TARDIES:**

Students arriving late to school must immediately report to the office, sign in, and receive an admit slip to class. If a student is detained in class, the holding teacher is obligated to give each student held a written pass for tardiness to the next class.

**DEFINITION OF A TARDY:**

1. Tardy-Students arriving to class within five (5) minutes after the bell. Students who arrive later than five (5) minutes into the class period and without a pass, or admit slip will be considered absent from class and may receive disciplinary action. Students who are dismissed during class and miss more than half of the class period will be considered absent.
2. Each teacher will develop his/her own class policy to deal with a student’s first two tardies for the semester. Any student receiving his/her third tardy within a class during the semester shall be referred to the office for administrative disciplinary action. Tardies are not accumulative from one semester to the next semester.
3. Three (3) unexcused tardies equals one absence.

**STUDENT PARTICIPATION AND ATTENDANCE AT SCHOOL ACTIVITIES**

When a student is absent from school, the student shall not participate or attend a school activity that day except in emergency situations. If a co-curricular activity falls under the jurisdiction of KSHSAA the student must be in attendance for at least the last three hours of the school day to be by 9:00 am to be eligible to participate in the activity that day or evening, unless other arrangements have been made by parents with the coach or sponsor involved.

Participants who are absent the day before a game scheduled for a non-school day shall not be eligible to participate in that activity unless the absence was due to illness or other extenuating circumstances. In such cases, approval to play must come from the Athletic

Director or Superintendent. It is the responsibility of the student sponsor, or coach to secure the approval (a note or a call from the parent(s) / guardian(s)).

#### **Attendance at Games**

A parent should accompany all children under the age of 12 to all athletic contests. Any student seen in an unauthorized area or running around the building unattended will be required to sit with their parents throughout the remainder of the contest. **If a parent is not present, the child will be sent home.**

#### **COMPUTER USE**

Students shall have no expectation of privacy when using district e-mail or computer systems. E-mail messages shall be used only for approved educational purposes. Students must use appropriate language in all messages. Students are expected to use the system following guidelines approved by teacher or the administration. Any e-mail or computer application or information in district computers or computer systems is subject to monitoring by the staff and/or administration. The school retains the right to duplicate any information created by students in a computer system or on any individual computer. Students who violate these rules or any other classroom rules relating to computer use are subject to disciplinary action up to and including suspension from school.

#### **GRADES**

One of the most important records you will have during your school years and later life will be your cumulative folders. It is permanent and will be the basis for college or for business positions. Make your record the best that you can. Ask your teacher for help. Your record starts the first time you enter the doors of Northern Valley Schools.

Report cards will be issued / mailed to parents every nine weeks following the close of the nine weeks period. Progress Reports will be sent home when students are performing below ability or failing work.

The Grading System used by Northern Valley School is based on the following percentile bands for Grades 1<sup>st</sup>-12<sup>th</sup>:

100-90% = A	69-60% = D
89-80% = B	59% and below = F
79-70% = C	

Northern Valley Junior and Senior High School will utilize a 4-point grade system. A = 4 points, B = 3 points, C = 2 points, D = 1 point and F or I = 0 points, for Failing or Incomplete.

Grades for each class will be recorded each nine weeks. A semester grade for each class will also be recorded at the end of each semester. Letter grades will be recorded on the official transcript. Letter grades and percentages will be duly recorded on all grade reports distributed to students, parents and/or guardians. All assignments are to be turned in the day they are due, grading of late assignments will be determined by individual classroom teachers.

Seniors that have met the graduation requirements set forth by the State Board of Education and the USD 212 Board of Education .... And have a cumulative GPA of 3.75 or higher, will be allowed the honor of wearing a gold cord at graduation.

#### **HONOR ROLL**

Honor roll will be announced every nine weeks following the distribution of report cards. For 6<sup>th</sup>-8<sup>th</sup> student's, grades are averaged for Math, Language Arts, Computers, Science and Social Studies. For 9<sup>th</sup>-12<sup>th</sup> student's, grades are averaged on all classes except band, vocal, Drivers Ed., and Physical Education, except for freshman physical education and health, which are required. The honor roll grade point average is for the nine weeks, and is not the cumulative average.

Honor Rolls	
Highest	4.00
Honors I	3.50 – 3.99
Honors II	3.00 – 3.49

#### **SELECTION OF VALEDICTORIAN AND SALUTATORIAN**

A Valedictorian and Salutatorian will be selected from the Senior Class each year. A grade scale of A=4 points, B= 3 points, C=2 points, D=1 point, and F= 0 points will be used for these averages. Grades for Chorus, Band, and Physical Education will not be used for these averages, except for Freshmen Physical Education and Wellness, which is required. All other grades for the four years of high school will be averaged. The student with the highest cumulative grade point average will be declared the Valedictorian. If the averages of any two students being considered for Valedictorian or Salutatorian should result in a difference of less than .01 of a point, then co-awards shall be made for Valedictorian or Salutatorian.

**CREDIT OF GRADE PLACEMENT FROM NON-ACCREDITED SCHOOLS**

Students entering the Northern Valley Schools system from non-accredited schools will be required to establish, through objective means, their grade placement in the elementary levels (K-8). Students in the elementary level will be placed in accordance with skill, competence, physical size, age, and social maturity. Competence shall be determined in conformity with established objectives as set forth in the Unified School District #212 curriculum guides for the various grade levels. Students shall be placed at a level consistent with mastery of established objectives.

High school credit will be granted only on the basis of objective testing for each unit or per-unit course. Objective testing may consist of standardized test(s) and/or teacher-made test(s), which will be administered by USD #212. Such objective testing will be consistent with established objectives as set forth in Unified School District #212 curriculum guides. No credit will be given for any course, which is normally a laboratory course involving practical application of the skills or data learned in the course unless there is clear documentation that the student having satisfactorily participated in such laboratory experiences consistent with and equivalent to the Unified School District #212 course requirements. The teacher (s), in consultation with the school administration, will evaluate the student’s performance on any objective testing, which is administered, and determine if the level of achievement is consistent with expected achievement level of students having taken such courses. Placement may also take into consideration age, physical size, and social maturity of the student.

As a practical application, the student must attain a passing grade, determined by the subject area teacher(s), before credit will be considered. The level of expectations shall be made known to the student prior to the test. The teacher (s) and administrator may determine that there are extenuating circumstances which justify an alternative achievement level, such as demonstrated accomplishments related to course objectives which justify an alternative achievement level, such as demonstrated accomplishments related to course objectives which might be allocated a differential weight for determining competence.

For the purpose of this policy, laboratory courses shall include, but not be limited to, the following:

- 1. Vocational Agriculture
- 2. Family & Consumer Science
- 3. General Shop (All Levels)
- 4. Art (All Levels)
- 5. Lab Science (Biology, Physics, Chemistry, etc.)
- 6. Band
- 7. Business Education (Keyboarding, Office Practice, Accounting, etc.)
- 8. Journalism & Yearbook
- 9. Computer Sciences
- 10. Physical Education
- 11. Vocal Music
- 12. Driver Education

In order to be eligible for consideration of any waiver of graduation requirement, a student must:

- 1. Have received their most recent ten (10) credits from an accredited high school
- 2. Have attended Northern Valley High School for two years prior to the date of graduation.

Initial grade placement or credit may be on a probationary basis subject to final evaluation for determination of final grade placement or credit. Such probation shall not exceed nine (9) weeks.

Nothing in this policy is intended to pre-judge the education of the student as acquired in any non-accredited school, but only to assure adherence to standards of Unified School District #212.

**CHANGE IN ENROLLMENT**

Changes may be made in student enrollment during the first three days of the semester. Written permission from the parents must be received before the office will change a student’s class schedule.

**FEES (BOOKS, LUNCH, BREAKFAST & OTHER)**

**BOOK RENTAL**

Grades K-8.....	\$395.00
Grades 9-12.....	\$4035.00

This covers workbook and textbook usage.

**OTHER FEES**

Vocational Agriculture.....	\$15.00
FACS.....	\$15.00
Band – all students.....	\$5.00

(5<sup>th</sup> & 6<sup>th</sup> grade band students also purchase band books)

Band Horn Rental .....	\$30.00
Percussion Rental .....	\$15.00

**LUNCHES**

Grades K-4 .....	\$3,250
Grades 5-8 .....	\$3,450
Grades 9-12 .....	\$3,550
Adults .....	\$4,600
Reduced.....	\$.40

**BREAKFAST**

Grades K-4 .....	\$2,450
Grades 5-12 .....	\$2,550
Adults .....	\$32,055
Reduced.....	\$.30

Parents are to pay in advance for lunches and/or breakfast. A monthly bill will be sent home indicating the responsibility of the payment due. If payment is not made for two consecutive months, a letter will be sent to the parent / guardian reminding them of their obligation and the possible consequences of being turned over to a collection agency. If payment of the negative balance is not received within 15 days of the third written notice, it shall be considered bad debt for the purposes of federal law concerning unpaid meal charges. The debt will be turned over to the superintendent or superintendent's designee for collection in accordance with board policy DP.

Payments for school meals may be made at the school or district office. Students, parents, and guardians of students are encouraged to prepay meal costs. Extra milk must also be purchased for 20-day periods.

The district will provide a copy of this unpaid meal charges policy to all households at or before the start of school year and to families and students that transfer into the district at the time of transfer. The terms of this policy will also be communicated to all district staff responsible for enforcing any aspect of the policy.

School lunch tickets will not be used. No cash will be accepted in the lunchroom. One carton of milk is paid for in the cost of the lunch. If extra milk is purchased for mealtime, the cost is \$0.32 per carton and does not qualify for the free / reduced program. K-4<sup>th</sup> grade may purchase extra milk if they wish in the afternoon.

Free and reduced lunch applications are available in the principal's office. **Applications should be completed and returned to the principal's office or the district office upon enrollment.**

K-4<sup>th</sup> grade may purchase extra milk if they wish in the afternoon. Extra milk is \$0.32 per carton, but does not qualify for the free reduced program.

**OFFER VERSUS SERVE PROGRAM**

U.S.D. #212 participates in the offer versus serve program. Offer versus serve is a federal regulation designed to reduce food waste in the lunch program by allowing students to choose only those foods that they intend to eat. This program is mandatory at the senior high level and is optional, by district choice, at all other levels.

In order to meet federal requirements, students must take full portions of three of the five menu components. The menu components are (1) meat or meat alternate, (2) vegetable, (3) fruit, (4) bread or bread alternate, and (5) milk.

We encourage students to take all the meal components. However, since food can only be nutritious if it is eaten, your child needs to know that components may be refused if they are not going to be eaten. Remember that all students must take at least three different meal components.

Lunches must be priced as a unit. This means paying students will pay the full lunch price and students eligible for reduced price will pay the current reduced price charge whether they take the minimum number of food items or all five food items offered.

If a child has an allergy to certain foods, a doctor's order must be submitted at the beginning of each school year.

School lunch tickets will not be used. No cash will be accepted in the lunchroom. One carton of milk is paid for in the cost of the lunch. If extra milk is purchased for mealtime the cost is \$.32 per carton. Extra milk must also be purchased for 20-day periods.

**Commented [KT1]:** These will be reviewed at the July board meeting .... So if a change is needed, please let me know. Becky and I will figure the minimum cost for breakfast, lunch, and milk.

~~Free and reduced lunch applications are available in the principal's office. Applications should be completed and returned to the principal's office or the district office upon enrollment.~~

**Commented [KT2]:** These two paragraphs are repeats from top of page.

#### **CLOSED NOON HOUR**

Northern Valley USD 212 school lunch policy is a closed noon hour, which means no one may leave school to eat lunch. Everyone eating a lunch, either school lunch or sack lunch is required to eat in the lunchroom.

If the office is notified by parent/guardian by 9:00AM (for lunch count purposes), an eligible senior (not on the ineligibility list) may leave the school campus by signing out in the office. Food or drinks obtained during lunch must stay outside the school building and are to be disposed of properly *prior* to entering the building. Students are required to be present at their next regularly schedule class period. Tardy/Absent policies will apply for any violations. Abuse of this privilege may result in revocation of said privilege.

#### **LOST AND DAMAGED BOOKS**

Students will be expected to return books checked out in their care at the end of the school term. Abusive care given to school owned books would result in students being assessed repair or replacement costs for the book. Normal wear and tear is not considered abusive care. Assessment for lost or damage books is the responsibility of the building principal.

#### **CERTIFICATE OF IMMUNIZATION**

Any pupil entering school for the first time in the state, prior to admission, shall be required to present to the appropriate school authorities certification from a licensed physician that such pupil has received or is in the process of receiving immunization against poliomyelitis, diphtheria, measles, rubella, mumps, pertussis, and tetanus, by such means of immunizations are approved by the Secretary of Health and Environment, or in the way of an alternative to such requirements shall present:

- A. Certification from a licensed physician stating the physical condition of the child to be such that the test and immunization would seriously endanger the life or health of such child, or
- B. A written statement signed by one parent or guardian that the child is an adherent of a religious denomination whose religious teachings are opposed to such test and immunization, or
- C. A written statement signed by one parent or guardian requesting that the local health department give the test and immunization because the parents or guardians lack the means to pay for such test and immunization.
- D. In accordance with the statute, the Secretary of Health and Environment has designated the following diseases for which immunizations are required of all new school enterer's: measles, mumps, rubella, polio, diphtheria, pertussis, and tetanus. Tuberculin skin testing is no longer required for school entry.
- E. The revised state requirement requires that parents of children who are not completely immunized upon school entrance shall sign a statement that the entire series of immunizations shall be completed within ninety (90) days of school entrance. Should you have any questions in this regard, please contact the building principal.

#### **VISUAL COMPETENCY**

Each year students will be tested at school to determine visual competency. This test is an indicator and may tell whether the child needs glasses. A report is sent home to the parents. The report may recommend that the child have a complete eye examination if the test given at school indicates a deficiency.

#### **ACCIDENTS AND SICKNESS**

Parents will be contacted, or in case of emergency, the child will be taken to the clinic or doctor designated by the parent, in case of accidents or sickness.

#### **COMMUNICABLE DISEASES – STUDENTS**

Any student noted by a physician or the school nurse as having a communicable disease may be required to give maximum health protection to other students. The student will be readmitted to regular classes upon termination of the illness, as authorized by the student's physician or as authorized by a health assessment team.

The board reserves the right to require a written statement from the student's physician indicating that the student is free from all symptoms of the disease.

In the event that a student is absent from regular classes for more than three consecutive days or the principal has been notified that a student has a communicable disease, the principal shall determine whether a release shall be obtained from the student's physician before the student reenters school.

Decisions regarding the type of education and the setting for provision of educational services for a student with a severe communicable disease of long duration shall be based on the behavior, neurological development, and physical condition of the student and the expected type of interaction with others in that setting. These decisions are best made using the team approach

including the student's physician, public health personnel, the student's parent or guardian, legal counsel, and personnel associated with the proposed care of educational setting.

In each case involving a student with a severe communicable disease, the board shall reserve the right to make a final decision regarding the placement of the student after taking into account the recommendation of the health assessment team, the risks and benefits to both the infected student and to the others in the proposed educational setting.

District personnel, without the student's parent' or guardian' permission or in order to comply with state or federal statutes, shall release no information regarding students with communicable diseases.

Communicable disease as defined in this policy shall refer to any infectious or contagious disease as determined by the State Department of Health and Environment or the United States Center for Disease Control.

#### **SUPERVISION OF MEDICATIONS**

The supervision of medications shall be in strict compliance with the rules and regulations of the board as carried out by district personnel. Diagnosis and treatment of illness and the prescribing of drug and medicines are not the responsibility of the public schools and are not to be practiced by any school personnel, including school nurses, unless authorized.

In certain circumstances, when medication is necessary in order that the student remain in school, the school may cooperate with the parents in the supervision of medication that the student will use. However, the medical person authorized to prescribe medication, or the parent if it is a non-prescription medication, must send a written order to the building administrator who may supervise the administration of the medication or treatment. The parent(s) must submit a written request to the building administrator requesting the school's cooperation in such supervision and releasing the school district and personnel from liability.

School personnel shall not be required to be custodians of any medication except as required by a written order of a licensed medical person or in the case of nonprescription medication when requested in writing by the parent(s).

The medication shall be examined by the school employee administering the medication to determine that it appears to be in the original container, properly handled, and to be properly authorized by the written order of a licensed medical person. Two containers, one for home and one for the school should be requested from the pharmacist. Only oral medications should be administered, except in emergency situations.

Any changes in types of drugs or dosage and/or time of administration should be accompanied by new physician and parent permission signatures with a newly labeled pharmacy container.

All medication maintained in the school setting should be kept in a locked container. This includes medications requiring refrigeration.

Medications should be inventoried every semester. Out of date stock should be returned to parent or destroyed.

Medication such as cough drops, liquid tears, antibiotic cream, or anti-itch cream may be administered as needed by the school nurse or delegated personnel. Acetaminophen and ibuprofen will be kept in the office locked medication cabinet and will only be administered when written or phone permission is obtained from a parent or guardian. Documentation of time, date and amount will be done on the treatment log.

The building administrator may choose to discontinue the administration of medication provided that the parent(s) or medical person are notified in advance of the date of the reasons for discontinuance.

After medication is administered, students should be observed for possible reactions to the medication. This observation may occur at the site of administration or in the classroom as a part of the normal routine.

This policy shall be shared with all local physicians and dentists where practicable. Forms should also be made available to the health care providers in the community.

An individual record should be kept of each medication administered. The record should include student identification, date prescribed, name of medication, time and date(s) administered, signature of person administering, and section for comments.

In the administration of medication, the school employee shall not be deemed to have assumed any legal responsibility other than acting as a duly authorized employee of the school district.

#### **Student Self-Administration of Medications**

The self-administration of medication is allowed for eligible students in grades K-12. As used in this policy, medication means a medicine for the treatment of anaphylaxis or asthma including, but not limited to, any medicine defined in current federal regulation

as an inhaled bronchodilator or auto-injectable epinephrine. Self-administration is the student's discretionary use of an approved medication for which the student has a prescription or written direction from a health care provider.

As used in this policy, health care provider means a physician licensed to practice medicine and/or surgery, an advanced registered nurse practitioner, or a licensed physician assistant who has authority to prescribe drugs under the supervision of a responsible physician.

#### ***Student Eligibility***

An eligible student shall meet all the following requirements:

1. A written statement from the student's health care provider stating the name and purpose of the medication(s).
2. The prescribed dosage.
3. The time the medication is to be regularly administered.
4. Any additional special circumstances under which the medication is to be administered.
5. The length of time for which the medication is prescribed.
6. The student shall also demonstrate to the health care provider or the provider's designee and the school nurse or the nurse's designee the skill level necessary to use the medication and any device that is necessary to administer the medication as prescribed. In the absence of a school nurse, the school shall designate a person who is trained to witness the demonstration.

#### ***Authorization Required***

The health care provider shall prepare a written treatment plan for managing the student's asthma or anaphylaxis episodes and for medication use by the student during school hours. The student's parent or guardian shall **annually** complete and submit to the school any written documentation required by the school, including the treatment plan prepared by the student's health care provider. Permission forms shall be updated during the enrollment or as needed.

#### ***Employee Immunity***

All teachers responsible for the student's supervision shall be notified that permission to carry medication and self-administer has been granted. The school district shall provide written notification to the parent or guardian of a student that the school district and its officers, employees and agents are not liable for damage, injury or death resulting directly or indirectly from the self-administration of medication.

#### ***Waiver of Liability***

The student's parent or guardian shall sign a statement acknowledging that the school district and its officers, employees and agents incur no liability for damage, injury or death resulting directly or indirectly from the self-administration of medication and agreeing to release, indemnify and hold the schools and its officers, employees, and agents harmless from and against any claims relating to the self-administration of medication allowed by this policy.

The parent or guardian of the student shall sign a statement acknowledging that the school incurs no liability for any injury resulting from the self-administration of medication and agreeing to indemnify and hold the school and its employees and agents harmless against any claims relating to the self-administration.

#### ***Additional Requirements***

1. The school district shall require that any backup medication provided by the student's parent or guardian be kept at the student's school in a location to which the student has immediate access if there is an asthma or anaphylaxis emergency.
2. The school district shall require that all necessary and pertinent information be kept on file at the student's school in a location easily accessible if there is an asthma or anaphylaxis emergency.
3. Eligible students shall be allowed to possess and use approved medication at any place where the student is subject to the jurisdiction or supervision of the school district and its officers, employees or agents.
4. The board may adopt policy or handbook language which imposes additional requirements relating to the self-administration of medication allowed for in this policy. The board may establish a procedure for, and the conditions under which, the authorization for student self-administration of medication may be revoked.

#### **ANIMALS AND PLANTS IN THE SCHOOL**

Any person bringing animals and toxic plants into the school must receive prior permission from the supervising teacher and the building principal. All animals must have an up-to-date (less than 1 year old) health certificate before any animal is permitted on school grounds.

#### **WEAPONS**

Possession, use, or transfer of any illegal weapon by students inside the school building, on school property, or at school sponsored activities, inside the district or out of town, is expressly prohibited. This policy shall include any weapon, any

item used as a weapon or destructive device, or any facsimile of a weapon. This policy is in effect before school, during the regular school day, after school or at any school sponsored activity.

Illegal weapons would include firearms, replica firearms, starter guns, air propulsion rifles or pistols, BB guns or any other type of destructive device or apparatus that could be used to propel projectiles that could cause injury to others. This policy would also include switchblade knives, gravity operated knives, knives with blades in excess of 1.5 inches, knives containing pocket or belt clips, martial arts weapons including "butterfly knives", clubs or other bludgeoning instruments, metal or brass knuckles, stun guns, bombs, explosives, grenades, rockets, missiles, or other destructive devices including incendiary devices or poisonous gases. Violation of this policy will result in immediate and appropriate disciplinary action and referral to the appropriate legal authorities.

Possession of a firearm or other illegal weapon shall result in expulsion from school for a period of one year except that the superintendent may recommend that this expulsion requirement be modified on a case-by-case basis (Probation). Students violating this policy shall be suspended and/or expelled and referred to the appropriate law enforcement agency (agencies).

As used in this policy, the term "firearm" means any weapon (including a starter gun) which will, is designed to, or may readily be converted to expel a projectile by the action of an explosive, the frame or receiver of any such weapon, any firearm muffler or silencer, or any destructive device.

As used in this policy, the term "destructive device" means any explosive, incendiary, or poison gas; bomb, grenade, rocket having a propellant charge of more than four ounces, missile having an explosive or incendiary charge of more than one-quarter ounce, mine, or other device similar to any of these devices.

Any student who brings a weapon to school will be referred to the criminal justice or juvenile delinquency system.

#### **BULLETINS FROM SCHOOL**

From time to time during the year, it becomes necessary for the teacher or administrator to send bulletins to the parents explaining some phase of the school program. These bulletins are important and an effort will be made to keep them at a minimum. Parents are urged to read all notes sent home so misunderstandings of the school program may be kept to a minimum. It is hoped that this handbook will suffice for many announcements that might otherwise have required a special bulletin.

#### **FIRE DRILLS**

When the fire alarm sounds, the building should be evacuated immediately. Do not take books or any other supplies with you on a fire drill. Each class should form one single line. NO running, talking, or crowding in line. Students should quietly return to class upon signal.

#### **TORNADO DRILLS**

The intermittent ringing of the classroom bells will signal tornado drills. You are to form a single line and proceed quickly and quietly to the basement hallway. It is important that you be quiet, so that you may hear any instructions that may be given.

You may return quietly to the classroom only when the Superintendent, the Principal has released the entire student body, or in their absence, a designated teacher.

#### **FIRE AND TORNADO EVACUATION FOR HANDICAPPED STUDENTS**

The primary person responsible for helping handicapped students evacuate the building is the teacher that has the student in class. The secondary person responsible to help the student is the janitor of the building involved.

#### **PARTIES**

It shall be the policy of the school that parties, dances and other social events shall be held on school premises and using school facilities. All school parties are for students of the school only. Board Policy states that there is no more than one dance per month during the school year.

The school will allow party invitations to be handed out at school only if the following conditions are met. If the party is for either a boy or a girl, then all girls or all boys of the class shall be invited. If both boys and girls are being invited, then all members of the class shall be invited. Student birthday parties will be allowed with the classroom teacher approval. K-4<sup>th</sup> grade students will not be allowed to exchange gifts at school.

High School students in our school may bring outside dates to some school dances if their sponsor obtains permission from the Board of Education. High School students will need to sign up their intended date and get approval from the office. The office will notify you of the dances at which outside dates may be brought.

### HAZING/BULLYING

The board is committed to providing a positive and productive learning and working environment. Hazing, harassment, intimidation, menacing or bullying by students, staff, or third parties is strictly prohibited and shall not be tolerated in the district. Students whose behavior is found to be in violation of this policy will be subject to discipline, up to and including expulsion. Staff whose behavior is found to be in violation of this policy will be subject to discipline, up to and including dismissal. Third parties whose behavior is found to be in violation of this policy shall be subject to appropriate sanctions as determined and imposed by the superintendent or board. Individual may also be referred to law enforcement officials.

Bullying is defined as any non-instigated, unprovoked, and intentional gesture; written, verbal, or electronic communication; physical act; or threat that a reasonable person would find severe or pervasive that it creates an intimidating, threatening, or abusive educational environment for a student or staff member.

### SCHOOL BUS PASSENGER CONDUCT

Buses are furnished at a great expense to USD 212. Because of this, it is our belief that the students, drivers and sponsors should work together to maintain the buses for the benefit of all.

All students, drivers, sponsors and patrons who ride the Northern Valley District buses whether on regular routes or on activity trips will adhere to the following regulations.

1. The bus driver shall be in charge of all passengers while they are riding, loading on or unloading from the bus.
2. The bus driver shall have the authority to assign a seat to each passenger.
3. Students shall not stand in the traveled portion of a roadway while waiting for a bus.
4. Students shall not extend any part of their body out of bus windows.
5. Students shall not get on or off the bus or move about while the bus is in motion
6. Smoking inside a bus shall be prohibited. All tobacco products will be prohibited.
7. Intoxicating liquor or alcohol, or illegal drugs shall not be consumed or carried on the bus.
8. Animals shall not be transported in a bus.
9. No weapons of any type, except side arms carried by a law enforcement officer shall be transported on a bus. (Authorized by K.S.A. 1977 Supp. 8-2009; effective E-78-22, Aug. 10, 1977; effective May 1, 1978.)
10. No sunflower seeds on the bus.
11. Bottles or cans of pop on the bus by permission only.
12. Keep noise at a normal conversation level.
13. No iPods or MP3 players will be played on the bus, unless individual earphones are utilized. No exceptions will be made. One warning will be given, and then the device will be taken from the offender by the sponsor or driver and given to the principal.
14. Cell phones may be used with the permission from the bus monitor, coach/sponsor, or bus driver. No FLASH pictures using your cell phone or camera is permitted at any time.
15. All passengers should unload from the front of the bus.
16. Students will pick up trash and belongings before leaving the bus. The sponsor and/or driver will determine how this is to be done. If the buses are found to be in an unacceptable condition, the building administrator will make cleaning assignments, as he/she deems necessary.
17. PUPILS MUST BE ON TIME; THE BUS CANNOT WAIT FOR THOSE WHO ARE TARDY. Pupils must walk on the far-left side of the road facing traffic when going to the bus stop.
18. Unnecessary conversation with the driver is prohibited. Do not talk loud or distract the driver's attention. Remember that your safety is in his hands.
19. Pupils must not throw waste paper or other rubbish on the floor of the bus. Help keep your bus clean and sanitary at all times.
20. When leaving the bus, pupils must observe directions of the driver. IF YOU CROSS THE ROAD, DO SO IN FRONT OF THE BUS AFTER MAKING SURE THE ROADWAY IS CLEAR.
21. Any damage to the bus is to be reported to the driver at once.
22. All students must ride the activity bus to and from the activity, unless the parents come to the sponsor or administrator at the activity and sign out their child to go home. Notes will not be accepted.
23. Sponsor should make last check of bus for articles left on the bus.
24. In an emergency when students cannot ride an activity bus, failure to notify the sponsor may prevent them from riding in the future.
25. TO FACILITATE THE ENFORCMENT OF THE ABOVE RULES, THE SPONSORS WILL RIDE AT OR NEAR THE BACK OF THE BUS.

26. STUDENTS RIDING A BUS DURING A STORMY SEASON ARE ADVISED TO LISTEN TO THEIR HOME RADIO OR TV STATION FOR STORM WARNINGS AND NOTICE OF SCHOOL CLOSINGS AND NOT ATTEMPT TO REACH SCHOOL WHEN SO FOREWARNED. (AS TO UNSAFE CONDITIONS SUCH AS HEAVY SNOW OR FLOODS.)
27. As July 1, 1989, The Child Passenger Safety Act requires that every driver who transports a child or children under the age of 14 years to provide for the protection of the child or children by using the proper safety restraining system. The proper restraining system of children between the ages of 4 to 14 is a safety belt and applies to both front and rear seats of a vehicle. For preschool under the age of 4, the requirement remains the same as in the old law. This law applies to anyone riding in vans, automobiles, pickup trucks, suburban's, etc.

PENALTY: For violating these rules, pupils will be reported to the school principal who can deny pupils the privilege of riding the bus.

#### **TRAFFIC RULES AND REGULATIONS**

All students who drive cars to school will park in areas designated for student parking. They will also park in a manner which will not block other cars or park on the grass.

If it is necessary for you to go to your car during school hours, permission must be secured from the OFFICE. Students are not to be in or about their cars during school hours. Students who drive are asked to use extreme caution when driving in front of the elementary school. Students failing to follow posted speed limits or are driving in a careless manner will receive a warning from the administration. On the second offense the student will be reported to the authorities. On the third offense, the student will be reported to the authorities and 5 points will be given.

#### **STUDENT CONDUCT (Kindergarten – 5<sup>th</sup> Grade)**

1. A student shall be corrected when necessary to improve the student's behavior, to maintain essential order, or to protect other students, school employees, or property.
2. Students shall be treated fairly and equitably. Discipline shall be based on a careful assessment of the circumstances of each case. Factors to consider shall include:
  - a. The seriousness of the offense
  - b. The student's age
  - c. The frequency of misconduct
  - d. The student's attitude
  - e. The potential effect of the misconduct on the school environment
3. Guidelines for discipline apply to all school sponsored activities as well as the school day. Students, when in attendance at any athletic event, contest, dance, school programs, or other activity sponsored by the school, will be required to obey all rules and regulations which govern the regular school day.
4. Students who cause major code infractions will receive out of school suspensions. The suspension from school can be from one to ten days depending upon the code infraction. When a student is suspended they cannot take part in any school function or activity. This also means that they cannot be on school grounds during the duration of the suspension. Students' parents will be notified by phone and also by mail if a suspension is assigned. A parent conference is required before the student will be admitted back to school after serving the assigned suspension.
5. A student may be suspended or expelled, for reasons set forth in Kansas law, by the following certified personnel: superintendent or principal. Any student who is suspended or expelled shall receive a copy of the current suspension and expulsion law and this policy. Expulsion hearings shall be conducted by the superintendent or other certified employee or committee of certified employees of the school in which the pupil is enrolled or a hearing officer appointed by the board, or another person appointed by the board.
6. Electronic Devices and Cell Phones have no place in the classroom during school hours. They are to be silenced during the school day. Exceptions will be determined by the classroom teacher. 1<sup>st</sup> Offense – Staff member turns cell phone into office and student may pick up after serving 30 minute detention. 2<sup>nd</sup> Offense – Staff member turns cell phone into office and student may pick up after serving 60 minute detention & parent/guardian is notified. 3<sup>rd</sup> Offense – Staff member turns cell phone into office and will result in 1 Day of In School Suspension & parent/guardian in notified. Further Violations will result in doubling of ISS days and parent/guardian notification.

**Level I Acts of Misconduct  
May Include, but not limited to**

**Possible Discipline Options/Responses  
May Include, but not limited to**

- Noncompliant Behavior
- Violation of Classroom Rules
- Misbehavior
- Act that disrupts the classroom
- Disrespectful Behavior
- Failure to be Honest
- Verbal Correction
- In class disciplinary action
- Teacher-student conference
- Parent contact: note/email/phone call

**Level II Acts of Misconduct**

**May Include, but not limited to**

- Repeated infractions
- Cheating or Plagiarism
- Inappropriate Language: Verbal or Written
- Unapproved use of electronic devices
- Bus Conduct Notice
- Fighting
- Destruction of Property
- Stealing
- Conduct that impinges on the safety of others
- Skipping Class
- Computer Violation

**Possible Discipline Options/Responses**

**May Include, but not limited to**

- Detention
- Principal-student conference
- Parent Contact: note/email/phone call
- Office Referral
- Missed Recess

**Level III Acts of Misconduct**

**May Include, but not limited to**

- Repeated infractions
- Terrorist Threats
- Bullying
- Possession of Illegal Weapon

**Possible Discipline Options/Responses**

**May Include, but not limited to**

- Principal-Parent conference
- Involvement of Support Services
- Exclusion from extracurricular activities or trips
- Implementation of a Behavior Plan

**Level IV Acts of Misconduct**

**May Include, but not limited to**

- Repeated infractions
- Use of tobacco products on school property
- Use of alcoholic beverages on school property
- Use of illegal drugs on school property

**Possible Discipline Options/Responses**

**May Include, but not limited to**

- In School Suspension
- Out of School Suspension

\*All disciplinary guidelines are subject to administrative discretion.

**STUDENT CONDUCT (6<sup>th</sup>-12<sup>th</sup> Grade)**

1. Repeated instances of almost any offense will result in suspension or expulsion. Also, if multiple violations are contained on a disciplinary referral, the totality of the offenses will be considered when implementing disciplinary action.
2. Terrorist threats which would include bomb threats, false fire alarms, death threats, or threats to inflict bodily harm will result in suspension or expulsion.
3. The consumption, possession, use, transfer, or to be under the influence of any narcotic, controlled substance, or illegal drug anywhere on school property or at any school sponsored activity, whether within the school district or out of town, is expressly prohibited and will result in suspension or expulsion and referral to the appropriate legal authorities.
4. Possession, use, or transfer of any weapon by students inside the school building, on school property, or at school sponsored activities, inside the district or out of town, is expressly prohibited. Illegal weapons would include firearms, replica firearms, starter guns, air propulsion rifles or pistols, BB guns or any other type of apparatus that could be used to propel projectiles that could cause injury to others. This policy would also include pocket knives, switchblade knives, gravity operated knives, knives with blades in excess of 1.5 inches, knives containing pocket or belt clips, martial arts weapons including "butterfly knives", clubs or other bludgeoning instruments, metal or brass knuckles, stun guns, bombs, explosives, grenades, rockets, missiles, or other destructive devices including incendiary devices or poisonous gases. Violation of this policy will result in immediate and appropriate disciplinary action and referral to the appropriate legal authorities. This policy is in effect before school, during the regular school day, after school or at any school sponsored activity. Possession of a firearm shall result in expulsion from school for a period of one year. Students violating this policy shall be suspended and/or expelled and referred to the appropriate law enforcement agency (agencies).

5. The mischievous or malicious setting of fires or other acts of arson inside of any school building or on any school property will result in suspension or expulsion and referral to the appropriate legal authorities.
6. Conduct which endangers the safety or substantially impinges on or invades the rights of others- will result in suspension or expulsion and referral to the appropriate legal authorities.
7. Theft-misdemeanor or felony-will result in suspension or expulsion and referral to the appropriate legal authorities.
8. Vandalism- misdemeanor or felony-will result in suspension or expulsion and referral to the appropriate legal authorities.
9. Inappropriate behavior towards any administrator, instructor, staff member, or school guest will result in suspension or expulsion. Repeated instances of open defiance or refusal to obey any reasonable request, inappropriate remarks or comments and acts of disrespect will result in suspension or expulsion. Repeated disrespect in a class may require a parent, student, teacher, and administrator conference which would require a behavior contract before the student can re-enter the class.
10. Instances of harassment, intimidation, threats, and extortion could result in suspension or expulsion.
11. Any involvement in gang or gang related activities such as wearing of gang apparel, exhibition of gang signs or symbolism, graffiti, (including cult or satanic symbolism) at school property will result in suspension or expulsion.
12. Students will not be allowed to make any inappropriate remarks or exhibit any behavior that demeans, ridicules, or "puts down" any race, religion, creed, sex, national origin, or handicapping condition. Any student or group of students who possess, attempt to distribute, or distribute any unauthorized material at school or on school property which is racially derogatory, divisive, inflammatory, supremacist oriented, or who vandalize or deface school property with racially derogatory, inflammatory, or divisive graffiti, slogans, or symbols will be suspended or expelled.
13. Sexual harassment is defined as a practice which undermines the learning process of a school by creating an environment which is upsetting, threatening, or degrading to the student being harassed. Examples of sexual harassment would be, but are not limited to the following, uninvited or unwelcome notes, letters, telephone calls, or other materials of a sexual nature. It could also involve uninvited and deliberate touching, groping, leaning on or over, or cornering, uninvited sexually suggestive looks, gestures, pressure for sexual favors, persistent pressure for dates and other intimate situations. Sexual harassment could also involve sexual teasing, making of suggestive remarks, asking improper questions or telling jokes that are off color explicitly related to sex. Sexual harassment could also include attempted or actual rape or sexual assault or the visual display of materials that may be perceived as offensive to either male or female, i.e., posters, calendars, photographs, graffiti or signs. Violations of this regulation will result in suspension or expulsion.
14. Boy and girl relationships are a normal part of growing and maturing. In the school, however, there is to be no public display of affection. Parents/guardians will be contacted for those who cannot refrain from improper displays. Repeated violations of this regulation will result in detention and/or suspension.
15. When a substitute teacher has taken the place of a regularly assigned teacher, the expectation is, students will be on their "best" behavior. Any student referred to the office for disciplinary reasons can expect consequences resulting in detention(s) and/or suspension.
16. Electronic Devices and Cell Phones are to be silenced during the school day and not to be used during class time. Exceptions will be determined by the classroom teacher. 1<sup>st</sup> Offense – Staff member turns cell phone into office and student may pick up after serving 30 minute detention. 2<sup>nd</sup> Offense – Staff member turns cell phone into office and student may pick up after serving 60 minute detention & parent/guardian is notified. 3<sup>rd</sup> Offense – Staff member turns cell phone into office and will result in 1 Day of In School Suspension & parent/guardian in notified. Further Violations will result in doubling of ISS days and parent/guardian notification.
17. Cell phones, cameras, and/or video recorders are NOT permitted to be used in ANY LOCKER ROOM AT ANY TIME including before and after school or any school sponsored events.
18. NO BULLYING: bullying is defined as any non-instigated, unprovoked, and intentional gesture; written, verbal, or electronic communication; physical act; or threat that a reasonable person would find severe or pervasive that it creates an intimidating, threatening, or abusive educational environment for a student or staff member.
19. Food or drinks obtained during lunch must stay outside the school building and are to be disposed of properly prior to entering the building.

\*All disciplinary guidelines are subject to administrative discretion.

The below guidelines for discipline apply to all school sponsored activities as well as the school day. School activities are an extension of the school day. Students, when in attendance at any athletic event, contest, dance, school programs, or other activity sponsored by the school, will be required to obey all rules and regulations which govern the regular school day. Students assigned to OSS will not be allowed to participate in school activities. Whenever discipline is assigned, parents/guardians are notified through the mail or by phone.

*Consequences for Conduct Violation:*

A point system, which outlines the consequences of individual and accumulative behavior, appears below. The following are the descriptions of the offenses, the points assigned to each party, and the penalties.

<b>Offense</b>	<b>Points</b>	<b>Penalty</b>
Weapons Violation	13	Long Term Suspension/Expulsion
Arson	13	Long Term Suspension/Expulsion
Terroristic Threat	13	Long Term Suspension/Expulsion
Conduct which impinges on the safety of others	13	Long Term Suspension/Expulsion
Alcohol or Drugs	5	1-10 Day Suspension
Fighting/Use of Physical Force	2-5	1-10 Day Suspension
Tobacco	5	1-10 Day Suspension
Theft	2-5	1-10 Day Suspension
Disrespect & Insubordination	2-5	Detention/Suspension
Destruction of Property	2-5	Detention/Suspension
Bullying or Harassment	2-5	Detention/Suspension
Cheating or Plagiarism	1-5	Detention/Suspension & Zero on Assignment
Disruptive Behavior	1-2	Detention 1 to 6 Hours
Skiping Class or School	1-2	Detention 1 to 6 Hours
Inappropriate Language	1-2	Detention 1 to 6 Hours
Skiping After School	0-2	Detention 1 to 6 Hours
Bus Referral	0-1	3 Points = loss of bus privilege
PDA	0-1	And/or 1 to 4 Hours of Detention
Repeatedly Unprepared for Class	0-1	And/or 1 to 4 Hours of Detention
Food/Drink Violation	0-1	And/or 1 to 4 Hours of Detention
Every 3 <sup>rd</sup> Tardy	0-1	And/or 1 to 4 Hours of Detention
Computer Network	0-1	And/or 1 to 4 Hours of Detention
Lying	0-1	And/or 1 to 4 Hours of Detention
Miscellaneous Violation	0-1	And/or 1 to 4 Hours of Detention
Unexcused Absences All Day (1 <sup>st</sup> Offense)	0	2 Hours Detention
Unexcused Absences All Day (2 <sup>nd</sup> Offense)	1	4 to 6 Hours Detention
Unexcused Absences All Day (3 <sup>rd</sup> Offense)	2	2 Days ISS
Unexcused Absences All Day (4 <sup>th</sup> Offense)	3	5 Days ISS
Unexcused Absences From Class or Activity (1 <sup>st</sup> Offense)	0	Time Missed During Detention
Unexcused Absences From Class or Activity (2 <sup>nd</sup> Offense)	1	Double Time Missed During Detention
Unexcused Absences From Class or Activity (3 <sup>rd</sup> Offense)	2	1 Days ISS
Unexcused Absences From Class or Activity (4 <sup>th</sup> Offense)	3	3 Days ISS

Any other violation that interferes with the delivery of a safe and quality education will be dealt with in a manner fitting the offense as determined by the school administration. A severe offense can result in the student failing the class and his/her removal from the class until the next semester it is offered.

If a student accumulates 6 points he/she will be given in-school suspension for 2 days. If a student accumulates 10 points, he/she will be given in-school suspension for 5 days. If a student accumulates 13+ points, he/she will be suspended (ISS or OSS) for 10 days and may be recommended for a long term suspension or expulsion (determination will be made based on the severity of the offense[s]).

Parents or guardians will be notified by mail and/or phone when their child reaches 3 points and 6 points. Parents or guardians will be notified by mail when their child reaches 9 points and a conference will be scheduled.

A copy will be signed by student and kept on file with the principal.

#### *GUIDELINES FOR DETENTION ASSIGNED BY THE ADMINISTRATION*

Administrative assigned detention will convene promptly by ~~4:00~~ **3:30** PM in Long Island ~~and 3:45 PM in~~ **Almena** and will last up to 120 minutes. Students will be given the choice of attending detention the day they were seen by the administrator or the following day. Students may be assigned classroom work to be completed and returned to the instructor. Credit will be given and all assignments must be completed. Other obligations, including work, will not be cause for dismissal from detention. Exceptions to this policy will be handled on a limited and individual basis. Parents requesting that a detention be postponed must make the request to a building administrator prior to the date the detention is to be served. Failure to serve detention will result in further sanctions.

#### *SUSPENSION*

Students who cause major code infractions will receive out of school suspensions. The suspension from school can be from one to ten days depending upon the code infraction. When a student is suspended they cannot take part in any school function or activity. This also means that they cannot be on school grounds during the duration of the suspension. Students' parents will be notified by phone and also by mail if a suspension is assigned. A parent conference is required before the student will be admitted back to school after serving the assigned suspension.

#### **EXPULSION**

A student may be suspended or expelled, for reasons set forth in Kansas law, by the following certified personnel: superintendent or principal. Any student who is suspended or expelled shall receive a copy of the current suspension and expulsion law and this policy. Expulsion hearings shall be conducted by the superintendent or other certified employee or committee of certified employees of the school in which the pupil is enrolled or a hearing officer appointed by the board, or another person appointed by the board.

#### **SCHOOL TELEPHONE**

The school telephone is a business phone; it should not be used for social calls. Students are not to use the phone except in unusual circumstances (**leaving homework at home is not an unusual circumstance**). If the case should arise, the student should check through the office before using the phone. Students will not be called from class to answer the telephone, but messages will be taken and given to the student at the end of the period.

THE SPONSOR MUST UNLOCK THE DOOR FOR STUDENTS WHO NEED TO CALL THEIR PARENTS TO COME AND GET THEM AFTER AN ACTIVITY. THE SPONSOR SHALL STAY WITH THE STUDENTS UNTIL ALL HAVE BEEN PICKED UP AND THEN LOCK THE DOORS.

#### **LOCKERS**

Lockers are for the convenience of the students. They should not be mistreated. The doors should be closed quietly. Please do not decorate the outside of your lockers. The inside may be used for decoration if you think it is necessary, but must be cleaned out at the end of the year.

ALL lockers may be checked periodically for books and magazines that belong to the library but have not been properly checked out.

#### **SEARCHES OF LOCKERS AND STUDENTS**

ALL lockers are the property of USD #212 and are subject to inspection by school authorities at any time and will be done periodically.

Searches of students shall be conducted when reasonable suspicion exists that a school rule or policy has been violated. In order to protect the health, safety, and welfare of students under school jurisdiction, building principals are authorized to search students. All searches shall be carried out in the presence of an adult witness.

Only the school principal or his designee is authorized to conduct searches of lockers or students. Prohibited items recovered during a search shall remain in the custody of the building principal or turned over to law enforcement officials, illegal incidents will be referred to the appropriate law enforcement agency.

#### **DRESS CODE**

Hats or other headgear will not be worn inside buildings before or during school hours. This rule also includes those times when Northern Valley students are located in other facilities for any reason. Special circumstances stated by the administrator only can alter this rule. Other clothing deemed inappropriate shall not be worn at school including, but not limited to, clothing with alcohol, tobacco, drugs or sex or sexual innuendo displayed, low cut tops or tops that do not have a two inch strap across the shoulder, no tank tops, and no tops with the sides ripped out. No undergarments should be showing. No midriff should be showing. Skirts and shorts shall be as long as the longest fingertip when hands are hanging normally at sides.

#### **GUESTS**

Visitors will be allowed to visit school if arrangements are made with the office at least one day in advance. Visiting youngsters will not be allowed to visit school on a day-to-day basis, as the teachers are not employed as babysitters. The school welcomes visits by parents at any time. During the school year all parents are encouraged to attend the activities sponsored by the school.

#### **POSTING OF MATERIALS ON SCHOOL PREMISES**

Nothing is to be posted in the school building (bulletin boards) or on school grounds unless approval has been given by the building principal.

## **PUBLIC DISPLAY OF AFFECTION**

There will be **NO** public display of affection (PDA) including but not limited to holding hands, hugging, kissing, etc.

## **PLAGIARISM**

Academic dishonesty is not acceptable. Cheating, defined as copying another student's work and claiming it as your own and plagiarism, defined as the use of another person's original ideas or writing without giving credit to the true author, are both prohibited practices. Materials taken from electronic sources are covered by this policy.

A student who engages in any form of academic dishonesty will be subject to the loss of credit for the work in question, as well other disciplinary measures up to and including suspension or expulsion.

## **SPORTS AND ACTIVITIES ELIGIBILITY**

The board encourages the development of co-curricular activities compatible with these policies.

Any student who does not wish to participate in any required, school-sponsored activity must file a written statement with the superintendent requesting that the student not be required to participate in the activity. The written statement must be signed by one of the student's parents and explain the reason(s) why the student should be exempt from participating in the activity.

6-12 students who wish to participate in any school sponsored activity (on or off campus) other than attending regularly scheduled classes during the normal school day and participating in practices, must have passed at least five units of credit the preceding semester. Students failing two (2) or more subjects in one week or failing one (1) class two or more weeks in a row will be considered ineligible. Eligibility is determined utilizing the student's eligibility for the first week in the second semester. Thereafter, the cumulative class grades earned each week in the second semester will apply. Each instructor will list by name and subject any student who is receiving a failing grade and have his/her list to the building administrator and building secretary by Monday morning. The "Failing List" will be compiled and emailed to all staff members.

The Kansas State High School Activities Association and the local school determine athletic eligibility. All students interested in the interscholastic athletic program should acquaint themselves with the many regulations and determine eligibility. The athletic coaches can answer your questions and there is a copy of the K.S.H.S.A.A. rules containing all the printed regulations in the office.

A student, as an individual involved in an activity offered at our school, is recognized as an OFFICIAL REPRESENTATIVE of the school and its community. Your conduct and sportsmanship on and off the school premises should display the highest possible standards. **BE PROUD TO BE A HUSKY AND MAKE OTHERS PROUD!**

## **LEAGUE**

Northern Valley High School and Junior High is a member of the Western Kansas Liberty League. League championships are awarded in football, basketball, volleyball, and track. The league sponsors speech contests, vocal and instrumental festivals and concerts, and academic competitions.

## **ACADEMIC LETTERS**

9<sup>th</sup>-12<sup>th</sup> Students may letter academically by making a 3.3 GPA or above for the last semester of previous year and the first semester periods of each school year and having no grade below a B (no C, D, or F grades). Classes which will not be included in the GPA for Academic lettering are; Band, Vocal, PE (Except for Freshmen PE/Wellness), and Teacher Aide. Freshmen letters will be used on the first semester of the school year.

## **PHYSICAL FORMS**

Before a student athlete is permitted to report for practice in a sport, he/she must have a physical examination or health review documented by a completed form furnished by the school. Either form requires the student to gain the permission of his or her parents or guardian. **THE FORM REQUIRES THE SIGNATURES OF BOTH THE PARENT AND THE ATHLETE.**

## **TRAVELING TO AND FROM ACTIVITIES**

In order to promote team building and camaraderie the squad and/or team members are expected to ride to and from games in the bus, or whatever means of transportation is provided by the district. However, a squad member must secure the approval of the administrator by filling out a transportation waiver before any contest to ride home with an adult other than the student's parent/guardian. **PARENT /GUARDIAN PHONE CALL AUTHORIZATIONS WILL NOT BE ACCEPTED.** Transportation waiver must be signed by the parent/guardian and contact information must be provided to verify signatures.

#### ***AGE RULE***

Any student, who reaches the age of nineteen (19) on or before September 1, shall be ineligible for participation in any interscholastic activity. Any student, who reaches the age of nineteen (19) after September 1, shall be eligible for the balance of the school year.

#### **ALCOHOL TESTING AT SCHOOL ACTIVITIES**

Students or student guests attending a school sponsored activity that are deemed (by reasonable suspicion) to be under the influence of alcohol are subject to alcohol testing. Anyone refusing to be tested or testing positive will have their parents and the authorities notified. Students will be transported by parents or authorities from school premises. Student guest who test positive or refuse to be tested will be permanently banned from future school activities. Students who test positive or refuse to be tested will be subject to the school discipline and athletic policies.

#### ***INSURANCE***

The school does have accident insurance; however, all expenses incurred must first be submitted to the parent/guardian's insurance company for payment. Expenses not covered by the parent/guardian's insurance can then be referred to the insurance carrier of the school district (Student Assurance Services, Inc.). Expenses not covered by either will become the final responsibility of the parent/guardian. Accidents or injury must be reported in a timely manner. The school insurance will not cover expenses for injuries, which occur as a result of horseplay or fighting.

#### ***INDIVIDUAL ENTRY FEES***

Any activity that requires an INDIVIDUAL entry fee must be attended by the student who committed to attend the event. Students failing to attend once the entry fee has been paid will be required to reimburse the school for the loss of the entry fee and may be prevented from competing in additional competitions until this is paid. Exceptions to this rule may be made on an individual basis for limited reasons.

#### **ACTIVITY FUND**

The activity fund is the financial headquarters for all the extracurricular funds. All high school organizations that have funds in their treasuries are required to deposit their money in this fund. The school secretary is the bonded treasurer and the custodian of these accounts that are subject to audit annually. **Purchases are to be made only with a purchase order issued by the office.** The purchase order is presented to the supplier and is thus authorized to charge the items listed to the organization. Bills are then brought into the office, but should be recorded as expenditures by the treasurer of the class or organization. Class treasurers should check their books with the office secretary each month.

#### **REMOVED SPECTATOR POLICY**

Sportsmanship, while important for the participants of a sporting activity, is also of the highest importance for the spectator as well. Accordingly, there should be no room for a spectator to repeatedly get removed from athletic contests by the officials or administration. The center of attention during an athletic event should be on the game and its participants, not a spectator that insists on making a scene because they disagree with an official's call or a coach's decision.

Accordingly, effective starting the 2019 – 20 school year, the following consequences will be issued for spectators (adult or student; including employees of Northern Valley USD 212) that are removed from athletic contests:

**First Offense-** The removed spectator will be banned from attending ANY athletic contests in which Northern Valley HS or JH is a participant, for a period of **14** days (beginning with the date of removal). Should the season end before the 14 day period ends, the consequence will be carried over into the next sports season (i.e. Fall to Winter), *with the count resuming on the day of the first scheduled athletic contest of that season.*

**Second Offense-** The removed spectator will be banned from attending ANY athletic contests in which Northern Valley HS or JH is a participant, for a period of **45** days (beginning with the date of removal). Should the season end before the 45 day period ends, the consequence will be carried over into the next sports season (i.e. Fall to Winter), *with the count resuming on the day of the first scheduled athletic contest of that season.*

**Third and Subsequent Offenses-** The removed spectator will be banned from attending ANY athletic contest in which Northern Valley HS or JH is a participant for a period of **one calendar year** (beginning with the date of removal).

Exceptions will **not** be made for special events (i.e. Senior Night).

Attempts to enter a contest from which the spectator is banned will be viewed as trespassing, and law enforcement will be called should the banned spectator refuse to leave the premises. The banned spectator will also be immediately subjected to the next punishment in the sequence (i.e. should a spectator that is banned for 14 days attempt to enter an athletic contest during that 14-day period, that spectator will now be banned for 45 days, starting from the date of the second infraction).

#### **NORTHERN VALLEY CHAPTER OF THE NATIONAL HONOR SOCIETY BYLAWS**

The Northern Valley Chapter of the National Honor Society is open to juniors and seniors who meet the qualifications established by the National NHS Constitution, and the guidelines for eligibility set by the Northern Valley NHS Faculty Council. Membership is an honor bestowed upon a select group of students by the faculty council on behalf of the school faculty. Membership is based on four criteria: Scholarship, Character, Service, and Leadership. All chapters are governed by the National NHS Constitution. Local needs and conditions are addressed through the chapter bylaws. An induction ceremony is held in the spring.

##### *NORTHERN VALLEY NHS ELIGIBILITY REQUIREMENTS:*

- Students may be selected after the first semester of their junior year and must have a 3.5 cumulative GPA or better.
- Students must have been in attendance at Northern Valley the equivalent of one semester. The semester guidelines may be waived for a student who has transferred to the school, after seeking and receiving a recommendation from the student's previous principal.
- Once identified, eligible candidates will receive an invitation to join National Honor Society. The invitation will include an Interest Survey. Candidates will have at least one week to complete the survey and return it to the Chapter Advisor.

##### *SELECTION AND EVALUATION PROCESS:*

- Once the interest survey is received, the chapter advisor may gather information on all applicants.
- In addition to the survey, information may be gathered from (but not limited to): teacher, administration, club sponsors, coaches, parents, employers, and student records.
- All information received will be confidential and maintained by the Chapter.

##### *MEMBERSHIP:*

- Active members must maintain the standards by which they were selected-Character, Leadership, and Service – as outlined in the National Honor Society Handbook.
- Must maintain a 3.5 cumulative GPA
- Have no more than 4 excused absences from meetings and activities and no unexcused absences.
- Participate in 2 community service projects over the course of membership.
- Maintain the principals of Service, Leadership, and Character
- Officers must uphold the duties of their office or be subject to dismissal.
- Members who do not meet all expectations will be notified of pending dismissal.

##### *MEETINGS:*

- Meeting times are specified in the bylaws. The chapter advisor and the chapter officers make up the executive committee and meet regularly to discuss chapter business and plan meetings.

##### *DUES:*

- Annual dues may be collected as stated in the National Honor Society Handbook.

##### *DISMISSAL:*

- A member having an infraction will be notified of pending dismissal.
- May face dismissal if laws of active membership are not followed.

(Established by the NHS Faculty Council along with the NHS Advisor, Rachelle Cox, in February 2000. Sources of information include the following: NHS Handbook Norton Community High School NHS guidelines, and Clear Creek High School NHS guidelines, and Englewood High School NHS bylaws.)

#### **NEW YORK – WASHINGTON TRIP POLICY**

The New York – Washington D.C. Trip is a school – sponsored activity. The school will sponsor this trip by providing release time and at least one supervisor to assist in discipline and observation. The following guidelines will apply to this trip:

1. The school sponsors this trip; therefore, all school rules will apply.
2. Only juniors and seniors are eligible for this activity.
3. Students participating in this activity agree to abide by the rules established by the trip's organizer/director.

4. The person going as the school representative shall have the authority to judge the actions and determine whether policies have been violated. They will have the authority to determine the proper response on the trip and will report all violations to the administration upon returning from the trip. All rules violations will be dealt with in the same manner as if the violation had occurred during school hours.
5. Before going on the trip, each student will have to meet certain eligibility requirements. Eligibility will be based upon first semester grades and discipline referrals. To be eligible academically, a student must have met the standards as prescribed by the Kansas State High School Activities Association. In addition, students who have been discipline problems during the school year will have their situation reviewed to determine the advisability of allowing them to take part in this activity.
6. All students will make up all of their work in advance. Special assignment sheet will be circulated to all teachers who have students going, and copies will be made available to each student. All work not completed may be recorded as a 0%.

**SENIOR END OF YEAR POLICY**

In order for Seniors to earn an early release at the end of the school year, each senior must meet the following conditions:

1. demonstrate good behavior,
2. follow the attendance (NO Senior Skip Day) and tardy policies, and
3. maintains acceptable classroom behavior.

The earned early release may be up to five days prior to the regularly scheduled end of the school year. The day for early release will be determined by the superintendent. Individual seniors failing to comply with this policy can still walk at graduation but may have their diplomas held until they have met the attendance requirements set by the superintendent.

**6 – 12 HANDBOOK AWARENESS STATEMENT**

My Signature below indicates that I have received and read the Student Handbook, Activity Handbook, the Consent and Warning to Athlete and Parent/Guardian, and the Code of Conduct found on pages \_\_\_\_\_ of the Student Handbook.

**INSURANCE AWARENESS**

I also recognize that interscholastic activities involve the risk of injury to the participant, which on occasion could be serious. The school does have accident insurance; however, all expenses incurred must first be submitted to the parent/guardian’s insurance company for payment. Expenses not covered by the parent/guardian’s insurance can then be referred to the insurance carrier of the school district (Student Assurance Services, Inc.). **Expenses not covered by either will become the final responsibility of the parent/guardian. Accidents or injury must be reported in a timely manner. The school insurance will not cover expenses for injuries, which occur as a result of horseplay or fighting. In case of accident or injury, coaches/sponsors and other certified school personnel are hereby authorized to provide first aid and arrange for such other emergency treatment they consider necessary.**

Parents should inform the school of changes in residence, custody, phone, work and emergency telephone numbers.

Student Name (PRINT) \_\_\_\_\_

Student Signature \_\_\_\_\_

Date \_\_\_\_\_ Grade \_\_\_\_\_

Parent’s Signature \_\_\_\_\_

Date \_\_\_\_\_

**STUDENT COMPUTER/INTERNET USAGE AGREEMENT**

My signature below indicates that I have received and read the Computer Usage policy found on page \_\_\_\_\_ of the Student Handbook.

**Please check the appropriate response:**

\_\_\_\_\_ My student may use the computers/Internet while at school pursuant to board policy, and agrees to abide by the rules of the policy.

\_\_\_\_\_ My student may not use the computers/Internet while at school.

Parent's Signature \_\_\_\_\_

Date \_\_\_\_\_

Student Name (PRINT) \_\_\_\_\_

Student Signature \_\_\_\_\_

**PLEASE RETURN THIS SIGNED FORM PAGE TO YOUR FIRST PERIOD TEACHER THE FIRST WEEK OF SCHOOL.**

**Northern Valley 6 - 12 Transportation Waiver  
Not Required for Parent(s) or Legal Guardian(s)**

Date: \_\_\_\_\_

This to certify that \_\_\_\_\_ has my permission to ride from the \_\_\_\_\_  
(Student Name)  
\_\_\_\_\_ activity contest on \_\_\_\_\_ 20\_\_\_\_, at \_\_\_\_\_  
(Activity) (Date) (Location)

I certify that I have made arranged transportation with \_\_\_\_\_ for this student.

**(Non-student Adult transportation)**

I understand that the Northern Valley 6 - 12 Activity Rules require students to ride the bus or transportation to and from all activity events and departure from this requirement will release the Northern Valley School District from all liability for any adverse results that may occur.

I agree to release the Northern Valley School District and its employees and administrators from all liability with reference to the above-stated transportation.

This form must be on file with the Activity Director prior to the dismissal of school on the day of the contest.  
**(Parent/Guardian must sign this form; phone call requests will not be accepted)**

Parents will be called to verify permission.



## Lines of Effective Communication

Area of Concern	First Level	Second Level	Third Level	Fourth Level	Fifth Level
Athletics	<b>Coach</b>	<b>Athletic Director</b>	<b>Principal</b>	<b>Supt.</b>	<b>Board of Education</b>
Curriculum/Academic / Instruction	<b>Teacher</b>	<b>Principal</b>	<b>Supt.</b>	<b>Board of Education</b>	
Discipline	<b>Teacher</b>	<b>Principal</b>	<b>Supt.</b>	<b>Board of Education</b>	
Facilities	<b>Principal</b>	<b>Supt.</b>	<b>Board of Education</b>		
Guidance	<b>Student Success Coord.</b>	<b>Principal</b>	<b>Supt.</b>	<b>Board of Education</b>	
Special Education	<b>Teacher</b>	<b>Principal</b>	NCKSEC	<b>Supt.</b>	<b>Board of Education</b>
Student Concerns	<b>Teacher</b>	<b>Principal</b>	<b>Supt.</b>	<b>Board of Education</b>	
Computer / Technology	<b>Teacher</b>	<b>Technology Director</b>	<b>Principal</b>	<b>Supt.</b>	<b>Board of Education</b>
Transportation	<b>Driver</b>	<b>Transportation Director</b>	<b>Principal</b>	<b>Supt.</b>	<b>Board of Education</b>
Custodial / Maintenance	<b>Principal</b>	<b>Supt.</b>	<b>Board of Education</b>		