

City of Beatrice, Nebraska  
Beatrice Regular City Council Meeting  
Monday, June 15, 2026 at 6:00 PM  
BPS Administration Building Board Room  
320 N 5th Street  
Beatrice, NE 68310



## Pledge of Allegiance

1. **PLEDGE OF ALLEGIANCE**
2. **ROLL CALL**
3. **CONSENT AGENDA**
  - 3.a. Approve agenda as submitted.
  - 3.b. Receive and place on file all notices pertaining to this meeting.
  - 3.c. Receive and place on file all materials having any bearing on this meeting.
  - 3.d. Approval of minutes of regular meeting on June 1, 2026, as on file in the City Clerk's Office.
  - 3.e. Approval of Treasurer's Report of Claims in the amount of \$903,273.55.
  - 3.f. Approval of BASWA Report of Claims in the amount of \$85,569.09.
  - 3.g. Approval of BPW Report of Claims in the amount of \$751,171.47.
  - 3.h. Approval of Pay Request #10 in the amount of \$38,989.16 to Building Crafts, Inc., for the WPC Grit Improvements project.
  - 3.i. Approval of Final Pay Request #14 in the amount of \$40,569.17, to Genesis Contracting Group for the BASWA South MSW Landfill Site Entrance Facility project.
  - 3.j. Resolution Number 7804 approving a request from the Gage Development Coalition to close Highway 136, which is also known as Court Street, from 3rd Street to 19th Street, on Saturday, June 27, 2026, between 8:00 a.m. until 12:30 p.m. for the Homestead Days Parade.
4. **PUBLIC HEARINGS/BIDS**
  - 4.a. Public Hearing for the purpose of considering the application of Dakuhl Investments, LLC, dba, Vinny's Alchemy & Spirits, 205 North 19th Street, Beatrice, Nebraska, for a new application for a Class C liquor license.
5. **RESOLUTIONS**
  - 5.a. Resolution Number 7805 executing the Deliverable Capacity Transaction Agreement with the City of Superior, Nebraska, as recommended by the Board of Public Works.
  - 5.b. Resolution Number 7806 executing the Utility Infrastructure & Ownership Maintenance Agreement with Southeast Community College Area, as recommended by the Board of Public Works.
  - 5.c. Resolution Number 7807 prohibiting parking along the east side of 7th Street, from Perkins to Scott Street; along the west side of 8th Street, from Perkins to Scott Street; and along the north side of Perkins Street, from 7th to 8th Street.
  - 5.d. Resolution Number 7808 executing the Environmental Services Agreement between the City and JEO Consulting Group, Inc., for the Beatrice Court

Street Access and Safety Transformation (“CAST”) Initiative, Project DPS-34(46), CN 13608.

- 5.e. Resolution Number 7809 executing the Loan Agreement, Promissory Note, Personal Guaranty, Deed of Trust, and all other documents necessary between the City and Hydo Properties, LLC and Todd A. Hydo and Soni Hydo, for a direct loan in the amount of \$62,981.25 from the City’s CDBG Downtown Revitalization Grant (23-DTR-002).
- 5.f. Resolution Number 7810 executing the Third Amendment to Redevelopment Agreement for the Lincoln School Redevelopment Project.
- 5.g. Resolution Number 7811 executing the Third Amendment to Redevelopment Agreement for the Paddock Lane Redevelopment Project.
6. **ORDINANCES** - None
7. **DISCUSSIONS/REPORTS**
  - 7.a. City Administrator’s Monthly Report.
8. **EXECUTIVE SESSION** - Contract Negotiations
9. **MISCELLANEOUS**
  - 9.a. The next regular City Council meeting is July 6, 2026 at 6:00 p.m. in the BPS Administration Building Board Room.

## **NOTICE OF MEETING**

Notice is hereby given that a meeting of the Mayor and Council of the City of Beatrice, Nebraska will be held at 6:00 P.M. on June 15, 2026, in the BPS Administration Building Board Room, 320 North 5<sup>th</sup> Street, Beatrice, Nebraska, and will be open to the public. An agenda for such meeting is available for public inspection at the office of the City Clerk, 400 Ella Street, Beatrice, Nebraska, and on the City website, [www.beatrice.ne.gov](http://www.beatrice.ne.gov).

Erin Saathoff, MMC, City Clerk

June 10, 2026

JUNE 1, 2026

6:00 P.M.

---

The Mayor and City Council of the City of Beatrice, Nebraska met in regular session in the BPS Administration Building Board Room, 320 North 5<sup>th</sup> Street, Beatrice, Nebraska on the 1<sup>st</sup> day of June, 2026, beginning at 6:00 p.m.

Notice of this meeting was given in advance thereof by publication in the Beatrice Daily Sun on May 27, 2026, a copy of the proof of publication being on file in the City Clerk's office. Notice of this meeting was simultaneously given to the Mayor and all members of the City Council and a copy of their acknowledgement of receipt of the advance notice and agenda is filed in this office. Availability of the agenda was communicated in the advance notice and in the notice to the Mayor and City Council of this meeting. All proceedings hereafter shown were taken while the convened meeting was open to the attendance of the public.

Mayor Morgan led those in attendance in the Pledge of Allegiance.

#### ROLL CALL

Attending: Mayor Morgan, Councilmembers: Barnard, Doyle, Eckhoff, Eskra, Fairbanks, Hydo, McLain, Ruh

Absent: None

Mayor Morgan announced that a copy of the Open Meetings Act is posted in the meeting room and is accessible to members of the public.

#### CONSENT AGENDA

- a. Approve agenda as submitted.
- b. Receive and place on file all notices pertaining to this meeting.
- c. Receive and place on file all materials having any bearing on this meeting.
- d. Approval of minutes of regular meeting on May 18, 2026, as on file in the City Clerk's Office.
- e. Approval of Treasurer's Report of Claims in the amount of \$1,025,209.46.
- f. Approval of BASWA Report of Claims in the amount of \$24,318.94.
- g. Approval of BPW Report of Claims in the amount of \$1,299,134.50.
- h. Approval of Pay Request #9 in the amount of \$67,093.37 to Building Crafts, Inc., for the WPC Grit Improvements project, as recommended by the Board of Public Works.
- i. Approval of Pay Request #9 in the amount of \$28,995.12 to Van Kirk Brothers Contracting for the 2025 Heritage Heights Addition project, as recommended by the Board of Public Works.
- j. Approval of Change Order #4 decrease in the amount of \$11,607.85 and Final Pay Request #7 in the amount of \$51,710.73 to Van Kirk Brothers Contracting for the 2025 Corral Crossing Addition project, as recommended by the Board of Public Works.
- k. Approval of Change Order #1 increase in the amount of \$66,097.45 to Midlands Contracting, Inc., dba Johnson Service Co., for the Sanitary Sewer Lining & Manhole Rehabilitation 2025 project.

- l. Resolution Number 7800 executing the Sponsorship Agreement with First State Bank Nebraska for Hannibal Park.
- m. Resolution Number 7801 executing the Agreement for Professional Services between the City and JEO Consulting Group, Inc., for review of the City's Industrial Storm Water (ISW) Stormwater Pollution Prevention Plan (SWPPP) to ensure the existing ISW SWPPP covers all requirements of the current NPDES ISW General Permit and for SWPPP training.
- n. Resolution Number 7802 executing the Agreement between the City and SewerAI for the provision of software designed for sewer and stormwater inspection data management.

Moved by McLain, seconded by Fairbanks, that the items listed under the consent agenda, be approved, accepted, and/or ratified as presented.

Roll Call: Yea: Barnard, Doyle, Eckhoff, Eskra, Fairbanks, Hydo, McLain, Ruh  
Nay: None

MOTION CARRIED.

### **PUBLIC HEARINGS/BIDS**

#### **Public Hearing for the purpose of considering the application of B&R Stores, Inc., dba, Russ's Market #48, 1815 Court Street, Beatrice, Nebraska, for a new application for a Class C liquor license**

Mayor Morgan announced that a public hearing will now be held for the purpose of considering the application of B&R Stores, Inc., dba, Russ's Market #48, 1815 Court Street, Beatrice, Nebraska, for a new application for a Class C liquor license.

Chet McGrury, Community Development Director, under oath, reported there were no issues found in the planning report conducted by the Community Development Department and there are no foreseeable issues or concerns.

Tobias J. Tempelmeyer, City Administrator/General Manager, under oath, reported to the Council there was nothing found in the standard background investigation completed by Sgt. Byrne to prohibit the issuance of this license.

Moved by McLain seconded by Fairbanks, that the public hearing be closed at 6:05 p.m.

Roll Call: Yea: Barnard, Doyle, Eckhoff, Eskra, Fairbanks, Hydo, McLain, Ruh  
Nay: None

MOTION CARRIED.

Moved by McLain, seconded by Fairbanks, that the application of B&R Stores, Inc., dba, Russ's Market #48, 1815 Court Street, Beatrice, Nebraska, for a Class C liquor license, be recommended to the Nebraska Liquor Control Commission for approval.

Roll Call: Yea: Barnard, Doyle, Eckhoff, Eskra, Hydo, McLain, Ruh  
Nay: Fairbanks

MOTION CARRIED.

**Public Hearing for the purpose of considering the acquisition of real property from Benjamin Prebyl, legally described as follows: Lot Eleven (11), Block 60, Beatrice Original, Beatrice, Gage County, Nebraska, commonly, known as 820 Market Street, Beatrice, Nebraska, Parcel ID No: 009827000**

Mayor Morgan announced that a public hearing will now be held for the purpose of considering the acquisition of real property from Benjamin Prebyl, legally described as follows: Lot Eleven (11), Block 60, Beatrice Original, Beatrice, Gage County, Nebraska, commonly, known as 820 Market Street, Beatrice, Nebraska, Parcel ID No: 009827000.

Tobias J. Tempelmeyer, City Administrator/General Manager, reported to the Council approximately five (5) years ago there was a house fire at this address. Benjamin Prebyl has agreed to donate the property to the City, as well as paying the back taxes. Tempelmeyer stated the City will demolish the house and has no plans for the property at this time.

Jim Nelson, 1025 North 6<sup>th</sup> Street, thanked Administration for putting the agenda packet online prior to the meeting so the public was informed this was a donation and no cost to the City.

Moved by McLain, seconded by Fairbanks, that the public hearing be closed at 6:07 p.m.

Roll Call: Yea: Barnard, Doyle, Eckhoff, Eskra, Fairbanks, Hydo, McLain, Ruh  
Nay: None

MOTION CARRIED.

### RESOLUTIONS

**Resolution Number 7803 executing the Contract for Donation of Real Estate and all necessary documents to acquire real estate from Benjamin Prebyl**

Mayor Morgan introduced Resolution Number 7803 executing the Contract for Donation of Real Estate and all necessary documents to acquire real estate from Benjamin Prebyl.

There was no further discussion by the Council or public.

Moved by McLain, seconded by Fairbanks, that Resolution Number 7803 be passed and adopted.

Roll Call: Yea: Barnard, Doyle, Eckhoff, Eskra, Fairbanks, Hydo, McLain, Ruh  
Nay: None

MOTION CARRIED.

**RESOLUTION NUMBER 7803 – Passed and Adopted – executing the Contract for Donation of Real Estate and all necessary documents to acquire real estate from Benjamin Prebyl**  
*Incorporated into the Minute Record by Reference*

### ORDINANCES

There were no ordinances.

### DISCUSSIONS/REPORTS

#### Beatrice Humane Society Update

Steph Clark, President of the Humane Society Board of Directors, Deanne Caspers-Moon, President of the Humane Society Foundation, and Carlee Fiddes, Humane Society Executive Director, gave an update on the Beatrice Humane Society to the Council. Clark thanked the Council for partnering with the Humane

Society three (3) years ago to participate in the trap, neuter, vaccinate, and release (TNVR) program to address the stray and feral cat issue in Beatrice. Clark stated the program has been successful, noting Beatrice was the first community to partner with the Humane Society. Other communities, such as Wymore, Fairbury, and Crete, have reached out with interests of partnering with the Humane Society to address similar issues within their community.

Fiddes reported a total of sixty-three (63) cats were treated with the TNVR program with the City's contribution in 2025 and approximately thirty-two (32) different residents benefited from the program. Fiddes stated this is the first year no kittens were brought into the Clinic before May, which can be attributed to the TNVR program.

Councilmember Barnard inquired how long the TNVR program has to continue to be a success. Fiddes stated if they were to stop the TNVR program now, it would need to restart within five (5) years. Fiddes inquired how many complaints have been received by the City within the last year and Tobias J. Tempelmeyer, City Administrator/General Manager, stated he has received no complaints of stray or feral cats this past year.

Councilmember Eskra inquired what percentage Fiddes believes the City's TNVR program rate is at and where she would like to see it be. Fiddes stated she believes Beatrice's population has been addressed by approximately forty percent (40%) to fifty percent (50%), however, she would like to see the population treated at ninety percent (90%). Fiddes noted the intake of cats is much more manageable than it was five (5) years ago, with approximately five hundred (500) cats being brought in from Beatrice annually.

Tempelmeyer asked for clarification that the sixty-three (63) cats treated through the program do not include cats from other communities and Fiddes stated the sixty-three (63) cats treated were only from Beatrice. Fiddes noted approximately two hundred (200) cats were brought in last year. Fiddes stated some residents were willing to cover the cost and adopted the cat after being spayed or neutered, if they brought in a cat that did not have behavioral issues.

Councilmember Hydo stated she has been involved with the Humane Society since it opened and she recalls having to transport numerous cats to Auburn to have them spayed or neutered, noting how nice it is to have a clinic in Beatrice now. Councilmember Hydo asked Fiddes to speak about the Humane Society being a no-kill shelter. Fiddes reported the Humane Society has a save rate of approximately 98.1%, which is very unique. Fiddes stated the Shelter had 1,517 adoptions in 2025, which is the seventh straight record-breaking year. Fiddes stated Beatrice is leading the charge to be able to place animals into a home. Fiddes noted the Shelter has also developed a protocol for treating several diseases to prevent them from spreading. Fiddes reported Marysville, Kansas, reached out last year for assistance on opening a shelter. Councilmember Hydo stated the Council has talked about how important it is that we are leading the charge in so many areas, and this is no different, as the work we are doing not only helps Beatrice, but it is helping out other communities as well.

## **ADJOURNMENT**

The next regular City Council meeting is June 15, 2026 at 6:00 p.m. in the BPS Administration Building Board Room.

Moved by McLain, seconded by Fairbanks, that the meeting be adjourned at 6:31 p.m.

Roll Call: Yea: Barnard, Doyle, Eckhoff, Fairbanks, Hydo, McLain, Ruh

Nay: None

MOTION CARRIED.

---

Erin Saathoff, MMC, City Clerk

---

Robert Morgan, Mayor

**City Claims approved as follows:** (*Abbreviations are: Ex, Expenses; Fe, Fees; Re, Reimbursement; Se, Services; Su, Supplies*): 911 Custom, Ex, \$2,090.00; Adams Rural Fire District, Re, \$5,938.32; Adams Village Of, Re, \$2,862.05; Aed Superstore, Su, \$419.00; Alder, Lathan, Re, \$349.95; All Copy Products, Se, \$132.67; Aqua-Chem, Inc, Su, \$845.92; Auto Repair Plus, Se, Su, \$1,215.38; Barneston Rural Fire District, Re, \$4,708.81; Beatrice Community Hospital, Fe, \$500.00; Beatrice Humane Society, Re, \$1,000.00; Beatrice Iron And Metal Co, Su, \$255.93; Beatrice Mechanical Serv Inc, Se, \$150.00; Beatrice Public Schools, Re, \$2,725.00; Beatrice Ready Mixed, Su, \$15,219.35; Beatrice Rural Fire Dept, Re, \$11,240.34; Beatrice Sand And Gravel, Su, \$2,416.80; Bird, Michael, Re, \$50.00; Black Hills Energy, Se, \$1,059.83; Blue Springs Fire District, Re, \$3,789.05; Blue Springs, City, Re, \$807.84; Bomgaars Supply Inc, Su, \$224.68; Bond Owner, Ex, \$57,287.50; Bound Tree Medical Llc, Su, \$1,178.86; Bragg, Robert, Se, \$6,000.00; Bryan Health - Health Information Mgmnt, Fe, \$21.40; Bryan's Auto Body, Se, Su, \$540.00; Carolina Software, Inc, Ex, \$13,850.00; Carpenter Paper Co, Su, \$64.51; Cary's Cleaning, Se, \$4,920.00; Cash-Wa Distributing, Su, \$4,906.27; Centurylink Communications Llc, Se, \$3,379.40; Charter Communications, Se, \$12.33; City Motor Supply, Su, \$209.71; City Service Valcon Llc, Su, \$36,714.61; City Treas. Petty Cash, Re, \$108.52; Clatonia Fire District, Re, \$1,522.30; Clatonia Village Of, Re, \$3,295.38; Column Software Pbc, Fe, \$462.09; Cornhusker State Industries, Su, \$218.10; Cortland Lancaster Rural Fire, Re, \$4,121.33; Cortland Village Of, Re, \$1,793.18; Datashield Corporation, Se, \$109.06; Diode Technologies Llc, Se, \$324.74; Eakes, Inc, Su, \$654.30; Echosat, Inc, Fe, \$133.00; Endicott Clay Products Company, Su, \$816.00; Environmental Maintenance Services Llc, Se, \$456.65; Exmark Manufacturing Co, Inc, Ex, \$28,000.00; Fairbury Winnelson Co, Su, \$314.39; Filley Rural Fire District, Re, \$4,105.18; First Wireless Inc, Se, \$1,039.53; Firststar Fiber Inc, Se, \$4,192.10; Fowler, Aaron, Se, \$425.00; Gage County Register Of Deeds, Fe, \$76.00; Galls Llc, Su, \$123.50; Gb Auto Service Inc, Se, Su, \$1,212.91; George Ulrick Iii Forklift Service, Se, Su, \$366.98; Glasco, Billie, Re, \$233.30; Gonzales, Rebecca, Re, \$150.00; Grainger, Su, \$317.88; Hawkins Inc, Su, \$132.46; Heartland Business Systems Llc, Se, \$441.00; Holmes, Seth, Re, \$559.92; Inland Truck Parts And Service, Su, \$526.59; Interstate Power Systems, Inc, Se, Su, \$9,864.51; Jeo Consulting Group Inc, Ex, \$3,453.75; Jerry Carter, Se, \$2,190.00; Johnny's Welding Inc, Se, Su, \$7,845.58; Jon's Outdoor Service, Se, \$72.36; Joshua B Repogle, Se, \$2,800.00; Lammel Plumbing Inc, Su, \$19.14; Larry's Tire And Service Inc, Se, Su, \$40.00; Martin Resource Management, Su, \$354.75; McMurphy, Amanda, Re, \$60.47; Mead Lumber And Rental-Beatrice, Su, \$265.65; Merchant Mcintyre & Assoc Llc, Fe, \$8,000.00; Nebraska State Fire Marshall, Se, \$360.00; Nmc, Inc, Se, Su, \$2,812.30; North Central Emergency Vehicles, Su, \$194.88; Nutrien Ag Solutions, Su, \$495.00; Odell Rural Fire District, Re, \$6,286.14; Odell, Village Of, Re, \$832.30; O'reilly Auto Parts, Su, \$259.23; Pepsi Cola Of Lincoln, Su, \$1,614.46; Pickrell Rural Fire District, Re, \$4,599.30; Pickrell Village Of, Re, \$665.76; Precision Auto Tune Inc, Se, Su, \$522.56; Premier Mower & Powersports Llc, Su, \$48.53; Priority Printing, Su, \$114.50; Pro-Trainer Inc, Ex, \$108,712.00; Rdo Truck Center Co, Ex, \$259,445.02; Refuse Inc, Su, \$1,968.22; Sack Lumber Company, Su, \$8.58; Sapp Brothers, Su, \$10,503.86; Schuster's Outdoor And Rv Inc, Su, \$565.04; Siteone Landscape Supply, Llc, Su, \$283.58; Springfield Electric Supply Company Llc, Su, \$120.60; State Fire Marshal Training Division, Fe, \$50.00; Sunny Smith, Se, \$900.00; Teleflex Llc, Su, \$3,325.00; Tk Elevator Corp, Se, \$1,656.06; Tractor Supply, Su, \$119.71; Trizetto

Provider Solutions, Se, \$132.25; Truck Center Companies, Se, Su, \$918.48; Unite Private Networks Llc, Se, \$78.40; Van Kirk Sand & Gravel Inc, Ex, \$80,705.85; Verizon Wireless, Se, \$2,819.08; Vogts Parga Construction Llc, Ex, \$270,490.26; Walker Uniform Rental, Se, \$176.19; Westlake Ace Hardware, Su, \$565.27; Windstream, Se, \$710.71; Witmer Public Safety Group, Inc, Su, \$557.18; Worldpay, Fe, \$122.03; Wymore City Of, Re, \$3,917.57; Wymore Rural Fire District, Re, \$3,589.39

**BPW Claims approved as follows:** (*Abbreviations are: Ex, Expenses; Fe, Fees; Re, Reimbursement; Se, Services; Su, Supplies*): Acco Unlimited Corporation, Su, \$2,772.64; American Electric Power, Se, \$664,852.16; Apx Inc, Fe, \$2,000.00; Beatrice Iron And Metal, Su, \$87.99; Beatrice Ready Mixed, Su, \$1,110.23; Beatrice Valvoline Express Care, Se, Su, \$136.09; Blue Valley Door Co., Inc., Se, Su, \$2,795.00; Bomgaars Supply Inc, Su, \$53.92; Border States Industries, Inc, Su, \$4,326.67; Building Crafts Inc, Su, \$67,093.37; Cary D Udell, Se, \$1,375.88; Cintas Loc 749, Se, \$70.00; Circuit Breaker Sales Llc, Su, \$801.64; City Treasurer, Re, \$344.65; Datashield Corporation, Se, \$54.53; Fastenal Company, Su, \$2.00; Gb Auto Service Inc, Se, \$49.99; Husker Electric Supply, Su, \$851.64; Hydro Optimization And Automat, Inc, Se, \$6,878.51; Jason Schmale Lawn & Landscape, Se, Su, \$2,350.01; Johnny's Welding, Inc., Se, Su, \$433.10; Mead Lumber Company, Su, \$224.71; Ne Department Of Revenue, Fe, \$89,944.66; Nebraska Dept. Environment And Energy, Fe, \$146,203.82; Nebraska Public Health Environmental Lab, Se, \$798.00; Nextera Energy Resources, Se, \$236,544.61; North American Electric Reliability Corp, Fe, \$3,541.68; O'reilly Automotive, Inc., Su, \$345.16; Polydyne, Inc., Su, \$3,114.00; Quadiant Leasing Usa Inc, Se, \$884.64; Sapp Bros. Petroleum, Inc., Su, \$5,347.70; Sunbelt Solomon Services, Llc, Su, \$625.00; The Wilson Bohannan Padlock Company, Su, \$483.40; Tractor Supply Company, Su, \$350.66; Tyndale Company, Inc., Su, \$592.17; Viking Painting Llc, Se, \$13,000.00; Western Area Power Administration, Se, \$38,307.88; Westlake Hardware, Inc., Su, \$386.39

Vendor	Vendor Name	Invoice Number	Description	Invoice Date	Net Invoice Amount
<b>GENERAL FUND</b>					
12462	BEATRICE COMMUNITY HOSPITAL FO	BENCH	Bench f/Cancer Garden	06/03/2026	1,350.00
Total :					1,350.00
<b>ADMINISTRATION</b>					
960	BEATRICE HUMANE SOCIETY	JUNE 2026	Monthly Contractual Service Fee	06/01/2026	5,000.00
1350	BOARD OF PUBLIC WORKS	86-11937	City Admin postage - May26	05/29/2026	356.03
1350	BOARD OF PUBLIC WORKS	86-11937	Ambulance postage - May26	05/29/2026	169.84
9650	CARDMEMBER SERVICE	0077-FY26	Meal f/IIMC Conf - Saathoff	05/22/2026	30.54
9650	CARDMEMBER SERVICE	0705	Meal f/IIMC Conf - Saathoff	05/21/2026	28.40
9650	CARDMEMBER SERVICE	0952	Meal f/IIMC Conf - Saathoff	05/17/2026	29.67
9650	CARDMEMBER SERVICE	2946	Meal f/IIMC Conf - Saathoff	05/21/2026	24.19
9650	CARDMEMBER SERVICE	3000-FY26	Meal f/IIMC Conf - Saathoff	05/16/2026	23.41
9650	CARDMEMBER SERVICE	3172-FY26	Luggage fee f/IIMC Conf - Saathoff	05/16/2026	35.00
9650	CARDMEMBER SERVICE	4752-FY26	Meal f/IIMC Conf - Saathoff	05/20/2026	28.41
9650	CARDMEMBER SERVICE	4767	Lodging f/IIMC Conf - Saathoff	05/22/2026	1,029.00
9650	CARDMEMBER SERVICE	5689	Pryor+ 12-mth OnDemand Access	05/06/2026	170.93
9650	CARDMEMBER SERVICE	6229	Beatrice Daily Sun monthly subscription	05/19/2026	38.99
9650	CARDMEMBER SERVICE	6488	Meal f/IIMC Conf - Saathoff	05/20/2026	9.20
9650	CARDMEMBER SERVICE	6886	Luggage fee f/IIMC Conf - Saathoff	05/22/2026	40.00
9650	CARDMEMBER SERVICE	8295	coffee maker	05/13/2026	133.30
9650	CARDMEMBER SERVICE	8341	1) 8.5x11 frame f/Proclamations	05/04/2026	32.98
9650	CARDMEMBER SERVICE	8701	Meal f/IIMC Conf - Saathoff	05/17/2026	19.24
9650	CARDMEMBER SERVICE	9440	Stamps f/Anniversary cards	05/04/2026	78.00
2060	CITY SELF INSURED HEALTH PLAN	JUNE 2026	Admin Health Insurance Funding	06/01/2026	25,200.00
2080	CITY TREASURER	JUN26-IT GENERAL	IT Services	06/01/2026	10,810.00
12490	COLUMN SOFTWARE PBC	7FF24556-0719	Notice of P&Z Mtg - 6/1/26	04/24/2026	9.06
12490	COLUMN SOFTWARE PBC	7FF24556-0720	Notice of Mtg - 6/1/26	04/24/2026	9.63
12490	COLUMN SOFTWARE PBC	7FF24556-0726	Notice of CC Public Hearing f/Prebyl Property Donati	05/14/2026	10.76
12490	COLUMN SOFTWARE PBC	7FF24556-0728	Ord 26-19	05/05/2026	20.39
12490	COLUMN SOFTWARE PBC	7FF24556-0731	Notice of P&Z Public Hearing f/SUP D'Andrea	05/26/2026	13.59
12490	COLUMN SOFTWARE PBC	7FF24556-0732	Notice of P&Z Mtg - 6/15/26	05/27/2026	9.06
12490	COLUMN SOFTWARE PBC	7FF24556-0733	Notice of Mtg - 6/15/26	05/27/2026	9.63
12490	COLUMN SOFTWARE PBC	7FF24556-0735	Notice of CC Public Hearing f/Liquor License Vinny's	06/01/2026	13.59
12490	COLUMN SOFTWARE PBC	7FF24556-0736	CC Minutes - 5/18/26	06/01/2026	245.77
12398	Dvorak Law Group, LLC	124204	Vogts-Parga Construction Dispute - File #1008040-00	06/08/2026	1,985.00
12398	Dvorak Law Group, LLC	124539	General Business - File # 1008040-0005	06/05/2026	140.00
3590	GAGE COUNTY CLERK	2026 PRIM. ELECTION	2026 City Share Primary Election Ballot	06/03/2026	2,626.41
3680	GAGE COUNTY REGISTER OF DEEDS	05192026	Dor Ortiz	05/19/2026	16.00
3680	GAGE COUNTY REGISTER OF DEEDS	05202026	DOT 117-123 South 5th Street LLC	05/20/2026	22.00
3680	GAGE COUNTY REGISTER OF DEEDS	05212026	Ease Kinney Holdings LLC	05/21/2026	28.00
3680	GAGE COUNTY REGISTER OF DEEDS	05222026	Agmt Northgate Campus Two LLC	05/22/2026	16.00
3680	GAGE COUNTY REGISTER OF DEEDS	05292026	Ord Homestead Junction Third Add	05/29/2026	22.00
3680	GAGE COUNTY REGISTER OF DEEDS	05292026	Plat Homestead Junction Third Add	05/29/2026	40.00
3680	GAGE COUNTY REGISTER OF DEEDS	05292026	Ord Homestead Junction Third Add	05/29/2026	22.00
3680	GAGE COUNTY REGISTER OF DEEDS	06022026	Ease Zephyr Towers LLC	06/02/2026	22.00
3700	GAGE COUNTY TREASURER	0009827000 - 2025 TAX	820 Market - 0009827000 2025 Real Estate Taxes	06/08/2026	171.46
3700	GAGE COUNTY TREASURER	708 MARKET - 1ST HALF	2025 1st half property taxes - 708 Market	05/29/2026	120.66
3920	Government Finance Officers Assoc	3137384	Registration f/Capital Assets - McMurphy	05/22/2026	275.00
5470	MAIN STREET BEATRICE INC	PLUS-PLANTERS FY26	Plus Funds - downtown planters	04/21/2026	2,000.00
6600	NEBRASKA TITLE COMPANY	06082026	Owner's Policy - 820 Market	06/08/2026	150.00
11311	Paymentech	5707000-MAY26	Monthly CC Fees - City	05/31/2026	785.49
7380	PINNACLE BANK	MAY 2026	Internet Bank Fees	06/01/2026	236.50
7640	PRIORITY PRINTING	125407	10,000 "The Beat" - City Share 50%	06/05/2026	678.69
1088	Saathoff, Erin	REIMB MAY26	Reimb. Mil. - IIMC Conf	05/27/2026	149.35

Vendor	Vendor Name	Invoice Number	Description	Invoice Date	Net Invoice Amount
12738	STARLIN, DENISE E	SIDEWALK IMPROVEME	Sidewalk Improvement	05/28/2026	512.00
11312	Xpress Bill Pay	INV-XPR036118	Monthly CC Fees - City	05/31/2026	496.30
Total ADMINISTRATION:					54,143.47
<b>COMMUNITY DEVELOPMENT</b>					
840	BEATRICE AREA SOLID WASTE AGNC	236-MAY26-C	Demo - Industrial Park barn	05/31/2026	300.00
1350	BOARD OF PUBLIC WORKS	1417.40-CD-MAY26	37.61 gal Unleaded @ 2.615	06/01/2026	98.35
1350	BOARD OF PUBLIC WORKS	86-11937	Community Development postage - May26	05/29/2026	412.18
9650	CARDMEMBER SERVICE	3463	USB, tape	05/07/2026	28.31
2060	CITY SELF INSURED HEALTH PLAN	JUNE 2026	Insp. Health Insurance Funding	06/01/2026	8,400.00
2080	CITY TREASURER	JUN26-IT GENERAL	IT Services	06/01/2026	258.00
Total COMMUNITY DEVELOPMENT:					9,496.84
<b>POLICE ADMINISTRATION</b>					
9650	CARDMEMBER SERVICE	1297	Membership f/International Assc of Chiefs of Police	05/23/2026	220.00
9650	CARDMEMBER SERVICE	4453	expo dry erase makers, cleaner, pens, sharpie	05/02/2026	46.66
9650	CARDMEMBER SERVICE	6519-FY26	Lunch w/a Cop	05/11/2026	180.60
9650	CARDMEMBER SERVICE	9512	chair f/Captain's office	05/01/2026	107.49
2060	CITY SELF INSURED HEALTH PLAN	JUNE 2026	PD Health Insurance Funding	06/01/2026	6,300.00
2080	CITY TREASURER	JUN26-IT GENERAL	IT Services	06/01/2026	168.00
Total POLICE ADMINISTRATION:					7,022.75
<b>POLICE VAC</b>					
2060	CITY SELF INSURED HEALTH PLAN	JUNE 2026	VAC Health Insurance Funding	06/01/2026	2,800.00
Total POLICE VAC:					2,800.00
<b>POLICE COMMUNICATIONS</b>					
9650	CARDMEMBER SERVICE	2118	paper towel, all-purpose cleaner, clorox spray	05/15/2026	12.14
9650	CARDMEMBER SERVICE	3150-FY26	3) boards f/window	05/02/2026	277.12
9650	CARDMEMBER SERVICE	4436	TV w/wall mount	05/06/2026	170.64
2060	CITY SELF INSURED HEALTH PLAN	JUNE 2026	Comm. Health Insurance Funding	06/01/2026	28,000.00
2080	CITY TREASURER	JUN26-IT GENERAL	IT Services	06/01/2026	267.00
6680	NESCA	000141	Registration f/Conf - Cooper	05/29/2026	125.00
6680	NESCA	000141	Registration f/Conf - Walton	05/29/2026	125.00
Total POLICE COMMUNICATIONS:					28,976.90
<b>POLICE PATROL</b>					
980	BEATRICE IRON AND METAL CO	114509	Labor - windshield repair	06/04/2026	40.00
1350	BOARD OF PUBLIC WORKS	1417.20-PD-MAY26	1,198.45 gal Unleaded @ 2.615	06/01/2026	3,133.95
1350	BOARD OF PUBLIC WORKS	86-11937	Police Dept postage - May26	05/29/2026	17.02
9650	CARDMEMBER SERVICE	0274-FY26	2) swat operator pin	05/15/2026	41.16
9650	CARDMEMBER SERVICE	0387-FY26	EXTREME MOTORSPORTS - Labor & supplies f/UT	05/26/2026	400.00
9650	CARDMEMBER SERVICE	0750	helium kit	05/12/2026	34.92
9650	CARDMEMBER SERVICE	0861	TRACTOR SUPPLY - 2) hose clamp, screwdriver f/U	05/28/2026	38.65
9650	CARDMEMBER SERVICE	0935	2) mount f/body camera	05/19/2026	85.98
9650	CARDMEMBER SERVICE	0935	1) glove, lg	05/19/2026	36.20
9650	CARDMEMBER SERVICE	0994-FY26	300-round) Military blank training ammo	05/12/2026	168.45
9650	CARDMEMBER SERVICE	1156-FY26	1) tactical boot, 2) combat shirt, 1) mask, 40-pc) mour	05/26/2026	375.96
9650	CARDMEMBER SERVICE	2515-FY26	7) shirt f/Carseat Event	05/05/2026	150.29
9650	CARDMEMBER SERVICE	2922 2930	credit - return PVC pipe	05/21/2026	116.01-
9650	CARDMEMBER SERVICE	2943-FY26	pvc supplies	05/21/2026	295.41
9650	CARDMEMBER SERVICE	3486	Halo Care Collar monthly subscription	05/11/2026	9.99

Vendor	Vendor Name	Invoice Number	Description	Invoice Date	Net Invoice Amount
9650	CARDMEMBER SERVICE	4876	nail spike, paint f/range	05/12/2026	63.39
9650	CARDMEMBER SERVICE	4905-FY26	50) furring strips	05/11/2026	176.84
9650	CARDMEMBER SERVICE	6940	Undercover wire minutes	05/08/2026	33.64
9650	CARDMEMBER SERVICE	7142	chair f/Sgt office	05/15/2026	368.94
9650	CARDMEMBER SERVICE	7726 4986	15) target holders	05/12/2026	644.84
9650	CARDMEMBER SERVICE	7915-FY26	pvc supplies	05/21/2026	142.44
9650	CARDMEMBER SERVICE	8137	coffee maker	05/21/2026	168.00
9650	CARDMEMBER SERVICE	8588	mini car charger	05/17/2026	161.24
2060	CITY SELF INSURED HEALTH PLAN	JUNE 2026	PD Health Insurance Funding	06/01/2026	63,700.00
2080	CITY TREASURER	ASSET 5377-2014 AMBUL	2014 Ambulance - Asset #5377	06/10/2026	500.00
2080	CITY TREASURER	JUN26-IT GENERAL	IT Services	06/01/2026	992.00
12221	GB Auto Service Inc	511716301	Labor - 4) tire mount	05/29/2026	95.96
12221	GB Auto Service Inc	511716301	Labor - alignment	05/29/2026	129.99
12221	GB Auto Service Inc	511716301	Supplies - 4) tire	05/29/2026	1,083.96
12221	GB Auto Service Inc	511716301	Shop Supplies	05/29/2026	10.40
12221	GB Auto Service Inc	511716394	Labor - 2) mount & balance	06/03/2026	47.98
12221	GB Auto Service Inc	511716394	Supplies - 2) tire	06/03/2026	471.98
12628	HARRE, MATTHEW	REIMB. MAY26	Reimb. 8) meals f/SWAT school	05/28/2026	180.73
5160	LARRY'S TIRE AND SERVICE INC.	128247	Labor - 1) tire repair	06/08/2026	30.00
12003	Oakview Veterinary Clinic	165759	2) Sensitive Stomach & Skin K-9 f/Thomas	05/28/2026	130.74
1008	TRANSUNION RISK AND ALTERNATIV	41141-MAY26	Records Search - May	06/01/2026	100.00

Total POLICE PATROL: 73,945.04

**FIRE ADMINISTRATION**

9650	CARDMEMBER SERVICE	2089	Critical Care Transport Navigate Essential	05/21/2026	192.72
9650	CARDMEMBER SERVICE	2089	Hemodynamic Monitoring	05/21/2026	88.88
9650	CARDMEMBER SERVICE	2089	The Walls Manual of Emergency	05/21/2026	94.31
9650	CARDMEMBER SERVICE	3413	Registration f/MVD Conf - Seggerman	05/13/2026	482.02
2060	CITY SELF INSURED HEALTH PLAN	JUNE 2026	FD Ad Health Insurance Funding	06/01/2026	5,600.00
2080	CITY TREASURER	JUN26-IT GENERAL	IT Services	06/01/2026	1,383.00

Total FIRE ADMINISTRATION: 7,840.93

**FIRE SUPPRESSION**

1350	BOARD OF PUBLIC WORKS	1417.30-FIRE-MAY26	99.425 gal Unleaded @ 2.615	06/01/2026	259.98
9650	CARDMEMBER SERVICE	0283-FY26	paper towels	05/25/2026	30.99
9650	CARDMEMBER SERVICE	6635-FY26	3) hand soap, 2) lysol toilet bowl cleaner, 4) pumice st	05/16/2026	29.69
9650	CARDMEMBER SERVICE	9025-FY26	dashboard phone mount kit f/FC2	05/08/2026	66.78
9650	CARDMEMBER SERVICE	9073-FY26	stencil	05/29/2026	31.98
12741	CIRCUL-AIR CORP. INTL.	CAC-WR26-060	2) breaker f/gear dryer	05/28/2026	118.70
2060	CITY SELF INSURED HEALTH PLAN	JUNE 2026	FD Health Insurance Funding	06/01/2026	47,040.00
2080	CITY TREASURER	JUN26-IT GENERAL	IT Services	06/01/2026	200.00
6430	NMC, INC	INV780966	Labor - preventative Maintenance f/generator	05/26/2026	803.00
6430	NMC, INC	INV780966	Labor - transfer stiwhc inspection f/generator	05/26/2026	674.00
12024	North Central Emergency Vehicles	0000076	Windshield, rubber molding f/E1	06/04/2026	2,194.35
12432	The Overhead Door Co of Lincoln Inc	54040	Labor - maintenance f/door	05/26/2026	270.00
12432	The Overhead Door Co of Lincoln Inc	54040	Trip Charge	05/26/2026	90.00
9730	WALKER UNIFORM RENTAL	1474492	Shop Towel Service	05/28/2026	26.70
9760	Westlake Ace Hardware	10360603	bulk fasteners f/training prop	05/29/2026	11.67
9760	Westlake Ace Hardware	10360604	2) utility knife, 2) heavy duty hook blade	05/29/2026	17.24
12740	WICHITA WATER CONDITIONING INC	239389	Labor - water softener repairs	05/31/2026	212.00
12740	WICHITA WATER CONDITIONING INC	239389	Supplies - water softener repairs	05/31/2026	104.00
12740	WICHITA WATER CONDITIONING INC	93750	Labor - water softener repairs	05/31/2026	210.00

Total FIRE SUPPRESSION: 52,391.08

Vendor	Vendor Name	Invoice Number	Description	Invoice Date	Net Invoice Amount
<b>FIRE AMBULANCE</b>					
890	BEATRICE COMMUNITY HOSPITAL	760	Laundry Service - May 2026	06/01/2026	510.00
1350	BOARD OF PUBLIC WORKS	1417.30-FIRE-MAY26	401.044 gal Diesel @ 2.708	06/01/2026	1,086.02
1350	BOARD OF PUBLIC WORKS	1417.30-FIRE-MAY26	103.611 gal Diesel @ 2.708	06/01/2026	280.60
1350	BOARD OF PUBLIC WORKS	1417.30-FIRE-MAY26	437.819 gal Unleaded @ 2.615	06/01/2026	1,144.90
1420	BOUND TREE MEDICAL LLC	86224619	6) cricothyrotomy kit	05/29/2026	575.94
1420	BOUND TREE MEDICAL LLC	86228377	2) fentanyl	06/02/2026	151.91
2010	CITY MOTOR SUPPLY	917553	tap screw f/M4	05/28/2026	8.44
2060	CITY SELF INSURED HEALTH PLAN	JUNE 2026	EMS Health Insurance Funding	06/01/2026	20,160.00
2080	CITY TREASURER	JUN26-IT GENERAL	IT Services	06/01/2026	250.00
2080	CITY TREASURER	W-O AMBUL-JUN26	W-O Ambulance bad debt - send to CA	06/09/2026	16,572.20
3210	FARMERS COOPERATIVE	200370-MAY26	Labor - LOF f/M3	05/31/2026	25.00
3210	FARMERS COOPERATIVE	200370-MAY26	Supplies - oil filter, air filter f/M3	05/31/2026	50.51
3210	FARMERS COOPERATIVE	200370-MAY26	Supplies - oil f/M3	05/31/2026	103.83
3210	FARMERS COOPERATIVE	200370-MAY26	Labor - LOF f/M2	05/31/2026	35.00
3210	FARMERS COOPERATIVE	200370-MAY26	Supplies - oil filter, air filter f/M2	05/31/2026	110.74
3210	FARMERS COOPERATIVE	200370-MAY26	Supplies - oil f/M2	05/31/2026	154.24
5110	LAMPTON WELDING SUPPLY Co., INC	0001164351	Cylinder rent - Fire	05/31/2026	585.17
5110	LAMPTON WELDING SUPPLY Co., INC	0020375901	Medical Oxygen	05/29/2026	359.83
11989	Zoellner Ford-Lincoln of Beatrice	357098	2) washer nozzle	06/03/2026	32.86
Total FIRE AMBULANCE:					42,197.19
<b>PUBLIC PROPERTIES</b>					
12352	ASSA ABLOY ENTRANCE SYSTEMS U	SEI 1987868	Labor - 2.25 hr traveling	05/21/2026	292.50
12352	ASSA ABLOY ENTRANCE SYSTEMS U	SEI 1987868	Labor - adjust sensors	05/21/2026	227.50
12352	ASSA ABLOY ENTRANCE SYSTEMS U	SEI 1987868	Supplies & hardware f/Senior Center	05/21/2026	75.00
840	BEATRICE AREA SOLID WASTE AGNC	236-MAY26-P	Pub prop - tipping fee	05/31/2026	13.29
12156	Beatrice Valvoline Express Care	28359	Labor - LOF f/06 Chevy	06/08/2026	54.99
12156	Beatrice Valvoline Express Care	28359	Supplies - oil f/06 Chevy	06/08/2026	6.76
12156	Beatrice Valvoline Express Care	28359	Shop Supplies	06/08/2026	2.47
12095	Bomgaars Supply Inc	595495	Labor - Stihl back-pack blower	06/04/2026	30.00
12095	Bomgaars Supply Inc	595495	Supplies - Stihl back-pack blower	06/04/2026	130.00
12095	Bomgaars Supply Inc	597458	Labor - Stihl pole saw	06/09/2026	28.00
2060	CITY SELF INSURED HEALTH PLAN	JUNE 2026	Pub Prop Health Insurance Fund	06/01/2026	11,200.00
2080	CITY TREASURER	JUN26-IT GENERAL	IT Services	06/01/2026	425.00
11996	Commercial Recreation Specialists	SO-0050507	activator kit f/Astro Splash Pad	05/28/2026	1,050.00
2940	Eakes, Inc.	9343644-0	1) soap	05/26/2026	35.90
2940	Eakes, Inc.	9347579-0	14) toilet paper, 10) trash bag, 13) paper towel	06/02/2026	1,377.61
12230	Earl's Window Service	05262026	Clean windows - May 26 f/Fire Station	05/26/2026	100.00
3210	FARMERS COOPERATIVE	3010-MAY26	3) tire repair f/mower	05/31/2026	30.00
3210	FARMERS COOPERATIVE	3010-MAY26	8.597 gal Premium @ 4.349	05/31/2026	37.39
3210	FARMERS COOPERATIVE	3010-MAY26	10.657 gal Premium @ 4.349	05/31/2026	46.35
3210	FARMERS COOPERATIVE	3010-MAY26	10.749 gal Premium @ 4.299	05/31/2026	46.21
3210	FARMERS COOPERATIVE	3010-MAY26	30.242 gal E15 @ 3.799	05/31/2026	114.89
3210	FARMERS COOPERATIVE	3010-MAY26	14.528 gal Super E89 @ 3.999	05/31/2026	58.10
3210	FARMERS COOPERATIVE	3010-MAY26	38.298 gal Super E89 @ 3.999	05/31/2026	153.15
3210	FARMERS COOPERATIVE	3010-MAY26	10.264 gal Premium @ 4.549	05/31/2026	46.69
3210	FARMERS COOPERATIVE	3010-MAY26	15.136 gal E15 @ 3.999	05/31/2026	60.53
3210	FARMERS COOPERATIVE	3010-MAY26	17.98 gal Super E89 @ 4.249	05/31/2026	76.40
3210	FARMERS COOPERATIVE	3010-MAY26	Supplies - 4) tire	05/31/2026	670.00
3210	FARMERS COOPERATIVE	3010-MAY26	Labor - alignment	05/31/2026	99.95
3210	FARMERS COOPERATIVE	3010-MAY26	shop supplies	05/31/2026	3.00
3210	FARMERS COOPERATIVE	3010-MAY26	Labor - R&R rotor, brake pad	05/31/2026	160.00
3210	FARMERS COOPERATIVE	3010-MAY26	Supplies - rotor, brake pad	05/31/2026	221.41
3210	FARMERS COOPERATIVE	3010-MAY26	25.757 gal Super E89 @ 4.249	05/31/2026	109.44
3210	FARMERS COOPERATIVE	3010-MAY26	15.697 gal E15 @ 3.999	05/31/2026	62.77

Vendor	Vendor Name	Invoice Number	Description	Invoice Date	Net Invoice Amount
3210	FARMERS COOPERATIVE	3010-MAY26	30.517 gal E15 @ 3.979	05/31/2026	121.43
3210	FARMERS COOPERATIVE	3010-MAY26	14.386 gal E15 @ 3.979	05/31/2026	57.24
3210	FARMERS COOPERATIVE	3010-MAY26	11.856 gal Premium @ 4.529	05/31/2026	53.70
3210	FARMERS COOPERATIVE	3010-MAY26	10.671 gal Premium @ 4.529	05/31/2026	48.33
3210	FARMERS COOPERATIVE	3010-MAY26	0.453 gal E15 @ 4.399	05/31/2026	1.99
3210	FARMERS COOPERATIVE	3010-MAY26	20.0 gal E15 @ 4.399	05/31/2026	87.98
3210	FARMERS COOPERATIVE	3010-MAY26	16.67 gal Premium @ 4.949	05/31/2026	82.50
3210	FARMERS COOPERATIVE	3010-MAY26	4.992 gal Super E89 @ 4.649	05/31/2026	23.21
3210	FARMERS COOPERATIVE	3010-MAY26	25.374 gal E15 @ 4.399	05/31/2026	111.62
3210	FARMERS COOPERATIVE	3010-MAY26	10.142 gal E15 @ 4.399	05/31/2026	44.61
3210	FARMERS COOPERATIVE	3010-MAY26	38.708 gal E15 @ 4.399	05/31/2026	170.28
3210	FARMERS COOPERATIVE	3010-MAY26	5.486 gal Premium @ 4.949	05/31/2026	27.15
3210	FARMERS COOPERATIVE	3010-MAY26	9.898 gal Premium @ 4.949	05/31/2026	48.99
3210	FARMERS COOPERATIVE	3010-MAY26	21.564 gal E15 @ 4.399	05/31/2026	94.86
3210	FARMERS COOPERATIVE	3010-MAY26	2.797 gal Premium @ 5.029	05/31/2026	14.07
3210	FARMERS COOPERATIVE	3010-MAY26	7.996 gal Premium @ 5.029	05/31/2026	40.21
3210	FARMERS COOPERATIVE	3010-MAY26	16.556 gal E15 @ 4.11875	05/31/2026	68.19
3210	FARMERS COOPERATIVE	3010-MAY26	26.89 gal E15 @ 4.119	05/31/2026	110.76
3210	FARMERS COOPERATIVE	3010-MAY26	16.685 gal E15 @ 4.11927	05/31/2026	68.73
3210	FARMERS COOPERATIVE	3010-MAY26	12.295 gal Super E89 @ 4.499	05/31/2026	55.32
3210	FARMERS COOPERATIVE	3010-MAY26	3.534 gal Premium @ 4.92	05/31/2026	17.39
3210	FARMERS COOPERATIVE	3010-MAY26	9.829 gal Premium @ 4.92	05/31/2026	48.36
12007	Heritage Landscape Supply Group	0027217166-001	waterfill valve - damaged in flooding	05/27/2026	84.97
12007	Heritage Landscape Supply Group	0027436017-001	4) rotor f/HP & Scott diamond irrigation	06/05/2026	170.92
5100	LAMMEL PLUMBING INC	88011	plumbing supply line f/water line	05/28/2026	17.22
5110	LAMPTON WELDING SUPPLY Co., INC	0001164351	Cylinder rent - Pub. Prop.	05/31/2026	35.16
5160	LARRY'S TIRE AND SERVICE INC.	128238	Labor - 1) tire repair	06/03/2026	20.00
5690	MEAD LUMBER AND RENTAL-BEATRI	13527451	3) treated lumber f/trail bridge south of Pickrell	05/27/2026	43.74
6500	NEBRASKA DEPT. OF REVENUE	34-4153596-MAY26	Chautauqua Park Camping Lodging Tax-May 2026	05/31/2026	240.68
6800	NORTHEAST AUTO	10851	TOW - 07 Sierra	05/19/2026	90.00
11729	Nutrien Ag Solutions	903331886	4) 1-gal plateau f/parking lots	05/29/2026	562.00
11729	Nutrien Ag Solutions	903341136	5) 2.5 gal noventa f/parks	05/29/2026	155.00
11729	Nutrien Ag Solutions	903341136	2.5 gal Liberate f/parks	05/29/2026	90.00
7600	PREMIER CARPET CARE LLC	6602	Labor - water damage @ 1908 Lincoln St	05/28/2026	2,589.57
1073	Rewound Power Motors Sls and Svc Inc	S20988	6) edger blade	05/28/2026	161.64
1073	Rewound Power Motors Sls and Svc Inc	S21045	3) weedeater line	06/10/2026	72.97
12273	Saathoff Solutions	INV368	Labor - Scrap & Paint f/Library North doors	06/08/2026	390.00
12273	Saathoff Solutions	INV368	Supplies - scrap & paint f/Library North doors	06/08/2026	91.00
8260	SAPP BROTHERS	IN5034512	170.0 gal ULSD #2 Dyed Summer Diesel @ 2.70799	05/27/2026	460.36
8260	SAPP BROTHERS	IN5038138	105.5 gal ULSD #2 Dyed Summer Diesel @ 2.70790	06/01/2026	285.69
8260	SAPP BROTHERS	IN5042458	116.0 gal ULSD #2 Dyed Summer Diesel @ 2.70794	06/08/2026	314.13
8370	SCHUSTER'S OUTDOOR AND RV INC.	32824	2) anti-scalp roller kit	06/08/2026	91.98
8370	SCHUSTER'S OUTDOOR AND RV INC.	32824	3) blade	06/08/2026	89.97
12730	SETH AUSTIN RAY	7895	Weed Control, Fertilizer f/Ballfields	05/02/2026	125.00
1050	SHERIDAN INDUSTRIES	15620	Clean @ Indoor Hitting Facility - May 2026	06/01/2026	72.00
8510	SHERWIN-WILLIAMS CO.	7258-5	Paint f/tables	05/29/2026	26.72
8510	SHERWIN-WILLIAMS CO.	7265-0	Paint f/tables	05/29/2026	43.46
12658	SPRING CREEK REPAIR AND FARM S	13978	1) 5-gal power-plus soap	06/04/2026	81.95
12701	SPRINGFIELD ELECTRIC SUPPLY CO	S012026588.001	12) bulb	06/03/2026	34.56
12701	SPRINGFIELD ELECTRIC SUPPLY CO	S012046792.001	fish tape f/electrical	06/09/2026	56.99
12521	SUNNY SMITH	MAY26 2026 - JUN5 2026	Office cleaning f/Aud offices	06/05/2026	405.00
12521	SUNNY SMITH	MAY26 2026 - JUN5 2026	Office cleaning f/BPW offices	06/05/2026	405.00
9320	UHL'S SPORTING GOODS	0011112	2) basketball net f/Riverside	06/07/2026	30.00
9760	Westlake Ace Hardware	10360627	bar oil	06/01/2026	21.59
9760	Westlake Ace Hardware	10360677	wire f/fence repair	06/04/2026	9.89
9760	Westlake Ace Hardware	10360721	channellock plier	06/08/2026	23.39
9760	Westlake Ace Hardware	10360737	2) paper towel	06/09/2026	18.89

Vendor	Vendor Name	Invoice Number	Description	Invoice Date	Net Invoice Amount
10030	WRIGHTSMAN PLBG AND HEAT INC	108668	expansion valve kit f/BPW office ac unit	05/14/2026	322.25
Total PUBLIC PROPERTIES:					26,175.91
<b>PP-WATER PARK</b>					
11323	AQUA-CHEM, INC.	00211565	Chemicals f/ Pool	06/09/2026	172.94
9650	CARDMEMBER SERVICE	0030-FY26	lid, 2) strainer	05/28/2026	705.10
9650	CARDMEMBER SERVICE	0594	5) clarifier	05/29/2026	70.76
9650	CARDMEMBER SERVICE	1052	supplies f/vacuum	05/26/2026	178.77
9650	CARDMEMBER SERVICE	1474-FY26	cleaner, battery, tape, marker	05/23/2026	92.07
9650	CARDMEMBER SERVICE	1474-FY26	toner	05/23/2026	72.92
9650	CARDMEMBER SERVICE	1474-FY26	hotdog buns	05/23/2026	19.90
9650	CARDMEMBER SERVICE	1532-FY26	2) air pump, squeegee pole, nozzle, dawn, bowl brus	05/23/2026	85.63
9650	CARDMEMBER SERVICE	5440-FY26	toner	05/24/2026	53.00
9650	CARDMEMBER SERVICE	5440-FY26	hose, bandage, peroxide, tape	05/24/2026	67.44
9650	CARDMEMBER SERVICE	6034 FY26	3-hole punch, post-it notes, wire	05/27/2026	32.06
9650	CARDMEMBER SERVICE	6434	4) lifeguard rescue tube	05/07/2026	218.45
9650	CARDMEMBER SERVICE	9030	34) tubes, 9) goggles	05/18/2026	201.14
1740	CASH-WA DISTRIBUTING	15122029	concessions	05/29/2026	1,100.30
1740	CASH-WA DISTRIBUTING	15125172	concessions	06/02/2026	1,913.94
1740	CASH-WA DISTRIBUTING	15129285	concessions	06/05/2026	1,047.23
1740	CASH-WA DISTRIBUTING	15132380	concessions	06/09/2026	1,021.87
1740	CASH-WA DISTRIBUTING	D15127903	concessions	06/04/2026	29.74
4090	HAWKINS INC.	7439702	pool chemicals	05/28/2026	1,418.46
7280	PEPSI COLA OF LINCOLN	1100427138	concessions	06/04/2026	178.65
Total PP-WATER PARK:					8,680.37
<b>LIBRARY</b>					
9660	CARDMEMBER SERVICE	MAY 2026	Parade of Horrible	06/01/2026	27.00
9660	CARDMEMBER SERVICE	MAY 2026	2) She Knows All the Names	06/01/2026	31.98
9660	CARDMEMBER SERVICE	MAY 2026	2) 50-pk iron-on heat transfer paper	06/01/2026	121.98
9660	CARDMEMBER SERVICE	MAY 2026	Ultimate Guide to Thriving with Adult Autism	06/01/2026	17.98
9660	CARDMEMBER SERVICE	MAY 2026	Yellow-Tail Moth	06/01/2026	12.99
9660	CARDMEMBER SERVICE	MAY 2026	To His New Wife	06/01/2026	9.99
9660	CARDMEMBER SERVICE	MAY 2026	Forgotten Kill	06/01/2026	12.99
9660	CARDMEMBER SERVICE	MAY 2026	Cabin at The End of the Train	06/01/2026	14.53
9660	CARDMEMBER SERVICE	MAY 2026	Purple State	06/01/2026	20.98
9660	CARDMEMBER SERVICE	MAY 2026	Wayfaring Widow	06/01/2026	14.99
9660	CARDMEMBER SERVICE	MAY 2026	Fall Kill	06/01/2026	10.99
9660	CARDMEMBER SERVICE	MAY 2026	2) Dark Kill	06/01/2026	23.98
9660	CARDMEMBER SERVICE	MAY 2026	Autistic's Guide to Self-Discovery	06/01/2026	17.66
9660	CARDMEMBER SERVICE	MAY 2026	Summer's Kill	06/01/2026	10.99
9660	CARDMEMBER SERVICE	MAY 2026	Spring Kill	06/01/2026	10.99
9660	CARDMEMBER SERVICE	MAY 2026	Winter's Kill	06/01/2026	12.99
9660	CARDMEMBER SERVICE	MAY 2026	Chasing the Clouds Away	06/01/2026	17.57
9660	CARDMEMBER SERVICE	MAY 2026	Calamity Club	06/01/2026	24.44
9660	CARDMEMBER SERVICE	MAY 2026	Case for America	06/01/2026	24.78
9660	CARDMEMBER SERVICE	MAY 2026	Murder in Hollywood	06/01/2026	20.57
9660	CARDMEMBER SERVICE	MAY 2026	Oleander Sword	06/01/2026	15.99
9660	CARDMEMBER SERVICE	MAY 2026	Nebraska Bucket List 2026	06/01/2026	16.99
9660	CARDMEMBER SERVICE	MAY 2026	26 Beauties	06/01/2026	17.06
9660	CARDMEMBER SERVICE	MAY 2026	Kill for a Million	06/01/2026	27.83
9660	CARDMEMBER SERVICE	MAY 2026	Things We Never Say	06/01/2026	25.48
9660	CARDMEMBER SERVICE	MAY 2026	Killed to Order	06/01/2026	29.21
9660	CARDMEMBER SERVICE	MAY 2026	Walk	06/01/2026	27.96
9660	CARDMEMBER SERVICE	MAY 2026	Complete Route 66 Travel Guide	06/01/2026	12.99

Vendor	Vendor Name	Invoice Number	Description	Invoice Date	Net Invoice Amount
9660	CARDMEMBER SERVICE	MAY 2026	Our Perfect Storm	06/01/2026	17.55
9660	CARDMEMBER SERVICE	MAY 2026	Fourth Option	06/01/2026	21.00
9660	CARDMEMBER SERVICE	MAY 2026	175 Best Air Fryer Recipes	06/01/2026	16.93
9660	CARDMEMBER SERVICE	MAY 2026	Day by Day - The Rise, DVD	06/01/2026	32.45
9660	CARDMEMBER SERVICE	MAY 2026	shipping	06/01/2026	3.57
9660	CARDMEMBER SERVICE	MAY 2026	One Wrong Step	06/01/2026	16.49
9660	CARDMEMBER SERVICE	MAY 2026	Mystery of Locked Rooms	06/01/2026	6.77
9660	CARDMEMBER SERVICE	MAY 2026	Bye Forever, I Guess	06/01/2026	14.37
9660	CARDMEMBER SERVICE	MAY 2026	Breaker Boys; How a Photograph Helped end Child L	06/01/2026	9.09
9660	CARDMEMBER SERVICE	MAY 2026	Ballpark Mysteries, 1-4	06/01/2026	22.02
9660	CARDMEMBER SERVICE	MAY 2026	House with No Keys	06/01/2026	15.83
9660	CARDMEMBER SERVICE	MAY 2026	Not Quite a Ghost	06/01/2026	7.91
9660	CARDMEMBER SERVICE	MAY 2026	Elephant in The Room	06/01/2026	15.10
9660	CARDMEMBER SERVICE	MAY 2026	Win or Lose	06/01/2026	12.91
9660	CARDMEMBER SERVICE	MAY 2026	Paper Girl of Paris	06/01/2026	12.53
9660	CARDMEMBER SERVICE	MAY 2026	Credit - return Summoned to the Wilds	06/01/2026	17.70-
9660	CARDMEMBER SERVICE	MAY 2026	Bitter Queen	06/01/2026	14.24
9660	CARDMEMBER SERVICE	MAY 2026	Little Bird	06/01/2026	14.24
9660	CARDMEMBER SERVICE	MAY 2026	Into The Golden Era	06/01/2026	16.98
9660	CARDMEMBER SERVICE	MAY 2026	Wild Card	06/01/2026	15.24
9660	CARDMEMBER SERVICE	MAY 2026	Last Sweet Mile	06/01/2026	16.99
9660	CARDMEMBER SERVICE	MAY 2026	Black Jack	06/01/2026	14.24
9660	CARDMEMBER SERVICE	MAY 2026	Book Woman's Daughter	06/01/2026	35.99
9660	CARDMEMBER SERVICE	MAY 2026	Credit - return A Dark Kill	06/01/2026	11.99-
9660	CARDMEMBER SERVICE	MAY 2026	Silver Elite	06/01/2026	14.98
9660	CARDMEMBER SERVICE	MAY 2026	House of Leaves	06/01/2026	22.00
9660	CARDMEMBER SERVICE	MAY 2026	Dogs, Boys, and Other Things I've Cried About	06/01/2026	19.60
9660	CARDMEMBER SERVICE	MAY 2026	Broken Dove	06/01/2026	23.12
9660	CARDMEMBER SERVICE	MAY 2026	Fury Bound	06/01/2026	22.40
9660	CARDMEMBER SERVICE	MAY 2026	True Crime	06/01/2026	21.12
9660	CARDMEMBER SERVICE	MAY 2026	Bright Years	06/01/2026	16.78
9660	CARDMEMBER SERVICE	MAY 2026	Wakara's America	06/01/2026	25.60
9660	CARDMEMBER SERVICE	MAY 2026	Dire Bound	06/01/2026	11.90
9660	CARDMEMBER SERVICE	MAY 2026	Tituba of Salem Village	06/01/2026	7.85
9660	CARDMEMBER SERVICE	MAY 2026	Lady Knight	06/01/2026	6.66
9660	CARDMEMBER SERVICE	MAY 2026	Page	06/01/2026	12.11
9660	CARDMEMBER SERVICE	MAY 2026	Squire	06/01/2026	13.04
9660	CARDMEMBER SERVICE	MAY 2026	Monster in The Hollows	06/01/2026	6.52
9660	CARDMEMBER SERVICE	MAY 2026	North! Or Be Eaten	06/01/2026	7.59
9660	CARDMEMBER SERVICE	MAY 2026	Warden and The Wolf King	06/01/2026	7.15
9660	CARDMEMBER SERVICE	MAY 2026	Seven Thrilling Stories from the World of Aerwiar	06/01/2026	8.79
9660	CARDMEMBER SERVICE	MAY 2026	Game of Thrones Season 1, DVD	06/01/2026	11.63
9660	CARDMEMBER SERVICE	MAY 2026	Mighty Neighborly	06/01/2026	16.00
9660	CARDMEMBER SERVICE	MAY 2026	There are Rivers in the Sky	06/01/2026	13.87
9660	CARDMEMBER SERVICE	MAY 2026	Coyote America	06/01/2026	12.69
9660	CARDMEMBER SERVICE	MAY 2026	Letter to the Romans	06/01/2026	65.76
9660	CARDMEMBER SERVICE	MAY 2026	Bared to You	06/01/2026	13.76
9660	CARDMEMBER SERVICE	MAY 2026	Darkhorse	06/01/2026	22.98
9660	CARDMEMBER SERVICE	MAY 2026	Hooked	06/01/2026	15.88
9660	CARDMEMBER SERVICE	MAY 2026	Haunting Adeline	06/01/2026	14.98
9660	CARDMEMBER SERVICE	MAY 2026	WILDLIFE ENCOUNTERS - Summer Reading Progr	06/01/2026	495.00
9660	CARDMEMBER SERVICE	MAY 2026	7) 60" garden bench, sandstone	06/01/2026	5,368.70
9660	CARDMEMBER SERVICE	MAY 2026	Credit - return She Knows all the Names	06/01/2026	15.99-
9660	CARDMEMBER SERVICE	MAY 2026	Credit - return Not Quite a Ghost	06/01/2026	7.91-
9660	CARDMEMBER SERVICE	MAY 2026	The Real Yellow Pages - formerly vival monthly fee	06/01/2026	62.10
9660	CARDMEMBER SERVICE	MAY 2026	Shipping	06/01/2026	4.62-
9660	CARDMEMBER SERVICE	MAY 2026	From Blood and Ash	06/01/2026	9.96

Vendor	Vendor Name	Invoice Number	Description	Invoice Date	Net Invoice Amount
9660	CARDMEMBER SERVICE	MAY 2026	Once There was a Bull	06/01/2026	6.94
9660	CARDMEMBER SERVICE	MAY 2026	Thirst	06/01/2026	8.35
9660	CARDMEMBER SERVICE	MAY 2026	Touch and Feel: Farm	06/01/2026	4.07
9660	CARDMEMBER SERVICE	MAY 2026	My Encyclopedia of Very Important Dinosaurs	06/01/2026	18.79
2060	CITY SELF INSURED HEALTH PLAN	JUNE 2026	Lib Health Insurance Funding	06/01/2026	8,400.00
2080	CITY TREASURER	JUN26-IT GENERAL	IT Services	06/01/2026	579.00
12617	FOX, MORGAN	ED ASSIST - SPRING 202	Ed Assistance - Spring 2026	05/27/2026	2,564.43
11273	History Nebraska	RENEWAL 2026	Renew subscription	05/13/2026	35.00
12283	Lucas Holdings, LLC	73390	Beatrice Public Library - patron cards	06/03/2026	619.70
12137	Unite Private Networks LLC	SI-26-031831	Education Wide Area Network Monthly fee w/ E-Rate	06/01/2026	365.00
12137	Unite Private Networks LLC	SI-26-031831	Federal Regulatory Recovery	06/01/2026	1.52
12137	Unite Private Networks LLC	SI-26-031831	NE Universal Service	06/01/2026	25.48
12137	Unite Private Networks LLC	SI-26-031831	E-Rate FRN 2599014260 (monthly rate) - June	06/01/2026	313.60
Total LIBRARY:					19,613.31
Total GENERAL FUND:					334,633.79

**STREET FUND**

**STREET FUND**

840	BEATRICE AREA SOLID WASTE AGNC	225-MAY26	#1109-5.0IX12 (PD Firing range)	05/31/2026	60.00
840	BEATRICE AREA SOLID WASTE AGNC	225-MAY26	#1119 -5.0Tx12 (PD)	05/31/2026	60.00
840	BEATRICE AREA SOLID WASTE AGNC	225-MAY26	#1133-5.0Tx12.00(PD)	05/31/2026	60.00
840	BEATRICE AREA SOLID WASTE AGNC	225-MAY26	#1131-5.82Tx52.00(PD)	05/31/2026	302.64
840	BEATRICE AREA SOLID WASTE AGNC	225-MAY26	#1132-5.82x52.00(PD)	05/31/2026	302.64
840	BEATRICE AREA SOLID WASTE AGNC	225-MAY26	#1134-5.82Tx52.00(PD)	05/31/2026	302.64
840	BEATRICE AREA SOLID WASTE AGNC	225-MAY26	#1135-5.82Tx52.00(PD)	05/31/2026	302.64
840	BEATRICE AREA SOLID WASTE AGNC	225-MAY26	#1147-3.34T x52.00(PD)	05/31/2026	173.68
840	BEATRICE AREA SOLID WASTE AGNC	225-MAY26	#1151-5.65T x52.00(PD)	05/31/2026	293.80
840	BEATRICE AREA SOLID WASTE AGNC	225-MAY26	#1157-4.08Tx52.00 (PD)	05/31/2026	212.16
840	BEATRICE AREA SOLID WASTE AGNC	225-MAY26	#1186-5.Tx12.00(PD)	05/31/2026	60.00
840	BEATRICE AREA SOLID WASTE AGNC	225-MAY26	#1196-5.0T x 12.00(PD)	05/31/2026	60.00
840	BEATRICE AREA SOLID WASTE AGNC	225-MAY26	#1185-5.02T x52.00(PD)	05/31/2026	261.04
840	BEATRICE AREA SOLID WASTE AGNC	225-MAY26	#1190-2.44T x52.00 (PD)	05/31/2026	126.88
980	BEATRICE IRON AND METAL CO	114492	1)Seaform@10.45(cust#1074)	06/04/2026	10.45
980	BEATRICE IRON AND METAL CO	114492	1)Green Nitrile@28.59(cust#1074)	06/04/2026	28.59
980	BEATRICE IRON AND METAL CO	114492	1)XXL Thickster@11.49(cust#1074)	06/04/2026	11.49
980	BEATRICE IRON AND METAL CO	114492	12)brake clean@3.99(cust#1074)	06/04/2026	47.88
1350	BOARD OF PUBLIC WORKS	1131.01-JUN26	Share building repair fund	06/01/2026	250.00
1350	BOARD OF PUBLIC WORKS	1146.40-STFUEL-MAY26	873.83 gal Diesel @ 2.708	06/01/2026	2,366.34
1350	BOARD OF PUBLIC WORKS	1146.40-STFUEL-MAY26	336.35 gal Unleaded @ 2.615	06/01/2026	879.55
1350	BOARD OF PUBLIC WORKS	1456.00-JUN26	Engineering Services	06/01/2026	5,612.00
12095	Bomgaars Supply Inc	592691	1)Pump,sprayer@119.99	05/29/2026	119.99
12095	Bomgaars Supply Inc	595729	2)Barb, Hose Straight@1.99	06/05/2026	3.98
12095	Bomgaars Supply Inc	595729	1)Valve, bAll@14.99	06/05/2026	14.99
12095	Bomgaars Supply Inc	595729	2)Hose Clamp @1.99	06/05/2026	3.98
12095	Bomgaars Supply Inc	595772	1)Elbow , Hose barb @2.29	06/05/2026	2.29
2060	CITY SELF INSURED HEALTH PLAN	JUN26-STREET	Street Dept Health Insurance Funding	06/01/2026	25,200.00
2080	CITY TREASURER	ATTY-JUN26	Attorney Services-Street	06/01/2026	827.00
2080	CITY TREASURER	GM-JUN26	general Manager Sly-Street	06/01/2026	1,776.00
2080	CITY TREASURER	ST IT-JUN26	IT Fund Monthly Obligation-Street	06/01/2026	7,192.00
2460	CORNHUSKER STATE INDUSTRIES	1526736	34)9x24 street marker@13.10	06/05/2026	445.40
2460	CORNHUSKER STATE INDUSTRIES	1526736	26)9x30 street marker@16.40	06/05/2026	426.40
2460	CORNHUSKER STATE INDUSTRIES	1526736	6)9x24 Street Marker@22.95	06/05/2026	137.70
2460	CORNHUSKER STATE INDUSTRIES	1526736	10)12x18 No Parking Here to corner@10.40	06/05/2026	104.00
2460	CORNHUSKER STATE INDUSTRIES	1526739	12)12x36 Object Marker, Left @30.65	06/05/2026	367.80
2460	CORNHUSKER STATE INDUSTRIES	1526739	12)12x36 Object Marker Right@30.65	06/05/2026	367.80

Vendor	Vendor Name	Invoice Number	Description	Invoice Date	Net Invoice Amount
3210	FARMERS COOPERATIVE	2265-MAY26	Tire Repair	05/31/2026	65.00
3210	FARMERS COOPERATIVE	2265-MAY26	1)11R22.5 Samson @288.00	05/31/2026	288.00
3210	FARMERS COOPERATIVE	2265-MAY26	Tire Disposal	05/31/2026	8.00
3210	FARMERS COOPERATIVE	2265-MAY26	Tire Tax	05/31/2026	1.00
3210	FARMERS COOPERATIVE	2265-MAY26	1)11R22.5 Samson@288	05/31/2026	288.00
3210	FARMERS COOPERATIVE	2265-MAY26	Tire Disposal	05/31/2026	8.00
3210	FARMERS COOPERATIVE	2265-MAY26	Tire Tax	05/31/2026	1.00
3210	FARMERS COOPERATIVE	2265-MAY26	Tire Repair	05/31/2026	40.00
3210	FARMERS COOPERATIVE	2265-MAY26	2)25-10R12/10 Airloc Palad@149.99	05/31/2026	299.98
3210	FARMERS COOPERATIVE	2265-MAY26	Tire Tax	05/31/2026	2.00
3210	FARMERS COOPERATIVE	2265-MAY26	29.6690 dyed Diesel	05/31/2026	130.42
3210	FARMERS COOPERATIVE	2265-MAY26	43.1120 Dyed Diesel	05/31/2026	189.52
12007	Heritage Landscape Supply Group	0027433523-002	irrigation supplies f/Ella Street	06/05/2026	2,205.72
11734	Ideus Tree Service	890370	Remove Maple Tree SWC 7th/Jackson	06/03/2026	2,500.00
12591	Interstate Power Systems, Inc	R023067273 01	Labor-Unit wont start	06/03/2026	400.00
12591	Interstate Power Systems, Inc	R023067273 01	Service-DTS	06/03/2026	45.00
12591	Interstate Power Systems, Inc	R023067273 01	Shop supplies	06/03/2026	45.00
4670	JEO CONSULTING GROUP INC	174192	Construction Administration & Staking f/Heritage Heig	05/28/2026	660.00
4670	JEO CONSULTING GROUP INC	174192	Construction Observation & Material Testing f/Heritag	05/28/2026	3,334.21
4670	JEO CONSULTING GROUP INC	174193	Construction Administration & Staking f/Corral Crossi	05/28/2026	66.25
4670	JEO CONSULTING GROUP INC	174193	Construction Observation & Material Testing f/Corral	05/28/2026	1,310.00
5110	LAMPTON WELDING SUPPLY Co., INC	0001164351	Cylinder rent - Street	05/31/2026	23.43
12532	Martin Resource Management	1832196	120ga) CSS-1H Bulk Gallon(Tac Oil)@2.75	06/08/2026	330.00
5690	MEAD LUMBER AND RENTAL-BEATRI	13532254	1)200ft Roll starter cord@60.00	05/28/2026	60.00
5690	MEAD LUMBER AND RENTAL-BEATRI	13532254	Freight	05/28/2026	28.00
11729	Nutrien Ag Solutions	903332354	1)Remedy 4x1 gal @72.50	05/29/2026	72.50
7060	O'REILLY AUTO PARTS	0749-156572	2)Wire MF Conn@7.99	05/29/2026	15.98
7060	O'REILLY AUTO PARTS	0749-156572	1)Butt Splice @5.44	05/29/2026	5.44
7060	O'REILLY AUTO PARTS	0749-156572	1)But Splice@27.99	05/29/2026	27.99
7060	O'REILLY AUTO PARTS	0749-157939	4)Gear Lube@10.50	06/04/2026	42.00
7060	O'REILLY AUTO PARTS	0749-158929	3)1qtMotorOil@8.99	06/08/2026	26.97
7060	O'REILLY AUTO PARTS	0749-159060	3)1qtMotorOil@8.99--returned	06/09/2026	26.97-
7060	O'REILLY AUTO PARTS	0749-159060	1)Oil Filter @18.99	06/09/2026	18.99
7060	O'REILLY AUTO PARTS	0749-159060	3)1qtMotorOil@7.99	06/09/2026	23.97
7230	PAVERS INC.	112442	28.67tn) Hot Mix Asphalt 5-28-26@80.00	06/01/2026	2,293.60
12243	Premier Mower & PowerSports LLC	0852493	2)Blade@32.22	06/02/2026	64.44
12243	Premier Mower & PowerSports LLC	0852493	1)Blade@31.93	06/02/2026	31.93
12243	Premier Mower & PowerSports LLC	0857722	3)BLADE @32.22	06/08/2026	96.66
12393	Rollins Inc	296536471	Pest Control Standard f/Street -MaY26	05/28/2026	75.27
8510	SHERWIN-WILLIAMS CO.	7392-2	1)Packgsaverlube 11.89-discount	06/04/2026	10.46
8510	SHERWIN-WILLIAMS CO.	7392-2	38)5gal Strainer@2.99-discount	06/04/2026	79.53
9260	TRACTOR SUPPLY	485228	1)Elbow Male @2.39	05/29/2026	2.39
9260	TRACTOR SUPPLY	769119	2)DEWALT 2PK FLAP DISC@14.99	06/03/2026	29.98
11418	VISA	20081-MAY26-S	30) hi-vis t shirt	06/02/2026	264.85
11418	VISA	20081-MAY26-S	angle grinder	06/02/2026	39.99
11418	VISA	20081-MAY26-S	transfer pump	06/02/2026	89.99
11418	VISA	20081-MAY26-S	20V replacement battery	06/02/2026	79.99
11418	VISA	20081-MAY26-S	rechargeable flashlight	06/02/2026	22.99
11418	VISA	20081-MAY26-S	10) safety shirt	06/02/2026	204.95
11418	VISA	20081-MAY26-S	replacement blade backing flange	06/02/2026	14.97

Total STREET FUND: 64,711.14

Total STREET FUND: 64,711.14

AIRPORT FUND

Vendor	Vendor Name	Invoice Number	Description	Invoice Date	Net Invoice Amount
<b>AIRPORT-GENERAL</b>					
1350	BOARD OF PUBLIC WORKS	1417.50-AIRPORT.MAY26	90.46 gal Diesel @ 2.708	06/01/2026	244.97
9650	CARDMEMBER SERVICE	1152-FY26	Registration f/4 States Airport Conf - Schmitt	05/08/2026	350.00
9650	CARDMEMBER SERVICE	3806	1-lb) heavy duty grease	05/01/2026	5.99
9650	CARDMEMBER SERVICE	6589-FY26	v-belt	05/22/2026	18.32
9650	CARDMEMBER SERVICE	6862-FY26	gasket	05/12/2026	26.97
9650	CARDMEMBER SERVICE	7687-FY26	3) safety shirt, long sleeve lg	05/15/2026	104.07
9650	CARDMEMBER SERVICE	7687-FY26	1) safety shirt, long sleeve 2xl	05/15/2026	34.69
9650	CARDMEMBER SERVICE	7687-FY26	3) safety shirt, long sleeve 3xl	05/15/2026	104.07
9650	CARDMEMBER SERVICE	7687-FY26	Shipping	05/15/2026	43.21
9650	CARDMEMBER SERVICE	8993-FY26	3-pc glow plug	05/15/2026	36.00
9650	CARDMEMBER SERVICE	9315	clutch/brake f/mower	05/20/2026	320.36
9650	CARDMEMBER SERVICE	9766	direcTV monthly subscription	05/10/2026	49.99
2060	CITY SELF INSURED HEALTH PLAN	AIRPORT-JUN26	Airport Health Insurance Funding	06/01/2026	8,400.00
2080	CITY TREASURER	JUN26-IT AIRPORT	IT Services	06/01/2026	242.00
2690	DAWGS SPORTS SPECIALTIES	11277	7) logo on pocket	05/27/2026	56.00
2690	DAWGS SPORTS SPECIALTIES	11277	7) "airport" on back	05/27/2026	35.00
5690	MEAD LUMBER AND RENTAL-BEATRI	13556690	bulk fasteners	06/02/2026	.69
9850	UNIFIRST CORPORATION	1910118347	Launder mats, shop towel	06/01/2026	95.49
Total AIRPORT-GENERAL:					10,167.82
<b>AIRPORT-CAPITAL IMPROVEMENTS</b>					
12684	AHRS CONSTRUCTION, INC.	PMT 2	Construct new T-Hangar, Upgrade Taxilanes, Reconst	06/08/2026	31,553.60
1080	ALFRED BENESCH AND COMPANY	15E-PROJ24	Construction Phase f/T-Hangar, upgrade Taxilanes &	06/08/2026	19,156.55
1080	ALFRED BENESCH AND COMPANY	15E-PROJ24	Material Testing f/T-Hangar, upgrade Taxilanes & reco	06/08/2026	3,552.50
1080	ALFRED BENESCH AND COMPANY	37E-PROJ21	Reconstruct Taxiway C & Apron	06/08/2026	2,811.70
1080	ALFRED BENESCH AND COMPANY	8E-NAVAID	Design f/Grant No: 3-31-0009-025, Navaid Upgrades	06/08/2026	2,430.53
1080	ALFRED BENESCH AND COMPANY	8E-NAVAID	Bidding f/Grant No: 3-31-0009-025, Navaid Upgrades	06/08/2026	166.62
1080	ALFRED BENESCH AND COMPANY	8E-NAVAID	Construction f/Grant No: 3-31-0009-025, Navaid Upgr	06/08/2026	2,050.79
Total AIRPORT-CAPITAL IMPROVEMENTS:					61,722.29
Total AIRPORT FUND:					71,890.11
<b>BEATRICE AREA SOLID WASTE AGNC</b>					
<b>BASWA</b>					
840	BEATRICE AREA SOLID WASTE AGNC	BAD DEBT-APR26	AR 386 - write-off - send to CA	04/01/2026	196.04
980	BEATRICE IRON AND METAL CO	114290	foaming coil cleaner	05/27/2026	15.69
980	BEATRICE IRON AND METAL CO	114290	fuel/water separator filter f/Brown Bear	05/27/2026	21.87
980	BEATRICE IRON AND METAL CO	114386	2) air filter f/Brown Bear & loader	05/29/2026	253.53
980	BEATRICE IRON AND METAL CO	114475	1) filter f/spray truck	06/03/2026	40.29
980	BEATRICE IRON AND METAL CO	114475	2) 1-qt oil f/spray truck	06/03/2026	13.24
980	BEATRICE IRON AND METAL CO	114476	2) filter f/spray truck	06/03/2026	16.30
3049	Beatrice Sand and Gravel	S1 215844	61.29 tn) 2" - 3" screen rock	05/29/2026	1,823.98
3049	Beatrice Sand and Gravel	S1 215844	150.96 tn) 2 - 3" crusher run	05/29/2026	3,841.91
3049	Beatrice Sand and Gravel	S1 215844	16.9 tn) 3/4" screen rock	05/29/2026	520.35
3049	Beatrice Sand and Gravel	S1 215844	17.3 tn) 1" screen rock	05/29/2026	532.67
3049	Beatrice Sand and Gravel	S1 216061	26.75 tn) 1" screen rock	06/08/2026	829.51
1350	BOARD OF PUBLIC WORKS	#1456.00-JUN26	Engineering Services	06/01/2026	1,104.00
1350	BOARD OF PUBLIC WORKS	40154911-JUN26	Security Lights f/Compost	06/05/2026	13.89
12095	Bomgaars Supply Inc	592712	2) tow chain	05/29/2026	139.98
12095	Bomgaars Supply Inc	597017	2) p'Blaster, 3) pipe plug	06/08/2026	20.95
12095	Bomgaars Supply Inc	597017	10) 2-cycle oil	06/08/2026	22.90
1700	CARPENTER PAPER CO.	423573	2-cs) toilet paper	06/04/2026	193.99
2060	CITY SELF INSURED HEALTH PLAN	BASWA-JUN26	BASWA Health Insurance Funding	06/01/2026	14,000.00
2080	CITY TREASURER	JUN26-IT BASWA	IT Services	06/01/2026	1,913.00

Vendor	Vendor Name	Invoice Number	Description	Invoice Date	Net Invoice Amount
2080	CITY TREASURER	JUNE 2026	Legal Services	06/01/2026	460.00
2080	CITY TREASURER	JUNE 2026	Accounting Services	06/01/2026	3,201.00
2080	CITY TREASURER	JUNE 2026	Landfill Manager Salary	06/01/2026	1,594.00
2080	CITY TREASURER	JUNE 2026	Lease Payment	06/01/2026	4,000.00
2080	CITY TREASURER	JUNE 2026	Management Contract	06/01/2026	2,577.00
3210	FARMERS COOPERATIVE	3010-MAY26	Labor - 1) tire repair	05/31/2026	25.00
3210	FARMERS COOPERATIVE	3010-MAY26	50.518 gal E15 @ 3.979	05/31/2026	201.01
3210	FARMERS COOPERATIVE	44577-MAY26	5.0 gal gunslinger herbicide @ 37.50	05/31/2026	187.50
3210	FARMERS COOPERATIVE	44577-MAY26	5.0 gal gen glyphosate herbicide @ 22.00	05/31/2026	110.00
12592	GENESIS CONTRACTING GROUP LLC	PMT 14 - FINAL	Site Entrance Facility	06/03/2026	35,651.95
12592	GENESIS CONTRACTING GROUP LLC	PMT 14 - FINAL	Change Order #1 - cost adj, time extension	06/03/2026	4,917.22
12688	Global Payments	6921-MAY26	Monthly credit card fees	05/31/2026	520.46
5690	MEAD LUMBER AND RENTAL-BEATRI	13522107	2) marking flag, red	05/25/2026	18.22
12549	MES I ACQUISITION INC	IN2514535	Rent - Landtec GEM2000	05/22/2026	362.00
5810	MIDWEST LABORATORIES INC	1289397	Soil sampling f/ Compost site	06/02/2026	228.00
6820	NORRIS PUBLIC POWER DISTRICT	304097500-MAY26	Energy Charge f/LF	06/05/2026	700.00
6820	NORRIS PUBLIC POWER DISTRICT	304098500-MAY26	Electric charge f/Compost Site	06/05/2026	215.20
6820	NORRIS PUBLIC POWER DISTRICT	312515400-MAY26	Electric charge f/W Locust Rd Lift Station	06/05/2026	202.69
6820	NORRIS PUBLIC POWER DISTRICT	312515800-MAY26	Electric charge f/W Locust Rd Leachate Pond	06/05/2026	35.00
6820	NORRIS PUBLIC POWER DISTRICT	312516000-MAY26	Electric charge f/W Locust Admin/Equipment Building	06/05/2026	330.80
7060	O'REILLY AUTO PARTS	0749-155002	3) oil filter f/dump truck	05/22/2026	67.38
7060	O'REILLY AUTO PARTS	0749-155002	20) moly grease	05/22/2026	133.80
7060	O'REILLY AUTO PARTS	0749-156506	1) oil filter	05/29/2026	16.69
7060	O'REILLY AUTO PARTS	0749-157710	1) oil filter	06/03/2026	28.89
7060	O'REILLY AUTO PARTS	0749-158883	12) brake cleaner	06/08/2026	41.88
7060	O'REILLY AUTO PARTS	0749-158883	12) carb cleaner	06/08/2026	39.48
12393	Rollins Inc	296536473	Pest Control Standard - May 2026	05/28/2026	75.00
8260	SAPP BROTHERS	IN5011290	68.1 gal DEF @ 2.304646	04/24/2026	156.95
8260	SAPP BROTHERS	IN5011290	115.0 bulk 15W40 @ 16.25	04/24/2026	1,868.75
8260	SAPP BROTHERS	IN5011290	115.0 bulk Tractor Fluid @ 14.25	04/24/2026	1,638.75
11678	Truck Center Companies	XA108220339.01	dipstick f/dump truck	05/29/2026	138.88
11450	TSYS Merchant Solutions	11573762-MAY26	monthly credit card fees	05/31/2026	10.89
11418	VISA	20081-MAY26-B	2) grabber reacher tool	06/02/2026	21.99
11418	VISA	20081-MAY26-B	2) safety fence w/stakes	06/02/2026	113.98
11418	VISA	20081-MAY26-B	2-pk "SLOW" sign	06/02/2026	16.99
11418	VISA	20081-MAY26-B	clothes rack f/jeans	06/02/2026	20.99
9730	WALKER UNIFORM RENTAL	1470756	Uniform Service	05/07/2026	42.22
9730	WALKER UNIFORM RENTAL	1474495	Uniform Service	05/28/2026	42.22
9730	WALKER UNIFORM RENTAL	1475774	Uniform Service	06/04/2026	42.22
Total BASWA:					85,569.09
Total BEATRICE AREA SOLID WASTE AGNC:					85,569.09
<b>CAPITAL IMP FUND</b>					
<b>CAPITAL IMPROVEMENTS-GENERAL</b>					
12352	ASSA ABLOY ENTRANCE SYSTEMS U	CSI 112073	Automatic Sliding Glass f/Senior Center	05/19/2026	14,327.00
1540	BUILDING TECH INC	5351	Concrete f/Heritage Heights playground	05/26/2026	3,660.98
12433	SportsMan LC	1620	HP Sponsorship commission - JEO (Outfield Signage)	04/06/2026	375.00
12433	SportsMan LC	1620	HP Sponsorship commission - Runza (Scoreboard)	04/06/2026	900.00
Total CAPITAL IMPROVEMENTS-GENERAL:					19,262.98
Total CAPITAL IMP FUND:					19,262.98

911 SURCHARGE FUND

Vendor	Vendor Name	Invoice Number	Description	Invoice Date	Net Invoice Amount
2080	CITY TREASURER	E911 WIRELESS-2026	E911 Wireless Transfer - 2026	06/08/2026	86,154.53
Total :					86,154.53
Total 911 SURCHARGE FUND:					86,154.53
<b>INFO TECH SERV FUND</b>					
<b>INFO TECH SERVICES</b>					
12056	ALL COPY PRODUCTS	42228793	Copier Rental	06/10/2026	389.54
12056	ALL COPY PRODUCTS	42228793	Copy usage - 5/5 - 6/4	06/10/2026	56.60
9650	CARDMEMBER SERVICE	0579	apple TV 4K (3rd generation)	05/07/2026	147.28
9650	CARDMEMBER SERVICE	1337	2) Adobe	05/19/2026	67.54
9650	CARDMEMBER SERVICE	2191-FY26	totalMount Pro f/Apple TV 4K	05/08/2026	42.95
9650	CARDMEMBER SERVICE	3131	100) UniFi Hosting	05/16/2026	29.00
9650	CARDMEMBER SERVICE	3221	1) Cove Data Protection - Apr26	05/17/2026	11.00
9650	CARDMEMBER SERVICE	3501-FY26	iPhone case	05/11/2026	31.57
9650	CARDMEMBER SERVICE	3537-FY26	DriveHQ - Cloud IT Service	05/20/2026	282.58
9650	CARDMEMBER SERVICE	4972-FY26	credit - 3) Microsoft	05/02/2026	4.29
9650	CARDMEMBER SERVICE	5337	4) Seagate 2-TB Hard Drive	05/27/2026	511.70
9650	CARDMEMBER SERVICE	6478	1) Microsoft, May26	05/18/2026	38.70
9650	CARDMEMBER SERVICE	9806	Seagate 1TB Hard Drive	05/04/2026	171.69
9650	CARDMEMBER SERVICE	9890	Linode - Apr26	05/01/2026	60.00
11714	Caselle, Inc.	INV-18889	Cloud Hosting - June 2026	05/01/2026	903.00
11714	Caselle, Inc.	INV-18889	Maintenance & Support - June 2026	05/01/2026	3,937.00
11714	Caselle, Inc.	INV-20537	Cloud Hosting - 7/1/2026 - 6/30/2027	06/03/2026	11,919.60
11714	Caselle, Inc.	INV-20537	Maintenance & Support - 7/1/2026 - 6/30/2027	06/03/2026	50,318.40
1034	CHARTER COMMUNICATIONS	156544301060726	Cable charges/500 N Commerce - Jun26	06/07/2026	60.02
1034	CHARTER COMMUNICATIONS	176176901060726	Internet f/AMI & Sub 8 - Jun26	06/07/2026	139.98
1034	CHARTER COMMUNICATIONS	176178901052126	Cable services/Police - May26	05/21/2026	37.53
1034	CHARTER COMMUNICATIONS	176179201060726	Internet f/AMI & Sub 5 - Jun26	06/07/2026	129.98
2060	CITY SELF INSURED HEALTH PLAN	IT - OCT25-JUN26	Info Tech Health Insurance Funding - Oct 2025 - Jun	06/01/2026	100,800.00
12067	Diode Communications	(SEC)000-0123-JUN26	64) Open Path	06/01/2026	425.00
12067	Diode Communications	(SEC)000-0123-JUN26	6) Rhombus	06/01/2026	99.48
4300	HOMETOWN LEASING	518017326126	51801732 Lease f/multiple - Jun26	06/02/2026	1,802.66
12675	INTERMEDIA.NET INC	2606060482	Phone Service	06/01/2026	150.12
12675	INTERMEDIA.NET INC	2606060482	Phone Service	06/01/2026	90.07
12675	INTERMEDIA.NET INC	2606060482	Phone Service	06/01/2026	60.05
2076	U.S. Cellular	0813661138	Electric - Cell Phone Charges	06/06/2026	207.86
2076	U.S. Cellular	0813661138	Electric - Tablet Data Charges	06/06/2026	143.60
2076	U.S. Cellular	0813661138	Water - Cell Phone Charges	06/06/2026	185.38
2076	U.S. Cellular	0813661138	Water - Tablet Data Charges	06/06/2026	286.30
2076	U.S. Cellular	0813661138	WPC - Cell Phone Charges	06/06/2026	50.35
2076	U.S. Cellular	0813661138	Street - Cell Phone Charges	06/06/2026	34.24
2076	U.S. Cellular	0813661138	MARS - Cell Phone Charges	06/06/2026	118.69
2076	U.S. Cellular	0813661138	MARS - Tablet Data Charges	06/06/2026	163.60
9920	WINDSTREAM	092151344-MAY26	Library Phone Service	05/26/2026	99.21
9920	WINDSTREAM	092226581-MAY26	Airport phone service	05/26/2026	86.29
9920	WINDSTREAM	092256506-JUN26	Utility Billing fax service	06/01/2026	70.54
9920	WINDSTREAM	092256507-JUN26	WPC phone service	06/01/2026	64.88
9920	WINDSTREAM	092256543-JUN26	4) lines	06/03/2026	304.72
Total INFO TECH SERVICES:					174,524.41
Total INFO TECH SERV FUND:					174,524.41

Vendor	Vendor Name	Invoice Number	Description	Invoice Date	Net Invoice Amount
<b>SANITATION FUND</b>					
840	BEATRICE AREA SOLID WASTE AGNC	480-MAY26	Tonnage Fees - May 2026	05/31/2026	75,196.90
980	BEATRICE IRON AND METAL CO	114397	solenoid f/hook truck	05/30/2026	14.43
980	BEATRICE IRON AND METAL CO	114397	cleaner	05/30/2026	18.20
1350	BOARD OF PUBLIC WORKS	86-11937	MARS postage - May26	05/29/2026	847.14
2010	CITY MOTOR SUPPLY	917623	oil filter, air filter	06/01/2026	46.72
2010	CITY MOTOR SUPPLY	917623	2) synthetic oil	06/01/2026	44.23
2060	CITY SELF INSURED HEALTH PLAN	JUNE 2026	Sanitation Health Insurance	06/01/2026	39,200.00
2080	CITY TREASURER	JUN26-IT SANITATION	IT Services	06/01/2026	2,071.00
2080	CITY TREASURER	SANITATION-JUN26	Accounting Services	06/01/2026	7,417.00
12693	Diversified Safety and Compliance LLC	26-061372	Clearinghouse - Full Query f/Weaver	06/05/2026	70.00
3210	FARMERS COOPERATIVE	2265-MAY26-MARS	20.795 gal Super E89 @ 4.06492	05/31/2026	84.53
3210	FARMERS COOPERATIVE	44577-MAY26	28.641 gal Super E89 @ 4.049	05/31/2026	115.97
3210	FARMERS COOPERATIVE	44577-MAY26	24.207 gal Super E89 @ 4.249	05/31/2026	102.86
3210	FARMERS COOPERATIVE	44577-MAY26	230.05 bulk DEF @ 2.34	05/31/2026	538.32
3210	FARMERS COOPERATIVE	44577-MAY26	13.92 gal E15 @ 3.999	05/31/2026	55.67
3210	FARMERS COOPERATIVE	44577-MAY26	7.9 lb Propane @ 3.00	05/31/2026	28.70
3210	FARMERS COOPERATIVE	44577-MAY26	19.746 gal Super E89 @ 4.229	05/31/2026	83.51
3210	FARMERS COOPERATIVE	44577-MAY26	Labor - 2) tire repair	05/31/2026	130.00
3210	FARMERS COOPERATIVE	44577-MAY26	Supplies - 8) tire	05/31/2026	4,216.00
12103	Firststar Fiber Inc	30817	January 2026 Recycling Tipping Fee	01/31/2026	3,742.49
12103	Firststar Fiber Inc	31046	February 2026 Recycling Tipping Fee	02/28/2026	4,973.61
12591	Interstate Power Systems, Inc	C023010190.01	Supplies - 1) brake shoe	06/08/2026	209.79
12591	Interstate Power Systems, Inc	R023067248.01	Labor - inspect brake components	06/05/2026	180.00
12591	Interstate Power Systems, Inc	R023067248.01	Misc Charges	06/05/2026	90.00
12591	Interstate Power Systems, Inc	R023067248.01	Labor - R&R pigtail	06/05/2026	360.00
12591	Interstate Power Systems, Inc	R023067248.01	Supplies - pigtail	06/05/2026	31.15
12591	Interstate Power Systems, Inc	R023067249.01	Labor - R&R hydraulic lines	06/04/2026	1,750.00
12591	Interstate Power Systems, Inc	R023067249.01	Supplies - hydraulic lines	06/04/2026	717.09
12591	Interstate Power Systems, Inc	R023067249.01	Misc Charges	06/04/2026	90.00
12591	Interstate Power Systems, Inc	R023067302.01	Labor - R&R wheel kit, brake drum, brake shoe	06/05/2026	1,540.80
12591	Interstate Power Systems, Inc	R023067302.01	Supplies - 4) wheel kit	06/05/2026	620.96
12591	Interstate Power Systems, Inc	R023067302.01	Supplies - 2) brake drum	06/05/2026	833.24
12591	Interstate Power Systems, Inc	R023067302.01	Supplies - 4) drum	06/05/2026	960.04
12591	Interstate Power Systems, Inc	R023067302.01	Supplies - 1) brake shoe	06/05/2026	209.79
12591	Interstate Power Systems, Inc	R023067302.01	Misc Charges	06/05/2026	90.00
12591	Interstate Power Systems, Inc	R023067302.01	Shop supplies	06/05/2026	206.93
12591	Interstate Power Systems, Inc	R023067344.01	Labor - ac not cooling - no problem found	06/09/2026	360.00
12591	Interstate Power Systems, Inc	R023067344.01	Misc Charges	06/09/2026	90.00
5110	LAMPTON WELDING SUPPLY Co., INC	0020378706	oxygen	06/02/2026	32.28
12084	One Source Parts, LLC	1058748	1) upper arm harness	06/01/2026	780.93
7060	O'REILLY AUTO PARTS	0749-156295	1-pk) shop towel	05/28/2026	18.99
7060	O'REILLY AUTO PARTS	0749-156295	12) brake cleaner	05/28/2026	41.88
7060	O'REILLY AUTO PARTS	0749-157471	1) air filter, 1) oil filter	06/02/2026	20.54
7060	O'REILLY AUTO PARTS	0749-157471	12) shop towel, 2) brake cleaner, 6) glass cleaner	06/02/2026	137.33
7060	O'REILLY AUTO PARTS	0749-157471	2) 1-qt oil, 1) 5-qt oil	06/02/2026	54.97
7060	O'REILLY AUTO PARTS	0749-157974	head gasket repair	06/04/2026	39.99
11311	Paymenttech	5707000-MAY26	Monthly CC Fees - Sanitation	05/31/2026	785.48
8260	SAPP BROTHERS	IN5038137	629.4 gal ULSD #2 Clear Summer Diesel @ 3.02798	06/01/2026	1,905.82
11678	Truck Center Companies	XA108221549.01	3) air panal ventilation	06/08/2026	40.05
11418	VISA	20081-MAY26-M	12) hi-vis t shirt	06/02/2026	96.84
11418	VISA	20081-MAY26-M	4-bx) dog bone	06/02/2026	35.92
11418	VISA	20081-MAY26-M	4-pk) shop towel	06/02/2026	73.25
11418	VISA	20081-MAY26-M	3) 12-pk pen	06/02/2026	43.50
11418	VISA	20081-MAY26-M	12) mini first aid kit	06/02/2026	119.88
11418	VISA	20081-MAY26-M	hook latch kit	06/02/2026	15.59

Vendor	Vendor Name	Invoice Number	Description	Invoice Date	Net Invoice Amount
11418	VISA	20081-MAY26-M	2) hitch replacement f/clevis hook trailer	06/02/2026	19.98
11312	Xpress Bill Pay	INV-XPR036118	Monthly CC Fees - Sanitation	05/31/2026	496.30
Total :					152,096.59
Total SANITATION FUND:					152,096.59
Grand Totals:					988,842.64

Dated: 6-15-26

Mayor: \_\_\_\_\_

City Council: \_\_\_\_\_

\_\_\_\_\_  
\_\_\_\_\_  
\_\_\_\_\_  
\_\_\_\_\_  
\_\_\_\_\_  
\_\_\_\_\_  
\_\_\_\_\_

Invoice Number	Invoice Date	Description	Segment Fund	Net Invoice Amount
<b>ELECTRIC FUND</b>				
27503	06/01/2026	Transfer Fee: Cotonwood Wind4 5/2026	ELECTRIC FUND	56.89
356733	06/04/2026	Legal Services-Power Plant thru 5/31/26	ELECTRIC FUND	1,290.00
222-MAY26	05/31/2026	#1097-3.0tX12.00	ELECTRIC FUND	36.00
222-MAY26	05/31/2026	#1267-2.0tX12.00	ELECTRIC FUND	24.00
222-MAY26	05/31/2026	#1431-5.46tX2.340	ELECTRIC FUND	12.78
222-MAY26	05/31/2026	#1514-4.0tX12.00	ELECTRIC FUND	48.00
114502	06/04/2026	1)Battery @171.70(cust#1072)	ELECTRIC FUND	171.70
114502	06/04/2026	Core	ELECTRIC FUND	20.00
114502	06/04/2026	Core exchange	ELECTRIC FUND	20.00-
114502	06/04/2026	Sales Tax	ELECTRIC FUND	12.88
932543400	06/01/2026	118)SERVENS 1 STR 2 SOL BUR - ES2R2W	ELECTRIC FUND	97.68
932543408	06/01/2026	30)CHN - C4060530 CLAMP PIN (2-3 WEEKS)	ELECTRIC FUND	419.89
932543416	06/01/2026	2)CLEVIS DEAD END SMALL CHN - 0337	ELECTRIC FUND	31.39
932582424	06/08/2026	58)CLEVIS DEAD END SMALL CHN - 0337	ELECTRIC FUND	910.32
932582424	06/08/2026	25)ARRESTOR LIGHTNING UG/OH 10 KV CHN-2137097324	ELECTRIC FUND	1,786.38
1131.01-JUN26	06/01/2026	Electric Building Repair Fund	ELECTRIC FUND	1,250.00
JUN2026-SERIES	06/01/2026	Electric Series 2025 Bonds	ELECTRIC FUND	16,476.00
12058900-MAY26	06/05/2026	Utilities/Electric/Sub 1	ELECTRIC FUND	238.81
21104500-MAY26	06/05/2026	Utilities/electric/Sub 3	ELECTRIC FUND	123.12
31004001-MAY26	06/05/2026	Utilities/electric/Sub 5	ELECTRIC FUND	208.90
31013810-MAY26	06/05/2026	Utilities/electric/Switch Station #1	ELECTRIC FUND	11.51
37039110-MAY26	06/05/2026	Utilities/electric/Sub 2	ELECTRIC FUND	29.87
40013500-MAY26	06/05/2026	Utilities/electric/Sub 6	ELECTRIC FUND	139.43
4002110-MAY26	06/05/2026	Utilities/Electric/1st & Ella Security Light	ELECTRIC FUND	11.51
40033500-MAY26	06/05/2026	Utilities/Electric/Sub 9	ELECTRIC FUND	165.18
40057700-MAY26	06/05/2026	Utilities/electric/500 N Commerce	ELECTRIC FUND	431.91
40086010-MAY26	06/05/2026	Utilities/Electric/Sub 7	ELECTRIC FUND	14.65
40116000-MAY26	06/05/2026	Utilities/Electric/Sub 4	ELECTRIC FUND	148.47
40137200-MAY26	06/05/2026	Utilities/electric/Sub 10	ELECTRIC FUND	145.13
40260500-MAY26	06/05/2026	Utilities/Water/South Reservoir	ELECTRIC FUND	3,819.14
5013000-MAY26	06/05/2026	Utilities/electric/400 Ella	ELECTRIC FUND	527.72
26060223191996	06/02/2026	After Hours Call Service Elec	ELECTRIC FUND	157.62
26060223191996	06/02/2026	After Hours Call Service St	ELECTRIC FUND	157.60
87714	06/04/2026	1cs)Towel Roll Kitcen 9x11@32.25	ELECTRIC FUND	32.25
87714	06/04/2026	Sales Tax	ELECTRIC FUND	2.42
ED-JUN26	06/01/2026	Economic Development Support-JUN26	ELECTRIC FUND	25,000.00
AMBULAR	06/08/2026	Ambul AR-Oxford House	ELECTRIC FUND	100.00
ATTY-JUN26	06/01/2026	Attorney Salary -Jun26	ELECTRIC FUND	4,257.00
CR-JUN26	06/01/2026	Community Relations Coord(50% of Amanda)-JUN26	ELECTRIC FUND	2,747.00
FINANCE-HR-JUN26	06/01/2026	Finance/HR Salary-JUN26	ELECTRIC FUND	8,424.00
GARBAGE-MAY26	06/08/2026	Garbage-MAY26	ELECTRIC FUND	127,994.94
GM-JUN26	06/01/2026	General Manager Salary -JUN26	ELECTRIC FUND	10,933.00
IT-JUN26	06/01/2026	IT Monthly Contribution -JUN26	ELECTRIC FUND	40,030.00
PLUS-MAY26	06/08/2026	Beatrice Plus-MAY26	ELECTRIC FUND	2,371.09
186-APR26	04/30/2026	Collections/April 2026	ELECTRIC FUND	265.19
186-MAY26	05/29/2026	Collections/May 2026	ELECTRIC FUND	725.60
S012008082.001	05/28/2026	1)Combination Pliers@30.39	ELECTRIC FUND	30.39
S012008082.001	05/28/2026	2)25/box 5 port Lever nut @@.95060	ELECTRIC FUND	47.53
S012008082.001	05/28/2026	1)50/box 3 port lever nut @.59500	ELECTRIC FUND	29.75
S012008082.001	05/28/2026	20)Pass CR20w dplx rcpt@4.39	ELECTRIC FUND	87.80
S012008082.001	05/28/2026	Sales Tax	ELECTRIC FUND	14.66
S012009360.001	05/28/2026	50)THHN 1/0 Stranded Black Wire @4.251	ELECTRIC FUND	212.55
S012009360.001	05/28/2026	Sales Tax	ELECTRIC FUND	15.94
HEALTH INS-JUN26	06/01/2026	Engineering Health Ins	ELECTRIC FUND	8,400.00
HEALTH INS-JUN26	06/01/2026	Electric Health Ins	ELECTRIC FUND	36,400.00
HEALTH INS-JUN26	06/01/2026	Billing & Service-elec	ELECTRIC FUND	5,600.00

Invoice Number	Invoice Date	Description	Segment Fund	Net Invoice Amount
HEALTH INS-JUN26	06/01/2026	Jean & Zab-elec	ELECTRIC FUND	2,800.00
2268-MAY26	05/31/2026	1)Filter -fuel (tanks)	ELECTRIC FUND	13.99
2268-MAY26	05/31/2026	Sales Tax	ELECTRIC FUND	.77
228335	05/31/2026	Fuel Site Modeul Monthly Service-MAY26	ELECTRIC FUND	86.00
228335	05/31/2026	State Sales/Use	ELECTRIC FUND	4.40-
228335	05/31/2026	City Sales/Use	ELECTRIC FUND	1.60-
27614	06/01/2026	10)LED 12" Insert,Green Ball.Clear@73.00	ELECTRIC FUND	730.00
27614	06/01/2026	Shipping	ELECTRIC FUND	25.00
9933486004	05/29/2026	2)Owl Decoy@53.69	ELECTRIC FUND	107.38
9933486004	05/29/2026	Sales Tax	ELECTRIC FUND	8.06
9934669632	06/01/2026	1)Portable Air Conditioner @315.74(sub7)	ELECTRIC FUND	315.74
9934669632	06/01/2026	Shipping	ELECTRIC FUND	30.00
9934669632	06/01/2026	Sales Tax	ELECTRIC FUND	25.93
84499	06/02/2026	50)IPEX EE2090 1" 90 DEG ELBOW	ELECTRIC FUND	92.99
84520	06/03/2026	1,000)WIRE COPPER 1/0 TBWP 19 STR, XLP/USE-2 600 VOLT	ELECTRIC FUND	5,014.88
84758	06/09/2026	2,000)WIRE COPPER #4 BARE SD SOLID (10 x 200 FT. REELS)	ELECTRIC FUND	2,190.85
1891	05/18/2026	Pest Control Service Center May/26	ELECTRIC FUND	80.63
90431334	06/02/2026	SaaS Monthly flat Fee/May26	ELECTRIC FUND	3,645.00
9313531049	06/05/2026	12)Aersl Opn&Sht Nut&Blt Loosnr & Rust@29.1133	ELECTRIC FUND	375.56
9313531049	06/05/2026	12)Ogle Glass Cleaner, Aerosol@17.3033	ELECTRIC FUND	223.21
9313531049	06/05/2026	24)Persist Grease 14.5oz Cartridge@23.8450	ELECTRIC FUND	615.20
9313531049	06/05/2026	6)Ready Orange Wipes @41.77	ELECTRIC FUND	269.42
9313531049	06/05/2026	State Sales/Use	ELECTRIC FUND	75.89-
9313531049	06/05/2026	City Sales/Use	ELECTRIC FUND	27.60-
13566049	06/04/2026	4)T25x2" Torx Power bit @5.27	ELECTRIC FUND	21.08
13566049	06/04/2026	1)Packout 10-bin small organizer @52.97	ELECTRIC FUND	52.97
13566049	06/04/2026	Sales Tax	ELECTRIC FUND	5.55
47729	06/03/2026	Power Bill/Transmission-May26	ELECTRIC FUND	22,166.19
9000063674	05/31/2026	2) MTR Translation & Rpt Mtr Srv--Comb Rpt	ELECTRIC FUND	192.00
6050131	05/31/2026	Elec-locate fees	ELECTRIC FUND	42.63
6050131	05/31/2026	Street-locate fees	ELECTRIC FUND	42.62
0749-159059	06/09/2026	1)BlueDEF 2.5@19.10	ELECTRIC FUND	19.10
0749-159059	06/09/2026	Sales Tax	ELECTRIC FUND	1.43
MAY26	06/01/2026	Internet Banking Fees MAY 2026	ELECTRIC FUND	41.00
125402	06/05/2026	20,000)Time Sheets/Split	ELECTRIC FUND	133.74
125402	06/05/2026	20,000)Time Sheets/Split	ELECTRIC FUND	133.73
125407	06/05/2026	The Beat Flyer/split cost	ELECTRIC FUND	678.70
125407	06/05/2026	USE TAX	ELECTRIC FUND	50.90
125407	06/05/2026	State Sales/Use Tax	ELECTRIC FUND	37.33-
125407	06/05/2026	City Sales/Use Tax	ELECTRIC FUND	13.57-
IN5038104	06/01/2026	591.60)DIESEL #2 DYED WITH ADDITIVE PACKAGE, CONTRACT FUEL	ELECTRIC FUND	1,602.05
IN5038757	06/02/2026	900)DIESEL #2 DYED WITH ADDITIVE PACKAGE, CONTRACT FUEL FO	ELECTRIC FUND	2,437.20
IN5038757	06/02/2026	1100)UNLEADED GASOLINE E-10 CONTRACT FUEL FOR 2026	ELECTRIC FUND	2,876.50
8070	05/21/2026	Pre emergent/Crabgrass Control/Fertilizer4 5/20/26	ELECTRIC FUND	80.00
8070	05/21/2026	Broadleaf Control 5/20/26	ELECTRIC FUND	80.00
485212	05/29/2026	2)Surface Mount 1 3/4x1 @5.24	ELECTRIC FUND	10.48
485212	05/29/2026	Sales Tax	ELECTRIC FUND	.78
485318	05/29/2026	1)Trv DEF 5gal @16.99	ELECTRIC FUND	16.99
485318	05/29/2026	Sales Tax	ELECTRIC FUND	1.27
060826	06/08/2026	cycle billing postage	ELECTRIC FUND	1,535.62
BOX279-JUN26	06/01/2026	PO Box 279 - Annual	ELECTRIC FUND	184.00
20081-MAY26	06/02/2026	Walmart-Training mtg	ELECTRIC FUND	43.93
20081-MAY26	06/02/2026	Subway-Training mtg	ELECTRIC FUND	141.43
20081-MAY26	06/02/2026	Valentino-board mtg	ELECTRIC FUND	75.80
20081-MAY26	06/02/2026	Valentino-board mtg	ELECTRIC FUND	73.58
20081-MAY26	06/02/2026	USPS-samples	ELECTRIC FUND	12.65
20081-MAY26	06/02/2026	Walmart-Fairbury Storm-Meals/cooler	ELECTRIC FUND	213.60

Invoice Number	Invoice Date	Description	Segment Fund	Net Invoice Amount
20081-MAY26	06/02/2026	Caseys's-Fairbury Storm-Meals	ELECTRIC FUND	19.75
20081-MAY26	06/02/2026	Maatsch's- Fairbury storm-Diesel	ELECTRIC FUND	52.52
20081-MAY26	06/02/2026	Maatsch's-Fairbury Storm-diesel	ELECTRIC FUND	75.00
20081-MAY26	06/02/2026	Maatsch's-Fairbury Storm-Diesel	ELECTRIC FUND	75.00
20081-MAY26	06/02/2026	Maatsch's-Fairbury Storm-Diesel	ELECTRIC FUND	75.00
20081-MAY26	06/02/2026	Maatsch's -Fairbury Storm-Diesel	ELECTRIC FUND	75.00
20081-MAY26	06/02/2026	Maatsch's -Fairbury Storm-Diesel	ELECTRIC FUND	75.00
20081-MAY26	06/02/2026	Maatsch's -Fairbury Storm-Diesel	ELECTRIC FUND	75.00
20081-MAY26	06/02/2026	Maatsch's -Fairbury Storm-Diesel	ELECTRIC FUND	75.00
20081-MAY26	06/02/2026	Maatsch's -Fairbury Storm-Diesel	ELECTRIC FUND	75.00
20081-MAY26	06/02/2026	Maatsch's -Fairbury Storm-Diesel	ELECTRIC FUND	75.00
20081-MAY26	06/02/2026	Maatsch's -Fairbury Storm-Diesel	ELECTRIC FUND	75.00
20081-MAY26	06/02/2026	Jalisco Mexican -Fairbury Storm-Meals	ELECTRIC FUND	78.15
20081-MAY26	06/02/2026	Casey's-Fairbury Storm-Meals	ELECTRIC FUND	22.82
068709	06/02/2026	100)SERVENS 1 STR 2 SOL BUR ES2R2W	ELECTRIC FUND	96.75
10360621	06/01/2026	1)Animal Repl@19.79	ELECTRIC FUND	19.79
10360621	06/01/2026	Sales Tax	ELECTRIC FUND	1.48
10360736	06/09/2026	1)Cooler 5 gallon @32.39	ELECTRIC FUND	32.39
10360736	06/09/2026	Sales Tax	ELECTRIC FUND	2.43
Total ELECTRIC FUND:				352,834.41
<b>WATER FUND</b>				
365-MAY26	05/31/2026	#1068-2.0tX12.00	WATER FUND	24.00
365-MAY26	05/31/2026	#1254-3.00tX12.00	WATER FUND	36.00
365-MAY26	05/31/2026	#1389-4.0tX12.00	WATER FUND	48.00
365-MAY26	05/31/2026	#1453-1.0tX12.00	WATER FUND	12.00
365-MAY26	05/31/2026	#1483-1.0tX12.00	WATER FUND	12.00
365-MAY26	05/31/2026	#1688-5.0tX12.00	WATER FUND	60.00
365-MAY26	05/31/2026	#1749-5tX12.00	WATER FUND	60.00
365-MAY26	05/31/2026	#1772-3.0tX12.00	WATER FUND	36.00
365-MAY26	05/31/2026	#1823-8.0tX12.00	WATER FUND	96.00
365-MAY26	05/31/2026	#1902-5.0T x 12.00	WATER FUND	60.00
365-MAY26	05/31/2026	#1962-5.Tx12.00	WATER FUND	60.00
365-MAY26	05/31/2026	#2088-8.0Tx12.00	WATER FUND	96.00
365-MAY26	05/31/2026	#2088-8.0Tx12.00	WATER FUND	96.00
B1 756756	05/28/2026	1cy)L10AE3500@193.50	WATER FUND	193.50
B1 756756	05/28/2026	Fuel Surcharge	WATER FUND	3.65
B1 756756	05/28/2026	Sales Tax	WATER FUND	14.78
B1 756757	05/28/2026	30cy)Sand Fill & Water @68.00	WATER FUND	2,040.00
B1 756757	05/28/2026	Fuel Surcharge	WATER FUND	109.50
B1 756757	05/28/2026	Sales Tax	WATER FUND	161.21
B1 756758	05/28/2026	10cy)Sand Fill & Water @68.00	WATER FUND	680.00
B1 756758	05/28/2026	Fuel Surcharge	WATER FUND	36.50
B1 756758	05/28/2026	Sales Tax	WATER FUND	53.74
B1 757118	06/02/2026	5.75)47B1S383500HW @197.50	WATER FUND	1,135.63
B1 757118	06/02/2026	Fuel Surcharge	WATER FUND	23.00
B1 757118	06/02/2026	Sales Tax	WATER FUND	86.90
B1 757119	06/02/2026	10.50)Sand Fill & water@68.00	WATER FUND	714.00
B1 757119	06/02/2026	Fuel Surcharge	WATER FUND	42.00
B1 757119	06/02/2026	Sales Tax	WATER FUND	56.70
B1 757139	06/03/2026	2.50CY)47B1S383500HW @197.50	WATER FUND	493.75
B1 757139	06/03/2026	Fuel Surcharge	WATER FUND	10.00
B1 757139	06/03/2026	Sales Tax	WATER FUND	37.78
B1 757160	06/04/2026	6.75cy)47B1S383500HW @197.50	WATER FUND	1,333.13
B1 757160	06/04/2026	6.75)NCA 10oz-1%@7.50	WATER FUND	50.63
B1 757160	06/04/2026	Fuel Surcharge	WATER FUND	27.00
B1 757160	06/04/2026	Sales Tax	WATER FUND	105.81
B1 757161	06/04/2026	9.0cy)Sand Fill & Water @68.00	WATER FUND	612.00
B1 757161	06/04/2026	Fuel Surcharge	WATER FUND	36.00
B1 757161	06/04/2026	Sales Tax	WATER FUND	48.60
B1 757392	06/08/2026	27cy)Sand Fill & Water@68.00	WATER FUND	1,836.00

Invoice Number	Invoice Date	Description	Segment Fund	Net Invoice Amount
B1 757392	06/08/2026	Fuel Surcharge	WATER FUND	108.00
B1 757392	06/08/2026	Sales Tax	WATER FUND	145.80
592852	05/29/2026	1)sawsall Blade@24.99	WATER FUND	24.99
592852	05/29/2026	1)Socket , Impact deep@12.79	WATER FUND	12.79
592852	05/29/2026	1)Vise Grips@17.99	WATER FUND	17.99
592852	05/29/2026	1)Hammer Cross @15.99	WATER FUND	15.99
592852	05/29/2026	Sales Tax	WATER FUND	5.38
595394	06/04/2026	1)Broom,Push @16.99	WATER FUND	16.99
595394	06/04/2026	Sales Tax	WATER FUND	1.27
932592863	06/09/2026	101)AMI PIT MOUNT MODULE HUTL-W2529-64170 SER5 W/2FT	WATER FUND	18,457.75
1131.01-JUN26	06/01/2026	Water Building Repair Fund	WATER FUND	850.00
JUN2026	06/01/2026	Water D311674 - SFR Land	WATER FUND	3,611.00
JUN2026	06/01/2026	Water D311685 - SRF Projects	WATER FUND	20,770.00
JUN2026-SERIES	06/01/2026	Water Series 2025 Bonds	WATER FUND	8,007.00
1456.00-JUN26	06/01/2026	Water Engineering Charges	WATER FUND	3,903.00
21104000-MAY26	06/05/2026	Utilities/Water/19th & Hoyt	WATER FUND	72.81
38146000-MAY26	06/05/2026	Utilities/Water/Mulberry & West	WATER FUND	110.26
40013000-MAY26	06/05/2026	Utilities/Water Reed & W Scott	WATER FUND	260.44
40031000-MAY26	06/05/2026	Utilities/Water/Hoyt Rd & Blueridge	WATER FUND	23.04
40057600-MAY26	06/05/2026	Utilities/Water/500 N Commerce	WATER FUND	1,075.18
40260000-MAY26	06/05/2026	Utilities/Water/North Reservoir	WATER FUND	3,473.71
40261000-MAY26	06/05/2026	Utilities/Water/Wells Hoag	WATER FUND	3,820.15
45016000-MAY26	06/05/2026	Utilities/Water RR3	WATER FUND	22.80
26060223191996	06/02/2026	After Hours Call Service Water	WATER FUND	157.62
ATTY-JUN26	06/01/2026	Attorney Salary -Jun26	WATER FUND	2,554.00
CR-JUN26	06/01/2026	Community Relations Coord(50% of Amanda)-JUN26	WATER FUND	1,648.20
FINANCE-HR-JUN26	06/01/2026	Finance/HR Salary-JUN26	WATER FUND	5,054.40
GM-JUN26	06/01/2026	General Manager Salary -JUN26	WATER FUND	6,559.80
IT-JUN26	06/01/2026	IT Monthly Contribution -JUN26	WATER FUND	13,614.00
7FF24556-0734	05/27/2026	Notice of Meeting 6/10/26	WATER FUND	13.02
124203	06/08/2026	Epp Condemnation Proceeding-File #1008040-0002(thru 5/31/26))	WATER FUND	105.00
HEALTH INS-JUN26	06/01/2026	Water Health Ins	WATER FUND	28,000.00
HEALTH INS-JUN26	06/01/2026	Billing & Service-wtr	WATER FUND	3,360.00
HEALTH INS-JUN26	06/01/2026	Jean & Zab-wtr	WATER FUND	1,680.00
2266-MAY26	05/31/2026	Tire Repair	WATER FUND	25.00
2266-MAY26	05/31/2026	1)245/75R17/E Kook@240.00	WATER FUND	240.00
2266-MAY26	05/31/2026	Tire disposal	WATER FUND	6.50
2266-MAY26	05/31/2026	Tire Tax	WATER FUND	1.00
2266-MAY26	05/31/2026	sales Tax	WATER FUND	18.49
13580	06/01/2026	3)Service Remotely@350.00 (S resv)	WATER FUND	1,050.00
13580	06/01/2026	.75)Field Labor @350.00	WATER FUND	262.50
13580	06/01/2026	1.5)Field Labor @195.00	WATER FUND	292.50
13580	06/01/2026	82)Milleage	WATER FUND	82.00
13580	06/01/2026	1)Altech Power Supply@587.30	WATER FUND	587.30
13580	06/01/2026	4)Zeus 12Volt AH Battery@37.54	WATER FUND	150.16
13580	06/01/2026	2.5)Field Labor @175.00	WATER FUND	437.50
13580	06/01/2026	1.5)Travel labor @130.00	WATER FUND	195.00
13580	06/01/2026	82)Milleage	WATER FUND	82.00
13580	06/01/2026	2)9SX1500 UPS@1649.00	WATER FUND	3,298.00
13580	06/01/2026	City Use Tax	WATER FUND	101.71
13580	06/01/2026	City Sales/Use	WATER FUND	101.71-
13580	06/01/2026	Sales Tax	WATER FUND	279.70
R023067268 01	06/03/2026	Labor-Starter	WATER FUND	900.00
R023067268 01	06/03/2026	1)Starter-12V@659.40	WATER FUND	659.40
R023067268 01	06/03/2026	1)Copper Lugs @14.15	WATER FUND	14.15
R023067268 01	06/03/2026	12)Cable 2 gauge @10.10	WATER FUND	121.20
R023067268 01	06/03/2026	2)Battery@128.39	WATER FUND	256.78

Invoice Number	Invoice Date	Description	Segment Fund	Net Invoice Amount
R023067268 01	06/03/2026	Battery Core	WATER FUND	65.34
R023067268 01	06/03/2026	Battery Core Exchange	WATER FUND	65.34-
R023067268 01	06/03/2026	Fuel Surcharge	WATER FUND	20.00
R023067268 01	06/03/2026	Diagnotice/Tech Services	WATER FUND	63.00
R023067268 01	06/03/2026	Shop Supplies	WATER FUND	129.33
R023067268 01	06/03/2026	Use Tax	WATER FUND	90.06
R023067268 01	06/03/2026	State Sales/Use	WATER FUND	66.05-
R023067268 01	06/03/2026	City Sales/Use	WATER FUND	24.01-
119411 03	05/28/2026	4)Hydrant 6" Pumper 5.5' Bury K81 HYD 5-1/4 5-0 OL 3W FOREST GREE	WATER FUND	13,332.00
119657 03	05/28/2026	3)Hydrant 6" Pumper 5.5' Bury 5-1/4" BURY OL 3WAY	WATER FUND	10,050.00
120193 01	06/04/2026	1)8" x 8" Tee Cast Iron DI MJ	WATER FUND	344.00
120193 01	06/04/2026	1)708YS22 1X3/4 Y-BRANCH CTS X C 5140-121	WATER FUND	70.18
120193 01	06/04/2026	1)1650600 6 506SS CHECK VALVE	WATER FUND	1,063.18
120193 01	06/04/2026	2)6" & 8" FLANGE STAINLESS BOLT PACK	WATER FUND	71.46
120193 01	06/04/2026	2)6" FLG RED RUBBER GASKET	WATER FUND	14.90
120193 02	06/08/2026	15)72" RHINO 3-RAIL MARKING POST	WATER FUND	796.41
120939 01	06/10/2026	1)6" 826 FLG LW CHECK VALVE 14-204-0600	WATER FUND	2,148.93
13547383	06/01/2026	1)2x10-12 select struct #1@20.84	WATER FUND	20.84
13547383	06/01/2026	Sales Tax	WATER FUND	1.57
311885100-MAY26	06/05/2026	Power Bill/City Wells/May2026	WATER FUND	5,886.69
6050131	05/31/2026	Water-locate fees	WATER FUND	42.63
0749-153938	05/18/2026	2)Battery@150.81	WATER FUND	301.62
0749-153938	05/18/2026	Sales Tax	WATER FUND	22.62
0749-156197	05/28/2026	1)Battery@100.27	WATER FUND	100.27
0749-156197	05/28/2026	Core Charge	WATER FUND	22.00
0749-156197	05/28/2026	Core Exchange	WATER FUND	22.00-
0749-156197	05/28/2026	Sales Tax	WATER FUND	7.52
94799476	06/01/2026	Billing for Generator Service Agreement (Wells/Resv)	WATER FUND	7,022.29
125402	06/05/2026	20,000)Time Sheets/Split	WATER FUND	133.74
RO51826	05/01/2026	Labor-AC	WATER FUND	980.00
RO51826	05/01/2026	Compressor, filters, belts, o'rings	WATER FUND	1,083.57
RO51826	05/01/2026	Freight	WATER FUND	238.93
RO51826	05/01/2026	Labor -Water pump leaking	WATER FUND	490.00
RO51826	05/01/2026	Water Pump, Gaskets, Counter, Sealing	WATER FUND	225.70
RO51826	05/01/2026	Sales tax	WATER FUND	116.12
RO51826	05/01/2026	Sales tax	WATER FUND	110.25
2606-176041	06/01/2026	2)2x4-8 Treated Lumber(well7)	WATER FUND	11.98
2606-176041	06/01/2026	1)Brown 12 Turbine vent/base @98.69	WATER FUND	98.69
2606-176041	06/01/2026	Sales Tax	WATER FUND	8.30
2606-176533	06/02/2026	1)7" Magnum rafter sq@13.99	WATER FUND	15.04
2606-176533	06/02/2026	1)Bolts, Nuts, Washers, Screws, Fasteners	WATER FUND	13.96
2606-176805	06/03/2026	3) Bristle brush, 3) Poly Brush, roof cement	WATER FUND	44.42
64498	06/09/2026	1900)Bore 8" Certalok @29.69	WATER FUND	56,411.00
64498	06/09/2026	242)1" Bore@15.00	WATER FUND	3,630.00
64498	06/09/2026	40)2" Bore @15.00	WATER FUND	600.00
060826	06/08/2026	cycle billing postage	WATER FUND	921.37
BOX279-JUN26	06/01/2026	PO Box 279 - Annual	WATER FUND	110.40
20081-MAY26	06/02/2026	Zoro-Steel Probe	WATER FUND	59.97
20081-MAY26	06/02/2026	Zoro-Pressure Gauge	WATER FUND	53.20
20081-MAY26	06/02/2026	Menards-Sump Pump	WATER FUND	139.41
20081-MAY26	06/02/2026	NTA-CDL Training -Hudson	WATER FUND	299.00
20081-MAY26	06/02/2026	Amazon-Beverage Cooler	WATER FUND	52.07
20081-MAY26	06/02/2026	Amazon-T-Shirts	WATER FUND	88.65
20081-MAY26	06/02/2026	USPS-samples	WATER FUND	18.40
20081-MAY26	06/02/2026	Amazon-stencils	WATER FUND	13.94
20081-MAY26	06/02/2026	Amazon-Cooling Fan	WATER FUND	52.62
20081-MAY26	06/02/2026	Harbor Freight-Tool	WATER FUND	154.76

Invoice Number	Invoice Date	Description	Segment Fund	Net Invoice Amount
10360637	06/02/2026	4)Tube Strap @.89	WATER FUND	3.56
10360637	06/02/2026	5)Tube Strap @.71	WATER FUND	3.55
10360637	06/02/2026	1)Strap hangr@4.49	WATER FUND	4.49
10360637	06/02/2026	Sales Tax	WATER FUND	.87
10360701	06/05/2026	1)Trmmr Ln@21.59	WATER FUND	21.59
10360701	06/05/2026	Sales Tax	WATER FUND	1.62
108845	06/08/2026	2)Dryer Hose Clamps @3.24(well f5)	WATER FUND	6.48
108845	06/08/2026	1)3/4" Thread Ball Valve @30.00	WATER FUND	30.00
108845	06/08/2026	Sales Tax	WATER FUND	2.74
Total WATER FUND:				254,909.20
<b>WPC</b>				
226-MAY26	05/31/2026	#928-2.64tX2.340	WPC	6.18
226-MAY26	05/31/2026	#1540-2.0tX12.0	WPC	24.00
226-MAY26	05/31/2026	#1718-3.80tX2.340	WPC	8.89
SLUDGE-MAY26	06/01/2026	SLUDGE MAY 2026	WPC	15,758.24
218898	05/27/2026	Labor-Diagnostic (admin bld not cooling)	WPC	115.00
218898	05/27/2026	Labor-Replace condenser fan motor	WPC	448.00
218898	05/27/2026	Condenser motor	WPC	190.63
218898	05/27/2026	24" fan blade	WPC	143.00
218898	05/27/2026	Capacitor	WPC	19.01
218898	05/27/2026	Refrigerant 410A	WPC	219.57
IN0033020	05/21/2026	6,000)Printed 4x5 Vinyl Flags 18"-Green@.0927	WPC	556.20
IN0033020	05/21/2026	FREIGHT	WPC	81.48
594444	06/02/2026	1)L&G Battery@44.99	WPC	44.99
594444	06/02/2026	Core fee	WPC	12.00
594487	06/02/2026	Core fee credit	WPC	12.00-
595780	06/05/2026	1)Air Conditioner@399.99(Headworks buld)	WPC	399.99
595780	06/05/2026	1)Foam Sealant@10.99	WPC	10.99
597058	06/08/2026	3)Disposable Gloves @14.99	WPC	44.97
597058	06/08/2026	1)Bit Tip @2.99	WPC	2.99
597058	06/08/2026	1)Bit Extension @6.99	WPC	6.99
597329	06/09/2026	2)Fuel ,50:1@16.99	WPC	33.98
597329	06/09/2026	1)Trimmer Line@13.49	WPC	13.49
597789	06/10/2026	2)Painters Wiping Rag @4.99	WPC	9.98
597789	06/10/2026	1)Paint Pail@10.99	WPC	10.99
597789	06/10/2026	2)Roller Cover @4.59	WPC	9.18
597789	06/10/2026	3)Brush,Paint@3.79	WPC	11.37
597789	06/10/2026	1)Alex Plus Caulk@3.99	WPC	3.99
597789	06/10/2026	1)Grease Gun@259.99	WPC	259.99
JUN2026-SERIES	06/01/2026	WPC Series 2025 Bonds	WPC	1,000.00
1456.00-JUN26	06/01/2026	WPC Engineering Charges	WPC	3,903.00
15051800-MAY26	06/05/2026	Utilities/WPC/Lift Station 424 irving	WPC	334.00
21176000-MAY26	06/05/2026	Utilities/WPC/Lift Station 1831 1/2 carlye	WPC	52.66
23001000-MAY26	06/05/2026	Utilities/WPC/Lift Station 204 s 1st	WPC	479.54
24107600-MAY26	06/05/2026	Utilities/WPC/Lift Station 2118 Market	WPC	32.77
32011800-MAY26	06/05/2026	Utilities/WPC/Lift Station 910 w Court	WPC	36.91
3504100-MAY26	06/05/2026	Utilities/WPC/Lift Station 624 Pleasant	WPC	41.39
37009500-MAY26	06/05/2026	Utilities/WPC/Lift Station 800 Herbert	WPC	369.23
39079000-MAY26	06/05/2026	Utilities/WPC/Disposal Plant	WPC	10,432.18
39079100-MAY26	06/05/2026	Utilities/WPC/Disposal Plant	WPC	117.74
39093000-MAY26	06/05/2026	Utilities/WPC/Lift Station 1618 country club In	WPC	79.11
021-01277-PMT10	06/09/2026	WPC Grit Improvements Project No. 021-01277	WPC	38,989.16
26060223191996	06/02/2026	After Hours Call Service Sewer	WPC	157.62
4268968288	05/12/2026	Uniform Cleaning/Rental WPC	WPC	35.00
4271256783	06/02/2026	Uniform Cleaning/Rental WPC	WPC	35.00

Invoice Number	Invoice Date	Description	Segment Fund	Net Invoice Amount
4271937798	06/09/2026	Uniform Cleaning/Rental WPC	WPC	35.00
917818	06/09/2026	1)Tlax z400 Shop 55ct @16.29	WPC	16.29
ATTY-JUN26	06/01/2026	Attorney Salary -Jun26	WPC	1,703.00
CR-JUN26	06/01/2026	Community Relations Coord(50% of Amanda)-JUN26	WPC	1,098.80
FINANCE-HR-JUN26	06/01/2026	Finance/HR Salary-JUN26	WPC	3,369.60
GM-JUN26	06/01/2026	General Manager Salary -JUN26	WPC	4,373.20
IT-JUN26	06/01/2026	IT Monthly Contribution -JUN26	WPC	9,432.00
7FF24556-0717	04/24/2026	Notice of Meeting 5/27/26	WPC	13.02
HEALTH INS-JUN26	06/01/2026	WPC Health Ins	WPC	16,800.00
HEALTH INS-JUN26	06/01/2026	Billing & Service-wpc	WPC	2,240.00
HEALTH INS-JUN26	06/01/2026	Jean & Zab - wpc	WPC	1,120.00
2267-MAY26	05/31/2026	24.6780 E15	WPC	93.75
2267-MAY26	05/31/2026	26.3660 E15-gas cans	WPC	98.85
2267-MAY26	05/31/2026	1)Summit Syngear	WPC	366.12
2267-MAY26	05/31/2026	15.7530 E15	WPC	63.00
2267-MAY26	05/31/2026	13.190 E15	WPC	52.75
2267-MAY26	05/31/2026	21.6150 E15-gas cans	WPC	86.01
2267-MAY26	05/31/2026	18.3350 E15	WPC	80.66
2267-MAY26	05/31/2026	3.1830 E15	WPC	14.00
2267-MAY26	05/31/2026	9.5470 E15	WPC	42.00
2267-MAY26	05/31/2026	21.5680 E15	WPC	90.56
13590	06/02/2026	1)Transmitters SITRANS LH100@1633.84 (LS #4)	WPC	1,633.84
13590	06/02/2026	Freight	WPC	20.83
13579636	06/08/2026	1)5lb PP Screw10x5@48.95	WPC	48.95
13579636	06/08/2026	1)Shockwave Impact powr bit@4.29	WPC	4.29
13579636	06/08/2026	1)T20 Torx Power bit @3.33	WPC	3.33
13579636	06/08/2026	1)8x1 3/4 Ton#1@13.43	WPC	13.43
13579636	06/08/2026	2)Asst/Screw/Bolt /Fastener @.69	WPC	1.38
13579636	06/08/2026	2)Asst/Screw/Bolt/Fastener@.25	WPC	.50
13579636	06/08/2026	4)Asst/Screw/Bolt/Fastener@.23	WPC	.92
13579636	06/08/2026	1)2x4-10 SYP Treated #1@7.34	WPC	7.34
1289396	06/02/2026	Weekly Wastewater Samples/May26	WPC	1,074.98
NE0022271	06/04/2026	1)Gauge 0-100 PSI @6.64	WPC	6.64
579906	05/26/2026	WPC Grit Improvement Project	WPC	20,683.00
6050131	05/31/2026	WPC-locate fees	WPC	42.63
227361	06/09/2026	1)PT-MIC-WP Micro Quantitative @159.00	WPC	159.00
227361	06/09/2026	1)QC-MIC-WP Micro Quantitative @147.00	WPC	147.00
227361	06/09/2026	Freight	WPC	86.64
227361	06/09/2026	Handling	WPC	12.00
125402	06/05/2026	20,000)Time Sheets/Split	WPC	133.74
32704	05/14/2026	8)Nut-Lug @1.19	WPC	9.52
32704	05/14/2026	3)Spk,Blade Notched @39.94	WPC	119.82
32822	06/08/2026	3)Spk,Blade Notched @39.94	WPC	119.82
768650	05/28/2026	1)Farmworks in/out insect @59.99	WPC	59.99
768650	05/28/2026	1)Blue Spray indicator @29.99	WPC	29.99
768650	05/28/2026	1)Corona Comfortgel bypass lopper @39.99	WPC	39.99
XA108214231.02	04/02/2026	1)Element-Air Filter Primary @117.50	WPC	117.50
XA108214231.02	04/02/2026	2)Lube Filter @99.95	WPC	199.90
060826	06/08/2026	cycle billing postage	WPC	614.25
BOX279-JUN26	06/01/2026	PO Box 279 - Annual	WPC	73.60
20081-MAY26	06/02/2026	Walmart-Plant Supplies	WPC	73.14
20081-MAY26	06/02/2026	Harbor Freight-Tool	WPC	34.99
20081-MAY26	06/02/2026	Zoro-Grease Zerk	WPC	48.87
20081-MAY26	06/02/2026	Walmart-Battery	WPC	149.84
20081-MAY26	06/02/2026	Zoro-Locating Pain	WPC	154.44
20081-MAY26	06/02/2026	Zoro-Plant Supplies	WPC	109.62
20081-MAY26	06/02/2026	Pomps Tire-Tires	WPC	924.05

Invoice Number	Invoice Date	Description	Segment Fund	Net Invoice Amount
20081-MAY26	06/02/2026	USA BlueBook-Lab Supplies	WPC	335.52
20081-MAY26	06/02/2026	Walmart-plant supplies	WPC	115.56
20081-MAY26	06/02/2026	NTA-CDL Training-Pyle	WPC	299.00
Total WPC:				143,427.86
Grand Totals:				751,171.47

Dated: \_\_\_\_\_

Mayor: \_\_\_\_\_

City Council: \_\_\_\_\_

\_\_\_\_\_  
\_\_\_\_\_  
\_\_\_\_\_  
\_\_\_\_\_  
\_\_\_\_\_  
\_\_\_\_\_  
\_\_\_\_\_

CERTIFICATE OF PAYMENT NO. 10



Date of Issuance: June 9, 2026

Project: WPC Grit Improvements, Beatrice, Nebraska

Project No. 021-01277

Contractor: Building Crafts, Inc PO Box 96 Red Oak, IA 51566

DETAILED ESTIMATE

Description	Unit Prices	Extension
See Attached.		

PLEASE REMIT PAYMENT TO: Building Crafts, Inc.

Value of Work Completed: \$1,957,364.29

Original Contract Cost: \$4,559,000.00  
 Approved Change Orders:  
 No. 1 \$(145,000.00)  
 Total Contract Cost: \$4,414,000.00

Value of completed work and materials stored..... \$1,957,364.29  
 Less retained percentage (10%) ..... \$ 195,736.43  
 Net amount due including this estimate..... \$1,761,627.86  
 Less: Estimates previously approved:

No. 1 \$ 279,946.65      No. 9 \$ 67,093.37  
 No. 2 \$ 202,228.08  
 No. 3 \$ 170,056.20  
 No. 4 \$ 147,785.83  
 No. 5 \$ 147,729.60  
 No. 6 \$ 105,423.65  
 No. 7 \$ 398,693.11  
 No. 8 \$ 203,682.21

Total Previous Estimates \$ 1,722,638.70

**NET AMOUNT DUE THIS ESTIMATE \$ 38,989.16**

The undersigned hereby certifies, based upon periodic observations as set forth in scope of work and the data included in all applicable payment applications that, to the best of its knowledge, information and belief: (1) the work has progressed as indicated in the applicable payment applications; (2) the work performed and materials delivered by Contractor are in conformance with the plans and specifications; and (3) the Contractor, in accordance with the contract, is entitled to payment as indicated above.

This certification does not constitute a warranty or guarantee of any type. Client shall hold its Contractor solely responsible for the quality and completion of the Project, including construction in accordance with the construction documents. Any duty or obligation of Olsson hereunder is for the sole benefit of the Client and not for any third party, including the Contractor or any Subcontractor.

cc: City of Beatrice, Owner  
Building Crafts, Inc, Contractor  
Project File

OLSSON

By: Martin J. Rink

**APPLICATION AND CERTIFICATION FOR PAYMENT**

TO OWNER: CITY OF BEATRICE	PROJECT: WPC GRIT IMPROVEMENTS	APPLICATION NO: 10
		PERIOD TO: May 31, 2026
FROM CONTRACTOR: BUILDING CRAFTS INC.	OWNER PROJECT OLSSON PROJECT #021-0127	ENGINEER: OLSSON
	BCI PROJECT # 2150	CONTRACT DATE: May 19, 2025

**CONTRACTOR'S APPLICATION FOR PAYMENT**

Application is made for payment, as shown below, in connection with the Contract.

1. ORIGINAL CONTRACT SUM .....	\$	4,559,000.00
2. NET CHANGE BY CHANGE ORDERS .....	\$	(145,000.00)
3. CONTRACT SUM TO DATE ( Line 1+/- 2 ) .....	\$	4,414,000.00
4. TOTAL COMPLETED & STORED TO DATE .....	\$	1,957,364.29
5. RETAINAGE: 10% .....	\$	195,736.43
6. TOTAL EARNED LESS RETAINAGE .....	\$	1,761,627.86
7. LESS PREVIOUS CERTIFICATES FOR PAYMENT .....	\$	1,722,638.70
8. CURRENT PAYMENT DUE .....	\$	38,989.16
9. BALANCE TO FINISH, INCLUDING RETAINAGE .....	\$	2,652,372.14

The undersigned Contractor certifies that to the best of the Contractor's knowledge, information, and belief the work covered by this Application for Payment has been completed in accordance with the Contract Documents, that all amounts have been paid by the Contractor in accordance with the terms and conditions of purchase orders and subcontract agreements for work for which previous Certificates for Payment were issued and payments received from the Owner and title to all materials and equipment incorporated in said work or otherwise listed in or covered by this application for progress payment will pass to the Owner at the time of payment free and clear of all liens, claims, security interests and encumbrances except such as covered by a bond acceptable to the Owner, and that current payment shown herein is now due.

Building Crafts, Inc.  
By: *Tony Lager* Date: 6/3/26  
Tony Lager, Project Manager

**ENGINEER'S APPROVAL FOR PAYMENT**

In accordance with the Contract Documents, based on on-site observations and the data comprising this application, the Engineer recommends to the owner that to the best of the Engineer's knowledge, information, and belief the work has progressed as indicated, the quality of the Work is in accordance with the Contract Documents, and the Contractor is entitled to the payment of the AMOUNT APPROVED.

OLSSON  
By: *Martin J Rink* Date: 6/9/26

This certificate is not negotiable. The AMOUNT CERTIFIED is payable only to the Contractor named herein. Issuance, payment and acceptance of payment are without prejudice to any rights of the Owner or Contractor under this contract.

Approved By: \_\_\_\_\_

CHANGE ORDER SUMMARY	Additions	Deductions
Total changes approved in previous months by Owner	\$0.00	(\$145,000.00)
Total approved this Month-	\$0.00	\$0.00
<b>TOTALS</b>	<b>\$0.00</b>	<b>(\$145,000.00)</b>
NET CHANGES by Change Order		(\$145,000.00)

		PROJECT: WPC GRIT IMPROVEMENTS, BEATRICE, NE	OWNER: CITY OF BEATRICE		APPLICATION NUMBER:		10			
		CONTRACTOR: BUILDING CRAFTS, INC.	OLSSON PROJECT: #021-01277		APPLICATION DATE:		6/3/2026			
Package Item	Item #	Item Description	Scheduled Value	Total Stored Matreial	Work Completed Previously	Work Completed This Period	Work Completed To Date	Total Combined	Percenty Stored & Complete	Balance to Finish
<b>WPC GRIT IMPROVEMENTS</b>										
<b>1</b>		<b>DIVISION 1 - General Conditions</b>								
	1.a	Mobilization	\$ 50,000.00	\$ -	\$ 50,000.00	\$ -	\$ 50,000.00	\$ 50,000.00	100%	\$ -
	1.b	Demobilization	\$ 50,000.00	\$ -	\$ -	\$ -	\$ -	\$ -	0%	\$ 50,000.00
	1.c	Management, Permits, and Utilities	\$ 279,600.00	\$ -	\$ 154,400.00	\$ -	\$ 154,400.00	\$ 154,400.00	55%	\$ 125,200.00
	1.d	Submittals	\$ 50,000.00	\$ -	\$ 44,000.00	\$ -	\$ 44,000.00	\$ 44,000.00	88%	\$ 6,000.00
	1.e	Allowance 1	\$ 24,067.00	\$ -	\$ -	\$ -	\$ -	\$ -	0%	\$ 24,067.00
	1.f	Allowance 2	\$ 248,800.00	\$ -	\$ -	\$ -	\$ -	\$ -	0%	\$ 248,800.00
	1.g	Bond, Insurance, & Misc	\$ 83,973.64	\$ -	\$ 55,234.00	\$ -	\$ 55,234.00	\$ 55,234.00	66%	\$ 28,739.64
	1.h	Equipment Rental, Clean up, and Project Safety	\$ 150,000.00	\$ -	\$ 98,550.00	\$ -	\$ 98,550.00	\$ 98,550.00	66%	\$ 51,450.00
<b>2</b>		<b>DIVISION 2 - Demolition</b>								
	2.a	Misc. Demolition	\$ 167,000.00	\$ -	\$ 2,500.00	\$ -	\$ 2,500.00	\$ 2,500.00	1%	\$ 164,500.00
<b>3</b>		<b>DIVISION 3 - Concrete</b>								
	3.a	Reinforcement Bar	\$ 141,400.00	\$ -	\$ 123,308.44	\$ 11,000.00	\$ 134,308.44	\$ 134,308.44	95%	\$ 7,091.56
	3.b	Concrete Curing	\$ 8,396.55	\$ -	\$ 2,500.00	\$ -	\$ 2,500.00	\$ 2,500.00	30%	\$ 5,896.55
	3.c	Bottom Slab Footings	\$ 23,000.00	\$ -	\$ 20,790.00	\$ 2,210.00	\$ 23,000.00	\$ 23,000.00	100%	\$ -
	3.d	Strip Footings	\$ 26,941.36	\$ -	\$ 24,932.75	\$ 2,008.61	\$ 26,941.36	\$ 26,941.36	100%	\$ -
	3.e	Tall Walls First Lift	\$ 185,639.44	\$ -	\$ 185,639.44	\$ -	\$ 185,639.44	\$ 185,639.44	100%	\$ -
	3.f	Short Walls & Trough	\$ 13,748.19	\$ -	\$ 13,748.19	\$ -	\$ 13,748.19	\$ 13,748.19	100%	\$ -
	3.g	Slab on Grade	\$ 14,403.05	\$ -	\$ 3,000.00	\$ 10,403.05	\$ 13,403.05	\$ 13,403.05	93%	\$ 1,000.00
	3.h	Columns	\$ 3,548.63	\$ -	\$ -	\$ 3,548.63	\$ 3,548.63	\$ 3,548.63	100%	\$ -
	3.i	Large & Small Structural Slab on Trough	\$ 8,900.00	\$ -	\$ 8,900.00	\$ -	\$ 8,900.00	\$ 8,900.00	100%	\$ -
	3.j	Grout Small and Large areas	\$ 60,616.64	\$ -	\$ 30,300.00	\$ -	\$ 30,300.00	\$ 30,300.00	50%	\$ 30,316.64
	3.k	Equipment Pads, Pipe Supports, and Misc Concrete	\$ 13,800.00	\$ -	\$ -	\$ -	\$ -	\$ -	0%	\$ 13,800.00
	3.l	Precast Embeds	\$ 8,744.00	\$ -	\$ 8,744.00	\$ -	\$ 8,744.00	\$ 8,744.00	100%	\$ -
<b>25</b>	3.m	Precast Structural Concrete and Grouting	\$ 281,540.00	\$ -	\$ 274,500.00	\$ -	\$ 274,500.00	\$ 274,500.00	97%	\$ 7,040.00
	3.n									
<b>4</b>		<b>DIVISION 5 - Metals</b>								
	4.a	Misc Metals - Materials	\$ 163,080.00	\$ 91,349.00	\$ -	\$ -	\$ -	\$ 91,349.00	56%	\$ 71,731.00
	4.b	Misc Metals - Labor	\$ 40,600.00	\$ -	\$ 5,800.00	\$ -	\$ 5,800.00	\$ 5,800.00	14%	\$ 34,800.00
<b>5</b>		<b>DIVISION 7 - Waterproofing, Roofing, and Insulation</b>								
	5.a	Waterproofing & Misc	\$ 14,856.00	\$ -	\$ 10,000.00	\$ 2,856.00	\$ 12,856.00	\$ 12,856.00	87%	\$ 2,000.00
	5.b	EPDM Roofing and Thermal Insulation	\$ 58,308.50	\$ -	\$ 45,000.00	\$ -	\$ 45,000.00	\$ 45,000.00	77%	\$ 13,308.50
	5.c	Joint Sealants	\$ 7,526.00	\$ -	\$ 1,500.00	\$ 2,000.00	\$ 3,500.00	\$ 3,500.00	47%	\$ 4,026.00
			\$ -	\$ -	\$ -	\$ -	\$ -	\$ -	#DIV/0!	\$ -
<b>6</b>		<b>DIVISION 8 - Openings</b>								
	6.a	Overhead Door	\$ 37,800.00	\$ -	\$ -	\$ -	\$ -	\$ -	0%	\$ 37,800.00
	6.b	Aluminum Doors and Windows	\$ 32,700.00	\$ 7,706.00	\$ -	\$ -	\$ -	\$ 7,706.00	24%	\$ 24,994.00
<b>7</b>		<b>DIVISION 9 - Painting and Coatings</b>								
	1.7a	Paintings	\$ 58,250.00	\$ -	\$ -	\$ -	\$ -	\$ -	0%	\$ 58,250.00
<b>8</b>		<b>DIVISION 10 - Specialities</b>								
	8.a	Signage and Fire Extinguishers	\$ 9,200.00	\$ -	\$ -	\$ -	\$ -	\$ -	0%	\$ 9,200.00



Package Item	Item #	Item Description	Scheduled Value	Total Stored Matreial	Work Completed Previously	Work Completed This Period	Work Completed To Date	Total Combined	Percenty Stored & Complete	Balance to Finish
TOTALS			\$ 4,559,000.00	\$ 331,430.19	\$ 1,701,707.81	\$ 69,226.29	\$ 1,770,934.10	\$ 2,102,364.29	46%	\$ 2,456,635.71
<b>Additional Work</b>										
1		Change Order 1	\$ (145,000.00)	\$ -	\$ (145,000.00)	\$ -	\$ (145,000.00)	\$ (145,000.00)	100%	\$ -
Total Sum to Date			\$ 4,414,000.00	\$ 331,430.19	\$ 1,556,707.81	\$ 69,226.29	\$ 1,625,934.10	\$ 1,957,364.29	44%	\$ 2,311,635.71

# Stored Material Summary

# Contractor's Application

For (contract): WPC GRIT IMPROVEMENTS			Owner's Proj. No.:				Application Number: <b>10</b>			
Contractor: Building Crafts Inc			Engineer's Proj. No.: #021-01277				Application Date: <b>5/29/2026</b>			
A	B	C	D	E		F		G		H
Invoice No.	Shop Drawing Transmittal No.	Line Item	Materials Description	Stored Previously		Stored this Month		Incorporated in Work		Materials Remaining in Storage (\$) (E - F)
				Date (Mo./Year)	Amount (\$)	Amount (\$)	Subtotal, \$ (D+E)	Date (Mo./Year)	Amount (\$)	
6807-05	03 20 00	3a	Reinforcement Bar	1/29/2026	\$ 5,705.00	\$ -	\$ 5,705.00	5/1/2026	\$ 5,705.00	\$ -
6807-04	03 20 00	3a	Reinforcement Bar	12/26/2025	\$ 2,300.00	\$ -	\$ 2,300.00	1/27/2026	\$ 2,300.00	\$ -
6807.2	03 20 00	3a	Reinforcement Bar	10/30/2025	\$ 18,315.00	\$ -	\$ 18,315.00	1/27/2026	\$ 18,315.00	\$ -
6807-01	03 00 00	3a	Reinforcement Bar	9/29/2025	\$ 16,040.00	\$ -	\$ 16,040.00	11/18/2025	\$ 16,040.00	\$ -
50033541845	03 00 00		Waterstop	9/24/2025	\$ 1,224.00	\$ -	\$ 1,224.00		\$ 1,224.00	\$ -
31830	05 50 00	4.a	Misc Metals	9/19/2025	\$ 11,200.00	\$ -	\$ 11,200.00		\$ -	\$ 11,200.00
33321	05 50 00	4.a	Misc Metals	3/18/2026	\$ 80,149.00	\$ -	\$ 80,149.00		\$ -	\$ 80,149.00
32321	05 00 00	6b	Door Jamb and Grating Embeds	11/19/2025	\$ 7,706.00	\$ -	\$ 7,706.00		\$ -	\$ 7,706.00
48482	23 00 00	11c	EF-1 Fan	12/1/2025	\$ 1,925.30	\$ -	\$ 1,925.30		\$ -	\$ 1,925.30
48418	23 00 00	11c	Electrical Unit Heaters	12/1/2025	\$ 4,557.80	\$ -	\$ 4,557.80		\$ -	\$ 4,557.80
48646	23 00 00	11a	Louver and Damper	12/1/2025	\$ 2,974.40	\$ -	\$ 2,974.40		\$ -	\$ 2,974.40
S0111147504.001	26 00 00	12a	Electrical Conduits and Accessories	7/1/2025	\$ 12,895.00	\$ -	\$ 12,895.00	10/20/2025	\$ 4,035.00	\$ 8,860.00
124718	26 00 00	12a	PVC Conduits and Panel Boards	10/20/2025	\$ 5,929.30	\$ -	\$ 5,929.30	10/20/2025	\$ 965.00	\$ 4,964.30
124588	26 00 00	12c	Electrical Gear and Fixtures	9/19/2025	\$ 14,920.35	\$ -	\$ 14,920.35		\$ -	\$ 14,920.35
124938	26 00 00	12c	Gear and other accessories	12/17/2025	\$ 13,910.43	\$ -	\$ 13,910.43	12/17/2025	\$ 1,301.54	\$ 12,608.89
13360	26 00 00	12e	Electrical Controls Equipment/HOA	2/10/2026	\$ 36,810.88	\$ -	\$ 36,810.88		\$ -	\$ 36,810.88
91971	31 00 00		Pipe Bedding	9/3/2025	\$ 2,801.03	\$ -	\$ 2,801.03	9/30/2025	\$ 2,801.03	\$ -
91832	31 00 00		Pipe Bedding	8/27/2025	\$ 2,765.63	\$ -	\$ 2,765.63	9/30/2025	\$ 2,765.63	\$ -
1B 51623	33 14 16		Foundation Rock for Pipe Bedding	9/23/2025	\$ 770.00	\$ -	\$ 770.00	9/30/2025	\$ 770.00	\$ -
93006	33 14 16		Foundation Rock for Pipe Bedding	10/8/2025	\$ 843.70	\$ -	\$ 843.70	10/8/2025	\$ 843.70	\$ -
112481 01	33 14 16	15a	Underground Piping	8/1/2025	\$ 83,478.97	\$ -	\$ 83,478.97		\$ 21,399.91	\$ 62,079.06
112481 02	33 14 16	15a	Underground Piping	8/20/2025	\$ 29,211.84	\$ -	\$ 29,211.84		\$ -	\$ 29,211.84
112481 03	33 14 16	15a	Underground Piping	9/10/2025	\$ 798.99	\$ -	\$ 798.99	9/30/2025	\$ 798.99	\$ -
114342 01	33 14 16	15a	Underground Piping	9/10/2025	\$ 454.51	\$ -	\$ 454.51	9/30/2025	\$ 454.51	\$ -
114630 01	33 14 16	15a	Underground Piping	9/18/2025	\$ 248.59	\$ -	\$ 248.59	9/30/2025	\$ 248.59	\$ -
112481 04	33 14 16	15a	Underground Piping	9/22/2025	\$ 6,914.70	\$ -	\$ 6,914.70		\$ -	\$ 6,914.70
117125 01	40 05 00		Wall Collar Pipe in the Splitter Box	1/8/2026	\$ 1,385.00	\$ -	\$ 1,385.00	1/15/2026	\$ 1,385.00	\$ -
115048	33 14 16		Gate Valve Accessories	10/3/2025	\$ 656.95	\$ -	\$ 656.95	10/8/2025	\$ 656.95	\$ -
250403AP4-1	33 14 19	15d	Gate Valve & Check Valve	10/6/2025	\$ 5,522.99	\$ -	\$ 5,522.99	10/8/2025	\$ 2,727.19	\$ 2,795.80
250403AP4-2	40 05 65.23	15d	Swing Check Valve	10/30/2025	\$ 725.41	\$ -	\$ 725.41		\$ -	\$ 725.41
250403AP4-3	40 05 00	15d	Plug Valves	2/27/2026	\$ 24,226.46	\$ -	\$ 24,226.46		\$ -	\$ 24,226.46

14827	40 05 00	15d	Stainless Steel Piping	2/10/2026	\$ 18,800.00	\$ -	\$ 18,800.00		\$ -	\$ 18,800.00
23736	40 05 00	15h	Slide Gates	2/24/2026	\$ 50,500.00	\$ -	\$ 50,500.00		\$ 30,300.00	\$ 20,200.00
47244B44510	43 00 00	16a	Grundfos ERW Pump	11/1/2025	\$ 20,914.00	\$ -	\$ 20,914.00		\$ 20,914.00	\$ -
					\$ -	\$ -	\$ -		\$ -	\$ -
			<b>Totals</b>		\$ 487,581.23	\$ -	\$ 487,581.23		\$ 135,951.04	\$ 351,630.19

**APPLICATION AND CERTIFICATION FOR PAYMENT**

AIA DOCUMENT G702

TO OWNER: PROJECT: APPLICATION NO: 14  
 Beatrice Area Solid Waste Agency BASWA South MSW Landfill  
 400 Ella Street Site Entrance Facility  
 Beatrice, NE 68310  
 FROM CONTRACTOR: VIA ENGINEER: PERIOD TO: 5/31/2026  
 Genesis Contracting Group Burns & McDonnell APPLICATION DATE: 6/3/2026  
 404 Hill Street 6909 South Lyncrest Place - Suite 120  
 Lincoln NE. 68502 Sioux Falls, SD 57108  
 CONTRACT FOR: New Construction CONTRACT DATE: January 6, 2025

Distribution to:

OWNER

CONSTRUCTION MANAGER

ARCHITECT/ENGINEER

CONTRACTOR

**CONTRACTOR'S APPLICATION FOR PAYMENT**

Application is made for payment, as shown below, in connection with the Contract. Continuation Sheet, AIA Document G703, is attached.

1. ORIGINAL CONTRACT SUM	\$	<u>4,052,000.00</u>
2. Net change by Change Orders	\$	<u>4,917.22</u>
3. CONTRACT SUM TO DATE (Line 1 ± 2)	\$	<u>4,056,917.22</u>
4. TOTAL COMPLETED & STORED TO DATE (Column G on G703)	\$	<u>4,056,917.22</u>
5. RETAINAGE:		
a. 0 % of Completed Work (Column D + E on G703)	\$	<u>0.00</u>
b. 0 % of Stored Material (Column F on G703)	\$	<u>                    </u>
Total Retainage (Lines 5a + 5b or Total in Column I of G703)	\$	<u>0.00</u>
6. TOTAL EARNED LESS RETAINAGE (Line 4 Less Line 5 Total)	\$	<u>4,056,917.22</u>
7. LESS PREVIOUS CERTIFICATES FOR PAYMENT (Line 6 from prior Certificate)	\$	<u>4,016,348.05</u>
8. CURRENT PAYMENT DUE	\$	<u>40,569.17</u>
9. BALANCE TO FINISH, INCLUDING RETAINAGE (Line 3 less Line 6)	\$	<u>0.00</u>

CHANGE ORDER SUMMARY	ADDITIONS	DEDUCTIONS
Total changes approved in previous months by Owner	\$4,917.22	\$0.00
Total approved this Month	\$0.00	\$0.00
TOTALS	\$4,917.22	\$0.00
NET CHANGES by Change Order		\$4,917.22

The undersigned Contractor certifies that to the best of the Contractor's knowledge, information and belief the Work covered by this Application for Payment has been completed in accordance with the Contract Documents, that all amounts have been paid by the Contractor for Work for which previous Certificates for Payment were issued and payments received from the Owner, and that current payment shown herein is now due.  
 CONTRACTOR: Genesis Contracting Group LLC.

By: [Signature] Date: 6/3/2026  
 State of: Nebraska County of: Lancaster  
 Subscribed and sworn to before me this 3rd day of June 2026  
 Notary Public: Rebecca Petrzilka  
 My Commission expires: 09-30-29

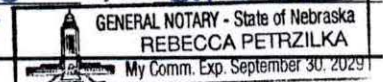

**CERTIFICATE FOR PAYMENT**

In accordance with the Contract Documents, based on on-site observations and the data comprising this application, the Construction Manager and Architect certify to the Owner that to the best of their knowledge, information and belief the Work has progressed as indicated, quality of the Work is in accordance with the Contract Documents, and the Contractor is entitled to payment of the AMOUNT CERTIFIED.

AMOUNT CERTIFIED ..... \$ 40,569.17

(Attach explanation if amount certified differs from the amount applied for. Initial all figures on this Application and on the Continuation Sheet that changed to conform to the amount certified.)

ARCHITECT: [Signature] Date: 6/03/2026  
 By: [Signature] Date: 6/03/2026  
 This Certificate is not negotiable. The AMOUNT CERTIFIED is payable only to the Contractor named herein. Issuance, payment and acceptance of payment are without prejudice to any rights of the Owner or Contractor under this Contract.

G703 Document

APPLICATION NO: 14

APPLICATION DATE: 6/3/2026

PERIOD TO: 5/31/2026

DESCRIPTION OF WORK	Current SCHEDULED VALUE	WORK COMPLETED THIS APPLICATION		WIP THIS PERIOD PLUS STORED	TOTAL COMPLETED AND STORED TO DATE	RETAINAGE THIS PERIOD	NET AMOUNT DUE THIS PERIOD	%	BALANCE TO FINISH	RETAINAGE	
		PREVIOUS APPLICATIONS	THIS APPLICATION								
			Work In Place								STORED MATERIAL
General Conditions	205,000.00	205,000.00	0.00	0.00	0.00	205,000.00	0.00	0.00	100.00%	0.00	0.00
Bond and Insurance	85,000.00	85,000.00	0.00	0.00	0.00	85,000.00	0.00	0.00	100.00%	0.00	0.00
Site Excavation and Grading	520,000.00	520,000.00	0.00	0.00	0.00	520,000.00	0.00	0.00	100.00%	0.00	0.00
Site Fencing	25,000.00	25,000.00	0.00	0.00	0.00	25,000.00	0.00	0.00	100.00%	0.00	0.00
Landscaping/Seeding	45,000.00	45,000.00	0.00	0.00	0.00	45,000.00	0.00	0.00	100.00%	0.00	0.00
Reinforcement	60,000.00	60,000.00	0.00	0.00	0.00	60,000.00	0.00	0.00	100.00%	0.00	0.00
Foundation	175,000.00	175,000.00	0.00	0.00	0.00	175,000.00	0.00	0.00	100.00%	0.00	0.00
Slab on Grade	180,000.00	180,000.00	0.00	0.00	0.00	180,000.00	0.00	0.00	100.00%	0.00	0.00
Site Paving	350,000.00	350,000.00	0.00	0.00	0.00	350,000.00	0.00	0.00	100.00%	0.00	0.00
Miscellaneous Steel	50,000.00	50,000.00	0.00	0.00	0.00	50,000.00	0.00	0.00	100.00%	0.00	0.00
Steel Erection	9,000.00	9,000.00	0.00	0.00	0.00	9,000.00	0.00	0.00	100.00%	0.00	0.00
Rough Carpentry	10,000.00	10,000.00	0.00	0.00	0.00	10,000.00	0.00	0.00	100.00%	0.00	0.00
Finish Carpentry	8,500.00	8,500.00	0.00	0.00	0.00	8,500.00	0.00	0.00	100.00%	0.00	0.00
Casework	9,000.00	9,000.00	0.00	0.00	0.00	9,000.00	0.00	0.00	100.00%	0.00	0.00
Countertops	15,000.00	15,000.00	0.00	0.00	0.00	15,000.00	0.00	0.00	100.00%	0.00	0.00
Metal Stud Framing and GWB	110,000.00	110,000.00	0.00	0.00	0.00	110,000.00	0.00	0.00	100.00%	0.00	0.00
Frames Doors and Hardware	41,000.00	41,000.00	0.00	0.00	0.00	41,000.00	0.00	0.00	100.00%	0.00	0.00
Aluminum Frames and Glazing	65,000.00	65,000.00	0.00	0.00	0.00	65,000.00	0.00	0.00	100.00%	0.00	0.00
Overhead Door	47,000.00	47,000.00	0.00	0.00	0.00	47,000.00	0.00	0.00	100.00%	0.00	0.00
Acoustical Ceilings	6,500.00	6,500.00	0.00	0.00	0.00	6,500.00	0.00	0.00	100.00%	0.00	0.00
Tiling	10,000.00	10,000.00	0.00	0.00	0.00	10,000.00	0.00	0.00	100.00%	0.00	0.00
Flooring	5,000.00	5,000.00	0.00	0.00	0.00	5,000.00	0.00	0.00	100.00%	0.00	0.00
Painting	26,000.00	26,000.00	0.00	0.00	0.00	26,000.00	0.00	0.00	100.00%	0.00	0.00
Concrete Floor Finishes	25,000.00	25,000.00	0.00	0.00	0.00	25,000.00	0.00	0.00	100.00%	0.00	0.00
Specialties	8,000.00	8,000.00	0.00	0.00	0.00	8,000.00	0.00	0.00	100.00%	0.00	0.00
Fuel Tank	25,000.00	25,000.00	0.00	0.00	0.00	25,000.00	0.00	0.00	100.00%	0.00	0.00
Storm Shelter	12,000.00	12,000.00	0.00	0.00	0.00	12,000.00	0.00	0.00	100.00%	0.00	0.00
Scale	490,000.00	490,000.00	0.00	0.00	0.00	490,000.00	0.00	0.00	100.00%	0.00	0.00
Roof Accessories	6,000.00	6,000.00	0.00	0.00	0.00	6,000.00	0.00	0.00	100.00%	0.00	0.00
Insulated Metal Panels	300,000.00	300,000.00	0.00	0.00	0.00	300,000.00	0.00	0.00	100.00%	0.00	0.00
PEMB Materials	220,000.00	220,000.00	0.00	0.00	0.00	220,000.00	0.00	0.00	100.00%	0.00	0.00
PEMB Erection	189,000.00	189,000.00	0.00	0.00	0.00	189,000.00	0.00	0.00	100.00%	0.00	0.00
Site Utilities	70,000.00	70,000.00	0.00	0.00	0.00	70,000.00	0.00	0.00	100.00%	0.00	0.00
Plumbing	235,000.00	235,000.00	0.00	0.00	0.00	235,000.00	0.00	0.00	100.00%	0.00	0.00
HVAC	150,000.00	150,000.00	0.00	0.00	0.00	150,000.00	0.00	0.00	100.00%	0.00	0.00
Electrical	265,000.00	265,000.00	0.00	0.00	0.00	265,000.00	0.00	0.00	100.00%	0.00	0.00
Change Order #001	4,917.22	4,917.22	0.00	0.00	0.00	4,917.22	0.00	0.00	100.00%	0.00	0.00

G703 Document

APPLICATION NO: 14

APPLICATION DATE: 6/3/2026

PERIOD TO: 5/31/2026

DESCRIPTION OF WORK	Current SCHEDULED VALUE	WORK COMPLETED			WIP THIS PERIOD PLUS STORED	TOTAL COMPLETED AND STORED TO DATE	RETAINAGE THIS PERIOD	NET AMOUNT DUE THIS PERIOD	%	BALANCE TO FINISH	RETAINAGE
		PREVIOUS APPLICATIONS	Work In Place	STORED MATERIAL							
<b>GRANDTOTAL:</b>	4,056,917.22	4,056,917.22	0.00	0.00	0.00	4,056,917.22	0.00	0.00	100.00%	0.00	40,569.17

**RESOLUTION NUMBER \_\_\_\_**

**WHEREAS**, Gage Development Coalition will be hosting the Homestead Days Parade on Saturday, June 27, 2026; and

**WHEREAS**, Gage Development Coalition has requested that Court Street be closed from 3<sup>rd</sup> Street to 19<sup>th</sup> Street, between 8:00 a.m. and 12:30 p.m.; and

**WHEREAS**, Court Street is also Highway 136; and

**WHEREAS**, closure of a State Highway for a special event requires notification to the Nebraska Department of Transportation and the City's agreement to indemnify the State.

NOW, THEREFORE, BE IT RESOLVED BY THE MAYOR AND CITY COUNCIL OF THE CITY OF BEATRICE, NEBRASKA:

**SECTION 1.** That the Beatrice City Council desires to allow Gage Development Coalition to utilize Court Street, from 3<sup>rd</sup> Street to 19<sup>th</sup> Street, between 8:00 a.m. and 12:30 p.m. on Saturday, June 27, 2026, for the Homestead Days Parade.

**SECTION 2.** That said portion of Court Street is located within the official corporate limits of the City of Beatrice.

**SECTION 3.** That the City of Beatrice acknowledges and accepts the duties set out in Neb. Rev. Stat. §39-1359(2)(d) and, if a claim is made against the State, shall indemnify, defend, and hold harmless the State from all claims, demands, actions, damages, and liability, including reasonable attorney's fees, that may arise as a result of the special event.

**SECTION 4.** That all resolutions or parts of resolutions in conflict herewith are hereby repealed.

RESOLUTION PASSED AND ADOPTED this 15<sup>th</sup> day of June, 2026.

Attest:

\_\_\_\_\_  
Erin Saathoff, MMC, City Clerk

\_\_\_\_\_  
Robert Morgan, Mayor



Gage Development Coalition  
218 N 5th St.  
Beatrice, NE 68310  
director@gagedevco.org  
2 June 2026

---

City of Beatrice  
Tobias Tempelmeyer  
400 Ella Street  
Beatrice, NE 68310

**Re: Use of Public Properties**

Dear Tobias,

The Gage Development Coalition respectfully requests the use of public property and the ability to sell goods and services for Homestead Days®, June 24-28, 2026. In detail we request the following for family-friendly activities and events:

- Thursday, June 25, 5 – 8 pm: Beatrice Water Park
- Friday, June 26, 5 - 7:30 pm: 5th Street between Court St. and Ella St.
- Saturday, June 27: Charles Park and the closing of 5th Street between High and Ella, and the alley to the south of the Carnegie Building and the parking lot between the Carnegie Building, 218 N 5th Street, and Uhl's Sporting Goods, 204 N 5th Street, 4th Street between Ella and the the alley between the city offices and Beatrice Middle School
- Friday, Saturday and Sunday, June 26-28: Chautauqua Park
- Friday, Saturday and Sunday, June 26-28: 4th Street between Court and High Streets, as a backup location for JayHusker Swap Meet, should Chautauqua Park be flooded during Homestead Days®, we will be hosting family-centered activities, vendors, and more!

The JayHuskies will be hosting their annual flea market/ swap meet and the Car Show in Chautauqua Park throughout the weekend. At Beatrice Water Park, we would like to continue our partnership with the City of Beatrice to host a free swim on Thursday evening, this year offering the activity to families.



**GAGE**  
DEVELOPMENT  
COALITION

Gage Development Coalition  
218 N 5th St.  
Beatrice, NE 68310  
director@gagedevco.org  
2 June 2026

---

Our complete schedule will be included on a separate document, and we will be happy to share the schedule with you. After we have approval for Homestead Days®, I would also like to host a meeting with you and City department managers at a time convenient for you to allow communication on details and logistics. We appreciate all the contributions the City makes to ensure the success of Homestead Days® and thank you in advance for your continued support.

Sincerely,

Caleb Fjone  
Executive Director  
Gage Development Coalition

## **NOTICE OF HEARING**

Notice is hereby given that Dakuhl Investments, LLC, dba, Vinny's Alchemy & Spirits, 205 North 19<sup>th</sup> Street, Beatrice, Nebraska, has submitted a new application for a Class C liquor license.

Public Hearing on said application will be held in the Board Room located in the BPS Administration Building Board Room, 320 North 5<sup>th</sup> Street, Beatrice, Nebraska on Monday, June 15, 2026, at 6:00 p.m. Any person or persons desiring to submit evidence, under oath, either orally or by affidavit, bearing upon the propriety of the issuance of such a license to the above applicant may appear at the hearing on the time and place above specified.

Erin Saathoff, MMC, City Clerk

June 5, 2026



# Nebraska Liquor Control

301 Centennial Mall  
South - 1st Floor PO  
Box 95046 Lincoln  
NE 68508

## Application Copy

File Number: 173012

LICENSE TYPE Class C Beer, Wine, Spirits On and Off Sale	APPLICATION DATE RECEIVED 2026-05-09
SECONDARY LICENSE(S) None selected	
LICENSEE LEGAL NAME Dakuhl Investments LLC	LICENSEE TYPE Corporation
DOING BUSINESS AS Vinny's Alchemy & Spirits	CORPORATE NUMBER
INCORPORATION DATE 2026-04-30	
CORRESPONDENCE ADDRESS 205 N 19th St Beatrice, NE 68310	
MAILING ADDRESS 205 N 19th St Beatrice, NE 68130	
PHYSICAL ADDRESS 205 N 19th St Beatrice, NE 68130	
CONTACT NAME Tamra D'Andrea	PREFERRED CONTACT METHOD Email
CONTACT PHONE (402) 520-2603	ALTERNATE PHONE (402) 239-8664

FAX

EMAIL

vinnys.alchemy.spirits@gmail.com

CORPORATE STRUCTURE

NAME	POSITION/TITLE	PARENT COMPANY	% INTEREST
Tamra D'Andrea	President	Dakuhl Investments LLC	49
Vincenzo D'Andrea	Manager/Operator	Dakuhl Investments LLC	51

ADDITIONAL INFORMATION

Temporary Operating Permit

LICENSE

License 153851 (Active) - Class C Beer, Wine, Spirits On and Off Sale (Nov 01, 2025 - Oct 31, 2026)  
Sip & Spa (Good Liv'in LLC)

MARITAL STATUS

Single

MANAGED BY AGENT

No

PREMISES TYPE

Bar/Lounge (on prem)

PREMISES NAME

Vinny's Alchemy & Spirits

OPERATOR

Vincenzo D'Andrea

CORPORATE LIMIT DESIGNATION

Inside

LEASE OR OWN

Own

PHYSICAL ADDRESS

205 N 19th St  
Beatrice, NE 68310

MAILING ADDRESS

CONTACT NAME Tamra D'Andrea	PREFERRED CONTACT METHOD Email
CONTACT PHONE (402) 520-2603	ALTERNATE PHONE (402) 239-8664
FAX	EMAIL vinnys.alchemy.spirits@gmail.com
PREMISES MANAGER Vincenzo D'Andrea	PREMISES MANAGER EMAIL vinnys.alchemy.spirits@gmail.com

QUESTIONS

**Class C Beer, Wine, Spirits On a**

1. READ CAREFULLY. ANSWER COMPLETELY AND ACCURATELY

Has any officer, member, owner, or manager named in this application; or their spouse, EVER been convicted of or plead guilty to any charge?

\*The Commission must be notified of any arrests and/or convictions that may occur after the date of this application.

Yes

(document uploaded)

2. What are the building dimensions: Enter length and width in feet separated by a comma (i.e. L20, W15) \*Not square feet\*

A simple sketch of the area to be licensed will be required to be uploaded in the Documents Section.. Include the length x width, direction of NORTH and number of floors of the building. (NO BLUEPRINTS)

L62, W62

3. Is there an outdoor area?

\*Permanent fence or barrier is required for outdoor areas. Please contact the local governing body for other requirements regarding fencing.

No

4. Will a basement be used for alcoholic storage or sale?

No

5. How many floors of the building? (excluding basement) Please indicate which floors will be included in the liquor license.

1

6. Is premises to be licensed within 150 feet of a church, school, hospital, home for indigent persons or for veterans, their wives, and children?

No

7. Is premises to be licensed within 300 feet of a college campus or university?

No

8. Are you acquiring any alcohol prior to obtaining this liquor license? If you are purchasing a business with a current license; this includes alcohol purchased as part of a business purchase agreement.

Yes

(document uploaded)

9. What date do you intend to open for business?

6/1/2026

10. What are the anticipated hours of operation?

3:00 pm - midnight Tuesday - Thursday; 3:00 pm - 2:00 am Friday & Saturday

11. Are you borrowing any money from any source, including family or friends, to establish and/or operate the business?

Yes

Good Liv'in LLC

12. Will any person or entity, other than the applicant, be entitled to a share of the profits of this business?

No

13. Is anyone listed on this application a law enforcement officer?

No

14 What is the primary bank and/or financial institution to be utilized by the business AND list the individual(s) who are authorized to write checks and/or withdrawals on accounts at this institution.

Security First Bank; Tamra and Vincenzo D'Andrea

15 Do you have prior experience or training in selling, serving or managing alcohol sales?

Yes

Fraternal Order of Eagles #531 bartender/asst. manager Vincenzo

16 Are all individuals named in this application as a part of the ownership and/or manager over 21 years of age?

Yes

17 Do you intend to sell cocktails to go as allowed under Neb Rev. Statute 53-123.04(4)?

No

18 Do you intend to allow drive through services (curb side pick up) allowed under Neb Rev. Statute 53-178.01(2)

Yes

19 List all past and present liquor licenses held in Nebraska or any other state by any person named in this application. List the license holder name, location of license, and license number (if available). Also list reason for termination of license(s) previously held.

None

20 Has the premises location been previously licensed within the last 2 years?

Yes

21 Are you applying for a Temporary Operating Permit?

Yes

(document uploaded)

22 Is the lease, deed, or purchase agreement for the premises listed under the applicant's name (LLC, Corporation, or Individual)? If the property is owned personally but the application is under an LLC or Corporation, a lease agreement must be made between the owner and the entity applying for the license.

Yes

23 If applying as a LLC or Corporation; is your LLC or Corporation active with the Nebraska Secretary of State? (Please mark yes if applying as an individual or partnership)

Yes

24 Per Nebraska Revised Statute 53-103.18 - Manager, defined: Manager means a person appointed by a corporation or limited liability company to oversee the daily operation of the business licensed in Nebraska. A manager shall meet all the requirements of the Nebraska Liquor Control Act as though he or she were the applicant, including residency.

What is the premises manager's name?

Vincenzo D'Andrea

25 What is the manager's address?

715 High St, Beatrice, NE 68310

26 What is the manager's phone number?

402-239-8664

27 What county is the manager registered to vote in?

The manager must be a resident of the state of Nebraska. If the manager is not registered to vote they can complete their voter registration here - <https://www.nebraska.gov/apps-sos-voter-registration/>

Gage

28 What is the manager's email address? An email will be sent to them to obtain their personal information.

papazuko@gmail.com

29 Is the manager married?

Yes

Tamra D'Andrea tjk9881@hotmail.com

DOCUMENTS

TYPE	FILE NAME	DESCRIPTION
Alcohol Inventory	Temporary Operating Permit Vinny's Alchemy & Spirits.pdf	
Business Plan	Vinny's Alchemy & Spirits Business Plan.pdf	
Explanation of Convictions/Guilty Pleas	Explanation Conviction T. D'Andrea.pdf	
Explanation of Convictions/Guilty Pleas	Explanation Conviction V. D'Andrea.pdf	
Lease / Deed / Purchase Agreement	NECRE5009_NTC_Deed-Warranty 205 N 19th Beatrice NE.pdf	
Premises Description & Diagram	Building Sketch Vinny's Alchemy & Spirits.pdf	
Privacy Act Statement	Privacy Statement T. D'Andrea.pdf	
Privacy Act Statement	Privacy Statement V. D'Andrea.pdf	
Temporary Operating Permit (TOP)	Temporary Operating Permit Vinny's Alchemy & Spirits.pdf	

APPLICANT

Tamra D'Andrea

## DECLARATION

- I (We) the applicant(s) agree and consent

By checking the box next to "I (We) the applicant(s) agree and consent", the applicant(s) hereby consent(s) to an investigation of background and release present and future records of every kind and description including, but not limited to, police records, tax records, bank or lending institution records, and corporate records. I consent to the release of any documents supporting any declarations made in this application and agree to provide any documents supporting these declarations to the Nebraska Liquor Control Commission (NLCC) or the Nebraska State Patrol (NSP) immediately upon demand. I agree to provide any record needed in furtherance of any investigation related to this application immediately upon demand to the NLCC or the NSP. I waive any right or cause of action that I may have against the NLCC, the NSP, or any other individual or entity disclosing or releasing any investigatory or supporting records related to this application or the review of this application.

I acknowledge that false information submitted in this application is grounds for denial of a license. Any license issued based on the information submitted in this application is subject to additional conditions, cancellation, revocation, or suspension if the information contained herein is incomplete, inaccurate, or fraudulent. I acknowledge that any changes to the information contained in this application must be reported to the NLCC. I acknowledge the review of this application will involve a criminal record check of all owners, partners, managers, officers and stockholders or members owning 25% interest in the applying entity and their spouses. Any license granted by the NLCC is subject to the provisions of the Nebraska Liquor Control Act and the Rules & Regulations of the NLCC, and that failure to comply with these provisions and rules may subject the license to suspension, cancellations, or revocation. I acknowledge that a licensee must keep complete, accurate, and separate records and that a licensee's records and books are subject to inspection by the NLCC. NLCC auditors and law enforcement officers are authorized to enter and inspect the licensed premises at any time to determine whether any provision of the Act, rule or regulation, or ordinance has been or is being violated. I acknowledge that it is the licensee's responsibility to comply with the provisions of the Nebraska Liquor Control Act and the Commission's rules and regulations.

If I am an individual applicant, I will supervise in person the management and operation of the business and operate the business authorized by the license for myself and not as an agency for any other person or entity. If I am a corporate applicant, I will ensure that an approved manager will supervise in person the management and operation of the business. If I am a partnership applicant, I will ensure one partner supervises the management and operation of the business.

I will operate the licensed business in compliance with all applicable laws, rules and regulations, and ordinances and to cooperate fully with any authorized agent of the NLCC.

I declare under penalty of perjury that I have read the contents of this application and, to the best of my knowledge, believe all statements made in this application are true, correct, and complete.

**Applicant Notification and Record Challenge:** An applicant's fingerprints will be used to check the criminal history records of the FBI. The applicant may complete or challenge the accuracy of the information contained in the FBI Identification Record. The procedures for obtaining a change, correction, or updating an FBI identification record are set forth in 28 CFR 16.34.

# APPLICATION FOR TEMPORARY OPERATING PERMIT

NEBRASKA LIQUOR CONTROL COMMISSION  
301 CENTENNIAL MALL SOUTH  
PO BOX 95046  
LINCOLN, NE 68509-5046  
PHONE: (402) 471-2571  
FAX: (402) 471-2814  
website: [www.lcc.nebraska.gov](http://www.lcc.nebraska.gov)

This form must be signed by the Current Licensee (Seller) and the Applicant (Buyer).

A Temporary Operating Permit (TOP) may be issued at the Commission's discretion when a licensed business is sold, and the business continues under new ownership. A complete application for a new license must be filed before a TOP can be granted.

If issued, the Temporary Operating Permit is valid for 90 days. If subsequent reports reveal that the information provided in the application was inaccurate or incomplete, the Temporary Operating Permit may be cancelled.

Name of current licensee (Seller, e.g.. LLC or Corporation): Good Livin LLC

Name of applicant (Buyer; e.g. LLC or Corporation): Dakuhl Investments LLC

On this date 5/2/2026 buyer and seller entered a contract for sale of the alcohol  
(Date)

related business known as: Sip - N - Spa License #: 153851  
(Name of business currently licensed)

Located at:

205 N. 19<sup>TH</sup> St. , Beatrice , NE 68310  
(Street Address) (City) (Zip Code)

Requested effective date of Temporary Operating Permit: June 1<sup>ST</sup> 2026  
(The Seller's license will be terminated on this date) (Date)

*Seller hereby declares that they have no outstanding balances on all accounts with all Nebraska licensed wholesalers under Revised Section 53-123.02. Any seller who provides false information regarding such accounts is guilty of a Class IV misdemeanor for each offense.*

Good Livin, LLC Linda D'Andrea Thomser 5/6/26  
Signature of Seller Printed Name Date  
Good Liv'in LLC Linda D'Andrea Thomser

*Buyer seeks to obtain a Temporary Operating Permit (TOP) to allow buyer to operate the business under the same terms and conditions of the current licensee subject to approval by Nebraska Liquor Control Commission for a period not to exceed 90 days.*

Tamra D'Andrea Tamra D'Andrea 5/6/2026  
Signature of Buyer Printed Name Date  
Dakuhl Investments LLC Dakuhl Investments LLC

## Business Plan: Vinny's Alchemy & Spirits

### Executive Summary

Vinny's Alchemy & Spirits is a boutique bar and retail liquor experience designed to offer a refined yet welcoming environment in a small-town setting. The business blends the comfort of a neighborhood bar with the elevated atmosphere of a curated social space, emphasizing connection, transformation, and memorable experiences.

The concept is rooted in the idea of "alchemy" — transforming ordinary moments into meaningful ones. Rather than relying on heavy theming, the space subtly embodies this philosophy through atmosphere, service, and intentional design.

Vinny's Alchemy & Spirits aims to become a community hub where patrons gather not just to drink, but to connect, unwind, and experience something unexpectedly meaningful.

---

### Business Description

Business Name: Vinny's Alchemy & Spirits

Location: 205 N 19<sup>th</sup> St, Beatrice, NE 68310

Owner: Dakuhl Investments LLC

Business Type: Bar + Retail Liquor Store

Vinny's Alchemy & Spirits will operate as a dual-purpose establishment:

- A bar/lounge offering beer, wine, and crafted cocktails
- A retail liquor store providing packaged alcohol for off-premise consumption

The venue will maintain a clean, modern, and slightly upscale aesthetic while remaining approachable and comfortable. The goal is not exclusivity, but intentional atmosphere — a place where people feel both elevated and at ease.

---

## Mission Statement

To create a space where ordinary moments are transformed into meaningful experiences through atmosphere, connection, and thoughtful service.

---

## Vision Statement

To become a trusted and lasting gathering place in the community—known for its welcoming presence, refined environment, and the ability to turn simple visits into lasting memories.

---

## Core Values

- Connection over consumption – People come first; drinks support the experience.
- Atmosphere matters – The environment shapes the moment.
- Consistency and reliability – Guests know what to expect every time.
- Authenticity – No forced themes; the space speaks naturally.
- Growth through experience – Mistakes are opportunities to improve.

---

## Market Analysis

### Target Market

- Local residents (ages 25–65)
- Working professionals and tradespeople
- Social groups seeking a quieter, more refined alternative to traditional bars
- Community members who value atmosphere and conversation

### Market Need

The local area lacks a venue that blends:

- A clean, modern, and curated environment
- A calm, intimate social atmosphere
- A balance between upscale and approachable

Most existing establishments focus on either:

- High-energy bar environments
- Basic, functional drinking spaces

Vinny's Alchemy & Spirits fills the gap between these extremes.

### Competitive Advantage

- Strong personal reputation of the owner within the community
- Unique atmosphere that is not over-themed or gimmicky
- Dual revenue streams (bar + liquor sales)
- Emphasis on experience rather than volume

---

### Products & Services

#### Bar Offerings

- Beer (domestic and select craft options)
- Wine (curated selection)
- Signature cocktails (including experiential elements such as subtle presentation or transformation)
- Simple, high-quality mixed drinks

#### Retail Liquor Sales

- Bottled spirits
- Wine and beer for off-premise consumption

#### Experience Elements

- Calm, conversational atmosphere

- Occasional specialty drinks or rotating features
- Light visual storytelling through décor and layout

---

## Operations Plan

### Hours of Operation

3:00 pm – Midnight Tuesday through Thursday; 3:00 pm – 2:00 am Friday and Saturday

### Staffing

- Owner/operator (primary presence)
- Bartenders (1–2 per shift depending on volume)
- Minimal staffing model to maintain intimacy and control quality

### Daily Operations

- Maintain clean, organized, and welcoming space
- Provide consistent service and drink quality
- Monitor inventory and sales
- Ensure compliance with all liquor laws and regulations

---

## Management Structure

Vinny's Alchemy & Spirits will be owner-operated, with Vinny D'Andrea overseeing:

- Daily operations
- Staff training and culture
- Customer experience
- Inventory and vendor relationships

This hands-on approach ensures consistency, accountability, and strong customer relationships.

---

## Marketing Strategy

### Brand Positioning

“Vinny’s” leverages the owner’s personal reputation, creating familiarity and trust. The name invites customers in while the atmosphere keeps them returning.

### Marketing Channels

- Word-of-mouth (primary driver in small-town environment)
- Social media presence (Facebook, Instagram)
- Soft opening and community engagement
- Strategic partnerships with local groups and events

### Customer Experience Strategy

- Focus on repeat customers rather than one-time volume
- Create a space where people feel comfortable returning regularly
- Allow the environment to speak rather than over-promoting

---

## Financial Plan

### Revenue Streams

- On-premise alcohol sales (primary)
- Off-premise liquor sales (secondary, steady income)
- Gaming/skill machines

### Startup Costs

- Licensing and permits
- Initial inventory
- Minor renovations and décor adjustments

- Equipment and supplies

#### Profit Strategy

- Maintain controlled overhead
- Focus on consistent, moderate volume rather than high turnover chaos
- Build a loyal customer base

---

#### Licensing & Compliance

Vinny's Alchemy & Spirits will fully comply with all local and state liquor laws, including:

- Age verification procedures
- Responsible serving practices
- Proper licensing for both on-premise and off-premise alcohol sales

Staff will be trained in responsible alcohol service and compliance requirements.

---

#### Risk Assessment

##### Potential Risks

- Small-town market resistance to new concepts
- Initial uncertainty in customer volume
- Regulatory requirements and compliance

##### Mitigation Strategies

- Leverage strong community relationships
- Maintain flexibility in operations
- Focus on consistent quality and experience
- Start controlled and scale naturally

---

## Conclusion

Vinny's Alchemy & Spirits is not just a bar—it is a thoughtfully created environment designed to foster connection, comfort, and memorable experiences.

By combining a strong personal brand, a clear vision, and a balanced operational approach, the business is positioned to become a sustainable and valued part of the community.

The goal is simple but powerful:

To create a place people didn't know they needed—until they walk through the door.

⊕ 1 FLOOR PLAN WITH DIMENSIONS  
SCALE: 1/8" = 1'-0"

62' E

24' S

M 16'S

9' S

M 9'

26' S

M 42' W

42' N

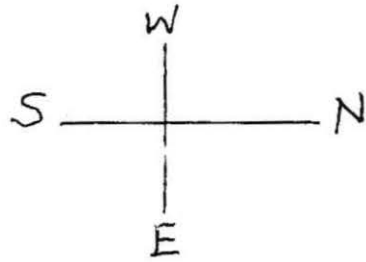

1 Floor



Date: 6/1/2024  
Page: 2  
Revision: 1.0

Location:  
205 N 19TH STREET  
BEATRICE, NEBRASKA 68310

Legal:  
0.4 6 E 35' LOT 19 ALL LOT 20 BLK 7  
LAMB PLACE





**CITY HALL**

400 Ella Street | Beatrice, NE 68310  
Phone: 402.228.5200 Fax: 402.228.2312

**ENGINEERING & COMMUNITY DEVELOPMENT**

205 North 4<sup>th</sup> Street | Beatrice, NE 68310  
Phone: 402.228.5250 Fax: 402.228.5252

## Planning and Zoning Report for Liquor License Application

May 14, 2026

Within the Corporate Limits of the Municipality: Yes ( X ) No ( )

Establishment: Vinny's Alchemy & Spirits

Applicant: Dakuhl Investments, LLC

Address: 205 North 19<sup>th</sup> Street, Beatrice, Nebraska

Legal Description: The East 35 feet of Lot 19 and all of Lot 20, Block 7, Lamb Place, an Addition to Beatrice, Gage County, Nebraska

Requested License or Action: Class C; beer, wine, distilled spirits, on and off sale. No to go, Drive through (curb side pick-up) , YES

Annexation Date: N/A

Ordinance Number: N/A

Existing Zoning: Light Commercial (LC)

Existing Land Use: Medical Office (LC)

Adjacent Zoning and Land Use:

North: Residential: LC,RC,R-3:Personal Services, Medical Office.

East: Residential; R-2

West: Residential: R-3

South: General Commercial: Kennel, Automotive and Equipment Sales, Veterinary Services, Financial Services, Restaurant/bar

General Neighborhood/Area Land Uses: Single Family Residences, Barber shop, Physical Therapy offices, Bank, Dog boarding kennel, Trailer sales, Restaurant/bar.

Analysis of Neighborhood Effects: No foreseeable negative effects. There is currently an establishment in the area which serves food and alcohol. The previous owner held a liquor license.

Additional Comments: None

Prepared by:

Chet McGrury  
Community Development Director

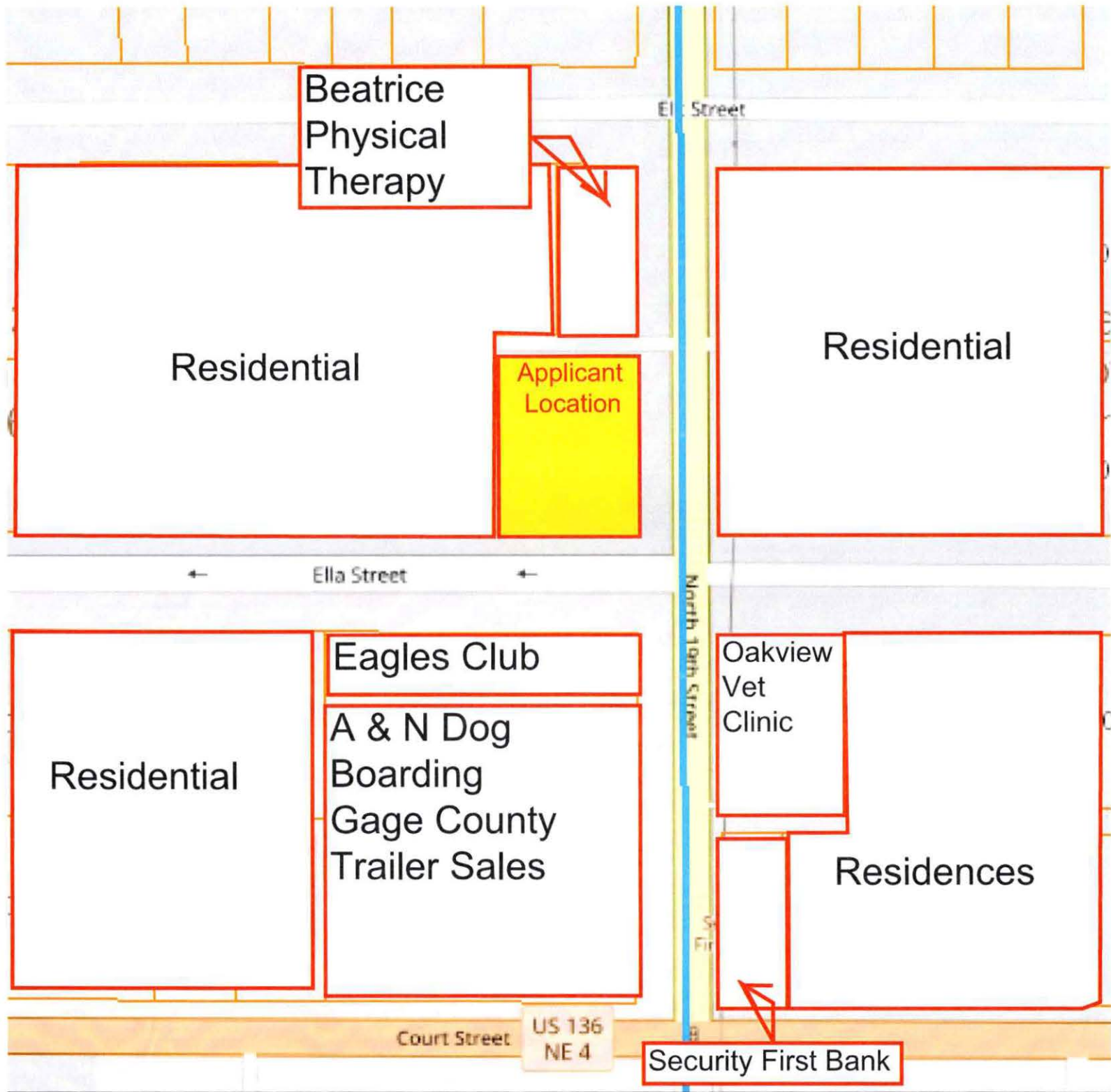

Beatrice  
Physical  
Therapy

Ella Street

Residential

Applicant  
Location

Residential

Ella Street

North 10th Street

Residential

Eagles Club

A & N Dog  
Boarding  
Gage County  
Trailer Sales

Oakview  
Vet  
Clinic

Residences

Court Street US 136  
NE 4

Security First Bank

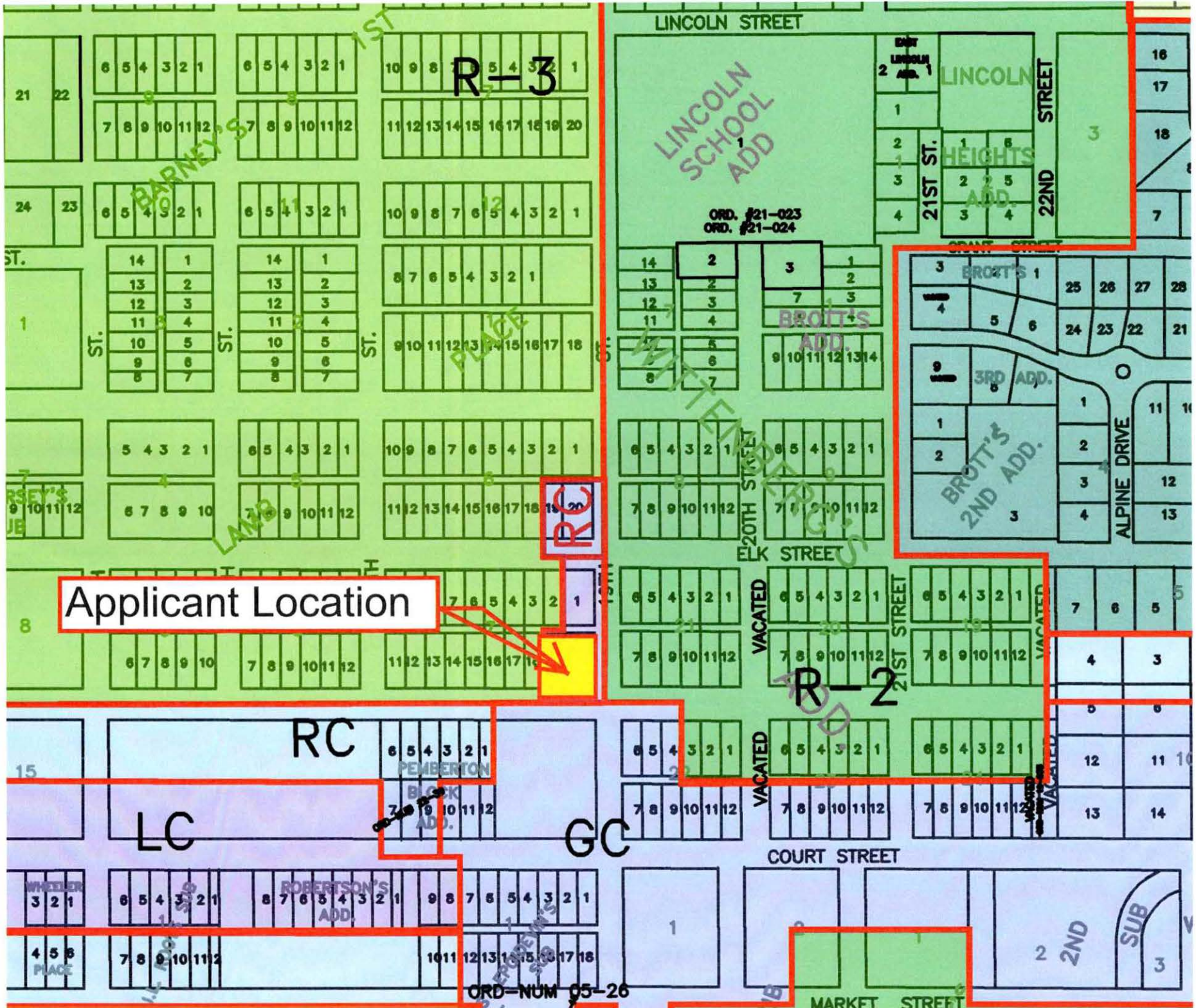

Applicant Location

RC

R-2

RC

LC

GC

ORD-NUM 05-26



**STAKE  
YOUR  
CLAIM**

**BEATRICE**  
CITY • BOARD OF PUBLIC WORKS

**CITY HALL**

400 Ella Street | Beatrice, NE 68310  
Phone: 402.228.5200 Fax: 402.228.2312

**BEATRICE POLICE DEPARTMENT**

201 North 5<sup>th</sup> Street | Beatrice, NE 68310  
Phone: 402.223.4080 Fax: 402.228.3765

May 14<sup>th</sup>, 2026

Mayor Robert Morgan  
Beatrice City Council  
400 Ella Street  
Beatrice, NE 68310

Dear Mayor and City Council:

In reference to the Class C Liquor License filed with the Nebraska Liquor Control Commission by Dakuhl Enterprises dba Vinny's Alchemy and Spirits at 205 North 19<sup>th</sup> Street, I have reviewed the application and completed the background investigation on the applicants, Vincenzo and Tamra D'Andrea. Please be advised that the background investigation revealed nothing which would prohibit the issuance of the Class C Liquor License .

Sincerely,

Sgt. Erin Byrne #322  
Beatrice Police Department



## AGENDA ITEM

**Subject:** Resolution executing the Deliverable Capacity Transaction Agreement with the City of Superior, as recommended by the Board of Public Works

**For Agenda of:** June 15, 2026

**Exhibit(s):**

**Date Submitted:** June 10, 2026

**Recommend a resolution executing the Deliverable Capacity Transaction Agreement with the City of Superior, Nebraska, to provide the City of Beatrice deliverable capacity for the Winter 2026-2027 season, to the Mayor and City Council**

Tobias J. Tempelmeyer, City Administrator/General Manager, reported to the Board due to the increase in winter capacity by Southwest Power Pool's (SPP), the City needs to purchase additional capacity for this winter. This agreement is for the City of Superior to provide Beatrice with the additional capacity. Tempelmeyer stated the price per megawatt has doubled since the City entered into the contract with NextEra. Boardmember Hartley asked for clarification that the additional capacity is required even if it is not used and Tempelmeyer stated that was correct. Boardmember Zarybnicky inquired how many other companies have additional capacity. Tempelmeyer stated he was unsure, however, John Krajewski of JK Energy, knew Superior had additional capacity and Beatrice needed additional capacity, and assisted with the agreement.

Moved by Hartley, seconded by Trauernicht, that the Mayor and City Council execute the Deliverable Capacity Transaction Agreement with the City of Superior, Nebraska, to provide the City of Beatrice deliverable capacity for the Winter 2026-2027 season.

Roll Call: Yea: Baehr, Hartley, Jones, Trauernicht, Zarybnicky  
Nay: None

MOTION CARRIED.

**RESOLUTION NUMBER \_\_\_\_\_**

A resolution authorizing the Mayor and City Clerk to enter into a Deliverable Capacity Transaction Agreement with the City of Superior, Nebraska, to provide the City of Beatrice, Nebraska deliverable capacity for the Winter 2026-2027 season.

NOW, THEREFORE, BE IT RESOLVED BY THE MAYOR AND CITY COUNCIL OF THE CITY OF BEATRICE, NEBRASKA:

**SECTION 1.** That the Mayor and City Clerk are hereby authorized to execute the Deliverable Capacity Transaction Agreement with the City of Superior, Nebraska, to provide the City of Beatrice, Nebraska deliverable capacity for the Winter 2026-2027 season. A copy of the said Deliverable Capacity Transaction Agreement, marked as Exhibit "A", is attached hereto and incorporated by reference.

**SECTION 2.** That all resolutions or parts of resolutions in conflict herewith are hereby repealed.

RESOLUTION PASSED AND ADOPTED this 15<sup>th</sup> day of June, 2026.

Attest:

\_\_\_\_\_  
Erin Saathoff, MMC, City Clerk

\_\_\_\_\_  
Robert Morgan, Mayor

Exhibit "A"

**DELIVERABLE CAPACITY TRANSACTION  
CONFIRMATION LETTER**

This confirmation letter ("Confirmation Letter" or "Agreement") shall confirm the transaction ("Transaction") agreed to on the "Trade Date" below, between the City of Superior, Nebraska ("Superior" or "Seller") and the City of Beatrice, Nebraska ("Beatrice" or "Buyer"). Superior and Beatrice may be referred to herein individually as "Party" and collectively as "Parties."

Capitalized terms used but not defined herein shall have the meanings ascribed to them in the Governing Terms or the SPP Documents, as applicable.

The terms and conditions of the Transaction are as follows:

Trade Date: June 15, 2026

Buyer: City of Beatrice, Nebraska

Seller: City of Superior, Nebraska

Term: December 1, 2026 through March 31, 2027 (SPP Winter Resource Adequacy Season).

Generation Resource: Don Henry Power Center, purchased from NextEra Energy Marketing under an Agreement dated October 24, 2023.

Products: Deliverable Capacity: Deliverable Capacity as defined in Attachment AA of the OATT. Deliverable Capacity shall be sourced from the Generation Resource. Seller shall be obligated to sell and deliver, and Buyer shall be obligated to purchase and receive Deliverable Capacity in an amount equal to the Contract Quantity. Buyer and Seller acknowledge and agree that Deliverable Capacity shall not include any planning reserves. Further, Parties acknowledge that firm transmission service is not required for Deliverable Capacity and that Buyer will not be requesting firm transmission service.

"SPP Documents" means (i) the Southwest Power Pool ("SPP") Open Access Transmission Tariff ("OATT") as filed with the Federal Energy Regulatory Commission ("FERC") and as amended from time to time; (ii) the SPP Planning Criteria, effective February 10, 2026, as amended from time to time ("SPP Planning Criteria"); and (iii) any business practices and market protocols established or

implemented by SPP, as amended from time to time, *provided that* in the event of any inconsistency in the SPP Documents, the OATT shall at all times prevail.

Contract Quantity: MW, or kW

Contract Price: \$ per month, based on a rate of \$ per kW-month applied to Contract Quantity

Delivery Point: Not applicable to Deliverable Capacity.

Scheduling: The Generation Resource is offered into the SPP Integrated Marketplace in accordance with the SPP Documents by its owner, Hastings Utilities. Buyer acknowledges that Buyer has no right to actual commitment or dispatch of the Generation Resource.

Payments: Billing and payment for Deliverable Capacity shall occur on a monthly basis within ten (10) days of the conclusion of each month during which this Agreement is effective. Payment will be due within twenty (20) days of the date on which the invoice is issued. Interest on past due amounts will accrue at a rate of twelve percent (12%) per annum, compounded monthly.

Change in SPP Documents:

If FERC or other applicable regulatory body shall implement any change in law, rule, regulation, tariff or practice that materially and adversely affects Seller's or Buyer's ability to perform its obligations hereunder, the Parties shall negotiate in good faith an amendment to this Confirmation Letter or take other appropriate action the effect of which is to restore each Party, as closely as possible, to its same position as prior to such change.

Compliance with SPP Documents:

The Parties acknowledge and agree that Seller shall not be responsible for Buyer's compliance with any SPP Planning Criteria or the OATT. Buyer acknowledges that Seller is not Buyer's Load Responsible Entity ("LRE") as defined in Attachment AA to the OATT and that Buyer or another SPP Market Participant is the LRE for Buyer.

Governing Terms: This Confirmation Letter is subject to the terms and conditions in Attachment A.

[Signatures follow]

**City of Beatrice, Nebraska**

By: \_\_\_\_\_  
Name: \_\_\_\_\_  
Title: \_\_\_\_\_  
Date: \_\_\_\_\_

**City of Superior, Nebraska**

By: \_\_\_\_\_  
Name: \_\_\_\_\_  
Title: \_\_\_\_\_  
Date: \_\_\_\_\_

ATTACHMENT A

DELIVERABLE CAPACITY TRANSACTION  
CONFIRMATION AGREEMENT  
DATED MAY 1, 2026

**OTHER TERMS AND CONDITIONS**

**CONTACT INFORMATION**

**Name:** City of Superior, Nebraska ("Party A")

**All Notices:**

Street: 134 West 4<sup>th</sup> Street

City: Superior, NE                      Zip: 68978

Attn: City Administrator

Phone: 402-879-4713

Facsimile: 402-879-4907

Federal Tax ID Number \_\_\_\_\_

**Name:** City of Beatrice, Nebraska ("Party B")

**All Notices:**

Street: 400 Ella Street

City: Beatrice, NE                      Zip: 68310

Attn: Board of Public Works

Phone: 402-228-5211

Facsimile: 402-228-4586

Federal Tax ID Number: \_\_\_\_\_

**Events of Default and Remedies:**

- Events of Default: An "Event of Default" means, with respect to a Party (a "Defaulting Party"), the occurrence of any of the following:
  - Failure to make, when due, any payment required pursuant hereto if such failure is not remedied within five (5) business days after written notice;
  - Failure to deliver or receive Product when due pursuant to this Agreement, unless caused by an event of "Force Majeure";
  - Any representation or warranty made by such Party herein is false or misleading in any material respect when made or when repeated;
  - Such Party becomes bankrupt; or
  - A Party's failure to perform any other material obligation set forth herein if such failure is not remedied within twenty (20) business days after written notice.
- Declaration of Early Termination Date and Calculation of Settlement Amounts: If an Event of Default with respect to a Defaulting Party occurs and continues for more than five (5) business days, the other Party (the "Non-Defaulting Party") will have the right to (a) upon two (2) business days' written notice to the Defaulting Party to terminate this Agreement ("Early Termination Date"), to accelerate all amounts owing between the Parties and to liquidate and terminate any transactions related to this Agreement, (b) withhold any

payments due to the Defaulting Party under this Agreement, and (c) suspend performance.

- **Limitation of Liability:** IN THE EVENT OF A DEFAULT, THE DEFAULTING PARTY'S LIABILITY SHALL BE LIMITED TO DIRECT, ACTUAL DAMAGES ONLY, AND SUCH DIRECT, ACTUAL DAMAGES SHALL BE THE SOLE AND EXCLUSIVE REMEDY HEREUNDER. IN NO EVENT WILL EITHER PARTY BE LIABLE TO THE OTHER FOR PUNITIVE, EXEMPLARY, OR INDIRECT DAMAGES, LOST PROFIT OR BUSINESS INTERRUPTION DAMAGES, BY STATUTE, IN TORT, CONTRACT OR OTHERWISE.

**Assignment of Contract:**

Neither Party shall have the right to assign this Agreement or rights hereunder, except by the express written consent of the other Party. Permission shall not be unreasonably withheld.

**Waiver of Default:**

No waiver of any term, provision or condition of this Agreement, the breach or default thereof, by conduct or otherwise, in one or more instances shall be deemed to be either a continuing waiver or waiver of a subsequent breach or default of any such term, provision or condition of this Agreement.

**Force Majeure:**

The term "Force Majeure," as used herein, shall mean any cause or causes not reasonably within the control and without the fault or negligence of the affected Party which wholly or partly prevents the performance of any of its obligations under this Agreement, including, without limitation by enumeration, acts of God, acts of the public enemy, acts of terrorism or threats thereof (or actions to prevent the same), blockades, strikes or differences with workmen, civil disturbances, fires, explosions, storms, floods, landslides, washouts, pandemics or epidemics, labor and material shortages, boycotts, breakdowns of or damage to equipment or facilities and actions to prevent the same, interruptions to supply or delays in transportation, embargoes, inability to obtain or renew a necessary license, permit or approval, acts of military authorities, acts of local, state or federal agencies or regulatory bodies, court actions, bankruptcy court actions, arrests and restraints.

If an event defined as Force Majeure occurs, and the affected Party is unable to carry out any of its obligations under this Agreement, then upon the affected Party giving written notice to the other Party of such Force Majeure, the affected Party's obligations shall be suspended from and after the date of the Force Majeure specified in the notice to the extent made necessary by such Force Majeure and during its continuance. The notice shall specify in detail (to the extent known) the nature of the Force Majeure, the obligations which the affected Party is unable to perform or furnish due to Force Majeure, and the affected Party's best estimate of the probable duration of the Force Majeure. The affected

Party shall use commercially reasonable efforts to eliminate and cure such Force Majeure insofar as possible and with a minimum of delay, and to resume full performance of its obligations.

**Choice of Law – Nebraska:**

This Agreement shall be governed by the laws of the State of Nebraska.

**Binding Contract:**

This Agreement shall be binding upon the Parties hereto, their successors, heirs, personal representatives, and assigns.

**Counterparts:**

This Agreement may be executed in any number of counterparts, each of which will be deemed an original, but all of which together will constitute one and the same instrument.

**Severability of Agreement:**

In the event that any of the terms of this Agreement shall be in conflict with and void as a result of the laws of the State of Nebraska, as the same may be from time to time amended, then the remainder of this Agreement shall remain in full force and effect.

**Enforceability:**

If any of the terms of this document are unenforceable, it shall in no way invalidate the balance of such Agreement.

**Entire Agreement:**

This instrument embodies the entire agreement of the Parties. There are no promises, terms, conditions, or obligations other than contained herein, and this agreement supersedes all previous communications, representations, or other agreements or contracts, either oral or written hereto.

**Miscellaneous:**

The headings of the paragraphs of this agreement are inserted for convenience only and shall not constitute a part hereof. Wherever applicable the singular shall include the plural and the masculine the feminine.

**Amendment:**

This Agreement may not be amended except by written consent of both Parties.



## AGENDA ITEM

**Subject:** Resolution executing the Utility Infrastructure & Ownership Maintenance Agreement with SCC, as recommended by the Board of Public Works

**For Agenda of:** June 15, 2026

**Exhibit(s):**

**Date Submitted:** June 10, 2026

### **Recommend a resolution executing the Utility Infrastructure & Ownership Maintenance Agreement with Southeast Community College Area, to the Mayor and City Council**

Tobias J. Tempelmeyer, City Administrator/General Manager, explained to the Board while reviewing utilities due to addition of the new Ag Building at Southeast Community College (SCC), it was found there was no delineation of ownership regarding utilities. This agreement lays out where ownership starts and stops, as well as defining who is responsible for the maintenance of the infrastructure.

Moved by Jones, seconded by Trauernicht, that the Mayor and City Council execute the Utility Infrastructure & Ownership Maintenance Agreement with Southeast Community College Area.

Roll Call: Yea: Baehr, Hartley, Jones, Trauernicht, Zarybnicky  
Nay: None

MOTION CARRIED.

**RESOLUTION NUMBER \_\_\_\_\_**

**WHEREAS**, since the mid-1970s Southeast Community College Area, a Nebraska community college and political subdivision (the “College”) has owned and operated a college campus in Beatrice, Nebraska; and

**WHEREAS**, since the College’s inception in Beatrice, Nebraska, the City has provided utility services to the College; and

**WHEREAS**, the College and the City of Beatrice, Nebraska desire to enter into a Utility Infrastructure & Ownership Maintenance Agreement to clearly delineate where the boundary of ownership and maintenance responsibilities of various utilities exist between the parties.

NOW, THEREFORE, BE IT RESOLVED BY THE MAYOR AND CITY COUNCIL OF THE CITY OF BEATRICE, NEBRASKA:

**SECTION 1.** That the Mayor and City Clerk of the City of Beatrice, Nebraska are hereby authorized to execute the Utility Infrastructure & Ownership Maintenance Agreement with Southeast Community College Area to clearly delineate where the boundary of ownership and maintenance responsibilities of various utilities exist between the parties. A copy of said Agreement, marked as Exhibit “A”, is attached hereto and incorporated herein by reference.

**SECTION 2.** That all resolutions or parts of resolutions in conflict herewith are hereby repealed.

RESOLUTION PASSED AND ADOPTED this 15<sup>th</sup> day of June, 2026.

Attest:

---

Erin Saathoff, MMC, City Clerk

---

Robert Morgan, Mayor

Exhibit "A"

## UTILITY INFRASTRUCTURE OWNERSHIP & MAINTENANCE AGREEMENT

This Agreement, dated the \_\_\_ day of June, 2026, is entered into by and between Southeast Community College Area, a Nebraska community college and political subdivision (the "College"), and the City of Beatrice, Nebraska, a municipal corporation ("City").

**WHEREAS**, since the mid-1970s the College has owned and operated a college campus in Beatrice, Nebraska; and

**WHEREAS**, since the College's inception in Beatrice, Nebraska, the City has provided utility services to the College; and

**WHEREAS**, the College and the City desire to clearly delineate where the boundary of ownership and maintenance responsibility of various utilities exist between the parties; and

**NOW, THEREFORE**, it is mutually understood and agreed as follows:

**1. Water Infrastructure.** The City serves the College with water via an eight (8) inch water main at the intersection of Highway 136 and Scott Street, and a twelve (12) inch water main along east side of Highway 136. The parties agree that the water infrastructure upstream of Service Valve #S116 shall be designated as the City's water infrastructure. There is an eight (8) inch cast iron pipe water line running southwest from Service Valve #S116 and connecting to the College Property which shall be designated as the College's water infrastructure. In addition to the eight (8) inch cast iron pipe, the vault located on the College's property shall be designated the College's water infrastructure.

The City also serves the College with water via a twelve (12) inch water main along east side of Highway 136 and along the south side of Progress Boulevard. There is a fire hydrant on this twelve (12) inch water main in the right-of-way on the west side of Highway 136. This fire hydrant and everything upstream shall be designated as the City's water infrastructure. The twelve (12) inch water main running along the south side of Progress Boulevard west or downstream of said fire hydrant shall be designated as the College's water infrastructure.

The College agrees that it shall install a valve on the twelve (12) inch water main running on the south side of Progress Boulevard, west of the fire hydrant were ownership transfers. The College shall install said value prior to a certificate of occupancy being issued for the Ag Technology Center currently under construction.

The College agrees that it shall install a water meter and back flow device anytime it taps into the twelve (12) inch water main running on the south side of Progress Boulevard and any extensions thereto.

All other service lines, valves, fire hydrants, and other water infrastructure remaining on the College Property, and in the Highway 136 right-of-way connecting to the City's water infrastructure and not owned by the City shall be designated as the College's water infrastructure. The College shall be responsible for maintenance of the College's water infrastructure. The City shall be responsible for maintenance of the City's water infrastructure. A map of the City's water infrastructure is attached as Exhibit "A".

**2. Sanitary Sewer Infrastructure.** The City serves the College with sanitary sewer infrastructure via a sanitary sewer line ranging in size between eight (8) to twelve (12) inches along the east side of the College Property. The parties agree that the sanitary sewer line consisting of manhole B59-2, B59, B58, B57, B56, B55, B54, B54-1, B54-3, B54-5, and B54-7 shall be designated as the City's sanitary sewer main. The College's sanitary sewer lines include the sanitary sewer line extending west along Progress Boulevard from manhole B54-7 which includes manhole B54-9, the sanitary sewer line extending west from manhole B55 which includes manholes B55-1, B55-3, and B55-5, and the sanitary sewer line extending west from manhole B59 which includes manhole B60. Any sanitary sewer lines on the College Property that are not the City's sanitary sewer main shall be owned and maintained by the College. The City shall be responsible for maintenance of the City's sanitary sewer main. A map of the City's sanitary sewer line is attached as Exhibit "B".

**3. Electric Infrastructure.** The City serves the College with electric infrastructure via primary electrical infrastructure, which includes high-voltage cables and transformers. The parties agree that all the primary electrical infrastructure shall be designated as the City's electric infrastructure. The City shall be responsible for maintenance on the City's primary electrical infrastructure. The College shall be responsible for the secondary electrical infrastructure located on the College Property, which is limited to the low-voltage cables going into its buildings from a transformer. The parties agree that all street lights located on the College Property shall be designated as belonging to the College. The College shall be responsible for maintenance of the street lights located on the College Property. A map of the City's electrical infrastructure is attached as Exhibit "C".

**4. Stormwater Infrastructure.** The College has stormwater detention infrastructure located throughout the College Property. The parties agree that all stormwater detention infrastructure located on the College Property shall be designated as the College's stormwater detention infrastructure. The drainage ditch located in the City's right-of-way that runs parallel to and along Highway 136 and all associated stormwater detention infrastructure located within said right-of-way shall be designated as the City's stormwater detention infrastructure. The College shall be responsible for maintenance of the College's stormwater detention infrastructure. The City shall be responsible for maintenance of the City's stormwater detention infrastructure.

**5. Street Infrastructure.** The City's ownership and maintenance responsibilities regarding street infrastructure stops at the west right-of-way line of Highway 136. Except as provided below, the College shall own and be responsible for the maintenance of all street infrastructure located within their property lines, including but not limited to drives, roads, streets, parking lots, and other paved or other hard surfaces. The City is in the process of vacating and conveying all of Progress Boulevard to the College. Upon said conveyance, the College shall own and be responsible for the maintenance of the road currently known as Progress Boulevard. The parties acknowledge and agree that since the College Property adjacent to and south of West Scott Road is not platted, the College owns all property up to the center line of West Scott Road. The parties agree that the City shall be responsible for the maintenance of West Scott Road for the length of West Scott Road lying north of and adjacent to the College Property beginning at the centerline

of West Scott Road and running south to the typical edge of right-of-way, which is 40 ft. The parties further agree that in the event the College replats the College Property lying south of and adjacent to West Scott Road, the College will designate where the City's right-of-way lies.

**6. Maintenance Responsibility.** The College further acknowledges that it bears sole responsibility for the routine maintenance, repair, inspection, rehabilitation, and replacement of College-owned utility infrastructures identified in Sections 1 through 5 above. The College shall maintain such infrastructure in a safe, functional, and code-compliant condition in accordance with applicable federal, state, and local regulations. The City acknowledges that it bears sole responsibility for the routine maintenance, repair, inspection, rehabilitation, and replacement of City-owned utility infrastructures identified in Sections 1 through 5 above. The City shall maintain such infrastructure in a safe, functional, and code-compliant condition in accordance with applicable federal, state, and local regulations.

**7. Easements to City.** The College hereby grants City a blanket easement across all of the College Property for the installation and maintenance of City's electrical infrastructure. The parties shall work together to determine the precise location of City's electrical infrastructure. The College shall grant City an easement for the City sanitary sewer line identified in Section 2 for the installation and maintenance of said sanitary sewer line. The parties shall work together to determine the precise location of said sanitary sewer line and draft an appropriate easement. The parties agree that the City shall be responsible for drafting said sanitary sewer line easement.

**8. Exclusion of City Easement Areas.** Nothing in this Agreement shall be construed to assign to the College any ownership or maintenance responsibility for utility infrastructure located within the City's easements. The City retains all rights, responsibilities, and authority with respect to infrastructure within its easement boundaries.

**9. Costs and Expenses.** Each party hereto shall be solely responsible for all costs associated with the maintenance, repair, or replacement of its own respective utility infrastructure, as described in this Agreement. Notwithstanding the foregoing, if damage to one party's utility infrastructure is caused by the negligence or willful misconduct of the other party, its agents, employees, or contractors, the negligent or willful party shall be responsible for the costs of repairing or replacing the damaged infrastructure.

**10. Updates and Amendments.** This Agreement shall remain in effect unless and until formally amended in writing by both parties. Should campus utility infrastructure boundaries change due to construction, renovation, or other activities, the College shall coordinate with the City of Beatrice accordingly and retain documentation of such changes in its facilities records.

**11. Disputes Settled by Mutual Agreement.** Both parties agree that in the event of a dispute of ownership and/or responsibility regarding utility infrastructure boundaries, such dispute shall be settled by the mutual written agreement of both parties.

**12. Indemnification.** Each party hereby agrees to indemnify, defend, and hold harmless the other party, its officers, employees, agents, contractors, subcontractors, and representatives from and against any and all claims, demands, liabilities, damages, losses, costs, and expenses, including reasonable attorneys' fees, arising out of or resulting from the negligent or willful acts or omissions of the other party, its officers, employees, agents, or contractors, subcontractors, and representatives in connection with the performance of this Agreement or the ownership, maintenance, or operation of its respective utility infrastructure described herein. This indemnification obligation shall survive the termination or expiration of this Agreement.

**13. Notices.** Notices to City shall be given to Taylor Rivera, 400 Ella Street, Beatrice, NE, 68310.

Notice to Buyer shall be sent to College, c/o Paul Illich, 301 South 68<sup>th</sup> Street, Lincoln, NE 68510.

**14. Assignability.** The rights and obligations set forth in this Agreement may not be assigned by either party without the prior written consent of the other party.

**15. Counterparts.** This Agreement may be executed in any number of counterparts, each of which shall be deemed an original, but all of which together will constitute one and the same instrument.

IN WITNESS WHEREOF, the parties hereto have set their hands and seals the day and year first above written, on this Memorandum of Understanding.

Paul Illich, on behalf of Southeast  
Community College Area, a Nebraska  
Community college and political  
subdivision

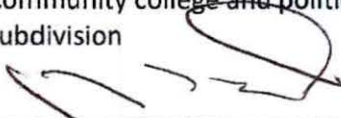

---

Paul Illich, President

Attest:

CITY OF BEATRICE, NEBRASKA  
A Nebraska Municipal Corporation

---

Erin Saathoff, City Clerk

---

Robert Morgan, Mayor

STATE OF NEBRASKA            )  
  ) ss.  
COUNTY OF   Lancaster    )

The foregoing instrument was acknowledged before me this   3<sup>rd</sup>   day of   June  , 2026, by Paul Illich, President and authorized signatory Southeast Community College Area, as his voluntary act and deed on behalf of Southeast Community College Area.

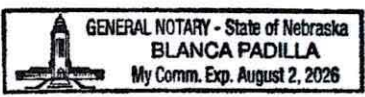

  Blanca Padilla    
Notary Public

STATE OF NEBRASKA            )  
  ) ss:  
COUNTY OF GAGE            )

The foregoing instrument was acknowledged before me this \_\_\_\_\_ day of \_\_\_\_\_, 2026, by Robert Morgan, Mayor, and authorized signatory of the City of Beatrice, Nebraska, to be his voluntary act and deed on behalf of the City of Beatrice, Nebraska.

\_\_\_\_\_  
Notary Public

5-099

Reed St  
Hwy 136

8" PVC  
To 1400 W Scott Rd

12" CIP Inside  
20" Steel Casing

10" CIP

W. Scott

8" CIP

12" CIP

8" Gate Valve # S116  
In Vault 28 turns  
8" 45 Bend

8" CIP  
To SCC- Main Campus

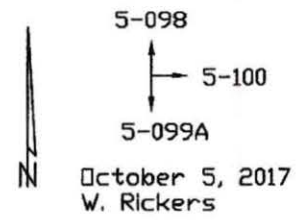

5-099

Exhibit 4A

# West Hydrant

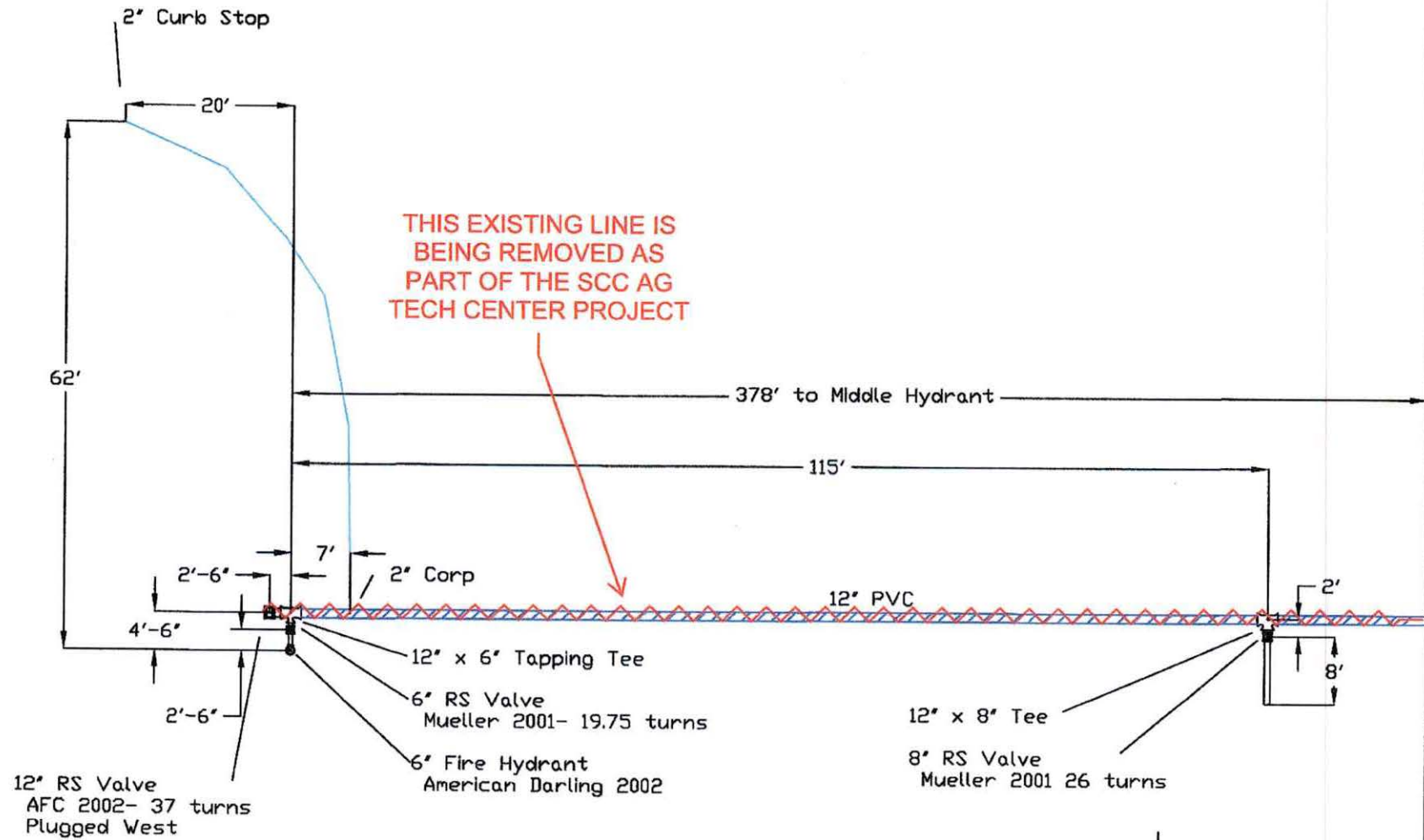

October 10, 2017  
W. Rickers

Middle Fire Hydrant

Progress Blvd

SCC WILL OWN THE 12" WATER MAIN

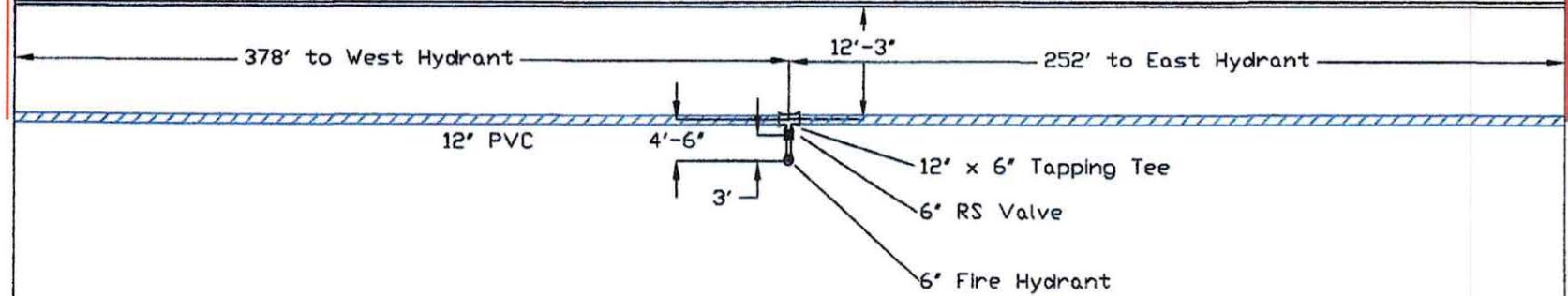

October 10, 2017  
W. Rickers

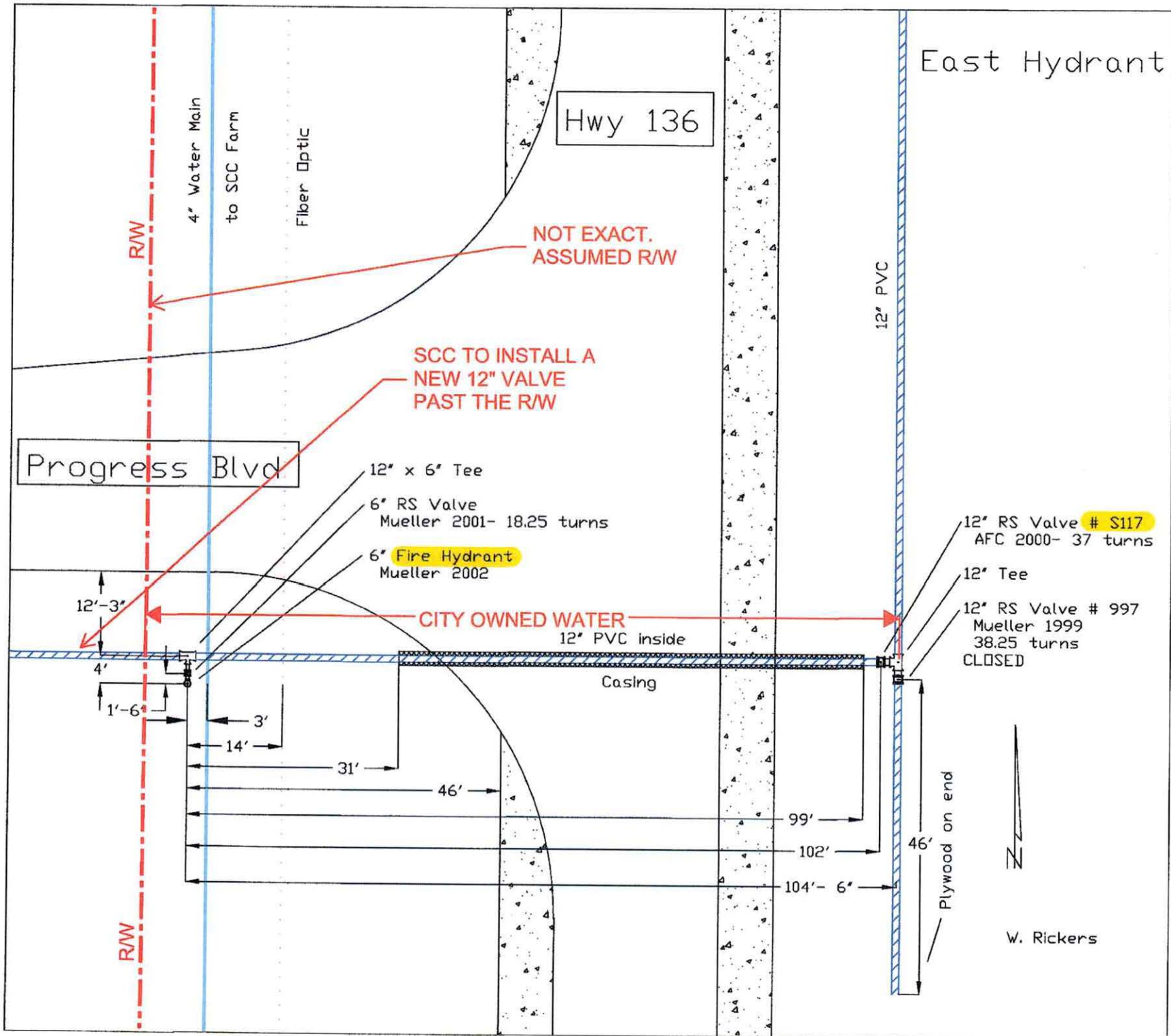

East Hydrant

Hwy 136

Progress Blvd

R/W

4" Water Main  
to SCC Farm  
Fiber Optic

NOT EXACT.  
ASSUMED R/W

SCC TO INSTALL A  
NEW 12" VALVE  
PAST THE R/W

- 12" x 6" Tee
- 6" RS Valve  
Mueller 2001- 18.25 turns
- 6" Fire Hydrant  
Mueller 2002

12" RS Valve # S117  
AFC 2000- 37 turns

12" Tee

12" RS Valve # 997  
Mueller 1999  
38.25 turns  
CLOSED

CITY OWNED WATER  
12" PVC inside

Casing

12'-3"

4'

1'-6"

3'

14'

31'

46'

99'

102'

104'- 6"

12" PVC

Plywood on end



W. Rickers



# Exhibit B<sup>h</sup>

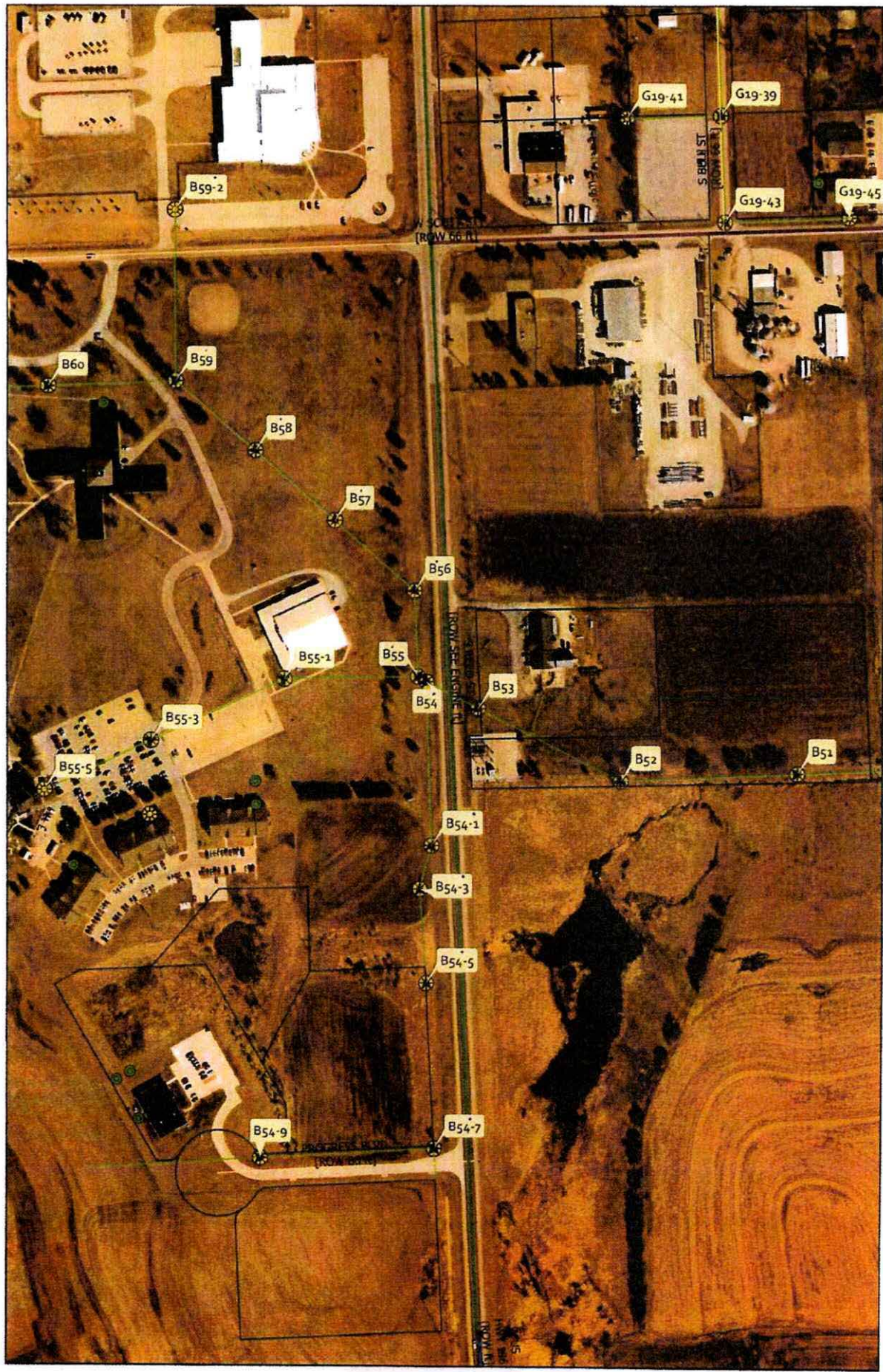

Exhibit "C"



**RESOLUTION NUMBER \_\_\_\_\_**

**WHEREAS**, the Mayor and City Council are authorized by ordinance to regulate parking;  
and

**WHEREAS**, the Mayor and City Council have determined that it would be in the best interest of the City of Beatrice, Nebraska that parking be prohibited along the east side of 7<sup>th</sup> Street from Perkins Street to Scott Street; along the west side of 8<sup>th</sup> Street from Perkins Street to Scott Street; and along the north side of Perkins Street from 7<sup>th</sup> Street to 8<sup>th</sup> Street, as shown in Exhibit "A", attached hereto and incorporated herein by reference.

NOW, THEREFORE, BE IT RESOLVED BY THE MAYOR AND CITY COUNCIL OF THE CITY OF BEATRICE, NEBRASKA:

**SECTION 1.** That effective immediately, parking be and hereafter is prohibited along the east side of 7<sup>th</sup> Street from Perkins Street to Scott Street; along the west side of 8<sup>th</sup> Street from Perkins Street to Scott Street; and along the north side of Perkins Street from 7<sup>th</sup> Street to 8<sup>th</sup> Street, as shown in Exhibit "A".

**SECTION 2.** That the City of Beatrice, Nebraska, and Board of Public Works is hereby authorized and directed to erect the necessary signs and change parking markings so as to prohibit parking along the east side of 7<sup>th</sup> Street from Perkins Street to Scott Street; along the west side of 8<sup>th</sup> Street from Perkins Street to Scott Street; and along the north side of Perkins Street from 7<sup>th</sup> Street to 8<sup>th</sup> Street, as required by this resolution.

**SECTION 3.** That all resolutions or parts of resolutions in conflict hereby are hereby repealed.

RESOLUTION PASSED AND ADOPTED this 15<sup>th</sup> day of June, 2026.

Attest:

---

Erin Saathoff, MMC, City Clerk

---

Robert Morgan, Mayor

# EXHIBIT "A"

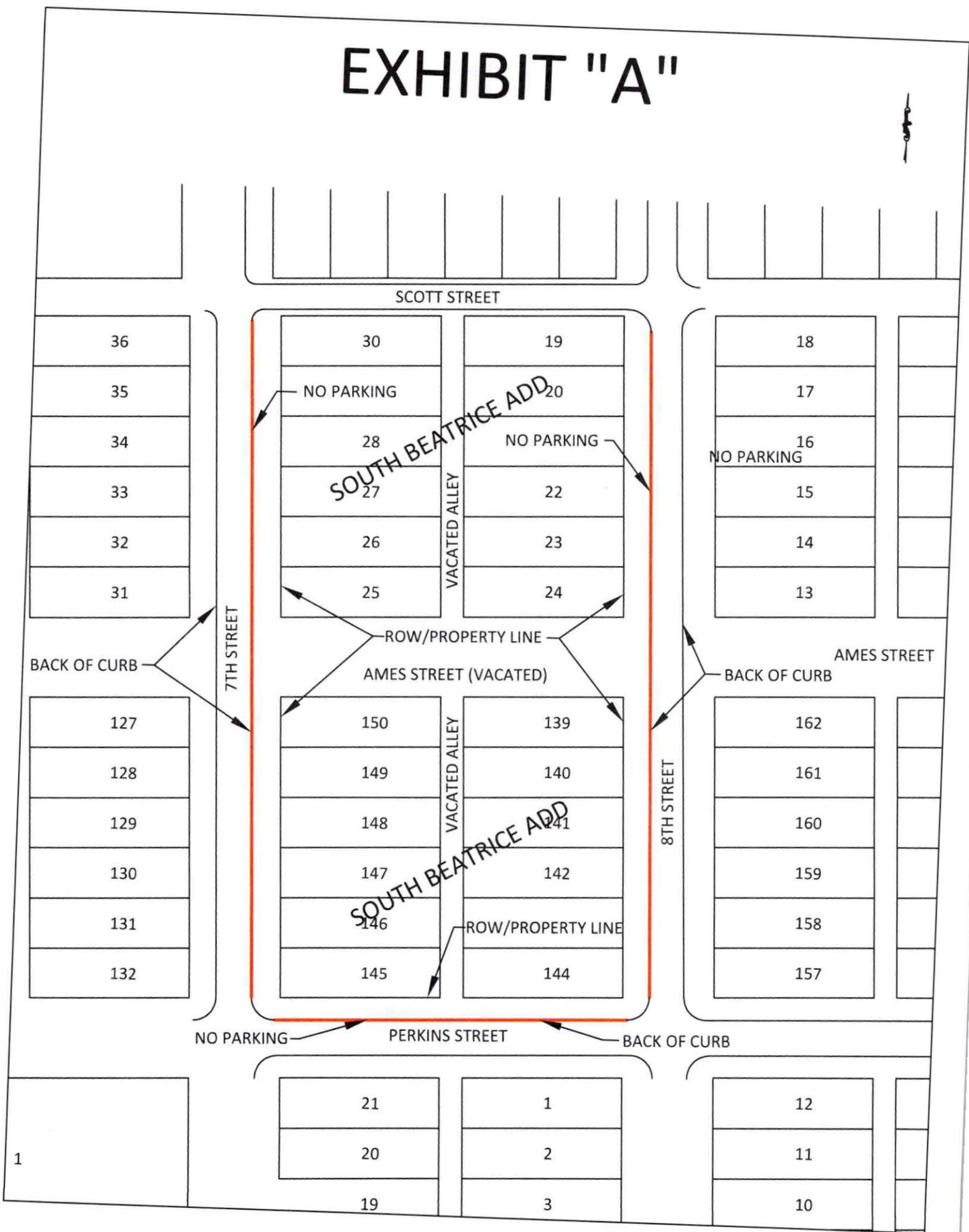

**RESOLUTION NUMBER \_\_\_\_**

**WHEREAS**, the City of Beatrice is developing a transportation project for which it intends to obtain Federal funds; and

**WHEREAS**, the City of Beatrice as a sub-recipient of Federal-Aid funding is charged with the responsibility of expending said funds in accordance with Federal, State, and local laws, rules, regulations, policies, and guidelines applicable to the funding of the Federal-aid project; and

**WHEREAS**, the City of Beatrice and JEO Consulting Group, Inc., wish to enter into a Professional Services Agreement to provide Environmental Services for the Federal-aid project.

NOW, THEREFORE, BE IT RESOLVED BY THE MAYOR AND CITY COUNCIL OF THE CITY OF BEATRICE, NEBRASKA:

**SECTION 1.** That the Mayor is hereby authorized to execute the Environmental Services Agreement between the City of Beatrice and JEO Consulting Group, Inc., for:

NDOT Project Number: DPS-34(46)

NDOT Control Number: 13608

NDOT Project Description: Beatrice Court Street Access and Safety Transformation  
("CAST") Initiative

A copy of said Agreement, marked as Exhibit "A", is attached hereto and incorporated by reference.

**SECTION 2.** That all resolutions or parts of resolutions in conflict herewith are hereby repealed.

RESOLUTION PASSED AND ADOPTED this 15<sup>th</sup> day of June, 2026.

Attest:

\_\_\_\_\_  
Erin Saathoff, MMC, City Clerk

\_\_\_\_\_  
Robert Morgan, Mayor

Exhibit "A"

Agreement No.	BK2609
NTP Date	2/23/2026
Agreement Amount	CPFF \$45,749.52

## PROFESSIONAL SERVICES AGREEMENT

### LPA PROJECTS ENVIRONMENTAL SERVICES

CITY OF BEATRICE  
JEO CONSULTING GROUP, INC.  
PROJECT NO. DPS-34(46)  
CONTROL NO. 13608  
BEATRICE COURT STREET ACCESS & SAFETY  
TRANSFORMATION (CAST) INITIATIVE

**THIS AGREEMENT** is between the City of Beatrice ("LPA") and JEO Consulting Group, Inc. ("Consultant"), collectively referred to as the "Parties".

#### WITNESSETH

**WHEREAS**, "State" means the Nebraska Department of Transportation in Lincoln, Nebraska, its Director, or authorized representative. The State will act as an agent of LPA and will represent the interests of the United States Department of Transportation in the development and construction of such LPA's project when State is managing the project on behalf of the LPA, and

**WHEREAS**, "LPA" for this Agreement means City of Beatrice who has jurisdictional responsibility over the transportation facility that will be the subject of this Agreement with Consultant. In this Agreement, LPA may also be used to refer to all Local Public Agencies, collectively. Local Public Agencies include, but are not necessarily limited to; Nebraska Cities, Villages, Counties, Political Subdivisions, Native American Tribes, and other entities or organizations found to be eligible sub recipients of federal funds for transportation projects, and

**WHEREAS**, State is authorized by state law to assist Nebraska Local Public Agencies, hereinafter referred to as LPA or LPAs, with obtaining and expending federal funds for local transportation projects, and

**WHEREAS**, State is presently assisting LPAs in the development of Federal-aid LPA transportation projects for local streets, roads and facilities, and

**WHEREAS**, LPA desires that this project be developed and constructed under the designation of Project No. DPS-34(46) and formally authorizes the signing of this Agreement by the Mayor, as evidenced by the Resolution of LPA dated \_\_\_\_\_ day of \_\_\_\_\_, 20\_\_\_\_, attached as Exhibit "F" and incorporated herein by this reference, and

**WHEREAS**, LPA used a qualification-based selection process to select Consultant to provide Environmental services, hereinafter referred to as "Services", and

**WHEREAS**, Consultant is qualified to do business in Nebraska and has met all requirements of the Nebraska Board of Engineers and Architects to provide consultant engineering services in the State of Nebraska, and

**WHEREAS**, LPA and Consultant wish to enter into this Agreement to specify the duties and obligations of the Parties for the Services described herein, and

**WHEREAS**, Consultant is willing to perform Services in accordance with the terms hereinafter provided, agrees to comply with all federal, state, and local laws and ordinances applicable to this Agreement, and agrees to comply with all applicable federal-aid transportation project

PROFESSIONAL SERVICES AGREEMENT

related program requirements, so that Consultant's costs under this Agreement will be eligible for federal reimbursement, and

**WHEREAS**, LPA and Consultant intend that these Services be completed in accordance with the terms and conditions of the Nebraska LPA Guidelines Manual for Federal-Aid Projects; hereinafter referred to as "LPA Manual". The LPA Manual is a document approved by the Federal Highway Administration (FHWA) that sets out the requirements for local federal-aid projects to be eligible for federal reimbursement; the LPA Manual can be found in its entirety at the following web address: <http://dot.nebraska.gov/media/6319/lpa-guidelines.pdf>, and

**WHEREAS**, Consultant should request from LPA or State the contact information for Consultant's primary point of contact for this project, and

**WHEREAS**, the Parties understand that this Agreement will be posted to a publicly accessible database of State agreements pursuant to the requirements Neb. Rev. Stat. § 84-602.04.

**NOW THEREFORE**, in consideration of these facts and mutual promises, the Parties hereto agree as follows:

**SECTION 1. CONTACT INFORMATION**

Contact information, for the convenience of the Parties, is as follows:

1.1 Consultant Project Manager

Firm Name	JEO Consulting Group, Inc.
Contractor/Vendor	6084
Address	1937 N Chestnut St., Wahoo, NE
Project Manager's	Jon Olsen
Project Manager's	402-525-4586

1.2 State Project Coordinator

Name	Jenna Habegger
Phone Number	402-479-3607

1.3 LPA RC

Name	Tobias Tempelmeyer
Phone Number	402-228-5200

1.4 State Agreements Specialist

Name	Lucinda Dowding
Phone Number	402-479-3127

**SECTION 2.** *This section has intentionally been left blank.*

**SECTION 3.** *This section has intentionally been left blank.*

**SECTION 4. NOTICE TO PROCEED AND COMPLETION SCHEDULE**

- 4.1 State, on behalf of LPA, issued Consultant a written Notice to Proceed on February 23, 2026. Invoiced charges for services performed by Consultant on the project prior to the date specified in the written Notice to Proceed will not be eligible for reimbursement.
- 4.2 In the event that prior to the Effective Date of this Agreement, Consultant is issued a Notice to Proceed and Consultant began work, Consultant will be paid for such work in accordance with this Agreement and the Parties are bound by this Agreement as if the work had been completed after the Effective Date of the Agreement.
- 4.3 Consultant shall complete the Services according to the schedule in attached Exhibit "A" and shall complete all Services required under this Agreement in a satisfactory manner by August 31, 2028. Costs incurred by Consultant after the completion date, are not

## PROFESSIONAL SERVICES AGREEMENT

eligible for reimbursement unless Consultant has received a written extension of time from LPA or State, on LPA's behalf. Extensions of the time to complete the Services must not be construed as an extension to the duration of the agreement.

- 4.4 The completion date will not be extended because of any avoidable delay attributed to Consultant, but delays not attributable to Consultant, such as delays attributable to LPA or State, may, upon request, constitute a basis for an extension of time.

### **SECTION 5. DURATION OF THE AGREEMENT (Matches Project Lifespan)**

- 5.1 Effective Date – This Agreement is effective when executed by the Parties.
- 5.2 Expiration Date -- This Agreement expires when State has (a) completed the project final audit and cost settlement or (b) waived the requirement of a financial audit.
- 5.3 Duration of the Agreement – The Agreement duration is from the Effective Date to the Expiration Date. The Agreement duration is "specified" under Neb. Rev. Stat. § 73-506 to the period of time necessary for a Consultant to complete the applicable phase or phases of the development of this particular federal, state or locally funded construction project, including when applicable, the time during construction of the project.
- 5.4 Identifying Date – This Agreement may be identified by the date LPA signed the agreement.
- 5.5 Termination or Suspension – LPA, or State on LPA's behalf, reserves the right to terminate or suspend this Agreement at any time for any of the reasons provided herein.

### **SECTION 6. SCOPE OF SERVICES**

- 6.1 LPA and Consultant understand that the Services provided by Consultant must be completed in accordance with all federal-aid reimbursement requirements and conditions. Consultant shall provide Environmental services for project DPS-34(46), Beatrice, in Gage County, Nebraska. The Scope of Services ("Services") is outlined in Exhibit "A", attached and incorporated herein by this reference.
- 6.2 Exhibit "A" is the result of the following process:
- 6.2.1 Consultant was provided with a document describing the detailed proposed Scope of Services for this project
- 6.2.2 Consultant made necessary and appropriate proposed additions, deletions, and revisions to the detailed Scope of Services document
- 6.2.3 Consultant participated in a review of the proposed Scope of Services, and the proposed revisions, and negotiated the final detailed Scope of Services and Fee Proposal document, as shown in Exhibit "A" and Exhibit "B", attached and incorporated herein by this reference.
- 6.3 LPA, or State on LPA's behalf, reserves the unconditional right to add to, subtract from, or alter the Scope of Services at any time and such action on its part will in no event be deemed a breach of this Agreement. The addition, subtraction, or alteration will become effective seven (7) days after mailing written notice of such addition, subtraction, or alteration.
- 6.4 Any change in the Services will follow the process specified in the *Out-of-Scope Services* section in Exhibit "C", attached and incorporated herein by this reference.

**SECTION 7. STAFFING PLAN (PE)**

- 7.1 Consultant has provided LPA and State with a Staffing Plan or Staffing Plans, described in Exhibit "B". The Staffing Plan identifies the employees of Consultant, and when applicable subconsultants, who are anticipated to provide Services under this Agreement. Consultant understands that LPA and State are relying on key personnel from the Staffing Plan to be primarily responsible for completing the Services under this Agreement. LPA and State consider the Principals, senior level staff, Project Managers, Team Leaders or other similar classifications, to be the key personnel for the Services provided. Consultant and, when applicable subconsultants, may make occasional temporary changes to the key personnel. However, any permanent change to Consultant's or subconsultant's key personnel will require prior written approval from LPA, or State on LPA's behalf.
- 7.2 Personnel who are added to the Staffing Plan as replacements must be persons of comparable training and experience. Personnel added to the Staffing Plan as new personnel and not replacements must be qualified to perform the intended services. Failure on the part of Consultant or subconsultant to provide acceptable replacement personnel or qualified new personnel to keep the Services on schedule will be cause for termination of this Agreement, with settlement to be made as set out on Exhibit "C".

**SECTION 8.** *This section has intentionally been left blank.*

**SECTION 9. NEW EMPLOYEE WORK ELIGIBILITY STATUS**

- 9.1 Consultant agrees to use a federal immigration verification system to determine the work eligibility status of new employees physically performing services within the State of Nebraska. Consultant agrees to contractually require any subconsultants to use a federal immigration verification system to determine the work eligibility status of new employees physically performing services within the State of Nebraska. A federal immigration verification system means the electronic verification of the work authorization program authorized by the Illegal Immigration Reform and Immigrant Responsibility Act of 1996, 8 U.S.C. 1324a, known as the E-Verify Program, or an equivalent federal program designated by the United States Department of Homeland Security or other federal agency authorized to verify the work eligibility status of a newly hired employee.
- 9.2 The undersigned duly authorized representative of Consultant, by signing this Agreement, hereby attests to the truth of the following certifications, and agrees as follows:
- Neb. Rev. Stat. § 4-114. I certify compliance with the provisions of Section 4-114 and, hereby certify that this Consultant shall register with and use a federal immigration verification system to determine the work eligibility status of new employees physically performing services within the State of Nebraska. I agree to require all subconsultants, by contractual agreement, to require the same registration and verification process.
- 9.3 If Consultant is an individual or sole proprietorship, the following applies:
- a. Consultant must complete the United States Citizenship Attestation form and attach it to this Agreement. This form is available on the Department of Transportation's website at <http://dot.nebraska.gov/media/2802/ndot289.pdf>.

## PROFESSIONAL SERVICES AGREEMENT

- b. If Consultant indicates on such Attestation form that he or she is a qualified alien, Consultant agrees to provide the US Citizenship and Immigration Services documentation required to verify Consultant lawful presence in the United States using the Systematic Alien Verification for Entitlements (SAVE) Program.
- c. Consultant understands and agrees that lawful presence in the United States is required and Consultant may be disqualified or the contract terminated if such lawful presence cannot be verified as required by Neb. Rev. Stat. §4-108.

### **SECTION 10. FEES AND PAYMENTS**

- 10.1 Consultant's fee proposal is attached as Exhibit "B" and incorporated herein by this reference.
- 10.2 The maximum compensation amounts and general provisions concerning payment under this Agreement are attached as Exhibit "C".

### **SECTION 11. CONSULTANT'S PERFORMANCE (LPA PE)**

#### 11.1 Standard of Performance

Consultant shall complete the Services under this Agreement exercising the degree of skill, care, and diligence consistent with the applicable professional standards recognized by such profession and observed by national firms performing services of the type provided for in this Agreement. Consultant shall complete the Services exercising good and sound professional judgment and practices. Consultant's Services shall conform to applicable licensing requirements, industry standards, statutes, laws, acts, ordinances, and rules and regulations.

#### 11.2 Quality of Service

Consultant agrees to perform all Services hereunder using qualified personnel consistent with good professional practice in the state of the art involved, and that performance of its personnel will reflect their best professional knowledge, skill, and judgment. Consultant agrees to permit LPA, or State on LPA's behalf, access at all times to the work product for purposes of reviewing same and determining that the Services are being performed in accordance with the terms of this Agreement.

#### 11.3 Performance Evaluation

11.3.1 LPA, or State on LPA's behalf, retains the discretion to conduct an evaluation of Consultant's performance at any time. Consultant's performance may be subject to an evaluation in the following performance categories: (1) Communication, Cooperation, and Project Management; (2) Schedule; (3) Scope and Budget; and (4) Quality and Technical Performance. Consultant understands that if LPA, or State on LPA's behalf, determines that Consultant's performance is not meeting, has not met, or is at risk of not meeting the Standard of Performance set out herein, LPA, or State on LPA's behalf, may conduct a Consultant Performance Evaluation based on the applicable foregoing performance categories. If LPA, or State on LPA's behalf, chooses to conduct a Consultant Performance Evaluation, LPA, or State on LPA's behalf, will notify Consultant of the evaluation including necessary instructions and procedures for complying with the evaluation.

11.3.2 Consultant shall, to the fullest extent reasonable, implement and make modifications and changes in response to the evaluation, correct deficiencies, implement improvements, and improve performance to comply with the terms of

## PROFESSIONAL SERVICES AGREEMENT

this Agreement in response to the Performance Evaluation. LPA's or State's remedies for substandard performance will apply even in the absence of a Consultant Performance Evaluation.

### 11.4 LPA's or State's Remedies for Substandard Performance

Upon notice of substandard performance of Services revealed during or after the construction of the project, Consultant shall re-perform the Services at no cost to LPA or State. Further, Consultant shall reimburse LPA or State for any costs incurred by LPA or State for necessary remedial work. Consultant shall respond to LPA's or State's notice of any errors, omissions, or negligence within twenty-four (24) hours and give immediate attention to necessary corrections to minimize any delays to the project. This may involve visits by Consultant to the project site, if directed by LPA or State. If Consultant discovers errors, omissions, or negligence in its Services, Consultant shall notify LPA and State of the errors within three (3) business days. Failure of Consultant to notify LPA and State constitutes a breach of this Agreement.

If Consultant fails to re-perform the Services, or if LPA or State determines that Consultant will be unable to correct substandard Services before the time specified for completion in this Agreement, LPA or State may correct such unsatisfactory Services (or by the use of third parties) and charge Consultant for the costs incurred.

If LPA or State requires Consultant to remedy any deficiencies in the Services, Consultant shall make such corrections at no additional cost to LPA or State. Any increase or decrease in the scope of the Services or any modification of the specifications will be made only by written agreement signed by the Parties. Consultant shall bear legal liability for all damages incurred by LPA or State caused by Consultant's errors, omissions, or negligent acts without liability or expense to LPA or State. The rights and remedies of LPA or State provided herein are in addition to any other remedies provided by law.

## **SECTION 12. CONSULTANT'S ACCOUNTABILITY FOR ITS SERVICES** (LPA)

- 12.1 Consultant agrees that LPA and State will rely on the professional training, experience, performance and ability of Consultant. Consultant agrees that examination by LPA, State, or Federal Highway Administration of the United States Department of Transportation (FHWA), approval, acceptance, use of, or acquiescence in Consultant's Services, will not be considered a full and comprehensive examination and will not be considered approval of Consultant's Services that would relieve Consultant from liability or expense connected with Consultant's sole responsibility for the propriety and integrity of Consultant's Services pursuant to this Agreement. Consultant agrees that LPA's or State's declining to approve Consultant's services will not be deemed an acceptance of defective services or relieve Consultant of its obligations and liabilities with respect to such services.
- 12.2 Consultant agrees that acceptance or approval of any of the services of Consultant by LPA or State or of payment, partial or final, will not constitute a waiver of any rights of LPA or State to recover from Consultant damages caused by Consultant due to error, omission, or negligence of Consultant in its services.

**SECTION 13. DISPUTES**

Any dispute concerning a question of fact in connection with the work will be addressed in accordance with LPA Manual Section 4.4.3.5 DISPUTE RESOLUTION.

**SECTION 14. SUSPENSION OR TERMINATION** (PE 2-25-16)

**14.1 Suspension or Termination**

LPA or State, on LPA's behalf, has the absolute right to suspend the work or terminate this Agreement at any time and for any reason and such action on its part will in no event be deemed a breach of this Agreement. Without limiting the rights set out in this section, the following is a non-exclusive list of the examples of the circumstances under which LPA or State may suspend or terminate this Agreement:

- a. A loss, elimination, decrease, or re-allocation of funds that make it difficult, unlikely or impossible to have sufficient funding for the Services or the project
- b. The Services or the project are abandoned for any reason
- c. Funding priorities have changed
- d. LPA's or State's interests are best protected by suspension or termination of this Agreement
- e. Consultant fails to meet the schedule, milestones, or deadlines established in this Agreement or agreed to in writing by the Parties
- f. Consultant fails to provide acceptable replacement personnel or qualified new personnel
- g. Consultant has not made sufficient progress to assure that the Services are completed in a timely manner
- h. Consultant fails to meet the standard of care applicable to the Services
- i. Consultant fails to meet the performance requirements of this Agreement
- j. Consultant's breach of a provision of this Agreement or failure to meet a condition of this Agreement
- k. Consultant's unlawful, dishonest, or fraudulent conduct in Consultant's professional capacity
- l. Consultant fails to complete the project design in a form that is ready for letting a contract for construction according to the approved contract documents, including, but not limited to, project plans and specifications

14.2 *This section has intentionally been left blank.*

**14.3 Suspension**

- a. Suspension for Convenience. If LPA or State, on LPA's behalf, suspends the work for convenience, Consultant will be given notice of the date of suspension, which date will be no fewer than three (3) business days after notice is given. Such notice will provide the reason(s) for such suspension. Consultant will not be compensated for any Services completed or costs incurred after the date of suspension. Consultant shall provide LPA and State a detailed summary of the current status of the Services completed and an invoice of all costs incurred up to and including the date of suspension.
- b. Suspension for Cause. If LPA or State, on LPA's behalf, suspends the work for cause or for issues related to performance, responsiveness or quality that must be corrected by Consultant, Consultant will be given notice of the date of suspension, which date will be no fewer than three (3) business days after notice is given. The

## PROFESSIONAL SERVICES AGREEMENT

notice of suspension will provide Consultant with the reason(s) for the suspension, a timeframe for Consultant to correct the deficiencies, and when applicable, and a description of the actions that must be taken for LPA or State to rescind the suspension. Consultant's right to incur any additional costs will be suspended at the end of the day of suspension and will continue until all remedial action is completed to the satisfaction of LPA and State. Failure to correct the deficiencies identified in a suspension will be grounds for termination of this Agreement.

### 14.4 Termination

If LPA or State, on LPA's behalf, terminates this Agreement, Consultant will be given notice of the date of termination, which will be no fewer than three (3) business days after notice is given. The notice of termination will provide Consultant with a description of the reason(s) for the termination. The notice must specify when the Agreement will be terminated along with the requirements for completion of the work under the Agreement. Consultant's right to incur any additional costs will cease at the end of the day of termination or as otherwise provided.

### 14.5 Compensation upon suspension or termination

If LPA or State, on LPA's behalf, suspends the work or terminates the Agreement, Consultant must be compensated in accordance with the provisions set out in Exhibit "C", provided however, that in the case of suspension or termination for cause or for Consultant's breach of this Agreement, LPA or State, on LPA's behalf, will have the power to suspend payments, pending Consultant's compliance with the provisions of this Agreement. In the event of termination of this Agreement for cause, LPA or State, on LPA's behalf, may make the compensation adjustments set out in Exhibit "C".

## **SECTION 15. OWNERSHIP OF DOCUMENTS**

- 15.1 All surveys, maps, studies, reports, computations, charts, plans, specifications, electronic data, shop drawings, diaries, field books, and other project documents prepared or obtained under the terms of this Agreement are the property of LPA. Consultant shall deliver these documents to LPA at the conclusion of the project for inclusion in LPA's federal-aid file without restriction or limitation as to further use.
- 15.2 LPA acknowledges that such data may not be appropriate for use on an extension of the Services covered by this Agreement or on other projects. Any use of the data for any purpose other than that for which it was intended without the opportunity for Consultant to review the data and modify it if necessary for the intended purpose will be at LPA's sole risk and without legal exposure or liability to Consultant.
- 15.3 Further, Consultant shall keep time sheets and payroll documents in Consultant's files for at least three years from the completion of final cost settlement by FHWA and project closeout by State.

## **SECTION 16. CONFLICT OF INTEREST LAWS**

Consultant shall review the Conflict of Interest provisions of 23 CFR 1.33 and 49 CFR 18.36(b)(3) and agrees to comply with all the Conflict of Interest provisions in order for LPA's project to remain fully eligible for federal funding. By signing this Agreement, Consultant certifies that Consultant is not aware of any financial or other interest Consultant has that would violate the terms of these federal provisions.

**SECTION 17. USE AND/OR RELEASE OF PRIVILEGED OR CONFIDENTIAL INFORMATION**

- 17.1 Certain information provided by LPA or State to Consultant is confidential information contained within privileged documents protected by 23 U.S.C. §407. "Confidential information" means any information that is protected from disclosure pursuant to state and federal law and includes, but is not limited to, accident summary information, certain accident reports, diagnostic evaluations, bridge inspection reports, and any other documentation or information that corresponds with said evaluations or reports, and any other information protected by 23 U.S.C. §407. "Privileged document" means any document pertaining to any file or project maintained by LPA or State that is privileged and protected from disclosure, pursuant to appropriate state and federal law, including any document containing attorney-client communications between an LPA or State employee and Legal Counsel. This confidential and privileged information is vital and essential to Consultant in order that Consultant adequately design the project at hand on behalf of LPA or State.
- 17.2 Consultant agrees it will only use any information or documentation that is considered to be privileged or confidential for the purposes of executing the services by which it has agreed to render for LPA or State for the project at hand only. Consultant agrees not to reveal, disseminate, or provide copies of any document that is confidential and privileged to any individual or entity. LPA or State agrees that any information or documentation that is considered to be privileged or confidential that is provided to Consultant will be marked with the following information (Approved 11/4/11):
- "CONFIDENTIAL INFORMATION: Federal Law, 23 U.S.C §407, prohibits the production of this document or its contents in discovery or its use in evidence in a State or Federal Court. The State of Nebraska [or LPA] has not waived any privilege it may assert as provided by that law through the dissemination of this document and has not authorized further distribution of this document or its contents to anyone other than the original recipient."*
- 17.3 Consultant agrees to obtain the written approval of LPA and State prior to the dissemination of any privileged or confidential information or documentation if it is unclear to Consultant whether such information or documentation is in fact privileged or confidential.
- 17.4 Consultant and LPA or State agree that any unauthorized dissemination of any privileged or confidential information or documentation on the part of Consultant will create liability on the part of Consultant to LPA or State for any damages that may occur as a result of the unauthorized dissemination. Consultant agrees to hold harmless, indemnify, and release LPA or State from any liability that may ensue on the part of LPA or State for any unauthorized dissemination of any privileged or confidential information or documentation on the part of Consultant.

**SECTION 18. FORBIDDING USE OF OUTSIDE AGENTS** (Standard provision)

Consultant warrants that it has not employed or retained any company or person, other than a bona fide employee working for Consultant, to solicit or secure this Agreement, and that it has not paid or agreed to pay any company or person, other than a bona fide employee, any fee, commission, percentage, brokerage fee, gift, or any other consideration contingent upon or resulting from the award or making of this Agreement. For breach or violation of this warranty, LPA or State has the right to annul this Agreement without liability or, in its discretion, to deduct

## PROFESSIONAL SERVICES AGREEMENT

from the agreement price or consideration, or otherwise recover the full amount of such fee, commission, percentage, brokerage fee, gift, or contingent fee.

### **SECTION 19. GENERAL COMPLIANCE WITH LAWS**

Consultant agrees to comply with all federal, state, and local laws and ordinances applicable to the work in effect at the time of the work. If Consultant is found to have been in violation of any applicable federal, state, or local laws and ordinances, such violation may be the basis for the suspension or termination under this Agreement.

### **SECTION 20. RESPONSIBILITY FOR CLAIMS AND LIABILITY INSURANCE (3-2-21)**

- 20.1 Consultant agrees to hold harmless LPA and State from all claims and liability due to the error, omission, or negligence of Consultant or those of Consultant's agents or employees in the performance of work under this Agreement. It is expected that in carrying out the work under this Agreement, Consultant will make various decisions and judgments and Consultant will determine what actions are required by Consultant and by others to properly complete the work. Nothing in this Agreement shall be interpreted to relieve Consultant from any liability it would otherwise have to LPA or State in carrying out the work under this Agreement.
- 20.2 For the duration of this Agreement, Consultant shall carry insurance as outlined in Exhibit "D", attached and incorporated herein by this reference. For any work to be performed by a subconsultant/subcontractor or other person/entity, at any tier, for Consultant, Consultant shall require that such subconsultant/subcontractor or other person/entity meet the insurance requirements outlined in Exhibit "D".

### **SECTION 21. COORDINATING PROFESSIONAL AND PROFESSIONAL REGISTRATION (2-1-18)**

#### **21.1 Coordinating Professional:**

To the extent of any design work applicable to the Services under this Agreement, the following Coordinating Professional language applies:

If LPA's project involves more than one licensed professional engineer, LPA shall designate a Coordinating Professional (defined in Neb. Rev. Stat. § 81-3408) for this project as required by Neb. Rev. Stat. § 81-3437.02 of the Nebraska Engineers and Architects Regulation Act (Neb. Rev. Stat § 81-3104 et seq.). The Coordinating Professional will apply his or her seal and signature and the date to the cover sheet of all documents and denote the seal as that of the Coordinating Professional. The Coordinating Professional will verify that all design disciplines involved in the project are working in coordination with one another, and that any changes made to the design are approved by the corresponding discipline. Consultant agrees to cooperate with the designated Coordinating Professional to meet the requirements of state law. Consultant further agrees to contractually require its subconsultants to cooperate with the designated Coordinating Professional.

If Consultant's engineer has been identified as the Coordinating Professional for this project, and, for whatever reason, the designated Coordinating Professional is no longer assigned to the project, Consultant shall provide LPA written notice of the name of the replacement within 10 business days.

## PROFESSIONAL SERVICES AGREEMENT

### 21.2 Professional Registration:

To the extent the work requires engineering services, Consultant will affix and sign the seal of a registered professional engineer or architect licensed to practice in the State of Nebraska, on all applicable documents, plans, specifications, and reports prepared under this Agreement as required by the Nebraska Engineers and Architects Regulations Act.

### **SECTION 22. SUCCESSORS AND ASSIGNS**

This Agreement is binding on successors and assigns of either party.

### **SECTION 23. DRUG-FREE WORKPLACE POLICY**

Consultant shall have, and comply with, an acceptable and current drug-free workplace policy on file with State. Consultant's employees shall not use illegal drugs or consume alcohol during work hours and while performing Services for State under this Agreement.

### **SECTION 24. FAIR EMPLOYMENT PRACTICES ACT**

Consultant agrees to abide by the Nebraska Fair Employment Practices Act, as provided by Neb. Rev. Stat. §§ 48-1101 through 48-1126.

### **SECTION 25. DISABILITIES ACT**

Consultant agrees to comply with the Americans with Disabilities Act of 1990 (P.L. 101-366), as implemented by 28 CFR 35.

### **SECTION 26. DISADVANTAGED BUSINESS ENTERPRISES**

- 26.1 Consultant shall ensure that disadvantaged business enterprises, as defined in 49 CFR 26, have the maximum opportunity to compete for and participate in the performance of subagreements financed in whole or in part with federal funds under this Agreement.
- 26.2 Consultant shall not discriminate on the basis of race, color, sex, age, disability, or national origin in the award and performance of FHWA-assisted contracts. Failure of Consultant to carry out the requirements set forth above will constitute a breach of this Agreement and, after the notification of the FHWA, may result in termination of this Agreement by LPA or State or such remedy as LPA or State deem appropriate.

### **SECTION 27. TITLE VI NONDISCRIMINATION CLAUSES** *(2023 NDOT Title VI Implementation Plan)*

- 27.1 Appendix A - During the performance of this contract, the Contractor, Consultant, or when applicable LPA, for itself, its assignees, and successors in interest (hereinafter referred to as the "contractor") agrees as follows:

#### 27.1.1 Compliance with Regulations

The contractor (hereinafter includes consultants) will comply with the Acts and the Regulations relative to nondiscrimination in federally-assisted programs of the U.S. Department of Transportation, the Federal Highway Administration, as they may be amended from time to time, which are herein incorporated by reference and made a part of this contract.

#### 27.1.2 Nondiscrimination

The contractor, with regard to the work performed by it during the contract, will not discriminate on the grounds of race, color, or national origin in the selection and retention of subcontractors, including procurements of materials and leases

PROFESSIONAL SERVICES AGREEMENT

of equipment. The contractor will not participate directly or indirectly in the discrimination prohibited by the Acts and Regulations, including employment practices when the contract covers any activity, project, or program set forth in Appendix B of 49 CFR 21.

27.1.3 Solicitations for Subcontracts, Including Procurements of Materials and Equipment

In all solicitations, either by competitive bidding, or negotiation made by the contractor for work to be performed under a subcontract, including procurements of materials, or leases of equipment, each potential subcontractor or supplier will be notified by the contractor of contractor's obligations under this contract and the Acts and the Regulations relative to Nondiscrimination on the grounds of race, color, or national origin.

27.1.4 Information and Reports

The Contractor will provide all information and reports required by the Acts, the Regulations, and directives issued pursuant thereto and will permit access to its books, records, accounts, other sources of information, and its facilities as may be determined by the Recipient or the Federal Highway Administration to be pertinent to ascertain compliance with such Acts, Regulations, and instructions. Where any information required of a contractor is in the exclusive possession of another who fails or refuses to furnish the information, the contractor will so certify to the Recipient or Federal Highway Administration, as appropriate, and will set forth what efforts it has made to obtain the information.

27.1.5 Sanctions for Noncompliance

In the event of contractor's noncompliance with the Nondiscrimination provisions of this contract, the Recipient will impose such contract sanctions as it or the Federal Highway Administration may determine to be appropriate, including, but not limited to:

27.1.5.1 withholding payments to the contractor under the contract until the contractor complies; and/or

27.1.5.2 cancelling, terminating, or suspending a contract, in whole or in part.

27.1.6 Incorporation of Provisions

The contractor will include the provisions of paragraphs 27.1.1 through 27.1.6 in every subcontract, including procurements of materials and leases of equipment, unless exempt by the Acts, the Regulations and directives issued pursuant thereto. The Contractor will take action with respect to any subcontract or procurement as the Recipient or the Federal Highway Administration may direct as a means of enforcing such provisions including sanctions for noncompliance. Provided, that if the contractor becomes involved in, or is threatened with litigation by a subcontractor, or supplier because of such direction, the contractor may request the Recipient to enter into any litigation to protect the interests of the Recipient. In addition, the contractor may request the United States to enter into the litigation to protect the interests of the United States.

27.2 Appendix E – During the performance of this contract, the Contractor, Consultant, or when applicable LPA, for itself, its assignees, and successors in interest (hereinafter referred to as the "contractor") agrees to comply with the following nondiscrimination statutes and authorities; including but not limited to:

## PROFESSIONAL SERVICES AGREEMENT

### Pertinent Nondiscrimination Authorities:

- 27.2.1 Title VI of the Civil Rights Act of 1964 (42 U.S.C. § 2000d et seq., 78 stat. 252), (prohibits discrimination on the basis of race, color, national origin); and 49 CFR Part 21.
- 27.2.2 The Uniform Relocation Assistance and Real Property Acquisition Policies Act of 1970, (42 U.S.C. § 4601), (prohibits unfair treatment of persons displaced or whose property has been acquired because of Federal or Federal-aid programs and projects);
- 27.2.3 Federal-Aid Highway Act of 1973, (23 U.S.C. § 324 et seq.), (prohibits discrimination on the basis of sex);
- 27.2.4 Section 504 of the Rehabilitation Act of 1973, (29 U.S.C. § 794 et seq.), as amended, (prohibits discrimination on the basis of disability); and 49 CFR Part 27;
- 27.2.5 The Age Discrimination Act of 1975, as amended, (42 U.S.C. § 6101 et seq.), (prohibits discrimination on the basis of age);
- 27.2.6 Airport and Airway Improvement Act of 1982, (49 U.S.C. § 4 71, Section 4 7123), as amended, (prohibits discrimination based on race, creed, color, national origin, or sex);
- 27.2.7 The Civil Rights Restoration Act of 1987, (PL 100-209), (Broadened the scope, coverage and applicability of Title VI of the Civil Rights Act of 1964, The Age Discrimination Act of 1975 and Section 504 of the Rehabilitation Act of 1973, by expanding the definition of the terms "programs or activities" to include all of the programs or activities of the Federal-aid recipients, subrecipients and contractors, whether such programs or activities are Federally funded or not);
- 27.2.8 Titles II and III of the Americans with Disabilities Act, which prohibit discrimination on the basis of disability in the operation of public entities, public and private transportation systems, places of public accommodation, and certain testing entities (42 U.S.C. §§ 12131-12189) as implemented by Department of Transportation regulations at 49 C.F.R. parts 37 and 38;
- 27.2.9 The Federal Aviation Administration's Nondiscrimination statute (49 U.S.C. § 47123) (prohibits discrimination on the basis of race, color, national origin, and sex);
- 27.2.10 Executive Order 12898, Federal Actions to Address Environmental Justice in Minority Populations and Low-Income Populations, which ensures discrimination against minority populations by discouraging programs, policies, and activities with disproportionately high and adverse human health or environmental effects on minority and low-income populations;
- 27.2.11 Executive Order 13166, Improving Access to Services for Persons with Limited English Proficiency, and resulting agency guidance, national origin discrimination includes discrimination because of limited English proficiency (LEP). To ensure compliance with Title VI, you must take reasonable steps to ensure that LEP persons have meaningful access to your programs (70 Fed. Reg. at 74087 to 74100);

## PROFESSIONAL SERVICES AGREEMENT

27.2.12 Title IX of the Education Amendments of 1972, as amended, which prohibits you from discriminating because of sex in education programs or activities (20 U.S.C. 1681 et seq).

### **SECTION 28. SUBLETTING, ASSIGNMENT, OR TRANSFER**

- 28.1 Any subletting, assignment, or transfer of any professional services to be performed by Consultant is hereby prohibited unless prior written consent of State, on LPA's behalf, is obtained.
- 28.2 At LPA's or State's discretion, Consultant may enter into an agreement with any subconsultants/subcontractors for work covered under this agreement. All subconsultant/subcontractor agreements for work covered under this agreement must contain identical or substantially similar provisions to those in this agreement. No right-of-action against LPA or State will accrue to any subconsultant/subcontractor by reason of this Agreement.
- 28.3 As outlined in SECTION 26. DISADVANTAGED BUSINESS ENTERPRISES, Consultant shall take all necessary and reasonable steps to ensure that disadvantaged business enterprises have the maximum opportunity to compete for and perform subagreements. Any written request to sublet any other services must include documentation of efforts to employ a disadvantaged business enterprise.

### **SECTION 29. CONSULTANT CERTIFICATIONS**

The undersigned duly authorized representative of Consultant, by signing this Agreement, hereby swears, under the penalty of law, to the best of my knowledge and belief, the truth of the following certifications, and agrees as follows:

- 29.1 Neb. Rev. Stat. § 81-1715(1). I certify compliance with the provisions of Section 81-1715 and, to the extent that this Agreement is a lump sum, actual cost-plus-fixed-fee, or specific rates of compensation type professional services agreement, I hereby certify that wage rates and other factual unit costs supporting the fees in this Agreement are accurate, complete, and current as of the date of this Agreement. I agree that the original contract price and any additions thereto shall be adjusted to exclude any significant sums by which State determines the contract price had been increased due to inaccurate, incomplete, or noncurrent wage rates and other factual unit costs.
- 29.2 Neb. Rev. Stat. §§ 81-1717 and 1718. I hereby certify compliance with the provisions of Sections 81-1717 and 1718 and, except as noted below, neither I nor any person associated with the firm in the capacity of owner, partner, director, officer, principal investor, project director, manager, auditor, or any position involving the administration of federal funds:
- Has employed or retained for a commission, percentage, brokerage, contingent fee, or other consideration, any firm or person (other than a bona fide employee working solely for me or the above Consultant) to solicit or secure this Agreement, or
  - Has agreed, as an express or implied condition for obtaining this Agreement, to employ or retain the services of any firm or person in connection with carrying out this Agreement, or
  - Has paid, or agreed to pay, to any firm, organization or person (other than a bona fide employee working solely for me or the above Consultant) any fee, contribution,

PROFESSIONAL SERVICES AGREEMENT

donation, or consideration of any kind for, or in connection with procuring or carrying out this Agreement, except as here expressly stated (if any).

29.3 Certification Regarding Debarment, Suspension, and Other Responsibility Matters- Primary Covered Transactions. Section 29.3a below contains 10 instructions that consultant agrees to follow in making the certifications contained in 29.3b.

a. Instructions for Certification

1. By signing this Agreement, Consultant is providing the certification set out below.
2. The inability of a person to provide the certification required below will not necessarily result in denial of participation in this project. Consultant shall submit an explanation of why it cannot provide the certification set out below. The certification or explanation will be considered in connection with State's determination whether to enter into this Agreement. However, failure of Consultant to furnish a certification or an explanation will disqualify Consultant from participation in this Agreement.
3. The certification in this clause is a material representation of fact upon which reliance was placed when State determined to enter into this Agreement. If it is later determined that Consultant knowingly rendered an erroneous certification, in addition to other remedies available to the Federal government, State may terminate this Agreement for cause or default.
4. Consultant shall provide immediate written notice to State if at any time Consultant learns that its certification was erroneous when submitted or has become erroneous by reason of changed circumstances.
5. The terms "covered transaction," "debarred," "suspended," "ineligible," "lower tier covered transaction," "participant," "person," "primary covered transaction," "principal," "proposal," and "voluntarily excluded," as used in this clause, have the meanings set out in the Definitions and Coverage sections of the rules implementing Executive Order 12549 – Debarment and suspension. Exec. Order No. 12,549, 51 Fed. Reg. 6370 (1986).
6. Consultant agrees that should the proposed covered transaction be entered into, it will not knowingly enter into any lower tier covered transaction with a person who is debarred, suspended, declared ineligible, or voluntarily excluded from participation in this covered transaction, unless authorized by State before entering into this Agreement.
7. Consultant further agrees to include the clause titled "Certification Regarding Debarment, Suspension, Ineligibility and Voluntary Exclusion - Lower Tier Covered Transaction," provided by State without modification, in all lower tier covered transactions and in all solicitations for lower tier covered transactions.
8. Consultant in a covered transaction may rely upon a certification of a prospective Subconsultant in a lower tier covered transaction that it is not debarred, suspended, ineligible, or voluntarily excluded from the covered transaction, unless it knows that the certification is erroneous. A Consultant may decide the method and frequency by which it determines the eligibility of its principals.
9. Nothing contained in the foregoing will be construed to require establishment of a system of records in order to render in good faith the certification required by this clause. The knowledge and information of Consultant is not required to exceed

PROFESSIONAL SERVICES AGREEMENT

that which is normally possessed by a prudent person in the ordinary course of business dealings.

10. Except for transactions authorized under paragraph a.6. of these instructions, if Consultant in a covered transaction knowingly enters into a lower tier covered transaction with a person who is suspended, debarred, ineligible, or voluntarily excluded from participation in this transaction, in addition to other remedies available to the federal government, State may terminate this Agreement for cause or default.

b. Certification Regarding Debarment, Suspension, and Other Responsibility Matters - Primary Covered Transactions

1. By signing this Agreement, Consultant certifies to the best of its knowledge and belief, that it and its principals:
  - a) Are not presently debarred, suspended, proposed for debarment, declared ineligible, or voluntarily excluded from covered transactions by any federal department or agency;
  - b) Have not within a three-year period preceding this Agreement been convicted of or had a civil judgment rendered against them for commission of fraud or a criminal offense in connection with obtaining, attempting to obtain, or performing a public (federal, state, or local) transaction or contract under a public transaction; violation of federal or state antitrust statutes or commission of embezzlement, theft, forgery, bribery, falsification or destruction of records, making false statements, or receiving stolen property;
  - c) Are not presently indicted for or otherwise criminally or civilly charged by a governmental entity (federal, state, or local) with commission of any of the offenses enumerated in paragraph 1.b) above; and
  - d) Have not within a three-year period preceding this Agreement had one or more public transactions (federal, state, or local) terminated for cause or default.
2. Where Consultant is unable to certify to any of the statements in this certification, such Consultant shall attach an explanation to this Agreement. I acknowledge that this certification is to be furnished to State and the FHWA in connection with this Agreement involving participation of federal-aid highway funds and is subject to applicable, state and federal laws, both criminal and civil.

**SECTION 30. LPA CERTIFICATION**

- 30.1 By signing this Agreement, I do hereby certify that, to the best of my knowledge, Consultant or its representative has not been required, directly or indirectly as an express or implied condition in connection with obtaining or carrying out this Agreement to:
  - a. employ or retain, or agree to employ or retain, any firm or person, or
  - b. pay or agree to pay to any firm, person, or organization, any fee, contribution, donation, or consideration of any kind.
- 30.2 I acknowledge that this certification is to be furnished to the FHWA, upon their request, in connection with this Agreement involving participation of Federal-Aid highway funds and is subject to applicable state and federal laws, both criminal and civil.

PROFESSIONAL SERVICES AGREEMENT

**SECTION 31. SEVERABILITY**

The invalidity or unenforceability of any such clause, provision, section, or part shall not affect the validity or enforceability of the balance of the Agreement, which shall be construed and enforced as if the Agreement did not contain such invalid or unenforceable clause, provision, section or part.

**SECTION 32. COMPLETENESS**

This Agreement is the complete and exclusive statement of the arrangement between the parties, and supersedes all proposals, oral or written, and all other communications between the parties relating to the subject matter thereof. It may be amended from time to time in writing by the mutual consent of the Parties hereto.

**SECTION 33. FEDERAL AID REQUIRED CLAUSES**

The contract clauses set out on Exhibit "E", to the extent applicable, are attached and incorporated herein by this reference. Consultant shall attach and incorporate Exhibit "E" in any subconsultant agreements for work under this agreement.

PROFESSIONAL SERVICES AGREEMENT

IN WITNESS WHEREOF, the Parties hereby execute this Agreement pursuant to lawful authority as of the date signed by each party. Further, the Parties, by signing this Agreement, attest and affirm the truth of each and every certification and representation set out herein.

EXECUTED by Consultant this 22<sup>nd</sup> day of May, 2026.

JEO CONSULTING GROUP, INC.  
Jeff Henson

  
\_\_\_\_\_  
President

STATE OF NEBRASKA )  
                                  )ss.  
SAUNDERS COUNTY )

SUBSCRIBED AND SWORN to before me this 22<sup>nd</sup> day of May, 2026

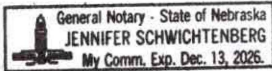

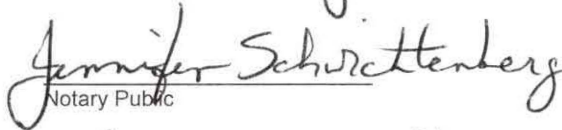
  
\_\_\_\_\_  
Notary Public

EXECUTED by the City of Beatrice this 26 day of May, 2026

CITY OF BEATRICE  
Bob Morgan

  
\_\_\_\_\_  
Mayor

Subscribed and sworn to before me this 26 day of May, 2026

  
\_\_\_\_\_  
Clerk

STATE OF NEBRASKA  
DEPARTMENT OF TRANSPORTATION  
Form of Agreement Approved for  
Federal Funding Eligibility  
Jodi Gibson

  
\_\_\_\_\_  
Local Assistance Division Manager

**RESOLUTION NUMBER \_\_\_\_\_**

**WHEREAS**, the City of Beatrice, Nebraska is an eligible unit of a General Local Government authorized to file an application under the Housing and Community Development Act of 1974, as amended for small City's Community Development Block Grant Program; and

**WHEREAS**, the City of Beatrice was awarded a Four Hundred Thirty-Five Thousand Dollars (\$435,000.00) Community Development Block Grant ("CDBG") from the Nebraska Department of Economic Development ("NDED") for a Downtown Revitalization Project ("23-DTR-002"); and

**WHEREAS**, the City of Beatrice has decided to use the CDBG funds for a Downtown Revitalization Program; and

**WHEREAS**, Hydo Properties, LLC, a Nebraska Limited Liability Company and Todd A. Hydo and Soni Hydo, husband and wife, applied to participate in the Downtown Revitalization Program for their building located at 303 Court Street, Beatrice, Nebraska; and

**WHEREAS**, the City of Beatrice desires to enter into an agreement to loan Sixty-Two Thousand Nine Hundred Eighty-One Dollars and Twenty-Five Cents (\$62,981.25) to Hydo Properties, LLC and Todd A. Hydo and Soni Hydo, as part of the Downtown Revitalization Program and CDBG Grant 23-DTR-002.

NOW, THEREFORE, BE IT RESOLVED BY THE MAYOR AND CITY COUNCIL OF THE CITY OF BEATRICE, NEBRASKA:

**SECTION 1.** That the Mayor, City Attorney, and the City Clerk be authorized to execute the Loan Agreement, Promissory Note, Personal Guaranty, and Deed of Trust between the City of Beatrice and Hydo Properties, LLC and Todd A. Hydo and Soni Hydo, for a direct loan in the amount of Sixty-Two Thousand Nine Hundred Eighty-One Dollars and Twenty-Five Cents (\$62,981.25) from the City's CDBG Downtown Revitalization Grant (23-DTR-002) and to execute

all other documents in accordance with the provisions of the same.

**SECTION 2.** That all resolutions or parts of resolutions in conflict herewith are hereby repealed.

RESOLUTION PASSED AND ADOPTED this 15<sup>th</sup> day of June, 2026.

Attest:

\_\_\_\_\_  
Erin Saathoff, MMC, City Clerk

\_\_\_\_\_  
Robert Morgan, Mayor

**BEATRICE DOWNTOWN REVITALIZATION IMPROVEMENT PROGRAM  
LOAN AGREEMENT  
23-DTR-002**

THIS AGREEMENT dated the \_\_\_\_ day of \_\_\_\_\_, 2026, is entered into by and between Hydo Properties, LLC, a Nebraska Limited Liability Company and Todd A. Hydo and Soni Hydo, husband and wife, (herein after jointly referred to as "Borrower") and City of Beatrice, Nebraska, a Municipal corporation ("Lender").

**WHEREAS**, Lender submitted a Downtown Revitalization ("DTR") application to the Nebraska Department of Economic Development ("DED") for a Community Development Block Grant ("CDBG");

**WHEREAS**, DED approved Lender's application for a DTR grant;

**WHEREAS**, Lender has decided to use the CDBG funds from the DTR grant to implement a Downtown Revitalization Improvement Program; and

**WHEREAS**, Borrower has applied to Lender in participate in the Downtown Revitalization Improvement Program.

**NOW, THEREFORE**, in consideration of the mutual covenants and agreements contained herein, the parties agree as follows:

**PART I: THE LOAN**

**1.01 Purpose of Loan.**

Lender has agreed to lend money to Borrower to make improvements to Borrower's building located at:

Lot Five (5), Block Sixty-Five (65), Beatrice Original Town, now City of Beatrice, Gage County, Nebraska.

Commonly referred to as: 303 Court Street, Beatrice, Nebraska ("Property").

The exact nature and extent of improvements Borrower will make to their Property are set forth in Borrower's application and environmental review. The improvements Borrower will make to their Property shall be hereinafter referred to as the "Project". A copy of Borrower's application and environmental review are attached hereto and incorporated by reference. Borrower agrees that it will use the loan funds received pursuant to this agreement only for the Project.

### **1.02 The Loan, Rate, and Draw Down**

Subject to the terms and conditions of this Agreement, Lender agrees to lend to Borrower, and Borrower agrees to borrow from the Lender the amount of Sixty-Two Thousand Nine Hundred Eighty-One Dollars and Twenty-Five Cents (\$62,981.25) at an interest rate of six point seven five percent (6.75%) per annum.

The disbursement of funds shall be done on a reimbursement basis. Borrower shall have the work for the Project done and then submit invoices and receipts to Lender. Lender will then submit those invoices and receipts to DED and request DED to release the funds. Once the funds have been released by DED and received by Lender, the Lender will then disperse the funds to Borrower. Borrower acknowledges that this disbursement of funds may take sixty (60) to ninety (90) days and that Lender is not required to request reimbursement from DED the same day that Borrower submits their invoices and receipts to Lender. Lender has to right to package or pool reimbursement requests together and submit them to DED on a periodic basis.

### **1.03 The Term and Repayment.**

This Loan and corresponding Promissory Note shall have a term of five (5) years.

If Borrower retains all of the improvements made to the Property as part of the Project for five (5) years then Lender shall forgive the all of the principal and interest due and payable under this Agreement.

If Borrower does not retain all of the improvements made to the Property as part of the Project for five (5) years or if any action by Borrower causes DED to require Lender to repay part or all of the DTR Grant (23-DTR-002) then the entire principal and interest due from Borrower shall by due and payable immediately. Borrower shall have a tenant leasing the Property within six (6) months of completion of work paid for with the funds or Borrower may be responsible to repay all funds received from Lender.

For the purposes of this Agreement, the Borrower's five (5) year clock starts once the Project is complete and the Borrower has received their final disbursement of funds from Lender.

Borrower acknowledges that there may be tax consequences if this loan is forgiven; and that Borrower has had an opportunity to consult their tax advisor.

### **1.04 Security Position.**

Borrower shall execute a Promissory Note, Personal Guaranty, and Deed of Trust on property owned by Borrower naming Lender as Beneficiary. Said property is commonly referred to as 303 Court Street, Beatrice, Nebraska.

## **PART II: REPRESENTATIONS AND WARRANTIES.**

Borrower represents and covenants the following:

### **2.01 Duly Organized.**

Borrower has the power to enter into this Agreement and to borrow.

### **2.02 Duly Authorized.**

The making and performance by Borrower of this Agreement, and the execution and delivery of the Promissory Note in a form satisfactory to Lender (the "Note" or "Promissory Note"), a Personal Guaranty, and a Deed of Trust have been duly authorized by all necessary action and will not violate any law, rule, regulation, order, writ, judgment, decree, determination or award presently in effect having applicability to Borrower or result in a breach of or constitute a default under any indenture or bank loan or credit agreement or any other agreement or instrument to which Borrower is a party or by which it or its property may be bound or affected.

### **2.03 Legally Binding Instruments.**

When this Agreement is executed by Borrower and Lender, and when the Note are executed and delivered by Borrower, each such instrument will constitute the legal, valid, and binding obligation of Borrower in accordance with its terms. Any security agreements and instruments, financing statements, deeds of trust, mortgages, personal guaranty, and other liens on chattel or real estate will constitute legal, valid and binding liens.

### **2.04 No Legal Suits.**

There are no legal actions, suits, or proceedings pending or, to the knowledge of Borrower, threatened against Borrower before any court or administrative agency, which if determined adversely to Borrower, would have a material adverse effect on the financial condition or business of Borrower.

### **2.05 No Legal Authorization Needed.**

No authorization, consent or approval, or any formal exemption of any Governmental body, regulatory authorities (federal, state, or local) or mortgagee, creditor or third party, is or was necessary for the valid execution and delivery by Borrower of this Agreement.

### **2.06 Not in Default.**

Borrower is not in default of any obligation, covenant, or condition contained in any bond, debenture, note, or other evidence of indebtedness or any mortgage or collateral instrument securing the same.

### **2.07 Taxes Are Paid.**

Borrower has filed all tax returns which are required and has paid or made provision for the payment of all taxes which have or may become due pursuant to said returns or pursuant to any assessments levied against Borrower or its personal or real property by any taxing agency, federal, state or local. No tax liability has been asserted by the Internal Revenue Service or other taxing agency, federal, state, or local for taxes materially in excess of those already provided for and Borrower knows of no basis for any such deficiency assessment.

### **2.08 No Adverse Change.**

Borrower certifies that there has been no adverse or material change since the date of the loan application in the financial condition, organization, operating, business prospects, fixed properties, or personnel of Borrower.

## **PART III. CONDITIONS OF LENDING.**

The obligation of Lender to make the Loan will be subject to the fulfillment at the time of closing of each of the following conditions:

### **3.01 Execution and delivery of Note and Loan Agreement.**

Borrower will have executed and delivered to Lender this Loan Agreement, the Promissory Note, and Personal Guaranty in a form satisfactory to Lender and its Counsel.

### **3.02 Execution and Delivery of Other Documents.**

Borrower will have executed and delivered to Lender the Promissory Note, Deed of Trust, and Personal Guaranty.

### **3.03 Omitted on Purpose.**

### **3.04 Omitted on Purpose.**

### **3.05 Governmental Approval.**

Borrower will have secured all necessary approvals or consents, if required, of Governmental bodies or agencies having jurisdiction with respect to any construction contemplated in accordance with the use of proceeds of the loan.

### **3.06 Approval of Others.**

Borrower will have secured all necessary approvals or consents required with respect to this transaction by any mortgagor, creditor, or other party having any financial interest in Borrower.

#### **PART IV: AFFIRMATIVE COVENANTS OF BORROWER.**

Borrower agrees to comply with the following covenants from this date until Lender has been fully repaid with interest, unless Lender or its Assigns otherwise consent in writing:

##### **4.01 Payment of the Loan.**

Borrower agrees to pay punctually the principal and interest on the Note according to the terms and conditions and to pay punctually any other amounts that may become due and payable to Lender pursuant to the terms of this Agreement.

##### **4.02 Payment of Other Indebtedness.**

Borrower agrees to pay punctually the principal and interest due on any other indebtedness now or at any time owing by Borrower to Lender or any other lender.

##### **4.03 Maintain and Insure Property.**

Borrower agrees at all times to maintain the property provided as security for this Loan in such condition and repair that Lender's security will be adequately protected. Borrower also agrees to maintain during the term of the Loan adequate hazard insurance policies covering fire and extended coverage and such other hazards as may be deemed appropriate in amounts and form sufficient to prevent Borrower from becoming a co-insurer and issued by companies satisfactory to Lender with an acceptable loss payee clause in favor of Lender.

##### **4.04 Pay All Taxes.**

Borrower agrees to duly pay and discharge all taxes, assessments and governmental charges upon it or against its properties prior to the date on which penalties are attached, except that Borrower will not be required to pay any such tax, assessment or governmental charge which is being contested by it in good faith and by appropriate proceedings.

##### **4.05 Omitted on Purpose.**

##### **4.06 Provide Financial Information.**

Borrower agrees to maintain adequate records and books of account, in which complete entries will be made reflecting all of its business and financial transactions, such entries to be made in accordance with generally accepted principles of good accounting practice consistently applied in the case of financial transactions.

Borrower agrees to provide financial information, and execute and deliver any and all additional documents and instruments as may be reasonably requested by Lender, its assigns or counsel, within thirty (30) calendar days of being requested.

Borrower further agrees to provide written notice to Lender of any public hearing or meeting before any administrative or other public agency which may, in any manner, affect the chattel, personal property or real estate securing the loan.

#### **4.07 Right to Inspection.**

Borrower agrees to grant to Lender until the Note has been fully repaid with interest the right at all reasonable hours to inspect the Collateral used to secure the Loan; and Borrower further agrees to provide Lender free access to Borrower's premises for the purpose of such inspection to determine the condition of the real estate.

#### **4.08 Null and Void Covenants.**

Borrower agrees that in the event that any provision of this Loan Agreement or any other instrument executed at closing or the application to any person or circumstances will be declared null and void, invalid, or held for any reason to be unenforceable by a Court of competent jurisdiction, the remainder of such agreement will nevertheless remain in full force and effect, and to this end, the provisions, of all covenants, conditions, and agreements described herein are deemed separate.

#### **4.09 Closing Costs.**

Borrower agrees to pay all fees, expenses and charges with respect to the loan, or its making or transfer to the Lender in any way connected including, but not limited to, the fees and out-of-pocket expenses of local counsel employed by Lender, title insurance, and survey costs, recording and filing fees, mortgage taxes, documentary stamp tax and any other taxes, fees and expenses payable in connection with this transaction and with the enforcement of this Agreement and Note.

#### **4.10 Notice of Default.**

Borrower agrees to give written notice to Lender of any event, within fifteen (15) business days of the event, which constitutes an Event of Default under this Loan Agreement as described in Article VI or that would, with notice or lapse of time or both, constitute an Event of Default under this Loan Agreement.

#### **4.11 Indemnification.**

Borrower agrees to indemnify and save Lender or its Assigns harmless against any and all liability with respect to, or resulting from, any delay in discharging any obligation of Borrower to this Agreement or the transactions contemplated hereby or from any aspect of the Project.

#### **4.12 Expenses of Collection or Enforcement.**

Borrower agrees, if at any time Borrower defaults on any provision of this Loan Agreement, to pay to Lender in addition to any other amounts that may be due from Borrower, an amount equal to the costs and expenses of collection, enforcement or correction or waiver of the default incurred by Lender or its successors and assigns in such collection, enforcement, correction or waiver of default.

#### **4.13 Omitted on Purpose.**

#### **4.14 Compliance With Law.**

Evidence satisfactory to Lender will be furnished certifying that all improvements and their use comply fully with all applicable zoning and building laws, ordinances and regulations, and all other applicable federal, state and municipal law requirements. The loan will be in all respects legal and will not violate any applicable law or other requirements of any governmental authority.

#### **4.15 Environmental Protection Laws.**

Receipt of evidence satisfactory to Lender of compliance with all applicable environmental protection and land use and development laws, ordinances and regulations of all federal, state and local governmental authorities and agencies having jurisdiction.

#### **4.16 Omitted on Purpose.**

#### **4.17 Omitted on Purpose.**

#### **4.18 Omitted on Purpose.**

### **PART V: NEGATIVE COVENANTS OF BORROWER.**

Borrower covenants and agrees that, from this date until payment in full of the Note, unless Lender or its successors and assigns otherwise consent in writing, it will not enter into any agreement or other commitment the performance of which would constitute a breach of any of the covenants contained in this Loan Agreement including, but not limited to the following covenants:

### **5.01 Encumber the Pledged Assets.**

Borrower will neither create nor suffer to exist any new mortgage, pledge, lien, charge or encumbrance, including liens arising from judgments, on the property provided as security for this loan which is superior to the claims and/or liens of Lender.

### **5.02 Change Ownership.**

The principals of Borrower will not permit without the written permission of Lender any material change in the ownership, structure, control, or operation of Borrower or Property including but not limited to (a) merger into or consolidation with any other person, firm or corporation; (b) changing the nature of its business as carried out at the date hereof; (c) changing the nature of its business as carried out at the date hereof; (d) substantial distribution, liquidation or other disposal of Borrower's assets to the members; and (e) changing the ownership of the Property. Should any material change in the ownership, structure, control, or operation of Borrower or Property occur, Lender reserves the right to renegotiate this Agreement pursuant to Section 7.02, or declare the entire unpaid principal of the Note and the accrued interest immediately due and payable upon written demand of Lender or their assigns.

## **PART VI: EVENTS OF DEFAULT.**

The entire unpaid principal of the Note and the accrued interest will become and be immediately due and payable upon the written demand of Lender, except where noted, without any other notice or demand of any kind of any presentment or protest, if any one of the following events (an "Event of Default") occurs and continues at the time of such demand, whether voluntarily or involuntarily, or without limitation, occurring or brought about by operation of law or pursuant to or in compliance with any judgment, decree or order of any court or any order, rules or regulation of any administrative or governmental body, provided, however, that such sum will not be then payable if Borrower's payments have been waived, or the time for making Borrower's payments has been extended by Lender.

### **6.01 Nonpayment of Loan.**

If Borrower fails to make payment when due of any installment of principal on the Note or accrued interest and if the default remains unremedied for thirty (30) calendar days after written notice thereof.

### **6.02 Nonpayment of Other Indebtedness.**

If default is made in the payment when due of any installment of principal or of interest on any of Borrower's other indebtedness and if such default remains unremedied for thirty (30) calendar days after written notice thereof.

### **6.03 Incorrect Representation or Warranty.**

Any representation or warranty contained in, or made in connection with the execution and delivery of, this Loan Agreement, or Grant Application or in any provided information proves to be incorrect.

### **6.04 Default in Covenants.**

Borrower will default in the performance of any other term, covenant or agreement contained in this Loan Agreement, and such default continues unremedied for thirty (30) calendar days after either: i) it becomes known to an executive officer of Borrower; or ii) written notice has been given to Borrower by Lender.

### **6.05 Voluntary Insolvency.**

If Borrower becomes insolvent or ceases to pay its debts as they mature or voluntarily files a petition seeking reorganization of its business, or the appointment of a receiver, trustee, of liquidation of a substantial portion of its assets effects a plan or other arrangement with creditor's, or be adjudicated bankrupt, or make a voluntary assignment for the benefit of creditors.

### **6.06 Involuntary Insolvency.**

If an Involuntary petition is filed against Borrower under any bankruptcy, insolvency or similar law or seeking the reorganization of or the appointment of any receiver, trustee or liquidate for Borrower, or of a substantial part of the property of Borrower, or a writ or warrant of attachment or similar process will be issued against a substantial part of the property of Borrower, and such petition is not dismissed, or such writ or warrant of attachment or similar process is not released or bonded, within thirty (30) calendar days after filing or levy.

### **6.07 Omitted on Purpose.**

## **PART VII: MISCELLANEOUS**

### **7.01 Waiver of Notice.**

No failure or delay on the part of Lender in exercising any right, power, or remedy hereunder will operate as a waiver thereof, nor will any single or partial exercise of any such right, power, or remedy preclude any other or further exercise thereof or the exercise of any other right, power or remedy hereunder. No modification or waiver of any provision of this Loan Agreement or of the Notes, nor any consent to same will be effective unless it is in writing and then such waiver or consent will be effective only in the specific instance and for the specific purpose for which given. No notice to or demand on Borrower in any case will entitle Borrower to any other or further notice or demand in similar or other circumstances.

## **7.02 Amendments.**

Borrower and Lender or its Assigns reserves all rights to amend any provisions of this Agreement, to consent to or waive any departure from the provisions of this Loan Agreement, to amend or consent to or waive departure from the provisions of the Note and to release or otherwise deal with any collateral security for payment of the Note provided, all such amendments must be in writing and executed by Lender or its Assigns, and Borrower.

## **7.03 Notices.**

All notices, consents, requests, demands and other communication will be in writing and will be deemed to have been duly given to a party if mailed to the Lender at 400 Ella Street, Beatrice, Nebraska 68310, and to Borrower at PO Box 5, Beatrice, NE 68310.

## **7.04 Survival of Representations and Warranties.**

All agreements, representations, and warranties made by Borrowers or any other documents or certificate delivered to the Lender in connection with the transactions contemplated by this Loan Agreement will survive the delivery of this Agreement, the Note and the Security Agreement, and will continue in full force and effect so long as the Note is outstanding.

## **7.05 Successors and Assigns.**

This Loan Agreement will be binding upon Borrower, its Successors, and Assigns. Borrower may not assign or transfer its rights without prior written consent of Lender.

## **7.06 Counterparts.**

This Loan Agreement may be executed in any number of counterparts, each of which will be deemed an original, but all of which together will constitute one and the same instrument.

## **7.07 Governing Law.**

This Loan Agreement, the Note, Personal Guaranty, and the Deed of Trust will be deemed contracts made under the laws of the State of Nebraska and for all purposes will be construed in accordance with the laws of this State.

## **7.08 Article and Section Headings.**

Article and Section headings used in the Agreement are for convenience only and will not affect the construction of this Agreement.

**7.09 Effective Agreement.**

This agreement, together with the Note, Personal Guaranty, Deed of Trust, application or agreement incorporated herein by reference, comprises the complete and integrated agreement of the parties with regard to the subject matter hereof and supersedes all prior agreements, written or oral, with regard to the subject matter hereof.

IN WITNESS WHEREOF, the parties hereto have each caused this Loan Agreement to be executed.

LENDER:  
THE CITY OF BEATRICE,  
NEBRASKA, a Municipal  
Corporation

BORROWER:  
Hydo Properties, LLC,  
a Nebraska Limited Liability Company

BY: \_\_\_\_\_  
Robert Morgan, Mayor

BY: T.A. Hydo  
Todd A. Hydo, Member

\_\_\_\_\_  
DATE

6.5.2026  
\_\_\_\_\_  
DATE

Attest:  
  
\_\_\_\_\_  
Erin Saathoff, City Clerk

BORROWER:  
Todd A. Hydo, individually  
T.A. Hydo  
Todd A. Hydo

BORROWER:  
Soni Hydo, individually  
Soni Hydo  
Soni Hydo

STATE OF NEBRASKA        )  
  ) ss.  
COUNTY OF GAGE         )

The foregoing instrument was acknowledged before me on this 5 day of June, 2026 by Todd A. Hydo, Member of Hydo Properties, LLC, to be his voluntary act and deed on behalf of said company.

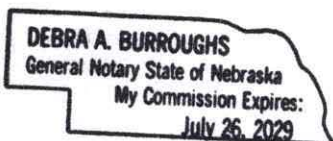

Debra A Burroughs  
Notary Public

STATE OF NEBRASKA        )  
  ) ss.  
COUNTY OF GAGE         )

The foregoing instrument was acknowledged before me on this 5 day of June, 2026 by Todd A. Hydo, to be his voluntary act and deed.

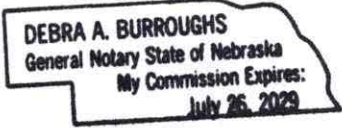

Debra A Burroughs  
Notary Public

STATE OF NEBRASKA        )  
  ) ss.  
COUNTY OF GAGE         )

The foregoing instrument was acknowledged before me on this 5 day of June, 2026 by Soni Hydo, to be her voluntary act and deed.

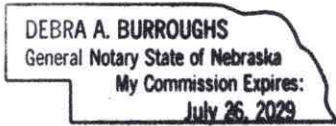

Debra A Burroughs  
Notary Public

**PROMISSORY NOTE  
TODD A. HYDO AND SONI HYDO  
DOWNTOWN REVITALIZATION IMPROVEMENT PROGRAM**

\$62,981.25

Beatrice, Nebraska

For Value Received, the undersigned, Hydo Properties LLC, a Nebraska Limited Liability Company, and Todd A. Hydo and Soni Hydo, husband and wife, (all jointly hereafter known as the "Borrower"), promises to pay to the City of Beatrice, Nebraska, a Municipal Corporation, (the "Lender"), the principal sum of Sixty-Two Thousand Nine Hundred Eighty-One Dollars and Twenty-Five Cents (\$62,981.25), together with interest accruing at the rate of six point seven five percent (6.75%) per annum on the remaining principal balance.

Interest shall begin to accrue immediately upon the first drawdown of funds as set forth in the Loan Agreement, marked as Exhibit "A" attached hereto.

As set forth in the Loan Agreement, the Borrower shall pay interest and principal payments to Lender.

All payments and any notice to the City of Beatrice will be made at 400 Ella Street, Beatrice, Nebraska, 68310, or such other address as designated to the Borrower in writing. Any notice to the Borrower, will be given to the Borrower at the following address: PO Box 5, Beatrice, Nebraska, 68310, or at such other address as the Borrower will have designated to the Lender in writing.

This debt may be prepaid in whole or in part at any time, without penalty or fee.

This Note is to be secured by the Loan Agreement, attached hereto and marked as Exhibit "A", and a Personal Guaranty of Todd A. Hydo and Soni Hydo and is subject to any additional terms therein.

It is agreed that if there is a default in the payment of this Note after written notice thereof to Borrower or if default is made under the terms of the Loan Agreement, then, at the option of the Lender, the principal sum, with accrued interest, shall become immediately due and payable.

It is further understood and agreed that, in the event of sale or a material change in the ownership of the Borrower, then this Note shall immediately become due and payable.

The undersigned:

- (a) Waives demand, presentment, protest, notice of protest, suit against any party and all other requirements necessary to hold it;
- (b) Agrees to pay after default all costs of collecting or attempting to collect this note, including reasonable attorneys' fees; and
- (c) Waives as to this debt or any renewal or extension, or of any part, all rights of exemption under the constitution or laws of the State of Nebraska or any other state as to personal property.

This Note and all provisions are binding on the Borrower, its successors and assigns, and will inure to the benefit of the Lender, its successors and assigns. The Lender does not by any act, delay, omission or otherwise waive any of its rights or remedies, and no waiver of any kind is valid against the Lender unless in writing and signed by the Lender.

This note is governed and construed in accordance with the laws of the State of Nebraska.

Sixty-Two Thousand Nine Hundred Eighty-One Dollars and Twenty-Five Cents (\$62,981.25) of the principal amount hereof results from a Downtown Revitalization Improvement Loan made to Borrower pursuant to a Loan Agreement, dated \_\_\_\_\_, 2026, among the Lender and Borrower, which Loan Agreement is attached hereto as Exhibit "A".

Dated and executed on this \_\_\_\_\_ day of \_\_\_\_\_, 2026.

LENDER:  
THE CITY OF BEATRICE,  
NEBRASKA, a Municipal  
Corporation

BORROWER:  
HYDO PROPERTIES, LLC  
a Nebraska Limited Liability Company

BY: \_\_\_\_\_  
Robert Morgan, Mayor

BY: [Signature]  
Todd A. Hydo

Attest:

[Signature]  
Todd A. Hydo

\_\_\_\_\_  
Erin Saathoff, City Clerk

[Signature]  
Soni Hydo

STATE OF NEBRASKA     )  
  ) ss.  
COUNTY OF GAGE         )

The foregoing instrument was acknowledged before me on this 5 day of June, 2026 by Todd A. Hydo, Member of Hydo Properties, LLC, to be his voluntary act and deed on behalf of said limited liability company.

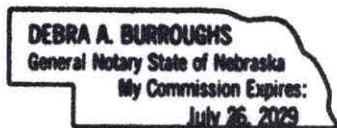

[Signature]  
Notary Public

STATE OF NEBRASKA )  
 ) ss.  
COUNTY OF GAGE )

The foregoing instrument was acknowledged before me on this 5 day of June, 2026 by Todd A. Hydo, to be his voluntary act and deed.

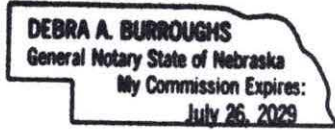

Debra A Burroughs  
Notary Public

STATE OF NEBRASKA )  
 ) ss.  
COUNTY OF GAGE )

The foregoing instrument was acknowledged before me on this 5 day of June, 2026 by Soni Hydo, to be her voluntary act and deed.

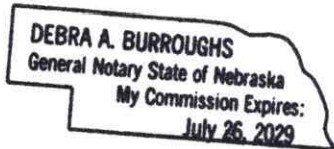

Debra A Burroughs  
Notary Public

**RESOLUTION NUMBER \_\_\_\_\_**

**WHEREAS**, on September 20, 2024, the Community Redevelopment Authority of the City of Beatrice, Nebraska (the "Authority") and City of Beatrice, Nebraska ("Redeveloper") entered into a Redevelopment Agreement (the "Agreement") for the Lincoln School Redevelopment Project (the "Project") in Redevelopment Area No. 11; and

**WHEREAS**, on or about March 17, 2025, the Premises was replatted; and

**WHEREAS**, on or about May 9, 2025, the Authority and Redeveloper executed the First Amendment to the Redevelopment Agreement to amend the legal description of the Premises included in the Redevelopment Agreement; and

**WHEREAS**, on or about December 5, 2025, the Authority and Redeveloper executed the Second Amendment to the Redevelopment Agreement to modify the Effective Date of the Redevelopment Project, and to modify the amount of the Series A and Series B TIF Notes for the project; and

**WHEREAS**, the Authority and Redeveloper desire to amend the Redevelopment Agreement to modify the anticipated Effective Date of the Redevelopment Project; and

**WHEREAS**, pursuant to Section 18-2117 of the Act, the Authority does not consider the modification to substantially change the Redevelopment Plan as previously approved by the City.

NOW, THEREFORE, BE IT RESOLVED BY THE MAYOR AND CITY COUNCIL OF THE CITY OF BEATRICE, NEBRASKA:

**SECTION 1.** That the Mayor and City Clerk are hereby authorized to execute the Third Amendment to Redevelopment Agreement, attached hereto as Exhibit "A" and incorporated by reference.

**SECTION 2.** That all resolutions or parts of resolutions in conflict herewith are hereby repealed.

RESOLUTION PASSED AND ADOPTED this 15<sup>th</sup> day of June, 2026.

Attest:

---

Erin Saathoff, MMC, City Clerk

---

Robert Morgan, Mayor

**THIRD AMENDMENT TO REDEVELOPMENT AGREEMENT  
(LINCOLN SCHOOL REDEVELOPMENT PROJECT)**

This Third Amendment to Redevelopment Agreement ("Second Amendment") dated this \_\_\_\_ day of June, 2026 is entered into by and between the Community Redevelopment Authority of the City of Beatrice ("CRA") and the City of Beatrice, Nebraska, a municipal corporation ("Redeveloper").

**RECITALS**

- A. The CRA and Redeveloper entered into a Redevelopment Agreement dated September 20, 2024 ("Redevelopment Agreement").
- B. On or about March 17, 2025, the Premises was replatted.
- C. On or about May 9, 2025, the CRA and Redeveloper executed the First Amendment to the Redevelopment Agreement to amend the legal description of the Premises included in the Redevelopment Agreement.
- D. On or about December 5, 2025, the CRA and Redeveloper executed the Second Amendment to the Redevelopment Agreement to modify the Effective Date of the Redevelopment Project, and to modify the amount of the Series A and Series B TIF Notes for the project.
- E. The CRA and Redeveloper desire to amend the Redevelopment Agreement to modify the anticipated Effective Date of the Redevelopment Project.

NOW THEREFORE, in consideration of mutual promises contained herein and in the Redevelopment Agreement, the parties agree to amend the Redevelopment Agreement as follows:

- 1. Section 1.01(F).
  - a. Section 1.01(F) is hereby deleted and restated as follows:

"F. "Effective Date" Effective Date" means the date to begin dividing taxes. Each phase of the Project shall have a separate Effective Date. Subject to the terms and conditions of Section 3.01 and any permitted changes to the projected construction schedule, the Effective Date for Phase One of the Project is anticipated to be January 1, 2027, with a base year of 2026. The Effective Dates for subsequent phases will be determined prior to undertaking a new phase, and shall be conclusively determined based upon the filing of the Notice to Divide Taxes for each subsequent phase."

This Third Amendment to Redevelopment Agreement is effective as of the date reflected in the first paragraph above.

THE COMMUNITY REDEVELOPMENT  
AUTHORITY OF THE CITY OF BEATRICE,  
NEBRASKA

ATTEST:

\_\_\_\_\_  
Craig Zarybnicky, Secretary

By: \_\_\_\_\_  
Doug Kennedy, Chairman

**"REDEVELOPER"**  
City of Beatrice, Nebraska,  
a Nebraska municipal corporation, Grantor

\_\_\_\_\_  
Robert Morgan, Mayor

STATE OF NEBRASKA            )  
  ) ss.  
COUNTY OF GAGE             )

The foregoing instrument was acknowledged before me this \_\_\_\_ day of \_\_\_\_\_, 2026, by Robert Morgan, Mayor and authorized signatory for the City of Beatrice, Nebraska, a Nebraska municipal corporation, to be his voluntary act and deed on behalf of the City of Beatrice, Nebraska.

\_\_\_\_\_  
Notary Public

**RESOLUTION NUMBER \_\_\_\_\_**

**WHEREAS**, on September 20, 2024, the Community Redevelopment Authority of the City of Beatrice, Nebraska (the "Authority") and City of Beatrice, Nebraska ("Redeveloper") entered into a Redevelopment Agreement (the "Agreement") for the Paddock Lane Redevelopment Project (the "Project") in Redevelopment Area No. 12; and

**WHEREAS**, on or about March 17, 2025, the Premises was replatted; and

**WHEREAS**, on or about May 9, 2025, the Authority and Redeveloper executed the First Amendment to the Redevelopment Agreement to amend the legal description of the Premises included in the Redevelopment Agreement; and

**WHEREAS**, on or about December 5, 2025, the Authority and Redeveloper executed the Second Amendment to the Redevelopment Agreement to modify the Effective Date of the Redevelopment Project, and to modify the amount of the Series A and Series B TIF Notes for the project; and

**WHEREAS**, the Authority and Redeveloper desire to amend the Redevelopment Agreement to modify the anticipated Effective Date of the Redevelopment Project; and

**WHEREAS**, pursuant to Section 18-2117 of the Act, the Authority does not consider the modification to substantially change the Redevelopment Plan as previously approved by the City.

NOW, THEREFORE, BE IT RESOLVED BY THE MAYOR AND CITY COUNCIL OF THE CITY OF BEATRICE, NEBRASKA:

**SECTION 1.** That the Mayor and City Clerk are hereby authorized to execute the Third Amendment to Redevelopment Agreement, attached hereto as Exhibit "A" and incorporated by reference.

**SECTION 2.** That all resolutions or parts of resolutions in conflict herewith are hereby repealed.

RESOLUTION PASSED AND ADOPTED this 15<sup>th</sup> day of June, 2026.

Attest:

---

Erin Saathoff, MMC, City Clerk

---

Robert Morgan, Mayor

Exhibit "A"

**THIRD AMENDMENT TO REDEVELOPMENT AGREEMENT  
(PADDOCK LANE REDEVELOPMENT PROJECT)**

This Third Amendment to Redevelopment Agreement ("Second Amendment") dated this \_\_\_\_ day of June, 2026 is entered into by and between the Community Redevelopment Authority of the City of Beatrice ("CRA") and the City of Beatrice, Nebraska, a municipal corporation ("Redeveloper").

**RECITALS**

- A. The CRA and Redeveloper entered into a Redevelopment Agreement dated September 20, 2024 ("Redevelopment Agreement").
- B. On or about March 17, 2025, the Premises was replatted.
- C. On or about May 9, 2025, the CRA and Redeveloper executed the First Amendment to the Redevelopment Agreement to amend the legal description of the Premises included in the Redevelopment Agreement.
- D. On or about December 5, 2025, the CRA and Redeveloper executed the Second Amendment to the Redevelopment Agreement to modify the Effective Date of the Redevelopment Project, and to modify the amount of the Series A and Series B TIF Notes for the project.
- E. The CRA and Redeveloper desire to amend the Redevelopment Agreement to modify the anticipated Effective Date of the Redevelopment Project.

NOW THEREFORE, in consideration of mutual promises contained herein and in the Redevelopment Agreement, the parties agree to amend the Redevelopment Agreement as follows:

1. Section 1.01(F).

- a. Section 1.01(F) is hereby deleted and restated as follows:

"F. "Effective Date" Effective Date" means the date to begin dividing taxes. Each phase of the Project shall have a separate Effective Date. Subject to the terms and conditions of Section 3.01 and any permitted changes to the projected construction schedule, the Effective Date for Phase One of the Project is anticipated to be January 1, 2027, with a base year of 2026. The Effective Dates for subsequent phases will be determined prior to undertaking a new phase, and shall be conclusively determined based upon the filing of the Notice to Divide Taxes for each subsequent phase."

This Third Amendment to Redevelopment Agreement is effective as of the date reflected in the first paragraph above.

THE COMMUNITY REDEVELOPMENT  
AUTHORITY OF THE CITY OF BEATRICE,  
NEBRASKA

ATTEST:

\_\_\_\_\_  
Craig Zarybnicky, Secretary

By: \_\_\_\_\_  
Doug Kennedy, Chairman

**"REDEVELOPER"**  
City of Beatrice, Nebraska,  
a Nebraska municipal corporation, Grantor

\_\_\_\_\_  
Robert Morgan, Mayor

STATE OF NEBRASKA            )  
  ) ss.  
COUNTY OF GAGE             )

The foregoing instrument was acknowledged before me this \_\_\_\_ day of \_\_\_\_\_, 2026, by Robert Morgan, Mayor and authorized signatory for the City of Beatrice, Nebraska, a Nebraska municipal corporation, to be his voluntary act and deed on behalf of the City of Beatrice, Nebraska.

\_\_\_\_\_  
Notary Public



**STAKE  
YOUR  
CLAIM**

# **BEATRICE**

CITY • BOARD OF PUBLIC WORKS

## CITY ADMINISTRATOR'S MONTHLY REPORT JUNE 2026

CAPITAL PROJECTS	1
PLANNING & ZONING	5
ECONOMIC DEVELOPMENT	5
EMPLOYEE	6
FINANCIALS	6
CODE VIOLATIONS / BUILDING PERMITS / DEMOLITIONS	6
PUBLIC PROPERTIES	6
STORM SEWER/DRAINAGE	7
STREETS	7
UTILITIES	8
SPECIAL DESIGNATED LICENSES and SELLING/PEDDLING GOODS REQUESTS	10
COMPLETED CAPITAL PROJECTS	10

## CAPITAL PROJECTS

### DEVELOPMENT OF CORRAL CROSSING AND HERITAGE HEIGHTS:

A master plan has been approved. Bid was awarded to Van Kirk Brothers Contracting on May 5<sup>th</sup> for the installation of storm sewer, sanitary sewer, street paving, and grading for Corral Crossing Addition and Heritage Heights Addition. Utility work at Corral Crossing is complete and electrical has been installed. Utility work at Heritage Heights is complete. Installation of electrical at Heritage Heights will start soon.

**Funding:** LB840/Street/Util **Est. Cost:** TBD **Amt Spent as of 4/30/26:** \$3,192,587 **Est. Completion:** 2026

### CAST INITIATIVE:

The City was awarded a \$21.3 million RAISE Grant. A Program Agreement has been signed with NDOT. JEO was selected as the engineer for the project. Grant Agreement has been signed. *Preliminary design has started. Plan in hand meeting is scheduled for August 17<sup>th</sup>.*

**Funding:** Grant **Est. Cost:** TBD **Amt Spent as of 4/30/26:** \$0 **Est. Completion:** 2031

### COMPREHENSIVE PLAN:

Updated Comprehensive Plan for the City. Grant Agreement signed March 4, 2026. *Contract with Confluence has been signed. Pre-kickoff meeting was held.*

**Funding:** General/Grant **Est. Cost:** \$75,000 **Amt Spent as of 4/30/26:** \$0 **Est. Completion:** 2027

### DEMPSTERS:

The City has budgeted \$200,000 annually. The City has acquired the main buildings and should acquire the last parcel this fall. Asbestos removal is complete. The Street Department, with the help of six (6) part-time employees, worked on cleaning up the Dempster's property. The Street Department hauled a total of 146 total dump truck loads of brush, construction rubble, and garbage from the site. MARS also hauled approximately twelve (12) rollofs during the cleanup. Awaiting grant announcement.

**Funding:** General **Est. Cost:** TBD **Amt Spent as of 4/30/26:** \$168,582 **Est. Completion:** Years

### TAXIWAY C and APRON RECONSTRUCTION:

Bid was awarded on June 3, 2024 to Vogts Parga Construction in the amount of \$5,660,502.12. Airport was awarded FAA Airport Improvement Program (AIP) grant of \$4,810,000.00. The project duration is anticipated to be one hundred eighty-two (182) days and will be broken into four (4) phases, allowing the Airport to stay open during construction. Construction began May 5<sup>th</sup>, with a tentative completion date of November 2, 2025. Phase 1 began on May 5<sup>th</sup> and was completed on July 3, 2025, twenty-one (21) days behind schedule due to the Contactor not securing the required base aggregate for the Phase 1 paving and a few days for rain. Phase 2 started on July 4<sup>th</sup> and was completed on October 4<sup>th</sup>. Phase 2 ended up being twenty-two (22) days behind schedule, putting the whole project forty-three (43) days behind schedule at that point. The entire project is ninety-six (96) days behind schedule as of February 6, 2026. A Substantial Completion date was documented as of February 6, 2026. 100LL fuel was received in the new tank on February 9<sup>th</sup> and the Nebraska State Fire Marshall approved the operation of the new system on February 19, 2026. A final walk-through inspection was conducted on February 25, 2026, with a final project punch list compiled and submitted to Vogts Parga. Punch list items are currently being worked on. Vogts Parga is contesting their liquidated damages.

**Funding:** Airport **Est. Cost:** \$6,245,177 **Amt Spent as of 4/30/26:** \$5,704,959 **Est. Completion:** Spring 2026

### T-HANGAR and TAXILNE CONSTRUCTION:

Plans are being made to construct a 10-unit T-Hangar along with reconstruct/rehabilitate surrounding hangar approaches/taxilanes. Senator Fischer secured \$2,850,000 for a new hangar. Benesch recommended the contract be awarded to Vogts Parga and the City Council approved that recommendation on April 7, 2025. The

Federal grant will cover 95%, the State grant will cover 2% and the remaining 3% is our local share, estimated to be \$82,554.86. Federal funds were finally released, and the Hangar Grant Agreement was signed and returned on August 25<sup>th</sup>. The contract was awarded to Vogts Parga on April 7, 2025 however the bid hold period was exceeded due to the delayed release of federal funds. Vogts Parga declined to honor the original bid and increased the projected cost by \$277,000.00. It was determined that it was in our best interest to reject the increased cost and rebid the project. On the rebid, we received four (4) bids with AHRS Construction being the low bidder at \$2,260,852. Bid was awarded to AHRS Construction on December 15<sup>th</sup>. Pre-construction meeting was held March 9, 2026. Construction started on April 20, 2026.

**Funding:** Grant/Airport **Est. Cost:** \$3,310,000 **Amt Spent as of 4/30/26:** \$218,633 **Est. Completion:** Fall 2026

#### **NAVIGATIONAL AIDS (NAVAIDs) UPGRADE:**

The existing Precision Approach Path Indicator (PAPI) system for Runway 36 is reaching the end of its useful life. Plans are being made to remove the existing PAPI on Runway 36 and replace it with a new 4-Light PAPI system on Runways 18 & 36. The project will also include installing new 2-Light PAPIs on Runways 14 & 32. In addition to the PAPIs a new Runway End Identifier Lights (REILs) system will be added to Runway 18. 95/5 Grant. Pre-design conference was held on November 10, 2025. Project was advertised on February 28, 2026 with bid opening scheduled for March 19, 2026. Contract was awarded to Danielle's Approach. Project anticipated to start summer 2026. *Pre-construction meeting is scheduled for June 15<sup>th</sup>.*

**Funding:** Grant/Bonds **Est. Cost:** \$382,000 **Amt Spent as of 4/30/26:** \$218,633 **Est. Completion:** Fall 2026

#### **EMS AMBULANCE:**

*The ambulance is in service.*

**Funding:** CARES **Est. Cost:** \$450,000 **Amt Spent as of 4/30/26:** \$0 **Est. Completion:** Spring 2026

#### **COMMUNICATION EQUIPMENT:**

Replacement of Base Radio, Communications Work Station, Enterprise Records, and Radio Consoles. A \$782,000 congressional appropriation was secured by Senator Fischer. *Awaiting grant documents.*

**Funding:** Fischer Grant **Est. Cost:** \$584,000 **Amt Spent as of 4/30/26:** \$0 **Est. Completion:** Fall 2026

#### **DRONE:**

Drone w/night vision capabilities and equipment. A total of \$4,000 in donations have been received.

**Funding:** Private/General **Est. Cost:** \$25,000 **Amt Spent as of 4/30/26:** \$0 **Est. Completion:** 2026

#### **HANNIBAL PARK IMPROVEMENTS – 2026:**

Public Properties staff is working on cleaning up around the area where the new field will be installed. The trees and asphalt parking lot was removed by the Street Department the week of January 5<sup>th</sup>. Dirt work for Field 8 is out for bid and due back March 26, 2026. Two (2) bids were received and Clausen & Sons Dirt Work was awarded the bid in the amount of \$115,215.00 on April 6, 2026. Concession stand remodel is completed at Hannibal Park. The Beatrice Girls Softball Association donated the money for this project to be accomplished.

**Funding:** Lodging/PR/Grant **Est. Cost:** \$287,000 **Amt Spent as of 4/30/26:** \$17,835 **Est. Completion:** Fall 2026

#### **FOREST MANAGEMENT PLAN:**

IRA Community Forestry Grant for Forest Mgt Plan and tree planting/removal. Nineteen (19) trees were removed at Hannibal Park. Eight (8) more are scheduled to be removed at the Water Park and Dog Park. Nineteen (19) trees were planted at Hannibal Park on May 4<sup>th</sup>.

**Funding:** Grant **Est. Cost:** \$140,000 **Amt Spent as of 4/30/26:** \$39,499 **Est. Completion:** Ongoing

**RCRP GRANT:**

The City received \$955,000 in grant funding for various park improvements:

**Heritage Heights:** New Playground. Two (2) bids were received on November 13, 2025. Bid was awarded to Play-Pro Recreation, LLC, in the amount of \$250,000 on November 17, 2025. The playground equipment has been installed. Sidewalks are being installed around the structure for easy access. Once sidewalks are completed, the artificial turf will be installed to finish out the playground.

**Stoddard:** New Playground. One (1) bid was received from Play-Pro Recreation, LLC, in the amount of \$198,808, which was awarded on December 15, 2025. The dirt work is completed at Stoddard Park and is ready for the contractor to install the playground. The equipment has arrived and is on site.

**HOMESTEAD TRAIL:**

Grant 80/20 split with State + \$550,000 for National Park Service. Design is underway. Bid is anticipated in January 2027 with construction in 2027. Approved Plan-In-Hand on October 7, 2024. Environmental review is in progress.

**Funding:** Lodging **Est. Cost:** \$2.5m **Amt Spent as of 4/30/26:** \$0 **Est. Completion:** Summer 2027

**DUCK POND IMPROVEMENTS:**

Remove silt or change channel and clean up. Met with local tree contractors for removal of trees around the Duck Pond. Public Properties is continuing tree removal as time permits. *Awaiting federal approval to remove dam.*

**Funding:** Keno **Est. Cost:** \$50,000 **Amt Spent as of 4/30/26:** \$0 **Est. Completion:** Summer 2027

**INDUSTRIAL PARK DISTRIBUTION LINE IMPROVEMENTS:**

This project will include both, rebuilding existing lines to allow for increased loading in the Industrial Park, and the addition of new lines to better serve the existing loads and for new customer loads in the future. Two (2) sections of a main feeder line from Substation #2 were replaced and upgraded from the corner of Ashland and Shugart to the south side of the Accuma plant. This project was done in conjunction with upgrades being made for the south Exmark service.

**Funding:** Bond/Utility **Est. Cost:** \$551,000 **Amt Spent as of 4/30/26:** \$0 **Est. Completion:** Fall 2026

**POWER GENERATION FACILITY:**

HDR has completed their study in different technologies, lead times, and permitting. Meeting with various entities who may be potential partners. HDR is preparing bid documents.

**Funding:** Bonds **Est. Cost:** \$1m **Amt Spent as of 4/30/26:** \$0 **Est. Completion:** Fall 2026

**SUBSTATION #2 IMPROVEMENTS:**

Replace the substation transformer with a larger size, increase the footprint of the substation to accommodate the new control building, and install a new breaker and control lineup in the building. Bond funding has been secured. This work is being done to allow a larger substation transformer to be installed along with a switchgear lineup that will be able to support the larger loads we are forecasting due to additions to existing companies and new customers. The initial layout and groundwork are being done to allow for drainage improvements and the new equipment.

**Funding:** Bonds/Utility **Est. Cost:** \$1.01m **Amt Spent as of 4/30/26:** \$0 **Est. Completion:** Fall 2026

**SUBSTATION #7 IMPROVEMENTS:**

Substation #7 was originally built to provide 4.16Kv voltage on the distribution feeders. The area that this substation provided service to has all been converted to 12.5Kv. This project will include the installation of a

new transformer and breaker lineup that will serve the area at the 12.5Kv voltage level. The transformer for this project has been ordered, and it should be received early this fall.

**Funding:** Bonds      **Est. Cost:** \$1.28m      **Amt Spent as of 4/30/26:** \$0      **Est. Completion:** Fall 2026

**SUBSTATION #9 IMPROVEMENTS:**

This will include upsizing the existing bus bar to allow for the installation of an additional feeder to increase the total load capacity that we are able to export from this substation. We are currently working on material specifications and quantities for this project. We will be sending the information out for quotes in the near future.

**Funding:** Bonds/Utility      **Est. Cost:** \$414,000      **Amt Spent as of 4/30/26:** \$0      **Est. Completion:** Fall 2026

**WATER MAIN PROJECT – HAYES TO HIGH:**

Replace 6" water main. The Engineering Department has conducted a topographical survey of the area. Line work based on the survey has been created. *Engineering Department has performed a topo graphical survey of the area and plans are currently being created.*

**Funding:** Infra Funds      **Est. Cost:** \$60,000      **Amt Spent as of 4/30/26:** \$0      **Est. Completion:** Summer 2026

**WATER MAIN PROJECT – NORTH 7<sup>TH</sup>, GRANT TO GARFIELD:**

Replace 8" water main. The Water Department started site work during the last week in April. *The boring contractor completed pipe installation during the last two (2) weeks of May. Work will be ongoing for several weeks for this project, as we continue to tie-in the new main with existing mains, run tests and samples, and transfer services to the new main.*

**Funding:** Infra Funds      **Est. Cost:** \$180,000      **Amt Spent as of 4/30/26:** \$0      **Est. Completion:** Summer 2026

**GRIT CONSTRUCTION:**

Design and Installation of the new Grit process equipment and building. Received grant with help of Congressman Smith in the amount of \$2 million. Letter Agreement with Olsson, Inc., entered into on November 21, 2022 for the design process. Bids were received on April 10, 2025 for the construction of the project. The EPA has authorized the City to award this project. The contract was awarded to Building Crafts, Inc., on June 2<sup>nd</sup>. BCI Construction continues to install the new Grit Building. Pre-cast walls and roof panels are in place. *Internal drainage piping in the truck bay has been installed and the concrete flooring for both levels has been installed. The concrete basins on the outside of the building have been poured and tested. Wall joints have been filled with backer-rod and sealed. Currently working on the primary clarifier feed lines.*

**Funding:** Grant/Util      **Est. Cost:** \$3.9m      **Amt Spent as of 4/30/26:** \$1,740,806      **Est. Completion:** 2026

**SCADA DESIGN:**

Contract for engineering services has been created and approved by the City Council. A letter Agreement with Olsson, Inc., was entered into on November 21, 2022. A project kickoff meeting was conducted on January 23, 2023. Final Specifications and drawings have been submitted and approved by the City of Beatrice. Drawings and specifications will be sent to NDEE for review and approval. The project will coincide with the Grit Improvement project. A fiber backbone is being installed to select buildings for connection to the new SCADA system and HOA has begun the installation of the SCADA system.

**Funding:** Utility      **Est. Cost:** \$35,000      **Amt Spent as of 4/30/26:** \$0      **Est. Completion:** Fall 2025

**ELLA STREET, 2<sup>nd</sup> to 3rd:**

Seven (7) bids were received on October 30, 2025. R.L. Tiemann was the low bidder with a total of \$426,609.15 and was awarded the contract, with a completion date of June 1, 2026. Tiemann began construction on April 20<sup>th</sup>. During April the brick roadway and associated sidewalk were removed. Change Order #1 decrease in the

amount of \$3,036.37 was approved May 4<sup>th</sup>. VanKirk, a subcontractor, has completed the installation of the new storm sewer system. R.L. Tieman has replaced the subgrade for the concrete pavement as directed by the City Engineer. Concrete roadway pavement and parking stalls have been completed. Concrete driveways and sidewalks have been the main focus, which is currently 90% complete. Coordination efforts with the Electric Department and the Public Properties Department have been done to complete their portions of the project. Final grading and landscaping will be conducted during the next month.

**Funding:** Street **Est. Cost:** \$486,667 **Amt Spent as of 4/30/26:** \$37,001 **Est. Completion:** Spring 2026

### **7<sup>TH</sup> STREET CONCRETE RECONSTRUCTION, ARTHUR TO MONROE:**

A topographical survey of the area has been conducted by the Engineering Department. The design phase of the project has been initiated by the Engineering Department. The project was awarded to R.L. Tiemann Construction on May 4<sup>th</sup> in the amount of \$429,262.40. The project began on June 1<sup>st</sup>, with Gana, a subcontractor, being onsite performing the concrete removals. All property owners affected by either tree removal or the concrete sidewalk being relocated have been contacted. Letters were sent to all adjacent property owners informing them that the alleys should/will be used to access their property and for trash pickup services. Van Kirk, another subcontractor, will be moving onto the site to perform the storm sewer improvements.

**Funding:** Street **Est. Cost:** \$375,000 **Amt Spent as of 4/30/26:** \$0 **Est. Completion:** Fall 2026

### **ARMOR COATING VARIOUS LOCATIONS**

Plans and Specifications were created by the Engineering Dept. The project was sent out for bids during the month of November 2025. Two (2) bids were received on December 4, 2025. Sta-Bilt was the low bidder with a total of \$33,317.20 and was awarded the contract with a completion date of August 1, 2026. The contractor is anticipated to be on site June 10<sup>th</sup>- 12<sup>th</sup> to perform the work. Information and no parking letters have been sent to the adjacent property owners.

**Funding:** Street **Est. Cost:** \$33,317 **Amt Spent as of 4/30/26:** \$0 **Est. Completion:** Fall 2026

### **ASPHALT SEALING VARIOUS LOCATIONS**

Plans and Specifications were created by the Engineering Dept. The project was sent out for bids during the month of November 2025. One (1) bid was received on December 4, 2025. Hall Brothers was the low bidder with a total of \$29,007.24 and was awarded the contract with a completion date of August 1, 2026.

**Funding:** Street **Est. Cost:** \$29,007 **Amt Spent as of 4/30/26:** \$0 **Est. Completion:** Fall 2026

## **PLANNING & ZONING**

The Planning and Zoning Commission (P&Z) recommended to the City Council to rezone real estate legally described as: Outlot B, Homestead Junction Second Addition to the City of Beatrice, Gage County, Nebraska, Parcel No. 012409603, from General Industrial District "GI" to General Commercial District "GC". P&Z also recommended to the City Council approval of the Final Plat Application request by Homestead Junction, LLC, to replat a portion of their property as Homestead Junction Third Addition.

## **ECONOMIC DEVELOPMENT**

### **Recent TIF Activity:**

The Northgate Campus Redevelopment Project is working its way through the TIF process.

### **LB840 Loans:**

All existing LB840 loans are current. The program income for FY26 as of April 30, 2026 is \$701,861. The current unexpended funds as of April 30, 2026 total \$577,881, and those funds are deposited in Pinnacle Bank.

## EMPLOYEE

### **Safety:**

During the month of May, there were no workers comp claims filed. We currently have no employees on modified duty due to a worker's comp claim.

### **Retirement:**

Wayne Rickers retired from the Water Department, again, on June 5<sup>th</sup>.

## FINANCIALS

Financial statements for the General and Street Fund for the month ending April 30, 2026, are attached, marked as **Exhibit "A"**. Financial statements for the Electric, Water, and WPC Departments for the month ending April 30, 2026, are attached, marked as **Exhibit "B"**.

## CODE VIOLATIONS / BUILDING PERMITS / DEMOLITIONS

### **Code Violations:**

Code Compliance Officer responded to and worked on one hundred forty (140) various code violations in May, bringing the year-to-date total to four hundred (400). A total of seventy-one (71) cases were closed in May, bringing the total year-to-date closed cases two two hundred forty-one (241). There are currently one hundred fifty-five (155) open cases. See attached list, marked as **"Exhibit C"**.

### **Building Permits:**

Processed thirty-five (35) permits/applications/inquiries, bringing the year-to-date total to one hundred ninety-nine (199). See attached list, marked as **"Exhibit D"**.

### **Demolitions:**

A list of demolition projects is attached, marked as **"Exhibit E"**.

## PUBLIC PROPERTIES

- Big Blue Waterpark is up and running smoothly at this time.
- Beatrice Girls Softball will be hosting a district tournament from 6/5 thru 6/7 at Hannibal Park.
- Staff have been working on Homestead Trail between Beatrice and Cortland repairing washouts on the trails and removing fallen trees.
- Staff installed a new activator button on the Sertoma-Astro splash pad last week.
- Beatrice Bullets baseball held tournaments the past two (2) weekends at Scott Street ballfield.

## STORM SEWER/DRAINAGE

1. MS4: JEO was hired to update the City of Beatrice MCM#5 – Post Construction Stormwater section of the Stormwater Management Plan. City code was amended December 15, 2025, to match the Drainage Criteria Plan. The 2025 Annual report was prepared and submitted to NDWEE on March 30, 2026.

## STREETS

### **Sweeping:**

We swept a total of nine (9) days with both sweepers.

### **Gravel Streets:**

We bladed gravel streets and alleys for seven (7) days to bring gravel back onto the roadway that may have washed off in storms.

### **Mosquitos:**

The crew attended the annual mosquito spraying conference in Lincoln. Each year our sprayer is calibrated at this time.

### **Sign Work:**

We worked a total of four (4) days replacing faded or leaning signs.

### **Street Painting:**

Painting has begun for the year. It will take us approximately one (1) month of good weather to complete all of the painting of lines, curbs, skips, symbols, and crosswalks.

### **Concrete repairs:**

We have started making repairs around town. We patched for a total of six (6) days. Patching will go on into the fall.

### **Asphalt repairs:**

We have begun making repairs on asphalt streets. Currently, we are patching streets that will be armor coated this summer. Asphalt patching will last until cold weather.

### **Trimming trees:**

We trimmed trees and hauled brush for four (4) days after storms.

### **Police Department Firing Range:**

We removed trees and old fencing around the range. We also bladed the road and constructed and rocked a new parking lot.

### **Mowing Highways:**

We mowed a total of ten (10) days on Highway 77 on the north and south sides of town.

### **Pothole Patching:**

We patched one (1) day using 850 pounds of patching material.

### **UTILITY DELINQUENT NOTICES and DISCONNECTIONS:**

There were 1,142 disconnect notices mailed out in May. There was a total of 60 disconnections for non-payment on June 4<sup>th</sup>.

### **Overhead Distribution:**

The distribution line between 6<sup>th</sup> and 7<sup>th</sup> Streets, Summit to Monroe, is in the process of being upgraded. The line is being completely rebuilt and will then be converted to our 12.5Kv distribution voltage level. The crew is currently working on the new pole installations. *The new poles, crossarms, and insulators have been installed. The crew is currently preparing to pull in the new conductors.* We also continue to work on the line at 19<sup>th</sup> and Jefferson Street and have begun rebuilding this line south of Jefferson Street, from 19<sup>th</sup> to 22<sup>nd</sup> Street. This line is also in back yards with no alley access. *The line at 19<sup>th</sup> and Jefferson to 22<sup>nd</sup> Street has been completely rebuilt. All the old poles, conductors, and transformers have been removed. This section is complete.*

We are also working on rebuilding a line on Hill Street. This line also runs on Bismark Street, from Hill to N. Sumner Street. This line is being completely rebuilt due to the condition of the poles and conductors. The crew is currently working on framing and setting the new poles. *The new poles and hardware on Bismark Street, from Hill to Wiebe, have been set and the conductors installed and energized. The crew is currently working on the tap lines that extend extending to the north and south of Bismark.*

### **Underground Distribution:**

We have trenched in all the conduit for the primary distribution lines, set junction boxes, and set transformers for the Corral Crossing development. The high voltage distribution lines have been pulled in and terminated at the transformers. We need to bore one (1) street crossing yet and then this portion will be complete. We have also started installing streetlights for this area.

We are also working on the design and layout of several other new developments which will all be underground extensions. These include the Heritage Heights development, the Beatrice Commons development, and the new AG Building at SCC.

### **Street Light Project, 2<sup>nd</sup> and Ella:**

*In conjunction with the street reconstruction project on Ella Street, between 2<sup>nd</sup> and 3<sup>rd</sup> Streets, we have begun installing decorative streetlights. The concrete bases have all been poured and the conduit has been extended from the bases to beyond the construction limits. We are working on setting the decorative poles and finishing the conduit extensions to power the lights.*

### **Substation Maintenance**

We have begun testing and maintenance of the voltage regulators on the substation transformers. This is being done to ensure that they operate properly and efficiently during the summer loading season. We are also inspecting and confirming the proper operation of the substation line breakers at several substation.

### **Substation Control and Data Acquisition Projects:**

There were two (2) projects started under our SCADA system. The first one (1) was to upgrade our main data collection equipment at the Service Center that communicates with all the substations and collects our load data and alarms. The installation of this equipment is complete and now we are looking at converting the communications over to the fiber lines installed by Pinpoint. We are currently working on extending pinpoint fiber into our substations for secure communications and future upgrades. Conduits have been extended from

pinpoints junction boxes into our substation control buildings. Pinpoint has begun to terminate the fiber lines in the substation buildings. The fiber has been extended into all the substation buildings and Pinpoint has finished terminating and installing all the connecting equipment.

The second project is a distribution automation project that combines functions of our AMI system and the SCADA system. Utilizing the AMI communication network, we are able to install remotely operated controls on our capacitor banks to allow our SCADA system to turn them on and off when needed according to the substation loads. This is an expandable project where we will be able to install and monitor controls and equipment on the distribution lines utilizing our existing systems. Work continues on installing the remote equipment at the capacitor bank sights and rewiring the controls for remote operation.

**Water Service Leaks and Service Calls:**

- 1609 Court Street - Replace yoke

**Water Main Replacement/Construction:**

*The Water Department used a large portion of May to work on the construction of the 7<sup>th</sup> Street main replacement.*

**Water Main Breaks:**

*Investigated a report of a water main break near the intersection of Garden and Grove, however, no main break was discovered.*

**Maintenance and Miscellaneous Work:**

We are continuing to exercise main valves as often as possible.

We are in the midst of testing backflows as well. The City has approximately 450 backflow devices, which the Department tests and repairs annually. We are currently on schedule with our backflow tests.

**Installed service taps at:**

- 1306 South 8<sup>th</sup> Street
- 1308 South 8<sup>th</sup> Street
- 200 block of Ella - BCHHC Garden
- 200 block of Ella - City of Beatrice Public Properties (1)
- 200 block of Ella - City of Beatrice Public Properties (2)

*Removed a damaged sample site at 4<sup>th</sup> and Washington Street.*

*Began repairs for the pressure sustaining valve on Blue Ridge Road. This will be a specialized repair that will be conducted in the coming weeks*

**Sewer Line Maintenance/Blockages:**

We had three (3) sewer calls this month.

- 409 S 9<sup>th</sup> Street - Not on the city
- 2704 Ella Street - Not on the city
- 415 N 18<sup>th</sup> Street - Not on the city

### Sanitary Sewer Lining:

Johnson Services of Kearney was contracted to perform sanitary sewer lining service for the 2025 and 2026 fiscal year. They were in town and lined approximately 584 linear feet of 8-inch and 584 linear feet of 10-inch. A change order has been approved to perform two-point repairs at service connections, rehab two (2) manholes and line 383 linear feet of 10-inch. This work will be performed this upcoming month.

### Jet Truck Footage:

Daily maintenance for the entire month was 16,555 ft. Monthly maintenance for the month was 4,290 ft.

### TV/Camera Trailer Inspections:

Approximately 5,755 linear feet of new lines were videoed and auto coded with the new SewerAI software.

During a normal video inspection of a city sanitary sewer main, two (2) fiber optic lines were discovered bored through our pipe. Pinpoint was contacted and agreed to pay for the repairs to have them removed. The area is located 70' south of Brown Street and Court Street. *This is scheduled to be repaired this month.*

### Lift Stations:

Lift Station No. 8 and 9 were vac'd and cleaned.

### Plant Maintenance:

- Plant maintenance is up to date at the WPC Plant.
- Centrifuge Maintenance: Due to the high rainfall events, bio-solids processing required extra effort towards maintenance on the centrifuges.
- North Final Clarifier: Was taken out of service and drained for maintenance.

## SPECIAL DESIGNATED LICENCES (SDL) and SELLING/PEDDLING GOODS REQUESTS

A list of special designated licenses (SDL) and selling/peddling goods requested for 2026 is attached, marked as "Exhibit F".

## COMPLETED CAPITAL PROJECTS

### 33<sup>RD</sup> AND LINCOLN STREET - COMPLETED

FY24: \$3m ; FY25: \$1m

Contract for design services was awarded to JEO on May 15, 2023. Seven (7) bids were received on April 23, 2024. The apparent low bidder was Constructors of Lincoln, NE with an estimated bid of \$2.3 million. Contract was awarded May 6, 2024. 33<sup>rd</sup> Street is open to traffic. The project was extended west approximately fifty feet (50'). A final walk thru of the project was conducted on November 12, 2024. Final payment scheduled for January 20, 2025.

**Funding:** Street    **Est. Cost:** \$4.3m    **Amt Spent as of 9/30/25:** \$2,851,718    **Est. Completion:** Fall 2024

### LINCOLN STREET, 25<sup>TH</sup> TO 27<sup>TH</sup> - COMPLETED

Contract for design services was awarded to JEO on August 5, 2024. Ten (10) bids were received on February 20, 2025. Project was awarded to M.E. Collins Contracting Co., Inc., in the amount of \$554,222.30. A pre-construction meeting was held on May 13, 2025. Lincoln Street was closed, and construction began on May 27, 2025. The project is complete, and a final walk thru was conducted on September 10, 2025.

**Funding:** Street    **Est. Cost:** \$107,000    **Amt Spent as of 4/30/26:** \$711,321    **Est. Completion:** Fall 2025

### **WATERMAIN – OVERHEAD CROSSING – COURT STREET BRIDGE – COMPLETED**

Replace overhead crossing on Court Street bridge and bore under the river. Entered into a Master Agreement Work Order #2 with Olsson on October 21, 2024. Bid was awarded to Judds Brothers Construction in the amount of \$415,000.00 on June 2, 2025. Judds Brothers has completed the majority of this project, the only remaining items to be completed is final grading and seeding, which will take place in early October; and the Water Department will remove a hydrant from the old main on the east side of the River. Otherwise, the pipe was filled, samples taken and passed, and the main has been put into operation.

**Funding:** Bonds    **Est. Cost:** \$500,000    **Amt Spent as of 4/30/26:** \$511,785    **Est. Completion:** Fall 2025

### **20 YARD REAR LOAD GARBAGE TRUCK - COMPLETED**

Replace 20 yard rear load garbage truck. Truck was delivered the week of September 2<sup>nd</sup>.

**Funding:** Utility    **Est. Cost:** \$275,000    **Amt Spent as of 11/30/25:** \$218,000    **Est. Completion:** Fall 2025

### **LIFT STATION #6 + BACKUP GENERATOR - COMPLETED**

Back-up generator will be installed. Design will be completed in FY24, with construction following shortly thereafter. A project kickoff meeting was conducted October 25, 2023. The Engineering Department has completed the topographical survey and submitted the information to the design engineer. Olsson, Inc., designer engineer, has submitted 90% drawings and specifications for review. Project drawings and specifications were approved by the City and NDEE. Project was sent out for bids and a bid opening was conducted on May 15, 2024. The apparent low bidder was Philip Carkoski Construction of Loup City, Nebraska with a bid of \$547,785.00. The project began on April 29, 2025. Pumps and piping are installed and in operation. Final items to be completed include training and start up services. It is estimated the project will be completed within the next two (2) weeks. Contractor has achieved substantial completion, and the lift station is now back in control by the WPC. Olsson has created a punch list of items that need to be completed or rectified in order for the contractor to achieve final completion. Contractor achieved final completion after addressing all of the punch list items as of October 2, 2025.

**Funding:** Utility    **Est. Cost:** \$700,000    **Amt Spent as of 4/30/26:** \$629,535    **Est. Completion:**

### **RCRP GRANT - COMPLETED**

**Pickleball:** Contract was awarded July 7, 2025 to Lottman Excavating in the amount of \$82,160. Construction is underway. Public Properties staff finished with the pickleball seating area. The handrails were installed and new four-foot (4') fencing was installed for better viewing of the courts. The area was also fine graded and seeded.

**Froberry Park:** Bid was awarded April 21, 2025 to Play-Pro Recreation, LLC, in the amount of \$167,162. The new playground has been installed and is open to the public.

**Chautauqua Park:** New Playground. One (1) bid was received on May 22, 2025. Bid was awarded to Play-Pro Recreation, LLC, in the amount of \$200,586.00 on June 2, 2025. The playground installation is complete and open to the public.

### **4<sup>TH</sup> and 5<sup>TH</sup> STREET, MARKET TO ELLA - COMPLETED**

The bid opening was held on June 26, 2025. R.L. Tiemann was the low bidder with a total of \$98,921.68 for both bid sections. The contract was awarded at the July 7<sup>th</sup> Council Meeting. The project has reached final completion status. Sealing of the concrete pavement joints in the parking areas and curbing was completed on November 8th. Cleaning and sealing the colored concrete sidewalk areas will be done at a later date by the Public Properties Department.

**Funding:** Grants    **Est. Cost:** \$550,000    **Amt Spent as of 4/30/26:** \$120,375    **Est. Completion:** Fall 2025

### **SERTOMA ASTRO PARK ADA PLAYGROUND - COMPLETED**

Install ADA compliant playground. The contractor finished the poured in play matting at Sertoma-Astro Park. Then staff completed final grading and seeding of the park.

**Funding:** Grant **Est. Cost:** \$160,000 **Amt Spent as of 4/30/26:** \$159,488 **Est. Completion:** Fall 2025

### **FIRE HOSE REPLACEMENT - COMPLETED**

Training has been completed. All fire hoses and nozzles have been switched out and in service.

**Funding:** Grants **Est. Cost:** \$14,000 **Amt Spent as of 4/30/26:** \$139,020 **Est. Completion:** Fall 2025

### **WATER PARK DESIGN STUDY - COMPLETED**

RFQ was issued in February 2025. Four (4) responses were received. An Agreement for Professional Services between the City and Waters Edge Aquatic Design to develop an Aquatic Park Master Plan was awarded May 19, 2025. The first public meeting on this project was held on September 10, 2025. The second public meeting was held on October 22, 2025. Waters Edge presented their recommendations to the Council on February 2, 2026. City Council adopted Aquatic Master Plan February 17, 2026.

**Funding:** Lodging **Est. Cost:** \$250,000 **Amt Spent as of 4/30/26:** \$15,150 **Est. Completion:** Fall 2025

### **DESIGN and CONSTRUCTION OF NEW LANDFILL - COMPLETED**

#### Cell Construction:

Awarded bid for the cell construction to Pruss Excavation Co., in the amount of \$6.2 million. Final walk through has been completed. Waiting for permit approval by the State.

#### South MSW Landfill Site Entrance Facility:

Bid was awarded to Genesis Contracting Group on January 6, 2025 in the amount of \$4,052,00. Final walk through has been completed.

**Funding:** BASWA **Est. Cost:** \$10.3 mill **Amt Spent as of 4/30/26:** \$11,658,161 **Est. Completion:** Fall 2025

### **24" VALVE AT FARM WELLS - COMPLETED**

Purchase and install a 24" butterfly valve between farm wells, to allow for more redundancy and the ability to use wells and transmission lines as intended. All materials arrived during the month of February. The Water Department installed this valve during the last week in March and is now operational.

**Funding:** Infra Funds **Est. Cost:** \$60,000 **Amt Spent as of 4/30/26:** \$17,167 **Est. Completion:** Fall 2026

### **CHLORINE BUILDING - COMPLETED**

Construct a new building to house our chlorine disinfectant operations. ACCO installed the system in March. The State and JEO completed their inspections in late March. We passed the inspections and received our approval to put the system into service. The Water Department crew completed our calculations for use and within a few days had the system pretty well dialed in.

**Funding:** Utility **Est. Cost:** \$40,000 **Amt Spent as of 4/30/26:** \$94,454 **Est. Completion:** Summer 2026

FUND	FUND BALANCE 10/1/2025	REVENUE	TRNSFR IN	TOTAL AVAILABLE	EXPEND.	TRNSFR OUT	FUND BALANCE 4/30/2026
<b>GENERAL ALL-PURPOSE FUNDS</b>							
GENERAL	\$ 4,914,104	\$ 6,720,824	\$ -	(5) \$ 11,634,928	\$ 7,944,123	\$ -	(3) \$ 3,632,765
<i>moves to (from)restricted</i>	\$ -		\$ -	(2)		\$ 58,039	(1)
<i>Restricted Gas Plant</i>	\$ 700,000		\$ -	(1) \$ 700,000			XX \$ 700,000
<i>Designated CARES f/future eq</i>	\$ 290,300		\$ -	(1) \$ 290,300		\$ -	(2) \$ 290,300
<i>Designated EMS Equip</i>	\$ 348,323		\$ -	(1) \$ 348,323		\$ -	(2) \$ 348,323
<i>Designated Lodging Tax Proj</i>	\$ 443,762		\$ 58,039	(1) \$ 501,802		\$ -	(2) \$ 501,802
<b>SPECIAL REVENUE:</b>							
Street*	\$ 5,345,488	\$ 2,679,077		\$ 8,024,565	\$ 3,889,031	\$ 155,992	\$ 3,979,542
<i>Restricted Debt Serv</i>	\$ 31,128		\$ 155,992	\$ 187,120			\$ 187,120
Keno	\$ 519,743	\$ 67,553		\$ 587,296	\$ 11,082	\$ -	(4) \$ 576,214
<b>DEBT SERVICE</b>							
GO Debt	\$ 2,987,560	\$ 891,017		\$ 3,878,577	\$ 1,071,959		\$ 2,806,618
Special Assess.-Unbonded	\$ 20,620	\$ 466		\$ 21,086	\$ -		\$ 21,086
<b>CAPITAL PROJECTS</b>							
Capital Improvement	\$ 145,505	\$ 536,035	\$ -	(3) \$ 681,539	\$ 701,746		\$ (20,207)
Capital Imp.-Keno	\$ (0)	\$ -	\$ -	(4) \$ (0)	\$ 5,689		\$ (5,689)
Capital Imp.-Public Safety	\$ 309,073	\$ 330,481	\$ -	(3) \$ 639,554	\$ 878,723		\$ (239,169)
<b>General All-Purpose Fund</b>	<u>\$ 16,055,604</u>	<u>\$ 11,225,453</u>	<u>\$ 214,031</u>	<u>\$ 27,495,089</u>	<u>\$ 14,502,353</u>	<u>\$ 214,031</u>	<u>\$ 12,778,704</u>
<b>RESTRICTED FUNDS</b>							
<b>SPECIAL REVENUE:</b>							
Airport*	\$ 1,075,801	\$ 3,081,087	\$ -	\$ 4,156,888	\$ 3,614,742		\$ 542,146 manual entry
CDBG*	\$ (447,770)	\$ 522,321		\$ 74,551	\$ 98,208		\$ (23,657)
Economic Development*	\$ 149,955	\$ 701,861	\$ -	\$ 851,816	\$ 358,879	\$ (84,944)	\$ 577,881
<i>Restricted Debt Serv</i>	\$ 168,758		\$ (84,944)	\$ 83,814			\$ 83,814
911 Service Surcharge	\$ 140,471	\$ 63,062		\$ 203,533	\$ -	\$ -	(5) \$ 203,533
CRA	\$ -	\$ 145,614		\$ 145,614	\$ 38,504		\$ 107,110
Sanitation*	\$ 305,825	\$ 2,286,235		\$ 2,592,060	\$ 2,294,706	\$ (110,616)	\$ 407,970 manual entry
<i>Restricted Debt Serv</i>	\$ 155,916		\$ (110,616)	\$ 45,300			\$ 45,300
<b>INTERNAL SERVICE</b>							
Employee Benefit Acct	\$ 620,845	\$ 3,502,654		\$ 4,123,499	\$ 2,615,574		\$ 1,507,925
Info Tech Services	\$ -	\$ 628,782		\$ 628,782	\$ 513,186		\$ 115,596
<b>ENTERPRISE</b>							
Board of Public Works*	\$ 20,934,668	\$ 15,544,120		\$ 36,478,788	\$ 17,525,098		\$ 18,953,690 manual entry
Norcross/Horner	\$ 6,978	\$ -		\$ 6,978	\$ -		\$ 6,978
<b>TOTAL RESTRICTED</b>	<u>\$ 23,111,447</u>	<u>\$ 26,475,736</u>	<u>\$ (195,560)</u>	<u>\$ 49,391,623</u>	<u>\$ 27,058,898</u>	<u>\$ (195,560)</u>	<u>\$ 22,528,286</u>
<b>TOTAL</b>	<u>\$ 39,167,051</u>	<u>\$ 37,701,190</u>	<u>\$ 18,471</u>	<u>\$ 76,886,712</u>	<u>\$ 41,561,251</u>	<u>\$ 18,471</u>	<u>\$ 35,306,990</u>

\*cash basis

Exhibit "A"

Exhibit "A"  
**CITY OF BEATRICE, NEBRASKA**  
**GENERAL FUND BUDGETARY STATEMENTS**  
**FOR THE CURRENT YEAR TO DATE**

**AS COMPARED TO THE PRIOR TWO FISCAL YEARS**

DESCRIPTION	PRIOR YEAR 2 ACTUAL FY2024	PRIOR YEAR 1 ACTUAL FY2025	Current as of 4/30/2026	CURRENT YEAR BUDGET FY2026	% YTD
<b>GENERAL REVENUES</b>					
TAXES	7,200,663.51	7,417,491.31	<b>3,254,033.75</b>	7,746,500.00	42.01%
LICENSES & PERMITS	156,065.63	180,450.32	<b>210,984.40</b>	201,300.00	104.81%
INTERGOVERNMENTAL REVENUE	2,422,881.54	2,389,145.82	<b>1,025,819.77</b>	1,803,516.00	56.88%
CHARGES FOR SERVICES	2,782,998.98	2,761,871.03	<b>1,890,946.01</b>	3,192,944.00	59.22%
MISCELLANEOUS REVENUES	1,062,907.38	652,891.35	<b>339,039.93</b>	565,100.00	60.00%
OTHER FINANCING SOURCES	63,100.44	65,801.12	<b>0.00</b>	86,155.00	0.00%
<b>TOTAL REVENUES</b>	<b>13,688,617.48</b>	<b>13,467,650.95</b>	<b>6,720,823.86</b>	<b>13,595,515.00</b>	<b>49.43%</b>
<b>GENERAL EXPENDITURES BY TYPE</b>					
PERSONAL SERVICES	9,285,811.04	10,062,465.28	<b>6,089,936.17</b>	11,110,071.00	54.81%
OTHER SERVICES & CHARGES	1,419,868.56	1,448,138.48	<b>1,104,322.75</b>	1,629,949.00	67.75%
SUPPLIES	456,530.46	513,537.17	<b>250,497.47</b>	523,385.00	47.86%
CAPITAL OUTLAYS	687,521.74	243,284.03	<b>284,113.40</b>	253,221.00	112.20%
CONTINGENCY	7,334.50	122,704.77	<b>2,332.50</b>	122,000.00	1.91%
CONTRACTUAL SERVICES	463,255.03	675,961.73	<b>212,920.75</b>	284,066.00	74.95%
INTERFUND TRANSFERS	933,600.98	1,569,128.48	<b>0.00</b>	1,252,200.00	0.00%
<b>TOTAL EXPENDITURES</b>	<b>13,253,922.31</b>	<b>14,635,219.94</b>	<b>7,944,123.04</b>	<b>15,174,892.00</b>	<b>52.35%</b>
<b>OVERALL NET CHANGE</b>	<b>434,695.17</b>	<b>(1,167,568.99)</b>	<b>(1,223,299.18)</b>	<b>(1,579,377.00)</b>	<b>77.45%</b>
PERSONAL SERVICES	1,141,786.73	1,211,474.95	<b>734,845.12</b>	1,263,478.00	58.16%
OTHER SERVICES & CHARGES	331,027.63	334,507.13	<b>312,580.94</b>	452,310.00	69.11%
SUPPLIES	15,530.51	16,976.64	<b>6,156.11</b>	18,020.00	34.16%
CAPITAL OUTLAYS	443,913.29	36,696.53	<b>34,586.97</b>	30,000.00	115.29%
CONTINGENCY	7,334.50	122,704.77	<b>2,332.50</b>	122,000.00	1.91%
CONTRACTUAL SERVICES	333,540.28	530,758.30	<b>120,886.75</b>	139,066.00	86.93%
INTERFUND TRANSFER	933,600.98	1,569,128.48	<b>0.00</b>	1,252,200.00	0.00%
<b>GENERAL ADMINISTRATION</b>	<b>3,206,733.92</b>	<b>3,822,246.80</b>	<b>1,211,388.39</b>	<b>3,277,074.00</b>	<b>36.97%</b>
PERSONAL SERVICES	225,433.82	257,644.86	<b>163,666.86</b>	280,609.00	58.33%
OTHER SERVICES & CHARGES	94,167.87	59,771.45	<b>12,223.61</b>	81,630.00	14.97%
SUPPLIES	2,533.78	4,235.80	<b>1,578.16</b>	5,300.00	29.78%
CAPITAL OUTLAYS	0.00	0.00	<b>0.00</b>	0.00	
<b>COMMUNITY DEVELOPMENT</b>	<b>322,135.47</b>	<b>321,652.11</b>	<b>177,468.63</b>	<b>367,539.00</b>	<b>48.29%</b>
PERSONAL SERVICES	4,269,331.20	4,610,688.14	<b>2,808,143.36</b>	5,029,664.00	55.83%
OTHER SERVICES & CHARGES	369,478.24	395,557.49	<b>288,139.71</b>	390,380.00	73.81%
SUPPLIES	87,895.61	128,788.88	<b>59,174.32</b>	130,815.00	45.24%
CAPITAL OUTLAYS	40,975.52	32,176.67	<b>98,680.18</b>	32,500.00	303.63%
CONTRACTUAL SERVICES	60,000.00	60,000.00	<b>42,000.00</b>	60,000.00	70.00%

Exhibit "A"  
CITY OF BEATRICE, NEBRASKA  
GENERAL FUND BUDGETARY STATEMENTS  
FOR THE CURRENT YEAR TO DATE

AS COMPARED TO THE PRIOR TWO FISCAL YEARS

DESCRIPTION	PRIOR YEAR 2	PRIOR YEAR 1	Current as of	CURRENT YEAR	%
	ACTUAL FY2024	ACTUAL FY2025	4/30/2026	BUDGET FY2026	YTD
<b>POLICE</b>	4,827,680.57	5,227,211.18	<b>3,296,137.57</b>	5,643,359.00	58.41%
PERSONAL SERVICES	2,797,074.28	3,078,807.52	<b>1,903,669.33</b>	3,464,710.00	54.94%
OTHER SERVICES & CHARGES	376,880.97	391,032.87	<b>248,922.94</b>	405,860.00	61.33%
SUPPLIES	161,729.02	159,109.18	<b>94,719.17</b>	181,300.00	52.24%
CAPITAL OUTLAYS	717.99	1,390.92	<b>2,147.93</b>	6,500.00	33.05%
<b>FIRE</b>	3,336,402.26	3,630,340.49	<b>2,249,459.37</b>	4,058,370.00	55.43%
PERSONAL SERVICES	515,567.01	550,335.90	<b>257,387.20</b>	663,404.00	38.80%
OTHER SERVICES & CHARGES	192,935.42	196,015.42	<b>179,074.60</b>	227,465.00	78.73%
SUPPLIES	174,442.40	193,801.85	<b>83,030.42</b>	173,950.00	47.73%
CAPITAL OUTLAYS	83,011.55	29,151.24	<b>76,806.56</b>	62,400.00	123.09%
CONTRACTUAL SERVICES	69,714.75	85,203.43	<b>50,034.00</b>	85,000.00	58.86%
<b>PUBLIC PROPERTIES</b>	1,035,671.13	1,054,507.84	<b>646,332.78</b>	1,212,219.00	53.32%
PERSONAL SERVICES	336,618.00	353,513.91	<b>222,224.30</b>	408,206.00	54.44%
OTHER SERVICES & CHARGES	55,378.43	71,254.12	<b>63,380.95</b>	72,304.00	87.66%
SUPPLIES	14,399.14	10,624.82	<b>5,839.29</b>	14,000.00	41.71%
CAPITAL OUTLAYS	118,903.39	143,868.67	<b>71,891.76</b>	121,821.00	59.01%
<b>LIBRARY</b>	525,298.96	579,261.52	<b>363,336.30</b>	616,331.00	58.95%
<b>GENERAL FUND EXPENDITURES</b>	13,253,922.31	14,635,219.94	<b>7,944,123.04</b>	15,174,892.00	52.35%

Exhibit "B"

BEATRICE BOARD OF PUBLIC WORKS  
 COMBINED CASH INVESTMENT  
 APRIL 30, 2026

COMBINED CASH ACCOUNTS

9-127-21	SFB - DEBT SERVICE RESERVE	221,000.25
9-127-22	SERIES 2011/2013 BONDS - REST	( 59,789.15)
9-127-23	SRF RESV - REST	( 158,484.78)
9-127-80	SFB - BOND REVENUE RESV	4,020,333.15
9-127-81	REST - BOND REV	( 4,020,333.15)
9-131-00	SECURITY 1ST BANK - CHECKING	100,544.18
9-132-00	PINNACLE BANK - PAYROLL	1,833.04
9-132-01	PAYROLL - PINNACLE RESTRICTED	( 1,000.00)
9-133-00	CASH-BUSINESS DEBIT ACCOUNT	650.00
9-135-00	SFB - REVOLVING LOAN FUND	368,563.08
9-135-10	REST - REVOLVING LOAN FUND	( 368,563.08)
9-137-00	SECURITY FIRST BANK MM	5,435,945.17
	TOTAL COMBINED CASH	5,540,698.71
9-100-00	CASH ALLOCATED TO OTHER FUNDS	( 5,540,698.71)

TOTAL UNALLOCATED CASH .00

CASH ALLOCATION RECONCILIATION

1	ALLOCATION TO ELECTRIC FUND	5,404,506.56
2	ALLOCATION TO WATER FUND	112,130.42
3	ALLOCATION TO WPC	24,061.73
	TOTAL ALLOCATIONS TO OTHER FUNDS	5,540,698.71
	ALLOCATION FROM COMBINED CASH FUND - 1-10000	( 5,540,698.71)
	ZERO PROOF IF ALLOCATIONS BALANCE	<u><u>.00</u></u>

## Exhibit "B"

BEATRICE BOARD OF PUBLIC WORKS  
BALANCE SHEET  
APRIL 30, 2026

ELECTRIC FUND

	CURRENT YEAR	PREVIOUS YEAR
<u>ASSETS</u>		
PLANT	43,691,575.91	41,060,346.99
ACCUMULATED DEPRECIATION	( 26,563,769.14)	( 25,109,222.64)
BOOK VALUE OF PLANT	17,127,806.77	15,951,124.35
CONSTRUCTION WORK IN PROGRESS	665,034.60	530,744.15
 <u>CASH ACCOUNTS</u>		
CASH & CASH EQUIVALENTS	5,404,506.56	4,727,392.82
CUSTOMER DEPOSITS MM	182,168.50	237,004.96
CUSTOMER DEPOSITS INVESTMENTS	726,944.16	708,903.62
PAYROLL ACCOUNT	500.00	500.00
PETTY CASH	1,375.00	1,375.00
RATE STABILIZATION FUND	1,076,670.01	1,047,299.57
ELECTRIC INFRASTRUCTURE FUND	153,757.13	.00
TEMPORARY CASH INVESTMENTS	1,909,360.86	1,831,974.84
BOND DEBT & RESERVE ACCOUNT	4,039,027.66	3,916,900.11
REVOLVING LOAN FUND RESERVE	368,563.08	367,080.21
TOTAL CASH ACCOUNTS	13,862,872.96	12,838,431.13
CUSTOMER ACCOUNTS RECEIVABLE	31,052.59	72,353.45
GARBAGE ACCOUNTS RECEIVABLE	14,211.77	16,488.90
COTTONWOOD SALES RECEIVABLE	79,734.29	33,463.05
DEVELOPER CONTRIBUTION RECEIVABLE	72,250.99	134,331.19
ALLOWANCE FOR BAD DEBTS	( 21,318.05)	( 23,662.99)
BALANCE OF ACCOUNTS RECEIVABLE	175,931.59	232,973.60
BUILDING MAINTENANCE FUND	( 9,858.77)	( 13,101.57)
INTERDEPARTMENTAL ACCOUNTS RECEIVABLE	5,440.37	23,534.14
OPERATION AND MAINTENANCE INVENTORY	1,104,790.36	1,063,066.38
PREPAID EXPENSES	81,004.00	69,818.00
INTEREST RECEIVABLE	57,407.10	66,242.32
ACCRUED UTILITY REVENUES	1,244,723.18	1,212,291.04
TOTAL ASSETS	34,315,152.16	31,975,123.54

## Exhibit "B"

BEATRICE BOARD OF PUBLIC WORKS

BALANCE SHEET

APRIL 30, 2026

ELECTRIC FUND

	CURRENT YEAR	PREVIOUS YEAR
<u>LIABILITIES AND EQUITY</u>		
<u>LIABILITIES</u>		
2025 BONDS PAYABLE	3,788,340.70	3,952,431.80
2025 BOND PREMIUM	54,777.03	.00
ACCOUNTS PAYABLE	1,678,531.84	1,204,078.57
UNCLAIMED PROPERTY PAYABLE	( 3,035.25)	.00
ACCOUNTS PAYABLE-GARBAGE	20,837.80	21,663.97
CUSTOMER DEPOSITS PAYABLE	844,941.41	901,559.00
SALES TAX PAYABLE-STATE	2.01	.00
SALES TAX PAYABLE-LOCAL	.73	.03
SALES TAX PAYABLE-COUNTY	.51	( .02)
ACCRUED INTEREST PAYABLE	( 48,951.29)	.00
ACCRUED VACATION TIME	167,931.00	165,270.47
ACCRUED COMP TIME PAYABLE	30,361.02	27,650.18
ACCRUED SICK TIME PAYABLE	310,816.34	300,685.29
	6,844,553.85	6,573,339.29
<u>FUND EQUITY</u>		
NET INVEST IN CAPITAL ASSETS	13,345,660.00	16,620,637.00
RESTRICTED FOR DEBT SERVICE	59,376.00	.00
RESTRICTED FOR REVLOVING LOAN	367,707.52	366,228.52
UNRESTRICTED NET POSITION	13,654,372.17	9,231,886.78
REVENUE OVER EXPENDITURES - YTD	43,482.62	( 816,968.05)
BALANCE - CURRENT DATE	27,470,598.31	25,401,784.25
TOTAL FUND EQUITY	27,470,598.31	25,401,784.25
TOTAL LIABILITIES AND EQUITY	34,315,152.16	31,975,123.54

## Exhibit "B"

BEATRICE BOARD OF PUBLIC WORKS  
OPERATING STATEMENT  
FOR THE 7 MONTHS ENDING APRIL 30, 2026

### ELECTRIC FUND

	PERIOD ACTUAL	YTD ACTUAL	BUDGET	UNEARNED	PCNT	PREV YTD AMT
<b>OPERATING REVENUE</b>						
RESIDENTIAL SALES	238,091.29	1,955,625.04	( 3,868,500.00)	( 5,824,125.04)	50.6	1,909,054.99
RESIDENTIAL HEATING SALES	189,850.60	1,906,393.60	( 3,072,000.00)	( 4,978,393.60)	62.1	1,854,295.13
GENERAL SERVICE SALES	123,651.75	925,454.04	( 1,600,000.00)	( 2,525,454.04)	57.8	874,351.66
GENERAL SERVICE HEATING SALES	52,158.03	553,694.93	( 910,500.00)	( 1,464,194.93)	60.8	524,867.35
GENERAL SERVICE DEMAND SALES	468,016.25	3,435,699.87	( 5,900,000.00)	( 9,335,699.87)	58.2	3,403,716.24
LARGE POWER CONTRACT	126,940.27	1,180,243.36	( 1,750,000.00)	( 2,930,243.36)	67.4	843,579.02
PUBLIC STREET & HIGHWAY LIGHTING	6,848.30	51,931.22	( 88,000.00)	( 139,931.22)	59.0	49,222.87
INFRASTRUCTURE FEE	22,627.00	158,666.60	( 840,000.00)	( 998,666.60)	18.9	.00
INTERDEPARTMENTAL SALES	3,751.17	24,874.43	( 50,000.00)	( 74,874.43)	49.8	31,107.21
SECURITY LIGHTING SALES	8,558.81	59,983.83	( 102,000.00)	( 161,983.83)	58.8	61,046.62
ENGINEERING DEPARTMENT INCOME	14,522.00	101,714.00	( 174,000.00)	( 275,714.00)	58.5	93,256.00
MARKET SALES	84,017.45	563,566.70	( 650,000.00)	( 1,213,566.70)	86.7	297,146.76
RENEWABLE ENERGY CREDITS	.00	63,724.10	( 100,000.00)	( 163,724.10)	63.7	.00
<b>TOTAL OPERATING REVENUE</b>	<b>1,339,032.92</b>	<b>10,981,571.72</b>	<b>( 19,105,000.00)</b>	<b>( 30,086,571.72)</b>	<b>57.5</b>	<b>9,941,643.85</b>
<b>OPERATING EXPENSE</b>						
PURCHASED POWER	( 814,224.35)	( 6,561,750.87)	( 10,200,000.00)	( 3,638,249.13)	( 64.3)	( 6,278,594.61)
PURCHASED POWER - WAPA	( 38,307.88)	( 298,329.38)	( 525,000.00)	( 226,670.62)	( 56.8)	( 272,724.63)
PURCHASED POWER - COTTONWOOD	( 113,830.97)	( 717,233.43)	( 1,300,000.00)	( 582,766.57)	( 55.2)	( 805,693.13)
OPERATION & MAINTENANCE	( 195,656.50)	( 774,573.83)	( 1,506,638.00)	( 732,064.17)	( 51.4)	( 852,226.89)
ACCOUNTING & COLLECTING	( 12,977.68)	( 108,972.56)	( 164,121.00)	( 55,148.44)	( 66.4)	( 154,086.59)
METER READING	( 2,578.85)	( 20,077.01)	( 35,378.00)	( 15,300.99)	( 56.8)	( 21,349.24)
ENGINEERING DEPARTMENT	( 35,744.00)	( 257,863.93)	( 455,420.00)	( 197,556.07)	( 56.6)	( 268,375.75)
INFOMATIONAL TECH - COMPUTERS	.00	( 8,597.85)	.00	8,597.85	.0	( 188,955.54)
ADMINISTRATIVE	( 67,749.53)	( 471,445.08)	( 807,385.00)	( 335,939.92)	( 58.4)	( 122,880.62)
GENERAL	( 80,566.59)	( 702,603.57)	( 988,076.00)	( 285,472.43)	( 71.1)	( 606,376.22)
VEHICLE & EQUIPMENT EXPENSES	( 8,971.65)	( 142,371.76)	( 171,500.00)	( 29,128.24)	( 83.0)	( 147,114.52)
DEPRECIATION	( 125,821.04)	( 879,738.98)	( 1,465,000.00)	( 585,261.02)	( 60.1)	( 856,550.96)
<b>TOTAL OPERATING EXPENSES</b>	<b>( 1,496,429.04)</b>	<b>( 10,943,558.25)</b>	<b>( 17,618,518.00)</b>	<b>( 6,674,959.75)</b>	<b>( 62.1)</b>	<b>( 10,574,928.70)</b>
<b>NET OPERATING REVENUE</b>	<b>( 157,396.12)</b>	<b>38,013.47</b>	<b>( 36,723,518.00)</b>	<b>( 36,761,531.47)</b>	<b>.1</b>	<b>( 633,284.85)</b>
<b>OTHER INCOME (EXPENSES)</b>						
MISCELLANEOUS INCOME	20,944.85	224,708.91	( 1,058,000.00)	( 1,282,708.91)	21.2	253,320.59
INTEREST INCOME	19,771.82	143,844.54	( 101,000.00)	( 244,844.54)	142.4	166,508.94
RESTRICTED INTEREST INCOME	10,378.35	75,752.24	.00	( 75,752.24)	.0	1,230.36
AMORTIZATION EXPENSES-BONDS	.00	.00	.00	.00	.0	( 69,924.84)
INTEREST EXPENSES	.00	.00	( 197,930.00)	( 197,930.00)	.0	.00
MUNICIPAL EXPENSE	( 58,660.07)	( 438,836.54)	( 742,185.00)	( 303,348.46)	( 59.1)	( 534,818.25)
<b>NET NONOPERATING INCOME (EXPENSE)</b>	<b>( 17,948.00)</b>	<b>( 69,557.10)</b>	<b>( 2,099,115.00)</b>	<b>( 2,029,557.90)</b>	<b>( 3.3)</b>	<b>( 115,115.44)</b>
<b>TOTAL NET INCOME OR (LOSS)</b>	<b>( 164,961.17)</b>	<b>43,482.62</b>	<b>( 38,822,633.00)</b>	<b>( 38,866,115.62)</b>	<b>.1</b>	<b>( 816,968.05)</b>

Exhibit "B"

BEATRICE BOARD OF PUBLIC WORKS

BALANCE SHEET

APRIL 30, 2026

WATER FUND

	<u>CURRENT YEAR</u>	<u>PREVIOUS YEAR</u>
<u>ASSETS</u>		
PLANT	33,881,191.16	33,338,797.76
ACCUMULATED DEPRECIATION	( 17,389,304.17)	( 16,451,167.29)
BOOK VALUE OF PLANT	16,491,886.99	16,887,630.47
CONSTRUCTION WORK IN PROGRESS	948,200.76	205,242.73
<u>CASH ACCOUNTS</u>		
CASH & CASH EQUIVALENTS	112,130.42	489,906.23
PAYROLL ACCOUNT	300.00	300.00
PETTY CASH	300.00	300.00
WATER INFRASTRUCTURE FEE	1,271,020.87	1,025,275.13
TEMPORARY CASH INVESTMENTS CD'S	580,493.35	557,723.98
BOND DEBT & RESERVE ACCOUNT	17,973.51	699,848.18
SRF RESERVE ACCOUNT	158,484.78	158,446.07
TOTAL CASH ACCOUNTS	2,140,702.93	2,931,799.59
CUSTOMER ACCOUNTS RECEIVABLE	159,050.04	57,679.30
ALLOWANCE FOR BAD DEBTS	( 13,146.68)	( 13,764.54)
BALANCE OF ACCOUNTS RECEIVABLE	145,903.36	43,914.76
INTERDEPARTMENTAL ACCOUNTS RECEIVABLE	.00	557.82
OPERATION AND MAINTENANCE INVENTORY	773,409.61	772,252.45
PREPAID EXPENSES	68,528.99	47,681.99
INTEREST RECEIVABLE	13,697.30	16,115.81
ACCRUED UTILITY REVENUES	230,861.13	228,379.40
TOTAL ASSETS	<u>20,813,191.07</u>	<u>21,133,575.02</u>

## Exhibit "B"

BEATRICE BOARD OF PUBLIC WORKS  
BALANCE SHEET  
APRIL 30, 2026

WATER FUND

	CURRENT YEAR	PREVIOUS YEAR
<u>LIABILITIES AND EQUITY</u>		
<u>LIABILITIES</u>		
SRF BONDS PAYABLE	8,104,292.62	8,386,927.09
2025 BONDS PAYABLE	548,112.99	638,491.08
2025 BOND PREMIUM	8,449.56	.00
ACCOUNTS PAYABLE	130,970.20	50,336.83
SALES TAX PAYABLE-STATE	33.51	( 25.73)
SALES TAX PAYABLE-LOCAL	12.19	( 9.36)
ACCRUED INTEREST PAYABLE	( 37,866.08)	( 1,043.30)
ACCRUED FICA TAXES PAYABLE	25.00	25.00
ACCRUED VACATION TIME	53,128.47	44,849.39
ACCRUED COMP TIME PAYABLE	19,860.52	21,216.26
ACCRUED SICK TIME	34,277.34	31,085.14
TOTAL LIABILITIES	8,861,296.32	9,171,852.40
 <u>FUND EQUITY</u>		
NET INVEST IN CAPITAL ASSETS	8,155,441.00	8,202,869.00
RESTRICTED FOR DEBT SERVICE	73,176.00	.00
UNRESTRICTED NET POSITION	3,866,103.41	3,827,847.20
REVENUE OVER EXPENDITURES - YTD	( 142,825.66)	( 68,993.58)
BALANCE - CURRENT DATE	11,951,894.75	11,961,722.62
TOTAL FUND EQUITY	11,951,894.75	11,961,722.62
TOTAL LIABILITIES AND EQUITY	20,813,191.07	21,133,575.02

**Exhibit "B"**

BEATRICE BOARD OF PUBLIC WORKS  
OPERATING STATEMENT  
FOR THE 7 MONTHS ENDING APRIL 30, 2026

WATER FUND

	PERIOD ACTUAL	YTD ACTUAL	BUDGET	UNEARNED	PCNT	PREV YTD AMT
<b>OPERATING REVENUE</b>						
RESIDENTIAL SALES	124,726.00	835,703.45	( 1,658,500.00)	( 2,494,203.45)	50.4	871,050.64
COMMERCIAL SALES	51,364.49	314,621.77	( 680,000.00)	( 994,621.77)	46.3	338,192.80
CONTRACT SALES	32,528.34	226,455.18	( 400,000.00)	( 626,455.18)	56.6	216,470.43
INFRASTRUCTURE FEE	22,895.00	160,044.00	( 276,000.00)	( 436,044.00)	58.0	82,078.00
<b>TOTAL OPERATING REVENUE</b>	<b>231,513.83</b>	<b>1,536,824.40</b>	<b>( 3,014,500.00)</b>	<b>( 4,551,324.40)</b>	<b>51.0</b>	<b>1,507,791.87</b>
<b>OPERATING EXPENSE</b>						
OPERATION & MAINTENANCE	( 96,774.54)	( 723,448.43)	( 1,296,512.00)	( 573,063.57)	( 55.8)	( 647,239.35)
ACCOUNTING & COLLECTING	( 9,022.83)	( 79,662.44)	( 112,152.00)	( 32,489.56)	( 71.0)	( 93,128.02)
METER READING	( 1,550.68)	( 12,781.36)	( 21,726.00)	( 8,944.64)	( 58.8)	( 10,026.91)
ENGINEERING DEPARTMENT	( 3,903.00)	( 27,321.00)	( 46,837.00)	( 19,516.00)	( 58.3)	( 23,471.00)
ADMINISTRATIVE	( 29,479.90)	( 207,199.80)	( 353,670.00)	( 146,470.20)	( 58.6)	( 72,343.10)
GENERAL	( 53,776.72)	( 368,757.56)	( 592,960.00)	( 224,202.44)	( 62.2)	( 311,300.75)
VEHICLE & EQUIPMENT EXPENSES	( 4,234.94)	( 25,674.48)	( 91,000.00)	( 65,325.52)	( 28.2)	( 28,913.84)
DEPRECIATION	( 85,576.99)	( 600,716.34)	( 990,000.00)	( 389,283.66)	( 60.7)	( 578,207.18)
<b>TOTAL OPERATING EXPENSES</b>	<b>( 284,319.60)</b>	<b>( 2,045,561.41)</b>	<b>( 3,504,857.00)</b>	<b>( 1,459,295.59)</b>	<b>( 58.4)</b>	<b>( 1,764,630.15)</b>
<b>NET OPERATING INCOME (LOSS)</b>	<b>( 52,805.77)</b>	<b>( 508,737.01)</b>	<b>( 6,519,357.00)</b>	<b>( 6,010,619.99)</b>	<b>( 7.8)</b>	<b>( 256,838.28)</b>
<b>OTHER INCOME (EXPENSES)</b>						
MISCELLANEOUS INCOME	32,372.76	201,110.30	( 287,500.00)	( 488,610.30)	70.0	152,812.27
INTEREST INCOME	7,109.87	53,334.54	( 100,000.00)	( 153,334.54)	53.3	58,924.91
RESTRICTED INTEREST INCOME	281.32	4,239.64	( 3,000.00)	( 7,239.64)	141.3	6,500.91
GRANT INCOME	.00	133,134.29	.00	( 133,134.29)	.0	.00
OTHER INCOME	39.50	5,310.84	( 2,000.00)	( 7,310.84)	265.5	39,098.85
AMORTIZATION EXPENSES- BONDS	.00	.00	.00	.00	.0	( 11,295.56)
INTEREST EXPENSES	.00	.00	( 441,424.00)	( 441,424.00)	.0	.00
MUNICIPAL EXPENSE	( 7,439.00)	( 31,218.26)	( 70,500.00)	( 39,281.74)	( 44.3)	( 58,196.68)
<b>NET NONOPERATING INCOME (EXPENSE)</b>	<b>32,364.45</b>	<b>365,911.35</b>	<b>( 904,424.00)</b>	<b>( 1,270,335.35)</b>	<b>40.5</b>	<b>187,844.70</b>
<b>TOTAL NET INCOME (LOSS)</b>	<b>( 20,441.32)</b>	<b>( 142,825.66)</b>	<b>( 7,423,781.00)</b>	<b>( 7,280,955.34)</b>	<b>( 1.9)</b>	<b>( 68,993.58)</b>

## Exhibit "B"

BEATRICE BOARD OF PUBLIC WORKS  
BALANCE SHEET  
APRIL 30, 2026

WPC

	CURRENT YEAR	PREVIOUS YEAR
<u>ASSETS</u>		
PLANT	28,990,134.90	27,944,195.99
ACCUMULATED DEPRECIATION	( 18,768,066.28)	( 18,434,750.62)
BOOK VALUE OF PLANT	10,222,068.62	9,509,445.37
CONSTRUCTION WORK IN PROGRESS	1,269,053.65	223,346.20
<u>CASH ACCOUNTS</u>		
CASH & CASH EQUIVALENTS	24,061.73	838,331.00
PAYROLL ACCOUNT	200.00	200.00
PETTY CASH	175.00	175.00
SEWER INFRASTRUCTURE FEE	2,902,555.75	2,422,644.87
BOND DEBT & RESERVE ACCOUNT	23,121.10	587,449.61
TOTAL CASH ACCOUNTS	2,950,113.58	3,848,800.48
CUSTOMER ACCOUNTS RECEIVABLE	19,125.12	20,214.32
ALLOWANCE FOR BAD DEBTS	( 7,170.21)	( 7,536.67)
BALANCE OF ACCOUNTS RECEIVABLE	11,954.91	12,677.65
INTERDEPARTMENTAL ACCOUNTS RECEIVABLE	1,980.26	1,115.48
PREPAID EXPENSES	42,684.00	32,103.00
ACCRUED UTILITY REVENUES	208,930.88	197,251.53
TOTAL ASSETS	14,706,785.90	13,824,739.71

## Exhibit "B"

BEATRICE BOARD OF PUBLIC WORKS  
BALANCE SHEET  
APRIL 30, 2026

WPC

	CURRENT YEAR	PREVIOUS YEAR
<u>LIABILITIES AND EQUITY</u>		
<u>LIABILITIES</u>		
2025 BONDS PAYABLE	408,546.31	475,919.32
2025 BOND PREMIUM	6,298.11	.00
ACCOUNTS PAYABLE	258,796.73	43,004.59
ACCRUED INTEREST PAYABLE	( 27,471.29)	.00
ACCRUED VACATION TIME	28,219.47	33,033.04
ACCRUED COMP TIME PAYABLE	13,039.15	8,710.18
ACCRUED SICK TIME	37,831.06	35,604.91
	725,259.54	596,272.04
<u>FUND EQUITY</u>		
NET INVEST IN CAPITAL ASSETS	9,649,202.00	9,343,905.00
RESTRICTED FOR DEBT SERVICE	102,753.00	.00
UNRESTRICTED NET POSITION	4,172,663.06	3,585,330.82
REVENUE OVER EXPENDITURES - YTD	56,908.30	299,231.85
	13,981,526.36	13,228,467.67
BALANCE - CURRENT DATE		
	13,981,526.36	13,228,467.67
TOTAL FUND EQUITY		
	14,706,785.90	13,824,739.71
TOTAL LIABILITIES AND EQUITY		

## Exhibit "B"

BEATRICE BOARD OF PUBLIC WORKS  
OPERATING STATEMENT  
FOR THE 7 MONTHS ENDING APRIL 30, 2026

WPC

	PERIOD ACTUAL	YTD ACTUAL	BUDGET	UNEARNED	PCNT	PREV YEAR YTD
<u>OPERATING REVENUE</u>						
RESIDENTIAL SALES	118,523.96	826,596.31	( 1,396,000.00)	( 2,222,596.31)	59.2	819,803.90
COMMERCIAL SALES	51,714.60	333,307.19	( 680,000.00)	( 1,013,307.19)	49.0	344,213.51
INFRASTRUCTURE FEE	39,463.00	276,144.00	( 470,000.00)	( 746,144.00)	58.8	198,074.00
<b>TOTAL OPERATING REVENUE</b>	<b>209,701.56</b>	<b>1,436,047.50</b>	<b>( 2,546,000.00)</b>	<b>( 3,982,047.50)</b>	<b>56.4</b>	<b>1,362,091.41</b>
<u>OPERATING EXPENSE</u>						
OPERATION & MAINTENANCE	( 71,622.62)	( 595,828.99)	( 875,812.00)	( 279,983.01)	( 68.0)	( 479,312.56)
ACCOUNTING & COLLECTING	( 6,162.94)	( 55,054.99)	( 93,519.00)	( 38,464.01)	( 58.9)	( 54,553.17)
METER READING	( 997.79)	( 8,007.91)	( 13,151.00)	( 5,143.09)	( 60.9)	( 7,659.86)
ENGINEERING DEPARTMENT	( 3,903.00)	( 27,321.00)	( 46,837.00)	( 19,516.00)	( 58.3)	( 23,471.00)
ADMINISTRATIVE	( 20,009.60)	( 140,036.69)	( 240,211.00)	( 100,174.31)	( 58.3)	( 48,011.40)
GENERAL	( 32,108.79)	( 224,252.48)	( 366,575.00)	( 142,322.52)	( 61.2)	( 154,645.91)
VEHICLE & EQUIPMENT EXPENSES	( 4,180.86)	( 24,155.07)	( 65,000.00)	( 40,844.93)	( 37.2)	( 26,643.29)
DEPRECIATION	( 59,195.82)	( 415,416.12)	( 640,000.00)	( 224,583.88)	( 64.9)	( 368,011.65)
<b>TOTAL OPERATING EXPENSES</b>	<b>( 198,181.42)</b>	<b>( 1,490,073.25)</b>	<b>( 2,341,105.00)</b>	<b>( 851,031.75)</b>	<b>( 63.7)</b>	<b>( 1,162,308.84)</b>
<b>NET OPERATING REVENUE</b>	<b>11,520.14</b>	<b>( 54,025.75)</b>	<b>( 4,887,105.00)</b>	<b>( 4,833,079.25)</b>	<b>( 1.1)</b>	<b>199,782.57</b>
<u>OTHER INCOME (EXPENSES)</u>						
MISCELLANEOUS INCOME	7,450.94	45,013.57	( 68,000.00)	( 113,013.57)	66.2	40,436.34
INTEREST INCOME	9,525.83	69,498.10	( 100,000.00)	( 169,498.10)	69.5	77,634.61
RESTRICTED INTEREST INCOME	146.05	2,201.36	( 4,000.00)	( 6,201.36)	55.0	2,327.33
GRANT INCOME	.00	.00	( 2,000,000.00)	( 2,000,000.00)	.0	.00
OTHER INCOME	910.00	2,625.00	( 1,000.00)	( 3,625.00)	262.5	2,765.00
AMORTIZATION EXPENSES- BONDS	.00	.00	.00	.00	.0	( 8,426.83)
INTEREST EXPENSES	.00	.00	( 111,055.00)	( 111,055.00)	.0	.00
MUNICIPAL EXPENSE	( 477.13)	( 8,403.98)	( 30,500.00)	( 22,096.02)	( 27.6)	( 15,287.17)
<b>NET NONOPERATING INCOME (EXPENSE)</b>	<b>17,555.69</b>	<b>110,934.05</b>	<b>( 2,314,555.00)</b>	<b>( 2,425,489.05)</b>	<b>4.8</b>	<b>99,449.28</b>
<b>TOTAL NET INCOME (LOSS)</b>	<b>29,075.83</b>	<b>56,908.30</b>	<b>( 7,201,660.00)</b>	<b>( 7,258,568.30)</b>	<b>.8</b>	<b>299,231.85</b>

**Exhibit "B"**  
CITY OF BEATRICE  
COMBINED CASH INVESTMENT  
APRIL 30, 2026

COMBINED CASH ACCOUNTS

\_\_\_\_\_  
\_\_\_\_\_  
\_\_\_\_\_

CASH ALLOCATION RECONCILIATION

3 ALLOCATION TO STREET FUND	3,712,877.45
TOTAL ALLOCATIONS TO OTHER FUNDS	3,712,877.45
ZERO PROOF IF ALLOCATIONS BALANCE	3,712,877.45

Exhibit "B"

CITY OF BEATRICE  
BALANCE SHEET  
APRIL 30, 2026

STREET FUND

ASSETS

03-00-100-00	CASH - COMBINED CASH FUND	3,712,877.45	
03-00-101-03	CASH-HIGHWAY ALLOC DEBT RESV	187,120.00	
03-00-103-01	CASH-BOND FUNDS	315,935.71	
03-00-120-00	ACCOUNTS RECEIVABLE	74,009.50	
03-00-129-00	DUE FROM OTHER GOVERNMENTS	298,712.68	
03-00-130-00	DUE FROM SPEC ASSESS FUND	49,626.00	
		<u>                    </u>	
	TOTAL ASSETS		<u>4,638,281.34</u>

LIABILITIES AND EQUITY

LIABILITIES

03-00-201-00	ACCOUNTS PAYABLE	57,404.87	
03-00-215-00	ACCRUED INTEREST PAYABLE	34,585.00	
03-00-231-00	BONDS PAYABLE-L.T.	2,600,000.00	
		<u>                    </u>	
	TOTAL LIABILITIES		2,691,989.87

FUND EQUITY

03-00-250-01	DESIGNATED FOR STREETS	2,312,581.07	
	UNAPPROPRIATED FUND BALANCE:		
	REVENUE OVER (UNDER) EXPENDITURES - YTD	<u>( 366,289.60)</u>	
	BALANCE - CURRENT DATE	<u>( 366,289.60)</u>	
	TOTAL FUND EQUITY		<u>1,946,291.47</u>
	TOTAL LIABILITIES AND EQUITY		<u>4,638,281.34</u>

**Exhibit "B"**

CITY OF BEATRICE  
REVENUES WITH COMPARISON TO BUDGET  
FOR THE 7 MONTHS ENDING APRIL 30, 2026

STREET FUND

	<u>PERIOD ACTUAL</u>	<u>YTD ACTUAL</u>	<u>BUDGET</u>	<u>UNEARNED</u>	<u>PCNT</u>
<u>SALES TAX</u>					
03-20-313-01 SALES TAX (30%OF1%)LESS MV	20,000.00	156,277.39	250,000.00	93,722.61	62.5
03-20-313-02 SALES TAX ON MOTOR VEHICLES	55,000.00	364,447.75	630,000.00	265,552.25	57.9
<b>TOTAL SALES TAX</b>	<b>75,000.00</b>	<b>520,725.14</b>	<b>880,000.00</b>	<b>359,274.86</b>	<b>59.2</b>
<u>STATE AGENCY AID</u>					
03-20-332-01 HIGHWAY ALLOCATION, INCEN PMT	146,025.13	1,083,331.26	1,845,514.00	762,182.74	58.7
03-20-332-02 STATE MAINTENANCE CONTRACT	.00	.00	65,898.00	65,898.00	.0
03-20-332-05 STATE PROJECT FUNDING	.00	296,134.83	280,000.00	( 16,134.83)	105.8
03-20-332-06 MOTOR VEHICLE FEE PMT	.00	34,470.22	125,000.00	90,529.78	27.6
<b>TOTAL STATE AGENCY AIDL</b>	<b>146,025.13</b>	<b>1,413,936.31</b>	<b>2,316,412.00</b>	<b>902,475.69</b>	<b>61.0</b>
<u>FEDERAL AGENCY AID</u>					
03-20-334-01 FEDERAL GRANTS	.00	170,644.67	500,000.00	329,355.33	34.1
<b>TOTAL FEDERAL AGENCY AID</b>	<b>.00</b>	<b>170,644.67</b>	<b>500,000.00</b>	<b>329,355.33</b>	<b>34.1</b>
<u>STREET FEES</u>					
03-20-349-00 STREET CHARGES FOR SERVICES	.00	5,131.17	8,000.00	2,868.83	64.1
03-20-349-02 STREET SALES	.00	210.00	500.00	290.00	42.0
03-20-349-03 STREET REIMBURSEMENTS	1,594.00	11,623.50	24,000.00	12,376.50	48.4
<b>TOTAL STREET FEES</b>	<b>1,594.00</b>	<b>16,964.67</b>	<b>32,500.00</b>	<b>15,535.33</b>	<b>52.2</b>
<u>INTEREST EARNINGS</u>					
03-20-361-01 INTEREST EARNING - HWY ALL BND	1,168.31	24,366.52	.00	( 24,366.52)	.0
<b>TOTAL INTEREST EARNINGS</b>	<b>1,168.31</b>	<b>24,366.52</b>	<b>.00</b>	<b>( 24,366.52)</b>	<b>.0</b>
<u>DONATIONS</u>					
03-20-367-01 PRIVATE FUNDING	.00	82,289.92	.00	( 82,289.92)	.0
<b>TOTAL DONATIONS</b>	<b>.00</b>	<b>82,289.92</b>	<b>.00</b>	<b>( 82,289.92)</b>	<b>.0</b>

**Exhibit "B"**

CITY OF BEATRICE  
 REVENUES WITH COMPARISON TO BUDGET  
 FOR THE 7 MONTHS ENDING APRIL 30, 2026

STREET FUND

	<u>PERIOD ACTUAL</u>	<u>YTD ACTUAL</u>	<u>BUDGET</u>	<u>UNEARNED</u>	<u>PCNT</u>
<u>INTERFUND TRANSFERS</u>					
03-20-371-01 INTERFUND TRANSFER	( 15,430.00)	2,230.33	.00	( 2,230.33)	.0
TOTAL INTERFUND TRANSFERS	( 15,430.00)	2,230.33	.00	( 2,230.33)	.0
TOTAL FUND REVENUE	208,357.44	2,231,157.56	3,728,912.00	1,497,754.44	59.8

# Exhibit "B"

## CITY OF BEATRICE EXPENDITURES WITH COMPARISON TO BUDGET FOR THE 7 MONTHS ENDING APRIL 30, 2026

### STREET FUND

	PERIOD ACTUAL	YTD ACTUAL	BUDGET	UNEXPENDED	PCNT
<u>STREET FUND</u>					
03-20-411-01 SALARIES (MAINT)	43,802.34	310,925.96	549,237.00	238,311.04	56.6
03-20-411-02 SALARIES (OVERTIME)	.00	5,446.22	12,765.00	7,318.78	42.7
03-20-411-03 SALARIES (PART-TIME)	1,192.50	1,192.50	17,500.00	16,307.50	6.8
03-20-411-06 SALARIES(BPW SNOW/OTHER MAINT)	1,291.17	1,291.17	2,000.00	708.83	64.6
03-20-411-07 SALARIES (LEGAL/CITY)	827.00	5,789.00	11,677.00	5,888.00	49.6
03-20-411-10 SALARIES (BPW ENGINEERING)	5,612.00	39,284.00	67,349.00	28,065.00	58.3
03-20-411-20 SALARIES (CITY-MGR SERVICES)	1,776.00	12,432.00	21,306.00	8,874.00	58.4
03-20-412-01 SOCIAL SECURITY	3,262.12	23,277.90	45,507.00	22,229.10	51.2
03-20-413-01 RETIREMENT	2,663.25	17,114.48	32,817.00	15,702.52	52.2
03-20-414-01 HEALTH & LIFE INSURANCE	25,200.00	176,525.00	293,664.00	117,139.00	60.1
03-20-415-01 WORKERS' COMPENSATION	.00	42,234.00	54,218.00	11,984.00	77.9
03-20-421-01 INSURANCE	.00	33,688.00	34,287.00	599.00	98.3
03-20-422-60 INFO. TECH. SERVICES	7,192.00	50,344.00	86,303.00	35,959.00	58.3
03-20-424-01 BUILDING MAINT./REPAIRS	75.27	994.68	2,500.00	1,505.32	39.8
03-20-424-02 EQUIP OTHER & RADIO REPAIR	269.18	326.18	1,000.00	673.82	32.6
03-20-424-03 ROAD EQUIP REP/MAINT (LABOR)	3,797.00	49,146.91	45,000.00	( 4,146.91)	109.2
03-20-425-01 BUILDING RENTALS (SHOP-BPW)	250.00	2,100.00	3,000.00	900.00	70.0
03-20-425-04 EQUIPMENT RENTALS	1,659.37	3,040.62	8,000.00	4,959.38	38.0
03-20-425-05 SOFTWARE MAINTENANCE	.00	.00	5,800.00	5,800.00	.0
03-20-425-06 WEED SPRAYING/TREE TRIMMING	.00	465.00	4,750.00	4,285.00	9.8
03-20-426-01 TRAINING/TRAVEL EXPENSES	480.00	1,050.91	4,000.00	2,949.09	26.3
03-20-427-01 TELEPHONE	50.00	350.00	.00	( 350.00)	.0
03-20-429-04 BAD DEBT EXPENSE	.00	.00	200.00	200.00	.0
03-20-429-05 OTHER SERV & CHGS (MS4)	4,678.75	22,910.00	35,000.00	12,090.00	65.5
03-20-429-06 OTHER SERV & CHGS (SPC FEES)	2,517.07	54,452.41	45,000.00	( 9,452.41)	121.0
03-20-432-01 GAS & OIL	4,184.95	26,161.78	58,000.00	31,838.22	45.1
03-20-432-02 UNIFORMS	428.39	1,192.83	3,000.00	1,807.17	39.8
03-20-432-04 CHEMICALS	7,593.20	7,643.18	10,000.00	2,356.82	76.4
03-20-432-09 TRAFFIC CONTROL	20,307.15	31,575.98	25,000.00	( 6,575.98)	126.3
03-20-432-13 SHOP/JANITORIAL/OSHA SUPPLIES	879.11	5,148.05	8,500.00	3,351.95	60.6
03-20-433-02 ROAD EQ MNT TIRES/BROOMS/BLADE	.00	16,828.49	30,000.00	13,171.51	56.1
03-20-433-03 ROAD EQUIP REPAIRS (PARTS)	5,763.45	52,623.23	55,000.00	2,376.77	95.7
03-20-433-05 ROAD IMP MATERIALS (IN-HOUSE)	36,621.31	53,874.43	125,000.00	71,125.57	43.1
03-20-433-06 ROAD MATERIALS ICE CONTROL	.00	17,172.55	75,000.00	57,827.45	22.9
03-20-434-01 SMALL TOOLS & MINOR EQ	98.96	5,278.43	3,500.00	( 1,778.43)	150.8
03-20-443-01 STREET IMP/ARMORCOAT/REJUVINAT	.00	14,345.83	65,000.00	50,654.17	22.1
03-20-443-06 STREET IMP/MISC CONC REPAIR	1,019.98	38,620.77	80,000.00	41,379.23	48.3
03-20-443-12 STREET IMP/HIGHWAY PROJECTS	.00	.00	500,000.00	500,000.00	.0
03-20-443-13 STREET IMP/QCT ELLA STREET	.00	4,264.00	.00	( 4,264.00)	.0
03-20-443-15 STREET IMP - DT BEAUTIFICATION	60,027.53	60,231.53	.00	( 60,231.53)	.0
03-20-443-20 STREET IMP/RECONSTRUCTION	.00	4,577.50	445,000.00	440,422.50	1.0
03-20-443-21 STREET IMP/NEW STREETS	111,659.30	1,342,059.71	1,496,631.00	154,571.29	89.7
03-20-443-22 STREET IMP-33RD & LINCOLN	.00	9,590.91	.00	( 9,590.91)	.0
03-20-443-24 STREET IMP/STORM SEWER RECONC	.00	.00	50,000.00	50,000.00	.0
03-20-444-01 MACHINERY & EQUIPMENT	.00	.00	514,000.00	514,000.00	.0
03-20-451-01 CONTINGENCY	.00	.00	100,000.00	100,000.00	.0
03-20-472-01 INTEREST-HWY ALLOC SERIES 25	.00	51,877.02	109,165.00	57,287.98	47.5
<b>TOTAL STREET FUND</b>	<b>355,178.35</b>	<b>2,597,447.16</b>	<b>5,135,676.00</b>	<b>2,538,228.84</b>	<b>50.6</b>

Exhibit "B"

CITY OF BEATRICE  
EXPENDITURES WITH COMPARISON TO BUDGET  
FOR THE 7 MONTHS ENDING APRIL 30, 2026

STREET FUND

	<u>PERIOD ACTUAL</u>	<u>YTD ACTUAL</u>	<u>BUDGET</u>	<u>UNEXPENDED</u>	<u>PCNT</u>
TOTAL FUND EXPENDITURES	<u>355,178.35</u>	<u>2,597,447.16</u>	<u>5,135,676.00</u>	<u>2,538,228.84</u>	<u>50.6</u>
NET REVENUE OVER(UNDER)EXPENDITURE	<u>( 146,820.91)</u>	<u>( 366,289.60)</u>	<u>( 1,406,764.00)</u>	<u>( 1,040,474.40)</u>	<u>( 26.0)</u>

Exhibit "C"  
**CODE VIOLATIONS SUMMARY**

	Year-to-Date
Referred to BPD	1
Referred to Other City Department	1
<b>Total Closed Cases</b>	<b>241</b>
<b>Total Cases Received</b>	<b>400</b>

Current Pending Cases	2
Current Open Cases	155
Cases Closed in May	71

**REFERRED TO BPD: 1**

Case #	Date Opened	Violation	Reason for Violation	Location
20260400	5/29/2026	JMV	Silver Buick on the street with all tires removed.	1022 N 8th Street

**REFERRED TO OTHER CITY DEPT: 1**

Case #	Date Opened	Violation	Reason for Violation	Location
20260400	5/29/2026	JMV	Silver Buick on the street with all tires removed.	1022 N 8th Street

**PENDING CASES: 2**

Case #	Date Opened	Violation	Reason for Violation	Location
20260197	4/16/2026	Code	Large pile of trash/trashbags/junk in back yard along the house.	1022 North 8th Street
20260032	1/27/2026	Dog Bite	Dog Bite. Person(s) potentially living in the shop or camper area.	411 Court Street

**OPEN CASES: 155**

Case #	Date Opened	Violation	Reason for Violation	Location
20260399	5/29/2026	Weeds	Grass overgrown on property	1205 Jackson Street
20260398	5/29/2026	JMV		503 Grace Street

## Exhibit "C"

20260397	5/29/2026	Zoning	Commercial shed being used as residence. Creation of Single family residence in CBD not allowed. No utilities, water or sewer.	816 Market Street
20260396	5/28/2026	Weeds	Overgrown grass and weeds on corner of 4th and Marlborough Streets and along 4th Street. Sight triangle issue for motorists. Needs to be 30" or lower	400 Marlborough Avenue
20260395	5/27/2026	Code	Mattresses leaning up against garage.	428 Wiebe Street
20260394	5/27/2026	Code	Trash/clothes/junk sitting on front porch	1206 N 8th Street
20260393	5/27/2026	Code	Appliances on front porch, Refrigerator and deep freeze	417 N 8th Street
20260392	5/27/2026	Code	Mattress sitting in front yard.	902 Market Street
20260391	5/27/2026	Weeds	Overgrown grass and weeds throughout property. (complaint received)	616 N 4th Street
20260390	5/27/2026	Zoning	Abandonment of Non-Conforming Use	501 S 5TH
20260389	5/26/2026	JMV		233 S Lasalle Street
20260388	5/26/2026	Weeds	Overgrown weeds and grass at the back property line.	1406 Lincoln Street
20260387	5/26/2026	Weeds	Over grown weeds and grass along back of the property. Little strip at the back property line that isn't being mowed.	1400 Lincoln Street
20260386	5/21/2026	Code	recliner and end table set out next to dumpster	729 - 745 W Mary Street
20260385	5/21/2026	Code	Small entertainment center/shelf left out at the end of the driveway	121 S Lasalle Street
20260384	5/21/2026	Code	Broken appliances, car parts, broken green recliner along garage and fence.	1305 Court Street
20260383	5/21/2026	JMV		1305 Court Street
20260379	5/19/2026	Weeds	Overgrown Grass and Weeds on Property	123 S Sumner
20260378	5/19/2026	Weeds	Overgrown Grass and Weeds on Property	923 N 6th Street
20260377	5/19/2026	Weeds	Overgrown Grass and Weeds on Property	404 N 4th Street
20260376	5/19/2026	Weeds	Overgrown Grass and Weeds on Property	1804 Grant
20260375	5/18/2026	Code	black recliner on front porch	1200 N 15th Street

## Exhibit "C"

20260370	5/15/2026	Code	Couch on porch/patio	521 N 11th Street
20260368	5/14/2026	JMV		900 Carlyle Street
20260367	5/14/2026	JMV		1522 N 8th Street
20260357	5/13/2026	JMV		1823-1821 Washington Street
20260356	5/13/2026	JMV		1315 Washington Street
20260355	5/13/2026	JMV		1809 William Drive
20260354	5/13/2026		Overgrown grass and weeds, needs sprayed to prevent thistle	
20260353	5/13/2026	Weeds	Overgrown grass and weeds, needs sprayed to prevent thistle	
20260351	5/13/2026	Weeds	Overgrown grass and weeds on property	425 S 7th Street
20260350	5/13/2026	Weeds	Overgrown grass and weeds on property	1300 High Street
20260349	5/13/2026	Weeds	Overgrown grass and weeds on property	1314-1316 Jefferson
20260348	5/12/2026			1300 Jefferson Street
20260347	5/12/2026	Code	Couch on front porch	1022 N 8th Street
20260346	5/12/2026	Code	Brown recliner sitting in driveway	1007 N 13th Street
20260344	5/12/2026	Code	Mattresses in back leaning on garage, Refrigerator sitting on front porch	408 N 8th Street
20260343	5/8/2026	Weeds	Overgrown grass and weeds on porperty	2009-2011 S 5th Avenue
20260342	5/8/2026	Weeds	Overgrown grass and weeds n property	1801 S 4TH
20260301	5/7/2026	JMV		616 Paddock Street
20260300	5/7/2026	JMV		616 Paddock Street
20260299	5/7/2026	JMV		901 N 7th Street
20260298	5/7/2026	Code	Junk/trash/plastic bins and totes in front yard and back yard. Mattress in front yard. Stack of Pallets in back yard.	520 S 10th Street
20260297	5/7/2026	Code	Mattress sitting in back along the alley and garage.	1017 Elk Street

## Exhibit "C"

20260291	5/6/2026	Weeds	overgrown grass and weeds on property	1110 E Court Street
20260290	5/6/2026	Weeds	Overgrown grass and weeds on property	110 S 13th Street
20260288	5/5/2026	Weeds	Overgrown grass and weeds on property	915 N 10th
20260287	5/5/2026	Code		1323 Woodland Avenue
20260286	5/5/2026	Weeds	Overgrown grass and weeds on property	905 N 10th Street
20260285	5/5/2026	Weeds	Overgrown grass and weeds on property	711 N 10th
20260284	5/5/2026	Code	patio furniture left out by sidewalk and street	1713-1715 WENTWORTH
20260282	5/5/2026	Weeds	Overgrown grass and weeds on property	1023 Scott Street
20260281	5/5/2026	Weeds	Overgrown grass and weeds on property	1205 Bell
20260280	5/5/2026	Weeds	Overgrown grass and weeds on property	1122 Bell Street
20260279	5/5/2026	Weeds	Overgrown grass and weeds on property	400-406 N 11th Street
20260278	5/5/2026		Overgrown grass and weeds on property	NW corner of 11th and Highs Streets
20260277	5/5/2026	JMV		1109 Ashland Avenue
20260273	5/4/2026	Code		1811 Grant Street
20260272	5/4/2026	Code	Couch sitting in driveway	1320 Lincoln Street
20260271	5/4/2026	Code	kitchen chair, and dismantled dresser sitting in front yard along street	1717 N 9th Street
20260269	5/4/2026	JMV		1425 N 9th Street
20260268	5/4/2026	JMV		1425 N 9th Street
20260267	5/4/2026	Code	Car parts surrounding garage, tires along garage, stack of tires in between house and garage.	520 N 9th Street
20260266	5/4/2026	JMV		520 N 9th Street
20260265	5/1/2026	JMV	Tan camper sitting in required front yard. mattresses sitting on top of boat in driveway. Camper not parked on improved parking.	1301 Lincoln Street

## Exhibit "C"

20260264	5/1/2026	JMV		1301 Lincoln Street
20260263	5/1/2026	Code	pile of branches (complaint)	00512 N 8TH
20260261	5/4/2026	JMV		520 N 9th Street
20260260	4/30/2026	Weeds	Overgrown grass and weeds on property	1700 Lincoln Street
20260258	4/30/2026	Weeds	Overgrown grass and weeds on porperty	1422 Lincoln
20260255	4/30/2026	Weeds	Overgrown grass and weeds on property	1425 Lincoln Street
20260251	4/30/2026	Weeds	Overgrown grass and weeds on property	1123 Lincoln Street
20260250	4/30/2026	Weeds	Overgrown grass and weeds on property	809 Lincoln Street
20260248	4/29/2026	Weeds	Overgrown grass and weeds on property	312 N 8th Street
20260247	4/29/2026	Weeds	Overgrown grass and weeds on property	1210 N 8Tth
20260246	4/29/2026	Weeds	Overgrown grass and weeds on property	1223 N 8th Street
20260245	4/29/2026	Weeds	Overgrown grass and weeds on property	1005 N 7th Street
20260244	4/29/2026	Weeds	Overgrown grass and weeds on property	1014 N 6th Street
20260239	4/29/2026	Weeds	Overgrown grass and weeds on property	1123 S 6th Street
20260237	4/29/2026	Weeds	Overgrown grass and weeds on property	1624 Country Club Lane
20260236	4/29/2026	Weeds	Overgrown grass and weeds on property	520 S 10th Street
20260232	4/29/2026	Code	Large pile of junk/trash along the street	1520 Market Street
20260231	4/29/2026	Code		425 S 7th Street
20260229	4/29/2026	Code	Pile of car parts on east side of the house, car parts along driveway and garage, tires sitting along alley and sidewalk	1700 Ella Street
20260228	4/28/2026	Code	Trash/Junk/Scrap metal filled up the back yard and in front of garage almost getting into the alleyway	1008 Elk Street
20260222	4/27/2026	Code	drawers/shelves scrap lumber in between street and sidewalk	1000 N 9th Street

## Exhibit "C"

20260221	4/27/2026	Weeds	Overgrown weeds and grass on property	422 S 9th Street
20260220	4/27/2026	Weeds	Overgrown weeds and grass on property	418 N 11th Street
20260219	4/27/2026	Weeds	Overgrown weeds and grass on property	1023 Market Street
20260218	4/27/2026	Weeds	Overgrown weeds and grass on property	1001 Market Street
20260217	4/27/2026	Weeds	Overgrown weeds and grass on property	718 Bell Street
20260215	4/27/2026	Weeds	Overgrown weeds and grass on property	1511 Bell Street
20260213	4/27/2026	Weeds	Overgrown weeds and grass on property	1024 Scott Street
20260212	4/27/2026	Weeds	Overgrown weeds and grass on property	1012 Scott Street
20260211	4/27/2026	Weeds	Overgrown weeds and grass on property	1004 Scott Street
20260210	4/27/2026	Weeds	Overgrown grass and weeds on propety	904 Scott Street
20260207	4/21/2026	Code	Large pile of junk/trash that was denied or didn't sign up for city wide clean up. Mattresses and junk on the north side of the house and cardboard on the south side of the house.	716 N 10th Street
20260203	4/21/2026	Code	Tires out along the street, declined from city wide cleanup	1700 Ella Street
20260198	4/17/2026	Code	Broken Windows on the southern part of the building (complaint received)	212 N 6th Street
20260196	4/16/2026	JMV		718 N 12th Street
20260194	4/15/2026	JMV		718 N 12th Street
20260193	4/15/2026	Code	Junk in driveway, plastic tubs, bins, sink, other random junk	311 S 8th Street
20260192	4/15/2026	Code	trash bags and junk lined up in front of garage	2015 Ella Street
20260191	4/15/2026	Code	Couches and mattresses on front porch.	818 N 4th Street
20260190	4/9/2026	Code	scrap lumper, cardboard boxes, part of a recliner/ottoman, shelving unit at the corner of 16th Street and Jackson Street, tires along garage. chair,	1103 N 16th Street
20260189	4/9/2026	Code	Front porch falling in. Front porch post is caving in.	1014 Court Street

## Exhibit "C"

20260188	4/9/2026	Code	Mattress in back of pick up truck.	1005 Bell Street
20260183	4/9/2026	Code	Couch/Junk in front lawn, by the sidewalk	120 Graham Street
20260182	4/9/2026	Code	Pile of used and scrap lumber at back of the house.	414 N Sumner Street
20260178	4/3/2026	JMV		1007 N 14th Street
20260176	4/3/2026	JMV		426 N 13th Street
20260172	4/2/2026	Zoning	White car, parked in required front yard.	1219 Jefferson Street
20260169	4/1/2026	Code	Tan Couch on front porch	823 Market Street
20260168	3/31/2026	JMV		201 S Lasalle Street
20260167	3/31/2026	JMV		503 W Scott Street
20260164	3/31/2026	JMV		1301 Court Street
20260163	3/31/2026	JMV		1301 Court Street
20260160	3/27/2026	Code	Refridgerator sitting along driveway	1400 Park Street
20260158	3/27/2026	Code	tires and hot water heater sitting in driveway	1409 Ashland Avenue
20260147	3/23/2026	Code	Large hole in roof, shingles are past their life and need replaced.	717 Market Street
20260146	3/23/2026	Zoning	Parking in required front yard,	1623 N 19th Street
20260141	3/19/2026	Weeds	Overgrown volunteer trees growing within fenceline.	922 Bell Street
20260140	3/19/2026	Dilapidated	Detached garage roof has multiple holes throughout, big hole in siding.	922 Bell Street
20260138	3/18/2026	JMV		1310 Washington Street
20260137	3/18/2026	JMV		1310 Washington Street
20260135	3/18/2026	JMV		1100 N 12th Street
20260123	3/12/2026	Code	Recliner sitting in the back, tires along back of house.	925 N 5th Street
20260122	3/12/2026	Code	Recliner on front porch	902 Market Street

## Exhibit "C"

20260119	3/10/2026	Code	Junk and trash all around back yard and driveway. Scrap lumber and fence panels, pallets, windows and other building materials, paint cans next to driveway, cardboard boxes, plastic bins, pile of junk next to driveway in back yard. (complaint received)	519 S 12th Street
20260116	3/5/2026	JMV		1723 High Street
20260115	3/5/2026	Zoning	Gray canvas car port put up with no permit. not meeting setbacks. Scrap lumber throughout property. Junk and trash littered around driveway. Plastic totes, bins surrounding the driveway. Various hunting material throughout property. scrap lumber and wood along alleyway and plastic and trash along alleyway. (complaint received)	1723 High Street
20260112	3/5/2026	Code	Recliner on front porch	601 N 9th Street
20260110	3/4/2026	Code	Tires and destroyed cabinet at the back of the house	210 N 9th Street
20260109	3/3/2026	Code	scrap wood lined up along garage	1518 Washington Street
20260106	3/18/2026	Code	Recliner sitting on front porch	601 S 10th Street
20260102	2/26/2026	Code	car parts, scrap metal all around garage and car	823 Bell Street
20260099	2/25/2026	Code	Recliner sitting on front porch	600 S 8th Street
20260098	2/25/2026	Code	Junk/Trash on front porch, junk/trash/toilet sitting next to the street. Recliner on front porch.	808 Perkins Street
20260097	2/25/2026	JMV		1120 Market Street
20260094	2/24/2026	Code		801 Ella Street
20260089	3/1/2026	JMV		1115 S 3rd Avenue
20260088	3/24/2026	JMV		1115 S 3rd Avenue
20260087	3/24/2026	JMV		1115 S 3rd Avenue
20260086	2/20/2026	JMV		529 Ella Street
20260085	2/20/2026	JMV		529 Ella Street

## Exhibit "C"

20260081	2/18/2026	Code	Couch sitting on front porch.	1006 Ella Street
20260077	2/17/2026	Code	Watching, cat house.	511 N 10th Street
20260073	2/13/2026	JMV		1713 Monroe Street
20260068	2/12/2026	JMV		330 S 21st Street
20260051	2/2/2026	Permit Violation	Dirt being hauled in to flood area on property. No flood district development paperwork filed.	
20260048	1/30/2026	JMV		916 Ella Street
20260021	1/22/2026	Zoning	wrong fence materials being used to put up fence	1426 N 8th Street
20260020	1/22/2026	Code	Mattresses in the backyard	400-406 N 11th Street
20260017	2/20/2026	Code	Refridgerator on the side of the garage.	1022 Herbert Street
20260007	1/7/2026	Code	Significant fire, heat and smoke damage to banquet room and restaurant	403 Court Street

**CLOSED IN MAY: 71**

Case #	Date Opened	Violation	Reason for Violation	Location
20260262	5/1/2026	Code	Cardboard box from tv, branches along side of the house and next to tv box. (complaint received)	240 S 19TH
20260270	5/4/2026	Code	Pile of junk on the sidewalk next to the street. Mattress, plastic bins and totes, cardboard boxes	820 Irving Street
20260274	5/4/2026	Code	2 mattresses on the front porch	902 Market Street
20260275	5/5/2026	Code	3 Couches, junk/trash and table along sidewalk and street	724 W Mary Street
20260276	5/5/2026	Code	couch out against the street	820 W Court Street
20260283	5/5/2026	Weeds	Overgrown grass and weeds on property	1022 Scott Street
20260289	5/5/2026	Weeds	Overgrown grass and weeds on property	821 N 11th Street
20260292	5/6/2026	Weeds	Overgrown grass and weeds on property	518 W Court
20260293	5/7/2026	Temp. Signs	temp sign to close to roadway.	
20260294	5/7/2026	Temp. Signs	temp sign not set back 10'	323 S 16th Street

## Exhibit "C"

20260295	5/7/2026	Temp. Signs	temp sign next to street. not set back 10'	1526 Scott Street
20260296	5/7/2026	Code	Mattresses on front porch	902 Market Street
20260302	5/8/2026	Temp. Signs	temp sign not set back 10', on city property.	
20260303	5/8/2026	Temp. Signs	temp sign not set back 10', on city property.	
20260304	5/8/2026	Temp. Signs	temp sign not set back 10', on city property.	
20260305	5/8/2026	Temp. Signs	temp sign not set back 10', on city property.	
20260306	5/8/2026	Temp. Signs	temp sign not set back 10', on city property.	
20260307	5/8/2026	Temp. Signs	temp sign not set back 10', on city property.	
20260308	5/8/2026	Temp. Signs	temp sign not set back 10', on city property.	00401 W SCOTT
20260309	5/8/2026	Temp. Signs	temp sign not set back 10', on city property.	00424 SCOTT
20260310	5/8/2026	Temp. Signs	temp sign not set back 10', (complaint received)	00300 THAYER
20260311	5/8/2026	Temp. Signs	temp sign not set back 10', (complaint received)	00311 THAYER
20260312	5/8/2026	Temp. Signs	temp sign not set back 10', (complaint received)	00232 S LASALLE
20260313	5/8/2026	Temp. Signs	temp sign not set back 10', (complaint received)	00233 S LASALLE
20260314	5/8/2026	Temp. Signs	temp sign not set back 10', (complaint received)	201 S Lasalle Street
20260315	5/8/2026	Temp. Signs	temp sign not set back 10', (complaint received)	00200 S LASALLE
20260316	5/8/2026	Temp. Signs	temp sign not set back 10', (complaint received)	
20260317	5/8/2026	Temp. Signs	temp sign not set back 10', (complaint received)	320 S 16TH
20260318	5/8/2026	Temp. Signs	temp sign not set back 10', (complaint received)	323 S 16th Street
20260319	5/8/2026	Temp. Signs	temp sign not set back 10', (complaint received)	Beatrice Water Park
20260320	5/8/2026	Temp. Signs	temp sign not set back 10', (complaint received)	1508 Scott Street
20260321	5/8/2026	Temp. Signs	temp sign not set back 10', (complaint received)	1400 SCOTT

## Exhibit "C"

20260322	5/8/2026	Temp. Signs	temp sign not set back 10', (complaint received)	Beatrice Water Park
20260323	5/8/2026	Temp. Signs	temp sign not set back 10', (complaint received)	1518 Scott Street
20260324	5/8/2026	Temp. Signs	temp sign not set back 10', (complaint received)	Beatrice Water Park
20260325	5/8/2026	Temp. Signs	temp sign not set back 10', (complaint received)	Beatrice Water Park
20260326	5/8/2026	Temp. Signs	temp sign not set back 10', (complaint received)	Beatrice Water Park
20260327	5/8/2026	Temp. Signs	temp sign not set back 10', (complaint received)	Beatrice Water Park
20260328	5/8/2026	Temp. Signs	temp sign not set back 10', (complaint received)	006TH & BEAVER
20260329	5/8/2026	Temp. Signs	temp sign not set back 10', (complaint received)	006TH & BEAVER
20260330	5/8/2026	Temp. Signs	temp sign not set back 10', (complaint received)	006TH & BEAVER
20260331	5/8/2026	Temp. Signs	temp sign not set back 10', (complaint received)	1522 S 6th Street
20260332	5/8/2026	Temp. Signs	temp sign not set back 10', (complaint received)	
20260333	5/8/2026	Temp. Signs	temp sign not set back 10', (complaint received)	01803 S 8TH
20260334	5/8/2026	Temp. Signs	temp sign not set back 10', (complaint received)	Parcel 012397000, 1200 block of Oak Street
20260335	5/8/2026	Temp. Signs	temp sign not set back 10', (complaint received)	
20260336	5/8/2026	Temp. Signs	temp sign not set back 10', (complaint received)	Parcel 012397000, 1200 block of Oak Street
20260337	5/8/2026	Temp. Signs	temp sign not set back 10', (complaint received)	01300 COUNTRY CLUB LN
20260338	5/8/2026	Temp. Signs	temp sign not set back 10', (complaint received)	
20260339	5/8/2026	Temp. Signs	temp sign not set back 10', (complaint received)	1700 S 13th Street
20260340	5/8/2026	Temp. Signs	temp sign not set back 10', (complaint received)	905 Beaver Avenue
20260341	5/8/2026	Temp. Signs	temp sign not set back 10', (complaint received)	01200 BEAVER
20260345	5/12/2026	JMV		1300 Jefferson Street
20260352	5/13/2026	JMV		1315 Washington Street

## Exhibit "C"

20260358	5/14/2026	Temp. Signs	temp sign not setback 10' from curb.	509 S 11th Street
20260359	5/14/2026	Temp. Signs	temp sign not setback 10' from curb.	
20260360	5/14/2026	Temp. Signs	temp sign not setback 10' from curb.	722 S 12th Street
20260361	5/14/2026	Temp. Signs	temp sign not setback 10' from curb.	824 S 11th Street
20260362	5/14/2026	Temp. Signs	temp sign not setback 10' from curb.	800 S 10th Street
20260363	5/14/2026	Temp. Signs	temp sign not setback 10' from curb.	723 Holbrook Street
20260364	5/14/2026	Temp. Signs	temp sign not setback 10' from curb	601-603 S 11TH
20260365	5/14/2026	Temp. Signs	temp sign not setback 10' from curb	522 S 11th Street
20260366	5/14/2026	Temp. Signs	temp sign not setback 10' from curb	600 S 11TH
20260369	5/14/2026	Code	chair on front porch.	416 N 13th Street
20260371	5/18/2026	Temp. Signs	temp sign, not setback 10' from curb.	
20260372	5/18/2026	Temp. Signs	temp sign not setback 10' from curb	02124 MARKET
20260373	5/18/2026	Temp. Signs	temp sign not setback 10' from curb	2120 Market Street
20260374	5/18/2026	Temp. Signs	temp sign, not set back 10' from curb.	1823 Market Street
20260380	5/21/2026	Temp. Signs	temp sign, not set back 10' from curb. too close to street	2227 E Court Street
20260381	5/21/2026	Temp. Signs	temp sign, not set back 10' from curb. too close to S 23rd street	2301 E Court Street
20260382	5/21/2026	Temp. Signs	temp sign, not set back 10' from curb. too close to court street	2301 E Court Street

## PERMIT SUMMARY REPORT

	May 2026	May 2025	Current Year-to-Date 2026	Last Year-to-Date 2025
Administrative Setback Adjustment (Zoning)				
Count	0	0	2	2
Fees Paid	\$ -	\$ -	\$ 100.00	\$ 50.00
Administrative Subdivision Application (Zoning)				
Count	0	1	5	3
Fees Paid	\$ -	\$ 116.00	\$ 664.00	\$ 338.00
Appeals Application				
Count	0	0	0	0
Fees Paid	\$ -	\$ -	\$ -	\$ -
Building Permit Application				
Count	17	40	92	140
Fees Paid	\$ 5,735.95	\$ 24,166.48	\$ 96,694.14	\$ 96,058.85
Change of Occupancy				
Count	0	0	0	0
Fees Paid	\$ -	\$ -	\$ -	\$ -
Demolition Permit Application				
Count	0	1	6	15
Fees Paid	\$ -	\$ 5.00	\$ 55.00	\$ 60.00
Encroachment Permit Application				
Count	5	2	30	22
Fees Paid	\$ 290.00	\$ 40.00	\$ 1,085.00	\$ 500.00
Final Plat Application (Zoning)				
Count	0	0	4	2
Fees Paid	\$ -	\$ -	\$ 602.00	\$ -
Flood District Development Permit				
Count	0	0	2	0
Fees Paid	\$ -	\$ -	\$ 50.00	\$ -
Hobbyist Vehicle Permit				
Count	0	0	0	1
Fees Paid	\$ -	\$ -	\$ -	\$ 50.00
Inquiry				
Count	0	2	1	5
Fees Paid	\$ -	\$ -	\$ -	\$ -
Mechanical Permit Application				
Count	3	2	6	9
Fees Paid	\$ 260.00	\$ 190.00	\$ 400.00	\$ 470.00
Moving Permit Application				
Count	0	0	0	2
Fees Paid	\$ -	\$ -	\$ -	\$ 200.00
Mow-to-Own				
Count	0	0	0	0
Fees Paid	\$ -	\$ -	\$ -	\$ -
Plumber Registration				
Count	0	2	9	41
Fees Paid	\$ -	\$ 100.00	\$ 240.00	\$ 1,162.00
Plumbing Permit Application				
Count	3	3	14	10
Fees Paid	\$ 618.00	\$ 158.00	\$ 2,332.00	\$ 552.00
Preliminary Plat Application				
Count	0	0	0	0
Fees Paid	\$ -	\$ -	\$ -	\$ -
Racecar Permit				
Count	0	0	0	0
Fees Paid	\$ -	\$ -	\$ -	\$ -
Re-Zoning Application				
Count	0	0	1	2
Fees Paid	\$ -	\$ -	\$ 100.00	\$ 200.00
Sign Permit Application				
Count	3	0	12	9
Fees Paid	\$ 225.00	\$ -	\$ 900.00	\$ 675.00

## PERMIT SUMMARY REPORT

	May 2026	May 2025	Current Year-to-Date 2026	Last Year-to-Date 2025
Special Use Permit (Zoning)				
Count	1	2	3	5
Fees Paid	\$ 116.00	\$ 226.00	\$ 316.00	\$ 542.00
Vacate Public Ways				
Count	0	0	0	0
Fees Paid	\$ -	\$ -	\$ -	\$ -
Water Tap				
Count	0	0	0	0
Fees Paid	\$ -	\$ -	\$ -	\$ -
Zoning Verification				
Count	0	0	0	0
Fees Paid	\$ -	\$ -	\$ -	\$ -
Voided Permits	3	0	12	2
<b>TOTAL COUNT</b>	<b>35</b>	<b>55</b>	<b>199</b>	<b>\$ 270</b>
<b>TOTAL FEES PAID</b>	<b>\$ 7,244.95</b>	<b>\$ 25,001.48</b>	<b>\$ 103,538.14</b>	<b>\$ 100,857.85</b>

**MONTHLY BUILDING PERMIT APPLICATIONS**  
**5/1/26 to 5/31/26**

Permit #	Permit Date	Description	Owner Name	Parcel Address	Parcel #	Total Fees	Total Valuation	Primary Contractor
20260196	5/27/2026	Drain System, sump pump	Jay D & Jeannine M Murphy	1839 Carlyle Street	015186000	104.25	4,500.00	Epp Concrete
20260193	5/26/2026	garage	Frannkie Clarke	510 W Park Street	011701000	391.25	25,000.00	Gene Roeber Construction
20260192	5/26/2026	Install CF, sump pump basement gutter system	Mark A & Jodee L Hawkins	1620 N 11th Street	011352000	201.96	11,479.00	Groundworks
20260189	5/19/2026	Stairs	Jeremy Huttenmaier	312 S 24th Street	015176000	125.00	3,000.00	Madison Home Repair services
20260188	5/20/2026	Tower (T-mobile)			005158100	643.75	50,000.00	Vinco
20260183	5/15/2026	Garage Addition	John T & Jean T Brazell, Trustees	2109 S 19th Street	014721508	542.75	40,000.00	Pickrell Lumber Company
20260178	5/12/2026	7 Brew		548 Irving Street	012409603	2,673.75	400,000.00	Atlas Modular LLC
20260177	5/11/2026	Siding	Ellie Jean Leners	1419 Wentworth	011700000	76.25	2,500.00	Owner
20260173	5/6/2026	Fix Bowing Wall	Trey Brewer	1825 Hoyt	011168000	226.89	13,260.17	
20260167	5/1/2026	accessory structure 14x20	David A & Beth A Sederberg	2000 High Street	010397000	265.25	16,000.00	
20260165	5/1/2026	Roof over patio	Rayburn, David J & Mary C	100 W Mulberry	014683000	109.85	4,900.00	S & M Construction

## DEMOLITION PROJECTS

The dilapidated structures process starts with compiling evidence and continues until the structure is demolished. This process is essentially a 16-step process with various timelines/deadlines that have to be adhered to. The following information will provide you a better understanding of where we are with removing dilapidated structures:

	Address	Status	Notes
1	820 Market Street	City to demo/held up	Condemned by City. Ready for demo.
2	1617 Court Street	Owner to Demo	Dilapidated garage
3	517 S 10th Street	Owner to Demo	Demo garage
4	321 N 20th Street	Owner to Demo	Demo garage
5	424 N 17th Street	Owner to Demo	Demo Garage
6	1013 Court Street	Owner to Demo	Demo house
7	1115 S 3rd Street	Pending	City condemned property. Unfit and unsafe for human habitation
8	903 Grant Street	Owner to Demo	Small garage
9	Parcel 004148000	Owner to Demo	Barn on new Landmark Snacks location
10	1023 Bell Street	Owner to Demo	Small Garage
11	1109 Park Street	Owner to Demo	Small shed
12	1606 Dorsey Street	Owner to Demo	House

### DEMO PROCESS:

Receive complaint

Compile evidence

- 1 Send owner intent letter and inspection request
- 2 Owner responds and will comply – Monitor progress
- 3 Obtain Inspection Warrant
- 4 Serve Inspection Warrant
- 5 Order title search
- 6 Condemn property
- 7 Notice and Order all with legal interest
- 8 Disconnect BPW utilities
- 9 Prepare Affidavit of Service
- 10 File Certificate of Substandard Building
- 11 Schedule appeals hearings (if necessary)
- 12 Obtain demolition quotes
- 13 Have local utilities shut off
- 14 Demolition

**SPECIAL DESIGNATED LICENSES (SDLs) REQUESTED IN 2026**

<b>Name</b>	<b>Date of Event</b>	<b>Location of Event</b>	<b>Date Approved</b>	<b>By</b>
Tall Tree Tastings	3/3/2026	Beatrice Community Hospital	1/13/2026	ES
Beatrice Mary Family YMCA	2/28/2026	Beatrice Mary Family YMCA	1/19/2026	CC
Tall Tree Tastings	4/28/2026	Beatrice Public Library	4/6/2026	CC
Stone Hollow Brewing Company	4/30/2026 - 5/3/2026	Envision Landscapes	4/6/2026	ES
402 Sports Bar & Grill	6/26 & 6/27/2026	402 Sports Bar	4/17/2026	ES
Eagles Club	5/16 & 5/17/2026	Eagles Club	4/27/2026	ES
Micheal J's	5/30/2026	Micheal J's	5/8/2026	ES
Community Players, Inc.	6/4-6/6/26 & 6/11-6/13/26	Community Players Theatre	5/11/2026	ES
Stone Hollow Brewing Co, LLC	6/20/2026	Merchantile Building	5/26/2026	ES
Stone Hollow Brewing Co, LLC	6/27/2026	Merchantile Building	5/26/2026	ES
American Legion Bitting-Norman Post #27	6/12/2026	American Legion	5/26/2026	ES
The Mechanical Room	6/27/2026	Merchantile Building	6/11/2026	ES

**SELL or PEDDLE GOODS REQUESTED IN 2026**

<b>Name</b>	<b>Date of Event</b>	<b>Location of Event</b>	<b>Date Approved</b>	<b>By</b>
Food for Hope	June 7 ; July 5; Aug 2; Sept 6	Chautauqua Park Tabernacle	4/13/2026	ES
Gage Coalition	June 25-28, 2026	Various City properties for Homestead Days	6/8/2026	ES