

Regular Meeting
Monday, March 11, 2024 7:00 PM

Franklin Public Schools Media Center
1001 M St
Franklin, NE 68939

Agenda

1. Call the Meeting to Order
2. Pledge of Allegiance
3. Roll Call
4. Excuse Absent Board Members
5. Verification of Open Meetings Act Notice
6. Verification of Publication of Meeting Notice
7. FCCLA Presentation
8. Action Items
 - 8.1. Consent Agenda
 - 8.1.1. Minutes of Previous Meeting
 - 8.1.2. Monthly Financial Report
 - 8.1.3. Claims
 - 8.2. Discuss and accept the resignation of Mr. Timothy Ellis, K-12 vocal music teacher at the end of the 2023-2024 school year
 - 8.3. Discuss and accept the resignation of Mrs. Shay Baumgart, 5th grade teacher at the end of the 2023-2024 school year
 - 8.4. Consider, discuss and approve a contract for Mrs. Brenda Alberts, MS math teacher for the 2024-2025 school year.
 - 8.5. Consider, discuss and approve a contract for Mrs. Melissa Haack, HS math teacher for the 2024-2025 school year.
 - 8.6. Consider, discuss and approve providing \$120 per Franklin Public Schools' students who choose to participate in the Driver's Education Program provided at Franklin Public Schools through the Nebraska Safety Center during the Summer of 2024.
 - 8.7. Consider, discuss and approve purchasing and payment from the Activity Fund of four basketball backboard kits as presented to upgrade the system for the upcoming NSAA shot clock regulations.
 - 8.8. Consider, discuss and approve EMC and/or ALICAP as Franklin Public Schools' insurance provider as well as the payment of the premium.
 - 8.9. Consider, discuss and approve a 3% salary increase for classified staff for the 2024-2025 school year.
 - 8.10. Consider, discuss and approve a 2.2% salary increase for the administrators for the 2024-2025 school year.
9. Activities Director's Report / Technology Director's Report
10. Elementary Principal's Report
11. Secondary Principal's Report
12. Superintendent's Report
13. Positive Comments

14. Executive Session - To discuss personnel for the protection of public interest and/or the prevention of needless injury to the reputation of an individual and if such individual has not requested a public meeting.
15. Adjournment

Regular Meeting

Tuesday, February 13, 2024 7:00 PM

1. Call the Meeting to Order

The regular meeting of the Franklin Public School Board was opened at 7:00 PM.

2. Pledge of Allegiance

3. Roll Call

Attendance Taken at 7:01 PM. **Absent:** Derek Fouts, **Present:** Michael Bartels, Angie Grube, Brandon Herrick, Windy Ingram, Harley Scott. Present: 5, Absent: 1.

4. Excuse Absent Board Members

Motion to excuse Derek Fouts whom is absent from the meeting passed with a motion by Angie Grube and a second by Harley Scott.

Derek Fouts: Absent, Michael Bartels: Yea, Angie Grube: Yea, Brandon Herrick: Yea, Windy Ingram: Yea, Harley Scott: Yea

5. Verification of Open Meetings Act Notice

Board Member Windy Ingram verified that the Open Meetings Notice was posted in the Franklin Public School's Media Center.

6. Verification of Publication of Meeting Notice

Board Member Brandon Herrick verified that the meeting notice was published in the Franklin Chronicle.

7. Consider and Approve the Current Board Meeting Agenda

Motion to approve the current month's board meeting agenda as presented passed with a motion by Harley Scott and a second by Angie Grube.

Derek Fouts: Absent, Michael Bartels: Yea, Angie Grube: Yea, Brandon Herrick: Yea, Windy Ingram: Yea, Harley Scott: Yea

8. Action Items

8.1. Consent Agenda

Motion to approve consent agenda passed with a motion by Harley Scott and a second by Angie

Grube.

Derek Fouts: Absent, Michael Bartels: Yea, Angie Grube: Yea, Brandon Herrick: Yea, Windy Ingram: Yea, Harley Scott: Yea

8.1.1. Minutes of Previous Meeting

8.1.2. Monthly Financial Report

8.1.3. Claims

8.2. Discuss and accept the resignation of Mr. Riley Mrkvicka, MS math teacher at the end of the 2023-2024 school year

Motion to accept the resignation of Mr. Riley Mrkvicka, MS math teacher at the end of the 2023-2024 school year passed with a motion by Harley Scott and a second by Windy Ingram.

Derek Fouts: Absent, Michael Bartels: Yea, Angie Grube: Yea, Brandon Herrick: Yea, Windy Ingram: Yea, Harley Scott: Yea

8.3. Discuss and accept the resignation of Mrs. Linea Bonham, MS english teacher at the end of the 2023-2024 school year

Motion to accept the resignation of Mrs. Linea Bonham, MS english teacher at the end of the 2023-2024 school year passed with a motion by Windy Ingram and a second by Angie Grube.

Derek Fouts: Absent, Michael Bartels: Yea, Angie Grube: Yea, Brandon Herrick: Yea, Windy Ingram: Yea, Harley Scott: Yea

8.4. Discuss and accept the resignation of Ms. Emily Cleveland, HS math teacher at the end of the 2023-2024 school year

Motion to accept the resignation of Ms. Emily Cleveland, HS math teacher at the end of the 2023-2024 school year passed with a motion by Harley Scott and a second by Angie Grube.

Derek Fouts: Absent, Michael Bartels: Yea, Angie Grube: Yea, Brandon Herrick: Yea, Windy Ingram: Yea, Harley Scott: Yea

8.5. Consider, Discuss and Approve the 2024-2025 Master Services Agreement between the Educational Service Unit # 11 and Franklin Public Schools

Motion to Approve the 2024-2025 Master Services Agreement between the Educational Service Unit # 11 and Franklin Public Schools passed with a motion by Windy Ingram and a second by Brandon Herrick.

Derek Fouts: Absent, Michael Bartels: Yea, Angie Grube: Yea, Brandon Herrick: Yea, Windy Ingram: Yea, Harley Scott: Yea

8.6. Consider, Discuss and Approve the 2024-2025 Franklin Public Schools Calendar as presented

The presented 2024-2025 Franklin Public Schools Calendar passed with a motion by Harley

Scott and a second by Michael Bartels.

Derek Fouts: Absent, Michael Bartels: Yea, Angie Grube: Yea, Brandon Herrick: Yea, Windy Ingram: Yea, Harley Scott: Yea

9. Activities Director's Report / Technology Director's Report

10. Elementary Principal's Report

11. Secondary Principal's Report

12. Superintendent's Report

13. Positive Comments

The recent Parent-Teacher Conference was successful. A continued thank you to the Administration for all they do!

Proud of all the recent FPS accomplishments!!!

Kaiya Bislow: 1st place in the Franklin County Spelling Bee

FHS Wrestling Team with their recent tournaments. Grant Haussermann, Carter Trambly, Calvin Carraher and Caury Twohig are heading to State Wrestling!

Declan Liechti: being part of the elite solo squad in Sing Across Nebraska

FFA seniors participating in the state degree interviews

14. Executive Session - To discuss personnel for the protection of public interest and/or the prevention of needless injury to the reputation of an individual and if such individual has not requested a public meeting.

The School Board did not enter into executive session.

15. Adjournment

Meeting to adjourn at 8:17 PM passed with a motion by Brandon Herrick and a second by Michael Bartels.

Derek Fouts: Absent, Michael Bartels: Yea, Angie Grube: Yea, Brandon Herrick: Yea, Windy Ingram: Yea, Harley Scott: Yea

CAFETERIA PLAN -- FLEX BENEFITS PLAN

Statement Date: February 29, 2024

FPS Financial Software -- Account Balance

Checking Account Beginning of Month Balance on Hand:	\$22,694.06
--	-------------

Cash Receipts:

Transfer from Gen Fund to "Start Up" New School Year	\$0.00
--	--------

Monthly Reimbursement from Gen Fund Employee Payroll	\$1,279.17
--	------------

Expenses:

Transfer to Gen Fund for "Start Up" Reimbursement	\$0.00
---	--------

Employee Med-I-Bank Direct Pay	-\$2,657.93
--------------------------------	-------------

Checking Account End of Month Balance on Hand:	\$21,315.30
---	--------------------

Grand Total: \$21,315.30

Bank Statement -- Account Balance

Checking Account Balance this Statement:	\$21,315.30
--	-------------

Cash Receipts Outstanding	\$0.00
---------------------------	--------

Expenses Outstanding	\$0.00
----------------------	--------

Checking Account End of Month Balance on Hand:	\$21,315.30
---	--------------------

Grand Total: \$21,315.30

01 -- GENERAL FUND

Statement Date: February 29, 2024

FPS Financial Software -- Account Balance

Checking Account Beginning of Month Balance on Hand: \$1,297,607.01

Cash Receipts:

Franklin County Treasurer \$378,465.00

Harlan County Treasurer \$7,715.75

Miscellaneous \$147,428.75

Interest \$285.97

Expenses:

Transfer to Cafeteria Plan for "Start Up" New School Year \$0.00

Invoice Checks Written this Month -\$59,827.99

Payroll Employees -\$163,939.49

Payroll Payees -\$179,591.88

Checking Account End of Month Balance on Hand: \$1,428,143.12

CD Account Beginning of Month Balance on Hand: \$1,281,902.34

Interest \$1,780.54

CD Account End of Month Balance on Hand: \$1,283,682.88

Grand Total: \$2,711,826.00

Bank Statement -- Account Balance

Checking Account Balance this Statement: \$1,430,189.37

Cash Receipts Outstanding \$0.00

Checks Outstanding -\$2,046.25

Checking Account End of Month Balance on Hand: \$1,428,143.12

CD Account Balance this Statement: \$1,283,682.88

Grand Total: \$2,711,826.00

Fund: 01 GENERAL FUND

Account Number	Description	Revised Budget	During Month	To Date	% of Budget	Budget Balance
01 1100	LOCAL PROPERTY TAXES, TRANSFERS	3,917,948.00	164,038.41	2,245,924.23	57.32	1,672,023.77
01 1115	CARLINE TAXES	100.00	0.00	22.60	22.60	77.40
01 1120	PUBLIC POWER DISTRICT SALES TAX 5% GROSS	10,000.00	590.71	3,279.24	32.79	6,720.76
01 1125	MOTOR VEHICLE TAX	120,000.00	43,235.59	85,701.69	71.42	34,298.31
01 1140	PENALTIES AND INTEREST ON TAXES	10,000.00	446.54	7,892.54	78.93	2,107.46
01 1370	PRESCHOOL TUITION AND FEES	16,875.00	825.00	9,075.00	53.78	7,800.00
01 1510	INTEREST ON INVESTMENTS	20,000.00	2,066.51	28,551.25	142.76	(8,551.25)
01 1911	LOCAL LICENSE FEES	1,000.00	0.00	950.00	95.00	50.00
01 1920	CONTRIBUTIONS & DONATIONS - PRIVATE SOURCE	1,000.00	2,500.00	8,200.00	820.00	(7,200.00)
Subtotal: LOCAL RECIEPTS		4,096,923.00	213,702.76	2,389,596.55	58.33	1,707,326.45
01 2110	COUNTY FINES & LICENSES	1,000.00	667.22	2,201.75	220.18	(1,201.75)
01 2130	OTHER COUNTY RECEIPTS	200.00	0.00	0.00	0.00	200.00
01 2210	ESU RECEIPTS	200.00	0.00	0.00	0.00	200.00
Subtotal: -		1,400.00	667.22	2,201.75	157.27	(801.75)
01 3110	STATE AID	608,000.00	60,809.00	364,854.00	60.01	243,146.00
01 3120	SPED (SCHOOL AGE)	300,000.00	74,166.00	221,756.00	73.92	78,244.00
01 3125	SPED TRANSPORTATION SCHOOL AGE	10,000.00	0.00	0.00	0.00	10,000.00
01 3130	HOMESTEAD EXEMPTION	40,000.00	0.00	0.00	0.00	40,000.00
01 3131	PROPERTY TAX CREDIT	320,000.00	177,208.19	177,208.19	55.38	142,791.81
01 3180	PRO-RATE MOTOR VEHICLE	8,000.00	(5.91)	3,062.98	38.29	4,937.02
01 3400	STATE APPORTIONMENT	35,000.00	0.00	40,805.62	116.59	(5,805.62)
01 3535	HIGH ABILITY LEARNERS	2,000.00	0.00	3,833.00	191.65	(1,833.00)
01 3551	CAREER EDUCATION (CTE)	0.00	7,500.00	7,500.00	0.00	(7,500.00)
01 3990	OTHER STATE RECEIPTS	50.00	0.00	0.00	0.00	50.00
Subtotal: -		1,323,050.00	319,677.28	819,019.79	61.90	504,030.21
01 4309	HEAD START	750.00	0.00	750.00	100.00	0.00
01 4310	REAP	24,384.00	0.00	0.00	0.00	24,384.00
01 4505	TITLE I PT A ESSA IMPROVING BASIC PROG	60,733.00	0.00	14,421.00	23.74	46,312.00
01 4509	TITLE II PT A ESSA EFFECTIVE INSTRUCTION	11,501.00	0.00	0.00	0.00	11,501.00
01 4516	IDEA PRESCH(619) BASE IDEA ENROLL/POVERT	1,163.00	0.00	0.00	0.00	1,163.00
01 4518	IDEA PART B (611) BASE POVERTY ALLOCATION	77,216.00	0.00	6,744.00	8.73	70,472.00
01 4525	FED VOC & APPLIED TECH ED (CARL PERKINS)	1,000.00	85.00	475.00	47.50	525.00
01 4708	MEDICAID IN PUBLIC SCHOOLS	5,000.00	0.00	8,058.90	161.18	(3,058.90)
01 4709	MEDICAID ADMINISTRATIVE ACTIVITIES	3,000.00	0.00	2,718.02	90.60	281.98
01 4969	TITLE IV, PART A SSAE	10,000.00	0.00	0.00	0.00	10,000.00
01 4998	ESSER III - ARP	56,430.00	450.00	9,466.34	16.78	46,963.66
Subtotal: -		251,177.00	535.00	42,633.26	16.97	208,543.74
01 5300	PROCEEDS FROM DISPOSAL OF REAL/PERS PROPERTY	500.00	0.00	0.00	0.00	500.00
01 5301	INSURANCE ADJUSTMENTS	300.00	500.00	2,613.55	871.18	(2,313.55)
Subtotal: NON REVENUE RECEIPTS - NOT USED		800.00	500.00	2,613.55	326.69	(1,813.55)
Fund Total:		5,673,350.00	535,082.26	3,256,064.90	57.39	2,417,285.10

02 -- DEPRECIATION FUND

Statement Date: February 29, 2024

FPS Financial Software -- Account Balance

Checking Account Beginning of Month Balance on Hand:	\$191,626.92
--	--------------

Cash Receipts:

Transfer from General Fund	\$0.00
----------------------------	--------

Miscellaneous	\$0.00
---------------	--------

Expenses:

Invoice Checks Written this Month	\$0.00
-----------------------------------	--------

Checking Account End of Month Balance on Hand:	\$191,626.92
---	---------------------

Grand Total: \$191,626.92

Bank Statement -- Account Balance

Checking Account Balance this Statement:	\$191,626.92
--	--------------

Cash Receipts Outstanding	\$0.00
---------------------------	--------

Checks Outstanding	\$0.00
--------------------	--------

Checking Account End of Month Balance on Hand:	\$191,626.92
---	---------------------

Grand Total: \$191,626.92

03 -- UNEMPLOYMENT INSURANCE FUND

Statement Date: February 29, 2024

FPS Financial Software -- Account Balance

Checking Account Beginning of Month Balance on Hand:	\$3,508.67
Cash Receipts:	
Miscellaneous	\$0.00
Interest	\$0.70
Expenses:	
Employee Benefit Checks Written this Month	\$0.00
Checking Account End of Month Balance on Hand:	\$3,509.37
CD Account Beginning of Month Balance on Hand:	\$4,151.34
Interest	\$0.00
CD Account End of Month Balance on Hand:	\$4,151.34
Grand Total:	\$7,660.71

Bank Statement -- Account Balance

Checking Account Balance this Statement:	\$3,509.37
Cash Receipts Outstanding	\$0.00
Checks Outstanding	\$0.00
Checking Account End of Month Balance on Hand:	\$3,509.37
CD Account Balance this Statement:	\$4,151.34
Grand Total:	\$7,660.71

05 -- ACTIVITY FUND

Statement Date: February 29, 2024

FPS Financial Software -- Account Balance

Checking Account Beginning of Month Balance on Hand: \$195,976.00

Cash Receipts:

Transfer from General Fund Replenishing Activity Fund \$0.00

Contributions, Miscellaneous \$4,933.20

Voided Checks \$20.00

Interest \$38.67

Expenses:

Invoice Checks Written this Month -\$20,100.49

Checking Account End of Month Balance on Hand: \$180,867.38

CD Account Beginning of Month Balance on Hand: \$23,083.21

Interest \$80.63

CD Account End of Month Balance on Hand: \$23,163.84

Grand Total: \$204,031.22

Bank Statement -- Account Balance

Checking Account Balance this Statement: \$187,218.75

Cash Receipts Outstanding \$0.00

Checks Outstanding -\$6,351.37

Checking Account End of Month Balance on Hand: \$180,867.38

CD Account Balance this Statement: \$23,163.84

Grand Total: \$204,031.22

Franklin Public Schools -- 05 Activity Fund Balance Report - Summary - February 2024

COA	COA Description	Beginning Balance	Expenses	Revenues	Balance
05 704 0001	ACTIVITIES	46,472.10	13,290.06	790.10	33,972.14
05 704 0003	CROSS COUNTRY	1,130.17	89.60	253.20	1,293.77
05 704 0004	BASKETBALL BOYS	1,767.68	0.00	0.00	1,767.68
05 704 0005	BASKETBALL GIRLS	2,154.94	0.00	0.00	2,154.94
05 704 0006	FOOTBALL	5,049.26	0.00	0.00	5,049.26
05 704 0007	GOLF	5,181.05	0.00	0.00	5,181.05
05 704 0008	TRACK	876.17	0.00	235.60	1,111.77
05 704 0010	VOLLEYBALL	4,231.20	250.89	0.00	3,980.31
05 704 0011	WRESTLING	4,006.47	816.66	321.00	3,510.81
05 704 0012	FPS SIGNWORX	221.19	0.00	0.00	221.19
05 704 0013	E-SPORTS	(1,283.94)	0.00	135.00	(1,148.94)
05 704 0015	YEARBOOK	3,649.95	0.00	450.00	4,099.95
05 704 0016	BAND / FLAGS	10,879.08	0.00	0.00	10,879.08
05 704 0017	CHEERLEADERS	1,730.47	0.00	0.00	1,730.47
05 704 0018	FPS COFFEE CART	600.47	311.12	0.00	289.35
05 704 0019	CONCESSIONS	8,028.01	1,669.52	1,423.80	7,782.29
05 704 0020	FCCLA	9,893.83	928.17	425.00	9,390.66
05 704 0021	FFA	18,073.22	477.92	461.00	18,056.30
05 704 0022	FOREIGN LANGUAGE	744.61	0.00	0.00	744.61
05 704 0023	CLASS OF 2029	378.20	0.00	0.00	378.20
05 704 0024	CLASS OF 2027	1,550.42	21.41	0.00	1,529.01
05 704 0025	SENIOR BANNERS	0.00	0.00	0.00	0.00
05 704 0026	NHS	4,187.36	277.00	313.00	4,223.36
05 704 0028	SCIENCE CLUB	653.43	0.00	0.00	653.43
05 704 0029	CLASS OF 2026	2,745.90	21.41	0.00	2,724.49
05 704 0030	CLASS OF 2028	1,025.35	0.00	0.00	1,025.35
05 704 0031	STUDENT COUNCIL	1,274.13	163.50	0.00	1,110.63
05 704 0032	VOCAL	1,179.55	0.00	0.00	1,179.55
05 704 0035	SKILLS USA	4,144.29	0.00	0.00	4,144.29
05 704 0036	BACKPACK PROGRAM	4,246.77	40.94	0.00	4,205.83
05 704 0037	GREENHOUSE	24,187.47	0.00	0.00	24,187.47
05 704 0038	COURTESY	1,443.02	0.00	0.00	1,443.02
05 704 0039	ELEMENTARY TEACHERS	2,006.70	260.43	0.00	1,746.27
05 704 0040	INDUSTRIAL ARTS STUDENT PROJ	(3,118.39)	105.16	100.50	(3,123.05)
05 704 0041	INVESTMENTS	23,083.21	0.00	80.63	23,163.84
05 704 0042	CLASS OF 2025	6,529.09	1,092.07	0.00	5,437.02
05 704 0043	LIBRARY	306.21	0.00	0.00	306.21
05 704 0044	SPEECH	186.60	0.00	0.00	186.60
05 704 0045	CLASS OF 2024	2,997.41	0.00	0.00	2,997.41
05 704 0046	SPECIAL PROJECTS	4,491.77	300.00	38.67	4,230.44
05 704 0047	ONE ACTS	1,304.95	0.00	0.00	1,304.95
05 704 0048	FPS LASER CREATIONS	160.82	0.00	0.00	160.82
05 704 0049	ACE, 40 DEV ASSETS	537.50	0.00	0.00	537.50
05 704 0051	QUIZ BOWL	906.02	(35.37)	25.00	966.39
05 704 0052	WEIGHTROOM PROJECT	5,591.31	0.00	0.00	5,591.31
05 704 0053	EHA WELLNESS PROGRAM	3,654.19	0.00	0.00	3,654.19
		<u>219,059.21</u>	<u>20,080.49</u>	<u>5,052.50</u>	<u>204,031.22</u>

06 -- LUNCH FUND

Statement Date: February 29, 2024

FPS Financial Software -- Account Balance

Checking Account Beginning of Month Balance on Hand: \$46,444.17

Cash Receipts:

Transfer from General Fund	\$0.00
Meal Sales	\$1,741.10
Federal Reimbursement	\$13,705.42
State Reimbursement	\$0.00
Contributions, Miscellaneous	\$1,500.00
Voided Checks	\$0.00
Interest	\$9.03

Expenses:

Prepaid Invoice Checks Written this Month	\$0.00
Invoice Checks Written this Month	-\$14,499.17
Payroll Employees	-\$5,461.97
Payroll Payees	-\$2,762.44

Checking Account End of Month Balance on Hand: \$40,676.14

Grand Total: \$40,676.14

Bank Statement -- Account Balance

Checking Account Balance this Statement: \$40,676.14

Cash Receipts Outstanding	\$0.00
Checks Outstanding	\$0.00

Checking Account End of Month Balance on Hand: \$40,676.14

Grand Total: \$40,676.14

08 -- BUILDING FUND

Statement Date: February 29, 2024

FPS Financial Software -- Account Balance

Checking Account Beginning of Month Balance on Hand:	\$564,428.42
Cash Receipts:	
Franklin County Treasurer	\$26,943.61
Harlan County Treasurer	\$543.25
Miscellaneous	\$0.00
Interest	\$115.52
Expenses:	
Invoice Checks Written this Month	\$0.00
Checking Account End of Month Balance on Hand:	\$592,030.80
Grand Total:	\$592,030.80

Bank Statement -- Account Balance

Checking Account Balance this Statement:	\$592,030.80
Cash Receipts Outstanding	\$0.00
Checks Outstanding	\$0.00
Checking Account End of Month Balance on Hand:	\$592,030.80
Grand Total:	\$592,030.80

Invoice Number	Description	Amount
11DW-CXPL-VRQD	CREDIT: STUDENT PROJ IGNITION KEY RETURN	(29.82)
1F3Y-QR6N-PXM3	YHEP GRANT:(4) HEADPHONE,(2) MICROPHONE	335.98
1F47-QQ43-Y79H	PROM DECOR	410.02
1MPP-CXTT-R3CJ	YHEP GRANT: ZOOM H5 PORTABLE RECORDER	218.99
1MR3-YYHR-4L7D	STUDENT PROJECT	34.82
1T6W-KF3M-N7HR	VB 6BALL BAG, (2) FLIP SCORE BOARDS	106.97
1W1Q-C669-HGJ9	(10) ELEM DICE BOARD BLOCK EDUC GAMES	242.48
1YHD-T4PQ-MY6Q	ROUND SELF-INK RUBBER STAMP PLANE LOGO	17.95
Vendor Name	AMAZON CAPITAL SERVICES	<u>1,337.39</u>
20240203SPEECH	ENTRY FEE: 2/3 (8) SPEECH ENTRIES	60.00
Vendor Name	AURORA HIGH SCHOOL	<u>60.00</u>
73412	PLAQ/MEDL/RBN: VARGLF,JVGLF,JHTRK,HSTRK	1,703.57
Vendor Name	AWARDS UNLIMITED INC.	<u>1,703.57</u>
20240208HSQBOWL	ENTRY FEE: 2/8 HS QUIZ BOWL @ BERTRAND	25.00
20240208JHQBOWL	ENTRY FEE: 2/8 JH QUIZ BOWL @ BERTRAND	25.00
Vendor Name	BERTRAND COMMUNITY SCHOOL	<u>50.00</u>
924821664	XC TRACK UNIFORMS: (60) TOPS, (60) BTMS	4,757.11
924839840	GOLF POLOS (4) MENS, (5) WOMENS	325.62
Vendor Name	BSN SPORTS, LLC	<u>5,082.73</u>
20240228FLYERBRANCH	GOOD BEHAVIOR INCENTIVE: FLYER BRANCH	270.00
Vendor Name	CASH ACTIVITIES	<u>270.00</u>
3517327	TL: (2) CASES COKE PRODUCTS	48.40
3517328	FCCLA: (4) CASES SUGAR FREE	72.00
3517329	CONCESSIONS: (6) CASES COKE PRODUCTS	145.20
3529949	FCCLA: (1) CASE SUGAR FREE	24.20
3529950	CONCESSIONS: (8) CASES COKE PRODUCTS	174.50
Vendor Name	CHESTERMAN COMPANY	<u>464.30</u>
3070512	DJ DOWNPAY: PROM HOSTED BY CLASS OF 2025	300.00
3070512A	DJ FINAL PAY: PROM HOSTED BY CLASS 2025	295.00
Vendor Name	COMPLETE WEDDING + EVENTS	<u>595.00</u>
20240205DATING	TSHIRTS: (64) DATING VIOLENCE NHS FCCLA	554.00
20240216STDTOUNCIL	TSHIRTS: (17) STUDENT COUNCIL	163.50
Vendor Name	CONNIE'S CREATIONS	<u>717.50</u>
6721	STD PROJ:(25) 1/2 ROD,(16)1x1,(2) 2x2	66.50
Vendor Name	DUNCAN'S WELDING	<u>66.50</u>
4472a	1/6 FHS WRESTLING INVITE BRACKET PRINTS	111.48
Vendor Name	ESU 11	<u>111.48</u>
20240208VARGBBB	OFFICIAL: 2/8 VAR GBBB vs ELBA	150.00
Vendor Name	EVERITT, MARSHALL	<u>150.00</u>
20240208FFACOATDRIVE	FFA COAT DRIVE: 2/8 GBBB ADMISSION (8)	48.00
Vendor Name	FRANKLIN PUBLIC SCHOOLS ACTIVITIES FUND	<u>48.00</u>

Invoice Number	Description	Amount
20240223PIZZA	FFA: (10) PIZZAS	215.00
Vendor Name	FROSTY MUG	<u>215.00</u>
2692	FFA PETTING ZOO (8) COARSE WOOD SHAVINGS	112.00
Vendor Name	GERDES FEED & SUPPLY LLC	<u>112.00</u>
20240222JHGWRINVITE	ENTRY FEE: 2/22 JH GWR GIBBON INVITE	25.00
Vendor Name	Gibbon Public School	<u>25.00</u>
20240221TVCSPEECH	JUDGE: 2/21 TVC SPEECH @ FPS	140.50
Vendor Name	GLANZER, BROOKS	<u>140.50</u>
20240224SPEECH	ENTRY FEE: 2/24 (15) SPEECH ENTRIES	112.50
Vendor Name	HOLDREGE PUBLIC SCHOOLS	<u>112.50</u>
20240209	DATING VIOLENCE AWARENESS PRESENTATION	300.00
Vendor Name	JANAS CAMPAIGN INC	<u>300.00</u>
20240221TVCSPEECH	JUDGE: 2/21 TVC SPEECH @ FPS	163.00
Vendor Name	JSSJ, LLC	<u>163.00</u>
20240217SUTTONSPEECH	JUDGE: 2/17 SUTTON SPEECH INVITE	75.00
Vendor Name	KAHRS, MAKAYLIN	<u>75.00</u>
20240221TVCSPEECH	JUDGE: 2/21 TVC SPEECH @ FPS	135.00
Vendor Name	KOONTZ, JO ANN	<u>135.00</u>
20240208VARGBBB	OFFICIAL: 2/8 VAR GBBB vs ELBA	150.00
Vendor Name	KOUPAL, KEITH	<u>150.00</u>
20240221TVCSPEECH	JUDGE: 2/21 TVC SPEECH @ FPS	291.50
Vendor Name	LECHER, ASHLEY	<u>291.50</u>
20240221TVCSPEECH	JUDGE: 2/21 TVC SPEECH @ FPS	185.50
Vendor Name	MARGRITZ, KELI	<u>185.50</u>
20240210SPEECH	ENTRY FEE: 2/10 SPEECH (11) ENTRIES	82.50
Vendor Name	MINDEN PUBLIC SCHOOL	<u>82.50</u>
20240221DISTCDE	FALL CDE CONTEST: (1) WELDING TEAM	30.00
Vendor Name	NAEA DIST 6	<u>30.00</u>
20240212	ADMISSION: 2/12 GBB SUBDISTRICTS CHEER	20.00
20240212GBBSUBDIST	STREAMING FEE: 2/12 GBB SUB DISTRICTS	50.00
V*20240212	ADMISSION: 2/12 GBB SUBDISTRICTS CHEER	(20.00)
Vendor Name	OVERTON PUBLIC SCHOOLS	<u>50.00</u>
20240208	(20) CONCESSIONS PIZZA	223.99
Vendor Name	PIZZA HUT	<u>223.99</u>
3367	LODGING: (1) ROOM BOYS WR DISTR @ SHELBY	129.95
3368	LODGING: (1) ROOM BOYS WR DISTR @ SHELBY	129.95

Invoice Number	Description	Amount
3369	LODGING: (1) ROOM BOYS WR DISTR @ SHELBY	129.95
3370	LODGING: (1) ROOM BOYS WR DISTR @ SHELBY	129.95
Vendor Name	RAMADA BY WYNDHAM COLUMBUS HOTEL & CONFERENCE CENTER	519.80
20240127GBWRINVITE	ENTRY FEE: 1/27 GBWR WARCAT INVITE	170.00
Vendor Name	RED CLOUD COMMUNITY SCHOOLS	170.00
20240201-376AF	MONTHLY TRANSACTIONS	1,786.27
Vendor Name	RIGHTWAY GROCERY	1,786.27
20240221TVCSPEECH	JUDGE: 2/21 TVC SPEECH @ FPS	156.50
Vendor Name	RODEHORST, SHANNON	156.50
70912060	LODGING: (1) ROOM WR @ NELIGH	89.99
70912061	LODGING: (1) ROOM WR @ NELIGH	89.99
70912966	LODGING: (1) ROOM WR @ NELIGH	89.99
70912993	LODGING: (1) ROOM WR @ NELIGH	80.99
70912994	LODGING: (1) ROOM WR @ NELIGH	89.99
70912995	LODGING: (1) ROOM WR @ NELIGH	89.99
70913020	LODGING: (1) ROOM WR @ NELIGH	89.99
Vendor Name	RODEWAY INN AND SUITES	620.93
S30870	STD PROJ: (4) 8' COM, (2) WOOD PUTTY	33.66
Vendor Name	S.E. SMITH & SONS	33.66
20240221TVCSPEECH	JUDGE: 2/21 TVC SPEECH @ FPS	131.50
Vendor Name	SCHMIDT, ALYSSA	131.50
20240221TVCSPEECH	JUDGE: 2/21 TVC SPEECH @ FPS	145.50
Vendor Name	SKILES, GAVIN	145.50
000008	TVC SPEECH HOSP RM: (6) DZ CINNAMON ROLL	168.00
Vendor Name	SMILEY SWEET CAKES	168.00
20240221TVCSPEECH	JUDGE: 2/21 TVC SPEECH @ FPS	190.50
Vendor Name	STUMP, ANGELA	190.50
20240217SPEECH	ENTRY FEE: 2/17 (12) SPEECH ENTRIES	104.00
Vendor Name	SUTTON PUBLIC SCHOOL	104.00
561461955	CREDIT MEMO: (1) CS QUAKER GRANOLA BARS	(35.37)
561465997A	CONCESSIONS: (2) CS PRETZELS	99.98
Vendor Name	SYSCO LINCOLN	64.61
20240221TVCSPEECH	JUDGE: 2/21 TVC SPEECH @ FPS	160.50
Vendor Name	THAYER, ASHLEY	160.50
33081	LODGING: ST WRESTLING (6) ROOMS	2,322.00
Vendor Name	TRU BY HILTON - OMAHA	2,322.00
20240125STMT-AF	MONTHLY TRANSACTIONS	408.76
Vendor Name	US BANK	408.76

Franklin Public School
03/06/2024 07:19 AM

Board Report - For Board

FEBRUARY ACTIVITY FUND CHECKS PRINTED

Page: 4

User ID: HERMARC

Invoice Number	Description	Amount
20240208VARGBBB	OFFICIAL: 2/8 VAR GBBB vs ELBA	150.00
Vendor Name	WARDYN, TODD	<hr/> 150.00
Fund Number	05	<hr/> 20,080.49
Checking Account ID	5	<hr/> 20,080.49

FRANKLIN PUBLIC SCHOOLS
MONTHLY CREDIT CARD TRANSACTIONS

FUND	COMPANY	TRANSACTION DESCRIPTION	AMOUNT
------	---------	-------------------------	--------

GF	CASEYS	FLYER CUP INCENTIVE PIZZA: C STRATMAN	\$91.98
GF	UNL MARKETPLACE	SPANISH LANGUAGE FAIR: B CLEVELAND	\$75.00
			\$166.98

AF	ALLIANZ/NSAA	STATE WRESTLING GATE ADMISSION: C LECHER	\$95.10
AF	MECA PARKING	STATE WRESTLING PARKING FEE: C LECHER	\$10.00
AF	RAISING CANES	DISTRICT WRESTLING MEAL: C STRATMAN	\$17.45
AF	DOLLAR TREE	PROM GLASSWARE: H BOETTCHER	\$105.00
AF	SUMMIT RACING	STUDENT PROJECT ITEM: H HILL	\$79.93
AF	WALMART	STATE WRESTLING COOLER MEAL: B LEWIS	\$46.95
AF	JIMMY JOHNS	STATE WRESTLING MEAL: B LEWIS	\$139.18
AF	PEPPERJAX GRILL	STATE WRESTLING MEAL: B LEWIS	\$26.96
AF	HUHOT	STATE WRESTLING MEAL: B LEWIS	\$147.40
			\$667.97

FEBRUARY 26, 2024 STATEMENT TOTAL PAID

\$834.95

Invoice Number	Description	Amount
1F1J-NTGD-GCRL	CTE: STORG,SQ,SNDPAPR,BROOM,MEAS TPE,VAC	301.17
1GV4-4FFR-F9H9	32GB SD CARD	11.69
1NW7-YRPT-Q34W	(72) PK C BATTERY, 50LB LAUNDRY DETERGNT	120.95
1NW7-YRPT-WR4V	(30) HEADPHONES	39.99
1WKC-YKV1-D4KY	(4) RDR6 RECESSED CAN LIGHT	65.45
1Y74-L4GJ-31GG	HARMONIC BALANCER PULLEY	43.64
Vendor Name	AMAZON CAPITAL SERVICES	582.89
C-24608-JW	GROUNDS MAINT FERT/SEED	2,241.59
Vendor Name	ARROW SEED COMPANY	2,241.59
170873055191	(1026) GAL RUBY CLR,(375) GAL #1 CLR DSL	4,993.14
Vendor Name	AURORA COOPERATIVE	4,993.14
20240301GH	NATURAL GAS - GREENHOUSE FEBRUARY	449.36
20240301MB	NATURAL GAS - MAIN BUILDING FEBRUARY	2,649.58
20240301SB	NATURAL GAS - SHOP BUILDING FEBRUARY	273.09
Vendor Name	BLACK HILLS ENERGY	3,372.03
1045	INFRARED SCAN OF ELECTRICAL SYSTEM	500.00
Vendor Name	BLUEWAVE INFRARED SCANNING LLC	500.00
20240229	UTILITIES: JANUARY 15 - FEBRUARY 15	5,850.01
Vendor Name	CITY OF FRANKLIN	5,850.01
1028683	BUS #16:CALIPER, HUB ASMBLY,ROTOR,BRAKE	3,609.34
Vendor Name	DORN AUTOMOTIVE, LLC	3,609.34
24-4694	(6) SCHOOL HOUSE BULLIES TRAINING	1,495.00
Vendor Name	EDU-SAFE LLC	1,495.00
2324-2-8	2023-24 SPED 2ND QUARTER,MISC IN-SERVICE	122,816.26
4484	2ND QUARTER INSERVICE, KSB HOT TOPICS	848.99
Vendor Name	ESU 11	123,665.25
3322	PROFESSIONAL SERVICES PT SPED	585.00
3339	PROFESSIONAL SERVICES PT SPED	240.00
Vendor Name	FAMILY PT & SPORTS	825.00
5776-261226	BUSES: HYD LUBE	32.30
5776-261264	BUSES: HYD LUBE, OIL FILTER	93.27
5776-261753	BUSES: CIRCUIT BREAKER	6.47
5776-261799	BUSES / VANS: WINDSHIELD WIPER FLUID	35.88
5776-261829	BUSES: FUEL FILTER	75.51
Vendor Name	FRANKLIN AUTO PARTS	243.43
20240229	02.28.2023-03.27.2024 TELECOMM SERVICE	835.35
Vendor Name	FRONTIER	835.35
2024APRIL#44	COPIER LEASE APRIL PAYMENT #044	1,582.01
Vendor Name	HOMETOWN LEASING	1,582.01
655701	SIGMA ID3 PRINTER, (2) PRINTER RIBBONS	1,934.36

Invoice Number	Description	Amount
Vendor Name	IDENTISYS INCORPORATED	1,934.36
311839	WELD/WOOD CLASS: DRILL BITS, APRON, COAT	318.92
Vendor Name	ISLAND SUPPLY WELDING COMPANY	318.92
366230176	BAND: TVC HONOR BAND SHEET MUSIC EPRINT	210.00
Vendor Name	JW PEPPER & SON INC.	210.00
15858	LEGAL SERVICES FEBRUARY	720.00
Vendor Name	KSB SCHOOL LAW, PC LLO	720.00
805610	WELDING CLASS: (6) 1.25x1.25x11GA SQ TBE	22.65
Vendor Name	KULLY PIPE & STEEL	22.65
11654870	2020 JD E180 MOWER: REPAIR LOOSE STEER	1,764.38
Vendor Name	LANDMARK IMPLEMENT, INC	1,764.38
20240311CELLREIMB	SUPERINTENDENT CELL PHONE REIMB	89.92
Vendor Name	LECHER, CHRISTOPHER	89.92
14346	RENEWAL 6/19/2024-6/18/2025	495.00
Vendor Name	LIBRARY WORLD, INC	495.00
52309548	WELDING SUPPLIES: CYLINDER RENTAL	64.40
Vendor Name	MATHESON TRI-GAS, INC	64.40
2474325	MOSYLE MNGR RENEWAL 3/20/2024-3/20/2025	1,980.00
Vendor Name	MOSYLE CORPORATION	1,980.00
PA-49915	CAMERA BLACK/WHITE WASH APPEARANCE	157.33
Vendor Name	NEX-TECH COMMUNICATIONS LLC	157.33
868614	FSA PARTICIPANT MONTHLY FEE FEB 1-29	40.00
Vendor Name	OMNIFY	40.00
2022149151	(4) BACKGROUND CHECKS	113.00
Vendor Name	ONE SOURCE THE BACKGROUND COMPANY	113.00
27393	(7) QUARTERLY VAN INSPECTIONS	168.00
Vendor Name	PAULSEN AUTOMOTIVE	168.00
L231362	(2) GLV NIPPLE, (2) GAS FTG FLARE	19.16
L231399	GROUNDS: PVC PLUG	1.69
Vendor Name	PLANK LUMBER & HARDWARE	20.85
58219815	INSECT CONTROL ONLY MAINTENANCE	108.62
Vendor Name	PRESTO-X	108.62
Q1234271	LEASE POSTAGE MACHINE: APR 7 - JUL 6	240.00
Vendor Name	QUADIENT LEASING USA, INC	240.00
SRV109345	COMBED OUT COILS ON 9 DUCTLESS UNITS	2,854.00

Invoice Number	Description	Amount
SRV110099	LIBR RM,RM 108,RM 305:CONDNS LINES,DAMPR	2,133.61
Vendor Name	RASMUSSEN MECHANICAL SERVICES	4,987.61
INV5319364	EDUCLIMBER SOFTWARE LICENSE RENEWAL	1,945.35
Vendor Name	RENAISSANCE LEARNING, INC	1,945.35
20240301-376GF	MONTHLY TRANSACTIONS	1,418.54
Vendor Name	RIGHTWAY GROCERY	1,418.54
S30978	GROUNDS: ROPE, INSULATORS	106.89
Vendor Name	S.E. SMITH & SONS	106.89
4027117185	ESSER III: CHEMISTRY CURRICULUM TE	255.42
7028680605	ESSER III: CHEMISTRY CURRICULUM	4,860.00
Vendor Name	SAVVAS LEARNING COMPANY LLC	5,115.42
M74816323	K-5 SCHOLASTIC NEWS, JH SCIENCE WORLD	1,012.61
Vendor Name	SCHOLASTIC INC.	1,012.61
20240306	STAFF APPRECIATION:MUFFIN,BROWNIE,BLONDI	96.00
Vendor Name	SOLAAS, RYAN	96.00
13364	RANDOM SUBSTANCE ABUSE PANEL TESTING	553.00
Vendor Name	SPORT SAFE TESTING SERVICE, INC	553.00
20240227	(17) HP CHROMEBOOKS, (16) GOOGLE MANAGE	6,232.31
Vendor Name	STAPLES TECHNOLOGY SOLUTIONS	6,232.31
8073523363	CULINARY NAPKINS, ZIPLOCS	86.75
Vendor Name	STAPLES, INC.	86.75
2024FEBRUARY	NETWORK NEBRASKA: FEBRUARY	267.63
Vendor Name	STATE OF NEBRASKA	267.63
20240311CELLREIMB	JHHS PRINCIPAL CELL PHONE REIMB	90.65
20240311MILEREIMB	MILEAGE REIMB: 8/18-2/12 ACTIVITY EVENTS	2,548.88
Vendor Name	STRATMAN, CHRISTINE	2,639.53
IN2024020047	(41) GOOGLE WRKSPC BACKUP 3/1/24-2/29/25	393.60
Vendor Name	SYSCLOUD INC	393.60
257767963	LEAP DAY, LEAP YR, DIGITAL WORD BUILDING	13.00
259479041	BUILD IT UP BUNDLE	16.00
Vendor Name	TEACHER SYNERGY LLC	29.00
304757	TIME MANAGEMENT SYSTEM: MONTHLY	114.50
Vendor Name	TIME MANAGEMENT SYSTEMS, INC	114.50
20240226STMT-GF	MONTHLY TRANSACTIONS	166.98
Vendor Name	US BANK	166.98
9957475514	JAN 24 - FEB 23, 2024 SERVICES	154.88
Vendor Name	VERIZON WIRELESS	154.88

Invoice Number	Description	Amount
95584191	MONTHLY FUEL	976.23
Vendor Name	WEX BANK	976.23
Fund Number 01		184,539.30
Checking Account ID 1		184,539.30
1RDL-HQHV-3FC1	BARCODE SCANNER FOR LUNCH BADGES	34.98
Vendor Name	AMAZON CAPITAL SERVICES	34.98
14114143	MEAL ITEMS AND SUPPLIES	662.11
14122188	MEAL ITEMS AND SUPPLIES	901.96
CM3571673	CREDIT: (2) BROCCOLI FLORET FRESH	(15.62)
Vendor Name	CASH-WA DISTRIBUTING CO. OF KEARNEY, INC.	1,548.45
6013	WORDWARE LUNCH SYSTEM LICENSE RENEWAL	1,957.14
Vendor Name	EDUTRAK, LLC	1,957.14
17625	REPLACED HEAT TAPE ON FREEZER DRAIN	447.50
Vendor Name	HEARTLAND REFRIGERATION LLC	447.50
1114661	(1000) MILKS	413.36
1114751	(500) MILKS	209.04
1114808	(800) MILKS	332.65
1114895	(1300) MILKS	536.48
1114970	(477) MILKS	211.13
Vendor Name	HILAND DAIRY FOODS COMPANY LLC	1,702.66
20240221	(76) LBS BEEF PATTIES,(166) LBS GRD BEEF	1,390.10
Vendor Name	KENSINGTON LOCKER	1,390.10
20240301-376LF	MEAL ITEMS	149.68
Vendor Name	RIGHTWAY GROCERY	149.68
561492749	MEAL ITEMS	704.03
561504611	MEAL ITEMS AND SUPPLIES	1,243.88
561531478a	MEAL ITEMS AND SUPPLIES	1,743.30
Vendor Name	SYSCO LINCOLN	3,691.21
5665860	MEAL ITEMS AND SUPPLIES	1,243.14
5665862	MEAL ITEMS	116.58
Vendor Name	US FOODS	1,359.72
Fund Number 06		12,281.44
Checking Account ID 6		12,281.44

Invoice Number	Description	Amount
INV536144	SCRUB MACH: RECOVERY TANK DRAIN HOSE	162.86
Vendor Name	EAKES INC.	<u>162.86</u>
INV-09079	PROFESSIONAL SERVICES (OT) SPED	4,493.28
Vendor Name	INSPIRE REHABILITATION HARLAN COUNTY, LLC	<u>4,493.28</u>
208133808095	FUN STICKERS,PENCILS, FELT PENS	83.99
Vendor Name	SCHOOL SPECIALTY, LLC	<u>83.99</u>
20240307	*A10315 TRUCK: BALANCE,ROTATE,ALIGN	160.00
Vendor Name	SWEET'S GARAGE	<u>160.00</u>
191044	LODGING: STATE SPELLING BEE K BISLOW	155.71
Vendor Name	TRU BY HILTON - OMAHA	<u>155.71</u>
Fund Number	01	<u>5,055.84</u>
Checking Account ID	1	5,055.84
14129636	MEAL ITEMS AND SUPPLIES	744.51
Vendor Name	CASH-WA DISTRIBUTING CO. OF KEARNEY, INC.	<u>744.51</u>
1115061	(500) MILKS	207.43
1115120	(995) MILKS	414.37
Vendor Name	HILAND DAIRY FOODS COMPANY LLC	<u>621.80</u>
Fund Number	06	<u>1,366.31</u>
Checking Account ID	6	1,366.31

February 13, 2024

Franklin Public Schools
1001 M St.
Franklin, NE 68939

Dear Franklin School Board,

Please accept my formal resignation from my position from K-12 Vocal Music Teacher at Franklin, effective at the end of the 2023-2024 school year.

I have enjoyed my time at Franklin Public Schools. I had the privilege to work with wonderful colleagues who supported and taught me many things I will take with me. I have enjoyed working with the students of Franklin and I look forward to their continued success and growth.

Sincerely,

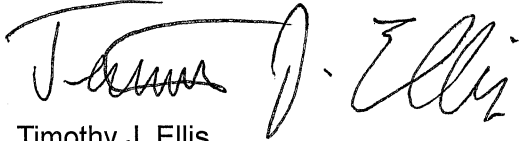
A handwritten signature in black ink that reads "Timothy J. Ellis". The signature is written in a cursive style with a large, sweeping initial "T" and a distinct "J" and "E".

Timothy J. Ellis

Shay Baumgart
506 11th Ave
Franklin, NE 68939
shayspady@gmail.com
4029844773
03/04/2024

Mrs. Shelley Kahrs
Franklin Elementary School
1001 M Street
Franklin, NE 68939

Dear Mrs. Shelley Kahrs,

I am writing to formally resign from my position as 5th grade teacher at Franklin Elementary. This decision has not been easy, and it comes after careful consideration and reflection on my family's needs.

I have thoroughly enjoyed my time at Franklin Elementary, and I am grateful for the opportunities for personal and professional development that the school has provided me. I have had the privilege of working with dedicated colleagues, supportive parents, and, most importantly, wonderful students. The experiences and memories from my time here will always hold a special place in my heart.

However, after much contemplation, I have decided to pursue a new path in my career. This decision is not a reflection of any dissatisfaction with Franklin but rather a step toward continuing my growth as a teacher closer to my immediate family.

I will ensure a smooth transition by completing any outstanding tasks and providing necessary documentation before my departure. I am more than willing to collaborate with my successor and offer assistance during this transitional period.

I want to express my gratitude to you, the school administration, and my colleagues for the support, and encouragement I have experienced during my tenure at Franklin. I wish the school, the staff, and the students continued success in the future.

Thank you again for the experiences and memories.

Sincerely,

Shay Baumgart

Daktronics Shot Clocks

We have two options for shot clocks without having to replace our scoreboard.

Option 1: (2) BB-2115 with radios, start/stop/reset switch-\$4575

Option 2: (2) BB-2114 with radios, start/stop/reset switch-\$3500

With both options we will need end of quarter light kits:

42"-\$2050 for 2

Prices with current information.

1 gym with BB-2115 and end of quarter light kit = \$6,625*^

1 gym with BB-2114 and end of quarter light kit + \$5,550*^

2 gyms with BB-2115 and end of quarter light kit = \$13,250*^

2 gyms with BB-2114 and end of quarter light kit = \$11,100*^

* Freight is not calculated until order is placed.

^ Installation cost not included, all installation quotes have not been returned.

DAKTRONICS BB-2114 PRODUCT SPECIFICATIONS



This indoor single-sided LED basketball shot clock timer displays shot times up to a value of 99 seconds. It can also count down from any preset time between 0 and 99 seconds. A hand-held start/stop/reset switch is included with purchase.

POWER (120 VAC)*	UNCRATED WEIGHT	DIMENSIONS
30 Watts, 0.3 Amp	15 lb (7 kg)	1'-7" H x 1'-10" W x 6" D (483 mm x 559 mm x 152 mm)

**Models with 240 VAC power at half the indicated amperage are also offered (International Use Only).*

DIGITS

- All digits are 13" (330 mm) high.
- All digits are red.
- Timer features PanaView® LED digit technology.

DISPLAY COLOR

Semi-gloss black

CONSTRUCTION

Durable, lightweight aluminum Tuff Sport® cabinet withstands high-velocity impact from air-filled sports balls without the need for protective screens.

PRODUCT SAFETY APPROVAL

ETL-listed, tested to CSA standards, and CE-labeled **for indoor use only**

OPERATING TEMPERATURES

- Display: -22° to 122° Fahrenheit (-30° to 50° Celsius)
- Console: 32° to 130° Fahrenheit (0° to 54° Celsius)

WWW.DAKTRONICS.COM E-MAIL: SALES@DAKTRONICS.COM

201 Daktronics Drive, PO Box 5128, Brookings, SD 57006
Phone: 1-800-325-8766 or 605-692-0200 Fax: 605-697-4746
DD2481873 020724 Page 1 of 4



DAKTRONICS BB-2114 PRODUCT SPECIFICATIONS

CONTROL CONSOLE*	CONTROL OPTIONS
All Sport 5000 (see SL-03991)	Wireless: 2.4 GHz spread spectrum radio features 64 non-interfering channels and 8 broadcast groups (see SL-04370). This is a popular upgrade.
OR	
All Sport® 1600** (see SL-04352)	Wired: One-pair shielded cable of 22 AWG minimum is required. A cover plate with mounted connector and standard 2" x 4" x 2" (51 mm x 102 mm x 51 mm) outlet box is provided. Connector mates with signal cable from control console.

* Controller not included with standard purchase; timer(s) are typically controlled by the same console controlling the basketball scoreboard(s).
** Controller is for standalone timing operation only; email SALES@DAKTRONICS.COM for more information.

LIGHT STRIP OUTPUTS

Timer features outputs to control Daktronics end-of-period backboard LED light strips (sold separately).

HORN

An internal horn sounds automatically when shot clock counts down to zero with a sound that is distinctly different from that of the game-clock horn.

GENERAL INFORMATION

Timer provides shot clock timing capabilities. 100% solid state electronics are housed in an all aluminum cabinet. Timer arrives at the site fully assembled. Mounting hardware not included. Specifications and pricing are subject to change without notice.

OPTIONS & ACCESSORIES

- Red end-of-period backboard light strips (see [DD4703928](#))
- Amber shot clock violation backboard light strip control
- Protective screen (see [SL-02551](#))
- Carrying handle
- Visual horn indicator (see [SL-05489](#))

FOR ADDITIONAL INFORMATION

- Mechanical Specifications: DWG-5052521 (attached)
- Component Locations: DWG-5052522 (attached)
- Architectural Specifications: See [SL-04794](#)
- Installation Manual: See [DD2481645](#)
- Service Manual: See [DD2481648](#)
- Installation Quick guide: See [DD5071871](#)

NOTES:

1. MOUNTING HARDWARE IS NOT PROVIDED.
2. SEE DRAWING A-91230 FOR SUGGESTIONS ON MOUNTING TO CEILING-SUSPENDED BACKSTOPS.
3. FOR PORTABLE BACKSTOPS, CONTACT THE BACKSTOP MANUFACTURER FOR MOUNTING HARDWARE.

BB-2114

WEIGHTS	
SHIPPING WEIGHT	MOUNTING WEIGHT
20 LBS (10 KG)	15 LBS (7 KG)

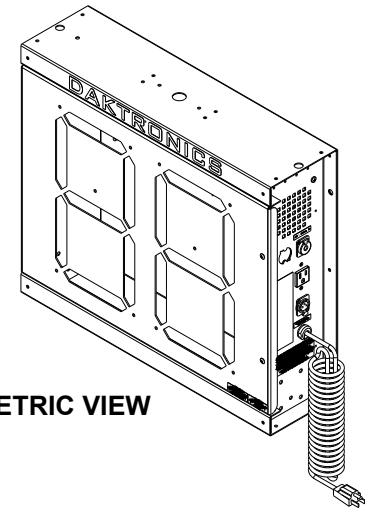

ISOMETRIC VIEW

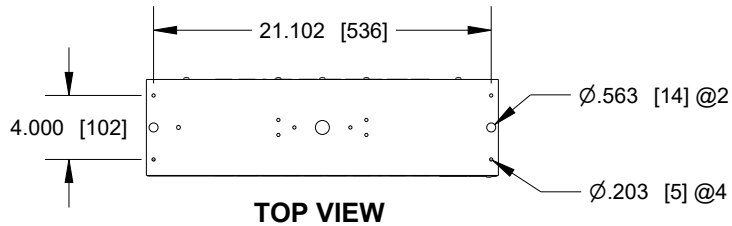

TOP VIEW

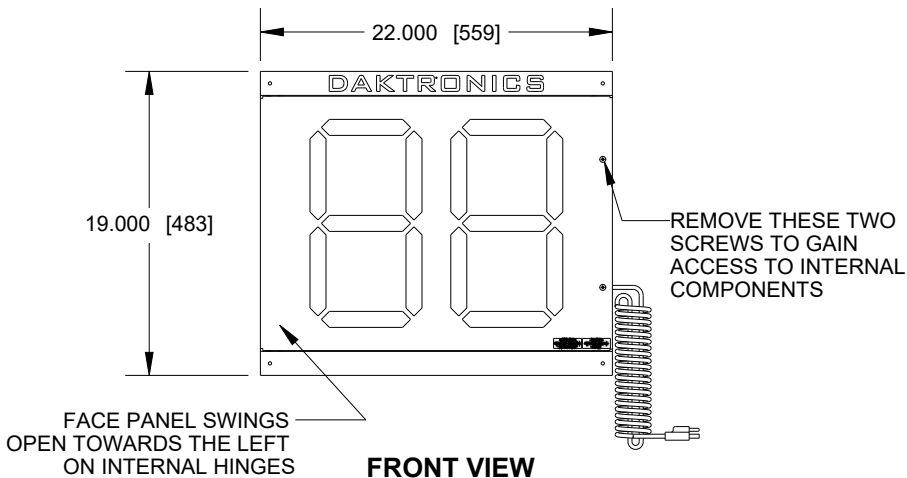

FRONT VIEW

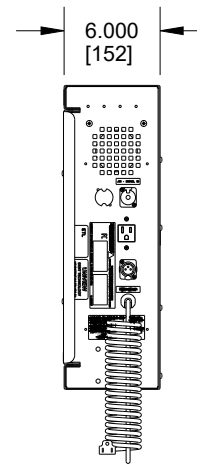

SIDE VIEW

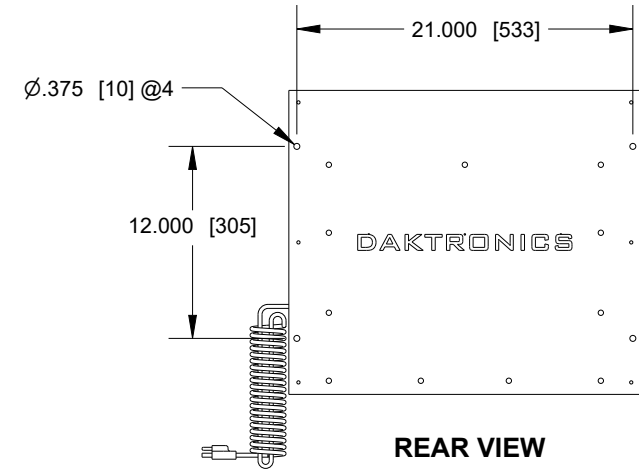

REAR VIEW

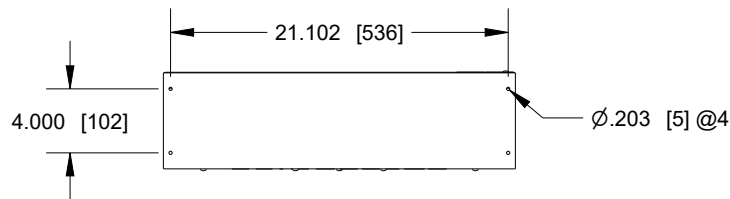

BOTTOM VIEW

TUFF SPORT® IS A COPYRIGHT OF DAKTRONICS

REV:	DATE:	DESCRIPTION:	BY:
		THE CONCEPTS EXPRESSED AND DETAILS SHOWN ON THIS DRAWING ARE CONFIDENTIAL AND PROPRIETARY. DO NOT REPRODUCE BY ANY MEANS WITHOUT THE EXPRESS WRITTEN CONSENT OF DAKTRONICS, INC. OR ITS WHOLLY OWNED SUBSIDIARIES. COPYRIGHT 2022 DAKTRONICS, INC. (USA)	
PROJECT: TUFF SPORT® SCOREBOARDS			
TITLE: MECHANICAL SPEC; BB-2114			
DATE: 11-MAY-22	DIM UNITS: INCHES [MILLIMETERS]	SHEET	REV
SCALE: 1/12	DO NOT SCALE DRAWING		00
DESIGN: NWINTER	JOB NO.	FUNC - TYPE - SIZE	5052521
DRAWN: NWINTER	P1237	E - 07 - A	

DIGIT, SIGNAL AND POWER SPECIFICATIONS:

BB-2114

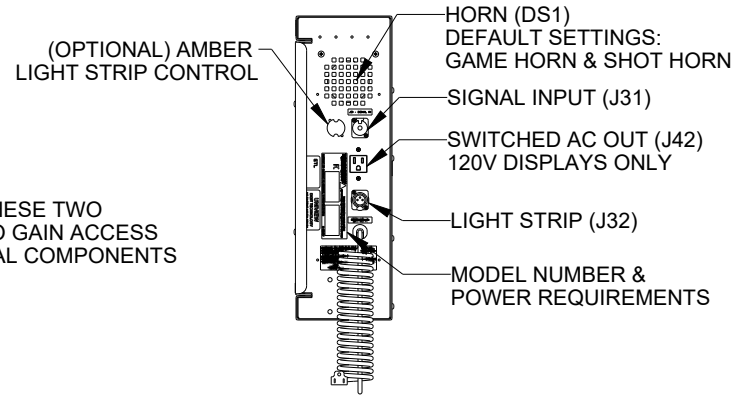
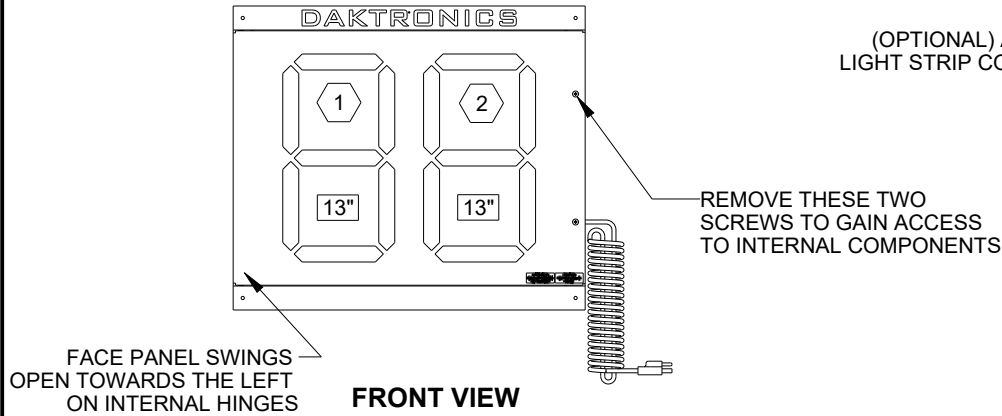

SIDE VIEW

LEGEND:

- = DIGIT DESIGNATION IN RELATION TO DRIVER
- = DIGIT SIZE
- = SEGMENT DESIGNATION
- = DRIVER NUMBER

COMPONENT LOCATIONS:

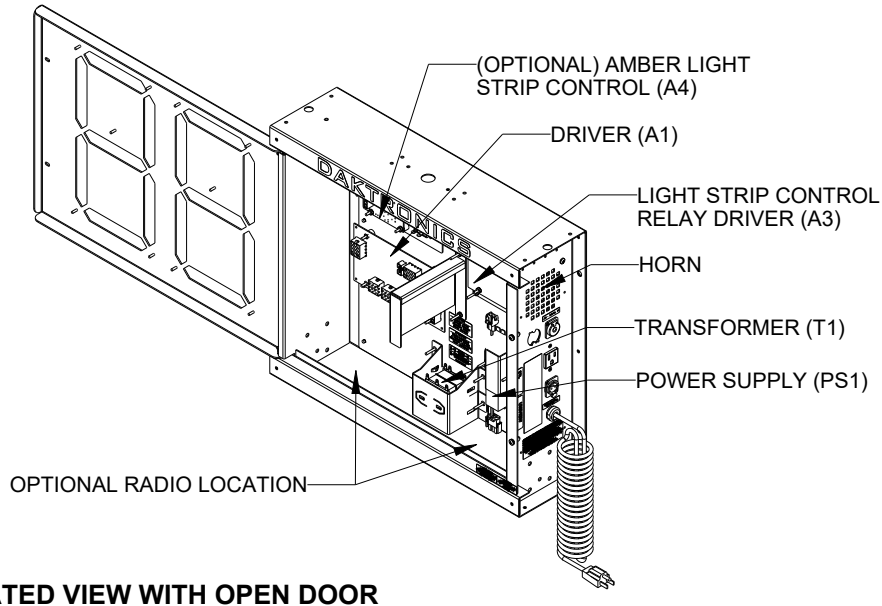

NOTES:

1. A3 BOARD CAPABILITIES ARE GAME HORN, SHOT HORN, CLK = STOP, CLK = 0. J32/J42 (TOGETHER), & HORN CAN BE SET TO DIFFERENT VALUES IF REQUIRED.

2. TO CHANGE DEFAULT FUNCTION OF HORN, ENABLE OTHER SEGMENTS, OR CHANGE LIGHT STRIP OPTIONS, REFER TO DWG A-179151. TUFF SPORT® IS A COPYRIGHT OF DAKTRONICS

REV: 01	DATE: 02 MAR 23	DESCRIPTION: PER CN-155736, CHANGED LIGHT STRIP CONTROL, OUTLET, AND SWITCHED OUTLET FROM OPTIONAL TO INCLUDED	BY: DRO 04920
		THE CONCEPTS EXPRESSED AND DETAILS SHOWN ON THIS DRAWING ARE CONFIDENTIAL AND PROPRIETARY. DO NOT REPRODUCE BY ANY MEANS WITHOUT THE EXPRESS WRITTEN CONSENT OF DAKTRONICS, INC. OR ITS WHOLLY OWNED SUBSIDIARIES. COPYRIGHT 2022 DAKTRONICS, INC. (USA)	
PROJECT: TUFF SPORT® SCOREBOARDS			
TITLE: COMPONENT LOCATION; BB-2114			
DATE: 02-MAR-23	DIM UNITS: INCHES [MILLIMETERS]	SHEET	REV 01
SCALE: 1/12	DO NOT SCALE DRAWING		
DESIGN: NWINTER	JOB NO. P1237	FUNC - TYPE - SIZE E - 07 - A	5052522
DRAWN: NWINTER			

DAKTRONICS BB-2115 PRODUCT SPECIFICATIONS



This indoor single-sided LED basketball game clock and shot clock timer displays game time to 99:59 and shot times up to a value of 99 seconds. It can also count down from any preset time between 0 and 99 seconds. During the last minute of the period, game time is displayed to 1/10 of a second. A hand-held start/stop/reset switch is included with purchase.

POWER (120 VAC)*	UNCRATED WEIGHT	DIMENSIONS
50 Watts, 0.5 Amp	30 lb (14 kg)	2'-4" H x 2'-5" W x 6" D (711 mm x 737 mm x 152 mm)

**Models with 240 VAC power at half the indicated amperage are also offered (International Use Only).*

DIGITS

- Game clock digits are 7" (178 mm) high. Shot clock digits are 13" (330 mm) high.
- Game clock digits are amber. Shot clock digits are red.
- Timer features PanaView® LED digit technology.

DISPLAY COLOR

Choose a color from the Daktronics standard paint book (see [SL-02730](#)).

CONSTRUCTION

Durable, lightweight aluminum Tuff Sport® cabinet withstands high-velocity impact from air-filled sports balls without the need for protective screens.

PRODUCT SAFETY APPROVAL

ETL-listed, tested to CSA standards, and CE-labeled **for indoor use only**

OPERATING TEMPERATURES

- Display: -22° to 122° Fahrenheit (-30° to 50° Celsius)
- Console: 32° to 130° Fahrenheit (0° to 54° Celsius)

WWW.DAKTRONICS.COM E-MAIL: SALES@DAKTRONICS.COM

201 Daktronics Drive, PO Box 5128, Brookings, SD 57006
Phone: 1-800-325-8766 or 605-692-0200 Fax: 605-697-4746
DD2481875 020724 Page 1 of 4



DAKTRONICS BB-2115 PRODUCT SPECIFICATIONS

CONTROL CONSOLE	CONTROL OPTIONS
All Sport® 5000* (see SL-03991)	Wireless: 2.4 GHz spread spectrum radio features 64 non-interfering channels and 8 broadcast groups (see SL-04370). This is a popular upgrade. Wired: One-pair shielded cable of 22 AWG minimum is required. A cover plate with mounted connector and standard 2" x 4" x 2" (51 mm x 102 mm x 51 mm) outlet box is provided. Connector mates with signal cable from control console.

* Controller not included with standard purchase; timer(s) are typically controlled by the same console controlling the basketball scoreboard(s).

LIGHT STRIP OUTPUTS

Timer features outputs to control Daktronics end-of-period backboard LED light strips (sold separately).

HORN

An internal horn sounds automatically when shot clock counts down to zero with a sound that is distinctly different from that of the game-clock horn.

GENERAL INFORMATION

Timer provides game and shot clock timing capabilities. 100% solid state electronics are housed in an all aluminum cabinet. Timer arrives at the site fully assembled. Mounting hardware not included. Specifications and pricing are subject to change without notice.

OPTIONS & ACCESSORIES

- Red end-of-period backboard light strips (see [DD4703928](#))
- Amber shot clock violation backboard light strip control
- Protective screen (see [SL-02551](#))
- Carrying handle
- Visual horn indicator (see [SL-05489](#))

FOR ADDITIONAL INFORMATION

- Mechanical Specifications: DWG-5052523 (attached)
- Component Locations: DWG-5052524 (attached)
- Architectural Specifications: See [SL-04795](#)
- Installation Manual: See [DD2481645](#)
- Service Manual: See [DD2481648](#)
- Installation Quick guide: See [DD5071871](#)

NOTES:

1. MOUNTING HARDWARE IS NOT PROVIDED.
2. SEE DRAWING A-91230 FOR SUGGESTIONS ON MOUNTING TO CEILING-SUSPENDED BACKSTOPS.
3. FOR PORTABLE BACKSTOPS, CONTACT THE BACKSTOP MANUFACTURER FOR MOUNTING HARDWARE.

BB-2115

WEIGHTS	
SHIPPING WEIGHT	MOUNTING WEIGHT
40 LBS (10 KG)	30 LBS (7 KG)

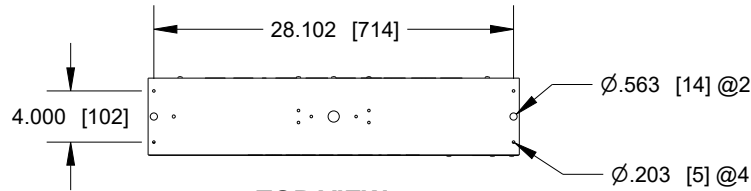

TOP VIEW

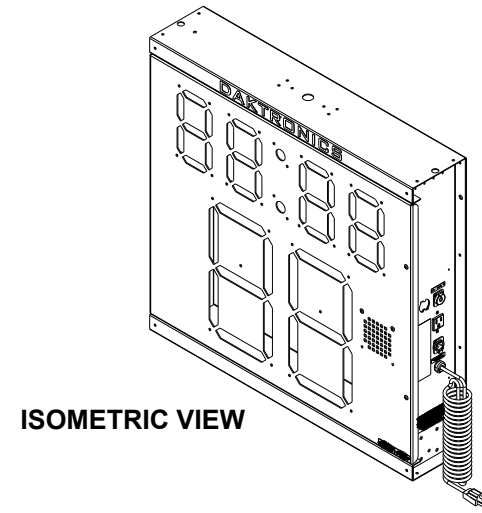

ISOMETRIC VIEW

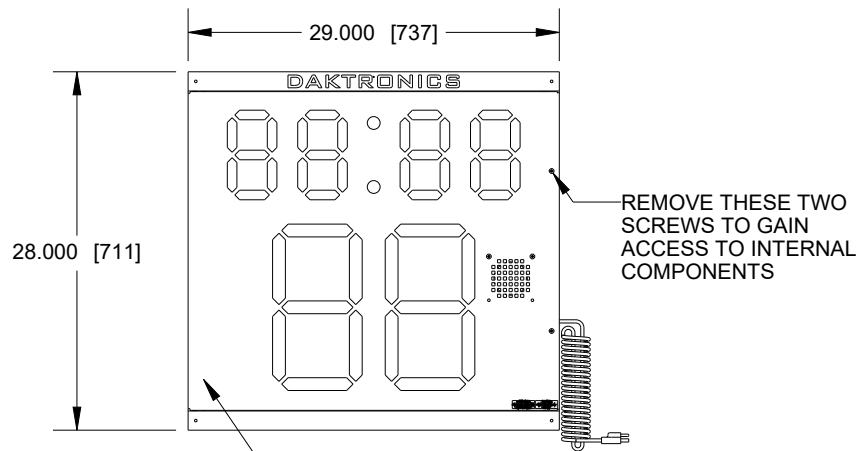

FRONT VIEW

FACE PANEL SWINGS OPEN TOWARDS THE LEFT ON INTERNAL HINGES

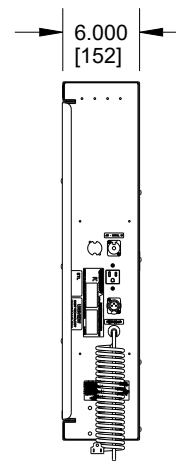

SIDE VIEW

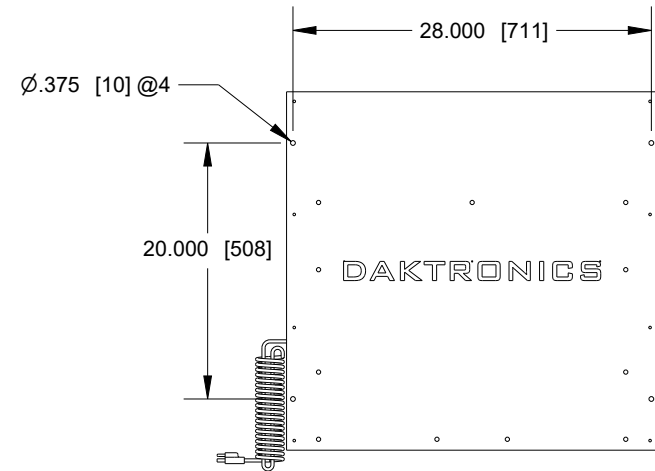

REAR VIEW

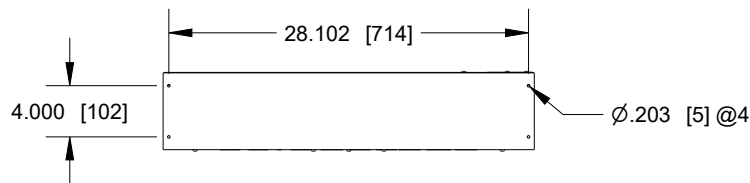

BOTTOM VIEW

TUFF SPORT® IS A COPYRIGHT OF DAKTRONICS

REV:	DATE:	DESCRIPTION:	BY:
		<small>THE CONCEPTS EXPRESSED AND DETAILS SHOWN ON THIS DRAWING ARE CONFIDENTIAL AND PROPRIETARY. DO NOT REPRODUCE BY ANY MEANS WITHOUT THE EXPRESS WRITTEN CONSENT OF DAKTRONICS, INC. OR ITS WHOLLY OWNED SUBSIDIARIES. COPYRIGHT 2022 DAKTRONICS, INC. (USA)</small>	
PROJECT: TUFF SPORT® SCOREBOARDS			
TITLE: MECHANICAL SPEC; BB-2115			
DATE: 12-MAY-22	DIM UNITS: INCHES [MILLIMETERS]	SHEET	REV
SCALE: 1/15	DO NOT SCALE DRAWING		00
DESIGN: NWINTER	JOB NO. P1237	FUNC - TYPE - SIZE E - 07 - A	5052523
DRAWN: NWINTER			

DIGIT, SIGNAL AND POWER SPECIFICATIONS:

BB-2115

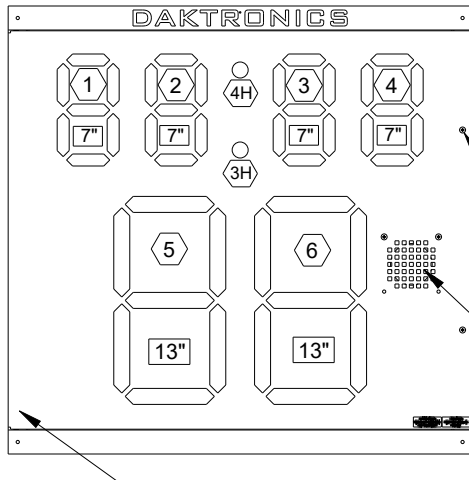

FRONT VIEW

FACE PANEL SWINGS OPEN TOWARDS THE LEFT ON INTERNAL HINGES

(OPTIONAL) AMBER LIGHT STRIP CONTROL

REMOVE THESE TWO SCREWS TO GAIN ACCESS TO INTERNAL COMPONENTS

HORN (DS1)
DEFAULT SETTINGS:
GAME HORN & SHOT HORN

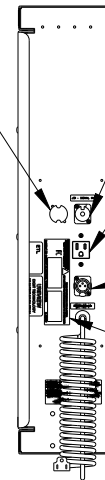

SIDE VIEW

SIGNAL INPUT (J31)

SWITCHED AC OUT (J42)
120V DISPLAYS ONLY

LIGHT STRIP (J32)

MODEL NUMBER & POWER REQUIREMENTS

LEGEND:

- = DIGIT DESIGNATION IN RELATION TO DRIVER
- = DIGIT SIZE
- = SEGMENT DESIGNATION
- = DRIVER NUMBER

COMPONENT LOCATIONS:

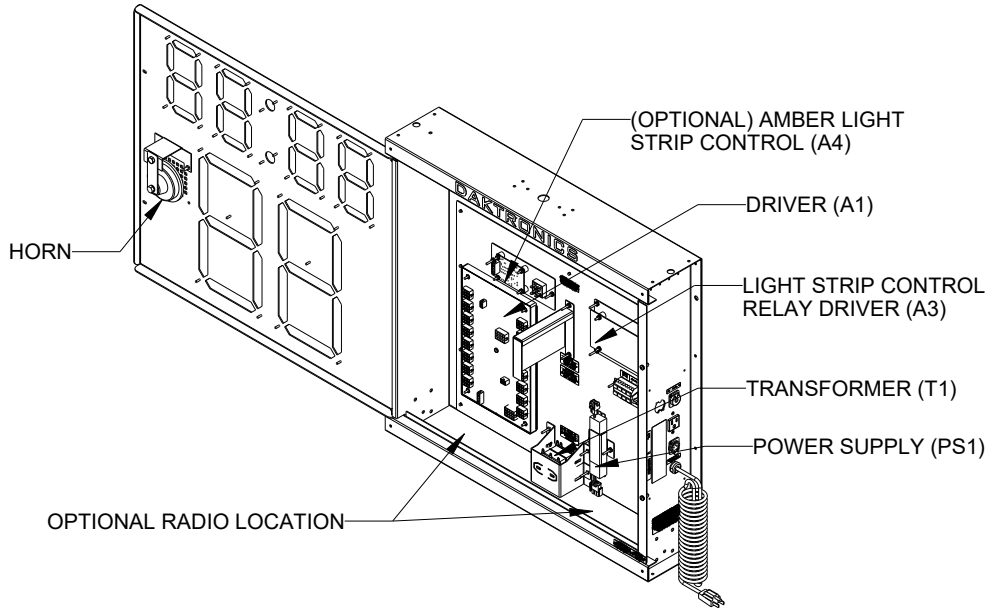

ROTATED VIEW WITH OPEN DOOR

NOTES:

1. A3 BOARD CAPABILITIES ARE GAME HORN, SHOT HORN, CLK = STOP, CLK = 0. J32/J42 (TOGETHER), & HORN CAN BE SET TO DIFFERENT VALUES IF REQUIRED.

2. TO CHANGE DEFAULT FUNCTION OF HORN, ENABLE OTHER SEGMENTS, OR CHANGE LIGHT STRIP OPTIONS, REFER TO DWG A-179151. TUFF SPORT® IS A COPYRIGHT OF DAKTRONICS

REV: 01	DATE: 02 MAR 23	DESCRIPTION: PER CN-155736, CHANGED LIGHT STRIP CONTROL, OUTLET, AND SWITCHED OUTLET FROM OPTIONAL TO INCLUDED	BY: DRO 04920
		THE CONCEPTS EXPRESSED AND DETAILS SHOWN ON THIS DRAWING ARE CONFIDENTIAL AND PROPRIETARY. DO NOT REPRODUCE BY ANY MEANS WITHOUT THE EXPRESS WRITTEN CONSENT OF DAKTRONICS, INC. OR ITS WHOLLY OWNED SUBSIDIARIES. COPYRIGHT 2022 DAKTRONICS, INC. (USA)	
PROJECT: TUFF SPORT® SCOREBOARDS			
TITLE: COMPONENT LOCATION; BB-2115			
DATE: 02-MAR-23	DIM UNITS: INCHES [MILLIMETERS]	SHEET	REV 01
SCALE: 1/12	DO NOT SCALE DRAWING		
DESIGN: NFWINTER	JOB NO. P1237	FUNC - TYPE - SIZE E - 07 - A	5052524
DRAWN: NFWINTER			

Sports Facility Maintenance

7915 Harney Street
Omaha, NE 68114 US
402-618-4353
casey@sportsmaint.com



Estimate

ADDRESS

Steve Decker
Franklin Public Schools
1001 M Street
Franklin, NE 68939

ESTIMATE # 1063

DATE 03/11/2024

QTY DESCRIPTION

SHOT CLOCK INSTALL

.

- 2 Install Shot Clocks (Install only. School to provide Shot Clocks)
- 2 Purchase Shot Clock Brackets
- 2 Install End Of Period Lights
- 1 Install two wall bucks and add chains to the south backstop to support the additional weight of the shot clocks and brackets
- 1 Lift Charge
- 1 Travel

.

NOTE: This is a wireless install for the shot clocks. If new receivers need to be installed into the score boards, that is not included since we do not know what shot clock system has been purchased.

.

NOTE: No electrical is included in this proposal. An electrician will need to get 110V power to each backstop.

TOTAL

\$4,525.00

Accepted By

Accepted Date

FRANKLIN PUBLIC SCHOOLS --- 2024 INSURANCE RENEWAL

	ALICAP PREMIUM	EMC PREMIUM	ALICAP DEDUCTIBLE	EMC DEDUCTIBLE	ALICAP LIMITS	EMC LIMITS
CYBER LIABILITY	included	\$2,497		\$10,000		\$500,000
COMMERCIAL PROPERTY	included	\$42,795	\$500	\$5,000	\$400,000,000	\$32,693,904
GENERAL LIABILITY	included	\$2,678				
COMMERCIAL INLAND MARINE	included	\$1,328				
BUSINESS AUTO	included	\$13,980				
COMMERCIAL UMBRELLA	included	\$4,973				
LINEBACKER	included	\$2,757		\$2,500		
COMMERCIAL CRIME	included	\$188	\$0	\$250	\$1,000,000	\$25,000
POLLUTION LIABILITY	included					
	\$55,896	\$71,196				
	ALICAP PREMIUM TOTAL	EMC PREMIUM TOTAL				
TREASURERS BOND	included in premium total	\$250				
WORKERS' COMPENSATION PREMIUM	~\$15,000.00	\$9,704				
	ALICAP	EMC				

March Board Meeting

Technology:

The check for computers we sent off in November should here soon. (Sent last Wednesday)

Shop classes are building new cabinets for tech room to store technology more efficiently.

AD:

Spring sports start this week. Track at UNK indoor on Thursday. 40 kids out for track this year. Golf starts on March 27th. 8 kids are out for golf. eSports Spring season is half over. Both Rocket League teams are in the top 12. Fortnite team 1 is in the top 10.



Elementary Principal's Report

Mrs. Shelley Kahrs

March 2024

Franklin Elementary Ranks #23 in the state!

<https://www.usnews.com/education/k12/elementary-schools/nebraska>



Franklin Elementary School

1001 M St, Franklin, NE 68939 | (308) 425-6283 | [Website](#)

Badge Eligible

#23 in Nebraska Elementary Schools

Overall Score 95.5/100

Nebraska Bullying Prevention and Response Workshop

On March 13th, Mrs. Stratman and I will be taking a group of teachers to the Nebraska Bullying Prevention and Response Workshop in Lincoln. Bullying and harrasment behaviors are increasing and having a negative impact in the world of edcuation and society. The training is a "train the trainer" event that will provide resources, training and knowledge to our team so we will be able to bring this back to train others on responding to these situations of bullying, harrasment and alegations.

Dennis Lewis will cover topics on:

- conveying to staff, students, and parents the difference between conflict and bullying
- organizational and personal liability
- classroom and school strategies to minimize bullying
- responding to and investigating
- working with parents and students
- the cyber element

Those staff attending will be Mrs. Scott, Mrs. Erica Bonham, Mr. Solass, Mrs. Becky Cleveland, Mrs. Stratman and Mrs. Kahrs.

Meetings or Activities:

February 21st: TVC Speech

February 28th: MTSS Team Meeting

February 23rd Mike Donahue Value Up Presentation

February 29th: Cynthia's Bouquet and Lattes Valentine Celebration

February 29th: Attended Franklin's Workforce Housing Meeting

March 1st: Dr. Seuss Reading Challenge Kick-Off

March 11th: Reunification Method Workshop in Hastings

Numerous MDT, IEP, and SAT parent meetings



Chris Lecher
Superintendent

Christie Stratman
Secondary Principal

Shelley Kahrs
Elementary Principal

Mrs. Stratman's Middle//High School March Principal Report

Activities:

02/12-16/24 FCCLA Week
02/19-23/24 FFA Week
02/19/24 Drive your Tractor to School
02/20/24 FFA Supporters Breakfast
02/20/24 Drug Testing (1) 1st offender, 30 days activity suspension, (3) 2nd offenders, 60 days of activity suspension
02/22/24 Lt. Monty Lovelace from the Nebraska State Patrol spoke at the Franklin Chamber of Commerce lunch and learning meeting

Trainings:

02/29/24 Export Your Powerschool Data 101
Data Export Manager 201

Upcoming Trainings:

03/13/24 Nebraska Bullying Prevention and Response Workshop in Lincoln
This workshop is going to train us how to teach others in our district how to respond to bullying and give us the resources to help aide in trying to decrease it in our district.

Student Success:

- *TVC Speech Champions
- *High School Quiz Bowl 3rd Place in Alma
- *Middle School Quiz Bowl 2nd Place in Alma
- *Calvin Carraher placing 5th at State Wrestling
- *Sophomores are busy working hard on their dance for prom.
- *Juniors are preparing for Prom
- *Sophomores will be taking the practice ACT
- *Juniors will be taking the ACT
- *State Qualifiers for Future Problem Solvers

High School Teams: Trace Bislow, Bethany Haussermann, Macy Lenneman and Eldon Haack. The other team of Allison Boettcher, Steel Marks, Alex Gladden and RJ Largent
6th Grade: Boden Bush, Gus Haack, Ruby Edwards, Bailey Dallman and Silas Elliot

Meetings:

Weekly middle school core teacher meetings, Middle and High School MTSS, IEP and MDT meetings

1001 M St, Franklin, NE 68939
308-425-6283 (phone) 308-425-6553 (fax)
www.fpsflyers.org

"Success through the Flyer Way happens at FPS EVERY DAY"



FRANKLIN PUBLIC SCHOOLS

HOME OF THE FLYERS

Chris Lecher
Superintendent

Christie Stratman
Secondary Principal

Shelley Kahrs
Elementary Principal

:

1001 M St, Franklin, NE 68939
308-425-6283 (phone) 308-425-6553 (fax)
www.fpsflyers.org

"Success through the Flyer Way happens at FPS EVERY DAY"



Chris Lecher
Superintendent

March 11, 2024

- Staffing update
- Teacher candidate shortage
- Six months into budget and we are 15% under our General Fund budget
- Chamber meeting was here on Feb. 20th (Internet crimes against children presentation by NSP)
- Infrared scan of building
- Legislative update
- Reunification training
- I had 20 office days in February.
- **WE HAVE AWESOME STUDENTS AND STAFF AT FPS!!!**
- **It's a GREAT day to be a Flyer!!!!**