



Mission Consolidated Independent School District

- 1201 Bryce Drive, Mission, Texas 78572
- Telephone: (956) 323 5505 Fax: (956) 323 5634
- Website: www.mcisd.net

Notice and Agenda

The Board of Trustees of the Mission Consolidated Independent School District will hold a **Regular Meeting** on **Wednesday, April 13, 2022, at 6:30 PM** in the **Mission CISD Annex, 925 E. Business HWY. 83, Mission, Tx 78572**. At this meeting, the Board may deliberate or act on any of the subjects listed on the following agenda. The President may change the order of items listed below for the convenience of the Board.

A G E N D A

I. Call to Order and Establish Quorum	
II. Pledge of Allegiance and Moment of Silence	
1. U. S. Flag and Texas Flag -	
2. Mission Vision Statement -	
III. Comments from the Public	
IV. Public Comment(s) on Specific Agenda Item(s)	
V. Superintendent's Updates and Recognitions	
1. PCAT Bus Driver of the Year	4
VI. Presentation(s) to the Board of Trustees	
1. Self-Funded Health Insurance Update	5
2. Budget Update	
3. Annual Compliance Announcement of Board of Trustees' Continuing Education Credit (CEC) Hours	30
VII. Discussion and Possible Action	
1. Approval of Purchase of Veterans Memorial High School Marching Band Uniforms	31
2. Consideration and Approval to Accept Best and Final Offer (BAFO) for Supplemental Repairs (Visitors Side) for the Tom Landry Stadium Repairs Project – Ricardo Hinojosa Engineering, Inc.	32
3. Consideration and Approval to Accept Best and Final Offer (BAFO) for Synthetic Turf for the Baseball & Softball Fields at Mission High School and Veterans Memorial High School – Javier Hinojosa Engineering	57
4. Consideration and Approval to Accept Best and Final Offer (BAFO) for Demolition of the Technology/Radio Tower Project – Chanin Engineering	61
5. Consideration and Approval of Change Order #02 for Unforeseen Additional Roof Damage and Additional Fifteen (15) Delay Days for the Lee Field House Roofing Project – Raba Kistner	64
6. Approval of Budget Amendment	79

VIII. Recommendation(s)

- 1. Approval of the Selection for:**
 - a. Director for Budget and Finance**

IX. Recommendations and Approval for Employment and Contract Status of Classroom Teachers and Other Non-Administrative Professional Personnel

- 1. Re-Employ Probationary Contract Employees**
- 2. Terminate Probationary Contract Employees**
- 3. Renew Term-Contract Employees**
- 4. Propose Non-Renewal Term Contract Employees**
- 5. Offer Employment Agreement to Eligible Employees**

X. Items to Consider: The Board will consider and may act on the following items under a CONSENT AGENDA. Any Trustee may request the removal of an item from the CONSENT AGENDA for individual consideration and action.

- 1. Approval of Close Up Leadership Conference in Washington, D.C.** 81
- 2. Approval of TSTC Migrant Academic Achievement Residency Summer Experience (MAARS)** 82
- 3. Approval of UTRGV Migrant University Summer Experience (MUSE)** 84
- 4. Approval of Summer Programs for 2022** 85
- 5. Approval of Out-of-State Trip For Destination Imagination Teams Advancing to Global Finals in Kansas City, Missouri** 91
- 6. Approval to Accept Final Design for the Culinary Arts for Mission High School – PBK Architects** 92
- 7. Approval to Accept Final Design for the Culinary Arts for Veterans Memorial High School – PBK Architects** 105
- 8. Approval to Accept Final Design for the Additional Animal Pens for the Agricultural Science Barns Project – PBK Architects** 112
- 9. First Reading of Changes to Board Policies:**
 - a. FO (LOCAL): Student Discipline**
 - b. FNCA (LOCAL): Student Conduct Dress Code**
- 10. Approval of the Election Services Contract for the May 7, 2022 Mission CISD Board of Trustees Election with the Hidalgo County Elections Administrator** 126
- 11. Approval to Amend Order of General Election for the May 7, 2022, Mission CISD Board of Trustees Election to include the approved District polling locations as County Wide Polling Locations** 137
- 12. Approval of the Interlocal Participation Agreement (IPA) between TASB Risk Management Fund and Mission CISD** 141
- 13. Approval of Bids, Proposals and Purchases of \$50,000 and Over**
 - a. Contract Renewal for Independent Financial Audit Services** 150
- 14. Approval of Minutes**
 - a. November 10, 2021 Regular Board of Trustees Meeting** 161
 - b. December 8, 2021 Special Board of Trustees Meeting** 186
 - c. December 15, 2022 Regular Board of Trustees Meeting** 190
 - d. January 5, 2022 Special Board of Trustees Meeting** 199
 - e. January 12, 2022 Special Board of Trustees Meeting** 203
 - f. January 19, 2022 Regular Board of Trustees Meeting** 207

XI. Executive Session

- 1. Private Consultation with Board Attorney (Texas Gov't Code §551.071)**

2. Deliberate the purchase, exchange, lease, or value of real property (Texas Gov't Code § 551.072)	
3. Deliberate the Appointment, Employment, Evaluation, Reassignment, Duties, Discipline, or Dismissal of a Public Officer or Employee or to Hear a Complaint or Charge Against an Officer or Employee (Texas Gov't Code §551.074)	
XII. Action, if Necessary, on Matters Discussed in Executive Session	
XIII. Board of Trustees Information Items	
1. Memorandum of Understanding with KidsU US, Inc. OA Fueling Brains	213
2. Personnel Employments, Resignations, Transfers, and Compensation Change	226
3. Financial Reports for February 2022	
a. General Funds and Debt Service	227
b. Tax Levy Adjustments	230
c. Disbursements	235
d. Donations	236
4. Statement of Impact from George Gervin Academy	238
5. Statement of Impact from Vanguard Academy Charter School	241
XIV. Important Dates to Remember	
1. April 15 and 18, 2022, Easter Holidays	
2. May 4, 2022, Board of Trustees Workshop at 6:30 p.m.	
3. May 11, 2022, Regular Board of Trustees Meeting at 6:30 p.m.	
XV. Adjournment	

In accordance with the Texas Open Meetings Act, the Board may enter into a closed meeting to deliberate any item that is listed above that fits within an exception listed in Subchapter D. Any final action, decision, or vote on a subject deliberated in closed meeting will be taken in an open meeting held in compliance with the Texas Open Meetings Act.

This Notice was posted by 5:00 p.m., on April 8, 2022.

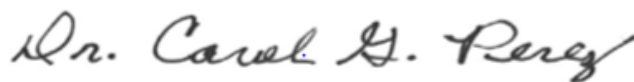

**Dr. Carol G. Perez, Superintendent of Schools
Mission Consolidated Independent School District**

SUBJECT: Property Casualty Alliance of Texas (PCAT) Bus Driver of the Year

PRESENTER: Chase Carlisle, Carlisle Insurance

BACKGROUND INFORMATION

The PCAT *Bus Driver of the Year program* wants to honor the best of the best: The Mission CISD bus driver who exhibits professionalism in all that he/she does to help Mission CISD safely transport students to and from school every day. The PCAT *Bus Driver of the Year* is an employee recognition program based on a subjective nomination and selection process. PCAT wants to honor a deserving bus driver who exemplifies the best that the transportation department has to offer in the Five Character Points:

- *LEADERSHIP*
- *ATTITUDE*
- *PERSEVERANCE*
- *STUDENT AND PARENT RELATIONSHIPS*
- *TECHNICAL SKILL*

LEADERSHIP: Leaders aren't just those that carry the title of supervisor/manager. Leaders are those who go the 'extra mile' to serve those around them and other employees look up to.

ATTITUDE: The bus driver who consistently displays a good attitude and others depend on him/her to set the tone for the shift. The bus driver who look for the best in people and sees a bigger picture and a bigger purpose for the transportation department.

PERSEVERANCE: The bus driver who has overcome significant hardships and has fallen down but gotten back up again. The bus driver who sticks with his/her convictions, even when the sledding gets tough.

STUDENT AND PARENT RELATIONSHIPS: The bus driver who has a good working relationship with their students and parents and are they respected by both.

TECHNICAL SKILL: Is a great driver – one who drives safely and skillfully at all times, never takes safety shortcuts, and is sought out by other drivers as a driving mentor.

ADMINISTRATIVE CONSIDERATIONS

On behalf of PCAT, it is our honor to present Mr. Raul Cantu with the 2021-2022 PCAT Bus Driver of the Year commendation, along with a 20 oz Yeti tumbler and tote, both embossed with the Bus Driver of the Year. Please help us congratulate Mr. Cantu.

FUNDING SOURCE:

Not applicable

RECOMMENDATION:

Not applicable

CONTACT PERSON (S)

Joel Garcia, Assistant Superintendent for Finance
Sylvia Cruz, Director for Payroll, Employee Benefits and Risk Management
Veronica Garcia, Workers Compensation/Safety Manager



Self-Funded Group Health Plan

5

April 13, 2022

*Sylvia Cruz, Director of Risk Management, Mission CISD
Valeria Ybarra, Consultant, Carlisle Insurance*



Self-Funded Health Insurance Fund Statement of Revenues, Expenses and Changes in Net Position for 9 months ending March 2022

Operating Revenues	Actual	%
<i>Premiums:</i>		
Medical - Employee	\$ 2,246,128.98	18.14%
Medical - Employer	\$ 8,498,833.15	68.65%
Administrative Fees-Refunds	\$ -	0.00%
Claim Credits		0.00%
Pharmacy Credits/Rebates	\$ 378,037.87	0.00%
Stop Loss Insurance	\$ 1,252,449.91	0.46%
Cobra	\$ 3,686.42	0.03%
Non - Operating Revenues		
Interest Revenue	\$ 19.38	0.00%
Total Revenues	\$ 12,379,155.71	87%
Operating Expenses		
<i>Claims:</i>		
Medical	\$ 9,588,091.01	73.81%
Pharmacy - RX	\$ 2,622,770.35	20.19%
<i>Administrative Fees:</i>		
Medical	\$ 36,070.12	0.28%
Aggregate Stop Loss	\$ 53,021.45	0.41%
Specific Stop Loss	\$ 625,674.95	4.82%
Independent External Review Fees	\$ -	0.00%
Vendor Fees	\$ 4,340.94	0.03%
PCORI Fees	\$ 417.10	0.00%
Consulting Fees	\$ 49,500.00	0.38%
Non-Operating Expenses		
Other Expenses	\$ 10,825.18	0.08%
Total Expenses	\$ 12,990,711.10	100.00%
Operating Income (Loss)		
	\$ (611,555.39)	
Income (Loss) Before Contributions & Transfers		
	\$ (611,555.39)	
Contributions & Transfers		
Transfers In	\$ -	
Change in Net Position	\$ (611,555.39)	
Total Net Position - Beginning Unaudited	\$ -	
Total Net Position - Ending Unaudited	\$ (611,555.39)	



Net Position Overview

12 month Trend - March 2022

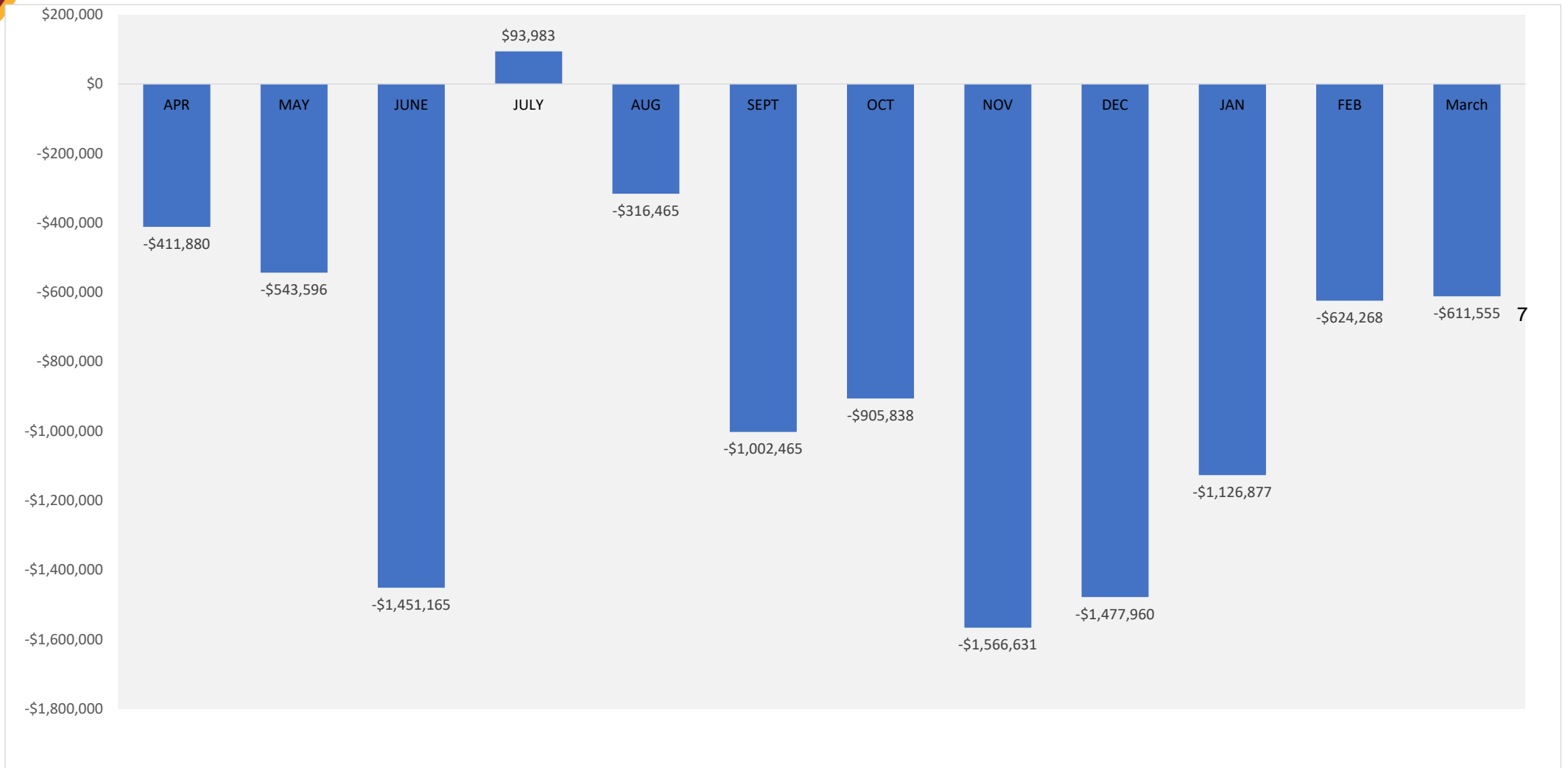

Pharmacy & Medical – Paid Claims October 2021 – February 2022

Overall Financial Summary

	Oct 2020 – Feb 2021	Oct 2021 – Feb 2022	% Change
Total			
Paid (Medical)	\$4,180,869	\$5,225,926	25.00%
Pharmacy Paid	\$1,649,548	\$1,463,379	-11.30%
Overall	\$5,830,417	\$6,689,305	14.70%
PEPM			
Paid (Medical)	\$406	\$500	23.30%
Pharmacy Paid	\$160	\$140	-12.50%
Overall	\$566	\$640	13.20%

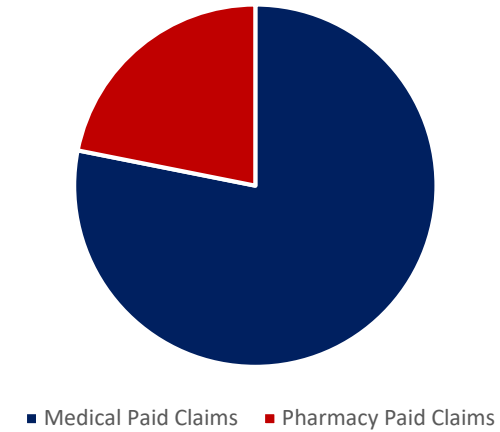

8



Pharmacy & Medical – Paid Claims October 2021 – February 2022

Month by Month Comparison (Paid PEPM)

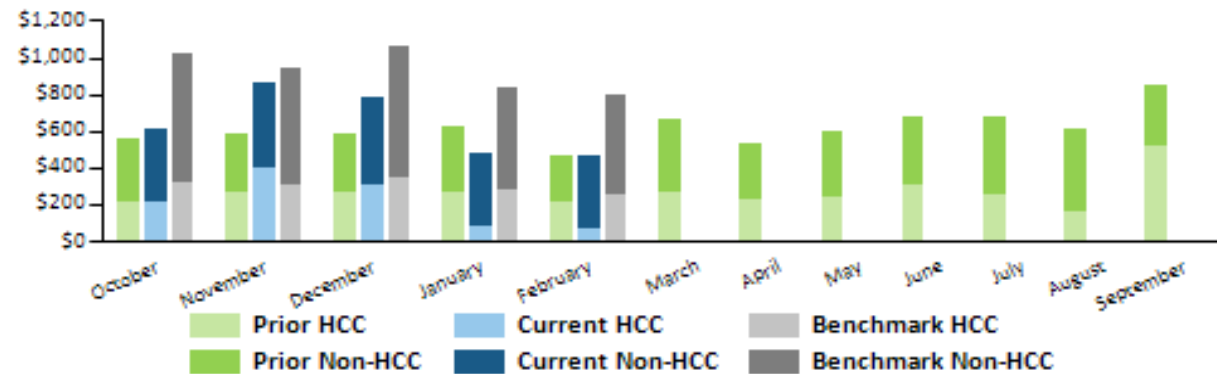

Medical Spend Breakdown

Service Category	Place of Service	Oct 20 - Feb 21	Oct 21 - Feb 22	Increase / Decrease
FACILITY INPATIENT				
	INPATIENT HOSPITAL	\$1,328,059	\$1,929,888	45%
	SKILLED NURSING FACILITY	\$30,750	\$12,220	-60%
	RESIDNTL SUBSTANCE ABUSE TRTMNT FAC	\$3,135	\$0	-100%
Total		\$1,361,944	\$1,942,108	43%
FACILITY OUTPATIENT				
	HOME	\$1,068	-\$121	-111%
	INPATIENT HOSPITAL	\$5,456	\$0	-100%
	OUTPATIENT HOSPITAL	\$1,268,275	\$1,416,415	12%
	AMBULATORY SURGICAL CENTER	\$19,815	\$11,891	-40%
	HOSPICE	\$15,572	\$1,800	-88%
	RESIDNTL SUBSTANCE ABUSE TRTMNT FAC	\$85,966	\$0	-100%
	END-STAGE RENAL DISEASE TRTMT FAC	\$45,090	\$21,245	-53%
Total		\$1,441,242	\$1,451,231	1%
PROFESSIONAL				
	OFFICE	\$1,037,235	\$1,387,686	34%
	HOME	\$22,356	\$34,727	55%
	INPATIENT HOSPITAL	\$161,741	\$178,957	11%
	OUTPATIENT HOSPITAL	\$100,676	\$112,632	12%
	EMERGENCY ROOM-HOSPITAL	\$18,641	\$43,155	132%
	AMBULANCE - LAND	\$34,668	\$30,770	-11%
	OTHER PLACE OF SERVICE	\$2,365	\$44,660	1788%
Total		\$1,377,683	\$1,832,587	33%
PHARMACY				
	PHARMACY	\$1,649,548	\$1,463,379	-11%
Total		\$1,649,548	\$1,463,379	-11%
Total: All		\$5,830,417	\$6,689,305	15%

10



High-Cost Claimant and Stop-Loss Analysis

Specific Deductible: \$250,000

Claimants over \$50,000

Member	Relationship	Total Paid (Medical / Rx)	Specific Deductible	Percent of Specific Met	Excess of Loss Limit	Stop Loss Reimbursement
Claimant 1	Dependent	\$497,298	\$250,000	199%	\$247,298	\$246,790
Claimant 2	Employee	\$337,959	\$250,000	135%	\$87,959	\$87,959
Claimant 3	Dependent	\$269,259	\$250,000	108%	\$19,259	\$19,259
Claimant 4	Spouse	\$261,788	\$250,000	105%	\$11,788	\$10,926
Claimant 5	Employee	\$213,757	\$250,000	86%	(\$36,243)	
Claimant 6	Spouse	\$171,942	\$250,000	69%	(\$78,058)	
Claimant 7	Employee	\$173,331	\$250,000	69%	(\$76,669)	
Claimant 8	Spouse	\$80,732	\$250,000	32%	(\$169,268)	
Claimant 9	Employee	\$76,022	\$250,000	30%	(\$173,978)	
Claimant 10	Employee	\$60,605	\$250,000	24%	(\$189,395)	
Claimant 11	Dependent	\$54,913	\$250,000	22%	(\$195,087)	
Claimant 12	Dependent	\$51,222	\$250,000	20%	(\$198,778)	
Total		\$2,248,828.00			\$354,516	\$364,934

11

Total Claims	\$6,689,305	
Large Claimants	\$2,248,828	34%

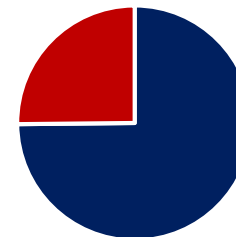

■ Total Claims ■ Large Claimants



Action Items

COMPLETED

- Effective 2/1/2022
- Implement new Rx formulary
 - Estimated savings:
\$205,793
- Review of claims through the month of February 2022 compared to previous year
- Received \$89,514 in Stop Loss reimbursements reducing the negative overall claim balance to \$611,555

IN PROGRESS

- Employee and Employer contribution Review (May 2022)
- Benchmarking (May 2022)
- Utilization impact analysis (Renewal):
 - Emergency Room
 - Pharmacy spend
 - Hospital Utilization
 - Weight Loss Surgery

LONG TERM

- Ensure benefit plan is relevant to industry standard
- Direct Contract (Hospital & Direct Clinical/PCP)

12





COVID-19 Update

April 13, 2022

*Valeria Ybarra, Consultant
Carlisle Insurance*

COVID Utilization (YOY) – Testing

COVID-19 Diagnostic Testing

Metrics	2020	2021	2022	Total
Claimants	989	2,006	661	2,506
Claims	1,707	4,815	955	7,477
Paid	\$137,154.69	\$450,192.74	\$101,807.68	\$689,155.11
Paid per Claimant	\$138.68	\$224.42	\$154.02	\$275.00
Paid Per Claim	\$80.35	\$93.50	\$106.60	\$92.17
Total Paid PMPM	\$3.48	\$11.71	\$15.72	\$8.17

COVID-19 Antibody Testing

Metrics	2020	2021	2022	Total
Claimants	111	78	17	199
Claims	128	96	18	242
Paid	\$6,540.86	\$4,720.38	\$890.47	\$12,151.71
Paid per Claimant	\$58.93	\$60.52	\$52.38	\$61.06
Paid Per Claim	\$51.10	\$49.17	\$49.47	\$50.21
Total Paid PMPM	\$0.17	\$0.12	\$0.14	\$0.14

14

Total Testing by Incurred Year

Metrics	2020	2021	2022	Total
Claimants	1,039	2,028	671	2,554
Claims	1,829	4,897	972	7,698
Paid	\$143,695.55	\$454,913.12	\$102,698.15	\$701,306.82
Paid per Claimant	\$138.30	\$224.32	\$153.05	\$274.59
Paid Per Claim	\$78.57	\$92.90	\$105.66	\$91.10
Total Paid PMPM	\$3.65	\$11.84	\$15.86	\$8.32

COVID Utilization (YOY) – Treatment

COVID-19 Confirmed Claimants by Service Category

Service Category	2020	2021	2022	Total ↓
PROFESSIONAL				
Evaluation & Management	201	295	236	674
Pathology & Laboratory	36	73	116	217
Medical Services & Supplies (HCPCS II)	13	24	4	37
Radiology	19	16	4	37
Medical	9	5		13
Surgical	3	2		5
Anesthesia	1			1
Total : PROFESSIONAL	207	339	324	791
FACILITY OUTPATIENT				
Emergency Room	13	18	8	39
Pathology & Laboratory	5	5	3	12
Other Outpatient Services	1	4		5
Radiology	2	3		5
Observation Room		1		1
Total : FACILITY OUTPATIENT	19	28	11	57
FACILITY INPATIENT				
Medical	18	8	3	28
Post-Acute Care	2	1		2
Behavioral Health	1			1
Maternity		1		1
Total : FACILITY INPATIENT	19	10	3	30
Total : Selected Filter(s)	209	341	328	798

15

% of Paid by Service Category by Incurred Year

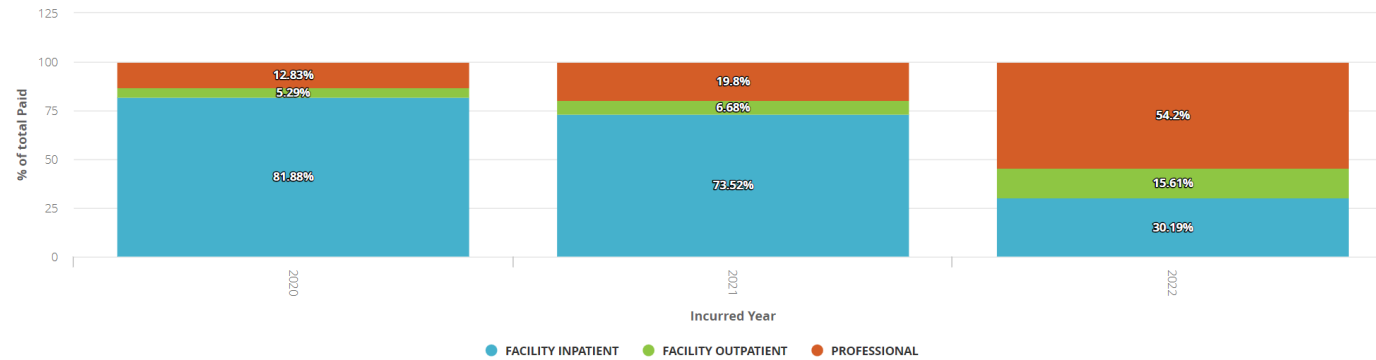



COVID-19 Overall Testing Claim Count by Incurred Month

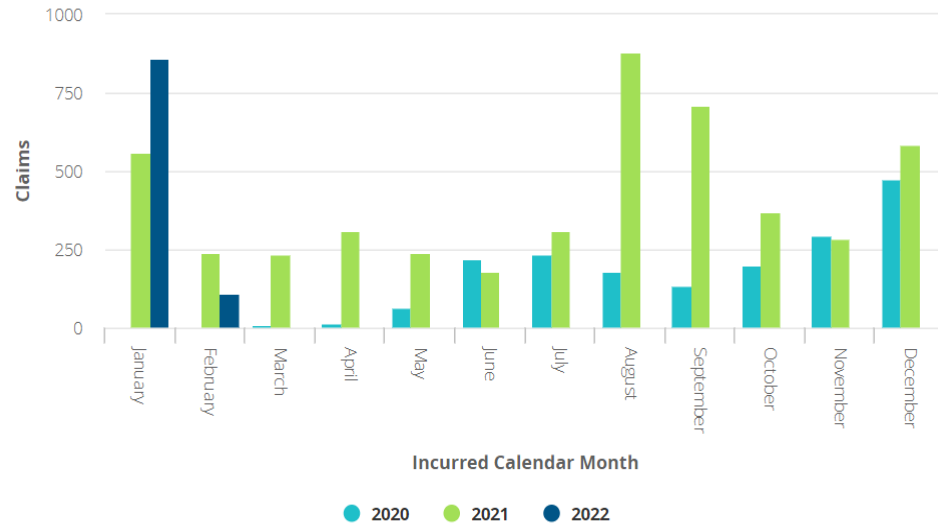

COVID-19 Overall Testing Paid by Incurred Month

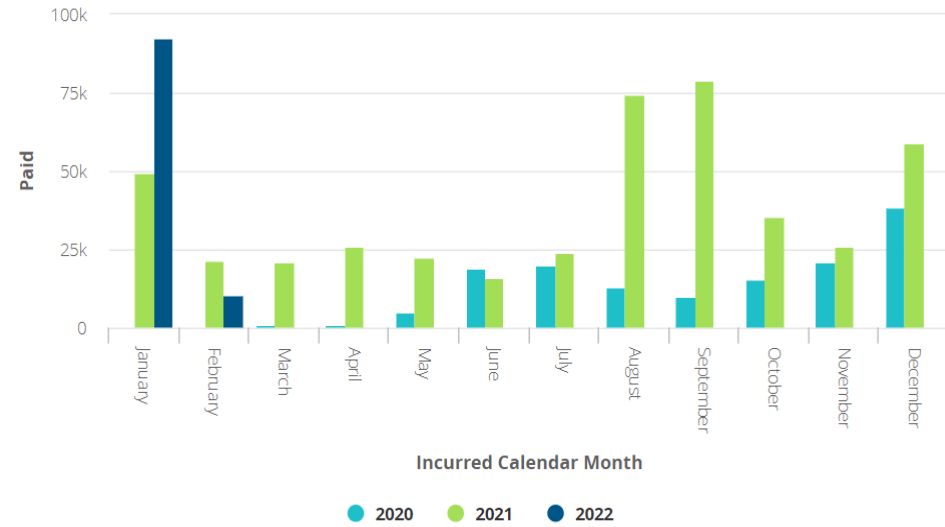

COVID-19 Treatment Claimant Count by Incurred Month

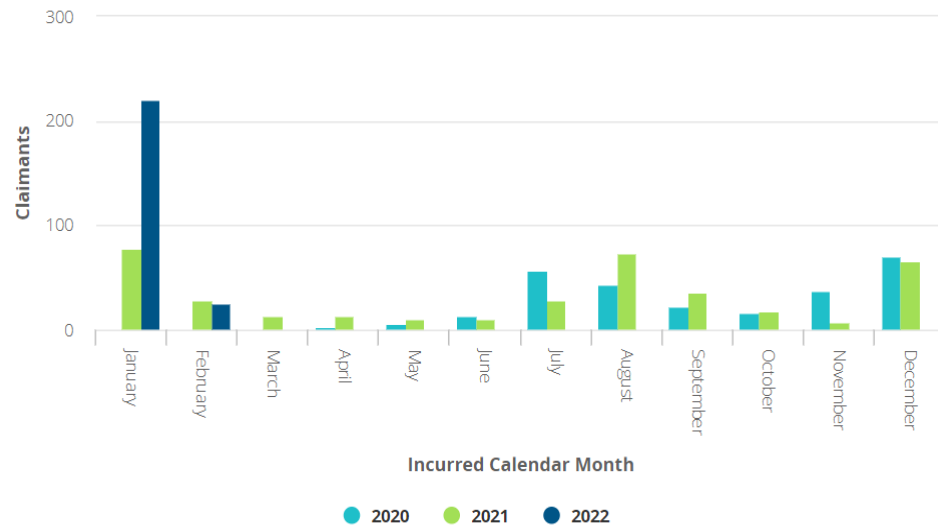

COVID-19 Treatment Paid by Incurred Month

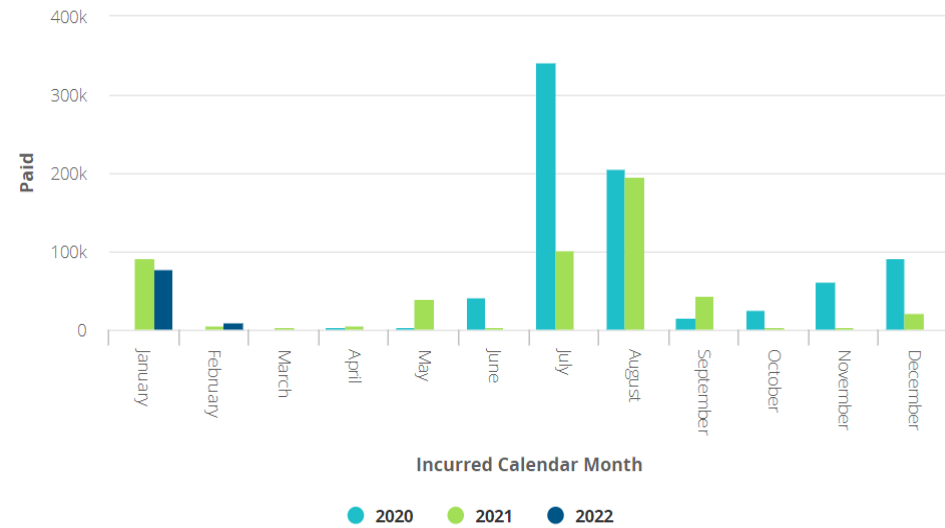

COVID-19 Current Plan Year Utilization October 2021 – February 2022

TESTING	CLAIMANTS	CLAIMS	PAID
Dependent	502	1,052	\$85,060
Spouse	62	87	\$9,948
Subscriber	1,221	2,683	\$258,347
Total	1,785	3,822	\$353,355

TREATMENT	CLAIMANTS	CLAIMS	PAID
Dependent	108	141	\$22,413
Spouse	22	64	\$179,432
Subscriber	230	689	\$125,333
Total	360	894	\$327,177

All			\$680,532
------------	--	--	------------------

Total Claims VS Claims with COVID-19 Diagnosis

	No	Yes	All
Claimants	2,761	522	2,814
Claims	18,196	1,162	19,258
Paid	\$4,855,465.53	\$370,460.40	\$5,225,925.93

Total Claims VS ALL COVID-19
Related Claims

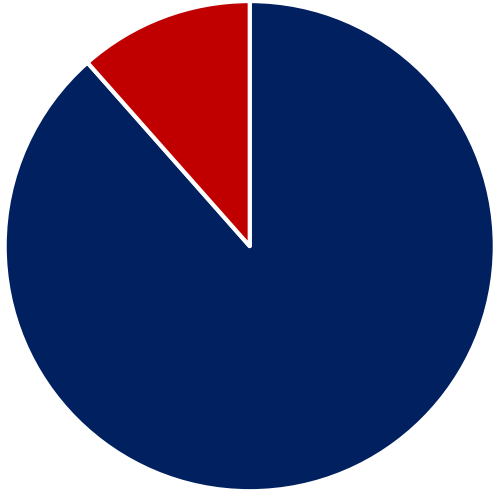

■ TOTAL CLAIMS ■ COVID IMPACT

*COVID -19 Claims account for 12% of overall claims from October 2021 through February 2022

Mission CISD's Wellness Initiatives





Fall 2021 Wellness Campaign – Better Together!!!

We challenged District Employees to cultivate positive interactions, connect with a nutritional accountability partner and commit to a “fitness-ship” with a fitness accountability partner.

Participation: 805 District Employees

BETTER TOGETHER

Fall 2021 Wellness Campaign

THE FALL WELLNESS CHALLENGE IS HERE!

Sign Up Now!

THE CHALLENGE BEGINS **September 13th**

PLEASE REGISTER BY **September 17th** TO ENSURE YOUR PRIZE.

TOOLS FOR THE CHALLENGE

Tracking Sheet

Week 1: Lean on Me **Week 2: Iron Sharpens Iron** **Week 3: Fitness-ship**

Join us in committing to building new and strengthening current relationships within family, work and social circles.

COMPLIMENTARY TUMBLER AND PLAYING CARDS FOR EVERY PARTICIPANT!

Edmark
Edmark, Inc.



FLU CLINICS

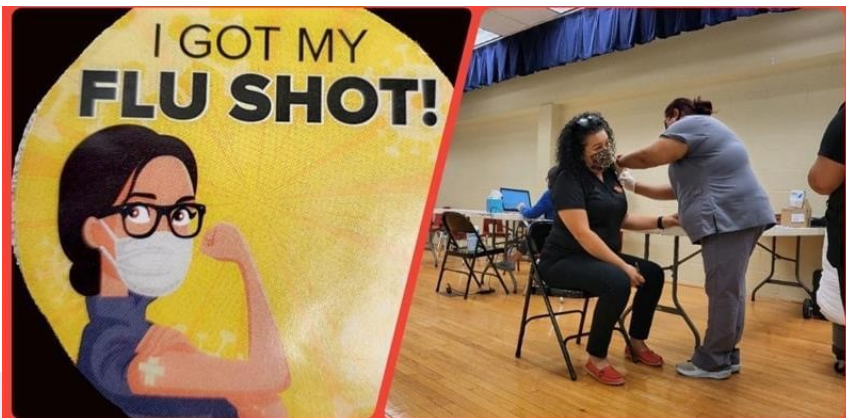
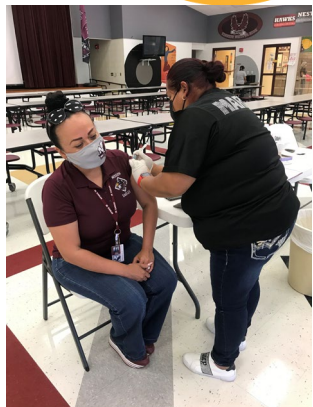

Location:	# of Participants
Central Office	60
Veterans Memorial High School	26
Kenneth White Jr. High	33
Midkiff	34
Cavazos	34
Bryan	38
Mission High School	35
Pearson	17
Rafael Cantu Jr. High	41



will be available at the following dates/locations:

October 14, 2021 (Thursday)
2:00 pm-5:00 pm
Veterans Memorial High

October 15, 2021 (Friday)
2:00 pm-5:00 pm
Kenneth White Jr. High

October 19, 2021 (Tuesday)
9:00 am-12:00 pm Midkiff Elementary
2:00 pm-5:00 pm Cavazos Elementary

October 20, 2021 (Wednesday)
9:00 am-12:00 pm Bryan Elementary
2:00 pm-5:00 pm Mission High School

October 21, 2021 (Thursday)
9:00 am-12:00 pm Pearson Elementary
2:00 pm-5:00 pm Rafael Cantu Jr. High

FLU SHOTS ARE FREE FOR EMPLOYEES & DEPENDENTS COVERED BY BCBS



Participation: 318 Employees



“Ladies Night Out” - Mission Regional Medical Center



LADIES night out

Mission CISD Employee Benefits Department is proud to partner with Mission Regional Medical Center

WHEN & WHERE

21

5:00 PM - 7:00 PM
Wednesday, Oct 20th &
Wednesday, Nov 3rd, 2021
Mission Regional Medical Center
Room A,B,C (Cafeteria)
990 S Bryan Rd, Mission, TX 78572

WHAT

Food and Refreshments
Live Music
Local Vendors
Mammogram Screenings

Stop by and visit with a physician to help answer your questions

Mammogram screening (8 slots)
Under 40 (referral needed)

Appointment & Questions?
Contact Employee Benefits Department at (956)-323-5545

Mission Regional Medical Center
Prime Healthcare

BREAST CANCER AWARENESS

Mission CSD



Wellness Wednesday Newsletter

- ✓ Eating healthy is all about **making smart choices to build an overall healthy dietary pattern**, which can help reduce your risk of heart disease and stroke. Eating right doesn't have to be hard or require you to give up all the foods you love!
- ✓ Eat a variety of nutritious foods from all the food groups. Nutrient-rich foods can help you [control your weight](#), cholesterol, and blood pressure.
- ✓ Eat less of the nutrient-poor foods. Limit foods and beverages high in calories but low in nutrients. Also limit the amount of [saturated fat](#), [trans fat](#) and [sodium](#) you eat. [Read Nutrition Facts labels](#) carefully — the Nutrition Facts panel tells you the amount of healthy and unhealthy nutrients in a food or beverage.



March 14th-20th is Brain Awareness Week

Studies have shown that when it comes to keeping the brain sharp, it is just as important to be mentally strong as it is to be physically strong. Our brain works just like any other muscle when it comes to staying in shape; we have to use it in order to maintain and improve its strength!

Our brain has the ability to build neural pathways called mental reserves when we learn something new, attain a new skill, or raise the difficulty of a previously easy task. The more we challenge our brain throughout our lifespan in a way that stimulates the development of these pathways, the greater our ability to remain agile, quick on our feet, and mentally active.

How can we "workout" our brains to keep them going strong?

- COMPLETE CROSSWORD OR SUDOKU PUZZLE
- START AN EXERCISE PROGRAM – DANCING, SWIMMING, WEIGHT TRAINING, YOGA
- READ A NEW BOOK, THE NEWSPAPER OR A MEDICAL JOURNAL
- KNIT OR CROCHET A NEW AND CHALLENGING STITCH PATTERN
- PLAY CARD GAMES THAT REQUIRE MEMORY, ATTENTION, COUNTING
- JOIN A SOCIAL CLUB – E.G., BOOK, GARDENING

We can only become as healthy as the time and energy we put into ourselves. Our brains deserve the attention we give the rest of our bodies. Let's challenge and nourish it with the fuel it needs to stay sharp, quick and strong!

Well-Connected Spring 2022

BLIND SPOT

While driving down the highway, have you ever switched lanes and been startled by a HONK from an angry driver that seemed to appear out of nowhere? Just as in driving, we all have a blind spot in our life. Do you know what yours is? Your spouse or best friend can probably easily point out a few.

All joking aside, when it comes to your health, in what area are you blind to seeing the importance and/or impact on your physical, mental or emotional wellbeing?

Awareness is the first step in transforming your blind spot into a new strength.

Convert Setbacks to Comebacks
Whether in the personal or professional arena, feedback from peers, family members or co-workers can be particularly helpful. If you are brave enough to open yourself up to the possibility of learning hard truths, you are also opening yourself up to growth and the opportunity for change.

Break Free of Damaging Patterns
Do you head straight to the fridge when you walk in the door, or perhaps snack mindlessly while you watch TV in the evening? In both situations, you're not particularly hungry, it's just habitual. This little routine may

be sabotaging your weight loss journey. Be intentional about your food choices. Eat out of hunger rather than boredom or habit and measure out an appropriate portion size.

Pause and Reflect
Take a moment and think about a situation in which you would like a different outcome. Without judgement or criticism, think about the experience objectively. What thoughts/feelings did you have in that moment? What skills or attributes would have helped to cultivate your desired outcome?

WITHOUT REFLECTION, WE GO BLINDLY ON OUR WAY, CREATING MORE UNINTENDED CONSEQUENCES, AND FAILING TO ACHIEVE ANYTHING USEFUL. —MARGARET WHEATLEY.

Fit Tip: HEALTHY EATING WHILE ON-THE-GO

When thinking of fast food, fried foods usually comes to mind. But if you navigate the menu wisely and are aware of potential high-fat, high-sugar items, you can have a healthy meal without sabotaging your diet.

- Opt for a broth based soup
- Get the grilled chicken
- Pick veggies and/or beans when possible
- Avoid sauces and gravy
- Choose salad with a lean protein & skip creamy dressings, bacon & cheese toppings

BlueCross BlueShield of Texas LifeTimes®

TEEN LONELINESS IS ON THE RISE: LEARN HOW YOU CAN HELP

Learn More

February 2022

Wellness WEDNESDAY

3 Tips to Combat The Rising Cost of Groceries

If you've noticed your grocery bill increasing slightly each month, you're not alone. Food prices across the country have increased by 6.8% since last year and are expected to keep rising.

The US Bureau of Labor Statistics reports that protein-rich foods have increased by 10.5% with beef leading the category with a 17.6% increase. With experts predicting that prices will continue to rise in 2022, try these steps to lessen the blow to your wallet and keep your budget on track.

DEALS

Take Advantage of Discounts: Keep an eye out for deals such as buy one, get one free or 2 for 1 offers.

GO MEATLESS

Indulge in Meatless Mondays: Choose cheaper cuts of meat or plant-based alternatives.

FRESH VS FROZEN

Compare Fresh vs Frozen Produce and Meats: Try to buy in bulk and freeze for later use.

Give Safety a Voice Loss Prevention

SAFETY SHORTS

Safety Short - Watch Your Step

Magellan Momentum

Preparing for 2022

Plans to move forward next year?

- Identify an aspect of your life that you find unexciting or boring.
- Create step-by-step measurable goals for reworking that aspect.
- Track your great progress over the year and make adjustments as needed.

Call your LIV program manager (LIV program number) or (800) 451-2222 for helpful resources.

Practicing mindfulness

Getting a better look with the present means to lose perspective. Mindfulness is a practice that helps you stay in the present moment and focus on the things you can control.

Let go of the past. Being present helps you realize that nothing is perfect and everyone has struggles. They just don't show you.

Call your LIV program manager (LIV program number) or (800) 451-2222 for helpful resources.



Central Office Wellness Room



23





Campus Wellness Rooms





KAIROS CAFÉ



Join Us
In The
Wellness
Room

for free

- Hot or Iced Cappuccino
- Hot or Iced Latte with Flavor:
 - Vanilla • Caramel
 - Sugar-Free Cinnamon Vanilla
 - Pumpkin Spice
- Hot or Iced Mocha
- Hot or Iced Americanos
- Hot Chocolate
- Regular Coffee

MON
FEB 21
8:30-11^{AM}





5K WALK/RUN – March 26, 2022



SPRING Into Wellness

5K

Bentsen Palm Park
1801 S. INSPIRATION

SATURDAY, MARCH 26, 2022

Our goal is to motivate our staff to live a healthier lifestyle.

Registration: 7 A.M. Start Time: 8 A.M.

Free T-Shirts
first 100 employees

Free Medals
first 100 participants

Free Event | No Fees | Onsite Registration

BACK TO SCHOOL BASH
Donations will be accepted for the 2022 Back to School Bash

Mission CISD
Employee Benefits
For more information:
956-323-5545

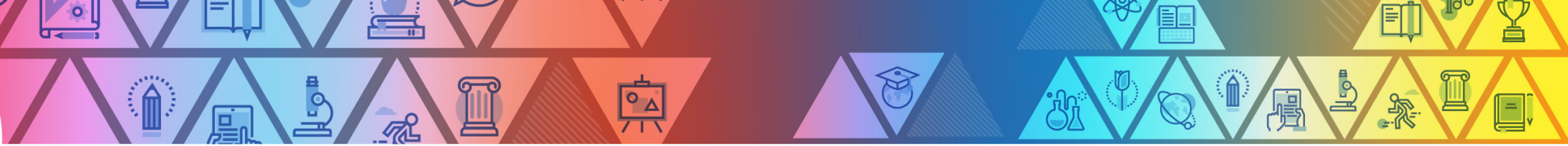

Ladies Night Out – Mission Regional Medical Center

Ladies Night Winners

- Patricia G. Ortiz – Rafael Cantu Jr. High – Donated by Dr. Shah
- Belinda Gaytan – Bryan Elementary – Donated by Mission Regional Medical Center
- Leticia Ibarra – Central Office – Donated by Heroes Dental
- Pura Reyna – Donated by Careers Academy
- Leonor Garcia – Central Office – Donated by Dr. Puig
- Diana Lerma – Veterans Memorial – Donated by Mission Regional Medical Center
- Maria Inez Trevino- Mission Collegiate – Donated by Mission Regional Medical Center
- Mary Rosales- Salinas Elementary – Donated by Mission Regional Medical Center
- Blanca Montalvo – Salinas Elementary – Donated by Palms Healthcare



Ladies Night Out

27

Join Us **Mission CSD**

Tuesday, March 29th
5:00 pm - 7:00 pm

FREE

- Mammogram Education
- Physician Presentations
- Snacks & Drinks
- Door Prizes

Doctor's Plaza West (1st Floor)
910 S. Bryan Rd. Suite 102
Mission Texas 78572
www.missionmc.org
Member of Prime Healthcare

The Breast Care Center at

Mission Regional Medical Center

Employee Benefits Servicing Schedule – April 2022

<div style="display: flex; justify-content: space-between; align-items: center;">  Employee Benefits Servicing Schedule </div>						
<div style="display: flex; justify-content: space-between; align-items: center;"> April 2022 </div>						
Sunday	Monday	Tuesday	Wednesday	Thursday	Friday	Saturday
					1	2
3	4	TESTING	TESTING	TESTING	TESTING	9
10	11 Alton Elementary (8:00 am – 11:00 am) Salinas Elementary (1:00 pm – 4:00 pm)	12 Cantu Elementary (8:00 am – 11:00 am) Alton Memorial Junior High School (1:00 pm – 4:00 pm)	13 Mission Collegiate High School (8:00 am – 11:00 am) Cavazos Elementary (1:00 pm – 4:00 pm)	14 Maintenance and Fixed Assets (8:00 am – 11:00) Transportation (1:00 pm – 4:00 pm)	15 HOLIDAY	16
17	18 HOLIDAY	19 Rafael Cantu Junior High School (8:00 am – 11:00 am) Midkiff Elementary (1:00 pm – 4:00 pm)	20 Waitz Elementary (8:00 am – 11:00 am) Escobar - Rios Elementary (1:00 pm – 4:00 pm)	21 Veterans Memorial High School (8:00 am – 11:00 am) (1:00 pm – 4:00 pm)	22 Mission Junior High School (8:00 am – 11:00 am) Bryan Elementary (1:00 pm – 4:00 pm)	23
24	25 O'Grady Elementary (8:00 am – 11:00 am) Kenneth White Junior High School (1:00 pm – 4:00 pm)	26 Pearson Elementary (8:00 am – 11:00 am) Leal Elementary (1:00 pm – 4:00 pm)	27 Mims Elementary (8:00 am – 11:00 am) Marcell Elementary (1:00 pm – 4:00 pm)	28 Mission High School (8:00 am – 11:00 am) (1:00 pm – 4:00 pm)	29 Roosevelt Alternative/Options (8:00 am – 11:00 am) Castro Elementary (1:00 pm – 4:00 pm)	30



Thank you!

Annual Compliance Announcement of Board of Trustees' Continuing Education Credit (CEC) Hours for:

Mr. Jerry Zamora
Mrs. Veronica R. Mendoza
Mr. Roy Vela
Mrs. Minnie Rodgers
Mrs. Petra Ramirez
Mrs. Iris Iglesias
Mr. Juan Gonzalez

Have completed and or exceeded the required continuing education hours. All Board members have met or exceeded their requirements for the continuing education hours requirements for the year 2021-2022.

SUBJECT: Discussion and Approval of Purchase of Veterans Memorial High School Marching Band Uniforms

PRESENTER: Dr. Sharon Roberts, Deputy Superintendent for Curriculum and Instruction

BACKGROUND INFORMATION

Veterans Memorial High School Band is in need of new marching band uniforms. The style and scheme of the current uniform is out date and does not lend itself to the contemporary theme and look of today's marching bands in the state of Texas. The presentation of the uniform is as important to the success of the program as is the musical performance. The sport of marching band has become a very competitive event so it is essential to maintain and stay up to date with current trends for uniforms. A life expectancy for a marching uniform is 7 years due to wear and tear (contests, games, parades, public events etc.), therefore the VMHS band is due for replacement of uniforms since their current uniforms were ordered in 2015.

ADMINISTRATIVE CONSIDERATIONS

This purchase will be made using Inter-local Purchasing Co-op. Using an Inter-local Purchasing Co-op complies with purchase requirements of TEC 44.031a(4) and local board policy requiring an approved purchasing method for contracts valued at \$50,000 or more.

FUNDING SOURCE AND AMOUNT

General Fund – Fine Arts Budget

Estimated Expenditure: \$145,000

RECOMMENDATION:

Administration will bring a recommendation to award the contract to the April 13th Board Meeting.

CONTACT PERSON(S)

Dr. Sharon Roberts, Deputy Superintendent for Curriculum and Instruction
Joel Garcia, Assistant Superintendent for Finance
Carlos Garcia, Fine Arts Director
Dora Garcia, Purchasing Coordinator

SUBJECT: Consideration and Approval to Accept Best and Final Offer (BAFO) for Supplemental Repairs (Visitors Side) for the Tom Landry Stadium Repairs Project – Ricardo Hinojosa Engineering, Inc.

PRESENTER: Ricardo Rivera
Assistant Superintendent for Operations

BACKGROUND INFORMATION

STADIUM:

Tom Landry Stadium was built in approximately 1976 and additional seating was installed in approximately 1989. It currently has only four (4) handicap seating spaces on both the home and visitors' side. The home side has a seating capacity for 5000 persons and the visitor's side has a seating capacity for 4000 persons.

At the Regular Board of Trustees meeting held on Wednesday, August 11, 2010 the Board approved a structural assessment to be conducted by Rick Hinojosa Structural Engineering. A report was completed on August 27, 2010. No further action was taken.

At a football game on September 26, 2013 and at the Regular Board of Trustees meeting of Wednesday, October 09, 2013, a concerned citizen brought to attention the fact that Tom Landry Stadium was not in compliance with the American Disabilities Act (ADA) current code concerning the required handicap seating spaces. As per ADA the breakdown for seating is 6 spaces for 1 – 500 seats then 1 seat for every 150 additional seats. As per calculations required additional seating on the home side will be 36 ADA seats and, on the visitors, side will be an additional 30.

On October 08, 2013 I contacted Mr. Tim Petty, Program Specialist V with the Texas Education Agency (TEA) to discuss this issue and he confirmed that we were not in compliance with current codes and standards concerning stadium seating.

At the Regular Board of Trustees meeting held on Wednesday, December 11, 2013 and after consultation with our legal counsel, the Board approved for renovations to the Tom Landry Stadium Press Box and for the additional required ADA stadium seating.

The current press box is approximately 30 years old and has never been renovated. When new bleacher seating was installed the press was moved by crane to its current location. With the installation of a new scoreboard additional staff will need to be placed in the press box to operate the system. Currently approximately nine persons are in the box, however, it is now estimated that up to twenty-two persons may be in the box at any given time. This added weight along with the additional weight of chairs and equipment may cause a stress on the structure. As per our legal counsel, there is no legal law that states that the structure needs to be evaluated, however, for safety precautions Administration is considering a structural assessment study to be conducted on the press box to ensure that the structure is capable of sustaining the additional weight.

At the Regular Board of Trustees meeting held on Wednesday, March 20, 2013 Administration presented and the Board approved Consideration and Approval to Contract with Rick Hinojosa Engineering for a Re-Assessment of the Tom Landry Stadium Press Box.

At the Regular Board of Trustees meeting held on Wednesday, April 10, 2013 the Board was advised that due to concerns and possible code regulations requiring an elevator to be installed for the press box, inquiries were made to Mr. David Hansen, Legal Counsel. As per building code an elevator is required should the square footage of a press box be larger than 500 sq. ft. Our current press box is approximately 40' X 8' which is 320 sq. ft.. However, should only renovations be required without the addition of sq. footage the initial structural assessment will need to be considered. Furthermore, it is the responsibility of the structural engineer to make the decisions of what is currently within building codes and regulations even if it is only renovations. The possible recommendation of constructing adjacent press boxes may still require an elevator to be installed. The sq. footage requirement applies to the "aggregate" total sq. footage of all press boxes. Again, it will be the responsibility of the structural engineer to make that determination. Renovations to include floor support, the construction of an interior wall, counter tops, sliding windows.

At the February 05, 2014 Facilities Committee meeting, a presentation by Rick Hinojosa Structural Engineering stated that current plans to improve the press box must include the installation of an elevator or a ramp access to the press box as per the State of Texas current code. At this meeting the committee decided to cancel the press box renovation project.

At the Special Board of Trustees Meeting held on Wednesday, April 20, 2016, the Board approved the following:

Administration is again exploring the possibility of a stadium renovation to include a new press box, new reserve section seating with back rests, new concession stands, new concrete base under the bleachers along with new bleachers to meet current ADA rules and regulations. New bleachers to also include those at Leo Najó Baseball Park.

Administration is requesting approval to advertise for Request for Qualifications (RFQ's) for architectural/civil engineer services as the recommended process for the selection.

The ranking of Request for Qualifications responses must be on the basis of demonstrated competence, qualifications, capability to perform, the past performance of the firm and members of the firm, and other appropriate factors submitted by the firm in response to the request for qualifications, except that cost-related or price related evaluation factors are not permitted as provided by Section 2254.004, Government Code.

If approved, Administration will begin advertising for architects and then begin the process of reviewing the firms as per the RFQ's and schedule presentations for the Board to review and possibly select a firm.

Advertisements for Request for Qualifications (RFQ's) for architects were advertised in the local newspaper on Wednesday, June 1st and June 8th, 2016 along with being posted on the MCISD website. RFQ's were due at Central Office on Thursday, June 23, 2016 at 2:00 p.m...

Three (3) architectural firms submitted an RFQ and they were reviewed for completeness and adherence to the instructions of the request by Mr. Roosevelt Rios, Purchasing Coordinator and Ms. Tammy Tijerina, Project Manager on Thursday, July 28, 2016. The firms are listed below:

PBK Architects GIGNAC &
Assoc.
Alvarado Architects

This agenda item and presentation(s) were originally scheduled for Wednesday, August 03, 2016, however, they were postponed for a later date and time.

At the Facilities/Environment Committee held on Wednesday, August 24, 2016, the three ranked firms were invited to make a presentation to a Special Facilities/Environment Committee meeting and those Board members in attendance. The Committee allowed the firms a 15-minute presentation session along with a 15-minute question and answer session. The Committee along with Mr. Ricardo Rivera evaluated and ranked the firms on the basis of demonstrated competence and qualifications pursuant to the Professional Services Procurement Act as per the presentations. The rankings were then presented at the Special Board of Trustees meeting for consideration and approval for the selection of services.

At the Special Board Meeting held on Wednesday, August 24, 2016, the Board approved the rankings and selection of Alvarado Architects for services for the Tom Landry Stadium Renovations Project.

At the Regular Board Meeting held on Wednesday, September 14, 2016, the Board approved the contract for Alvarado Architects for the Tom Landry Stadium Renovations Project.

At the Regular Board Meeting held on Wednesday, November 09, 2016, the Board approved the project and budget, the procurement method and Alvarado Architects request of Schematic Design and Design Development for the Tom Landry Stadium Renovations Project. Alvarado Architects, District Staff and Coaches have been working on the design due to the extremely tight timeline, this project has to be completed by late July 2017. Current design will have new concession stands, new parking, new parking over-lay where needed, concrete area below home side, new stadium fascia, new complete seating bleachers at both home and visitor side, home side reserved seating to have back rests, seating and ramps to be ADA compliant, new ticket booths, press box with elevator as recommended design, new stadium lighting as required along with other required items needed for the project.

At the Regular Board meeting held on Wednesday, December 14, 2016, the Board approved Alvarado & Associates final design and Approval for 24-inch-Wide Seats in the Reserved Section for the Tom Landry Stadium Renovations Project.

Advertisements in the local newspapers and at the Association of General Contractors Office (AGC) were posted on December 18, 2016 and December 25, 2016 for the new design. A pre-proposal meeting was held on Tuesday, January 10, 2017 at 2:00 P.M. at Central Office.

Proposals were publicly opened on Tuesday, January 17, 2017 at 4:00 P.M. at Central Office. Pre-ranking of the proposals were conducted by Mr. Roosevelt Rios, Mr. Albert Rodriguez and Mr. Adrian Hernandez, Project Manager on Tuesday, January 17 and Wednesday, January 18, 2017.

At the Facilities Committee meeting the Committee reviewed the pre-ranking of firms and then proceeded to officially rank the firm's proposals. These rankings will then be presented to the Board of Trustees for consideration and approval for entering into negotiations in the order of ranking recommended at a special called meeting on Monday, January 23, 2017 at 7:30 a.m.

Pre-ranking of proposals by Administration is merely a district process to pre-check if all requested documents and information in the Request for Proposals (RFP) was submitted prior to the Evaluation and Selection Committee formal evaluation. The pre-ranking of proposals is strictly unofficial. The Request for Proposal (RFP) package includes document CSP – 00350 Evaluation and Selection Criteria for Competitive Sealed Proposals which defines this portion of the procurement process. The District Evaluation and Selection Committee is comprised of three (3) Board of Trustees Facilities Committee Members and one (1) appointed Administration Staff. The Evaluation and Selection Committee will evaluate, rank and publish all proposals. The Evaluation and Selection criteria has been approved by the Mission C. I. S. D.'s Board. Once the M. C. I. S. D. Board of Trustees approves the ranking, the District Evaluation and Selection Committee will then proceed to negotiate a contract with the highest-ranking Proposer.

The Finance department in conjunction with the districts finance consultants have been designing a funding package for this project. In order to ensure this project under this funding source be securely financed Administration is recommending to adjust the contingency budget by an increase of \$2 million. Thus, the total construction budget to include all soft-costs will not exceed \$10 million.

Three proposals were submitted for this project and were ranked by the Facilities Committee as per MCISD guidelines and procedures. The Board must now consider the rankings and approve to enter into negotiations with the top ranked firms in the order selected. Rankings listed below:

<u>Company</u>	<u>Base Proposal</u>	<u>Alt. #1</u>	<u>Days</u>
Holchemont Const. (291)	\$7,463,000.00	(\$287,000.00)	235
E-Con Const. (287.6)	\$7,450,000.00	\$210,000.00	180
Central Builders (260.2)	\$8,000,000.00	\$500,000.00	180

Note:

Alternate #1 is for a larger custom-built press box of which Administration recommends approving. Both E-Con Construction and Central Builders have an additional cost for this alternate, as per Holchemont Construction their base bid includes the larger custom press box. Should MCISD select the smaller pre-fabricated press box Holchemont has a \$287,000.00 deduct from their base bid. The intention is for a notice to proceed (NTP) to be issued on or before February 01,³⁵2017 with a substantial completion date of July 31,

2017, which is 180 days, Holchemont has a substantial completion date of September 24, 2017. Proposals and days are all prior to negotiations.

At a Special Board of Trustees meeting to be held on Monday, January 23, 2017, the Board will consider and possibly approve the rankings to allow negotiations to begin. It is Administrations intent to bring forward at the Regular Board of Trustees meeting to be held on Wednesday, January 25, 2017 an approval and recommendation for a best and final offer (BAFO) and to enter into contract with the selected general contractor. It is MCISD's construction procurement process to present all items for Facilities Committee discussion prior to presenting to the Board of Trustees for final approval.

At the Regular Board of Trustees meeting held on Wednesday, January 25, 2017, the board approved the best and final offer (BAFO) from Holchemont in the amount of \$7,463,000.00 with alternate #01 custom press box included as part of the contract. Notice to proceed (NTP) was issued on February 02, 2017 with a substantial completion date of August 21, 2017.

At the Regular Board of Trustees meeting held on Wednesday, April 12, 2017, the board approved and pulled the following items:

Consideration and Approval of AEA #01 for CPR #02 to Furnish and Install Sports Lighting for the Tom Landry Stadium Renovations Project.

Sports Lighting Allowance:	\$600,000.00
AEA#01 Sports Lighting:	<u>\$580,392.00</u>
Balance:	\$ 19,608.00

Consideration and Approval of AEA #02 for CPR #03 to Furnish and Install a Scoreboard Sound System for the Tom Landry Stadium Renovations Project. Item was pulled for further pricing on additional speakers throughout the stadium.

Consideration and Approval of AEA #03 for CPR #04 to Furnish and Install Football Safety Netting System for the Tom Landry Stadium Renovations Project. Item was pulled due to MCISD having the netting and poles and only required pricing for the installation.

Consideration and Approval of AEA #04R to "Credit" the Allowances for the Tom Landry Stadium Renovations Project. Item was pulled due to other items being pulled thus not being able to present an accurate balance total.

Consideration and Approval of CPR #06 to Change the Size of the Bronze Statue for the Tom Landry Stadium Renovations Project.

Bronze Statue Allowance:	\$ 50,000.00
CPR#06 Bronze Statue:	<u>\$129,400.00</u>
Bronze Statue Allowance Balance:	(\$ 79,400.00)

Due to inclement weather in the month of March Holchemont Construction requested additional delay days, thus, they presented Consideration and Approval of CPR #09 for Seven (7) Delay Days for the Tom Landry Stadium Renovations Project. The new substantial completion date is August 28, 2017.

Administration presented Consideration and Approval of Selection of Color and Pattern for the Reserved Seating on Home Side for the Tom Landry Stadium Renovations Project. The Board approved option #1 alternating colors.

At the Regular Board of Trustees meeting held on Wednesday, May 10, 2017, the Board approved and pulled the following items:

Contingency Allowance:	\$100,000.00
AEA #01 Sports Lighting:	\$ 19,608.00
CPR #6 Bronze Statue:	<u>\$ (79,400.00)</u>
Contingency Balance:	\$ 40,208.00

Consideration and Approval of AEA #03R for CPR #04 to Furnish and Install Football Safety Netting System for the Tom Landry Stadium Renovations Project.

Football Safety Net System Allowance:	\$10,000.00
AEA#03 Football Safety Net System:	<u>(\$ 7,500.00)</u>
Balance:	\$ 2,500.00

Consideration and Approval of CPR #08 to Construct a Riser Room / Fire Pump for the Tom Landry Stadium Renovations Project.

Fire Suppression Pump Allowance Balance:	\$ 50,000.00
CPR # 08 Riser Room:	<u>\$ 110,428.53</u>
Balance:	(\$ 60,428.53)

Contingency Balance:	\$40,208.00
CPR #8 Riser Room:	(\$60,428.53)
Plus, Overhead and Profit	<u>(\$2730.47)</u>
Contingency Balance:	(\$22,951.00)

Due to inclement weather in the month of April and MCISD testing Holchemont Construction requested additional delay days, thus, they presented Consideration and Approval of CPR #09 for Eight (8) Additional Delay Days for the Tom Landry Stadium Renovations Project. The new substantial completion date is September 05, 2017.

Note: The first scheduled football game is for Friday, September 01, 2017 with VMHS vs Harlingen. Substantial completion is granted when the facility can be utilized for its intended use. The City of Mission Fire Marshal must approve the facility to include all fire systems are inspected and tagged "approved" along with all ADA inspections and approvals and to include the inspection and approval of the elevator system and to include any other inspections required. Coaches are working on a Plan "B" should the stadium not be completed on time.

Administration recommended Consideration and Approval of Re-naming for the Tom Landry Stadium Renovations Project as "Tom Landry Hall of Fame Stadium".

Administration recommended Consideration and Approval of Selection of Color for Reserved Seating on Home Side for the Tom Landry Stadium Renovations Project.

Recommendation is based on the colors selected by Coach Detmer, Coach Gilpin, Athletic Director Joe Sanchez and Athletic Director Leticia Ibarra.

Royal Blue
Texas A&M – Maroon

After a lengthy discussion on possible color dis-coloration of the royal blue and maroon seats the Board approved “grey” for the reserved seating.

Alvarado Architects presented a “pose” selection on the statue. At the Facilities Committee meeting held on Wednesday, May 03, 2017, the Committee along with members of the Campus Construction Over-Sight Committee members reviewed and discussed the five (5) options of poses brought forward by Mr. Alvarado. By virtue of the discussion and by show of hands, options #1 and #4 were selected for presentation to the Board. The Board approved Consideration and Approval of Tom Landry Statue Pose for the Tom Landry Stadium Renovations Project Option #1.

At the Facilities/Environment Committee meeting held on Wednesday, June 07, 2017 several CPR’s were presented and discussed. These CPR’s may become change orders should current available allowances not cover the over-budget of the project when it is finalized. MCISD Administration stressed to Alvarado Architects and Holchemont Construction the discontent of change orders and requests for additional construction time. Administration stressed the importance of having the project completed as per the original substantial completion date.

At a Special Board of Trustees meeting held on Wednesday, June 07, 2017, the Board granted Superintendent Dr. Ricardo Lopez authority to approve change orders/change proposal request for the Tom Landry Stadium Renovations Project in the amount not to exceed a total of \$250,000.00. This action was to facilitate the change order/CPR process and not delay the general contractor waiting for a decision.

The following Change Orders/CPR’s were approved by Superintendent Dr. Ricardo Lopez on Wednesday, June 07, 2017:

Supt. Approval Balance:	\$250,000.00
CPR#05R Structural Steel:	\$ 31,824.00
CPR#06R Bronze Statue Foundation:	\$ 12,161.00
CPR#11 for MEP changes at the Press Box:	\$ 8,674.00
CPR#14 for HVAC at the Gift Shop:	\$ 12,268.00
CPR#19 for Additional Gates for Eagle Drive:	<u>\$ 1,816.00</u>
Supt. Approval Balance:	\$183,257.00

Consideration and Approval of CPR#05R for Structural Steel between Grandstands and Custom Press Box for the Tom Landry Stadium Renovations Project.

Contingency Balance: 38 (\$22,951.00)

Structural Steel Additions Cost: \$31,824.00
Contingency Balance: (\$54,775.00)

Consideration and Approval of CPR#06R for Bronze Statue Foundation and Base for the Tom Landry Stadium Renovations Project.

Contingency Balance: (\$54,775.00)
Bronze Statue Base Foundation Cost: \$12,131.00
Contingency Balance: (\$66,906.00)

Consideration and Approval of CPR#11 for MEP changes at the Press Box for the Elevator for the Tom Landry Stadium Renovations Project. Holchemont, LTD is requesting eight (8) additional day, if approved, the new substantial completion date is September 13, 2017. As per Alvarado Architects additional days will not be submitted.

Contingency Balance: (\$66,906.00)
Electrical at press box Cost: \$ 8,674.00
Contingency Balance: (\$75,580.00)

Consideration and Approval of CPR#14 for HVAC at the Gift Shop for the Tom Landry Stadium Renovations Project.

Contingency Balance: (\$75,580.00)
HVAC at gift shop Cost: \$12,268.00
Contingency Balance: (\$87,848.00)

Consideration and Approval of CPR#19 for Additional Gates for Eagle Drive for the Tom Landry Stadium Renovations Project

Contingency Balance: (\$87,848.00)
Gates at Eagle Drive Cost: \$ 1,816.00
Contingency Balance: (\$89,664.00)

At the Regular Board of Trustees meeting held on Wednesday, June 21, 2017, The Board did not approve Consideration and Approval of CPR#20 for Additional Four (4) Rain Days for the Month of May for the Tom Landry Stadium Renovations Project.

*Note: After meeting with Alvarado Architects and Holchemont LTD, they were advised that Administration will be questioning any further delay days submitted and that Holchemont should continue working on a recovery schedule plan to attempt to bring this project at the initial substantial completion date of August 21, 2017.

The following Change Orders/CPR's were approved by Superintendent Dr. Ricardo Lopez on Thursday, June 29, 2017 in order to have the project continue without contractor delays:

Supt. Approval Balance Granted: \$183,257.00
CPR#12 Track Timing System: \$ 45,322.00
Supt. Approval Balance: 39 \$137,935.00

Change Order Amount to Date: (\$134,986.00)

Note: General Contractor has added 12% overhead and profit and 1.5% for project bonding on all change order amounts.

Soil Stabilization Allowance:	\$10,000.00
CPR #16 Soil Stabilization:	<u>\$10,000.00</u>
Balance:	\$ 0.00

Utility Allowance:	\$20,000.00
CPR #21 Boring & Trenching:	<u>\$16,830.00</u>
Balance:	\$3,170.00

At the Special Board of Trustees Meeting to be held on Thursday, July 27, 2017, Administration presented to the Board Consideration and Approval of CPR#15 for Graphics for the Tom Landry Stadium Renovations Project. This amount is to be taken from the graphics allowance already included in the original contract.

Graphics Allowance Balance:	\$100,000.00
Banner system:	(\$ 51,148.50)
Identification signage:	(\$ 26,815.00)
Bleacher section signage:	(\$ 13,625.00)
Traffic signage:	(\$ 2,136.00)
Fire lane striping:	<u>(\$ 3,700.00)</u>
Balance:	\$ 2,575.50

At the Regular Board of Trustees meeting held on Wednesday, August 09, 2017, the Board considered and approved some of the following items:

As per our Legal Counsel, the Board did not need to vote on agenda item, Consideration and Approval of Additional Seven (7) Delay Days for AEA#11 for CPR #21 for the Tom Landry Stadium Renovations Project which was previously denied but being brought forward by Holchemont, LTD. once again for consideration. The Board had stated it would possibly revisit this request and no action was taken.

Consideration and Approval of AEA#12 for CPR #22 for Landscaping and Irrigation for the Tom Landry Stadium Renovations Project.

Landscape/Irrigation Allowance:	\$20,000.00
CPR#22 Landscape & Irrigation:	<u>\$17,383.00</u>
Balance:	\$ 2,617.00

Consideration and Approval of AEA#13 for CPR #24 to Up-grade the Scoreboard System for the Tom Landry Stadium Renovations Project.

Scoreboard Sound System Allowance:	\$55,000.00
CPR#24 Scoreboard System:	<u>\$34,934.00</u>
Balance:	40 \$20,066.00

Consideration and Approval of CPR #23 for Speaker System for the Tom Landry Stadium Renovations Project. This agenda item was pulled.

At the Regular Board of Trustees meeting held on Wednesday, September 13, 2017, the Board revisited and approved Consideration and Approval of Additional Seven (7) Delay Days for AEA#11 for CPR #21 for the Tom Landry Stadium Renovations Project. As of the date of this Board of Trustees meeting Holchemont LTD will be into possible liquidated damages as per contract of \$1,500.00 per day of not meeting the substantial completion date. Administration brought forward this request, the new substantial completion date is September 12, 2017.

At the Regular Board of Trustees meeting held on Wednesday, October 11, 2017, the Board took the following actions for the following items:

Consideration and Approval of CPR #12R3 for Additional Power for the Tom Landry Stadium Renovations Project. Please note that Holchemont, LTD will require and extra four (4) days. If approved, the new substantial completion date is September 16, 2017. This item was pulled until further review.

Note: MCISD does not agree with this pricing, however, there will be a cost associated with installing conduits within the concrete slab which was done earlier. If the revised pricing is not approved MCISD Maintenance will complete the electrical connections.

Contingency Balance:	(\$134,986.00)
CPR#12R3 for Additional Power:	\$ <u>0.00</u> (Org. price \$10,134.42)
Change Order Amount to Date:	(\$134,986.00)

Consideration and Approval of CPR #12R5 for Additional Cabling for Track Timing System for the Tom Landry Stadium Renovations Project. Please note that Holchemont, LTD will require and extra fourteen (14) days. If approved, the new substantial completion date is September 30, 2017. This item was pulled until further review.

Contingency Balance:	(\$134,986.00)
CPR#12R5 Additional Cabling:	\$ <u>0.00</u> (Org. price \$54,468.65)
Change Order Amount to Date:	(\$134,986.00)

Consideration and Approval of CPR #17 to "Credit" Two (2) Wireless Access Points, Shortel Phone and Video Server for the Tom Landry Stadium Renovations Project. This item was approved.

Contingency Balance:	(\$134,956.00)
CPR#17 "Credit" on Technology:	\$ <u>5,000.00</u> "Credit"
Change Order Amount to Date:	(\$129,986.00)

Consideration and Approval of CPR #18 to "Credit" Fire Alarm and Intrusion Systems for the Tom Landry Stadium Renovations Project. This item was approved.

Contingency Balance:	(\$129,986.00)
CPR#18 "Credit" Fire Alarm System:	<u>\$ 2,800.00</u> "Credit"
Change Order Amount to Date:	(\$127,186.00)

Consideration and Approval of CPR #25 to Relocate Cross Bracing at Concession Stands for the Tom Landry Stadium Renovations Project. This item was approved with the cost change to \$5,221.00

Contingency Balance:	(\$127,186.00)
CPR #25 to Relocate Cross Bracing:	<u>(\$ 5,221.00)</u> (Org. price \$10,442.00)
Change Order Amount to Date:	(\$132,407.00)

Consideration and Approval of CPR #26 to Remove and Replace Concrete from the Ramps for the Tom Landry Stadium Renovations Project. Please note that Holchemont, LTD will require and extra two (2) days. If approved, the new substantial completion date is October 2, 2017. This item was pulled, Javier Hinojosa Civil Engineer will take care of this item.

Contingency Balance:	(\$132,407.00)
CPR #26 to Remove and Replace Concrete:	<u>\$ 0.00</u> (Org. price \$4,483.25)
Change Order Amount to Date:	(\$132,407.00)

Consideration and Approval of CPR #27 to Add IDF Rack, Quad Receptacles and Data Drops on the Visitor's Side Bleachers for the Tom Landry Stadium Renovations Project. Please note that Holchemont, LTD will require and extra three (3) days. If approved, the new substantial completion date is October 5, 2017. This item was pulled, MCISD will take care of this item.

Contingency Balance:	(\$132,407.00)
CPR #27 to Add IDF Rack:	<u>\$ 0.00</u> (Org. price \$18,357.49)
Change Order Amount to Date	(\$132,407.00)

Consideration and Approval of CPR #29 for Additional Eleven (11) Delay Days for the Tom Landry Stadium Renovations Project. If approved, the new substantial completion date is October 16, 2017 pending all other CPR's being submitted. The Board took no action on this item.

Consideration and Approval to Grant Administration Authority to Approve Substantial Completion for the Tom Landry Stadium Renovations Project. Dr. Lopez, Superintendent will have the authorization. This item was approved.

Note: No additional delay days were approved at this meeting. Substantial completion continues to be approximately September 12, 2017.

At the Regular Board of Trustees meeting held on Wednesday, November 08, 2017, the Board took the following actions for the following items:

Consideration and Approval of CCD#01 for CPR#30 for Modifications to the Elevator Equipment Room for the Tom Landry Stadium Renovations Project. No additional days were approved.

Contingency Balance:	(\$132,407.00)
CCD#01/CPR#30 Elevator Equipment Room:	<u>\$ 3,957.00</u>
Change Order Amount to Date	(\$136,364.00)

Consideration and Approval of CPR#31 to "Credit" for Use of Owners Utilities for the Tom Landry Stadium Renovations Project. MCISD presented a "credit" for \$5,900.00, however, Holchemont offered only a credit amount of \$900.00.

Contingency Balance:	(\$136,364.00)
CPR#31 Use of Owners utilities:	<u>\$ 5,900.00</u> "Credit"
Change Order Amount to Date:	(\$130,464.00)

Consideration and Approval of CPR#32 for HVAC Test and Balance for the Tom Landry Stadium Renovations Project.

Test and Balance Allowance:	\$5,000.00
CPR#32 HVAC Test & Balance:	<u>\$2,500.00</u>
Balance:	\$2,500.00

Consideration and Approval of CPR#33 for Two (2) Additional Fire Extinguishers for the Tom Landry Stadium Renovations Project.

Contingency Balance:	(\$130,464.00)
CPR#33 Fire Extinguishers:	<u>\$ 268.00</u>
Change Order Amount to Date	(\$130,732.00)

At the Regular Board of Trustees meeting held on Wednesday, December 13, 2017, the Board took the following actions for the following items:

Consideration and Approval of CPR #12R3 for Additional Power for the Tom Landry Stadium Renovations Project. This item was approved.

Contingency Balance:	(\$130,732.00)
CPR#12R3 additional power:	<u>\$ 6,327.00</u>
Balance:	(\$137,059.00)

Consideration and Approval of CPR#34 for "Credit" for the VIP Chair Allowance for the Tom Landry Stadium Renovations Project. VIP Chair Allowance "Credit" is \$5000.00. This item was approved.

Discussion and Possible Action on Paving Repair Schedule for the Tom Landry Stadium Renovations Project.

Consideration and Approval for Final Completion, Less Betterment Fund Allowance and Final Payment, Less Liquidated Damages for the Tom Landry Stadium Renovations Project. This item was pulled due to punch list items and other contractual obligations were noncompliance.

At the Regular Board of Trustees meeting held on Wednesday, April 11, 2018 the Board took the following actions for the following items:

Consideration and Approval of CPR#23 for Sound System Raceways for the Tom Landry Stadium Renovations Project. Holchemont LTD is requesting fourteen (14) additional delay days for this work, if approved the new substantial completion date is September 26, 2017.

Contingency Balance:	(\$137,059.00)
CPR#23 for Sound System:	<u>\$ 39,839.37</u>
Balance:	(\$176,898.37)

Consideration and Approval of Grievance Agreement for Use of Owners Utilities for the Tom Landry Stadium Renovations Project. As per the November approved CPR #31, MCISD approved an owner's credit for utility use of \$5,900.00. As per grievance agreement the amount was reduced to \$2,350.00, thus an adjustment needed to be made.

Previous: \$5,900.00
Final approved as per Grievance: \$2,350.00
Adjustment: \$3,550.00

Contingency Balance:	(\$180,448.37)
----------------------	----------------

Discussion and Possible Legal Action Regarding Parking Lot Repairs for the Tom Landry Stadium Renovations Project. At this time the Board invoked the "Self Help Provision" of the contract authorizing Administration to make necessary parking lot repairs utilizing a different contractor.

2GS and Earthworks re-paving Cost: \$24,700.00 - Parking Lot Re-paving completion date was achieved on August 06, 2018.

Fall 2017 - Spring 2019 items continued to be repaired and discussed.

After conducting field reviews and inspections Mission CISD contracted with Rick Hinojosa Structural Engineering to conduct a third party Visual Cursory Observation on the bleachers for the visitor's side of Tom Landry Stadium. On September 06, 2018 the observation report with conclusions and recommendations was submitted. In brief, Hinojosa stated that the cracked piers did not affect the immediate load carrying capacity of the structure and the stadium could be used. However, the recommendations were to conduct a complete assessment of all piers and repair all necessary items addressed in the complete assessment.

February 12, 2019 MCISD and Rick Hinojosa Structural Engineering entered into a contract for a full stadium assessment.

At the Regular Board of Trustees meeting held on Wednesday, May 08, 2019, the Board took no action on the following item: Consideration and Approval for Final Completion, Less Betterment Fund Allowance and Final Payment, Less Liquidated Damages for the Tom Landry Stadium Renovations Project. At this meeting Administration also recommended to authorize Administration and Dr. Perez to approve final completion at a later time, this was rejected with direction from the Board that they wanted this brought forward when the time came for consideration and approval.

At the Regular Board of Trustees meeting held on Tuesday, June 11, 2019 the Board took the following actions

Administration, Mr. Eli Alvarado, Architect, and Mr. Michael Montalvo, General Contractor have met six times since April 25, 2019 with the latest meeting held on Tuesday, June 04, 2019, to discuss what is required from all parties to bring this project for final recommendation and to possibly come to a mutual agreement and present to the Board of Trustees Consideration and Approval for Final Completion, Less Betterment Fund Allowance and Final Payment, Less Liquidated Damages for the Tom Landry Stadium Renovations Project. At the latest meeting Mr. Montalvo was not able to attend and for many of these meetings Dr. Perez, Superintendent was present. A 1 ½ year warranty project walk-through was conducted as per contract specifications on Friday, May 03, 2019 with Mr. Alvarado, his design staff, Mr. Montalvo, his sub-contractors and MCISD personnel present to identify any warranty items that are still pending and need correction. The meetings that are being conducted are to balance and agree on all financial/accounting matters and pending correction of work if applicable. Any matters that concern additional request for time or matters that may concern any deduction from the remaining balance owed to the contractor such as additional fees/costs or possible liquidated damages incurred the general contractor will need to follow the process as written in his contract.

As noted, Administration and Alvarado Architects believes it has tried, with due diligence, to work on all pending accounting/fiscal matters with Mr. Montalvo, however, we continue to not agree on a mutual amount. Administration presents Discussion with Legal Counsel Regarding Closeout for the Tom Landry Stadium Renovations Project with MCISD processing any possible pay applications to Holchemont Construction with monies being withheld that are not in contention.

Note: Additional structural assessment is continuing by Rick Hinojosa, Structural Engineering and is pending completion. They are pending additional concrete test results.

Tom Landry Stadium Project Timeline:

Notice to Proceed (NTP) – 02/01/2017

Original Substantial Completion Date – 08/21/2017

36 delay days Board approved due to testing, weather, change orders

New substantial completion date – 09/26/2017

Approved substantial completion date – 11/10/2017 (45 days late)

Original Final Completion Date – 12/10/2017

New Final Completion Due Date – 04/20/2018 (131 days late) **NEVER APPROVED**

Possible LD's for not meeting Subst. Completion: 45 days X \$1,500.00 = \$67,500.00

Possible LD's for not meeting Final Completion: 131 days X \$500.00 = \$65,500.00

Possible LD's for delay in re-paving of parking lot: 7 days x\$500.00 per day = \$3,500.00

Possible LD's Incurred: \$136,500.00

Other Possible Fees/Costs:

Re-paving of parking lot = \$24,700.00

Structural Engineering cursory inspection = \$5,000.00 (Rick Hinojosa, Structural Engineering)

Hinojosa full structural assessment = \$30,000.00 (if applicable)

TDLR re-inspections = \$285.00

Terracon Structural additional services = \$15,000.00

Pending "credit" for three (3) parking lot poles not installed = \$53,489.08

Approximate Possible Total Amount of addtl. fees/costs: \$128,474.08

Additional Architect Fees: \$85,695.00 (if applicable/pending)

Balance on contract:	\$416,406.11
Possible LD's:	\$136,500.00 Possible
addtl. Costs:	\$128,474.08
Possible addtl. Arch. Fees:	\$ 85,695.00
Paid Holchemont:	\$ 43,189.25 (07/24/19 Pay App. #10 rev.3)

Est. Current Balance on Contract: ~~\$380,251.23~~ as of 04/21/2021 \$347,206.23

Est. Construction Costs: \$6,000,000.00

Est. Total Construction w/Soft Costs: \$8,000,000.00

BAFO Const. Cost: \$7,463,000.00

Change Orders: \$ 142,020.37

Final Const. Cost: \$7,605,020.37

Architect Fees: \$485,095.00 6.5% of Construction Cost

Addtl. Arch. Fees for C/O's: \$9,231.32

Architect Fees: \$494,326.32 (excluding addtl. Fees pending)

At the Regular Board of Trustees meeting held on Wednesday, August 14, 2019 the Board took the following actions.

At this meeting the Mr. Rick Hinojosa Structural Engineering Assessment report was not available for the Board of Trustees to review, however, Administration had preliminary verbal discussions with Hinojosa on what he was to submit, the report was to be finalized on Friday, August 16, 2019. Should the report state that repairs were required

Administration presented Consideration and Possible Action Regarding Procurement of Design and Construction Services for the Tom Landry Stadium Repairs in advance.

Administration was approved to contract with Hinojosa to conduct a full stadium assessment to include not only concrete piers but to inspect the entire structure of the stadium. On August 08, 2019, Hinojosa Engineering submitted a preliminary assessment letter for our review noting possible reinforcement required.

On August 16, 2019, Hinojosa Structural Engineering submitted their Visual Structural Condition Assessment of Tom Landry Stadium for our review.

At the September 11, 2019 Regular Board of Trustees meeting and based on Mr. Hinojosa's report, Administration presented Consideration and Approval of Design and Construction Services for the Tom Landry Stadium Repairs.

The Board of Trustees must take the necessary action in accordance with Texas Education Code 44.035 which consisted of the selection/designation of an architect and/or engineer to prepare construction documents for this project. The engineer and/or architect selected or designated will have full responsibility for complying with the Texas Engineering Practice Act (Article 3271a, Vernon's Texas Civil Statutes) or Chapter 478, Acts of the 45th Legislature, Regular Session, 1937 (Article 249a, Vernon's Texas Civil Statutes) as applicable.

If the engineer or architect is not a full-time employee of the District, the Board must select the engineer or architect on the basis of demonstrated competence and qualifications as provided by Section 2254.004, Government Code. The selected architect/engineer along with preparing construction documents will be required to provide MCISD with an estimated project budget.

Current and/or past structural engineers that have worked with MCISD are listed below, the Board of Trustees may select from one of these engineers on the basis of demonstrated competence and qualifications or may direct Administration to seek for Request for Qualifications (RFQ's) on an engineer or architect.

Rick Hinojosa Structural Engineering (conducted assessments)
Chanin Structural Engineering (original project structural engineer)

The Board of Trustees selected Mr. Rick Hinojosa Structural Engineering to conduct a thorough third-party structural assessment of the Tom Landry Stadium Project.

On or about January 27, 2020, Mr. Hinojosa submitted to Administration a proposal for forensic engineering services from MEG Engineers. The Forensic Engineering Services will include Ground Penetrating Radar (GPR) Scans of one-hundred and fifty-six (156) piers by scanning four (4) grids at each pier location. A grid will consist of a three (3) foot by two (2) foot rectangle made up of thirty-five (35) gridlines spaced at six (6) inches on center. Total linear footage of scanning will be eighteen thousand and ninety-six (18,096) feet. The report will include detailed rebar locations of the piers. The proposal cost for this service was \$56,000.00.

At the Facilities/Environment Committee Meeting of February 05, 2020 this proposal and engineering service was presented and discussed. At this time the decision was made for Administration to proceed with Hinojosa Structural Engineering and MEG Engineers to conduct only seventy-eight (78) GPR Scans on the stadium. These scans would be divided between the home and visitors side piers at a proposal cost of \$34,988.00.

At the Regular Board of Trustees meeting held on April 08, 2020 the Board approved the following, Preliminary reports from both engineering firms indicate that a complete GPR Scan of all piers would be advisable to have a complete pier assessment on the stadium. Thus, Administration recommends Consideration and Approval of Additional Ground Penetrating Radar (GPR) Scans for Piers at the Tom Landry Stadium Bleacher Project. The estimated proposal cost would be the difference from the original proposal to what has been approved for the first phase. Estimated proposal \$21,012.00.

At the Regular Board of Trustees meeting held on September 09, 2020, as an informational Board Item, a presentation was given by Rick Hinojosa Structural Engineering, Mr. Albert Trevino, on the Tom Landry Stadium Renovation Project status. Mr. Trevino reported on the findings for the GPR scans conducted and has stated, "the scans in the report indicate that the majority of the piers do not have pier reinforcement per the shop/erection drawings provided by Sturdy Steel who provided the bleachers".

At the meeting of September 09, 2020, Hinojosa Structural Engineering was to provide a final and complete comprehensive report on the findings and recommendations for correction on all items indicated on the assessment. Findings and recommendations were to include and not limited to the disciplines of Structural, Mechanical, Electrical, Plumbing (MEP) and Civil. At this meeting Hinojosa Structural Engineering was directed to provide this comprehensive report and not only the GPR scans report.

Since this initial directive, Hinojosa Structural Engineering has been contacted both on October and December 2020 for the final report and we continue to have no response. Administration will continue to utilize all avenues to request the final report so that we may move forward with repairs required.

On January 14, 2021, Rick Hinojosa Structural Engineering was sent both an email correspondence and a certified letter requesting his personal appearance at the Wednesday, January 20, 2021 Board of Trustees Work Shop to present the final project findings. At 4:01 p.m. on that day Mr. Hinojosa contacted us that he had a family emergency and would try to attend. With this correspondence he attached "Mission CISD Tom Landry Stadium Ground Penetration Radar (GPR) Scanning Findings Letter". This letter referenced the GPR scanning done at the stadium.

In discussion at the Work Shop of January 14, 2021, the Board instructed our legal counsel to draft a letter to request Mr. Hinojosa's presence and to once again present his findings at the Board Work Shop of Wednesday, February 03, 2021. Legal counsel sent a certified letter and emailed the letter to Mr. Hinojosa's attention on Tuesday, January 26, 2021. My office then proceeded to re-send this letter to Mr. Hinojosa the following day. A "read receipt" message was received from his office on Friday, January 29, 2021 at approximately 12:10 p.m. acknowledging receipt of our request to be present.

At this Work Shop of Wednesday, February 03, 2021, the Board will hear the presentation and may have a question and answer session with Mr. Hinojosa on the findings and recommendations. At this time the Work Shop may have a Discussion and Possible Action to Procure Engineering Services for Analysis and Remediation for the Tom Landry Stadium Project and to Grant Administration Authorization to Procure Services. The presentation was not held at the Work Shop and was presented at a Special Board of Trustees Meeting after.

At the Special Board of Trustees meeting of Wednesday, February 03, 2021, Mr. Rick Hinojosa presented his "Mission CISD Tom Landry Structural Comprehensive Assessment Report". After discussion with the Board of Trustees and Administration, Mr. Hinojosa was directed to once again present at the Regular Board of Trustees meeting of Wednesday, February 10, 2021. This presentation is to mainly address all the viable options on how to correct the issue of the piers found to be not safe and not constructed as per code as noted in the report and reported by Mr. Hinojosa at the meeting. He is to also present a scope of work and a phasing plan of repairs beginning with the most safety critical items. What will also need to be addressed is if any other areas will be damaged while repairing the piers, such as the flatwork. Each option(s) will need to satisfy all building and structural codes along with satisfying all safety compliance codes. At this meeting Mr. Hinojosa was advised that time was critical for the usage of the stadium since graduation ceremonies have already been scheduled. Mr. Hinojosa stated that plans and specifications should be finalized soon and we may be able to advertise for competitive sealed proposals (CSP's) within the next couple of weeks and possibly have a contractor begin repairs as quickly as the procurement process allows, that is the goal.

The procurement process will be Competitive Sealed Proposals (CSP's) of which the Board adopted as the method of delivery. The Board approved the Hidalgo County Prevailing Wage Rate of which is an exhibit and was attached. The Board also adopted the selection criteria of which proposals are evaluated and ranked. Administration also recommended that the Board authorized the Superintendent to rank the proposals and to negotiate an agreement with the highest ranked contractor.

On February 10, 2021, the Board approved Consideration and Possible Action Regarding Permanent and Emergency Repairs for the Tom Landry Stadium to Include the Wage Rate, Selection Criteria, and Authorization to Dr. Perez as mentioned under the Administrative considerations.

Advertisements in the local newspapers for Competitive Sealed Proposals (CSP's) were posted on March 24, 2021 and March 31, 2021. Proposals were to be opened April 08, 2021 and firms would be able to view remotely. The virtual pre-proposal meeting was Thursday, April 01, 2021 at 2:00 p.m. to allow all prospective contractors the opportunity to ask questions concerning the project plans and specifications.

CSP's were to be submitted on April 8, 2021, and were to be reviewed and ranked by the Administration Committee. This Administrative review was to be presented at the Regular Board of Trustees Meeting of Wednesday, April 14, 2021.

On Wednesday, April 06, 2021 Hinojosa Structural Engineering submitted a recommendation to extend the bid⁴⁹date by two weeks to allow contractors and sub-

contractors more time to bid on the project. He also stated that a second pre-bid conference be held followed by a walk-through of the stadium facility. This recommendation was due also to no contractors attending the initial pre-bid conference. This recommendation was presented at the Board of Trustees Work Shop on Wednesday, April 08, 2021.

A second pre-proposal meeting was held on Thursday, April 15, 2021. With the two-week extension proposals were due and publicly opened on Thursday, April 22, 2021 at 2:00 p.m. at the Central Office Board Room. Proposals were reviewed, evaluated and ranked on Monday, April 26, 2021 at 2:00 p.m. by Ms. Rumalda Ruiz, Ms. Dora Garcia, Ms. Lorena Garcia, Mr. Joel Garcia and Mr. Ricardo Rivera with Ms. Daisy Cuevas assisting.

Due to the timeline to begin permanent repairs Administration requested a Special Board of Trustees meeting on Tuesday, April 27, 2021 at 12:00 p.m. at the Central Office Board Room. At this meeting Administration presented and the Board approved Consideration and Approval to Accept Administrations Rankings and Enter Into Negotiations in the Order of Ranking for the Tom Landry Stadium Repairs Project.

G & G Construction

Base Bid: \$1,024,850.00 with 210 construction days

Alternate Bird Screen: \$127,000.00 with an additional 45 construction days

TOTAL: \$1,151,850.00 with 255 days from notice to proceed (approx. 8.5 months)

Terra Fuerte Const.

Base Bid: \$1,141,000.00 with 180 construction days

Alternate Bird Screen: \$30,000.00 with an additional 30 construction days

TOTAL: \$1,171,000.00 with 210 days from notice to proceed (approx. 7 months)

Project negotiations were scheduled for Wednesday, May 05, 2021 at 10:00 a.m. as per G & G Constructions earliest available meeting date and time. Administration presented Consideration and Approval to Accept the Best and Final Offer (BAFO) and to Enter Into Contract for the Tom Landry Stadium Repairs Project and requested for a Special Board of Trustees meeting following the Board Work Shop to consider action on this item.

The Board of Trustees has the option to accept this BAFO, the initial base proposal, to decline the offer and direct Administration to enter into negotiations with the next contractor or to reject all offers and re-advertise for the project using the same specifications and design or direct the engineer to re-design the project.

At the Special Board meeting held on May 5, 2021, the Board approved G & G Contractors Best and final offer Base Bid: \$1,024,850.00 with 210 construction days. Notice to proceed was effective July 28, 2021, with substantial completion will be February 23, 2022.

At the Regular Board meeting held on November 10, 2021, the Board approved the following items:

Consideration and Approval of Allowance Expenditure Authorization (AEA) #01 for Structural Repairs on Various Piers for the Tom Landry Stadium Repairs.

Contingency Allowance:	\$20,000.00
AEA #1 Various Piers:	<u>\$ 8,241.88</u>
Balance:	\$11,758.12

Consideration and Approval of Change Order #1 for Forty-four (44) Delay Days due to the structural repairs on various piers for the Tom Landry Stadium Repairs. If approved the new substantial completion will be April 08, 2022.

On Friday, December 10, 2021 a letter was sent by MCISD to Mr. Rick Hinojosa, Hinojosa Structural Engineering and to Mr. Rene Garza, RG Enterprises LLC. referencing the Tom Landry Stadium Repair Project.

At the request of Mr. Garza, a project meeting was held on Wednesday morning, December 15, 2021 to discuss items referenced in the letter. Present at the meeting were staff members of R. Hinojosa Structural Engineering, Raba Kistner, Geo-tech Testing, G&G Const. and MCISD Staff.

At the Regular Board of Trustees meeting held on December 15, 2021, Mr. Albert Trevino. Hinojosa Structural Engineering and Mr. Rene Garza, RG Enterprises LLC presented an update on the project. During the presentation at least five (5) possible change orders which consist of additional costs and time were mentioned as forthcoming.

The Board expressed concern that the project needed to move forward and that requests for special meetings would be acceptable in order to expedite change orders needed as to not delay the project further.

A Special Board of Trustees Meeting has been requested for Wednesday, January 05, 2022 for Consideration and Approval of Change Order(s) for the Tom Landry Stadium Repairs Project.

At the Regular Board of Trustees meeting of December 15, 2021, both firms were instructed to work on change proposals to be submitted at the special called meeting of Wednesday, January 5, 2022. During the presentation by both Mr. Albert Trevino – Hinojosa Structural Engineering and Mr. Rene Garza – RG Enterprises, LLC they presented seven (7) possible construction proposal requests (CPR's). They were directed to present to the Administration and Board of Trustees detailed explanations for each CPR on why these were required, if by Code or other reasons. They were also directed to ensure that these CPR costs were the only option(s). It was also directed that they needed to specify if any of the CPR's would either delete or offset any of the work already included in their original scope of work and that the adjustment of all time and materials associated needed to be reflected as a "credit" to the district. As per Mr. Trevino, he would only inform the Administration and the Board of receipt of these CPR's and at this time would not formally present them for consideration since he had not yet reviewed them with RG Enterprises, LLC and did have some questions for them. Both firms were made aware that legally the project could not exceed 25% of the total cost of the project in change orders. Administration and the Board once again reiterated the need to resume work at the stadium and were very receptive to having meetings to review and possibly approve items to have the project progress. The Board asked which CPR's were critical at this time so that the project would continue and items #3, #5 and #6 that

were presented that evening were noted. Both firms were directed to work on submitting these CPR's using the required AIA Document G701 - 2017 which specifically is designed to submit change orders to the project and present them at a Special Board of Trustees meeting on Wednesday, January 12, 2022.

At the Special Board of Trustees meeting held on Wednesday, January 12, 2022, R. Hinojosa Structural Engineering and RG Enterprises, LLC presented possible change orders #2, #3 and #4. Change order #4 was the combination of Change Proposal Requests (CPR's) #5 and #6 that were presented at the previous meeting of January 05, 2022. Along with cost information were additional days requested. In consultation with Mr. David Hansen - Legal Counsel it was asked that the change orders be reviewed once again and that the costs and days all be incorporated into one single change order document. The change order was to be sent to our legal office to be incorporated into our required change order document. Both firms were asked to create a work schedule separating time from the home side versus the visitor side. A presentation is scheduled to be made once again at the Regular Board of Trustees meeting on Wednesday, January 19, 2022.

At the Regular Board of Trustees meeting held on Wednesday, January 19, 2022, R. Hinojosa Structural Engineering and RG Enterprises, LLC once again presented possible costs and change orders with a substantial completion date of early November 2022. This item was taken into Executive Session for consultation with our legal counsel.

After consultation and review, the decision and directive to both R. Hinojosa and RG Enterprises was to split the project between the home side repairs and the visitor repairs. Each side was to be a separate project with RG Enterprises submitting a change order for credit to work being separated from the visitor side and an updated schedule of values for completing the home side as this was the priority. A brief meeting was held after the Board of Trustees meeting with the design team, the general contractor, and MCISD staff to ensure that they understood the directive issued, of which they acknowledged that they understood. The directive was to have the change order with new updated costs, credits and timeline by the regularly scheduled Board Workshop on Wednesday, February 02, 2022.

Correspondences continued this past week with uncertainty from RG Enterprises about what was required and expecting a written authorization from Dr. Perez, MCISD Superintendent concerning what was directed at the previous Board meeting. A Zoom meeting was held on Thursday, January 27, 2022 with R. Hinojosa Staff, Mr. Manuel Leal, G & G Construction Superintendent, Mr. Adrian Hernandez, Mr. Adan Rivera, Ms. Lorena Garcia, and Mr. Rick Rivera to clarify the directive and expectations and the urgency for submitting the required change orders. It was presented that there would be no written authorization from Dr. Perez and that the directive issued at the Board meeting would suffice. It was also discussed that the general contractor was directed in an email by R. Hinojosa and Mr. Adrian Hernandez of what was required, Mr. Leal acknowledged the direction. A Zoom meeting was once again scheduled for Friday, January 28, 2022 to review the status of the change order. Once again both the general contractor and design team were directed to submit all change orders in a timely manner and not at the last minute when Administration does not have time to review before the presentations to Dr.

Perez and the Board of Trustees. It was also noted that for all meetings we needed to have either Mr. Adrian Hernandez or Mr. Adan Rivera present.

At the Special Board of Trustees meeting held on February 02, 2022, the Board, approved to separate the Tom Landry Stadium Repairs into two separate projects, home side and visitor's side. The home side will be a priority with the current contract. Currently RG Enterprises, LLC, general contractor, is to submit a new schedule of values, credits and a new timeline for them to continue and complete the home side as scheduled.

Questions were asked of why the credit was minimal compared to the overall project cost. As per both firms they had a difference of opinions on their calculations. Due to these differences and R. Hinojosa Structural Engineering not supporting the change orders in the best interest of the District the Board and Administration directed both firms to once again meet and come to a mutually agreeable change order to present at the Regular Board of Trustees meeting on Wednesday, February 09, 2022.

The Board approved at the same meeting, the visitor's side as a new project, procurement and proposed budget for supplemental repairs (Visitors Side) for the Tom Landry Stadium Project.

Administration does anticipate work by outside contracting firms for the Supplemental Repairs (Visitors Side) for the Tom Landry Stadium Project, thus, before soliciting bids or proposals for this project, Texas Education Code 44.031(a) requires the board of a school district, considering a construction project to take the following action.

1. The board must consider the method of delivery that provides the best value for this project. Administration recommends competitive sealed proposals as the method of delivery due to the nature of the project.

2. Selection criteria for the project must also be considered. Attached is a copy of the recommended selection criteria used for previous District large scale projects.

3. The Board must designate the selection committee to evaluate and rank the proposals.

(This was reviewed and approved by the Purchasing Department)

At the Regular Board of Trustees meeting held on Wednesday, February 09, 2022, Administration presented the items that were discussed at the Special Board of Trustees meeting held on Wednesday, February 02, 2022, copies of proposed change orders were distributed. Change orders consisted of credits for eliminating the south side visitor part of the project, owner contingency allowance changes, pricing per pier work on the home side, substantial completion date of August 08, 2020 and a new construction cost for the north side home part. This information was presented by Mr. Albert Trevino – R. Hinojosa Structural Engineering and Mr. Manuel Leal – RG Enterprises, LLC (Job Superintendent for General Contractor). Again, the importance of having this project begin construction and completed was highly stressed by Dr. Perez, MCISD Superintendent and the Board of Trustees. Change Order #2 for⁵³ deletion of work and credit was presented and

approved for the amount of \$166,235.09. Change Order #3 for additional repairs, re-routing of existing storm drain, repairs on piers and amounts added to the Owners contingency and other was presented and approved.

Note: Construction documents and schematic designs were not available for presentation at the Board Workshop on Wednesday, March 02, 2022 and are being presented at the Board Meeting. As per Mr. Albert Trevino, the construction timeline is scheduled to be approximately four months. If approved advertisement for proposals will follow.

Schematic Design:

Rough sketches that develop a feasible conceptual design of the project.

Construction Documents:

Communicating the design intent through further refinement of the written and graphic representation of all building materials, components and equipment that can be quantified and useful to contractors.

At the Regular Board of Trustees Meeting held on March 09, 2022 the Board approved Construction Documents for the Supplemental Repairs (Visitors Side) for the Tom Landry Stadium Repairs Project – R. Hinojosa Engineering, Inc.

Advertisements in the local newspapers were posted on March 16, 2022 and March 23, 2022. The process is for the submittals to be reviewed by the Purchasing Department Staff and the Administration Ranking Team to assure that firms meet the criteria based on demonstrated expertise, competence and qualifications. Pre-proposal was scheduled for Thursday, March 24, 2022 and Bid Opening for March 31, 2022. After the review Administration will then recommend those firms to be reviewed and ranked in order of selection. The recommendations were presented for approval at the Wednesday, April 06, 2022 Special Board of Trustees Meeting and Administration will then enter into negotiations in the order of selection.

<u>Company</u>	<u>Total Base Bid</u>	<u>Days of Completion</u>	<u>Points</u>
Terra Fuerte	\$489,000.00	150	88.0

ADMINISTRATIVE CONSIDERATIONS

Project negotiations are currently being scheduled prior to the Regular Board of Trustees meeting to be held on April 13, 2022 with Terra Fuerte. It is Administrations intent to bring forward a Best and Final Offer (BAFO) for Board consideration and approval. If approved, Administration will work with our legal counsel to write and execute the construction contract so that the contractor can begin as soon as possible.

FUNDING SOURCE

General Funds and Possible other funding sources to be determined by the Finance Dept. (TBD)

RECOMMENDATION

Administration presents Consideration and Approval to Accept Best and Final Offer (BAFO) for Supplemental Repairs (Visitors Side) for the Tom Landry Stadium Repairs Project – Ricardo Hinojosa Engineering, Inc.

EXHIBIT

Best and Final Offer (BAFO) (Pending negotiations)
Bid Tabulation

CONTACT PERSONS

Ricardo Rivera, Assistant Superintendent for Operations
Adrian Hernandez, Coordinator for Project & Energy Management

Mission Consolidated Independent School District
Tom Landry Stadium Civil and Structural Repairs Visitor's Side CSP # 500-22-4
Bid Ranking - April 1, 2022

Contractors			Terra Fuerte
Proposal Submission			
	Complete Proposal		x
	Bid Bond - 00410		x
CRITERIA		Max Points	
Monetary Value - 35 points			
1	Base Proposal and/or Alternate(s) selected by Owner. Based on proposals submitted, including any alternates and/or pricing differential.	35	35.0
	Total Base Bid		\$489,000
	Days of Completion		150
Qualifications and Reputation - 20 points			
2	Contractor's length of time in the construction business.	7	2
3	Contractor's past relationship with other clients on similar projects. Provide three (3) letters of reference from Owners identified in the lists of projects completed within the past five (5) years of similar scope and size.	5	5
4	Address history and procedure for assuring timely payment to sub-contractors and suppliers. Provide three (3) letters of reference from major suppliers and sub-contractors which specifically address the proposer's history of paying sub-contractors and material providers on time.	2	1
5	Prior experience with architectural and/or engineering firms. Provide a letter of reference from an Architectural or Engineering firm addressing the contractor's history of providing detailed documentation and a fair assessment of change order pricing.	2	2
6	List all claims, judgments, arbitration proceedings or suits pending or outstanding against your company for its officers . If any, please summarize the nature of these claims.	2	2
7	List all claims, judgments, arbitration proceedings or suits that your company or its officers has filed against a school district within the past ten (10) years?. If so, please summarize the nature of these claims.	2	2
Experience with Similar Projects - 20 points			
8	Contractor's experience with school district projects of similar size, type and complexity. List school district projects completed within the past five (5) years of similar scope and size.	15	15
9	Contractor's experience with projects of similar size, type and complexity. List all other projects completed within the past five (5) years of similar scope and size other than the ones listed above .	5	5
Key Personnel and Workforce - 8 points			
10	Qualifications and availability of contractor's personnel. Provide the names and a brief summary of experience or resume of key supervisory personnel to be assigned to the project. Provide history of maintaining assigned personnel for the duration of project.	5	5
11	Contractor's proposed sub-contractors. Provide a list of the sub-contractors that will be assigned to this project.	3	3
Past Performance with District - Quality of Work and Adherence to Contract Terms - 5 points			
12	List projects completed or in progress for Mission CISD.	5	0
HUB Certification - 0.5 points			
13	Provide documentation to assist compliance with laws and rules relating to Historically Underutilized Businesses.	0.5	0.5
Proposed Schedule for Construction - 5 points			
14	Contractor's ability to adhere to construction schedule. Provide proposed schedule of construction from commencement through substantial and final completion.	5	5
Financial Strength of Company - 2 points			
15	Provide a letter from your bonding company addressing the points listed in the item 15 of the Contractor's Information Statement Form.	1	1
16	Provide a bank letter of reference with regards to the company's financial strength.	0.5	0.5
17	Provide a statement attesting if the company or company's principals under other company names ever filed for bankruptcy.	0.5	0
Thoroughness of Bid Submission and Quality of Presentation - 4.5 points			
18	Provide the Contractor's Checklist, including the documents required and the copies in the order requested. Contractor must submit everything required in project specifications including Contractor's Information Statement.	4.5	4
Total Points		100	88.0
Rank (1 is Highest)			1

Committee Members:

Ricardo Rivera, Assistant Superintendent for Operations
Adrian Hernandez, Coordinator for Projects and Energy Management
Adan Rivera, Assistant Coordinator for Maintenance

SUBJECT: Consideration and Approval to Accept Best and Final Offer (BAFO) for Synthetic Turf for the Baseball & Softball Fields at Mission High School and Veterans Memorial High School – Javier Hinojosa Engineering

PRESENTER: Ricardo Rivera, Assistant Superintendent for Operations

BACKGROUND INFORMATION

Mission CISD is proposing of installation of synthetic turf for the baseball and softball fields at both high schools. The installation of synthetic turf will provide a continuous level playing field that will provide safety by possibly eliminating “bad’ hops and limiting possible player injuries. The turf will also be a cost savings due to weekly and annual maintenance costs of watering, fertilizing, herbicides, painting, mowing, top dressing, etc. not having to be done.

Due to laws and requirements that regulate such equipment and the cost, this project is being considered a construction project and as such the Texas Education Code 44.031 (a) requires the board of a school district considering a construction project to comply with bidding requirements.

Administration will use competitive sealed proposals (CSP’s) as the procurement method as approved by the Board of Trustees in the February 2021 Board of Trustees meeting. This method was approved as the primary default method for projects.

As per information concerning synthetic turf areas, the area covering a baseball field is of equal or slightly more square feet area than a football field. Administration is using an estimated cost from previous turf quotes and most recent information gathered.

If MCISD is to proceed with this project, The Board of Trustees must take the following action in accordance with Education Code 44.035.

Select or designate an engineer or architect to prepare construction documents for the project. The engineer or architect selected or designated will have full responsibility for complying with the Texas Engineering Practice Act (Article 3271a, Vernon’s Texas Civil Statutes) or Chapter 478, Acts of the 45th Legislature, Regular Session, 1937 (Article 249a, Vernon’s Texas Civil Statutes), as applicable.

The selected architect/engineer along with preparing construction documents will be required to provide MCISD with an estimated project budget.

If the engineer or architect is not a full-time employee of the District, the Board must select the engineer or architect on the basis of demonstrated competence and qualifications as provided by Section 2254.004, Government Code.

Due to the estimated cost being over the \$500,000.00 threshold for on-call services Administration requests Discussion and Possible Action on the Selection for Professional Services for Synthetic Turf for the Baseball and Softball Fields at VMHS and MHS.

The Board may direct Administration to advertise for Request for Qualifications (RFQ’s) or select an architect/engineer used in the past or present based on demonstrated competence and qualifications. Civil engineering professional services were used for

the installation of synthetic turf in 2014. Administration recommends civil engineering services.

At the Regular Board meeting held on August 11, 2021, the Board approved the project, proposed budget and utilizing the on-call professional services for the Synthetic Turf for the Baseball & Softball Fields at Mission High School and Veterans Memorial High School - Javier Hinojosa Engineering.

At the Board of Trustees Workshop on February 02, 2022 and as per discussion Mr. Hinojosa and Staff will continue working on the sideline lettering placement to be more visible to the persons in the stands and to ensure that this lettering along with the district logo recommended behind home plate does not violate any playing field regulations. It was also recommended to improve the visibility of the lettering throughout by possibly enhancing the colors or outlining the lettering. Mr. Hinojosa and staff will continue meeting to have everyone's input and also ensuring that both campus fields are equitable and similarly designed as much as possible.

At the Regular Board meeting held on February 09, 2022, the Board approved Schematic Designs for the Synthetic Turf for the Baseball & Softball Fields at the Mission High School and Veterans Memorial High School.

Schematic Design:

Rough sketches that develop a feasible conceptual design of the project.

Construction Documents:

Communicating the design intent through further refinement of the written and graphic representation of all building materials, components and equipment that can be quantified and useful to contractors.

At the Board Workshop on Wednesday, March 02, 2022, Mr. Javier Hinojosa, Hinojosa Civil Engineering presented the four original designs and the four alternate designs. All recommendations from Administration, Coaches, Campus Administration and those from the Board of Trustees have been incorporated. At the Workshop all options were discussed along with the approved established construction budget. Administration presented that we would look into all alternates recommended but that due to the decrease in student enrollment and funding alternates may need to be revisited at another time when funding was available.

At the Regular Board of Trustees meeting held on March 09, 2022, the Board approved to Accept Final Design for the Synthetic Turf for the Baseball & Softball Fields at Mission High School and Veterans Memorial High School – Javier Hinojosa Engineering. Designs have been reviewed and approved by staff.

Advertisements in the local newspapers were posted on March 16, 2022 and March 23, 2022. The process is for the submittals to be reviewed by the Purchasing Department Staff and the Administration Ranking Team to assure that firms meet the criteria based on demonstrated expertise, competence and qualifications. Pre-proposal was scheduled for Thursday, March 24, 2022 and Bid Opening for March 31, 2022. After the review Administration will then recommend those firms to be reviewed and ranked in order of selection. The recommendations were presented for approval

at the Wednesday, April 06, 2022 Special Board of Trustees Meeting and Administration will then enter into negotiations in the order of selection.

<u>Company</u>	<u>Total Base Bid</u>	<u>Total with Alternates Base Bid</u>	<u>Days of Completion</u>	<u>Points</u>
Hellas	\$3,881,300.00	\$4,026,570.00	120	97.3/97.5
Field Turf	\$3,576,395.00	\$3,737,120.00	185/190	88.5/88.5

ADMINISTRATIVE CONSIDERATIONS

Project negotiations are currently being scheduled prior to the Regular Board of Trustees meeting to be held on April 13, 2022 with Hellas Construction. It is Administrations intent to bring forward a Best and Final Offer (BAFO) for Board consideration and approval. If approved, Administration will work with our legal counsel to write and execute the construction contract so that the contractor can begin as soon as possible. If the BAFO is not approved it is the process to then cease negotiations with the top ranked firm and proceed into negotiations with the second ranked firm.

FUNDING SOURCE

Local Fund

Est. Project Budget:	\$3,200,000.00
Project Contingency 20%:	\$ 640,000.00
Est. Professional Services 12%:	<u>\$ 384,000.00</u>
Est. Total Project Cost:	\$4,224,000.00

RECOMMENDATION

Administration is presenting Consideration and Approval to Accept Best and Final Offer (BAFO) for Synthetic Turf for the Baseball & Softball Fields at Mission High School and Veterans Memorial High School – Javier Hinojosa Engineering

EXHIBIT:

Best and Final Offer (BAFO) (Pending negotiations)
Bid Tabulation

CONTACT PERSONS

Ricardo Rivera, Assistant Superintendent for Operations
Adrian Hernandez, Coordinator for Project & Energy Management

Mission Consolidated Independent School District
 Synthetic Turf for Baseball and Softball Fields at MHS and VMHS CSP # 500-22-5
 Bid Ranking - April 1, 2022

Contractors			Field Turf	Field Turf Alternate	Hellas	Hellas Alternate
Proposal Submission						
	Complete Proposal		x	x	x	x
	Bid Bond - 00410		x	x	x	x
CRITERIA		Max Points				
Monetary Value - 35 points						
1	Base Proposal and/or Alternate(s) selected by Owner. Based on proposals submitted, including any alternates and/or pricing differential.	35	35.0	35.0	32.3	32.5
	Total Base Bid		\$3,576,395	\$3,737,120	\$3,881,300	\$ 4,026,570
	Days of Completion		185	190	120	120
Qualifications and Reputation - 20 points						
2	Contractor's length of time in the construction business.	7	7	7	7	7
3	Contractor's past relationship with other clients on similar projects. Provide three (3) letters of reference from Owners identified in the lists of projects completed within the past five (5) years of similar scope and size.	5	5	5	5	5
4	Address history and procedure for assuring timely payment to sub-contractors and suppliers. Provide three (3) letters of reference from major suppliers and sub-contractors which specifically address the proposer's history of paying sub-contractors and material providers on time.	2	2	2	2	2
5	Prior experience with architectural and/or engineering firms. Provide a letter of reference from an Architectural or Engineering firm addressing the contractor's history of providing detailed documentation and a fair assessment of change order pricing.	2	2	2	2	2
6	List all claims, judgments, arbitration proceedings or suits pending or outstanding <u>against your company for its officers</u> . If any, please summarize the nature of these claims.	2	0	0	2	2
7	List all claims, judgments, arbitration proceedings or suits that your company or its officers has filed <u>against a school district</u> within the past ten (10) years?. If so, please summarize the nature of these claims.	2	0	0	2	2
Experience with Similar Projects - 20 points						
8	Contractor's experience with <u>school district</u> projects of similar size, type and complexity. List school district projects completed within the past five (5) years of similar scope and size.	15	15	15	15	15
9	Contractor's experience with projects of similar size, type and complexity. List all other projects completed within the past five (5) years of similar scope and size <u>other than the ones listed above</u> .	5	5	5	5	5
Key Personnel and Workforce - 8 points						
10	Qualifications and availability of contractor's personnel. Provide the names and a brief summary of experience or resume of key supervisory personnel to be assigned to the project. Provide history of maintaining assigned personnel for the duration of project.	5	5	5	5	5
11	Contractor's proposed sub-contractors. Provide a list of the sub-contractors that will be assigned to this project.	3	3	3	3	3
Past Performance with District - Quality of Work and Adherence to Contract Terms - 5 points						
12	List projects completed or in progress for Mission CISD.	5	0	0	5	5
HUB Certification - 0.5 points						
13	Provide documentation to assist compliance with laws and rules relating to Historically Underutilized Businesses.	0.5	0	0	0.5	0.5
Proposed Schedule for Construction - 5 points						
14	Contractor's ability to adhere to construction schedule. Provide proposed schedule of construction from commencement through substantial and final completion.	5	5	5	5	5
Financial Strength of Company - 2 points						
15	Provide a letter from your bonding company addressing the points listed in the item 15 of the Contractor's Information Statement Form.	1	1	1	1	1
16	Provide a bank letter of reference with regards to the company's financial strength.	0.5	0	0	0.5	0.5
17	Provide a statement attesting if the company or company's principals under other company names ever filed for bankruptcy.	0.5	0	0	0.5	0.5
Thoroughness of Bid Submission and Quality of Presentation - 4.5 points						
18	Provide the Contractor's Checklist, including the documents required and the copies in the order requested. Contractor must submit everything required in project specifications including Contractor's Information Statement.	4.5	3.5	3.5	4.5	4.5
Total Points		100	88.5	88.5	97.3	97.5
Rank (1 is Highest)			2	2	1	1

Committee Members:

Ricardo Rivera, Assistant Superintendent for Operations
 Adrian Hernandez, Coordinator for Projects and Energy Management
 Adan Rivera, Assistant Coordinator for Maintenance
 Dora Garcia, Purchasing Coordinator
 Daisy Cuevas, Purchasing Specialist

SUBJECT: Consideration and Approval to Accept Best and Final Offer (BAFO) for Demolition of the Technology/Radio Tower Project – Chanin Engineering

PRESENTER: Ricardo Rivera, Assistant Superintendent for Operations

BACKGROUND INFORMATION

The existing radio tower has been at this same location for many years, on a recent evaluation by an outside firm it was noted that the tower has endured weather damages over time. Concerns expressed is that any future storm or hurricane could damage the exiting tower, disrupting the radio communication for the bus fleet and other district vehicles. The firm also noted that the tower is deemed to be unsafe for climbing to do repairs.

In December of 2016 Chanin Structural Engineering was contracted to conduct a structural assessment at the technology/radio tower located behind CNP. Findings showed tower rust and deteriorations and a report with photographs was provided. Cost of the assessment was \$7,500.00. The tower was then leased to an outside entity and as per contract they were to maintain the structure. This entity no longer exists; thus, MCISD is responsible and liable for any issues pertaining to the tower. Reception issues have arisen due to the tower swaying and will require maintenance of possible tightening of the guide wires. Due to the past report we recommend that another assessment be conducted to re-assess if further deterioration has occurred. A structural engineer will be required for this project.

Administration will use competitive sealed proposals (CSP's) as the procurement method as approved by the Board of Trustees in the February 2021 Board of Trustees meeting. This method was approved as the primary default method for projects. However, at the November 10, 2021 Board of Trustees meeting, the Board approved Job Order Contracting (JOC) and this method may be used for this smaller project.

Administration used the on-call professional services agreement for project administration and assigned this project to Chanin Structural Engineering. It will be the responsibility of the design/engineer professional to provide an estimated project budget.

Upon meeting with Mr. Miguel Chanin he advised us that conducting another structural assessment would be a mute service since nothing had changed since his original assessment of 2016 and possibly the structure only deteriorated more. He advised us that his original report recommendations were still valid.

At the Regular Board of Trustees Meeting held on August 11, 2021, the Board approved of Utilizing the On-call Professional Services for the Removal of the Technology /Radio Tower Structural Project - Chanin Structural Engineering.

At the Regular Board of Trustees Meeting held on December 15, 2021, the Board approved Schematic Design for the Demolition of the Technology/Radio Tower Project – Chanin Engineering.

At the Regular Board of Trustees Meeting held on February 09, 2022, the Board approved Final Design for the Demolition of the Technology/Radio Tower Project. Administration will move forward to seek proposals for the demolition or utilize our approved on-call listing.

Advertisements in the local newspapers were posted on February 23, 2022 and March 02, 2022. The process is for the submittals to be reviewed by the Purchasing Department Staff and the Administration Ranking Team to assure that firms meet the criteria based on demonstrated expertise, competence and qualifications. Pre-ranking was done on Thursday, March 17, 2022. After the review Administration will then recommend those firms to be reviewed and ranked in order of selection. The recommendations will then be presented at the April 06, 2022 Special Board of Trustees meeting to authorize Administration to then enter into negotiations in the order of selection. If successful Administration would present consideration and approval to enter into contract at the Regular Board of Trustees meeting on Wednesday, April 13, 2022.

<u>Company</u>	<u>Base Proposal</u>	<u>Days</u>	<u>Pts.</u>
Building Abatement Demolition	\$86,900.00	14 Days	77.5
Econ	\$220,000.00	30 Days	63.5
Hunter Demolition & Wrecking	\$122,000.00	05 days	59
Western Towers	\$83,176.00	N/A	0

ADMINISTRATIVE CONSIDERATIONS

Project negotiations are currently being scheduled prior to the Regular Board of Trustees meeting to be held on April 13, 2022 with Building Abatement Demolition. It is Administrations intent to bring forward a Best and Final Offer (BAFO) for Board consideration and approval. If approved, Administration will work with our legal counsel to write and execute the contract so that the contractor can begin as soon as possible. If the BAFO is not approved it is the process to then cease negotiations with the top ranked firm and proceed into negotiations with the second ranked firm.

FUNDING SOURCE

Local Fund

RECOMMENDATION

Administration presents Consideration and Approval to Accept Best and Final Offer (BAFO) for Demolition of the Technology/Radio Tower Project – Chanin Engineering

EXHIBIT:

Best and Final Offer (BAFO) (Pending negotiations)
 Bid Tabulation

CONTACT PERSONS

Ricardo Rivera, Assistant Superintendent for Operations
 Adrian Hernandez, Coordinator for Project & Energy Management

Mission Consolidated Independent School District
Technology Radio Tower Demolition CSP # 500-22-3
Bid Ranking

Contractors		Building Abatement Demolition	Econ	Hunter Demolition & Wrecking	Western Towers*	
Proposal Submission						
	Complete Proposal	x	x	x		
	Bid Bond - 00410	x	x	x		
CRITERIA		Max Points				
Monetary Value - 35 points						
1	Base Proposal and/or Alternate(s) selected by Owner. Based on proposals submitted, including any alternates and/or pricing differential.	35	35	14	25	N/A
	Total Base Bid	\$ 86,900	\$ 220,000	\$ 122,000	\$ 83,176	
	Days of Completion	14	30	5	N/A	
Qualifications and Reputation - 20 points						
2	Contractor's length of time in the construction business.	7	7	7	7	
3	Contractor's past relationship with other clients on similar projects. Provide three (3) letters of reference from Owners identified in the lists of projects completed within the past five (5) years of similar scope and size.	5	5	5	2	
4	Address history and procedure for assuring timely payment to sub-contractors and suppliers. Provide three (3) letters of reference from major suppliers and sub-contractors which specifically address the proposer's history of paying sub-contractors and material providers on time.	2	2	2	0	
5	Prior experience with architectural and/or engineering firms. Provide a letter of reference from an Architectural or Engineering firm addressing the contractor's history of providing detailed documentation and a fair assessment of change order pricing.	2	0	1	0	
6	List all claims, judgments, arbitration proceedings or suits pending or outstanding against your company for its officers . If any, please summarize the nature of these claims.	2	2	2	2	
7	List all claims, judgments, arbitration proceedings or suits that your company or its officers has filed against a school district within the past ten (10) years?. If so, please summarize the nature of these claims.	2	2	2	2	
Experience with Similar Projects - 15 points						
8	Contractor's experience with school district projects of similar size, type and complexity. List school district projects completed within the past five (5) years of similar scope and size.	5	5	5	1	
9	Contractor's experience with projects of similar size, type and complexity. List all other projects completed within the past five (5) years of similar scope and size specific to the demolition of technology radio towers .	10	0	0	5	
Key Personnel and Workforce - 8 points						
10	Qualifications and availability of contractor's personnel. Provide the names and a brief summary of experience or resume of key supervisory personnel to be assigned to the project. Provide history of maintaining assigned personnel for the duration of project.	5	5	5	5	
11	Contractor's proposed sub-contractors. Provide a list of the sub-contractors that will be assigned to this project.	3	3	3	3	
Past Performance with District - Quality of Work and Adherence to Contract Terms - 10 points						
12	List projects completed or in progress for Mission CISD.	10	0	10	0	
HUB Certification - 0.5 points						
13	Provide documentation to assist compliance with laws and rules relating to Historically Underutilized Businesses.	0.5	0.5	0	0.5	
Proposed Schedule for Construction - 5 points						
14	Contractor's ability to adhere to construction schedule. Provide proposed schedule of construction from commencement through substantial and final completion.	5	5	1	2.5	
Financial Strength of Company - 2 points						
15	Provide a letter from your bonding company addressing the points listed in the item 15 of the Contractor's Information Statement Form.	1	1	1	1	
16	Provide a bank letter of reference with regards to the company's financial strength.	0.5	0.5	0.5	0.5	
17	Provide a statement attesting if the company or company's principals under other company names ever filed for bankruptcy.	0.5	0.5	0.5	0.5	
Thoroughness of Bid Submission and Quality of Presentation - 4.5 points						
18	Provide the Contractor's Checklist, including the documents required and the copies in the order requested. Contractor must submit everything required in project specifications including Contractor's Information Statement.	4.5	4	4.5	2	
Total Points		100	77.5	63	59	
Rank (1 is Highest)		1	2	3		

Committee Members:

Adrian Hernandez, Coordinator for Projects and Energy Management
Adan Rivera, Assistant Coordinator for Maintenance
Dora Garcia, Purchasing Coordinator
Daisy Cuevas, Purchasing Specialist

*Western Towers submitted incomplete proposal and no bid bond.

SUBJECT: Consideration and Approval Change Order #02 for Unforeseen Additional Roof Damage and Additional Fifteen (15) Delay Days for the Lee Field House Roofing Project – Raba Kistner

PRESENTER: Ricardo Rivera
Assistant Superintendent for Operations

BACKGROUND INFORMATION

Tom Landry Stadium was constructed and the Eagles played their first football game in 1977. The field house was constructed a few years later. In December of 2014 the new field house was completed, however, the new fieldhouse did not have adequate space and facilities to incorporate all the sports grade level teams. Due to this, Lee Field continues to be used for other MHS sports teams, however, much building renovations and improvements are needed primarily a new roof, new showers, new restroom facilities, new lockers and benches along with meeting rooms and may not be all inclusive. Lee Fieldhouse is also used for visiting teams and game officials along with being the fieldhouse for VMHS when they play home games.

Due to Hurricane Hanna on or about July 24, 2021 the roof structure was completely torn off causing extensive damage in the interior and exterior and the need for a new roof structure.

At the Regular Board of Trustees Meeting, held on May 12, 2021, the Board approved Raba Kistner's submission of schematic and final designs and submitted these for Administration and the Board of Trustees to review. Administration presented Consideration and Approval of Schematic and Final Roof Design for the Lee Field House Project.

Administration will use competitive sealed proposals (CSP's) as the procurement method as approved by the Board of Trustees in the February 2021 Board of Trustees meeting. This method was approved as the primary default method for projects.

Advertisements in the local newspapers were posted on May 19, 2021 and May 26, 2021. A pre-proposal meeting was held on Thursday, May 27, 2021 with proposals publicly and remotely scheduled to be opened on June 3, 2021 at 2:00 p.m.. There were no proposals submitted and Administration extended the solicitation for an additional two weeks. A second pre-proposal meeting was held Thursday, June 17, 2021 and proposals were opened on Thursday, June 24, 2021 at 2:00 p.m.. Pre-ranking of the proposals were conducted by Ms. Dora Garcia, Mr. Joel Garcia, Mr. Adrian Hernandez and Ms. Daisy Cuevas on Wednesday, July 21, 2021 at 8:30 a.m..

Pre-ranking of proposals by Administration is a district process to pre-check if all requested documents and information in the Competitive Sealed Proposal (CSP) was submitted.

However, since the district no longer has a Facilities/Environment Committee and we now use the Board of Trustees Work Shop format, Administration presents the option of presenting Approval to Accept Administrations Rankings and Enter into Negotiations in the Order of Ranking for the Lee Field House Project.

Two proposals were submitted for this project.

Company, Base bid, Number of days, Total Points and Alternates

Rio Roofing - \$444,400.00 – 180 days	Total Points	98.0
Alt.#1 \$409,500.00		98.0
Alt.#2 \$416,000.00		98.0
Alt.#2a \$410,500.00		98.0
Alt.#3 \$11,000.00 – 30 days		98.0
Rain Seal - \$535,000.00 – 150 days	Total Points	81.1
Alt.#1a \$470,000.00		82.5
Alt.#2 \$484,000.00		82.1
Alt.#2a \$440,000.00		84.7
Alt.#3 \$45,000.00 – 30 days		60.6

Initial project negotiations were held on August 17, 2021, with Mr. Hichens, Rio Roofing, Mr. Ricardo Rivera and Mr. Adrian Hernandez. During the negotiations Rio Roofing presented as their Best and Final Offer (BAFO) \$444,400.00 with no decrease in their initial proposal with 180 days of construction time from the notice to proceed (NTP).

The Board of Trustees has the option to accept this BAFO, the initial base proposal, to decline the offer and direct Administration to enter into negotiations with the next contractor or to reject all offers and re-advertise for the project using the same specifications and design or direct the engineer to re-design the project.

Raba Kistner recommends alternate #2, alternate #3 and the contingency allowance:

Alt. #2:	\$416,000.00	108 days
Alt. #3:	\$ 11,000.00	30 days
Contingency:	<u>\$ 20,000.00</u>	
Total Project:	\$447,000.00	

At the Regular Board meeting held on September 08, 2021, the Board approved Rio Roofing Best and Final Offer (BAFO) of \$447,000.00 with 210 days. Notice to Proceed was effective October 25, 2021, with substantial completion will be May 23, 2022. On the request of MCISD the general contractor was asked if they could delay working on the project until after the Thanksgiving Holiday on or about November 29, 2021 due to the Mission Eagles being in the football playoffs and may need to use the facilities. It was agreed upon by all parties.

At the Regular Board of Trustees meeting held on February 09, 2022, the Board approved Change Order #01 for the Deck Replacement and additional 45 delay days for the Lee Field House Roofing Project – Raba Kistner. If approved it will be deducted from owner's contingency allowance and the new substantial completion will be July 8, 2022. Large portions of the existing metal deck were found deteriorated during construction, thus the recommended change order.

Contingency Allowance:	\$20,000.00
Change Order #1 Roof:	<u>\$76,500.00</u>
Contingency Balance:	(\$56,500.00)

ADMINISTRATIVE CONSIDERATIONS

Raba Kistner and Rio Roofing presents, Consideration and Approval Change Order #02 for Unforeseen Additional Roof Damage and Additional Fifteen (15) Delay Days for the Lee Field House Roofing Project – Raba Kistner. If approved the new substantial completion date will be July 25, 2022.

At the Board Work Shop on Wednesday, April 06, 2022, Mr. Alejandro Folchi, Raba Kistner advised Administration that the project continues to be ahead of schedule.

There are no remaining funds available in the contingency allowance, the change order will result in a net increase of the contract amount by of Change Order #02 - \$25,080.00. If approved the new contract amount will be \$528,580.00.

FUNDING SOURCE

Local Funds

Estimated Budget \$300,000.00

RECOMMENDATION

This agenda item was presented at the Board of Trustees Workshop on Wednesday, April 06, 2022.

Administration presents Consideration and Approval Change Order #02 for Unforeseen Additional Roof Damage and Additional Fifteen (15) Delay Days for the Lee Field House Roofing Project – Raba Kistner

EXHIBIT

Change Order (CO) #02

CONTACT PERSONS

Ricardo Rivera, Assistant Superintendent for Operations
Adrian Hernandez, Coordinator for Project & Energy Management



AIA Document G701™ – 2017

Change Order

PROJECT: <i>(Name and address)</i> Lee Field House Reroofing & Repair Main Field House Roof 1802 Cleo Dawson, Mission, Texas, 78572	CONTRACT INFORMATION: Contract For: General Construction Date: September 20, 2021	CHANGE ORDER INFORMATION: Change Order Number: 002 Date: 03/24/2022
OWNER: <i>(Name and address)</i> Mission Consolidated Independent School District 1201 Bryce Drive, Mission, Texas, 78572	ARCHITECT: <i>(Name and address)</i> Raba Kistner, Inc. 1600 N. Jackson Rd., Suite #3 Pharr, Texas, 78577	CONTRACTOR: <i>(Name and address)</i> Rio Roofing, Inc. 22452 US 77 Expressway Harlingen, Texas 78552

THE CONTRACT IS CHANGED AS FOLLOWS:

(Insert a detailed description of the change and, if applicable, attach or reference specific exhibits. Also include agreed upon adjustments attributable to executed Construction Change Directives.)

The Contingency Allowance for this Project was completely utilized by Change Order No. 01 on 01/24/2022. There are no remaining funds available in the Contingency Allowance.

The Scope of Work will be increased, to replace 3,940 SF of existing deteriorated roofing components. (Re.: Proposal Request No. 002, Items 1 & 2, included as Attachment B to this Change Order) and Contractor Proposal (included as Attachment C to this Change Order).

This Change Order will result in a net increase of the Contract amount by \$25,080.00 to \$528,580 and will add 15 days to the Contract as follows:

Item 1 (Credit) - (\$ 1,220.00)	Delete plywood fastening requireat Roof Areas A & A1.
Item 2 (Add) \$ 26,300.00	Remove deteriorated plywood, 2x4 sleepers and spray foam insulation from Roof Areas A & A1 and replace these items with new rigid insulation & new 1/2" cover board (Approx 3,940 sf)

Total Add & Credits \$ 25,080.00

Total Change Order No. 1 \$ 25,080.00
Total Additional Days 15

The current Substantial Completion Date is July 8th, 2022. Fifteen (15) days will be added to this Project to complete work. The new Substantial Completion Date will be July 25th, 2022.

Please refer to the following Attachments:

- Attachment A - Field Observation Report No. 8 (5 pages)
 - Attachment B - Proposal Request No. 002 (1 page)
 - Attachment C - Contractor Proposal (1 page).
-

The original Contract Sum was	\$ 447,000.00
The net change by previously authorized Change Orders	\$ 56,500.00
The Contract Sum prior to this Change Order was	\$ 503,500.00
The Contract Sum will be increased by this Change Order in the amount of	\$ 25,080.00
The new Contract Sum including this Change Order will be	\$ 528,580.00

The Contract Time will be increased by fifteen (15) days.
The new date of Substantial Completion will be July 25th, 2022

NOTE: This Change Order does not include adjustments to the Contract Sum or Guaranteed Maximum Price, or the Contract

Time, that have been authorized by Construction Change Directive until the cost and time have been agreed upon by both the Owner and Contractor, in which case a Change Order is executed to supersede the Construction Change Directive.

NOT VALID UNTIL SIGNED BY THE ARCHITECT, CONTRACTOR AND OWNER.

Raba Kistner, Inc.

Rio Roofing, Inc.

Mission Consolidated Independent School District

ARCHITECT (Firm name)



SIGNATURE

Michael D. Hovar, AIA, RRO, LEED AP
PRINTED NAME AND TITLE

03/24/2022

DATE

CONTRACTOR (Firm name)



SIGNATURE

Hedley Hichens
PRINTED NAME AND TITLE

03/24/2022

DATE

OWNER (Firm name)

SIGNATURE

PRINTED NAME AND TITLE

DATE

Attachment A
Field Observation Report No. 8 (5 pages)

ROOF OBSERVATION REPORT



CLIENT: MCISD
 Mr. Ricardo Rivera
 520 Holland Ave.
 Mission, Texas 78572-4399

PROJECT NO.: AMB21-005-00
REPORT DATE: March 22, 2022
REPORT NO.: Eight (8)
DATE OF OBSERVATION: March 22, 2022 @ 11:45 am
RKCI ROOF OBSERVER: Alejandro Folchi
GENERAL CONTRACTOR: Rio Roofing
ROOFING CONTRACTOR: Rio Roofing
ROOFING MANUFACTURER: Siplast

Raba Kistner Consultants, Inc.
 1600 N. Jackson Rd., Suite 3
 Pharr, TX 78577
 www.rkci.com
 P 956.322.4462
 F 956.682.5487
 TBPE Firm F-3257
 TBAE Firm BR-3427

PROJECT STATUS AT-A-GLANCE

Today's Performance			
Construction Today?	<input checked="" type="checkbox"/> Yes	<input type="checkbox"/> No	If No Construction, Inspection Done? <input type="checkbox"/> Yes <input type="checkbox"/> No
Contractor Performance Issues?	<input type="checkbox"/> Yes	<input checked="" type="checkbox"/> No	
Schedule/Scope Issues?	<input type="checkbox"/> Yes	<input checked="" type="checkbox"/> No	
Impacts to Site Operations?	<input type="checkbox"/> Yes	<input checked="" type="checkbox"/> No	
Unresolved Issues:			
#	Description	Date Observed	Status
1	Provide Proposal for deck repairs and additional rigid insulation at Roof Areas A & A1 (RFP #2 issued by RKCI on 3/21/22, see below).	3/22/2022 (reported by Contractor: 3/21/2022)	In progress.

Approx. SF Completed Today:	N/A	Crew Size:	+/- 6 workmen
Weather:	Mostly sunny, 18 mph winds	Temperature:	80°F
Material Storage Condition:	Materials adequately stored and protected at designated areas.		

SUMMARY AND HIGHLIGHTS OF TODAY'S WORK

Alejandro Folchi, (PM, Raba Kistner - RKCI) visited the construction site. At the time of the visit, workmen were on their lunch break. Before I left the site, I met briefly with Adrian Hernandez (Mission CISD) and outlined my observations to him.

The metal deck replacement and the installation of the temporary roofing membrane at Areas A2 & A3 have been completed. Workmen were working on the installation of the perimeter sheet metal pouring curbs as well as other prep work - such as raising all pipes and mechanical curbs in preparation of the lightweight insulating concrete (LWIC) pour. The north perimeter the perimeter sheet metal pouring curbs appear to be mostly completed and the other roof edges appear to be quite advanced as well. In general, this Project appears to be nearly ready for receiving the lightweight insulating concrete.

During Spring Break, as workmen removed the temporary single-ply roof to prepare Roof Areas A & A1 for the LWIC, they found that the existing plywood roof deck, 2x wood sleepers and underlying spray foam insulation, once uncovered, expressed widespread and extensive damage. The most cost effective solution was to remove all existing materials above the existing metal deck, clean-up and repair the existing metal deck and install new rigid insulation and a new cover board to bring the temporary roof membrane over Roof Areas A & A1 to match the level of adjacent Roof Area A3.

Roof Area A presented a metal decking that was significantly lower than the new decking over Roof Area A3, which required an additional 3-inches of rigid insulation to bring it to the same level as Roof Area A3 (please see left portion of the roof opening depicted in Photograph 5, below). While Roof Area A1, required an additional 1-inch of rigid insulation to bring it to the same level as Roof Area A3 (see right portion of the same roof opening depicted in Photograph 5, below). Both Roof Areas, A & A1, required the installation of 1/2-inch

Securock cover board to be able install the temporary roof membrane, as the existing plywood cover board had to be removed.

This is an unforeseen condition that was discovered during the tear-off and was not included in Contractor's Scope of Work. We sent the Contractor a Request for Proposal (RFP) for the cost of the additional labor and materials. If this Proposal is acceptable, we will submit a Change Order for Mission CISD's consideration and approval.

All observed work appears to generally follow the design intent and accepted roofing practices. Debris/garbage is being removed off the roof at the end of each working day. All on-site materials were observed to be adequately raised, stored and protected, both at ground level and roof level.

Contractor to let Architect know scheduled date for lightweight concrete pour as it becomes available.

Roof Plan (sketch) below indicates the location of issues and roof areas mentioned in this report.

RABA KISTNER CONSULTANTS, INC.



Folchi, Assoc. AIA, RRC, RRO
Senior Building Envelope Consultant
Building Envelope Consulting Services

AF/mdh

Attachments: Photographs

Copies Submitted: Above (Via Email)

Distribution List				
Owner – Mission CISD	Contractor – Rio Roofing	Manufacturer – Siplast	RKCI	Consultants
Ricardo Rivera	Thomas Gonzalez	Justin Fitts	Michael D. Hovar	N/A
Adrian Hernandez	Hedley Hichens	Mark Koehler	Donato Amaya Alejandro Folchi	

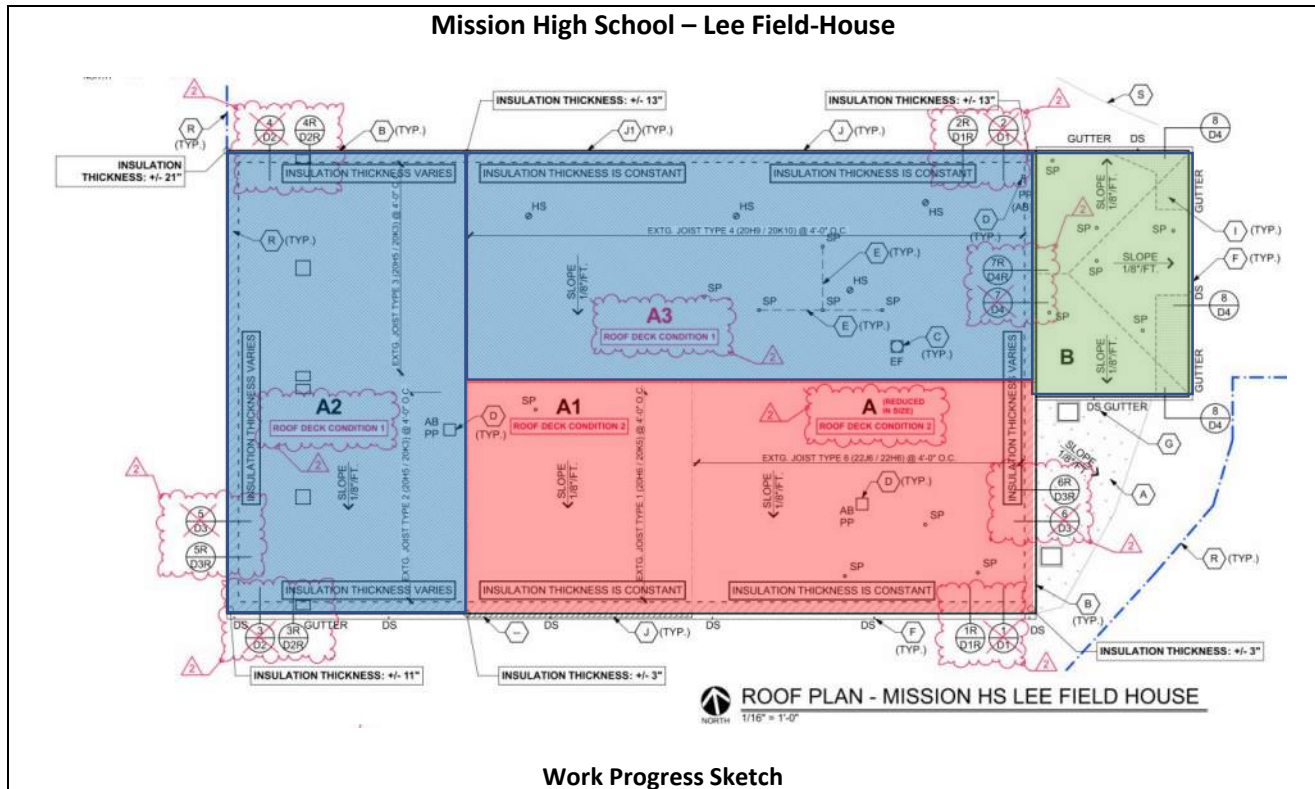

References

- -
- New metal decking, cover board and temporary roofing over replacement metal deck.**

New Insulation, Coverboard and Temporary Roofing over existing metal deck.
 - Temporary roofing over existing wood decking**



PHOTOGRAPH 1

General View of Lee Field House Roof: Installation of cover board and temporary roof membrane has been completed over the entire building. (Photograph taken from the east).

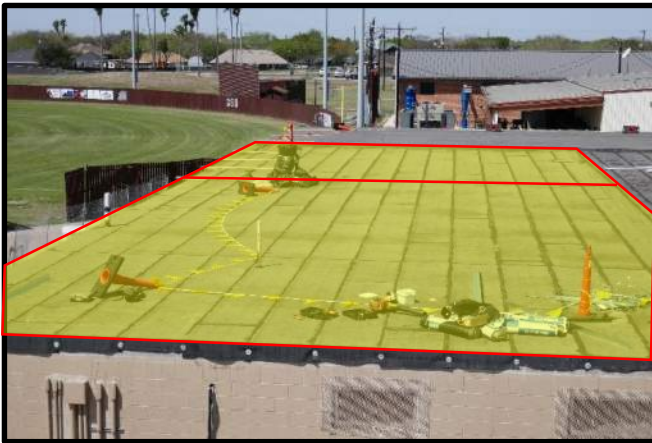

PHOTOGRAPH 2

General View of Roof Areas A & A1: Close-up view from Photograph 1. The yellow highlight sketched over the photo indicates the location of Roof Area A1 (background) and Roof Area A (foreground).

These were the two roof areas where the existing roof system had extensive deterioration and had to be removed and replaced with rigid insulation and a new cover board.

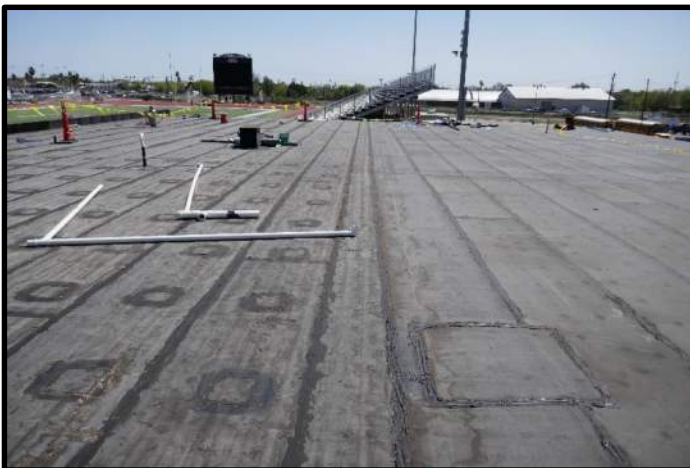

PHOTOGRAPH 3

Lee Field House: This photograph was taken facing east, at the intersection between Roof Area A3 (left) and Roof Areas A1 & A (right). The two latter Roof Areas had different deck heights and required the installation of rigid insulation to bring them to the same level as Roof Area A3.



PHOTOGRAPH 4

Photograph provided by Hedley Hichens (Rio Roofing) : Taken a few days before our visit from Roof Area A3 looking west. To the left is Roof Area A1 after the existing roof system was removed. Workmen are standing over the 1-inch polyiso (rigid) insulation while they fasten several sections of tie-in sheet metal between the two Roof Areas.



PHOTOGRAPH 5

Photograph provided by Hedley Hichens (Rio Roofing) : Taken a few days before our visit from Roof Area A3 looking south to Roof Areas A (left) and A1 (right). Note the different thicknesses that the roof system has over each metal deck. Since metal decks were set at different relative heights, they required different insulation thicknesses to align their tops.



PHOTOGRAPH 6

Roof Area A3: Mechanical curbs have been raised and covered with temporary roofing in preparation to receive the LWIC pour. In the far background, the new lightweight pour curb over the north roof edge.

Attachment B
Proposal Request No. 002 (1 page)



AIA Document G709™ – 2018

Proposal Request

PROJECT: <i>(name and address)</i> Lee Field House Reroofing & Repair Main Field House Roof 1802 Cleo Dawson, Mission, Texas, 78572	CONTRACT INFORMATION: Contract For: General Construction Date: September 20, 2021	Architect's Project Number: AMB21-005-00 Proposal Request Number: 002 Proposal Request Date: 03/22/2022
OWNER: <i>(name and address)</i> Mission Consolidated School District 1201 Bryce Drive, Mission, Texas, 78572	ARCHITECT: <i>(name and address)</i> Raba Kistner, Inc. 1600 N. Jackson Rd., Suite #3 Pharr, Texas, 78577	CONTRACTOR: <i>(name and address)</i> Rio Roofing, Inc. 22452 US 77 Expressway Harlingen, Texas 78552

The Owner requests an itemized proposal for changes to the Contract Sum and Contract Time for proposed modifications to the Contract Documents described herein. The Contractor shall submit this proposal within ten (10) days or notify the Architect in writing of the anticipated date of submission.

(Insert a detailed description of the proposed modifications to the Contract Documents and, if applicable, attach or reference specific exhibits.)

Large portions of the existing metal deck were found deteriorated during construction. In order to facilitate the Owners right to accept or reject any or all of the items included in this Proposal, the Contractor shall prepare a complete, itemized breakdown for each Item that includes the individual cost of:

- a) Materials (additions and deductions)
- b) Labor (additions and deductions)
- c) Time (additions and deductions)

for each item listed below.

Item 1 (Credit to Owner) - Delete installation of additional fasteners to increase bond between the existing plywood cover board and the metal deck at Roof Areas A and A1.

Item 2 - Remove deteriorated plywood, wood framing and spray foam insulation over Roof Areas A and A1. Repair any deteriorated metal deck, clean & prep deck and install additional polyiso insulation and cover board to match the tops of of recently installed metal decking at adjacent roof areas as follows:

- Roof Area A: install 3" of polyiso insulation (Approximately 2,400 SF)
- Roof Area A1: install 1" of polyiso insulation (Approximately 1,600 SF)
- Roof Area A & A1: install 1/2" Securock with 24 fasteners per board.

THIS IS NOT A CHANGE ORDER, A CONSTRUCTION CHANGE DIRECTIVE, OR A DIRECTION TO PROCEED WITH THE WORK DESCRIBED IN THE PROPOSED MODIFICATIONS.

REQUESTED BY THE ARCHITECT:

Michael D. Hovar, AIA, LEED AP,
RRO

PRINTED NAME AND TITLE

Attachment C
Contractor Proposal (1 page)

March 22, 2022

Raba Kistner, Inc.
1600 North Jackson Rd, Ste. 3
Pharr, TX 78577

Mission CISD Lee Field House Reroofing and Main Field House Roof Repairs
Mission, TX

Re: Work Changes Proposal 02

Item 1- Roof Removal

Proposal: We propose to remove and replace approximately 4,000 square feet of existing roof down to existing metal deck. Includes all existing spray foam, 2x4 battens, and plywood.

Item 1 (Credit to Owner)- Delete plywood fastening at area of tear-off.

Labor: \$ 400.00
Material: \$ 820.00
Credit to Owner: \$ 1,220.00

Item 2- Remove deteriorated roof system down to existing metal deck, patch and repair all corroded deck and install approximately 16 SQ of 1" polyiso and 24 SQ of 3" polyiso in an attempt to bring all of the differing deck heights to the same plane. Install and fasten 40 SQ of 1/2" Securock at a rate of 24 per board (1 per 1.34 sf)

Labor: \$ 9,600.00
Material: \$ 16,700.00
Total Add \$ 26,300.00

Total Change Order Proposal:

Add: \$ 25,080.00

Time: Add 15 days

Thank you,



Hedley Hichens

SUBJECT: Approval of Budget Amendment for the Month of April 2022

PRESENTER: Joel Garcia, Assistant Superintendent for Finance

BACKGROUND INFORMATION

In accordance with TEA budget and accounting procedures guidelines, the District's official budget includes the General Fund and Debt Service. The adoption of the budgets associated with these funds, and subsequent amendments, should be approved by the Board of Trustees. The authority to approve a budget or a budget amendment for a grant program, however, lies with the granting agency and not with the District's Board.

The budget amendments are broken down into the following two categories:

1. Programmatic or policy changes – amendments that are necessary because of policy changes or program revisions that increase/decrease the budget.
2. Adjustment of original estimates – amendments that are necessary because the original amounts required adjustments but do not increase/decrease the budget.

ADMINISTRATIVE CONSIDERATIONS

All requests for budget amendments have been reviewed and are justified for the programmatic or policy changes and adjustments of original estimates.

As presented in the budget update, Administration recommends the amendment of the current budget to reduce revenues and expenditures so that the budget aligns with the projected state revenue.

In addition, the amendment also provides the funding necessary for the Tom Landry Stadium visitor's side repairs.

FUNDING SOURCE AND AMOUNT

- Reduce revenues and expenses from current budget.
 - The district will pay instructional salaries at secondary campuses using ESSER II funding.
 - Additional savings in payroll costs.
- Increase general fund by \$183,417 for the Tom Landry Stadium Visitor side repairs; total cost of repairs is estimated at \$489,000.

RECOMMENDATION:

Approval of Budget Amendment for the Month of April 2022

CONTACT PERSONS

Joel Garcia, Assistant Superintendent for Finance
Anna Zuniga, CPA, Director for Finance

Mission CISD
 Combined Statement of Revenues, Expenditures and Changes in Fund Balances
 Budget and Actual (Unaudited & Unadjusted)
General Fund (100-199)
Comparison Years
 School Year 2021 2022

100		2021 2022			
200		Original Budget	Current Budget	Amendment Needed	Amended Budget
REVENUES					
5700	Local & Intermediate Sources	27,728,439	27,728,439	(49,077)	27,679,362
5800	State Program Revenues	130,446,452	130,446,452	(16,233,279)	114,213,173
5900	Federal Program Revenues	22,687,952	22,687,952	101,310	22,789,262
6000	Total Revenues	180,862,843	180,862,843	(16,181,046)	164,681,797
EXPENDITURES					
11	Instruction and Instructional Related Services	94,057,501	72,464,526	(18,645,447)	53,819,079
12	Instructional Resources & Media Services	2,516,394	2,553,161	(80,979)	2,472,182
13	Curriculum & Instructional Staff Development	2,254,646	2,148,059	270,416	2,418,475
21	Instructional Leadership	2,898,225	2,872,390	90,637	2,963,027
23	School Leadership	9,693,932	9,778,449	(112,839)	9,665,610
31	Guidance, Counseling & Evaluation Services	6,190,714	6,168,967	(76,313)	6,092,654
32	Social Services	587,220	587,220	794	588,014
33	Health Services	1,973,169	1,974,424	(100,797)	1,873,627
34	Student (Pupil) Transportation	4,981,181	6,481,181	142,394	6,623,575
35	Food Services	14,046,270	15,337,531	1,159,006	16,496,537
36	Co-Curricular	7,439,336	8,469,301	464,698	8,933,999
41	Administrative Support Services	5,899,249	6,050,081	255,259	6,305,340
51	Plant Maintenance & Operations	19,574,382	34,487,282	15,761	34,503,043
52	Security and Monitoring Services	3,522,854	3,556,603	(75,704)	3,480,899
53	Data Processing Services	3,025,432	3,335,115	255,351	3,590,466
61	Community Services	399,873	399,873	(48,866)	351,007
71	Principial on Long Term Debt	1,036,320	1,036,320	-	1,036,320
72	Interest on Long Term Debt	-	-	-	-
81	Facilities Acquisitions & Construction	450,065	8,709,628	489,000	9,198,628
95	Fiscal Agent Payments	20,000	20,000	-	20,000
99	Payments to Juvenile Justice Alternative	296,080	296,080	-	296,080
	Total Expenditures	180,862,843	186,726,191	(15,997,629)	170,728,562
	Excess (Deficiency) of Revenues Over (Under)	-	(5,863,348)	(183,417)	(6,046,765)
Expenditures					
7900	Other Resouces	16,613,295	16,613,295	-	16,613,295
8900	Other (Uses)	(16,613,295)	(18,022,997)	-	(18,022,997)
9000	Net Change in Fund Balance	-	(7,273,050)	(183,417)	(7,456,467)
	Fund Balance June 1	80,898,169	80,898,169	-	80,898,169
1300	<i>Estimated Ending Fund Balance</i>	80,898,169	73,625,119	-	73,441,702

SUBJECT: Approval of Close Up Leadership Conference in Washington, DC

PRESENTER: Dr. Sharon Roberts, Deputy Superintendent for Curriculum and Instruction

BACKGROUND INFORMATION

Close Up's High School Programs are designed to give students and educators an inside look at democracy in action. Using the nation's capital as a living classroom, participants get a "close up" view of government - interacting with the people, processes, and places that make this federal city so unique.

In addition to the one-of-a-kind **Washington DC High School Program**, they customize trips for groups from around the country that are tailor-made to meet the specific needs of their group. Since 1971, over 825,000 students and educators have graduated from this experiential program. In addition, each year, they welcome students from every state and every U.S. territory on the fast-paced and educational programs in Washington, DC.

Approximately 10 students will have the opportunity to attend the Close-Up Leadership Conference in Washington, DC June 20-25, 2022. Mrs. Nancy Villarreal, FaCE & Migrant Coordinator will supervisor students on this trip.

ADMINISTRATIVE CONSIDERATIONS

Approval of the Close-Up Leadership Conference in Washington, DC, June 20-25, 2022

FUNDING SOURCE/AND AMOUNT

Title I Part C Migrant Funds, estimated cost \$23,000

RECOMMENDATION

Approval of Close Up Leadership Conference in Washington, DC, June 20-25, 2022

CONTACT PERSON(S)

Mrs. Kim Risica, Executive Director for Special Programs & School Improvement
Mrs. Nancy Villarreal, FaCE and Migrant Coordinator

SUBJECT: Approval of TSTC Migrant Academic Achievement Residency Summer Experience (MAARS)

PRESENTER: Dr. Sharon Roberts, Deputy Superintendent for C&I

BACKGROUND INFORMATION:

The Migrant Academic Achievement Residency Summer Experience (MAARS) is a 4-week residential summer instructional program that offers various opportunities to qualifying migrant students. (June 12, 2022-July 22, 2022)

The opportunities are to:

- Offer a 6-week residential summer instructional program on the performing party campus to assist qualifying migrant students in earning additional high school graduation credits. Should TSTC's COVID-19 policy require the program not be held in-person, the program will be implemented virtually.
- Engage MAARS participants in career exploration opportunities through the available technical programs on the performing party campus.
- Engage MAARS participants in college readiness and leadership seminars to further their educational goals.
- Have the authority to discipline students who fail to adhere to all TSTC's and/or MAARS's policies and procedures. Disciplinary action may include, but not be limited to, the student's incentive stipend being delayed or the student being removed from the program.
- Provide MAARS participants with a tour of colleges and universities.
- Provide MAARS participants with community service opportunities as well as cultural events.
- Provide MAARS participants with room and board.
- Provide bi-weekly \$100.00 incentive to participants that meet all requirements during program.
- Provide \$1,000.00 to participants upon successful completion of the program.

Approximately 6 students will have the opportunity to attend the MAARS program.

ADMINISTRATIVE CONSIDERATIONS

Approval of TSTC Migrant Academic Achievement Residency Summer Experience (MAARS)

FUNDING SOURCE/AND AMOUNT

Title I Part C Migrant Funds, estimated cost \$30,000.00

RECOMMENDATION

Approval of TSTC Migrant Academic Achievement Residency
Summer Experience (MAARS)

CONTACT PERSON(S)

Mrs. Kim Risica, Executive Director for School Improvement & School Imp.
Mrs. Nancy Villarreal, FaCE & Migrant Coordinator

SUBJECT: Approval of UTRGV Migrant University Summer Experience (MUSE)

PRESENTER: Dr. Sharon Roberts, Deputy Superintendent for C&I

BACKGROUND INFORMATION

The Migrant University Summer Experience (MUSE) is a 5-week residential summer instructional program that offers various opportunities to qualifying migrant students. (June 6, 2022 to July 8, 2022)

The opportunities are:

- instruction leading to high school credit accrual;
- an on-campus university residential experience;
- professional workplace and career exploration internships;
- college readiness and leadership seminars;
- a tour of Texas universities;
- concluding graduation ceremony;
- living allowances; and
- follow-up on pre-college seminars during the following academic year

Approximately 10 students will have the opportunity to attend the MUSE program.

ADMINISTRATIVE CONSIDERATIONS

Approval of the UTRGV Migrant University Summer Experience (MUSE)

FUNDING SOURCE/AND AMOUNT

Title I Part C Migrant Funds, estimated cost \$53,000.00

RECOMMENDATION

Approval of UTRGV Migrant University Summer Experience (MUSE)

CONTACT PERSON(S)

Mrs. Kim Risica, Executive Director for Special Programs & School Improvement
Mrs. Nancy Villarreal, FaCE & Migrant Department

SUBJECT: Approval of Summer Programs for 2022

PRESENTER: Dr. Sharon Roberts, Deputy Superintendent for Curriculum & Instruction
Kim Risica, Executive Director for Special Programs & School Improvement

BACKGROUND INFORMATION

The proposed Summer School Programs will provide accelerated instruction, supplemental instruction, and credit recovery programs for all students interested in attending and/or meeting qualifications in grades 1-12. In addition, the program also provides the required Summer Bilingual Education (grades PK and K) and STAAR End of Course for Secondary.

ADMINISTRATIVE CONSIDERATIONS

Summer School Programs will be held at the following three (3) elementary campuses: *Alton* (Salinas, Cantu, Waitz and Cavazos), *Midkiff* (Mims, Castro and Bryan), *Pearson* (Escobar Rios, Marcell, O'Grady and Leal), and one jr. high campus: *Alton Memorial Jr. High* (R. Cantu Jr. High, K. White Jr. High and Mission Jr. High), At the high school level both *Veterans Memorial High School* and *Mission High School* will host their own programs which will be overseen by the respective Deans Of Instruction. Mission Collegiate High School students needing to attend summer school will be allowed to attend at either of the two high school sites. Most programs will operate Monday through Thursday through the month of June.

FUNDING SOURCE/AND AMOUNT

Programs planned for eligible students will be made available through various funding sources: Migrant funds \$50,000; Individuals with Disabilities Act, \$70,000; CTE, \$25,000; CCMR, \$10,000; State Compensatory Education/Title I \$600,000; State Bilingual, \$75,000.
Estimated cost: \$830,000.00

RECOMMENDATION

Approval of Summer Programs for 2022

CONTACT PERSON(S)

Dr. Sharon Roberts, Deputy Superintendent for Curriculum & Instruction
Francisca Cruz, Executive Director for SPED/504/RTI/Dyslexia
Edilberto Flores, Executive Director for Pre-K-12 (MHS)
Cynthia Wilson, Executive Director for Pre-K-12 (VMHS)
Kim Risica, Executive Director for Special Programs & School Improvement
Angelina Martinez, Bilingual/ESL Director
John Roger Hill, Curriculum Director
Sergio Pena, CTE Director

21-22 Elementary Summer Programs

Campus	Program	Inservice/ Work Day	Staff Work Day	Days of Week	Student Start Date	Instructional Hours	Student End Date	Staff End Date
Midkiff Elem. Alton Elem. & Pearson Elem.	Elementary Summer STREAM Camp (1 st -5 th)	May 30 8:00 am – 12:00 pm	Paras 7:00 am-1:00 pm Teachers 7:45 am-12:45 pm Facilitator/Lead 7:00 am-1:00 pm *Alt. End time 4:30 pm	Week 1 Tuesday- Friday Weeks 2-4 Monday- Thursday	May 31	8:00 am-12:30 pm	June 23	June 23
Midkiff Elem. Alton Elem. & Pearson Elem.	PK & K Bilingual/ESL Program	May 30 8:00 am – 12:00 pm	Paras 7:00 am-4:30 pm Teachers 7:45 am-4:15 pm	Week 1 Tuesday- Friday Weeks 2-4 Monday- Thursday	May 31	8:00 am – 4:00 pm	June 23	June 23
Midkiff Elem.	Elementary Special Ed ESY	May 30 8:00 am – 12:00 pm	Paras 7:00 am-1:00 pm Teachers 7:45 am-12:45 pm	Week 1 Tuesday- Friday Weeks 2-4 Monday- Thursday	May 31	8:00 am-12:30 pm	June 23	June 23
Campus Pull-out Midkiff Elem. Alton Elem. & Pearson Elem.	Project Smart	May 30 8:00 am – 12:00 pm	Teachers 7:45 am – 12:45 pm	Week 1 Tuesday- Friday Weeks 2-4 Monday- Thursday	May 31	8:00 am – 12:30 pm	June 23	June 23

Home Education Program	Migrant – A Bright Beginnings	May 30 8:00 am – 12:00 pm	Teachers 7:45 am – 12:45 pm	Week 1 Tuesday-Friday Weeks 2-4 Monday-Thursday	May 31	8:00 am – 12:30 pm	June 23	June 23
Elementary	Elementary Robotics Enrichment	TBD	TBD	TBD	4 days	June 2022	TBD	TBD
Elementary	Elementary Maker Space Camp	TBD	TBD	TBD	4 days	June 2022	TBD	TBD



21-22 Junior High Summer Programs

Campus	Program	Inservice/ Work Day	Staff Work Day	Days of Week	Student Start Date	Instructional Hours	Student End Date	Staff End Date
Alton Memorial Jr. High	Extended Year Summer Program (Gr. 6-8)	May 30 8:00 am – 12:00 pm	Paras 7:00 am–1:00 pm Teachers 7:45 am–12:45 pm Facilitator/Lead 7:00 am–1:00 pm	Week 1 Tuesday-Friday Weeks 2-4 Monday-Thursday	May 31	8:00 am -12:30 pm	June 23	June 23
Alton Memorial Jr. High	UTRGV STEM Camp 6 th -8 th Newcomer Camp	May 30	Teacher 7:45 am–12:45 pm	Monday - Thursday	June 6	8:00 am – 12:30 pm	June 16	June 16
UTRGV	Tex Prep Pre-Freshman Engineering Program (Gr.7-8)			Monday-Friday	June 6	1:00 pm to 5:50 pm	July 20	July 20
Alton Memorial Jr. High Campus Pull-out	Junior High Project Smart	May 30 8:00 am – 12:00 pm	Teachers 7:45 am–12:45	Week 1 Tuesday-Friday Weeks 2-4 Monday-Thursday	May 31	8:00 am – 12:30 pm	June 23	June 23
Alton Memorial Jr. High	Jr. High School Special Education ESY	May 30 8:00 am – 12:00 pm	Paras 7:00 am–1:00 pm Teachers 7:45 am–12:45 pm	Week 1 Tuesday-Friday Weeks 2-4 Monday-Thursday	May 31	8:00 am -12:30 pm	June 23	June 23

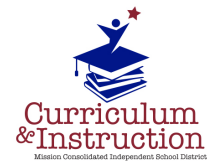

21-22 High School Summer Programs

Campus	Program	Inservice/ Work Day	Staff Work Day	Days of Week	Student Start Date	Instructional Hours	Student End Date	Staff End Date
Mission High School/Veterans Memorial High School *Each respective Dean will oversee their own program for summer admin stipend	Summer School Program/Credit Recovery	May 30 Inservice/ Workday/ Registration 8:00 – 12:00	Paras 8:00 am-2:00 pm Teachers 8:45 am-1:45 pm Facilitator/Lead 8:00 am-2:00 pm	Week 1 Tuesday - Friday Weeks 2-4 Monday- Thursday	May 31 (Sem.1) June 13 (Sem.2)	9:00 am-1:30 pm	June 9 (Sem.1) June 23 (Sem.2)	June 23
Mission High School/Veterans Memorial High School *Each respective Dean will oversee their own program for summer admin stipend	EOC Program	May 30 Inservice/ Workday/ Registration 8:00-12:00	Paras 8:00 am-2:00 pm Teachers 8:45 am-1:45 pm Administrator 8:00 am-2:00 pm	Week 1 Tuesday- Friday Weeks 2-4 Monday- Thursday	May 31	9:00 am-1:30 pm	June 23 (last day of testing)	June 23 89
STC	Dual Enrollment Academies with STC	N/A	N/A	Monday- Friday	June 6 (Sem. 1) July 13 (Sem. 2)	Times vary	July 8 (Sem. 1) Aug. 12 (Sem. 2)	N/A
Veterans Memorial High School	STC Dual Enrollment	N/A	N/A	Monday – Thursday	May 31	TBD	TBD	N/A



21-22 High School Summer Programs

Campus	Program	Inservice/ Work Day	Staff Work Day	Days of Week	Student Start Date	Instructional Hours	Student End Date	Staff End Date
Mission High School	MHS Eagle T-STEM Academy/ CTE ECA Summer Bridge	N/A	Staff 7:45 am-3:45 pm	Monday- Thursday	July 25	8:00 am-3:30 pm	July 29	July 29
Veterans Memorial High School	VMHS Patriot Academy ECHS Summer Bridge (Tentative)	N/A	Staff 7:45 am-3:45 pm	Monday- Wednesday	Summer 2022	8:00 am-3:30 pm	Summer 2022	Summer 2022 90
Mission Collegiate High School	Summer Bridge Program	N/A	Staff 7:45 am-3:15 pm	TBD	Summer 2022	8:00 am-3:00 pm	Summer 2022	Summer 2022
Veterans Memorial High School	High School Special Education ESY	May 30 Inservice/ Workday 8:00 am to 12:00 pm	Paras 8:00 am-2:00 pm Teachers 8:45 am-1:45 pm	Week 1 Tuesday - Friday Weeks 2-4 Monday- Thursday	May 31	9:00 am-1:30 pm	June 23	June 23
Veterans Memorial High School	SCADE Welding	May 30	Staff 8:00 am-4:00 pm	Monday- Thursday	June 6	8:00 am-4:00 pm	August 4	August 12
Mission High School	CTE EC Welding	STC STAFF	8:00 am-12:30 pm	Monday - Thursday	July 13	8:30 am –11:00 am	August 12	August 12
Mission High School/Veterans Memorial High School	UTRGV STEM Camp for Emergent Bilinguals	May 30 Inservice/ Workday 8:00 am – 12:00 pm	8:45 am – 1:45 pm	Monday- Thursday	June 6	9:00 am – 1:30 pm	June 16	June 16

SUBJECT: Approval for Out-of-State Trip for Destination Imagination Teams from Veterans Memorial High School and Waitz Elementary School Advancing to Global Finals in Kansas City, MO.

PRESENTER: Dr. Sharon Roberts, Deputy Superintendent for Curriculum and Instruction

BACKGROUND INFORMATION

Six Mission CISD Teams from VMHS, KWJHS, Bryan Elementary, Alton Elementary, and Waitz Elementary competed in the Lone Star Finals Destination Imagination Tournament in Arlington on March 25-26, 2022. At this tournament, a team from Waitz Elementary placed 8th and Veterans Memorial placed 2nd, earning each team the honor of advancing to Global Finals Kansas City, Missouri on May 21-24, 2022.

ADMINISTRATIVE CONSIDERATIONS

Approval for Out-of-State Trip for Destination Imagination Teams from Veterans Memorial High School and Waitz Elementary School Advancing to Global Finals in Kanas City Missouri.

FUNDING SOURCE/AND AMOUNT

199-36-6411-0DI-112-21-0-00	\$ 2,400
199-36-6412-0DI-112-21-0-00	\$ 14,450
199-36-6411-0DI-002-21-0-00	\$ 4,400
199-36-6412-0DI-002-21-0-00	\$ 14,600
	<u>\$ 35,850</u>

RECOMMENDATION

Approval for Out-of-State Trip for Destination Imagination Teams from Veterans Memorial High School and Waitz Elementary School Advancing to Global Finals in Kanas City Missouri.

CONTACT PERSON(S)

Dr. Sharon Roberts, Deputy Superintendent for Curriculum and Instruction
John Roger Hill, Curriculum Director
Adelina Alaniz, Coordinator for Advanced Academic Services

SUBJECT: Approval to Accept Final Design for the Culinary Arts Laboratory at Mission High School Project – PBK Architects

PRESENTER: Ricardo Rivera, Assistant Superintendent for Operations

BACKGROUND INFORMATION

The CTE program and Mission High School are establishing a culinary arts lab at MHS similar to one currently at VMHS. Due to the size of the project, the fire code requirements for fire suppression systems due to cooking equipment, mill-work, electrical and plumbing requirements design/engineering professional services will be required.

Administration will use competitive sealed proposals (CSP's) as the procurement method as approved by the Board of Trustees in the February 2021 Board of Trustees meeting. This method was approved as the primary default method for projects.

At the Regular Board of Trustees meeting held on August 11, 2021 the Board approved the project, proposed budget and utilizing the on-call professional services for the Culinary Arts Laboratory at Mission High School Project – PBK Architects. PBK Architects estimated project cost is \$250,000.00.

At the Regular Board of Trustees meeting held on February 09, 2022, the Board approved Schematic Design for the Culinary Arts Laboratory at Mission High School Project.

Schematic Design:

Rough sketches that develop a feasible conceptual design of the project.

Construction Documents:

Communicating the design intent through further refinement of the written and graphic representation of all building materials, components and equipment that can be quantified and useful to contractors.

ADMINISTRATIVE CONSIDERATIONS

PBK Architect has continued to meet with MCISD Staff and Administration on the designs, thus administration will be presenting Approval to Accept Final Design for the Culinary Arts Laboratory at Mission High School Project – PBK Architects. Designs have been reviewed and approved by staff. When approved Administration will advertise for proposals.

FUNDING SOURCE

Local Fund

Est. Project Budget:	\$250,000.00
Project Contingency 20%:	\$ 50,000.00
Est. Professional Services 12%:	<u>\$ 30,000.00</u>
Est. Total Project Cost:	\$330,000.00

RECOMMENDATION

This agenda item was presented at the Board of Trustees Workshop on Wednesday, April 06, 2022.

Administration is presenting Approval to Accept Final Design for the Culinary Arts Laboratory at Mission High School Project – PBK Architects.

EXHIBIT:

Final Design

CONTACT PERSONS

Ricardo Rivera, Assistant Superintendent for Operations

Adrian Hernandez, Coordinator for Project & Energy Management

MCISD MISSION HIGH SCHOOL CULINARY ARTS CLASSROOM RENOVATION



BOARD MEMBERS

JERRY ZAMORA - PRESIDENT
 VERONICA "BETTY" R. MENDOZA - VICE PRESIDENT
 ROY VELA - SECRETARY
 PETRA B. RAMIREZ - BOARD MEMBER
 MINNIE R. RODGERS - BOARD MEMBER
 JUAN M. GONZALEZ - BOARD MEMBER
 IRIS IGLESIAS - BOARD MEMBER

DR. CAROLINA G. PEREZ - SUPERINTENDENT OF SCHOOLS

SHEET INDEX

ARCHITECTURAL	EXISTING CONDITIONS OVERALL PLAN & DEMOLITION PLAN
A-101	NEW FLOOR PLAN
A-102	RCP
A-103	
MECHANICAL	MECHANICAL PLAN
M2.01	
ELECTRICAL	ELECTRICAL SYMBOLS AND ABBREVIATIONS
E-001	ELECTRICAL SITE PLAN
E-101	ELECTRICAL PLANS
E-201	ELECTRICAL ONE LINE DIAGRAM SCHEDULES & DETAILS
E-501	
PLUMBING	PLUMBING SYMBOLS AND ABBREVIATIONS
P0.01	PLUMBING PLAN
P2.01	



ARCHITECT PBK Architects, Inc.
 HOUSTON
 11 Greenway Plaza, 22nd Floor
 Houston, TX 77046
 713-965-0688 P
 713-961-4571 F
 TX Firm: BS-1638



MCISD - MISSION HS CULINARY ARTS

1802 CLEO DAWSON ST
 MISSION, TX 75722
 CONSTRUCTION DOCUMENTS

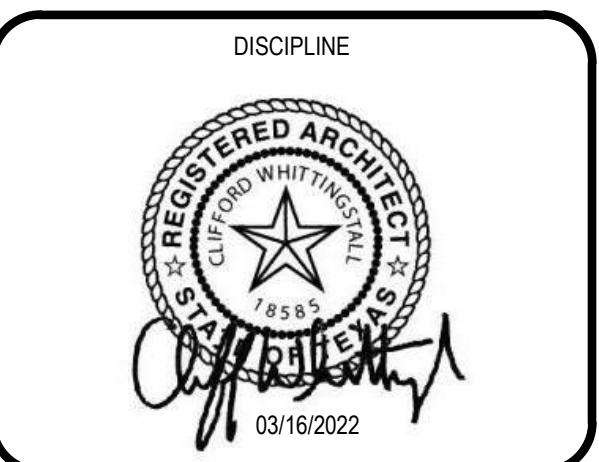
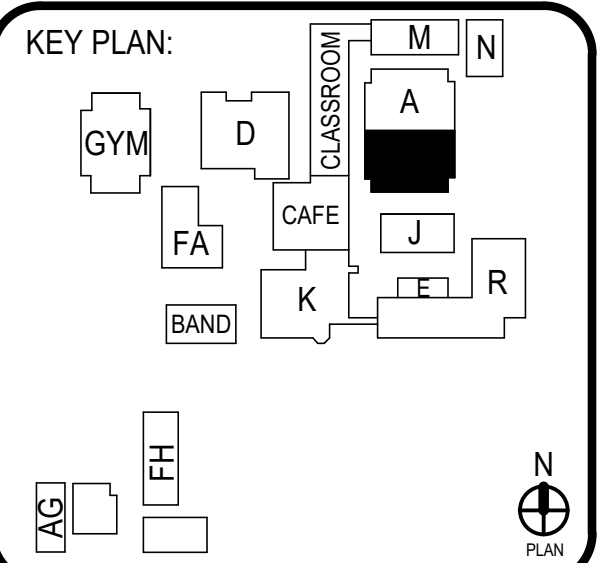

CLIENT		PROJECT NUMBER	
DATE	PROJECT	PROJECT	PROJECT
YYYY/MM/DD	[Client Name]	Number	Number

CONSTRUCTION DOCUMENTS
 BUILDING NUMBER
 COVER SHEET

G-000

COVER SHEET
 G-000
 FOR BLUEBRAIN LABELING: OOR
 File Path: C:\Users\dalvarez\Documents\Mission HS - Culinary Arts - Daniel Ramirez\KZ265.rvt
 CHECKED BY: Daniel Ramirez
 DRAWN BY: Daniel Ramirez
 Author
 Plot Stamp:
 3/16/2022 2:57:18 PM

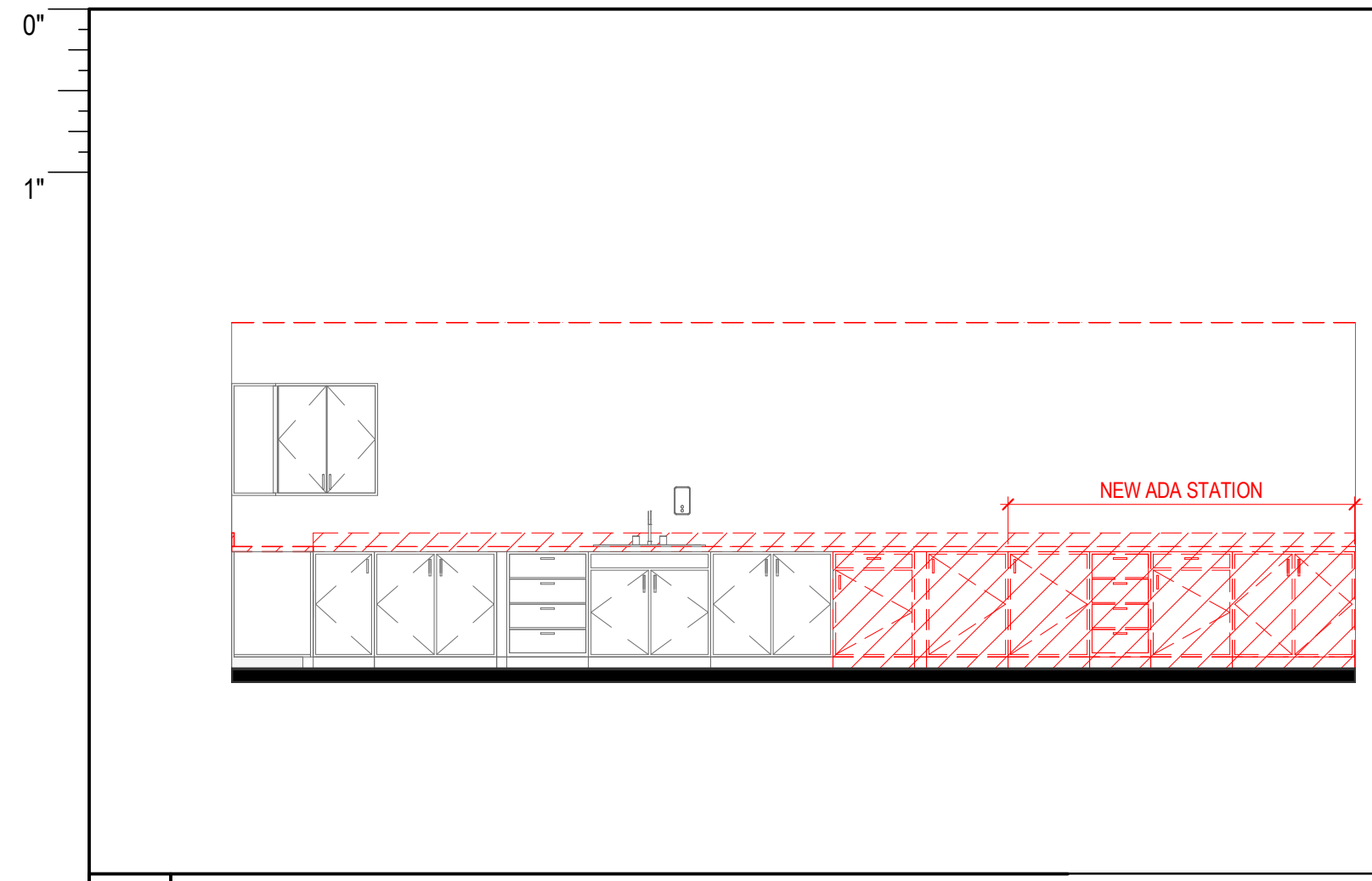

5 DEMOLITION ELEVATION
1/4" = 1'-0"

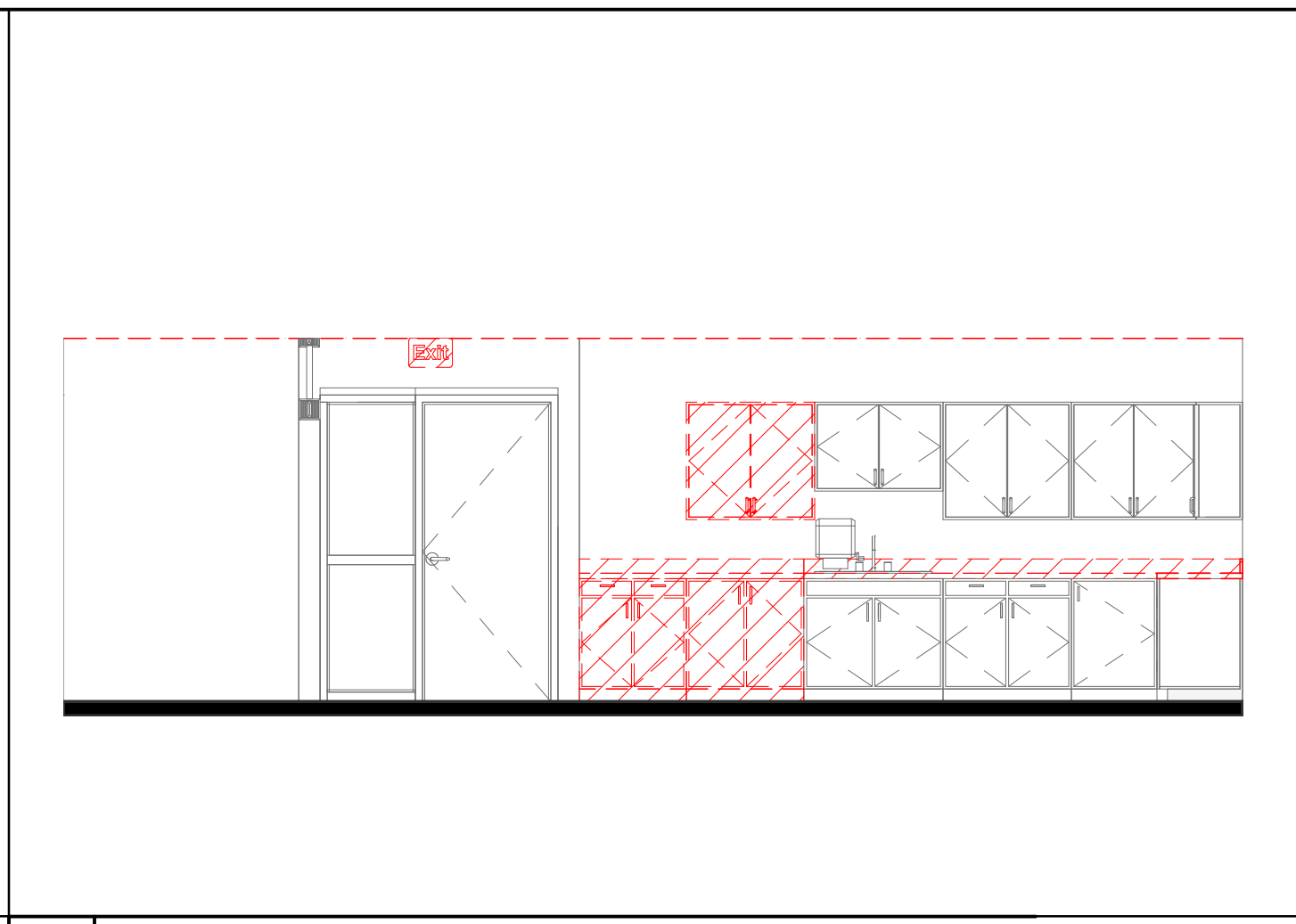

4 DEMOLITION ELEVATION
1/4" = 1'-0"

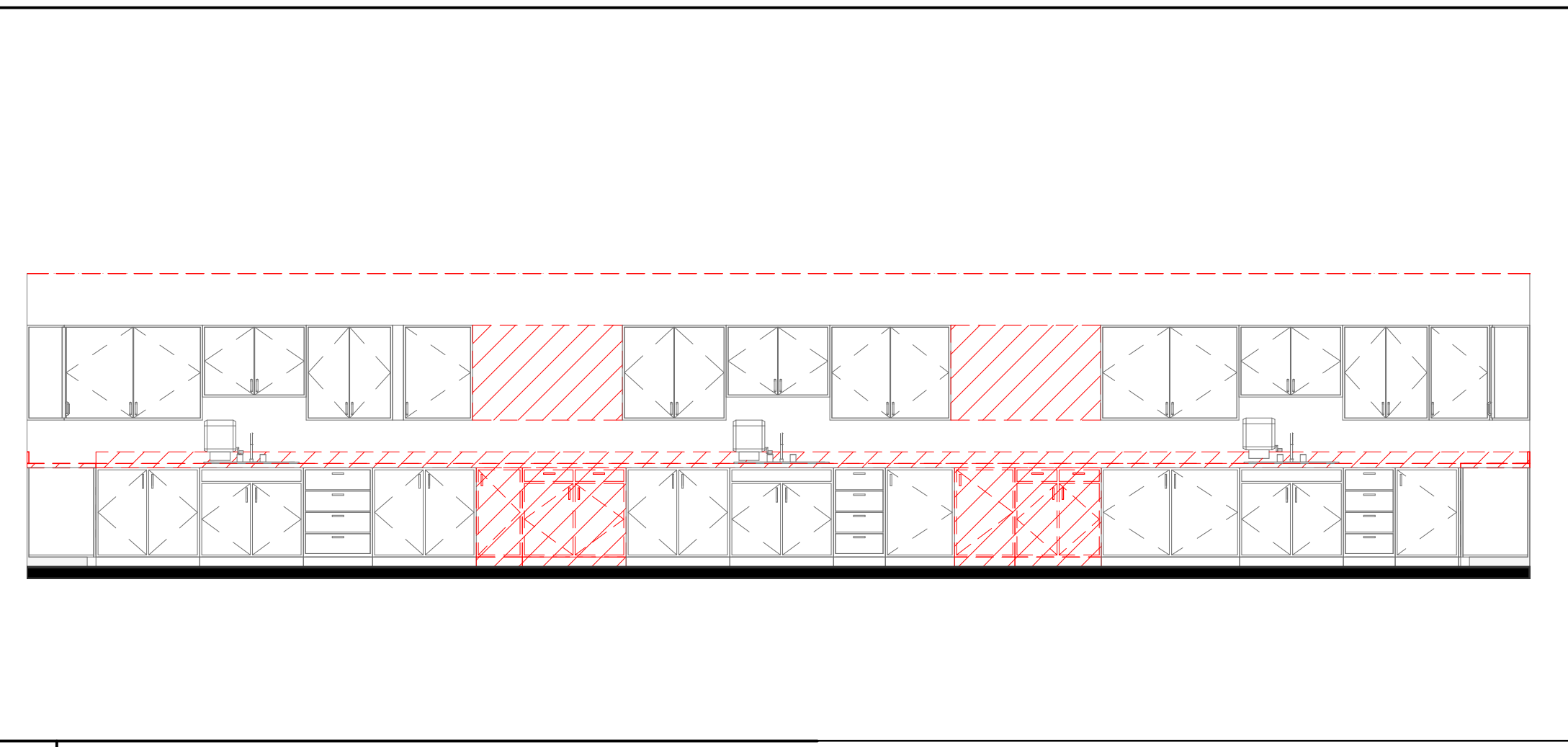

3 DEMOLITION ELEVATION
1/4" = 1'-0"

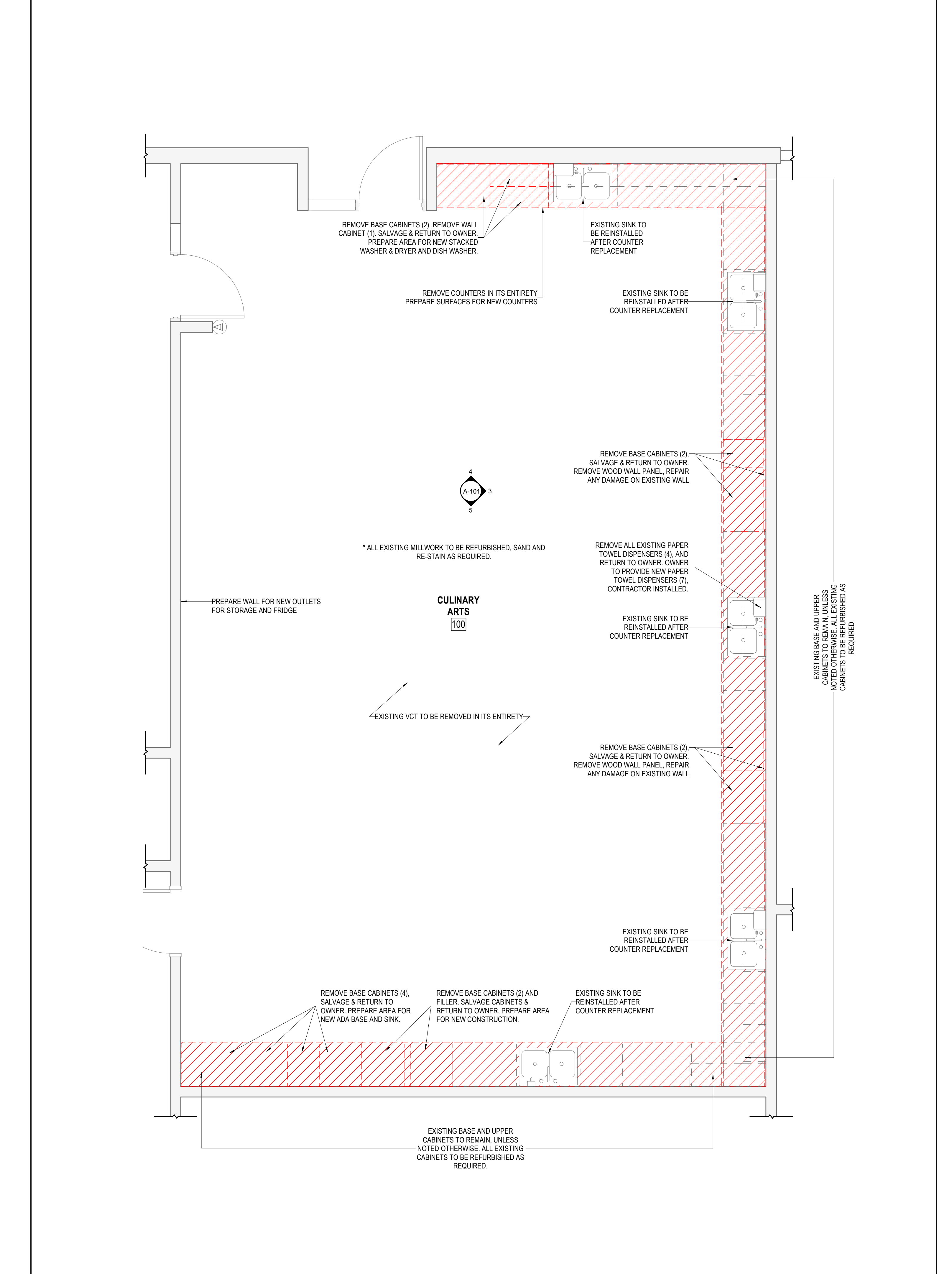

2 DEMOLITION FLOOR PLAN
3/8" = 1'-0"

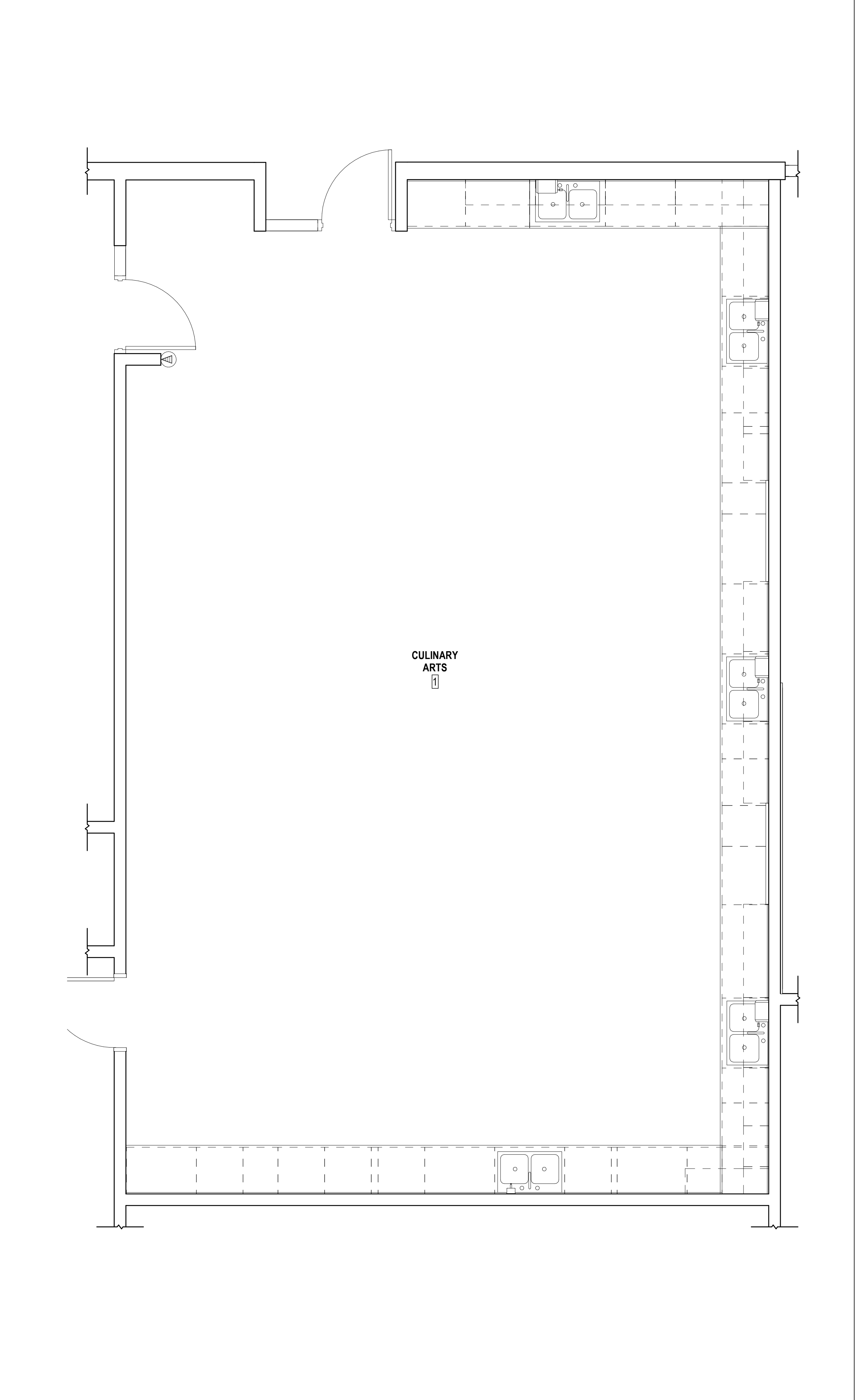

1 EXISTING CONDITIONS OVERALL
3/8" = 1'-0"

GENERAL DEMOLITION NOTES

1. DEMOLITION PLANS INDICATE SOME OF THE SCOPE OF WORK INVOLVED FOR THE DEMOLITION PHASE OF THIS PROJECT. CONTRACTOR SHALL REVIEW ALL SHEETS FOR ADDITIONAL DEMOLITION SCOPE.
2. CONTRACTOR SHALL VERIFY EXISTING SITE AND BUILDING CONDITIONS AND DIMENSIONS IN THE FIELD PRIOR TO DEMOLITION ACTIVITIES AND WORK.
3. CONTRACTOR SHALL NOTIFY ARCHITECT OF ANY DISCREPANCIES IN WRITING.
4. CONTRACTOR SHALL NOTIFY ARCHITECT AND OWNER OF ANY POSSIBLE ASBESTOS CONTAINING MATERIALS DISCOVERED BEFORE PROCEEDING WITH WORK. PROTECT INTERIOR CONSTRUCTION TO REMAIN DURING DEMOLITION AND CONSTRUCTION.
5. CONTRACTOR SHALL OBTAIN ALL NECESSARY PERMITS BEFORE COMMENCING WORK.
6. AFTER AWARD OF THE CONTRACT, CHANGE ORDER REQUESTS FOR ADDITIONAL MONEY WILL NOT BE APPROVED IF THE WORK COULD HAVE BEEN ANTICIPATED DURING A SITE VISIT BY THE CONTRACTOR.
7. CONTRACTOR SHALL NOT SCALE DRAWINGS.
8. CONTRACTOR SHALL PROVIDE ALL NECESSARY TEMPORARY SHORING, TEMPORARY BRACING, AND OR TEMPORARY SUPPORTS AS REQUIRED TO MAINTAIN STRUCTURAL INTEGRITY OF EXISTING STRUCTURE TO REMAIN AND OR EXISTING BUILDING ELEMENTS TO REMAIN.
9. CONTRACTOR IS TO VERIFY THE EXACT LOCATION OF ALL EXISTING UTILITIES PRIOR TO DEMOLITION ACTIVITIES AND WORK.
10. CONTRACTOR SHALL REMOVE TRASH AND DEBRIS REGULARLY AS NECESSARY TO ELIMINATE INTERFERENCE WITH ROADS, STREET, WALKS, AND ALL OTHER ADJACENT FACILITIES.
11. CONTRACTOR SHALL REMOVE TRASH AND DEBRIS FROM THE SITE ON A DAILY BASIS.
12. CONTRACTOR IS RESPONSIBLE FOR CONSTRUCTION OF TEMPORARY DUST AND OR SOUND PARTITION BETWEEN CONSTRUCTION AREA AND AREAS NOT IN SCOPE AS NECESSARY. DEMOLITION ACTIVITIES SHALL BE PERFORMED AS TO PRODUCE MINIMAL DISTURBANCE TO EXISTING FACILITY AND OCCUPANTS (I.E. MINIMIZE EXCESSIVE AND PROLONGED NOISE LEVELS AND DUST).
13. CONTRACTOR SHALL REPAIR, REPLACE, OR PATCH EXISTING BUILDINGS, DRIVEWAYS, SIDEWALKS, CANOPIES, AND OR PARKING AREAS DAMAGED, MODIFIED, AND OR DISTURBED BY DEMOLITION WORK AT NO COST TO THE OWNER.
14. ALL EXISTING EQUIPMENT THAT REMAINS SHALL BE PROTECTED DURING DEMOLITION AND OR CONSTRUCTION TO PREVENT DAMAGE. ANY DAMAGE TO REMAINING EXISTING EQUIPMENT SUSTAINED DURING DEMOLITION AND OR CONSTRUCTION SHALL BE EQUIVALENTLY REPLACED OR EQUIVALENTLY REPAIRED AT NO COST TO THE OWNER.
15. CONTRACTOR SHALL PROVIDE TRAFFIC HANDLING MEASURES TO PROTECT THE GENERAL PUBLIC AT ALL TIMES, AS NECESSARY AND AS REQUIRED BY AUTHORITIES HAVING JURISDICTION.
16. DO NOT INTERRUPT EXISTING UTILITIES, EXCEPT WHEN AUTHORIZED IN WRITING BY AUTHORITIES HAVING JURISDICTION. PROVIDE TEMPORARY SERVICES DURING INTERRUPTIONS TO EXISTING UTILITIES, AS ACCEPTABLE TO AUTHORITIES HAVING JURISDICTION.
17. WHEN UTILITY SERVICES ARE REQUIRED TO BE REMOVED, RELOCATED, OR ABANDONED, PROVIDE BYPASS CONNECTIONS TO MAINTAIN CONTINUITY OF SERVICE BEFORE PROCEEDING WITH DEMOLITION.
18. CONTRACTOR SHALL CONTACT ALL UTILITY COMPANIES INCLUDING BUT NOT LIMITED TO THE FOLLOWING: ELECTRIC, GAS, WATER, TELEPHONE, STORM SEWER, AND SANITARY SEWER FOR FIELD LOCATION OF ALL UNDERGROUND AND OVERHEAD UTILITY LINES. PRIOR TO COMMENCEMENT OF ANY DEMOLITION WORK, CONTRACTOR SHALL IDENTIFY ALL ELECTRICAL CIRCUITS SERVICING THE AREA INVOLVED WITH THIS DEMOLITION. THOSE CIRCUITS SHALL THEN BE LOCKED OUT AND TAGGED OUT IF THEY DO NOT SERVE ANY OF THE REMAINING BUILDING. THOSE CIRCUITS WHICH ARE IDENTIFIED TO SERVICE BOTH THE AREA TO BE DEMOLISHED AND THE REMAINING BUILDING SHALL BE SPLIT SO AS TO KILL ALL ELECTRICAL POWER TO THE AREA TO BE DEMOLISHED WHILE MAINTAINING POWER TO THE REMAINDER OF THE BUILDING.
19. CONTRACTOR SHALL RELOCATE UTILITIES AND EQUIPMENT AS REQUIRED TO ACCOMMODATE NEW HVAC, ELECTRICAL, PLUMBING, AND TECHNOLOGY REQUIREMENTS FOR NEW WORK.
20. PROTECT EXISTING SITE ELEMENTS AND EXISTING LANDSCAPING TO REMAIN. PROTECTION SHALL INCLUDE BUT NOT BE LIMITED TO EXISTING TREES AND OTHER EXISTING VEGETATION INDICATED TO REMAIN IN PLACE AGAINST UNNECESSARY CUTTING, BREAKING, OR SKINNING OF ROOTS, SKINNING OR BRUISING OF BARK, SMOTHERING OF TREES BY STOOPING CONSTRUCTION MATERIAL OR EXCAVATED MATERIAL WITHIN DRIP LINES.
21. CONTRACTOR SHALL REGRADE AND HYDROMULCH AREAS AFFECTED BY DEMOLITION.
22. OWNER HAS RIGHT OF REFUSAL OF ALL ITEMS REMOVED AS PART OF THE SCOPE OF WORK, WHETHER IDENTIFIED AS SALVAGE OR NOT.
23. NOTIFY THE BUILDING OWNER OF ANY MATERIALS, FIXTURES, ETC. TO BE REMOVED THAT ARE DESIRED SALVAGEABLE. TURN OVER ANY REQUESTED ITEMS TO THE BUILDING OWNER IN GOOD AND CLEAN CONDITION.
24. ALL FURNITURE WILL BE REMOVED OR RELOCATED BY THE OWNER AS NECESSARY PRIOR TO THE DEMOLITION WORK OF THIS PROJECT. CONTRACTOR SHALL COORDINATE WITH OWNER AS REQUIRED.
25. REMOVE EXISTING CONSTRUCTION TO THE EXTENT INDICATED ON THE DRAWINGS. SHOULD ANY DAMAGE OCCUR TO ANY EXISTING CONSTRUCTION TO REMAIN, THE CONTRACTOR SHALL REPAIR THE DAMAGE TO MATCH EXISTING AND OR ADJACENT CONSTRUCTION AT NO COST TO THE OWNER.
26. MAINTAIN ANY AND ALL EXISTING FIRE-RATED ASSEMBLIES THAT ARE TO REMAIN, AND THEIR ASSOCIATED FIRE RATINGS, INCLUDING BUT NOT LIMITED TO ALL ASSOCIATED EXISTING FIRE-RATED OPENINGS, ALL ASSOCIATED EXISTING FIRE-RATED PENETRATIONS, AND ALL ASSOCIATED EXISTING FIRE-RATED FIRESTOPPING CONDITIONS.
27. WHEN UNANTICIPATED MECHANICAL, ELECTRICAL, OR STRUCTURAL ELEMENTS THAT CONFLICT WITH THE INTENDED FUNCTION OR DESIGN ARE ENCOUNTERED, DETERMINE THE NATURE AND EXTENT OF THE CONFLICT AND NOTIFY THE ARCHITECT IMMEDIATELY FOR RESOLUTION.
28. REMOVE, PATCH, AND REPAIR ALL ABANDONED ROOF PENETRATIONS RESULTING FROM WORK.
29. SAW-CUT AND REMOVE EXISTING FLOOR FINISHES AND FLOOR SLABS AS REQUIRED TO INSTALL NEW FIXTURES, ITEMS, AND OR DEVICES FOR ALL SCOPE-OF-WORK PERTAINING TO NEW MECHANICAL WORK, NEW PLUMBING UTILITIES, NEW PLUMBING WORK, NEW ELECTRICAL WORK, AND NEW TECHNOLOGY WORK. SPLICE NEW REINFORCING BARS DOWELED INTO EXISTING CONCRETE AND PROVIDE NEW VAPOR RETARDER AND NEW CONTINUOUS WATERSTOPS AT JOINT BETWEEN NEW CONCRETE FLOOR SLAB AND EXISTING CONCRETE FLOOR SLAB. PATCH WITH NEW 3,500 PSI MINIMUM CONCRETE AND PREPARE FLOOR, INCLUDING NEW CONCRETE, TO RECEIVE NEW FLOOR FINISHES. COORDINATE WITH STRUCTURAL.
30. EXISTING WALLS (OR PORTIONS OF WALLS) TO BE REMOVED SHALL BE CUT FLUSH WHERE INTERSECTING WITH WALLS TO REMAIN. REMAINING WALLS TO BE PATCHED AND FINISHED SMOOTH.
31. NEW OPENING TO BE CUT IN EXISTING WALLS SHALL BE SAW-CUT AT LOCATIONS INDICATED TO THE HEIGHT AND WIDTH INDICATED. NEW LINTELS SHALL BE INSTALLED TO SUPPORT EXISTING WALL CONSTRUCTION ABOVE AS INDICATED ON THE DRAWINGS, OR IF NOT INDICATED, AS REQUIRED FOR NEW WALL CONSTRUCTION PER STRUCTURAL DRAWINGS. COORDINATE LOCATIONS OF ALL NEW OPENINGS IN EXISTING WALLS AND PARTITIONS WITH ARCHITECTURAL PLANS.
32. WHERE EXISTING WALL OPENINGS ARE TO BE NEWLY CLOSED-OFF, REMOVE ANY EXISTING OPENING FRAME AND PATCH AND REPAIR EXISTING WALL TO MATCH EXISTING ADJACENT MATERIALS AND FINISHES, UNLESS NOTED OTHERWISE.
33. WHERE EXISTING INTERIOR WALLS ARE REPLACED OR REMOVED, REMOVE MEPT SYSTEMS BACK TO PANEL, OR MECHANICAL ROOM, OR FARTHEST POSSIBLE POINT WITHOUT DISTURBING EXISTING CONSTRUCTION. REMOVE EXISTING MECHANICAL EQUIPMENT, RELOCATE POWER PER MEPT DRAWINGS.
34. REFER TO MEPT DRAWINGS FOR DEMOLITION OF MEPT SYSTEMS. IDENTIFY WORK REQUIRED BY THIS CONTRACTOR WHICH MAY AFFECT DEMOLITION AND OR REPAIRS OF ARCHITECTURAL ELEMENTS. COORDINATE WITH RELATED SUBCONTRACTORS THE EXTENT OF ALL DEMOLITION WORK.
35. PATCH FLOORS, WALLS CEILINGS WHICH REMAIN AT LOCATIONS WHERE PIPES, CONDUITS, ETC. ARE REMOVED AS REQUIRED TO MATCH EXISTING CONDITIONS OR TO RECEIVE NEW FINISHES.
36. WHERE EXISTING FINISH FLOOR IS REMOVED, PREPARE FLOOR SURFACE TO RECEIVE NEW FLOORING.
37. ALL DASHED LINES ARE DEMOLITION LINES U.N.O.



ARCHITECT PBK Architects, Inc.
 HOUSTON
 11 Greenway Plaza, 22nd Floor
 Houston, TX 77046
 713-965-0688 P
 713-961-4571 F
 TX Firm: BR 1638



ENGINEER
 LEAF ENGINEERS
 95
 1313-586-7225

MCISD - MISSION HS CULINARY ARTS

1802 CLEO DAWSON ST
 MISSION, TX 75712
 CONSTRUCTION DOCUMENTS

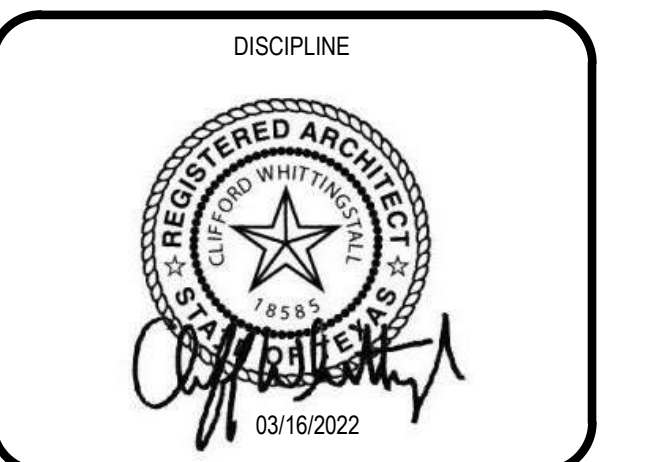
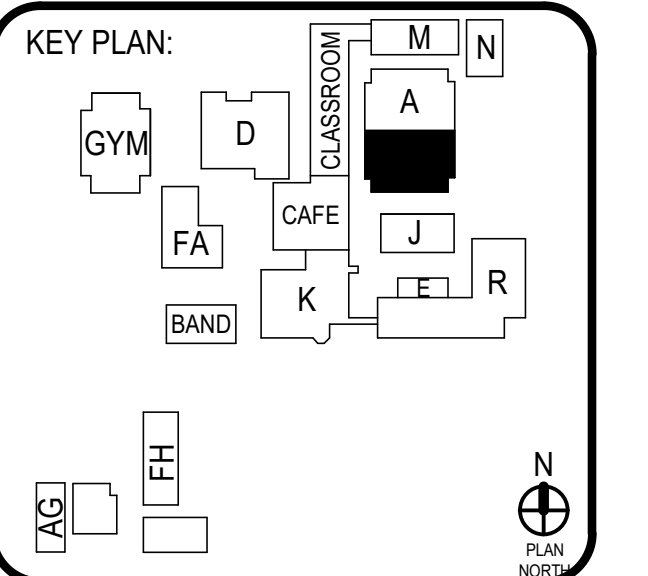

CLIENT		[Client Name]	
DATE	PROJECT NUMBER	[Project Number]	
YYYY/MM/DD	[Project Number]	[Project Number]	
No.	Description	Date	

CONSTRUCTION DOCUMENTS
 BUILDING NUMBER
EXISTING CONDITIONS OVERALL PLAN & DEMOLITION PLAN

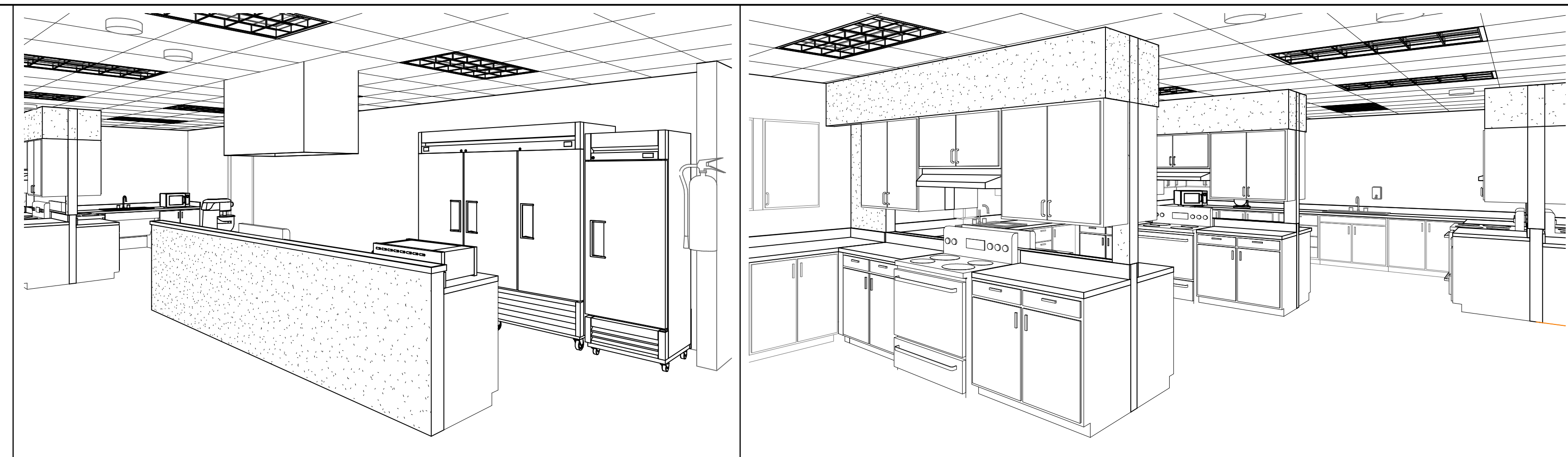

11 3D VIEW

12 3D VIEW

GENERAL ARCH PLAN NOTES

- DO NOT SCALE DRAWINGS. WRITTEN DIMENSIONS TAKE PRECEDENCE. CONTACT ARCH IF CLARIFICATION IS NECESSARY IN ORDER TO DETERMINE THE INTENT OF THE CONTRACT DOCUMENTS.
- DRAWINGS NOTED AS "N.T.S." OR "N.T.S." ARE NOT TO SCALE.
- ALL DIMENSIONS ARE TO STRUCTURAL COLUMN LINES OR THE SURFACE OF PARTITION ASSEMBLY U.N.O.
- FIELD VERIFY ALL DIMENSIONS AND EXISTING CONDITIONS BEFORE COMMENCING WORK. NOTIFY ARCH. OF ANY DISCREPANCIES PRIOR TO PROCEEDING WITH AFFECTED WORK.
- NOTES OR DIMENSIONS NOTED AS "TYPICAL" OR "TYP." OR "TYP" SHALL APPLY TO CONDITIONS THAT ARE THE SAME, OR SIMILAR.
- DIMENSIONS NOTED AS "FIELD VERIFY" OR "V.I.F." OR "V.I.P" SHALL BE MEASURED AND CONFIRMED AT THE PROJECT SITE BY THE CONTRACTOR AND REVIEWED WITH THE ARCH. BEFORE INCORPORATING INTO THE WORK.
- DIMENSIONS NOTED AS "CLEAR" OR "CLEAR INSIDE" REQUIRE SPECIFIC COORDINATION AMONG DISCIPLINES AND OR MANUFACTURERS.
- REFER TO PARTITION TYPES ON A&R SERIES SHEETS.
- ALL INTERIOR PARTITIONS THIS SHEET, EXCEPT FOR FURR-OUT PARTITIONS, SHALL BE PARTITION TYPE U.N.O.
- ALL INTERIOR FURR-OUT PARTITIONS THIS SHEET SHALL BE PARTITION TYPE U.N.O.
- ALIGN FINISHED FACE OF WALLS WHERE WALL PARTITIONS OF DIFFERING THICKNESS ABUT AND OR ADJOIN IN THE SAME PLANE.
- PROVIDE AND INSTALL CONT. REVEAL TRIM AT JOINT WHERE GYPSUM BOARD WALL PARTITIONS ABUT AND OR ADJOIN MASONRY WALL PARTITIONS IN THE SAME PLANE.
- ALL INTERIOR CMU OUTSIDE CORNERS SHALL HAVE BULLNOSE U.N.O.
- ALL DOORS SHALL BE SET 6 INCHES OFF THE ADJACENT PERPENDICULAR WALL ON THE HINGE SIDE OF THE DOOR U.N.O., NOTIFY ARCH. OF ANY DOOR-RELATED CONFLICTS, INCLUDING BUT NOT LIMITED TO CONFLICTS CONCERNING ACCESSIBILITY STANDARDS.
- ALL DOOR THRESHOLDS AT ALL EXTERIOR DOORS SHALL BE SET IN FULL BED OF SEALANT.
- COORD. ALL ROOF DRAIN LEADER LOCATIONS WITH FLOOR PLAN PRIOR TO FLOOR SLAB CONSTRUCTION.
- ALL FLOOR SLOPES TO FLOOR DRAINS SHALL NOT EXCEED 1:48.
- PROVIDE AND INSTALL SELF-LEVELING UNDERLAYMENT WHERE UNEVEN FLOOR SLAB EXISTS PRIOR TO INSTALLATION OF FLOOR FINISHES.
- COORD. HOUSEKEEPING PAD LOCATIONS AND DIMENSIONS WITH EQUIPMENT TO BE INSTALLED.
- ALL FLOOR FINISH CHANGES SHALL OCCUR AT THE CENTERLINE OF DOORS U.N.O.
- ALL FLOOR FINISH MATERIAL CHANGES SHALL HAVE REDUCER STRIPS.
- ALL REQUIRED ACCESSIBLE CLEARANCES FOR ALL ITEMS, INCLUDING BUT NOT LIMITED TO ALL COUNTER TOPS, ALL PLUMBING FIXTURES, ALL DRINKING FOUNTAINS, ALL ELECTRIC WATER COOLERS, ALL LAVATORIES, ALL URINALS, ALL TOILETS SHALL BE STRICTLY ENFORCED.
- APPLY BITUMINOUS COATING TO ALL CONCEALED STRUCTURAL STEEL MEMBERS AT ALL EXTERIOR CANOPY LOCATIONS.
- REFER TO OTHER DISCIPLINE DOCUMENTS FOR ADDITIONAL SCOPE OF WORK.



ARCHITECT HOUSTON
11 Greenway Plaza, 22nd Floor
Houston, TX 77046
713-965-0688 P
713-961-4571 F
TX Firm: BS 1608



1800 CLEO DAWSON ST
MISSION, TX 78572
CONSTRUCTION DOCUMENTS

MCISD - MISSION HS CULINARY ARTS

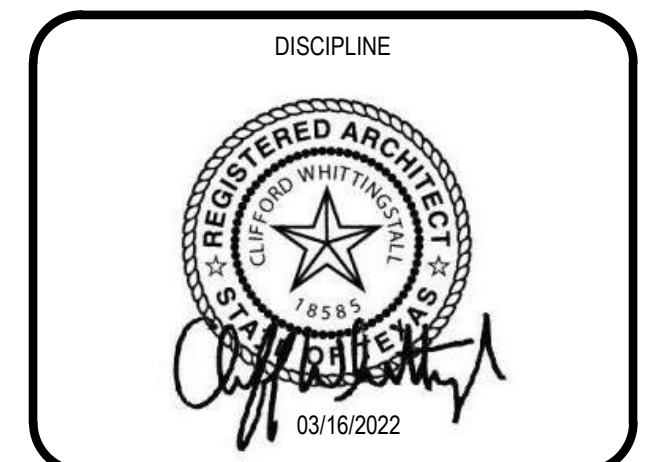
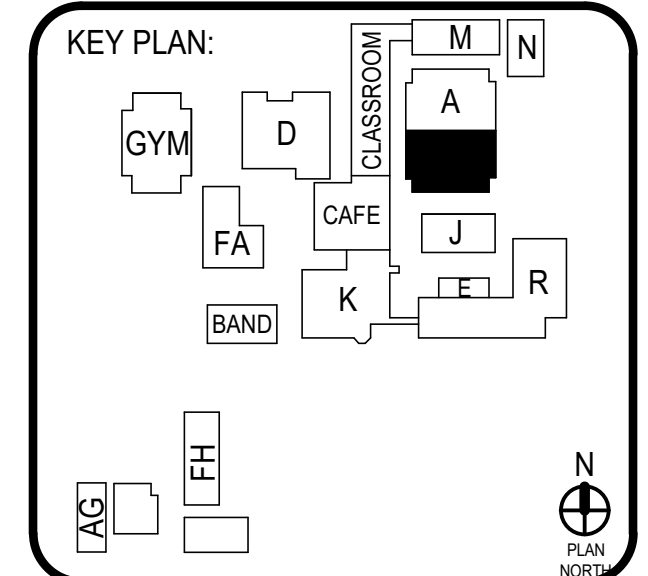

GENERAL CASEWORK NOTES

- FIELD VERIFY ALL CASEWORK-RELATED DIMENSIONS PRIOR TO FABRICATION AND INSTALLATION.
- VERIFY ALL COLUMN LOCATIONS PRIOR TO FABRICATION AND INSTALLATION.
- REFER TO MEPT DOCUMENTS FOR ALL DATA OUTLETS AND DEVICES, ELECTRICAL, OUTLETS AND DEVICES, AND PLUMBING FIXTURES. NOTIFY ARCHITECT OF ANY CONFLICTS PRIOR TO FABRICATION AND INSTALLATION.
- ALL CASEWORK BASE CABINETS SHALL BE 24 INCHES IN DEPTH, U.N.O.
- ALL CASEWORK UPPER WALL CABINETS SHALL BE 14 INCHES IN DEPTH, U.N.O.
- ALL COUNTER TOPS, VERTICAL SURFACES, NOSINGS, AND BACK SPLASHES SHALL BE PLASTIC LAMINATE FINISH U.N.O.
- PROVIDE AND INSTALL SIDE SPLASHES WHERE COUNTER TOP ENDS ABUT WALL SURFACES.
- PROVIDE AND INSTALL 1 INCH HIGH TOE SPACE WITH WALL BASE AT ALL CASEWORK, WALL BASE TO MATCH ROOM WALL BASE.
- PROVIDE AND INSTALL WALL ANCHORED VERTICAL SUPPORTS AT ALL KNEE SPACES GREATER THAN 48 INCHES WIDE.
- PROVIDE AND INSTALL GROMMETS WITH SLEEVES AT ALL KNEE SPACES.
- ALL CASEWORK UNITS 36 INCHES WIDE AND GREATER WITH SHELVING SHALL HAVE A CENTER FIXED SHELF.
- ALL SHELVING 36 INCHES WIDE AND GREATER SHALL BE 1 INCH THICK MINIMUM.
- ALL ADJUSTABLE SHELVING SHALL HAVE RECESSED STANDARDS HARDWARE.
- PROVIDE AND INSTALL FILLER PANELS WITH TOP RETURNS AT ALL SIDES, CORNERS, AND COLUMNS TO PREVENT THE CONTACT OF DOORS WITH ADJACENT SURFACES.
- PROVIDE AND INSTALL LOCKS AT ALL BASE CABINETS AND ALL UPPER WALL CABINETS.

FINISH LEGEND KEY

CODE	MATERIAL
PLAM	PLASTIC LAMINATE
PT	PAIN
SS	SOLID SURFACE

*VERIFY ALL FINISH SELECTIONS WITH OWNER AND ARCHITECT

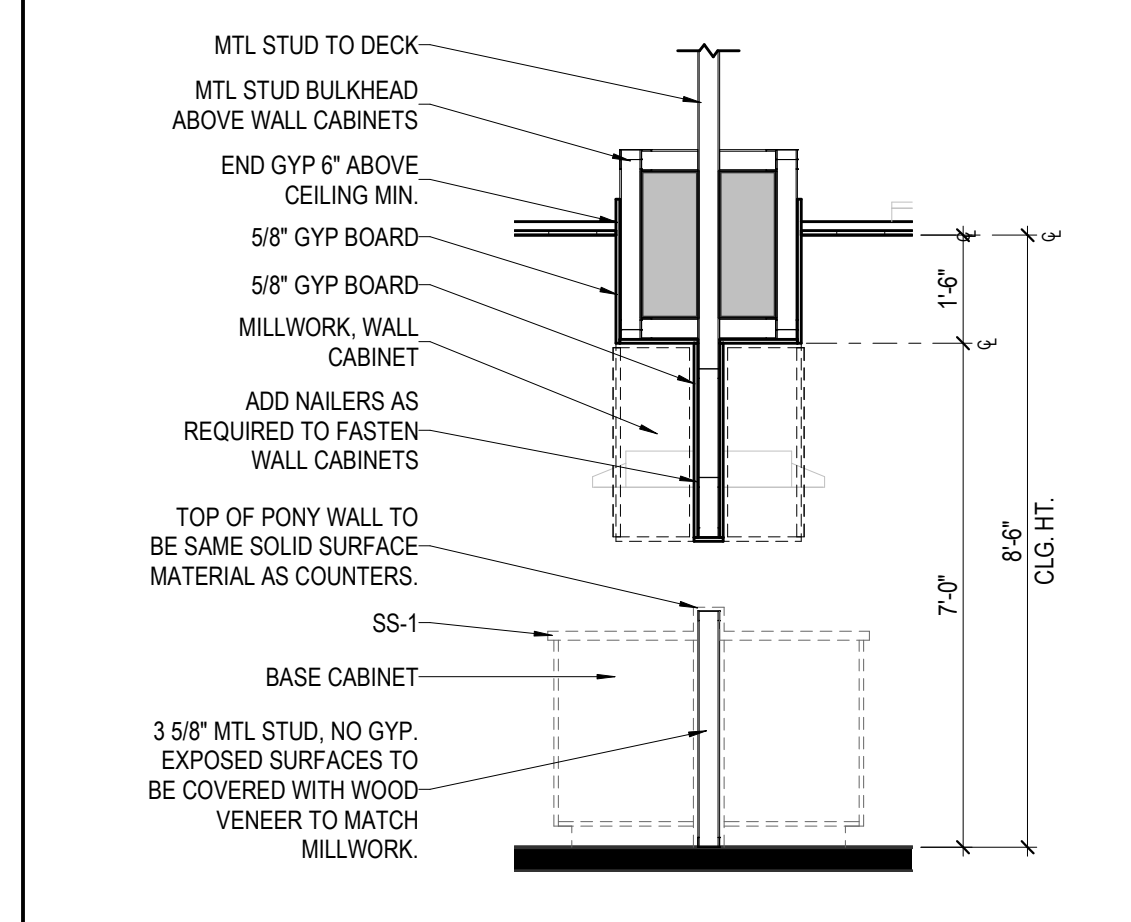

09 TYP. STUDENT STATION WALL SECTION
3/8" = 1'-0"

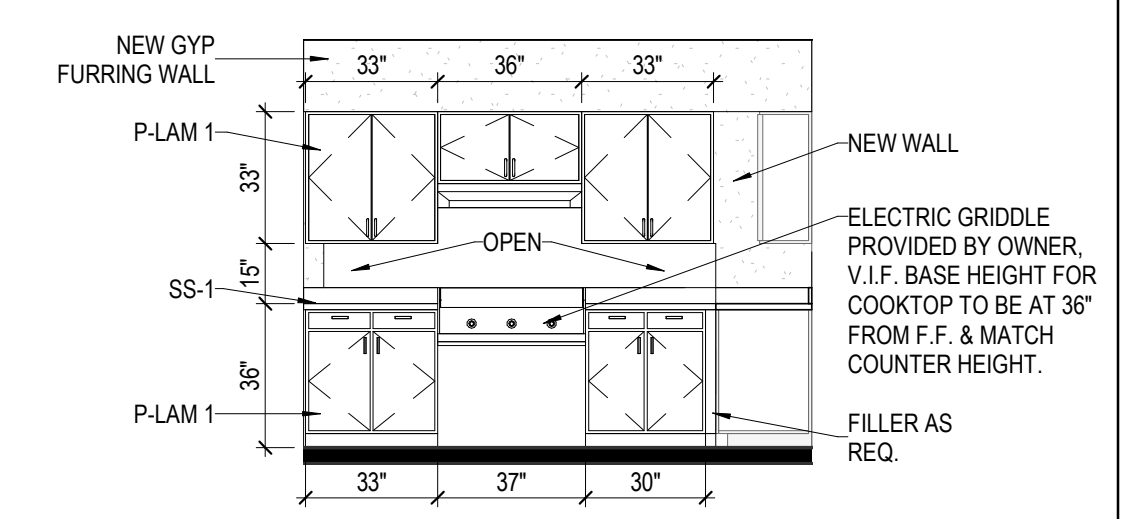

08 STUDENT STATION 04
1/4" = 1'-0"

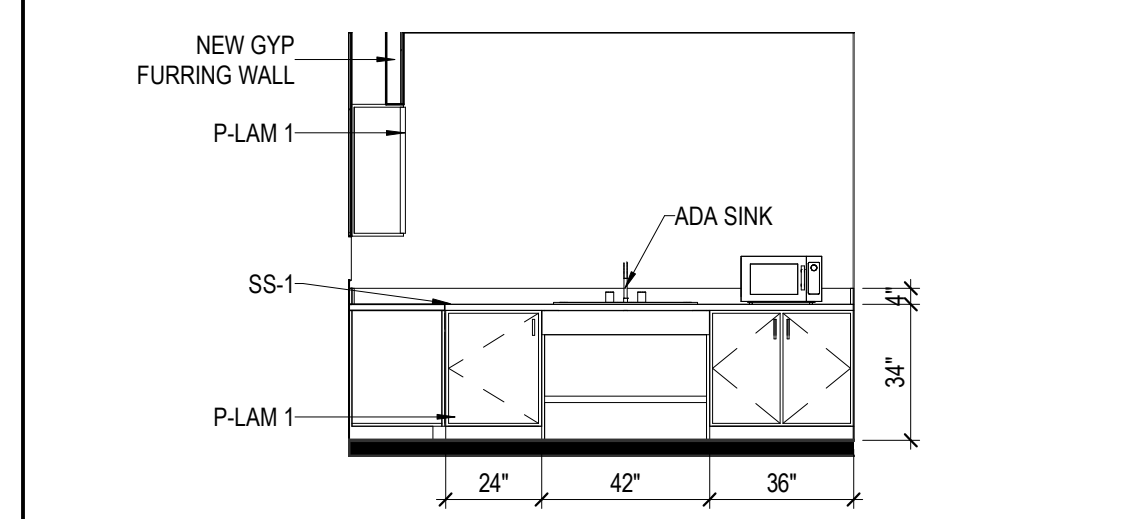

07 ADA STUDENT STATION
1/4" = 1'-0"

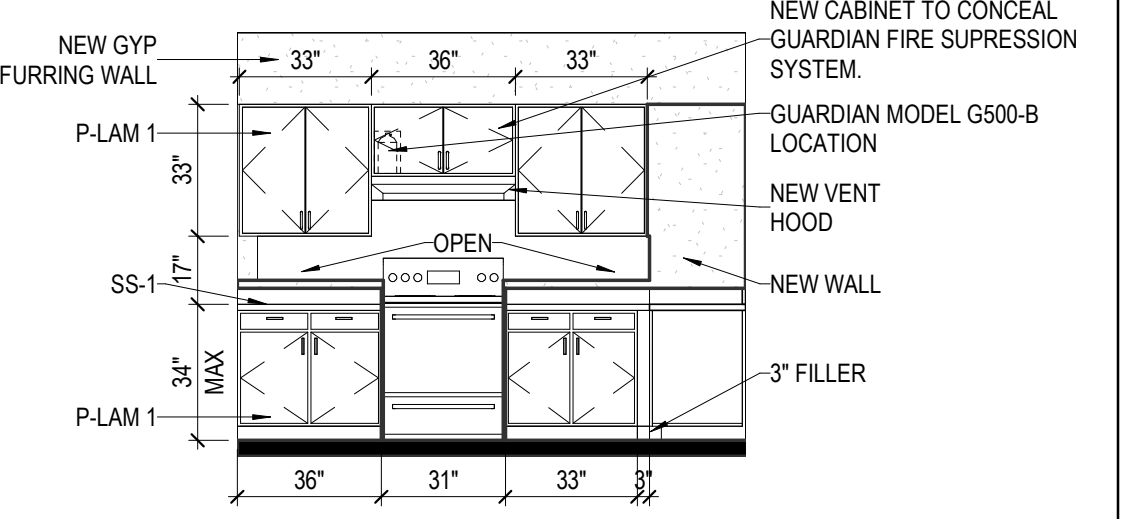

06 ADA STUDENT STATION
1/4" = 1'-0"

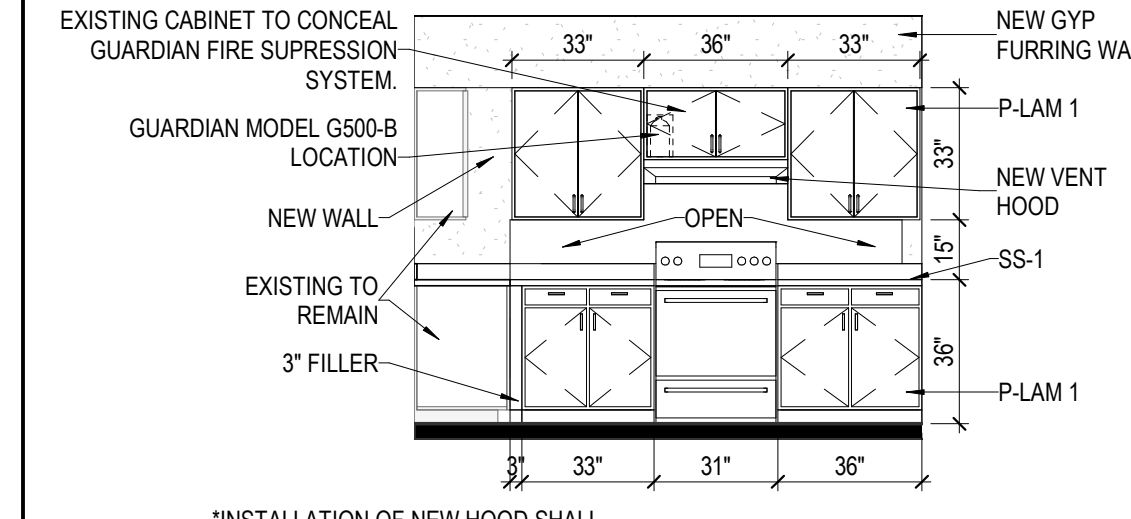

05 STUDENT STATION TYP.
1/4" = 1'-0"

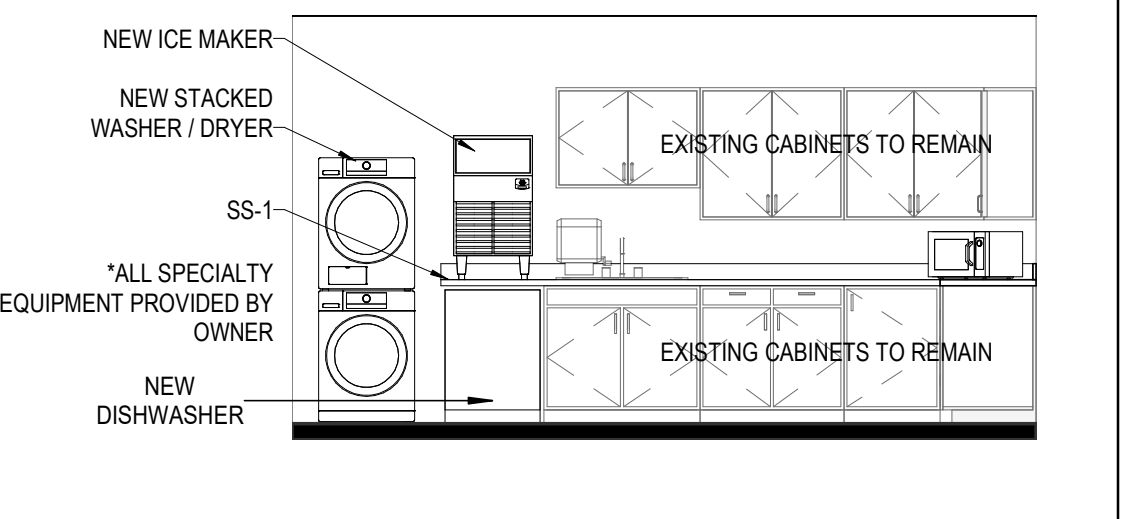

04 ELEVATION
1/4" = 1'-0"

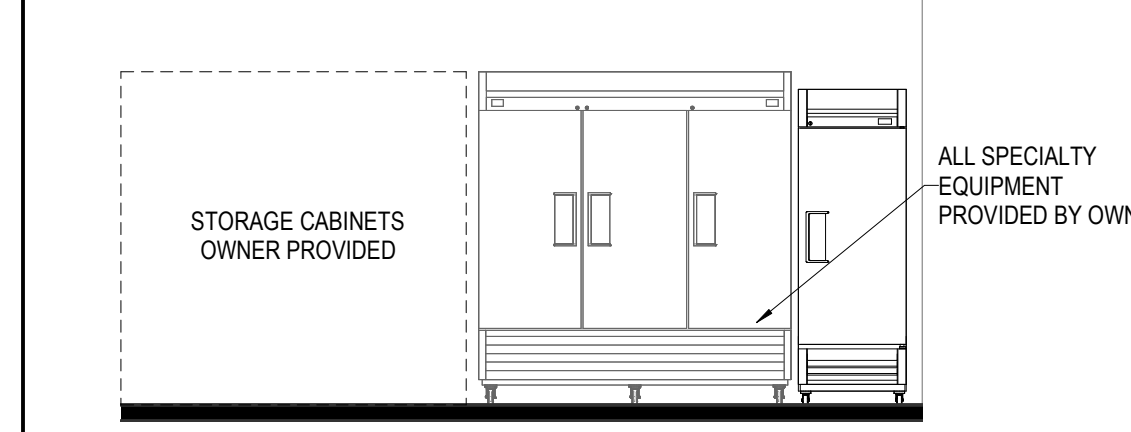

03 INSTRUCTOR'S STATION
1/4" = 1'-0"

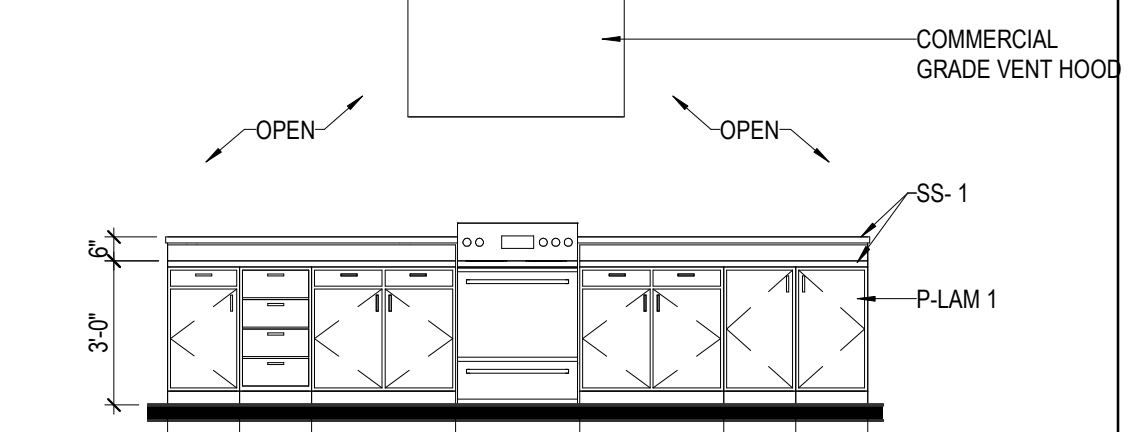

02 INSTRUCTOR'S STATION
1/4" = 1'-0"

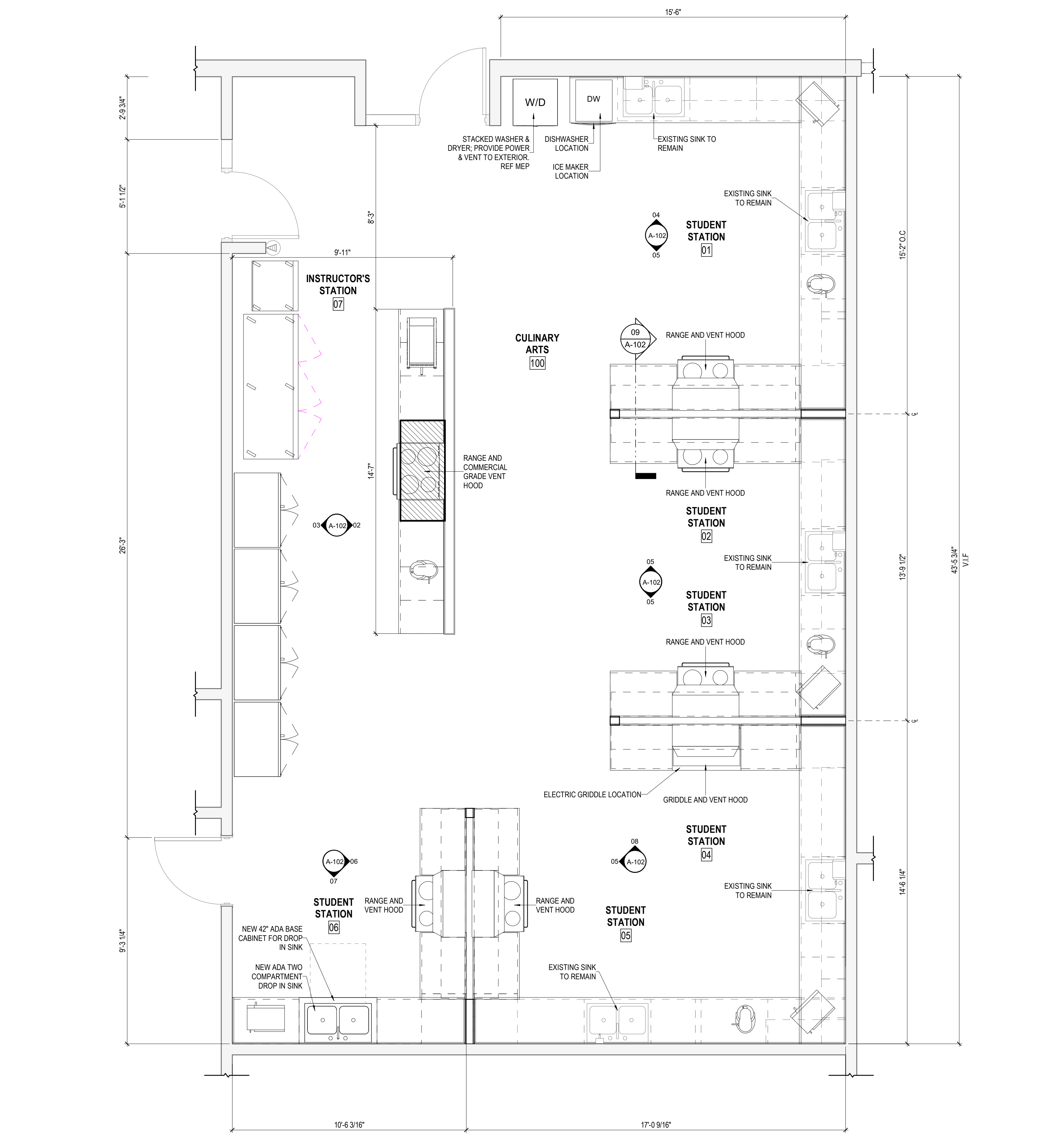

01 NEW FLOOR PLAN
3/8" = 1'-0"

CONSTRUCTION DOCUMENTS

NEW FLOOR PLAN

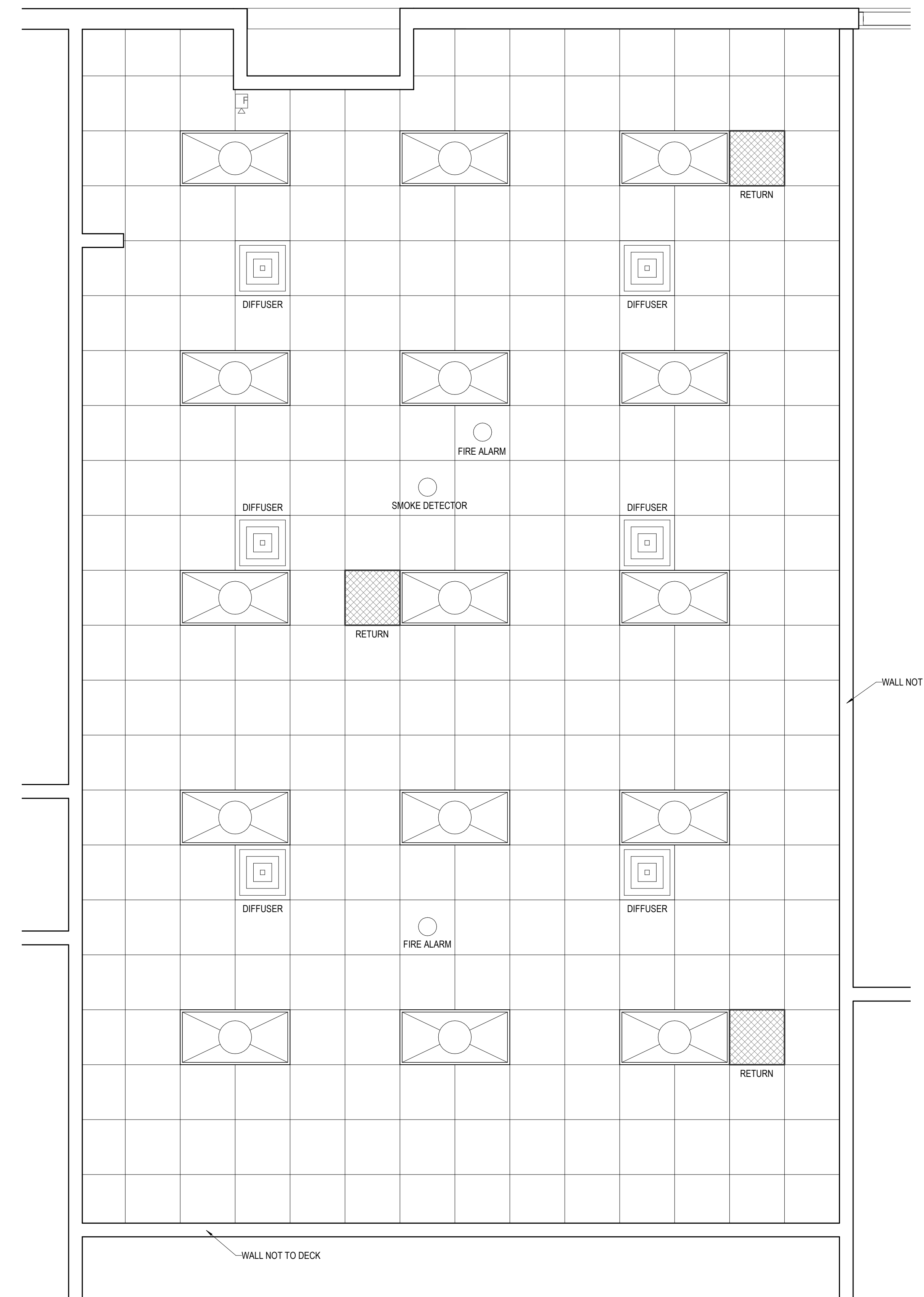
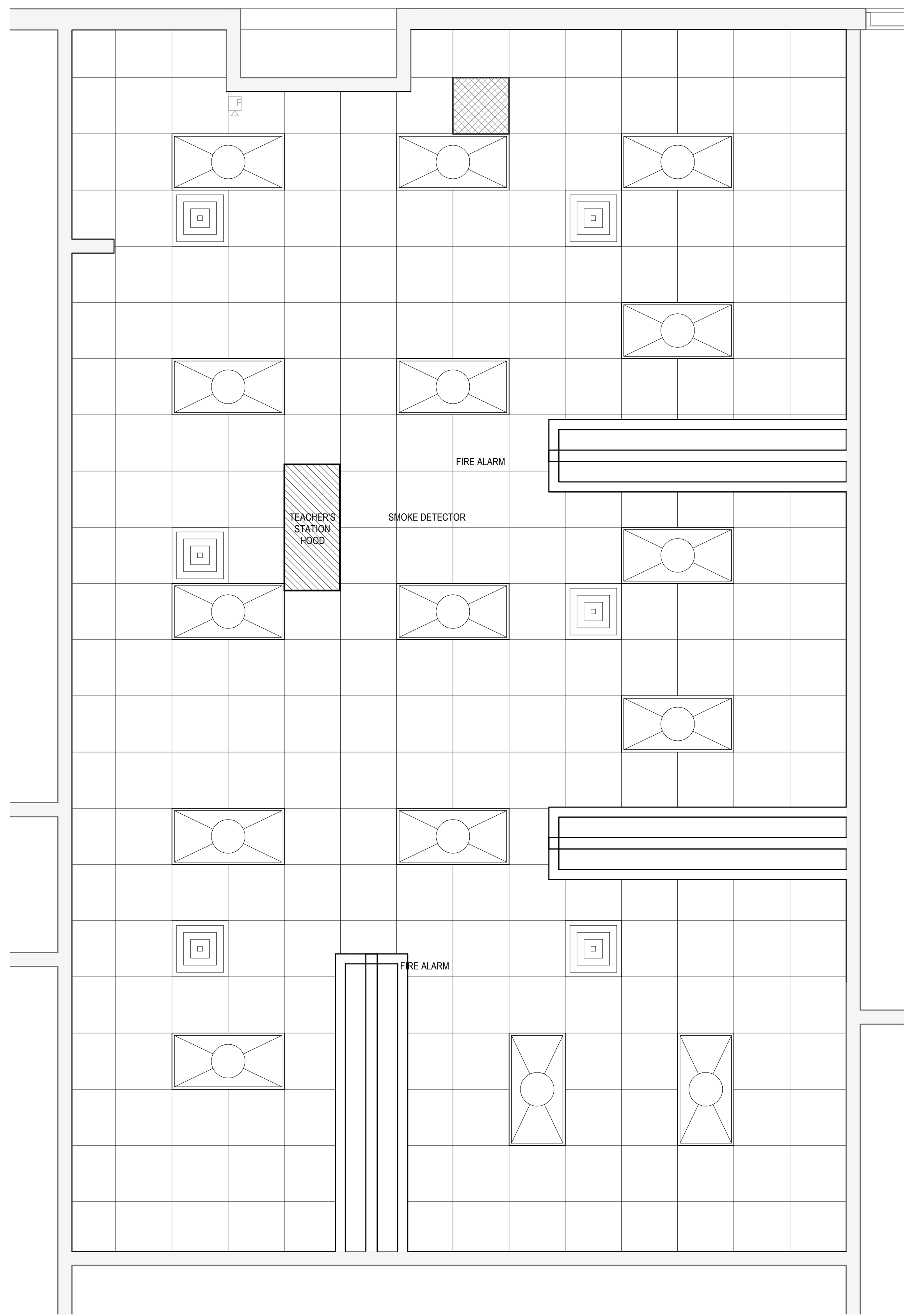

1 NEW RCP
3/8" = 1'-0"

2 RCP EXISTING CONDITIONS
3/8" = 1'-0"



ARCHITECT PBK Architects, Inc.
HOUSTON
11 Greenway Plaza, 22nd Floor
Houston, TX 77046
713-965-0688 P
713-961-4571 F
TX Firm: BS 1608



MISSION HS CULINARY ARTS
1800 CLEO DAWSON ST
MISSION, TX 78572
CONSTRUCTION DOCUMENTS

MISSION
CISD

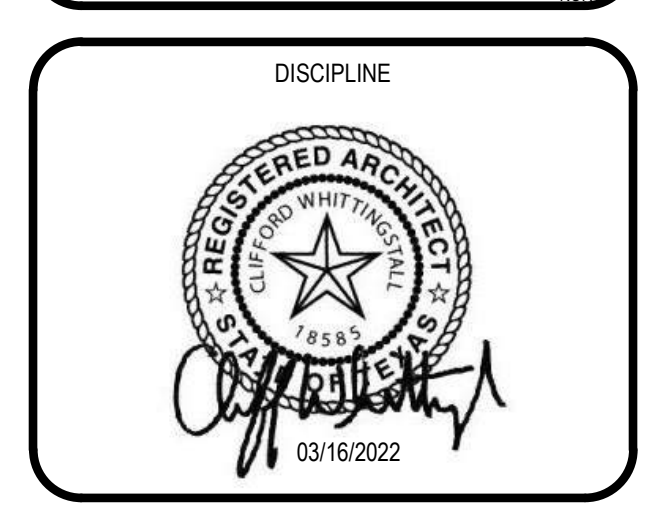
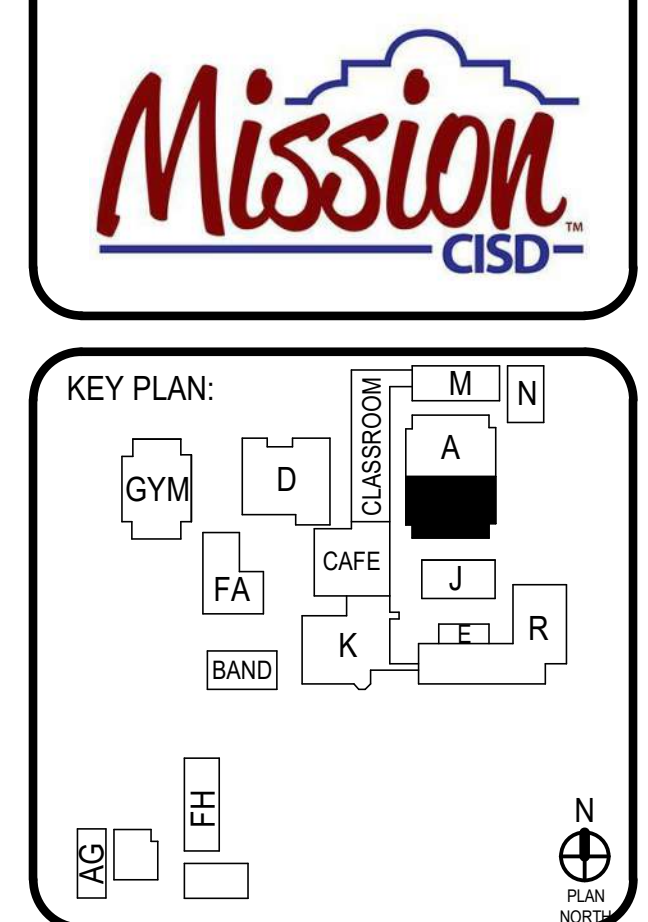

CLIENT		[Client Name]	
DATE	PROJECT NUMBER	[Project Number]	
YYYY/MM/DD	[Project Number]	[Project Number]	
DRAWING HISTORY			
No.	Description	Date	

CONSTRUCTION DOCUMENTS
BUILDING NUMBER

RCP
A-103

SYMBOL	DESCRIPTION	SYMBOL	DESCRIPTION
	BACKDRAFT DAMPER		NEW DUCTWORK
	BAROMETRIC DAMPER		EXISTING DUCTWORK TO REMAIN
	FLEXIBLE CONNECTION		EXISTING DUCTWORK TO BE REMOVED
	MECHANICAL EQUIPMENT		CONNECTION TO EXISTING
	SUPPLY AIR TERMINAL		
	RETURN AIR TERMINAL		
	EXHAUST AIR TERMINAL		

ACC	AIR COOLED CHILLER	DFA	DOWN FROM ABOVE	GBD	GRAVITY BACKDRAFT DAMPER	RA	RETURN AIR
ACCU	AIR COOLED CONDENSING UNIT	DR	RETURN DUCT SMOKE DETECTOR	GC	GENERAL CONTRACTOR	RF	RELIEF FAN
ACU	AIR CONDITIONING UNIT	DS	SUPPLY DUCT SMOKE DETECTOR	GV	GRAVITY VENTILATOR	SD	SMOKE DAMPER
AFF	ABOVE FINISHED FLOOR	DY	DRYER	HOA	HAND OFF AUTOMATIC SWITCH	SEF	SMOKE EXHAUST FAN
AFR	ABOVE FINISHED ROOF	E.C.	ELECTRICAL CONTRACTOR	HP	HORSEPOWER	SPEC	SPECIFICATION
AHAP	AS HIGH AS POSSIBLE	EDH	ELECTRIC DUCT HEATER	KEF	KITCHEN EXHAUST FAN	TEF	TOILET EXHAUST FAN
AHU	AIR HANDLING UNIT	EF	EXHAUST FAN	KSU	KITCHEN SUPPLY UNIT	UL	UNDERWRITERS LABORATORIES
AP	ACCESS PANEL	EX	EXISTING	KW	KILOWATTS	U.N.O.	UNLESS NOTED OTHERWISE
AS	AIR SEPARATOR	FIXT	FIXTURE	MCC	MOTOR CONTROL CENTER	VAV	VARIABLE AIR VOLUME
ASHRAE	AMERICAN SOCIETY OF HEATING, REFRIGERATING AND AIR-CONDITIONING ENGINEERS	FD	FIRE DAMPER	MD	MANUAL BALANCING DAMPER	WP	WEATHERPROOF
BFF	BELOW FINISHED FLOOR	FPB	FAN POWERED TERMINAL BOX	MTD	MOUNTED		
BFG	BELOW FINISHED GRADE	FSD	COMBINATION FIRE / SMOKE DAMPER	NIC	NOT IN CONTRACT		
				OFCI	OWNER FURNISHED / OWNER INSTALLED		
				OA	OUTSIDE AIR		

- GENERAL NOTES - MECHANICAL PLAN**
- THE DRAWINGS ARE DIAGRAMMATIC AND INDICATE THE GENERAL LOCATION OF EQUIPMENT, DUCTS, AND GRILLES ETC. IT IS THE INTENT OF THESE DRAWINGS AND SPECIFICATIONS THAT COMPLETE MECHANICAL SYSTEMS BE FURNISHED, INSTALLED, TESTED AND READY FOR OPERATION WHETHER OR NOT EVERY ITEM OF EQUIPMENT, ACCESSORY, DEVICE, ETC. IS SHOWN. REFERENCE SHALL BE MADE TO THE FULL DRAWING PACKAGE INCLUDING ARCHITECTURAL, STRUCTURAL, ELECTRICAL, AND PLUMBING DRAWINGS FOR COORDINATION AND POTENTIAL CONFLICTS. THE MECHANICAL SUBCONTRACTOR SHALL, WITHOUT EXTRA CHARGE, MAKE REASONABLE MODIFICATIONS IN THE LAYOUT AS NEEDED TO PREVENT CONFLICTS WITH OTHER TRADES, OR FOR PROPER EXECUTION OF THE WORK. FIELD VERIFY ALL DIMENSIONS BEFORE FABRICATING DUCTWORK.
 - DUCT DIMENSIONS INDICATED ON DRAWINGS ARE CLEAR INSIDE AIR STREAM DIMENSIONS.
 - FLEX DUCT SHALL NOT EXCEED 5 FEET, NO EXCEPTIONS.
 - DO NOT SCALE DRAWINGS. VERIFY ALL DIMENSIONS AND CLEARANCES FROM ARCHITECTURAL, STRUCTURAL, SUBMITTALS, AND OTHER APPROPRIATE DRAWINGS OR PHYSICALLY AT SITE. REVIEW ALL DRAWINGS, INCLUDING THOSE OF OTHER TRADES.
 - COORDINATE ALL WORK WITH ALL OTHER TRADES PRIOR TO INSTALLATION TO PROVIDE CLEARANCES REQUIRED FOR OPERATION, MAINTENANCE, CODE COMPLIANCE, AND TO VERIFY NON-INTERFERENCE WITH OTHER WORK. DO NOT FABRICATE PRIOR TO VERIFICATION OF NECESSARY CLEARANCES FOR ALL TRADES. BRING ANY INTERFERENCES OR CONFLICTS TO THE ATTENTION OF THE ARCHITECT/ENGINEER BEFORE PROCEEDING WITH FABRICATION OR EQUIPMENT ORDERS.
 - ANY CHANGES REQUIRED TO ELIMINATE CONFLICTS OR THAT RESULT FROM A FAILURE TO COORDINATE SHALL BE MADE BY THE CONTRACTOR WITHOUT ADDITIONAL COST OR EXPENSE TO OTHERS.
 - REFER TO ARCHITECTURAL REFLECTED CEILING PLAN, ELECTRICAL, TECHNOLOGY AUDIOVISUAL, AND OTHER MECHANICAL PLANS FOR EXACT LOCATIONS OF ALL CEILING MOUNTED DEVICES, OTHER THAN SPRINKLERS.
 - EACH CONTRACTOR IS RESPONSIBLE FOR DAMAGE CAUSED BY THEIR ACTIONS TO WALLS, FLOORS, CEILINGS, AND ROOFS. THE CONTRACTOR WHOSE WORK CAUSES DAMAGE IS RESPONSIBLE FOR PATCHING TO MATCH ORIGINAL CONSTRUCTION, FIRE RATING, AND FINISH.
 - CAULK ALL PIPE AND DUCT PENETRATIONS OF FULL HEIGHT NON-FIRE RATED WALL, PARTITION, FLOOR, AND ROOF ASSEMBLIES. THIS IS ESSENTIAL TO PREVENT NOISE TRANSMISSION FROM ONE ROOM TO ANOTHER AND TO PROVIDE THE DESIRED NC LEVELS WITHIN ROOMS.
 - PROVIDE VOLUME DAMPERS AT BRANCH CONNECTION SERVING EACH AIR DEVICE. INACCESSIBLE DAMPERS, OR DAMPERS CONCEALED BY HARD CEILINGS SHALL BE PROVIDED WITH REMOTE DAMPER OPERATOR EQUIVALENT TO ROTOTWISTS "RT" SERIES.

- KEYED NOTES - MECHANICAL PLAN**
- AIR DEVICE SHALL BE REMOVED AND RELOCATED TO ACCOMMODATE NEW ARCHITECTURAL RCP. REFER TO NEW WORK PLAN FOR LOCATION.
 - 4" ROUND DRYER EXHAUST, ROUTE ABOVE TO ROOF. REFER TO DETAILS. CONTRACTOR SHALL VERIFY THAT THE TOTAL EQUIVALENT LENGTH OF DUCTWORK DOES NOT EXCEED THE MANUFACTURER'S RECOMMENDATIONS. IF THE TOTAL EQUIVALENT LENGTH EXCEEDS THE MANUFACTURER'S RECOMMENDATIONS, THE CONTRACTOR SHALL PROVIDE A BOOSTER FAN AND COORDINATE ELECTRICAL REQUIREMENTS WITH ELECTRICAL CONTRACTOR.
 - 6" ROUND EXHAUST DUCT FOR KITCHEN HOOD. DUCTWORK SHALL BE CONSTRUCTED ACCORDING TO 2015 INTERNATIONAL MECHANICAL CODE SECTION 505. ROUTE TO ABOVE ROOF AND GOOSENECK. PROVIDE AND INSTALL BACKDRAFT DAMPER IF HOOD IS NOT PROVIDED WITH BACKDRAFT DAMPER. CONTRACTOR SHALL PROVIDE NECESSARY OFFSETS TO AVOID EXISTING OBSTRUCTIONS. CONTRACTOR SHALL VERIFY THE SIZE OF DUCTWORK WITH THE MANUFACTURER.
 - NEW 2-WAY AIR DEVICE TITUS MODEL TDC OR EQUAL. NEW AIR DEVICE SHALL MATCH EXISTING CONSTRUCTION AND INLET SIZE.
 - EXISTING AIR DEVICE SHALL BE REMOVED AND REPLACED WITH NEW.
 - NEW LOCATION OF SUPPLY AIR DEVICE. EXTEND FLEX DUCT AS REQUIRED. FLEX DUCT SHALL NOT EXCEED 5 FEET. IF FLEX DUCT WILL EXCEED 5 FEET, CONTRACTOR SHALL EXTEND HARD DUCT SO THAT FLEX FALLS BELOW THE MAXIMUM LENGTH.
 - NEW LOCATION OF RETURN AIR DEVICE. PROVIDE AND INSTALL RETURN AIR CANOPY PRICE MODEL RAC FOR NOISE CONTROL.

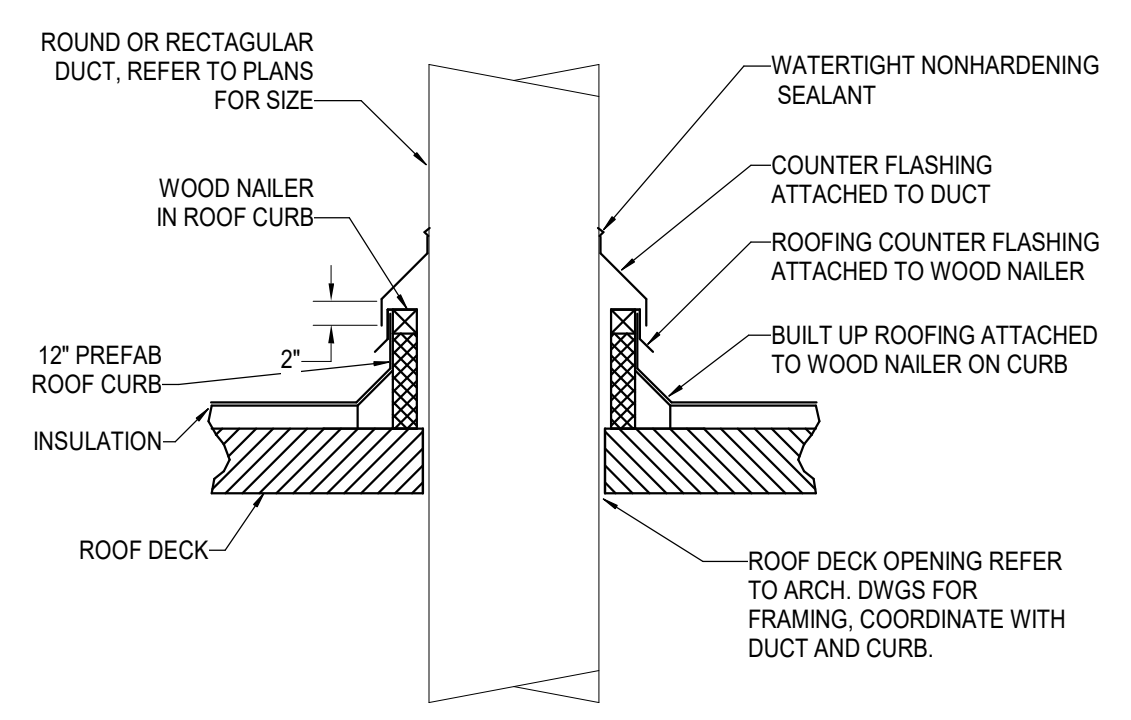

NOTE:
FLASHING SHALL BE COMPATIBLE WITH EXISTING ROOFING. ALL MATERIALS USED SHALL BE AS RECOMMENDED BY EXISTING ROOFING SYSTEM MANUFACTURER.

5 DUCT PENETRATION THROUGH ROOF
SCALE: NOT TO SCALE

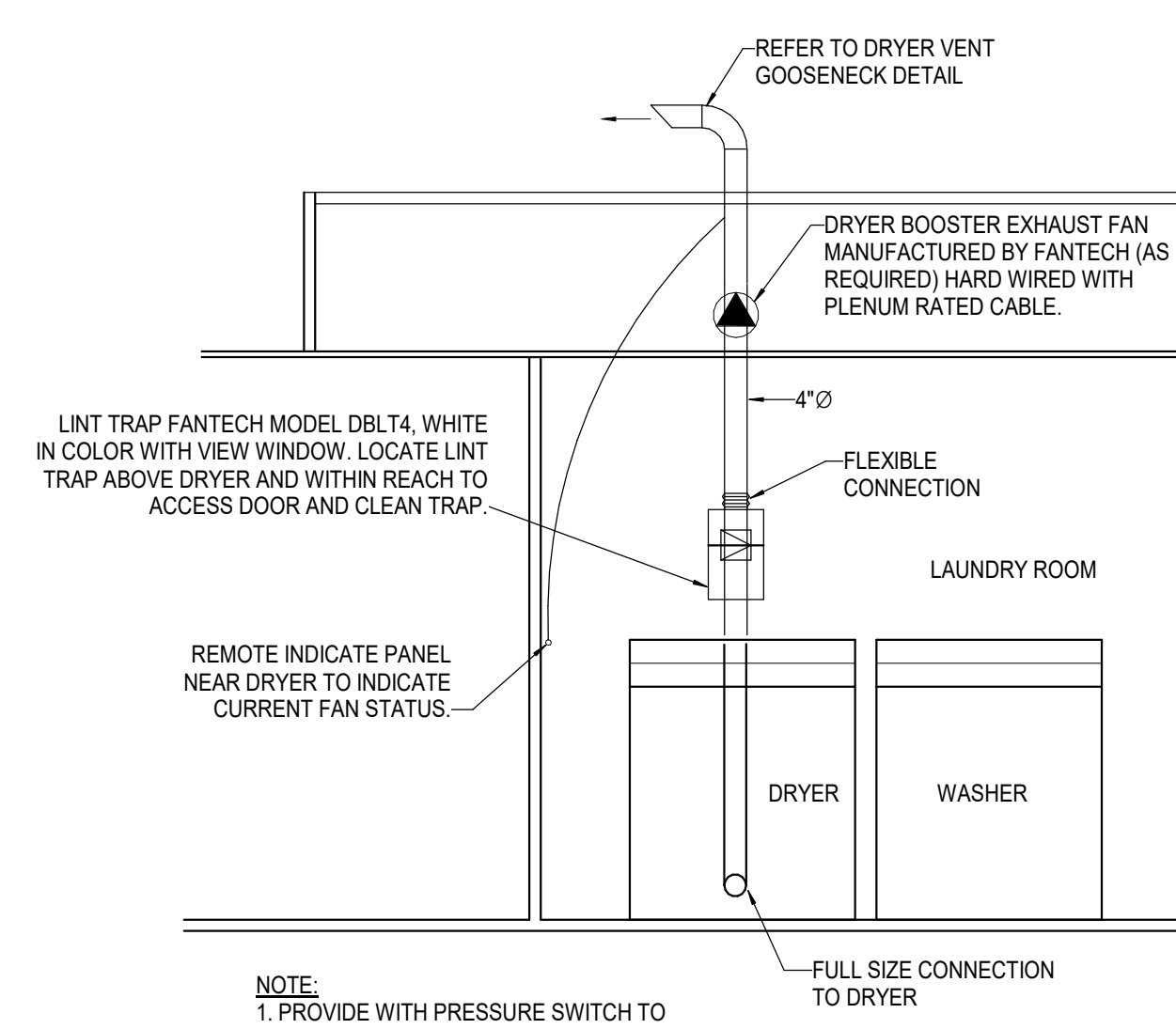

4 DRYER VENT DETAIL
SCALE: NOT TO SCALE

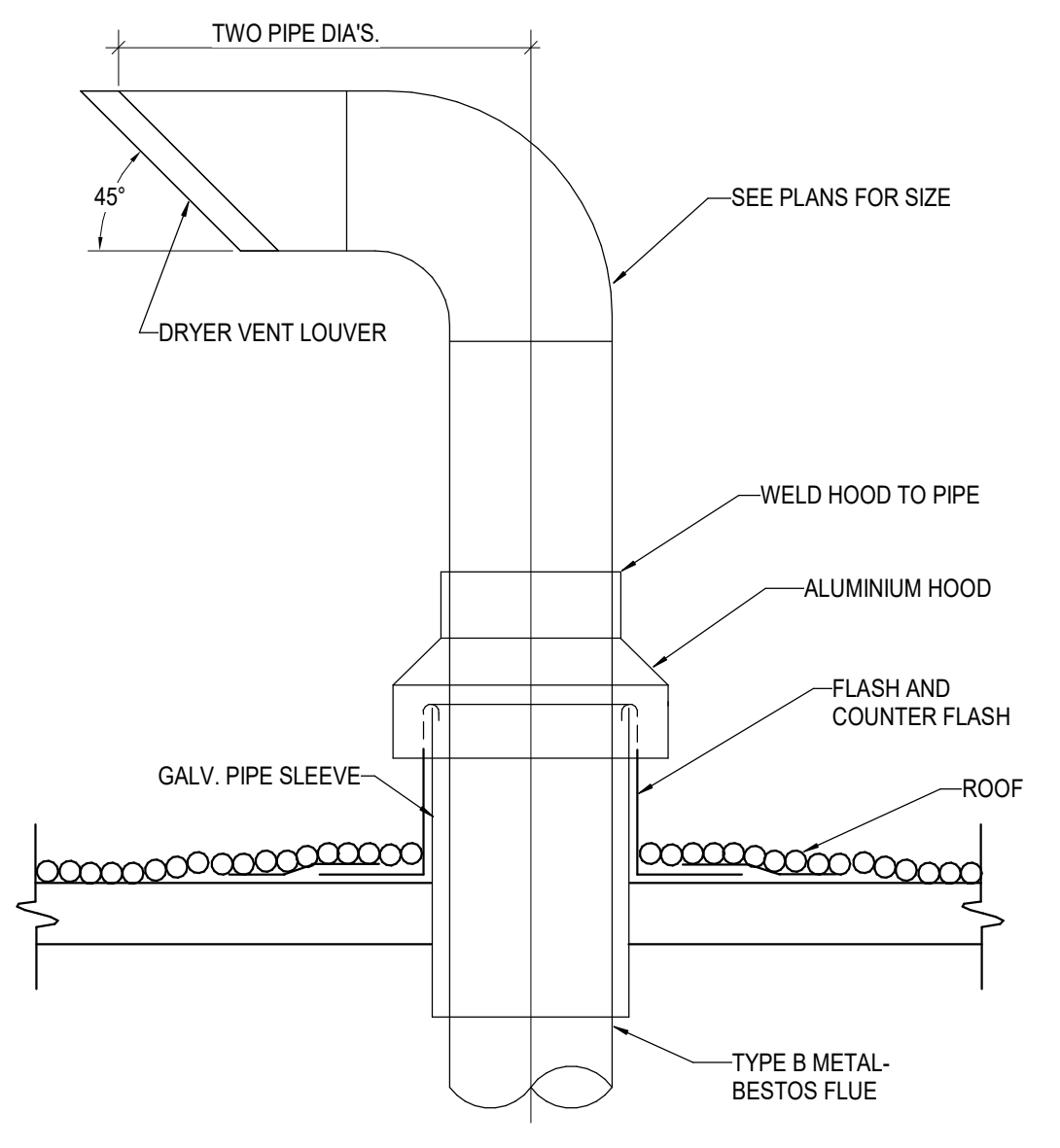

3 DRYER VENT TO GOOSENECK DETAIL
SCALE: NOT TO SCALE

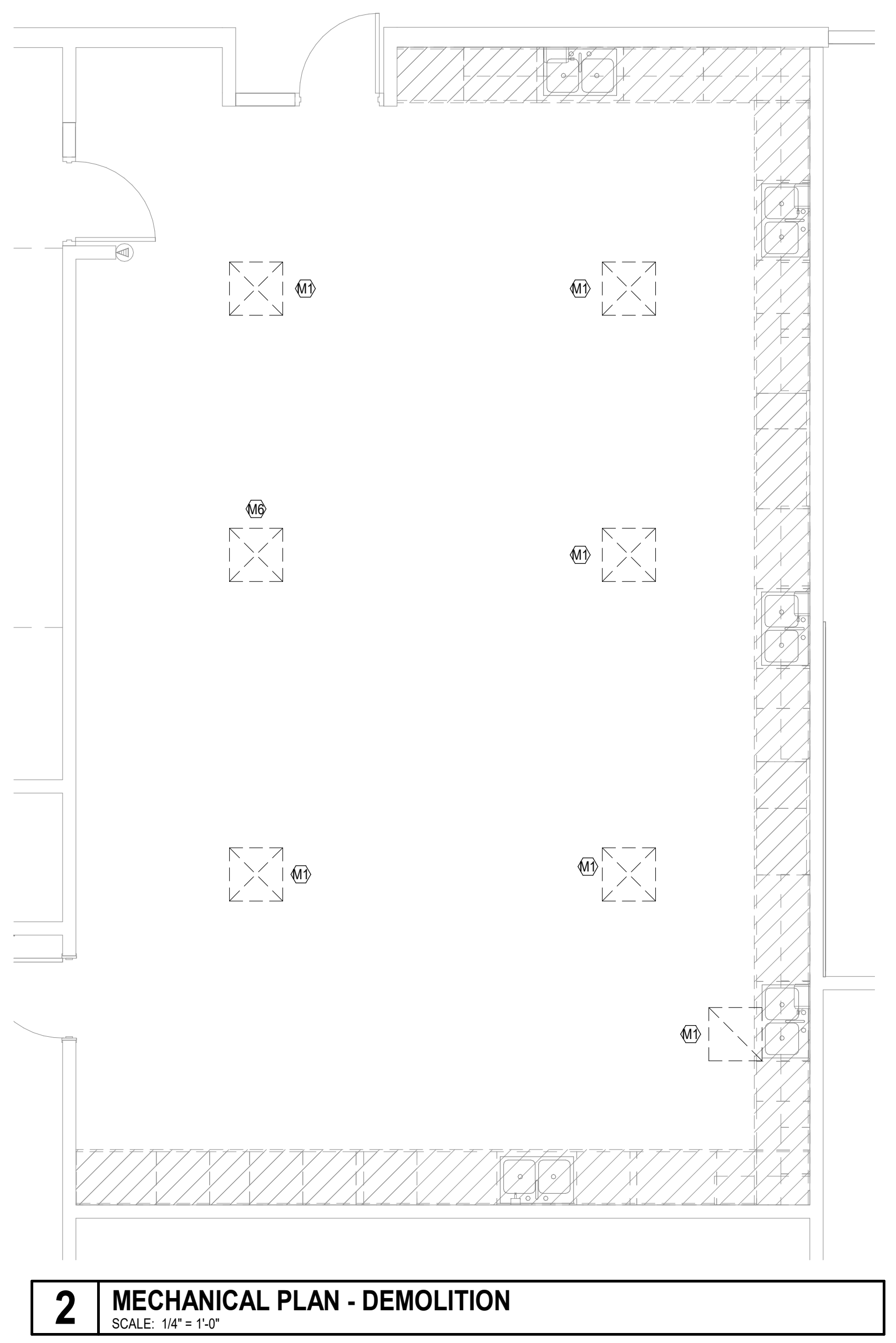

2 MECHANICAL PLAN - DEMOLITION
SCALE: 1/4" = 1'-0"

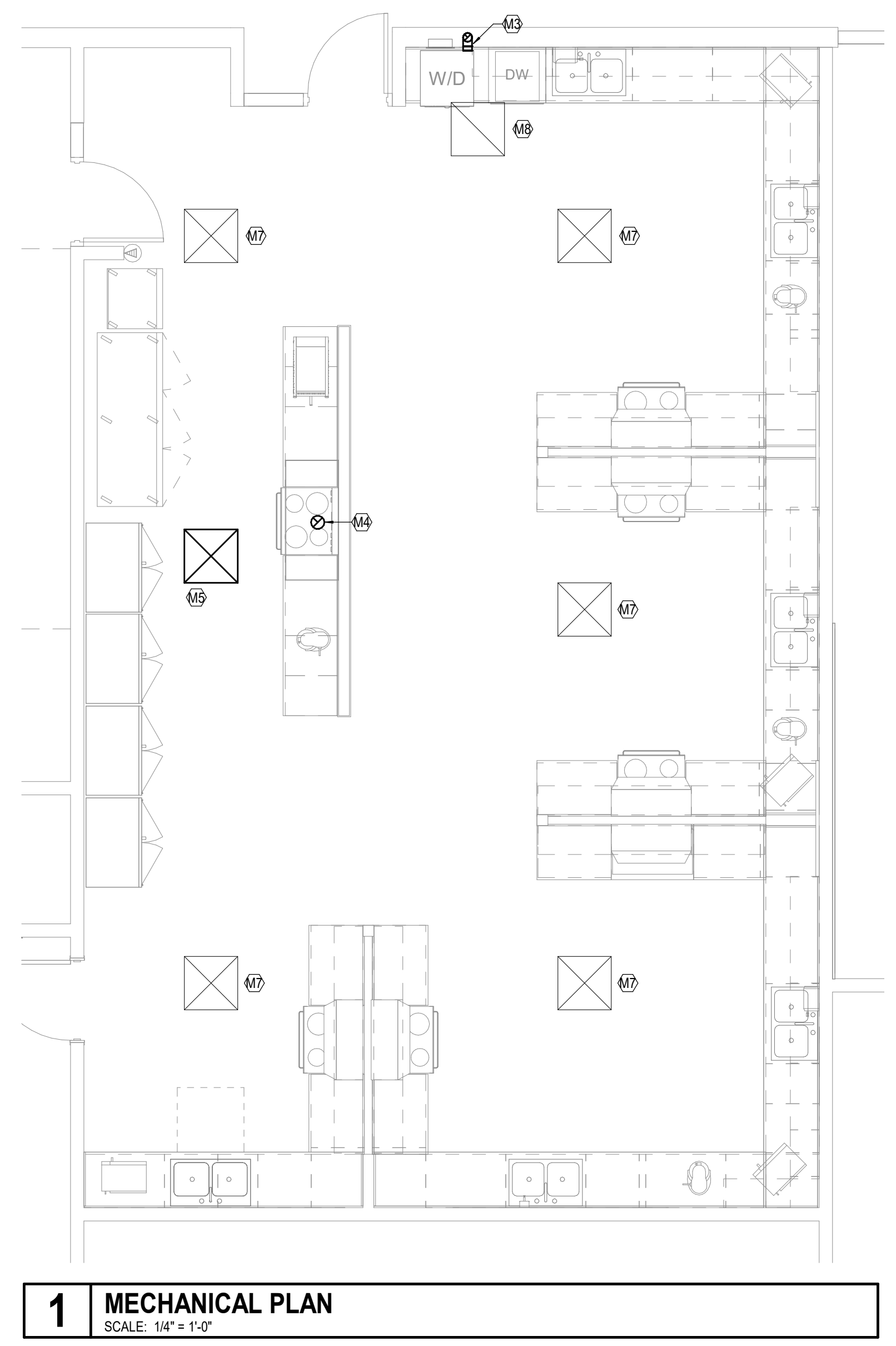

1 MECHANICAL PLAN
SCALE: 1/4" = 1'-0"

ARCHITECT: PBK Architects, Inc.
SAN ANTONIO
601 N.W. Loop 410, Suite 400
San Antonio, TX 78216
210-829-0123 P
210-829-0578 F
TX Firm: BR-1688

98
118502
1.713.686.7200

MCSID - MISSION HS CULINARY ARTS

1800 CLEO DAWSON ST
MISSION, TX 78572

ISSUE FOR CONSTRUCTION

KEY PLAN:

DISCIPLINE: MECHANICAL
TAE S. KWANG
LICENSED PROFESSIONAL ENGINEER
LEAF ENGINEERS
F-18672

CLIENT		PROJECT NUMBER	
MCSID		P2132600AR	
DATE	2022/03/16		

DRAWING HISTORY

No.	Description	Date

ISSUE FOR CONSTRUCTION

BUILDING NUMBER

MECHANICAL PLAN

M2.01

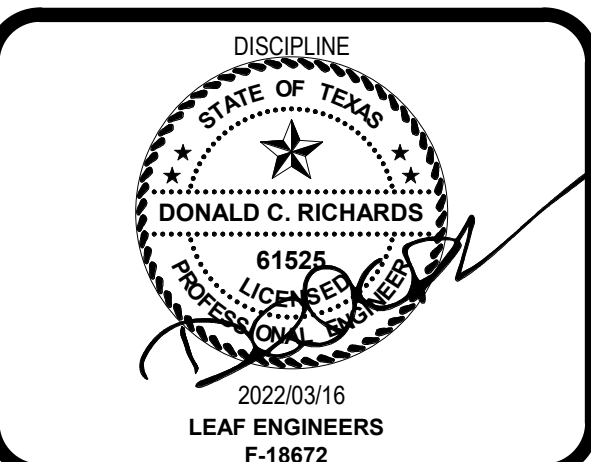
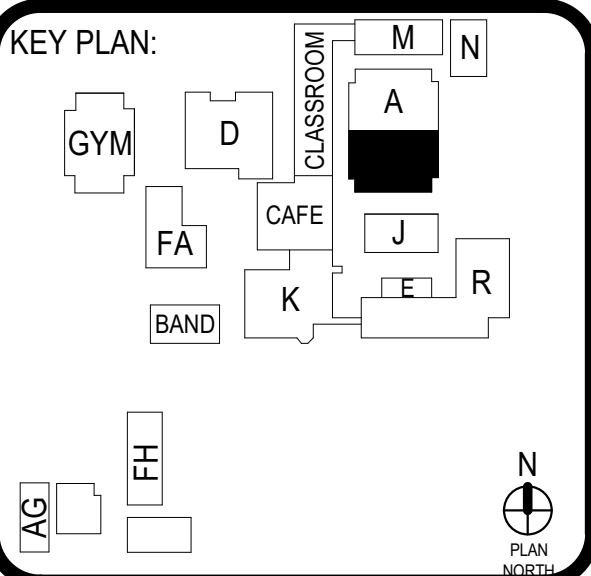

CLIENT MCSID		
DATE 2022/03/16	PROJECT NUMBER P2132600AR	
DRAWING HISTORY		
No.	Description	Date

ISSUE FOR CONSTRUCTION

BUILDING NUMBER

ELECTRICAL SYMBOLS AND ABBREVIATIONS

A	AMPERE	FAA	FIRE ALARM ANNUNCIATOR PANEL	NO	NUMBER OR NORMALLY OPEN
AC	ABOVE COUNTER	FCU	FAN COIL UNIT	NTS	NOT TO SCALE
AFF	ABOVE FINISHED FLOOR	GEN	GENERATOR	PNL	PANELBOARD
AFG	ABOVE FINISHED GRADE	GFI	GROUND FAULT INTERRUPTER	RECP	RECEPTACLE
AHU	AIR HANDLING UNIT	GND	GROUND	REQD	REQUIRED
ATS	AUTOMATIC TRANSFER SWITCH	GRS	GALVANIZED RIGID STEEL	RTU	ROOFTOP UNIT
C	CONDUIT	HID	HIGH INTENSITY DISCHARGE	TEL	TELEPHONE
CB	CIRCUIT BREAKER	HP	HORSEPOWER OR HEAT PUMP	TR	TAMPER RESISTANT
CCTV	CLOSED CIRCUIT TELEVISION	HPS	HIGH PRESSURE SODIUM	TRT	TRIPLE TUBE CF LAMP
CKT	CIRCUIT	IF	INSIDE FROSTED	TT	TWIN TUBE CF LAMP
CLK	CLOCK	KAIC	THOUSAND AMPERE INTERRUPTING CAPACITY	TV	TELEVISION
CTS	CIRCUIT TRANSFORMERS	KCMIL	THOUSAND CIRCULAR MILMETER	UH	UNIT HEATER
CU	CONDENSING UNIT	KVA	THOUSAND VOLT AMPERE	UON	UNLESS OTHERWISE NOTED
DISC SW	DISCONNECT SWITCH	MCB	MAIN CIRCUIT BREAKER	V	VOLT
EDF	ELECTRIC DRINKING FOUNTAIN	MH	METAL HALIDE	VA	VOLT AMPERE
EF	EXHAUST FAN	MLO	MAIN LUGS ONLY	WG	WIRE GUARD
ELEC	ELECTRICAL	MCC	MOTOR CONTROL CENTER	WP	WEATHER PROOF
EPO	EMERGENCY POWER OFF	NC	NORMALLY CLOSED	XFMR	TRANSFORMER
EQUIP	EQUIPMENT	NEC	NATIONAL ELECTRICAL CODE		
EWH	ELECTRIC WATER HEATER	NEMA	NATIONAL ELECTRICAL MANUFACTURERS ASS'N		
EXIST	EXISTING	NIC	NOT IN CONTRACT		
FACP	FIRE ALARM CONTROL PANEL	NL	NIGHT LIGHT		

NOTES:

- EVERY SYMBOL SHOWN MAY NOT APPEAR ON DRAWINGS.
- DASHED ELECTRICAL EQUIPMENT GENERALLY INDICATES EXISTING EQUIPMENT.
- LONG-SHORT-SHORT-LONG DASHING GENERALLY INDICATES MATCHLINE OR DEFINES AREA FOR SPECIAL NOTE.

<p>CIRCUIT RELATED:</p> <p>→ LIGHTING OR POWER CIRCUIT(S). ARROW INDICATES HOME RUN, LONGER TICK(S) INDICATE NEUTRAL WIRE(S), SHORTER STRAIGHT TICK(S) INDICATE PHASE WIRE(S), SLANTED SHORTER TICK(S) INDICATE SWITCH LEG(S), DOT(S) INDICATE GROUNDING CONDUCTOR(S), DASHED WIRING (LONG-SHORT-LONG DASHES) INDICATES WIRING BELOW SLAB OR GRADE, DASHED WIRING (SERIES OF SHORT DASHES) INDICATES EXISTING WIRING, SLASH THROUGH ARROW INDICATES PARTIAL CIRCUIT, "D" ON HOMERUN ARROW INDICATES DEDICATED CIRCUIT. PROVIDE A SEPARATE NEUTRAL FOR EACH PHASE CONDUCTOR FOR ENTIRE LENGTH OF CIRCUIT FROM PANEL TO OUTLET. COUNT EACH NEUTRAL AS CURRENT-CARRYING AND GROUP A MAXIMUM OF SIX THINWIRE CONDUCTORS IN A SINGLE RACEWAY. GROUNDING CONDUCTOR IS NOT COUNTED.</p> <p>Ⓜ JUNCTION BOX.</p> <p>• POINT OF BRANCH CIRCUIT TAP FOR SEPARATELY SWITCHED FIXTURE GROUP.</p> <p>Ⓜ REFERENCE CATEGORY "B" LIGHTING SYMBOLS FOR FURTHER INFORMATION.</p> <p>Ⓜ GROUNDING ELECTRODE.</p>	<p>POWER OUTLETS:</p> <p>Ⓜ 20A-125V DUPLEX RECEPTACLE. "GF" INDICATES GROUND FAULT CIRCUIT INTERRUPTER RECEPTACLE.</p> <p>Ⓜ 20A-125V FOURPLEX RECEPTACLE.</p> <p>Ⓜ SPECIAL PURPOSE SINGLE POWER RECEPTACLE. RATED AS INDICATED (IF NO RATING INDICATED, RECEPTACLE RATING SHALL MATCH BRANCH CIRCUIT OVERCURRENT PROTECTIVE DEVICE SIZE AND SHALL MEET REQUIREMENTS OF EQUIPMENT BEING CONNECTED), "C" INDICATES CLOCK OUTLET.</p> <p>Ⓜ SPECIAL PURPOSE RECEPTACLE.</p> <p>Ⓜ SAME AS DUPLEX RECEPTACLE EXCEPT ISOLATED GROUND TYPE RECEPTACLE.</p> <p>Ⓜ SAME AS FOURPLEX RECEPTACLE EXCEPT ISOLATED GROUND TYPE RECEPTACLE.</p> <p>AC INDICATES RECEPTACLE SHALL BE MOUNTED ABOVE COUNTER TOP. REFER TO ARCHITECT FOR EXACT HEIGHT ABOVE COUNTER.</p> <p>LC1-X CIRCUIT DESIGNATION NEXT TO RECEPTACLE DEVICES INDICATES BRANCH CIRCUIT NUMBER. RE: PANEL SCHEDULES FOR INFORMATION.</p> <p>WP "WP" INDICATES WEATHER PROOF DEVICE.</p>
<p>LIGHTING:</p> <p>☐ LIGHTING FIXTURE. LETTER INDICATES TYPE.</p> <p>☐ STRIP TYPE LIGHTING FIXTURE. LETTER INDICATES TYPE.</p> <p>☐ LED DOWNLIGHT FIXTURE. LETTER INDICATES TYPE.</p> <p>○ WALL OR BRACKET MOUNTED FIXTURE OR DEVICE.</p> <p>☐ EXIT LIGHT FIXTURE. LETTER INDICATES TYPE. PROVIDE CHEVRON DIRECTIONAL INDICATORS AS SHOWN ON DRAWINGS.</p> <p>CLG.</p>	<p>EQUIPMENT:</p> <p>42" A NOTATION INDICATING THE MOUNTING HEIGHT OF A DEVICE AS MEASURED FROM FINISHED FLOOR OR GRADE TO CENTER LINE OF DEVICE.</p> <p>Ⓜ MOTOR.</p> <p>☐ DISCONNECT SWITCH. FRAME SIZE/FUSE SIZE/POLES AS INDICATED. "NF" INDICATES NON-FUSIBLE. NEMA 1 ENCLOSURE UNLESS OTHERWISE NOTED. PROVIDE FUSED BUSWAY PLUG WHEN SWITCH IS INDICATED ON BUSWAY. ALL DISCONNECT SWITCHES SHALL BE 30NF/3 UNLESS OTHERWISE NOTED.</p> <p>☐ SINGLE CIRCUIT BREAKER IN INDIVIDUAL ENCLOSURE.</p> <p>☐ MAGNETIC MOTOR CONTROLLER. NUMBER INDICATES NEMA SIZE. STARTER NEMA SIZE SHALL BE "NEMA 1" UNLESS OTHERWISE NOTED.</p> <p>☐ COMBINATION DISCONNECT SWITCH/MOTOR CONTROLLER.</p> <p>☐ CONTACTOR</p> <p>☐ PANELBOARD SWITCHBOARD/DP</p> <p>☐ TRANSFORMER</p> <p>Ⓜ GROUNDING CONNECTION TO GROUNDING ELECTRODE AS DEFINED IN NEC ARTICLE 250.</p> <p>☐ BELL. "WP" INDICATES OUTDOOR RATED.</p>
<p>CONTROL:</p> <p>Ⓜ SWITCH. SMALL LETTER INDICATES FIXTURES CONTROLLED, "TR" INDICATES TAMPER RESISTANT, "P" INDICATES PILOT LIGHT, "WP" INDICATES WEATHERPROOF, "K" INDICATES KEY OPERATED, "MO" INDICATES SPDT MOMENTARY CONTACT, "VS" INDICATES VACANCY SENSOR, "OS" INDICATES OCCUPANCY SENSOR, "LO" INDICATES DIGITAL LOW VOLTAGE "ON" ONLY SWITCH, "Z" INDICATES DPDT, "S" INDICATES 3-WAY, "4" INDICATES 4-WAY, "M" INDICATES MANUAL MOTOR STARTER, CIRCUIT DESIGNATION NEXT TO SWITCH INDICATES BRANCH CIRCUIT NUMBER.</p> <p>Ⓜ WALL BOX DIMMER SWITCH. "3D" INDICATES 3-WAY DIMMER.</p> <p>Ⓜ DIGITAL TIME SWITCH</p> <p>☐ PHOTOELECTRIC CONTROL</p> <p>☐ EMERGENCY POWER OFF (EPO) PUSHBUTTON.</p> <p>☐ PUSH BUTTON.</p> <p>Ⓜ WALL MOUNT OCCUPANCY SENSOR.</p> <p>Ⓜ DUAL TECHNOLOGY CEILING MOUNTED OCCUPANCY SENSOR.</p> <p>Ⓜ DUAL TECHNOLOGY CEILING MOUNTED DAYLIGHT SENSOR.</p> <p>Ⓜ CEILING MOUNTED HIGH CEILING OCCUPANCY SENSOR.</p> <p>Ⓜ DIGITAL LIGHTING ROOM CONTROLLER.</p> <p>Ⓜ DIGITAL LIGHTING NETWORK BRIDGE.</p>	<p>LINE TYPES:</p> <p>SITE PLAN:</p> <p>— O — OVERHEAD ELECTRICAL LINES.</p> <p>— U — UNDERGROUND ELECTRICAL PRIMARY.</p> <p>— S — UNDERGROUND ELECTRICAL SECONDARY.</p> <p>FLOOR PLANS:</p> <p>— — — LIGHTING SWITCH LEG.</p> <p>— — — LOW VOLTAGE WIRING.</p> <p>— — — DAYLIGHT LIGHTING ZONE INDICATION.</p> <p>— — — POWER SUPPLY LINES.</p>

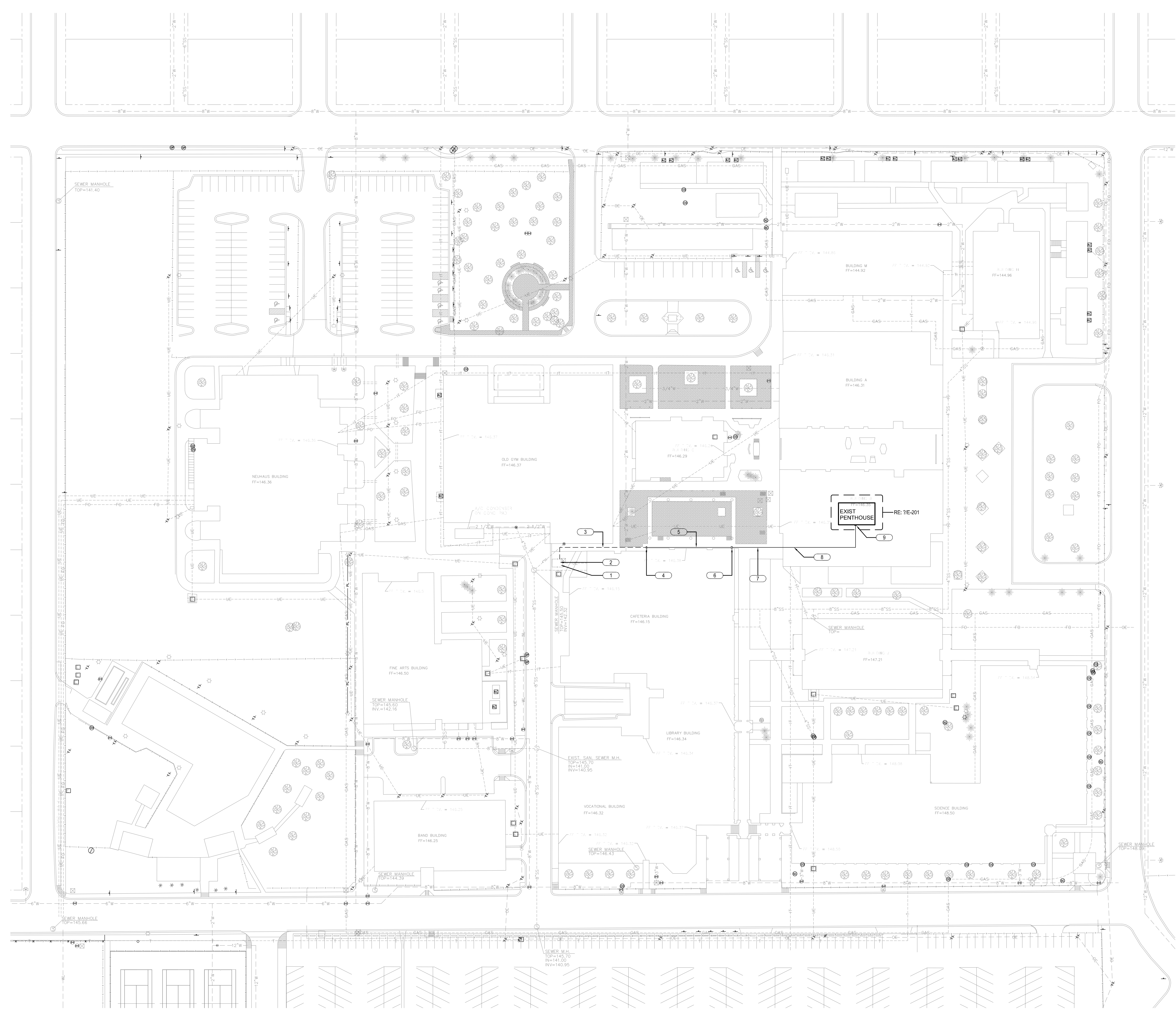

GENERAL NOTES

- COORDINATE ANY AND POWER OUTAGES WITH OWNER MIN. 72 HOURS PRIOR TO OUTAGE.
- CONTRACTOR TO COORDINATE EXACT CONDUIT ROUTING WITH OWNER AND EXISTING SITE UTILITIES PRIOR TO THE START OF CONSTRUCTION TO DETERMINE THE MOST COST EFFECTIVE AND UNOBTRUSIVE PATHWAY.

KEYED NOTES - ELECTRICAL

- APPROXIMATE LOCATION OF EXISTING 2000A, 277480V, NEMA-3R SWITCHBOARD "SB1".
- INSTALL NEW 175AMP CIRCUIT BREAKER IN AVAILABLE SPACE IN "SB1". NEW CIRCUIT BREAKER SHALL BE OF THE SAME MANUFACTURER AND COMPATIBLE WITH THE EXISTING SWITCHBOARD. NEW BREAKER SHALL HAVE AN AIC RATING TO MATCH EXISTING "SB1".
- ROUTE NEW FEEDER CONSISTING OF 3 #30, #6GND, 2 1/2" CONDUIT FOR TRANSFORMER T.L.C UNDERGROUND FROM EXISTING "SB1" BETWEEN BUILDINGS AND STUB UP NEXT TO EXISTING BUILDING.
- ROUTE FEEDER UP EXTERIOR WALL OF EXISTING BUILDING TO NEW NEMA-3R PULL BOX AT ROOF HEIGHT.
- ROUTE NEW FEEDER FROM PULL BOX ACROSS ROOF.
- ROUTE NEW FEEDER DOWN EXTERIOR WALL TO CANOPY BELOW.
- ROUTE NEW FEEDER ACROSS ROOF OF EXISTING CANOPY TO ROOF OF EXISTING BUILDING "B" AS INDICATED. CONTRACTOR TO COORDINATE EXACT ROUTING WITH OWNER AND EXISTING CONDITIONS PRIOR TO THE START OF CONSTRUCTION.
- ROUTE NEW FEEDER ACROSS ROOF OF EXISTING BUILDING B AND UP EXTERIOR WALL OF PENTHOUSE TO PULL BOX ON EXISTING PENTHOUSE.
- EXTEND FEEDER FROM PULLBOX ON EXTERIOR WALL THROUGH THE WALL INTO THE PENTHOUSE AND TERMINATE AT NEW TRANSFORMER T.L.C.

1 ELECTRICAL SITE PLAN
SCALE: NONE



ARCHITECT PBK Architects, Inc.
 SAN ANTONIO
 601 N.W. Loop 410, Suite 400
 San Antonio, TX 78216
 210-829-0123 P
 210-829-0578 F
 TX Firm: BS-1688
 PBK.com



LEAF ENGINEERS
 100
 1313-68-7200

MCSID - MISSION HS CULINARY ARTS

1802 CLEO DAWSON ST
 MISSION, TX 78572
 ISSUE FOR CONSTRUCTION



KEY PLAN:

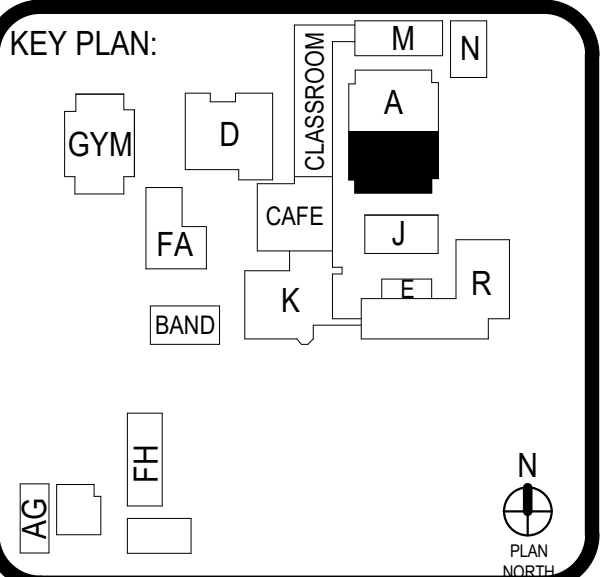

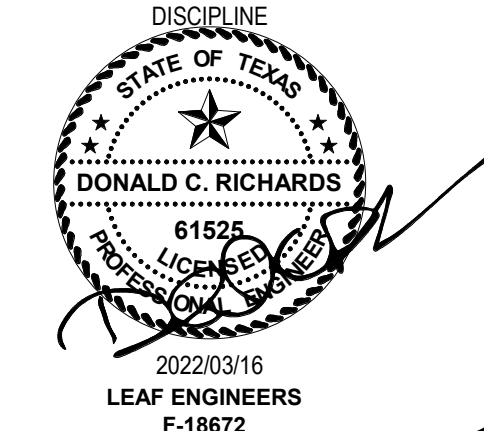

DONALD C. RICHARDS
 815
 20220316
 LEAF ENGINEERS
 F-18872

CLIENT		MCSID
DATE	2022/03/16	PROJECT NUMBER
		P2132600AR
DRAWING HISTORY		
No.	Description	Date

ISSUE FOR CONSTRUCTION

BUILDING NUMBER

ELECTRICAL SITE PLAN



601 N.W. LOOP 410, SUITE 400
 SAN ANTONIO, TX 78216
 210-638-7200
 TX Firm: F-18872

E-101

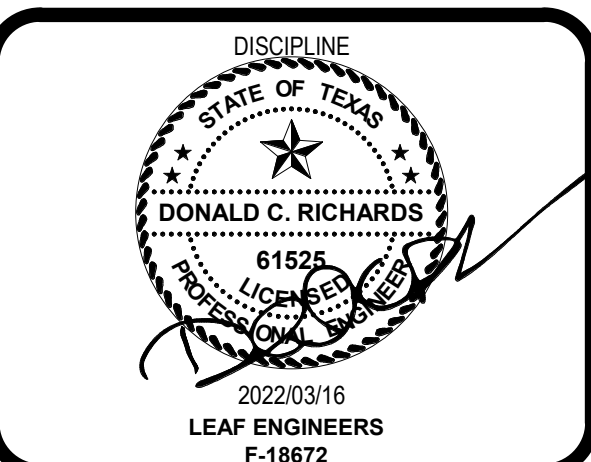
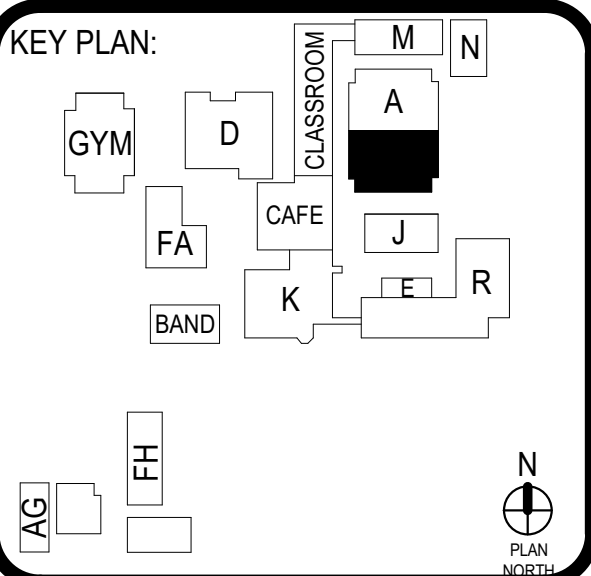

CLIENT		MCSID
DATE	2022/03/16	PROJECT NUMBER
		P2132600AR
DRAWING HISTORY		
No.	Description	Date

ISSUE FOR CONSTRUCTION

BUILDING NUMBER

GENERAL NOTES - POWER PLAN

- FOR EQUIPMENT OR DEVICES SHOWN ON THE ARCHITECTURAL DRAWINGS THAT REQUIRE POWER AND ARE NOT SHOWN ON THE ELECTRICAL PLANS, ASSUME AT A MINIMUM A DUPLEX RECEPTACLE, A DEDICATED CIRCUIT WITH 2412P12, 3412C WITH HOMERUN TO NEAREST 120/208V PANEL. ITEM SUCH AS BUT NOT LIMITED TO: ROLL UP DOORS, OVERHEAD GRILLES, DISPLAY CASES, HAND DRYERS, WATER COOLERS, ICE MACHINES, GARBAGE DISPOSALS, OSCILLATING FANS, LCD'S, PROJECTORS, DISHWASHERS, UNDER COUNTER REFRIGERATORS, MOTORIZED PROTECTION SCREENS, ETC.
- INSTALL ALL RECEPTACLES 18" AFF, UNLESS OTHERWISE NOTED.
- COORDINATE ROUGH-IN LOCATION OF DEVICES WITH ARCHITECTURAL ELEVATIONS, DETAILS AND PLANS. INSTALL DEVICE BOXES FLUSH WITH FINISHED SURFACE.
- INSTALL A DEDICATED NEUTRAL FOR EACH 120V OR 277V BRANCH CIRCUIT.

KEYED NOTES - POWER PLAN

- EP1 REMOVE ALL EXISTING ELECTRICAL OUTLETS IN SPACE IN THEIR ENTIRETY. REMOVE ALL ASSOCIATED BRANCH CIRCUIT WIRING IN ITS ENTIRETY BACK TO SOURCE. EXISTING CIRCUIT BREAKERS IN PANEL SHALL BE RELABELED AS 'SPARE'. INSTALL BLANK COVERPLATES ON ALL BOXES NOT BEING REUSED.
- EP2 ALL NEW ELECTRICAL DEVICES INSTALL IN SPACE ON EXISTING WALLS. SHALL BE SURFACE MOUNTED WITH SURFACE MOUNTED CONDUIT.
- EP3 INSTALL 250V, N6-30R RECEPTACLE WITH 3/8" #10GND, 1" C FOR OWNER PROVIDED OVEN. COORDINATE EXACT PLUG CONFIGURATION AND ROUGH-IN REQUIREMENTS WITH OWNER FURNISHED EQUIPMENT PRIOR TO INSTALLATION.
- EP4 INSTALL 250V, N6-30R RECEPTACLE WITH 3/8" #10GND, 1" C FOR OWNER PROVIDED CLOTHES WASHER/DRYER. COORDINATE EXACT PLUG CONFIGURATION AND ROUGH-IN REQUIREMENTS WITH OWNER FURNISHED EQUIPMENT PRIOR TO INSTALLATION.
- EP5 CONNECTION FOR RANGE EXHAUST HOOD ABOVE CEILING. COORDINATE EXACT MOUNTING HEIGHT AND ROUGH-IN REQUIREMENTS WITH HOOD MANUFACTURER'S INSTALLATION INSTRUCTIONS AND WIRING DIAGRAMS.
- EP6 INSTALL 20A, 120V, DUPLEX RECEPTACLE FOR EXHAUST HOOD AT 7'-0" AFF OR HEIGHT AS REQUIRED FOR INSTALLATION OF HOOD. INSTALL IN ACCORDANCE WITH HOOD MANUFACTURER'S INSTALLATION INSTRUCTIONS.
- EP7 INSTALL 120V, 20A, DUPLEX RECEPTACLE HORIZONTALLY IN BACKSPLASH ABOVE COUNTER. COORDINATE EXACT HEIGHT WITH CASEWORK AND ARCHITECT PRIOR TO INSTALLATION.
- EP8 EXTEND CONDUITS EXPOSED DOWN WALL, UNDERFLOOR AND STUB UP IN WALL OF ISLAND. SAWCUT FLOOR AS REQUIRED FOR INSTALLATION OF CONDUITS FOR ISLAND. CONTRACTOR TO BACKFILL, PATCH AND REPAIR CONCRETE FLOOR AS REQUIRED TO MATCH EXISTING CONDITIONS.
- EP9 INSTALL HEAVY DUTY, 400A, NEMA-1, FUSED DISCONNECT SWITCH WITH 400A FUSES ON HDG STEE "C" CHANNEL SUPPORT RACK. CONTRACTOR TO SUPPORT "C" CHANNEL SUPPORTS FROM STRUCTURE AND ANCHOR TO FLOOR. CONTRACTOR SHALL COORDINATE EXACT LOCATION WITH OWNER AND EXISTING CONDITIONS PRIOR TO INSTALLATION.
- EP10 INSTALL NEW 112.5KVA TRANSFORMER ON 4" CONCRETE HOUSEKEEPING PAD AT THIS APPROXIMATE LOCATION. CONTRACTOR SHALL COORDINATE EXACT LOCATION WITH OWNER AND EXISTING CONDITIONS PRIOR TO INSTALLATION.
- EP11 INSTALL FEEDER CONDUIT OVERHEAD FROM EXTERIOR TO LOCATION OF NEW TRANSFORMER AND TERMINATE AT TRANSFORMER.
- EP12 NEW ELECTRICAL PULLBOX ON WALL OF MEZZANINE FOR TRANSFORMER FEEDER. SEE SITE PLAN FOR ADDITIONAL INFORMATION.
- EP13 INSTALL 250V, N6-30R RECEPTACLE WITH 3/8" #10GND, 1" C FOR TOASTER OVEN. COORDINATE EXACT PLUG CONFIGURATION AND ROUGH-IN REQUIREMENTS WITH OWNER FURNISHED EQUIPMENT PRIOR TO INSTALLATION.

GENERAL NOTES - LIGHTING PLAN

- REFER TO ARCHITECTURAL REFLECTED CEILING PLAN (RCP) FOR EXACT LOCATION OF LIGHT FIXTURES. WHERE DISCREPANCIES EXIST THE LIGHTING SHOWN ON THIS PLAN SHALL GOVERN. FURNISH FIXTURES WITH TRIM COMPATIBLE WITH THE TYPE OF CEILING AS INDICATED ON THE RCP.
- COORDINATE PLACEMENT OF FIXTURES WITH ACTUAL INSTALLATION OF MECHANICAL EQUIPMENT AND DUCTWORK.
- INSTALL A DEDICATED NEUTRAL FOR EACH 120V OR 277V BRANCH CIRCUIT.
- ALL EXIT LIGHTS SHALL BE CONNECTED TO THE UN-SWITCHED PHASE CONDUCTOR (CONSTANT HOT) OF THE CIRCUIT SERVING THE LIGHTING FIXTURES WITHIN THE SPACE. TAP UN-SWITCHED HOT/LEG AHEAD OF LIGHTING CONTROL PANEL OR CONTROLLER.
- CONNECT EMERGENCY BATTERY UNITS IN LIGHTING FIXTURES TO THE UN-SWITCHED PHASE CONDUCTOR (CONSTANT HOT) OF THE CIRCUIT SERVING THE FIXTURES. TAP UN-SWITCHED HOT/LEG AHEAD OF LIGHTING CONTROL PANEL OR CONTROLLER.
- ALL LIGHT SWITCHES AND WALL SWITCH OCCUPANCY SENSORS SHALL BE INSTALLED ON THE STRIKE SIDE OF DOOR. COORDINATE EXACT LOCATION WITH ARCHITECTURAL DRAWINGS PRIOR TO START OF CONSTRUCTION AND FINAL DOOR LOCATIONS IN FIELD.
- CONTRACTOR SHALL COORDINATE EXACT LOCATIONS, MOUNTING HEIGHTS OF THE EXIT SIGNS AND THE DIRECTIONAL CHEVRONS WITH THE ARCHITECT'S EGRESS PLAN PRIOR TO INSTALLATION.

KEYED NOTES - LIGHTING PLAN

- EL1 LOW VOLTAGE CEILING MOUNTED OCCUPANCY SENSOR. SEE ELECTRICAL DETAILS AND SPECIFICATIONS 26 09 43.
- EL2 CLASS 2, CAT 5E CABLING FROM AREA LIGHTING CONTROLLER TO ROOM OCCUPANCY SENSOR AND WALL CONTROLLER. SEE DETAILS AND SPECIFICATIONS 26 09 23.
- EL4 LOW VOLTAGE WALL CONTROLLER WITH DIMMER. SEE DETAILS AND SPECIFICATIONS 26 09 43. INSTALL IN EXISTING LIGHTING BACKBOX AND ROUTE CAT5E CABLE IN EXISTING CONDUIT AND TERMINATE AT DEVICE.
- EL5 SERVE FROM EXISTING LIGHTING CIRCUIT SERVING EXISTING LIGHTING REMOVED DURING DEMOLITION PHASE.

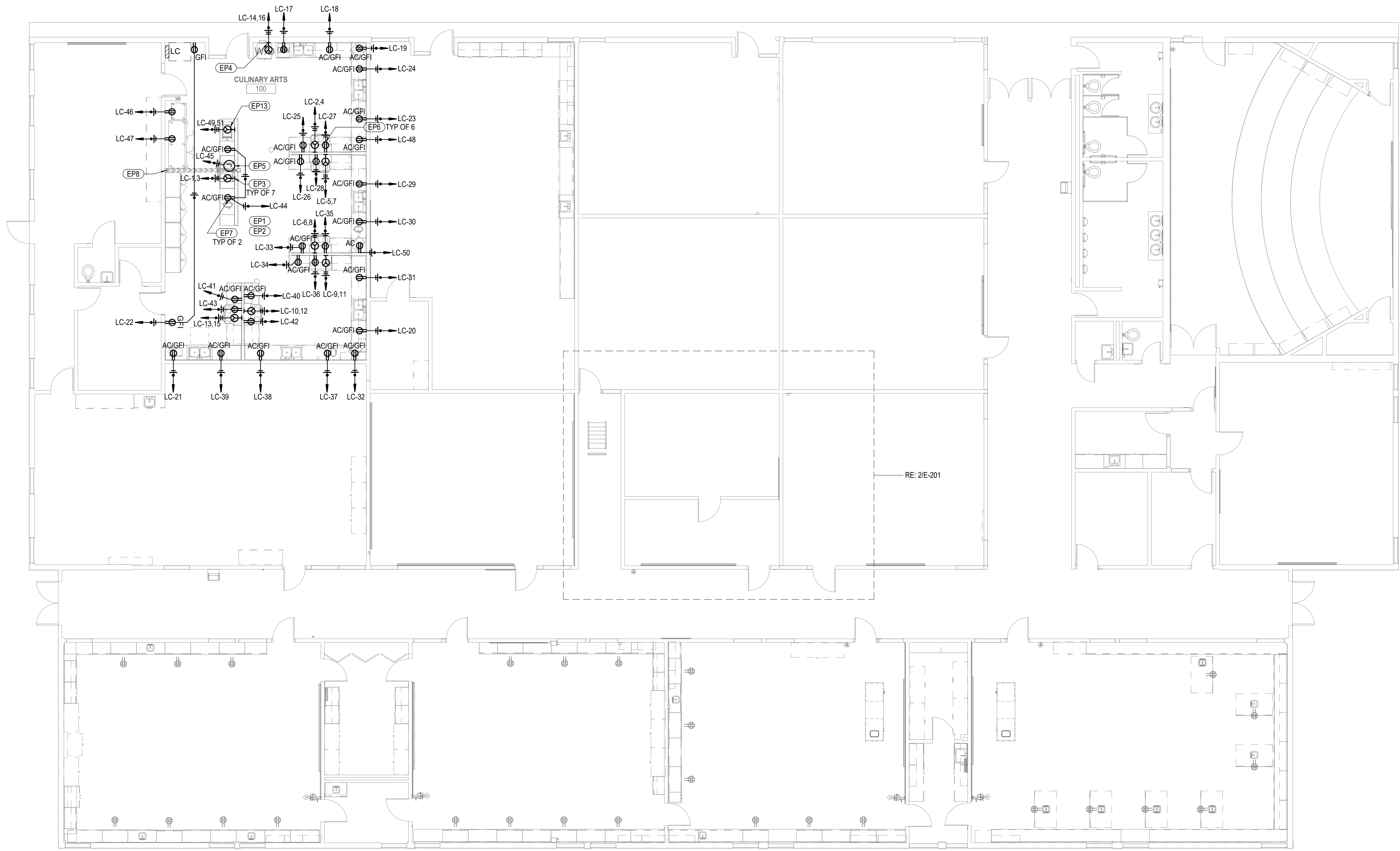

1 ELECTRICAL POWER PLAN
 SCALE: 1/8" = 1'-0"

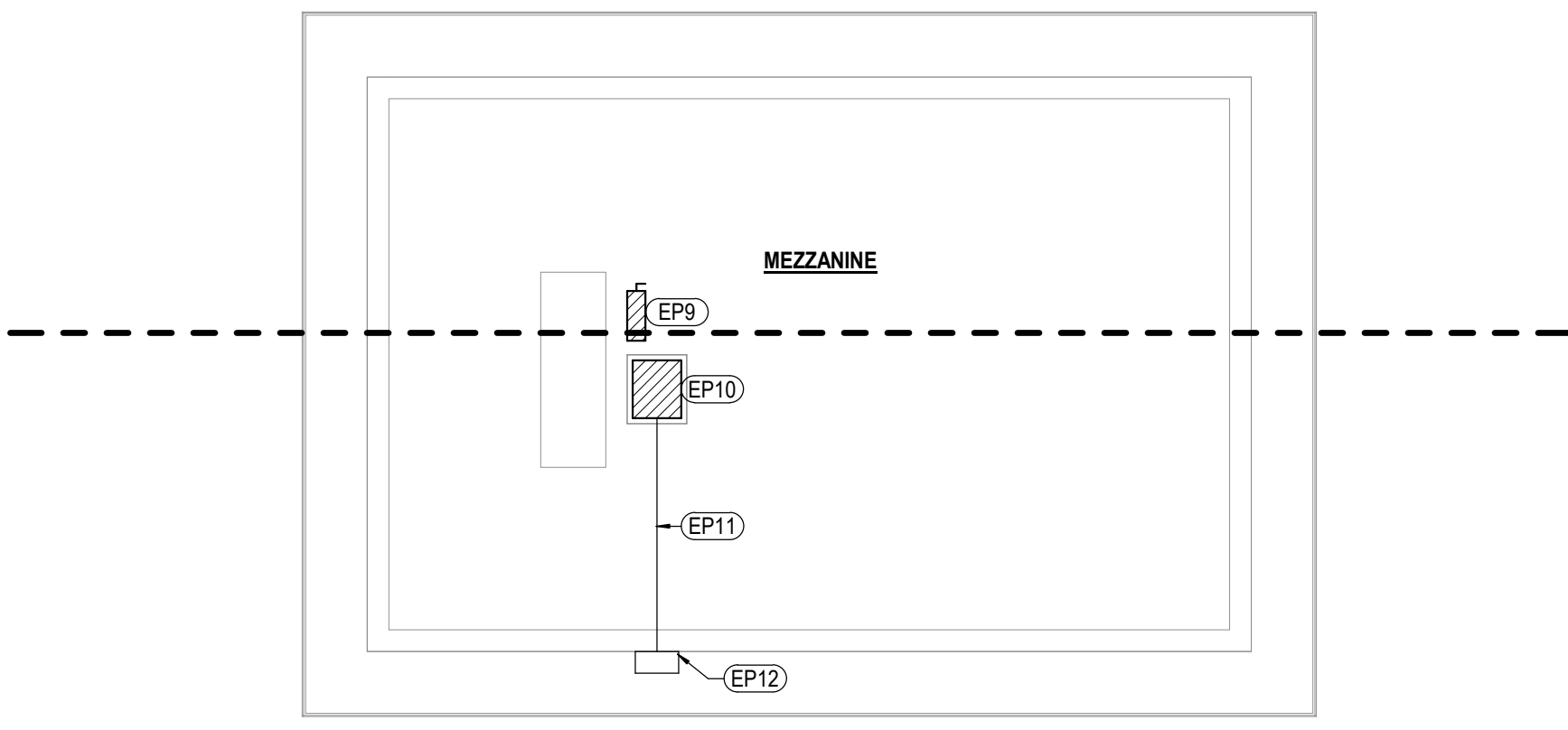

2 ELECTRICAL POWER PLAN - MEZZANINE
 SCALE: 1/8" = 1'-0"

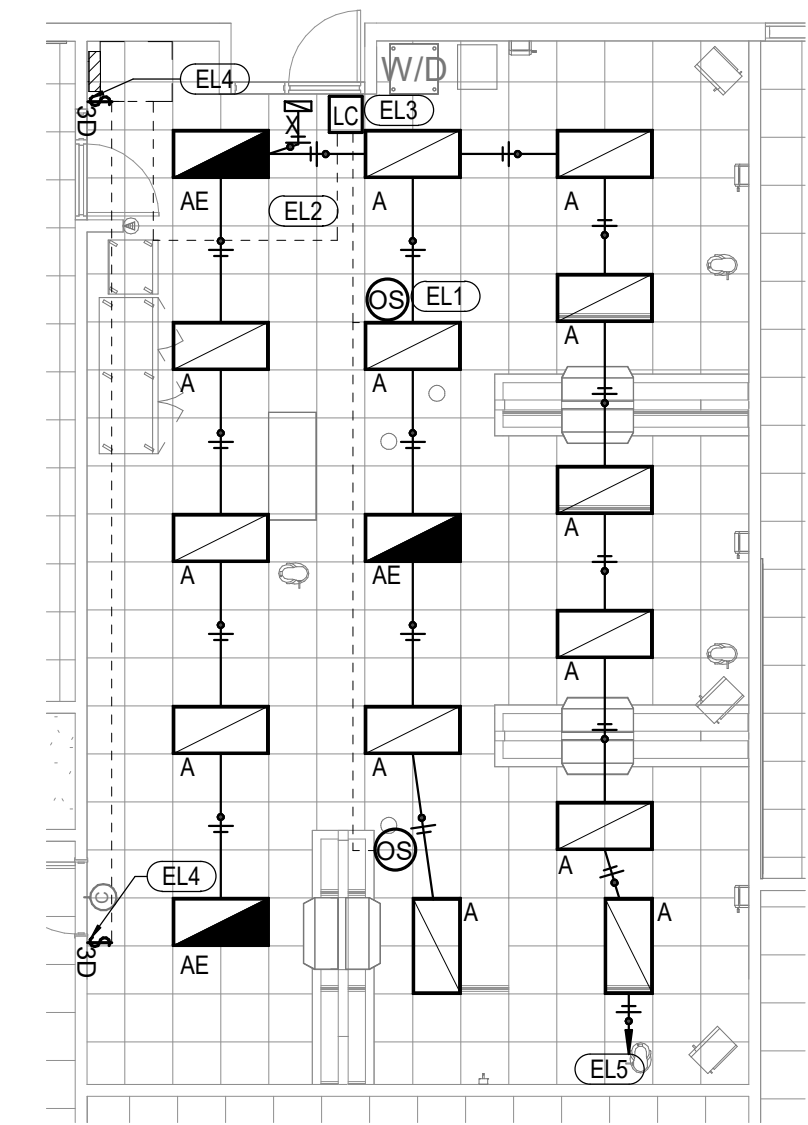

3 ELECTRICAL LIGHTING PLAN
 SCALE: 1/8" = 1'-0"

E-501
FOR BLUEBEAM LABELING ONLY
ELECTRICAL ONE LINE DIAGRAM, SCHEDULES & DETAILS

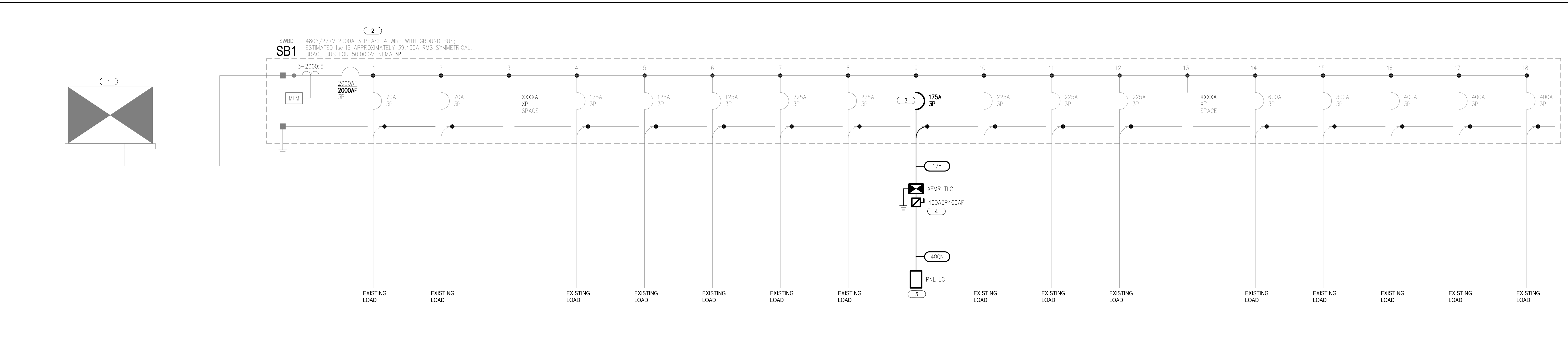

LOAD ANALYSIS
EX. LOAD (PER OWNER RECORD DRAWINGS EST. PEAK DEMAND WAS 996 KW)
996 KW / 0.88 PF = 1134 KVA X 1000 X 1.25 = 1417614 VA

LOADS REMOVED:

LIGHTING -	1275 VA	X	1.00	=	1275 VA
RECEPTACLES -	3240 VA	X	1.00	=	3240 VA
TOTAL LOAD REMOVED -					4515 VA

LOADS ADDED:

LIGHTING -	2 EA	X	180 VA/EA	=	752 VA
RECEPTACLES -					360 VA
<10,000 VA					0 VA
>10,000 VA					0 VA
APPLIANCES -					97832 VA
OTHER -					0 VA

NET CALCULATED DEMAND = 1512043 VA
@ 480Y/277V 3 PH = 1819 A

THE EXISTING 2000 AMP SERVICE IS ADEQUATE FOR THE ADDED LOAD

FEEDER / BRANCH CIRCUIT SCHEDULE

MARK	RACEWAY	PHASE CONDUCTORS	NEUTRAL CONDUCTORS	GROUND CONDUCTORS	REMARKS
400N	2"	3 #3/0	1 #3/0	1 #6	TWO PARALLEL FEEDERS REQUIRED
175	2 1/2"	3 #3/0	---	1 #6	
	X	X X	X X	X X	X

TRANSFORMER SCHEDULE

MARK	KVA	PRIMARY VOLTAGE	SECONDARY VOLTAGE	GROUNDING ELECTRODE	REMARKS
TLC	112-1/2	480V DELTA	208Y/120 GND WYE	#1/0	---
	X	X	X	X	X
	X	X	X	X	X

KEYED NOTES - ONE LINE DIAGRAM

- EXISTING SERVICE TRANSFORMER.
- EXISTING 277/480V, 2000A, SWITCHBOARD SB1.
- INSTALL NEW 175A3P CIRCUIT BREAKER IN AVAILABLE SPACE IN EXISTING SWITCHBOARD SB1. NEW BREAKER SHALL BE OF THE SAME MANUFACTURER AND COMPATIBLE WITH THE EXISTING SWITCHBOARD. NEW BREAKER SHALL HAVE AN AIC RATING TO MATCH EXISTING.
- NEW TRANSFORMER AND SECONDARY SWITCH TO BE INSTALLED ON BUILDING B MEZZANINE. REFER TO DETAIL 3 BELOW FOR TRANSFORMER GROUNDING DETAIL.
- NEW PANEL LC TO BE INSTALLED IN NEW CULINARY CLASSROOM IN BUILDING B.

1 ELECTRICAL ONE-LINE DIAGRAM (EXISTING SB1 SERVICE)
SCALE: NONE

LIGHTING FIXTURE SCHEDULE

TYPE	MANUFACTURER & MODEL NUMBER	LAMPS	VA	VOLTAGE	DESCRIPTION	NOTES
A	METALUX #24GR-LD4-48-UNV-L840-CD1-U DAY-BRITE # 21G4L840F502FUNVDMIM LITHONIA #02TL4G48LMVOLTEZ1LP840 COLUMBIA # LJT-24-40-ML-G-FA12125-ED-U	LED	4000K	120/277	2' X 4' LAY-IN LED TROFFER WITH NOMINAL 0.125" THICK INVERTED PATTERN 12 ACRYLIC LENS, GASKETING BETWEEN LENS/DOOR, DOOR/FRAME & FRAME/CEILING	
AE	METALUX #24GR-LD4-48-UNV-L840-CD1-U DAY-BRITE # 21G4L840F502FUNVDMIMLED LITHONIA #2GL4G48LMVOLTEZ1LP840EL14L COLUMBIA # LJT-24-40-ML-G-FA12125-ED-U-ELL14	LED	4000K	120/277	2' X 4' LAY-IN LED TROFFER WITH NOMINAL 0.125" THICK INVERTED PATTERN 12 ACRYLIC LENS, GASKETING BETWEEN LENS/DOOR, DOOR/FRAME & FRAME/CEILING AND EMERGENCY BATTERY PACK	
X1	SURE-LITES #LPX-70-RWH CHLORIDE #ERWEM LITHONIA #LQMSWSG120277ELN COMPASS #CEG	LED		120/277	UNIVERSAL EXIT LIGHT WITH BATTERY, NUMBER OF FACES AND DIRECTIONAL CHEVRONS AS INDICATED ON THE DRAWINGS	

- GENERAL NOTES**
- COLOR TEMPERATURE SHALL BE 4000K UNLESS NOTED OTHERWISE.

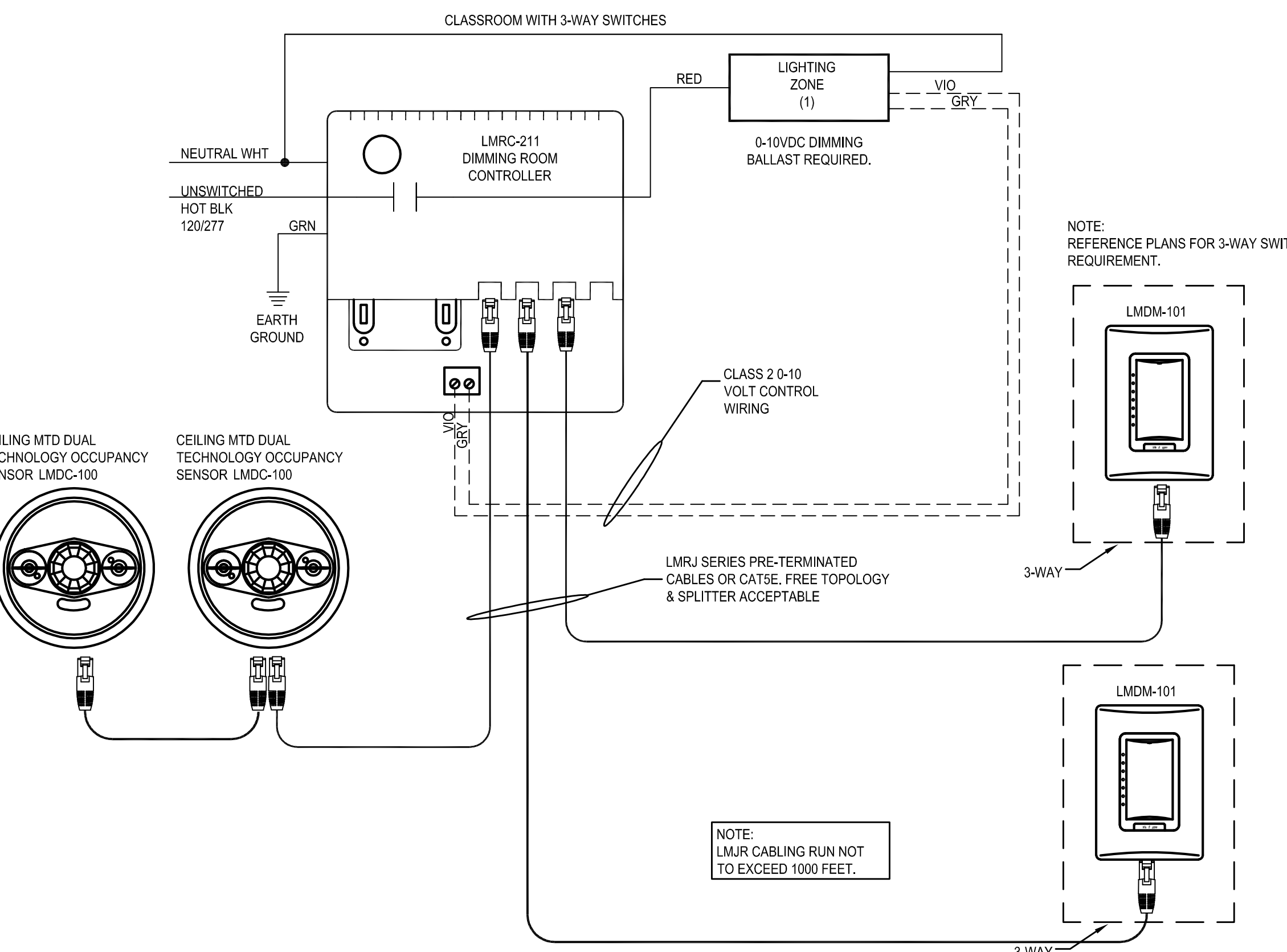

2 CULINARY CLASSROOM LIGHTING CONTROL DIAGRAM (3-WAY SWITCHING)
SCALE: NONE

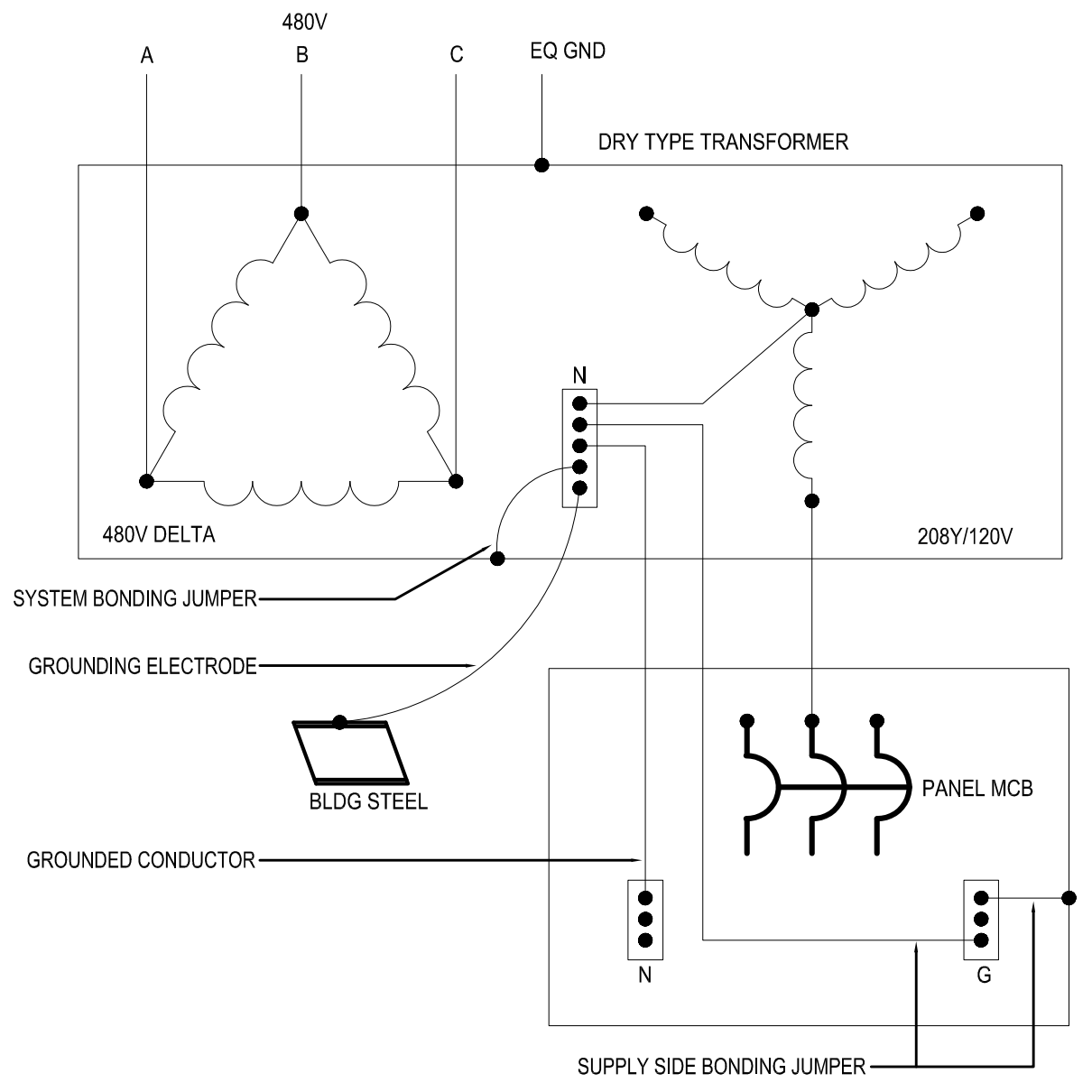

3 SEPARATELY DERIVED SYSTEM GROUNDING DETAIL
SCALE: NONE

PANELBOARD LC

VOLTAGE: 208Y/120 VOLT 3 PHASE 4 WIRE
400 A MAIN BREAKER
BUSES: MAIN - 400 A NEUTRAL - 100% EQUIPMENT GROUND

VAL.	VA	VAO	LOAD	BKR	CKT	CKT	BKR	LOAD	VAL.	VA	VAO	
0	0	4000	RANGE	502	1	A	2	502	RANGE	0	0	4000
0	0	4000	RANGE	502	3	B	4	502	RANGE	0	0	4000
0	0	4000	RANGE	502	5	A	6	502	RANGE	0	0	4000
0	0	4000	RANGE	502	7	B	8	502	RANGE	0	0	4000
0	0	4000	RANGE	502	9	B	10	502	RANGE	0	0	4000
0	0	4000	RANGE	502	11	C	12	502	RANGE	0	0	4000
0	0	4000	RANGE	502	13	A	14	302	WASHER/DRYER	0	0	2400
0	0	4000	RANGE	502	15	B	16	302	WASHER/DRYER	0	0	2400
0	0	1000	DISHWASHER	201	17	B	18	201	RECEPTACLES RM 100	0	0	1000
0	0	1000	RECEPTACLES RM 100	201	19	A	20	201	RECEPTACLES RM 100	0	0	1000
0	0	1000	RECEPTACLES RM 100	201	21	B	22	201	RECEPTACLES RM 100	0	0	1000
0	0	800	MIXER	201	23	C	24	201	RECEPTACLES RM 100	0	0	1000
0	0	800	MIXER	201	25	A	26	201	MIXER	0	0	800
0	0	1170	EXHAUST HOOD	201	27	B	28	201	EXHAUST HOOD	0	0	1170
0	0	1000	RECEPTACLES RM 100	201	29	A	30	201	MIXER	0	0	800
0	0	1000	MICROWAVE	201	31	A	32	201	MICROWAVE	0	0	1000
0	0	800	MIXER	201	33	B	34	201	MIXER	0	0	800
0	0	1170	EXHAUST HOOD	201	35	C	36	201	EXHAUST HOOD	0	0	1170
0	0	800	MIXER	201	37	A	38	201	RECEPTACLES RM 100	0	0	1000
0	0	1000	MICROWAVE	201	39	B	40	201	MIXER	0	0	800
0	0	1170	EXHAUST HOOD	201	41	B	42	201	EXHAUST HOOD	0	0	1170
0	0	1170	EXHAUST HOOD	201	43	A	44	201	MIXER	0	0	800
0	0	1800	REFRIGERATOR	201	45	B	46	201	REFRIGERATOR	0	0	1800
0	0	1700	MUFFIN TOASTER OVEN	201	47	A	48	201	RECEPTACLES RM 100	0	0	1000
0	0	1700	MUFFIN TOASTER OVEN	201	49	A	50	201	MICROWAVE	0	0	1000
0	0	SPARE	201	53	C	54	201	SPARE	0	0	0	
0	0	SPARE	201	55	A	56	201	SPARE	0	0	0	
0	0	SPARE	201	57	B	58	201	SPARE	0	0	0	
0	0	SPARE	201	59	A	60	201	SPARE	0	0	0	
0	0	SPARE	201	61	A	62	201	SPARE	0	0	0	
0	0	SPARE	201	63	B	64	201	SPARE	0	0	0	
0	0	SPARE	201	65	B	66	201	SPARE	0	0	0	
0	0	SPARE	201	67	A	68	201	SPARE	0	0	0	
0	0	SPARE	201	69	A	70	201	SPARE	0	0	0	
0	0	SPARE	201	71	B	72	201	SPARE	0	0	0	
0	0	SPARE	201	73	A	74	201	SPARE	0	0	0	
0	0	SPARE	201	75	A	76	201	SPARE	0	0	0	
0	0	SPARE	201	77	C	78	201	SPARE	0	0	0	
0	0	SPARE	201	79	A	80	201	SPARE	0	0	0	
0	0	SPARE	201	81	B	82	201	SPARE	0	0	0	
0	0	SPARE	201	83	C	84	201	SPARE	0	0	0	

VAL. (LIGHTING) 0 CONNECTED VA 0 DEMAND VA
VA (RECEPTACLES) 360 CONNECTED VA 360 DEMAND VA
VA (OTHER) 97832 CONNECTED VA 97832 DEMAND VA
VA TOTAL 98192 CONNECTED VA 98192 DEMAND VA
AMPS TOTAL 273 CONNECTED AMPS 273 DEMAND AMPS

TOTAL
L 0 R 0 O 0
VA CONNECTED TO A PHASE 34476 VA = 287 AMPS CONNECTED TO A PHASE @ 120 VOLTS
VA CONNECTED TO B PHASE 34198 VA = 285 AMPS CONNECTED TO B PHASE @ 120 VOLTS
VA CONNECTED TO C PHASE 29528 VA = 246 AMPS CONNECTED TO C PHASE @ 120 VOLTS
TOTAL 98192 VA

PLUMBING ABBREVIATION SCHEDULE

NOTES: 1. ALL ABBREVIATIONS MAY NOT BE USED ON THESE DRAWINGS.

AAP	AREA ALARM PANEL	MS	MOP SINK
AAV	AUTOMATIC AIR VENT	N.C.	NORMALLY CLOSED
A.F.F.	ABOVE FINISHED FLOOR	NIC	NOT IN CONTRACT
AP	ACCESS PANEL	N.O.	NORMALLY OPEN
B.F.F.	BELOW FINISHED FLOOR	O.F./C.I.	OWNER FURNISHED/CONTRACTOR INSTALLED
BFP	BACKFLOW PREVENTER	O.F./O.I.	OWNER FURNISHED/OWNER INSTALLED
BOB	BOTTOM OF BEAM	OFD	OVERFLOW DRAIN
BOP	BOTTOM OF PIPE	PH	PHASE
BTUH	BRITISH THERMAL UNITS PER HOUR	PIV	POST INDICATOR VALVE
CC	CUT AND CAP	PRV	PRESSURE REDUCING VALVE
CFH	CUBIC FEET PER HOUR	RD	ROOF DRAIN
CFM	CUBIC FEET PER SECOND	RE	REFER TO
CI	CAST IRON	R.I.C.	ROUGH-IN AND CONNECT
CLG	CEILING	RO	REVERSE OSMOSIS
CO	CLEANOUT	RP/BFP	REDUCED PRESSURE BACKFLOW PREVENTER
CONN	CONNECTION	RP	REVOLUTIONS PER MINUTE
CONT.	CONTINUATION	RVB	REFRIGERATOR VALVE BOX
DF	DRINKING FOUNTAIN	SD	STORM DRAIN
DPV	DRY PIPE VALVE	S.F.	SQUARE FEET
DWG.	DRAWING	SIA	SIA MESE
EA	EACH	SK	SINK
EDF	ELECTRIC DRINKING FOUNTAIN	T.O.P.	TOP OF PIPE
FCO	FLOOR CLEANOUT	TP	TRAP PRIMER
FD	FLOOR DRAIN	TYP	TYPICAL
FDV	FIRE DEPARTMENT VALVE	U	URINAL
F.F.	FINISHED FLOOR	UF	UNDERFLOOR
FHC	FIRE HOSE CABINET	UIS	UNDERSLAB
F.L.	FLOOR LINE	VAC BRKR	VACUUM BREAKER
FS	FLOOR SINK	VCT	VITRIFIED CLAY TILE
FT	FEET	VTR	VENT THRU ROOF
FU	FIXTURE UNITS	WC	WATER CLOSET
GC	GENERAL CONTRACTOR	WCO	WALL CLEANOUT
GPH	GALLONS PER HOUR	WH	WALL HYDRANT
GPM	GALLONS PER MINUTE	WMB	WASHING MACHINE BOX
HB	HOSE BIBB	YH	YARD HYDRANT
HP	HORSEPOWER	ZV	ZONE VALVE
I.E.	INVERT ELEVATION	(A)	ITEM NOTED TO BE ABANDONED
KW	KILOWATTS	(D)	ITEM NOTED TO BE DEMOLISHED
LAV	LAVATORY	(E)	EXISTING ITEM
MAP	MASTER ALARM PANEL	(N)	NEW ITEM
MECH	MECHANICAL	(R)	ITEM NOTED TO BE RELOCATED
MH	MANHOLE		

PLUMBING SYMBOLS LEGEND

NOTES: 1. ALL SYMBOLS MAY NOT BE USED ON THESE DRAWINGS.

SYMBOL	ABV.	DESCRIPTION
AW	AW	ACID WASTE
AV	AV	ACID VENT
B		BUTANE
CDWR		CHILLED DRINKING WATER RETURN
CDWS		CHILLED DRINKING WATER SUPPLY
D		DRAIN PIPING
DSP		DRY SPRINKLER PIPE
F	F	FIRE LINE
FOR		FUEL OIL RETURN
FOS	FOS	FUEL OIL SUPPLY
FOV	FOV	FUEL OIL VENT
G	G	NATURAL GAS PIPING
GW	GW	GREASE WASTE ABOVE SLAB
GW	GW	GREASE WASTE BELOW SLAB
OSD	OSD	STORM OVER FLOW DRAIN
P	P	PROPANE GAS PIPING
PSS	PSS	PUMPED SANITARY SEWER
PSD	PSD	PUMPED STORM SEWER
SD	SD	STORM DRAIN ABOVE SLAB
SD	SD	STORM DRAIN BELOW SLAB
SP	SP	SPRINKLER LINE
SS	SS	SANITARY SEWER ABOVE SLAB
SS	SS	SANITARY SEWER BELOW SLAB
SV	SV	SANITARY VENT
	CW	COLD WATER
	HW	HOT WATER
	HWR	HOT WATER RETURN
		DIRECTION OF FLOW
		DIRECTION OF SLOPE DOWN
		DROP IN PIPE
		RISE IN PIPE
		GATE VALVE
		BALL VALVE
		CHECK VALVE
		SUPERVISED VALVE WITH FLOW SWITCH
		SUPERVISED VALVE IN VERTICAL
		PLUG VALVE / GAS COCK
		BUTTERFLY VALVE
		BALANCING VALVE
		PIPE UNION
		PRESSURE CONTROL VALVE
		3-WAY VALVE
		SOLENOID VALVE
		FLOW SWITCH
		PRESSURE GAUGE WITH GAUGE COCK
		THERMOMETER
		ROOF DRAIN / OVERFLOW DRAIN
		FLOOR DRAIN
		FLOOR SINK
		T & P RELIEF VALVE
		STRAINER
CO	CO	END OF LINE CLEANOUT
FCO	FCO	FLOOR CLEANOUT
WCO	WCO	WALL CLEANOUT
		CAP
		FLEXIBLE CONNECTION
(E)		NEW CONNECTION TO EXISTING
(E)		EXISTING RISER

PLUMBING TESTING:

- ALL EQUIPMENT AND/OR SYSTEMS NOTED ON THE DRAWINGS TO REMAIN SHALL BE INSPECTED AND TESTED ON SITE TO CERTIFY WORKING CONDITION. A WRITTEN REPORT ON THE CONDITION OF ALL EQUIPMENT TO REMAIN, INCLUDING A COPY OF THE TEST RESULTS AND RECOMMENDED REMEDIAL ACTIONS AND COSTS SHALL BE MADE BY THIS CONTRACTOR TO THE ARCHITECT/ENGINEER FOR REVIEW.
- PIPE COVER AND BACKFILLING:
 - AFTER HYDROSTATIC TEST, EVENLY BACKFILL ENTIRE TRENCH WIDTH BY HAND PLACING BACKFILL MATERIAL AND HAND TAMPING IN FOUR (4) INCHES COMPACTED LAYERS TO 12 INCHES MINIMUM COVER OVER TOP OF JACKET. COMPACT TO 95 PERCENT MAXIMUM DENSITY.
 - EVENLY AND CONTINUOUSLY BACKFILL REMAINING TRENCH DEPTH IN UNIFORM LAYERS WITH BACKFILL MATERIAL.
 - DO NOT USE WHEELED OR TRACKED VEHICLES FOR TAMPING.
- PRESSURE TEST ALL DOMESTIC WATER PIPING, AFTER INSTALLATION AND PRIOR TO BACKFILL OR COVER UP. RISE PIPING SYSTEM OF PARTICULATE CONTAMINANTS, CAP AND SUBJECT TO STATIC WATER PRESSURE OF 125 PSIG FOR FOUR (4) HOURS. REPAIR LEAKS AND DEFECTS AND RE-TEST ANY PORTION OF PIPING SYSTEM THAT FAILS. PROVIDE WRITTEN TEST REPORT INCLUDING DATE AND TIME OF TEST, PASS OR FAIL INDICATION, SUMMARY OF REMEDIAL WORK REQUIRED AND DATE AND TIME OF EACH RE-TEST.
- PRIOR TO COVER UP, WATER PIPE, SANITARY PIPE, AND GAS PIPING SHALL BE PRESSURE TESTED. TESTS SHALL BE WITNESSED BY CONSULTANT AND OWNER. NOTIFY OWNER 48 HOURS PRIOR TO TEST. TEST SHALL BE WITNESSED BY CLIENT PLUMBING TECHNICIAN.
- UPON COMPLETION OF THE SANITARY PIPING SYSTEM, THE CONTRACTOR SHALL NOTIFY ENGINEER AND OWNER TO OBSERVE A SMOKE TEST OF THE SYSTEM. SMOKE TESTING SHALL BE PERFORMED ON SANITARY PIPING SYSTEM TWICE DURING CONSTRUCTION.
 - WATER TEST SHALL BE APPLIED TO THESE DRAINAGE SYSTEMS EITHER IN THEIR ENTIRETY OR IN SECTIONS AS REQUIRED, AFTER ROUGH PIPING HAS BEEN INSTALLED. IF THE SYSTEM IS TESTED IN SECTIONS, EACH OPENING IN THE SECTION UNDER TEST, ALL SECTIONS SHALL BE TESTED WITH A MINIMUM OF 10 FEET HEAD OF WATER. IN TESTING SUCCESSIVE SECTIONS AT LEAST THE UPPER 10 FEET OF THE NEXT PRECEDING SECTION SHALL BE TESTED SO THAT NO JOINT OF PIPING IN THE BUILDING EXCEPT THE UPPERMOST 10 FEET OF THE SYSTEM SHALL BE SUBMITTED TO A TEST OF LESS THAN A 10 FOOT OF HEAD WATER. THE WATER SHALL BE KEPT IN THE SYSTEM FOR AT LEAST 230 MINUTES BEFORE INSPECTIONS STARTS; THE SYSTEM SHALL THEN BE MADE TIGHT AT ALL POINTS.
 - ANY POINTS OF THE DRAINAGE SYSTEMS TO BE TESTED WITH AIR INSTEAD OF WATER SHALL BE MADE BY ATTACHING AN AIR COMPRESSOR TESTING APPARATUS TO ANY SUITABLE OPENING AND AFTER CLOSING ALL OTHER LETS, OUTLETS, FORCING AIR INTO THE SYSTEM UNTIL THERE IS A MINIMUM GAUGE PRESSURE OF 5 PSI. THIS PRESSURE SHALL BE HELD WITHOUT THE INTRODUCTION OF ADDITIONAL AIR FOR A PERIOD OF AT LEAST 30 MINUTES.
- EXTERIOR CONNECTIONS SHALL BE TESTED AS PART OF THE INTERIOR SYSTEMS.
 - PROVIDE ALL ADDITIONAL TEST SUCH AS SMOKE OR PRESSURE TESTS AS REQUIRED BY THE REGULATIONS OR AS DIRECTED BY AUTHORITIES MAKING THE INSPECTION.
 - PROVIDE FOR ANY REPEATED TEST AS DIRECTED BY THE OWNERS REPRESENTATIVE, TO MAKE ALL SYSTEMS TIGHT AS REQUIRED.
 - VISUAL INSPECTIONS OF JOINTS, VALVES, ETC. SHALL BE MADE AS DIRECTED BY THE ENGINEER.
 - PRESSURE TEST NATURAL GAS PIPING IN ACCORDANCE WITH NFPA 54. PRESSURE TEST PRIOR TO BACKFILL, MINIMUM 50PSI FOR 24 HOURS.

GENERAL NOTES:

- THE PLUMBING WORK SHALL BE PERFORMED IN STRICT ACCORDANCE WITH THE 2015 IPC & 2015 IFGC AS WELL AS ALL LOCAL REGULATIONS THAT MAY APPLY. IN CASE OF CONFLICT BETWEEN THE CONTRACT DOCUMENTS AND A GOVERNING CODE OR ORDINANCE THE MORE STRINGENT STANDARD SHALL APPLY.
- ALL PLUMBING WORK SHALL BE COORDINATED WITH ALL OTHER TRADES BEFORE PROCEEDING WITH THE INSTALLATION.
- INVERT ELEVATIONS AND EXACT LOCATIONS OF ALL EXISTING UTILITIES SHALL BE CHECKED BEFORE PROCEEDING WITH THE NEW WORK.
- NO CHANGES ARE TO BE MADE IN PLUMBING LAYOUT WITHOUT WRITTEN PERMISSION BY THE ARCHITECT OR ENGINEER.
- NO PIPING SHALL RUN EXPOSED IN FINISHED AREAS.
- ROUGH-IN DIMENSIONS OF TOILET FIXTURES MUST BE COORDINATED WITH THE GENERAL CONTRACTOR.
- PROVIDE SHUTOFF VALVES FOR WATER HEATER BRANCH. PROVIDE DIELECTRIC FITTINGS OR COUPLINGS WHEREVER DISSIMILAR METALS ARE JOINED.
- PROVIDE SHUTOFF VALVES AT EACH FIXTURE ON HOT AND COLD WATER SUPPLY PIPES.
- ALL ACCESS PANELS SHALL BE BY GENERAL CONTRACTOR. PLUMBING CONTRACTOR SHALL BE RESPONSIBLE FOR THEIR LOCATION.
- INSTALL ALL REQUIRED CLEANOUTS TO CLEAR EQUIPMENT AND FIXTURES.
- ALL WORK SHALL BE PROPERLY TESTED, BALANCED, AND CLEANED AND DISINFECTED. PROVIDE A ONE YEAR WARRANTY FROM DATE OF FINAL INSPECTION ON ALL PARTS AND LABOR.
- ALL PLUMBING FIXTURES SPECIFIED ARE FOR INFORMATION ONLY. EQUAL EQUIPMENT MAY BE INSTALLED SECURING FIRST THE ENGINEER'S APPROVAL.
- PITCH ALL WASTE AND SOIL PIPING AT MAXIMUM SLOPE POSSIBLE, BUT NOT LESS THAN 1/4" PER FOOT FOR PIPING 3" AND UNDER AND NO LESS THAN 1/8" FOR PIPING 4" AND GREATER.
- PROVIDE ALL PIPE OPENINGS THROUGH PARTITIONS WITH PIPE SLEEVES. PENETRATING FIRE RATED PARTITIONS, THE SPACE BETWEEN THE PIPE AND THE SLEEVE SHALL BE SEALED WITH FIRE STOPPING MATERIAL.
- ANY UNAUTHORIZED CHANGES TO THE EQUIPMENT, DESIGN, OR INSTALLATION OF THE PLUMBING SYSTEMS WITHOUT THE EXPRESSED WRITTEN CONSENT OF THE ENGINEER IS UNACCEPTABLE AND GROUNDS FOR REMOVAL OF ALL LIABILITY OF THE ARCHITECT/ENGINEER FOR THE REVISED DESIGN.
- PROVIDE CONDENSATE DRAIN FROM ROOF MOUNTED EQUIPMENT TO OPEN SITE DRAIN OR AS SHOWN.
- ALL PIPING MATERIAL SHALL BE OF DOMESTIC MANUFACTURE AND SHALL COMPLY WITH THE BUY AMERICAN ACT.

PLUMBING PIPING MATERIAL SCHEDULE

SYSTEM	BELOW GRADE	ABOVE GRADE
WASTE AND VENT	SCH 40 PVC	CAST IRON
DOMESTIC WATER PIPING	TYPE K COPPER	TYPE L COPPER

DRAWING REFERENCE KEY

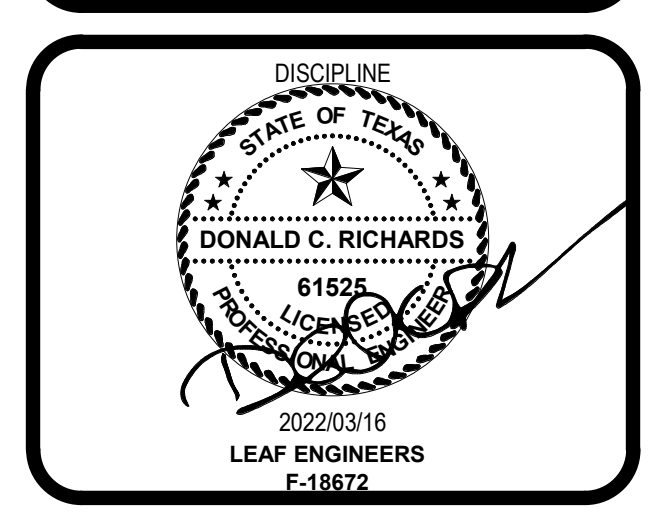
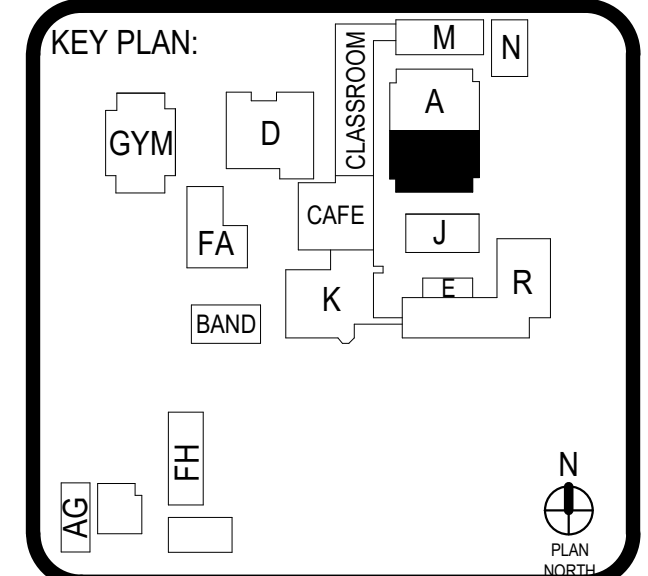
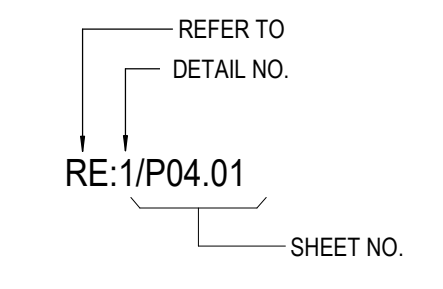

CLIENT MCSID		
DATE 2022/03/16	PROJECT NUMBER P2132600AR	
DRAWING HISTORY		
No.	Description	Date

ISSUE FOR CONSTRUCTION

PLUMBING SYMBOLS AND ABBREVIATIONS

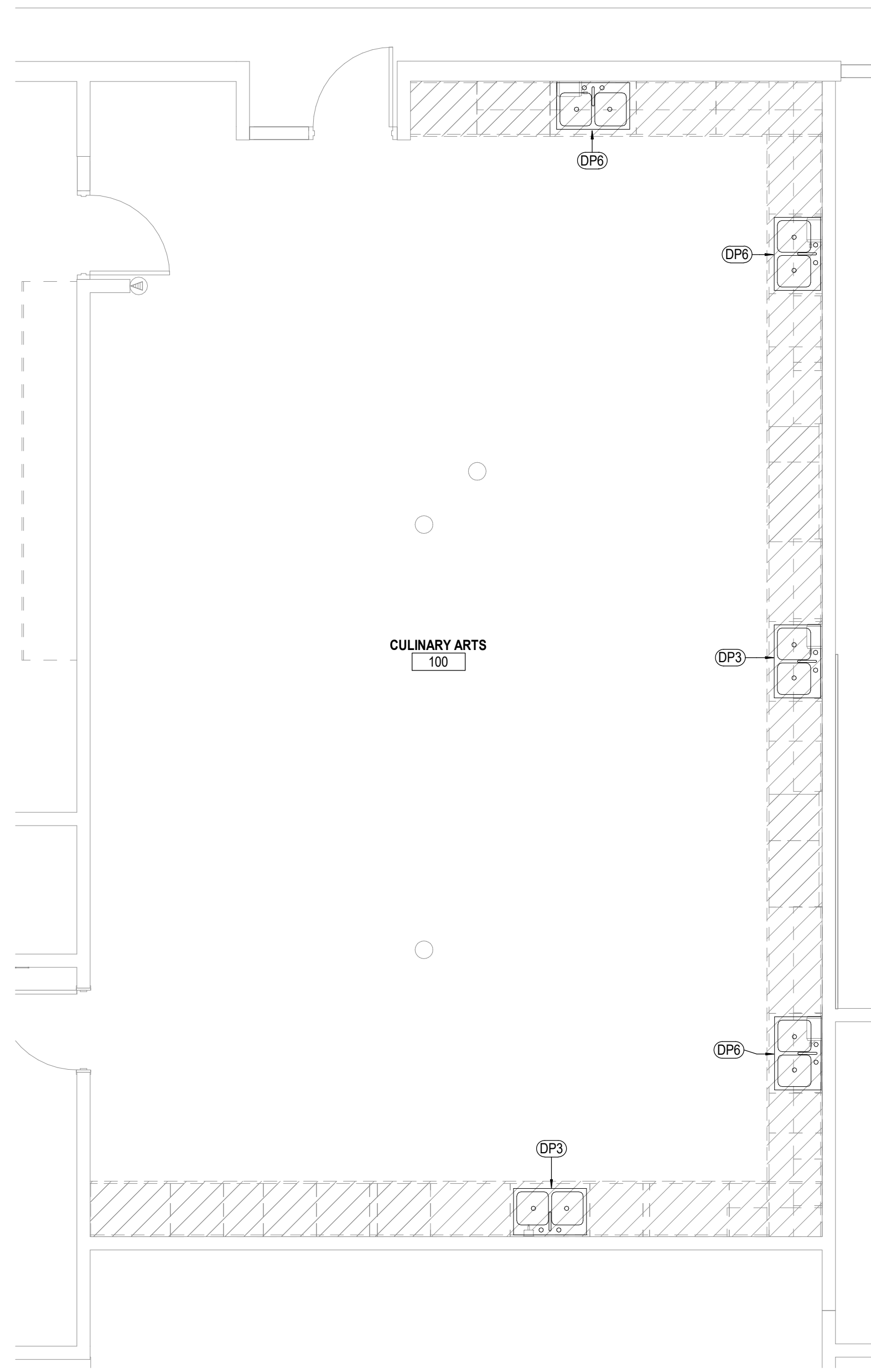

1 DEMOLITION PLUMBING PLAN
SCALE: 1/4" = 1'-0"

- KEYED NOTES - PLUMBING DEMO PLAN**
- DP3 EXISTING SINK TO BE REMOVED AND ALL ASSOCIATED PIPING TO BE REMOVED BACK TO SOURCE.
 - DP6 EXISTING SINK TO BE REMOVED AND SAVED FOR REINSTALLATION. REFER TO ARCH. DWGS FOR ADDITIONAL NOTES.

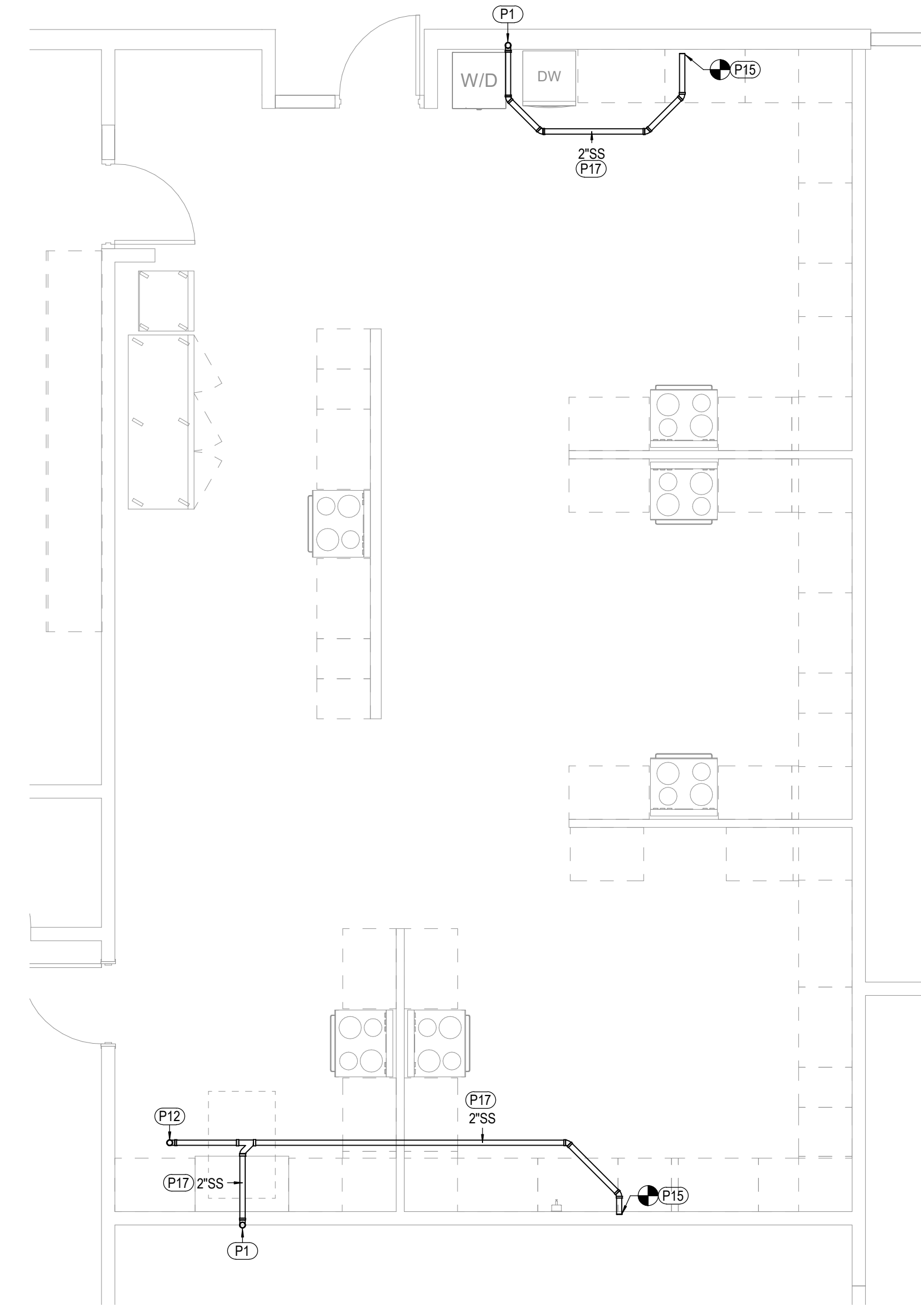

2 PLUMBING PLAN - UNDERFLOOR
SCALE: 1/4" = 1'-0"

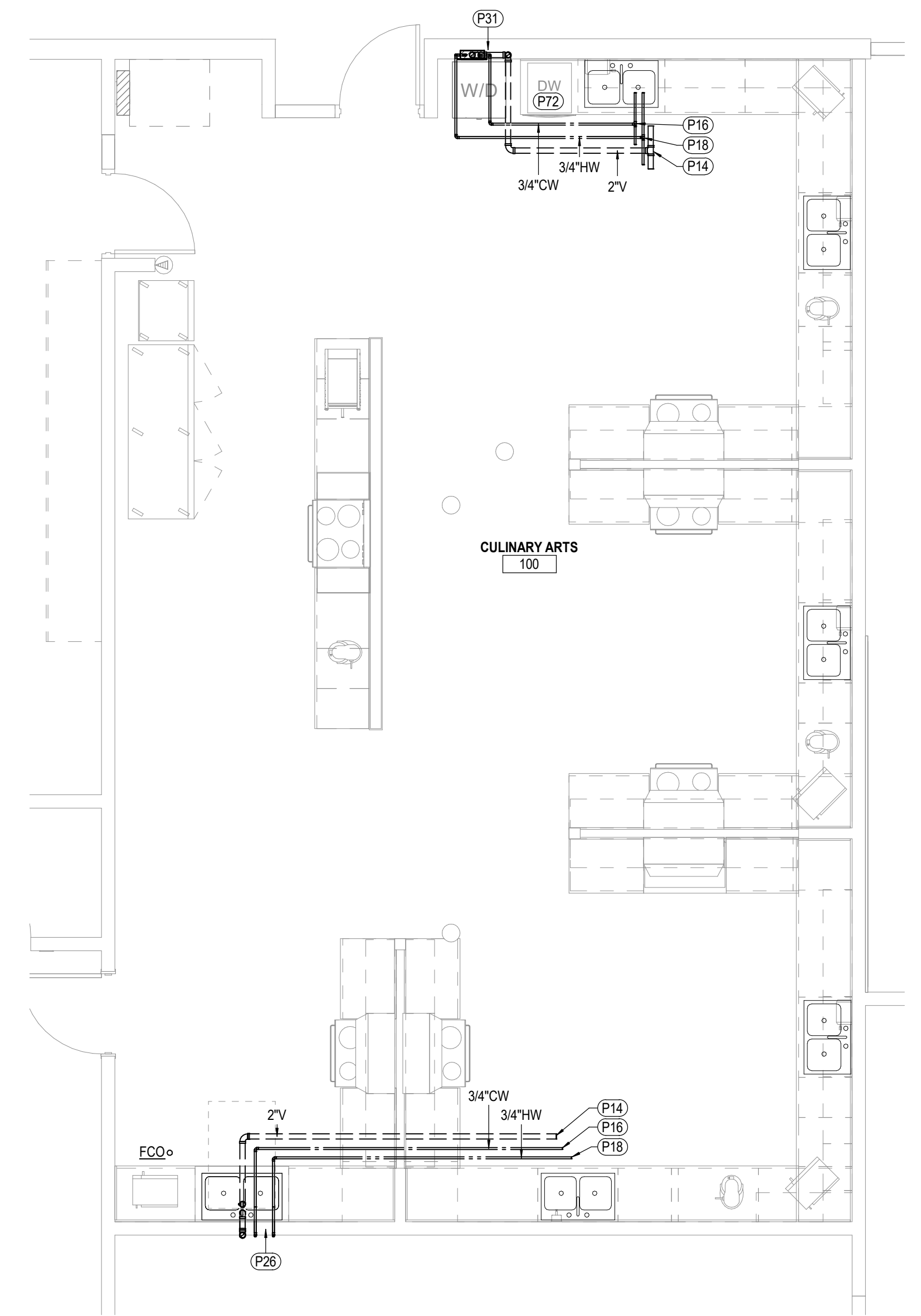

3 PLUMBING PLAN
SCALE: 1/4" = 1'-0"

- GENERAL NOTES - PLUMBING PLAN**
1. THE CONTRACTOR SHALL COMPLY WITH ALL AUTHORITIES HAVING JURISDICTION.
 2. ALL FINAL CONNECTIONS TO FIXTURES AND EQUIPMENT SHALL BE MADE BY THE PLUMBING CONTRACTOR.
 3. ALL PLUMBING PIPING SHALL BE COORDINATED WITH ALL OTHER TRADES PRIOR TO ANY INSTALLATION OF ALL PLUMBING FIXTURES AND EQUIPMENT BY THE PLUMBING CONTRACTOR.
 4. ALL FLOOR DRAINS AND FLOOR SINKS SHOWN ON THIS DRAWING SHALL BE COORDINATED WITH ALL OTHER TRADES PRIOR TO INSTALLATION.
 5. REFER TO ARCHITECTURAL DRAWING FOR EXACT LOCATIONS OF FIXTURES, EQUIPMENT, ETC. DO NOT SCALE FROM PLUMBING DRAWINGS.
 6. ALL WALL CLEAN-OUTS SHALL BE ACCESSIBLE BY AN ACCESS PANEL.
 7. PROVIDE A DOUBLE EXTERIOR CLEAN-OUT (DFCO) ON ALL SANITARY LINES EXITING THE BUILDING.
 8. ALL FLOOR DRAINS AND FLOOR SINKS SHALL BE PROVIDED WITH A TRAP PRIMER.
 9. FIXTURES DESIGNATED AS ADA ACCESSIBLE BY ARCHITECT SHALL BE INSTALLED AT ADA ACCESSIBLE HEIGHT PER ARCHITECTURAL DETAILS.
 10. ALL DOMESTIC COLD AND HOT WATER TAKE-OFFS SHALL HAVE AN ISOLATION SHUT-OFF VALVE.
 11. FLOOR DRAINS AND FLOOR SINKS IN MECHANICAL ROOMS SHALL BE SET NOT LESS THAN 6" FROM HOUSEKEEPING PADS. RE: MECHANICAL DRAWINGS. DO NOT PLACE ON, OR IN, HOUSEKEEPING PAD, OR UNDERNEATH EQUIPMENT.
 12. CONTRACTOR SHALL DEWATER ANY AREA AT OR BELOW GRADE PRIOR TO SETTING EQUIPMENT.
 13. CONTRACTOR SHALL PLACE A TRAP PRIMER, TP-1, AND A HOSE BIBB, HB-2, IN ALL MECHANICAL ROOMS.
 14. PROVIDE A HOSE-BIBB WITH WHEEL HANDLE IN ALL MECHANICAL ROOMS, HB-2.
 15. ANY AND ALL WATER PIPING EXPOSED TO OUTSIDE ELEMENTS SHALL BE INSULATED AND HEAT TRACED TO PREVENT FREEZING.
 16. ALL SANITARY 3" OR ABOVE SHALL BE INSPECTED BY A CAMERA PRIOR TO SUBSTANTIAL COMPLETION.

- KEYED NOTES - PLUMBING PLAN**
- P1 2" WASTE PIPING DOWN FROM FLOOR ABOVE.
 - P12 4" WASTE PIPING DOWN FROM FLOOR CLEAN OUT ABOVE.
 - P14 CONNECT NEW VENT PIPING TO EXISTING VENT PIPING OVERHEAD IN THIS VICINITY. SIZE AS NOTED. CONTRACTOR TO FIELD VERIFY LOCATION OF EXISTING VENT PIPING PRIOR TO ANY CONSTRUCTION.
 - P15 CONNECT NEW WASTE PIPING TO EXISTING WASTE PIPING IN THIS VICINITY. SIZE AS NOTED. CONTRACTOR TO FIELD VERIFY LOCATION OF EXISTING WASTE PIPING PRIOR TO ANY CONSTRUCTION.
 - P16 CONNECT NEW COLD WATER PIPING TO EXISTING COLD PIPING IN THIS VICINITY. SIZE AS NOTED. CONTRACTOR TO FIELD VERIFY EXISTING LOCATION OF COLD PIPING PRIOR TO ANY CONSTRUCTION.
 - P17 SAW-CUT EXISTING SLAB AS INDICATED ON PLAN. REFER TO STRUCTURAL DRAWINGS FOR PATCHING THE FLOOR AND ARCHITECTURAL DRAWINGS FOR FLOOR FINISHES.
 - P18 CONNECT NEW HOT WATER PIPING TO EXISTING HOT PIPING IN THIS VICINITY. SIZE AS NOTED. CONTRACTOR TO FIELD VERIFY EXISTING LOCATION OF HOT PIPING PRIOR TO ANY CONSTRUCTION.
 - P26 3/4" COLD WATER, 3/4" HOT WATER DOWN AND 2" VENT UP.
 - P31 3/4" COLD WATER AND 3/4" HOT WATER DOWN TO WASHING MACHINE WALL BOX.



ARCHITECT PBK Architects, Inc.
SAN ANTONIO
601 N.W. Loop 410, Suite 400
San Antonio, TX 78216
210-829-0123 P
210-829-0578 F
TX Firm: BS-1688



MCSID - MISSION HS CULINARY ARTS
 1802 CLEO DAWSON ST
 MISSION, TX 78572
 ISSUE FOR CONSTRUCTION

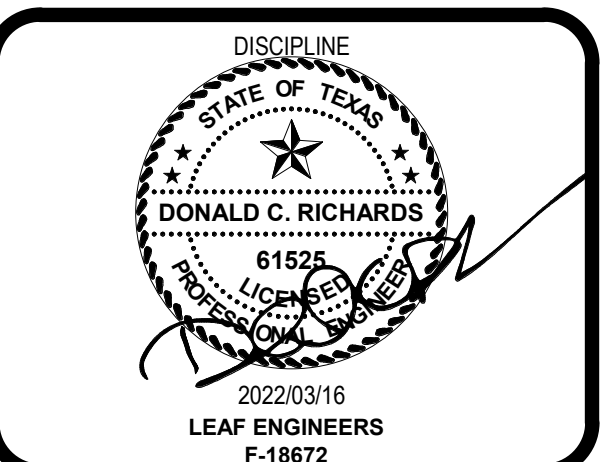
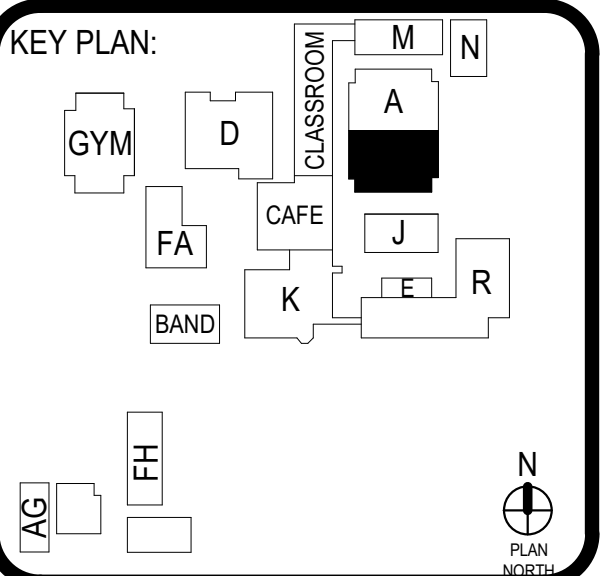

CLIENT		MCSID
DATE	2022/03/16	PROJECT NUMBER
		P2132600AR
DRAWING HISTORY		
No.	Description	Date

ISSUE FOR CONSTRUCTION
BUILDING NUMBER

PLUMBING PLAN
P2.01

LEAF ENGINEERS
601 N.W. LOOP 410, SUITE 400
SAN ANTONIO, TX 78216
210-638-7200
TX Firm: F-18672

SUBJECT: Approval to Accept Final Design for the Culinary Arts for Veterans Memorial High School – PBK Architects

PRESENTER: Ricardo Rivera, Assistant Superintendent for Operations

BACKGROUND INFORMATION

The CTE program and Veterans Memorial High School currently have a culinary arts lab. As per a field inspection at VMHS the culinary lab is requiring possible renovations to be in code compliance. Areas of note are the current vent/hood suppression systems.

Administration will use competitive sealed proposals (CSP’s) as the procurement method as approved by the Board of Trustees in the February 2021 Board of Trustees meeting. This method was approved as the primary default method for projects.

At the Regular Board of Trustees meeting held on August 11, 2021 the Board approved the project, proposed budget and utilizing the on-call professional services for the Culinary Arts Laboratory at Veterans Memorial High School Project – PBK Architects. PBK Architects estimated project cost is \$10,000.00.

At the Regular Board of Trustees held on February 09, 2022, the Board approved Schematic Design for the Culinary Arts Laboratory at Veterans Memorial High School Project – PBK Architects.

Schematic Design:

Rough sketches that develop a feasible conceptual design of the project.

Construction Documents:

Communicating the design intent through further refinement of the written and graphic representation of all building materials, components and equipment that can be quantified and useful to contractors.

ADMINISTRATIVE CONSIDERATIONS

PBK Architect has continued to meet with MCISD Staff and Administration on schematic designs, thus administration will be presenting Approval to Accept Final Design for the Culinary Arts Laboratory at Veterans Memorial High School Project – PBK Architects. Designs have been reviewed and approved by staff. When approved Administration will advertise for proposals.

At the Board Work Shop Mr. David Iglesias, PBK Architects advised Administration and the Board of Trustees that additional vent hood systems above every student cooking station (6) and above the instructor cooking station that was not initially anticipated would be required thus the project budget would be exceeded.

FUNDING SOURCE

Local Fund

Est. Project Budget:	\$10,000.00
Project Contingency 20%:	\$ 2,000.00
Est. Professional Services 12%:	\$ 1,200.00
Est. Total Project Cost:	\$13,200.00

RECOMMENDATION

This agenda item was presented at the Board of Trustees Workshop on Wednesday, April 06, 2022.

Administration is presenting Approval to Accept Final Design for the Culinary Arts for Veterans Memorial High School – PBK Architects

EXHIBIT:

Final Designs

CONTACT PERSONS

Ricardo Rivera, Assistant Superintendent for Operations

Adrian Hernandez, Coordinator for Project & Energy Management

MCISD VETERANS MEMORIAL HIGH SCHOOL CULINARY ARTS CLASSROOM RENOVATION



BOARD MEMBERS

JERRY ZAMORA - PRESIDENT
 VERONICA "BETTY" R. MENDOZA - VICE PRESIDENT
 ROY VELA - SECRETARY
 PETRA B. RAMIREZ - BOARD MEMBER
 MINNIE R. RODGERS - BOARD MEMBER
 JUAN M. GONZALEZ - BOARD MEMBER
 IRIS IGLESIAS - BOARD MEMBER

DR. CAROLINA G. PEREZ - SUPERINTENDENT OF SCHOOLS

SHEET INDEX

ARCHITECTURAL
 A-101 FLOOR PLAN & RCP
 MECHANICAL
 MD2.01 MECHANICAL DEMOLITION
 MZ.01 MECHANICAL PLAN
 ELECTRICAL
 E2.01 ELECTRICAL POWER PLAN



ARCHITECT PBK Architects, Inc.
 HOUSTON
 11 Greenway Plaza, 22nd Floor
 Houston, TX 77046
 713-965-0668 P
 713-961-4571 F
 TX Firm: BS-1608



MCISD VETERANS HS CULINARY ARTS

700 E MILE 2 RD
 MISSION, TX 78574
 CONSTRUCTION DOCUMENTS

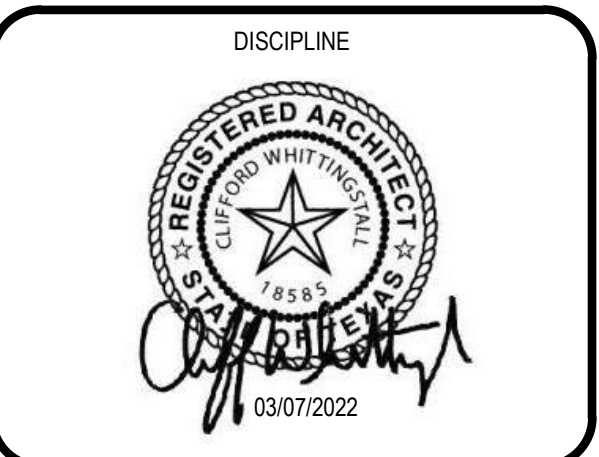

CLIENT		
DATE	PROJECT NUMBER	
YYYY/MM/DD	[Project Number]	
DRAWING HISTORY		
No.	Description	Date

CONSTRUCTION DOCUMENTS
 BUILDING NUMBER

COVER SHEET

G-000

GENERAL ARCH PLAN NOTES

- DO NOT SCALE DRAWINGS. WRITTEN DIMENSIONS TAKE PRECEDENCE. CONTACT ARCH IF CLARIFICATION IS NECESSARY IN ORDER TO DETERMINE THE INTENT OF THE CONTRACT DOCUMENTS.
- DRAWINGS NOTED AS "T.S." OR "NTS" ARE NOT TO SCALE.
- FIELD VERIFY ALL DIMENSIONS AND EXISTING CONDITIONS BEFORE COMMENCING WORK. NOTIFY ARCH. OF ANY DISCREPANCIES PRIOR TO PROCEEDING WITH AFFECTED WORK.
- NOTES OR DIMENSIONS NOTED AS "TYPICAL" OR "TYP." OR "TYP." SHALL APPLY TO CONDITIONS THAT ARE THE SAME OR SIMILAR.
- DIMENSIONS NOTED AS "FIELD VERIFY" OR "V.F." OR "V.F." SHALL BE MEASURED AND CONFIRMED AT THE PROJECT SITE BY THE CONTRACTOR AND REVIEWED WITH THE ARCH. BEFORE INCORPORATING INTO THE WORK.
- DIMENSIONS NOTED AS "CLEAR" OR "CLEAR INSIDE" REQUIRE SPECIFIC COORDINATION AMONG DISCIPLINES AND/OR MANUFACTURERS.
- ALIGN FINISHED FACE OF WALLS WHERE WALL PARTITIONS OF DIFFERING THICKNESS ABUT AND OR ADJOIN IN THE SAME PLANE.
- PROVIDE AND INSTALL CONT. REVEAL TRIM AT JOINT WHERE GYPSUM BOARD WALL PARTITIONS ABUT AND OR ADJOIN MASONRY WALL PARTITIONS IN THE SAME PLANE.
- ALL FLOOR SLOPES TO FLOOR DRAINS SHALL NOT EXCEED 1/8".
- PROVIDE AND INSTALL SELF-LEVELING UNDERLAYMENT WHERE UNEVEN FLOOR SLAB EXISTS PRIOR TO INSTALLATION OF FLOOR FINISHES.
- ALL REQUIRED ACCESSIBLE CLEARANCES FOR ALL ITEMS, INCLUDING BUT NOT LIMITED TO ALL COUNTER TOPS, ALL PLUMBING FIXTURES, ALL DRINKING FOUNTAINS, ALL ELECTRIC WATER COOLERS, ALL LAVATORIES, ALL URINALS, ALL TOILETS SHALL BE STRICTLY ENFORCED.
- REFER TO OTHER DISCIPLINE DOCUMENTS FOR ADDITIONAL SCOPE OF WORK.

GENERAL CEILING PLAN NOTES

- REFER TO AND COORD. WITH ROOM FINISH SCHEDULES FOR SPECIFIC CEILING TYPES.
- ALL SCHEDULED CEILING HEIGHTS ARE FROM THE MAIN FLOOR LEVEL WITHIN THE ROOM AND OR SPACE. AND ARE NOT FROM AN ELEVATED FLOOR LEVEL, AND ARE NOT FROM A RECESSED FLOOR LEVEL.
- NO FIRE SPRINKLER HEADS ARE SHOWN ON ARCH. CEILING PLANS. ALL SPRINKLER HEADS SHALL BE CENTERED WITHIN CEILING TILES U.N.C.
- ONLY CEILING MOUNTED FIXTURES AND EQUIP. IS SHOWN ON ARCH. CEILING PLANS. REFER TO INTERIOR ELEVATIONS FOR WALL MOUNTED FIXTURES. REFER TO MEPT DOCUMENTS FOR ADDITIONAL INFORMATION CONCERNING CEILING MOUNTED FIXTURES AND OR WALL MOUNTED FIXTURES.
- CEILING MOUNTED LIGHT FIXTURES ARE SHOWN FOR LOCATION PURPOSES ONLY. COORD. WITH ELEC. DOCUMENTS FOR LIGHT FIXTURE DESIGNATIONS.
- CEILING MOUNTED LIGHT FIXTURES WITHIN FIRE RATED CEILING ASSEMBLIES SHALL HAVE LIGHT FIXTURE PROTECTION AND BE TENTED OR OTHERWISE FIRE RATED TO MATCH CEILING ASSEMBLY FIRE RATING.
- VERIFY LOCATIONS OF ALL CEILING ACCESS PANELS WITH MEPT DOCUMENTS. COORD. LOCATIONS OF CEILING ACCESS PANELS WITH ARCH. PRIOR TO INSTALLATION. CEILING ACCESS PANEL FIRE RATINGS SHALL MATCH CEILING ASSEMBLY FIRE RATINGS.
- REFER TO WALL SECTIONS FOR WALL-CEILING INTERFACE.

KEYNOTES

- NEW COMMERCIAL VENT HOOD LOCATION
- NEW WALL MOUNTED CABINET TO CONCEAL FIRE SUPPRESSION SYSTEM
- EXISTING VENT HOOD TO BE REMOVED AND RETURNED TO OWNER.
- NEW RESIDENTIAL STYLE VENT HOOD
- NEW GUARDIAN MODEL G500-B LOCATION
- EXISTING ELECTRICAL PANEL
- EXISTING 2x2 CEILING GRID W/ EXISTING LIGHT FIXTURES.
- VENT HOOD LOCATION (RCP)

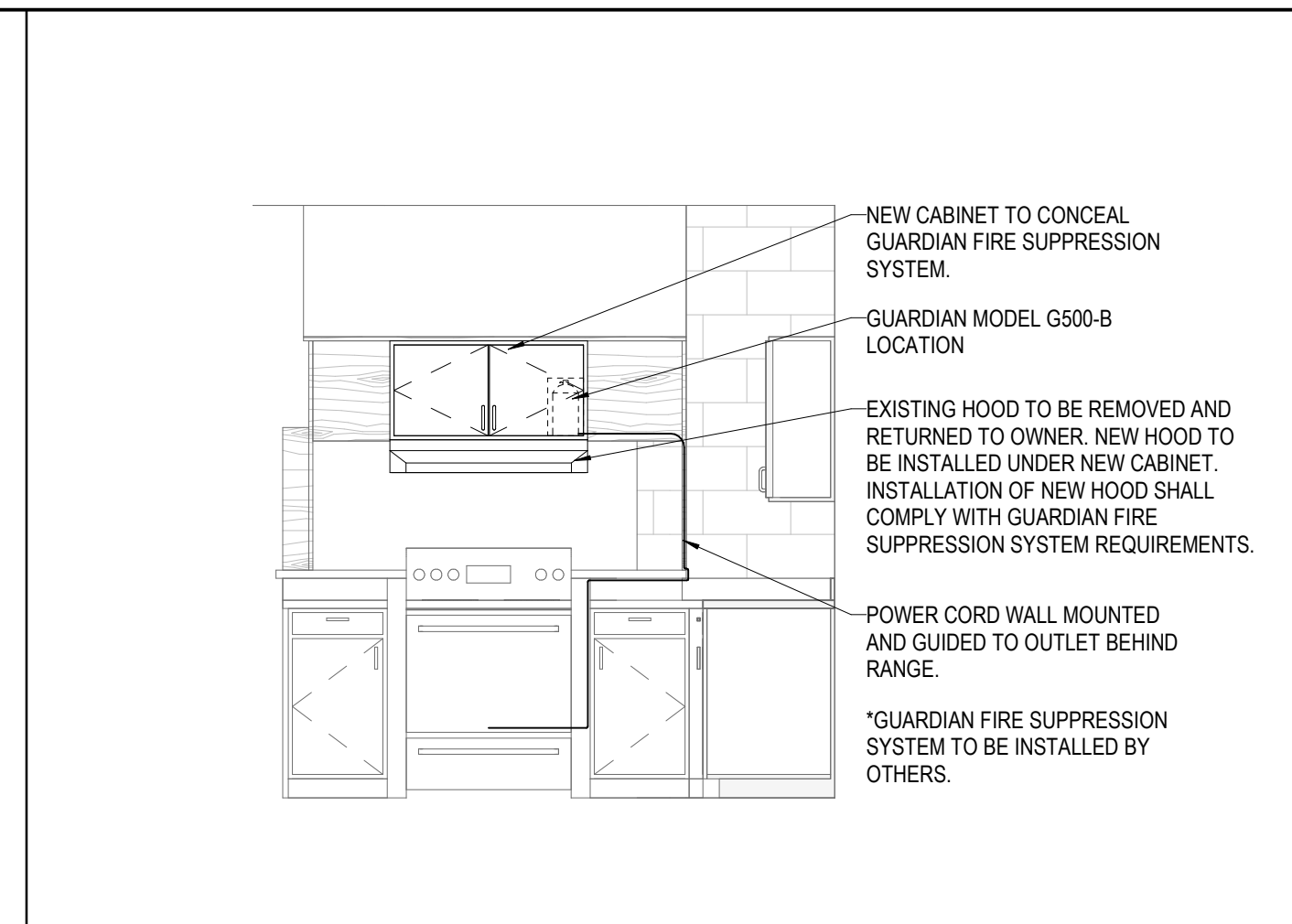

03 STUDENT STATION TYP.
3/8" = 1'-0"

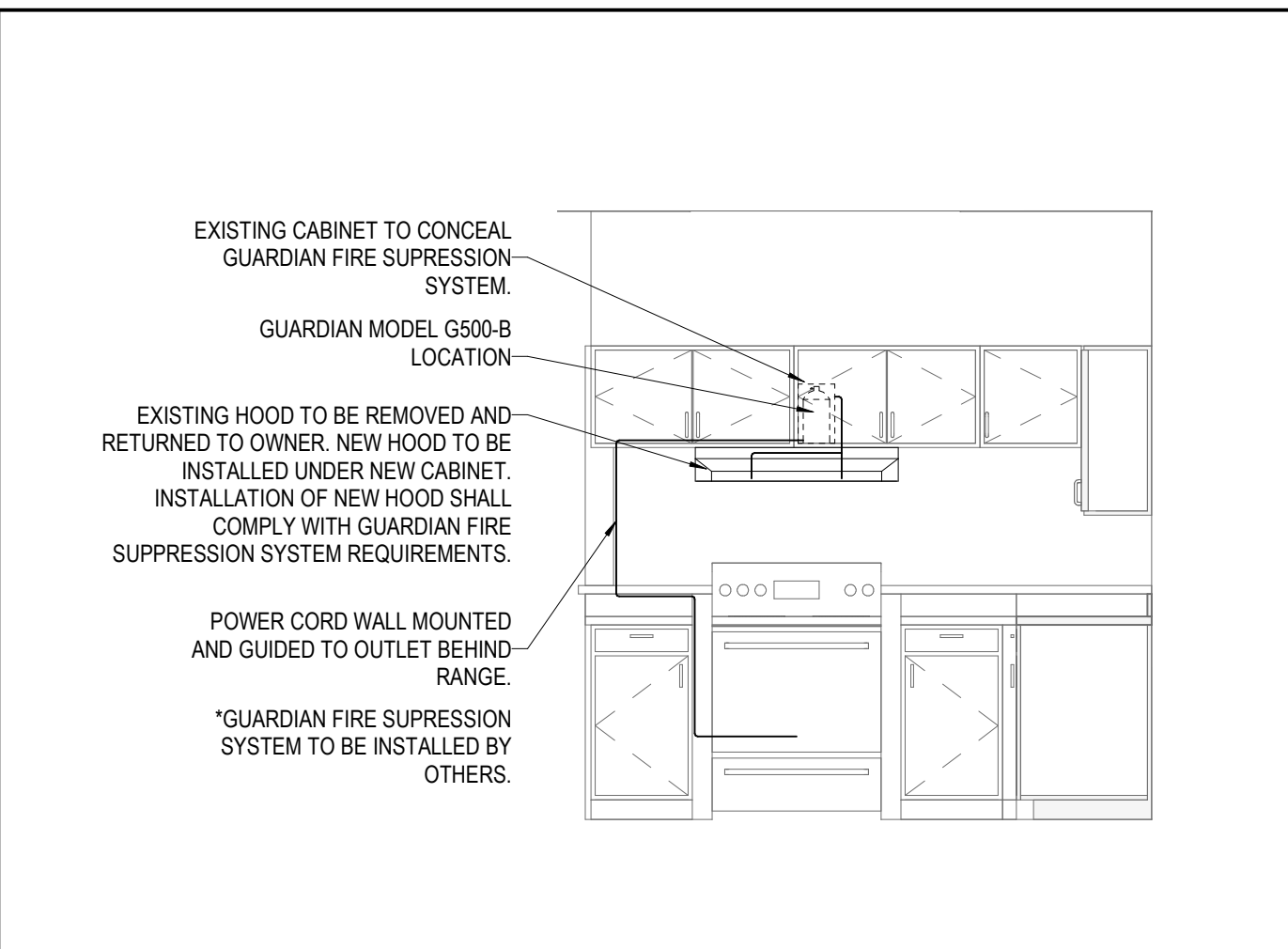

04 STUDENT STATION TYP.
3/8" = 1'-0"

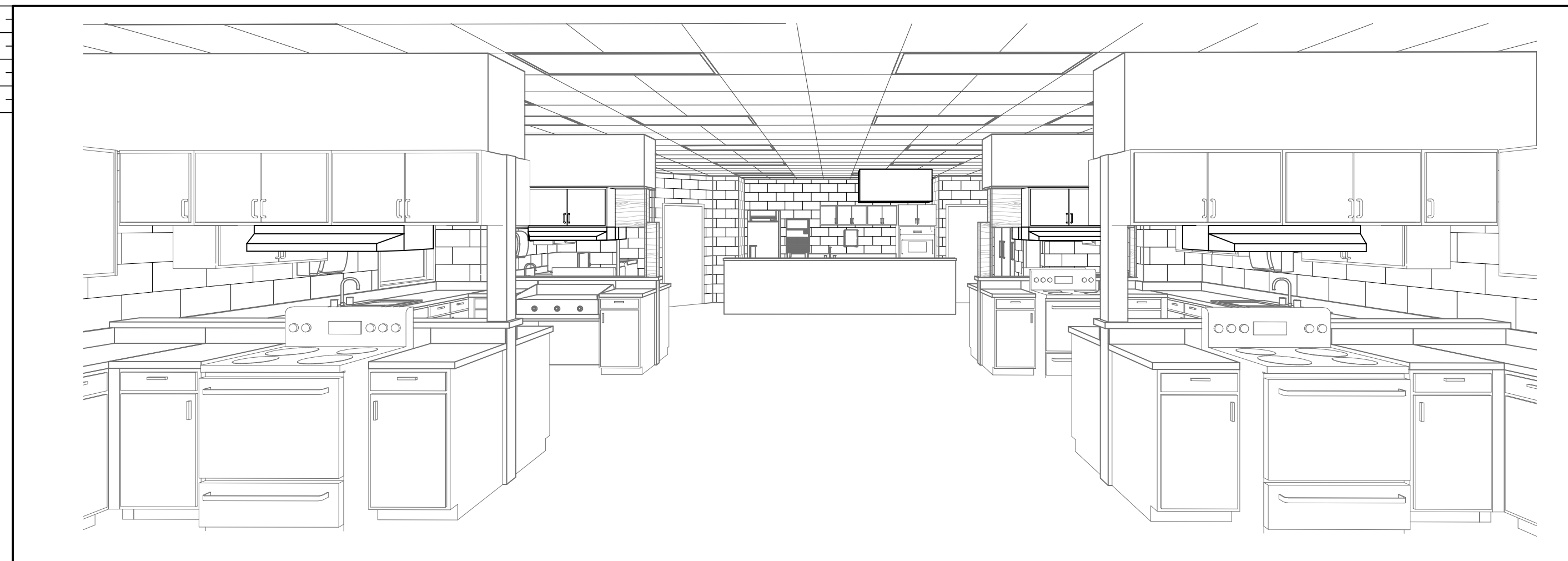

05 3D VIEW

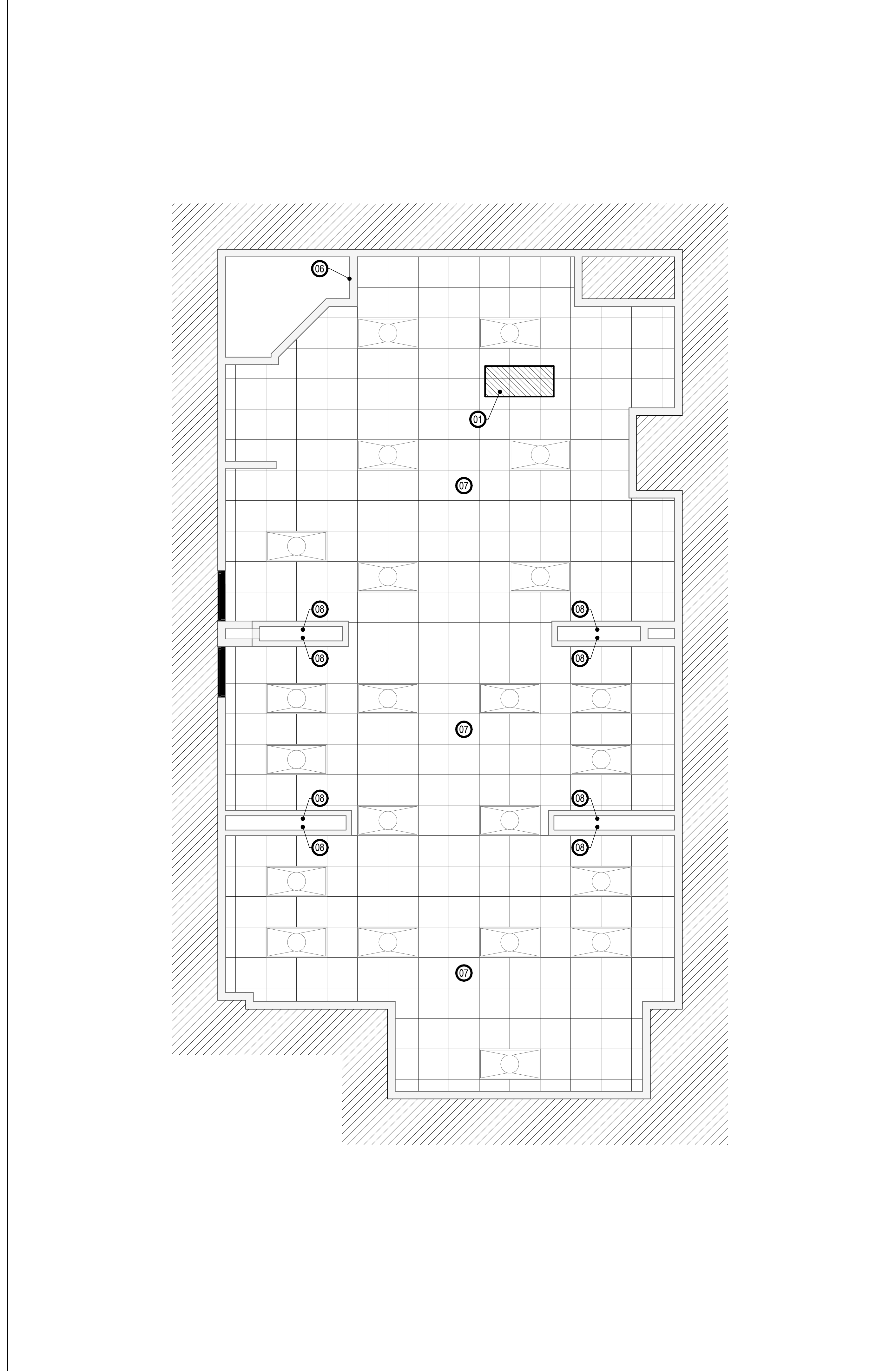

02 RCP - COMPOSITE
1/4" = 1'-0"

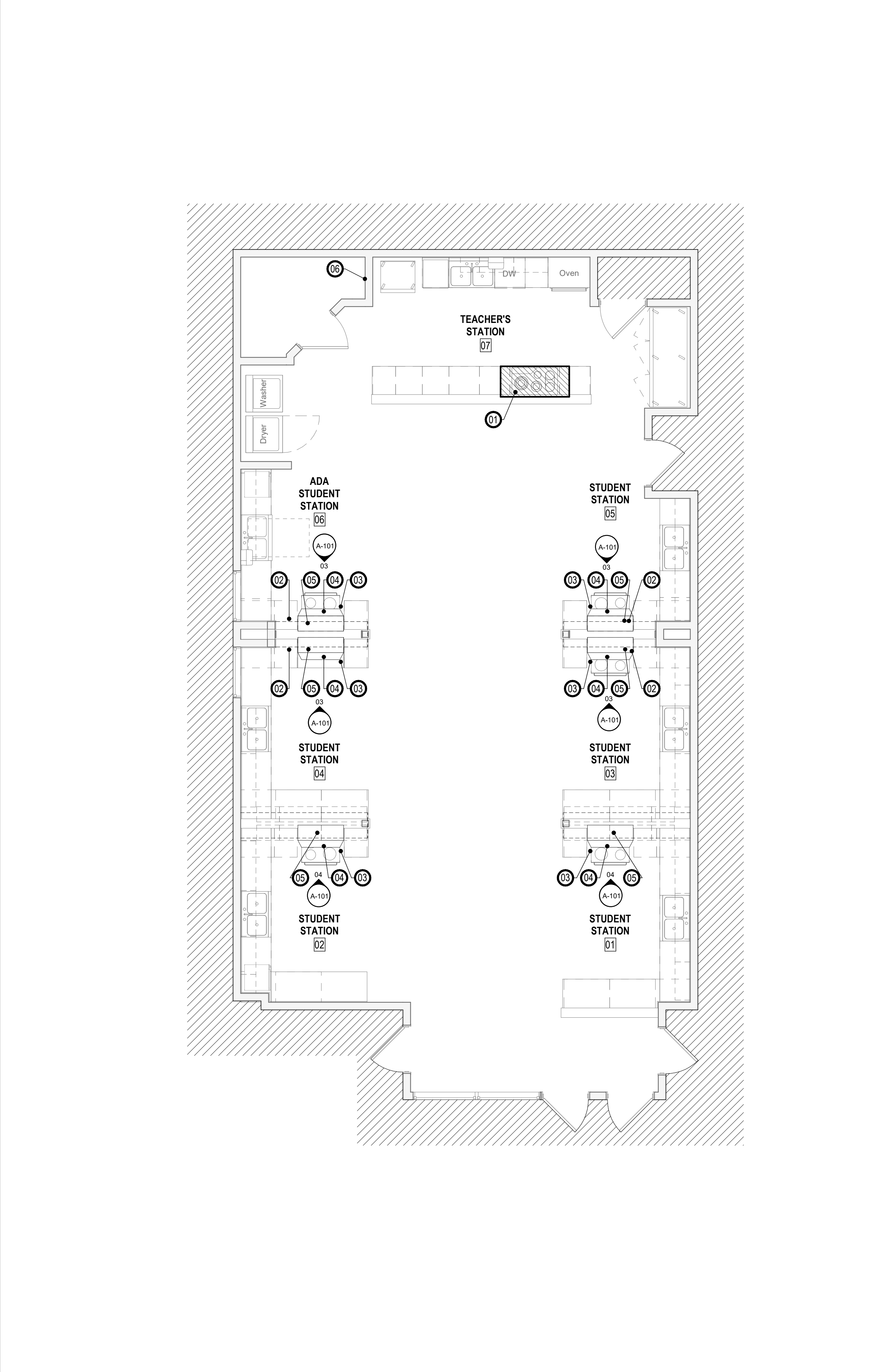

01 FLOOR PLAN
1/4" = 1'-0"

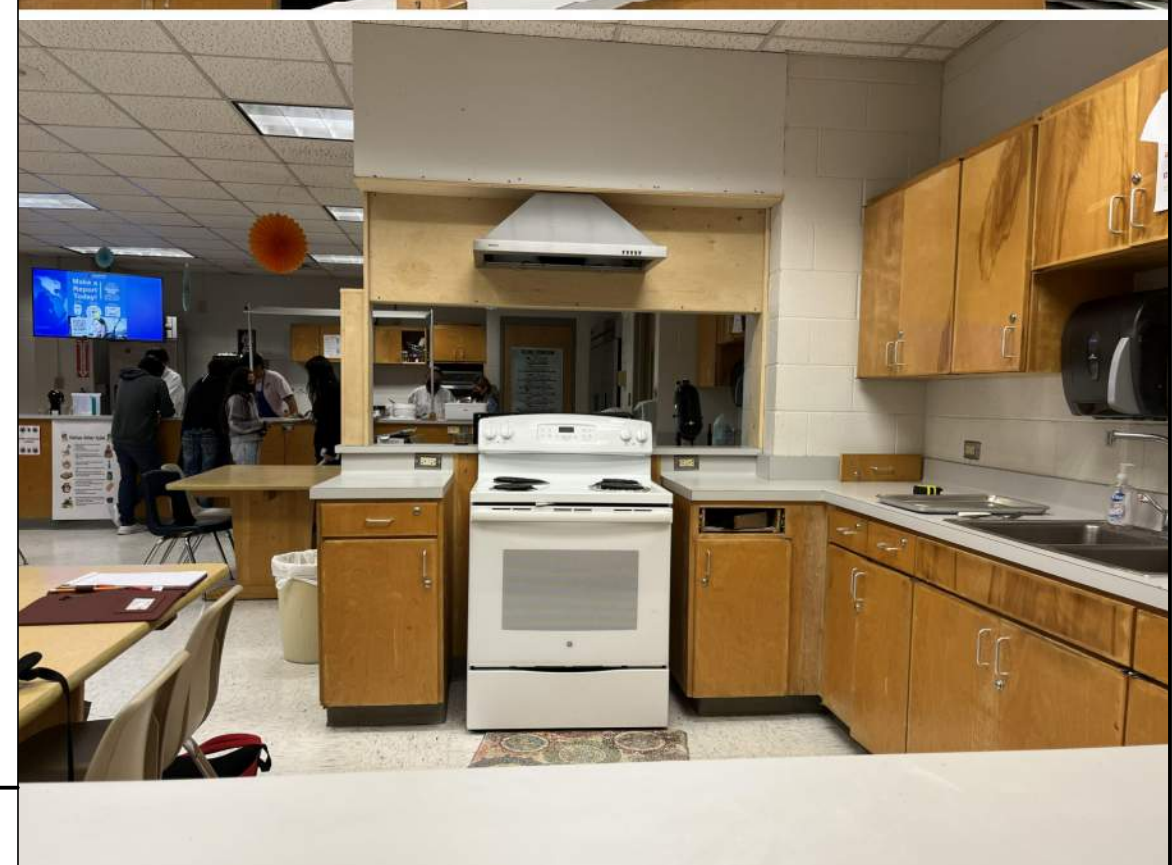

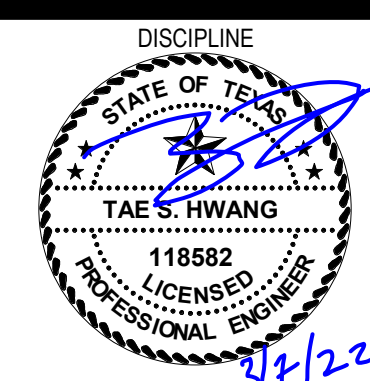

LEAF ENGINEERS
F-18672

**MECHANICAL
DEMOLITION**

MD2.01

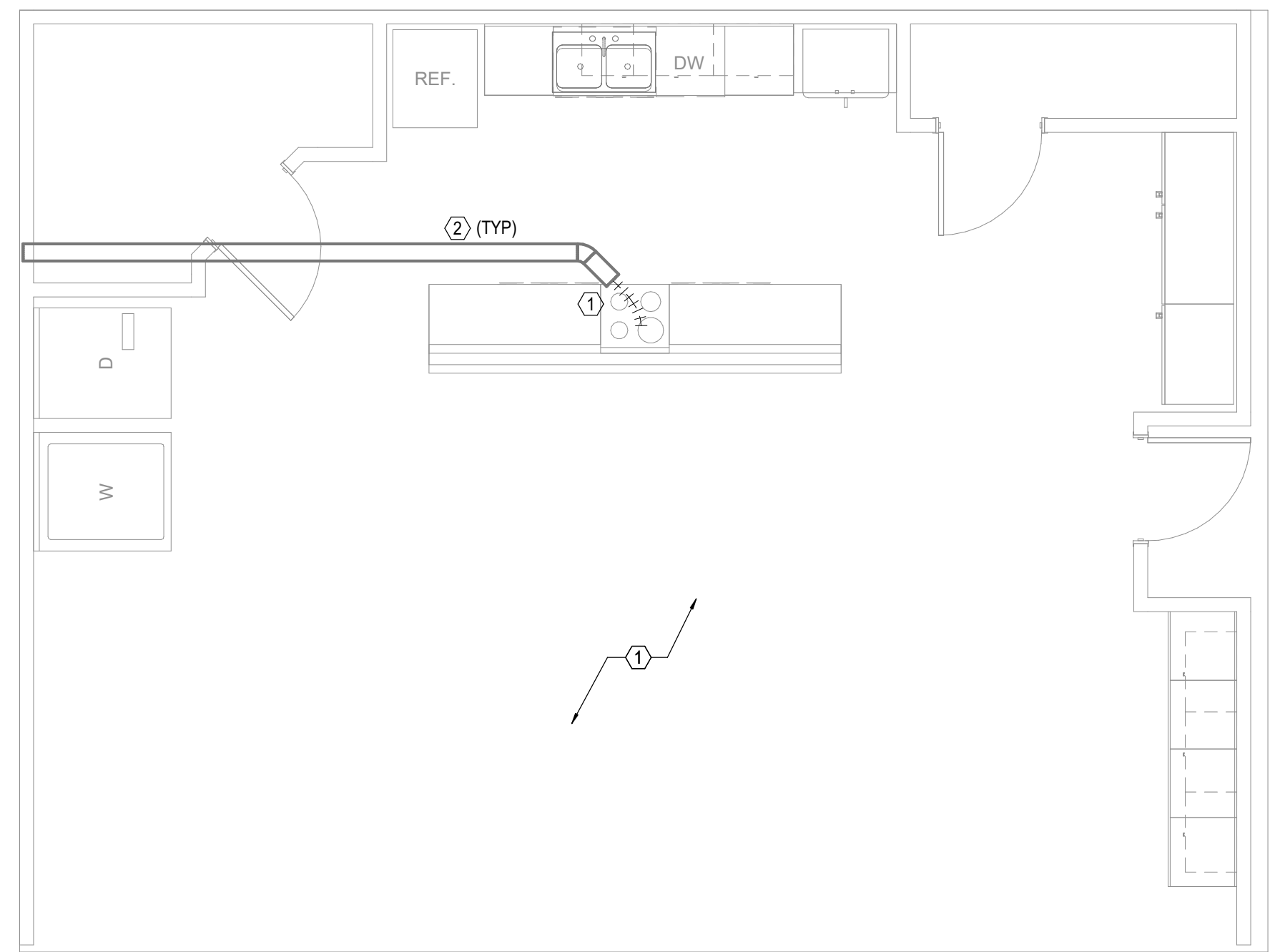

1 MECHANICAL PLAN - DEMOLITION
SCALE: 1/4" = 1'-0"

GENERAL NOTES - MECHANICAL PLAN

1. THE DRAWINGS ARE DIAGRAMMATIC AND INDICATE THE GENERAL LOCATION OF EQUIPMENT, DUCTS, AND GRILLES ETC. IT IS THE INTENT OF THESE DRAWINGS AND SPECIFICATIONS THAT COMPLETE MECHANICAL SYSTEMS BE FURNISHED, INSTALLED, TESTED AND READY FOR OPERATION WHETHER OR NOT EVERY ITEM OF EQUIPMENT, ACCESSORY, DEVICE, ETC. IS SHOWN. REFERENCE SHALL BE MADE TO THE FULL DRAWING PACKAGE INCLUDING ARCHITECTURAL, STRUCTURAL, ELECTRICAL, AND PLUMBING DRAWINGS FOR COORDINATION AND POTENTIAL CONFLICTS. THE MECHANICAL SUBCONTRACTOR SHALL, WITHOUT EXTRA CHARGE, MAKE REASONABLE MODIFICATIONS IN THE LAYOUT AS NEEDED TO PREVENT CONFLICTS WITH OTHER TRADES, OR FOR PROPER EXECUTION OF THE WORK. FIELD VERIFY ALL DIMENSIONS BEFORE FABRICATING DUCTWORK.
2. DO NOT SCALE DRAWINGS. VERIFY ALL DIMENSIONS AND CLEARANCES FROM ARCHITECTURAL, STRUCTURAL, SUBMITTALS, AND OTHER APPROPRIATE DRAWINGS OR PHYSICALLY AT SITE. REVIEW ALL DRAWINGS, INCLUDING THOSE OF OTHER TRADES.
3. COORDINATE ALL WORK WITH ALL OTHER TRADES PRIOR TO INSTALLATION TO PROVIDE CLEARANCES REQUIRED FOR OPERATION, MAINTENANCE, CODE COMPLIANCE, AND TO VERIFY NON-INTERFERENCE WITH OTHER WORK. DO NOT FABRICATE PRIOR TO VERIFICATION OF NECESSARY CLEARANCES FOR ALL TRADES. BRING ANY INTERFERENCES OR CONFLICTS TO THE ATTENTION OF THE ARCHITECT/ENGINEER BEFORE PROCEEDING WITH FABRICATION OR EQUIPMENT ORDERS.
4. REVIEW SPACE REQUIREMENTS OF EQUIPMENT SPECIFIED OR SUBSTITUTED AND MAKE REASONABLE ACCOMMODATIONS IN LAYOUT AND POSITIONING TO PROVIDE PROPER ACCESS.
5. ANY CHANGES REQUIRED TO ELIMINATE CONFLICTS OR THAT RESULT FROM A FAILURE TO COORDINATE SHALL BE MADE BY THE CONTRACTOR WITHOUT ADDITIONAL COST OR EXPENSE TO OTHERS.
6. EACH CONTRACTOR IS RESPONSIBLE FOR DAMAGE CAUSED BY THEIR ACTIONS TO WALLS, FLOORS, CEILINGS, AND ROOFS. THE CONTRACTOR WHOSE WORK CAUSES DAMAGE IS RESPONSIBLE FOR PATCHING TO MATCH ORIGINAL CONSTRUCTION, FIRE RATING, AND FINISH.
7. IN AREAS WITH DRYWALL CEILINGS COORDINATE LOCATIONS OF ACCESS PANELS WITH THE GC FOR ACCESS TO VALVES, DUCTWORK ACCESSORIES, DAMPERS, ETC. COORDINATE PANEL TYPE AND COLOR WITH ARCHITECT. NOTIFY THE GC OF THE REQUIRED ACCESS PANELS PRIOR TO BIDDING.
8. SEAL ALL FLOOR AND WALL PENETRATIONS AIRTIGHT WHERE CONDUITS, PIPING, AND DUCTS PENETRATE.
9. CAULK ALL PIPE AND DUCT PENETRATIONS OF FULL HEIGHT NON-FIRE RATED WALL, PARTITION, FLOOR, AND ROOF ASSEMBLIES. THIS IS ESSENTIAL TO PREVENT NOISE TRANSMISSION FROM ONE ROOM TO ANOTHER AND TO PROVIDE THE DESIRED NC LEVELS WITHIN ROOMS.
10. CONTRACTOR SHALL FIELD VERIFY ALL EXISTING CONDITIONS PRIOR TO THE START OF THE DEMOLITION PROCESS.

KEYED NOTES - MECHANICAL PLAN

- 1 REMOVE EXISTING FLEX DUCT FROM RANGE HOOD EXHAUST DUCT WITHIN SCOPE OF WORK.
- 2 EXISTING HOOD EXHAUST DUCTWORK. CONTRACTOR SHALL VERIFY THE CONSTRUCTION OF THE DUCTWORK PRIOR TO ANY WORK BEING PERFORMED TO ENSURE THAT THE DUCTWORK MEETS THE REQUIREMENTS SET FORTH IN THE INTERNATIONAL MECHANICAL CODE SECTION 505. IF THE DUCTWORK DEVIATES FROM THE REQUIREMENTS, THEN THE DUCTWORK SHALL BE REPLACED WITH NEW OF THE SAME SIZE. IF DUCTWORK IS ACCEPTABLE, ANY BLOCKAGES THAT EXIST SHALL BE CLEARED TO PROVIDE A FULLY FUNCTIONAL SYSTEM. TYPICAL OF ALL EXHAUST HOOD DUCTWORK WITHIN SCOPE OF WORK.

GENERAL NOTES - MECHANICAL PLAN

1. THE DRAWINGS ARE DIAGRAMMATIC AND INDICATE THE GENERAL LOCATION OF EQUIPMENT, DUCTS, AND GRILLES ETC. IT IS THE INTENT OF THESE DRAWINGS AND SPECIFICATIONS THAT COMPLETE MECHANICAL SYSTEMS BE FURNISHED, INSTALLED, TESTED AND READY FOR OPERATION WHETHER OR NOT EVERY ITEM OF EQUIPMENT, ACCESSORY, DEVICE, ETC. IS SHOWN. REFERENCE SHALL BE MADE TO THE FULL DRAWING PACKAGE INCLUDING ARCHITECTURAL, STRUCTURAL, ELECTRICAL, AND PLUMBING DRAWINGS FOR COORDINATION AND POTENTIAL CONFLICTS. THE MECHANICAL SUBCONTRACTOR SHALL, WITHOUT EXTRA CHARGE, MAKE REASONABLE MODIFICATIONS IN THE LAYOUT AS NEEDED TO PREVENT CONFLICTS WITH OTHER TRADES, OR FOR PROPER EXECUTION OF THE WORK. FIELD VERIFY ALL DIMENSIONS BEFORE FABRICATING DUCTWORK.
2. DO NOT SCALE DRAWINGS. VERIFY ALL DIMENSIONS AND CLEARANCES FROM ARCHITECTURAL, STRUCTURAL, SUBMITTALS, AND OTHER APPROPRIATE DRAWINGS OR PHYSICALLY AT SITE. REVIEW ALL DRAWINGS, INCLUDING THOSE OF OTHER TRADES.
3. COORDINATE ALL WORK WITH ALL OTHER TRADES PRIOR TO INSTALLATION TO PROVIDE CLEARANCES REQUIRED FOR OPERATION, MAINTENANCE, CODE COMPLIANCE, AND TO VERIFY NON-INTERFERENCE WITH OTHER WORK. DO NOT FABRICATE PRIOR TO VERIFICATION OF NECESSARY CLEARANCES FOR ALL TRADES. BRING ANY INTERFERENCES OR CONFLICTS TO THE ATTENTION OF THE ARCHITECT/ENGINEER BEFORE PROCEEDING WITH FABRICATION OR EQUIPMENT ORDERS.
4. REVIEW SPACE REQUIREMENTS OF EQUIPMENT SPECIFIED OR SUBSTITUTED AND MAKE REASONABLE ACCOMMODATIONS IN LAYOUT AND POSITIONING TO PROVIDE PROPER ACCESS.
5. ANY CHANGES REQUIRED TO ELIMINATE CONFLICTS OR THAT RESULT FROM A FAILURE TO COORDINATE SHALL BE MADE BY THE CONTRACTOR WITHOUT ADDITIONAL COST OR EXPENSE TO OTHERS.
6. EACH CONTRACTOR IS RESPONSIBLE FOR DAMAGE CAUSED BY THEIR ACTIONS TO WALLS, FLOORS, CEILINGS, AND ROOFS. THE CONTRACTOR WHOSE WORK CAUSES DAMAGE IS RESPONSIBLE FOR PATCHING TO MATCH ORIGINAL CONSTRUCTION, FIRE RATING, AND FINISH.
7. IN AREAS WITH DRYWALL CEILINGS COORDINATE LOCATIONS OF ACCESS PANELS WITH THE GC FOR ACCESS TO VALVES, DUCTWORK ACCESSORIES, DAMPERS, ETC. COORDINATE PANEL TYPE AND COLOR WITH ARCHITECT. NOTIFY THE GC OF THE REQUIRED ACCESS PANELS PRIOR TO BIDDING.
8. SEAL ALL FLOOR AND WALL PENETRATIONS AIRTIGHT WHERE CONDUITS, PIPING, AND DUCTS PENETRATE.
9. CAULK ALL PIPE AND DUCT PENETRATIONS OF FULL HEIGHT NON-FIRE RATED WALL, PARTITION, FLOOR, AND ROOF ASSEMBLIES. THIS IS ESSENTIAL TO PREVENT NOISE TRANSMISSION FROM ONE ROOM TO ANOTHER AND TO PROVIDE THE DESIRED NC LEVELS WITHIN ROOMS.
10. CONTRACTOR SHALL FIELD VERIFY ALL EXISTING CONDITIONS PRIOR TO THE START OF THE DEMOLITION PROCESS.

KEYED NOTES - MECHANICAL PLAN

1. NEW OWNER PROVIDED RANGE HOOD. CONTRACTOR SHALL VERIFY INSTALLATION REQUIREMENTS TO VERIFY THAT THE EXISTING DUCTWORK MEETS THE MANUFACTURER'S REQUIREMENTS.
2. PROVIDE AND INSTALL NEW SECTION OF HARD DUCT EXTENDING EXISTING TO THE NEW HOOD. CONNECT TO EXHAUST DUCT COLLAR ON THE HOOD. DUCTWORK CONSTRUCTION SHALL ADHERE TO THE REQUIREMENTS OF IMC 2015 SECTION 505. PROVIDE AND INSTALL BACKDRAFT DAMPER IF NOT PROVIDED WITH THE HOOD.

SYMBOL	DESCRIPTION	SYMBOL	DESCRIPTION
(CO)	CARBON DIOXIDE SENSOR		FLEXIBLE CONNECTION
(SD)	SMOKE DAMPER		MECHANICAL EQUIPMENT
(FS)	COMBINATION FIRE / SMOKE DAMPER		NEW DUCTWORK
(FD)	FIRE DAMPER		EXISTING DUCTWORK TO REMAIN
(H)	HUMIDISTAT		EXISTING DUCTWORK TO BE REMOVED
(T)	THERMOSTAT		CONNECTION TO EXISTING
(VD)	VOLUME DAMPER		
(S)	SMOKE DETECTOR		

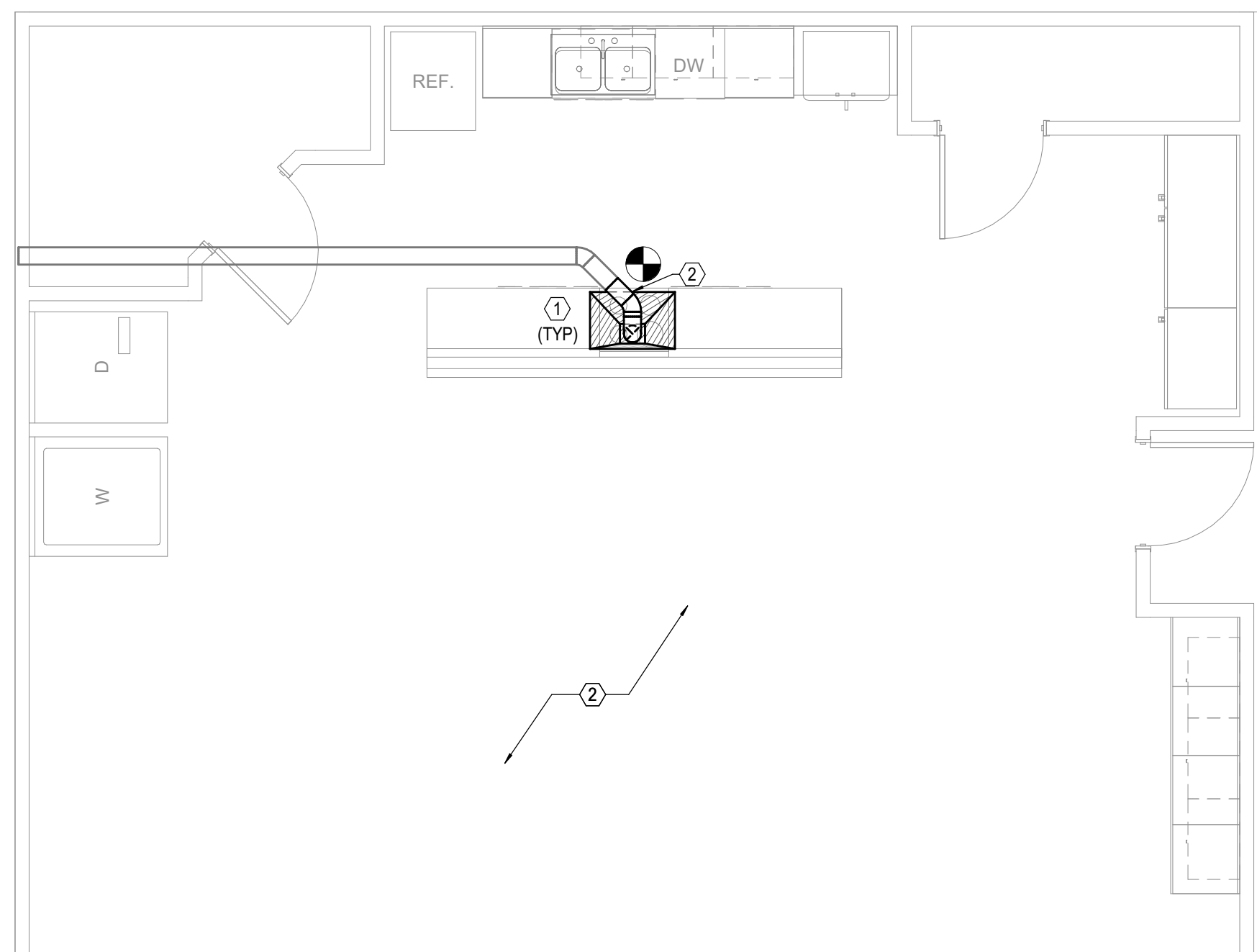

1 MECHANICAL PLAN - NEW WORK
SCALE: 1/4" = 1'-0"

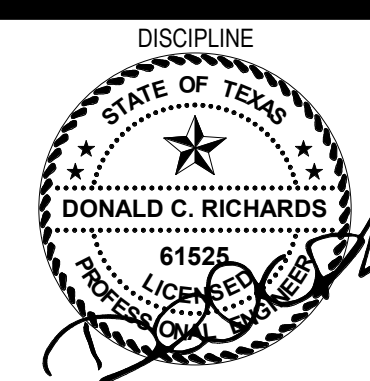

03/07/2022
 LEAF ENGINEERS
 F-18672

**ELECTRICAL POWER
 PLAN**

E2.01

GENERAL NOTES - POWER PLAN

- COORDINATE ROUGH-IN LOCATION OF DEVICES WITH ARCHITECTURAL ELEVATIONS, DETAILS AND PLANS. INSTALL DEVICE BOXES FLUSH WITH FINISHED SURFACE.
- INSTALL A DEDICATED NEUTRAL FOR EACH 120V OR 277V BRANCH CIRCUIT.

KEYED NOTES - POWER PLAN

- EP1 CONNECTION FOR EXHAUST HOOD WITH 2#12.#12GND,3/4"C. COORDINATE EXACT MOUNTING HEIGHT AND ROUGH-IN REQUIREMENTS WITH MANUFACTURER'S INSTALLATION INSTRUCTIONS.
- EP2 SERVE FROM NEW 120V, 20A CIRCUIT BREAKER IN EXISTING PANEL LSK.
- EP3 CONTRACTOR TO INSTALL NEW 20A1P CIRCUIT BREAKER IN EXISTING PANEL LSK, SPACE 26 FOR NEW EXHAUST HOOD. NEW BREAKER SHALL BE OF THE SAME MANUFACTURER AND COMPATIBLE WITH THE EXISTING PANEL. NEW BREAKER SHALL HAVE AN AIC RATING TO MATCH PANEL.

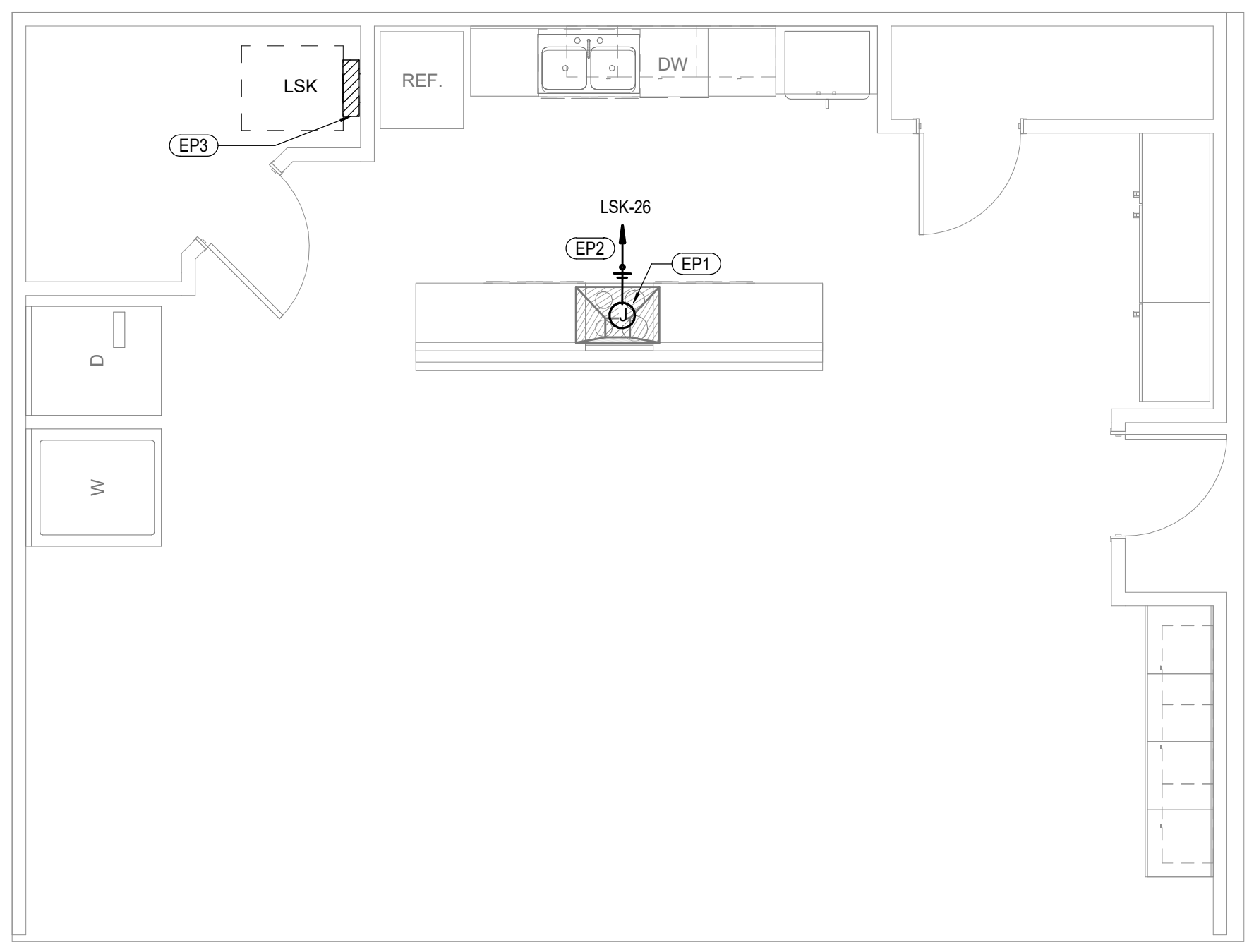

1 ELECTRICAL POWER PLAN
 SCALE: 1/4" = 1'-0"

SUBJECT: Approval to Accept Final Design for the Additional Animal Pens for the Agricultural Science Barns Project – PBK Architects

PRESENTER: Rick Rivera, Assistant Superintendent for Operations

BACKGROUND INFORMATION

In May of 2008, a successful construction bond election was concluded for a total amount of \$59,000,000.00. In August of 2008, the Texas Education Agency (TEA) approved the District's application for the Instructional Facilities Allotment (IFA) program.

During the district-wide needs assessment for the 2006 and the 2008 bond construction and renovation projects were identified and subsequently ranked by priority. The projects selected by this process were funded and completed. There continued to be a need district-wide for improvements that were not funded by either the 2006 or 2008 bonds.

On Saturday, March 24, 2012, a Facilities Committee Bond Workshop was held to consider projects utilizing the remaining funds from the proposed new elementary school, which no longer was to be built.

At the Facilities Committee meeting held on April 11, 2012, one of the projects discussed for possible Board recommendation was the renovation and construction of the Agricultural Science Facility.

At the Regular Board of Trustees meeting held on Wednesday, April 18, 2012, the Board approved PBK Architects for administrative construction services for the renovations at the Agricultural Science Facility. At this same meeting, the Board approved a total budget of \$700,000.00 for the renovations.

The new facility will provide additional holding pens for goats, sheep, pigs, hogs and steers with wash racks, sand pits, lighting and a parking area. If the budget allows a possible show arena, classroom, office, concession area, etc. may be built. The Agricultural Science Facility would be utilized by the districts agricultural and FFA programs.

At the Facilities Committee meeting held on Wednesday, December 05, 2012, PBK presented preliminary drawings of potential renovations and additions to the site along with preliminary drawings of a new MCISD driveway and parking area. Discussed at the meeting were possible budget constraints, particularly what the Agricultural instructors at both high schools are initially recommending. Possibly, only a driveway and parking area may be able to be constructed with the current budget.

At the Regular Board of Trustees meeting held on Wednesday, January 23, 2013 the Board considered and approved for PBK Architects for a master plan design assessment for the agricultural science facilities renovation project. At this same Board of Trustees meeting, the Board decided to proceed to only fund the driveway and parking area at this time.

At the Facilities Committee meeting held on May 07, 2014, Committee Members reviewed two options for a master plan for the Agricultural Science Facility. After numerous design meetings with the Agricultural Instructors from both MHS and VMHS,

PBK Architects presented a master plan. The master plan incorporated those recommended suggestions into two designs. One design is to construct one large facility to be shared by both schools. The second design is for individual facilities. The plan consists of individual hog, pig, goat, lamb and steer pens, with storage rooms, classrooms, concession stand, wash racks, arena, loading shoots and parking lots. In order to proceed with the project, the Board of Trustees must approve the construction project, approve an estimated total construction budget, approve the procurement method and select an architect for the full design, development and administration. The Facilities Committee tabled this project due to the probability that the master plan would be over budget.

Administration continued to meet with MHS and VMHS Agricultural Instructors along with PBK Architects on the master plan and have agreed to a conceptual preliminary design that will be suitable to both instructors and campuses. The next phase of this project is requesting consideration and approval for the construction of a new Agricultural Science Facility and a proposed budget.

At the Special Board of Trustees Meeting held on Wednesday, October 01, 2014, the Board approved the construction of a new Ag Facility and Budget.

At the Regular Board of Trustees Meeting held on Wednesday, March 11, 2015, the Board approved "Final" designs. PBK Architects will proceed to complete construction documents. The construction of the driveway and parking lot is under a separate budget and contract. Mr. Javier Hinojosa Civil Engineering is under contract for this portion of the work

At the Special Board of Trustees meeting held on Wednesday, August 26, 2015, the Board approved to enter into contract with D. Wilson Construction.

General Funds

Construction Budget:	\$2,750,000.00
Total Construction Budget:	\$3,500,000.00
Wilson Const. BAFO:	\$2,607,000.00

Project final completion: 08/20/2016

At the Regular Board of Trustees Meeting held on November 11, 2020, the Board was informed that discussions with the previous Administration were held concerning what to do with the old agricultural farm. Discussions centered on that the old farm was in bad shape structurally and aesthetically and needed to be torn down since we now had built a new facility for both campuses. Discussions then were held on trying to keep some of the structure, pour concrete flooring, install tables and make this into a picnic area. This did not occur and was not a priority project.

Recently, parents and students continue to use these old facilities. Upon inspecting the conditions and makeshift electrical and power installations we declared that this area was not safe and the maintenance department proceeded to disconnect all electrical power to these buildings due to a potential fire and electrical hazard.

The question has now been asked what are we to do with these old structures, thus this presentation to the Board of Trustees. Current pictures are attached to show the conditions of the buildings. A consideration is that the center structure be demolished due to its poor condition. With work and funding possibly the west and east structure

may be salvaged for a temporary holding pen(s) during livestock shows at the new facility. The other structure may possibly be converted into a picnic area. Work that would need to be done is: (not all inclusive)

- Demolition of at least one structure
- Removal of old electrical, plumbing and camera devices
- Sandblasting of the structures
- Preparing and painting of the structures
- Concrete flooring
- New installation of electrical, plumbing and camera/security systems
- Possible repairs of pens
- Civil work
- Does not include any roofing work

Pending: Administration recommends Consideration and Approval of Project and Proposed Budget for the Demolition of Old Agricultural Science Barns Project.

Due to the increasing number of animal science projects for both Mission High School and Veterans Memorial High School, the CTE department is requesting to increase the number of animal pens at the current facility. The plan is for current hog and goat/lamb pens to be split into two pens allowing additional project animals. This project will be a turn-key construction project to include the additional electrical outlets and water troughs needed. Due to the nature of the project design engineering will be required. PBK Architects was the original design team for the Agricultural Science Barn.

At the Regular Board of Trustees meeting held on August 11, 2021 the Board approved the project, proposed budget and utilizing the on-call professional services for the Additional Animal Pens for the Agricultural Science Barns Project – PBK Architects. PBK Architects estimated project cost is \$50,000.00

At the Regular Board of Trustees meeting held on February 09, 2022, the Board approved Schematic Design for the Additional Animal Pens for the Agricultural Science Barns Project – PBK Architects. Designs have been reviewed and approved by staff.

Schematic Design:

Rough sketches that develop a feasible conceptual design of the project.

Construction Documents:

Communicating the design intent through further refinement of the written and graphic representation of all building materials, components and equipment that can be quantified and useful to contractors.

ADMINISTRATIVE CONSIDERATIONS

PBK Architect has continued to meet with MCISD Staff and Administration on the designs, thus administration will be presenting Approval to Accept Final Design for the Additional Animal Pens for the Agricultural Science Barns Project – PBK Architects. Designs have been reviewed and approved by staff. When approved Administration will be ready to advertise for proposals.

Existing animal pens – 48 pens

Additional animal pens – 28 pens

Total animal pens: 76 pens

At the Board Work Shop Mr. David Iglesias, PBK Architects advised Administration and the Board of Trustees that each pen would have both water and electrical outlets. The current water bowl system is to be replaced with a “nipple” drinking water system that would be adjustable.

FUNDING SOURCE AND AMOUNT

Local Funds/CTE

Est. Project Budget:	\$50,000.00
Project Contingency 20%:	\$10,000.00
Est. Professional Services 12%:	<u>\$ 6,000.00</u>
Est. Total Project Cost:	\$66,000.00

RECOMMENDATION

This agenda item was presented at the Board of Trustees Workshop on Wednesday, April 06, 2022.

Administration is presenting Approval to Accept Final Design for the Additional Animal Pens for the Agricultural Science Barns Project – PBK Architects

EXHIBIT

Final Designs

CONTACT PERSONS

Rick Rivera, Assistant Superintendent for Operations

Adrian Hernandez, Coordinator for Project & Energy Management

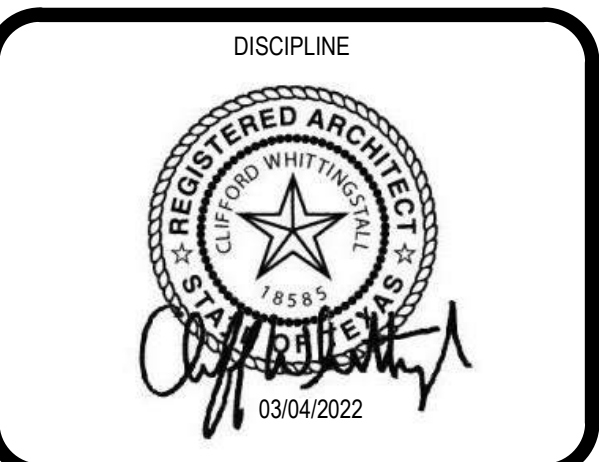
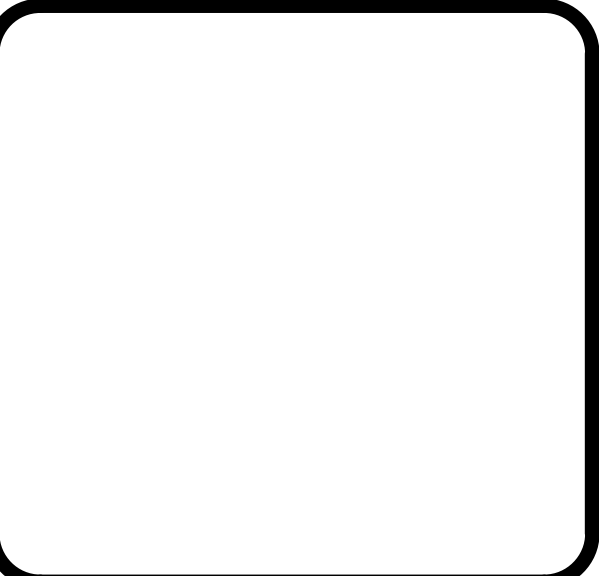

CLIENT		MISSION CISD
DATE	07/09/2015	PROJECT NUMBER
DRAWING HISTORY		P2132500AR
No.	Description	Date

ISSUE FOR CONSTRUCTION
 BUILDING NUMBER

COVER SHEET

G-000

JOSE "JOE" CORREA, JR MISSION CISD AG PENS

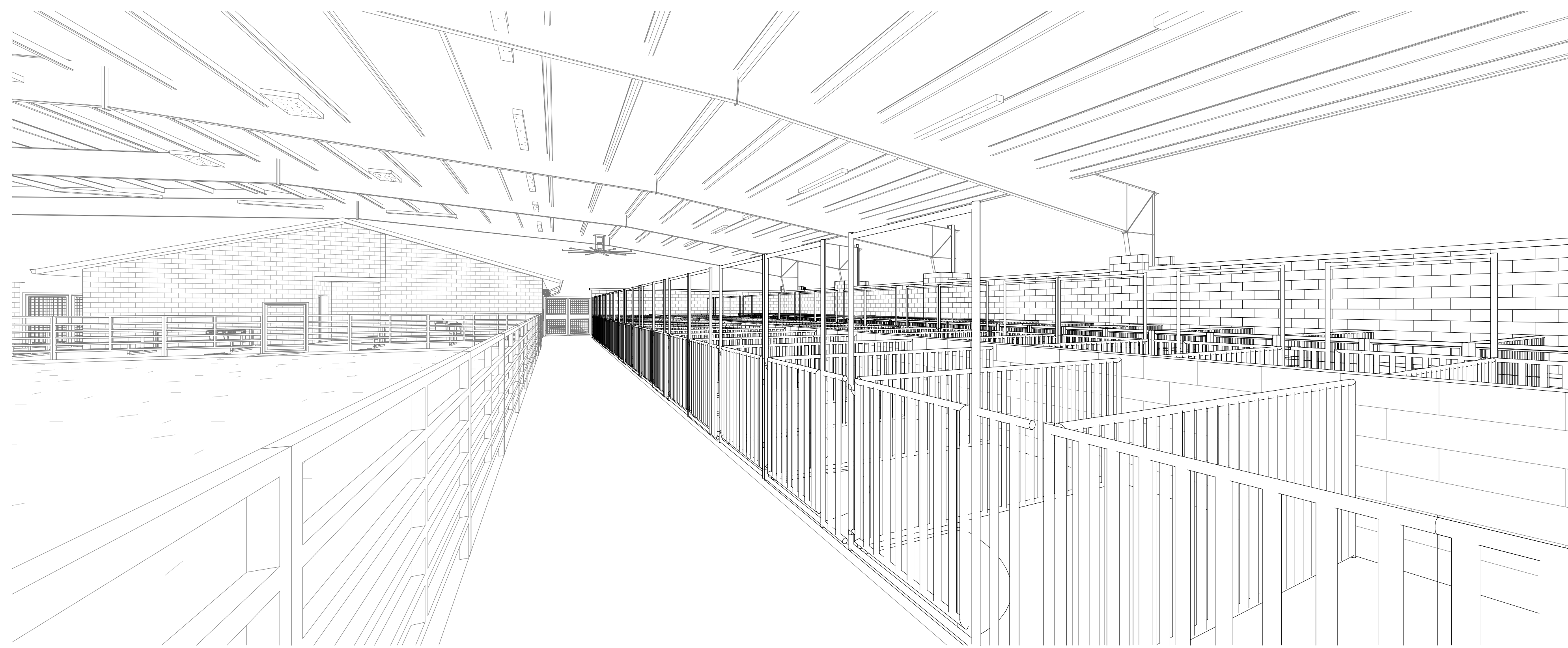

BOARD MEMBERS

- JERRY ZAMORA - PRESIDENT
- VERONICA "BETTY" R. MENDOZA - VICE PRESIDENT
- ROY VELA - SECRETARY
- PETRA B. RAMIREZ - BOARD MEMBER
- MINNIE R. RODGERS - BOARD MEMBER
- JUAN M. GONZALEZ - BOARD MEMBER
- IRIS IGLESIAS - BOARD MEMBER

DR. CAROLINA G. PEREZ - SUPERINTENDENT OF SCHOOLS

SHEET INDEX

- ARCHITECTURAL
 - A-101 EXISTING CONDITIONS OVERALL PLAN
 - A-102 DEMOLITION PLAN
 - A-103 NEW CONSTRUCTION OVERALL PLAN
- ELECTRICAL
 - E0.01 ELECTRICAL SYMBOLS AND ABBREVIATIONS
 - E2.01 ELECTRICAL POWER PLAN
 - E5.01 ELECTRICAL ONE LINE DIAGRAM & SCHEDULES
- PLUMBING
 - P0.01 PLUMBING SYMBOLS AND ABBREVIATIONS
 - P2.00 UNDERFLOOR PLUMBING PLAN
 - P2.01 PLUMBING PLAN

G-000 COVER SHEET
 FOR BLUEBEAM LABELING ONLY
 ISSUE FOR CONSTRUCTION
 File Path: C:\Users\dalvarez\Documents\SP2132500AR_MISSION_CISD_Joe Correa_Ag_Demolition\areakf226.rvt
 CHECKED BY: Checker
 DRAWN BY: Author
 Plot Stamp: 3/16/2022 3:35:01 PM

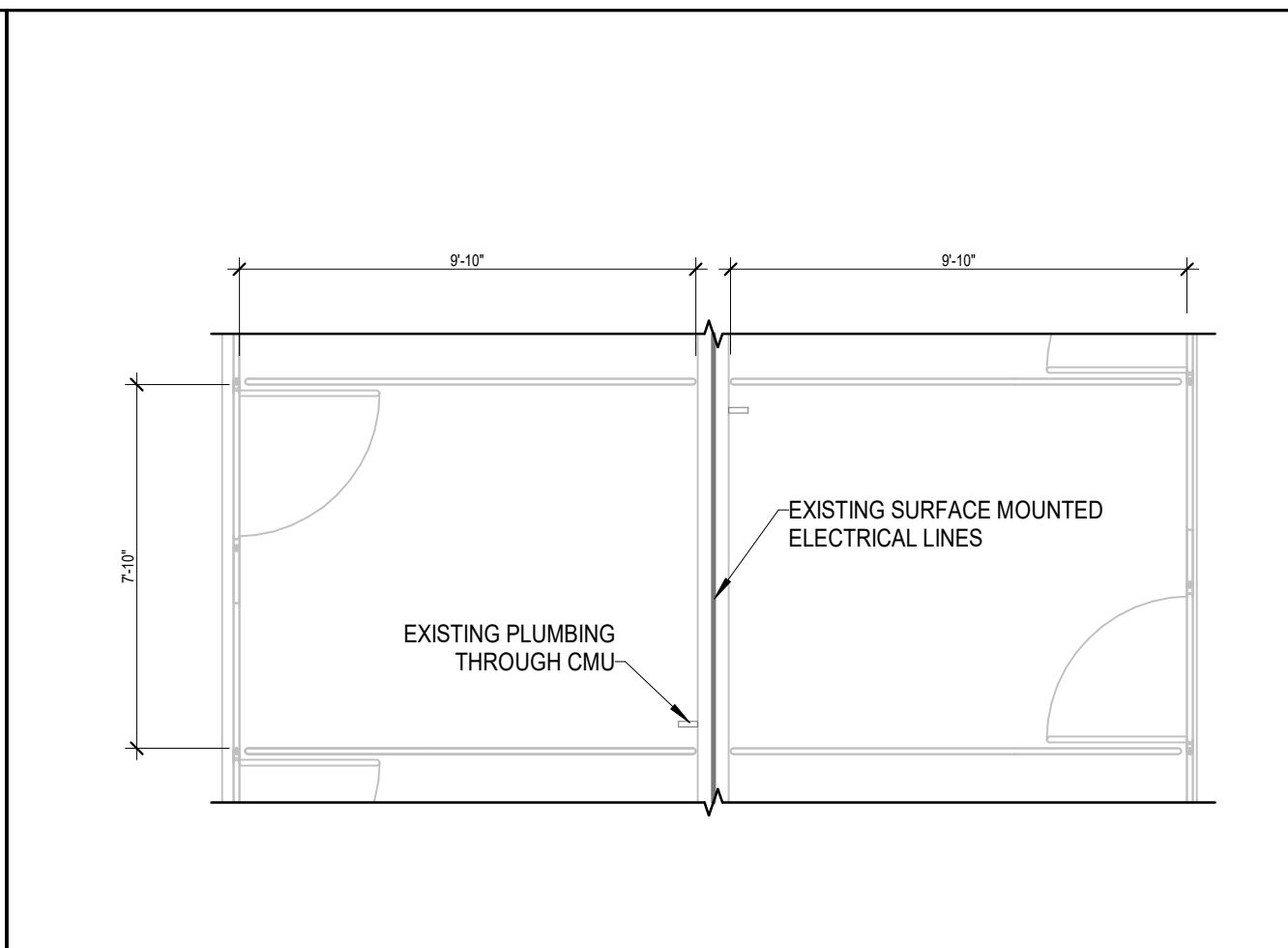
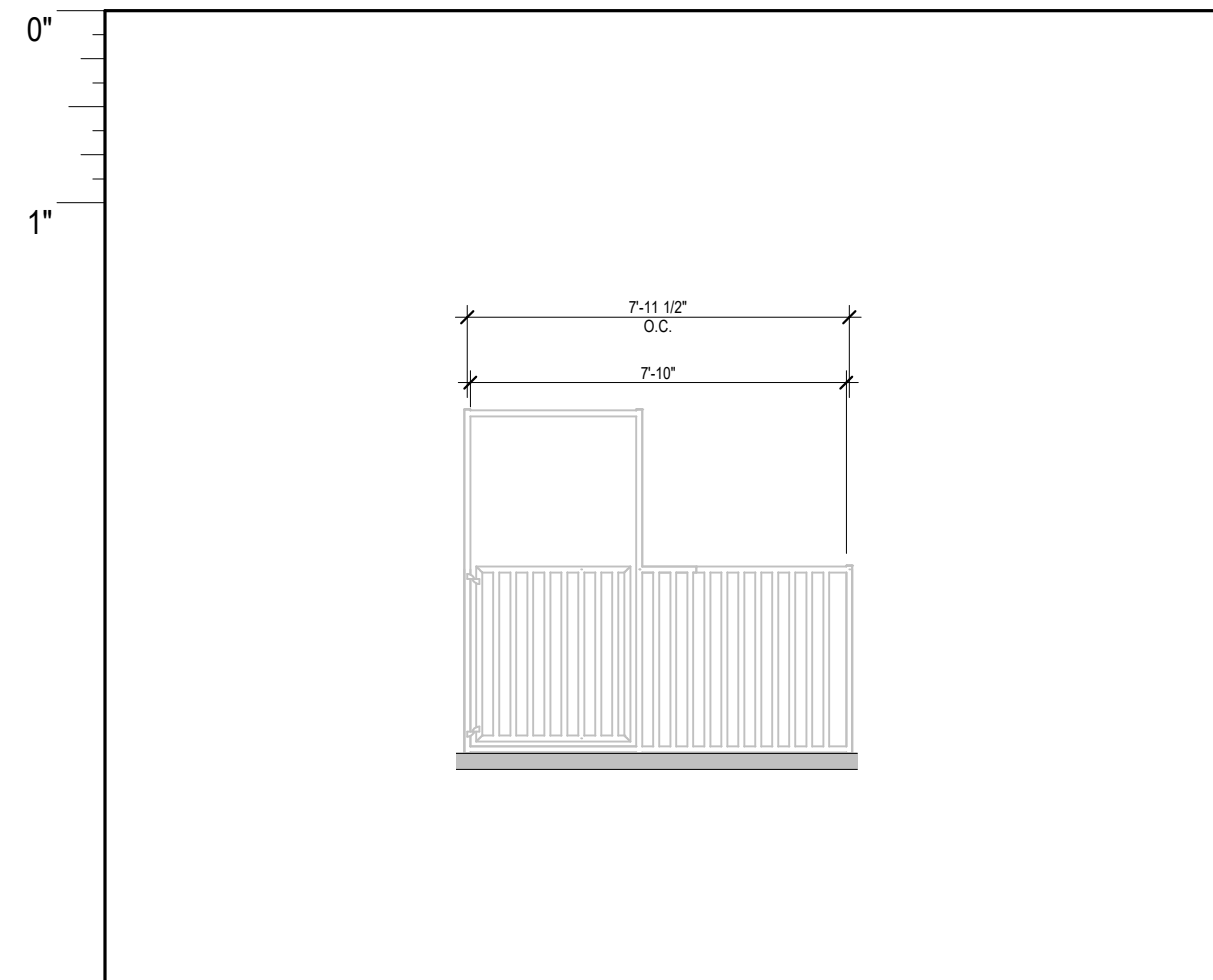

GENERAL ARCH PLAN NOTES

- DO NOT SCALE DRAWINGS. WRITTEN DIMENSIONS TAKE PRECEDENCE. CONTACT ARCH IF CLARIFICATION IS NECESSARY IN ORDER TO DETERMINE THE INTENT OF THE CONTRACT DOCUMENTS
- DRAWINGS NOTED AS "N.T.S." OR "N.T.S." ARE NOT TO SCALE
- ALL DIMENSIONS ARE TO STRUCTURAL COLUMN LINES OR THE SURFACE OF PARTITION ASSEMBLY U.N.O.
- FIELD VERIFY ALL DIMENSIONS AND EXISTING CONDITIONS BEFORE COMMENCING WORK. NOTIFY ARCH. OF ANY DISCREPANCIES PRIOR TO PROCEEDING WITH AFFECTED WORK
- NOTES OR DIMENSIONS NOTED AS "TYPICAL" OR "TYP." OR "TYP." SHALL APPLY TO CONDITIONS THAT ARE THE SAME OR SIMILAR
- DIMENSIONS NOTED AS "FIELD VERIFY" OR "J.F." OR "V.F." SHALL BE MEASURED AND CONFIRMED AT THE PROJECT SITE BY THE CONTRACTOR AND REVIEWED WITH THE ARCH. BEFORE INCORPORATING INTO THE WORK
- REFER TO OTHER DISCIPLINE DOCUMENTS FOR ADDITIONAL SCOPE OF WORK
- SALVAGED ITEMS TO BE RETURNED TO OWNER UNLESS NOTED OTHERWISE.

LEGEND

- NEW CONSTRUCTION
 - NEW CONSTRUCTION
 - EXISTING TO REMAIN
 - EXISTING TO REMAIN
 - DEMOLISH
 - NO WORK THIS AREA
- *REFER TO OVERALL PLAN FOR NEW CONSTRUCTION VS EXISTING



ARCHITECT: PBK Architects, Inc.
SAN ANTONIO
601 N. W. Loop 410, Suite 400
San Antonio, TX 78216
210-829-0123 P
210-829-0573 F
TX Firm: BR 1608

117

30 TYPICAL LAMB/GOAT PEN ELEVATION
1/8" = 1'-0"

29 TYPICAL EXISTING PEN PLAN VIEW
1/4" = 1'-0"

28 SUPPORTING PICTURES
NOT TO SCALE

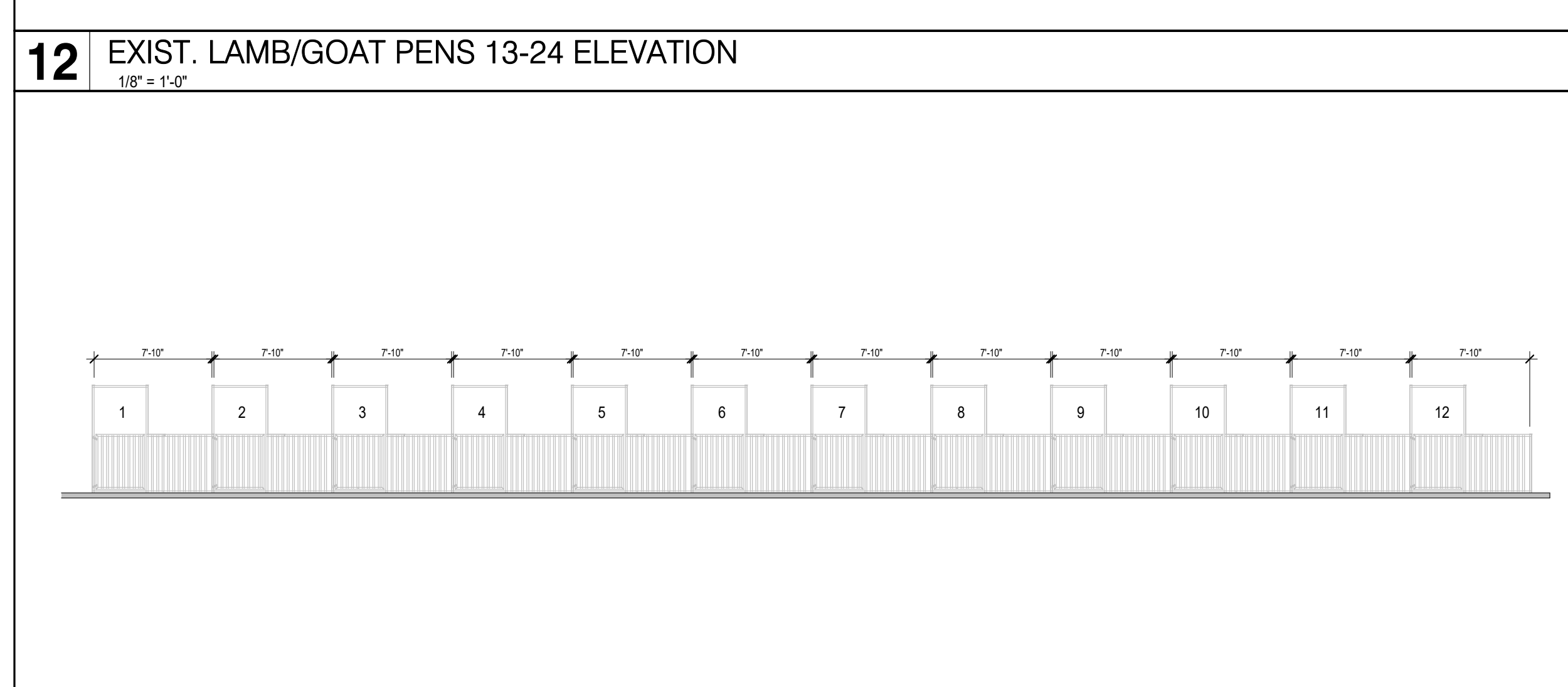
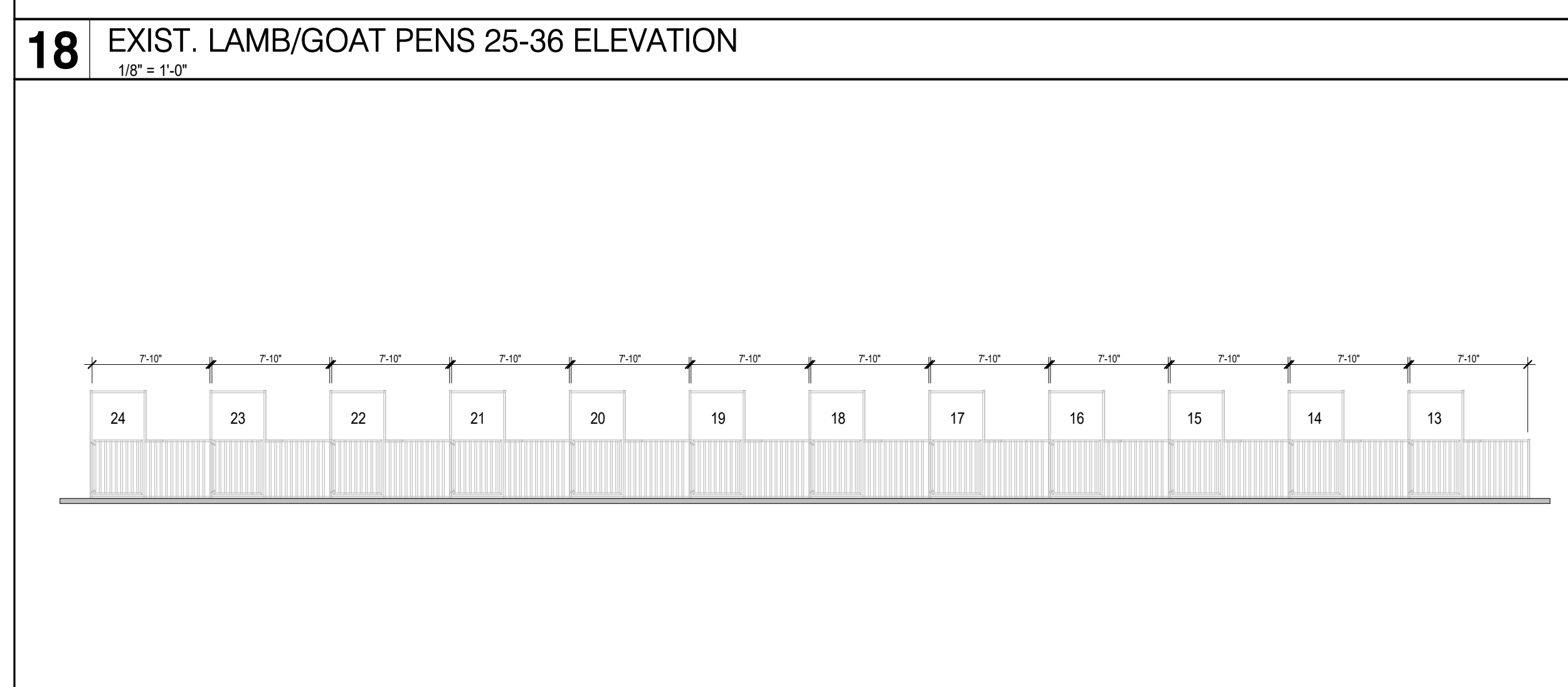
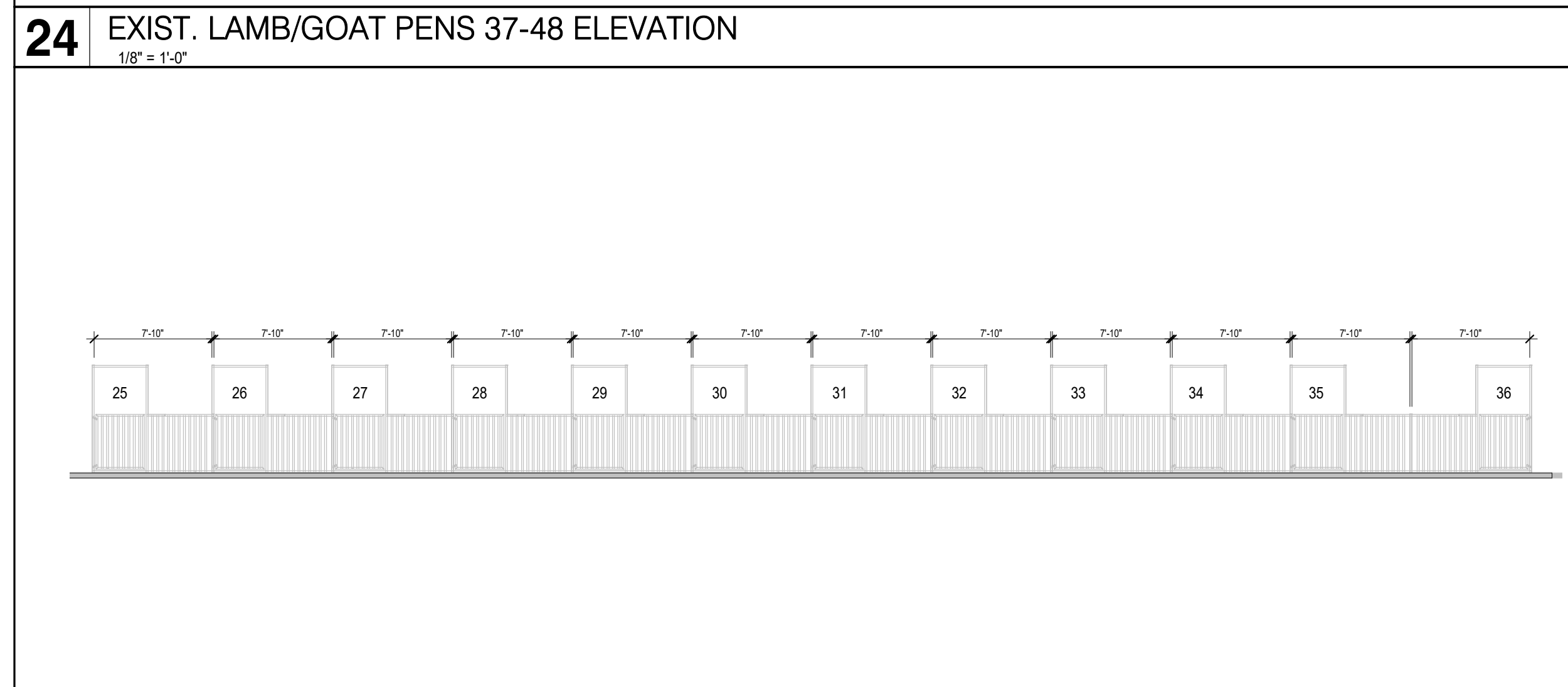
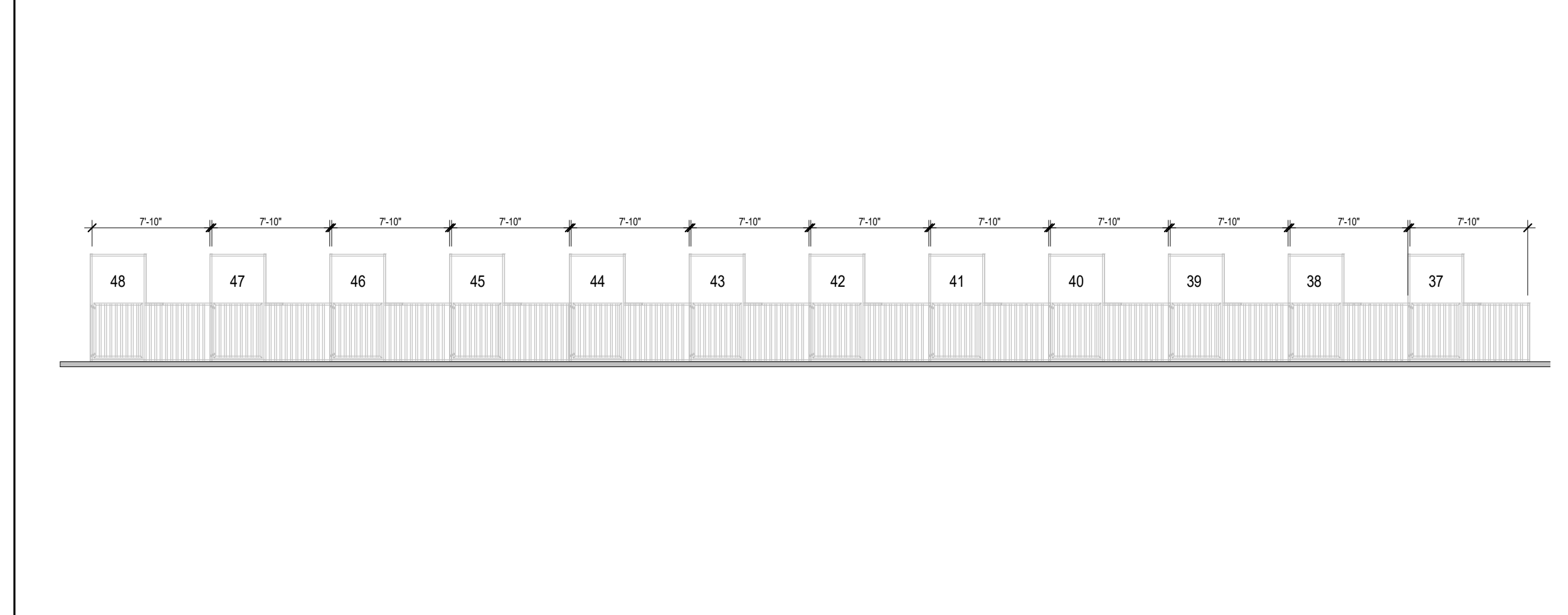

06 EXIST. LAMB/GOAT PENS 1-12 ELEVATION
1/8" = 1'-0"

04 EXISTING CONDITIONS FLOOR PLAN
1/16" = 1'-0"

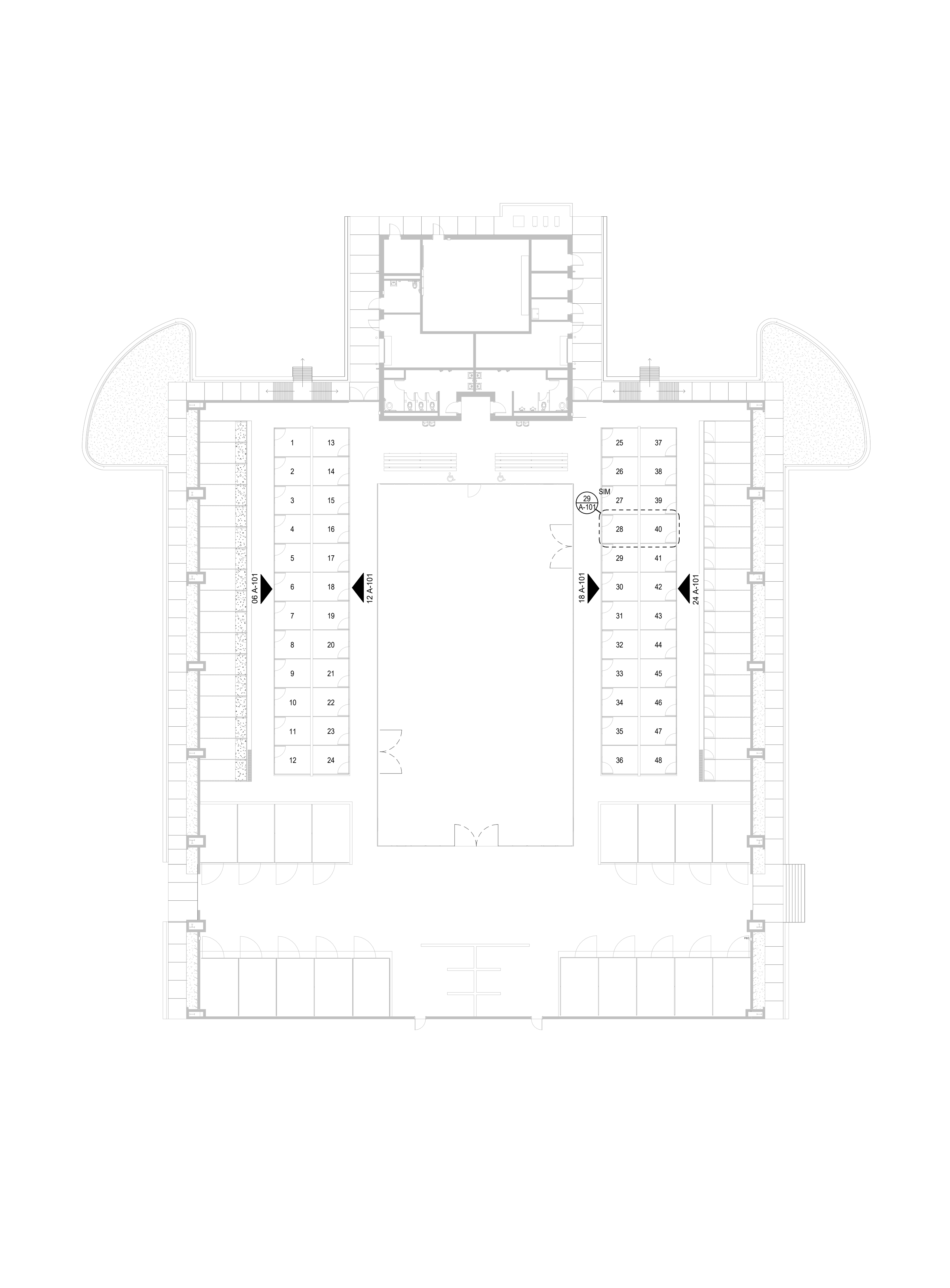

JOSE "JOE" CORREA JR AGRICULTURAL SCIENCE LAB

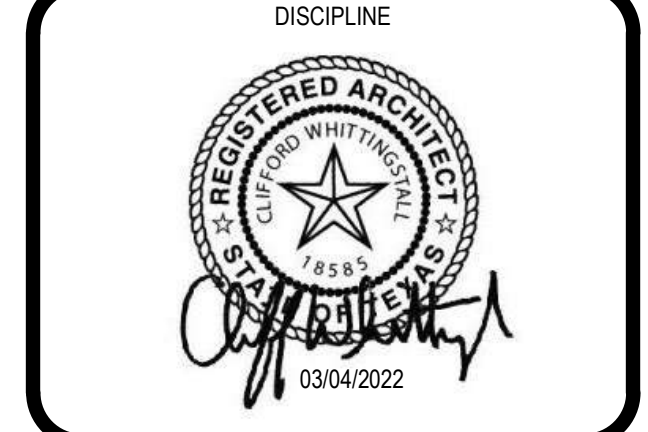
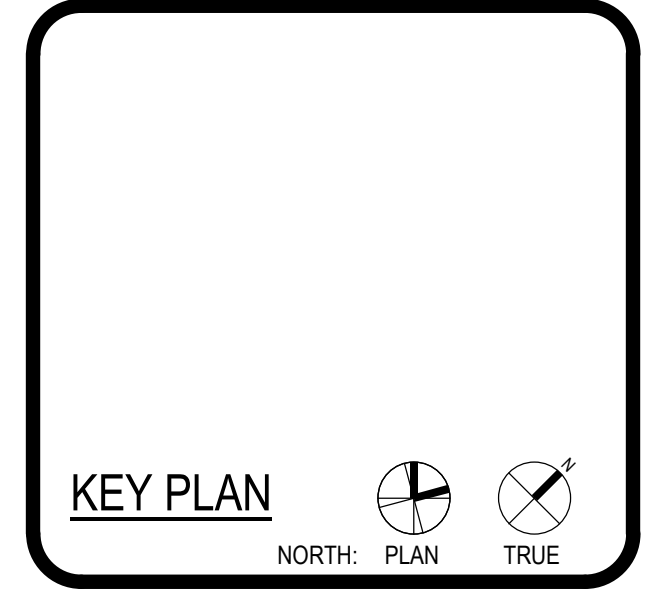

CLIENT: MISSION CISD		
DATE: 07/09/2015	PROJECT NUMBER: P2132500AR	
DRAWING HISTORY		
No.	Description	Date

ISSUE FOR CONSTRUCTION
BUILDING NUMBER
EXISTING CONDITIONS OVERALL PLAN

ISSUE FOR CONSTRUCTION

FOR BLUEBAM LABELING ONLY
 DEMOLITION PLAN
 A-102
 ISSUE FOR CONSTRUCTION



GENERAL DEMOLITION NOTES

- DEMOLITION PLANS INDICATE SOME OF THE SCOPE-OF-WORK INVOLVED FOR THE DEMOLITION PHASE OF THIS PROJECT. THE CONTRACTOR SHALL REVIEW ALL SHEETS FOR ADDITIONAL DEMOLITION SCOPE.
- CONTRACTOR SHALL VERIFY EXISTING SITE AND BUILDING CONDITIONS AND DIMENSIONS IN THE FIELD PRIOR TO DEMOLITION ACTIVITIES AND WORK.
- CONTRACTOR SHALL NOTIFY ARCHITECT OF ANY DISCREPANCIES IN WRITING.
- CONTRACTOR SHALL NOTIFY ARCHITECT AND OWNER OF ANY POSSIBLE ASBESTOS CONTAINING MATERIALS DISCOVERED BEFORE PROCEEDING WITH WORK. PROTECT INTERIOR CONSTRUCTION TO REMAIN DURING DEMOLITION AND CONSTRUCTION.
- CONTRACTOR SHALL OBTAIN ALL NECESSARY PERMITS BEFORE COMMENCING WORK.
- AFTER AWARD OF THE CONTRACT, CHANGE ORDER REQUESTS FOR ADDITIONAL MONEY WILL NOT BE APPROVED IF THE WORK COULD HAVE BEEN ANTICIPATED DURING A SITE VISIT BY THE CONTRACTOR.
- CONTRACTOR SHALL NOT SCALE DRAWINGS.
- CONTRACTOR SHALL PROVIDE ALL NECESSARY TEMPORARY SHORING, TEMPORARY BRACING, AND OR TEMPORARY SUPPORTS AS REQUIRED TO MAINTAIN STRUCTURAL INTEGRITY OF EXISTING STRUCTURE TO REMAIN AND OR EXISTING BUILDING ELEMENTS TO REMAIN.
- CONTRACTOR IS TO VERIFY THE EXACT LOCATION OF ALL EXISTING UTILITIES PRIOR TO DEMOLITION ACTIVITIES AND WORK.
- CONTRACTOR SHALL REMOVE TRASH AND DEBRIS REGULARLY AS NECESSARY TO ELIMINATE INTERFERENCE WITH ROADS, STREET, WALKS, AND ALL OTHER ADJACENT FACILITIES.
- CONTRACTOR SHALL REMOVE TRASH AND DEBRIS FROM THE SITE ON A DAILY BASIS.
- CONTRACTOR IS RESPONSIBLE FOR CONSTRUCTION OF TEMPORARY DUST AND OR SOUND PARTITION BETWEEN CONSTRUCTION AREA AND AREAS NOT IN SCOPE AS NECESSARY. DEMOLITION ACTIVITIES SHALL BE PERFORMED SO AS TO PRODUCE MINIMAL DISTURBANCE TO EXISTING FACILITY AND OCCUPANTS (USE MINIMIZE EXCESSIVE AND PROLONGED NOISE LEVELS AND DUST).
- CONTRACTOR SHALL REPAIR, REPLACE, OR PATCH EXISTING BUILDINGS, DRIVEWAYS, SIDEWALKS, CANOPIES, AND OR PARKING AREAS DAMAGED, MODIFIED, AND OR DISTURBED BY DEMOLITION WORK AT NO COST TO THE OWNER.
- ALL EXISTING EQUIPMENT THAT REMAINS SHALL BE PROTECTED DURING DEMOLITION AND OR CONSTRUCTION TO PREVENT DAMAGE. ANY DAMAGE TO REMAINING EXISTING EQUIPMENT SUSTAINED DURING DEMOLITION AND OR CONSTRUCTION SHALL BE EQUIVALENTLY REPLACED OR EQUIVALENTLY REPAIRED AT NO COST TO THE OWNER.
- CONTRACTOR SHALL PROVIDE TRAFFIC HANDLING MEASURES TO PROTECT THE GENERAL PUBLIC AT ALL TIMES, AS NECESSARY AND AS REQUIRED BY AUTHORITIES HAVING JURISDICTION.
- DO NOT INTERRUPT EXISTING UTILITIES, EXCEPT WHEN AUTHORIZED IN WRITING BY AUTHORITIES HAVING JURISDICTION. PROVIDE TEMPORARY SERVICES DURING INTERRUPTIONS TO EXISTING UTILITIES, AS ACCEPTABLE TO AUTHORITIES HAVING JURISDICTION.
- WHEN UTILITY SERVICES ARE REQUIRED TO BE REMOVED, RELOCATED, OR ABANDONED, PROVIDE BYPASS CONNECTIONS TO MAINTAIN CONTINUITY OF SERVICE BEFORE PROCEEDING WITH DEMOLITION.
- CONTRACTOR SHALL CONTACT ALL UTILITY COMPANIES INCLUDING BUT NOT LIMITED TO THE FOLLOWING: ELECTRIC, GAS, WATER, TELEPHONE, STORM SEWER, AND SANITARY SEWER FOR FIELD LOCATION AND UNDERGROUND AND OVERHEAD UTILITY LINES. PRIOR TO COMMENCEMENT OF ANY DEMOLITION WORK, CONTRACTOR SHALL IDENTIFY ALL ELECTRICAL CIRCUITS SERVICING THE AREA INVOLVED WITH THIS DEMOLITION. THOSE CIRCUITS SHALL THEN BE LOCKED OUT AND TAGGED OUT IF THEY DO NOT SERVICE ANY OF THE REMAINING BUILDING. THOSE CIRCUITS WHICH ARE IDENTIFIED TO SERVICE BOTH THE AREA TO BE DEMOLISHED AND THE REMAINING BUILDING SHALL BE SPLIT SO AS TO KILL ALL ELECTRICAL POWER TO THE AREA TO BE DEMOLISHED WHILE MAINTAINING POWER TO THE REMAINDER OF THE BUILDING.
- CONTRACTOR SHALL RELOCATE UTILITIES AND EQUIPMENT AS REQUIRED TO ACCOMMODATE NEW HVAC, ELECTRICAL, PLUMBING, AND TECHNOLOGY REQUIREMENTS FOR NEW WORK.
- PROTECT EXISTING SITE ELEMENTS AND EXISTING LANDSCAPING TO REMAIN. PROTECTION SHALL INCLUDE BUT NOT BE LIMITED TO EXISTING TREES AND OTHER EXISTING VEGETATION INDICATED TO REMAIN IN PLACE AGAINST UNNECESSARY CUTTING, BREAKING, OR SKINNING OF ROOTS, SKINNING OR GRUBBING OF BARK, SMOTHERING OF TREES BY STOCKPILING CONSTRUCTION MATERIAL OR EXCAVATED MATERIAL WITHIN DRIP LINES.
- CONTRACTOR SHALL REGRADE AND HYDROMULCH AREAS AFFECTED BY DEMOLITION.
- OWNER HAS RIGHT OF FIRST REFUSAL OF ALL ITEMS REMOVED AS PART OF THE SCOPE OF WORK, WHETHER IDENTIFIED AS SALVAGE OR NOT.
- NOTIFY THE BUILDING OWNER OF ANY MATERIALS, FIXTURES, ETC. TO BE REMOVED THAT ARE DEEMED SALVAGEABLE. TURN OVER ANY REQUESTED ITEMS TO THE BUILDING OWNER IN GOOD AND CLEAN CONDITION.
- ALL FURNITURE WILL BE REMOVED OR RELOCATED BY THE OWNER AS NECESSARY PRIOR TO THE DEMOLITION WORK OF THIS PROJECT. CONTRACTOR SHALL COORDINATE WITH OWNER AS REQUIRED.
- REMOVE EXISTING CONSTRUCTION TO THE EXTENT INDICATED ON THE DRAWINGS. SHOULD ANY DAMAGE OCCUR TO ANY EXISTING CONSTRUCTION TO REMAIN, THE CONTRACTOR SHALL REPAIR THE DAMAGE TO MATCH EXISTING AND OR ADJACENT CONSTRUCTION AT NO COST TO THE OWNER.
- MAINTAIN ANY AND ALL EXISTING FIRE-RATED ASSEMBLIES THAT ARE TO REMAIN, AND THEIR ASSOCIATED FIRE-RATINGS, INCLUDING BUT NOT LIMITED TO ALL ASSOCIATED EXISTING FIRE-RATED OPENINGS, ALL ASSOCIATED EXISTING FIRE-RATED PENETRATIONS, AND ALL ASSOCIATED EXISTING FIRE-RATED FIRESTOPPING CONDITIONS.
- WHEN UNANTICIPATED MECHANICAL, ELECTRICAL, OR STRUCTURAL ELEMENTS THAT CONFLICT WITH THE INTENDED FUNCTION OR DESIGN ARE ENCOUNTERED, DETERMINE THE NATURE AND EXTENT OF THE CONFLICT AND NOTIFY THE ARCHITECT IMMEDIATELY FOR RESOLUTION.
- REMOVE, PATCH, AND REPAIR ALL ABANDONED ROOF PENETRATIONS RESULTING FROM WORK.
- SAW-CUT AND REMOVE EXISTING FLOOR FINISHES AND FLOOR SLABS AS REQUIRED TO INSTALL NEW FIXTURES, ITEMS, AND OR DEVICES FOR ALL SCOPE-OF-WORK PERTAINING TO NEW MECHANICAL WORK, NEW PLUMBING UTILITIES, NEW PLUMBING WORK, NEW ELECTRICAL WORK, AND NEW TECHNOLOGY WORK. SPLIT NEW REINFORCING BARS DOWLED INTO EXHIBITING CONCRETE AND PROVIDE NEW VAPOR RETARDER AND NEW CONTINUOUS WATERSTOPS AT JOINT BETWEEN NEW CONCRETE FLOOR SLAB AND EXISTING CONCRETE FLOOR SLAB. PATCH WITH NEW 3000 PSI MINIMUM CONCRETE AND PREPARE FLOOR, INCLUDING NEW CONCRETE, TO RECEIVE NEW FLOOR FINISHES. COORDINATE WITH STRUCTURAL.
- EXISTING WALLS (OR PORTIONS OF WALLS) TO BE REMOVED SHALL BE CUT FLUSH WHERE INTERSECTING WITH WALLS TO REMAIN. REMAINING WALLS TO BE PATCHED AND FINISHED SMOOTH.
- NEW OPENING TO BE CUT IN EXISTING WALLS SHALL BE SAW-CUT AT LOCATIONS INDICATED TO THE HEIGHT AND WIDTH INDICATED. NEW LINTELS SHALL BE INSTALLED TO SUPPORT EXISTING WALL CONSTRUCTION ABOVE AS INDICATED ON THE DRAWINGS, OR IF NOT INDICATED, AS REQUIRED FOR NEW WALL CONSTRUCTION PER STRUCTURAL DRAWINGS. COORDINATE LOCATIONS OF ALL NEW OPENINGS IN EXISTING WALLS AND PARTITIONS WITH ARCHITECTURAL PLANS.
- WHERE EXISTING WALL OPENINGS ARE TO BE NEWLY CLOSED-OFF, REMOVE ANY EXISTING OPENING FRAME AND PATCH AND REPAIR EXISTING WALL TO MATCH EXISTING ADJACENT MATERIALS AND FINISHES, UNLESS NOTED OTHERWISE.
- WHERE EXISTING INTERIOR WALLS ARE REPLACED OR REMOVED, REMOVE MEPT SYSTEMS BACK TO PANEL, OR MECHANICAL ROOM, OR FARTHEST POSSIBLE POINT WITHOUT DISTURBING EXISTING CONSTRUCTION. REMOVE EXISTING MECHANICAL EQUIPMENT, RELOCATE POWER PER MEPT DRAWINGS.
- REFER TO MEPT DRAWINGS FOR DEMOLITION OF MEPT SYSTEMS. IDENTIFY WORK REQUIRED BY THIS CONTRACTOR WHICH MAY AFFECT DEMOLITION AND OR REPAIRS OF ARCHITECTURAL ELEMENTS. COORDINATE WITH RELATED SUBCONTRACTORS THE EXTENT OF ALL DEMOLITION WORK.
- PATCH FLOORS, WALLS AND CEILING WHICH REMAIN AT LOCATIONS WHERE PIPES, CONDUITS, ETC. ARE REMOVED AS REQUIRED TO MATCH EXISTING CONDITIONS OR TO RECEIVE NEW FINISHES.
- WHERE EXISTING FINISH FLOOR IS REMOVED, PREPARE FLOOR SURFACE TO RECEIVE NEW FLOORING.
- ALL DASHED LINES ARE DEMOLITION LINES U.N.O.



ARCHITECT: **PBK Architects, Inc.**
 SAN ANTONIO
 601 N. W. Loop 410, Suite 400
 San Antonio, TX 78216
 210-829-0123 P
 210-829-0578 F
 TX Firm BR 1608

JOSE "JOE" CORREA JR AGRICULTURAL SCIENCE LAB



KEY PLAN
 NORTH: PLAN TRUE

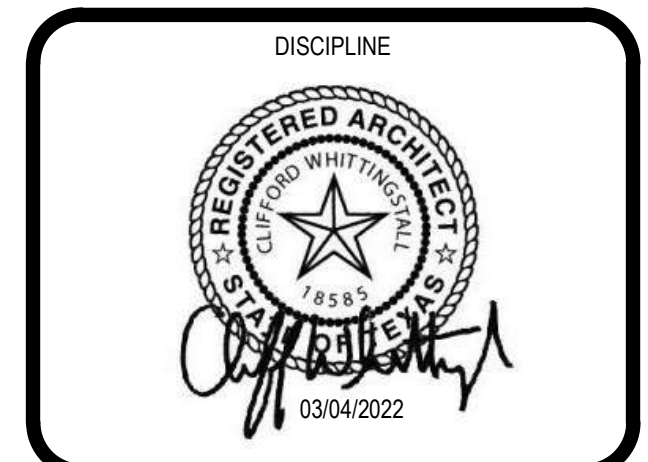

CLIENT: MISSION CISD
 DATE: 07/09/2015 PROJECT NUMBER: P2132500AR
 DRAWING HISTORY

No.	Description	Date

ISSUE FOR CONSTRUCTION
 BUILDING NUMBER
DEMOLITION PLAN

A-102

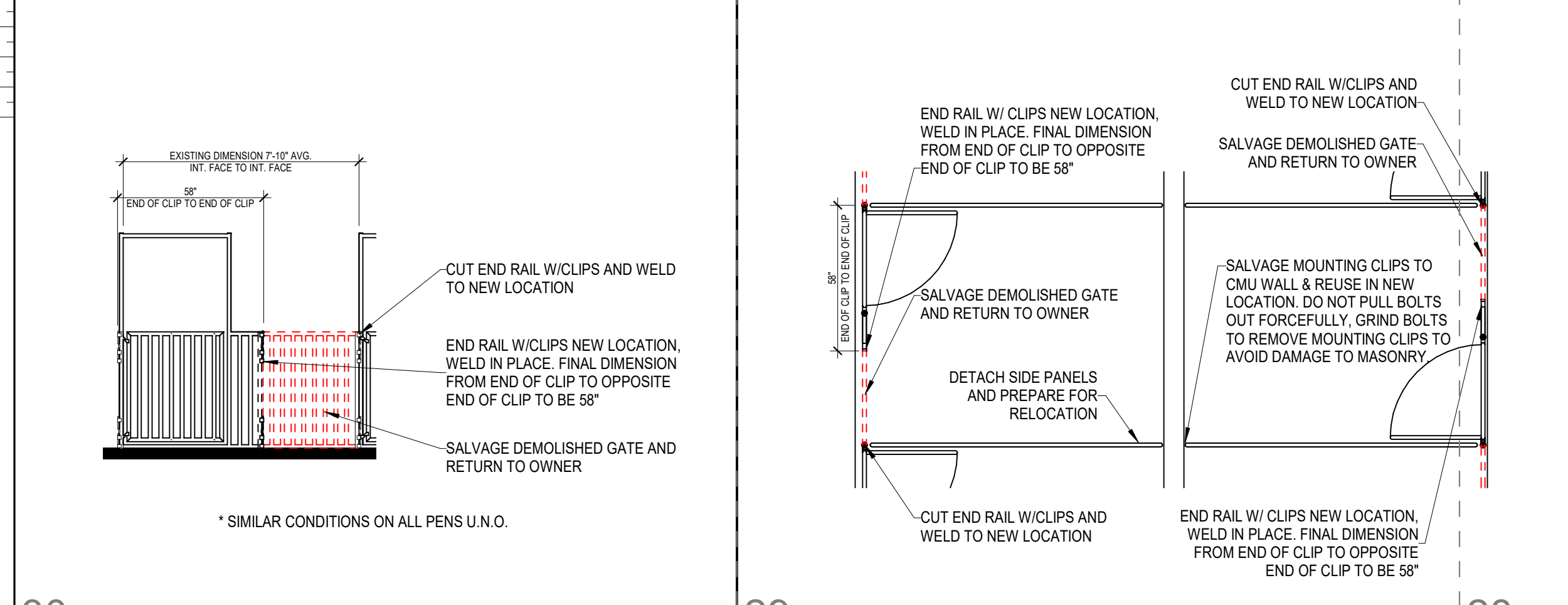

30 TYPICAL LAMB/GOAT PEN ELEVATION 1/4" = 1'-0"
29 TYPICAL LAMB/GOAT PEN PLAN VIEW 1/4" = 1'-0"
28 SUPPORTING PICTURES NOT TO SCALE

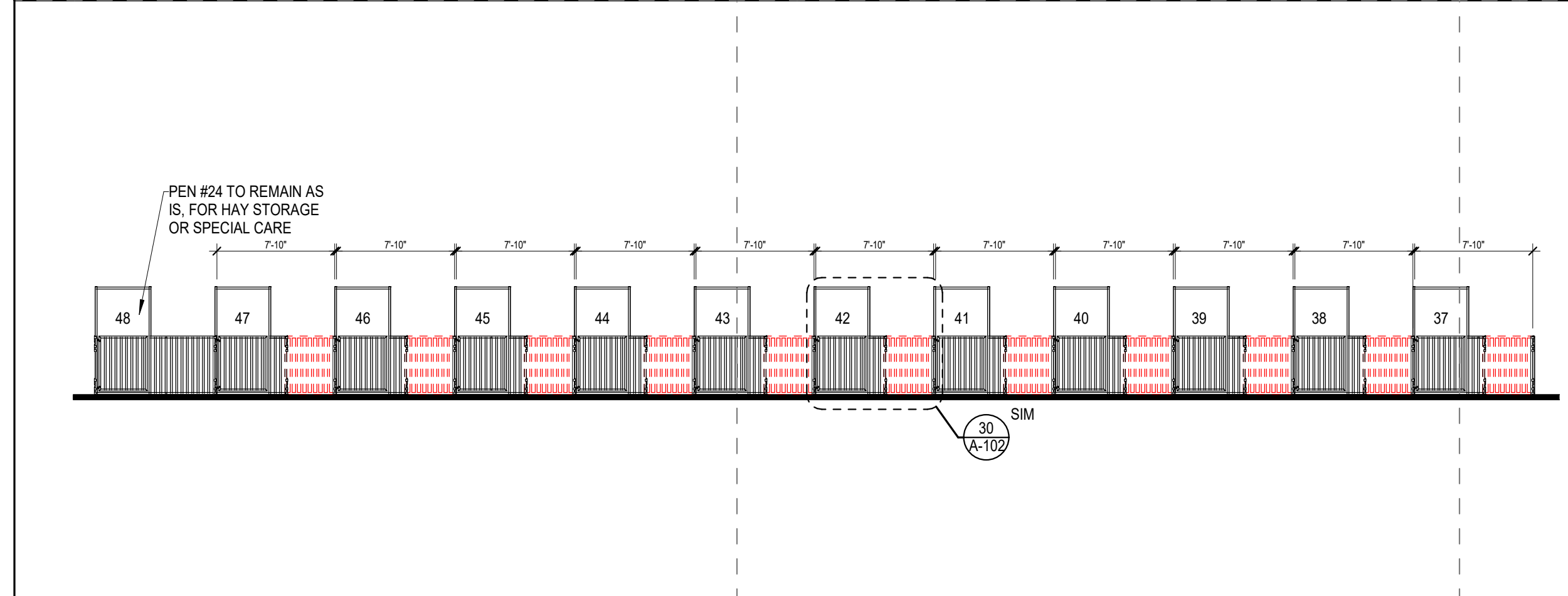

24 DEMO. LAMB/GOAT PENS 37-48 ELEVATION 1/8" = 1'-0"

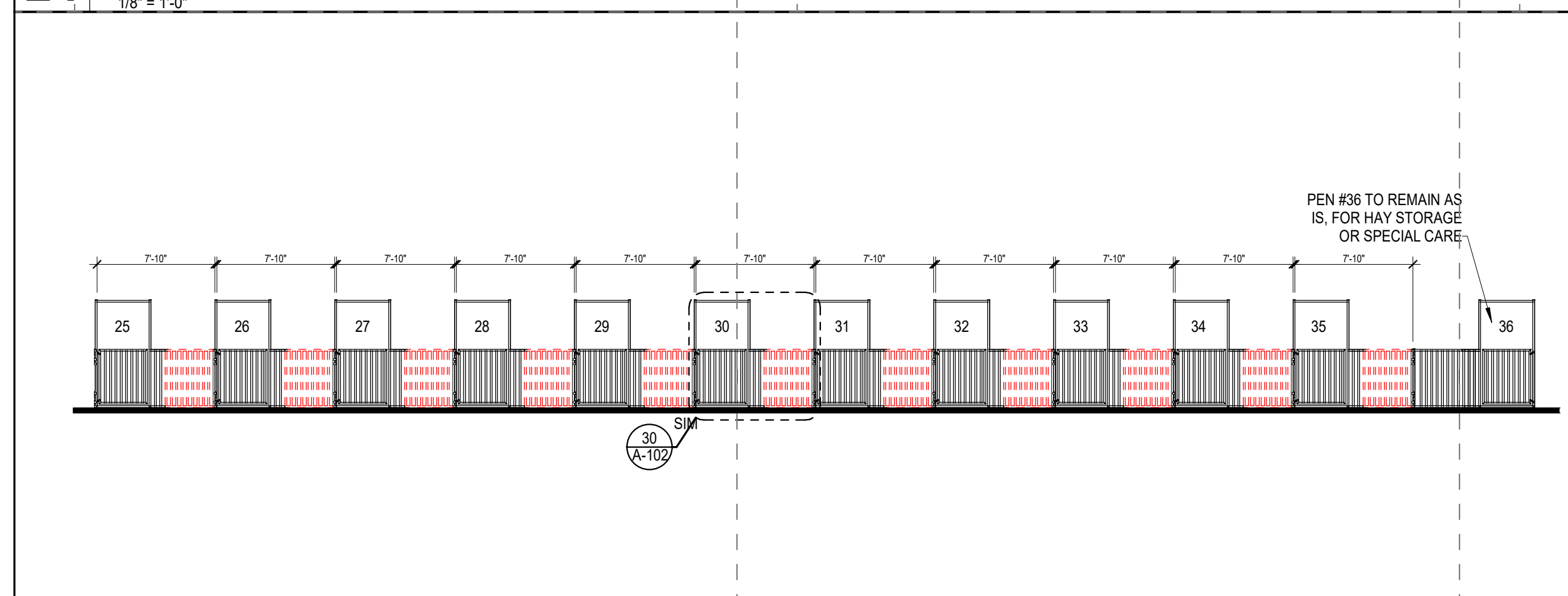

18 DEMO. LAMB/GOAT PENS 25-36 ELEVATION 1/8" = 1'-0"

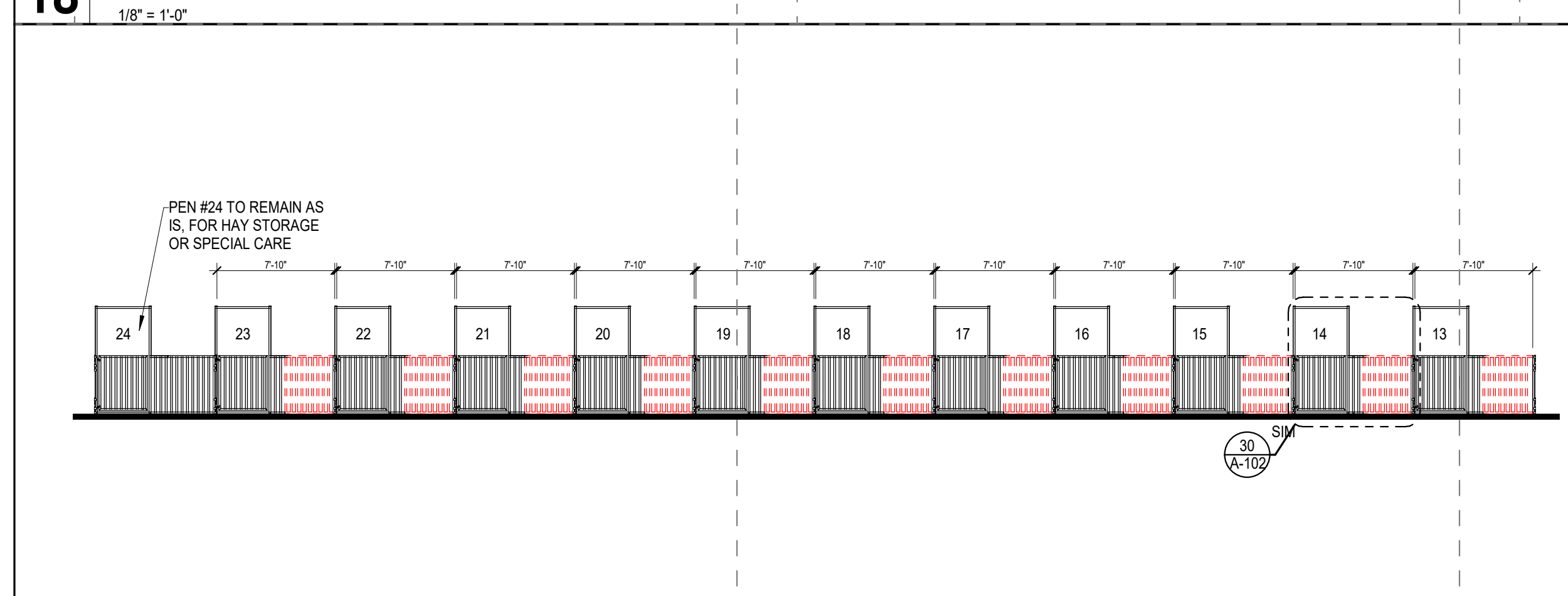

12 DEMO. LAMB/GOAT PENS 13-24 ELEVATION 1/8" = 1'-0"

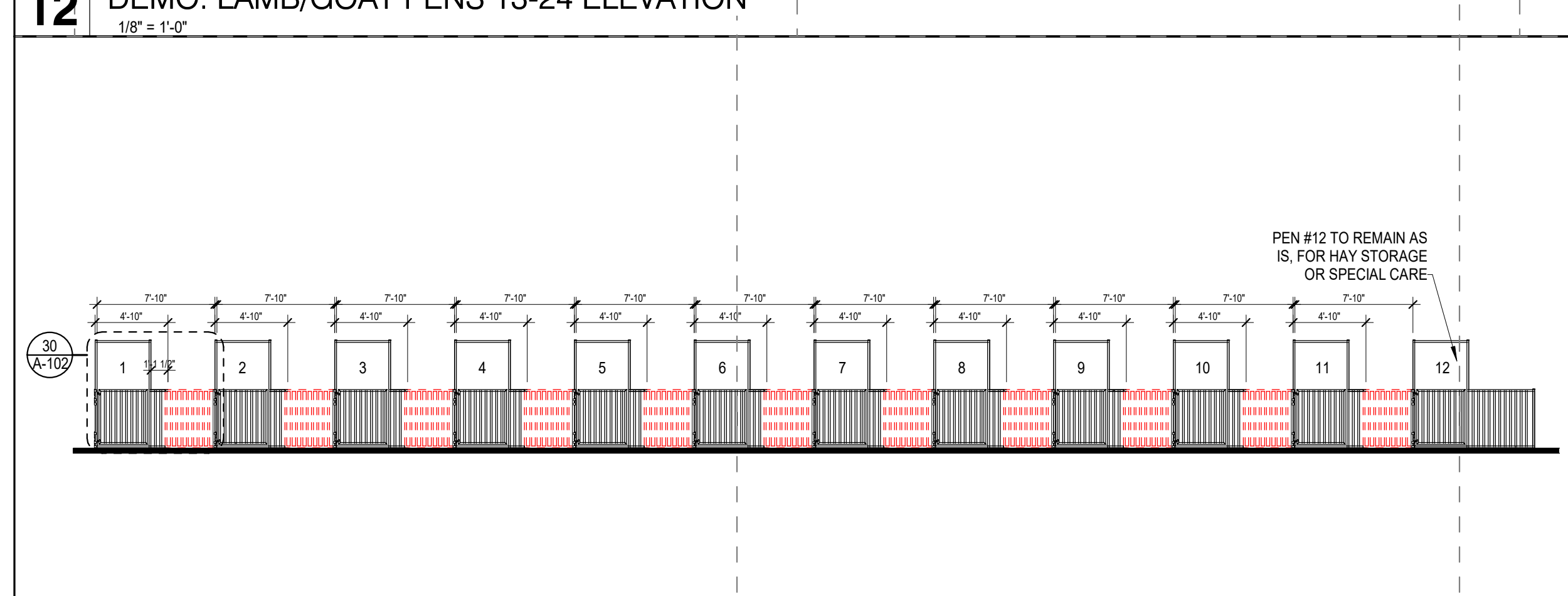

06 DEMO. LAMB/GOAT PENS 1-12 ELEVATION 1/8" = 1'-0"

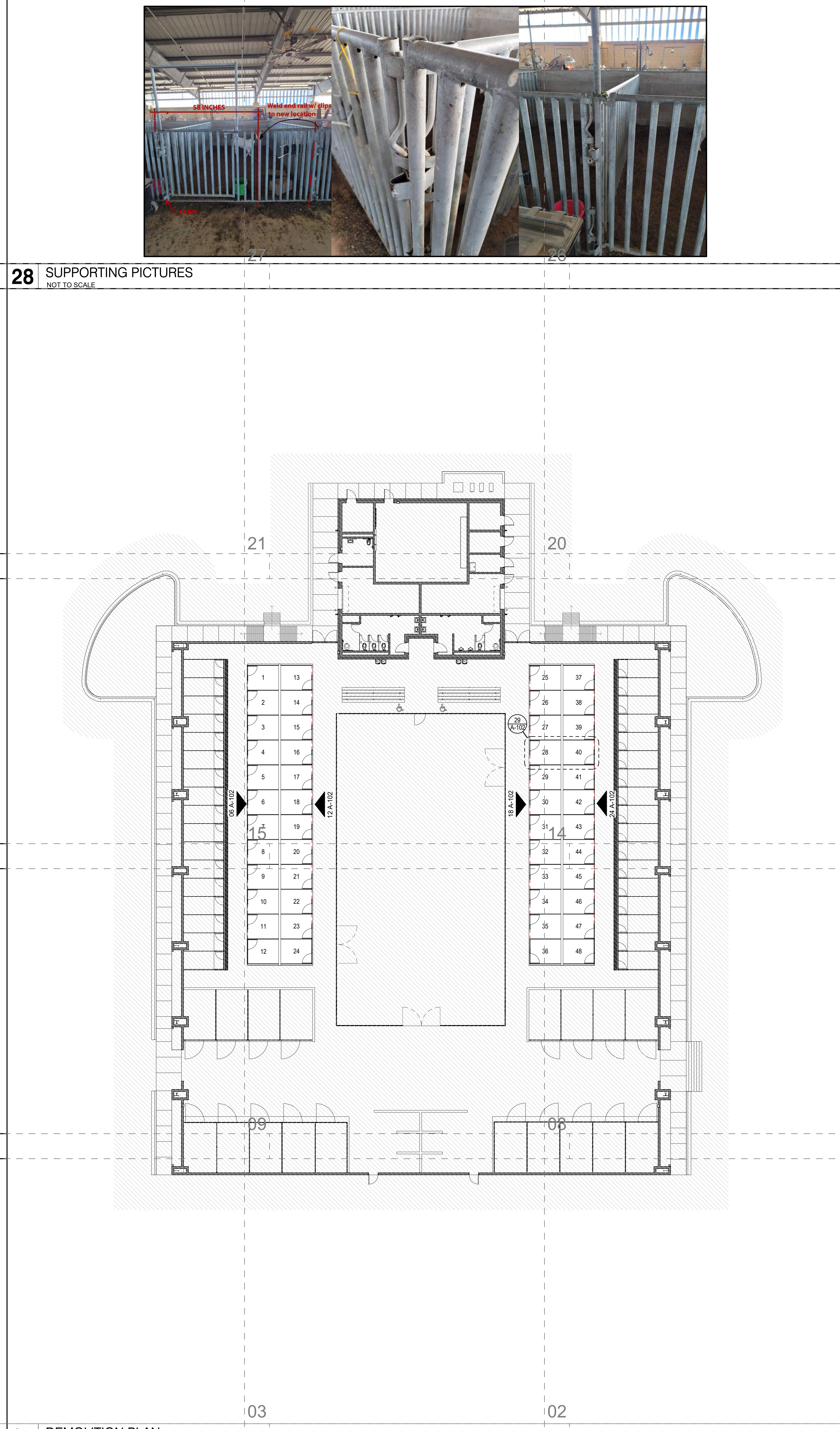

04 DEMOLITION PLAN 1/16" = 1'-0"

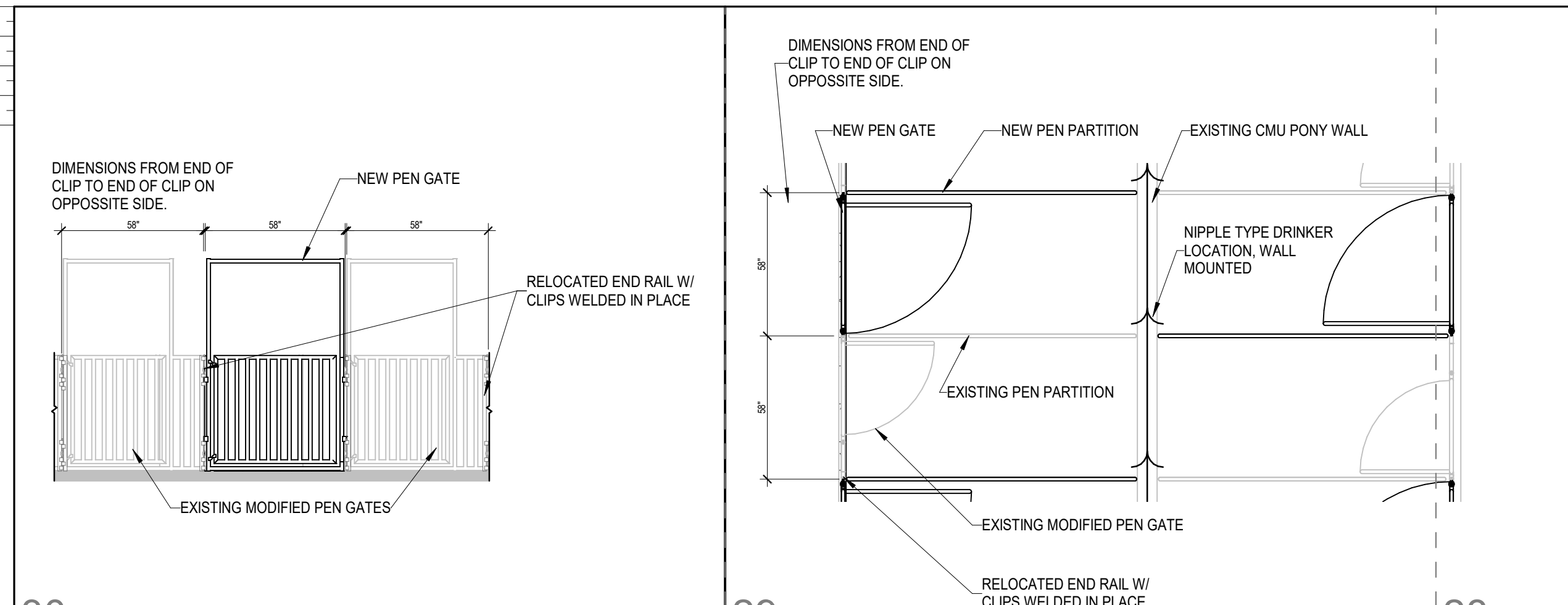

30 TYPICAL NEW PEN ELEVATION
1/4" = 1'-0"

29 TYPICAL NEW PEN PLAN VIEW
1/4" = 1'-0"



28 SUPPORTING PICTURES
NOT TO SCALE

GENERAL ARCH PLAN NOTES

- DO NOT SCALE DRAWINGS. WRITTEN DIMENSIONS TAKE PRECEDENCE. CONTACT ARCH IF CLARIFICATION IS NECESSARY IN ORDER TO DETERMINE THE INTENT OF THE CONTRACT DOCUMENTS
- DRAWINGS NOTED AS "N.T.S." OR "NTS" ARE NOT TO SCALE
- ALL DIMENSIONS ARE TO STRUCTURAL COLUMN LINES OR THE SURFACE OF PARTITION ASSEMBLY U.N.O.
- FIELD VERIFY ALL DIMENSIONS AND EXISTING CONDITIONS BEFORE COMMENCING WORK. NOTIFY ARCH. OF ANY DISCREPANCIES PRIOR TO PROCEEDING WITH AFFECTED WORK
- NOTES OR DIMENSIONS NOTED AS "TYPICAL" OR "TYP" OR "TYP" SHALL APPLY TO CONDITIONS THAT ARE THE SAME OR SIMILAR
- DIMENSIONS NOTED AS "FIELD VERIFY" OR "V.F." OR "V.F." SHALL BE MEASURED AND CONFIRMED AT THE PROJECT SITE BY THE CONTRACTOR AND REVIEWED WITH THE ARCH. BEFORE INCORPORATING INTO THE WORK
- REFER TO OTHER DISCIPLINE DOCUMENTS FOR ADDITIONAL SCOPE OF WORK
- SALVAGED ITEMS TO BE RETURNED TO OWNER UNLESS NOTED OTHERWISE.

LEGEND

- NEW CONSTRUCTION
 - NEW CONSTRUCTION
 - EXISTING TO REMAIN
 - EXISTING TO REMAIN
 - DEMOLISH
 - NO WORK THIS AREA
- *REFER TO OVERALL PLAN FOR NEW CONSTRUCTION VS EXISTING

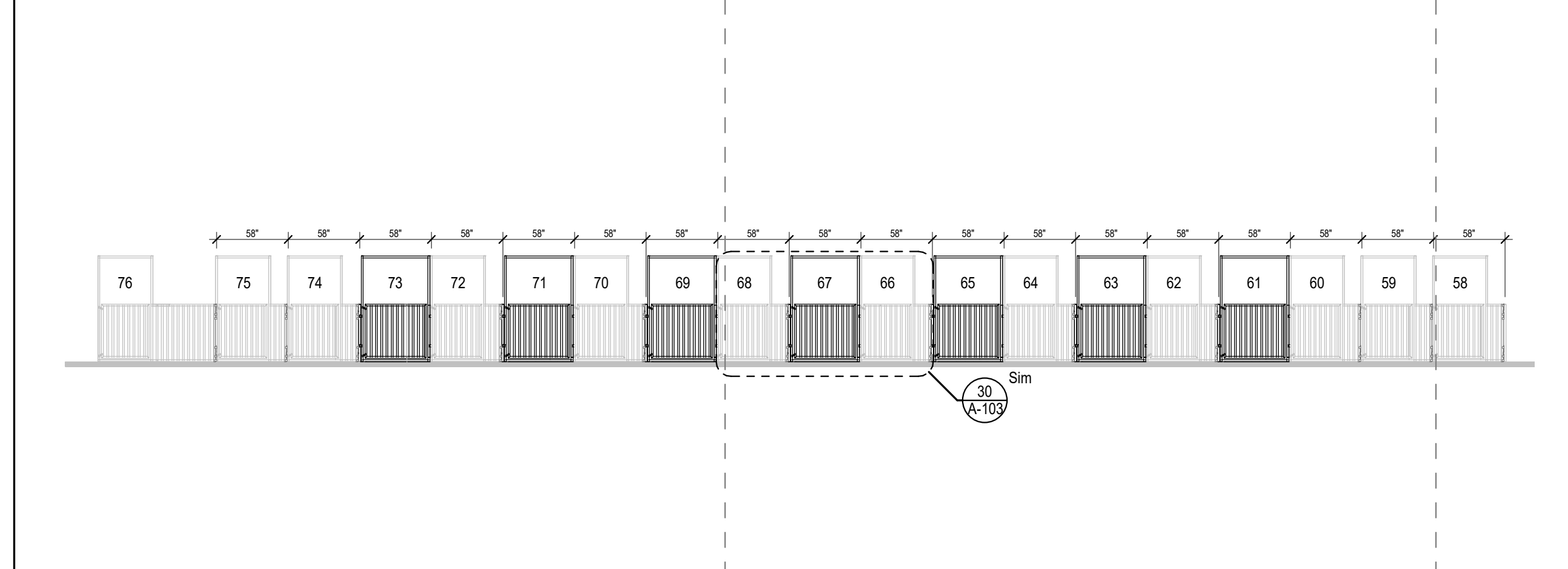

24 NEW CONSTRUCTION LAMB/GOAT PENS 58-76 ELEVATION
1/8" = 1'-0"

23

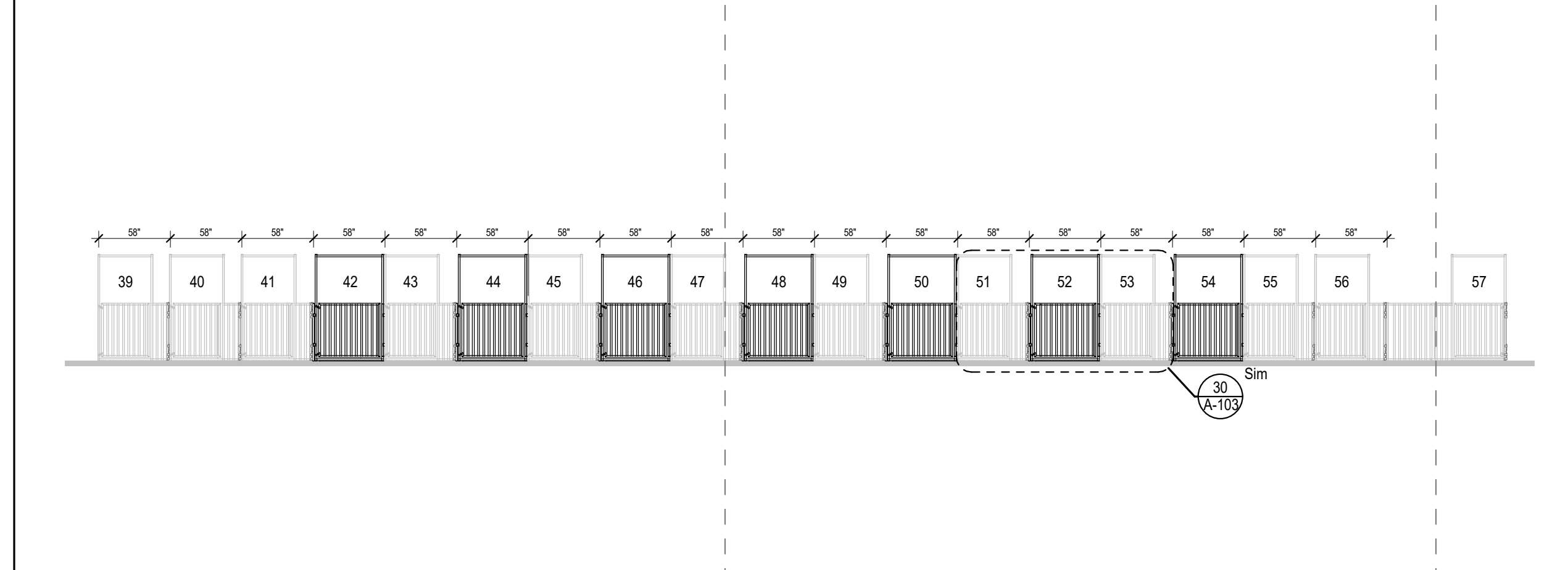

18 NEW CONSTRUCTION LAMB/GOAT PENS 39-57 ELEVATION
1/8" = 1'-0"

17

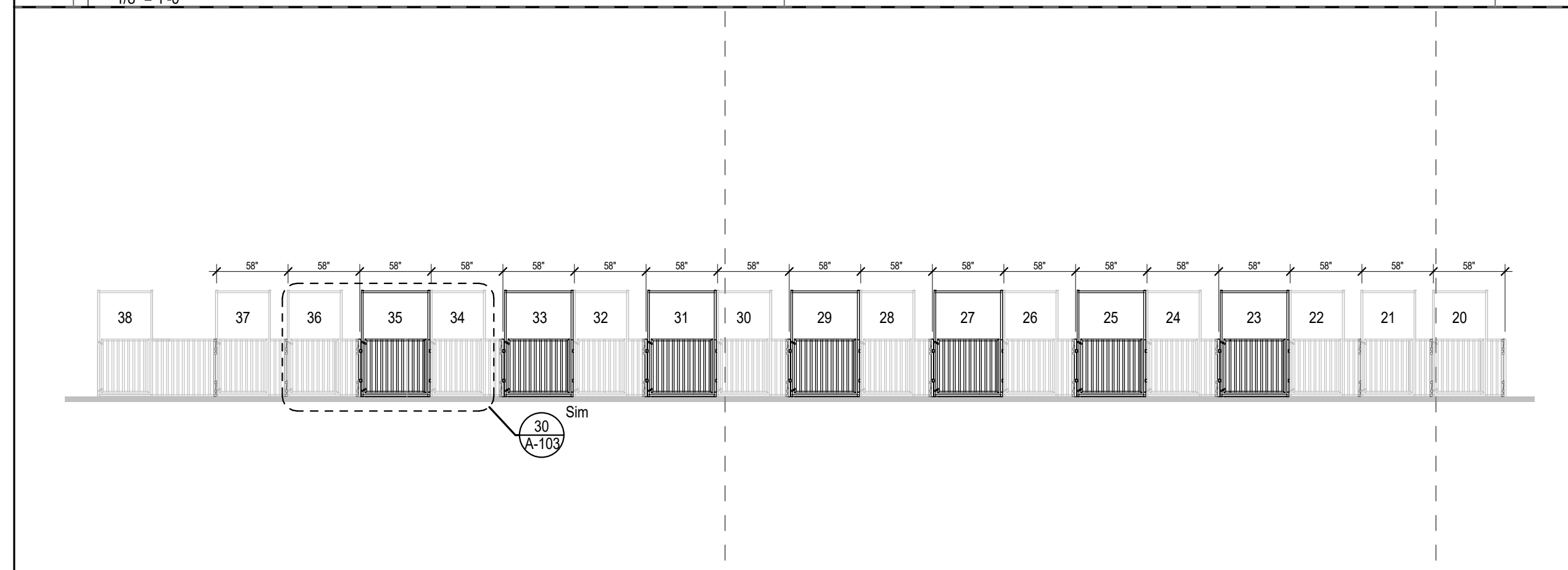

12 NEW CONSTRUCTION LAMB/GOAT PENS 20-38 ELEVATION
1/8" = 1'-0"

11

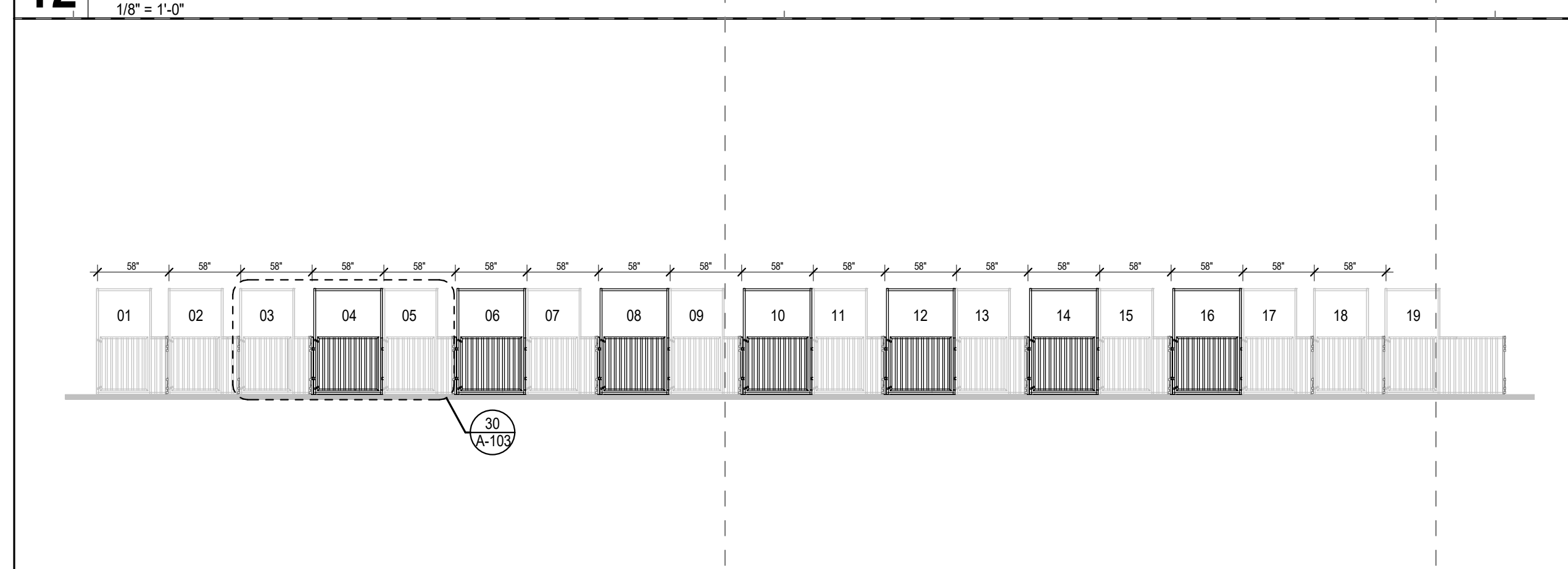

06 NEW CONSTRUCTION LAMB/GOAT PENS 1-19 ELEVATION
1/8" = 1'-0"

05

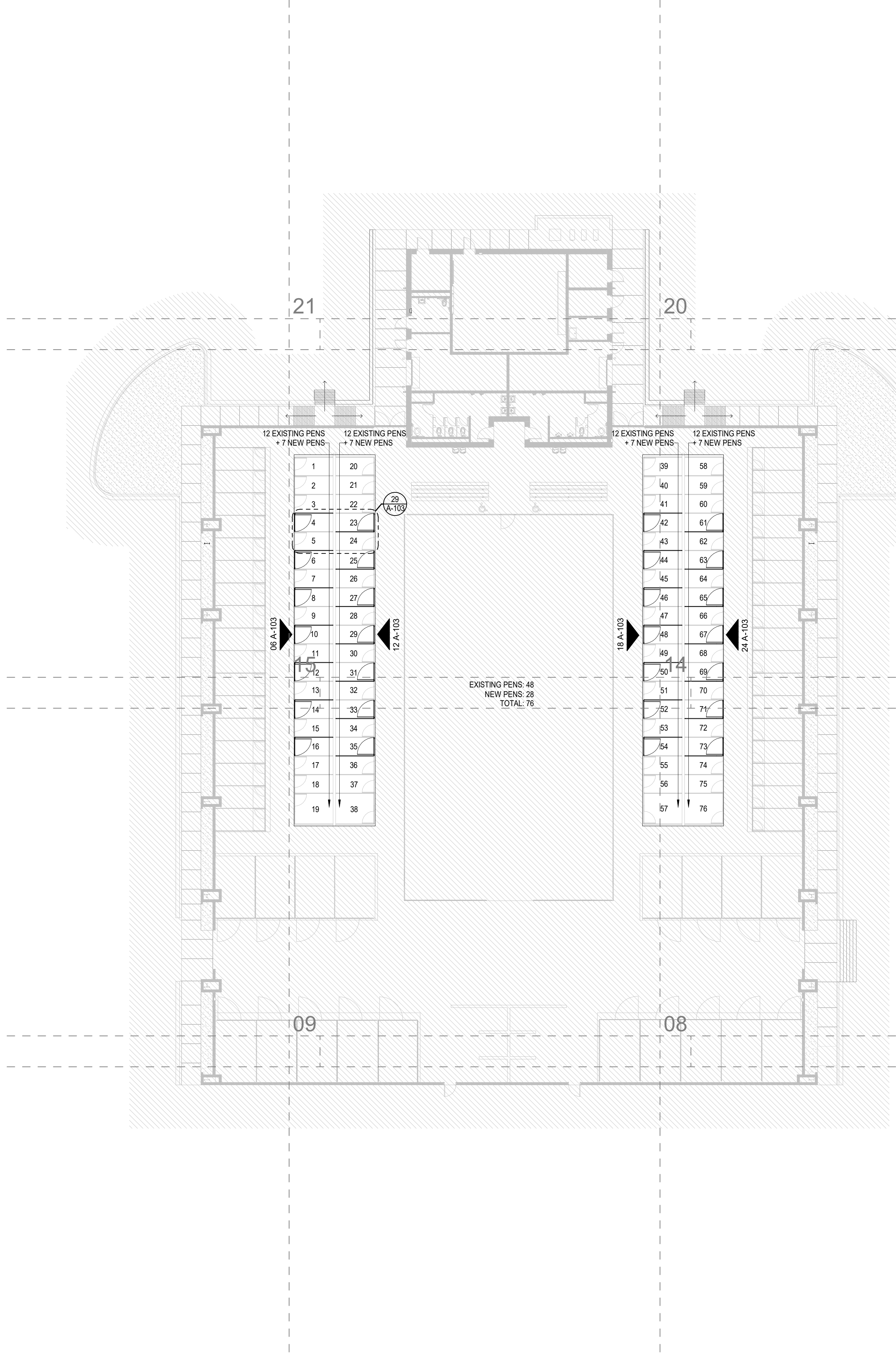

04 FLOOR PLAN - NEW CONSTRUCTION
1/16" = 1'-0"

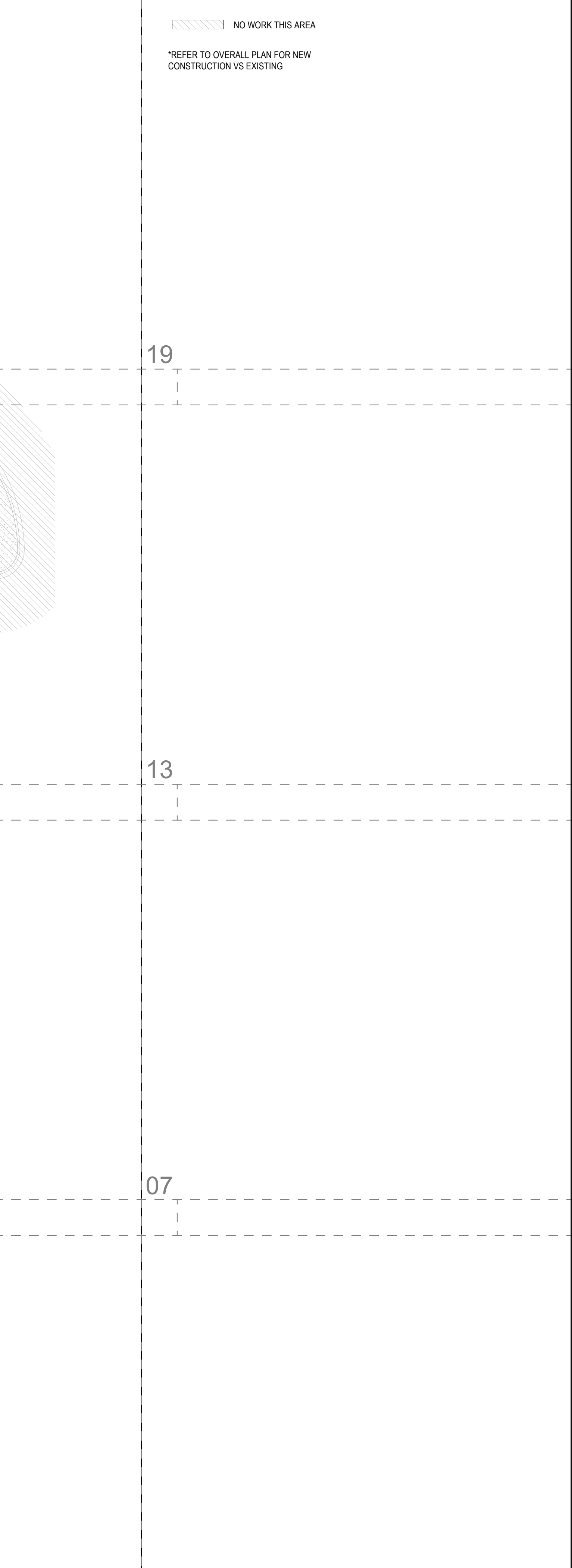

ARCHITECT: SAN ANTONIO, TX
 601 N. W. Loop 410, Suite 400
 San Antonio, TX 78216
 210-829-0573 F
 TX Firm: BR-1608

JOSE "JOE" CORREA JR AGRICULTURAL SCIENCE LAB

1101 W GRIFFIN PKWY MISSION, TX 78172

ISSUE FOR CONSTRUCTION

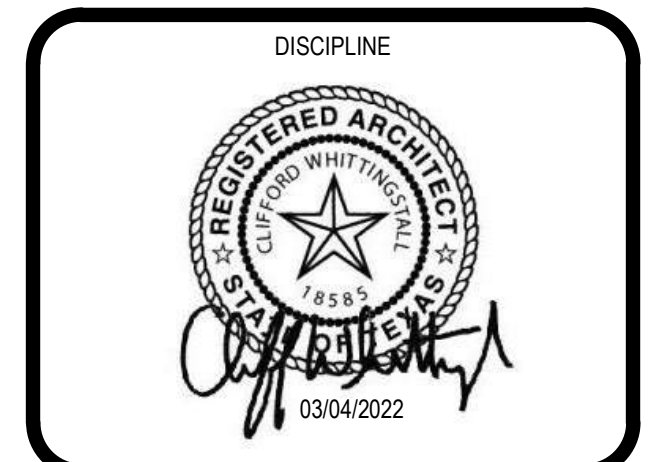
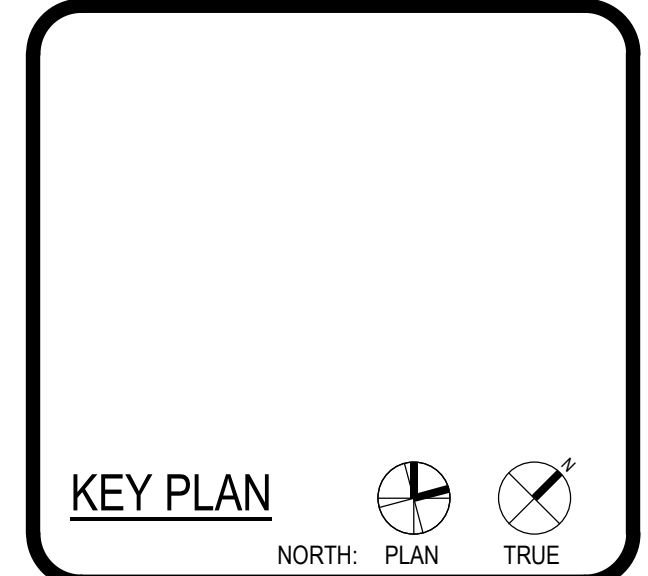

CLIENT: MISSION CISD		
DATE: 07/09/2015	PROJECT NUMBER: P2132500AR	
DRAWING HISTORY		
No.	Description	Date

ISSUE FOR CONSTRUCTION

BUILDING NUMBER

NEW CONSTRUCTION OVERALL PLAN

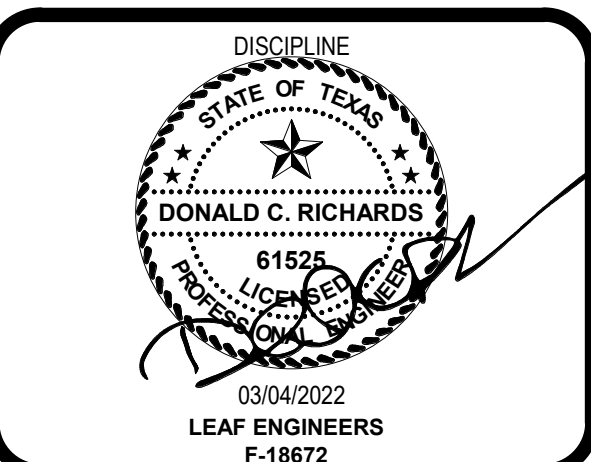

CLIENT MISSION CISD		
DATE 03/04/2022	PROJECT NUMBER P2132500AR	
DRAWING HISTORY		
No.	Description	Date

ISSUED FOR CONSTRUCTION
 BUILDING NUMBER

ELECTRICAL SYMBOLS AND ABBREVIATIONS



A	AMPERE	FAA	FIRE ALARM ANNUNCIATOR PANEL	NO	NUMBER OR NORMALLY OPEN
AC	ABOVE COUNTER	FCU	FAN COIL UNIT	NTS	NOT TO SCALE
AFF	ABOVE FINISHED FLOOR	GEN	GENERATOR	PNL	PANELBOARD
AFG	ABOVE FINISHED GRADE	GFI	GROUND FAULT INTERRUPTER	RECP	RECEPTACLE
AHU	AIR HANDLING UNIT	GND	GROUND	REQD	REQUIRED
ATS	AUTOMATIC TRANSFER SWITCH	GRS	GALVANIZED RIGID STEEL	RTU	ROOFTOP UNIT
C	CONDUIT	HID	HIGH INTENSITY DISCHARGE	TEL	TELEPHONE
CB	CIRCUIT BREAKER	HP	HORSEPOWER OR HEAT PUMP	TR	TAMPER RESISTANT
CCTV	CLOSED CIRCUIT TELEVISION	HPS	HIGH PRESSURE SODIUM	TRT	TRIPLE TUBE CF LAMP
CKT	CIRCUIT	IF	INSIDE FROSTED	TT	TWIN TUBE CF LAMP
CLK	CLOCK	KAIC	THOUSAND AMPERE INTERRUPTING CAPACITY	TV	TELEVISION
CTS	CIRCUIT TRANSFORMERS	KCMIL	THOUSAND CIRCULAR MILMETER	UH	UNIT HEATER
CU	CONDENSING UNIT	KVA	THOUSAND VOLT AMPERE	UON	UNLESS OTHERWISE NOTED
DISC SW	DISCONNECT SWITCH	MCB	MAIN CIRCUIT BREAKER	V	VOLT
EDF	ELECTRIC DRINKING FOUNTAIN	MH	METAL HALIDE	VA	VOLT AMPERE
EF	EXHAUST FAN	MLO	MAIN LUGS ONLY	WG	WIRE GUARD
ELEC	ELECTRICAL	MCC	MOTOR CONTROL CENTER	WP	WEATHER PROOF
EPO	EMERGENCY POWER OFF	NC	NORMALLY CLOSED	XFMR	TRANSFORMER
EQUIP	EQUIPMENT	NEC	NATIONAL ELECTRICAL CODE		
EWI	ELECTRIC WATER HEATER	NEMA	NATIONAL ELECTRICAL MANUFACTURERS ASS'N		
EXIST	EXISTING	NIC	NOT IN CONTRACT		
FACP	FIRE ALARM CONTROL PANEL	NL	NIGHT LIGHT		

NOTES:

- EVERY SYMBOL SHOWN MAY NOT APPEAR ON DRAWINGS.
- DASHED ELECTRICAL EQUIPMENT GENERALLY INDICATES EXISTING EQUIPMENT.
- LONG-SHORT-SHORT-LONG DASHING GENERALLY INDICATES MATCHLINE OR DEFINES AREA FOR SPECIAL NOTE.

CIRCUIT RELATED:

- LIGHTING OR POWER CIRCUIT(S). ARROW INDICATES HOME RUN. LONGER TICK(S) INDICATE NEUTRAL WIRE(S). SHORTER STRAIGHT TICK(S) INDICATE PHASE WIRE(S). SLANTED SHORTER TICK(S) INDICATE SWITCH LEG(S). DOT(S) INDICATE GROUNDING CONDUCTOR(S). DASHED WIRING (LONG-SHORT-LONG DASHES) INDICATES WIRING BELOW SLAB OR GRADE. DASHED WIRING (SERIES OF SHORT DASHES) INDICATES EXISTING WIRING. SLASH THROUGH ARROW INDICATES PARTIAL CIRCUIT. "D" ON HOMERUN ARROW INDICATES DEDICATED CIRCUIT. PROVIDE A SEPARATE NEUTRAL FOR EACH PHASE CONDUCTOR FOR ENTIRE LENGTH OF CIRCUIT FROM PANEL TO OUTLET. COUNT EACH NEUTRAL AS CURRENT-CARRYING AND GROUP A MAXIMUM OF SIX THHN/THWN CONDUCTORS IN A SINGLE RACEWAY. GROUNDING CONDUCTOR IS NOT COUNTED.
- JUNCTION BOX.
- POINT OF BRANCH CIRCUIT TAP FOR SEPARATELY SWITCHED FIXTURE GROUP. REFERENCE CATEGORY "B" LIGHTING SYMBOLS FOR FURTHER INFORMATION.
- GROUNDING ELECTRODE.

LIGHTING:

- LIGHTING FIXTURE. LETTER INDICATES TYPE.
- STRIP TYPE LIGHTING FIXTURE. LETTER INDICATES TYPE.
- LED DOWNLIGHT FIXTURE. LETTER INDICATES TYPE.
- WALL OR BRACKET MOUNTED FIXTURE OR DEVICE.
- EXIT LIGHT FIXTURE. LETTER INDICATES TYPE. PROVIDE CHEVRON DIRECTIONAL INDICATORS AS SHOWN ON DRAWINGS.
- WALL.
- CLG.

CONTROL:

- SWITCH. SMALL LETTER INDICATES FIXTURES CONTROLLED. "TY" INDICATES TAMPER RESISTANT. "P" INDICATES PLOT LIGHT. "WP" INDICATES WEATHERPROOF. "K" INDICATES KEY OPERATED. "MO" INDICATES SPDT MOMENTARY CONTACT. "VS" INDICATES VACANCY SENSOR. "OS" INDICATES OCCUPANCY SENSOR. "L" INDICATES DIGITAL LOW VOLTAGE ONLY SWITCH. "Z" INDICATES DPDT. "3" INDICATES 3-WAY. "4" INDICATES 4-WAY. "M" INDICATES MANUAL MOTOR STARTER. CIRCUIT DESIGNATION NEXT TO SWITCH INDICATES BRANCH CIRCUIT NUMBER.
- WALL BOX DIMMER SWITCH. "30" INDICATES 3-WAY DIMMER.
- DIGITAL TIME SWITCH.
- PHOTOELECTRIC CONTROL.
- EMERGENCY POWER OFF (EPO) PUSHBUTTON.
- PUSH BUTTON.
- WALL MOUNT OCCUPANCY SENSOR.
- DUAL TECHNOLOGY CEILING MOUNTED OCCUPANCY SENSOR.
- DUAL TECHNOLOGY CEILING MOUNTED DAYLIGHT SENSOR.
- CEILING MOUNTED HIGH CEILING OCCUPANCY SENSOR.
- DIGITAL LIGHTING ROOM CONTROLLER.
- DIGITAL LIGHTING NETWORK BRIDGE.

POWER OUTLETS:

- 20A-125V DUPLEX RECEPTACLE. "GF" INDICATES GROUND FAULT CIRCUIT INTERRUPTER RECEPTACLE.
- 20A-125V FOURPLEX RECEPTACLE.
- SPECIAL PURPOSE SINGLE POWER RECEPTACLE. RATED AS INDICATED IF NO RATING INDICATED. RECEPTACLE RATING SHALL MATCH BRANCH CIRCUIT OVERCURRENT PROTECTIVE DEVICE SIZE AND SHALL MEET REQUIREMENTS OF EQUIPMENT BEING CONNECTED. "C" INDICATES CLOCK OUTLET.
- SPECIAL PURPOSE RECEPTACLE.
- SAME AS DUPLEX RECEPTACLE EXCEPT ISOLATED GROUND TYPE RECEPTACLE.
- SAME AS FOURPLEX RECEPTACLE EXCEPT ISOLATED GROUND TYPE RECEPTACLE.
- AC INDICATES RECEPTACLE SHALL BE MOUNTED ABOVE COUNTER TOP. REFER TO ARCHITECT FOR EXACT HEIGHT ABOVE COUNTER.
- LC1-X CIRCUIT DESIGNATION NEXT TO RECEPTACLE DEVICES INDICATES BRANCH CIRCUIT NUMBER. RE: PANEL SCHEDULES FOR INFORMATION.
- WP "WP" INDICATES WEATHER PROOF DEVICE.

EQUIPMENT:

- A NOTATION INDICATING THE MOUNTING HEIGHT OF A DEVICE AS MEASURED FROM FINISHED FLOOR OR GRADE TO CENTER LINE OF DEVICE.
- MOTOR.
- DISCONNECT SWITCH. FRAME SIZE/FUSE SIZE/POLES AS INDICATED. "NF" INDICATES NON-FUSIBLE. NEMA 1 ENCLOSURE UNLESS OTHERWISE NOTED. PROVIDE FUSED BUSWAY PLUG WHEN SWITCH IS INDICATED ON BUSWAY. ALL DISCONNECT SWITCHES SHALL BE 30% UNLESS OTHERWISE NOTED.
- SINGLE CIRCUIT BREAKER IN INDIVIDUAL ENCLOSURE.
- MAGNETIC MOTOR CONTROLLER. NUMBER INDICATES NEMA SIZE. STARTER NEMA SIZE SHALL BE "NEMA 1" UNLESS OTHERWISE NOTED.
- COMBINATION DISCONNECT SWITCH/MOTOR CONTROLLER.
- CONTACTOR.
- PANELBOARD SWITCHBOARD/DP.
- TRANSFORMER.
- GROUNDING CONNECTION TO GROUNDING ELECTRODE AS DEFINED IN NEC ARTICLE 250.
- BELL. "WP" INDICATES OUTDOOR RATED.

LINE TYPES:

SITE PLAN:

- OVERHEAD ELECTRICAL LINES.
- UNDERGROUND ELECTRICAL PRIMARY.
- UNDERGROUND ELECTRICAL SECONDARY.

FLOOR PLANS:

- LIGHTING SWITCH LEG.
- LOW VOLTAGE WIRING.
- DAYLIGHT LIGHTING ZONE INDICATION.
- POWER SUPPLY LINES.

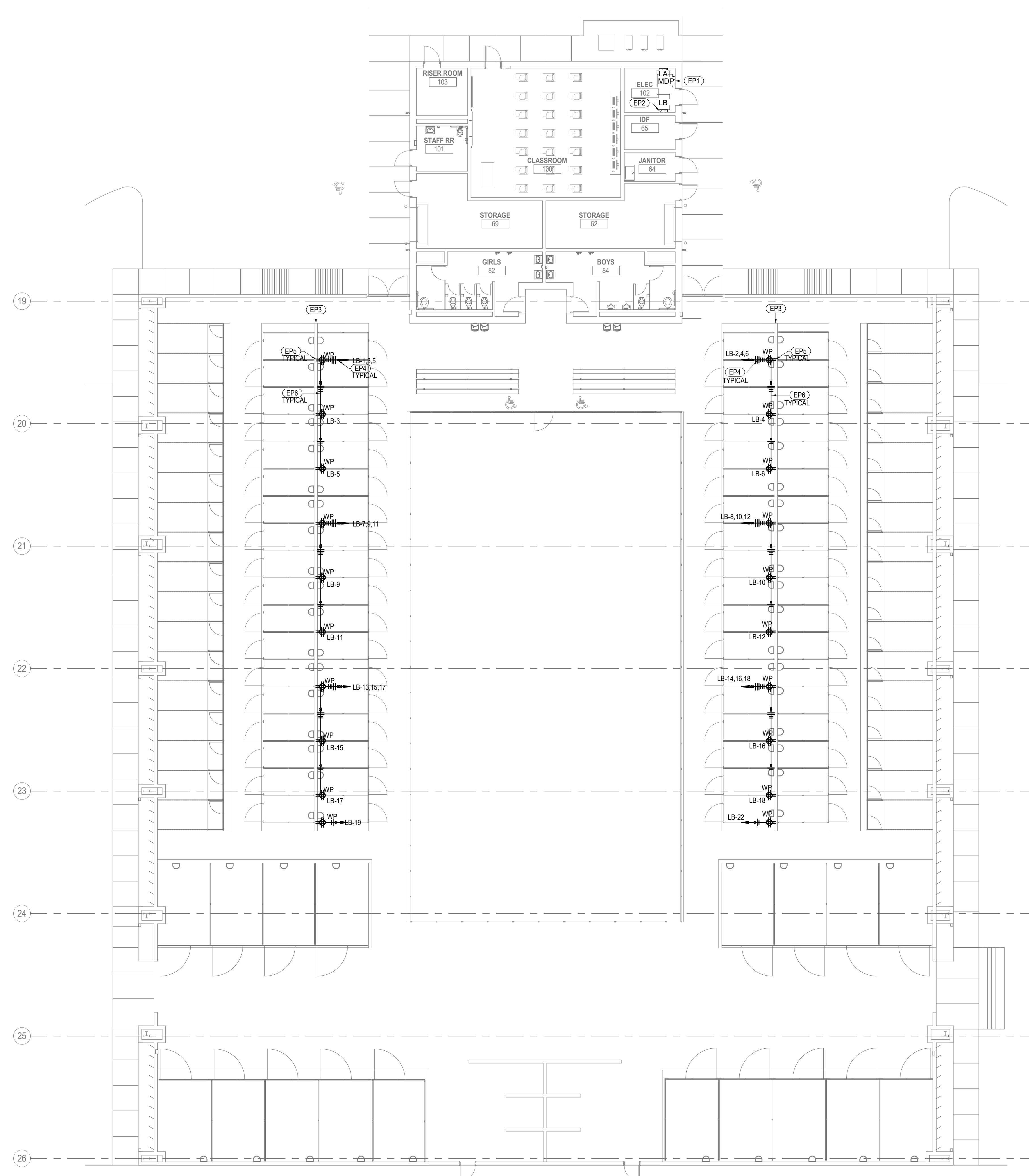

1 ELECTRICAL POWER PLAN
SCALE: 3/32" = 1'-0"

GENERAL NOTES - POWER PLAN

- COORDINATE ROUGH-IN LOCATION OF DEVICES WITH ARCHITECTURAL ELEVATIONS, DETAILS AND PLANS. INSTALL DEVICE BOXES FLUSH WITH FINISHED SURFACE.
- INSTALL A DEDICATED NEUTRAL FOR EACH 120V OR 277V BRANCH CIRCUIT.
- INSTALL ALL EXTERIOR RECEPTACLES WITH UNATTENDED "IN USE" TYPE METAL COVERS. COORDINATE EXACT ROUGH-IN LOCATIONS WITH ARCHITECT PRIOR TO INSTALLATION.

KEYED NOTES - POWER PLAN

- EP1 EXISTING ELECTRICAL PANEL MDP TO REMAIN. REPLACE EXISTING 80A SP CIRCUIT BREAKER FEEDING EXISTING LOAD CENTER WITH NEW 100A SP BREAKER IN SAME SPACE. NEW CIRCUIT BREAKER SHALL BE OF THE SAME MANUFACTURER AND COMPATIBLE WITH THE EXISTING PANEL AND SHALL HAVE AN AIC RATING TO MATCH THE EXISTING PANEL.
- EP2 REPLACE EXISTING LOAD CENTER AT THIS APPROXIMATE LOCATION WITH NEW PANEL LB. EXISTING PANEL REMOVED SHALL BE RETURNED TO OWNER. SERVE NEW PANEL LB FROM NEW 100A SP CIRCUIT BREAKER IN PANEL MDP.
- EP3 REMOVE ALL EXISTING ELECTRICAL DEVICES ON TOP OF WALL BETWEEN PENS IN THEIR ENTIRETY. REMOVE ALL ASSOCIATED CONDUIT AND BRANCH CIRCUIT WIRING IN ITS ENTIRETY BACK TO SOURCE.
- EP4 INSTALL 1" ALUMINUM RIGID CONDUIT WITH THREE 120V CIRCUITS IN EACH DROP FOR RECEPTACLES AS INDICATED. DO NOT INSTALL MORE THAN THREE CURRENT CARRYING CONDUCTORS AND NO CONDUCTORS OF THE SAME PHASE IN THE CONDUIT. EACH SHALL HAVE A DEDICATED NEUTRAL AND GROUND.
- EP5 INSTALL WEATHER PROOF QUAD OUTLET ON TOP OF WALL SUPPORTED BY HDG STEEL "C" CHANNEL SUPPORTS APOXY COATING. PROVIDE WITH UNATTENDED IN-USE DIE-CAST METAL COVER FOR 2-GAND BOX.
- EP6 INSTALL ALUMINUM RIGID CONDUIT ON TOP OF WALL SUPPORTED BY HDG STEEL "C" CHANNEL SUPPORTS WITH APOXY COATING IN ACCORDANCE WITH THE NEC BETWEEN OUTLET BOXES.



ARCHITECT
MCALLEN
3900 North 10th Street, Suite 810
McAllen, TX 78501
956-687-1330 P
956-687-1331 F
TX Firm BR 1688

ENGINEER
LEAF ENGINEERS
1101 W Griffin Pkwy, Mission, TX 78572
ISSUED FOR CONSTRUCTION

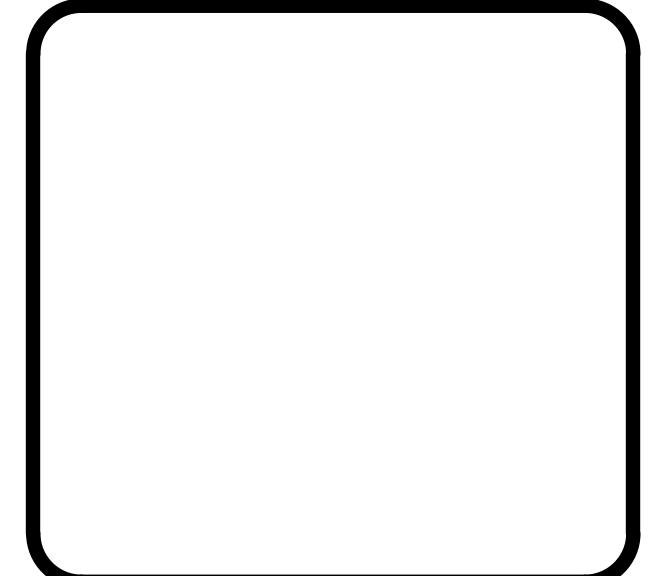

CLIENT
MISSION CISD
DATE
03/04/2022
PROJECT NUMBER
P2132500AR

DRAWING HISTORY		
No.	Description	Date

ISSUED FOR CONSTRUCTION
BUILDING NUMBER

ELECTRICAL POWER PLAN



601 N.W. LOOP 410, SUITE 450
SAN ANTONIO, TX 78216
210-638-7200
TX Firm: F-18672

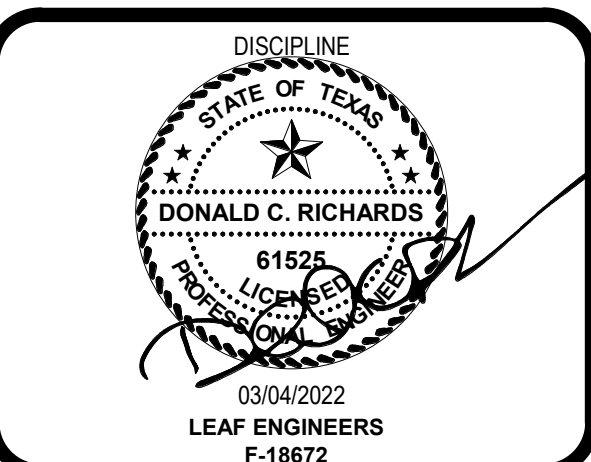
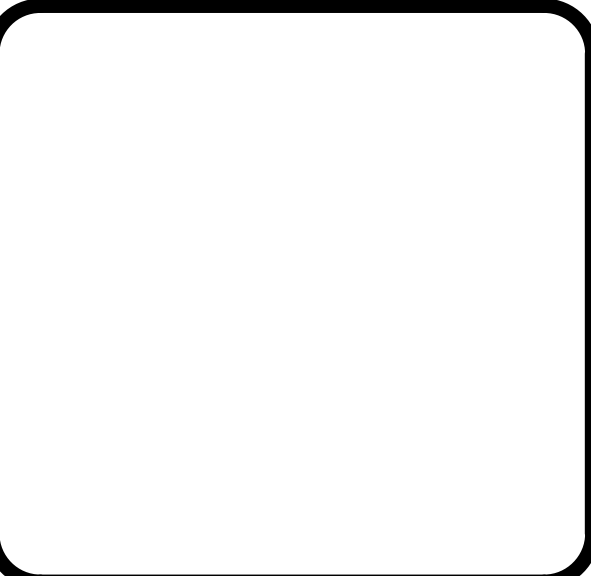

CLIENT: MISSION CISD		
DATE: 03/04/2022	PROJECT NUMBER: P2132500AR	
DRAWING HISTORY		
No.	Description	Date

ISSUED FOR CONSTRUCTION
 BUILDING NUMBER

ELECTRICAL ONE
 LINE DIAGRAMS &
 SCHEDULES

ELECTRICAL KEYED NOTES:

- EXISTING OVERHEAD ELECTRIC PRIMARY.
- EXISTING PANEL MDP TO REMAIN.
- INSTALL NEW 100A 3P CIRCUIT BREAKER IN PANEL MDP AS INDICATED. REFER TO DRAWING E2.01 FOR ADDITIONAL INFORMATION.
- INSTALL NEW FEEDER TO PANEL LB CONSISTING OF 4 #3, #9GND, 1 1/4" C.
- NEW PANEL LB. REFER TO DRAWING E2.01 FOR LOCATION.

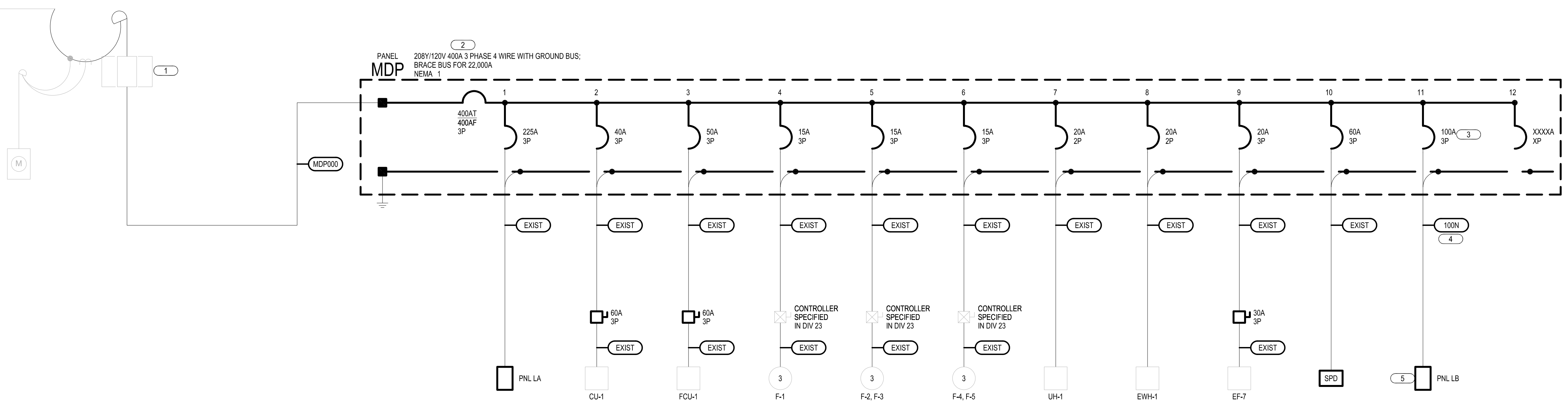

1 ELECTRICAL RISER DIAGRAM
 SCALE: NONE

PANELBOARD MDP											
VOLTAGE: 208Y/120V 3 PHASE 4 WIRE						LOCATION: ROOM 102					
400A MAIN BREAKER						MOUNTING: SURFACE					
BUSES: MAIN - 400 A, NEUTRAL - 100%; EQUIPMENT GROUND						Isc = 15,000 A RMS SYM AVAILABLE					
VAL	VAR	VAR	LOAD	BKR	CKT	CKT	BKR	LOAD	VAL	VAR	VAR
6541	3960	10000	PANEL LA	Z253	A	2	403	CU-1	0	0	2222
6096	6550	8693			B	2			0	0	2222
5024	4140	10176			C	2			0	0	2222
0	0	5236	FCU-1	503	A	15/3	F-1		0	0	1321
0	0	5236			B	4			0	0	1321
0	0	5236			C	4			0	0	1321
0	0	721	F-4, F-5	15/3	A	15/3	F-2, F-3		0	0	721
0	0	721			B	6			0	0	721
0	0	721			C	6			0	0	721
0	0	1500	UH-1	202	A	202	EWH-1		0	0	1500
0	0	1500			B	8			0	0	1500
0	0	1321	EF-7	203	A	603	SPD		0	0	
0	0	1321			B	10			0	0	
0	0	1321			C	10			0	0	
0	2520	0	PANEL LB	1003	A	15/3	SPARE		0	0	
0	2520	0			B	12			0	0	
0	2160	0			C	12			0	0	
VAL (LIGHTING)			17661	CONNECTED			22076	DEMAND			
VAR (RECEPTACLES)			20880	CONNECTED			15440	DEMAND			
VA (OTHER)			69833	CONNECTED			69833	DEMAND			
VA TOTAL			108374	CONNECTED			107349	DEMAND			
AMPS: TOTAL			301	CONNECTED			298	DEMAND			
L	R	O	TOTAL								
6541	6480	24745	VA CONNECTED TO A PHASE	37799	VA =	315	AMPS CONNECTED TO A PHASE @ 120 VOLTS				
6096	6100	23370	VA CONNECTED TO B PHASE	37666	VA =	313	AMPS CONNECTED TO B PHASE @ 120 VOLTS				
5024	6300	21718	VA CONNECTED TO C PHASE	33042	VA =	275	AMPS CONNECTED TO C PHASE @ 120 VOLTS				
17661	20880	69833	TOTAL	108374	VA						

PANELBOARD LB											
VOLTAGE: 208Y/120V 3 PHASE 4 WIRE						LOCATION: ROOM 102					
100 A MAIN LUGS ONLY						MOUNTING: SURFACE					
BUSES: MAIN - 100 A, NEUTRAL - 100%; EQUIPMENT GROUND						Isc = 10,000 A RMS SYM AVAILABLE					
VAL	VAR	VAR	LOAD	BKR	CKT	CKT	BKR	LOAD	VAL	VAR	VAR
0	360	0	PEN RECEPTACLES	20/1	1	A	2	20/1	PEN RECEPTACLES	0	360
0	360	0	PEN RECEPTACLES	20/1	3	B	4	20/1	PEN RECEPTACLES	0	360
0	360	0	PEN RECEPTACLES	20/1	5	C	6	20/1	PEN RECEPTACLES	0	360
0	360	0	PEN RECEPTACLES	20/1	7	A	8	20/1	PEN RECEPTACLES	0	360
0	360	0	PEN RECEPTACLES	20/1	9	B	10	20/1	PEN RECEPTACLES	0	360
0	360	0	PEN RECEPTACLES	20/1	11	C	12	20/1	PEN RECEPTACLES	0	360
0	360	0	PEN RECEPTACLES	20/1	13	A	14	20/1	PEN RECEPTACLES	0	360
0	360	0	PEN RECEPTACLES	20/1	15	B	16	20/1	PEN RECEPTACLES	0	360
0	360	0	PEN RECEPTACLES	20/1	17	C	18	20/1	PEN RECEPTACLES	0	360
0	360	0	PEN RECEPTACLES	20/1	19	A	20	20/1	SPARE	0	0
0	0	0	SPARE	20/1	21	B	22	20/1	PEN RECEPTACLES	0	360
0	0	0	SPARE	20/1	23	C	24	20/1	SPARE	0	0
0	0	0	SPARE	20/1	25	A	26	20/1	SPARE	0	0
0	0	0	SPARE	20/1	27	B	28	20/1	SPARE	0	0
0	0	0	SPARE	20/1	29	C	30	20/1	SPARE	0	0
0	0	0	SPARE	20/1	31	A	32	20/1	SPARE	0	0
0	0	0	SPARE	20/1	33	B	34	20/1	SPARE	0	0
0	0	0	SPARE	20/1	35	C	36	20/1	SPARE	0	0
0	0	0	SPARE	20/1	37	A	38	20/1	SPARE	0	0
0	0	0	SPARE	20/1	39	B	40	20/1	SPARE	0	0
0	0	0	SPARE	20/1	41	C	42	20/1	SPARE	0	0
VAL (LIGHTING)			0	CONNECTED			0	DEMAND			
VAR (RECEPTACLES)			7200	CONNECTED			7200	DEMAND			
VA (OTHER)			0	CONNECTED			0	DEMAND			
VA TOTAL			7200	CONNECTED			7200	DEMAND			
AMPS: TOTAL			20	CONNECTED			20	DEMAND			
L	R	O	TOTAL								
0	2520	0	VA CONNECTED TO A PHASE	2520	VA =	21	AMPS CONNECTED TO A PHASE @ 120 VOLTS				
0	2520	0	VA CONNECTED TO B PHASE	2520	VA =	21	AMPS CONNECTED TO B PHASE @ 120 VOLTS				
0	2160	0	VA CONNECTED TO C PHASE	2160	VA =	18	AMPS CONNECTED TO C PHASE @ 120 VOLTS				
0	7200	0	TOTAL	7200	VA						

LOAD ANALYSIS			
EXISTING LOADS			
LIGHTING -			
RECEPTACLES -	76 EA X 180 VA/EA =	13680 VA	X 1.00 = 13680 VA
<10,000 VA		10000 VA	X 1.00 = 10000 VA
>10,000 VA		3680 VA	X 0.50 = 1840 VA
AIR CONDITIONING -		11477 VA	X 1.00 = 11477 VA
HEATING -		18708 VA	X 1.00 = 18708 VA
OTHER -		39648 VA	X 1.00 = 39648 VA
NEW LOADS			
RECEPTACLES (QUADS) -	20 EA X 360 VA/EA =	7200 VA	X 1.00 = 7200 VA
		NET CALCULATED DEMAND =	108534 VA
		@ 120/208V 3 PH =	296 A
THE EXISTING SERVICE CONSISTING OF TWO SET OF #3/0 (200A) PER PHASE AND NEUTRAL IS ADEQUATE FOR THE SERVICE			

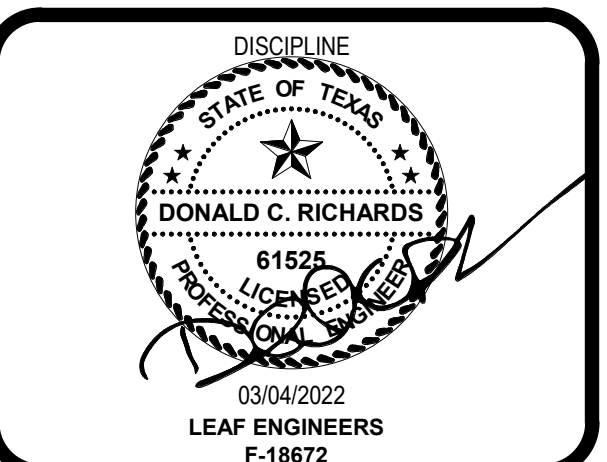

CLIENT MISSION CISD		
DATE 03/04/2022	PROJECT NUMBER P2132500AR	
DRAWING HISTORY		
No.	Description	Date
ISSUED FOR CONSTRUCTION		
BUILDING NUMBER		

PLUMBING SYMBOLS AND ABBREVIATIONS

PLUMBING ABBREVIATION SCHEDULE

NOTES: 1. ALL ABBREVIATIONS MAY NOT BE USED ON THESE DRAWINGS.

AAP	AREA ALARM PANEL	MS	MOP SINK
AAV	AUTOMATIC AIR VENT	N.C.	NORMALLY CLOSED
A.F.F.	ABOVE FINISHED FLOOR	NIC	NOT IN CONTRACT
AP	ACCESS PANEL	N.O.	NORMALLY OPEN
B.F.F.	BELOW FINISHED FLOOR	O.F./C.I.	OWNER FURNISHED/CONTRACTOR INSTALLED
BFP	BACKFLOW PREVENTER	O.F./O.I.	OWNER FURNISHED/OWNER INSTALLED
BOB	BOTTOM OF BEAM	OFD	OVERFLOW DRAIN
BOP	BOTTOM OF PIPE	PH	PHASE
BTUH	BRITISH THERMAL UNITS PER HOUR	PIV	POST INDICATOR VALVE
C/C	CUT AND CAP	PRV	PRESSURE REDUCING VALVE
CFH	CUBIC FEET PER HOUR	RD	ROOF DRAIN
CFS	CUBIC FEET PER SECOND	RE	REFER TO
CI	CAST IRON	R.I.C.	ROUGH-IN AND CONNECT
CLG	CEILING	RO	REVERSE OSMOSIS
CO	CLEANOUT	RPBFP	REDUCED PRESSURE BACKFLOW PREVENTER
CONN	CONNECTION	RPM	REVOLUTIONS PER MINUTE
CONT.	CONTINUATION	RVB	REFRIGERATOR VALVE BOX
DF	DRINKING FOUNTAIN	SD	STORM DRAIN
DPV	DRY PIPE VALVE	S.F.	SQUARE FEET
DWG.	DRAWING	SIA	SIAMSESE
EA	EACH	SK	SINK
EDF	ELECTRIC DRINKING FOUNTAIN	T.O.P.	TOP OF PIPE
FCO	FLOOR CLEANOUT	TP	TRAP PRIMER
FD	FLOOR DRAIN	TYP	TYPICAL
FDV	FIRE DEPARTMENT VALVE	U	URINAL
F.F.	FINISHED FLOOR	UF	UNDERFLOOR
FHC	FIRE HOSE CABINET	UIS	UNDERSLAB
F.L.	FLOW LINE	VAC BRKR.	VACUUM BREAKER
FS	FLOOR SINK	VCT	VITRIFIED CLAY TILE
FT	FEET	VTR	VENT THRU ROOF
FU	FIXTURE UNITS	WC	WATER CLOSET
GC	GENERAL CONTRACTOR	WCO	WALL CLEANOUT
GPH	GALLONS PER HOUR	WH	WALL HYDRANT
GPM	GALLONS PER MINUTE	WMB	WASHING MACHINE BOX
HB	HOSE BIBB	YH	YARD HYDRANT
HP	HORSEPOWER	ZV	ZONE VALVE
I.E.	INVERT ELEVATION	(A)	ITEM NOTED TO BE ABANDONED
KW	KILOWATTS	(D)	ITEM NOTED TO BE DEMOLISHED
LAV	LAVATORY	(E)	EXISTING ITEM
MAP	MASTER ALARM PANEL	(N)	NEW ITEM
MECH	MECHANICAL	(R)	ITEM NOTED TO BE RELOCATED
MH	MANHOLE		

PLUMBING TESTING:

- ALL EQUIPMENT AND/OR SYSTEMS NOTED ON THE DRAWINGS TO REMAIN SHALL BE INSPECTED AND TESTED ON SITE TO CERTIFY WORKING CONDITION. A WRITTEN REPORT ON THE CONDITION OF ALL EQUIPMENT TO REMAIN, INCLUDING A COPY OF THE TEST RESULTS AND RECOMMENDED REMEDIAL ACTIONS AND COSTS SHALL BE MADE BY THIS CONTRACTOR TO THE ARCHITECT/ENGINEER FOR REVIEW.
- PIPE COVER AND BACKFILLING:
 - AFTER HYDROSTATIC TEST, EVENLY BACKFILL ENTIRE TRENCH WIDTH BY HAND PLACING BACKFILL MATERIAL AND HAND TAMPING IN FOUR (4) INCHES COMPACTED LAYERS TO 12 INCHES MINIMUM COVER OVER TOP OF JACKET. COMPACT TO 95 PERCENT MAXIMUM DENSITY.
 - EVENLY AND CONTINUOUSLY BACKFILL REMAINING TRENCH DEPTH IN UNIFORM LAYERS WITH BACKFILL MATERIAL.
 - DO NOT USE WHEELED OR TRACKED VEHICLES FOR TAMPING.
- PRESSURE TEST ALL DOMESTIC WATER PIPING. AFTER INSTALLATION AND PRIOR TO BACKFILL OR COVER UP, RISE PIPING SYSTEM OF PARTICULATE CONTAMINANTS, CAP AND SUBJECT TO STATIC WATER PRESSURE OF 125 PSIG FOR FOUR (4) HOURS. REPAIR LEAKS AND DEFECTS AND RE-TEST ANY PORTION OF PIPING SYSTEM THAT FAILS. PROVIDE WRITTEN TEST REPORT INCLUDING DATE AND TIME OF TEST, PASS OR FAIL INDICATION, SUMMARY OF REMEDIAL WORK REQUIRED AND DATE AND TIME OF EACH RE-TEST.
- PRIOR TO COVER UP, WATER PIPE, SANITARY PIPE, AND GAS PIPING SHALL BE PRESSURE TESTED. TESTS SHALL BE WITNESSED BY CONSULTANT AND OWNER. NOTIFY OWNER 48 HOURS PRIOR TO TEST. TEST SHALL BE WITNESSED BY CLIENT PLUMBING TECHNICIAN.
- UPON COMPLETION OF THE SANITARY PIPING SYSTEM, THE CONTRACTOR SHALL NOTIFY ENGINEER AND OWNER TO OBSERVE A SMOKE TEST OF THE SYSTEM. SMOKE TESTING SHALL BE PERFORMED ON SANITARY PIPING SYSTEM TWICE DURING CONSTRUCTION.
- ACID WASTE PIPING SYSTEMS:
 - WATER TEST SHALL BE APPLIED TO THESE DRAINAGE SYSTEMS EITHER IN THEIR ENTIRETY OR IN SECTIONS AS REQUIRED. AFTER ROUGH PIPING HAS BEEN INSTALLED, IF THE SYSTEM IS TESTED IN SECTIONS, EACH OPENING IN THE SECTION UNDER TEST. ALL SECTIONS SHALL BE TESTED WITH A MINIMUM OF 10 FEET HEAD OF WATER. IN TESTING SUCCESSIVE SECTIONS AT LEAST THE UPPER 10 FEET OF THE NEXT PRECEDING SECTION SHALL BE TESTED SO THAT NO JOINT OF PIPING IN THE BUILDING EXCEPT THE UPPERMOST 10 FEET OF THE SYSTEM SHALL BE SUBMITTED TO A TEST OF LESS THAN A 10 FOOT OF HEAD WATER. THE WATER SHALL BE KEPT IN THE SYSTEM FOR AT LEAST 200 MINUTES BEFORE INSPECTIONS STARTS; THE SYSTEM SHALL THEN BE MADE TIGHT AT ALL POINTS.
 - ANY POINTS OF THE DRAINAGE SYSTEMS TO BE TESTED WITH AIR INSTEAD OF WATER SHALL BE MADE BY ATTACHING AN AIR COMPRESSOR TESTING APPARATUS TO ANY SUITABLE OPENING AND AFTER CLOSING ALL OTHER LETS OR OUTLETS, FORCING AIR INTO THE SYSTEM UNTIL THERE IS A MINIMUM GAUGE PRESSURE OF 5 PSI. THIS PRESSURE SHALL BE HELD WITHOUT THE INTRODUCTION OF ADDITIONAL AIR FOR A PERIOD OF AT LEAST 30 MINUTES.
- EXTERIOR CONNECTIONS SHALL BE TESTED AS PART OF THE INTERIOR SYSTEMS.
- ADDITIONAL TESTS:
 - PROVIDE ALL ADDITIONAL TEST SUCH AS SMOKE OR PRESSURE TESTS AS REQUIRED BY THE REGULATIONS OR AS DIRECTED BY AUTHORITIES MAKING THE INSPECTION.
 - PROVIDE FOR ANY REPEATED TEST AS DIRECTED BY THE OWNERS REPRESENTATIVE, TO MAKE ALL SYSTEMS TIGHT AS REQUIRED.
 - VISUAL INSPECTIONS OF JOINTS, VALVES, ETC. SHALL BE MADE AS DIRECTED BY THE ENGINEER.
 - PRESSURE TEST NATURAL GAS PIPING IN ACCORDANCE WITH NFPA 54. PRESSURE TEST PRIOR TO BACKFILL, MINIMUM 50PSI FOR 24 HOURS.

GENERAL NOTES:

- THE PLUMBING WORK SHALL BE PERFORMED IN STRICT ACCORDANCE WITH THE 2015 IPC & 2015 IFGC AS WELL AS ALL LOCAL REGULATIONS THAT MAY APPLY. IN CASE OF CONFLICT BETWEEN THE CONTRACT DOCUMENTS AND A GOVERNING CODE OR ORDINANCE, THE MORE STRINGENT STANDARD SHALL APPLY.
- ALL PLUMBING WORK SHALL BE COORDINATED WITH ALL OTHER TRADES BEFORE PROCEEDING WITH THE INSTALLATION.
- INVERT ELEVATIONS AND EXACT LOCATIONS OF ALL EXISTING UTILITIES SHALL BE CHECKED BEFORE PROCEEDING WITH THE NEW WORK.
- NO CHANGES ARE TO BE MADE IN PLUMBING LAYOUT WITHOUT WRITTEN PERMISSION BY THE ARCHITECT OR ENGINEER.
- NO PIPING SHALL RUN EXPOSED IN FINISHED AREAS.
- ROUGH-IN DIMENSIONS OF TOILET FIXTURES MUST BE COORDINATED WITH THE GENERAL CONTRACTOR.
- PROVIDE SHUTOFF VALVES FOR WATER HEATER BRANCH. PROVIDE DIELECTRIC FITTINGS OR COUPLINGS WHEREVER DISSIMILAR METALS ARE JOINED.
- PROVIDE SHUTOFF VALVES AT EACH FIXTURE ON HOT AND COLD WATER SUPPLY PIPES.
- ALL ACCESS PANELS SHALL BE BY GENERAL CONTRACTOR. PLUMBING CONTRACTOR SHALL BE RESPONSIBLE FOR THEIR LOCATION.
- INSTALL ALL REQUIRED CLEANOUTS TO CLEAR EQUIPMENT AND FIXTURES.
- ALL WORK SHALL BE PROPERLY TESTED, BALANCED, AND CLEANED AND DISINFECTED. PROVIDE A ONE YEAR WARRANTY FROM DATE OF FINAL INSPECTION ON ALL PARTS AND LABOR.
- ALL PLUMBING FIXTURES SPECIFIED ARE FOR INFORMATION ONLY. EQUAL EQUIPMENT MAY BE INSTALLED SECURING FIRST THE ENGINEER'S APPROVAL.
- PITCH ALL WASTE AND SOIL PIPING AT MAXIMUM SLOPE POSSIBLE, BUT NOT LESS THAN 1/4" PER FOOT FOR PIPING 3" AND UNDER AND NO LESS THAN 1/8" FOR PIPING 4" AND GREATER.
- PROVIDE ALL PIPE OPENINGS THROUGH PARTITIONS WITH PIPE SLEEVES. PENETRATING FIRE RATED PARTITIONS, THE SPACE BETWEEN THE PIPE AND THE SLEEVE SHALL BE SEALED WITH FIRE STOPPING MATERIAL.
- ANY UNAUTHORIZED CHANGES TO THE EQUIPMENT DESIGN OR INSTALLATION OF THE PLUMBING SYSTEMS WITHOUT THE EXPRESSED WRITTEN CONSENT OF THE ENGINEER IS UNACCEPTABLE AND GROUNDS FOR REMOVAL OF ALL LIABILITY OF THE ARCHITECT/ENGINEER FOR THE REVISED DESIGN.
- PROVIDE CONDENSATE DRAIN FROM ROOF MOUNTED EQUIPMENT TO OPEN SITE DRAIN OR AS SHOWN.
- ALL PIPING MATERIAL SHALL BE OF DOMESTIC MANUFACTURE AND SHALL COMPLY WITH THE BUY AMERICAN ACT.

PLUMBING SYMBOLS LEGEND

NOTES: 1. ALL SYMBOLS MAY NOT BE USED ON THESE DRAWINGS.

SYMBOL	ABV.	DESCRIPTION
AW	AW	ACID WASTE
AV	AV	AIR VENT
B	B	BUTANE
CDWR	CDWR	CHILLED DRINKING WATER RETURN
CDWS	CDWS	CHILLED DRINKING WATER SUPPLY
D	D	DRAIN PIPING
DSP	DSP	DRY SPRINKLER PIPE
F	F	FIRE LINE
FOR	FOR	FUEL OIL RETURN
FOS	FOS	FUEL OIL SUPPLY
FOV	FOV	FUEL OIL VENT
G	G	NATURAL GAS PIPING
GW	GW	GREASE WASTE ABOVE SLAB
GW	GW	GREASE WASTE BELOW SLAB
OSD	OSD	STORM OVER FLOW DRAIN
P	P	PROPANE GAS PIPING
PSS	PSS	PUMPED SANITARY SEWER
PSD	PSD	PUMPED STORM SEWER
SD	SD	STORM DRAIN ABOVE SLAB
SD	SD	STORM DRAIN BELOW SLAB
SP	SP	SPRINKLER LINE
SS	SS	SANITARY SEWER ABOVE SLAB
SS	SS	SANITARY SEWER BELOW SLAB
SV	SV	SANITARY VENT
CW	CW	COLD WATER
HW	HW	HOT WATER
HWR	HWR	HOT WATER RETURN
		DIRECTION OF FLOW
		DIRECTION OF SLOPE DOWN
		DROP IN PIPE
		RISE IN PIPE
		GATE VALVE
		BALL VALVE
		CHECK VALVE
		SUPERVISED VALVE WITH FLOW SWITCH
		SUPERVISED VALVE IN VERTICAL
		FLUG VALVE / GAS COCK
		BUTTERFLY VALVE
		BALANCING VALVE
		PIPE UNION
		PRESSURE CONTROL VALVE
		3-WAY VALVE
		SOLENOID VALVE
		FLOW SWITCH
		PRESSURE GAUGE WITH GAUGE COCK
		THERMOMETER
		ROOF DRAIN / OVERFLOW DRAIN
		FLOOR DRAIN
		FLOOR SINK
		T & P RELIEF VALVE
		STRAINER
CO	CO	END OF LINE CLEANOUT
FCO	FCO	FLOOR CLEANOUT
WCO	WCO	WALL CLEANOUT
		CAP
		FLEXIBLE CONNECTION
(E)	(E)	NEW CONNECTION TO EXISTING
(E)	(E)	EXISTING RISER

PLUMBING PIPING MATERIAL SCHEDULE

SYSTEM	BELOW GRADE	ABOVE GRADE
DOMESTIC WATER PIPING	TYPE K COPPER	REFER TO SPECS

DRAWING REFERENCE KEY

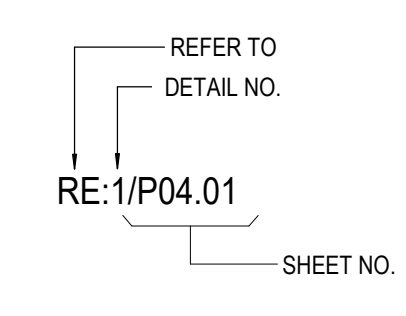

601 N.W. LOOP 410, SUITE 450
SAN ANTONIO, TX 78216
210-638-7200
TX Firm: F-18672

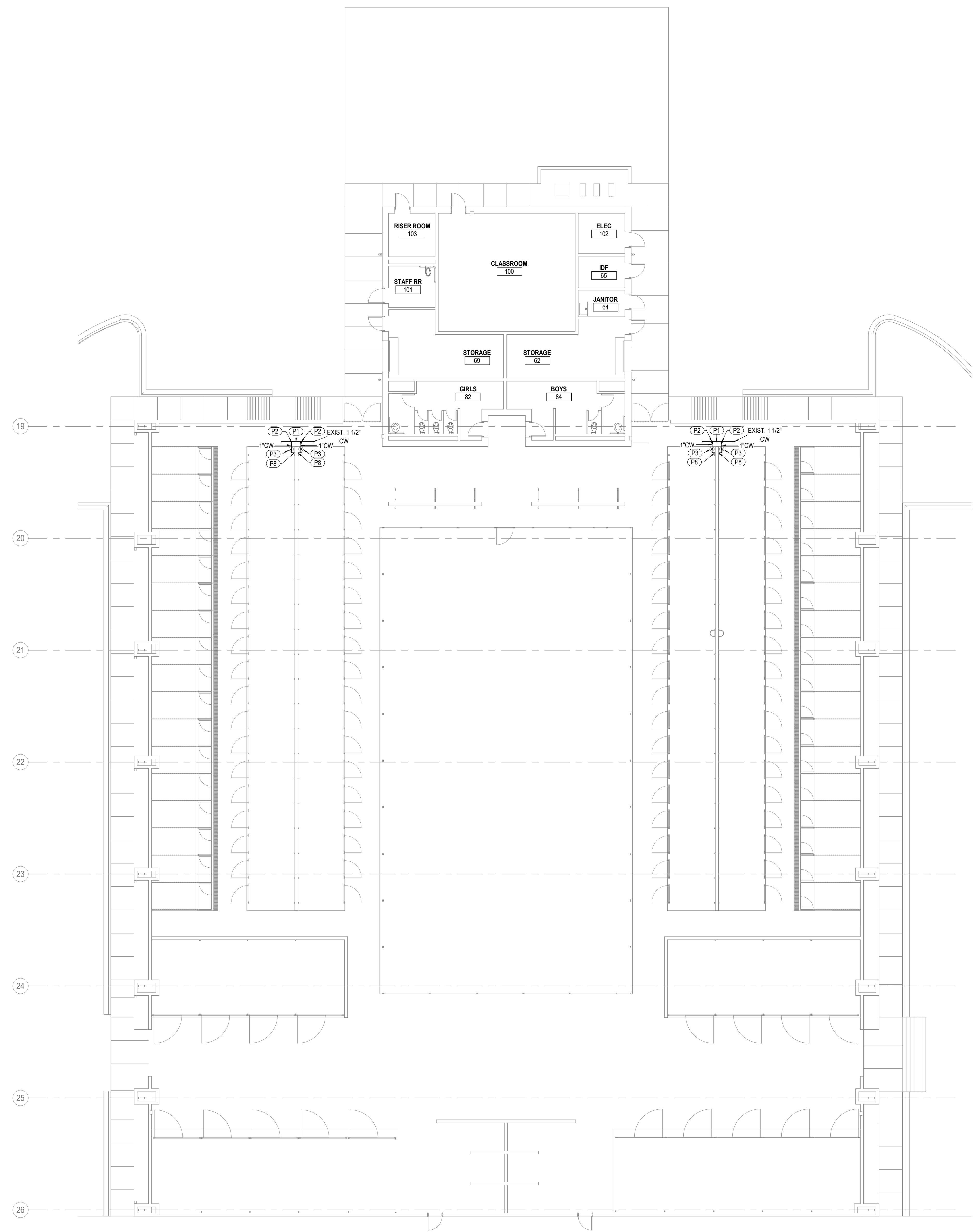

GENERAL NOTES - PLUMBING PLAN

1. THE CONTRACTOR SHALL COMPLY WITH ALL AUTHORITIES HAVING JURISDICTION.
2. ALL FINAL CONNECTIONS TO FIXTURES AND EQUIPMENT SHALL BE MADE BY THE PLUMBING CONTRACTOR.
3. ALL PLUMBING PIPING SHALL BE COORDINATED WITH ALL OTHER TRADES PRIOR TO ANY INSTALLATION OF ALL PLUMBING FIXTURES AND EQUIPMENT BY THE PLUMBING CONTRACTOR.
4. ALL FLOOR DRAINS AND FLOOR SINKS SHOWN ON THIS DRAWING SHALL BE COORDINATED WITH ALL OTHER TRADES PRIOR TO INSTALLATION.
5. REFER TO ARCHITECTURAL DRAWING FOR EXACT LOCATIONS OF FIXTURES, EQUIPMENT, ETC. DO NOT SCALE FROM PLUMBING DRAWINGS.
6. ALL WALL CLEAN-OUTS SHALL BE ACCESSIBLE BY AN ACCESS PANEL.
7. PROVIDE A DOUBLE EXTERIOR CLEAN-OUT (DFCO) ON ALL SANITARY LINES EXITING THE BUILDING.
8. ALL FLOOR DRAINS AND FLOOR SINKS SHALL BE PROVIDED WITH A TRAP PRIMER.
9. FIXTURES DESIGNATED AS ADA ACCESSIBLE BY ARCHITECT SHALL BE INSTALLED AT ADA ACCESSIBLE HEIGHT PER ARCHITECTURAL DETAILS.
10. ALL DOMESTIC COLD AND HOT WATER TAKE-OFFS SHALL HAVE AN ISOLATION SHUT-OFF VALVE.
11. FLOOR DRAINS AND FLOOR SINKS IN MECHANICAL ROOMS SHALL BE SET NOT LESS THAN 6" FROM HOUSEKEEPING PADS. RE: MECHANICAL DRAWINGS. DO NOT PLACE ON, OR IN, HOUSEKEEPING PAD, OR UNDERNEATH EQUIPMENT.
12. CONTRACTOR SHALL DEWATER ANY AREA AT OR BELOW GRADE PRIOR TO SETTING EQUIPMENT.
13. CONTRACTOR SHALL PLACE A TRAP PRIMER, TP-1, AND A HOSE BIBB, HB-2, IN ALL MECHANICAL ROOMS.
14. PROVIDE A HOSE-BIBB WITH WHEEL HANDLE IN ALL MECHANICAL ROOMS, HB-2.
15. ANY AND ALL WATER PIPING EXPOSED TO OUTSIDE ELEMENTS SHALL BE INSULATED AND HEAT TRACED TO PREVENT FREEZING.
16. ALL SANITARY 3" OR ABOVE SHALL BE INSPECTED BY A CAMERA PRIOR TO SUBSTANTIAL COMPLETION.

KEYED NOTES - PLUMBING PLAN

- P1 EXISTING 1 1/2" COLD WATER LINE BELOW FINISHED FLOOR.
- P2 CONTRACTOR TO SAW CUT EXISTING FLOOR AND LOCATE EXISTING WATER LINE AND CONNECT NEW 1" LINE BELOW GRADE AS SHOWN ON PLAN.
- P3 PROVIDE LINE SIZE CUT OFF VALVE. PROVIDE CAST IRON VALVE BOX WITH COVER.
- P8 COLD WATER UP FROM BELOW GRADE. SIZE AS NOTED.

JOSE "JOE" CORREA JR AGRICULTURAL
SCIENCE LAB

1101 W Griffin Pkwy, Mission, TX 78572
ISSUED FOR CONSTRUCTION

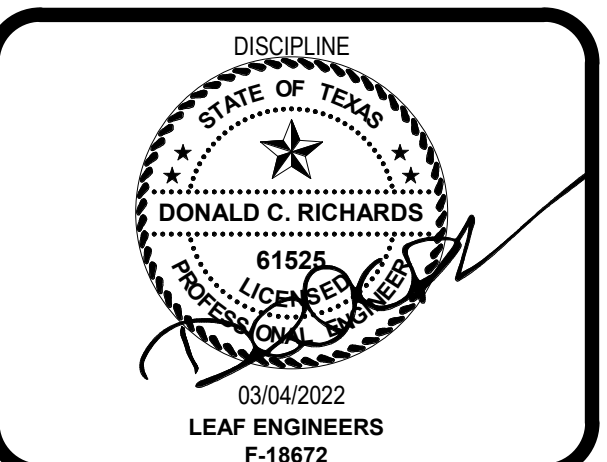

CLIENT: MISSION CISD		
DATE: 03/04/2022	PROJECT NUMBER: P2132500AR	
DRAWING HISTORY		
No.	Description	Date

ISSUED FOR CONSTRUCTION
BUILDING NUMBER

UNDERFLOOR -
PLUMBING PLAN

1 UNDERFLOOR PLUMBING PLAN
SCALE: 3/32" = 1'-0"



601 N.W. LOOP 410, SUITE 460
SAN ANTONIO, TX 78216
210-638-7200
TX Firm: F-18672

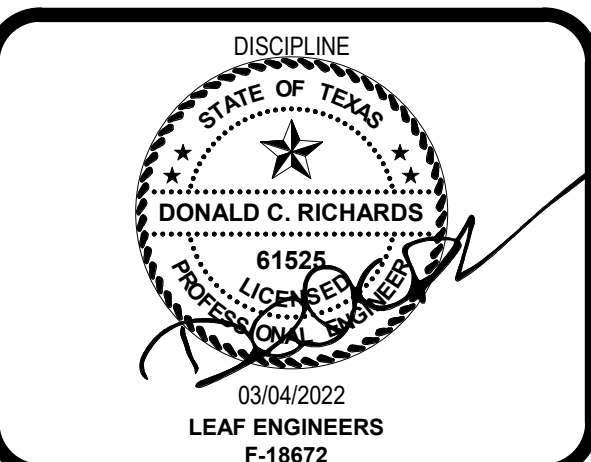
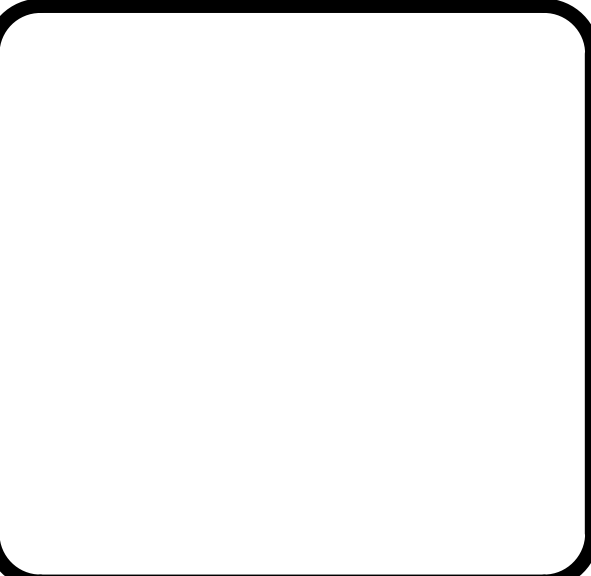

CLIENT MISSION CISD		
DATE 03/04/2022	PROJECT NUMBER P2132500AR	
DRAWING HISTORY		
No.	Description	Date
ISSUED FOR CONSTRUCTION		
BUILDING NUMBER		

PLUMBING PLAN

GENERAL NOTES - PLUMBING PLAN

1. THE CONTRACTOR SHALL COMPLY WITH ALL AUTHORITIES HAVING JURISDICTION.
2. ALL FINAL CONNECTIONS TO FIXTURES AND EQUIPMENT SHALL BE MADE BY THE PLUMBING CONTRACTOR.
3. ALL PLUMBING PIPING SHALL BE COORDINATED WITH ALL OTHER TRADES PRIOR TO ANY INSTALLATION OF ALL PLUMBING FIXTURES AND EQUIPMENT BY THE PLUMBING CONTRACTOR.
4. ALL FLOOR DRAINS AND FLOOR SINKS SHOWN ON THIS DRAWING SHALL BE COORDINATED WITH ALL OTHER TRADES PRIOR TO INSTALLATION.
5. REFER TO ARCHITECTURAL DRAWING FOR EXACT LOCATIONS OF FIXTURES, EQUIPMENT, ETC. DO NOT SCALE FROM PLUMBING DRAWINGS.
6. ALL WALL CLEAN-OUTS SHALL BE ACCESSIBLE BY AN ACCESS PANEL.
7. PROVIDE A DOUBLE EXTERIOR CLEAN-OUT (DFCO) ON ALL SANITARY LINES EXITING THE BUILDING.
8. ALL FLOOR DRAINS AND FLOOR SINKS SHALL BE PROVIDED WITH A TRAP PRIMER.
9. FIXTURES DESIGNATED AS ADA ACCESSIBLE BY ARCHITECT SHALL BE INSTALLED AT ADA ACCESSIBLE HEIGHT PER ARCHITECTURAL DETAILS.
10. ALL DOMESTIC COLD AND HOT WATER TAKE-OFFS SHALL HAVE AN ISOLATION SHUT-OFF VALVE.
11. FLOOR DRAINS AND FLOOR SINKS IN MECHANICAL ROOMS SHALL BE SET NOT LESS THAN 6" FROM HOUSEKEEPING PADS, RE: MECHANICAL DRAWINGS. DO NOT PLACE ON, OR IN, HOUSEKEEPING PAD, OR UNDERNEATH EQUIPMENT.
12. CONTRACTOR SHALL DEWATER ANY AREA AT OR BELOW GRADE PRIOR TO SETTING EQUIPMENT.
13. CONTRACTOR SHALL PLACE A TRAP PRIMER, TP-1, AND A HOSE BIBB, HB-2, IN ALL MECHANICAL ROOMS.
14. PROVIDE A HOSE-BIBB WITH WHEEL HANDLE IN ALL MECHANICAL ROOMS, HB-2.
15. ANY AND ALL WATER PIPING EXPOSED TO OUTSIDE ELEMENTS SHALL BE INSULATED AND HEAT TRACED TO PREVENT FREEZING.
16. ALL SANITARY 3" OR ABOVE SHALL BE INSPECTED BY A CAMERA PRIOR TO SUBSTANTIAL COMPLETION.

KEYED NOTES - PLUMBING PLAN

- P4 PROVIDE LINE SIZE CUT OFF VALVE FOR DRAIN DOWN FOR FREEZE PROTECTION.
- P5 ROUTE 1" COLD WATER PIPING ALONG EXISTING BLOCK WALL.
- P6 1/2" COLD WATER DOWN TO NIPPLE DRINKER. MOUNT NIPPLE DRINKER AT 30" AFG. MOUNTING HEIGHTS TO BE VERIFIED WITH AG INSTRUCTOR. PROVIDE COBURN SINGLE NIPPLE DRINKER BRACKET OR APPROVED EQUAL.
- P7 PROVIDE LINE SIZE CUT OFF VALVE.
- P9 COLD WATER DOWN TO BELOW GRADE. SIZE AS NOTED.
- P11 REFER TO ENLARGED PLUMBING PLAN.

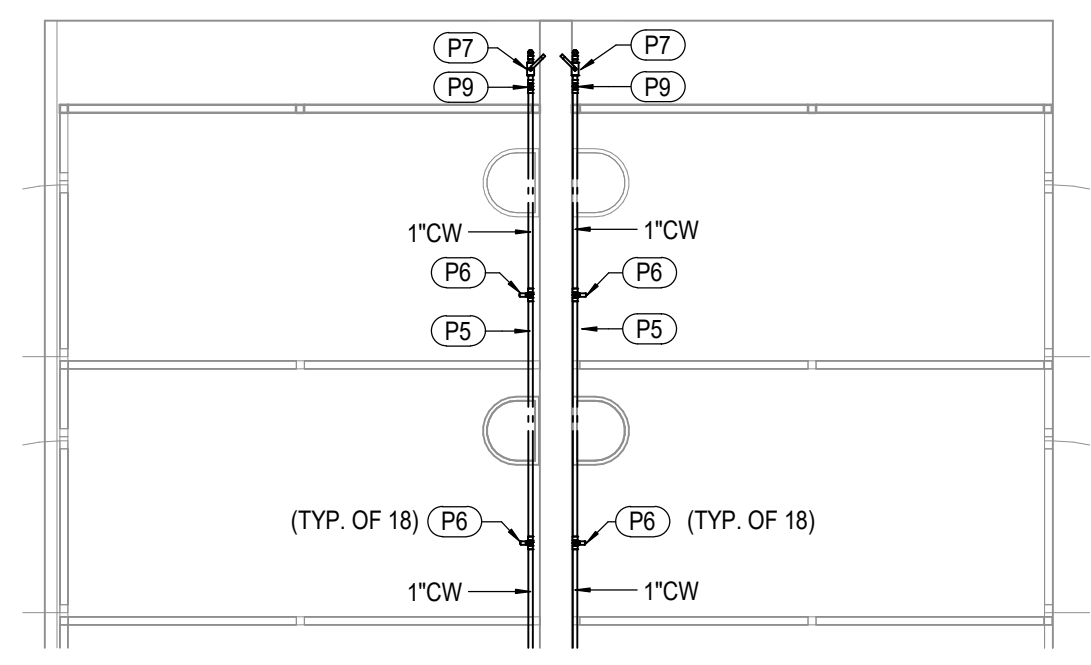

2 ENLARGED PLUMBING PEN PLAN - LEFT
 SCALE: 1/4" = 1'-0"

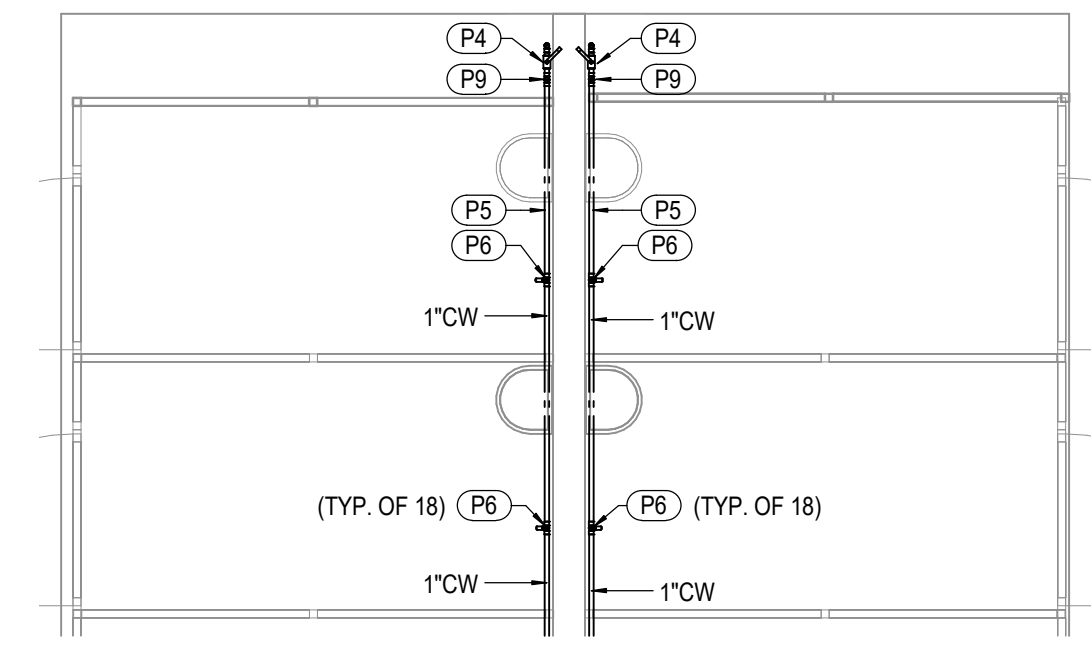

3 ENLARGED PLUMBING PEN PLAN - RIGHT
 SCALE: 1/4" = 1'-0"

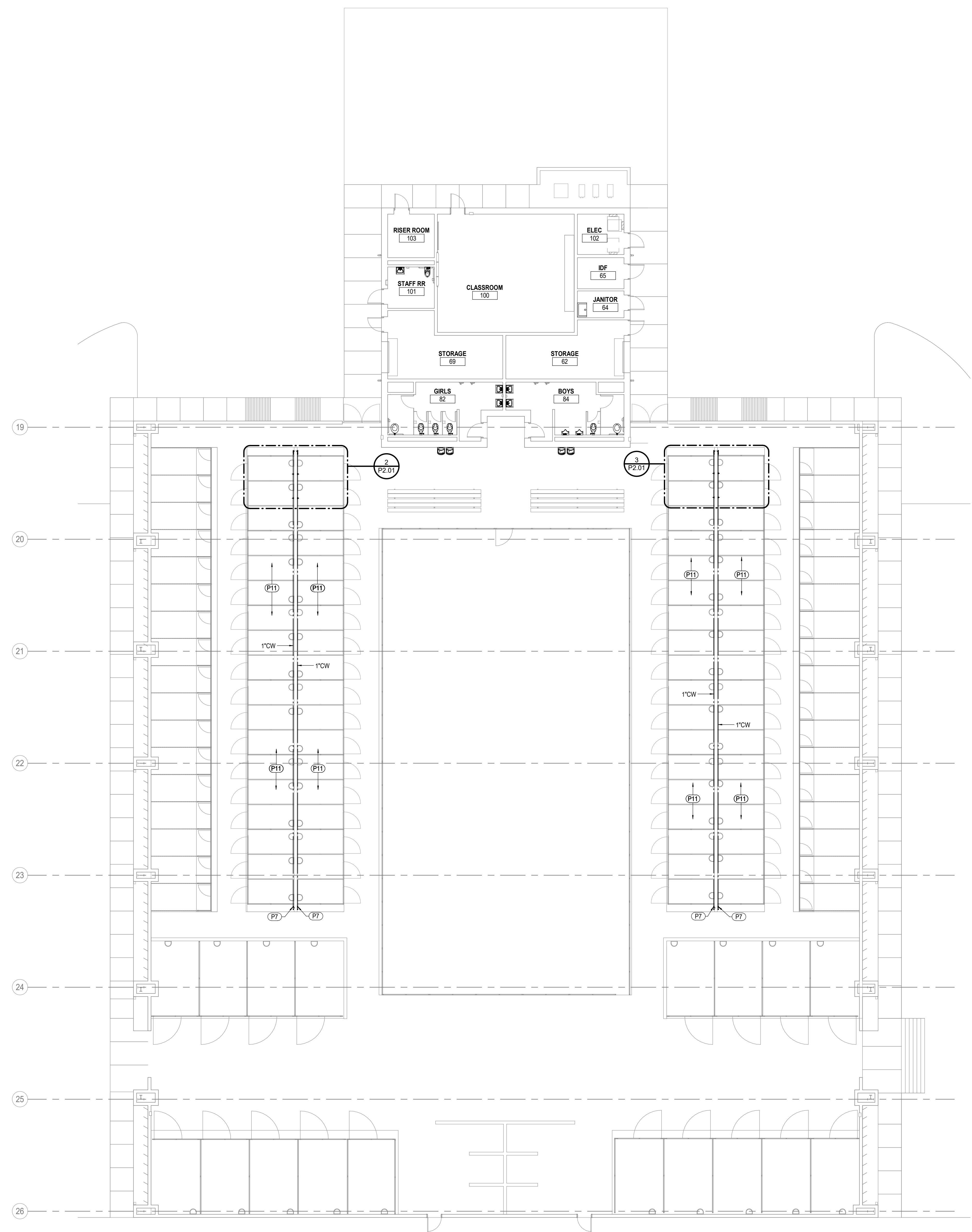

1 PLUMBING PLAN
 SCALE: 3/32" = 1'-0"



601 N.W. LOOP 410, SUITE 400
 SAN ANTONIO, TX 78216
 210-638-7200
 TX Firm: F-18672

PLUMBING PLAN
 P2.01
 FOR BLUEBEAM LABELING OOR:
 File Path: C:\Users\mreino\Documents\SP2132500AR - MEPT CENTRAL - RC21_mathew.trevino.rvt
 CHECKED BY: DON RICHARDS
 DRAWN BY: MATTHEW TREVINO
 Plot Stamp: 3/4/2022 9:28:25 AM

SUBJECT: Approval of the Election Services Contract for the May 7, 2022 Mission CISD Board of Trustees Election with the Hidalgo County Elections Administrator

PRESENTER: Joel Garcia, Assistant Superintendent for Finance

BACKGROUND INFORMATION

The Texas Secretary of State specifies Saturday, May 7, 2022, as the Uniform Election Date for the MCISD Board of Trustee Election. Section 31.092(a) of the Texas Election Code permits the Hidalgo County Elections Administrator to contract with Mission Consolidated Independent School District to perform election services for the May 7, 2022 Board of Trustees Election.

On February 18, 2022 we received correspondence from the Hidalgo County Elections Division indicating that they would administer a full election services contract for the Mission CISD Board of Trustee Election and is in the process of providing a cost estimate and a full-service contract to the District for Election Services. On March 31, 2022 the Elections Division submitted the contract and cost estimate for the full-service contract. The cost estimate came in at \$64,800.04. The estimate is based on a 100% voter turnout. After the election an invoice will be submitted to the District reflecting actual costs. Mission CISD paid \$49,715.46 for Election Services for the November 3, 2020 Board of Trustee Election.

FUNDING SOURCE

General Fund – \$64,800.04

CONSIDERATION

Approval of the Election Services Contract for the May 7, 2022 Mission CISD Board of Trustees Election with the Hidalgo County Elections Administrator

CONTACT PERSON (S)

Joel Garcia, Assistant Superintendent for Finance
Sylvia Cruz, Director for Payroll, Employee Benefits and Risk Management

WHEREAS, pursuant to Section 43.007(e), each countywide polling place must allow a voter to vote in the same elections in which the voter would be entitled to vote in the county election precinct in which the voter resides; and

WHEREAS, ADMINISTRATOR has provided costs for election services to be rendered by ADMINISTRATOR'S office pursuant to the terms of this Contract, which costs are set out in Article VI hereof; and

NOW, THEREFORE, the COUNTY, through the ADMINISTRATOR, and the ENTITY for good and valuable consideration, the adequacy and receipt of which is hereby acknowledged, do hereby agree to hold contract, covenant and agree as follows:

ARTICLE I PURPOSE

1.01. The parties hereto have entered into this Contract for election services described in Article II to be provided to the ENTITY for its election to be held on **MAY 7, 2022**, and any runoff, if applicable.

1.02 If applicable, acknowledgement of Shared Polling Places. The ENTITY acknowledges that the ADMINISTRATOR, as the County's Contracting Officer in accordance with Section 31.092 of the Texas Election Code, may enter into similar Election Services Contracts with any other entity in the same county that may be running their election concurrently. In such event, the ENTITY agrees to share common polling places with the other entities. It is not the intent of this paragraph to establish a joint election, but rather to share services, equipment, and the costs when it is appropriate, efficient, and economical to do so.

ARTICLE II SERVICES

2.01. The COUNTY, through the ADMINISTRATOR, agrees to provide to the ENTITY the following:

- (A) Procure, provide, code and distribute Hart Hybrid voting systems, election equipment and transport equipment to and from the polling locations, including Early Voting and Election Day polling locations, for the ENTITY;
- (B) Prepare and provide Hart Hybrid training for election workers;
- (C) Prepare and provide Logic and Accuracy testing on ENTITY's election ballot for every Hart Hybrid voting machines to be utilized by ENTITY during Early Voting and Election Day;
- (D) Procure, provide, prepare and code Electronic Poll Book(s) per polling locations with the Voter Registration Database. To include laptop(s), training for poll book, insurance, and delivery fee, as well as supplies such as, but not limited to labels and printer;

- (E) Provide and prepare all mail-in ballot supplies, including applications, paper ballots, envelopes and postage;
- (F) Provide training for Judges/Clerks;
- (G) Procure, provide, prepare, and distribute all necessary election supplies, including:
 1. Ballots (print and distribution only);
 2. Election kits and election paperwork;
 3. Ballot boxes and voting booths;
- (H) Provide cages and covers, cage kit, to include, but not limited to surge protectors, tape, printer, headphones and scanner as well as supplies such as bags, aprons, clipboards, pens, pencils, rulers, magnifiers, inkpads, screen cloths, sanitizers and badges;
- (I) Procure Early Voting polling places and Election Day polling places;
- (J) Prepare Writ of Election to election officers and notice of appointment to Presiding and Alternate judges, as required by law;
- (K) Prepare, distribute, and publicize joint notice of election (Texas Election Code Section 4.003(a)(1) and Early Voting and Election Day schedules in newspaper;
- (L) Notify the election judges of the date, time and place of the election;
- (M) Procure and pay election judges and clerks for Early Voting and Election Day voting;
- (N) Provide general supervision during the contracted Election period. Advisory services in connection with the decisions to be made and the actions to be taken by the ENTITY may be provided on an as needed basis;
- (O) Procure and pay Ballot Board members;
- (P) Provide information for election officers;
- (Q) Provide such incidental related services as may be necessary to conduct the election;
- (R) Serve as the Early Voting Clerk;
- (S) Establish a Central Counting Station for the purpose of tabulating ballots; and
- (T) Tabulate election results in preparation for ENTITY's canvassing.
- (U) Preserve locked ballot boxes containing voted ballots securely in a locked room for 60 days as required by Texas Election Code Section 66.058, at which time, the records will be retained by the Hidalgo County Elections Administrator to serve as custodian for the remainder of the twenty-two month preservation period.
- (V) The ADMINISTRATOR shall be the agent of the ENTITY for the purposes of contracting with third parties with respect to the election expenses within the scope of the County Elections Administrator's duties;

- (W) The COUNTY shall file copies of this Contract with the County Treasurer and the County Auditor;
- (X) In accordance with Section 31.100(b) of the Texas Election Code, only actual expenses directly attributable to this Contract may be paid. The ADMINISTRATOR shall submit the actual costs for items contracted pursuant to the Contract with the ENTITY as soon as all invoices from third party vendors are received;
- (Y) If applicable, the COUNTY agrees to provide the election services described herein for a Runoff election.
 - i. The County may combine polling locations in accordance with section 42.0051 of the Election Code, in order to properly supervise and conduct a Runoff election.
 - ii. If a Runoff election is required, the ENTITY hereby agrees to the combining of polling locations, in accordance with section 42.0051 of the Election Code.
 - iii. The COUNTY, through the ADMINISTRATOR, agrees to provide to the ENTITY the costs for any Runoff Election services to be rendered by the ADMINISTRATOR'S office pursuant to the terms of this Contract as soon as practicable, once a Runoff is determined necessary.
 - iv. In accordance with Section 31.100(b) of the Texas Election Code, only actual expenses directly attributable to this Contract may be paid. The ADMINISTRATOR shall submit the actual costs for items contracted pursuant to the Contract with the ENTITY as soon as all invoices from third party vendors are received regarding the Runoff.
- (Z) Provide signage to be placed at each polling location that shows Texas Penal Code Section 46.03(a)(2) as it relates to prohibiting firearms on the premises of a polling place;

2.02 The ENTITY shall be responsible for performing the following:

- (A) Payment of all necessary election supplies as required by the COUNTY, including but not limited to ballots, election kits, mail-in ballot supplies, laptop rental, labels and combination forms;
- (B) Pay the proportionate cost of judges and election workers for hourly pay submitted by the County Elections Administrator at the rate of \$14.00 per hour for Election Judges and \$12.00 per hour for Alternate Judges and Early Voting Clerks for both Early Voting and Election Day and pay the proportionate cost for training of Judges and Clerks at the rate of \$10.00 per hour per person.
- (C) Reimburse the COUNTY for the cost for liability insurance coverage for election workers employed for both Early Voting and Election Day;
- (D) Canvass the Election Results for the ENTITY'S governing body;

- (E) As stated in Section 31.096 of the Texas Election Code, this Contract may not change:
 - (1) the authority with whom applications of candidates for a place on a ballot are filed; and
 - (2) the authority with whom documents are filed under Title 15. Under this Contract, the Hidalgo County Elections Administrator shall be the custodian of voted ballots for 60 days after the date of the election, as required by Texas Election Code 66.058, at which time, the records will be retained by the Hidalgo County Elections Administrator to serve as custodian for the remainder of the twenty two month preservation period.
- (F) Reimburse the COUNTY for any and all costs associated with recounts and/or election contests associated with the election;
- (G) Confirm and/or correct the boundaries of the political subdivision holding the election on a map provided by the County. Once confirmed and/or corrected, Entity certifies the veracity of the boundaries and geographical area that represents the Entity and the area subject to the election.
- (H) If applicable, in consideration for the services provided for a Runoff Election by the COUNTY, the ENTITY agrees to pay ADMINISTRATOR for the costs of services for a Runoff election.
- (I) Create the appropriate ballot style and candidate placement for the Entity's election. Once confirmed and/or corrected Entity shall verify the appropriateness of their ballot under the law.

ARTICLE III
SCHEDULE FOR PERFORMANCE OF SERVICES

- 3.01. Specific services to be provided related to the general services identified in Article II shall be performed in accordance with the time requirements set out in the Texas Election Code.

ARTICLE IV
SERVICES NOT PROVIDED BY COUNTY

- 4.01. ADMINISTRATOR shall have no responsibility for ensuring the passage of the appropriate Election Order by the ENTITY, publishing and (or) posting the Election Order as required by the Texas Election Code section 3.004(3), or Texas Election Code 67.002(2) which is canvassing election results. In addition, ADMINISTRATOR shall have no responsibility for creating the appropriate ballot and candidate placement for the Entity's election.

ARTICLE V
TERM

- 5.01. Except as hereinafter set out, the term of this Contract shall be from the time of execution until all items with respect to this Contract and the election held hereunder have been completed.

ARTICLE VI
COST OF SERVICE AND BILLING

In consideration for the services provided hereunder by ADMINISTRATOR, the ENTITY agrees to pay ADMINISTRATOR for the following costs of services:

6.01 HART Hybrid:

- (A) One base charge of \$475.00 for Coding Hybrid voting machines, a \$25.00 additional charge per additional ballot styles and a minimum of a \$10.00 charge for requested changes on Coded Ballot;
- (B) A \$10.00 recording fee for each Audio File;
- (C) Cost of creating election media, such as but limited to V-drives, Verity Keys; etc. at \$100.00 per location.
- (D) The amount of \$610.00 leasing fee for each Verity Scan/ Ballot Box, a \$150.00 leasing fee for each Verity Duo Go (curbside) Voting Machine, a \$465.00 leasing fee for each Verity Controller, and a \$447.00 leasing fee for each Verity Touch Duo Voting Machine;
- (E) Cost of delivery and pick-up of Verity Duo Voting Equipment for Each Voting and Election Day to include fuel charge and mileage at COUNTY's cost;
- (F) The above described fees shall be additionally charged for any Runoff Election.

6.02 Electronic Poll Book:

- (A) Database access at \$100.00 per day;
- (B) To include but not limited to the Early Voting and Election Day laptop rentals at \$150.00 per location;
- (C) Printer label fee of \$.03 per label (price subject to change);
- (D) Creation of separate Username and password for each polling location at \$20.00 per location;

6.03 Fee for Early Voting and Election Day Combination forms, maps, election kits, Verity Access Thermal code paper and 'I VOTED' stickers. One-hundred sample ballots at no charge with additional sample ballots at twenty cents per copy; No charge for provisional bags, table tops if necessary, ballot box(es), custom signs and flags;

6.04 Reimbursement of ballot supplies, including applications, paper ballots, correspondence, envelopes and postage at COUNTY's cost;

6.05 Reimbursement fee for publications of all notices and newspaper advertisements, (if applicable)

6.06 Reimbursement rental fees incurred for early voting polling places and Election Day polling places, as ordered and if applicable;

6.07 (A) Cost of judges and election workers for time worked to be submitted to the ENTITY by the ADMINISTRATOR. The ENTITY shall reimburse the COUNTY for a the cost of payroll for election workers at \$14.00 per hour for Election Judge, \$12.00 per hour for Alternate Judge and Clerk(s); includes cost of payroll for training of Election Judge, Alternate Judge and Clerk(s) at \$10.00 per hour per person;

- (B) Reimburse the County for the cost of payroll overtime incurred by County for regular full time County employees who work during the contracted election (cost to be shared with each contracted entity);
- 6.08 Pay for the cost of the Ballot Board judge at \$14.00 per hour and Ballot Board clerks at \$12.00 per hour;
- 6.09 One copy of canvass report provided to ENTITY at no charge; each additional canvass report requested to be reimbursed by the ENTITY at COUNTY's cost;
- 6.10 Reimbursement to the COUNTY for the cost of liability insurance coverage as set by the County for all election workers employed for the elections;
- 6.11 Reimbursement to the COUNTY for the cost of the use of wireless cell phones at polling locations with the rate set by the wireless vendor at the time of usage which includes an additional per minute fee as charged by the vendor, a service charge of \$10.00 per phone line and a vendor base fee of \$4.99 per phone line;
- 6.12 Billing:
- (A) The form of the invoice to be used in the final billing by the COUNTY, includes a good faith estimate of costs and is attached hereto as Exhibit A.
- (B) After the election and as soon as practicable, upon receiving final invoice from third party vendors, the ADMINISTRATOR shall prepare and will send to the ENTITY, a final itemized invoice with the actual costs of the Election and will include the 10% Administrative Fee of the actual costs as set forth by Texas Election Code Sec. 31.100 (d).
- (C) Full payment of the remaining balance, if any, shall be made by the ENTITY within thirty (30) days of receipt of the invoice.
- (D) Payment shall be made by check payable to the Hidalgo County Elections Department.
- (E) Notice. Except as may be otherwise specifically provided in this contract, all notices, demands, requests or communication required or permitted hereunder shall be in writing and shall either be (i) personally delivered against a written receipt, or (ii) sent by registered or certified mail, return receipt requested, postage prepaid and addressed to the parties at the addresses set forth below, or at such other addresses as may have been theretofore specified by written notice delivered in accordance herewith:

Yvonne Ramón
 Elections Administrator
 Hidalgo County Elections Department
 PO Box 659
 Edinburg, Texas 78540

Sylvia Cruz
 Director for Payroll, Employee Benefits, and Risk Management
 1201 Bryce Drive
 Mission, Texas 78572

(F) Any balances, if any remain after the payment of all costs of election bills, shall be the property of the ENTITY and returned to it.

ARTICLE VII

- 7.01 IF ANY OF THE ELECTION EQUIPMENT IS LOST, STOLEN, DESTROYED, OR DAMAGED, THE CITY, SCHOOL DISTRICT OR ENTITY WHO LEASED THE EQUIPMENT IS LIABLE FOR THE DAMAGE AND AGREES TO PAY THE ADMINISTRATOR THE COST OF THE REPLACEMENT OR REPAIR OF THE ELECTION EQUIPMENT SO LOST, STOLEN, DESTROYED OR DAMAGED.

ARTICLE VIII

GENERAL PROVISIONS

- 8.01. This Contract shall be construed under and in accordance with the laws of the State of Texas, and all obligations of the parties created hereunder are performable in Hidalgo County, Texas.
- 8.02. In case any one or more of the provisions contained in this Contract shall for any reason be held to be invalid, illegal or unenforceable in any respect, such invalidity, illegality or unenforceability shall not affect any other provision thereof, and this Contract shall be construed as if such invalid, illegal or unenforceable provision had never been contained herein.
- 8.03. This Contract constitutes the sole and only agreement of the parties hereto and supersedes any prior understanding or written or oral agreement between the parties respecting the written subject matter.
- 8.04. No amendment, modification, or alteration of the term hereof shall be binding unless the same be in writing, dated subsequent to the date hereof and duly executed by the parties hereto

SIGNED this 13th day of March, 2022

APPROVAL COUNTY OF HIDALGO:

Mission Consolidated Independent School District

ENTITY

BY: _____

RICHARD F. CORTEZ
COUNTY JUDGE

BY: _____

Gerardo Zamora, President
Board of Trustees

ATTEST:

BY: _____

ARTURO GUAJARDO, JR.
COUNTY CLERK

BY: _____

PRINT: Roy Vela, Secretary

TITLE: Board of Trustees

ELECTIONS ADMINISTRATOR

BY: _____

YVONNE RAMÓN

APPROVED AS TO LEGAL FORM:

OFFICE OF CRIMINAL DISTRICT ATTORNEY
RICARDO RODRIGUEZ, JR.

BY: _____

JOSEPHINE RAMIREZ SOLIS,
Assistant District Attorney



2022 Hidalgo County Elections Contract Estimate

EXHIBIT A

PLEASE NOTE THAT THIS TOOL IS FOR ESTIMATION PURPOSES ONLY.
PRICES ARE SUBJECT TO CHANGE AS DETERMINED BY FINAL INVOICE.

ELECTION: Mission CISD School Trustee Place 1, 6 & 7		DATE: May 7, 2022			
6.01 Coding Services for HART		Price	Quantity	Total	
A	Base Charge: Ballot Coding	\$475.00	1	\$475.00	
B	Ballot Audio Files	\$10.00	9	\$90.00	
C	Election Media per Polling Location(s)	\$100.00	8	\$800.00	
D	Verity Controller(s)	\$465.00	7	\$3,255.00	
D	Covid Curbside Verity Controller(s)	\$0.00	0	\$0.00	
D	Verity Touch Duo Machine(s)	\$447.00	17	\$7,599.00	
D	Covid Curbside Verity Touch Duo Machine(s) (7)	\$3,129.00	0	\$0.00	
D	Verity Scan and Ballot Box	\$610.00	7	\$4,270.00	
D	Verity Duo Go Carrier (Curbside Voters)	\$150.00	14	\$2,100.00	
E	Delivery/ Pick-up Fee (includes Mileage)	\$960.00	1	\$960.00	
Total iVotronic Coding Charges				\$19,549.00	
6.02 Electronic Poll Book (VoteSafe)		Price	Quantity	Total	
A	Voter Registration Database Access (Per Day)	\$100.00	9	\$900.00	
B	EV/ ED Laptop Rental (includes Bar Code Scanner/ Brother Printer)	\$150.00	7	\$1,050.00	
B	Covid Curbside EV/ED Laptop Rental (includes Bar Code Scanner/ Brother Printer)(7)	\$1,050.00	0	\$0.00	
C	Printer Labels (31,141 per vote)	\$0.03	62282	\$1,868.46	
D	Username/Password - Per Polling Location	\$20.00	7	\$140.00	
Total Electronic Poll Book Charges				\$3,958.46	
6.03 Supplies		Price	Quantity	Total	
	Early Voting Combination Forms	\$0.55	650	\$357.50	
	Election Day Combination Forms	\$0.55	650	\$357.50	
	Election Judge Kit for Early Voting	\$50.00	2	\$100.00	
	Election Judge Kit for Election Day	\$50.00	6	\$300.00	
	Verity Access Thermal Code paper (per vote)	\$0.10	31141	\$3,114.10	
	EV/ ED Thermal Ballot paper (per vote)	\$0.40	31141	\$12,456.40	
	I VOTED stickers (per vote)	\$0.01	31141	\$311.41	
	Polling Location Map(s)	\$17.00	8	\$136.00	
	100 Sample ballots provided. Additional Copies of Sample Ballots @ \$0.20 each.	\$0.20	500	\$100.00	
	Covid PPE's per location	\$0.00	1	\$0.00	
Total Supplies Charges				\$17,232.91	
6.04 Mail & Ballot Service		Price	Quantity	Total	
	Mail-in-Paper Ballots	\$0.40	500	\$200.00	
	Mail-in-Ballots Kit(s) per request	\$2.00	500	\$1,000.00	
	Postage Mail-in-Ballots (per request)	\$0.73	500	\$365.00	
	Correspondence Postage	\$0.58	6	\$3.48	
Total Mail & Ballot Service Charges				\$1,568.48	
6.05 Advertisements/Notices		Price	Quantity	Total	
	The Monitor newspaper	\$1,800.00	1	\$1,800.00	
	Local newspaper		0	\$0.00	
Total Advertisement/Notice Charges				\$1,800.00	
6.07 *Payroll for Training and Election Poll Workers		Price	Total		
	Payroll for Early Voting Employees	\$13,802.00	\$6,901.00		
	Payroll for Election Day Employees	\$6,066.00	\$3,033.00		
Total Payroll Charges				\$9,934.00	
Payroll for Staff Overtime		Price	Total		
	Payroll for Early Voting and Election Day Staff Employees	\$3,960.40	\$3,960.40		
Total Payroll Charges				\$3,960.40	
6.08 Payroll for Ballot Board		Price	Quantity	Total	
	Ballot Board	\$550.00	1	\$550.00	
Total Ballot Board Charges				\$550.00	
6.10 Insurance		Hourly rate	Hours wk	%	Total
	Liability insurance for Early Voting Supervisors (2) (hourly rate X hrs worked X .0021)	\$ 14.00	221	0.0021	\$6.50
	Liability insurance for Early Voting Alternate/Clerks (8) (hourly rate X hrs worked X .0021)	\$ 12.00	884	0.0021	\$22.28
	Liability insurance for Election Day Presiding Judges (6) (hourly rate X hrs worked X .0021)	\$ 14.00	93	0.0021	\$2.73
	Liability insurance for Election Day Alternate/Clerks (24) (hourly rate X hrs worked X .0021)	\$ 12.00	372	0.0021	\$9.37
Total Insurance Charges				\$40.88	
6.11 Cell Phones		Price	Quantity	Total	
	Verizon Wireless phone (subject to change with out notice)	\$45.00	7	\$315.00	
Total Cell Phone Charges				\$315.00	
136		Subtotal		\$58,909.13	
*Shared Cost with County		Administrative Fees (10%)		\$5,890.91	
		ESTIMATED GRAND TOTAL		\$64,800.04	

SUBJECT: Approval to Amend Order of General Election for May 7, 2022,
Mission CISD Board of Trustees Election

PRESENTER: Joel Garcia, Assistant Superintendent for Finance

BACKGROUND INFORMATION

Section 3.004 of the Texas Election Code requires the Board of Trustees of an independent school district to order all regular elections for trustees and give notice thereof as specified in Section 4.003 of the Texas Election Code and Section 41.001 of the Texas Election Code requires that election for trustees in independent school districts shall be held a uniform election date as provided by law.

Saturday, May 7, 2022 is a uniform election date as provided by law and the Board of Trustees of Mission CISD has previously adopted the May uniform election date as the date of the election for trustees for Mission CISD.

ADMINISTRATIVE CONSIDERATIONS

Presented for consideration is the Mission CISD Order of General Election ordering a Trustee election. The Ordinance defines the parameters for the elections and includes the polling times and places during the early voting and election day.

The Ordinance calls for Trustee elections for positions 1, 6 and 7 to serve for terms of four years each position.

In order to ensure that the May 7, 2022 Board of Trustees Election is in compliance with the Texas Election Code the Order of General Election must be approved on or before Friday, February 18, 2022.

FUNDING SOURCE AND AMOUNT

Not Applicable

RECOMMENDATION

Approval to Amend Order of General Election for May 7, 2022, Mission CISD Board of Trustees Election.

CONTACT PERSON (S)

Joel Garcia, Assistant Superintendent for Finance
Sylvia Cruz, Director for Payroll, Employee Benefits and Risk Management

**ORDER OF GENERAL ELECTION FOR OTHER POLITICAL SUBDIVISIONS
 ORDEN DE ELECCIÓN GENERAL PARA OTRAS SUBDIVISIONES POLÍTICAS**

An election is hereby ordered to be held on ____/____/____ for the purpose of voting on:
 (date)

(Por la presente se ordena celebrar una elección el ____/____/____ con el propósito de votar sobre.)
 (fecha)

List Offices/Propositions/Measures on the ballot (Enúmere los puestos/proposiciones/medidas oficiales en la boleta)

Early voting by personal appearance will be conducted each weekday at:
 (La votación adelantada en persona se llevará a cabo de lunes a viernes en:)

The Main Early Voting Location (sitio principal de votación adelantada)

Location (sitio) Hours (horas)

--	--

Branch Early Voting Locations (sucursal sitios de votación adelantada)

Location (sitio) Hours (horas)

Early voting by personal appearance will be conducted each weekend at:
 (La votación adelantada en persona se llevará a cabo en el fin de semana en:)

The Main Early Voting Location (sitio principal de votación adelantada)

Location (sitio) Hours (horas)

--	--

Branch Early Voting Locations (sucursal sitios de votación adelantada)

Location (sitio) Hours (horas)

Applications for ballot by mail shall be mailed to:
 (Las solicitudes para boletas que se votarán adelantada por correo deberán enviarse a:)

Name of Early Voting Clerk
(Nombre del Secretario/a de la Votación Adelantada)

Address (Dirección)

City (Ciudad) Zip Code (Código Postal)

Telephone Number (Número de teléfono)

Email Address (Dirección de Correo Electrónico)

Early Voting Clerk's Website (Sitio web del Secretario/a de Votación Adelantada)

Applications for Ballots by Mail (ABBM)s must be received no later than the close of business on:
(Las solicitudes para boletas que se votarán adelantada por correo deberán recibirse no más tardar de las horas de negocio el:)

_____/_____/_____.
(date)(fecha)

Federal Post Card Applications (FPCAs) must be received no later than the close of business on:
(La Tarjeta Federal Postal de Solicitud deberán recibirse no más tardar de las horas de negocio el:)

_____/_____/_____.
(date)(fecha)

Issued this _____ day of _____, 20 _____.
(day) (month) (year)

(Emitida este día _____ de _____, 20 _____.)
(día) (mes) (año)

Signature of Presiding Officer (Firma del Dirigente que Preside)

Gerardo Zamora

Mr. Roy Vela

Mr. Juan Gonzalez

Signature of Board Member
(Firma del Director)

Signature of Board Member
(Firma del Director)

Mrs. Veronica R. Mendoza

Signature of Board Member
(Firma del Director)

Mrs. Petra Ramirez

Signature of Board Member
(Firma del Director)

Mrs. Minnie Rodgers

Signature of Board Member
(Firma del Director)

Mrs. Iris Iglesias

Signature of Board Member
(Firma del Director)

Instruction Note: A copy of this election order must be delivered to the County Clerk/Elections Administrator and Voter Registrar not later than 60 days before election day.

Nota de Instrucción: Se deberá entregar una copia de esta orden de elección al/a la Secretario(a) del Condado/Administrador(a) de Elecciones y el/la Registrador(a) de Votantes a más tardar 60 días antes del día de elección.

MAY 7, 2022 SPECIAL CONSTITUTIONAL AMENDMENT
ELECTION AND LOCAL ENTITIES ELECTIONS
EARLY VOTING POLLING LOCATIONS, DATES AND HOURS

(7 DE MAYO DEL 2022 ELECCIÓN DE ENMIENDA CONSTITUCIONAL ESPECIAL Y ELECCIONES DE ENTIDADES LOCALES LUGARES DE VOTACIÓN ANTICIPADA FECHAS Y HORARIOS)

During Early Voting, eligible voters can cast their ballot at any polling location.
(Durante la votación anticipada, los votantes elegibles pueden emitir su voto en cualquier casilla de votación.)

Days (Días)	Dates (Fechas)	Hours (Horario)
Monday/lunes- Saturday/sábado	April 25, 2022 – April 30, 2022	8:00 AM – 6:00 PM
Sunday/domingo	May 1, 2022	Closed/Cerrado
Monday/lunes – Tuesday/martes	May 2, 2022 – May 3, 2022	7:00 AM – 7:00 PM

<p>1. ALAMO Large Meeting Room (Sala de reuniones grande) Sgt. Fernando de la Rosa Library 416 N. Tower Rd. Alamo, TX</p>	<p>2. ALTON Gymnasium (Gimnasio) Alton Recreation Center 349 Dawes Ave. Alton, TX</p>	<p>3. DONNA Main Area (Área Principal) Amigos Del Valle 1408 Silver Ave. Donna, TX</p>	<p>4. EDCOUCH Meeting Room (Sala de Reuniones) Sgt. Rodriguez Community Center 320 W. Santa Rosa Ave. Edcouch, TX</p>	<p>5. EDINBURG STAC Lounge (Salón STAC) UTRGV 1201 W. University Dr. Edinburg, TX</p>
<p>6. EDINBURG MAIN EARLY VOTING LOCATION Annex Room (Habitación Anexa) Elections Annex Building 317 N. Closner Blvd. Edinburg, TX</p>	<p>7. EDINBURG Conference Room (Sala de Conferencia) San Carlos Endowment Center 107 Sunflower Rd. Edinburg, TX</p>	<p>8. ELSA Court Chambers (Salas de la Corte) Elsa Municipal Court 216 E. 4th St. Elsa, TX</p>	<p>9. GRANJENO Conference Room (Sala de Conferencia) Granjeno City Hall 6603 S. FM 494 Granjeno, TX</p>	<p>10. HIDALGO Commissioners Chambers (Sala de Comisionados) Hidalgo City Hall 704 Ramon Ayala Dr. Hidalgo, TX</p>
<p>11. LA JOYA Gymnasium (Gimnasio) La Joya Youth Center 604 Salomon Chapa Dr. La Joya, TX</p>	<p>12. LA VILLA Classroom (Sala de Clase) Multi-Purpose Building 500 E. 9th St. La Villa, TX</p>	<p>13. MCALLEN Main Entrance (Entrada Principal) Fireman's Pumphouse 201 N. 1st St. McAllen, TX</p>	<p>14. MCALLEN Exercise Room (Sala de Ejercicio) Lark Community Center 2601 Lark Ave. McAllen, TX</p>	<p>15. MCALLEN Exercise Room (Sala de Ejercicio) Palm View Community Center 3401 Jordan Ave. McAllen, TX</p>
<p>16. MCALLEN Community Room (Sala de Comunidad) South Texas College Nursing Campus Building B 1901 S. McColl Rd. McAllen, TX</p>	<p>17. MCALLEN Old Cafeteria Room 126 (Antiguo Salón 126 de la Cafetería) South Texas College Pecan Campus Building H 3201 Pecan Blvd. McAllen, TX</p>	<p>18. MERCEDES Main Entrance (Entrada Principal) Mercedes Civic Center 520 E. 2nd St. Mercedes, TX</p>	<p>19. MISSION Gymnasium (Gimnasio) Bannworth Gym 1822 N. Shary Rd. Mission, TX</p>	<p>20. MISSION Back Gymnasium (Gimnasio Atrás) Mission Parks and Recreation 721 Bryan Rd. Mission, TX</p>
<p>21. PALMHURST Library Resource Center (Centro de recursos de la Biblioteca) Rafael A. Cantu Jr. High School 5101 N. Stewart Rd. Palmhurst, TX</p>	<p>22. PALMVIEW Back Entrance (Entrada Trasera) Pct. 3 "The Mansion" 2401 N. Moorefield Rd. Palmview, TX</p>	<p>23. PALMVIEW Gymnasium (Gimnasio) Palmview Recreation Center 406 W. Veterans Blvd. Palmview, TX</p>	<p>24. PEÑITAS P-15 (P-15) Peñitas Fire Station Building 1320 S. Main St. Peñitas, TX</p>	<p>25. PHARR Conference Center (Centro de Conferencias) Development and Research Center 850 W. Dicker Rd. Pharr, TX</p>
<p>26. PHARR Small Hall (Salón Pequeño) Jose Pepe Salinas Center 1011 West Kelly Ave. Pharr, TX</p>	<p>27. PROGRESO LAKES Lobby (Vestíbulo) Progreso Lakes City Hall 631 Lakeway Dr. Progreso Lakes, TX</p>	<p>28. SAN JUAN Multi-Purpose Room (Salón Multiuso) San Juan Memorial Library 1010 S. Standard Ave. San Juan, TX</p>	<p>29. SULLIVAN CITY Lobby (Vestíbulo) Sullivan City WIC Clinic 371 W. Expy. 83 Sullivan City, TX</p>	<p>30. WESLACO Conference Room A & B (Sala de Conferencias A y B) Business Visitor and Event Center 275 S. Kansas Weslaco, TX</p>

For more election information, you can visit our website at www.hidalgocounty.us/elections, or call us at (956)318-2570. (Para obtener más información sobre las elecciones, puede visitar nuestro sitio web en www.hidalgocounty.us/elections, o llámenos a (956) 318-2570.)

SUBJECT: Approval of the Interlocal Participation Agreement (IPA) between TASB Risk Management Fund and Mission CISD

PRESENTER: Joel Garcia, Assistant Superintendent for Finance

BACKGROUND INFORMATION

The Interlocal Participation Agreement (IPA) is the foundational agreement of the TASB Risk Management Fund (Fund). The Fund is a self-funded risk pool, and the IPA is the agreement through which Mission CISD participates in the Fund. The IPA sets out the basic terms, conditions, and requirements of Fund membership.

Through an executed IPA, Mission CISD may participate in the various lines of coverage offered by the Fund. Membership in each specific Fund program is created and controlled through a Contribution and Coverage Summary (CCS).

The IPA is approved once by each Fund Member's board. It remains in effect until the Fund Member ceases to participate in at least one Fund coverage program or the Fund terminates the IPA. The Fund is an interlocal entity formed under the provisions of Chapter 791 of the Texas Government Code. This law requires that an interlocal agreement be authorized by the governing body of each party to the agreement.

ADMINISTRATIVE CONSIDERATIONS

The IPA was last approved by the Fund Board in April 2012 and signed by Mission CISD on August 15, 2012 as a universal IPA covering all Fund programs. It has not been modified since 2012. The Fund reviews and updates its IPA at least once every ten years or more frequently, as needed. Mission CISD currently utilizes the Texas Association of School Boards (TASB) to administer its Unemployment Compensation Program. The renewal date for this policy will be October 1, 2022. Administration recommends the approval of the IPA which will allow Mission CISD to continue its Unemployment Compensation Coverage without having to go out to bid every single year for the same coverage.

FUNDING SOURCE AND AMOUNT

Not Applicable.

RECOMMENDATION

Approval of the Interlocal Participation Agreement (IPA) between TASB Risk Management Fund and Mission CISD

CONTACT PERSON (S)

Joel Garcia, Assistant Superintendent for Finance

Sylvia Cruz, Director of Payroll, Employee Benefits and Risk Management



March 1, 2022

Dr. Carol Perez
Mission CISD
cgpere95@mcisd.org

Participation in TASB Risk Management Fund Coverage Programs

Dear Dr. Perez:

Please accept this letter as formal written notice that the Interlocal Participation Agreement (IPA) between Mission CISD and the TASB Risk Management Fund (Fund) is amended by the Fund effective May 1, 2022. The IPA is the foundational agreement by which eligible organizations join the Fund.

The amended IPA will replace your current IPA with the Fund. A copy of the new IPA is included for review and execution. It was last amended in 2012. Pursuant to Chapter 791 of the Texas Government Code, the new IPA must be authorized and approved by your Board of Trustees.

Along with the new IPA, a Frequently Asked Questions document with more information and a summary of changes is included to assist you in executing the agreement. The updates to the IPA focus on three areas: 1) clarity of purpose and meaning, 2) updates to Fund Member duties and obligations, and 3) revisions to the dispute resolution provisions.

The IPA must be approved through Board action and returned to the Fund. Your organization may take one of following approaches related to the new IPA:

- Seek authorization from your Board of Trustees and return the executed IPA to the TASB Risk Management Fund at tasbrmf@tasbrmf.org no later than May 13, 2022. A countersigned copy will be returned to you for your records.
- Take no action. The IPA will go into effect May 1, 2022, and your current coverage will continue under the terms of the new IPA. However, your next renewal proposal for Fund coverage will require a board-approved executed IPA unless you terminate coverage at that time.
- Terminate coverage in all Fund programs effective April 30, 2022, by providing written notice of termination to the Fund by April 29, 2022.

Please reach out to your TASB Risk Management Marketing Consultant for assistance with this process. We thank you for your membership in the TASB Risk Management Fund. We are very



proud of our 48-year record of proven strength, stability, and service to Texas public school districts and other educational entities and look forward to our continued partnership.

Sincerely,

A handwritten signature in black ink that reads "Dubravka H. Romano". The signature is written in a cursive, slightly slanted style.

Dubravka H. Romano
Associate Executive Director
Risk Management Services
Texas Association of School Boards, Inc.

CC: Joel Garcia
Adrian Pena (Adrian.Pena@tasb.org)

Attachments: Frequently Asked Questions and Explanation of Changes, Amended Interlocal Participation Agreement

TASB RISK MANAGEMENT FUND INTERLOCAL PARTICIPATION AGREEMENT

Pursuant to the Texas Interlocal Cooperation Act, Chapter 791 of the Texas Government Code, this Interlocal Participation Agreement (Agreement) is entered into by and between the Texas Association of School Boards Risk Management Fund (Fund) and the undersigned local government of the State of Texas (Fund Member). The Fund is an administrative agency of local governments (Fund Members) that cooperate in performing administrative services and governmental functions relative to risk management.

TERMS AND CONDITIONS

In consideration of the mutual covenants and conditions contained in this Agreement and other good and valuable consideration, including, without limitation, the agreement of the Fund and Fund Members to provide risk management programs as detailed in this Agreement, the receipt and sufficiency of which are hereby acknowledged, Fund Member and the Fund, intending to be legally bound, and subject to the terms, conditions, and provisions of this Agreement, agree as follows:

1. **Authority.** Fund Member hereby approves and adopts the Restatement of Interlocal Agreement, dated May 20, 1997, which restated the Interlocal Agreement dated July 2, 1974, establishing the predecessor of the Fund. The Restatement of Interlocal Agreement is incorporated into this Agreement by reference and is available from the Fund upon request. This Agreement serves to outline the relationship between the Fund and Fund Member. While the Texas Interlocal Cooperation Act provides the overarching basis for the Fund, certain Fund programs are further authorized pursuant to various statutes, such as Chapter 504 of the Texas Labor Code, pertaining to workers' compensation; and Chapter 2259, Subchapter B, of the Texas Government Code, pertaining to other risks or hazards.
2. **Program Participation.** This Agreement enables Fund Member to participate in one or more of the Fund's available programs. Because this is an enabling Agreement, Fund Member must also execute a separate Contribution and Coverage Summary (CCS) for each Fund program from which it seeks coverage and/or administrative services. Only a valid CCS will confer the right to participate in a specific program and each CCS shall be incorporated into this Agreement. Through participation in any Fund program, Fund Member waives none of its immunities and authorizes the Fund, or its designee, to assert such immunities on its behalf and on behalf of the Fund or its designee.
3. **Term of Agreement.** This Agreement shall be effective from the date of the last signature below and shall remain in effect unless terminated as provided in this Agreement. This Agreement will automatically terminate if Fund Member ceases to participate in at least one of the Fund's programs (due to the expiration of a CCS participation term or the valid termination of same) or fails to meet the membership qualifications of the Fund as provided in this Agreement and as determined by the Fund in writing.
4. **Termination.** Unless this Agreement is automatically terminated as described above, this Agreement, and/or any component CCS applicable to Fund Member, can be terminated as set forth below. However, unless specifically required in a CCS, the termination of any single Fund program under a CCS shall not also result in the automatic termination of another pending CCS, or this enabling Agreement if any other CCS is still in force for Fund Member. Rather, each Fund program can only be terminated as provided in this Agreement.
 - a. **By Either Party with 30 Days Notice before Renewal.** Any CCS may be terminated by either party with termination to be effective on any successive renewal date by giving written notice to the other party no later than 30 days prior to automatic renewal.
 - b. **By Fund Member upon Payment of Late Notice Fee.** If Fund Member fails to terminate a CCS as provided above, it may still terminate participation in any Fund program prior to the renewal date by paying a late notice fee as herein provided. If Fund Member terminates the CCS before the renewal date, but with fewer than 30 days' advance written notice, Fund Member agrees to pay the Fund a late notice fee in the amount of 25% of the annual contribution for the expiring participation term. Fund Member expressly acknowledges that the late notice fee is not a penalty, but a reasonable approximation of the Fund's damages for the Fund Member's untimely withdrawal from the program identified in the CCS. However, once the renewal term of a CCS commences, Fund Member can no longer terminate the CCS by paying a late notice fee; the CCS shall renew and Fund Member must pay 100% of the annual contribution for the renewal period.
 - c. **By the Fund upon Breach by Fund Member.** The Fund may terminate this Agreement or any CCS based on breach of any of the following obligations, by giving 10 days' written notice to Fund Member of the breach; and Fund Member's failure to cure the breach within said 10 days (or other time period allowed by the Fund):
 - 1) Fund Member fails or refuses to make the payments or contributions required by this Agreement;
 - 2) Fund Member fails to cooperate and comply with any reasonable requests for information and/or records made by the Fund;

- 3) Fund Member fails or refuses to follow loss prevention or statutory compliance requirements of the Fund, as provided in this Agreement; or
- 4) Fund Member otherwise breaches this Agreement.

If the Fund terminates this Agreement, or any CCS, based on breach as described above, Fund Member agrees that the Fund will have no responsibility of any kind or nature to provide coverage on the terminated Fund program post-termination. Further, Fund Member shall bear the full financial responsibility for any unpaid open claim and expense related to any claim, asserted or unasserted and reported or unreported, against the Fund or Fund Member, or incurred by the agents or representatives of Fund Member.

In addition to the foregoing, if termination is due to Fund Member's failure to make required payments or contributions, Fund Member agrees that it shall pay the Fund liquidated damages in the amount of 50% of the annual contribution for the participation term identified in the terminated CCS.

5. Contributions.

- a. **Agreement to Pay Contribution.** Fund Member agrees to pay its contribution for each Fund program in which it participates based on a plan developed by the Fund. The amount of contribution will be stated in the relevant CCS and will be payable upon receipt of an invoice from the Fund. Late fees amounting to the maximum interest allowed by law, but not less than the rate of interest authorized under Chapter 2251, Texas Government Code, shall begin to accrue daily on the first day following the due date and continue until the contribution and late fees are paid in full. If Fund Member fails to pay the amounts due under this Agreement, including any CCS, the Fund may redirect other amounts due to the Fund Member, payments received from Fund Member, or amounts held by the Fund for Fund Member's benefit, to offset the amount owed. Any offset will not extinguish Fund Member's obligation for any and all payments due under this Agreement, including any CCS.
- b. **Other Payments Due to the Fund.** In addition to contributions, if the Fund Member owes other payments to the Fund, such as deductibles or claim overpayments, and Fund Member fails to timely pay the amounts due, the Fund may redirect other amounts due to the Fund Member, payments received from Fund Member, or amounts held by the Fund for the Fund Member's benefit to offset the amounts owed.
- c. **Estimated Contribution and Contribution Adjustment.** In specified situations, the amount of contribution shown in the CCS will be identified as an estimate. The Fund reserves the right to request an audit of updated exposure information at the end of the CCS participation term and adjust contributions if Fund Member's exposure changes during the CCS participation term. As a result of the exposure review, any additional contribution payable to the Fund shall be paid by Fund Member, and any overpayment of contribution by Fund Member shall be returned or credited by the Fund. The Fund reserves the right to audit the relevant records of Fund Member in order to conduct this exposure review.

Upon expiration of each participation period, Fund Member may request a contribution adjustment due to exposure changes. Such request must be made in writing within 60 days after the end of the participation period. Fund Member must provide documentation as requested by the Fund to demonstrate that the exposure change warrants a contribution adjustment.

The annual contribution may be adjusted due to an exposure change or audit as presented in the CCS. The Fund may also request a contribution adjustment should the Fund's underwriting income for any program within a given program year be inadequate to pay the ultimate cost of claims incurred for that year, the Fund may collect an adjusted contribution from any current or former Fund Member if that Fund Member's contribution is inadequate to pay the Fund Member's claims incurred during that year.

6. **Contribution and Coverage Summary.** Fund Member agrees to abide by each CCS that governs its participation. A CCS will incorporate the program specific coverage document, if any, which sets forth the scope of coverage and/or services from the Fund. This Agreement will be construed to incorporate the CCS, Coverage Agreements, Endorsements, and Addenda, if any, whether or not physically attached. A CCS for a Fund program will state the participation term. After Fund Member's execution of a CCS, the CCS will automatically renew annually, unless terminated in accordance with this Agreement. Any renewal containing a change in the amount of contribution or other terms will be subject to the Amendment by Notice process described in this Agreement.
7. **Loss Prevention.** The Fund may provide loss prevention services to Fund Member. Fund Member agrees to adopt the Fund's reasonable and customary standards for loss prevention and to cooperate in implementing any and all reasonable loss prevention and statutory compliance recommendations or requirements. The Fund makes no warranty on Fund loss prevention recommendations.

8. Other Duties of Fund Member.

- a. **Standards of Performance.** Time shall be of the essence in Fund Member's reporting of any and all claims to the Fund, payment of any contributions or monies due to the Fund, and delivery of any written notices under this Agreement.
- b. **Claims Reporting.** Notice of any claim must be provided to the Fund as required by law or the applicable Coverage Agreement. Failure by Fund Member to timely report a claim may result in denial of coverage or payment of fines or penalties imposed by law or regulatory agencies. If the Fund advances payment of any fine or penalty arising from Fund Member's late claim reporting, Fund Member will reimburse the Fund for all such costs.
- c. **Cooperation and Access.** Fund Member agrees to cooperate and to comply in a timely manner with all reasonable requests for access, information and/or records made by the Fund or by a third-party acting for the Fund. Fund Member further agrees to provide complete and accurate statements of material facts, to not misrepresent or omit such facts, or make false statements to the Fund. The Fund Member agrees that any information held by the Fund's Administrator, or its' affiliated entities may be provided to the Fund. The Fund reserves the right to audit the relevant records of Fund Member to determine compliance with this Agreement.

9. **Administration of Claims.** The Fund or its designee agrees to administer all claims for which Fund Member has coverage after Fund Member provides timely written notice to the Fund. Fund Member hereby authorizes the Fund or its designee to act in all matters pertaining to handling of claims for which Fund Member has coverage pursuant to this Agreement. Fund Member expressly agrees that the Fund has sole authority in all matters pertaining to the administration of claims and grants the Fund or its designee full decision-making authority in all matters, including without limitation, discussions with claimants and their attorneys or other duly authorized representatives. Fund Member further agrees to be fully cooperative in supplying any information reasonably requested by the Fund in the handling of claims. All decisions on individual claims shall be made by the Fund or its designee, including, without limitation, decisions concerning claim values, payment due on the claim, settlement, subrogation, litigation, or appeals.

10. **Excess Coverage/Reinsurance.** The Fund, in its sole discretion, may purchase excess coverage or reinsurance for any or all Fund programs. In the event of a substantial change in terms or cost of such coverage, the Fund reserves the right to make adjustments to the terms and conditions of a CCS as allowed by the Amendment by Notice process under this Agreement. If any reinsurer, stop loss carrier, and/or excess coverage provider fails to meet its obligations to the Fund or any Fund Member, the Fund is not responsible for any payment or any obligations to Fund Member from any reinsurer, stop loss carrier, or excess coverage provider.

11. Subrogation and Assignment of Rights.

- a. Fund Member, on its own behalf and on behalf of any person entitled to benefits under this Agreement, assigns all subrogation rights to the Fund. The Fund has the right, in its sole discretion, without notice to Fund Member, to bring all claims and lawsuits in the name of Fund Member or the Fund. Fund Member agrees that all subrogation rights and recoveries belong first to the Fund, up to the amount of benefits, expenses, and attorneys' fees incurred by the Fund, with the balance, if any, being paid to Fund Member, unless otherwise specifically stated in the Agreement. Award of funds to any person entitled to coverage, whether by judgment or settlement, shall be conclusive proof that the injured party has been made whole. Fund Member's right to be made whole is expressly superseded by the Fund's subrogation rights. If Fund Member procures alternate coverage for a risk covered by the Fund, the latter acquired coverage shall be deemed primary coverage concerning that risk.
- b. Fund Member shall do nothing to prejudice or waive the Fund's existing or prospective subrogation rights under this Agreement. If Fund Member has waived any subrogation right without first obtaining the Fund's written approval, the Fund shall be entitled to recover from Fund Member any sums that it would have been able to recover absent such waiver. Recoverable amounts include attorneys' fees, costs, and expenses.

12. **Appeals.** Fund Member shall have the right to appeal any written decision or recommendation to the Fund's Board of Trustees, and the Board's determination will be final. Any appeal shall be made in writing to the Board Chair within 30 days of the decision or recommendation.

13. **Bylaws, Policies, and Procedures.** Fund Member agrees to abide by the Bylaws of the Fund, as they may be amended from time to time, and any and all written policies and procedures established by the Fund (which are available from the Fund upon written request). If a change is made to the Fund's Bylaws, written policies or procedures which conflicts with or impairs a CCS, such change will not apply to Fund Member until the renewal of such CCS, unless Fund Member specifically agrees otherwise.

14. **Payments.** Fund Member represents and warrants that all payments required under this Agreement of Fund Member shall be made from its available current revenues.

15. **Fund Member's Designation of Coordinator.** Fund Member agrees to designate an employee with appropriate authority as coordinator (Program Coordinator) for Fund Member on this Agreement or any CCS executed by Fund Member. Fund Member's Program Coordinator shall have express authority to represent and to bind Fund Member, shall fully communicate with the Fund regarding Fund business, and shall not delegate this communication to a third party. The Fund will not be required to contact any other individual regarding matters arising from or related to this Agreement. Fund Member reserves the right to change its Program Coordinator as needed, by giving written notice to the Fund; such notice is not effective until actually received by the Fund. Notice provided to the Chief Executive Officer of Fund Member shall also serve as notice to the Program Coordinator.
16. **Risk Sharing Agreement.** This Agreement is a risk sharing and risk participation agreement and should not be construed to be a contract of insurance. If any ambiguity exists in this Agreement, including any CCS or specific coverage document, the provision shall not be construed against the Fund as drafter of this Agreement. The Fund is not an insurance company nor is any member an insured. The Fund is a self-insured risk pool through which its members agree to share risk and actively participate in their contractual obligations to lessen risk and cost for all members. Any reference in this Agreement to an insurance term or concept is coincidental, is not intended to characterize the Fund as "insurance" as defined by law, shall be deemed to apply to self-insurance, and is not to be construed as being contrary to the self-insurance concept.
17. **Representation.** Fund Member authorizes the Fund to represent Fund Member in any lawsuit, dispute, or proceeding arising under or relating to any Fund program and/or coverage in which Fund Member participates. The Fund may exercise this right in its sole discretion and to the fullest extent permitted or authorized by law. Fund Member shall fully cooperate with the Fund, its designee, and the Fund's chosen counsel, including, without limitation, supplying any information necessary or relevant to the lawsuit, dispute, or proceeding in a timely fashion. Subject to specific revocation, Fund Member designates the Fund to act as a class representative on its behalf in matters arising out of this Agreement.
18. **Members' Equity.** The Fund Board, in its sole discretion, may declare a distribution of the Fund's members' equity to Fund Members. Members' equity belongs to the Fund. No current or former individual Fund Member is entitled to an individual allocation or portion of members' equity.
19. **Entire Agreement.** This Agreement, together with the Restated Interlocal Agreement, Bylaws, CCSs, and Coverage Agreements that are in effect as to Fund Member from time to time, represent and contain the complete understanding and agreement of the Fund and Fund Member, and there are no representations, agreements, arrangements, or undertakings, oral or written, between the Fund and Fund Member other than those set forth in this Agreement duly executed in writing. In the event of conflict between the terms of this Agreement and the Restated Interlocal Agreement, Bylaws, CCS, or any Coverage Agreement, the specific terms of the later adopted agreement shall prevail to the extent necessary to resolve the conflict. This Agreement replaces all previous Interlocal Participation Agreements between the Fund and Fund Member. Notwithstanding the foregoing, this Agreement does not supersede any unexpired participation term or pending claim under an existing agreement between Fund Member and Fund.
20. **Amendment by Notice.** This Agreement, including any of its component CCSs or coverage documents, may be amended by the Fund, in writing, by providing Fund Member with written notice before the earlier of (i) the effective date of the amendment or (ii) the date by which Fund Member can terminate without payment of late notice fees or liquidated damages. Unless this Agreement expressly provides otherwise, an amendment shall only apply prospectively and Fund Member shall have the right to terminate this Agreement, or a component CCS to which the amendment applies, before the amendment becomes effective, as provided in this Agreement. If Fund Member fails to give the Fund timely written notice of termination, Fund Member shall be deemed to have consented to the Fund's amendment and agrees to abide by and be bound by the amendment, without necessity of obtaining Fund Member's signature.

The Fund may amend this Agreement or any CCS effective upon renewal. Amendments may be for any reason including changes to the terms or contribution amount.

The Fund may also amend this Agreement or any CCS, effective during the term of a CCS, for any reason including but not limited to the following:

- a. State or federal governments, including any court, regulatory body, or agency thereof, adopt a statute, rule, decision, or take any action that would substantially impact the rights or financial obligations of the Fund as it pertains to this Agreement, or any Fund program or CCS.
- b. The terms of the Fund's stop-loss or excess coverage or reinsurance change substantially.

If the Fund exercises the option to amend the Agreement or any CCS during the term of a CCS and prior to renewal, the Fund shall give Fund Member 30 days advance written notice. Fund Member will then have the right during the 30-day period to give the Fund written notice of termination of the applicable Fund program, effective upon the expiration of the 30-day notice period (or longer period if so provided by the Fund in writing).

21. **Severability; Interpretation.** If any portion of this Agreement shall be declared illegal or held unenforceable for any reason, the remaining portions shall continue in full force and effect. Any questions of particular interpretation shall not be interpreted against the drafter of this Agreement, but rather in accordance with the fair meaning thereof.
22. **Dispute Resolution.** This Agreement shall be governed by and construed in accordance with the laws of the State of Texas, without regard to conflict of law principles that would require the application of the laws of another state. The Fund retains its governmental immunity except to the extent it is waived by the legislature. The parties agree that the following adjudication procedures apply to any legal dispute, and that the Fund Member's right to file suit against the Fund is contingent upon compliance with these procedures pursuant to Texas Local Government Code section 271.154:
- Prior to filing suit, the Fund Member must comply with all of its obligations under this Agreement and any specific Coverage Agreement including an appeal to the Fund Board as described by Section 12 of this Agreement. A good-faith appeal to the Fund Board is a pre-suit adjudication procedure that is required before litigation by a Fund Member against the Fund.
 - Prior to filing suit, the Fund Member will participate in good faith in mediation in Travis County, Texas before a mediator approved by both parties; and
 - Any suit against the Fund must be brought in Travis County, Texas.

In the event of a lawsuit or formal adjudication between Fund Member and the Fund, the prevailing party is entitled to recover reasonable and necessary attorneys' fees and expenses, including expert fees, that are equitable and just.

Waiver and Estoppel. No provision of this Agreement will be deemed waived by either party unless expressly waived in writing by the waiving party. No waiver shall be implied by delay or any other act or omission. No waiver by either party of any provision of this Agreement shall be deemed a waiver of such provision with respect to any subsequent matter relating to such provision. Estoppel may not be asserted against either party so as to prevent that party from enforcing or insisting on the other party's compliance with any provision of this Agreement.

Assignment. This Agreement or any duties or obligations imposed by this Agreement shall not be assignable by Fund Member without the prior written consent of the Fund. Fund Member shall not transfer any interest in Fund claim related payments to any third party, including, but not limited to litigation finance companies, attorneys, banks, public adjusters, architects, engineers, or contractors. Any action by the Fund Member which grants or attempts to grant to any third party an interest in or control over any claim payment, including, but not limited to, the Member's entry into a contingent fee contract, will immediately suspend any obligation by the Fund to make any claim payment under this Agreement. The obligation of the Fund to make any such claim payments shall not be restored unless and until the Fund Member provides the Fund with evidence reasonably satisfactory to the Fund that any such transfer or attempt to transfer an interest in or control over such claim payment to a third party has effectively been terminated.

23. **Authorization.** By the execution of this Agreement, the undersigned individuals warrant that they have been authorized by all requisite governance action to enter into and to perform the terms and conditions of this Agreement and that the Fund Member authorizes the Program Coordinator or Chief Executive Officer to approve and bind the Fund Member to any current or future CCS entered into under this Agreement
24. **Notice.** Unless expressly stated otherwise in this Agreement, any notice required or provided under this Agreement by either party to the other party shall be in writing and shall be sent by first class mail, postage prepaid or by a carrier for overnight service or by electronic means typically used in commerce. Notice to the Fund shall be sufficient if made or addressed as follows: TASB Risk Management Fund, P.O. Box 301, Austin, Texas 78767-0301, or tasbrmf@tasbrmf.org. The Fund's required notice address may be updated through explicit written or electronic notice to Fund Members. Notice to a Fund Member shall be sufficient if addressed to the Program Coordinator or Fund Member's Chief Executive Officer and mailed to Fund Member's physical or electronic address of record on file with the Fund.
25. **Miscellaneous.** These provisions apply throughout this Agreement:
- Fund reference.** Any reference to the Fund in this Agreement includes reference to its designees.
 - CCS reference.** References to a Contribution and Coverage Summary (CCS) includes a reference to all separate coverage portions of a CCS and/or any similar service agreement between the Fund and a Fund Member.
 - "Including."** Unless the context requires otherwise, the term "including" means "including but not limited to."
 - Successors.** This Agreement binds and inures to the benefit of the parties and their successors.
 - Headings.** The headings are for convenience only and do not affect the interpretation of this Agreement.

26. **Signatures/Counterparts.** The failure of a party to provide an original, manually executed signature to the other party shall not affect the validity or enforceability of this Agreement. Either party may rely upon a facsimile or imaged signature as if it were an original. This Agreement may be executed in several separate counterparts, each of which shall be an original and all of which shall constitute one and the same instrument.

WHEREFORE, the parties agree to be bound by this Agreement by signing below.

For FUND MEMBER: **Mission CISD**

By: _____

Date: _____

Signature of Fund Member's Authorized Representative

Printed Name of Fund Member's Authorized Representative

Date approved by Fund Member's Board of Trustees: _____

For TASB Risk Management Fund Use Only

For TASB RISK MANAGEMENT FUND:

By: _____

Date: _____

Chair, TASB Risk Management Fund Board of Trustees

SUBJECT: Approval of Contract Renewal for Independent Financial Audit Services

PRESENTER: Joel Garcia, Assistant Superintendent for Finance

BACKGROUND INFORMATION

Texas School Districts are required to be audited by an external firm annually. Auditing requirements for Texas public school districts are contained in the Texas Education Agency's Financial Accountability System Resource Guide, which is the authoritative document adopted by reference as a rule of the State Board of Education, through Title 19, Texas Administrative Code, Section 109.41.

The District-wide audit will encompass the basic financial statements, combining statements and other schedules for the District for the fiscal year ending June 30, 2022. The audit is to be performed in accordance with generally accepted government auditing standards contained in the Texas Education Agency Financial Accountability System Resource Guide.

ADMINISTRATIVE CONSIDERATIONS

At the April 8, 2020 Regular Board Meeting, the Board of Trustees awarded Carr Riggs & Ingram, LLC a contract for one year (1) with the option to extend the contract for two additional one (1) year terms through fiscal year 2021-2022, following satisfactory delivery of the services specified in the proposal and engagement letter.

This is the third year of the 3 year financial audit services contract.

FUNDING SOURCE AND AMOUNT

General Fund estimated \$55,000

RECOMMENDATION

Approval of Contract Renewal for Independent Financial Audit Services

CONTACT PERSONS

Joel Garcia, Assistant Superintendent for Finance
Rebecca Magee, CPA, Internal Auditor
Anna M. Zuniga, CPA, Director of Accounting

March 23, 2022

To the Board of Trustees and Management
Mission Consolidated Independent School District
Mission, TX 78572

We are pleased to confirm our understanding of the services we are to provide for Mission Consolidated Independent School District (the “District”) for the year ended June 30, 2022.

Audit Scope and Objectives

We will audit the financial statements of the governmental activities, each major fund, and the aggregate remaining fund information, including the disclosures, which collectively comprise the basic financial statements, of Mission Consolidated Independent School District as of and for the year ended June 30, 2022. Accounting standards generally accepted in the United States of America (GAAP) provide for certain required supplementary information (RSI), such as management’s discussion and analysis (MD&A), to supplement the District’s basic financial statements. Such information, although not a part of the basic financial statements, is required by the Governmental Accounting Standards Board who considers it to be an essential part of financial reporting for placing the basic financial statements in an appropriate operational, economic, or historical context. As part of our engagement, we will apply certain limited procedures to the District’s RSI in accordance with auditing standards generally accepted in the United States of America (GAAS). These limited procedures will consist of inquiries of management regarding the methods of preparing the information and comparing the information for consistency with management’s responses to our inquiries, the basic financial statements, and other knowledge we obtained during our audit of the basic financial statements. We will not express an opinion or provide any assurance on the information because the limited procedures do not provide us with sufficient evidence to express an opinion or provide any assurance. The following RSI is required by GAAP and will be subjected to certain limited procedures, but will not be audited:

- 1) Management’s Discussion and Analysis.
- 2) General Fund – Budgetary Comparison Schedule.
- 3) Schedule of the District’s Proportionate Share of the Net Pension and OPEB Liability – Teacher Retirement System of Texas (TRS).
- 4) Schedule of District’s Contributions for Pension and OPEB – Teacher Retirement System of Texas (TRS).
- 5) Notes to Required Supplementary Information.

We have also been engaged to report on supplementary information other than RSI that accompanies the District's financial statements. We will subject the following supplementary information to the auditing procedures applied in our audit of the financial statements and certain additional procedures, including comparing and reconciling such information directly to the underlying accounting and other records used to prepare the financial statements or to the financial statements themselves, and other additional procedures in accordance with GAAS, and we will provide an opinion on it in relation to the financial statements as a whole in a report combined with our auditors' report on the financial statements.

- 1) Combining Fund Statements
- 2) Other Supplementary Information as required by the Texas Education Agency.
- 3) Schedule of Expenditures of Federal Awards.
- 4) Schedule of Required Responses to Selected School FIRST indicators.

In connection with our audit of the basic financial statements, we will read the following other information and consider whether a material inconsistency exists between the other information and the basic financial statements, or the other information otherwise appears to be materially misstated. If, based on the work performed, we conclude that an uncorrected material misstatement of the other information exists, we are required to describe it in our report.

- 1) Introductory Section
- 2) Statistical Section

The objectives of our audit are to obtain reasonable assurance about whether the financial statements as a whole are free from material misstatement, whether due to fraud or error, and issue an auditors' report that includes our opinions about whether your financial statements are fairly presented, in all material respects, in conformity with GAAP, and report on the fairness of the supplementary information referred to in the second paragraph when considered in relation to the financial statements as whole. Reasonable assurance is a high level of assurance but is not absolute assurance and therefore is not a guarantee that an audit conducted in accordance with GAAS and *Government Auditing Standards* will always detect a material misstatement when it exists. Misstatements, including omissions, can arise from fraud or error and are considered material if there is a substantial likelihood that, individually or in the aggregate, they would influence the judgment of a reasonable user made based on the financial statements. The objectives also include reporting on:

- Internal control over financial reporting and compliance with provisions of laws, regulations, contracts, and award agreements, noncompliance with which could have a material effect on the financial statements in accordance with *Government Auditing Standards*.
- Internal control over compliance related to major programs and an opinion (or disclaimer of opinion) on compliance with federal statutes, regulations, and the terms and conditions of federal awards that could have a direct and material effect on each major program in accordance with the Single Audit Act Amendments of 1996 and Title 2 U.S. *Code of Federal Regulations* (CFR) Part 200, *Uniform Administrative Requirements, Cost Principles, and Audit Requirements for Federal Awards* (Uniform Guidance).

Auditors' Responsibilities for the Audit of the Financial Statements and Single Audit

We will conduct our audit in accordance with GAAS; the standards for financial audits contained in *Government Auditing Standards*, issued by the Comptroller General of the United States; the Single Audit Act Amendments of 1996; and the provisions of the Uniform Guidance, and will include tests of accounting records, a determination of major program(s) in accordance with Uniform Guidance, and other procedures we consider necessary to enable us to express such opinions. As part of an audit in accordance with GAAS and *Government Auditing Standards*, we exercise professional judgment and maintain professional skepticism throughout the audit.

We will evaluate the appropriateness of accounting policies used and the reasonableness of significant accounting estimates made by management. We will also evaluate the overall presentation of the financial statements, including the disclosures, and determine whether the financial statements represent the underlying transactions and events in a manner that achieves fair presentation. We will plan and perform the audit to obtain reasonable assurance about whether the financial statements are free of material misstatement, whether from (1) errors, (2) fraudulent financial reporting, (3) misappropriation of assets, or (4) violations of laws or governmental regulations that are attributable to the government or to acts by management or employees acting on behalf of the government. Because the determination of waste and abuse is subjective, *Government Auditing Standards* do not expect auditors to perform specific procedures to detect waste or abuse in financial audits nor do they expect auditors to provide reasonable assurance of detecting waste or abuse.

Because of the inherent limitations of an audit, combined with the inherent limitations of internal control, and because we will not perform a detailed examination of all transactions, there is an unavoidable risk that some material misstatements or noncompliance may not be detected by us, even though the audit is properly planned and performed in accordance with GAAS and *Government Auditing Standards*. In addition, an audit is not designed to detect immaterial misstatements or violations of laws or governmental regulations that do not have a direct and material effect on the financial statements or on major programs. However, we will inform the appropriate level of management of any material errors, any fraudulent financial reporting, or misappropriation of assets that come to our attention. We will also inform the appropriate level of management of any violations of laws or governmental regulations that come to our attention, unless clearly inconsequential. We will include such matters in the reports required for a Single Audit. Our responsibility as auditors is limited to the period covered by our audit and does not extend to any later periods for which we are not engaged as auditors.

We will also conclude, based on the audit evidence obtained, whether there are conditions or events, considered in the aggregate, that raise substantial doubt about the government's ability to continue as a going concern for a reasonable period of time.

Our procedures will include tests of documentary evidence supporting the transactions recorded in the accounts, tests of the physical existence of inventories, and direct confirmation of receivables and certain assets and liabilities by correspondence with selected individuals, funding sources, creditors, and financial institutions. We will also request written representations from your attorneys as part of the engagement.

We have identified the following significant risks of material misstatement as part of our audit planning:

- Management override of controls
- Improper revenue recognition due to fraud

Please note that planning has not concluded and modifications may be made.

Audit Procedures—Internal Control

We will obtain an understanding of the government and its environment, including internal control relevant to the audit, sufficient to identify and assess the risks of material misstatement of the financial statements, whether due to error or fraud, and to design and perform audit procedures responsive to those risks and obtain evidence that is sufficient and appropriate to provide a basis for our opinions. The risk of not detecting a material misstatement resulting from fraud is higher than for one resulting from error, as fraud may involve collusion, forgery, intentional omissions, misrepresentation, or the override of internal control. Tests of controls may be performed to test the effectiveness of certain controls that we consider relevant to preventing and detecting errors and fraud that are material to the financial statements and to preventing and detecting misstatements resulting from illegal acts and other noncompliance matters that have a direct and material effect on the financial statements. Our tests, if performed, will be less in scope than would be necessary to render an opinion on internal control and, accordingly, no opinion will be expressed in our report on internal control issued pursuant to *Government Auditing Standards*.

As required by the Uniform Guidance, we will perform tests of controls over compliance to evaluate the effectiveness of the design and operation of controls that we consider relevant to preventing or detecting material noncompliance with compliance requirements applicable to each major federal award program. However, our tests will be less in scope than would be necessary to render an opinion on those controls and, accordingly, no opinion will be expressed in our report on internal control issued pursuant to the Uniform Guidance.

An audit is not designed to provide assurance on internal control or to identify significant deficiencies or material weaknesses. Accordingly, we will express no such opinion. However, during the audit, we will communicate to management and those charged with governance internal control related matters that are required to be communicated under AICPA professional standards, *Government Auditing Standards*, and the Uniform Guidance.

Audit Procedures—Compliance

As part of obtaining reasonable assurance about whether the financial statements are free of material misstatement, we will perform tests of the District's compliance with provisions of applicable laws, regulations, contracts, and agreements, including grant agreements. However, the objective of those procedures will not be to provide an opinion on overall compliance, and we will not express such an opinion in our report on compliance issued pursuant to *Government Auditing Standards*.

The Uniform Guidance requires that we also plan and perform the audit to obtain reasonable assurance about whether the auditee has complied with federal statutes, regulations, and the terms and conditions of federal awards applicable to major programs. Our procedures will consist of tests of transactions and other applicable procedures described in the *OMB Compliance Supplement* for the types of compliance requirements that could have a direct and material effect on each of the District's major programs. For federal programs that are included in the Compliance Supplement, our compliance and internal control procedures will relate to the compliance requirements that the Compliance Supplement identifies as being subject to audit. The purpose of these procedures will be

to express an opinion on the District's compliance with requirements applicable to each of its major programs in our report on compliance issued pursuant to the Uniform Guidance.

Responsibilities of Management for the Financial Statements and Single Audit

Our audit will be conducted on the basis that you acknowledge and understand your responsibility for (1) designing, implementing, establishing, and maintaining effective internal controls relevant to the preparation and fair presentation of financial statements that are free from material misstatement, whether due to fraud or error, including internal controls over federal awards, and for evaluating and monitoring ongoing activities to help ensure that appropriate goals and objectives are met; (2) following laws and regulations; (3) ensuring that there is reasonable assurance that government programs are administered in compliance with compliance requirements; and (4) ensuring that management and financial information is reliable and properly reported. Management is also responsible for implementing systems designed to achieve compliance with applicable laws, regulations, contracts, and grant agreements. You are also responsible for the selection and application of accounting principles; for the preparation and fair presentation of the financial statements, schedule of expenditures of federal awards, and all accompanying information in conformity with accounting principles generally accepted in the United States of America; and for compliance with applicable laws and regulations (including federal statutes), rules, and the provisions of contracts and grant agreements (including award agreements). Your responsibilities also include identifying significant contractor relationships in which the contractor has responsibility for program compliance and for the accuracy and completeness of that information.

Management is also responsible for making drafts of financial statements, schedule of expenditures of federal awards, all financial records, and related information available to us and for the accuracy and completeness of that information (including information from outside of the general and subsidiary ledgers). You are also responsible for providing us with (1) access to all information of which you are aware that is relevant to the preparation and fair presentation of the financial statements, such as records, documentation, identification of all related parties and all related-party relationships and transactions, and other matters; (2) access to personnel, accounts, books, records, supporting documentation, and other information as needed to perform an audit under the Uniform Guidance; (3) additional information that we may request for the purpose of the audit; and (4) unrestricted access to persons within the government from whom we determine it necessary to obtain audit evidence. At the conclusion of our audit, we will require certain written representations from you about the financial statements; schedule of expenditures of federal awards; federal award programs; compliance with laws, regulations, contracts, and grant agreements; and related matters.

Your responsibilities include adjusting the financial statements to correct material misstatements and confirming to us in the management representation letter that the effects of any uncorrected misstatements aggregated by us during the current engagement and pertaining to the latest period presented are immaterial, both individually and in the aggregate, to the financial statements of each opinion unit taken as a whole.

You are responsible for the design and implementation of programs and controls to prevent and detect fraud, and for informing us about all known or suspected fraud affecting the government involving (1) management, (2) employees who have significant roles in internal control, and (3) others where the fraud could have a material effect on the financial statements. Your responsibilities include informing us of your knowledge of any allegations of fraud or suspected fraud affecting the government received in communications from employees, former employees, grantors, regulators,

or others. In addition, you are responsible for identifying and ensuring that the government complies with applicable laws, regulations, contracts, agreements, and grants. You are also responsible for taking timely and appropriate steps to remedy fraud and noncompliance with provisions of laws, regulations, contracts, and grant agreements that we report. Additionally, as required by the Uniform Guidance, it is management's responsibility to evaluate and monitor noncompliance with federal statutes, regulations, and the terms and conditions of federal awards; take prompt action when instances of noncompliance are identified including noncompliance identified in audit findings; promptly follow up and take corrective action on reported audit findings; and prepare a summary schedule of prior audit findings and a separate corrective action plan.

You are responsible for identifying all federal awards received and understanding and complying with the compliance requirements and for the preparation of the schedule of expenditures of federal awards (including notes and noncash assistance received, and COVID-19-related concepts, such as lost revenues, if applicable) in conformity with the Uniform Guidance. You agree to include our report on the schedule of expenditures of federal awards in any document that contains, and indicates that we have reported on, the schedule of expenditures of federal awards. You also agree to include the audited financial statements with any presentation of the schedule of expenditures of federal awards that includes our report thereon. Your responsibilities include acknowledging to us in the written representation letter that (1) you are responsible for presentation of the schedule of expenditures of federal awards in accordance with the Uniform Guidance; (2) you believe the schedule of expenditures of federal awards, including its form and content, is stated fairly in accordance with the Uniform Guidance; (3) the methods of measurement or presentation have not changed from those used in the prior period (or, if they have changed, the reasons for such changes); and (4) you have disclosed to us any significant assumptions or interpretations underlying the measurement or presentation of the schedule of expenditures of federal awards.

You are also responsible for the preparation of the other supplementary information, which we have been engaged to report on, in conformity with U.S. generally accepted accounting principles. You agree to include our report on the supplementary information in any document that contains, and indicates that we have reported on, the supplementary information. You also agree to include the audited financial statements with any presentation of the supplementary information that includes our report thereon. Your responsibilities include acknowledging to us in the written representation letter that (1) you are responsible for presentation of the supplementary information in accordance with GAAP; (2) you believe the supplementary information, including its form and content, is fairly presented in accordance with GAAP; (3) the methods of measurement or presentation have not changed from those used in the prior period (or, if they have changed, the reasons for such changes); and (4) you have disclosed to us any significant assumptions or interpretations underlying the measurement or presentation of the supplementary information.

Management is responsible for establishing and maintaining a process for tracking the status of audit findings and recommendations. Management is also responsible for identifying and providing report copies of previous financial audits, attestation engagements, performance audits, or other studies related to the objectives discussed in the Audit Scope and Objectives section of this letter. This responsibility includes relaying to us corrective actions taken to address significant findings and recommendations resulting from those audits, attestation engagements, performance audits, or studies. You are also responsible for providing management's views on our current findings,

conclusions, and recommendations, as well as your planned corrective actions for the report, and for the timing and format for providing that information.

With regard to publishing the financial statements on your website, you understand that websites are a means of distributing information and, therefore, we are not required to read the information contained in those sites or to consider the consistency of other information on the website with the original document.

Engagement Administration, Fees, and Other

We understand that your employees will provide audit support that includes preparing confirmations, roll-forward schedules on the balance sheet accounts, reconciliations of material accounts, pulling back-up data for the auditors, providing subsidiary detail records to support financial statement amounts, footnote disclosures, supplementary schedules of the financial statement package, introduction and statistical section.

At the conclusion of the engagement, we will complete the appropriate sections of the Data Collection Form that summarizes our audit findings. It is management's responsibility to electronically submit the reporting package (including financial statements, schedule of expenditures of federal awards, summary schedule of prior audit findings, auditors' reports, and corrective action plan) along with the Data Collection Form to the federal audit clearinghouse. We will coordinate with you the electronic submission and certification. The Data Collection Form and the reporting package must be submitted within the earlier of 30 calendar days after receipt of the auditors' reports or nine months after the end of the audit period.

We will provide copies of our reports to the District; however, management is responsible for distribution of the reports and the financial statements. Unless restricted by law or regulation, or containing privileged and confidential information, copies of our reports are to be made available for public inspection.

The audit documentation for this engagement is the property of Carr, Riggs, & Ingram, LLC and constitutes confidential information. However, subject to applicable laws and regulations, audit documentation and appropriate individuals will be made available upon request and in a timely manner to the Texas Education Agency, a federal agency providing direct or indirect funding, or the U.S. Government Accountability Office for purposes of a quality review of the audit, to resolve audit findings, or to carry out oversight responsibilities. We will notify you of any such request. If requested, access to such audit documentation will be provided under the supervision of Carr, Riggs, & Ingram, LLC personnel. Furthermore, upon request, we may provide copies of selected audit documentation to the aforementioned parties. These parties may intend, or decide, to distribute the copies or information contained therein to others, including other governmental agencies.

The audit documentation for this engagement will be retained for a minimum of five years after the report release date or for any additional period requested by the cognizant agency, oversight agency, or pass-through entity. If we are aware that a federal awarding agency, pass-through entity, or auditee is contesting an audit finding, we will contact the party(ies) contesting the audit finding for guidance prior to destroying the audit documentation.

Esmeralda Yniguez, CPA is the engagement partner and is responsible for supervising the engagement and signing the reports or authorizing another individual to sign them.

Our fees are based on the time required by the individuals assigned to the engagement plus direct expenses. Individual hourly rates vary according to the degree of responsibility involved and the skill required. Interim billings will be submitted as work progresses and as expenses are incurred. Our estimated fee for the services described in this letter will be \$55,000 (including up to two major programs to be tested for controls and compliance) unless the scope of the engagement is changed, the assistance which the District has agreed to furnish is not provided, or unexpected conditions are encountered, in which case we will discuss the situation with District's management and arrive at a new fee estimate before we incur the additional costs. Also, additional consultation and audit time regarding implementation of new accounting principles, other pronouncements is not included in this base fee estimated and will be subject to additional fees at our standard rates based on the time required by the individual according to the degree of responsibility involved and skill required. Our invoices for these fees will be rendered each month as work progresses and are payable on presentation. If we elect to terminate our services for nonpayment, our engagement will be deemed to have been completed upon written notification of termination, even if we have not completed our reports. You will be obligated to compensate us for all time expended and to reimburse us for all out-of-pocket costs through the date of termination.

Reporting

We will issue written reports upon completion of our audit of the District's financial statements. Our reports will be addressed to management and the Board of Trustees of Mission Consolidated Independent School District. Circumstances may arise in which our report may differ from its expected form and content based on the results of our audit. Depending on the nature of these circumstances, it may be necessary for us to modify our opinions, add a separate section, or add an emphasis-of-matter or other-matter paragraph to our auditors' report, or if necessary, withdraw from this engagement. If our opinions are other than unmodified, we will discuss the reasons with you in advance. If, for any reason, we are unable to complete the audit or are unable to form or have not formed opinions, we may decline to express opinions or issue reports, or we may withdraw from this engagement.

The *Government Auditing Standards* report on internal control over financial reporting and on compliance and other matters will state that (1) the purpose of the report is solely to describe the scope of testing of internal control and compliance and the results of that testing, and not to provide an opinion on the effectiveness of the entity's internal control or on compliance, and (2) the report is an integral part of an audit performed in accordance with *Government Auditing Standards* in considering the entity's internal control and compliance. The Uniform Guidance report on internal control over compliance will state that the purpose of the report on internal control over compliance is solely to describe the scope of testing of internal control over compliance and the results of that testing based on the requirements of the Uniform Guidance. Both reports will state that the report is not suitable for any other purpose.

Dispute Resolution

In the event of a dispute between the parties which arises out of or relates to this contract or engagement letter, the breach thereof or the services provided or to be provided hereunder, if the dispute cannot be settled through negotiation, the parties agree that before initiating litigation or other dispute resolution procedure, they will first try, in good faith, to resolve the dispute through non-binding mediation. The mediation will be administered by the American Arbitration Association

under its *Dispute Resolution Rules for Professional Accounting and Related Services Disputes*. The costs of any mediation proceedings shall be shared equally by all parties.

Governing Law; Venue

This agreement and performance hereunder shall be governed by the laws of the State of Texas, without reference to any conflict of laws rules or principles. Any action or proceeding arising from or relating to this agreement must be brought in a state or federal court having jurisdiction in Hidalgo County, Texas, and each party irrevocably submits to the jurisdiction and venue of any such court in any such action or proceeding and agrees to waive any defenses to venue and jurisdiction including *forum non conveniens*.

Disclosure

We may, from time to time and depending on the circumstances, use third-party service providers in serving your account including service providers located outside of the United States. We may share confidential information about you with these service providers, but remain committed to maintaining the confidentiality and security of your information. Accordingly, we maintain internal policies, procedures, and safeguards to protect the confidentiality of your personal information. In addition, we will secure confidentiality agreements with all service providers to maintain the confidentiality of your information and we will take reasonable precautions to determine that they have appropriate procedures in place to prevent the unauthorized release of your confidential information to others. Furthermore, we will remain responsible for the work provided by any such third-party service providers. By signing this letter, you consent to allow us to disclose your financial information, if applicable, or other information to our service providers located abroad. If you want to limit the amount of information that may be disclosed to any third-party service provider, please notify us in writing as an attachment to this letter.

Electronic Data Communication and Storage and Use of Third Party Service Provider

In the interest of facilitating our services to your company, we may send data over the Internet, securely store electronic data via computer software applications hosted remotely on the Internet, or allow access to data through third-party vendors' secured portals or clouds. Electronic data that is confidential to your company may be transmitted or stored using these methods. We may use third-party service providers to store or transmit this data, such as, but not limited to, providers of tax return preparation software. In using these data communication and storage methods, our firm employs measures designed to maintain data security. We use reasonable efforts to keep such communications and data access secure in accordance with our obligations under applicable laws and professional standards. We also require our third-party vendors to do the same.

You recognize and accept that we have no control over, and shall not be responsible for, the unauthorized interception or breach of any communications or data once it has been sent or has been subject to unauthorized access, notwithstanding all reasonable security measures employed by us or our third-party vendors. You consent to our use of these electronic devices and applications and submission of confidential client information to third-party service providers during this engagement.

To enhance our services to you, we will use a combination of remote access, secure file transfer, virtual private network or other collaborative, virtual workspace or other online tools or environments. Access through any combination of these tools allows for on-demand and/or real-time collaboration across geographic boundaries and time zones and allows CRI and you to share data,

engagement information, knowledge, and deliverables in a protected environment. In order to use certain of these tools and in addition to execution of this acknowledgement and engagement letter, you may be required to execute a separate client acknowledgement or agreement and agree to be bound by the terms, conditions and limitations of such agreement. You agree that CRI has no responsibility for the activities of its third-party vendors supplying these tools and agree to indemnify and hold CRI harmless with respect to any and all claims arising from or related to the operation of these tools. While we may back up your files to facilitate our services, you are solely responsible for the backup of your files and records; therefore, we recommend that you also maintain your own backup files of these records. In the event you suffer a loss of any files or records due to accident, inadvertent mistake, or Act of God, copies of which you have provided to us pursuant to this agreement, we shall not be responsible or obligated to provide you a copy of any such file or record which we may retain in our possession.

Conclusion

We appreciate the opportunity to be of service Mission Consolidated Independent School District and believe this letter accurately summarizes the significant terms of our engagement. If you have any questions, please let us know. If you agree with the terms of our engagement as described in this letter, please sign the attached copy and return it to us.

Very truly yours,

Carr, Rigg & Ingram, L.L.C.

RESPONSE:

This letter correctly sets forth the understanding of Mission Consolidated Independent School District.

Board of Trustee Signature
Gerardo Zamora, President

Management Signature
Carolina "Carol" G. Perez, Ed. D.

President of the Board of Trustees
Title

Superintendent of Schools
Title

Joel Garcia, CPM
Finance Division | Assistant Superintendent for Finance
Mission Consolidated Independent School District



Mission Consolidated Independent School District
• 1201 Bryce Drive • Mission, Texas 78572
• Telephone (956) 323-5505 • Fax (956) 323-5634
• Website: www.mcisd.net

Board of Trustees Minutes

The Board of Trustees of the Mission Consolidated Independent School District held a **Regular Meeting on Wednesday, November 10, 2021, at 6:30 PM** in the **Mission CISD Annex, 925 E. Business HWY. 83, Mission, Tx 78572.**

I. Call Meeting to Order and Establish Quorum

President Jerry Zamora called the meeting to order at 6:38 p.m. The meeting was properly posted; a quorum was present. Board Members present besides Jerry Zamora were Petra B. Ramirez, Iris Iglesias, Juan M. Gonzalez, Roy Vela, Minnie Rodgers, Veronica R. Mendoza, and Dr. Carol G. Perez, Superintendent of Schools.

II. Pledge of Allegiance and Moment of Silence

Mr. Jerry Zamora led in the Pledge of Allegiance and he also asked for a Moment of Silence. He stated today is the Marine Corps Birthday, and we think about the men and women who have lost their lives over the years. Thank you.

III. Comments from the Public

Jesus Mendoza made his Public Comments via telephone his topic was an Update on Hypersensitivity. Mr. Jesus Mendoza commented My name is Jesus Mendoza and my phone number is 956-583-7012. This invitation is not intended to be intimidating, harassing, or threatening in any way. This is an invitation to the Superintendent and the Board to verify and use this evidence to protect our children. I have been homebound for more than 10 years with a life-threatening Electro Hypersensitivity. Even low levels of radiation, concerns me among other things vital organs symptoms, heart attack, stroke, rashes on a lot of my skin and memory and speech concentration, and breathing problems. I am in pain all the time. I have been battling my illness several times. This is a horrible way to die. My EHS has been recognized as fatal by courts, as a physical medical condition, and as a disability. EHS has been in proportions children, teachers, doctors, attorneys, and even the director of the World Health Organization are suffering from EHS without knowing thousands if not millions of children are suffering from EHS. Please see we are the evidence.org for that case. The US Department of Education has ignored that microwave radiation is causing children harm and disabilities that defeat the purpose of education. On August 13 of this year in Children's Health defense versus the FCC in response to more than eleven thousand pages of scientific evidence of the widespread sickness caused by microwave radiation the Federal Court ordered the FCC to explain why they ignored this evidence or harm. For more than seven years the mainstream media has ignored the fact that two judges admitted in writing and in their records they fought in court to conceal that most doctors are in the dark or in denial and continue misdiagnosing and mistreating and invasive procedures symptoms that disappear with reduce and exposed radiation and to conceal that on their fabricated excuse of the National Security the future of our children and the future of our country and National Security is being sold to the highest bidder as detailed. On the emergency request to Congress to protect our children posted on the case law section of Jay Mendoza at wireless watch blog.org. Please verify and use this evidence to protect our children and teachers. Thank you very much for listening. Respectfully, Thank you, again.

Jerry Zamora stated Mr. Mendoza I had told you at three minutes and I was wrong. You still have two more minutes. If you like to continue.

Mr. Jesus Mendoza responded okay, thank you. The fraud on the course was also to conceal that government-sponsored health groups, bullying and provoking children, the mentally disabled, and others to commit mass shootings to justify under the fabricated excuses to National Security the massive and harmful military-grade directive radiation surveillance of schools and even homes. Thank you again for listening. Please use this information to protect our children, they cannot defend themselves from this catastrophe. Thank you, sir, thank you to the Board and thank you, Superintendent.

Board Members responded Thank you

IV. Public Comment(s) on a Specific Agenda Item(s)

NONE

V. Superintendent's Updates and Recognitions

Dr. Carol G. Perez, Superintendent, stated for Superintendent's Updates and Recognitions we are going to start with recognitions, knowing this is our favorite part of Board meetings.

Mr. Craig Verley, Director for Public Relations, stated I will admit this evening we are going to be recognizing three students for two very different types of accomplishments in their pursuits in athletics as a student. We are going to begin actually, with a couple of runners who have done very well. We will begin with Veterans Memorial High School where we have a runner there by the name of Danny Alamilla. Danny placed 1st place at the District meets and became our District Champion. He advanced to the State Cross Country Meets during this season. In the State competition, Danny finished first amongst all the runners in his class.

Mr. Verley stated next this evening is a student who also made it to a State Cross Country competition from MHS we would like to recognize Rogelio Aguirre.

Mr. Verley stated this young lady from Mission High School put in a lot of work outside of what she does from school and is going to be competing most recently at the International level. Most recently she was competing at the 2021 International Weightlifting Federation of Youth World Championship in Saudi Arabia. Congratulations to Brianna Marquez for those accomplishments and for finishing 8th in the world.

Mr. Verley stated it's always nice to see what all of our students especially these three and their humble nature present they are very proud of their accomplishments. You see that coming through that they always come forward with such passion. Congratulations to all.

Board Members responded congratulations.

Dr. Carol G. Perez informed the Board of the following: For Superintendent's Updates We've got lots of good things going on in the district and we are very fortunate that we also have our in-house heroes that put out for vaccine clinics last Saturday and targeting our 5 to 11, year olds. However, they also offered boosters and also for adults, but we were able to reach and vaccinate over 400 of our children. We want to thank our staff for collaborating, with Hidalgo County which provided the vaccine vials. Now, the second COVID-19 vaccination clinic for our children will be before the Thanksgiving holidays, through a partnership with TLC Pharmacy and of course our staff have already the schedule and we are beginning this Friday, November 12, 2021, at some Elementary campuses that will be Leal Elementary, Cavazos Elementary, Bryan Elementary, Alton Elementary, and Mims Elementary and it will be from 3:30 to 5:30 p.m. Then on Monday, November 15, 2021, the clinics will be available at Castro Elementary, Salinas Elementary, Waitz Elementary, Pearson Elementary, and O'Grady Elementary. On Tuesday, November 16, 2021, at Cantu Elementary, Midkiff Elementary, Marcel Elementary, Escobar-Rios. On Wednesday, November 17, 2021, at Leal Elementary, Cavazos Elementary, Bryan Elementary, Alton Elementary, and Mims Elementary. On Thursday, November 18, 2021, at Castro Elementary, Salinas Elementary, Waitz Elementary, Pearson Elementary, O'Grady Elementary. On Friday, November 19, 2021, Cantu Elementary, Midkiff Elementary, Marcel Elementary, Escobar-Rios Elementary as well, the time will be 3:30 to 5:30 p.m. and they will be going several times, as you can see to the various campuses to allow parents, the opportunities to bring the children. We also know that many of the local pharmacies are providing them, I believe that we will be also partnering with Richards Pharmacy and just the way we've done in the past. We continue to partner with them. We will continue those efforts until we have reached the point of saturation. We are very grateful that the community has come forward to help us meet the needs of our children, our staff our faculty, and our families. Another item to report is that as promised last Friday, we sent a letter out to our parents that we were going to be utilizing randomly portable metal detectors and we had planned on doing that at the beginning of the school year and that's why we purchase the metal detectors that we did get to use last year in some extracurricular activities. However, because this year we were checking temperatures and we still are we knew it was going to take a lot of time. However, right now is a good time for us to utilize those metal wands and those portable metal detectors. This morning we utilize those wands at Alton Memorial Jr. High. We are also very grateful because various PD departments joined us in that effort Alton PD, the Constable's office as well sent officers. The school was buzzing with exciting things, they also had a bus evacuation drill. They had a lot going on at Alton Memorial Junior High. We will continue with the other schools and randomly either utilize the ones or the portable metal detectors. Also, we have the Capturing Kids Heart staff conducting implementation visits in our schools this week, and what the Consultants do is visit the school's classrooms, they talked to teachers,

and they talked to staff about the lessons that are taking place. Our staff has received lessons workbooks. Things like that to continuously work with our children on social and emotional issues.

In other news just today, there was a program that was done virtually from Children at Risk and this organization looks at schools that are 75% low social-economic or higher every single year and they look at their academic performance and what they do is they acknowledge those schools that are going above and beyond in meeting the needs of the low social economic students in terms of academic achievement this year because of the pandemic, you know that the numbers of students testing were slim, however, they still did something that they're calling the 2021 school rankings Pandemic Edition. So, what they did was they looked at schools the top 10 schools for each level at the state and then by region. Today, I am very happy to report that they looked at the data from 2018 and 2019 and compared it to 2021, because remember there was a year that there were no assessments. So, for the most Resilient Texas middle schools Rafael A. Cantu, Jr. was number ten in the State of Texas. Not only that but also, for the most resilient, Rio Grande Valley Middle School's Rafael Cantu Jr. High was the number four school of the ten selected Region One. Dr. Perez stated that Mr. Torres is here. Mr. Torres, we know that this accolade is not easy to achieve, especially through the pandemic so that family that culture that's being built is lots of work from every individual at the campus every single parent, and every single child. So today we'd like you to stand and if you like to say a few words, we'd like to applaud you and your staff, your community, and your children.

Mr. Torres stated that when the Superintendent says we are flying the plane as we build it, it's true. I think what made the difference for us when we made that list, there are a lot of things that we still need to work on, but there was a focus on instruction and who delivers instruction but the teachers. There was this book many years ago that I read that said don't feed the teacher, they eat the students and what that means is if you want your teachers to provide quality instruction then you need to support them. You need to provide for them. And the model that we have at Rafael Cantu Jr. High is that the mistake is not making mistakes because you learn from your mistakes. The mistake is not allowing you to make those mistakes. To take the challenges to look into doing something different, because you're balancing safety of children, but also their wellbeing. The kids want to interact, they want to be able to socialize. They want to be engaged in activities that are meaningful to them. So, all of that was a challenge doing it online. So, did we make mistakes yes, we did but we learn from those mistakes and that's what made the difference for us? I accept this recognition with a lot of humility and I can't wait to share it with my staff.

Board Members responded with congratulations.

Dr. Perez continued on other news, that we are starting our first fundraiser for the All-Inclusive Lions Park for Central Office Staff. Next week we will have our Instructional Leadership Seminars with campus principals, and we will be rolling out the fundraisers, Mr. Garcia has gone through Ms. Magee to make sure that everything is in order. In meeting with the Executive Leadership Team, we do have various fundraisers that we're going to do at the central office. The first one we're going to kick off next week an email is being sent out to the staff asking them to participate in this fundraiser and they may wear their favorite blue jeans to support the Lions Inclusive Park the week of November 15 through 29th and if they want to wear jeans that week, they can pay \$10 and also the week of December 13 and 17, another \$10 for another week. So, we're excited about that, and the central office will all the Departments that do not wear jeans. We know that maintenance and some of them are allowed to wear jeans. However, all proceeds will be going to playground equipment and Ms. Kim Risica is going to be in charge of that particular fundraiser everybody in the Executive Leadership Team has one specific fund fundraiser or two people are helping so we are going to be rolling out a variety of fundraisers. And then we are going to be asking the campus principals and different departments to do the same because we believe in this project and we're going to support it. We know that the children in our community whether they are special needs or not and the families will be the benefactor. We are more than happy to participate. So, thank you. This is what we have for today.

VI. Presentation(s) to the Board of Trustees

1. Gun Responsibility Awareness Safety Program

Dr. Carol G. Perez stated I have the distinct pleasure of introducing, a very special young man and his name is Roman Camargo, and his mother. This young man reached out to us and as I mentioned to the Board last week, we were looking for resources and things that we could bring at this time for our children and our families, this is a very unique program. It's called GRASP gun responsibility, awareness, and safety program. Roman is 16 years old, but he came up with this program at the age of 13, and his parents have supported him. When we are looking at different programs it's usually, we look at what does the school safety center has for us. What does the service center the County and so forth, but this is a very unique program because it goes to the root of the issue, how to help families by teaching them about gun safety. In our world of Education when a child falls behind or is having issues with academics. We provide interventions, right? We teach we reteach but when it comes to gun responsibility and awareness and safety, it can happen after the fact and I had not come across a program that provides that intensive intervention. In a fun meaningful way for children, and adults, it reaches the heart and the mind. So, what you're going to hear today, I don't think you've ever heard before, so, Roman and your mom

**Mission CISD Board of Trustees Minutes
November 10, 2021
Page 3 of 25**

if you would, please join us and tell us all about your nonprofit organization and what you can do for our children and our community.

Roman Camargo stated thank you very much, my name is Roman Camargo I am the founder of GRASP which is a nonprofit organization geared towards teaching adults and children about gun safety. This is my director.

His mom stated which happens to be his mom. So why are we here today? We are here because the words outside on that big sign says changing the world are not just words. Mission CISD literally wants to change the world for their students and their families. In front of you, you have our logo, if you look carefully it's a Target for gun safety responsibility awareness and we are GRASP. GRASP is a local nonprofit organization. It was founded two years ago when he was 13 years old, from a little idea from a fear, actually, it grew to what it is today. Why should parents and educators support GRASP? Well, one is if you love guns, two if you hate guns, three is if you support safety for, and probably the most important is if you love your children 5 and 6 is children are the future and truly as Educators I know, you know, that knowledge saves lives. Why is it important to educate gun safety? And when we mean gun safety, we do not refer to how to properly hold a gun, or what stand is the right position. We mean how to properly, secure your firearm, how to recognize when there is a threat in the house, an emotional need, an emotional worry of the children going through anxiety, depression, stress. That's what we mean when we say gun safety. What we learn becomes a part of who we are. As Educators again I know you know that what we teach the kids it stays with them and gets embedded in the and as they grow they take that with them. This is very important first of all, the slides you're seeing is not the slides that the children see. I think it's important that everybody knows that this is the one for the adults. After I'm done with this I'll show you what the children will be looking at. We want to convey to mom and dad if there are guns at school, they 100% come from unsecured guns at home. Once Mom and Dad realize that everybody is safer the world becomes automatically safer and we acknowledge and accept that there is a reason a fault, why a gun ended up in a school grounds and regretfully that fault lays on the adult parent, the gun owner who is not a child. This again, children don't see this. If you look at the picture carefully is a child sitting at her own grave. Her dad forgot to lock up his gun, just as a curiosity, kills the cat curiosity, sadly kills children, and complacency is the reason so many disasters are out there today. He found your gun. What happens next is 100% not an accident. It's an incident caused by irresponsibility. It's a sleepover why do we have this here today? Well, because Jeff says moms and dads will ask hey do you guys have your violent vicious dogs in your property? My daughter's going to spend the night. Do your uncle's come over, they just got released from prison. Do you have items that my child's allergic to all the regular Mom and Dad questions we asked to make sure our kids are safe in any environment. We need to do that with guns. I am not asking you, if you're for guns, I'm asking you what is the safety protocol. If you agree, they can stay. If not, they probably shouldn't. This is a very graphic image. If you don't get it. What is it? Guess what the baby found under the dresser, and believe it or not, here in the Rio Grande Valley and we have interviewed so many parents, moms and dads are actually, they actually believe when they go to bed that hiding it under the dresser it's securing a firearm and it is not hiding it under the mattress, under the pillow that is not securing a firearm. Once a toddler finds this there is no turning back. So, why is this up here? We want to make parents understand that it's not just a firearm that is dangerous It's kids, emotional needs. An impulse decision can end up being a fatal one when Firearms are stored in property in the home. That is a bad combination right now, with the pandemic with the economy, the way it is, kids are already going through enough. When you add a firearm in the house, that's a whole other mixture combination that we do not want. Just to give you an idea that I feel for one of our events are events are geared for children for the very bright yellow and red colors, Cowboy Cash, half the people know that he's a mascot for Lone Star Bank the other half, think he's a Dallas Cowboy mascot either way the children love it after the children go over the next slide I'm going to show you they all get awarded that certificate they're holding. It's a very fun educational program and they leave with so much knowledge and more than that, Mom and Dad leave with acknowledgment. Is this dangerous? Yes, No, maybe the answer is 100%. Yes, when I do have the events with a parent you can see dad's physically get uncomfortable because they know that's how they store their gun and that's a very dangerous situation. Just the way kids are late to your class one time, you know, maybe they are late or tardy if you think about it well. They have no control over that they're being dropped off falls on the parents and the same situation here and this is an adult mistake. Here is another event. We get law enforcement. Dr. Perez was kind enough to let us know that Mission CISD contracts with law enforcement. They have their own security so they can provide it. The reason why we have that is very, very important. Social media today has kind of put a way on how to disconnect between children and law enforcement. Any policeman, law enforcement, any type of standing position of authority children for some reason right now are shying away. Now, they are our eyes and ears in school, but when they don't have a relationship good enough to go up to the police or the security guard we're missing out. There's knowledge out there that we don't have to be able to prevent things. So, in our events, we make sure to talk to the security and we want them to smile. We want them to extend their hand. We want them to say hello and take pictures. What we need to do as Educators and adults and leaders is to reform that connection between them and that's the way we make a safer world for kids. This is an important one, if there is anybody in this room that can tell me which is real, and which one is fake? I would love to know. When we asked the children in front of the parents, the parents are shocked. They don't know which one's which. I do because I specifically know which one it exactly is. But think about this moms and dads if your child has this at school and the law enforcement officer had a split second to make a decision. Is he going to second-guess 800 kids in the cafeteria? No, he is not. We want the parents to understand that the toys like this should not be handled. They cannot be in the hands of children. Too many accidents happen and you cannot blame law enforcement when they're faced with that decision. One of those guns on that screen will absolutely take your life. So that's another message we're trying to get across. So, what other ways can we lock up our weapons? You know, there are locks,

trigger locks, gun cases, lockboxes, biometric locks are so many other ways and during our events, give out gun safes. It's a non-profit we are giving them to the parents. And when you know, someone's always going to scream it's too expensive. Well, then we show that there are gun trigger locks, gun locks, there are other avenues, but when you look at your kids and you look at your children. Is Five dollars a lot to protect their life, and your neighbor? It's not, so there's really no excuse and we need to erase that ideology from our mentality. We do not believe this is an accident? If you look at the picture that is not an accident, whether he grabs it and hurts himself or shoots his mom or his brother. This is an incident. It's an incident caused by your irresponsibility, and carelessness, and if you look again, it's Mom and Dad's fault, and when we look at the kids that do make bad decisions, and they do bring weapons to the school or their friend's house. We need to look a step back and we need you to realize know why does this child have access to this weapon? That's where we need to start. So, if our program does look like it's for kids, but if you look carefully, you'll start to realize, it's not. It's for adults. We need Mom and Dad to go home with the understanding that their idea of securing a weapon is a threat to you me and to our kids.

You have the right to bear arms, you do. But with that right comes with a fear and obligation to secure them and that's what we want to teach in our program. Gun safety is a habit, but it like any other good habit we need to practice it and practice it and be reminded and reminded and that's the same thing we want to do with our program. The kids count on us to protect them, you know, we are their shield when in danger. I know the topic of gun is a high political topic, but us as Leaders we need to not shy away. When we shy away from it we are inviting danger, and we need not to because these kids really count on us to protect them. When your child finds your gun, disaster strikes. It's your fault and it's blunt and it's out there, but that's exactly the truth and we want mom and dad to know that. What you're seeing if you look closely in the back there is a meter parent gun safety meter. At our events you know, how kids at school were grading them on behavior, participation on everything on grades. This event is so super neat because the kids get to go up there and get to grade mom and dad right in front of everybody. Dad walks off the stage with a big letter F. Here thank God, the mom got a B she had talked to them she did store it. There are different criteria's but they graded her a B after this workshop she came to tell that she was going to be a mom from now on and the dads that got F's while it's funny and everybody was joking at the workshop before they left they made sure to come to Roman and tell us we're changing the way we live in my household with guns. It's a great tangible eye opener for both parents and kids alike in a fun environment. If you look here this was in 2016, in 2016 more children died from motor vehicle, crash accidents, and Firearms today, than the other way around, obviously the pandemic, social issues economics, the highest rates of suicide have increased from the ages of 7 from seventh grade to 12th grade in the last two years, obviously is the pandemic distress, the isolation, the worry. That's more reason we have to go after the kids and the parents and change their mentality, when it comes to gun and proper gun safety. At the end the kids are awarded. They are super cute. We ask Mom and Dad to frame them like it's a diploma from Harvard. Why? because we want mom and dad to remember what they were taught and we wanted the kids to remember what they were taught. Pride in gun safety education is a real step forward in preventing tragic incidents and saving lives. I know some school districts might shy away from it, but we need to get out there and scream and yell. This is what we're doing. We're going to just the way we have intervention, for the kids that are dyslexic that are slow readers. This is what we're doing and you have to scream on the top of a mountain that we're doing this for the kids and be proud of it. We can't shy away from it, no more because it's not going to go away. As a matter of fact, if we do the opposite, it's just going to get worse and that's why we're here today. We have a kid's slide that I want you guys to see, what you are going to see and I'm going to run through it really quick I know we are being timed. It what the kids actually see, the children never see what you all just saw its for adults. This is the one that we use during our events. Everyone, look at it so is this dangerous? When we're having a kid event it's so interactive. Everyone's yelling yes and no its the cutest thing and then I explained to him, what his calls can guide you from belly to neck in a second, it's extremely dangerous. So, why do I do that? Is because perception, we need their perception. They need to use their eyes to make better judgment calls? That's why. So, is this dangerous? Kids are going to say, no, but if you look really careful he has two real guns on his pants and a knife. Again, if you're law enforcement and you're seeing that you have to make a split decision. So, we want the parents to understand they as parents need to make better judgment calls when they're buying so called toys for their children. Some things are evident and clear is this dangerous? All the kids will yell? Yes. Everyone knows the answer. That, which is it. We asked again, use your eyes. Is this dangerous? Can anyone tell me why? If you look real carefully there is no m on those M&M's those are fake poisonous candies. They're not M&M's. The kids are like wow, when they look at the second time after I tell them they all see the light. They know it's not what it should be. Why are we asking if this is dangerous? We're asking if this is dangerous because society today movies, videos, social media, Facebook, Instagram all the stories are going to tell you what it is and in our events people actually do yell. Yes. So, we stand up there and remember our events have security and personnel and law enforcement and we tell them no you have been lied to, that is wrong. Children growing up need to have who to look up too, and they need to have a sense of protection of being provided for a being safe in a sense where they know they can run to these people. We need to reiterate the idea that law enforcement are there to protect and serve. That's why we bring this picture up to these kids. So, is this dangerous? All the kids start yelling? Yes. Yes, and then we asked them, whose fault is this? That's when you see the dads, the brothers and the uncles they get uncomfortable on their seats. The children themselves right next to Mom, and Dad, will yell Dad. It's dad's fault. And it's amazing, when you're in front and you're doing these workshops and you can physically see an epiphany. Someone just realized. Whoa. I've been making a mistake the way I live with my kids. Is this dangerous? Everyone giggles and laughs because we say yes, if a creepy old guy is making faces, right? I got to go all the kids, giggle and laugh. And you know, remember this is an interactive program with the children. Same thing with this, they told

me no and then I have to tell them regretfully it has a severe case of rabies, because we want their perceptions to change. Of course, the end goal is the perceptions on weapons. So again, in this dangerous. Yes, why whose fault is it, you know, whose fault is it? So, it is an adult program that's been described as a child's program because the adults at the end of the day, they're the breakers or not. They're the ones who are going to make the difference. They need to change the way to secure the firearm We are in the Rio Grande Valley and we show this, and I asked, if this is dangerous, they almost pop-up out their seats, they start screaming that they were chased, and they were this, and they take you forever, and it's just so exciting to get to giggle and laugh for a minute. Same thing with this one, remember in our event there's a lot of back and forth. That's why these pictures are repetitive but with kids, you need to do that they need to see it. You know, what is he thinking? And they tell me. Well, he definitely wants to touch it. Yes, he does. Yes, he does. Whose fault is it again? And there you go. You see them going like this because he knows it's his fault. This picture is the most important picture in the slide, is this dangerous? All the kids? Yell no, some will say, maybe the real answer is 100%. Yes, it is, because what really pulls the trigger to a gun? a lot of people think a finger but it's not what it's emotional, sadness, depression, anxiety, stress. Is Mom and Dad getting a divorce, is we're losing the house, is it my parents that just got fired. Someone lost a job or it could be a heartbreak, but when you're so young children are curious creatures by nature and two they are impulsive. We want mom and dad to know that that is very dangerous. They cannot no longer ignore their children's emotions. They need to really extend their hand, a hug, a prayer, something needs to be done they can just walk. Here in the Rio Grande Valley sadly we know, because we talked to so many parents. This is the method and the idea of most men of securing their firearm under their pillow. That is wrong and that is dangerous. So again, just like the other videos, were just trying to get that message out. Never Point anything to anybody in anger a weapon, a firearm, banana anything at all. Can you tell the difference which one's a toy same with the other one? The answer is, no. We need the parents to understand. They can't tell the difference. When the child sees it on your kitchen table. He can't tell the difference. And most importantly, when they are outside at the park and law enforcement walks by, they cannot tell the difference. Guns are not toys, so lock them up, who are we talking to, we're talking to Mom and Dad because sadly almost 100%, but the true numbers as we were in an actual Board Meeting 98% of all guns found at school came from an unsecured gun at home, so we are talking to Mom and Dad here. We visually show the parents there are regular gun safes, biometric safe, and all sorts of safe. If they can't afford that there are gun locks, trigger locks. There is other avenues they can go next. What is one thing that all the federal prisons and state prisons have in common. All the kids will yell at me while they're bad guys, and I said, no, the answer is they're adults. Adults do and can make mistakes, so if you see Dad that left the gun there you go tell Mom. If you see your big brother left the gun there, you go tell Dad, you tell someone something. Kids look at us and they think we can do no harm if we're doing it. It's okay. We're explaining to the kids no, you need to be your own superhero. You need to, if you ever see a gun, make sure to stop look, think and walk away. And most importantly, you tell an adult. That's what that little superhero image is for. Here's the guide meter that I was talking to I didn't realize it was there, but just to go from top to bottom green all firearms are locked and unloaded and property secured away, and not as accessible to Children firearms and Bullets are stored separate. That is an A. Dads who get an F are red. Weapons are kept on plain sight, weapons are accessible to children. Children are aware all hiding places. Guns and bullets are thrown together. Does anyone have a clue in this room? How many households live in the red? You will be surprised the actual number is over 60% go home and realize that many of those kids have access to weapons right now loaded and ready. How do we prevent gun incidents, child suicide and gun violence? Intervention, we need to really change mom and dad's idea of what gun safety is. So here is a case, way to go you value the life of your child and take every possible, precaution to protect him or her. Can you imagine walking out of a workshop with a big great big F? You have three kids and your son, just had to a big F report card. You failed. You're not doing your job as a parent. You're none action is a threat to the life of your loved ones. Your actions and efforts equals your Love towards your child. When dad and mom leave our workshops. they understand what's going on and it changes. That's who we are, real quick I wanted to just say a few more things. Gun violence is a devastating complex problem. That's no different than any other public health challenges that require and demand comprehensive joint solutions by society the government, but more importantly by our Educators in addition to massive violence. Thirty-six American lives are lost to gun suicide each year. It's a topic that needs to be focused on society needs to stand together in mission to make gun safety that everyone stands behind. The focus absolutely must shift from either supporting guns or not. The focus needs to shift to supporting children and their safety to making sure that there are a live. If the effort in the mission is to create a gun safe world within our own children than education is a must. So that's why Roman and I are here today. If you guys have any questions, please let me know. We are on Facebook, Instagram and we have our own Web page. We hope that everyone agreed a little bit or learned a little bit and I hope you're interested and if you are you can please reach out to Roman. And I anytime Romans started this, when he was 13 years old, out of fear, and that's me as a mother backed him up and when he came to me, when he was 13 years old. He said that when he would go to school and when I asked him, what are the school's telling you about it, but as your teacher saying, what is your principal? He said, nothing not a word. So, what do you mean nothing? Nothing? They brought in cops makes me more scared. So, out of the fear, this was Roman's goal, and we hope it does somehow bring a little bit of peace and a little bit of wisdom. So as your words say out there, we can change the world starting with Mission CISD. Thank you all very much.

Board Members responded Thank you.

Dr. Perez stated as a matter of fact we do have some dates and some sessions already scheduled.

Dr. Roberts stated we have a parent meeting scheduled next week on November the 17th and the 18th, and then we're starting with high schools. On November 30th we will have Mission Collegiate, Roosevelt Alternative, and Options and in December the 1st and 2nd will have the two High Schools will have them by grade levels and then we will be scheduling the Junior Highs.

Dr. Perez stated we will be sending the schedule to the Board. It is a nonprofit organization. The training, believe me, is inexpensive.

Mr. Juan Gonzalez asked if it was in person.

Dr. Perez responded it is in person and they take from 60 to 100, but they normally have done them out in the community. However, we want to do them in our schools our Parent Liaison Program is going to send invites to our parents. We will be sending them to the parents. The parent Liaisons will register them, so we can have the secure numbers and we will be having them at our schools. We didn't want to wait to do quotes and RFQ and all of that because, you know, you've given me and the staff the authority to be able to spend some money, and this is very, very inexpensive yet the results that are going to yield will be tremendous. We want to start with secondary schools. Now, moving forward in December we will probably bring something to the Board because we believe that it needs to be ongoing every single parent, every single child needs to be able to hear this message. We do have a threshold on expenditure. There is procurement regulations, that will need to be followed. However, in setting up four sessions, it's going to be very minimal. We can get started right now, without going through the other procurement process because we're not coming, close to any of the thresholds in Board Policy or State Procurement Regulations. Any comments from the board?

Ms. Minnie Rodgers asked have you contacted clubs in our community?

Dr. Perez asked you do have some sponsors, you mentioned?

Romans mom responded Yes, ma'am, we have different clubs that support us. Our biggest supporter is Mr. Alonzo Cantu from Lone Star Bank. That's why if you look at our events, Cowboy Cash is in all of them, Coyote Arms, Buffalo Wild Wings. I don't have the list of Insurance, many reputable companies that have gotten on board. The library always donates their facilities for free. Radisson has donated all their areas for free from a Green Beret. We have a big support system here, but it's nothing like when a School District gets behind you. How many children can you touch through a school district, it's massive.

Dr. Perez responded when I heard Roman and his mother come and talk to us. I mean, I got chills because it was like, this is what we've been looking for and I know the reason you're asking is that you were involved in many City Clubs.

Ms. Minnie Rodgers responded I belong to Mission Lions Club and we have a lot of older people who are crazy about their grandkids and this would be fantastic for them.

Dr. Perez responded we will be glad to provide the contact information.

Mr. Gonzalez responded it was a great idea.

Mrs. Petra Ramirez responded I don't have a question, but I do have a comment. I really like the simplicity of it. I think that it's very easy for parents to understand. I like that it's blunt and it's very easy to understand. It's friendly and the thought of you all bringing that they have to be in contact with the police and securities, because the way our world is going right now, we really need it. The kids need to learn that law enforcement is there for them.

Roman's mom responded Dr. Perez did let us know that we are going to be able to meet with Mission Security. Law Enforcement is in general, trained right away, you know, the position had on the Hip near the badge, shoulders back eyebrows down. We asked them that during the event we want them to be very social. We want to rebuild that relationship with students and Law Enforcement. At least for that moment in time, there are pictures, they are standing next to them. Once the officer makes himself approachable. You'd be amazed the kids go right next to them as if that is Superman and they lost that somehow. We are hoping even if it's a baby step to bring it back.

Mrs. Petra Ramirez asked do you do the presentation in Spanish too?

Roman's mom responded we were told that they wanted it done only in English for the students and in English and Spanish for the parents.

Mrs. Betty Mendoza made a comment I think it's a great idea. It's reality. I mean, we have to face it. That is going on every day here

in our community. I want to know how Roman interacts, especially with our high school students. I think it would make a big difference if we hear from you Roman, you seem to be a great guy and you could be a good example to our students going. Come down to their level and also, I'm hoping that our parents do get involved and that we don't humiliate them in any way or make them feel like they don't want to participate because they're going to get an F. I'm sure you know how to do that.

Roman's mom responded it's all volunteered. We don't force anyone it's all in a volunteer-type. Just real quick on Roman the reason why I do the speaking here in the workshops is that it is a non-profit and we go through an attorney and make sure that everything is done right. They explain to me Roman is six foot but he is only sixteen years old, so he is not even legal, so for that when we are in a formal setting they make sure that I do it, but Roman is very Hands-On he does all of it. I've had parents come to me totally changed. If our meetings could be longer and bigger with your power, then that would change so many and it really will be what it says outside. That's how you change the world you need to change perception and the kids, no matter what mistakes they do they're a product of their environment. We want to kind of take a step back and make sure Mom and Dad are getting the message. It really is a great big, huge thing. I know sometimes is political Hot Topic, we're a non-profit so that means that we can be for guns or against guns. We are just here for safety. The nonprofit is only three years old that in those three years he has done so much. We have never gotten close enough to schools this size before. Thank you all so much.

2. Workers Compensation Annual Review

Mr. Joel Garcia, Assistant Superintendent for Finance, introduced Chase Carlisle Insurance Workers Comp Solutions representative stated Workers Compensation Solutions was formed in 2001 as an Interlocal Agreement and as a Modified Self-funded Workers Compensation Program. It is an Interlocal Agreement, made up of school districts throughout the state of Texas. Workers Compensation Solutions in 2005 looking to make a long-term commitment to reduce their Workers Conversation cost into invest in to our employees. Through that partnership I'm here on behalf of Edwards Risk Management. We've been serving school districts for over 30 plus years specializing in workers compensation services. We do appreciate the opportunity to serve the Mission CISD.

As we all know, the last couple years have been challenging with, the pandemic with Workers Compensation Solutions, our mission remains the same and that's the face. The changes in the challenges together with efficiency to Mission CISD, and to protect and serve all the students, staff and community by providing Comprehensive Risk Management Services. I'm going to talk a little bit about those services this evening. How we deliver those services and then we'll talk a little bit about the why and the dollars that are associated with some of your workers comp expenditures.

Loss prevention is the key to reducing your long-term workers compensation cost. We believe by providing proactive Risk Management Services that we can better serve Mission CISD students and staff. It has been a little bit challenging over the last couple of years. We had to meet the COVID guidelines. Whether it be in Mission, Texas, or really throughout the State of Texas or the United States. We were able to really customize our training. We could no longer get in front of your staff on a routine basis. What we had to do is we had to develop short safety videos. Those are five, seven minutes safety videos talking about safety and awareness to your employees because that's the key. It's Education, it's having your employees, your students, and your staff thinking, and talking about working safely. We were able to accomplish that over the last two years, 2021-2022 has really brought in a new transition for us. We're able to meet Mission CISD guidelines and get it in front of your staff and provide face-to-face loss prevention training. I'm not aware of any other workers conversation pool in the State of Texas who is delivering face-to-face loss prevention. I think it's very simple when you get down to it. Would you rather be sitting behind a computer listening to training or engaging with somebody who's providing your education and awareness? We do that through a number of ways, we do that with incentives and we engage with the staff that we are meeting with. So, loss prevention is always the key to reducing your long-term cost. And we do that at least three sessions here. In fact, we were in Mission this week, delivering also services to your auxiliary staff. We're going to talk about some of the key components that fall under loss prevention. We've got some scheduled trainings coming up in February, we will be leading our third session there by that time. We've already delivered two sessions. And again, we'll be doing that in February. Here's a recent instance Mission CISD Technology, Safety Security, and Fixed Asset staff engaging with our loss prevention services and I believe this was just last month. We're doing everything we can to meet your COVID guidelines, but again get in front of your folks. When we start talking about the resources available to Workers Compensation Solutions, it goes beyond, just Loss Prevention Services. It's about recognizing your employees who are working safely and leading in the area of safety. We've got some programs in place. It's the safe employee recognition campaign, and I'll talk a little bit more detail about that here shortly. We also provide a personal protective equipment to everyone of your auxiliary employees. Many of you are familiar with that program. Providing slip resistant shoes and boots to every one of your auxiliary folks. We will tell you a little bit about the why behind that. It really gets down the frequency of planes, your slips, trips and falls are your number one frequency workers compensation claim. It's a great program, you're our jewelry folks you are able to walk away with the shoes and boots with no money. It's a service that we deliver through the program. We also provide supervisors safety support, for your supervisors, want to have a short talk. We can provide them scripts to discuss. Just be aware of their surroundings on Safety and Security. We talked a little bit about the on-demand videos that were providing. We will

spend a whole lot of time with that. You have additional resources with over 500 safety videos for your staff. Should they want the additional resources there. The Safe Employee Recognition Campaign is a bit unique. It's really a two-part campaign where we will recognize employees throughout the year. These are Mission CISD supervisors recognizing their employees and their departments. These employees are really the goal of the program is to promote safety. If you have an employee, who's working safely, using the right protocols in place, the supervisors can recognize their effort in that or if they're leaving their departments in the areas of safety, they get recognized. That's the first part of the program. We have an incentive prize that we give to those employees just as a small token of our appreciation. The second part of that program is what we call an honor roll program. This allows the supervisors at the second part of this campaign to really get in there and determine who is leading within their departments of safety. As a small token of appreciation by the District of Workers Compensation Solutions, we provide them an embroidered nice stitched jacket, you've got to see what we're doing there with that. It's a small token of my appreciation, but it goes a long way with those employees who are leading those departments. The slide on the slip-resisting distribution, we typically roll this out in October and September of every year. It's an annual program. We provided over 500 pairs of shoes and boots to Mission CISD folks. It's just a wonderful program. We have a shoe mobile that comes on-site to the district. They're fully stocked with shoes and boots and approximately 99% of your employees walk away with their spare shoes and boots that day. Just an excellent program addressing the frequency, but also giving back to those employees as well. Gives them some accountability to work safely and be saying think safe. We've heard a few of the Loss Prevention Services that we deliver through the program also delivered to you the Workers Compensation Solutions Program is a wellness program. I think we would all recognize it over the last two years. The stress that the pandemic has put on our students, our staff, and our communities, we realize, and understand through proactive risk management, that happier healthier, employees are more productive employees. They're on the job more, you have less absenteeism. It can actually roll into your health care cost and the experience that you're having from a healthcare standpoint. It is part of the services that are provided through the program. Again. We have two campaigns, one in the fall and one in the spring. This year's fall campaign was better together. This is just a three-week campaign for your employees, and it's available to every one of your Mission CISD employees it's about setting goals and having an accountability partner. I think, anytime we have some accountability, whether it be our spouses, our friends, or family, that typically you're going to be able to achieve your goals. This is just a small campaign that steps in the right direction of thinking about wellness. They received every person who participates in this Wellness campaign, both on the phone, the screen will get an incentive prize. So, they participate in the fall. They're going to get a small token, which could be a water bottle if you had your shirt. This is why we've used many different things over the years to do that. But every participant does receive a participation prize both in the fall and spring. The campaigns, we talked a little bit about that.

We also provide a Wellness Coordinator stipend for the district to facilitate these Wellness Campaigns, we found it to be most effective that employees within the district to deliver these campaigns. We are providing everything at their fingertips to roll these out to Mission CISD employees. We have random, Fitbit drawings, we supported the district through the Health Fair and Fun Run Giveaways. So, any time we have an opportunity to support the district we are doing that. In a goal to have Wellness within the district. I'll talk about the StayAlert School Safety Reporting Program. This program is near and dear to my heart. It's overseen by our department. The StayAlert Program was started in 2000. There's a way to help students, staff and community members report unsafety behaviors. It was really driven by at the time. We were seeing an increase in guns on campus. That was really the goal at the time. He has really morphed into something much larger, but still guns on campus is always out of a very important report that can be reported to the StayAlert Program. We get reports of bullying, suicide, threats, violence, drugs. I mean the gambling is wide there, but at the end of the day, it gives a resource to your students and staff to make these reports, but confidentially and or anonymous. You can send it in online, by phone, text or email 24/7. A few of the promotional materials that we provide the program, on an annual basis. Typically, we do a big promotional push to September to get some of these materials out to the district. This year we've got a scratch-off campaign where we're using gift cards to really incentivize some of those students to go to the website and to know what StayAlert is. One thing that I will mention about StayAlert that makes it unique. There are many different types of reporting programs out there and available to school districts to really public and private entities and all those mechanisms are run through an online platform. We have that same capability and your able to receive those reports, but what makes us a little bit unique on that. Is that we have what's considered an on-duty monitor. Monitoring those reports 24/7 365. So, how does that make it unique? If you found an online platform and somebody says I want to submit a report that there's going to be a gun on campus. You often don't think about the information. You really need to respond to those. What campus is that in Mission, Texas? Who is it? And so, when we get an urgent memo report, such as a gun on campus, are on duty, monitors are engaging with those who are submitting their reports. Where is it? What time was it? Who's involved with it? You can take the appropriate action to handle those reports. Without that information. You can't do anything with it, and so are on duty, monitors are monitoring that, and they hit at any point when we received an urgent level report, whether it be suicide, the big guns off campus or someone's life is being threaten. It's considered an urgent level report and we are picking up that phone and we're contacting District until we get in touch with somebody. We take it very seriously. We are very proud of the program. You got to take some good with the bad there. You're going to get some reports that are not necessarily valid reports. But, again you have to take some of the good with the bad there, at the end of the day, we believe it's making Mission CISD a safer place for your students.

Dr. Perez responded and we can attest to the fact that we do get the calls, it could be on a weekend during the week in the evening at

night, the middle of the night. Those individuals do contact someone in the district whether it's Mr. Castaneda, Ms. Cruz, Ms. Garcia, myself and those wellness checks are done, Mr. Castaneda will coordinate with local law enforcement. We do get the service and that is something that is very valuable to us. That is the reason, even on Friday that letter was sent to the parents. We put that website, the text, the phone number, and all of that, but there is utilization.

Mr. Juan Gonzalez asked what is percentage per week you would say?

Dr. Perez responded it is not a lot but it is being used.

Carlisle Insurance Workers Comp Solutions representative responded It is being utilized by the District. I will typically be saying this for the last, but I will tell you Sylvia Cruz and the Risk Management Department does an outstanding job in promoting the services that are offered through this program. That's one of those programs where it's about and I have to commend Dr. Perez as well because it's about the administrators getting involved and talking to it to your students and staff should know what is available to them and I will tell you that Mission does a great job of that.

Mr. Juan Gonzalez responded Thank you.

Carlisle Insurance Workers Comp Solutions representative stated I want to talk just briefly about the Loss. It's about long-term management of your worker's compensation cost. There is significant exposure and risk with workers' compensation claims. Workers' compensation is highly regulated by the Texas Department of Insurance. If an employee is injured on the job and needs lifetime medical benefits, that will be provided to that injured employee. So, there are significant dollars that can be associated with workers' compensation. I'm going to talk a little bit about the most recent loss experience. We will look at that. Look at some of the large losses, and then we'll look at the overall we are taking savings to the District. So, what you can see, here's the five-year losses history. The first thing that jumps out to me is stability, and that's what you want within your Workers Compensation Program. You don't want the peaks invalids, and we have had some circumstances specifically in 19-20 and 2021 with COVID. In this program, the district benefits by a reduction of claims, because essentially what you are doing is you're funding your worker's compensation claims and you're paying for your claims only. When you have a decrease in 2021 and you reduced it down to approximately \$167,000.00 and you look that what you were averaging over the last four years, you're saving anywhere in the ballpark of \$200,000.00 dollars that benefited Mission CISD by being in a self-funded program. In addition, all the frequency there, we did see the frequent drop in 19-20 you had claims and then 2021 you have 65 compared to an average of around 125 in the previous three years. We have talked about some of the exposure and the risk with the district. Here's a little bit of the detail of your large losses. You can see today, we've got two claims for Mission CISD at approximately \$200,000.00 dollars. We had one prior to 14-15 and then we had also won in 2015-2016. So, there can be some significant exposure there, by participating in the program. You're capping your losses at an aggregate attachment and will speak to some of those dollars here shortly. There's a little bit in terms of caused by an action. I talked a little bit about slips, trips, and falls being our number one frequency along with sprains and strains. When we talk frequency or claims, we're not providing shoes and boots, just because we want to provide shoes and boots. We're doing it to address frequency. This helps us reduce your overall slips trips and falls. It's all about return on investment. You are investing dollars into your employees to ride their slippers as to shoes and boots and it reduces long-term costs. There's a little bit about the cost savings provided through the claims of Administration provided by WCS. You can see since 2004-2005 almost 19,000 workers' compensation bills have been billed to the program on behalf of Mission. The total amount of those filled was almost 12 million dollars. You can see what's actually been paid at approximately three million six hundred seventy-three thousand. That's an approximate savings of 68%. Why is that important? Because if you have a Claims Administrator that is not taking the time and attention to detail to review every bill and invoice that comes into the office on behalf of the district, those dollars can be paid out by Mission CISD. We take it very seriously and from my claims Administration standpoint, we believe that the claims Administration is one of the top administrators in the State of Texas. You can see almost that savings of almost eight million dollars to the districts. At the end of the day, we want to preserve the Mission CISD fund balance and to be able to do that in a number of ways here. You can see through Mission CISD's positive claims experience you've been able to provide claims reductions of approximately 2.7 million dollars in reliabilities. We've returned over \$315,000.00 to Mission CISD and your self-funded savings are approximately \$650,000.00 Those are dollars that are actually being retained by Mission CISD. In addition, I talked a little bit about protection on behalf of the program. If your amount, of claims in any given year, exceeds a certain amount the losses are stopped the program pays for anything above and beyond that. Workers compensation Solutions has funded approximately \$517,000.00 of Mission CISD losses. Some of the Mission CISD savings approximately 4.4 million \$261,000.00 since 2005. Those are consumable dollars that the district would have paid in a guaranteed type of funding arrangement where you're paying in the annual contribution rather than Mission CISD clients. I would say through the investment of your proactive services on loss prevention through your advantage within your Finance team and the accounting of it that the district has been very successful in managing their long-term cost and we believe this is due to the partnership that we've had with the district and the proactive approach of the district is using at this point. I will open it up to you guys. If you have any questions, I will tell you and I will look every one of you in the eye that Mission CISD does an outstanding job in managing their Worker's Compensation Risk. I believe wholeheartedly

that your Administration the Board here tonight, you're being proactive in your services. There's no other program out there that's looking to invest the dollars within a return on your investment. So, you're paying a little bit more into your fixed cost, but it's at the benefit of your employees which at the end of the day we believe in reducing your long-term cost. Unless there are any questions that will conclude my report. Thank you for the opportunity to serve Mission CISD we truly believe it's a partnership and if there's any ever have any questions, we'd be happy to address those at any time. Thank you.

Mrs. Petra Ramirez responded I really liked the presentation.

Board Members responded Thank you.

3. Prime – Pharmacy Utilization Annual Review

4. Insurance Consultant Cost Savings Options

Mr. Joel Garcia introduced Valeria Ybarra and indicated she will be presenting on the Prime-Pharmacy Utilization Annual Review and Insurance Consultant Cost Savings Options.

Ms. Valeria Ybarra presented and stated good evening on the agenda today I'm going to do a BlueCross BlueShield Prime Review normally this would be done by Prime and you'll see that they did put this presentation together. If you have questions, I'll jot them down and do my best to answer them at the end of the presentation. The information in this review is comparing data from October 2019 through September 2020 to data ranging from October 2020 through September 2021, it provides information about how rates and claims were projected for the 2021 through 2022 claim year, which we're currently in. That begins on October 1st of this year. We are working backward again here just a little bit. Before I start I do want to say that the BlueCross BlueShield portion of this presentation is pretty lengthy. It's a lot of details so we have a lot of information to run through and I'm going to do my best to summarize it for you guys so we're not here all night. I have also provided all of you with copies of this presentation, so, take note if you have questions as we're going through it, at the end of the presentation, I'll give you guys some time to ask some questions, and then we'll move forward to review some alternative, Pharmacy current change options for your consideration. First, we'll go over some COVID-19 vaccinations stats. This slide provides Intel about who is getting vaccinated and how much is the cost of the plan. When a member goes and gets their first vaccine a claim is submitted when they receive their second and even their third vaccine, another claim is submitted. So, essentially each time a member receives a shot the claims are paid through the plan. That's when we paid a total of about \$27,000.00 for the first vaccine and then you'll see it listed out there as about \$30,000.00 for the second and then \$614.00 for the third. One thing you can take away from this slide is the simple fact that 845 members are partially vaccinated, so you can expect future claims impact for the second dose and of course for the third dose as well. I do want to mention so you can take note that this may not necessarily be a fair representation of members that have received their vaccines in general. So, this only gives details about those members that have received their vaccinations at pharmacies or doctor's offices and it's been run through the Medical Board Pharmacy Plan. Vaccinations can be run under the medical plan. This slide is just information about members that received their vaccinations at a doctor's office or a hospital setting as I previously mentioned, of course, they can be run through medical or pharmacy plans, a very small portion of your population, received the vaccine that was rendered through the medical point, and then this just breaks it down for you. The top of it breaks it down on how many are partially or fully and then additional dose vaccinated and under the medical plan. The middle portion shows the vaccines that were administered and how many and then at the bottom it breaks down the information of what they were actually vaccinated. This slide goes over vaccinations under the pharmacy plans very detailed information for you guys to look at, again at the very top you are going to see how many were actually vaccinated under the pharmacy plan. It occurred quite a bit more just as it is broken down at the top. You will see again, vaccines administered. It's broken down the numbers there and then at the bottom, the vaccines administered, it's broken down where they are actually getting it done. This slide is a brief overview of where Mission stood at the time of the renewal of BlueCross Blue Shield, estimated an overall drug trend of 8.4%, I will review how the trend is derived in a couple of slides. But what you'll take note of is that drug Trend usage and utilization from October 2020 through October 2021 compared to 2019 increased by about April 8.4%. The year before 2019 through 2020 looking back Mission CISD did make a few changes to the pharmacy plan. That resulted in significant savings totaling a cost avoidance of \$491,000.00. Some of the things that were downers a switch in drug list, switch in pharmacy network and then that also increased utilization management and we implemented some Pharmacy limits and now are utilizing. That's how that cost avoidance was actually saved. In addition, you will see at the bottom from October 2020 through September 2021 the credit that was applied to the administrative fee for rebates totaled about 1.1 million dollars in additional savings to the district. That is a guaranteed saving to your business cost, that is a great point for savings. Keep that in mind I am going to refer to that savings and rebate structure a little bit later on whatever I give my presentation. This information goes over the components of trends, so again how I said that there was an increase of 8.4% in trend, it breaks it down on how Prime got to that number. This is a very busy slide, but just kind of take a look at it. You'll see and you can compare specialty to traditional and then the Benchmark. That Benchmark number is BlueCross BlueShield's price estimation. We are going to get into a little bit of information about overall pharmacy spend. This slide provides some eligibility data at the top and it breaks down costs a number and then, of course, you will see some generic drug utilization data at the very bottom.

One thing I'd like to point out is at the very top you'll see that the average membership decreased by about 3.2% while average utilizers increased very slightly by 1.8%. There are more pharmacy utilization numbers, that are going to have an impact on the plan paid per member per month, which increase by 9.4%. The top figure on the right-hand side of the screen illustrates this information on the bottom, it breaks down, the total cost per member per month by specialty and traditional medications. At the bottom, you'll see 93.18 total per member per month and of that \$18.54 per member per month is being allocated towards specialty medications, then, of course, there are more traditional medications. A very smaller percentage of 4.8% for specialty medications. This slide provides intel about the top conditions that medications are being filled or treating and then it also compares to previous your spent. One of the most alarming numbers is that diabetes accounts for about 33% of total pharmacy spend. The most important information here is what the plan paid per claim. The second to the last column is going to help you to identify the information on which drugs are going to cost a little bit more than what you spent. Whenever we are talking about traditional medications that are actually used to treat General Health and chronic conditions. That's really how Prime is going to classify the type of medications that your employees are taking and then there's also going to be specialty medications. Specialty medications are generally used to treat more complex and rare conditions such as cancer rheumatoid arthritis, and things of that nature. The way they have this presentation design is first we went through all of it together, the traditional and specialty. I am going to go through the traditional medications which are where the bulk of your spending is. Then last, we'll go over those specialty medications, typically a little bit higher in cost but there is less utilization there.

Mr. Roy Vela asked on slide number 8 what does other than none categories mean? What types of medicines are those? Just wondering if they are in the top 10.

Ms. Valeria Ybarra responded I'm not sure. I would have to look into that and ask Prime which medications are classified there. Unfortunately, Prime wasn't able to be here, they'll be able to answer those types of questions. I can look into that data for you. Here is some information about more of the traditional performance key metrics. Again, at the top, you are going to see the eligibility. We go over average members versus average utilizers, and you'll see that there are 3.2% fewer numbers versus 1.9% more utilization. That's going to impact the cost per member per month. Cost is broken down as the most important that you want to take away from there. That's what the plan paid per member per month. The total cost at the top is going to pretty much give you the figure which includes the member's responsibility of the copay whatever they are paying out of pocket and then down at the very bottom is the utilization. We are going to see how things are being filled that are considered traditional medications. The figure on the right-hand side of the screen again, kind of breaks down, which medications are being filled for certain conditions, but the most important information again from this slide is going to be traditional drugs represent 99.7% of all claims and they account for 81.2% of total drug costs. That's where the majority of your drug cost is being spent that are traditional medications, which is a positive thing. The last slide breaks down top specialty drugs by plan A, so you'll go ahead and take a look at this slide and review those medications that were being filled and how much they cost. One thing I want to point out it looks like the second most expensive drug. There have been two claims that total \$57,000.00 each this appears to be a medication. Just something to put on your radar to take a look at you can do some research on that specific medication.

Mr. Roy Vela asked if this was a tier 3 or 4?

Ms. Valeria Ybarra responded I would assume since its extremely high cost.

Dr. Perez asked what is it for?

Ms. Valeria Ybarra responded it is multiple sclerosis. This concludes the Prime overview.

Ms. Valeria Ybarra stated as I previously mentioned, that we are going to go through a possible recommendation to make some changes. Open enrollment or your plan renewed on October 1, 2021, we are a little bit past. We can make some major changes to the plan where you're going to see a little bit more of an impact on that claim spent. The best thing that we can do, is a few changes behind the scenes, such as a policy change in the formulary. This first slide that you're going to see here goes over the different formularies that are available for Mission Consolidated Independent School District. Mission started off on the basic drug list. This is an open drug list with very few limitations. It results in very low generic drug utilization. Of course, everybody knows generic drugs cost a little bit less. In 2019, you guys switched to the balance drug list, the balance drug list, and introduced some Tyler Management on preferred drugs. So of course, that's going to be a big extreme spend on some of those more expensive drugs. The two options were going to run through today, are the performance select drug list and also the performance drug list. Those are the last two based on the illustration on this slide, you'll notice that more restrictions are put in place on the formulary. The more savings that the district is going to realize, so just keep that in mind this is a very useful illustration just so you can see visually. Where you guys started the direction that we're going. Currently, Mission is on the balance drug list. It has been in place since October 2020 with the specific prescription drug lists. The district was to use a rebate credit in the amount of \$47.84 per employee per month with the snapshot most recent of an average of 2,052 employees. That has saved the district just based on 12 months about \$1.1 billion and that's just on rebate credit alone. The first option

that you guys have is the performance drug list. You will see that the estimated savings for prescriptions are \$322,383.69 I did include a couple of extra information in the folder that breaks down this information in detail, but you'll see that 51 members are impacted. There are 22 drugs that are apparently being filled up and completely removed from the PDL and in the information, I provided to you, you'll see those exact prescriptions that would be impacted. There would be one drug tier change and then one drug alternative that would be pushed to over-the-counter medication. Fifty-One members for a group of your size is a very minimal disruption which will see significant savings that you can realize. However, this PDL change, it reduces the rebate value that is currently being applied to the administrative fee. My fear, if you guys were to switch to this one, would be a lot of saving at a fixed cost after reviewing this information with prime. I asked what would be the maximum reduction in that admin fee credit that you're receiving a rebate and they said that it could be up to \$10.00 with it being up to \$10.00. It's a loss of \$245,000.00 estimated. That \$322,383.69 in estimated savings is reduced down to about \$77,000.00. So, we'll look forward to going over another option that I think might be a viable option for you guys is out of the performance select drug list. There is an estimated savings of \$205,793.22 of course this one is a little bit more attractive. There's a lower member level impact, only twenty-three members would be impacted. You'll see the list of those drugs. Sixteen drugs that are currently being filled with just be complete of the PDL.

Dr. Perez asked so then those twenty-three members, what would they get?

Ms. Valeria Ybarra responded that comes later in my presentation and we will talk about that.

Ms. Valeria Ybarra stated with option number two you guys will continue to maintain that rebate credit. Of course, my recommendation, as you see here is to switch to the formulary, which is the second one that we reviewed on this formulary you are going to continue to receive the highest rebate value. You're going to continue the savings on the fixed cost. There's at least amount of member-level destruction. And then, of course, prior to the October 20, 2022, renewal, we can use some alternative options because I think by then Prime will have some alternative options for you. Then the last part that I did want to go through is just kind of setting some expectations if you guys want to make these changes, the effective date would actually be February 1, 2022. We do need to submit these changes by December 1st of this year and the reason for that is because you would Blue Cross Blue Shield does need to send out a notification to impacted members sixty days in advance, the information that they're going to send out to these are the prescription medications have fallen off the PDL is going to be education and it's going to give them some information about what their alternative options are. So just because a member loses access to certain medication that they're taking this not necessarily mean that they are alternative drugs available for them.

Mr. Roy Vela commented I have a quick question I know this is going to be and I was going through the list of the medicines and I don't know what those medicines are for the most part, but I have a question. I know that the option is going to go to generic if those drugs are not available because those are named brand probable tier three or tier four. So, if the generic doesn't work for the patient and say the doctor prescribed and is asking for a name brand, which is taken away. Can they ever get it back?

Ms. Valeria Ybarra responded I mean, there's going to be ways that a member can get prescription medications thru step therapy. Just because they're going to be stirred to you a generic medication doesn't necessarily mean that there's not another name brand medication that would treat the same condition on the same formulary it's just the specific drugs that would process and be identify that they're going to be removed because of the cost of it. There are other alternatives, whether they're generic or tier 3, or tier 4.

Mr. Vela responded Thank you.

Ms. Sylvia Cruz Director for Payroll, Employee Benefits & Risk Management, stated I just want to get the direction from the Board to remove the Performance Select so we can contact Prime.

Dr. Perez commented this does not require Board voting or anything like that, just a recommendation. Mr. Hansen, please correct me if I am wrong the Board did them as our consultant. So tonight, it is not on the list to vote. However, you know, they've been working with Mrs. Cruz, Mr. Garcia, Ms. Lorena Garcia, and with us and that is the recommendation of our consultant.

Mr. Hansen responded if the Board wanted to vote on something, it could vote with this subject on the agenda.

Dr. Perez responded even though it only states presentations to the board.

Mr. Hansen responded yes because it is informational. It just needs to be a subject on the agenda in order for the Board to be able to take a vote on this, if the Board desired to do that or if they are concerned about the recommendation the Board can certainly hold a whole act on the response.

Dr. Perez responded okay, thank you.

A motion was made by Mr. Roy Vela for approval to approve the recommendation from the Administration recommendation.

Motion second by Mr. Juan Gonzalez to accept that motion. Motion passed unanimously. Vote 7-0

5. Hanna Hurricane Update

Mr. Chase Carlisle presented and stated Administration asked me to be here tonight again to give you an update on where we stand today, on the Hurricane Hanna claim that we suffer in July 2020 I put up these slides for your they should look very familiar to what we have seen in the past. A simple update on where we are today. There have been some payments that have been processed towards the district for repairs. As I explained on day one when we first did an update of where we stood this takes time and I understand people want stuff they want money they want our building. So, they can have our student facility again. But again, like I explained from the beginning and did the long-drawn prices that do take some time, especially when you're in public in any environment, or we have to go outbids etcetera. Real briefly where are we right now? We are still working with the Administration on collecting the invoices for these repairs our team along with Ms. Garcia, Mr. Garcia, and Mrs. Cruz did have a meeting last week to get a list from the adjuster of what we still lacked to get this closed out. It's a simple timeline of where we are right now. The main one that I wanted to share here is what we heard of the statement of laws and these are the financial numbers that we have looked at in the past. As we sit here today we're showing approximately \$585,000.00 district damage from Hurricane Hanna. We do have a Named Storm Deductible for that storm, which was a \$100,000.00 that is deducted from the \$585,000.00 along with about a \$110,000.00 of what we refer to as the recoverable depreciation as I've explained in the past the way the property insurance policy works, it is written on replacement cost basis meaning that they were going to replace what was there at the time of the loss. However, the policy does not pay the replacement cause unless we can actually replace it. What you'll see here are the ending payments, which gross payment that the district has received is approximately \$276,000.00, a \$110,000.00 is being withheld by the insurance carrier until we make these repairs. And so that is where we are today in the process of collecting the invoices, collecting the repair receipts then they're verifying that the work was done so that we can then go to the carrier and ask for that Recoverable Depreciation of \$110,000.00. have been some additional things that have come up along the process that this team is aware of. I think a couple of those are the public gym floors, the team has looked at those Mr. Garcia has been very diligent about running the invoices, and the estimates, for those repairs. Going forward again a simple thing it's as simple as the process of repairing, the facilities. I believe that is going on. I believe the field house is scheduled to start on Thanksgiving around that holiday. So again, until the facilitator of the repair and we can show evidence of that. We will be basically be sitting back and waiting for that so we can issue the check. Any questions?

Board Members responded no, thank you.

VII. Discussion and Possible Action

1. Discussion and Approval Annual Comprehensive Financial Report for the Year Ended June 30, 2021

Ms. Lorena Garcia, Deputy Superintendent for Support Services, stated I just wanted to share with you all, that this is the first for Mission CISD which is the Comprehensive Financial Report. The district has never prepared a Comprehensive Annual Financial Report. It's about 185 pages and it's a combination of a lot of work from a lot of our Internal Staff as well as our External Auditors. I just want to recognize Mr. Joel Garcia our Assistant Superintendent for Finance as well as his team. He's been working with Ms. Becky Magee our Internal Auditor and as well as our Director for Finance, Ms. Anna Zuniga, and then also Ms. Sylvia Cruz Director for Payroll, Employee Benefits & Risk Management as well as her team. They have also received support from Jorge Cavazos and Information Systems. We also have some schedules on the fixed assets that our operations team Mr. Rivera and Ms. Ana Vely Uresti with fixed assets provided. A lot of hard work has gone into that. It's 185 pages, what this is it. It provides a lot of transparency to our community. We will be applying for an Award Program from the Government Finance Officers Association. There's an Award for Excellence in Financial Reporting and this book was modeled after that program. As soon as this is completed and approved we will be submitting it for consideration. I'll let our External Auditors provide the report.

Ms. Esmeralda Yniguez partner with Carr Riggs & Ingram presented and stated tonight we will quickly go over the results of the audit. We will go over the Auditor's Reports, Financial Statement Highlights, Federal Awards Highlights, Communications with Governance and we will discuss the upcoming standards. On the financial statements, the statements subject to audit include the Governmental Activities Government-wide statements, your Major Fund, which includes your General Fund, and the Aggregate Remaining Funds. Our opinion of those statements is an unmodified opinion, which is the best opinion available. The Financial Statements are presented fairly in accordance with accounting principles generally accepted in the United States of America. There were no auditor areas where an opinion could not be rendered. We do have an Emphasis of Matter paragraph in that report, where there was a prior period adjustment of \$460,000.00, but that is related to the district's implementation of GASB Statement No. 84 Fiduciary Activities and in order to

present the Custodial Funds of the prior period Statement they were required to record that prior period adjustment. The other section is on the Federal Awards is a Single Audit. That involves two reports that are issued. The first one is our report Internal Control Over Financial Reporting and on Compliance and Other Matters based on an Audited of Financial Statement performed in Accordance with Government Auditing Standards our opinion on that one is also unmodified and no findings were noted. The second report is on Compliance for Each Major Program and on Internal Control over Compliance required by the Uniform Guidance. Audited requirements that could have a direct and material effect on each Major Federal Program and the Major Programs that were tested this year were the Child Nutrition Cluster, Special Education Cluster, COVID-19 Coronavirus Relief Fund, COVID-19 Education Stabilization Fund. Our opinion on that report was also unmodified with no findings noted. On the Annual Comprehensive Financial Report, if you recall last year the report was half the size which you have today. Some of the difference from last year's report to this year's report is that you have different sections, you have a letter of transmittal, and also more combining Fund Statements. So, the first thing that we're going to talk about is the Statement of Net Position. The Statement of Net Position includes the Governmental Activities. We put the last three years so you can see the Assets and Deferred Outflows of Resources have been going down from \$350,000,000.00 in 2019 to \$342,000,000.00 in 2021. The Liabilities and Deferred Inflows of Resources went down also. The Net Position Governmental Activities is down a little bit, but this is a Governmental Activity. Some of the reasons why assets went down are just because of your pension and open balances over the years. TRS is having a tracking report and based on that your balances have been going down the same for the Liabilities that is what basically is affecting your Liabilities and Deferred Inflows is the changing on the slight decrease due to refunding bond and decrease in pension and OPEB liabilities and deferred inflows balances. The Net Position is also affected because of the pension and the open balances. Next, we will talk about the General Fund which is one of the most important things that you would like to see. This one is the revenues and expenditures in your general fund only and this has the last three years. So, you can see that the general fund's revenues in 2019, were about \$160,000,000.00 this year. This year it was \$171,000,000.00. One of the biggest reasons was the state revenues went up, because of the new programs that the State was giving away. General Fund expenditures went up also this year, possibly expenditures that went up to were mainly because of new supplies, a new type of instruction needed because of the situation that was happening this year. Next, this is the budget for the current year in the General Fund. You can see that revenues, the budget amount for revenues this year was \$174,000,000.00. The district got a little bit low than what was budgeted, but I mention before it was more than last year. It was just a little bit below what was budgeted. in the expenses, the same way you were budgeting \$182,000,000.00 and, in the end, the only thing that was a spent \$165,000,000.00. As I mentioned before current your revenues totaled \$171,000,000.00 and that's an increase from last year, mainly because of the State Revenues. Expenditures for this year were \$165,000,000.00 and again the main increase was because of the instruction Facilities, Maintenance, and Operations. If you want to see the results of the current year if you take the current year revenues of \$171,000,000.00 and current year expenditures of \$165,000,000.00 million, the total net change, this year after a transfer that was made to a health insurance plan was about 4.5 million. So, basically, that's an increase in your fund balance. Your fund balance at the end of the year as of June 30, 2021, was almost 81 million. At the end of the year, you ended up with your fund balance of \$80,898,169.00 out of that fund balance \$71,000,000.00 is unassigned the rest which is about \$9,000,000.00 is a fund balance that is restricted for a long-term death and commodities. The rest is \$71,000,000.00 which is a very healthy fund balance for a school district.

Dr. Perez asked so basically, it would have been 5 million saved but because we transferred 1 million last month to the health insurance. That's why it's down to 4 million.

Ms. Esmeralda Yniguez responded yes 4.5 million. Again, this balance we were talking about in 2021, but you can see assets have been going up from the previous three years. The most important thing from 2019 your fund balance was \$69,000,000.00 and now you are \$80,898,169.00.

Dr. Perez responded you should have looked at 2018. 2018 is was about \$62,000,000.00. So, as you can see from 2018, it's been going up and up and a lot of it was because the Board approved the TASB study and we did a lot of attrition by savings So that we would be able to put some of that money into the salaries to maintain and keep up with market value. That's the intent of those savings. Thank you.

Ms. Esmeralda Yniguez continued by saying I did want, to mention on the Federal Awards Highlights you had total expenditures of Federal Awards of \$32,708,336.00 again of that we tested four major programs the Child Nutrition Cluster with \$13,580,787.00 Special Education Cluster with \$2,308,109.00, Coronavirus Relief Fund with \$1,602,379.00 and the Education Stabilization fund \$2,759,816.00. We have our unmodified opinion on these reports with no findings noted. With Communication with Governance we just wanted to mention that on the part of the communication packet that you received you will just find information about Auditor Responsibility, Management's Responsibilities, Judgements, and Sensitive Estimates, Summary of Audit Adjustments, and Management Communication Letter. In addition, we also mentioned with the District Management and Dr. Perez as well and we went over, we did not have corrected adjustments we didn't have any audit adjustments that were corrected. We did have a potential corrective adjustment that was discussed with Management. We also went over a few observations that again we don't really have any significant efficiencies to report, but we did make some recommendations. Lastly, upcoming pronouncements we also discuss these in

detail with them, things to keep in mind, for next year actually this year. GASB Statement 87 under this Statement, a lessee is required to recognize a lease liability and an intangible right to use a leased asset. And for the following year, it is a similar statement that is coming up, but it is related to software subscription-based Information Technology Arrangements. That concludes our presentation, if there are any questions.

Board Members and Dr. Perez responded no, Thank you.

Dr. Perez stated again I want to thank the Board and Administration for working so diligently and within the last three years, we were able to add \$17,969,000.00 to the fund balance, so Thank you

Mrs. Petra Ramirez stated Thank you, in spite of all of this year. I think you've all have done an amazing job in Administration in working so hard from the very top great job.

Mr. Juan Gonzalez stated to be fair, I'd like to point out also that we had a 10% increase in revenue from 2017 to today for about 20 million.

Dr. Perez responded yes because a lot was in technology because you will remember that we were not a one-to-one school district. We went after a lot of grants and we wrote a lot of Grants. If not, that money would have come out of the fund balance. So yes, we've added \$17,969,000.00. Yes, that is true that the State provided some more funding, but because we were able to switch funding from local to grants and to federal and so forth. It took a lot of maneuvering and then us bringing several plans to you all and saying, well, we're going to have to buy the technology from local and you all approved it. And then once we got the grant monies, we would come back to you and say guess what? Now we have monies. So, we're going to switch funding. And you kept supporting those efforts. So, this is the result of everybody working together for the betterment of the District. Because now, we're at that point, also when the pandemic hit, we did not have to let go of our employees. Whether we had bus routes, whether we didn't have children on the campuses. As a matter of fact, this building was constructed and remodeled by our Transportation Department, by our Custodians because we were able to pay them salaries and we didn't let them go as others did. So, a lot of it was because we were very tight with our monies and it's not about wants, but needs. We still have needs that we're going to be bringing to you all. Again, Thank you so much.

The administration recommended Approval Annual Comprehensive Financial Report for the Year Ended June 30, 2021

A motion was made by Mr. Juan Gonzalez for approval. Motion second by Mrs. Petra Ramirez. Motion passed unanimously.
Vote 7-0

2. Tom Landry Stadium Construction Dispute

Mr. Ricardo Rivera, Assistant Superintendent for Operations stated the first item I have is the Tom Landry Stadium Construction Dispute.

Mr. David Hansen responded we will talk about it in a closed session.

3. Consideration and Approval of Allowance Expenditure Authorization (AEA) #01 for Structural Repairs on Varies Piers for the Tom Landry Stadium Repairs – Ricardo Hinojosa Structural Engineering

Mr. Ricardo Rivera stated Mr. Albert Trevino is representing Ricardo Hinojosa Structural Engineering who are the designed professionals for the project. Mr. Trevino is here is answer any questions. Mr. Rivera stated he would read the Agenda Item for the project. Consideration and Approval of Allowance Expenditure Authorization (AEA) #01 for Structural Repairs on Varies Piers for the Tom Landry Stadium this Agenda Item was presented and discussed at last week's Board of Trustees Workshop on Wednesday, November 10, 2021. Administration presents Consideration and Approval of Allowance Expenditure Authorization (AEA) #01 for Structural Repairs on Varies Piers for the Tom Landry Stadium. If you have any questions, Mr. Trevino can answer you.

Mrs. Betty Mendoza answered I think we did ask him plenty of questions last week and we got our answers.

A motion was made by Mrs. Petra Ramirez for approval. Motion second by Mr. Roy Vela. Motion passed unanimously.
Vote 7-0

4. Consideration and Approval of Change Order #1 for Forty-four (44) Delay Days due to Structural Repairs on Various Piers for the Tom Landry Stadium project

The next Agenda Item was presented and discussed at last week’s Board of Trustees Workshop on Wednesday, November 3, 2021. Administration presents Consideration and Approval of Change Order #1 for Forty-four (44) Delay Days due to Structural Repairs. If you have any questions, Mr. Trevino can answer.

A motion was made by Mrs. Betty Mendoza for approval. Motion second by Mrs. Petra Ramirez. Motion passed unanimously. Vote 7-0

5. Consideration and Approval of Construction Change Directive #1 & #2 for “Credit” on Hardware Handle and for Aluminum Frame Support for the Security Vestibules Project at Alton Memorial Jr. High, K. White Jr. High, Pearson Elementary & Roosevelt Alternative – EGV Architects

The next Agenda Item was presented and discussed at last week’s Board of Trustees Workshop on Wednesday, November 3, 2021. If you have any questions, Mr. Vela is here to answer. Administration presents Consideration and Approval of Construction Change Directive #1 & #2 for “Credit” on Hardware Handle and for Aluminum Frame Support for the Security Vestibules Project at Alton Memorial Jr. High, K. White Jr. High, Pearson Elementary & Roosevelt Alternative. If you have any questions, Mr. Trevino can answer.

A motion was made by Mrs. Betty Mendoza for approval. Motion second by Mr. Roy Vela. Motion passed unanimously. Vote 7-0

6. Consideration and Approval of Best and Final Offer (BAFO) and to Enter Into Contract with all Firms for General Construction Services – Job Order Contracting Status

The next Agenda Item was Consideration and Approval for Best and Final Offer (BAFO) and to Enter Into Contract with all Firms for General Construction Services – Job Order Contracting Status. This Agenda Item was presented and discussed at last week’s Board of Trustees Workshop on Wednesday, November 3, 2021. Administration presents Consideration and Approval of the Best and Final Offer (BAFO) and to Enter Into Contract with all Firms for General Construction Services – Job Order Contracting Status.

A motion was made by Mr. Juan Gonzalez for approval. Motion second by Mr. Roy Vela. Motion passed unanimously. Vote 7-0

7. Discussion and Approval of Resolution for the Casting Votes of the Hidalgo County Appraisal Board of Directors for 2022 – 2023

Dr. Perez stated the next Agenda Item is Discussion and Approval of Resolution for the Casting Votes of the Hidalgo County Appraisal Board of Directors for 2022 – 2023. You were provided a handout. As a school District, you as a Board are authorized to provide 155 votes and you can break them up any way you all would like to the following. As a Board, you have to come to a consensus as to how many votes you would like to distribute. I do have the resolution to read. You are to discuss and decide how many votes the Board will be provided to each individual as a corporate body and it should equal up to 155 votes.

President Jerry Zamora stated I have a motion to give 155 votes to Mr. Amador Requenez. Do you have any questions?

A motion was made by Ms. Minnie Rodgers for approval. Motion second by Mrs. Petra Ramirez. Motion passed unanimously. Vote 7-0.

Dr. Perez stated ok, 155 and this is what the Resolution states. Resolution casting Mission CISD votes for the position of Director of the 2022-2023 Hidalgo County Appraisal Board whereas the Chief Appraiser of Hidalgo County Appraisal District has called for the election of the Hidalgo County Appraisal District Board of Directors and whereas Mission Consolidated Independent School District is entitled to cast a total of 155 votes.

A motion was made by Mr. Juan Gonzalez for approval of the 155 votes. Motion second by Mrs. Iris Iglesias.

Motion passed unanimously. Vote 7-0.

Dr. Perez continued with as for ballots must be returned by December 15th, which is the deadline for accepting votes. Now, therefore be resolved by Mission Consolidated Independent School District, does hereby cast all allotted votes for Mr. Amador Requenez, Hidalgo County Appraisal Board of Directors for 2022-2023 read, passed, and approved at a regular meeting by the Board of Trustees for Mission Consolidated Independent School District on this the 10th day of November 2021.

8. Discussion and Approval of Bids, Proposals and Purchases of \$50,000 and Over

a. Award Purchase Fuel and Oil #750-22-0

Mr. Joel Garcia stated the next item is the Award Purchase of Fuel and Oil the intent of this contract is to provide a method to procure Fuel and Oil to meet the needs of the District. The District solicited Requests for Proposals in compliance with TEC Sec 44.031(a) requiring an approved method of procurement for expenditures of similar categories valued at an annual aggregate of \$50,000 or greater. We received four responses and we were able to proceed and award the four members. If you look at the second page of your package, you'll see that the vendors that are on the tabulation include Pico Propane and Fuels, Petroleum Traders Corporation, Oil Patch Fuel and Supply, and Arguingdegui Oil Co. Administration recommends awarding the contract to the Vendors listed on the tabulation.

A motion was made by Mr. Juan Gonzalez for approval. Motion second by Mrs. Betty Mendoza. Motion passed unanimously. Vote 7-0

VIII. Recommendation(s)

1. Approval of the Selection for:

- a. ESSER II, Bryan Elementary School Counselor**
- b. Licensed Specialist in School Psychology**
- c. Mission Jr. High Counselor**

Dr. Perez stated recommendations will be discussed in Executive Session and brought back in the open session.

IX. Items to Consider: The Board will consider and may act on the following items under a CONSENT AGENDA. Any Trustee may request the removal of an item from the CONSENT AGENDA for individual consideration and action.

Dr. Perez stated Consent Agenda includes from #1 through #9, if the Board would like to pull any item please let us know.

Mr. Roy Vela responded Dr. Perez I would like to pull item Item #7f.

Dr. Perez responded ok, now we have items #1 through #7e, #8, and #9.

Motion made by Mrs. Minnie Rodgers that the Board approves the Consent Agenda IX Item #1 through 7e, #8, and #9, excluding 7f. Motion second by Mr. Juan Gonzalez. Motion passed unanimously. Vote 7-0

- 1. Approval of Campus and District Improvement Plans**
- 2. Approval to Accept Schematic Design for the Child Nutrition Program CNP Freezer Project – DBR Engineering**
- 3. Approval to Accept Substantial Completion for the Security Vestibules Project at Alton Memorial Jr. High, K. White Jr. High, Pearson Elementary & Roosevelt Alternative - EGV Architects**
- 4. Approval to Accept Substantial and Final Completion and Final Payment, for the Mims Marquee Project – Javier Hinojosa Engineering**
- 5. Approval of Amended Resolution stating Annual Review of Investment Policy and Investment Strategies CDA (LOCAL)**
- 6. Approval of Budget Amendment for the Month of November 2021**
- 7. Approval of Bids, Proposals and Purchases of \$50,000 and Over**

- a. Award Purchase Professional Development Supplemental #230-22-0
 - b. Award Purchase Smart Boards K-White #341-22-1
 - c. Award Purchase Kitchen Equipment #803-22-0
 - d. Award Purchase Cook Chill Kettle Mixer #804-22-0
 - e. Renew of Tyler Software Maintenance
8. Approval of Donations
9. Approval of 2021 Tax Roll

7f. Renew Contract with The Center for Primary Care and Wellness (PCW)

Dr. Perez stated the next item is the approval to Renew the Contract with The Center for Primary Care and Wellness. At the December 18, 2019, Regular Board of Trustees meeting, the Board approved the contract with the Center for Primary Care and Wellness for a three-year term. There was a typo. It was understood that the agreement actually was for three years. With this agreement, it allows the staff and Provides them with guaranteed same-day appointments, minimum waiting time, flexible hours, Fee on-site employee health and wellness outreach services in coordination with the District's Wellness Program, Treatment of work-related injuries or illnesses as part of a worker's compensation network of providers for the District's Self-Funded Workers' Compensation Plan and Compliance with the District's pharmacy formulary pharmacy drug list to ensure employees are prescribed both cost-effective and formulary medications. Administration does recommend renewing the contract with The Center for Primary Care and Wellness. We are available to answer any questions, Mrs. Sylvia Cruz and Ms. Valeria Ibarra are here.

Mr. Roy Vela responded Ms. Ybarra one of the concerns that I have is this we just got a report on Monday, I work for Driscoll Health Plan one of the concerns is, as we all know, one of the most expensive claims are Hospital claims, and I would like to know and for my colleagues to know is there a report that you generate. I know that you all did it, I believe for the consultant. How much money has been spent on claims? Do you have that number by any chance?

Dr. Perez responded but the hospital is not tied to The Primary Care Wellness. Is it?

Mr. Roy Vela responded no, I'm just making examples of the matter.

Dr. Perez responded ok.

Ms. Valeria Ybarra responded in the general area top five are (inaudible) at Renaissance is at \$2.1 million, University of Texas MD Anderson Cancer Center is at \$1.3 million, McAllen Hospitals is at \$1.1 million, Texas Children Hospital is at \$895,000.00, and the then the largest is Mission Hospital at \$505,000.00.

Mr. Roy Vela responded what was the savings on the PCW Clinic?

Ms. Valeria Ybarra responded it is about \$23,000.00 estimated.

Dr. Perez responded okay, however, when you compare what Mrs. Cruz showed us last week was the difference in cost per visit. which was part of the agenda item.

Ms. Ybarra responded right. The average pay per visit is \$84.57, and for other clinics is about \$96.00.

Mr. Vela asked what is the difference? What is that? I didn't understand that portion.

Ms. Ybarra responded the way the recommendations is made is we review the total spent on that specific medication with came out to \$260,000.00, the deal that is currently in place a quick overview was that there is a 9% discount.

Mr. Vela responded which is like a 9% discount.

Ms. Ybarra responded yes, so if a member goes to this specific location on top of the care that they are receiving and all of the added benefits of that we process in giving your discount plus the 9%. So that is the total benefit of them going to that specific facility.

Mr. Vela responded the current PPL discount for Blue Cross Blue Shield is 65-67%. Is that correct?

Mrs. Sylvia Cruz responded yes that is correct that is the discount percent for Blue Cross Blue Shield.

Mr. Vela responded so if you add 9% to 65-67% it would be 76% by PCW.

Mrs. Sylvia Cruz responded yes it's 9% down more.

Mr. Roy Vela asked do we know how much we spent in other positions and other clinics?

Dr. Perez responded Sylvia, you have that data from last week.

Mrs. Sylvia Cruz responded yes, just for the Board to know as far as professional services, we have 963 doctors that have utilized this plan. We have 963 Doctors, Physicians, and Specialists.

Dr. Perez responded and you mentioned something, correct me if I'm wrong on average there were like 40 visits per doctor. In contrast to so many with PCW. That's what I heard last week.

Ms. Ybarra responded with the information that was comparing our visits to other facilities that are similar. Just quickly reading through the information the total visits through PCW was 3,081. That is through October 1, 2020, through September 1, 2021. Average for other clinics that are similar that can treat the same type of conditions or reasons why they're going to this plan was about getting one. Additional information was just the average paid per visit at PCW was \$84.57 versus other plans was \$96.73. That's every time a member goes that's the average that they're paying. The reason for the recommendation was because of the 90% deviation of these discounts. That's the advantage of having that direct contract is because they got your employee's permission solid at the School District that's covered on the plan to go to this facility and they're able to have access to care very quickly, number one, and then number two they're also receiving an additional discount.

Dr. Perez responded and the fact of the low copay of \$10. That's why it's high, because otherwise and I can tell you last year, a bus driver came to us and said, you know, I've had not been able to come to work because I could not afford a \$500.00 X-ray and here, I got it for \$10. She was crying.

Mr. Roy Vela asked the DHR Providers or any South Texas Health Services Providers. Do we have the (inaudible) for those entities for those groups?

Ms. Ybarra responded no we don't.

Mr. Roy Vela responded let me get to the point. This is what I am going to try to get to because it's \$2.1 million dollars spent in claims to the DHR. DHR does not only encompass facilities, but it encompasses providers and physicians and specialists and all of that if we were to add, or give them, the 9% discount. This is just an example. That's a saving to the district for that one year of \$189,000.00 more less because what you presented right now is that the DHR total money that was spent at the DHR facility was \$2.1 million dollars, if the District if I'm not mistaken, you also stated earlier that Dr. Stinson gives the District and added 9% more less of a discount. So, I brought this up because on Monday we were all presented on how much money is being spent just in DHR. This was on the Agenda, I decided to ask and I decided to dig into this to see where the District can save the most monies. Because, DHR buys all the facilities, not only the facilities but all the Physicians. So, they build under the umbrella of DHR, my point to that is this District will save more money just this alone. What you just presented. How much was paid off \$2.1 million dollars at a 9% discounted rate? The district would receive \$189,000.00.

Dr. Perez responded DHR has an opportunity to submit a bid three years ago.

Mr. Roy Vela responded I understand that, I am just asking to see if the best option right now for the District is to go out for bids or to renew because at the end of the day, we were in the red and at \$28,000.00 I'm super appreciative to Dr. Stinson. At \$28,000.00 is a discount, but \$189,000.00 in just in the facility speaks volumes. One of the things that I can tell you right now, is that this Board is 100% committed to saving money without compromising the well-being and healthcare of every single employee and their families that are insured with the District.

Dr. Perez responded can you explain the \$189,000.00?

Mrs. Petra Ramirez stated the thing is that it's not up for renewal, because there was a mistake a typo. With all the respect to Dr. Stinson and the clinic.

Dr. Perez responded Mr. Hansen what happened was there was a typo and out of courtesy to the Board were bringing it back. It was approved for three years. That's on records on the minutes. The fact that there was a typo on the contract. We want it to be transparent to the Board and bring it back. Because it was a typo it ended this year. That's why we didn't go for bids.

Mr. Hansen responded it's a renewal because it's in the records show when it was originally approved, it was for a period of three years, but the contract itself is for two years. I need to add something though because if it's a discussion of bids, it's important to know, I can give you some legal advice in close but it's a sort of thing. It's just knowledge and procurement and common law procurement of professional services. Medical Services are professionals and so in order to do a big request for services for medical services you do an RFQ and that means that your first consideration is always qualifications that you can't even consider monetary value until after. I just wanted to clarify that the original procurement was done through an RFQ and so that just means that there's a two-step process in the professional services procurement act and so step one is to consider qualifications. And then you're only allowed to pick one. Then you go as the most qualified based on their demonstrated competence and qualifications. And then you're allowed to negotiate without one only. You can't negotiate with multiple providers and then if you can't reach an agreement with that number one then you have to terminate that negotiation in writing and move them on to the next. It's just to the point and it certainly is a procurement nerdism. It's just a peculiarity that has to do with specifically with the type of service. The procurement is somewhat disconnected from some of the costs. If you do go up for another request, if you decide not to renew the agreement then if you go up for another request the request for qualifications and the first consideration would have to be qualifications and not pricing.

Dr. Perez asked and at this point right now, in terms of laps of services, let's say that the Board says tonight, you know what? We're not going to renew it. So, what would happen to our employees? They would not be able to utilize that service?

Ms. Lorena Garcia responded if I may say something there is nothing that prohibits us from doing a direct contract with DHR if they're willing to offer the 9% discount, correct me if I'm wrong Valeria. I know we talked to Zach about this because we were very interested to have a contract with the hospitals. However, there was a difficulty, it was challenging enough to get the PCW approved by Blue Cross because they're very particular with that. But we have tasked Zach to work with Mission Hospital, DHR, and so forth to put them out there and we were unsuccessful in securing a direct contract. Absolutely, this is primary care, this is a family practice. This is not the DHR level. Yes, they have their clinics and so forth, but as far as the money is concerned, that's your Hospital Services, your high-level EKG, and so forth. That's separate and apart from what Dr. Stinson offers if DHR is willing to come forward with a 9% discount we don't even have to bid that, we would just work through Blue Cross Blue Shield, they can always go lower. We've been unsuccessful in the past in securing them because it's my understanding that Blue Cross is very protective of their discounts. I'll let Valeria share more light on that.

Ms. Valeria Ybarra responded Blue Cross Blue Shield already has the deepest discounts compared to most of the other carriers that are available within this general location. We'll start out by saying that which is why they're very particular in direct contracting. Your additional discounts may not be as deep as 9%. I want to say the reason why the agreement for the 9% deviation and discounts is due to the types of services that are making records which is usually Clinical Services, so they're going to cost a little bit less already, which is why that agreement was approved by Blue Cross Blue Shield. That's as much information as I can give you.

Mr. Gonzalez responded and stated I propose we move with the approval to renew the contract with The Center for Primary Care and Wellness PCW.

Ms. Minnie Rodgers responded I think one of the things that our people in Mission are really grateful for is that they don't have to travel so far. I don't know what's the closest thing that we would have to go to DHR.

Dr. Perez responded the thing is that it's a \$10.00 copay. I'm sure if they want our business, they'll set a shop across the street, they'll work with us, but as Ms. Garcia said, we did explore that but Blue Cross Blue Shield holds the credits.

Mr. Roy Vela responded the only thing that I was looking at is where is the District going to save the most money.

A motion was made by Mr. Juan Gonzalez for approval to renew the contract for one year with The Center for Primary Care and Wellness PCW. Motion second by Mr. Roy Vela. Motion passed unanimously. Vote 7-0

X. Approval of Minutes

- 1. August 4, 2021 Board of Trustees Workshop**
- 2. August 4, 2021 Special Board of Trustees Meeting**
- 3. August 11, 2021 Public Hearing**

4. August 11, 2021 Regular Board of Trustees Meeting

A motion was made by Ms. Minnie Rodgers for approval of Minutes #1 through #4. Motion second by Ms. Iris Iglesias. Motion passed unanimously. Vote 7-0

XI. Board of Trustees Information Items

- 1. Personnel Employment, Resignations, Transfers, and Compensation Changes**
- 2. Tax Levy Adjustments for the Month of September 2021**
- 3. Financial Reports for the Month of September 2021**
 - a. General Fund and Debt Services**
 - b. Self-Funded Health Insurance Fund**
- 4. First Quarterly Investment Report for Fiscal Year 2021-2022**
- 5. Cash Disbursements for the Month of September 2021**
- 6. City of Mission Interlocal Agreement for the Natatorium Facilities**
- 7. 2021 – 2022 Annual Budget Report ASBO**

Dr. Perez stated all of these items were discussed during last week's Board Workshop. If there any questions on these items?

Ms. Iris Iglesias responded I have a question about the swimming pool. I saw on the breakdown, that we pay the city \$10,200.00 for the use of the swimming pool, is that correct? Have we've been doing that, year after year?

Dr. Perez responded yes.

Mrs. Iris Iglesias responded because usually, we've had a kind of general gentleman's agreement, they use our facilities we've used theirs.

Dr. Perez responded was that before the District took over the swimming pool at Mission High School?

Mrs. Iris Iglesias responded we've always had that.

Dr. Perez responded they are no longer utilizing our facilities for anything.

Mr. Joel Garcia responded the agreement that we started off with was that there was a small fee that is paid to the city for the use of the pool. Right now it has not been finalized it is with legal, but that's the estimated cost to the District to be able to use the facilities.

Dr. Perez responded but it has been paid for years, right?

Mr. Joel Garcia responded yes it has.

Mrs. Iris Iglesias responded just to use Bannworth Pool and the Mayberry Pool. And the Sharyland Pool?

Dr. Perez responded we can definitely find out.

Mr. Garcia responded we can find out.

Mrs. Iris Iglesias responded because we had that agreement before so I was surprised when I saw it.

Mr. Garcia responded we can reach out to the officials to see how they can better help the District.

Mrs. Iris Iglesias responded because remember they used to have Gus and Goldie and other programs and that is where I know that an agreement had come into place and we just recently turned it over to the District purchase it last year or so.

Dr. Perez responded no when I got here it had already been done. When did the District take over?

Mr. Garcia responded possibly four years.

Mrs. Iris Iglesias responded and the other thing I know we discussed a little bit about last week Lorena was on the heaters. Are we looking at two additional heaters?

Mr. Joel Garcia responded yes as a matter of fact we had put out requested quotes for full facility maintenance and we received some responses. We have a vendor that we are working with now and they are going to be able to provide that type of service.

Mrs. Iris Iglesias responded but are we hiring someone to be there full-time?

Ms. Lorena Garcia responded yes, we are. The gentlemen accepted the job today, we are just pending the DPS background check. We are signing him on early in December. We still have one more vacancy. We are going to be exploring expanding to the heaters because one heater is not adequate for the size, but that will have to be a construction project. We will be working with the Engineer with Mr. River's team because that would be like a full-blown construction project. A major project.

Mrs. Iris Iglesias responded I know the coaches have been doing the chemicals and all that.

Ms. Lorena Garcia responded the gentlemen that were helping out had not been there in a few days, recently Coach Colunga has been informing us that they have had to be putting in the chemicals and so forth, but I did meet with Mr. Castaneda as a matter of fact, yesterday. We spoke and we talked about assigning, someone from Maintenance to be there. Somebody that we could train so that if the gentlemen are not able to go, we have someone to substitute so the coaches don't have to do that.

Mrs. Iris Iglesias stated there is a certification involved in all that.

Dr. Perez responded Yes, ma'am and the outsourcing by when will they be able to start helping us?

Mr. Joel Garcia responded already I think we got the approval midday yesterday. We did the evaluation, tabulation, quotes, and all of that. I think we were just pending open purchase order for maintenance to open it up and then we could already start contracting with that person so they can do the maintenance.

Ms. Lorena Garcia responded he was scheduled to go in today because the diving team had to go use the Bannworth pool because there was a problem with the pool one day out of the week. So, he was scheduled to go in today. I'll check with Coach and Mr. Castaneda to see if he did.

Mrs. Iris Iglesias responded all I ask is to include the Coaches, Coach Colunga, Coach Reyna if anyone knows about that pool. They do. They need to be in the process.

Ms. Lorena Garcia responded yes, they do. In one of the emails that I sent over to Mr. Castaneda yesterday as a matter of fact when we spoke there were emails from Coach Colunga that has been sent to me by Coach Longoria. He's providing up-to-the-minute updates on the swimming pool. All of that I sent to Mr. Castaneda and that's what he was going to work with the gentleman in maintenance to be able to be a backup.

Ms. Iris Iglesias responded they were talking about acid and things like that and they should not be held responsible because those kids get in the water, not the coaches.

Dr. Perez responded absolutely not. It has been a burden on our coaches and that is the reason why we are hiring two versus one individual.

Ms. Iris Iglesias responded we should compensate them a little bit.

Dr. Perez responded you know, that's exactly what I brought up to Coach Longoria. I said, we have that \$3,000.00 stipend that I can always go to the Board and I was told no, they don't want to do that because they've got classes. They've got their sports. They've only done it because they had to, to keep it afloat, just to get us the help and that's when I called them and I said, you know what, let's outsourced let's get somebody by next week, and so forth.

Ms. Iris Iglesias responded if they would have just left it to. Hey, you know, no thanks to it. Their kids would not have been able to use it. It's through their love for what they do. They want to make sure their kids are not left out. It does need to work both ways.

Dr. Perez responded yes ma'am that's why we got to do it.

Mr. Gonzalez responded is it as other duties as assigned also.

Dr. Perez responded it has become a burden because every morning they have to track the water levels. They have to put pounds and pounds of chemicals, it's a lot. The good thing is we've outsourced. We've never done that also, now the pool is going to be under the Maintenance Department and not the Athletic Department.

Ms. Iris Iglesias responded Thank you.

XII. Important Dates to Remember

- 1. November 22-26, 2021 Thanksgiving Break**
- 2. Staff and Students return November 29, 2021**
- 3. December 8, 2021 Board of Trustees Workshop at 6:30 p.m.**
- 4. December 15, 2021, Regular Board of Trustees Meeting at 6:30 p.m.**
- 5. December 20-31, 2022 Winter Break**
- 6. Staff returns January 3, 2022**
- 7. Students return January 5, 2022**

XIII. Executive Session

President Zamora called the Board into Executive Session at 9:57 p.m. and back into Open Session at 10:54 p.m.

- 1. Private Consultation with Board Attorney (Texas Gov't Code §551.071)**
- 2. Deliberate the Appointment, Employment, Evaluation, Reassignment, Duties, Discipline, or Dismissal of a Public Officer or Employee or to Hear a Complaint or Charge Against an Officer or Employee (Texas Gov't Code §551.074)**

XIV. Actions, if Necessary, on Matters Discussed in Executive Session

VIII. Discussion and Possible Action

1. Recommendation and Approval for the Selection for:

a. ESSER II, Bryan Elementary School Counselor

Dr. Carol G. Perez stated that Administration recommended Pricilla Ann Aguirre for the position of ESSER II, Bryan Elementary School Counselor.

Motion made by Mrs. Betty Mendoza to approve. Motion second by Mr. Roy Vela. Motion passed unanimously. 7-0

b. Mission Jr. High Counselor

Dr. Perez stated that Administration recommended Evelyn G. Bermea for the position Mission Jr. High Counselor
Motion made by Mr. Juan Gonzalez to approve. Motion second by Mrs. Petra Ramirez. Motion passed unanimously. Vote 7-0

XV. Adjournment

Motion made by Mrs. Petra Ramirez that the meeting is adjourned. Motion seconded by Mr. Juan Gonzalez passed unanimously. Vote 7-0.

President Zamora adjourned by 10:56 p.m.

Jerry Zamora, President
Mission CISD Board of Trustees

ATTEST:

Roy Vela, Secretary
Mission CISD Board of Trustees



Mission Consolidated Independent School District

- 1201 Bryce Drive • Mission, Texas 78572
- Telephone (956) 323-5505 • Fax (956) 323-5634
- Website: www.mcisd.net

Board of Trustees Minutes

The Board of Trustees of the Mission Consolidated Independent School District held a **Special Meeting on Wednesday, December 8, 2021, scheduled to begin at 7:30 PM** in the **Mission CISD Annex, 925 E. Business HWY. 83, Mission, Tx 78572.**

I. Call to Order and Establish Quorum

Vice President Betty Mendoza called the meeting to order at 9:26 p.m. The meeting was properly posted; a quorum was present. Board Members present were Petra B. Ramirez, Iris Iglesias, Juan Gonzalez (joined remotely), Minnie Rodgers, Betty Mendoza, and Dr. Carol G. Perez, Superintendent of Schools.

II. Pledge of Allegiance and Moment of Silence

1. U. S. Flag and Texas Flag –

Mrs. Betty Mendoza led in the Pledge of Allegiance and she also asked for a moment of silence.

III. Comments from the Public

None

IV. Public Comment(s) on Specific Agenda Item(s)

None

V. Superintendent's Updates and Recognitions

Dr. Carol G. Perez, Superintendent, informed the Board of the following and stated: I would like to give an update regarding the City of Mission all-inclusive part fundraiser. This fundraiser is from Central Administration our Executive Leadership Team. We also challenge our schools. It's not required, but we talk to them about how we would, like every single campus represented when we do provide the check to the City of Mission. We are very excited that our City did receive a grant to build an all-inclusive park that will help out our children with special needs and it will be open to all children and all of our Community. In consultation with legal counsel, we as a District cannot make a monetary donation because we do not own the property. We did commit that we would, as staff members, because we believe in the project and that it is good for children and the community that we will hold some fundraisers. We talked to the campus principles about it as well. At Central Office as an Executive Leadership Team, we brainstormed as to the type of fundraisers that we could come up with, and the first one Mrs. Wilson lead it, and of course in collaboration with everyone else and we donated baked goods and before Thanksgiving, we had an auction of baked goods and we collected \$711.00 with our little central office staff and of course maintenance, operations, and the Annex and so forth. We got that. Then we also brainstormed and Mrs. Risica led the wearing of jeans the week before Thanksgiving. We set a collection fee of \$10.00 and the staff could wear jeans for the whole week before Thanksgiving. We liked it so much that we did generate \$720.00, but because we had also announced that the last week before Christmas we were going to do it again. A lot of people paid for both weeks, so we wanted to hit the \$1,000.00. We said "what if we do the same for the last two weeks before the winter

holidays”, so we have generated a grand total of \$1,150.00. Last week we held an auction of crafts and baked goodies. Many of us have items in our home that we don't use that we can bring. We did it as a team effort and that generated \$800.00. Then Mrs. Frances Cruz’s idea was to have a pancake and sausage breakfast fundraiser. That's taking place next week on Thursday, the 16th in the morning and we have a projected amount of \$950.00 more or less. The grand total raised so far is \$3,611.00. Future plans are the week before spring break we're going to do another jean week and that will probably generate \$400.00. We also have another big auction on Friday, a baked good auction. We are planning for a rummage sale in our parking lot after the winter holidays and then maybe another one after spring break. We are hoping that we can raise the \$5,000.00, but if we exceed \$5,000.00 that would be great. And that's only from our executive leadership team and our Central Office staff. The central office includes the Annex, Maintenance, and Operations because they do also contribute. The campuses will be doing their own. We're very excited to be able to contribute. Also, something that's happening that we're very excited about is the toys drive with Special Education Services.

Mrs. Frances Cruz, Executive Director for Special Education stated we have our float that's going to go out to the campuses and visit, our Special Education students in our units and we are going to be delivering those gifts. We did have everyone that wanted to contribute a gift and we were able to meet our quota and this is all employees. Our kids wrote letters to Santa. We posted them up and everyone that wanted to help went by and picked one or two kids. The neat thing about this is that they're getting what they're asking for in those letters. Everything we do in the Special Education Department is individualized and so are the gifts. We're looking forward to that event.

Dr. Perez stated that we also have a Toys for Tots box at Central Administration that a Community member brought if anyone would like to donate a toy. Now for the big the one, and we want to start working on this so that we can roll it out. Hopefully, second semester. We are going to be asking our District Educational Improvement Council to meet because we would like to revise our dress code for students and staff. One of the things that the pandemic has taught us is that when individuals wear comfortable clothing, they are much more effective at work. We can empower them, especially when they're in the classroom. If we want them to have real fun, then we need to make sure that people are wearing comfortable shoes, comfortable clothes that lend themselves to the activities that they're doing in the classroom with students. So, we would like to look at the dress code and revisit. If children feel comfortable with their dress code. They're going to want to come to school. If staff is comfortable. They're going to be much more productive. We will be meeting Monday afternoon at 4:00 p.m.

Mrs. Kim Risica, Executive Director for Special Programs and School Improvement, stated we have a meeting scheduled. I've been doing research and different districts in the area and up the State as well as what their dress codes are. I'll be sharing those dress codes with the DEIC and then I'll have Ms. Garcia, help me with that. So, she'll be presenting that information as well.

Dr. Perez stated hopefully we can bring it back next week to you.

VI. Recommendation and Approval of the Selection for:

- 1. Special Education Behavior Specialist**
- 2. Special Education Licensed Specialist School Psychology**

Dr. Perez stated recommendations will be discussed in Executive Session and brought back in the open session.

VII. \$1,000 New Teacher Sign on Bonus for all Spring Semesters Hires

Dr. Perez stated Administration would like to recommend that the Board of Trustees approve the \$1,000.00 New Teacher, Sign on Bonus for all teachers that are hired for the Spring.

A motion was made by Mrs. Petra Ramirez for approval. Motion second by Mrs. Iris Iglesias. Motion passed unanimously.
Vote 5-0

VIII. Action, if Necessary, on Matters Discussed in Executive Session

- 1. Private Consultation with Board Attorney (Texas Gov't Code §551.071)**
- 2. Deliberate the Appointment, Employment, Evaluation, Reassignment, Duties, Discipline, or Dismissal of a Public Officer or Employee or to Hear a Complaint or Charge Against an Officer or Employee (Texas Gov't Code §551.074)**

Vice President Mendoza advised the Board will now go into Executive Session at 9:42 p.m.

Vice President advised it is 10:15 p.m. returning from Executive Session.

IX. Action, if Necessary, on Matters Discussed in Executive Session

a. Special Education Behavior Specialist

Dr. Perez stated that Administration recommended for the Board of Trustees to approve Eduvina Barrera-Lopez for the Special Education Behavior Specialist.

Motion made by Mrs. Petra Ramirez for approval. Motion seconded by Ms. Minnie Rodgers. Motion passed. Vote 5-0

b. Special Education Licensed Specialist School Psychology

Dr. Perez stated that Administration recommended for the Board of Trustees to approve Nelida Evangelista for the Special Education Licensed Specialist School Psychology.

Motion made by Mrs. Iris Iglesias for approval. Motion seconded by Mr. Juan Gonzalez. Motion passed. Vote 5-0

X. Important Dates to Remember

- 1. December 15, 2021, Regular Board of Trustees Meeting at 6:30 p.m.**
- 2. December 20-31, 2022, Winter Break**
- 3. Staff returns January 3, 2022 – Workday January 4, 2022 – Staff Development**
- 4. Students return, Wednesday, January 5, 2022**

XI. Adjournment

Motion made by Mrs. Petra Ramirez that the meeting is adjourned. Motion seconded by Ms. Minnie Rodgers. Motion passed. Vote 7-0

Vice President, Mendoza adjourned the meeting at 10:20 p.m.

Gerardo Zamora, President
Mission CISD Board of Trustees

ATTEST:

Roy Vela, Secretary
Mission CISD Board of Trustees



Mission Consolidated Independent School District
• 1201 Bryce Drive • Mission, Texas 78572
• Telephone (956) 323-5505 • Fax (956) 323-5634
• Website: www.mcisd.net

Board of Trustees Minutes

The Board of Trustees of the Mission Consolidated Independent School District held a **Regular Meeting on Wednesday, December 15, 2021, at 6:30 PM** in the **Mission CISD Annex, 925 E. Business HWY. 83, Mission, Tx 78572.**

I. Call Meeting to Order and Establish Quorum

President Jerry Zamora called the meeting to order at 6:36 p.m. The meeting was properly posted; a quorum was present. Board Members present besides Jerry Zamora were Petra B. Ramirez, Minnie Rodgers, Roy Vela, Iris Iglesias, Juan M. Gonzalez, Veronica R. Mendoza, and Dr. Carol G. Perez, Superintendent of Schools.

II. Pledge of Allegiance and Moment of Silence

Mr. Jerry Zamora led in the Pledge of Allegiance and she also asked for a Moment of Silence.

III. Comments from the Public

Mrs. La Quanta Bivens-Hernandez addresses the Board on Advocating for the Children.

IV. Public Comment(s) on a Specific Agenda Item(s)

NONE

V. Superintendent's Updates and Recognitions

Dr. Perez informed the Board of the following: The Board update, regarding the school support grant that we had already advised the board that we received last spring. This grant comes from the Texas Education Agency and we applied for it and we could apply for it for different populations, At-risk populations. One of the greatest needs for us is the emergent English Learners and the Texas Education Agency is providing funding it is requiring our school district to provide a Texas COVID Learning acceleration supports data fellow and they are providing the salary for this individual. So, it is a position that this individual will assist in enhancing the data collection to inform instruction for emergent English Learners, and the individual will be working under the direction of the Bilingual Department. We also received notice just today from the Texas Association for school business officials that our school district and purchasing department has received the merit award for the second year. So, congratulations, an update on the Mission, CISD Citrus Orchard. And, you know, the ultimate goal is to build our bus barn there. However, we've taken advantage of our students taking a lot of classes and our teachers are working also with the orchard. So right now, the orchard is ready to begin harvesting many of the oranges. And so, some of the oranges have already been picked up. The remaining ones will be picked up during the holiday break. However, we would like to share some of the harvests with our School Board and our district employees, and also our partners. Our culinary arts classes will be able to come up with some recipes for desserts. And that's what we will be sending gifts of appreciation to our partners. The majority of the fruit will be sold for juicing locally. And I was told by February, we will have 13 acres of grapefruit. So, get ready for those, great fruit pies coming along. We also have finished the farmer's logo and our PR department has worked very closely with our CT Director, Dr. Roberts. And so, we have our Farmers logo ready to be published and Farmers is an acronym for Farmers agriculturists ranchers, machinists, engineers, and suppliers. And this program is not only to be utilized at Citrus Grove. But we do have innovative courses in our high schools. And right now, we have many gardens, and vegetable gardens in our schools from pre-k 3 all the way through 12th grade. As a matter of fact, I know that. Mr. Verley will be putting it out on Facebook today over at Mission High School. The students in those classes were able to harvest a lot of their vegetables. They brought in a lot of greens that kids have never tasted before and so they were able to put them out for the students to enjoy different kinds of lettuces. It is different kinds of

greens and so the kids have a good time trying new vegetables. For the second semester, we are getting ready for a virtual convocation and you know with holidays and things like that, we want to continue to be proactive and make sure that we do not bring huge groups of people together. So, our kickoff for the second semester is being recorded by our PR staff. We will be able to have the virtual session on the first date, back on January, 3rd for all of our employees. January 4th, for all of our employees. Tonight, we have a very special presentation. I know that the board received a wonderful winter holiday card. You did get it in the mail, right? And many of our Community Partners received it, including our service center, our campus administrators, our district administrators, and all superintendents from the Rio Grande Valley. Our Fine Arts department held a winter holiday card contest. So, the top 15 cards were selected and then narrowed down to about three. We selected the top card, that would represent the mission CISD Team of Eight-holiday card. So today we would like to honor Sergio Vasquez, a 12th-grade student from Mission High School with a token of appreciation and something very memorable for his artistic talent, we'd like to welcome, Sergio. Our Fine Arts Director and the Board would like to present this token of appreciation and then take lots of pictures. Sergio, on behalf of the Board of Trustees and the Administration, we'd like, to recognize you for your artistic talents. Thank you for being such a great inspiration. Congratulations.

VI. Presentation(s) to the Board of Trustees

1. District-Wide Climate Survey Administered by TASB

Deputy Superintendent for Support Services, Ms. Lorena Garcia presented on the District-Wide Climate Survey Administered by TASB.

TASB representative presented and stated good evening. I'm Janelle Guillory and I'm an Assistant Director in the TASB HR services division. I'm glad to be here this evening to discuss your employee opinion Survey. First, we'll cover some administrative information about the survey. The survey was conducted online by sending email invitations and reminders out to District employees. And a link was also provided by the district, so that staff could participate even if they didn't have regular access to a computer or they didn't receive that email reminder. This is the first year we've conducted the survey for your district and the district worked with campuses to incentivize participation and make sure that employees had, that chance to be heard and HR Services administered the survey on behalf of the district. So that it provides a layer of confidentiality and helps respondents feel more comfortable answering questions. You get the data without the employees feeling at risk or exposed by their answers. What we found was that you had 2095 employees respond, which is a 93 percent participation rate. That is a very strong participation rate. Employee surveys across all industries, tend to be sixty to seventy percent. And for the school district ones that we do in HR Services. It's often 75 to 90. Generally. We also see larger districts, like yourselves, having lower participation, so, you've succeeded on several fronts there and should be congratulated for getting such good participation from your employees. Also, we find out that first-year surveys have higher participation because there's more employee interest and it might dip down in future years, but it's not something to worry about. As far as demographics we ask employees right at the top what their job type is and that lets us show them specific questions based on that answer. So, teachers, instructional support, and auxiliary were the largest groups that your employee demographics, so it all lines up there. As far as their time with the district respondents had a pretty wide range of experience, which is good. We want them to represent all of your employees and just over 20% had three or fewer years with the district. Well, 30% have been with you for 16 years or longer, which is really shows the employee tenure y'all have and then additionally people were well distributed across work locations in the so this next slide will show campuses the largest group came from the employee, the elementary campuses, which is expected followed by high school with some of your departments being much smaller portions. So, all of that lines up with your employee demographics. So now, you know a little bit about how the survey was done and who responded then I want to talk about how the responses are summarized. For the most part, these employee surveys are really about comparing to yourself, where you expect it to be, and where you want to be. And then if you continue annual surveys with TASB, you'll get to see those comparisons added each year in the report and in presentations. And that is a kind of internal focus, the reason we do that is because there's no statewide benchmarking data because districts may or may not do employee surveys. And they may do them through a variety of providers or survey systems and ask all different questions. So, the surveys were really about comparing to yourself on an ongoing basis. There are a few items where from my six years doing these in HR Services. There are clear patterns and I'll call those out where you line up with those so that you know, but for the majority, it really is individual by district what these patterns show. Now we'll talk about factors in job satisfaction. If you'll click again, it will display some extra info. So, respondents were asked to pick the top five factors that influence their job satisfaction, and here are the top choices across all employee compensation and benefits was the biggie, it was 58% of respondents said that it influenced their job satisfaction. That's followed by respectful treatment of all employees at 57%, and job security at 47%. So, there are items that you'll see in the full report that was selected by far fewer people, but they may be crucial to district operations. It doesn't mean that they're not important. It just means they weren't at the top of people's minds when they think about their day-to-day job satisfaction. So, the bulk of the items on the survey was asked in the form of a scale with a statement shown and answers ranging from strongly agree to strongly disagree, as well as the no opinion option for what we'll talk about. The strongly agree and agree categories have been combined to indicate a positive response. I'll cover the highest agreement in each topic which will show in green as well as the lowest shown in yellow. This is intended to give you a sense of the range of responses and you'll see more details in that full report in the packet. As you'll see when we go through it, the lowest item may still have really strong responses that are positive. So yellow is not necessarily a bad thing, it's just part

of color coding to see that range. For job satisfaction, the highest item was liking the work with 97 percent agreement. So nearly everyone likes the work they do and then here's a perfect example where that lowest item would recommend the campus or department to a friend as a good place to work. Still has the vast majority of respondents agreeing with 84%, and then moving on to working conditions, 90% of your respondents, feel secure in their employment, with the district, the lowest item here with 70% agreeing, that the workload is appropriate for their position to further put that into perspective even the lowest item still had more than twice as many people agree as disagree, or saying they had no opinion. So, it's still a strong positive response, giving you that extra perspective there. Relationships with coworkers and supervisors are really day-to-day things that can make or break, someone's workday, or coworkers. It was all good news, 96% like the people they work with, and the lowest but still very high at 90% was that they can depend on their co-workers. Relationship with supervisor 89 percent say they trust their primary supervisor to act in the best interest of students. And then the lowest had a tie for two items, 64 percent reported that in the last two weeks they've received recognition or praise for my doing a good job. And the same percent said that this year, their Supervisor has talked to them about their progress. So, we'll move up a level from that co-worker and supervisors to compensation, 85% of your respondents agree that they get help with problems and questions about their benefits. However, the lowest item in this section is 56%, agree pay is fair for the work done. So, although this item is notably lower than the lowest and prior sections. It is still a majority agree and this is a place where I can definitely say that compensation items are routinely the lowest-rated items in the district. It's often just part of being in the public sector and being public servants. The district does annual pay system maintenance services with HR Services, which help the administration and the board, keep an eye on the local market and pay planning to use those compensation funds to the best of your ability. Now, we'll continue moving upward to bigger picture district items, beginning with communications, 92% agree that the district recognizes employee accomplishments, for example, teacher of the year staff member of the year service awards, and social media posts. At the lower end, 71 percent agreed that employees have a way to express their concerns to the district. This employee survey is absolutely one method for that, but others might include anonymous, year-round forms, focus groups, are town halls just to cover all the different ways that employees might need to get information or have that dialogue. Then for district leadership, there were three items shown to respondents. And so, we're catching the top and bottom in the middle is the left out one. Eighty-four percent, believe the district leaders work with standards of educational, practice, and 75% believe the district leaders value the employees of the district. So those are very close in range and are positive. From there we see some campus environment items in this section were shown only two teachers and your campus instructional support that way the questions were as relevant as possible to those respondents. There were four items shown and two were ties so you can actually see all four items. They're quite close together. Is that 88 percent or campus is being clean and properly maintained and the principal treating them with respect, then only slightly lower at 82%, we're getting the information needed from campus leaders and the principle being effective in leading toward the campus's goals. From there we moved to some curriculum and instruction items, we further narrowed that respondent group. Now, it's only teachers 92% of your teacher respondents believe that teachers were held to high professional standards and 68% believe that teachers are special populations that receive adequate resources. Similar to that compensation question this one has a clear trend among all the districts we work with. It's usually the lowest item in curriculum and instruction but it is a good sign that you have more two-thirds agree. We don't always see that it's often closer to half, then we continue with those teachers only respondents ask about student discipline. Eighty percent agree that the principle provides leadership in behavioral standards and 71 percent agree that the code of conduct is consistently and fairly enforced. From there we go to a different narrow down group of respondents based on the district's request we showed additional questions to employees who worked in fine arts or Athletic programs for this school year for Fine Arts a total of 218 respondents and for Athletics it was 194. So, they do represent a small subset of employees, but we know that their programs that cross campuses and impact a wide variety of your students. So, beginning with the campus level fine arts program supervisor, these were shown only two respondents, who checked that they worked in a fine arts program this year. 87% agree that they can communicate openly with their program supervisor 68% afforded that in the last two weeks, they received recognition or praise for doing a good job from that program supervisor. Then moving up a level to the district level fine, arts program, director, 91% agreed their director allows them to make decisions within their scope of authority and the same percentage say that they can communicate openly with the program director 79 percent agreed that the director makes timely decisions. Now, we'll swap over to Athletics. So, these are so not only to the respondents to check that they worked within an athletics program. 92 percent agree that they get the training needed to do their job effectively. And then the lower item was 81% reporting that in the last two weeks, they've received recognition or praise for doing a good job. So, moving back up to that district-level athletics program director, 78 percent agreed, that their director allows them to make decisions within their scope of authority and 72 percent agree the director makes timely decisions. Now we'll move on to comments and suggestions comments on the survey came from 730 people or about 35 percent of respondents. Each topic represents only a small subset of employees. So, we always recommend using the comments alongside other results shown earlier in the full report, for example, reviewing the supervisor section with answers from about 2,000 employees, and using the comments to add some flavor and depth to the few hundred who left comments on related topics. Comments are a large open text area, where your respondents can tell us anything they want us to know we read them and categorize them as positive or negative on a variety of topics. A single person's comment may have positive and negative aspects. It might hit upon one topic or 10 and we will tally it for each one that it hits. So, 458 people provided accolades, including the most common accolade, which was that campus leadership and staff are engaged and supportive of students' education and growth. 338 provided complaints and the most common ways that the campus our team had insufficient staffing for the work assigned and the district should be commended here as we typically see more complaints than accolades. But you have that pattern reversed which is good to see. 201 employees, provided suggestions. The most common was to address staff feelings of being burned out and overwhelmed after these past two years.

And 159, listed improvements that they've seen with the most common being the improvement of safely bringing students back this year. And all of the steps that the district went to make that possible for students and staff to come back safely. So, where do we go from here? You've got a lot of information, both my summary here and the more in-depth report. First, we recommend you dig deeper by looking at district priorities and the district may review the campus level information and set priorities with departments. Then you can connect that to goals, both existing district goals for the superintendent or principals or departments. And then look forward to set new goals based on what you discovered and especially areas that surprised you or you just weren't sure what to expect. Those are always good places to set goals now that you have more information and then check back periodically, that can be formal or informal. Whether an annual survey like this or focus groups about a particular program of interest. And I'm happy to take any questions you have about the survey.

Mr. Roy Vela asked, when was the survey completed?

Janelle Guillory responded, let me pull that up real quick. Late September through early, October and so respondents got multiple emails as reminders. If they hadn't filled it out. Once they did fill it out. They dropped off that reminder list, so we weren't hassling more people than necessary.

Dr. Carol G. Perez stated, that the department and the campus principals have not received this information. We wanted to present it to the school board as we normally do first.

Mrs. Petra Ramirez stated, there are more accolades than complaints so it's pretty good. So apparently, we're okay, you know, we have happy people still. It's a good report.

Mr. Roy Vela asked, how do we address the recommendations from employees?

Dr. Carol G. Perez, responded, well, that's the next step. As an executive leadership team, we are going to be reviewing all of this data. First, they sent this information to present to you. Now, we're going to dig deeper as an executive leadership team, and then we're going to every year, you know, how we develop the improvement plans. That's what it's about this is going to inform the next level of work. And this is what's going to help us target those specific areas in need of improvement. And at the same time, celebrate the great things that are going on. So, it has to be balanced after that. Each department will be receiving their information and each campus because that is what we're going to utilize to develop the campus improvement, plant the district improvement plan, which includes all of the departments as well. And so, you know, sometimes we really have to look into this and accept the brutal facts. However, one of the things that has been shared and I've worked at several school districts, this data is amazing. The fact that 99% of our teachers participated that huge and also the results of it. They're awesome results because the school board this administration has worked relentlessly. And of course, you know, when it comes to compensation, you're going to see a 50-50. I mean that's just natural, but you know, that within the last three years, we moved it from number 8, number 9, to number 1, number 2. And when employees have only work in one district and has have not seen, you know, what's available in other places but even then this is an extreme positive. That's what I've seen in other districts is like 60% for the administration and here we have 80 or even lower.

Mrs. Iris Iglesias stated I would like more time, I would like to really study this.

Dr. Carol G. Perez stated, that the board received the packets so they can look at it. Is there any comments that you would like to add?

Janelle Guillory responded, as far as continuing to review it if you are looking to see what exactly the employees saw you'll find it at the very end of the packet the appendix has the survey instrument itself.

Dr. Carol G. Perez responded, Yes, and it's so these are your copies and then as we continue with our board workshops or addressing certain things and then I can also meet with you individually or in small groups or during the Board Workshop, we can review the findings of recommendations, that's what it's for.

Mr. Roy Vela asked Dr. Perez I have a question. Are you going to share with the board because there are 338 complaints? Apparently, there's that's part of our weaknesses, but I would like for us to know what those are so we can turn them into our strengths.

Dr. Carol G. Perez responded those were categorized. Can you address where there at in the packet?

Janelle Guillory responded, yes, it is on page, accolades and complaints are on page 18, and they're organized in decreasing order by frequency. And so, you'll see that the four, most common topics were all accolades. You'll see topics by frequency, such as accolades campus leadership, and educational staff is engaged in support of a student's education and growth. Or complaint campus her team has insufficient staffing or work assignments. These cover all of the topics that we pulled out of those comments. Someone may have written

a paragraph that hit a bunch of different topics. And we pulled them into tallies for individual ones that you can review topics and how they link to the results earlier in the report because you don't want to take just a complaint. For the first complaint, there are only 84 people, but in the charts that cover all respondents, you have two thousand respondents. So, you don't want to ignore what that much larger group of employees said, for some complaints, you want to use the complaints accolades to add flavor to the main results

Mrs. Betty Mendoza stated I agree with Mrs. Iglesias. I want to study this a little bit more. I want to know why some of the percentages are low? What are the concerns? What do our teachers want? What are they needing? What are they disappointed about? Because I do see that some of the percentages are average or good. But I also see some of them that need some improvement. So yeah, I want to study it a little bit more. I want to know what they responded. Exactly what is it they responded if we're allowed to see that.

Dr. Carol G. Perez responded, at this point, this is the district overall. We will also have it by campus and we'll be able to share that with you as well. So, tonight this PowerPoint, this is a summary after finding some recommendations.

Monumental job to categorize and do all of that. And the open response is what takes a lot of time. So, thank you for the work and for providing information and we will continue to work and keep the board informed. On the campuses we do want to give the campus principles an opportunity to see them, work with the executive director, and with our executive leadership team and develop a plan of action, as the areas of need, and at the same time celebrate the accolades.

Mrs. Petra Ramirez stated, these surveys are, you know, are good because we find out where we really are and then but it's like they said, you know, we need to find out where the need is in every campus and that's why we make the survey so that we can have a baseline as to where we're going to gear our everything to. Not that it's just a survey we're going to put it under the bed, you know, and not do anything about it.

2. Tom Landry Stadium Progress Report

Mr. Ricardo Rivera, Assistant Superintendent for Operations stated for the Tom Landry, Stadium repair project, Rick Hinojosa Structural Engineering was designed the team that was selected for this project. The awarded general contractor was RG Enterprises LLC. A notice to proceed was issued to our RG Enterprises LLC on or about July 28th of this year. The original substantial completion was scheduled for on or about February 28th of 2022 at last month's regular Board of Trustees meeting. There was a change order, which included 44 delay days that was presented by R. Hinojosa and the general contractor that was approved with those 44 days the new substantial completion is on or about April 8th of 2022. We have Mr. Adrian Hernandez and Mr. Adan Rivera from the maintenance department that oversees the project on behalf of the district. However, there are just an extra set of eyes to attend the meetings and go look at the project as in the best interest of the district, the design professionals, and the general contractors are the persons responsible. And they are the experts to provide the district with a successful project. We see correspondences going back and forth between the design team and the general contractor. And on occasion, we make a comment. However, it is not our responsibility to advise them on the means and methods of either the design or how to do this project. However, there are some concerns that have been brought up. And last week I sent a letter on district letterhead to both R. Hinojosa Structural Engineering and RG Enterprises LLC that we had Concerns on the progression of the project. We know that they've been coming forward at the Board Workshops every month and giving an update on the project. However, those have been slightly vague. We did have a meeting this morning at the site with all parties and we advised them that they needed to present to the board today and be totally transparent to the board. And of course, to Dr. Perez, the Administration, and the community. We have Mr. Alberto Trevino from R. Hinojosa Structural Engineering as a design team representative. And we also have Mr. Rene Garza from RG Enterprises, LLC that can provide you with an updated report please feel free to ask any questions, so they can be completely transparent and that the board, Dr. Perez, and we all know our concerns.

Alberto Trevino with R. Hinojosa Engineering representative presented.

Mr. David Hansen asked when will there be a set of engineer drawings that you can give to the contractor so that he can price us. For this certain thing you need an engineering solution, right? You have to have some drawings and some specifications to support a change order request. When will those be done? So that you can start that process? He needs to know what he's got to price before he can price it. Is there an ETA on that? There is such a thing in the contract, but its construction change directive still has to be approved by the board. It's basically like a change order except there's still some dispute about the price. Right? So, usually that's what it comes down to. The contractor and the owner will sign it, But the contractor says, I'm not going to sign this yet because I don't agree on the price, right? So that's what construction change directed. A change order is when we agree on everything, right? So, we have an agreement on the price, that change on the work. Since I term was used I just wanted to make sure that you remember that. So, and yes, it's accounted for in the agreement. But under the agreement, that's something I would come back to the board, especially when there's an adjustment in price. Or when it's a change in the work in a construction change directive would require board action because of the nature of the change. So, I just thought it'd be helpful to clarify that.

Dr. Perez stated we will have a Special Board Meeting on January 5th to present a proposal.

VII. Discussion and Possible Action

1. Consideration and Approval of Roof Over-lay for the Mission CISD Annex Building Project

Mr. Ricardo Rivera, Assistant Superintendent for Operations stated the first agenda item I have is the Consideration and Approval Roof Overlay for the Mission CISD Annex. This agenda item was presented at the Board of Trustees Workshop, on Wednesday, December 8, 2021.

Administration presents Consideration and Approval of The Roof Overlay for the Mission CISD Annex Building project.

A motion was made by Mrs. Betty Mendoza. Motioned seconded by Mr. Juan Gonzalez. Motion passed unanimously.
Vote 7-0

2. Consideration and Approval of Change Proposal Request #4 for Replacement of Wood Rafter and Fourteen (14) Delay Days for the Maintenance Warehouse Structural Project – PBK Architects

Mr. Ricardo Rivera, Assistant Superintendent for Operations stated next Agenda Item is consideration approval change proposal request number four for the replacement of wood rafter and 14 delay days for the maintenance warehouse structural project is PBK Architects. This agenda item was presented at the Board of Trustees Workshop on Wednesday, December 8, 2021. We do have Mr. David Iglesias from PVK present if there are any further questions, he was here at the Board Workshop, last week. Administration presents consideration approval change proposal request #4 for replacement of wood, rafter, and 14 delay days. The maintenance warehouse structural project.

A motion was made by Mrs. Petra Ramirez. Motioned seconded by Mr. Roy Vela. Motion passed unanimously. Vote 6-1, 1 abstained by Mrs. Iris Iglesias

3. Approval of First Reading of TASB-Policy Update 118, affecting local policies:

- a. CFD(LOCAL) ACCOUNTING: ACTIVITY FUNDS MANAGEMENT**
- b. CQB(LOCAL) TECHNOLOGY RESOURCES: CYBERSECURITY**
- c. DFE(LOCAL) TERMINATION OF EMPLOYMENT: RESIGNATION**
- d. DP(LOCAL) PERSONNEL POSITIONS**
- e. EHAA(LOCAL) BASIC INSTRUCTIONAL PROGRAM: REQUIRED INSTRUCTION (ALL LEVELS)**
- f. EHBC(LOCAL) SPECIAL PROGRAMS: COMPENSATORY/ACCELERATED SERVICES**
- g. EIE(LOCAL) ACADEMIC ACHIEVEMENT: RETENTION AND PROMOTION**
- h. FDE(LOCAL) ADMISSIONS: SCHOOL SAFETY TRANSFERS**
- i. FEA(LOCAL) ATTENDANCE: COMPULSORY ATTENDANCE**
- j. FEC(LOCAL) ATTENDANCE: ATTENDANCE FOR CREDIT**
- k. FFG(LOCAL) STUDENT WELFARE: CHILD ABUSE AND NEGLECT**

Mr. Craig Verley, Director for Public Relations presented on Approval of First Reading of TASB-Policy Update 118, affecting local policies:

A motion was made by Mrs. Betty Mendoza for approval of the Approval of First Reading of TASB-Policy Update 118, affecting local Policies. Motion second by Mr. Roy Vela. Motion passed unanimously. Vote 7-0

4. Discussion and Approval of Bids, Proposals and Purchases of \$50,000 and Over **a. Award Purchase On-site Before and After School Child Care Services #602-22-1**

Mission CISD seeks to deliver comprehensive education services and resources through child care services subsidized by the Texas Workforce Commission child care services program. Mr. Joel Garcia and Lorena Garcia presented.

A motion was made by Mrs. Petra Ramirez for approval to Award Purchase On-site Before and After School Child Care Services for three years with the option to renew for two additional years. Motion second by Mr. Roy Vela. Motion passed unanimously. Vote 7-0

5. Approval of Budget Amendment

In accordance with TEA budget and accounting procedures guidelines, the District's official budget includes the General Fund and Debt Service. The adoption of the budgets associated with these funds, and subsequent amendments, should be approved by the Board of Trustees. All requests for Budget Amendments, have been reviewed and are justified for the programmatic or policy changes, and adjustments of original estimates. The general fund is increasing by \$90,000.00 in expenditures. The expenditure includes the establishment of a budget for athletic uniforms for all Mission High school and Veteran Memorial High School, Athletic Departments. It also includes the reallocation of Function 11 to various functions to support campus and Department Operations.

Administration recommends the Approval of the Budget Amendment. A motion was made by Mr. Juan Gonzalez for approval. Motion second by Mr. Roy Vela. Motion passed unanimously. Vote 7-0

VIII. Recommendation(s)

1. Approval of the Selection for:

- a. Computer Programmer/Analyst**
- b. ESSER II, Bryan Elementary School Counselor**
- c. Special Education Licensed Specialist School Psychology**

Item was discussed in Executive Session.

IX. Items to Consider: The Board will consider and may act on the following items under a CONSENT AGENDA. Any Trustee may request the removal of an item from the CONSENT AGENDA for individual consideration and action.

Dr. Perez stated Consent Agenda includes from #1 through #8, if the Board would like to move out any item please let us know. They were all discussed in last week's Board Workshop.

Motion made by Mr. Juan Gonzalez that the Board approves the Consent Agenda IX Items #1 through 8. Motion second by Mrs. Minnie Rodgers. Motion passed unanimously. Vote 7-0

- 1. Approval to Accept Schematic Design for the Demolition of the Technology/Radio Tower Project – Chanin Engineering**
- 2. Approval to Accept Schematic Design for the Child Nutrition Program Walk-in Freezers for Bryan, Marcell and Salinas Elementary Project – Chanin Engineering**
- 3. Approval to Accept Schematic Design for the Demolition of the Old Agriculture Barn Project – Chanin Engineering**
- 4. Approval to Accept Schematic Design for the Demolition of Roosevelt Alternative Auditorium – Chanin Engineering**
- 5. Approval to Accept Schematic Design for the K. White Jr. High and R. Cantu Jr. High Scoreboard Project – Chanin Engineering**
- 6. Adoption of Changes to Board Policies as indicated:**
 - a. FNG(LOCAL)- Student and Parent Complaints/Grievances**
 - b. EHB(LOCAL)-Curriculum Design Special Programs**
 - c. EHBAA(LOCAL)- Special Education Identification, Evaluation, and Eligibility**
- 7. Approval of Bids, Proposals and Purchases of \$50,000 and Over**
 - a. Award Purchase Graphing Calculators #162-22-0**
 - b. Award Purchase Athletic Equipment and Supplies #200-22-0**
 - c. Award Purchase Arts and Crafts #246-22-0**
 - d. Award Purchase Theatre Equipment and Supplies #272-22-0**

e. Award Purchase Professional Audio, Photo, Video Equipment and Supplies

#273-22-0

f. Award Purchase Awards, Trophies, Promotional and Apparel Items #300-22-0

g. Award Purchase Tumble Chiller #598-19

h. Award Purchase School and Office Furniture #901-22-0

i. Award Purchase Generator – Annex Network Operations Center

j. Award Purchase HVAC– Annex Network Operations Center

k. Award Purchase Safety and Security Radios

l. Award Purchase Cell Phone Repeaters

m. Award Renewal of Special Education Evaluation and Related Services 223-22-0

n. Award Renewal of Employee Uniforms #320-22-0

o. Award Renewal of Professional Development for Integrating Social-Emotional Techniques

8. Approval of Donations

X. Approval of Minutes

1. September 1, 2021 Special Board of Trustees Meeting

2. September 8, 2021 Regular Board of Trustees Meeting

Motion made by Mrs. Minnie Rodgers to approve the Minutes for both dates. Motion second by Mr. Roy Vela. Motion passed unanimously. Vote 7-0

XI. Executive Session

President Zamora called the Board into Executive Session at 8:20 p.m. and back into Open Session at 9:35 p.m.

1. Private Consultation with Board Attorney (Texas Gov't Code §551.071)

2. Deliberate the Appointment, Employment, Evaluation, Reassignment, Duties, Discipline, or Dismissal of a Public Officer or Employee or to Hear a Complaint or Charge Against an Officer or Employee (Texas Gov't Code §551.074)

XII. Action, if Necessary, on Matters Discussed in Executive Session

Item VIII. Discussion and Possible Action

Recommendation and Approval for the Selection for:

a. Computer Programmer/Analyst

Dr. Perez stated that Administration recommended Andrew Silva for the position of Computer Programmer/Analyst. Motion made by Mrs. Betty Mendoza to approve. Motion second by Mr. Roy Vela. Motion passed unanimously. Vote 7-0

b. ESSER II, Bryan Elementary School Counselor

Dr. Perez stated that Administration recommended Karina Gaona for the position of ESSER II, Bryan Elementary School Counselor. Motion made by Mr. Juan Gonzalez to approve. Motion second by Mrs. Petra Ramirez. Motion passed unanimously. Vote 7-0

XIII. Board of Trustees Information Items

1. Personnel Employments, Resignations, Transfers and Compensation Changes

2. 2022 – 2023 Budget Calendar

3. Financial Reports for the Months of September and October 2021

a. General Fund and Debt Service

b. Self-Funded Health Insurance Fund

4. Tax Levy Adjustments for the Month of October 2021

5. Cash Disbursements for the Month of October 2021

6. Internal Auditor's Quarterly Report for July 1, 2021 through September 30, 2021

XIV. Important Dates to Remember

1. December 20-31, 2021 Winter Break

2. Staff returns January 3, 2022 - Workday January 4, 2022 - Staff Development

Dr. Carol G. Perez stated we'll have our virtual convocation. Also, on that day, we are going to have two days of training for our campus principals. The first day is the Principles themselves with the Breakthrough Coach and the intention of the program is really more organizational skills to allow campus Principals to set aside, two days to be in classrooms. I've gone through that training several times and now they've even made it even better in the past it was just the two days. One day, you go by yourself the second day, you bring your secretary with you and they train you so you and the secretary get organized to be able to free campus principal to be in classrooms, at least two days out of the week and be more efficient with time management and also how to schedule parent meetings and staff meetings. It's totally a huge Paradigm Shift where your secretary handles your calendar. There are a lot of strategies now they added another component. They have ongoing training and support.

3. Students return, Wednesday, January 5, 2022

XV. Adjournment

Motion made by Mrs. Petra Ramirez that the meeting is adjourned. Motion seconded by Mr. Juan Gonzalez passed unanimously. Vote 7-0.

President Zamora adjourned by 9:41 p.m.

Jerry Zamora, President
Mission CISD Board of Trustees

ATTEST:

Roy Vela, Secretary
Mission CISD Board of Trustees



Mission Consolidated Independent School District

- 1201 Bryce Drive • Mission, Texas 78572
- Telephone (956) 323-5505 • Fax (956) 323-5634
- Website: www.mcisd.net

Board of Trustees Minutes

The Board of Trustees of the Mission Consolidated Independent School District held a **Special Meeting on Wednesday, January 5, 2022, scheduled to begin at 6:30 PM** in the **Mission CISD Annex, 925 E. Business HWY. 83, Mission, Tx 78572.**

I. Call to Order and Establish Quorum

President Jerry Zamora called the meeting to order at 6:38 p.m. The meeting was properly posted; a quorum was present. Board Members present besides Jerry Zamora were Petra B. Ramirez, Iris Iglesias, Juan Gonzalez, Minnie Rodgers, Roy Vela (joined remotely), Betty Mendoza, and Dr. Carol G. Perez, Superintendent of Schools.

II. Pledge of Allegiance and Moment of Silence

1. U. S. Flag and Texas Flag

Mr. Jerry Zamora led in the Pledge of Allegiance and he also asked for a moment of silence.

III. Comments from the Public

None

IV. Public Comment(s) on Specific Agenda Item(s)

None

V. Superintendent's Updates and Recognitions

Dr. Carol G. Perez, Superintendent, informed the Board of the following and stated: We have an update on the Farmers Project and the Early College High School portables and we want to take the opportunity to thank everyone that's been involved from maintenance, operations, even our finance department, and everyone that has been contributing. These are beautiful portables that are needed at Early College High School and they are going to be utilized for science for health science and also for our robotics. As you are aware, we needed to expand and they've accepted more students. Therefore, we needed to set up these labs over at Early College High School. The students are excited. They're going to have a place where they can build their robots and maneuver them just like the other High Schools, so we're very excited and as you can see, a lot of funding was saved because our maintenance crew, was able to remodel those portables and these portables came from different places mostly the High School over at Mission High School and they did a beautiful job with the ramps to make sure that they're all ADA Compliant. It's a total of four classrooms, but three buildings.

Update on Veterans Memorial High School Horticulture Classes. This is part of the Farmers Program. Here you can see the students and they are harvesting their vegetables. These were fall-winter vegetables, a lot of greens. We are very proud of what they grew. It's fresh produce. Not only, are they utilizing them for culinary arts but the students themselves taste them and make salads. The staff had a meeting today. They were able to contribute and share with the community through the City of Mission

Food Pantry. This was very exciting, not only for the staff, but the students and they were able to take those fresh vegetables to the pantry.

Last Saturday we had a meeting with our Teachers from Mission High School, VMHS, the head of the Hunger Relief Program from Baylor University, Dr. Elaine Hernandez. She also does a lot of work with the Red Cross and she is a Rotarian. So rotary, as you are aware, is supporting us with a grant and one of the other programs that are going to be expanding is the fact that our teachers and students are going to be doing a lot of community service in teaching grandparents how to grow vegetables in their backyards. This is one way that they are making an impact and changing the world to end Hunger with our elderly as well and in our community. So, we're very excited about everything that they're doing with the FARMERS program and now that we're back. The portables for the FARMERS Program will continue because we already have portables over there and I know we were waiting for some permits. We are going to be installing the septic tank. That permit already came through. Now the only thing that is pending is the permit from TXDOT. We are also working with the Sharyland Water District on providing a water meter to that location. The staff is just so excited and they said, you know, last year at this time of the year when we showed them the Citrus Grove and just threw out a challenge. Can we come up with some innovative classes? The staff stepped up to the plate and within a couple of weeks, there were teaching this. And now what they're saying is that some of the other school districts that already had a farm-to-school program are in awe at the fact that we have 21 out of 23 campuses already on board. We're just working on two more campuses and this initiative is from Pre-k. through 12th grade and now we have partnered with the university with different entities as well and even some of the private industries with Citrus are wanting to partner with us. It's grown and you as Board Members were able to taste the fruit, which was those wonderful oranges. We were able to send out several bags to every campus so, that the students themselves could taste them. We sent it to every single campus and our Community Partners as well. Now, in February, we're going to be harvesting thirteen acres of grapefruit. So that's exciting. We will continue to spread the wealth, provide some to our students, our classes, and our Community Partners, and of course to our Board. Our Culinary Arts students will be making their grapefruit pies. We are excited about that. The majority of the fruit will also be sold and the proceeds are to continue to maintain the orchards. It was a total team effort to put all those bags of oranges. We also wanted to make sure that the first Rotarian that donated the first \$10,000.00 also received a few bags of oranges. We had them send us the address because not only did he provide the first \$10,000.00 he also provided the last \$10,000.00 and this is a person we didn't even know. Just because he read about the project and what it's doing for our Community. So, we're very grateful for that.

The second item is the Breakthrough Coach Professional Development sessions on Monday and Tuesday we went virtual because of the conditions of the pandemic. So, our Principals and Executive Leadership Team attended the first day, and on the second day, we had our secretary join each of their Executive Leaders. The goal of the Breakthrough Coach is to provide us with organizational tools so that we can stay focused on student achievement and empower our secretaries to take control of our calendars and make sure that they move us towards the classrooms. Each campus principal's secretary will be able to set two days of coaching and those two days will be spent in classrooms and hallways observing, coaching, and conferencing with teachers out in the facilities. The same thing with Central Office. We will be doing that with our campuses with our facilities and then we will have our office days where we have, you know, either scheduled meetings or parent conferences, staff conferences, and so forth. So, this particular training empowers our secretaries. The example used in the training is if you have seen the West Wing or any type of TV series where you see the president, who runs the office, or the White House, it's the secretary. The secretary maneuvers the president, or the executive, or the governor, where to go. Why? because they have the schedule and they sat down and they worked on the schedule. So basically, it's a system. It's an organizational system so that we will be able to pay attention where we need to. It's about every day having a meeting with our secretary where we look at our agenda for the day, what needs to be signed, what is to go out, what came in, and so forth and then executing it and you know that planning for the week planning for the day. I've gone through this training in various other capacities. This training has evolved more because in the past when I've gone through this type of training, it's just been one session. Now, it's ongoing. They provide ongoing professional development virtually because they've learned that it takes two to three years to master the program. So, the objective is to be where we are needed with our staff.

Item number three: The Citrus Fiesta Parade will be held on Saturday, January 29th at 2:00 p.m. It is the 90th Diamond Anniversary Celebration. The location will be North Conway and a two-mile line and we will be sending reminders. We will have vehicles for the Board and the Executive Leadership Team.

Also, TASB just sent us a meeting notice for The, 2022 TASB Grassroots Meeting schedule. They're going to be scheduling a meeting at every Region Center to invite all of our Board of Trustees, and the superintendent to attend either in person or remotely so that we can give input for the next Legislative Advisory Council and the meetings will be free. It will include continuing education credit and if we attend in-person dinner will be provided at no cost because we are part of TASB and Region One it will be held Thursday, January 27th from 6 to 8 p.m. at the Region One Educational Service Center. We will send you a reminder.

Board members that would like to attend we will need to register you. So, Cindy and I will be sending reminders to those of you that are available.

VI. Discussion and Possible Action

1. Consideration and Approval of Change Order(s) for the Tom Landry Stadium Repairs Project

Mr. Ricardo Rivera, Assistant Superintendent for Operations, stated at the last Regular Board of Trustees Meeting R. Hinojosa Structural Engineering and RG Enterprises LLC presented a status report on the project. As you know, they've been presenting every month at the Board Workshop and Board Meetings. We just sent them a certified letter, letter saying that the District had concerns about the lack of movement and progress at the Tom Landry Stadium. They came as we know and they presented it and we asked them at that time to no longer try to soften the status on what's going on they needed to be transparent and let us know exactly what the status is if there were delays why is there a delay, and what is the timeline as we heard at the presentation.

There were some delays in the work because there were proposals that were being submitted going back and forth between our engineer and our general contractor and they needed responses at that meeting. They asked if we could expedite some of our meetings and Mr. Zamora, the Board, Dr. Perez, and Administration said, of course, anything it will take to move this project forward. We will meet as needed. And thus, we are here this evening for a special board meeting to address some of these items during this break that was to work on some proposals and there were six that were mentioned. They were supposed to work on the pricing and the timing to present, we received most of them today. However, there are not in the form that we are required to present, which is the G701-217 which is for change orders that specifically states the exact amount of the change order. We have not received that yet. What we did receive is just proposals with some numbers. We have Mr. Albert Trevino from Rick Hinojosa Structural Engineering, we have Rene Garza from RG Enterprises LLC to present each one of these seven, one by one. We've asked them to be very specific on what that proposal entails and what the cost is and the approximate number of days it will take. We need to know exactly what this is. We need to know on each item if this is code, a code requirement and if it's not why is that price. And we need to have an accurate cost of what it takes. If there are different options. We need to know these options.

As you well know, the cost for these seven proposals is extremely high and legally the contract is for a million \$124,000,855.00 legally we can only approve change orders at 25% of the contract. Please be aware of that when you hear these numbers. Also, we need to know for example, if there is anything on these proposed changes, the original scope of work, and the contract. And if it does offset or delete any of the original contracts, we need to receive credit for that. For example, if the original contract had a pier that they had to break 2 by 2 sections and pour 2 yards of concrete, but now they have to break for square feet and add six yards of concrete. They need to give us credit for the original scope of work. They can't just charge us the complete because that is already included in that. So, they need to let us know if it deleted or offset anything on the original contract. We need to know what credit is going to be, given back to the District. This was communicated to both parties this afternoon, so they should and need to let us know this information because again, we cannot exceed 25% of the contract for change orders.

Mr. Alberto Trevino stated I'm here to present and explain several proposal requests for the Tom Landry Stadium. For your information, so we can be clear. A proposal request is used to obtain price quotations required in the negotiation of change orders. A proposal request is not a change order or a directive to proceed with the work. It is simply a request to the contractor for information related to a proposed change in the Construction Contract or The Tom Landry Stadium project. During the day I email the staff that is in our group of Mission CISD stating that we did not feel comfortable coming and presenting a change order. When we could not justify the cost and time of the proposal request. So, we're not here to introduce a change order because again, as I mentioned we do not feel comfortable and we would not be able to justify the cost and time that the contractor is requesting. Today we did the cost proposal from the contractor and I was not able and did not have the time to meet with a Contractor. Mr. Rene Garcia did call me. And I said, at this moment, I can't meet with you because I'm trying to prepare for tonight's meeting. With that let me continue again. You know, as I mentioned in previous Workshop Meetings. The project is going through a slow construction process. At this time due to additional existing non-compliant and conflict in items being encountered. These issues are prompted us to issue several proposal requests to the contractor. A couple of items that have been encountered are the following electrical conduit along a pier that needs to be repaired or abandoned from the project. We had previously issued proposal request number two to the Contractor to expose its conduits, which the Board approved during the November School Board Meeting. The contractor has excavated the areas affected, and we have noticed that several piers along that string line are affected. On December 15, 2021, Missions CISD staff sent us an email dated April 28, 2017, for Mr. Robert Rodriguez requesting the additional spare conduits between the 10-yard line to the 10-yard line from the original contractor. The following two items are to be addressed this item and we have two items we had asked Missions CISD Staff which do you want to pick? We're introducing two because they mentioned presenting it to the board, to see which route they would take. Again, we do not know at this moment if those conduits that are, are the ones that are being referenced in an email between Mission CISD and Mr. Eli Alvarado, but there is a bundle of conduits there. So, with that said, not only if there is, those are the spears or not? They appear to be but we do not know we present your proposal request. Number three proposal request number three. This proposed to remove three feet in length of the electrical, conduit at piers, B7, B8 B9, B10, B11, and B12 that are interfering with

the pier repair. What we ask is to remove three feet in length of the electrical conduits at Piers B7, B8, B9, B10, B11, and B12. Also, this proposal request was issued if proposal request number four is not approved. In our opinion, the constant time extension is not acceptable for that price. Now here, this proposal is, I know I put it before number four, but number four is if the School District the Board will prefer for the contractor to do more excavation and see what those electrical conduits are for. So that means they have to excavate at least from the 10-yard line to a 10-yard line per the email that was sent on April 28, 2017, from Mission CISD to the Architect and the Contractor at that time. If that is not proof or you would say, you know, we don't know what those conduits are and the school district decides I don't think we need them if there's nothing there. We will recommend abandoning them and going with proposal request number three.

Dr. Perez stated we are going to table this item for our next Special Board Meeting next Wednesday.

VII. Important Dates to Remember

- 1. January 12, 2022, Board of Trustees Workshop**
- 2. January 19, 2022, Regular Board of Trustees Meeting**

Dr. Perez stated we are going to add a Special Board Meeting to continue with the Change Order for The Tom Landry Stadium.

VIII. Action, if Necessary, on Matters Discussed in Executive Session

- 1. Private Consultation with Board Attorney (Texas Gov't Code §551.071)**
- 2. Deliberate the Appointment, Employment, Evaluation, Reassignment, Duties, Discipline, or Dismissal of a Public Officer or Employee or to Hear a Complaint or Charge Against an Officer or Employee (Texas Gov't Code §551.074)**

President Zamora advised the Board will now go into Executive Session at 8:17 p.m.

Vice President Mendoza advised it is 9:26 p.m. returning from Executive Session. Ms. Mendoza asked if there were any other discussions? Do I hear a motion to adjourn the meeting?

IX. Adjournment

Motion made by Mrs. Petra Ramirez that the meeting is adjourned. Motion seconded by Ms. Minnie Rodgers. Motion passed.
Vote 6-0

Vice President, Mendoza adjourned the meeting at 9:26 p.m.

Gerardo Zamora, President
Mission CISD Board of Trustees

ATTEST:

Roy Vela, Secretary
Mission CISD Board of Trustees



Mission Consolidated Independent School District

- 1201 Bryce Drive • Mission, Texas 78572
- Telephone (956) 323-5505 • Fax (956) 323-5634
- Website: www.mcisd.net

Board of Trustees Minutes

The Board of Trustees of the Mission Consolidated Independent School District held a **Special Meeting** on **Wednesday, January 12, 2022, scheduled to begin at 7:30 PM** in the **Mission CISD Annex, 925 E. Business HWY. 83, Mission, Tx 78572.**

I. Call to Order and Establish Quorum

President Jerry Zamora called the meeting to order at 6:34 p.m. The meeting was properly posted; a quorum was present. Board Members present besides Jerry Zamora were Petra B. Ramirez, Iris Iglesias, Juan M. Gonzalez (joined remotely), Roy Vela (joined remotely), Minnie Rodgers, Veronica R. Mendoza, and Dr. Carol G. Perez, Superintendent of Schools.

II. Pledge of Allegiance and Moment of Silence

1. U. S. Flag and Texas Flag –

Mr. Zamora led in the Pledge of Allegiance and he also asked for a moment of silence.

III. Comments from the Public

None

IV. Public Comment(s) on Specific Agenda Items(s)

None

V. Superintendent's Updates and Recognitions

Dr. Carol G. Perez, Superintendent, informed the Board of the following and stated: I had a meeting with the Texas Education Agency, Commissioner Morath last Friday, and he just wanted to give us some updates and some recommendations on, of course, instruction and also continued the guidance with COVID-19. He talked about the fact that we have to have all hands on deck, especially with the pandemic and as staff is out which we had already implemented, and I had told the staff we are not going to worry about what account we're paying individuals, whether it's a migrant account, whether it's a federal account, we must have individuals in classrooms. We will look at it and if we have to make changes in terms of requests of funding to local funding will do whatever it takes. The Commissioner advised us that he had already secured a waiver from the Federal Government to allow us to utilize our support staff as needed because even though we have over 300 substitutes, I believe we trained an additional 40 last Friday. They also do get sick or also have other things to attend to at times and may not be available. As you are aware that the Center for Disease Control, had some recommendations in terms of quarantine for five days. The research is showing now that transmission has evolved and the time has shrunk, therefore, now, they're recommending five days of quarantine. We as a school district, have remained very cautious and continued all this time throughout the pandemic, both years with 10 days. Now based on the new evidence, the new research we wanted to make it win-win and kind of not make drastic changes, but be very cautious. The commissioner recommended that we dialogue about what would be best for our school district and he made it very clear that CDC

Center for Disease Control cannot direct only recommend. It is not law. Also, the Commissioners recommendations from a Texas Education Agency is not law. It's not policy. They are recommendations, so he directed Superintendents to come up with Administrative Procedures and Protocols. That would be in the best interest of our children, our staff, and our community based on the conditions of the pandemic, therefore, with consultation, with authorities, also with our COVID Team, our Executive Leadership Team, and campus principles we were able to provide a better understanding of what was happening and therefore, the quarantine has been updated to seven days for staff members, of course, it's going to depend whether individuals are vaccinated. How many times, are they going to be asked to test and so forth. Also, it just depends if the employee is COVID positive or not, if they have someone in the household, so there are different scenarios as to on which days they're going to be asked to test and for that, we are following CDC Guidelines, but for positive cases, the quarantine update is seven days. The question is, what about students? Students will remain with ten days because it is a requirement from the Texas Department of State Health Services, which reads COVID-19 School Readmission Criteria Coronavirus disease 2019, commonly referred to as COVID-19 is a disease requiring exclusion from school and there is an Administrative Code 97.7. This is the law. A school Administrator shall exclude from attendance any child having or suspected of having COVID-19 exclusion shall continue until the Readmission Criteria for the conditions are met. The Readmission Criteria for COVID-19, are as follows if symptomatic exclude until at least 10 days have passed since symptom onset and fever-free. So, since the beginning of the symptoms, 10 days for students, they must be fever-free and other symptoms have improved. Children who test positive for COVID-19, but do not have any symptoms must still stay home until at least 10 days after the day they were tested and they must be fever free for 24 hours without the use of fever suppressing medications. Fever is a temperature of 100 degrees Fahrenheit or 37.8 degrees Celsius or higher. If this gets updated and it probably will with new research coming up, but until the Department of State Health Services directs us differently through their Administrative Code, then we will make adjustments.

We received a donation of masks from Mission Regional Medical Center and they donated 1,000 k95 masks to Mission CISD. and those are the aqua masks, we are very grateful for that donation because the research from the CDC states that if an individual is wearing a k95 mask and is COVID positive, the person right next to me, let's say, I am positive. I'm wearing like an N95 and an individual next to me is wearing a k95 mask it will take 25 hours for that individual to get the disease, so these masks are invaluable to us. We want to thank Mission Regional Medical Center.

Picnic tables as you are aware, it was recommended that we purchase picnic tables for our schools so that our children would have the opportunity to eat outdoors which the CDC recommends. Some of these tables have been arriving. I do have some pictures that the principal from Alton Elementary sent to us and they were aesthetic because with these picnic tables, not only will the children be able to utilize them to eat outdoors. But also, teachers can take the children, outdoors, and conduct lessons and be in the fresh air, of course, you know, as the weather conditions allow. These picnic tables have been arriving and we ordered plenty of picnic tables for all of the campuses. Campus principals were asked how many they need and then based on the recommendations, and the funding that had been allocated for that the picnic tables were ordered these are really nice picnic tables because they are steel but they're covered with plastic that's very durable.

We did send out letters to parents and to our staff, even last year when the CDC told us that the virus dies within 24 hours. Also, the fact that we didn't have to e-mist daily because the solution continues to disinfect, we made a commitment that we would be disinfecting our classrooms, our offices, and our facilities, on a daily basis. So our facilities are disinfected on a daily basis and even during the day we have continued with all of the same protocols with the use of masks, wearing your mask washing our hands utilizing hand sanitizer, and watching our physical distancing also in coming back we had planned two days of professional development for our Campus Principles and our Executive Leadership Team which we decided based on the conditions to do it virtually the same thing with the teacher in-service sessions we went ahead and did those virtually. We made sure that we communicated with every campus principal that our meetings should continue to be conducted virtually any type of student activity plans continue to be submitted to Mr. Castaneda that is in charge of security and the executive directors and a plan of action detailed plan of action is submitted in following all of the protocols and guidelines and if they don't meet the plan is sent back and in some instances, decisions have been made, for example, some of the UIL competitions, have been moved to virtual as well. We are completely vigilant even today we had a Superintendent Zoom call with our Hidalgo County Judge, Dr. Melendez, and Eddie Olivares we had a very good discussion. They wanted to know how things are going what else can they do to support us and so forth. They are continuing with recommendations on the best practices, wearing a mask watching your distance, and also washing our hands frequently or disinfecting. Mr. Eddie Olivares, just continued to sing the praises for our nurses, because they have really done a great job. One of the things that I think we should be very proud of the fact is that there was a huge echo with other Superintendent stating that they were lacking tests for students and staff and I was able to say, we have plenty of tests, why we have a stack that, you know, we planned and we try to stay ahead of the curve as possible so our orders were put in with plenty of time because it takes at least a couple of months to process. Last week, we received our shipment of 10,000 testing strips. We were also one of the very first school districts in the state to be awarded the grant with a management company that goes around to our schools and brings personnel to test personally with PCR tests and there's a 24-hour turnaround. One of the requests that I did put into the Judge is the fact that our curative labs, they are running out of tests. So, we do need assistance with that, even over the holidays we

pass around there were 30 to 50 people in line all day long, which the community really needs. When we came back from the holidays we were told that they were getting a shipment from Laredo. Mr. Verley and Mr. Castaneda, they've been making announcements sending information out to the community that usually registration opens at 7:30 p.m. at night, people must register. As a matter of fact, this morning at about 7:30-7:45 driving in, there were people already in line waiting and there was a vehicle that came over and asked me, you know, at what time are they going to open and I told him, you must register. They're not open yet, they will open but you must be registered. So, please go online and do that. All of our protocols are there, they're tight, and there's a lot of monitoring going on in our schools. Some of the discussions were that our schools are very safe places to be because of the fact that we're very cautious in terms of all the protocols that we have in place. Thank you.

VI. Presentation(s) to the Board of Trustees

1. Award of Contract for Delinquent Tax Attorney and District's Taxable Property Value Audit #103-22-1

Mr. Joel Garcia, Assistant Superintendent for Finance, stated today we have a presentation for the Delinquent Tax Attorney and District's Taxable Property Value. So, let me provide some background, the agreement for The Delinquent Tax Collection Service expired on January 11, 2022, and the property value study expires on January 11, 2023. What we're trying to accomplish is to align the property values study along with the delinquent tax collection. The district is seeking a firm to collect property taxes out to the district. In the package you received today you'll see that there is a ranking sheet. We can rank the proposals. Similar to other rankings that we've done number one would be for the first choice. If you use number two that's for your second choice meaning that the lowest score is the highest ranking, so we'll do this after the presentations. If you could kindly just sign and date the form.

Linebarger Goggan Blair & Sampson, LLP representative presented. The second presentation was presented by a representative of Perdue Brandon Fielder Collins & Mott LLP.

VII. Discussion and Possible Action

1. Award of Contract for Delinquent Tax Attorney and District's Taxable Property Value Audit #103-22-1

Dr. Perez stated I believe you already have your ranking sheets, Board Members As directed by the Board, we have the ranking sheets there are two companies. The Board is to vote on a number one, and a number two or rank not vote, but ranked based on the packet that you did receive and those that are virtual, I believe that Mr. Garcia emailed you the ranking form, therefore, you will complete it and email it to Mr. Garcia and you may also text it for efficiency, but he will need it emailed. Once the ranking is completed Mr. Garcia will collect them and tally and then give me the information.

Mr. Garcia stated that the lowest score is the one that is awarded.

Dr. Perez stated the company with the lowest score, as Mr. Garcia mentioned is to be awarded is Linebarger Goggan Blair & Sampson, LLP and that is based on the Board ranking.

Mr. Garcia stated that based on the evaluation Administration would like to recommend Linebarger Goggan Blair & Sampson, LLP.

A motion was made by Mrs. Petra Ramirez for approval. Motion second by Mr. Roy Vela. Motion passed unanimously.
Vote 7-0

2. Consideration and Approval of Change Order(s) for the Tom Landry Stadium Repairs Project

Mr. Ricardo Rivera Assistant Superintendent for Operations stated that as has been presented in the past few meetings there are some change orders that have been asked to be expedited. So, thank you very much for the Special Meeting, we have several change orders. That will be presented by Mr. Rick Hinojosa and Mr. Albert Trevino from Rick Hinojosa Structural Engineering. We also have present Mr. Rene Garza and Mr. Manuel Lee Leal from RG Enterprises LLC to make these presentations. Copies of the change orders were passed out before you. I do ask that you not only look at the costs but also look at the number of days that they're requesting and the possible substantial completion dates that are noted. Again, legally we can only go 25% of change orders on the total construction cost which is \$1,024,855.00. Change orders were presented for the Tom Landry Stadium Project.

Mr. David Hansen attorney stated if you could please contact my office with the full scope and pricing as soon as possible. That way we can prepare a final change order for the Board to consider and possibly approve at the next Board Meeting officially.

Dr. Perez asked Mr. Hansen were you going to address the Board in Executive Session?

Mr. Hansen responded that at this time there isn't anything on this particular Agenda unless the Board has any legal questions about the construction. There is nothing to address in a close session.

Dr. Perez and the Board members responded with no questions. Thank you

VIII. Executive Session

- 1. Private Consultation with Board Attorney (Texas Gov't Code §551.071)**
- 2. Deliberate the Appointment, Employment, Evaluation, Reassignment, Duties, Discipline, or Dismissal of a Public Officer or Employee or to Hear a Complaint or Charge Against an Officer or Employee (Texas Gov't Code §551.074)**

IX. Action, if Necessary, on Matters Discussed in Executive Session

X. Important Dates to Remember

- 1. January 19, 2022, Regular Board of Trustees Meeting at 6:30 p.m.**

XI. Adjournment

Motion made by Mrs. Petra Ramirez that the meeting is adjourned. Motion seconded by Mr. Roy Vela. Motion passed.
Vote 7-0

Vice President, Mendoza adjourned the meeting at 8:10 p.m.

Gerardo Zamora, President
Mission CISD Board of Trustees

ATTEST:

Roy Vela, Secretary
Mission CISD Board of Trustees



Mission Consolidated Independent School District
• 1201 Bryce Drive • Mission, Texas 78572
• Telephone (956) 323-5505 • Fax (956) 323-5634
• Website: www.mcisd.net

Board of Trustees Minutes

The Board of Trustees of the Mission Consolidated Independent School District held a **Regular Meeting on Wednesday, January 19, 2022, at 6:30 PM** in the **Mission CISD Annex, 925 E. Business HWY. 83, Mission, Tx 78572.**

I. Call Meeting to Order and Establish Quorum

President Jerry Zamora called the meeting to order at 6:36 p.m. The meeting was properly posted; a quorum was present. Board Members present besides Jerry Zamora were Petra B. Ramirez, Iris Iglesias (joined remotely), Juan M. Gonzalez, Roy Vela (joined remotely), Veronica R. Mendoza, and Dr. Carol G. Perez, Superintendent of Schools.

II. Pledge of Allegiance and Moment of Silence

Mr. Jerry Zamora led in the Pledge of Allegiance and he also asked for a Moment of Silence.

III. Comments from the Public

None

IV. Public Comment(s) on a Specific Agenda Item(s)

None

V. Superintendent's Updates and Recognitions

Dr. Carol G. Perez, Superintendent informed the Board of the following: This month is Board Recognition, and it is celebrated each January the Texas Association for School Boards always has a theme and for this school year it's rising above our Mission CISD vision would not be possible without the unending and diligent work of its dedicated Board of Trustees that are being honored tonight as they support us to rise above expectations School Board month recognition is the time of the year, where we take a few minutes to recognize the many accomplishments of our Board of Trustees. We'd like to celebrate that our Region One Education Service Center named the Mission CISD Board as Board of the year. Not only that the Texas Association for Supervisors Administrators of Texas also named the Mission CISD Board as one of the top five Awards in the State. They have made many contributions as they work diligently year-round and they are very committed. Our board members are local volunteers who are elected by their constituents and receive no compensation for all of the work they do because they are public servants. Our Board Members have spent countless hours attending workshops meetings, developing policies, and making tough decisions. Especially during these complex times in our educational world and the decisions that they make, not only affect our children, our staff, our community on educational achievements, but also social issues that are impacting us every single day. Tonight, I have the distinct pleasure of thanking our Board Members on behalf of our students, parents, staff, and the community as a whole for their service and invaluable contribution to our children's education. So, tonight we say thank you Board of Trustees.

Dr. Perez read Governor Abbott's proclamation. It reads as follows: From the State of Texas office of the Governor in Texas, we place immense value on our youths. We protect them, guide them, and prepare them for a successful future because we know they are the next generation of leaders of our State and Nation. We also understand the key role education plays in young people's lives. School districts across Texas have continued to dedicate time and resources to ensure Texas students receive a rigorous and well-rounded education that will serve as the foundation upon which their dreams will be turned into reality. School Boards are an integral fabric, woven into the tapestry of the Texas Education System. They work with parents, educational professionals and community members

Mission CISD Board of Trustees Minutes
January 19, 2022
Page 1 of 6

to create successful learning environments for our students, our school boards continue to be instrumental as they tackle new challenges for Texas Public Schools and serve the ever-evolving needs of our students. Texans know they can count on the school board members along with other dedicated School administration, officials to create opportunities to discuss, important issues, develop innovative solutions and Empower Educators while remaining focused on their student's Futures. At this time, I encourage all Texans to recognize and honor the work and successes of our School Board Members, who play an important role in the education of students across the state by continuing to support our children's education we will ensure a better and brighter future for the Lone Star State. Therefore, I Greg Abbott Governor of Texas do hereby Proclaim January 2022 to be School Board recognition month in Texas and urge the appropriate recognition whereof in official recognition, whereof I hereby affix my signature, this 8th day of November 20, 2021, Governor Abbott, Governor of Texas.

Dr. Perez highlighted some campus achievements at Mission High School. She stated we are delighted to recognize that our CTE students from BPA are being recognized in competition and moving on to state in the areas of intermediate word processing, fundamental spreadsheet applications, fundamental word processing, health administration procedures, personal financial management, advanced spreadsheet, administrative support team. Also, their Deca Chapter did an outstanding job at the competition. Our Mission High School Cheerleaders also competed in the UIL State Spirit competition and they went to Fort Worth last weekend to compete. And this year was quite successful, they competed in the largest division of all 6A and literally missed finals by 1.5 points. For Veterans Memorial High School highlights they also participated in BPA 13 DECA students, also advancing to state in the areas of principles of finance, project management career development, hospitality tourism, and professional selling, sports entertainment management, hospitality, and tourism, professional selling, project management, career development project management, community awareness, principles of finance, and six BPA students are also advancing to state in business Professionals of America.

Dr. Perez informed the Board we have also been working with our campuses last week and this week we have been working with campus data virtual visits in which the Executive Leadership Team and me, especially with curriculum and instruction we've been visiting virtually with the campus administrators and we're looking at our 2022 accountability goals, as you are aware. They did present their campus Improvement plans. And in the middle of the year, what we do is touch base with them to see the areas of strength, the areas of need, and how we can support them as a school district. So, we also were able to share a calculator so that they're able to see how many more students do they need, especially in special populations, whether it's English language development students, special education students, children with dyslexia 504, regular ed students and how many students or which students are the students that need much more assistance, which students are doing great. So, we share different software. Also, they reported on House, Bill 4545, which requires students that didn't do well last year they receive so many hours of instructional support, which are tutorials during the week after school before school. We also talked about increasing daily attendance, remote, conferencing virtual instruction, and anything else that the campus may need support.

We are happy to announce that we are already receiving additional COVID-19 testing. And as you are aware through the Texas Education Agency, we did receive a grant where we were able to collaborate with a management company to offer PCR COVID-19 tests at no charge for our staff and our students. I was able to send an email letting everyone know. That service will already be available. We want to thank the City of Mission and especially the Fire Department. They loaned us their mobile unit where the management company will be housed to be able to offer these PCR drive-throughs and the results we can probably get within 24 hours because they are PCRS. We do have plenty of antigen tests in our school district. You are aware that some school districts have had to close because they don't have tests. We are very fortunate that last week as I reported. We did receive 10,000 additional kits, and we had in stock at least almost 3,000. So, we're doing really well. So together will continue to work towards keeping our instructional learning environments and working learning environments as safe as we possibly can. Also, we received a call yesterday from the Texas Education Agency because the president of the United States is providing additional funding to Texas. The gentleman that contacted our school district stated that they wanted to provide additional COVID-19 rapid test antigen tests and the Texas Education Agency was tasked with selecting five school districts in the state we are happy to report that Mission CISD is one of those school districts. And the first question that I ask is, Why Us this is the response. Mission CISD was chosen from a list of Texas School Systems based on the social vulnerability indexed the testing need and current COVID reporting numbers. So please note that our staff is doing a tremendous job to report our daily and weekly counts, to both Hidalgo County and the Texas Education Agency and this is the reason why they were able to see our need and provide these testing kits. So today we have a video that we would like to share this video will be put on our district website possibly tick-tock as well it's about the twelve things or a dozen of things that we are doing in our facilities to maintain a safe learning and working environments.

Dr. Perez informed the Board of other news The Holdsworth District Task Force number two session will be held on Tuesday, February 1st and it's going to be a virtual session as we continue with the development of our Mission CISD Leadership definition. It was scheduled to be in person, but because of current conditions, we are going to go ahead and have it virtually.

In other news, the South Texas Association of Schools that association helps to bring information to South Texas in Region One and Region two for Superintendents. Last year I was appointed as a Board Member of the South Texas Association of Schools this year, which just last week. I was nominated and appointed to become their Treasurer as one of the Superintendents from region two retired, so I was appointed. So of course, I thought, okay. It's a learning experience. So, we'll go ahead and serve and we are getting ready to set up our legislative priorities. We continue to provide information for Region One and Region two. In other news, the Board knows the Executive Leadership Team and our Administrators, since Monday morning. We started looking at weather conditions, especially for Friday. So, we've been very cautious. We've also been listening to everything that's coming our way through news reports through the National Weather Service. As a matter of fact, today at 2:00 p.m. we also had a briefing by Mr. Goldsmith he is the warning coordinator meteorologist from the National Weather Service in Brownsville, and he serves the whole Rio Grande Valley. He keeps us abreast of any new developments through emails constantly. We had a briefing at 2 p.m. In which he was able to share. He slides on the RGV Deep South Texas cold wintry precipitation that is upcoming. Especially Thursday overnight and Friday morning. Therefore, sometime tomorrow before noon we will be making decisions based on the most current information that we have regarding the weather projections and also measuring how is going to be impacting the Friday morning commute. Here in the valley, we are not used to driving in hazardous conditions, even though it seems that it may not reach freezing. However, the wind chill factor will be at freezing temperatures. Therefore, the ice may not stick but at the same time, it may become dangerous. Therefore decisions, as to what will happen on Friday will be made as soon as we possibly have the best information possible because we want to make sure that our parents, our staff, and our community has plenty of time to make preparations whether we cancel classes on Friday or not, now in Terms of students and the school calendar we have enough minutes built into our school calendar, where students would not need to make up the time. However, when it comes to staff, we do not have extra minutes or days therefore we would all have to make up the day. If we do call it a weather day. We've looked at our upcoming calendar. We do have a Holiday in February and two holidays in April Easter holiday, we really don't want to touch those days because we really need for our staff to be able to rest, and refresh and enjoy their families, especially during these times, therefore, the best option and recommendation if we do cancel Friday classes would be to make up the day at the end of the school year, which would be on a Saturday, which is graduation day so that we believe is the best option because anyway, the staff is already going to have a great long vacation. Hopefully during the summer and we don't want to take away the holiday in February and in April. Stay tuned because we want to make the decision as early as possible. Hopefully, by mid-morning before noon. And that will be based on the current conditions available to us.

Dr. Perez thanked Mr. Martin Castaneda for giving us updates on it and stated we're very grateful for all the support. When any need arises in our District he's the first one on the scene, no matter what.

VI. Discussion and Possible Action

1. Award Purchase of Renaissance Learning - Renaissance myON Reader Program for Requesting Campuses

Dr. Sharon Roberts, Deputy Superintendent for Curriculum and Instruction stated the award and purchase of the Renaissance Learning myON Reader Program for campuses that requested it. This is part of the Renaissance reading program, which is our AR program at our campuses. This is the component that has the online library books that students may read, some campuses did request that and the Predators will exceed \$50,000.00 so we do need to bring it before the Board for approval. The campuses that are requesting it are Bryan Elementary, Cavazos Elementary, Escobar/Rios Elementary, Marcell Elementary, Midkiff Elementary, O'Grady Elementary, Salinas Elementary, Waitz Elementary, Alton Memorial Jr. High, K. White Jr. High, Mission Jr. High, and R.Cantu Jr. High. The purchase will be made using BuyBoard inter-local purchase co-op. Using an inter-local purchase co-op complies with purchase requirements of TEC 44.031a(5) and local board policy requiring an approved purchasing method for contracts valued at \$50,000 or more. The total cost would be \$79,488.00 and it would come out of the campus's State and Federal Funds.

A motion was made by Mr. Juan Gonzalez for approval. Motion second by Mrs. Betty Mendoza. Motion passed unanimously. Vote 6-0

2. Consideration and Approval of Administrations Rankings and Enter Into Negotiations in the Order of Ranking for the Field Events for the Middle School Project

Mr. Ricardo Rivera, Assistant Superintendent for Operations stated the first agenda item I have is consideration and approval of the Administration Rankings and Enter Into Negotiations in the Order of Ranking for the Field Events for the Middle School Project. This agenda item was presented at the Board of Trustees workshop on Wednesday, January 12, 2022. Administration presents consideration approval for Administration's Rankings and Enter Into Negotiations in the Order of Ranking for the Field Events for the Middle School Project with Teni-Trak.

A motion was made by Mrs. Betty Mendoza for approval. Motion second by Mr. Juan Gonzalez. Motion passed unanimously.
Vote 6-0

3. Consideration and Approval of Change Order(s) for the Tom Landry Stadium Repairs Project

Dr. Perez, Superintendent stated this item will be moved to Executive Session.

4. Consideration and Possible Action Regarding Substitute Teacher Pay

Ms. Lorena Garcia, Deputy Superintendent for Support Services stated Administration is recommending that the Board of Trustees consider a temporary increase for the substitute rate of pay for the second semester of the 2021-2022 school year.

A motion was made by Mr. Juan Gonzalez for approval. Motion second by Mrs. Iris Iglesias. Motion passed unanimously.
Vote 6-0

5. Consider Superintendent's Evaluation, Contract, and Compensation

Dr. Perez stated this item will be moved over to the next Board Meeting.

VII. Recommendation(s)

- 1. Approval of the Selection for:**
 - a. Leal Elementary Assistant Principal**
 - b. Licensed Specialist in School Psychology**
 - c. Educational Diagnostician in Special Education**

Item was discussed in Executive Session.

Dr. Carol G. Perez stated we only have the Assistant Principal and the Diagnostician position. We are not ready to move forward with the LSSP position.

VIII. Items to Consider: The Board will consider and may act on the following items under a CONSENT AGENDA. Any Trustee may request the removal of an item from the CONSENT AGENDA for individual consideration and action.

Dr. Perez stated Consent Agenda includes from #1 through #7, if the Board would like to move out any item please let us know. They were all discussed in last week's Board Workshop.

Motion made by Mr. Juan Gonzalez that the Board approves the Consent Agenda VIII Items #1 through 7.
Motion second by Mrs. Petra Ramirez. Motion passed unanimously. Vote 6-0

- 1. Approval to Accept Final Completion for the Security Vestibules Project at Alton Memorial Jr. High, K. White Jr. High, Pearson Elementary & Roosevelt Alternative**
- 2. Approval to Accept Final Design for the Child Nutrition Program Walk-in Freezers for Bryan, Marcell and Salinas Elementary Project**
- 3. Approval to Accept Final Design for the K. White Jr. High and R. Cantu Jr. High Scoreboard Project**
- 4. Approval to Accept Substantial Completion for the Canopies and Sidewalks at the Mission High School Special Education 18+ Program**
- 5. Second Reading and Adoption of TASB-Policy Update 118, affecting local policies:**
 - a. CFD(LOCAL) ACCOUNTING: ACTIVITY FUNDS MANAGEMENT**
 - b. CQB(LOCAL) TECHNOLOGY RESOURCES: CYBERSECURITY**
 - c. DFE(LOCAL) TERMINATION OF EMPLOYMENT: RESIGNATION**

- d. **DP(LOCAL) PERSONNEL POSITIONS**
- e. **EHAA(LOCAL) BASIC INSTRUCTIONAL PROGRAM: REQUIRED INSTRUCTION (ALL LEVELS)**
- f. **EHBC(LOCAL) SPECIAL PROGRAMS: COMPENSATORY/ACCELERATED SERVICES**
- g. **EIE(LOCAL) ACADEMIC ACHIEVEMENT: RETENTION AND PROMOTION**
- h. **FDE(LOCAL) ADMISSIONS: SCHOOL SAFETY TRANSFERS**
- i. **FEA(LOCAL) ATTENDANCE: COMPULSORY ATTENDANCE**
- j. **FEC(LOCAL) ATTENDANCE: ATTENDANCE FOR CREDIT**
- k. **FFG(LOCAL) STUDENT WELFARE: CHILD ABUSE AND NEGLECT**
- l. **FL(LOCAL) STUDENT RECORDS**

6. Approval of Order of General Election for May 7, 2022, Mission CISD Board of Trustees Election

7. Approval of Donations

IX. Executive Session

President Zamora called the Board into Executive Session at 7:30 p.m. and back into Open Session at 9:04 p.m.

- 1. **Private Consultation with Board Attorney (Texas Gov't Code §551.071)**
 - 2. **Deliberate the Appointment, Employment, Evaluation, Reassignment, Duties, Discipline, or Dismissal of a Public Officer or Employee or to Hear a Complaint or Charge Against an Officer or Employee (Texas Gov't Code §551.074)**
- X. Action, if Necessary, on Matters Discussed in Executive Session**

VI. Discussion and Possible Action

3. Consideration and Approval of Change Order(s) for the Tom Landry Stadium Repairs Project

Motion made by Mr. Jerry Zamora to authorize the Superintendent to negotiate the Change Order(s) for the Tom Landry Stadium Repairs Project and subject to Board approval. Motion second by Mr. Roy Vela. Motion passed unanimously. Vote 6-0

VII. Recommendation and Approval for the Selection for:

a. Leal Elementary Assistant Principal

Dr. Perez stated that Administration recommended Alicia C. Bazan for the position of Leal Elementary Assistant Principal. Motion made by Mr. Juan Gonzalez to approve. Motion second by Mrs. Petra Ramirez. Motion passed unanimously. 6-0

b. Educational Diagnostician in Special Education

Dr. Perez stated that Administration recommended Cristina Perez for the position of Educational Diagnostician in Special Education. Motion made by Mrs. Betty Mendoza to approve. Motion second by Mr. Roy Vela. Motion passed unanimously. Vote 6-0

XI. Board of Trustees Information Items

- 1. **Personnel Employments, Resignations, Transfers and Compensation Changes**
- 2. **Financial Reports for the Month of November 2021**
 - a. **General Funds and Debt Service**
 - b. **Self-Funded Health Insurance Fund**
- 3. **Tax Levy Adjustments for the Month of November 2021**
- 4. **Disbursements for the Month of November 2021**

XII. Important Dates to Remember

- 1. **February 2, 2022, Board of Trustees Workshop at 6:30 p.m.**

2. February 9, 2022, Regular Board of Trustees Meeting at 6:30 p.m.

XIII. Adjournment

Motion made by Mrs. Petra Ramirez that the meeting is adjourned. Motion seconded by Mr. Juan Gonzalez passed unanimously. Vote 6-0.

President Zamora adjourned by 9:07 p.m.

Jerry Zamora, President
Mission CISD Board of Trustees

ATTEST:

Roy Vela, Secretary
Mission CISD Board of Trustees

SUBJECT: Memorandum of Understanding with Kids U US, Inc. dba Fueling Brains

PRESENTER: Lorena Garcia, Deputy Superintendent for Support Services

BACKGROUND INFORMATION

On December 15, 2021, the Board of Trustees approved the RFP for On-site Before and After School Child Care Services #602- 22-1 with KidsU US, Inc. dba Fueling Brains.

The Fueling Brains before/after-school program is a full-time childcare program that operates before school starts (6:00 am to 7:30 am) and after school ends (3:30 pm to 6:00 pm). The times are adjusted according to each school's schedule. Overlapping periods will be adjusted based on student enrollment, time, length of tasks, and time-lapse between tasks.

Early dismissal days, staff development days, Spring Break, and during the summer, the program will offer additional enrichment programming services.

This program is structured, curriculum-based, and filled with a variety of enrichment activities. Students participate in an assortment of educational, creative, and recreational activities during these enrichment classes. Each week is theme-based, filled with learning, and most of all, engaging! Students will enjoy organized and supervised play with opportunities to interact with their peers in a safe, fun, and stimulating environment. These activities include arts (performing & visual)-n-crafts, LEGO creations, number sense, science experiments, character-building lessons, and many other hands-on activities.

Tutorial services are provided and serve as a learning extension of the classroom. The tutorial services are TEKS-based and are provided by staff who are knowledgeable in core content areas (ELAR, Math, Science, and Social Studies). Additional tutorials are provided in elective class areas.

ADMINISTRATIVE CONSIDERATIONS

Fueling Brains is proposing to intermediate between TEA and Texas Childcare solutions for young children to receive complete wrap-around services from 6:30 am to 6:00 pm.

Unlike traditional before/after-school programs Fueling Brains will participate in leadership and instruction during the entire school day.

Their licensed childcare directors will coordinate with Mission CISD teachers, assistants, and childcare staff to provide a comprehensive solution to MCISD students and their families. These students will be enrolled in the Early Learning Academy Powered by Fueling Brains.

The Early Learning Academy Powered by Fueling Brains will comply with P3 objectives to create a win-win for all stakeholders. P3 refers to early learning partnerships that are formal collaborations between school districts and private early learning centers or Head Start centers. The resulting partnership allows them to dual enroll children and provide prekindergarten and/or additional comprehensive, wrap-around services.

With this initiative, the primary focus for the 2022-2023 School Year is to increase enrollment in the PreK 3 and PreK 4 classrooms. By creating a consistent magnet program for all 3- and 4-year-olds, the Early Learning Academy Powered by Fueling Brains, across the 14 campuses, fully operated by Fueling Brains, will provide fully ready Kindergarten- (5-year-old) children into the Mission CISD feeder patterns.

The 3- and 4-year-olds will be dually enrolled with the district and Fueling Brains Program. The district understands the program will be Operated by Kids U US Inc. (Fueling Brains, DBA) and/or other designated assignees who will be responsible for the implementation and full operation of the program.

Typically, P3 partnerships are supported via the TWC in licensed childcare facilities. We understand not all 3- and 4-year-olds will qualify under TWC guidelines, therefore Fueling Brains will subsidize up to 20% of the total allocated funding that should be received for students through TWC. All parents will need to make an effort, through the registrar to enroll in TWC. Fueling Brains will guide parents through the enrollment and application process as it pertains to Texas Workforce. The program will serve under the Texas Childcare Licensing Regulations as provided by the Human and Health Services Department and the state of Texas.

Mission CISD will provide staffing and facilities, and Fueling Brains will fund staffing outside of regular school hours including, but not limited to, Director Support and Registrar Support. The Director and Registrar (and additional staff provided) will report directly to the Fueling Brains.

To increase enrollment Fueling Brains will schedule its marketing and branding campaigns throughout the district.

Fueling Brains will also develop parents' knowledge related to the importance of executive function in their child's brain for the parent to effectively interpret their child's brain assessment report and then implement associated Fueling Brains home-based activities. Additionally, relevant training workshops will be provided to parents via the implementation of our parent engagement and implementation of our Parent University program.

FUNDING SOURCE/AND AMOUNT

The funding source recommended is the TWC subsidies and average daily attendance for MCISD staff.

RECOMMENDATION

As per CH(Local) the Board delegates to the Superintendent the authority to enter into interlocal cooperation contracts under Chapter 791 of the Government Code, subject to the following restrictions: This authority extends only to those interlocal contracts that have a term of not more than one calendar year or may be terminated at the District's convenience at any time with no cost of penalty. Additionally, with respect to interlocal cooperation contracts that require an expenditure of District funds, the authority granted under this paragraph extends only to budgeted expenditures that are less than \$50,000.

This is an information item and no action is required.

CONTACT PERSON(S)

Lorena Garcia, Deputy Supt. for Support Services
Dr. Sharon Roberts Deputy Superintendent for Curriculum and Instruction

**MEMORANDUM OF UNDERSTANDING
BETWEEN
MISSION CONSOLIDATED INDEPENDENT
SCHOOL DISTRICT AND
KIDS U US INC DBA FUELING BRAINS
ACADEMY**

**For the Delivery of Comprehensive Pre-K Educational services
FOR THE MISSION CONSOLIDATED INDEPENDENT
SCHOOL DISTRICT**

This Memorandum of Understanding (“MOU”) is entered into by and between the MISSION CONSOLIDATED INDEPENDENT SCHOOL DISTRICT (“MCISD” or “District”) and Fueling Brains (“FB”), a profit corporation, to provide comprehensive prekindergarten education services and resources to eligible children who are residents of the District and the surrounding area according to the terms and conditions set forth herein.

WHEREAS, FB is an Early Childhood Center Operator and Education Provider fostering to progressively develop executive functions capacity in child brain development through establishing a facility for care, conducive educational environment, and parent university services for eligible children;

WHEREAS, With this initiative, the primary focus for the 2022-2023 School Year is to increase enrollment in the PreK 3 and PreK 4 classrooms. By creating a consistent magnet program for all 3- and 4-year-olds, the Early Learning Academies Powered by Fueling Brains, across the 14 campuses, fully operated by FB, will provide fully ready Kindergarten- (5-year-old) children into the Mission CISD feeder patterns.

WHEREAS FB wishes to offer its services and resources to the MCISD for before and after school care for PK 3 to 5th-grade students and full-day dually enrolled PK 3 and PK 4 students with MCISD and FB;

WHEREAS, the MCISD recognizes the benefits of the FB program for the educational child brain development and care of the community’s children; and

WHEREAS, the MCISD seeks to cooperate, whenever possible, with other community service agencies for the betterment of families and children in the MCISD;

NOW, THEREFORE, in consideration of the mutual promises and undertakings reflected in this MOU, the receipt and sufficiency of which are hereby acknowledged, FB and MCISD, intending to be legally bound, agree to the following:

1. **Term.** This MOU is effective on the date of approval by MCISD’s Board of Trustees and will continue in effect through three school years with an option to renew for two additional years. The initial term shall be for the remainder of the 2021-2022 school year through the 2024-2025 school year. This MOU may be renewed for subsequent terms upon mutual written agreement of FB and MCISD.

2. **Termination.** Either party may terminate this MOU for failure to meet any obligations outlined in this agreement by giving forty-five (45) days advance written notice to the other party; in the event of termination, the effective date of termination will be the day after the end of the MCISD school year during which the 45-day period expires, or as otherwise mutually agreed to by the parties. The parties agree to cooperate upon the termination of this MOU to minimize disruption to students and parents. Upon termination of this MOU, FB shall be responsible for notifying affected parents in a neutral manner of the termination date of the program.

3. **Rights and Responsibilities of FB.** FB Shall:
 - a. In the 2021-2022 School Year, FB will pilot the program at selected campuses (Escobar Rios Elementary and Alton Elementary). By 2022-2023, all 14 campuses' PreK 3 and PreK 4 Classrooms will be Licensed and fully operating under FB.
 - b. Be responsible for Academy management and routine execution functions at MCISD designated facilities.
 - c. Serve a maximum of twenty (22) 3- and 4-year-old students per classroom dually enrolled with the MCISD and FB Program from 06:30 a.m. to 06:00 p.m. daily, according to MCISD's school calendars.
 - d. Serve PK 3 through 5th-grade students in the FB before/after-school program is a full-time childcare program that operates before school starts (6:00 am to 7:30 am) and after school ends (3:30 pm to 6:00 pm). The times are adjusted according to each school's schedule. Overlapping periods will be adjusted based on student enrollment, time, length of tasks, and time-lapse between tasks. Early dismissal days, staff development days, Spring Break, and during the summer, the program will offer additional enrichment programming services.
 - e. Subsidize up to 20% of the total allocated funding that should be received for students through the Texas Workforce Commission. The program will serve under the Texas Childcare Licensing Regulations as provided by the Human and Health Services Department and the state of Texas.
 - f. To increase enrollment FB will schedule its marketing and branding campaigns throughout the district.
 - g. Establish a conducive environment for the FB Approach necessary for Child Brain Development as per MCISD Curriculum. Research-based curriculum activities and assessment application systems to picture progressive child brain development give the added advantage of monitoring the executive functions i.e., inhibitory control, cognitive flexibility, and working memory of the child's brain development. However, adherence to the State guidelines for any other screening or assessment will be ensured by FB.
 - h. Provide a safe and secure environment for students. FB will ensure the availability of all facilities required under TEA guidelines, however, identification of requirements as per TEA will be the responsibility of MCISD. The facilities include but are not limited to Kitchen and nutrition safeties, play areas, environment safety, health safeties, corridors, conference rooms, etc.
 - i. Ensure measures to address COVID-19 or other pandemic-related diseases, as identified by MCISD.
 - j. Waive building use fees and utility bills.
 - k. Make available to students, breakfast, and lunch served at times that are mutually agreeable to all concerned (i.e., Supervisor, Nutritionists, etc.).

- l. Make available and ensure student access to playground facilities and equipment, common areas, and restrooms, as per TEA guidelines and identified requirements of MCISD.
- m. Creation of a daily schedule allowing each teaching staff member to planning time, as well as identification of instructional duties.
- n. Unless the student: teacher ratio increases, based on child care licensing standards, each classroom will be assigned one Lead Teacher and one Assistant teacher, provided by MCISD.
- o. Include instructional setting options consisting of bilingual, ESL, and/or general education, depending on the needs of the community, and curriculum and instruction plans consistent with MCISD's established curriculum and instruction plans and requirements.
- p. Assume full responsibility for all aspects of the Academy requirements, including, but not limited to:
 - (1) increased ratio of attention from the teacher to children (lesson delivery, academic progress, monitoring/safety, classroom safety);
 - (2) safety inspection upon arrival/dismissal;
 - (3) increased instructional support per classroom (joint planning/lesson delivery);
 - (4) coordinated effort in health and well-being (hearing, vision, immunization, height, and weight);
 - (5) strong parent engagement via Parent University; parents having the opportunity to extend classroom learning via activities at home including the FB app;
 - (6) help to ease the transition from Pre-Kindergarten to Kindergarten for participating children and families; and
 - (7) staff attendance at professional development training.
- q. Establish a procedure in collaboration with MCISD to collect registration information on potential eligible students enrolled with the Academy.
- r. Assume full responsibility for ensuring that all applicable state and federal laws, regarding playground facilities and equipment, are implemented and followed.
- s. Provide developmentally appropriate curriculum and content area support for children, and staff assigned, in compliance with all applicable state and federal laws and applicable federal award requirements.
- t. Provide all supplies, equipment, and products needed for the implementation of the FB Approach.
- u. Conduct several assessments/screenings during the year, enter results in the FB data system/app, and file results in the class and individual student records.
- v. Employ and assign a Director for the Academy that will assist the FB and MCISD in all duties and roles and responsibilities related to the collaboration between FB and MCISD under this MOU. Not limited to the above duties and responsibilities, Director selection and performance will comply with Minimum Standard State guidelines for Daycare centers.
- w. Director and teachers will adhere to the mission statements of FB and MCISD.
- x. MCISD applicant teachers shall be screened by FB's Human Resources Department. FB reserves the right to request to be included in the interviews for Academy applicants who will be assigned to the Day Care Center. FB further reserves the right to, subject to applicable law, have MCISD immediately remove and replace any teacher working in a Day Care Center.

- y. FB assumes full responsibility for the actions of its employees, contractors, and agents and shall remain solely responsible for their supervision, direction and control, payment of salary, workers' compensation, disability benefits, and other requirements and obligations. FB agrees that MCISD has no responsibility for any conduct of FB or FB's employees, contractors, or agents. FB further agrees that FB's employees are not entitled to receive employee benefits of any kind from MCISD. FB agrees that it and its employees are independent contractors, and while providing services under this MOU, are not employees of MCISD and have no authority to obligate or bind MCISD in any way to third parties without the express written permission of MCISD's Superintendent.
- z. FB shall conduct required background checks in accordance with applicable law. FB must certify that for each covered employee of FB who will have direct contact with students, FB has obtained, as required by Texas Education Code Section 22.0834: (a) state criminal history record information from law enforcement or criminal justice agency or a private entity that is a consumer reporting agency governed by the Fair Credit Reporting Act (15 U.S.C. Section 1681 et seq.) for each covered employee of FB employed before January 1, 2008; and (b) national criminal history record information for each employee of FB employed on or after January 1, 2008. FB will also obtain similar certifications of compliance with Texas Education Code Chapter 22's requirements from any subcontractors. Covered employees with disqualifying criminal history are prohibited from serving at the Center; FB and any subcontracting entity may not permit a covered employee to provide services at a school if the employee has been convicted of a felony or misdemeanor offense that would prevent a person from being employed under Tex. Educ. Code § 22.085(a) (i.e., Title 5 felony or an offense requiring registration as a sex offender and victim was under 18 years of age or was enrolled in a public school at the time the offense occurred).
- aa. FB shall collaborate with MCISD for the evaluation of teachers and aides provided pursuant to this MOU.
- bb. FB's staff shall comply with all applicable MCISD policies and procedures, including, without limitation, the dress and grooming code, emergency procedures, etc.
- cc. Timely provide MCISD with operating reports, on a schedule to be mutually agreed upon, in writing. Such reports shall include, but not be limited to, enrollment and attendance reports and foodservice reports/billing.
- dd. Administer all assessments and screenings required by either applicable state or federal law, required by MCISD, and/or in accordance with the terms of this MOU, to students and provide assessment data to MCISD, with parental consent, if required, to be obtained by FB.
- ee. FB's staff/teachers will supervise students at all times, including, without limitation:
 - (1) Supervising and coordinating drop off and pick up of students, in the area(s) designated. Parents of students will provide transportation to and from the childcare site. FB shall have no obligation to provide transportation to and/or from the childcare site to students who reside inside/outside the District.
 - (2) Walking students to and from the cafeteria, playground areas, or any other part of the Center.
 - (3) Sit with and assist students with their breakfast, snack, lunch, and dinner meals.
 - (4) Receive and address parental complaints or concerns in accordance with FB's policies. FB considers Parents as partners in child brain development and will provide access to Parent University application for child enhanced experiences away from the Center.

- (5) Take all measures for Child Care Center licensing as per the guidelines of Texas Health and Human Services. However, MCISD is also expected to follow State or LEA guidelines, as and when, required for the finalization of the collaboration agreement.
- ff. Provide \$1000 per child in FF&E given a 3-year commitment contract. For a five-year commitment, FB will commit up to \$1500 per child in FF&E. *Note: These dollars are for children eligible through the P3 partnership.
4. **Rights and Responsibilities of MCISD.** MCISD shall:
- a. Make available up to five classrooms per elementary campus for approximately 22 Pre-K 3 and Pre-K 4 students of MCISD.
 - b. Make available appropriate furnishings for the classrooms.
 - c. Provide internet and telephone services to all classrooms, as identified by MCISD.
 - d. Identifying and registering children for the Academy will be MCISD responsibility as well as parent notices and communication, in collaboration with FB. However, such a procedure will be jointly developed and mutually agreed upon by MCISD and FB.
 - e. Provide Lead teacher and Assistant teacher for the two classrooms unless the student: teacher ratio increases, based on child care licensing standards or TEA guidelines.
 - f. Assumes full responsibility for the actions of its employees, contractors, and agents and shall remain solely responsible for their payment of salary, workers' compensation, disability benefits, and other requirements and obligations. MCISD agrees that FB has no responsibility for any conduct of MCISD, except for the terms mentioned in the MOU.
 - g. FB shall provide daily supervision, direction, and control of MCISD teachers, and MCISD will implement measures to ensure teachers are oriented and familiar with FB center policies and procedures. MCISD and FB shall collaborate regarding teacher performance concerns, however, MCISD retains final oversight and direction of MCISD employees, including, but not limited to, matters of employee discipline and/or termination.
 - h. Identify minimum content area requirements or facilities in accordance and compliance with TEA guidelines.
 - i. Take all reasonable steps for collaboration, coordination, and provision of community services to the Center.
 - j. Provide transportation support for outdoor trips, as and when planned. However, trips will be planned in coordination by Director, Academy, and MCISD representatives.
5. **Rights and Responsibilities of MCISD and FB.** MCISD and FB shall:
- a. Develop a joint co-branding and marketing public awareness plan which shall include information concerning both MCISD and FB Academy.
 - b. When MCISD conducts a meeting to discuss students' academic and /or behavioral performance, the appropriate FB representative (Director) will be invited to attend the meeting.
6. **High Needs Students.** The Academy is not equipped with facilities to support high-needs students. MCISD will screen the prospective students during the eligibility consideration process and determine appropriate placement in other MCISD facilities, as required by law.

7. **Compliance with Laws.** FB shall comply with all applicable federal, state, and local laws, statutes, ordinances, rules, and regulations, including, if applicable, workers' compensation laws, minimum and maximum salary and wage statutes and regulations, prompt payment and licensing laws, and regulations. For the entire duration of this MOU, FB shall maintain all required licenses, certifications, permits, and any other documentation necessary to perform this MOU and provide MCISD services and resources. When required or requested by MCISD, FB shall furnish MCISD with satisfactory proof of FB's compliance with this provision.
8. **Liability Insurance Requirements.** FB agrees to obtain and maintain in full force and effect, during the term of this MOU, the policies of insurance as required and MCISD agrees to maintain in full force and effect, during the term of this MOU, insurance policies as needed.
9. **FB Property.** In the event of loss, damage, or destruction of any property owned by or loaned by FB that is undisputed to have been caused by MCISD or MCISD's representative, agent, employee, or contractor, MCISD shall pay to FB the full value of or the full cost of repair or replacement of such property, whichever is less, within thirty (30) days of MCISD's receipt of written notice of FB's determination of the amount due and processing by MCISD insurance agent.
10. **Confidentiality.** FB and MCISD agree to secure the confidentiality of all information and records in accordance with applicable federal and state laws, rules, and regulations. FB and MCISD understand that the Family Educational Rights and Privacy Act (FERPA), 20 U.S.C. § 1232g, governs the privacy and security of educational records and information and agrees to abide by FERPA rules and regulations, as applicable. FB also acknowledges that MCISD is subject to the Texas Public Information Act, and FB waives any claim against and releases from liability MCISD, its officers, employees, agents, and attorneys concerning disclosure of information provided under or in this MOU or otherwise created, assembled, maintained, or held by FB and determined by MCISD, the Attorney General of Texas, or a court of law to be subject to disclosure under the Texas Public Information Act.
11. **Equal Opportunity.** It is the policy of FB not to discriminate based on race, color, national origin, gender, limited English proficiency, or handicapping conditions in its programs. MCISD agrees not to discriminate against any employee or applicant for employment to be employed in the performance of this MOU, with respect to hiring, tenure, terms, conditions, and privileges of employment, or a matter directly or indirectly related to employment, because of age (except where based on a bona fide occupational qualification), sex (except where based on a bona fide occupational qualification) or race, color, religion, national origin, or ancestry. FB and MCISD further agree every subcontract entered into for the performance of this MOU shall contain a provision requiring nondiscrimination in employment herein specified, binding upon each subcontractor. Breach of this covenant may be regarded as a material breach of the MOU.

12. Indemnification. MCISD and its trustees, officers, employees, or agents shall have no liability or responsibility for any claim or cause of action of any person or group arising from (a) the use of the FB Location by FB and FB officers, volunteers, employees, contractors, agents, invitees, licensees, students, and visitors, or (b) FB's non-compliance with this MOU, or (c) any act, omission, or negligence of FB, or any of its officers, agents, employees, contractors, invitees, licensees, volunteers, students, or visitors. **FB AGREES THAT FB SHALL INDEMNIFY, DEFEND, AND HOLD HARMLESS MCISD AND MCISD PAST, PRESENT, AND FUTURE TRUSTEES, OFFICERS, AND EMPLOYEES, FROM AND AGAINST ALL CLAIMS, DEMANDS, CAUSES OF ACTION, DAMAGES, COSTS, AND EXPENSES, INCLUDING, WITHOUT LIMITATION, COURT COSTS AND REASONABLE ATTORNEYS' FEES, OF ANY KIND OR NATURE, ASSERTED BY ANY THIRD PARTY, OCCURRING OR IN ANY WAY INCIDENT TO, ARISING OUT OF, OR IN CONNECTION WITH ANY ACTS OF FB AND/OR THE FB'S EMPLOYEES, CONTRACTORS, AGENTS, STUDENTS AND PARENTS IN CONNECTION WITH THIS MOU. FB'S OBLIGATIONS UNDER THIS CLAUSE SHALL SURVIVE TERMINATION OR EXPIRATION OF THIS MOU. TO THE EXTENT ALLOWED BY LAW, MCISD AGREES THAT MCISD SHALL INDEMNIFY, DEFEND, AND HOLD HARMLESS FB AND FB'S PAST, PRESENT, AND FUTURE TRUSTEES, OFFICERS, AND EMPLOYEES, FROM AND AGAINST ALL CLAIMS, DEMANDS, CAUSES OF ACTION, DAMAGES, COSTS, AND EXPENSES, INCLUDING, WITHOUT LIMITATION, COURT COSTS AND REASONABLE ATTORNEYS' FEES, OF ANY KIND OR NATURE ASSERTED BY ANY THIRD PARTY, ARISING OUT OF, OR IN CONNECTION WITH ANY ACTS OF MCISD AND/OR MCISD'S EMPLOYEES, CONTRACTORS, AGENTS, IN CONNECTION WITH THIS MOU. MCISD'S OBLIGATIONS UNDER THIS CLAUSE SHALL SURVIVE TERMINATION OR EXPIRATION OF THIS MOU.**

13. Right to Audit. MCISD, upon written notice, shall have the right to audit Center records and accounts relating to this MOU. Records subject to audit shall include but are not limited to, records that may have a bearing on matters of interest to MCISD in connection with FB's provision of services and shall be open to inspection and subject to audit and/or reproduction by MCISD or its authorized representative(s) to the extent necessary to adequately permit evaluation and verification of:

- (1) FB's compliance with this MOU,
- (2) compliance with applicable MCISD policies and procedures,
- (3) compliance with applicable laws, and/or
- (4) any other matters related to this MOU.

14. Dispute Resolution. In the event that logistical or other problems arise during the implementation of this MOU, the local representatives of MCISD and Director FB will attempt to resolve such matters. If, however, the resolution is not achieved at this level, the matter may be referred to the next senior titles of FB and MCISD, who will work together to satisfactorily resolve the problem or concern.

15. **Notice.** All notices or other communications required or permitted hereunder shall be in writing, and shall be personally delivered or sent by registered or certified mail, return receipt request, courier delivery, or receipted overnight mail, and shall be deemed received upon the earlier of (a) the date of delivery, if personally delivered, or (b) three (3) business days after the date of posting by the U.S. postal service if mailed. All such notices or communications shall be addressed as follows:

If to MCISD: Dr. Carol G. Perez
 Superintendent
 1201 Bryce Drive
 Mission, TX 78572

With a copy to Joel Garcia
 Assistant Superintendent for Finance
 1201 Bryce Drive
 Mission, TX 78572

If to FB: Anil Karim
 Co-Founder/CEO
 8631 Pottinger Dr
 Houston, TX 77083

With a copy to: Faisal Alimohd
 Co-Founder/CFO
 11438 Braeside Drive SW
 Calgary, Alberta T2W4X8

Either party may change such address for notice for the party designated to receive such notice by giving advance written notice to the other party as provided in this paragraph.

16. **No Waiver of MCISD's Immunity.** The execution of this MOU and the performance by MCISD of any of its obligations hereunder are not, and are not intended to waive or relinquish, and MCISD shall not waive or relinquish, any governmental, sovereign immunity or defense from or to liability or prosecution available to MCISD, its trustees, officers, employees, or agents under federal or Texas laws.

17. **No Third-Party Beneficiaries.** Nothing in this MOU shall be deemed or construed to create any third party beneficiaries or otherwise give any third party any claim or right of action against any party to this MOU.

18. **Governing Law and Venue.** This MOU shall be governed by and construed in accordance with the laws of the State of Texas, without regard to its conflicts of laws provisions. The mandatory and exclusive venue for the adjudication or resolution of any dispute arising out of this Agreement shall be in Hidalgo County, Texas.
19. **Entire Agreement.** This MOU and the attached and incorporated addendum or exhibit, if any, contain the entire agreement of the parties relative to the purpose(s) of the MOU and supersede any other representations, agreements, arrangements, negotiations, or understanding, oral or written, between the parties to this MOU.
20. **Severability.** In the event that any one or more of the provisions contained in this MOU shall for any reason be held to be invalid, illegal, or unenforceable in any respect, such invalidity, illegality, or unenforceability shall not affect any other provisions, and the MOU shall be construed as if such invalid, illegal, or unenforceable provision had never been contained in it.
21. **Interpretation.** The parties agree that the normal rules of construction that require that any ambiguities in this MOU are to be construed against the drafter shall not be employed in the interpretation of this MOU.
22. **Changes and Amendments.** This MOU may be amended, modified, and/or supplemented only by the mutual agreement of the parties, in writing, to be attached to and incorporated in this MOU.
23. **Assignment.** Neither this MOU nor any rights, duties, or obligations under it shall be assignable by either party without the prior written acknowledgment and authorization of the other party. Any attempted assignment without prior written consent shall be void.
24. **No Waiver.** No failure on the part of either party at any time to require the performance by the other party of any term hereof shall be taken or held to be a waiver of such term or in any way affect such party's right to enforce such term, and no waiver on the part of either party of any term hereof shall be taken or held to be a waiver of any other term hereof or the breach thereof. No waiver, alteration, or modification of any of the provisions of this MOU shall be binding unless in writing and signed by duly authorized representatives of the parties hereto.
25. **Captions.** The captions herein are for convenience and identification purposes only, are not an integral part hereof, and are not to be considered in the interpretation of any part hereof.
26. **Counterparts.** This MOU may be executed in separate counterparts, each of which when so executed shall be an original, but all of such counterparts shall together constitute but one and the same instrument.

27. **Representations.** MCISD and FB hereby certify, as to each of them individually: (1) the responsibilities specified herein are properly within its legal functions; (2) it is legally authorized to perform the required duties of this MOU; and (3) this MOU has been duly authorized by its governing body. FB further certifies that it is not presently debarred, suspended for debarment, declared ineligible, or voluntarily excluded from covered transactions by any federal department or agency.

AGREED to this _____ day of _____, 2022.

ATTEST:

MISSION CONSOLIDATED INDEPENDENT SCHOOL DISTRICT

Dr. Carol G. Perez
Superintendent
Mission CISD

Date

FUELING BRAINS

(Faisal Alimohd)
(Co-Founder/CFO)
Fueling Brains

Date

SUBJECT: Personnel Employments, Resignations, Transfers and Compensation Changes

PRESENTER: Dr. Carol G. Perez, Superintendent

BACKGROUND INFORMATION

Professional employees and support staff members have been employed by the Mission Consolidated Independent School District. Employees requested and were granted transfers that affected their campus, position title and/or pay grade, or were reassigned, which affected their campus, position title and/or pay grade.

Letters of resignation and letters of retirement were received from Mission CISD employees.

Changes in compensation to employees after performance on the contract or duties for the job assignment have begun (subsequent to the March 9, 2022, report to the Board) are also included for staff members.

FUNDING SOURCE:

See Attachments

RECOMMENDATION:

No recommendation or action required. For Information Only.

CONTACT PERSON(S):

Lorena Garcia, Deputy Superintendent for Support Services
Elisa Pacheco, Director for Human Resources

SUBJECT: General Fund and Debt Service Financial Report for February 2022

PRESENTER: Joel Garcia, Assistant Superintendent for Finance

BACKGROUND INFORMATION

As per Board Policy CFA (LEGAL), The Board shall prepare an annual financial statement that shows the following for each fund subject to its authority during the fiscal year:

1. The total receipts of the fund, itemized by the source of revenue, including taxes, assessments, service charges, grants of state money, gifts, or other general sources from which funds are derived.
2. The total disbursements of the fund, itemized by the nature of the expenditure.
3. The balance in the fund at the close of the fiscal year.

Monthly financial reports are prepared throughout the year by Administration for information purposes only.

ADMINISTRATIVE CONSIDERATIONS

The General Fund Financial reports compare the budgeted revenues and expenditures.

Actual revenues for February 2022 totaled \$109,321,979 and actual expenditures totaled \$79,309,100. The excess total revenues over expenditures and other operating uses is \$30,046,320.

These numbers do not include outstanding encumbrances for payroll and supplies. Budget by function is sufficient to meet expenditures.

The Debt Fund financial report is also attached.

FUNDING SOURCE AND AMOUNT

Not applicable.

RECOMMENDATION

Information item only.

CONTACT PERSON(S)

Joel Garcia, Assistant Superintendent for Finance
Anna Zuniga, CPA Director for Finance

Mission Consolidated Independent School District

General Fund

February 28, 2022

		Budget	Actual	Difference	%
Revenues					
5700	Local and Intermediate Sources	\$ 27,728,439	\$24,210,378	\$ (3,518,061)	87.31%
5800	State Program Revenues	130,446,452	74,063,777	(56,382,675)	56.78%
5900	Federal Program Revenues	22,687,952	11,047,824	(11,640,128)	48.69%
	Total Revenues	\$ 180,862,843	\$ 109,321,979	\$ (71,540,864)	
Expenditures					
11	Instruction	\$ 72,359,377	\$29,071,954	\$ 43,287,423	40.18%
12	Instrucional Resources & Media Services	2,550,886	1,121,619	1,429,267	43.97%
13	Curriculum and Personnel Development	2,217,266	1,165,393	1,051,873	52.56%
21	Instructional Administration	2,889,175	1,644,941	1,244,234	56.93%
23	School Administration	9,755,661	5,314,651	4,441,010	54.48%
31	Guidance and Counseling Services	6,170,180	3,138,722	3,031,458	50.87%
32	Attendance and Social Work Services	587,220	329,381	257,839	56.09%
33	Health Services	1,974,424	950,498	1,023,926	48.14%
34	Pupil Transportation	6,481,181	2,837,584	3,643,597	43.78%
35	Food Services	15,337,531	9,167,763	6,169,768	59.77%
36	Co-Curricular Activities	8,522,508	3,736,503	4,786,005	43.84%
41	General Administration	6,050,081	3,684,902	2,365,179	60.91%
51	Plant Maintenance and Operations	34,477,082	12,082,311	22,394,771	35.04%
52	Security and Monitoring	3,556,603	1,570,862	1,985,741	44.17%
53	Data Processing Services	3,335,115	2,040,208	1,294,907	61.17%
61	Community Services	399,873	152,183	247,690	38.06%
71	Debt Service	1,036,320	866,318	170,002	83.60%
81	Facilities Acquisition and Construction	8,709,628	214,135	8,495,493	2.46%
95	Juvenile Justice Alt. Education	20,000	-	20,000	0.00%
99	Other Intergovernmental Charges	296,080	219,174	76,906	0.00%
	Total Expenditures	\$ 186,726,191	\$79,309,100	\$ 107,417,091	0
1100	Excess (Deficiency)	\$ (5,863,348)	\$30,012,879	\$ 35,876,227	
Non-Operating Revenue					
7912	Sale of Real or Personal Property	\$ 132,680	\$ 33,441	\$ (99,239)	25.20%
7915	Operating Transfers In	16,480,615	\$ -	(16,480,615)	0.00%
	Total Non-Operating Revenue	\$ 16,613,295	\$ 33,441	\$ (16,579,854)	
Non-Operating Expenses					
8911	Other Uses	\$ (18,022,997)	\$ -	\$ (18,022,997)	0.00%
	Total Non-Operating Expenses	\$ (18,022,997)	\$ -	\$ (18,022,997)	
1200	Excess (Deficiency)	\$ (7,273,050)	\$ 30,046,320	\$ 1,273,376	
0100	Fund Balance - Beginning Audited	\$ 80,898,169	\$ 80,898,169	\$ -	
3000	Fund Balance - Ending Un-Audited	\$ 73,625,119	\$ 110,944,489	\$ 1,273,376	

Mission Consolidated Independent School District

February 28, 2022

DEBT SERVICE FUND 599

		Budget	Actual	Difference	%
Revenues					
5700	Local and Intermediate Sources	\$ 4,182,889	\$ 3,909,015	\$ (273,874)	93.45%
5800	State Program Revenues	4,274,159	3,902,778	(371,381)	91.31%
	Total Revenues	\$ 8,457,048	\$ 7,811,793	\$ (645,255)	
Expenditures					
71	Debt Services	\$ 8,457,048	\$ 8,442,847	\$ 14,201	99.83%
	Total Expenditures	\$ 8,457,048	\$ 8,442,847	\$ 14,201	
1100	Excess (Deficiency)	\$ -	\$ (631,054)	\$ (631,054)	
Non-Operating Revenue					
7900	Operating Transfers In	\$0	\$0	\$0	0.00%
Non-Operating Expenses					
8900	Operating Transfers Out	\$ -	\$ -	\$ -	0.00%
1200	Excess (Deficiency)	\$ -	\$ (631,054)	\$ (631,054)	
0100	Fund Balance - Beginning Audited	\$ 5,114,405	\$ 5,114,405	\$ -	
3000	Fund Balance - Ending Un-Audited	\$ 5,114,405	\$ 4,483,351	\$ (631,054)	

SUBJECT: Tax Levy Adjustments for the Month of February 2022

PRESENTER: Joel Garcia, Assistant Superintendent for Finance

BACKGROUND INFORMATION

The Hidalgo County Assessor & Collector has been collecting the District's taxes since December 1999. Both current and delinquent taxes are collected by Hidalgo County on our behalf.

ADMINISTRATIVE CONSIDERATIONS

Tax roll adjustments due to corrections, rollbacks, homesteads, dropped years, etc., resulted in a net decrease of \$26,262.61. Adjustments are reviewed and posted to the general ledger on a monthly basis. These modifications are included as part of the monthly tax report.

Collections totaled \$2,974,911.94. The monthly fee for this service is \$6,271.00.

Attached is the February 2022 Tax Collection Report

FUNDING SOURCE AND AMOUNT

Local Maintenance Levy Modification \$(46,609.85)
Debt Service Levy Modification \$(7,719.03)
Rollbacks \$28,066.27

RECOMMENDATION:

Tax Levy Adjustments for the month of February 2022

CONTACT PERSON (S)

Joel Garcia, Assistant Superintendent for Finance
Anna Zuniga, CPA Director of Finance
Rosalinda Rodriguez, Accountant

PABLO "PAUL" VILLARREAL JR., ASSESSOR & COLLECTOR
MISSION C.I.S.D. TAXES COLLECTED FOR:
FEBRUARY 2022

COMPARATIVE RATE OF COLLECTIONS

MISSION C.I.S.D. SMS - 48	ORIGINAL TAX LEVY	COLLECTED TO DATE	DROPPED YRS AFTER PURGE	MODIF. TO DATE	TAXES OUTSTANDING	PERCENT 2021/2022	COLLECTED 2020/2021
2021 TAX ROLL	28,363,668.26	25,899,531.33	-	666,351.94	3,130,488.87	89.22%	87.64%
2020 & PRIOR YRS	4,597,051.27	1,105,057.00	(26,936.59)	(81,211.45)	3,383,846.23	24.62%	24.69%
ROLLBACK	8,099.31	3,081.26	-	28,066.27	33,084.32	8.52%	75.15%
TOTALS	32,968,818.84	27,007,669.59	(26,936.59)	613,206.76	6,547,419.42		

BREAKDOWN OF TAX COLLECTIONS AND FEES FOR THE MONTH OF FEBRUARY 2022

	MISSION C.I.S.D.	MONTHLY MODIFICATIONS
CURRENT YEAR-BASE TAX	2,657,839.21	(43,130.86) CURRENT
CURRENT YEAR-P&I	95,934.93	
PRIOR YEARS-BASE TAX	137,593.79	(11,198.02) PRIOR
PRIOR YEARS-P&I	55,082.63	
ROLLBACK		28,066.27 ROLLBACK
ROLLBACK P&I	-	
ATTORNEY FEES	28,461.38	PURGED
TOTAL COLLECTIONS	2,974,911.94	(26,262.61)
LESS TRANSFERRED	2,398,516.62	
LESS IN TRANSIT	569,864.15	
LESS DUE TO HCAD COMM FEES	260.17	
LESS DUE TO CO TREASURER	6,271.00	
BALANCE	(0.00)	

*****AFFIDAVIT*****

I, PABLO "PAUL" VILLARREAL JR., ASSESSOR-COLLECTOR OF TAXES FOR THE MISSION C.I.S.D., DO SOLEMNLY SWEAR THAT THE ABOVE STATEMENT OF TAXES COLLECTED BY ME FOR THE MONTH OF FEBRUARY IS CORRECT.

Pablo Villareal Jr.
ASSESSOR-COLLECTOR OF TAXES FOR MISSION C.I.S.D., TEXAS

SWORN AND SUBSCRIBED BEFORE ME THIS 10TH DAY OF MARCH 2022 A.D.

Rita Rebecca Vargas
NOTARY PUBLIC, HIDALGO COUNTY, TEXAS



**HIDALGO COUNTY TAX OFFICE
MISSION CISD**

MODIFICATIONS FOR THE MONTH OF FEBRUARY 2022

YR	RATE	M&O	%	ADJ	M&O	I&S	%	I&S
2021	1.1332	0.9719	85.77%	(43,130.86)	(36,991.60)	0.1613	14.23%	(6,139.26)
2020	1.19930	1.02800	85.72%	(6,637.01)	(5,689.02)	0.1713	14.28%	(947.99)
2019	1.23955	1.06835	86.19%	(4,598.98)	(3,963.79)	0.1712	13.81%	(635.19)
2018	1.3398	1.1700	87.33%	156.51	136.67	0.1698	12.67%	19.84
2017	1.3502	1.1700	86.65%		0.00	0.1802	13.35%	0.00
2016	1.3582	1.1700	86.14%	(118.54)	(102.11)	0.1882	13.86%	(16.43)
2015	1.3672	1.1700	85.58%		0.00	0.1972	14.42%	0.00
2014	1.3300	1.1700	87.97%		0.00	0.1600	12.03%	0.00
2013	1.3000	1.1700	90.00%		0.00	0.1300	10.00%	0.00
2012	1.3000	1.1700	90.00%		0.00	0.1300	10.00%	0.00
2011	1.3000	1.1700	90.00%		0.00	0.1300	10.00%	0.00
2010	1.3000	1.0400	80.00%		0.00	0.2600	20.00%	0.00
2009	1.2800	1.0400	81.25%		0.00	0.2400	18.75%	0.00
2008	1.2400	1.0400	83.87%		0.00	0.2000	16.13%	0.00
2007	1.1800	1.0400	88.14%		0.00	0.1400	11.86%	0.00
2006	1.4574	1.3374	91.77%		0.00	0.1200	8.23%	0.00
2005	1.5632	1.4632	93.60%		0.00	0.1000	6.40%	0.00
2004	1.5691	1.4632	93.25%		0.00	0.1059	6.75%	0.00
2003	1.5841	1.4632	92.37%		0.00	0.1209	7.63%	0.00
2002	1.5841	1.4500	91.53%		0.00	0.1341	8.47%	0.00
2001	1.5341	1.4394	93.83%		0.00	0.0947	6.17%	0.00
2000	1.5341	1.4000	91.26%		0.00	0.1341	8.74%	0.00
1999	1.5050	1.4208	94.41%		0.00	0.0842	5.59%	0.00
TOTAL				(54,328.88)	(46,609.85)			(7,719.03)

	M&O	I&S
2021	(43,130.86)	(6,139.26)
2020 & PRIOR	(11,198.02)	(1,579.77)
TOTAL	(54,328.88)	(7,719.03)

ROLLBACK MODIFICATIONS FOR THE MONTH OF FEBRUARY 2022

YR	RATE	M&O	%	ADJ	M&O	I&S	%	I&S
2021	1.1332	0.9719	85.77%	-	0.00	0.1613	14.23%	0.00
2020	1.1993	1.0280	85.72%	8,240.11	7,063.15	0.1713	14.28%	1,176.96
2019	1.2396	1.0684	86.19%	9,954.19	8,579.37	0.1712	13.81%	1,374.82
2018	1.3398	1.1700	87.33%	9,871.97	8,620.84	0.1698	12.67%	1,251.13
2017	1.3502	1.1700	86.65%	-	0.00	0.1802	13.35%	0.00
TOTAL				28,066.27	24,263.36			3,802.91

	M&O	I&S
CURRENT	-	-
DELINQUENT	28,066.27	3,802.91
TOTAL	28,066.27	3,802.91

YEAR	FUND	TAX RATE	LEVY PAID	DISCOUNT GIVEN	PENALTY INTEREST	TIF AMOUNT	DISBURSE TOTAL	ATTORNEY	OTHER FEES	REFUND AMOUNT	PAYMENT AMOUNT
2021	M & O	.971900	2,279,521.49	.00	82,279.49	.00	2,361,800.98	.00	.00	.00	2,361,800.98
	I & S	.161300	378,317.72	.00	13,655.44	.00	391,973.16	.00	.00	.00	391,973.16
	TOTAL	1.133200	2,657,839.21	.00	95,934.93	.00	2,753,774.14	.00	.00	.00	2,753,774.14
2020	M & O	1.028000	52,511.41	.00	13,583.50	.00	66,094.91	11,872.73	.00	.00	77,967.64
	I & S	.171300	8,750.08	.00	2,263.45	.00	11,013.53	.00	.00	.00	11,013.53
	TOTAL	1.199300	61,261.49	.00	15,846.95	.00	77,108.44	11,872.73	.00	.00	88,981.17
2019	M & O	1.068350	30,675.13	.00	12,201.43	.00	42,876.56	7,516.07	.00	.00	50,392.63
	I & S	.171200	4,915.55	.00	1,955.25	.00	6,870.80	.00	.00	.00	6,870.80
	TOTAL	1.239550	35,590.68	.00	14,156.68	.00	49,747.36	7,516.07	.00	.00	57,263.43
2018	M & O	1.170000	16,978.49	.00	7,565.11	.00	24,543.60	3,926.58	.00	.00	28,470.18
	I & S	.169800	2,464.03	.00	1,097.92	.00	3,561.95	.00	.00	.00	3,561.95
	TOTAL	1.339800	19,442.52	.00	8,663.03	.00	28,105.55	3,926.58	.00	.00	32,032.13
2017	M & O	1.170000	7,414.95	.00	3,904.14	.00	11,319.09	1,722.99	.00	.00	13,042.08
	I & S	.180200	1,142.02	.00	601.28	.00	1,743.30	.00	.00	.00	1,743.30
	TOTAL	1.350200	8,556.97	.00	4,505.42	.00	13,062.39	1,722.99	.00	.00	14,785.38
2016	M & O	1.170000	4,401.74	.00	2,559.96	.00	6,961.70	1,011.44	.00	.00	7,973.14
	I & S	.188200	708.04	.00	411.76	.00	1,119.80	.00	.00	.00	1,119.80
	TOTAL	1.358200	5,109.78	.00	2,971.72	.00	8,081.50	1,011.44	.00	.00	9,092.94
2015	M & O	1.170000	1,879.90	.00	1,588.55	.00	3,468.45	604.91	.00	.00	4,073.36
	I & S	.197200	316.85	.00	267.73	.00	584.58	.00	.00	.00	584.58
	TOTAL	1.367200	2,196.75	.00	1,856.28	.00	4,053.03	604.91	.00	.00	4,657.94
2014	M & O	1.170000	1,128.10	.00	1,072.77	.00	2,200.87	342.53	.00	.00	2,543.40
	I & S	.160000	154.28	.00	146.72	.00	301.00	.00	.00	.00	301.00
	TOTAL	1.330000	1,282.38	.00	1,219.49	.00	2,501.87	342.53	.00	.00	2,844.40
2013	M & O	1.170000	852.44	.00	929.18	.00	1,781.62	296.93	.00	.00	2,078.55
	I & S	.130000	94.73	.00	103.26	.00	197.99	.00	.00	.00	197.99
	TOTAL	1.300000	947.17	.00	1,032.44	.00	1,979.61	296.93	.00	.00	2,276.54
2012	M & O	1.170000	472.35	.00	559.31	.00	1,031.66	166.57	.00	.00	1,198.23
	I & S	.130000	52.49	.00	62.15	.00	114.64	.00	.00	.00	114.64
	TOTAL	1.300000	524.84	.00	621.46	.00	1,146.30	166.57	.00	.00	1,312.87
2011	M & O	1.170000	427.85	.00	559.27	.00	987.12	160.30	.00	.00	1,147.42
	I & S	.130000	47.53	.00	62.15	.00	109.68	.00	.00	.00	109.68
	TOTAL	1.300000	475.38	.00	621.42	.00	1,096.80	160.30	.00	.00	1,257.10
2010	M & O	1.040000	534.24	.00	739.41	.00	1,273.65	221.66	.00	.00	1,495.31
	I & S	.260000	133.56	.00	184.88	.00	318.44	.00	.00	.00	318.44
	TOTAL	1.300000	667.80	.00	924.29	.00	1,592.09	221.66	.00	.00	1,813.75

03/03/2022 19:13:15 3963963
 TC298-D SELECTION: SYSTEM
 RECEIPT DATE: ALL
 LOCATION: LOCATION NAME NOT FOUND

TAX COLLECTION SYSTEM
 DEPOSIT DISTRIBUTION
 FROM: 02/01/2022 THRU 02/28/2022
 JURISDICTION: 0048 MISSION CISD

PAGE: 80
 INCLUDES AG ROLLBACK

YEAR	FUND	TAX RATE	LEVY PAID	DISCOUNT GIVEN	PENALTY INTEREST	TIP AMOUNT	DISBURSE TOTAL	ATTORNEY	OTHER FEES	REFUND AMOUNT	PAYMENT AMOUNT
2009	M & O	1.040000	259.36	.00	407.19	.00	666.55	123.06	.00	.00	789.61
	I & S	.240000	59.85	.00	93.97	.00	153.82	.00	.00	.00	153.82
	TOTAL	1.280000	319.21	.00	501.16	.00	820.37	123.06	.00	.00	943.43
2008	M & O	1.040000	285.53	.00	482.55	.00	768.08	137.36	.00	.00	905.44
	I & S	.200000	54.91	.00	92.80	.00	147.71	.00	.00	.00	147.71
	TOTAL	1.240000	340.44	.00	575.35	.00	915.79	137.36	.00	.00	1,053.15
2007	M & O	1.040000	414.78	.00	707.56	.00	1,122.34	180.55	.00	.00	1,302.89
	I & S	.140000	55.84	.00	95.25	.00	151.09	.00	.00	.00	151.09
	TOTAL	1.180000	470.62	.00	802.81	.00	1,273.43	180.55	.00	.00	1,453.98
2006	M & O	1.337400	360.23	.00	695.24	.00	1,055.47	172.53	.00	.00	1,228.00
	I & S	.120000	32.32	.00	62.38	.00	94.70	.00	.00	.00	94.70
	TOTAL	1.457400	392.55	.00	757.62	.00	1,150.17	172.53	.00	.00	1,322.70
2004	M & O	1.463200	14.19	.00	24.72	.00	38.91	5.17	.00	.00	44.08
	I & S	.105900	1.02	.00	1.79	.00	2.81	.00	.00	.00	2.81
	TOTAL	1.569100	15.21	.00	26.51	.00	41.72	5.17	.00	.00	46.89
ALL	M & O		2,398,132.18	.00	129,859.38	.00	2,527,991.56	28,461.38	.00	.00	2,556,452.94
ALL	I & S		397,300.82	.00	21,158.18	.00	418,459.00	.00	.00	.00	418,459.00
ALL	TOTAL		2,795,433.00	.00	151,017.56	.00	2,946,450.56	28,461.38	.00	.00	2,974,911.94
DLQ	M & O		118,610.69	.00	47,579.89	.00	166,190.58	28,461.38	.00	.00	194,651.96
DLQ	I & S		18,983.10	.00	7,502.74	.00	26,485.84	.00	.00	.00	26,485.84
DLQ	TOTAL		137,593.79	.00	55,082.63	.00	192,676.42	28,461.38	.00	.00	221,137.80
CURR	M & O		2,279,521.49	.00	82,279.49	.00	2,361,800.98	.00	.00	.00	2,361,800.98
CURR	I & S		378,317.72	.00	13,655.44	.00	391,973.16	.00	.00	.00	391,973.16
CURR	TOTAL		2,657,839.21	.00	95,934.93	.00	2,753,774.14	.00	.00	.00	2,753,774.14

SUBJECT: Disbursements for the Month of February 2022

PRESENTER: Joel Garcia, Assistant Superintendent for Finance

BACKGROUND INFORMATION:

The District’s disbursements list all of the checks and other payments made during the reporting month. The check registers, wire transfers, and automated clearing house (ACH) transactions are available for inspection at the office of the Assistant Superintendent for Finance.

Monthly disbursement reports are prepared throughout the year by administration for information purposes only.

ADMINISTRATIVE CONSIDERATIONS:

The District’s total disbursements for the Month of February totaled \$19,842,126.37 as follows:

Disbursement Type	Amount
Accounts Payable Vendor Checks	\$ 2,016,661.26
District Purchasing Cards	\$ 895,350.07
ACH	\$ 1,565,847.00
Wire Transfers	\$ 7,652,592.36
Payroll	\$ 7,711,675.68
TOTAL	\$ 19,842,126.37

FUNDING SOURCE AND AMOUNT:

N/A

RECOMMENDATION:

Information Item.

CONTACT PERSON (S):

Joel Garcia, Assistant Superintendent for Finance
Anna Zuniga, CPA, Director for Finance
Rosalinda Rodriguez, Accountant

SUBJECT: Donations

PRESENTER: Joel Garcia, Assistant Superintendent for Finance

BACKGROUND INFORMATION

In accordance with Board Policy CDC (Legal), all bequest of property for the benefit of the public schools shall, when not otherwise directed by the grantor, vest the property in the Board. Funds or other property donated, or the income therefrom, may be expended:

1. For any purpose designated by the donor that is in keeping with the lawful purposes of the schools that are to benefit from the donation; or
2. For any legal purpose if the donor designated no specific purpose.

The district receives donations from various sources throughout the school year. The majority of donations are given to the student activity funds to be used for student travel and awards. Some donations are in cash and some are non-cash, such as equipment, food, and services.

AMINISTRATION CONSIDERATION

For the period reported, total donations were \$194,980.27. The largest cash donation received was \$2,970.00 and the largest non-cash donations received was \$145,283.33. These donations benefit our students.

FUNDING SOURCE AND AMOUNT

N/A

RECOMMENDATION:

No action needed only informational .

CONTACT PERSON (S)

Joel Garcia, Assistant Superintendent for Finance
Anna Zuniga, CPA, Director for Finance
Rosalinda Rodriguez, Accountant

Mission Consolidated Independent School District
Donations through March 2022

Date	Campus / Scholarship	Cash	Non-Cash	Donor	Purpose
02/02/22	Castro Elementary	250.00	-	Missio Fire Fighters	Donation to be used by campus
02/24/22	Mission High School	2,970.00	-	Mission Bank Booster	Donation to be used on charter bus for travel
02/24/22	Safety & Security	-	145,283.33	Breath for Life	Donation of 230,000 KN95 masks
03/01/22	District Wide	-	1,000.00	Greater Mission Chamber of Commerce & Mission Prosperity Ventures Foundation	Donation of a variety of toys for children of all ages under 15.
03/07/22	Health Services/Central Office	-	45,476.94	BioRidge Pharma, LLC	Donation for the Engineering Club and students education needs.
	Total donations	\$ 3,220.00	\$ 191,760.27		

SUBJECT: Statement of Impact from George Gervin Academy

PRESENTER: Joel Garcia, Assistant Superintendent for Finance

BACKGROUND INFORMATION

George Gervin Academy intends to submit an application to the Commissioner of Education. As part of the amendment process, charter schools are required to notify any districts that are likely to be affected by the change.

Texas Education Agency guidelines require that the Statement of Impact Form be sent to each district that may be affected. Information is requested if proposed change may adversely impact a district financially or if the proposed change may impact the student enrollment of a district in a manner that impairs the district's ability to comply with a court order.

Attached is the Statement of Impact form indicating the type of amendment request that is being made.

ADMINISTRATIVE CONSIDERATIONS

George Gervin Academy intends open a facility and grade levels to be served at their new campus with an effective date of August 1, 2023. The proposed new address is 702 Cullen St., Edinburg, Texas. Grade levels to be served at the new campus are: PreK-12 and the expected maximum enrollment will be 300

The Charter School intends to submit an expansion amendment request for consideration by the commissioner of education to add geographic boundaries with an effective date of August 2023.

The proposed additional school districts are listed in the attached statement of impact.

Respond to Statement of Impact form for George Gervin Academy. The proposed change for the expansion amendments charter school is expected to impact the school district to a significant degree.

FUNDING SOURCE AND AMOUNT

N/A

RECOMMENDATION

Informational Item

CONTACT PERSON(S)

Carol G. Perez, Ed. D., Superintendent of Schools
Joel Garcia, Assistant Superintendent for Finance

STATEMENT OF IMPACT
for Expansion Amendments

George Gervin Academy
Charter School

015-802
County-District #

1) Please be advised that the charter school listed above intends to submit an expansion amendment request for consideration by the commissioner of education to **add a new campus** with an effective date of: August 2023

Proposed new address, if available: 702 Cullen St, Edinburg Texas 78541

If the campus address has not yet been secured, the planned area for the campus is listed below:

Planned area: Rio Grande Valley

Grade levels to be served at the new campus: PreK-12 Expected maximum enrollment at the new campus: 300

Please note: If the requested new campus is approved by the commissioner, the agency will notify the superintendent of the school district in which the new campus will be located once the permanent address is secured.

2) Please be advised that the charter school listed above intends to submit an expansion amendment request for consideration by the commissioner of education to **add geographic boundaries** with an effective date of: 8/2023

Proposed additional school districts: Donna ISD, Edcouch-Elsa ISD, Edinburg CISD, Hidalgo ISD, La Joya ISD, La Villa ISD, McAllen ISD, Mercedes ISD, Mission ISD, PSJA-ISD, Sharyland ISD, Valley View ISD, Weslaco ISD

-- OPTIONAL--TO BE COMPLETED BY DISTRICT SUPERINTENDENT AND/OR DISTRICT BOARD PRESIDENT

Please submit forms **electronically** to charteramendments@tea.texas.gov within two weeks of receipt.

Notwithstanding the change in district enrollment that will impact Average Daily Attendance (ADA), please provide any information you feel is relevant to the commissioner's decision-making process regarding the requested growth referenced above.

Mission Consolidated Independent School District

108-908

District Name

County-District #

1201 Bryce Drive , Mission, Texas 78572

(956) 323-5515

District Address

Phone Number

Carolina "Carol" G. Perez, Ed. D.,
Superintendent of Schools

Superintendent or Board President Name

Signature of Superintendent or Board President

239

Date Received by School District



Joel Garcia
Cc: Jonena Garcia



February 28, 2022

MISSION C.I.S.D.
MAR 08 2022
SUPT'S OFFICE

Dr. Carol G. Perez
Mission ISD
1201 Bryce Dr.
Mission, Texas 78572

Dear Dr. Perez:

This letter is to inform you that our charter school intends to submit an expansion amendment request for consideration by the commissioner of education to add a new campus:

Charter School:	George Gervin Academy
County District #:	015-802
Charter School Address:	6944 Sunbelt Dr., San Antonio, TX 78218

As part of the amendment process, charter schools are required to notify any school districts that are likely to be affected by the new campus. Please see the enclosed Statement of Impact form regarding the proposed new campus.

The enclosed form may be completed by any district that may be affected, signed by the district's superintendent or board of trustee's board president, and submitted electronically to the Texas Education Agency, Charter Schools Division at CharterAmendments@tea.texas.gov.

Sincerely,

A handwritten signature in black ink, appearing to read 'Roger Martin'.

Roger Martin
Chair of the Charter Holder Governing Body

Attachment – Statement of Impact

SUBJECT: Statement of Impact from Vanguard Academy Charter School

PRESENTER: Joel Garcia, Assistant Superintendent for Finance

BACKGROUND INFORMATION

Vanguard Academy Charter School intends to submit an amendment request to the Commissioner of Education. As part of the amendment process, charter schools are required to notify any districts that are likely to be affected by the change.

Texas Education Agency guidelines require that the Statement of Impact Form be sent to each district that may be affected. Information is requested if proposed change may adversely impact a district financially or if the proposed change may impact the student enrollment of a district in a manner that impairs the district's ability to comply with a court order.

ADMINISTRATIVE CONSIDERATIONS

Vanguard Academy Charter School intends to submit the following amendment or amendments to its open-enrollment charter for consideration by the commissioner of education: The proposed new address is 3000 N. Stewart Road, Mission, Texas 78574.

Respond to Statement of Impact from Vanguard Academy Charter School. The proposed change for the amendment to the charter school is expected to impact the school district to a significant degree.

FUNDING SOURCE AND AMOUNT

N/A

RECOMMENDATION

Informational Item

CONTACT PERSON(S)

Carol G. Perez, Ed. D., Superintendent of Schools
Joel Garcia, Assistant Superintendent for Finance

**Statement of Impact
AMENDMENT**

Vanguard Academy
Charter School

108808
County-District #

The charter school above plans to submit the following amendment or amendments to its open-enrollment charter for consideration by the commissioner of education:

1. Expand grade levels served

Currently approved grade levels: _____ Requested change: _____

2. Increase maximum enrollment

Currently approved maximum enrollment: _____ Requested change: _____

3. Add a campus

Proposed new address, if available: 3000 N. Stewart Road Mission, TX 78574

If the campus address has not yet been secured, the school districts within the currently approved geographic boundary are listed here:

4. Expand geographic boundary

The proposed new school districts/area to include are listed here:

District Staff: Check the appropriate response below:

The proposed change for the open-enrollment charter school **is not** expected to impact the school district to a significant degree.

The proposed change for the open-enrollment charter school **is** expected to have a major impact on the school district in the following manner:

Mission Consolidated Independent School District

108-908

District Name

1201 Bryce Drive , Mission, TX 78572

County-District #

(956) 323-5515

District Address

Phone Number

Signature of Board President

Gerardo Zamora

Signature of Superintendent
Carolina "Carol" G. Perez, Ed. D.,
Superintendent of Schools

Print Board President's Name

Print Superintendent's Name

Date Received by District

242



VANGUARD ACADEMY CHARTER SCHOOL

A PURPOSE IN LIFE, A REASON FOR LEARNING

February 26, 2022

Mission CISD
1201 Bryce Dr.
Mission, TX 78572-4399

Dear Superintendent and President of the Board of Trustees:

This is to inform you that the following charter school intends to submit an amendment request to the commissioner of education:

Vanguard Academy Charter School
108808
2510 South Veterans Blvd.
Edinburg, TX 78539

As part of the amendment process, charter schools are required to notify any districts that are likely to be affected by the change. The enclosed Statement of Impact form indicates the type of amendment request being made.

Specifically, Texas Education Agency guidelines require that the Statement of Impact form be sent to each district that may be affected. Information is requested if the proposed change may adversely impact a district financially or if the proposed change may impact the student enrollment of a district in a manner that impairs the district's ability to comply with a court order. The enclosed form may be completed by any district that may be affected, signed by the district's board president and superintendent, and returned to the Texas Education Agency, Charter Schools Division, 1701 North Congress Avenue, Austin, Texas 78701-1494.

Please review the enclosed form and notify the Texas Education Agency if your district will be impacted by the request.

Sincerely,

Dr. Narciso Garcia
Superintendent of Schools

Received

MAR 03 2022

BY FINANCE DEPARTMENT