

SHERRI BAKER
9037 E 40 Rd., Bon Aqua, TN 37025

PIPPA TAYLOR
6585 Oak Hill Rd., Lyles, TN 37098

TIM HOBBS
9220 Old Bon Aqua Rd., Bon Aqua, TN 37025

TABITHA CUDE
4141 Lewis Rd., Centerville, TN 37033



DOUG LANE
2059 Lake Dr., Centerville, TN 37033

CHRISTY MAYS
450 Hwy 50, Centerville, TN 37033

JANE HERRON
PO Box 13, Nunnely, TN 37137

John Mullins
Director of Schools
115 MURPHREE AVENUE
CENTERVILLE, TN 37033

REGULAR BOARD MEETING
Monday, October 20, 2025 6:30 PM
Hickman County High School Library

I. Call To Order

II. Public Comment

Citizens that would like an opportunity to speak to the Board of Education during public comment should sign up on the sheet provided at the meeting location. Anyone desiring to speak on any subject may speak for 3 minutes without prior school board notification. The sign-up sheet will be available from 5:30 p.m. - 6:30 p.m.

III. Moment of Silence

IV. Pledge of Allegiance

V. Agenda for October 20, 2025

VI. Regular Meeting Minutes for September 8, 2025

VII. Special Recognition

A. Employee of the Month

B. Recognition of Retiring Employees

Libby Betts - 29 yrs - Christy Mays

Tracy Blackwell - 24 yrs - Pippa Taylor

Dr. Eddie Boone - 10 yrs - Sherri Baker

Lori Cochran - 31 yrs - Dr. Tabitha Cude

Yvonne Daniel - 31 yrs - Jane Herron

Elaine Engler - 16 yrs - Tim Hobbs

Denise Graves - 23 yrs - Doug Lane

Gayle Mathis - 31 yrs - Doug Lane

Cookie Mays - 5 yrs - Christy Mays

Charles McCaleb - 10 yrs - Tim Hobbs

VIII. Consent Agenda Items

A. Board Chair's Report

1. Chair's Countersigned Warrants

B. Personnel Report

C. Financial Report

D. Attendance Report

- E. Budget Amendment #14 from September was pulled due to being a duplicate of Budget Amendment #7 from August.
- F. Textbook Compliance from Principals
- IX. Items Requiring Board Action
 - A. Trip Requests
 - 1. HCHS Beta Club Convention
 - 2. HCMS Beta Club Convention
 - 3. HCHS JROTC Raider Competition (**Request Was Rescinded Due To Government Shutdown**)
 - B. TISA Accountability Report FY26
 - C. Budget Amendments
 - D. School Year 25-26 Internal School Funds Contract
 - E. Bid Approval for EHHS CTE Agricultural/Vocational Building
 - F. Board Policies
 - 1. Revised Board Policy 4.406 (1st Reading)
 - 2. Board Policies Review - 6.504--6.709
- X. Discussion
 - A. Director of Schools Search
- XI. Announcements
 - A. Regular Board Meeting for November 3, 2025
 - B. November 13-16 --- 2025 TSBA Leadership Conference and Annual Convention
- XII. Closing Comments
 - A. Legislative Representative
 - B. Board Chair, Board Members, Student Representatives and Director of Schools
- XIII. Adjourn

DOUG LANE
2059 Lake Drive, Centerville, TN 37033

PIPPA TAYLOR
6585 Oak Hill Rd., Lyles, TN 37098

TIM HOBBS
9220 Old Bon Aqua Rd., Bon Aqua, TN 37025

TABITHA CUDE
4141 Lewis Rd., Centerville, TN 37033



John Mullins
Superintendent of Schools
115 MURPHREE AVENUE
CENTERVILLE, TN 37033

CHRISTY MAYS
450 Hwy 50, Centerville, TN 37033

SHERRI BAKER
9037 E 40 Rd., Bon Aqua, TN 37025

JANE HERRON
PO Box 13, Nunnally, TN 37137

The Hickman County Board of Education will meet in regular session on Monday, October 20, 2025, at 6:30 p.m. in the Library at Hickman County High School.

- I. Call to Order
- II. Public Comment
Citizens that would like an opportunity to speak to the Board of Education during public comment should sign up on the sheet provided at the meeting location. Anyone desiring to speak on any subject may speak for 3 minutes without prior school board notification. The sign-up sheet will be available from 5:30 p.m. - 6:30 p.m.
- III. Moment of Silence
- IV. Pledge of Allegiance
- V. Agenda for October 20, 2025
- VI. Regular Meeting Minutes for September 8, 2025
- VII. Special Recognition
 - A. Employee of the Month—Doug Lane
 - B. Recognition of Retiring Employees
Libby Betts – 29 yrs. – Christy Mays
Tracy Blackwell – 24 yrs. – Pippa Taylor
Dr. Eddie Boone – 10 yrs. – Sherri Baker
Lori Cochran – 31 yrs. – Dr. Tabitha Cude
Yvonne Daniel – 31 yrs. – Jane Herron
Elaine Engler – 16 yrs. – Tim Hobbs
Denise Graves – 23 yrs. – Doug Lane
Gayle Mathis – 31 yrs. – Doug Lane
Cookie Mays – 5 yrs. – Christy Mays
Charles McCaleb – 10 yrs. – Tim Hobbs
- VIII. Consent Agenda Items
 - A. Board Chair's Report
 1. Chair's Countersigned Warrants
 - B. Personnel Report
 - C. Financial Report
 - D. Attendance Report
 - E. Budget Amendment #14 from September was pulled due to being a duplicate of Budget Amendment #7 from August.
 - F. Textbook Compliance from Principals

- IX. Items Requiring Board Action
 - A. Trip Requests
 - 1. HCHS Beta Club Convention—Sponsor and Students
 - 2. HCMS Beta Club—Sponsor and Students
 - 3. HCHS JROTC Raider Competition—Instructor and Cadets
 - B. TISA Accountability Report FY26—Dr. Belinda Anderson
 - C. Budget Amendments—Business Officer
 - D. School Year 25-26 Internal School Funds Contract—Business Officer
 - E. Bid Approval for EHHS CTE Agricultural/Vocational Building (bids will open on 10/16/25)
 - F. Board Policies—Misty Shelton
 - 1. Revised Board Policy – 4.606 - 1st Reading—Misty Shelton
 - 2. Board Policies Review – 6.504—6.709—Misty Shelton
- X. Discussion
 - A. Director of Schools Search
- XI. Announcements
 - A. Regular Board Meeting for November 3, 2025
 - B. November 13-16---2025 TSBA Leadership Conference and Annual Convention at Opryland
- XII. Closing Comments
 - A. Legislative Representative—Christy Mays
 - B. Board Chair, Board Members, Student Representatives and Director of Schools
- XIII. Adjourn

HICKMAN COUNTY BOARD OF EDUCATION
REGULAR BOARD MEETING---September 8, 2025

The Hickman county Board of Education met on September 8, 2025, at 6:30 PM in Central Office - Room 203.

Present: Sherri Baker, Jane Herron, Tim Hobbs, Christy Mays, Pippa Taylor,
Absent: Tabitha Cude, Doug Lane.

I. Call To Order

II. Public Comment

Citizens that would like an opportunity to speak to the Board of Education during public comment should sign up on the sheet provided at the meeting location. Anyone desiring to speak on any subject may speak for 3 minutes without prior school board notification. The sign-up sheet will be available from 5:30 p.m. - 6:30 p.m.

III. Moment of Silence

IV. Pledge of Allegiance

V. Agenda for September 8, 2025

Motion to approve the agenda for September 8, 2025 with an additional non-action item.

Motion made by Jane Herron.

Motion seconded by Christy Mays.

Motion Result: Passed

Tabitha Cude: Absent

Doug Lane: Absent

Sherri Baker: Yea

Jane Herron: Yea

Tim Hobbs: Yea

Christy Mays: Yea

Pippa Taylor: Yea

Yea: 5, Nay: 0, Absent: 2

VI. Regular Meeting Minutes for August 4, 2025

Motion to approve the Regular Meeting Minutes for August 4, 2025.

Motion made by Christy Mays.

Motion seconded by Pippa Taylor.

Motion Result: Passed

Tabitha Cude: Absent

Doug Lane: Absent

Sherri Baker: Yea

Jane Herron: Yea

Tim Hobbs: Yea

Christy Mays: Yea

Pippa Taylor: Yea

Yea: 5, Nay: 0, Absent: 2

VII. Special Recognition

HICKMAN COUNTY BOARD OF EDUCATION
REGULAR BOARD MEETING---September 8, 2025

A. Employee of the Month

VIII. Consent Agenda Items

Motion to approve the Consent Agenda Items.

Motion made by Christy Mays.

Motion seconded by Jane Herron.

Motion Result: Passed

Tabitha Cude: Absent

Doug Lane: Absent

Sherri Baker: Yea

Jane Herron: Yea

Tim Hobbs: Yea

Christy Mays: Yea

Pippa Taylor: Yea

Yea: 5, Nay: 0, Absent: 2

A. Board Chair's Report

1. Chair's Countersigned Warrants

B. Personnel Report

C. Financial Report

D. Attendance Report

IX. Informational Items Requiring No Board Action

A. Strategic Plan

Working session dates will be emailed that would work for everyone. OPEB can be included.

B. OPEB

C. EHHS Financial Donation from Apex Bank

D. Review Board Policy 1.806

E. District Enrollment

X. Items Requiring Board Action

A. Trip Requests

1. EHHS National Conference for Student Journalism

Motion to approve EHHS National Conference for Student Journalism in Nashville, TN.

Motion made by Christy Mays.

Motion seconded by Pippa Taylor.

Motion Result: Passed

Tabitha Cude: Absent

Doug Lane: Absent

Sherri Baker: Yea

Jane Herron: Yea

Tim Hobbs: Yea

Christy Mays: Yea

HICKMAN COUNTY BOARD OF EDUCATION
REGULAR BOARD MEETING---September 8, 2025

Pippa Taylor: Yea
Yea: 5, Nay: 0, Absent: 2

2. HCHS JROTC Raider Competition - September 2025
Motion to approve HCHS JROTC Raider Competition - September 2025.
Motion made by Jane Herron.
Motion seconded by Pippa Taylor.
Motion Result: Passed

Tabitha Cude: Absent
Doug Lane: Absent
Sherri Baker: Yea
Jane Herron: Yea
Tim Hobbs: Yea
Christy Mays: Yea
Pippa Taylor: Yea
Yea: 5, Nay: 0, Absent: 2

3. HCHS JROTC Raider Competition - October 2025
Motion to approve HCHS JROTC Raider Competition - October 2025.
Motion made by Christy Mays.
Motion seconded by Pippa Taylor.
Motion Result: Passed

Tabitha Cude: Absent
Doug Lane: Absent
Sherri Baker: Yea
Jane Herron: Yea
Tim Hobbs: Yea
Christy Mays: Yea
Pippa Taylor: Yea
Yea: 5, Nay: 0, Absent: 2

B. EHHS Equestrian Club "Future Vets United"
Motion to approve EHHS Equestrian Club "Future Vets United".
Motion made by Jane Herron.
Motion seconded by Pippa Taylor.
Motion Result: Passed

Tabitha Cude: Absent
Doug Lane: Absent
Sherri Baker: Yea
Jane Herron: Yea
Tim Hobbs: Yea
Christy Mays: Yea
Pippa Taylor: Yea
Yea: 5, Nay: 0, Absent: 2

C. Approve KBJM Architect Contract for EHHS Roof

HICKMAN COUNTY BOARD OF EDUCATION
REGULAR BOARD MEETING---September 8, 2025

Motion to approve KBJM Architect Contract for EHHS Roof.

Motion made by Christy Mays.

Motion seconded by Jane Herron.

Motion Result: Passed

Tabitha Cude: Absent

Doug Lane: Absent

Sherri Baker: Yea

Jane Herron: Yea

Tim Hobbs: Yea

Christy Mays: Yea

Pippa Taylor: Yea

Yea: 5, Nay: 0, Absent: 2

D. HCHS Classroom Renovation Change Order

Motion to approve HCHS Classroom Renovation Change Order.

Motion made by Christy Mays.

Motion seconded by Pippa Taylor.

Motion Result: Passed

Tabitha Cude: Absent

Doug Lane: Absent

Sherri Baker: Yea

Jane Herron: Yea

Tim Hobbs: Yea

Christy Mays: Yea

Pippa Taylor: Yea

Yea: 5, Nay: 0, Absent: 2

E. Budget Amendments

Motion to approve budget amendments 10, 11, 12, 13, and 14.

Motion made by Jane Herron.

Motion seconded by Christy Mays.

Motion Result: Passed

Tabitha Cude: Absent

Doug Lane: Absent

Sherri Baker: Yea

Jane Herron: Yea

Tim Hobbs: Yea

Christy Mays: Yea

Pippa Taylor: Yea

Yea: 5, Nay: 0, Absent: 2

F. Board Policies

1. Revised Board Policy 6.200 - 1st Reading

Motion to revise Board Policy 6.200 as presented - waived 2nd reading.

Motion made by Jane Herron.

Motion seconded by Tim Hobbs.

Motion Result: Passed

HICKMAN COUNTY BOARD OF EDUCATION
REGULAR BOARD MEETING---September 8, 2025

Tabitha Cude: Absent
Doug Lane: Absent
Sherri Baker: Yea
Jane Herron: Yea
Tim Hobbs: Yea
Christy Mays: Yea
Pippa Taylor: Yea
Yea: 5, Nay: 0, Absent: 2

2. Board Policies Review 6.4081--6.503
Motion to review board policies 6.4081-6.503.
Motion made by Christy Mays.
Motion seconded by Pippa Taylor.
Motion Result: Passed

Tabitha Cude: Absent
Doug Lane: Absent
Sherri Baker: Yea
Jane Herron: Yea
Tim Hobbs: Yea
Christy Mays: Yea
Pippa Taylor: Yea
Yea: 5, Nay: 0, Absent: 2

G. Approve Amended Contract with Lyle, Cook, Martin Architects for Services
Rendered in Conjunction with the HCHS Consumer Science Classroom
Renovation.

Motion to Approve Amended Contract with Lyle, Cook, Martin Architects for
Services Rendered in Conjunction with the HCHS Consumer Science Classroom
Renovation.

Motion made by Tim Hobbs.
Motion seconded by Jane Herron.
Motion Result: Passed

Tabitha Cude: Absent
Doug Lane: Absent
Sherri Baker: Yea
Jane Herron: Yea
Tim Hobbs: Yea
Christy Mays: Yea
Pippa Taylor: Yea
Yea: 5, Nay: 0, Absent: 2

XI. Board Policy 1.200 - Method of Election of Officers

XII. Board Officer Elections 2025-2026

A. Chair

Tim Hobbs nominated Chair.

Motion made by Jane Herron.

HICKMAN COUNTY BOARD OF EDUCATION
REGULAR BOARD MEETING---September 8, 2025

Motion seconded by Christy Mays.

Motion Result: Passed

Tabitha Cude: Absent
Doug Lane: Absent
Sherri Baker: Yea
Jane Herron: Yea
Tim Hobbs: Yea
Christy Mays: Yea
Pippa Taylor: Yea
Yea: 5, Nay: 0, Absent: 2

B. Vice Chair

Doug Lane is vice chair.

Motion made by Jane Herron.

Motion seconded by Christy Mays.

Motion Result: Passed

Tabitha Cude: Absent
Doug Lane: Absent
Sherri Baker: Yea
Jane Herron: Yea
Tim Hobbs: Yea
Christy Mays: Yea
Pippa Taylor: Yea
Yea: 5, Nay: 0, Absent: 2

C. Pro-Tem

Jane Herron made Pro-Tem.

Motion made by Sherri Baker.

Motion seconded by Tim Hobbs.

Motion Result: Passed

Tabitha Cude: Absent
Doug Lane: Absent
Sherri Baker: Yea
Jane Herron: Yea
Tim Hobbs: Yea
Christy Mays: Yea
Pippa Taylor: Yea
Yea: 5, Nay: 0, Absent: 2

D. Legislative Representative

Christy Mays legislative representative.

Motion made by Pippa Taylor.

Motion seconded by Sherri Baker.

Motion Result: Passed

Tabitha Cude: Absent
Doug Lane: Absent

HICKMAN COUNTY BOARD OF EDUCATION
REGULAR BOARD MEETING---September 8, 2025

Sherri Baker: Yea
Jane Herron: Yea
Tim Hobbs: Yea
Christy Mays: Yea
Pippa Taylor: Yea
Yea: 5, Nay: 0, Absent: 2

E. Student Representatives' Mentors Assigned by Chair
Mentors assigned by chair (Emily Kuhn, EHHS; Kitty Bates, HCHS) Sherri Baker will be mentoring.

Motion made by Tim Hobbs.
Motion seconded by Sherri Baker.
Motion Result: Passed

Tabitha Cude: Absent
Doug Lane: Absent
Sherri Baker: Yea
Jane Herron: Yea
Tim Hobbs: Yea
Christy Mays: Yea
Pippa Taylor: Yea
Yea: 5, Nay: 0, Absent: 2

XIII. Announcements

A. Regular Board Meeting for October 20, 2025 (location - HCHS Library due to retiree awards)

XIV. Closing Comments

- A. Legislative Representative
- B. Board Chair, Board Members and Director of Schools

XV. Adjourn

Motion to adjourn meeting.
Motion made by Christy Mays.
Motion seconded by Jane Herron.
Motion Result: Passed

Tabitha Cude: Absent
Doug Lane: Absent
Sherri Baker: Yea
Jane Herron: Yea
Tim Hobbs: Yea
Christy Mays: Yea
Pippa Taylor: Yea
Yea: 5, Nay: 0, Absent: 2

Hickman County Finance
Payment Register By Account Control

Bank Name Bank Number
General Purpose 141

<u>Payment Number</u>	<u>Vendor Name</u>	<u>Vendor ID</u>	<u>Payment Date</u>	<u>Cash Account</u>	<u>Amount</u>
41003513	Amazon	727	09/04/2025	141- -11140	\$2,463.40
41003514	American Stripers, LLC	8888	09/04/2025	141- -11140	\$800.00
41003515	Anderson, Belinda	8051	09/04/2025	141- -11140	\$347.34
41003516	B & E Electronics, Inc.	856	09/04/2025	141- -11140	\$7,844.87
41003517	Bon Aqua Lyles Utility Distric	851	09/04/2025	141- -11140	\$3,024.15
41003518	Bowman, Amanda	964	09/04/2025	141- -11140	\$37.15
41003519	Brewer, Robert G.	7665	09/04/2025	141- -11140	\$224.00
41003520	County Of Hickman Misc Acct	1633	09/04/2025	141- -11140	\$242,864.89
41003521	Cross, Emily	1744	09/04/2025	141- -11140	\$212.80
41003522	Dunlap, Marcus	8955	09/04/2025	141- -11140	\$94.27
41003523	East Hickman High School	2113	09/04/2025	141- -11140	\$10,000.00
41003524	East Hickman Middle School	2097	09/04/2025	141- -11140	\$7,500.00
41003525	Evans, Meghan	987	09/04/2025	141- -11140	\$215.60
41003526	Frazier, Lena	186	09/04/2025	141- -11140	\$37.15
41003527	Gallaher & Associates, Inc.	7285	09/04/2025	141- -11140	\$5,858.41
41003528	Gilbert, Brad L	156	09/04/2025	141- -11140	\$37.15
41003529	Harvill, Nancy	2758	09/04/2025	141- -11140	\$7,350.00
41003530	Hickman County High School	2917	09/04/2025	141- -11140	\$10,000.00
41003531	Hickman County Middle School	2957	09/04/2025	141- -11140	\$5,000.00
41003532	Anderson, Lynne	8643	09/04/2025	141- -11140	\$162.40
41003533	Matrix Mechanical Solutions, LLC	7974	09/04/2025	141- -11140	\$5,730.00
41003534	McManus, Christy	8120	09/04/2025	141- -11140	\$358.82
41003535	Meriwether Lewis Electric Coop.	3694	09/04/2025	141- -11140	\$66,471.39
41003536	Monica Ogles PT	7756	09/04/2025	141- -11140	\$3,581.00
41003537	Oriental Trading Co., Inc.	6258	09/04/2025	141- -11140	\$495.86
41003538	Plunkett, Shelia	8956	09/04/2025	141- -11140	\$37.15
41003539	Quill, LLC	4574	09/04/2025	141- -11140	\$970.77
41003540	Roman A/V, LLC.	7045	09/04/2025	141- -11140	\$700.00
41003541	Saleh, Lonnie D.	8957	09/04/2025	141- -11140	\$37.15
41003542	Warren, Shelby	8530	09/04/2025	141- -11140	\$120.00
41003543	Soliant Health, LLC	8569	09/04/2025	141- -11140	\$2,091.75
41003544	Herrera, Tammy	8538	09/04/2025	141- -11140	\$39.20
41003545	Tennessee School Board Assoc.	61	09/04/2025	141- -11140	\$450.00
41003546	The King's Daughter's School	7928	09/04/2025	141- -11140	\$5,250.00
41003547	Town Of Centerville	5315	09/04/2025	141- -11140	\$325.86
41003548	Vista Higher Learning	8476	09/04/2025	141- -11140	\$1,051.82
41003549	Whitaker, Wesley	7554	09/04/2025	141- -11140	\$224.00

check was wrong amount

141 Total: \$392,008.35

Bank Total: \$392,008.35

Bank Payment Count: 37

Hickman County Finance
Payment Register By Account Control

Bank Name **Bank Number**
Federal 142

<u>Payment Number</u>	<u>Vendor Name</u>	<u>Vendor ID</u>	<u>Payment Date</u>	<u>Cash Account</u>	<u>Amount</u>
42000878	County Of Hickman Misc Acct	1633	09/04/2025	142-010-11140	\$399.81
42000880	Mayberry, Kimberly D.	4108	09/04/2025	142-010-11140	\$169.19
142-010 Total:					\$569.00
42000878	County Of Hickman Misc Acct	1633	09/04/2025	142-101-11140	\$2,443.30
142-101 Total:					\$2,443.30
42000878	County Of Hickman Misc Acct	1633	09/04/2025	142-170-11140	\$367.36
142-170 Total:					\$367.36
42000878	County Of Hickman Misc Acct	1633	09/04/2025	142-201-11140	\$303.60
42000879	Hudgins, Jennifer Thrasher	3019	09/04/2025	142-201-11140	\$98.00
142-201 Total:					\$401.60
42000878	County Of Hickman Misc Acct	1633	09/04/2025	142-601-11140	\$118.51
142-601 Total:					\$118.51
42000878	County Of Hickman Misc Acct	1633	09/04/2025	142-801-11140	\$36.00
142-801 Total:					\$36.00
42000878	County Of Hickman Misc Acct	1633	09/04/2025	142-901-11140	\$1,245.88
142-901 Total:					\$1,245.88
Bank Total:					\$5,181.65
Bank Payment Count:					3

Date/Time: 9/4/2025 12:30 PM

Hickman County Finance
Payment Register By Account Control

User:

Misty Weems
Page 1 of 1

Bank Name Bank Number
Cafeteria 143

<u>Payment Number</u>	<u>Vendor Name</u>	<u>Vendor ID</u>	<u>Payment Date</u>	<u>Cash Account</u>	<u>Amount</u>
43000608	County Of Hickman Misc Acct	1633	09/04/2025	143- -11140	\$10,177.98
43000609	Town Of Centerville	5315	09/04/2025	143- -11140	\$80.11
143 Total:					\$10,258.09
Bank Total:					\$10,258.09
Bank Payment Count:					2

Hickman County Finance
Payment Register By Account Control

Bank Name Bank Number
General Purpose 141

<u>Payment Number</u>	<u>Vendor Name</u>	<u>Vendor ID</u>	<u>Payment Date</u>	<u>Cash Account</u>	<u>Amount</u>
41003550	A Dirty Job	665	09/08/2025	141- -11140	\$2,100.00
41003551	Ace Hardware	635	09/08/2025	141- -11140	\$637.32
41003552	Advantage Lock & Key	6860	09/08/2025	141- -11140	\$435.50
41003553	Allegra Print & Imaging	650	09/08/2025	141- -11140	\$15.50
41003554	AT & T	7542	09/08/2025	141- -11140	\$240.08
41003555	Bennett & DeCamp PLLC	8071	09/08/2025	141- -11140	\$731.00
41003556	Brewer Chemicals & Equip, LLC	861	09/08/2025	141- -11140	\$420.00
41003557	Central States Bus Sales, Inc.	1326	09/08/2025	141- -11140	\$3,819.06
41003558	Ed's Supply, Inc.	2103	09/08/2025	141- -11140	\$2,665.71
41003559	Frost Environmental Services, LLC	2350	09/08/2025	141- -11140	\$2,000.00
41003560	Gross, Debbie	2675	09/08/2025	141- -11140	\$127.05
41003561	Hickman County Trustee	2937	09/08/2025	141- -11140	\$4,097.44
41003562	Lakeshore Learning	3463	09/08/2025	141- -11140	\$488.92
41003563	McCaleb, Rachel	7746	09/08/2025	141- -11140	\$60.20
41003564	Meriwether Lewis Electric	3675	09/08/2025	141- -11140	\$65,471.39
41003565	NCS Pearson Inc.	4359	09/08/2025	141- -11140	\$15,190.00
41003566	O'Reilly Auto Parts	4265	09/08/2025	141- -11140	\$1,788.02
41003567	Plumbmaster, Inc.	4379	09/08/2025	141- -11140	\$11.99
41003568	Soliant Health, LLC	8569	09/08/2025	141- -11140	\$2,091.75
41003569	State Of Tn Dept Of Labor	4824	09/08/2025	141- -11140	\$55.00
41003570	State Systems, LLC	5242	09/08/2025	141- -11140	\$505.00
41003571	Tanner, Katelyn	6315	09/08/2025	141- -11140	\$53.90
41003572	United Farm & Home Co-op	2769	09/08/2025	141- -11140	\$11.98

Corrected check ———

141 Total: \$103,016.81

Bank Total: \$103,016.81

Bank Payment Count: 23

<u>Bank Name</u>	<u>Bank Number</u>					<u>Amount</u>
Federal	142					
<u>Payment Number</u>	<u>Vendor Name</u>	<u>Vendor ID</u>	<u>Payment Date</u>	<u>Cash Account</u>		
42000882	Thomasson, Julia	192	09/08/2025	142-010-11140		\$400.40
					142-010 Total:	\$400.40
42000881	Apple, Inc.	774	09/08/2025	142-901-11140		\$1,716.00
42000883	Wilson, Anita	7954	09/08/2025	142-901-11140		\$840.00
					142-901 Total:	\$2,556.00
					Bank Total:	\$2,956.40
					Bank Payment Count:	3

Date/Time: 9/10/2025 9:55 AM

Hickman County Finance
Payment Register By Account Control

User:

Misty Weems
Page 1 of 1

<u>Bank Name</u>	<u>Bank Number</u>
General Purpose	141

<u>Payment Number</u>	<u>Vendor Name</u>	<u>Vendor ID</u>	<u>Payment Date</u>	<u>Cash Account</u>	<u>Amount</u>
41003573	Hickman County Trustee	2937	09/10/2025	141- -11140	\$184,364.18
141 Total:					\$184,364.18
Bank Total:					\$184,364.18
Bank Payment Count:					1

Hickman County Finance
Payment Register By Account Control

Bank Name Bank Number
Cafeteria 143

<u>Payment Number</u>	<u>Vendor Name</u>	<u>Vendor ID</u>	<u>Payment Date</u>	<u>Cash Account</u>	<u>Amount</u>
43000610	Fesco	2399	09/11/2025	143- -11140	\$745.50
43000611	Fitts, Connie S.	185	09/11/2025	143- -11140	\$109.90
43000612	Gordon Food Service, Inc.	2488	09/11/2025	143- -11140	\$146,174.26
43000613	Hobart Service, LLC	2740	09/11/2025	143- -11140	\$1,718.47
43000614	Ivey Mechanical Company. LLC	8795	09/11/2025	143- -11140	\$1,494.86
43000615	Murfreesboro Pure Milk Co, Inc.	7552	09/11/2025	143- -11140	\$3,165.60
43000616	Optimus Pest Solutions	47	09/11/2025	143- -11140	\$240.00
43000617	Pepsi Cola	6726	09/11/2025	143- -11140	\$3,381.60
43000618	Petrowski, Jera	4345	09/11/2025	143- -11140	\$132.30
43000619	Postmaster	4334	09/11/2025	143- -11140	\$390.00
43000620	Prairie Farms Dairy	18	09/11/2025	143- -11140	\$18,252.39
43000621	Volco	5841	09/11/2025	143- -11140	\$5,958.44

143 Total: \$181,763.32

Bank Total: \$181,763.32

Bank Payment Count: 12

Check voided

Hickman County Finance
Payment Register By Account Control

Bank Name Bank Number
General Purpose 141

<u>Payment Number</u>	<u>Vendor Name</u>	<u>Vendor ID</u>	<u>Payment Date</u>	<u>Cash Account</u>	<u>Amount</u>
41003574	Amazon	727	09/11/2025	141- -11140	\$3,889.23
41003575	BAM Flooring, Inc.	6578	09/11/2025	141- -11140	\$1,750.00
41003576	Dickson Medical Associates	2022	09/11/2025	141- -11140	\$125.00
41003577	Duley, L.C.S.W., Joe	1814	09/11/2025	141- -11140	\$2,015.00
41003578	Ferrellgas	7446	09/11/2025	141- -11140	\$651.90
41003579	Gallopade	8335	09/11/2025	141- -11140	\$329.78
41003580	Hickman Co Trustee	2722	09/11/2025	141- -11140	\$252,406.85
41003581	Jenkins, Michelle Carol	7423	09/11/2025	141- -11140	\$95.20
41003582	Karco Parts	3364	09/11/2025	141- -11140	\$57.92
41003583	Kelsan, Inc.	3379	09/11/2025	141- -11140	\$4,176.46
41003584	Main Street Emporium	7541	09/11/2025	141- -11140	\$20.75
41003585	Optimus Pest Solutions	47	09/11/2025	141- -11140	\$750.00
41003586	Porter, Savannah	8555	09/11/2025	141- -11140	\$120.00
41003587	Sanorbix, LLC	8529	09/11/2025	141- -11140	\$7,164.25
41003588	Stellar Therapy Services, LLC	8260	09/11/2025	141- -11140	\$7,770.00
41003589	Tennessee Book Company	5286	09/11/2025	141- -11140	\$1,511.00
41003590	The Brook Center Therapy Solutions, LLC	8659	09/11/2025	141- -11140	\$1,335.00
41003591	Therapy Shoppe, Inc.	5320	09/11/2025	141- -11140	\$571.78
41003592	Town Of Centerville	5315	09/11/2025	141- -11140	\$11,484.64
41003593	Unifirst Corp.	5758	09/11/2025	141- -11140	\$649.52
41003594	UPS	8274	09/11/2025	141- -11140	\$40.41
41003595	Verizon Wireless	5823	09/11/2025	141- -11140	\$68.04
41003596	Visa	8268	09/11/2025	141- -11140	\$39.12
41003597	Weber, Jenny	8968	09/11/2025	141- -11140	\$37.15
141 Total:					\$297,059.00
Bank Total:					\$297,059.00
Bank Payment Count:					24

Bank Name Bank Number
 Federal 142

<u>Payment Number</u>	<u>Vendor Name</u>	<u>Vendor ID</u>	<u>Payment Date</u>	<u>Cash Account</u>	<u>Amount</u>
42000885	Hickman Co Trustee	2722	09/11/2025	142-010-11140	\$150.20
142-010 Total:					\$150.20
42000885	Hickman Co Trustee	2722	09/11/2025	142-101-11140	\$1,231.05
142-101 Total:					\$1,231.05
42000885	Hickman Co Trustee	2722	09/11/2025	142-170-11140	\$82.70
142-170 Total:					\$82.70
42000885	Hickman Co Trustee	2722	09/11/2025	142-201-11140	\$150.20
142-201 Total:					\$150.20
42000884	Amazon	727	09/11/2025	142-801-11140	\$1,216.04
42000885	Hickman Co Trustee	2722	09/11/2025	142-801-11140	\$82.70
142-801 Total:					\$1,298.74
42000885	Hickman Co Trustee	2722	09/11/2025	142-901-11140	\$1,677.50
142-901 Total:					\$1,677.50
42000885	Hickman Co Trustee	2722	09/11/2025	142-911-11140	\$82.70
142-911 Total:					\$82.70
Bank Total:					\$4,673.09
Bank Payment Count:					2

Hickman County Finance
 Payment Register By Account Control

Bank Name Bank Number
 General Purpose 141

<u>Payment Number</u>	<u>Vendor Name</u>	<u>Vendor ID</u>	<u>Payment Date</u>	<u>Cash Account</u>	<u>Amount</u>
41003598	Amazon	727	09/18/2025	141- -11140	\$273.46
41003599	AT & T	7542	09/18/2025	141- -11140	\$202.82
41003600	Bates, Michelle	889	09/18/2025	141- -11140	\$154.00
41003601	County Of Hickman Misc Acct	1633	09/18/2025	141- -11140	\$6,869.56
41003602	Dickson Electric System	1806	09/18/2025	141- -11140	\$47,237.29
41003603	Dotson, Cecily	1895	09/18/2025	141- -11140	\$72.80
41003604	Grover, Maria E.	8036	09/18/2025	141- -11140	\$37.15
41003605	Kelsan, Inc.	3379	09/18/2025	141- -11140	\$4,018.93
41003606	Lyle-Cook-Martin	7919	09/18/2025	141- -11140	\$33,407.99
41003607	Mccaleb, Susan	4081	09/18/2025	141- -11140	\$37.15
41003608	NCS Pearson Inc.	4359	09/18/2025	141- -11140	\$158.00
41003609	Rj Young Company	4691	09/18/2025	141- -11140	\$8,542.23
41003610	Sam's Club MC/SYNCB	4828	09/18/2025	141- -11140	\$545.09
41003611	Soliant Health, LLC	8569	09/18/2025	141- -11140	\$1,673.40
41003612	Tennessee Bureau Of Investigation	5491	09/18/2025	141- -11140	\$800.00
41003613	Town Of Centerville	5315	09/18/2025	141- -11140	\$4,012.26
41003614	Zayo Education	2141	09/18/2025	141- -11140	\$2,056.63
141 Total:					\$110,098.76
Bank Total:					\$110,098.76
Bank Payment Count:					17

Hickman County Finance
 Payment Register By Account Control

Bank Name Bank Number
 Federal 142

<u>Payment Number</u>	<u>Vendor Name</u>	<u>Vendor ID</u>	<u>Payment Date</u>	<u>Cash Account</u>	<u>Amount</u>	
42000892	Rj Young Company	4691	09/18/2025	142-010-11140	\$250.00	
					142-010 Total:	\$250.00
42000892	Rj Young Company	4691	09/18/2025	142-101-11140	\$190.54	
					142-101 Total:	\$190.54
42000888	Tanner, Faith	8977	09/18/2025	142-201-11140	\$133.90	
					142-201 Total:	\$133.90
42000890	National Center For Youth Issues, Inc.	4134	09/18/2025	142-401-11140	\$235.00	
42000891	Navigate 360 LLC	8132	09/18/2025	142-401-11140	\$6,505.19	
					142-401 Total:	\$6,740.19
42000886	Amazon	727	09/18/2025	142-801-11140	\$1,107.88	
42000887	England, Miranda	8975	09/18/2025	142-801-11140	\$484.73	
42000889	Carter, Hailey	8976	09/18/2025	142-801-11140	\$510.35	
					142-801 Total:	\$2,102.96
					Bank Total:	\$9,417.59
					Bank Payment Count:	7

<u>Bank Name</u>	<u>Bank Number</u>
Cafeteria	143

<u>Payment Number</u>	<u>Vendor Name</u>	<u>Vendor ID</u>	<u>Payment Date</u>	<u>Cash Account</u>	<u>Amount</u>
43000622	Rj Young Company	4691	09/18/2025	143- -11140	\$335.50
43000623	Volco	5841	09/18/2025	143- -11140	\$1,217.04
143 Total:					\$1,552.54
Bank Total:					\$1,552.54
Bank Payment Count:					2

Bank Name Bank Number
 General Purpose 141

<u>Payment Number</u>	<u>Vendor Name</u>	<u>Vendor ID</u>	<u>Payment Date</u>	<u>Cash Account</u>	<u>Amount</u>
41003615	Amazon	727	09/22/2025	141- -11140	\$39.28
41003616	AT & T	7542	09/22/2025	141- -11140	\$2,129.42
41003617	Austin Peay State University	6864	09/22/2025	141- -11140	\$13,073.00
41003618	Dunlap, Marcus	8955	09/22/2025	141- -11140	\$49.14
41003619	Gordon, Gavin	2676	09/22/2025	141- -11140	\$155.00
41003620	Hickman County High School	2917	09/22/2025	141- -11140	\$3,650.00
41003621	Interpreters Unlimited, Inc.	6501	09/22/2025	141- -11140	\$273.75
41003622	Raptor Technologies, LLC	6690	09/22/2025	141- -11140	\$5,560.00
41003623	Republic Service, LLC #840	4739	09/22/2025	141- -11140	\$4,469.54
41003624	Save A Lot	4820	09/22/2025	141- -11140	\$59.96
41003625	Savvas Learning Company LLC	7209	09/22/2025	141- -11140	\$2,460.00
41003626	Skyward Accounting Dept	5111	09/22/2025	141- -11140	\$13,526.30
41003627	Smith, Kimberly	5251	09/22/2025	141- -11140	\$37.15
41003628	Soliant Health, LLC	8569	09/22/2025	141- -11140	\$2,091.75
41003629	UPS	8274	09/22/2025	141- -11140	\$25.00
41003630	Water Authority Of Dickson Co.	5874	09/22/2025	141- -11140	\$5,189.68
41003631	Youth Town of Tennessee, Inc.	6951	09/22/2025	141- -11140	\$1,140.00
141 Total:					\$53,928.97
Bank Total:					\$53,928.97
Bank Payment Count:					17

Hickman County Finance
 Payment Register By Account Control

Bank Name **Bank Number**
 General Purpose 141

<u>Payment Number</u>	<u>Vendor Name</u>	<u>Vendor ID</u>	<u>Payment Date</u>	<u>Cash Account</u>	<u>Amount</u>
41003632	Allegra Print & Imaging	650	09/25/2025	141- -11140	\$1,010.18
41003633	Amazon	727	09/25/2025	141- -11140	\$716.80
41003634	Baker, Sherri	7798	09/25/2025	141- -11140	\$90.30
41003635	Central Technologies, Inc.	1668	09/25/2025	141- -11140	\$2,547.00
41003636	Gordon Food Service, Inc.	2488	09/25/2025	141- -11140	\$643.93
41003637	Hickman Co Trustee	2722	09/25/2025	141- -11140	\$1,666.70
41003638	Matrix Mechanical Solutions, LLC	7974	09/25/2025	141- -11140	\$7,497.84
41003639	Montgomery, Mike	3932	09/25/2025	141- -11140	\$39.90
41003640	Owen's Oil Co., Inc.	4257	09/25/2025	141- -11140	\$25,872.70
41003641	Tays, Christopher Scott	5545	09/25/2025	141- -11140	\$37.15
141 Total:					\$40,122.50
Bank Total:					\$40,122.50
Bank Payment Count:					10

<u>Bank Name</u>	<u>Bank Number</u>
Cafeteria	143

<u>Payment Number</u>	<u>Vendor Name</u>	<u>Vendor ID</u>	<u>Payment Date</u>	<u>Cash Account</u>	<u>Amount</u>
43000624	Overby, Lori	8980	09/25/2025	143- -11140	\$37.15
43000625	Prince Hardware, LLC	4321	09/25/2025	143- -11140	\$450.91
143 Total:					\$488.06
Bank Total:					\$488.06
Bank Payment Count:					2

Bank Name **Bank Number**
 Federal 142

<u>Payment Number</u>	<u>Vendor Name</u>	<u>Vendor ID</u>	<u>Payment Date</u>	<u>Cash Account</u>	<u>Amount</u>
42000895	Hickman Co Times	2718	09/25/2025	142-010-11140	\$34.00
142-010 Total:					\$34.00
42000896	Renaissance Learning	4608	09/25/2025	142-101-11140	\$3,405.25
142-101 Total:					\$3,405.25
42000893	Amazon	727	09/25/2025	142-401-11140	\$830.92
142-401 Total:					\$830.92
42000894	Hickman Co Board Of Ed.	2734	09/25/2025	142-801-11140	\$2,039.98
142-801 Total:					\$2,039.98
42000893	Amazon	727	09/25/2025	142-901-11140	\$55.57
142-901 Total:					\$55.57
Bank Total:					\$6,365.72
Bank Payment Count:					4

Hickman County Finance
 Payment Register By Account Control

Bank Name Bank Number
 General Purpose 141

<u>Payment Number</u>	<u>Vendor Name</u>	<u>Vendor ID</u>	<u>Payment Date</u>	<u>Cash Account</u>	<u>Amount</u>
41003642	Air Med Care Network	8379	09/29/2025	141- -11140	\$3,336.79
41003643	Amazon	727	09/29/2025	141- -11140	\$2,999.95
41003644	Anderson, Belinda	8051	09/29/2025	141- -11140	\$329.70
41003645	Apple, Inc.	774	09/29/2025	141- -11140	\$2,496.00
41003646	ASMS, LLC	646	09/29/2025	141- -11140	\$859.00
41003647	AT & T	7542	09/29/2025	141- -11140	\$65.42
41003648	Chef's Deal Restaurant And Equipment Co.	1794	09/29/2025	141- -11140	\$1,870.00
41003649	E3 Diagnostics	6717	09/29/2025	141- -11140	\$1,297.00
41003650	Ferrellgas	7446	09/29/2025	141- -11140	\$4,568.80
41003651	Hickman Co Trustee	2722	09/29/2025	141- -11140	\$900.00
41003652	Hickman County Trustee	2937	09/29/2025	141- -11140	\$400,241.10
41003653	Matrix Mechanical Solutions, LLC	7974	09/29/2025	141- -11140	\$5,052.10
41003654	Mays, James	4065	09/29/2025	141- -11140	\$37.15
41003655	Metropolitan Life	3677	09/29/2025	141- -11140	\$120.00
41003656	Pace Analytical National	2230	09/29/2025	141- -11140	\$710.20
41003657	Soliant Health, LLC	8569	09/29/2025	141- -11140	\$1,924.41
41003658	Tennessee Child Support Recepting Unit	1312	09/29/2025	141- -11140	\$791.00
41003659	Tennessee Farmers Life Insurance	5297	09/29/2025	141- -11140	\$925.00
41003660	Town Of Centerville	5315	09/29/2025	141- -11140	\$302.15
41003661	Trane U.S. Inc	5383	09/29/2025	141- -11140	\$503.21
41003662	UPS	8274	09/29/2025	141- -11140	\$130.61
141 Total:					\$429,459.59
Bank Total:					\$429,459.59
Bank Payment Count:					21

Hickman County Finance
Payment Register By Account Control

Bank Name Bank Number
Federal 142

<u>Payment Number</u>	<u>Vendor Name</u>	<u>Vendor ID</u>	<u>Payment Date</u>	<u>Cash Account</u>	<u>Amount</u>
42000898	Hickman County Trustee	2937	09/29/2025	142-010-11140	\$3,302.57
42000899	Mayberry, Kimberly D.	4108	09/29/2025	142-010-11140	\$319.90
142-010 Total:					\$3,622.47
42000897	Air Med Care Network	8379	09/29/2025	142-101-11140	\$406.68
42000898	Hickman County Trustee	2937	09/29/2025	142-101-11140	\$11,157.21
42000901	Starfall Education foundation	4891	09/29/2025	142-101-11140	\$355.00
142-101 Total:					\$11,918.89
42000898	Hickman County Trustee	2937	09/29/2025	142-170-11140	\$1,561.29
142-170 Total:					\$1,561.29
42000898	Hickman County Trustee	2937	09/29/2025	142-201-11140	\$1,570.51
142-201 Total:					\$1,570.51
42000898	Hickman County Trustee	2937	09/29/2025	142-601-11140	\$462.97
142-601 Total:					\$462.97
42000898	Hickman County Trustee	2937	09/29/2025	142-801-11140	\$324.32
142-801 Total:					\$324.32
42000897	Air Med Care Network	8379	09/29/2025	142-901-11140	\$65.01
42000898	Hickman County Trustee	2937	09/29/2025	142-901-11140	\$12,377.40
42000900	NCS Pearson Inc.	4359	09/29/2025	142-901-11140	\$71.40
42000902	Tennessee Farmers Life Insurance	5297	09/29/2025	142-901-11140	\$30.00
142-901 Total:					\$12,543.81
42000898	Hickman County Trustee	2937	09/29/2025	142-911-11140	\$255.92
142-911 Total:					\$255.92
Bank Total:					\$32,260.18
Bank Payment Count:					6

Hickman County Finance
Payment Register By Account Control

Bank Name Bank Number
Cafeteria 143

<u>Payment Number</u>	<u>Vendor Name</u>	<u>Vendor ID</u>	<u>Payment Date</u>	<u>Cash Account</u>	<u>Amount</u>
43000626	Air Med Care Network	8379	09/29/2025	143- -11140	\$1,395.06
43000627	American Fidelity Assurance Co	636	09/29/2025	143- -11140	\$1,474.74
43000628	Ameritas Life Insurance Corp.	7442	09/29/2025	143- -11140	\$101.30
43000629	Beam Insurance Administrators LLC	7435	09/29/2025	143- -11140	\$456.05
43000630	EMS LINQ INC.	7823	09/29/2025	143- -11140	\$10,899.86
43000631	Hickman Co Trustee	2722	09/29/2025	143- -11140	\$2,319.34
43000632	Hickman County Trustee	2937	09/29/2025	143- -11140	\$18,197.09
43000633	Mobile Fixture & Equip. Co.	3769	09/29/2025	143- -11140	\$6,759.84
43000634	Tennessee Farmers Life Insurance	5297	09/29/2025	143- -11140	\$25.00

143 Total: \$41,628.28

Bank Total: \$41,628.28

Bank Payment Count: 9

Hickman County Finance
Payment Register By Account Control

<u>Bank Name</u>	<u>Bank Number</u>
General Purpose	141

<u>Payment Number</u>	<u>Vendor Name</u>	<u>Vendor ID</u>	<u>Payment Date</u>	<u>Cash Account</u>	<u>Amount</u>
41003663	Ace Hardware	635	10/02/2025	141- -11140	\$600.08
41003664	Amazon	727	10/02/2025	141- -11140	\$336.97
41003665	Barber, Terri	1247	10/02/2025	141- -11140	\$37.15
41003666	Bennett & DeCamp PLLC	8071	10/02/2025	141- -11140	\$602.00
41003667	Bleacher & Seats.Com	1117	10/02/2025	141- -11140	\$990.00
41003668	Bon Aqua Lyles Utility Distric	851	10/02/2025	141- -11140	\$8,869.79
41003669	Brewer, Robert G.	7665	10/02/2025	141- -11140	\$224.00
41003670	Carter, David	1639	10/02/2025	141- -11140	\$448.00
41003671	Central States Bus Sales, Inc.	1326	10/02/2025	141- -11140	\$3,436.67
41003672	County Of Hickman Misc Acct	1633	10/02/2025	141- -11140	\$58,625.14
41003673	Crisis Prevention Institute	1685	10/02/2025	141- -11140	\$332.90
41003674	Cross, Emily	1744	10/02/2025	141- -11140	\$37.15
41003675	Dickson Medical Associates	2022	10/02/2025	141- -11140	\$125.00
41003676	Hermitage Hall	2916	10/02/2025	141- -11140	\$240.00
41003677	Hibbs, Polly	3038	10/02/2025	141- -11140	\$64.40
41003678	Hickman County High School	2917	10/02/2025	141- -11140	\$2,500.00
41003679	Hickman County Trustee	2937	10/02/2025	141- -11140	\$153.68
41003680	Hughes Construction Company, LLC	8981	10/02/2025	141- -11140	\$45,532.36
41003681	Jones, Alexandria	8982	10/02/2025	141- -11140	\$37.15
41003682	Lumber Yard, The	3652	10/02/2025	141- -11140	\$15.87
41003683	Lumen/Centurylink	4577	10/02/2025	141- -11140	\$80.77
41003684	Manor, Angie	4106	10/02/2025	141- -11140	\$561.40
41003685	McManus, Christy	8120	10/02/2025	141- -11140	\$361.90
41003686	Mid-South Bus Center, Inc	3706	10/02/2025	141- -11140	\$5,024.90
41003687	O'Reilly Auto Parts	4265	10/02/2025	141- -11140	\$1,589.28
41003688	Oak Plains Academy Of Tr, Inc	4292	10/02/2025	141- -11140	\$1,080.00
41003689	Prince Hardware, LLC	4321	10/02/2025	141- -11140	\$1,001.81
41003690	Rea Associates, Inc.	4655	10/02/2025	141- -11140	\$1,156.36
41003691	Sanorbix, LLC	8529	10/02/2025	141- -11140	\$17,207.00
41003692	Smith, Kimberly	5251	10/02/2025	141- -11140	\$37.15
41003693	SSC Service Solutions Compass Group USA, Inc.	4832	10/02/2025	141- -11140	\$61,838.58
41003694	The Dreaded Lawncare	7933	10/02/2025	141- -11140	\$9,000.00
41003695	Town Of Centerville	5315	10/02/2025	141- -11140	\$682.05
41003696	Trane U.S. Inc	5383	10/02/2025	141- -11140	\$883.98
41003697	Walmart	5868	10/02/2025	141- -11140	\$442.18
41003698	Whitaker, Wesley	7554	10/02/2025	141- -11140	\$212.80
141 Total:					\$224,368.47
Bank Total:					\$224,368.47
Bank Payment Count:					36

Hickman County Finance
 Payment Register By Account Control

Bank Name **Bank Number**
 Federal 142

<u>Payment Number</u>	<u>Vendor Name</u>	<u>Vendor ID</u>	<u>Payment Date</u>	<u>Cash Account</u>	<u>Amount</u>
42000904	Generations Genius, Inc.	6862	10/02/2025	142-101-11140	\$1,395.00
42000905	Tennessee Educational Technology Asso.	5371	10/02/2025	142-101-11140	\$250.00
142-101 Total:					\$1,645.00
42000905	Tennessee Educational Technology Asso.	5371	10/02/2025	142-401-11140	\$3,500.00
142-401 Total:					\$3,500.00
42000903	County Of Hickman Misc Acct	1633	10/02/2025	142-901-11140	\$212.55
142-901 Total:					\$212.55
Bank Total:					\$5,357.55
Bank Payment Count:					3

<u>Bank Name</u>	<u>Bank Number</u>
Cafeteria	143

<u>Payment Number</u>	<u>Vendor Name</u>	<u>Vendor ID</u>	<u>Payment Date</u>	<u>Cash Account</u>	<u>Amount</u>
43000635	Goins, Amy	8983	10/02/2025	143- -11140	\$37.15
43000636	Burns, Sharon	1057	10/02/2025	143- -11140	\$420.70
43000637	Fitts, Connie S.	185	10/02/2025	143- -11140	\$137.90
43000638	Petrowski, Jera	4345	10/02/2025	143- -11140	\$101.50
43000639	Prince Hardware, LLC	4321	10/02/2025	143- -11140	\$315.68
43000640	Town Of Centerville	5315	10/02/2025	143- -11140	\$130.62
143 Total:					<u>\$1,143.55</u>
Bank Total:					\$1,143.55
Bank Payment Count:					6

<u>Bank Name</u>	<u>Bank Number</u>
Cafeteria	143

<u>Payment Number</u>	<u>Vendor Name</u>	<u>Vendor ID</u>	<u>Payment Date</u>	<u>Cash Account</u>	<u>Amount</u>
43000641	County Of Hickman Misc Acct	1633	10/03/2025	143- -11140	\$10,016.97
143 Total:					\$10,016.97
Bank Total:					\$10,016.97
Bank Payment Count:					1

Bank Name Bank Number
Federal 142

<u>Payment Number</u>	<u>Vendor Name</u>	<u>Vendor ID</u>	<u>Payment Date</u>	<u>Cash Account</u>	<u>Amount</u>	
42000906	County Of Hickman Misc Acct	1633	10/03/2025	142-010-11140	\$399.81	
					142-010 Total:	\$399.81
42000906	County Of Hickman Misc Acct	1633	10/03/2025	142-101-11140	\$2,443.30	
					142-101 Total:	\$2,443.30
42000906	County Of Hickman Misc Acct	1633	10/03/2025	142-170-11140	\$303.60	
					142-170 Total:	\$303.60
42000906	County Of Hickman Misc Acct	1633	10/03/2025	142-201-11140	\$367.36	
					142-201 Total:	\$367.36
42000906	County Of Hickman Misc Acct	1633	10/03/2025	142-601-11140	\$118.51	
					142-601 Total:	\$118.51
42000906	County Of Hickman Misc Acct	1633	10/03/2025	142-801-11140	\$15.00	
					142-801 Total:	\$15.00
42000906	County Of Hickman Misc Acct	1633	10/03/2025	142-901-11140	\$1,033.33	
					142-901 Total:	\$1,033.33
					Bank Total:	\$4,680.91
					Bank Payment Count:	1

Bank Name Bank Number
General Purpose 141

<u>Payment Number</u>	<u>Vendor Name</u>	<u>Vendor ID</u>	<u>Payment Date</u>	<u>Cash Account</u>	<u>Amount</u>
41003699	County Of Hickman Misc Acct	1633	10/03/2025	141- -11140	\$233,764.57
41003700	Harvill, Nancy	2758	10/03/2025	141- -11140	\$9,838.50
41003701	Rietveid, Stephanie	993	10/03/2025	141- -11140	\$2,625.00
41003702	Town Of Centerville	5315	10/03/2025	141- -11140	\$10.50
141 Total:					<u>\$246,238.57</u>
Bank Total:					\$246,238.57
Bank Payment Count:					4

<u>Bank Name</u>	<u>Bank Number</u>
General Purpose	141

<u>Payment Number</u>	<u>Vendor Name</u>	<u>Vendor ID</u>	<u>Payment Date</u>	<u>Cash Account</u>	<u>Amount</u>
41003703	County Of Hickman Misc Acct	1633	10/07/2025	141- -11140	\$3,574.30
41003704	Hickman County Trustee	2937	10/07/2025	141- -11140	\$6,213.89
141 Total:					\$9,788.19
Bank Total:					\$9,788.19
Bank Payment Count:					2

Date/Time: 10/7/2025 9:08 AM

Hickman County Finance
Payment Register By Account Control

User:

Misty Weems
Page 1 of 1

<u>Bank Name</u>	<u>Bank Number</u>
Federal	142

<u>Payment Number</u>	<u>Vendor Name</u>	<u>Vendor ID</u>	<u>Payment Date</u>	<u>Cash Account</u>	<u>Amount</u>
42000907	County Of Hickman Misc Acct	1633	10/07/2025	142-964-11140	\$371.90
142-964 Total:					\$371.90
Bank Total:					\$371.90
Bank Payment Count:					1

Date/Time: 10/7/2025 9:11 AM

Hickman County Finance
Payment Register By Account Control

User:

Misty Weems
Page 1 of 1

<u>Bank Name</u>	<u>Bank Number</u>
Cafeteria	143

<u>Payment Number</u>	<u>Vendor Name</u>	<u>Vendor ID</u>	<u>Payment Date</u>	<u>Cash Account</u>	<u>Amount</u>
43000642	County Of Hickman Misc Acct	1633	10/07/2025	143- -11140	\$29.50
143 Total:					\$29.50
Bank Total:					\$29.50
Bank Payment Count:					1

<u>Bank Name</u>	<u>Bank Number</u>
General Purpose	141

<u>Payment Number</u>	<u>Vendor Name</u>	<u>Vendor ID</u>	<u>Payment Date</u>	<u>Cash Account</u>	<u>Amount</u>
41003705	County Of Hickman Misc Acct	1633	10/09/2025	141- -11140	\$9,322.05
141 Total:					\$9,322.05
Bank Total:					\$9,322.05
Bank Payment Count:					1

<u>Bank Name</u>	<u>Bank Number</u>
Federal	142

<u>Payment Number</u>	<u>Vendor Name</u>	<u>Vendor ID</u>	<u>Payment Date</u>	<u>Cash Account</u>	<u>Amount</u>	
42000908	Hickman Co Trustee	2722	10/14/2025	142-010-11140	\$150.20	
					142-010 Total:	\$150.20
42000908	Hickman Co Trustee	2722	10/14/2025	142-101-11140	\$1,231.05	
					142-101 Total:	\$1,231.05
42000908	Hickman Co Trustee	2722	10/14/2025	142-170-11140	\$82.70	
					142-170 Total:	\$82.70
42000908	Hickman Co Trustee	2722	10/14/2025	142-201-11140	\$150.20	
					142-201 Total:	\$150.20
42000908	Hickman Co Trustee	2722	10/14/2025	142-801-11140	\$82.70	
					142-801 Total:	\$82.70
42000908	Hickman Co Trustee	2722	10/14/2025	142-901-11140	\$1,491.30	
					142-901 Total:	\$1,491.30
42000908	Hickman Co Trustee	2722	10/14/2025	142-911-11140	\$82.70	
					142-911 Total:	\$82.70
					Bank Total:	\$3,270.85
					Bank Payment Count:	1

<u>Bank Name</u>	<u>Bank Number</u>
General Purpose	141

<u>Payment Number</u>	<u>Vendor Name</u>	<u>Vendor ID</u>	<u>Payment Date</u>	<u>Cash Account</u>	<u>Amount</u>
41003706	Hickman Co Trustee	2722	10/14/2025	141- -11140	\$249,159.81
141 Total:					\$249,159.81
Bank Total:					\$249,159.81
Bank Payment Count:					1

DOUG LANE
2059 Lake Drive, Centerville, TN 37033

PIPPA TAYLOR
6585 Oak Hill Rd., Lyles, TN 37098

TIM HOBBS
9220 Old Bon Aqua Rd., Bon Aqua, TN 37025

TABITHA CUDE
4141 Lewis Rd., Centerville, TN 37033



John Mullins
Superintendent of Schools
115 MURPHREE AVENUE
CENTERVILLE, TN 37033

CHRISTY MAYS
450 Hwy. 50, Centerville, TN 37033

SHERRI BAKER
9037 E 40 Rd., Bon Aqua, TN 37025

JANE HERRON
PO Box 13, Nunnally, TN 37137

Memorandum

To: Board Members
From: John Mullins
Date: 10/13/2025
Re: October Personnel Report

Leave of Absence

Professional

Support Staff

Hiring

Professional

Joey Chilton

ALC Teacher

Hiring

Support Staff

Jason Swaw
Katelyn Skelton
Justin Summers
Lisa Blystad
Amy Goins

Bus Driver
CES Assistant
EHIS Assistant
Food Service
Food Service

Resignation

Professional

Resignation (cont.)

Support Staff

Hillarie Barber
Shelby Tucker
Johnny Canady

EHIS Assistant
Food Service
Food Service

Retirement

Professional

Tracy Rivers

ALC Teacher

Support Staff

Transfers

Professional

Support Staff

Appointment

Professional

Support Staff

Open Positions

www.hickmank12.org

Click On Employment Opportunities

*Denotes a relationship under board policy 1.108. Applicants are qualified for the positions

Hickman County Finance
 Summary Financial Statement
 September 2025

141 General Purpose School		Year-To-Date			Month-To-Date		
Account	Description	Budget Estimate	Actual	% of Budget	Estimate Avg/Mth	Actual	% of Avg
Revenues							
40110	Current Property Tax	2,773,333.00	(152.09)	0.01%	231,111.08	(152.09)	0.07%
40120	Trustee's Collections - Prior Year	75,000.00	(18,235.00)	24.31%	6,250.00	(6,282.11)	100.51%
40125	Trustee's Collections - Bankruptcy	500.00	(17.69)	3.54%	41.67	(6.85)	16.44%
40130	Cir Clk/Clk & Master Collections-Pr Yr	40,000.00	(7,827.54)	19.57%	3,333.33	(4,649.22)	139.48%
40140	Interest And Penalty	15,000.00	(1,382.35)	9.22%	1,250.00	(636.23)	50.90%
40161	Payments In Lieu Of Taxes - T. V. A.	3,500.00	(625.78)	17.88%	291.67	(208.60)	71.52%
40162	Payments In Lieu Of Taxes-Local	6,000.00	0.00	0.00%	500.00	0.00	0.00%
40210	Local Option Sales Tax	2,975,000.00	(597,448.40)	20.08%	247,916.67	(303,415.56)	122.39%
40270	Business Tax	45,000.00	(1,909.71)	4.24%	3,750.00	(215.29)	5.74%
41110	Marriage Licenses	1,300.00	(209.00)	16.08%	108.33	(104.50)	96.46%
43570	Receipts From Individual Schools	30,000.00	(650.00)	2.17%	2,500.00	(650.00)	26.00%
43582	Community Service Fees - Adults	200.00	0.00	0.00%	16.67	0.00	0.00%
44120	Lease/Rentals/PPP	7,500.00	(420.00)	5.60%	625.00	0.00	0.00%
44170	Miscellaneous Refunds	30,000.00	(1,486.17)	4.95%	2,500.00	(1,486.17)	59.45%
44530	Sale Of Equipment	15,000.00	0.00	0.00%	1,250.00	0.00	0.00%
44560	Damages Recovered From Individuals	3,000.00	(360.00)	12.00%	250.00	(360.00)	144.00%
44570	Contributions & Gifts	20,000.00	(10,200.00)	51.00%	1,666.67	(6,200.00)	372.00%
44990	Other Local Revenues	30,000.00	0.00	0.00%	2,500.00	0.00	0.00%
46175	On-Behalf Contributions For OPEB	40,000.00	0.00	0.00%	3,333.33	0.00	0.00%
46510	Tennessee Investment in Student	25,081,234.00	(5,007,647.41)	19.97%	2,090,102.83	(2,503,823.70)	119.79%
46515	Early Childhood Education	445,000.00	(186,797.97)	41.98%	37,083.33	(186,797.97)	503.72%
46520	School Food Service	22,000.00	0.00	0.00%	1,833.33	0.00	0.00%
46550	Driver Education	10,000.00	0.00	0.00%	833.33	0.00	0.00%
46590	Other State Education Funds	818,936.60	(578,936.60)	70.69%	68,244.72	0.00	0.00%
46610	Career Ladder Program	37,500.00	0.00	0.00%	3,125.00	0.00	0.00%
46790	Other Vocational	1,543,701.67	0.00	0.00%	128,641.81	160,426.09	-124.71%
46851	State Revenue Sharing -T.V.A.	220,000.00	0.00	0.00%	18,333.33	0.00	0.00%
46990	Other State Revenues	100,000.00	(48,175.68)	48.18%	8,333.33	(24,087.84)	289.05%
47640	Rotc Reimbursement	65,000.00	0.00	0.00%	5,416.67	0.00	0.00%
49800	Transfers In	10,000.00	0.00	0.00%	833.33	0.00	0.00%
	Total Revenues	34,463,705.27	(6,462,481.39)	18.75%	2,871,975.44	(2,878,650.04)	100.23%
Expenditures							
71100	Regular Instruction Program	(17,370,800.60)	3,293,583.93	18.96%	(1,447,566.72)	1,931,739.19	133.45%
71150	Alternative Instruction Program	(317,021.00)	33,074.19	10.43%	(26,418.42)	15,256.56	57.75%
71200	Special Education Program	(3,756,396.00)	528,287.67	14.06%	(313,033.00)	276,153.53	88.22%
71300	Career and Technical Education	(1,906,260.19)	180,606.06	9.47%	(158,855.02)	79,645.24	50.14%
72110	Attendance	(225,221.00)	28,463.94	12.64%	(18,768.42)	11,155.16	59.44%

Hickman County Finance
 Summary Financial Statement
 September 2025

141 General Purpose School		Year-To-Date			Month-To-Date		
Account	Description	Budget Estimate	Actual	% of Budget	Estimate Avg/Mth	Actual	% of Avg
72120	Health Services	(984,512.79)	145,845.49	14.81%	(82,042.73)	64,240.80	78.30%
72130	Other Student Support	(1,249,822.00)	214,868.30	17.19%	(104,151.83)	87,546.46	84.06%
72210	Regular Instruction Program	(1,709,956.00)	266,265.09	15.57%	(142,496.33)	125,168.63	87.84%
72220	Special Education Program	(480,504.00)	72,438.43	15.08%	(40,042.00)	35,850.91	89.53%
72230	Career and Technical Education	(237,028.27)	40,033.31	16.89%	(19,752.36)	14,842.79	75.14%
72250	Technology	(559,224.00)	261,357.45	46.74%	(46,602.00)	22,048.75	47.31%
72290	Other Programs	(35,000.00)	0.00	0.00%	(2,916.67)	0.00	0.00%
72310	Board Of Education	(697,742.00)	385,891.27	55.31%	(58,145.17)	13,115.67	22.56%
72320	Director Of Schools	(338,617.00)	71,160.29	21.01%	(28,218.08)	23,339.82	82.71%
72410	Office Of The Principal	(2,116,218.00)	375,463.10	17.74%	(176,351.50)	142,280.21	80.68%
72510	Fiscal Services	(50,000.00)	0.00	0.00%	(4,166.67)	0.00	0.00%
72610	Operation Of Plant	(2,704,798.00)	905,266.64	33.47%	(225,399.83)	148,216.92	65.76%
72620	Maintenance Of Plant	(1,381,503.00)	517,970.44	37.49%	(115,125.25)	91,838.71	79.77%
72710	Transportation	(2,006,898.00)	431,228.60	21.49%	(167,241.50)	148,047.44	88.52%
72810	Central And Other	(314,544.00)	39,159.82	12.45%	(26,212.00)	14,323.58	54.65%
73100	Food Service	(46,696.00)	0.00	0.00%	(3,891.33)	0.00	0.00%
73300	Community Services	(114,189.00)	13,953.24	12.22%	(9,515.75)	7,236.19	76.04%
73400	Early Childhood Education	(535,338.00)	86,357.73	16.13%	(44,611.50)	39,218.75	87.91%
76100	Regular Capital Outlay	(1,619,184.21)	198,985.55	12.29%	(134,932.02)	98,210.45	72.79%
	Total Expenditures	(40,757,473.06)	8,090,260.54	19.85%	(3,396,456.09)	3,389,475.76	99.79%
Total	141 General Purpose School	(6,293,767.79)	1,627,779.15	25.86%	(524,480.65)	510,825.72	97.40%

142 School Federal Projects		Year-To-Date			Month-To-Date		
Account	Description	Budget Estimate	Actual	% of Budget	Estimate Avg/Mth	Actual	% of Avg
Revenues							
44170	Miscellaneous Refunds	0.00	0.00	0.00%	0.00	0.00	0.00%
47131	Vocational Educ - Basic Grants To	122,275.00	0.00	0.00%	10,189.58	0.00	0.00%
47141	Title 1 Grants To Local Educ Agencies	1,295,823.18	0.00	0.00%	107,985.27	0.00	0.00%
47143	Special Education - Grants To States	1,085,813.68	0.00	0.00%	90,484.47	0.00	0.00%
47145	Special Education Preschool Grants	53,018.44	0.00	0.00%	4,418.20	0.00	0.00%
47146	English Language Acquisition Grants	0.00	0.00	0.00%	0.00	0.00	0.00%
47148	Rural Education	83,010.08	0.00	0.00%	6,917.51	0.00	0.00%
47189	Eisenhower Prof Development State	239,626.68	0.00	0.00%	19,968.89	0.00	0.00%
47309	COVID-19 Grant D	0.00	0.00	0.00%	0.00	0.00	0.00%
47401	American Rescue Plan Act Grant #1	0.00	0.00	0.00%	0.00	0.00	0.00%
47590	Other Federal Through State	145,750.53	0.00	0.00%	12,145.88	0.00	0.00%
Total Revenues		3,025,317.59	0.00	0.00%	252,109.80	0.00	0.00%
Expenditures							
71100	Regular Instruction Program	(866,577.32)	123,668.66	14.27%	(72,214.78)	71,177.82	98.56%
71200	Special Education Program	(814,441.23)	94,427.37	11.59%	(67,870.10)	42,358.40	62.41%
71300	Career and Technical Education	(100,322.25)	16,255.72	16.20%	(8,360.19)	5,130.44	61.37%
72130	Other Student Support	(33,212.79)	9,066.42	27.30%	(2,767.73)	7,823.22	282.66%
72210	Regular Instruction Program	(870,081.01)	96,613.68	11.10%	(72,506.75)	41,428.19	57.14%
72220	Special Education Program	(306,890.89)	58,522.70	19.07%	(25,574.24)	27,407.58	107.17%
72230	Career and Technical Education	(7,292.10)	177.60	2.44%	(607.68)	0.00	0.00%
72710	Transportation	(26,500.00)	1,050.00	3.96%	(2,208.33)	840.00	38.04%
Total Expenditures		(3,025,317.59)	399,782.15	13.21%	(252,109.80)	196,165.65	77.81%
Total	142 School Federal Projects	0.00	399,782.15	100.00%	0.00	196,165.65	0.00%

Template Name: LGC Summary
 Created by: LGC

Hickman County Finance
 Summary Financial Statement
 September 2025

User:
 Date/Time:

Michael Elkins
 10/15/2025 11:12 AM
 Page 4 of 4

143 Central Cafeteria		Year-To-Date			Month-To-Date		
Account	Description	Budget Estimate	Actual	% of Budget	Estimate Avg/Mth	Actual	% of Avg
Revenues							
43521	Lunch Payments - Children	0.00	(108.50)	0.00%	0.00	(87.25)	0.00%
43522	Lunch Payments - Adults	22,000.00	(5,180.67)	23.55%	1,833.33	(3,026.86)	165.10%
43523	Income From Breakfast	2,500.00	(1,885.38)	75.42%	208.33	(1,091.16)	523.76%
43525	A La Carte Sales	265,000.00	(47,894.06)	18.07%	22,083.33	(23,187.24)	105.00%
43570	Receipts From Individual Schools	0.00	0.00	0.00%	0.00	0.00	0.00%
44110	Investment Income	1,000.00	(46.72)	4.67%	83.33	(16.14)	19.37%
44170	Miscellaneous Refunds	0.00	0.00	0.00%	0.00	0.00	0.00%
47111	USDA School Lunch Program	1,800,000.00	(366,959.50)	20.39%	150,000.00	(192,904.34)	128.60%
47113	Breakfast	750,000.00	(137,346.16)	18.31%	62,500.00	(74,760.20)	119.62%
47114	USDA - Other	0.00	(1,837.08)	0.00%	0.00	(1,328.04)	0.00%
	Total Revenues	2,840,500.00	(561,258.07)	19.76%	236,708.33	(296,401.23)	125.22%
Expenditures							
73100	Food Service	(2,957,934.00)	1,201,633.31	40.62%	(246,494.50)	446,789.76	181.26%
	Total Expenditures	(2,957,934.00)	1,201,633.31	40.62%	(246,494.50)	446,789.76	181.26%
Total	143 Central Cafeteria	(117,434.00)	640,375.24	545.31%	(9,786.17)	150,388.53	1,536.

School District: Hickman County District No. 410 Date 10/13/25 Month of School _____
 School Name: Centerville Elementary School School No. 005 No. of Days In Session: 20
 Prepared By: _____ Phone: _____ Begin Date: 09/03/25 End Date: 09/30/25

Grade	Net Enrollment to Date			End of Month Membership	Average Daily Attendance	Average Daily Membership
	Male	Female	Total			
K	45	45	90	92	81.9000	91.2500
01	70	52	122	130	117.8500	129.9500
02	51	46	97	104	94.4500	103.5500
03					.0000	.0000
04					.0000	.0000
05					.0000	.0000
06					.0000	.0000
07					.0000	.0000
08					.0000	.0000
09					.0000	.0000
10					.0000	.0000
11					.0000	.0000
12					.0000	.0000
K-12	166	143	309	326	294.2000	324.7500
GRAND TOTAL	166	143	309	326	294.2000	324.7500

School District: Hickman County District No. 410 Date 10/13/25 Month of School _____
 School Name: Hickman County Middle School School No. 020 No. of Days In Session: 20
 Prepared By: _____ Phone: _____ Begin Date: 09/03/25 End Date: 09/30/25

Grade	Net Enrollment to Date			End of Month Membership	Average Daily Attendance	Average Daily Membership
	Male	Female	Total			
K					.0000	.0000
01					.0000	.0000
02					.0000	.0000
03					.0000	.0000
04					.0000	.0000
05					.0000	.0000
06	57	46	103	113	108.4000	112.6000
07	60	51	111	115	108.7500	114.0000
08	57	58	115	125	120.1000	125.6500
09					.0000	.0000
10					.0000	.0000
11					.0000	.0000
12					.0000	.0000
K-12	174	155	329	353	337.2500	352.2500
GRAND TOTAL	174	155	329	353	337.2500	352.2500

Hickman County Board of Education
Budget Amendment No. 14
General Purpose (Fund 141)
September 8, 2025

76100 - 790 -	Other Equipment	\$ 60,000.00		To move capital funds for projects that were paid out of 2025 funds to cover Mold Abatement at HCHS
76100 - 799 -	Other Capital Outlay	30,000.00		
72620 - 335 -	Maintenance - Bldg		\$ 90,000.00	
		\$ 90,000.00	\$ 90,000.00	

Approved:

Attest:

Board Chair

John Mullins

Hickman County Board of Education			
	Descriptor Term: Textbooks	Descriptor Code: 4.401	Issued Date: 08/05/24
		Rescinds: 4.401	Issued: 12/04/23

1 **SELECTION^{1,2}**

2 The selection of textbooks shall be completed according to the laws and policies required by the State
3 of Tennessee and the State Textbook Commission. The responsibility for textbook selection rests with
4 the local textbook selection committees subject to approval by the Board. Use of textbooks and
5 instructional materials not on the list approved by the State Textbook Commission is permissible if the
6 Board submits a waiver to the State Board of Education and such waiver is approved. The director of
7 schools shall establish a procedure for providing citizens of the community with an opportunity to
8 examine proposed textbooks prior to their final adoption,³ including public notice of time and location
9 at which textbooks may be examined. Once the proposed textbooks have been approved by the Board,
10 the director of schools shall post the list of all approved textbooks and instructional materials adopted
11 for use across the school system on the school system’s website and send a copy of the list to the
12 commissioner of education.²

13 When proposing procurement of new textbooks, the director of schools shall provide the Board with a
14 signed document from the textbook publisher(s) stating they have confirmed the subject textbook(s)
15 comply with TCA 49-6-1019 (also known as “Prohibited Concepts in Instruction”). If a signed
16 statement from the publisher is unavailable, a thorough review of the textbook(s) shall be performed by
17 a qualified person familiar with the subject law and provide a signed statement.

18 **COMPLAINTS & RECONSIDERATION**

19 The director of schools shall develop forms and procedures to enable citizens to file complaints
20 regarding the selection or content of approved textbooks. Following the conclusion of this
21 administrative process, a complainant may appeal an outcome to the Board.

22 **DISTRIBUTION**

23 The director of schools shall designate an employee to be responsible for the purchase and distribution
24 of textbooks in each school. The principal shall be responsible for seeing that each student receives the
25 required textbooks at no cost to the student.

26 **CERTIFICATION**

27 Annually, before the director of schools and the chair of the Board certifies compliance of textbooks to
28 the commissioner (due by October 15 of each year), each principal shall provide a signed document
29 stating they have confirmed each student in their school has the correct textbook for each class and that
30 teachers are utilizing the textbook as part of their teaching process.

1 **CARE OF TEXTBOOKS⁴**

2 Textbooks are property of the Board and shall be returned at the end of the school year, upon
3 completion of the course or upon withdrawal from a course or school. Parents are to sign an agreement
4 stating they shall be responsible for the textbooks received and used by their children.

5 The following reimbursement schedule shall be used as a guide for collecting fines for lost or
6 destroyed books:

7	Age of Book	Amount Collected
8	1 - 2 years	100% of replacement cost
9	3 - 4 years	75% of replacement cost
10	5 or more years	50% of replacement cost

11 **CARE OF DEVICES**

12 Electronic devices used for instruction are property of the Board and shall be returned at the end of the
13 year, upon completion of the course, or upon withdrawal from a school. Parents are to sign an
14 agreement stating they will be responsible for the electronic devices received and used by their
15 students. The signed agreement will include a reimbursement schedule for damages to electronic
16 devices up to 100% replacement cost.

17 The Board shall approve and periodically review a schedule of fines for damaged books. In cases
18 where the book is damaged to the extent it is no longer useable, the amount collected shall conform to
19 the reimbursement schedule for lost books. A fine may only be assessed in cases where the pupil or
20 parent damages, loses or defaces the textbook either through willful intent or neglect.

21 Following an interview with parties and an investigation, if needed, the principal may assess the
22 appropriate fine and notify the parents in writing.

23 The principal may include with the notice a provision stating that failure to pay the fine imposed
24 within a reasonable time may result in the imposition of one of the following sanctions:

- 25 1. Refusal to issue any additional textbooks until restitution is made;
- 26 2. Withholding of all grade cards, diplomas, certificates of progress, or transcripts until restitution
27 is made;
- 28 3. Not allowing the pupil to take interim or final examinations or to earn course credit in the
29 course for which the textbook is prescribed until restitution is made; or
- 30 4. Reducing the pupil's grade in the course for which the textbook is prescribed by one (1) letter
31 grade or ten (10) percentage points until restitution is made.

32 The principal may waive the assessment of fines when in his/her judgment the student is the victim of
33 uncontrollable circumstances and not responsible for the damages.

1 INSPECTION

- 2 A list of textbooks used by the schools shall be revised annually by building administrators under the
3 direction of the director of schools. Textbooks shall be available for inspection by parents/guardians
4 upon request, and the director of schools shall develop procedures for the inspection of materials and
5 distribute these procedures to each principal.

Legal References

1. [TCA 49-6-2207](#)
2. [TCA 49-6-2207\(c\), \(e\), \(f\); TCA 49-6-2202; TRR/MS 0520-01-18-.02](#)
3. [20 USCA § 1232h\(a\); TCA 49-6-7003](#)
4. [TCA 49-3-310\(1\)\(B\); TRR/MS 0520-01-02-.16\(2\)](#)

Cross Reference

Revenues 2.400
Surplus Property Sales 2.403
Library Materials 4.403
Controversial Materials 4.801
Student Fees and Fines 6.709



To Whom It May Concern:

This document serves as confirmation that all students at East Hickman Elementary School have received all necessary textbooks and workbook materials needed for the 2025-2026 school year. There has been a thorough review to ensure that every student and teacher have all textbooks and materials needed.

Principal Name: Leigha Coble

Principal Signature: Leigha Coble

Date: 9/26/25

East Hickman Intermediate School has all curriculum and resources for the 2025-26 school year.

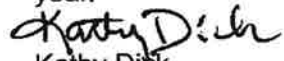
A handwritten signature in black ink that reads "Kathy Disk". The signature is written in a cursive style with a large, prominent "K" and "D".

Kathy Disk

Principal

Jana Willis
Principal

Kristin Dunn
Assistant Principal



EAST HICKMAN MIDDLE SCHOOL
9414 EAST EAGLE DRIVE
LYLES TN 37098
931-670-4237

All teachers at EHMS are equipped with the curriculum and resources necessary to effectively teach their classes.

Jana Willis
9-25-25



East Hickman High School

7700 Hwy 7
Lyles, TN 37098
Phone (931) 670-1366

Ms. Cayla Moulton
Principal

Ms. Megan Moore
Assistant Principal

This letter serves to confirm that all teachers and staff have received the necessary textbooks and instructional materials required for their individual classes for the 2025–2026 school year. Furthermore, these resources are being actively utilized in classroom instruction to support student learning and ensure alignment with district and state standards.

Thank you,

A handwritten signature in cursive script that reads "Cayla Moulton".



CENTERVILLE ELEMENTARY SCHOOL

Amy McAbee, Principal
(931) 729-2212

104 Mary Field Ave.
Centerville, TN 37033

October 13, 2025,

To Whom it May Concern:

This letter is to verify that a thorough check has been conducted and it has been verified that all students at CES have the correct textbooks for their classes. Additionally, teachers are using the appropriate high quality textbooks for instruction.

Thank you,

A handwritten signature in black ink that reads 'Amy McAbee'. The signature is written in a cursive style.

Amy McAbee



Centerville Intermediate School

110 Mary Field Avenue

Centerville, TN 37033

Phone 931-729-2748

Fax 931-729-5497

Principal, Rose Korte Stites

Assistant Principal, Tarrah Lawson



October 1, 2025,

Mr. Mullins,

All teachers at CIS have given consent that they have the textbooks they need for their students and classroom instruction.

A handwritten signature in black ink that reads "Rose K" with a stylized flourish at the end.

Rose Korte Stites

Hickman County Middle School

Principal
Tina S. Thigpen
Assistant Principal
Zach Bentley
Athletic Director
Tony Roder



1639 Bulldog Boulevard
Centerville, TN 37033

Phone: 931-729-4234
Fax: 931-701-2221

Dear Mrs. Manor and Members of the Hickman County School Board,

In alignment with Board Policy 4.401, I am confirming that all teachers and students at Hickman County Middle School are utilizing the district-adopted instructional materials. Students and teachers have the adopted textbooks and consumables needed, and these resources are being implemented in our instruction. Our faculty is committed to ensuring that the adopted materials remain the foundation of teaching and learning, providing both consistency and quality in educational practice.

Respectfully,

A handwritten signature in blue ink that reads "Tina S. Thigpen". The signature is written in a cursive style.

Tina S. Thigpen

10/02/2025

Dear Board of Education,

This document serves as confirmation that all students at HCHS have been issued the correct textbook for each of their assigned classes. A thorough review has been conducted to ensure that every student has access to the appropriate instructional materials required for their coursework. Additionally, all teachers are actively incorporating these textbooks into classroom instruction to support student learning.

This process is in full compliance with Hickman County School Board Policy 4.401, ensuring that instructional materials are properly distributed and effectively utilized to enhance the educational experience of all students.

Respectfully submitted,

Robyn Emerson
Proud Principal of Hickman County High School



Hickman County Schools Board Agenda Item Request

Date: 4/10 - Board Mtg Oct 20th
Name of School: HCHS
Item Request: Beta Club Convention

Explanation:

Beta Club would like to
go to the State Convention
ON Nov 21st-22nd.

They will spend the night at
Oakland Hotel

Kitty Bates, Kathy Qualls, + Kelly Blakes
will present to the board.

Attachments (if necessary and appropriate):

Signature of Person requesting to be placed on the agenda:

K. Carter (K. Carter)

Signature of Building Principal:

Kathy Emerson

1. Jay Massie
2. Logan French
3. Kincaid Green
4. Jackson Mayberry
5. Kitty Bates
6. Keely Blocker
7. Tiffany Vaillancourt
8. Cooper Tidwell
9. Dane Gilbert
10. Brittany Gilbert
11. Rachel Puckett
12. Jordan Hudgins
13. Trace Warren
14. Judd Rochelle
15. Kathryn Qualls
16. Kylan Seale
17. Jagger Lawson
18. Addison Cathey
19. Jack Floyd
20. Amaya Setzer
21. Clara Cochran
22. Audrey Davidson
23. Jaycee Blackwell
24. Ava Floyd
25. Mary Mitra



Hickman County Schools Board Agenda Item Request

Date: 9-16-25

Name of School: HCMS

Item Request: Overnight Trip Request

Explanation:

The Beta Club will ask the board
for permission to attend the state
convention in November.

Attachments (if necessary and appropriate):

Signature of Person requesting to be placed on the agenda:

Kuni Tally

Signature of Building Principal:

Uma S. Thigpen



Hickman County Schools Board Agenda Item Request

Date: 9/29/2025

Name of School: HCHS

Item Request: Raider Competition 1 NOV 2025

Explanation:
Request to compete in a Raider
Competition in Mayfield KY. Test our
Teamwork, Leadership, and

Attachments (if necessary and appropriate):

Signature of Person requesting to be placed on the agenda:
Seneca Moore

Signature of Building Principal:
Robyn Emerson

John Mullins
Pending BOE APPROVAL
10-1-25

Overview

Hickman County (410) Public District - FY 2026 - TISA Accountability Report - Rev 0

Overview

The Tennessee Investment in Student Achievement (TISA) public school funding formula marks a significant change in how Tennessee invests in public education. The TISA funding formula updates the way Tennessee funds public education for the first time in over 30 years to empower each student to read proficiently by third grade, prepare each high school graduate for postsecondary success, and provide resources needed for all students to ensure they succeed.

As part of TISA, T.C.A. § 49-3-112 requires each school district, starting in the 2023-24 school year, to submit an annual accountability report to the Tennessee Department of Education (department). This report must include:

- **Goals for student achievement:** One of the goals must include the district's plan to pursue the goal of seventy percent (70%) or more of the district's third grade students to score "met expectations" or "exceeded expectations" on the English Language Arts (ELA) portion of the TCAP tests. This goal must also detail the district's goal to increase 3rd grade ELA proficiency rates by 15% of the gap over the next three years (starting with the 2022-23 TCAP results) to achieve the district's stated goal of at least 70% of 3rd grade students proficient in ELA.
- Explanation of how the district's stated goals can be met within the district's budget.
- For reports submitted **starting in the 2024-25** school year, a description of how the district's budget and expenditures from the prior school year enabled the district to make progress toward the stated student achievement goals

Each district's TISA accountability report is required to be presented to the public for review and comment before the report is submitted to the department. Additionally, the TISA Accountability must be presented for local school board approval. The report must be submitted annually to the department by November 1st.

Furthermore, each district's TISA accountability report is required to be reviewed annually by the TISA Progress Review Board pursuant to T.C.A. § 49-3-114 to determine whether the school district is taking the proper steps to achieve their stated goal.

For questions, please review the TISA Accountability Report Guidance document or contact tnedu.funding@tn.gov.

Completed reports should be submitted in ePlan by **November 1, 2025**.

Resources

[Click here to open the guide.](#)

Cover Page

Hickman County (410) Public District - FY 2026 - TISA Accountability Report - Rev 0

Cover Page

* District Name

Hickman County

* Director of Schools Name

John Mullins

* District Point of Contact for TISA Accountability Report Name

Belinda Anderson

* District Point of Contact for TISA Accountability Report Phone Number

931-729-3391

District Point of Contact for TISA Accountability Report Email Address

belinda.anderson@hickmank12.org

33.3 % of 3rd grade students who scored proficient ("met expectations" or "exceeded expectations") on the English Language Arts (ELA) portion of the most recent spring TCAP

Documents

Type

Document Template

Document/Link

(TISA) Previous Year Report

N/A

 [\(TISA\) Previous Year Report](#)

Resources

[Click here to open the guide.](#)

District Goal Statements

Hickman County (410) Public District - FY 2026 - TISA Accountability Report - Rev 0

Goal Statement 1: - 3rd Grade ELA Proficiency

	70 %	of students will score proficient on the 3rd grade ELA TCAP by	Year 2030
--	------	--	--------------

District Goal Statements

Goal Number	GOAL STATEMENT(S)
Goal 2	Hickman County will show improvement in the ELA Success Rate: from 2023-24 to 2027-28 3-5 ELA 34.40% to 45.95%. 6-8 ELA 23.70% to 41.06%. 9-12 ELA 30.70% to 46.47%. as measured on the State achievement assessment and/or EOCs.
Goal 3	Hickman County will show improvement in the Math Success Rate: from 2023-24 to 27-28 3-5 Math 43.10% to 56.05%. 6-8 Math 24.50% to 41.68%. 9-12 Math 15.10% to 34.42%. as measured on the State achievement assessment and/or EOCs.
Goal 4	
Goal 5	
Goal 6	

Note: This is a required goal pursuant to T.C.A. § 49-3-112 and must include 70% or more of 3rd grade students proficient on the ELA TCAP. If your district already has 70% or more of 3rd grade students proficient in ELA, please state a goal that either maintains or increases that proficiency rate.

Goal #1

Hickman County (410) Public District - FY 2026 - TISA Accountability Report - Rev 0

Goal Statement 1: 3rd Grade ELA Proficiency

<input type="text" value="70"/> %	of students will score proficient on the 3rd grade ELA TCAP by	Year <input type="text" value="2030"/>
-----------------------------------	--	---

District Goal 1

Year	Annual Outcome Target(s)	Associated Metrics/Data
Year 1: 2023-2024 school year (Previous outcome)	33%	2024 TCAP and EOC success rate all students as well as the gap formula for TISA
Year 2: 2024-2025 school year (Use actual outcome)	33.3%	2025 TCAP and EOC success rate all students as well as the gap formula for TISA
Year 3: 2025-2026 school year	48%	2026 TCAP and EOC success rate all students as well as the gap formula for TISA
Year 4: 2026-2027 school year	55.7%	2027 TCAP and EOC success rate all students as well as the gap formula for TISA
Year 5: 2027-2028 school year	63.5%	2028 TCAP and EOC success rate all students as well as the gap formula for TISA

* Check the response that best describes the progress made on the 2024-25 target toward Goal 1.

- Exceeded target
- Met target
- Increased but did not meet target
- Did not make progress toward target
- End of year outcome data for 2024-25 is unavailable at the time of this report

Reflection: Based on progress toward the goal, how will this impact your action plan for the coming years?

Progress toward the 2030 goal of 70% proficiency in 3rd grade ELA has remained flat, with 33.3% in 2024-25 compared to 33% in 2023-24. This indicates that current strategies have not yet produced measurable gains. Moving forward, the action plan will need to focus on stronger alignment to standards, targeted early literacy interventions, and consistent progress monitoring. Greater emphasis will be placed on instructional coaching, foundational skills in K-2, and differentiated supports to accelerate growth and ensure year-over-year improvement toward the long-term goal. We are continuing to work toward closing the gap from a baseline of 33% to 70%. Our goal for this year is to reach 39% to stay on track toward full gap closure.

Goal 1 Prior Year Report: 2-3 Prior year, major TISA investments made toward this goal

Major TISA Investment	Expended Amount (Rough Estimate)	Reflection of whether the investment contributed to progressing toward the goal or not, and how so.
<p>In the previous year, investments were directed toward testing software such as Mastery Connect, teacher planning tools like Planbook, and professional development focused on data analysis and standards-based instruction. These initiatives, along with ongoing efforts to strengthen instruction-through learning walks, development of instructional materials, and improved communication with educators-represented the primary investments aligned with this goal.</p>	<p>\$ 250,000.00</p>	<p>While data is not showing improvement as originally forecasted, the investment will continue into the tools and professional development previously described. We will look at additional professional development and other software and strategies that can enhance the growth of staff and students.</p>

Action Plan: List detailed strategies for the 2025-2026 school year that will be implemented to meet your annual target.

Action Plan: 2025-2026: To meet our annual target and move toward 70% proficiency in 3rd grade ELA by 2030, the following strategies will be implemented:

1. K-2 Foundational Skills Focus - Partner with NIET to strengthen instruction and intervention in phonological awareness, phonics, fluency, and vocabulary through targeted walkthroughs, coaching, and feedback cycles.
2. Standards Annotations - Ensure that Tennessee ELA Standards remain the central focus by using standards annotation to drive instructional planning and walkthrough look-fors.
3. HQIM Rigor Checks - Compare the rigor of high-quality instructional materials (HQIM) to Tennessee ELA Standards, ensuring lessons consistently meet or exceed grade-level expectations.
4. PLC Standards Deconstruction - Use ELA Standards Guides in PLCs to deconstruct standards, identify instructional priorities, and align lesson planning to targeted student outcomes.
5. Progress Monitoring & Data Talks - Establish monthly data talks focused on early literacy progress, using multiple data points (universal screeners, running records, formative assessments) to guide tiered interventions and instructional adjustments.

Budget Narrative: Describe how your district intends to use their budget to execute the strategies and meet the stated goal.

The investment into defined strategies above will continue as we also look at additional professional development and other software and strategies that will complement the classroom instruction.

Goal #2

Hickman County (410) Public District - FY 2026 - TISA Accountability Report - Rev 0

Goal Statement 2:

Hickman County will show improvement in the ELA Success Rate:
from 2023-24 to 2027-28
3-5 ELA 34.40% to 45.95%.
6-8 ELA 23.70% to 41.06%.
9-12 ELA 30.70% to 46.47%.
as measured on the State achievement assessment and/or EOCs.

District Goal 2

Year	Annual Outcome Target(s)	Associated Metrics/Data
Year 1: 2023-2024 school year (Previous outcome)	34.40% 23.70% 30.70%	2024 TCAP and EOC success rate all students as well as AMO's for the following years
Year 2: 2024-2025 school year (Use actual outcome)	35.80% 24.10% 32.80%	2025 TCAP and EOC success rate all students as well as AMO's for the following years
Year 3: 2025-2026 school year	42.34% 32.94% 39.09%	2026 TCAP and EOC success rate all students as well as AMO's for the following years
Year 4: 2026-2027 school year	45.95% 37.13% 42.90%	2027 TCAP and EOC success rate all students as well as AMO's for the following years
Year 5: 2027-2028 school year	49.33% 41.06% 46.47%	2028 TCAP and EOC success rate all students as well as AMO's for the following years

* Check the response that best describes the progress made on the 2024-25 target toward Goal 2.

- Exceeded target
- Met target
- Increased but did not meet target
- Did not make progress toward goal
- End of year outcome data for the 2024-25SY is unavailable at the time of this report

Reflection: Based on progress toward the goal, how will this impact your action plan for the coming years?

ELA Success Rates in grades 3-12 increased in 2024-25, demonstrating positive momentum but not yet meeting the overall target. This progress reinforces the importance of continuing to strengthen early literacy (K-2 foundational skills) while deepening alignment to Tennessee ELA standards across all grade bands. Moving forward, the action plan will emphasize rigorous use of HQIM, standards-focused PLCs, and ongoing walkthrough feedback to accelerate growth and close remaining gaps.

Goal 2 Prior Year Report: 2-3 Prior year, major TISA investments made toward this goal

Major TISA Investment	Expended Amount (Rough Estimate)	Reflection of whether the investment contributed to progressing toward the goal or not, and how so.
<p>Hickman County made two significant initial TISA investments to advance its ELA goals. First, funding supported initiatives such as learning walks, the development of instructional materials, and enhanced communication with educators. Second, the district allocated resources to improve student attendance and hire a district-level coach. This coach played a vital role in implementing a county-wide writing process and supporting the development of PLC structures throughout the district. These investments continued in the 2025 school year along with professional development and other training relating to early literacy foundational skills.</p>	<p>\$ 130,000.00</p>	<p>Hickman County's initial TISA investments supported positive progress toward ELA goals. Increases in grades 3-12 ELA success rates during 2024-25 reflect the impact of initiatives like learning walks, instructional support, and the addition of a district coach. While the overall target was not yet met, the momentum reinforces the need to continue strengthening early literacy and aligning instruction to Tennessee ELA standards. Ongoing focus on HQIM, PLCs, and walkthrough feedback will be key to accelerating growth and closing remaining gaps.</p>

Action Plan: List detailed strategies for the 2025-2026 school year that will be implemented to meet your annual target.

- Action Plan: 2025-2026
1. Early Literacy Emphasis - Strengthen K-2 instruction by embedding NIET coaching cycles and walkthrough feedback that focus on building strong foundational skills in phonics, fluency, and vocabulary.
 2. Standards-Driven Planning - Ensure Tennessee ELA Standards guide instructional decisions by using standards annotation and prioritizing alignment during lesson planning and PLC discussions.
 3. Curriculum & Rigor Checks - Regularly review HQIM lessons against state standards to confirm that the level of rigor meets or exceeds grade-level expectations, making adjustments where gaps are found.
 4. PLC Focus on Student Evidence - Use PLC time to examine student work samples and assessments, identifying trends and refining instruction to better support mastery of grade-level standards.
 5. Ongoing Data Conversations - Hold consistent school-level data talks to monitor progress, celebrate growth, and quickly respond with interventions when students are not meeting benchmarks.

Budget Narrative: Describe how your district intends to use their budget to execute the strategies and meet the stated goal.

The investment into defined strategies above will continue as we also look at additional professional development and other software and strategies that will complement the classroom instruction.

Goal #3

Hickman County (410) Public District - FY 2026 - TISA Accountability Report - Rev 0

This goal not established.

Goal Statement 3:

Hickman County will show improvement in the Math Success Rate:
 from 2023-24 to 27-28
 3-5 Math 43.10% to 56.05%.
 6-8 Math 24.50% to 41.68%.
 9-12 Math 15.10% to 34.42%.
 as measured on the State achievement assessment and/or EOCs.

District Goal 3

Year	Annual Outcome Target(s)	Associated Metrics/Data
Year 1: 2023-2024 school year (Previous outcome)	43.10% 24.50% 15.10%	2024 TCAP and EOC success rate all students as well as AMO's for the following years
Year 2: 2024-2025 school year (Use actual outcome)	42.80% 32.70% 19.20%	2025 TCAP and EOC success rate all students as well as AMO's for the following years
Year 3: 2025-2026 school year	49.99% 33.64% 25.38%	2026 TCAP and EOC success rate all students as well as AMO's for the following years
Year 4: 2026-2027 school year	53.12% 37.79% 30.04%	2027 TCAP and EOC success rate all students as well as AMO's for the following years
Year 5: 2027-2028 school year	56.05% 41.68% 34.42%	2028 TCAP and EOC success rate all students as well as AMO's for the following years

* Check the response that best describes the progress made on the 2024-25 target toward Goal 3.

- Exceeded target
- Met target
- Increased but did not meet target
- Did not make progress toward goal
- End of year outcome data for the 2024-25SY is unavailable at the time of this report

Reflection: Based on progress toward the goal, how will this impact your action plan for the coming years?

Math outcomes for 2024-25 showed mixed results across grade bands. Grades 6-8 exceeded the target, while grades 9-12 increased but did not meet the target, and grades 3-5 declined slightly from the previous year. This uneven progress indicates that while some strategies are producing results, others need strengthening. Moving forward, the action plan will emphasize consistency in standards-based instruction, targeted support in elementary math, and deeper alignment between curriculum, assessments, and state expectations. Continued progress monitoring and PLC collaboration around student work will be critical to ensuring steady growth across all grade levels.

Goal 3 Prior Year Report: 2-3 Prior year, major TISA investments made toward this goal

Major TISA Investment	Expended Amount (Rough Estimate)	Reflection of whether the investment contributed to progressing toward the goal or not, and how so.
<p>For the 2024-2025 school year, Hickman County implemented three key strategies to strengthen numeracy instruction: structured lesson planning, classroom walkthroughs, and targeted professional learning. Lesson Plans: Teachers used structured plans to organize math instruction, ensuring clarity on what to teach and when, while allowing for differentiation based on student needs and progress monitoring. Classroom Walkthroughs: Frequent classroom observations provided actionable feedback to help teachers enhance their instructional practices and better support student learning. Professional Development (PD) and Professional Learning Communities (PLCs): Ongoing training and collaborative PLC sessions helped create opportunities for teachers to share effective strategies and continuously improve instruction. In addition, the district's coaching team met biweekly to refine coaching practices and analyze Mastery Connect benchmark data alongside TCAP results. This analysis was shared during monthly assistant principal and principal meetings, equipping school leaders to guide PLCs and support data-driven decision-making aligned with the district's Annual Measurable Objectives (AMOs).</p>	<p>\$ 150,000.00</p>	<p>The TISA-funded strategies implemented in 2024-25-structured lesson planning, classroom walkthroughs, and professional learning-contributed to mixed progress in math outcomes. While grades 6-8 exceeded targets, gains in high school and declines in elementary suggest that instructional consistency and alignment remain areas for growth. The use of data through coaching meetings and PLCs supported informed decision-making, but targeted support in elementary math and continued focus on standards-based instruction will be essential to achieving consistent growth across all grade levels.</p>

Action Plan: List detailed strategies for the 2025-2026 school year that will be implemented to meet your annual target.

Action Plan: 2025-2026 - Math

1. Strengthen Conceptual Understanding - Teachers will use manipulatives, models, and multiple representations in daily lessons to help students move from concrete to abstract thinking in math.
2. Focus on Priority Standards - Grade-level PLCs will identify and emphasize the most tested and foundational Tennessee Math Standards, ensuring instruction spirals and builds across grade bands.
3. Align Tasks to Rigor - Regular reviews of classroom assignments and assessments will ensure that student tasks reflect the depth and rigor of TCAP and EOC expectations, especially at the "Level 3" benchmark.
4. Data-Driven Interventions - Schools will implement structured data talks each month to review student performance, identify those below benchmark, and provide targeted small-group or tiered support.
5. Professional Collaboration - Math coaches and teacher leaders will model lessons, co-plan, and facilitate collaborative scoring of student work so that all teachers build confidence in delivering rigorous, standards-aligned instruction.

Budget Narrative: Describe how your district intends to use their budget to execute the strategies and meet the stated goal.

The investment into defined strategies above will continue as we also look at additional professional development and other software and strategies that will complement the classroom instruction.

Hickman County Board of Education
Budget Amendment No. 15
General Purpose - Fund 141
October 20, 2025

Account	Description	Debit	Credit	Justification
72710 - 146 -	Bus Drivers	\$ 115,000.00		To Properly record SPED Transportation
72710 - 201 -	Social Security	8,797.50		
72710 - 204 -	State Retirement	13,627.50		
72710 - 146 - SE	Bus Drivers - SE		85,000.00	
72710 - 189 - SE	Other Salaries - SE		30,000.00	
72710 - 201 - SE	Social Security - SE		8,797.50	
72710 - 204 - SE	State Retirement		13,627.50	
76100 - 707 -	Building Improvements		60,000.00	
76100 - 790 -	Other Equipment	60,000.00		
72810 - 499 -	Other Supplies	7,500.00		To track expenditures related to donations
72810 - 499 - SS	Other Supplies		7,500.00	
TOTALS		\$ 204,925.00	\$ 204,925.00	

Approved:

Attest:

Board Chair

John Mullins

Hickman County Board of Education
Budget Amendment No. 16
General Purpose - Fund 141
October 20, 2025

Account	Description	Debit	Credit	Justification
46790 - - ISM	Other Vocational - ISM	\$1,518,000.00		To bring Innovative School Model (ISM) budget into agreement with ePlan
46790 - -	Other Vocational		1,518,000.00	
71300 - 429 - ISM	Instructaional Supplies	3,125.35		
71300 - 429 - ISMC	Instructional Supplies	3,011.31		
71300 - 730 - ISM	CTE Instruction Equip		16,511.28	
72230 - 189 - ISM	Other Salaries	4,472.97		
72230 - 201 - ISM	Social Security		110.72	
72230 - 204 - ISM	State Retirement	4,063.02		
72230 - 207 - ISM	Medical Ins	6,657.78		
76100 - 706 - ISM	Bldg Construction		593,708.43	
76100 - 707 - ISM	Bldg Improvements		170,000.00	
76100 - 706 -	Bldg Construction	759,000.00		
TOTALS		\$2,298,330.43	\$2,298,330.43	

Approved:

Attest:

Board Chair

John Mullins

Hickman County Board of Education
Budget Amendment No. 17
General Purpose - Fund 141
October 20, 2025

Account	Description	Debit	Credit	Justification	
39000 - -	Fund Balance		\$ 13,643.80		
72120 - 189 - OFG	Other Salaries	\$ 50,000.00		To properly record Opioid Grant Carryover in requested Cost Centers	
72120 - 201 - OFG	Social Security	3,825.00			
72120 - 204 - OFG	State Retirement	4,500.00			
72120 - 599 - OFG	Other Charges	61,675.00			
72120 - 189 - BH	Other Salaries		50,000.00		
72120 - 201 - BH	Social Security		3,825.00		
72120 - 204 - BH	State Retirement		4,500.00		
72120 - 599 - BH	Other Charges		41,675.00		
72120 - 599 - PN	Other Charges		6,356.20		
	TOTALS	\$ 120,000.00	\$ 120,000.00		

Approved:

Attest:

Board Chair

John Mullins

Hickman County Board of Education
 Budget Amendment No. 18
 Federal Programs - Fund 142
 October 20, 2025

Account	Description	Debit	Credit	Justification
47141 - - - 101	Title I - Revenue	\$9,201.73		To bring Title I into agreement with ePlan
71100 - 429 - - 101	Instructional Supplies		9,201.73	
72210 - 524 - - 201	Inservice	\$1,000.00		To bring Title II into agreement with ePlan
47189 - - - 201	Title II - Revenue		1,000.00	
72210 - 499 - - 401	Other Supplies	9,201.73		To bring Title IV into agreement with ePlan
47590 - - - 401	Title IV - Revenue		9,201.73	
47148 - - - 601	Title V - Revenue	1,000.00		To bring Title V into agreement with ePlan
72210 - 499 - - 601	Other Supplies	3,515.87		
72210 - 790 - - 601	Other Equipment		4,515.87	
Totals		\$ 23,919.33	\$ 23,919.33	

Approved:

Attest:

Board Chair

John Mullins

**CONTRACT TO AUDIT ACCOUNTS
OF
Hickman County Schools - Internal School Funds**

FROM July 01, 2025 TO June 30, 2026

This agreement made this 30th day of September 2025, by and between Matlock Clements, PC, 270 Glenis Drive, Suite A, Murfreesboro, TN 37129, hereinafter referred to as the "auditor" and Hickman County Schools - Internal School Funds, of 115 Murphree Avenue, Centerville, TN 37033, hereinafter referred to as the "organization", as follows:

1. In accordance with the requirements of the laws and/or regulations of the State of Tennessee, the auditor shall perform a financial and compliance audit of the organization for the period beginning July 01, 2025, and ending June 30, 2026 with the exceptions listed below:
This is an audit of the Internal School Funds and the limited USDA cafeteria procedures, as outline in the Internal School Funds Manual
2. The auditor shall conduct the audit in accordance with *Government Auditing Standards* issued by the Comptroller General of the United States and requirements prescribed by the Comptroller of the Treasury, State of Tennessee, as detailed in the *Audit Manual*. Additional information and procedures necessary to comply with requirements of governments other than the State of Tennessee are permissible provided they do not conflict with or undermine the requirements previously referenced. If applicable, the audit is to be conducted in accordance with the provisions of the Single Audit Act and Title 2 U.S. Code of Federal Regulations Part 200, *Uniform Administrative Requirements, Cost Principles, and Audit Requirements for Federal Awards (Uniform Guidance)*. The audit is also to be conducted in accordance with any other applicable federal agency requirements. It is agreed that this audit will conform to standards, procedures, and reporting requirements established by the Comptroller of the Treasury. It is further agreed that any deviation from these standards and procedures will be approved in writing by the Comptroller of the Treasury prior to the execution of the contract. The interpretation of this contract shall be governed by the above-mentioned publications and the laws of the State of Tennessee.
3. The auditor shall, as part of the written audit report, submit to the organization's management and those charged with governance:
 - a) a report containing an expression of an unmodified or modified opinion on the financial statements, as prescribed by the *Audit Manual*. This report shall state the audit was performed in accordance with *Government Auditing Standards*, except when a disclaimer of opinion is issued. If the organization is a component unit or fund of another entity, it is agreed that: (a) the financial statements may be included in the financial statements of the other entity; (b) the principal auditor for the other entity may rely upon the contracted auditor's report; and (c) any additional information required by the principal auditor of the other entity will be provided in a timely manner.
 - b) a report on the internal control and on compliance with applicable laws and regulations and other matters. This report shall be issued regardless of whether the organization received any federal funding. Audit reports of entities which are subject to the provisions of the Single Audit Act and OMB's Uniform Guidance shall include the additional reports required by that guidance. The reports will set forth findings, recommendations for improvement, concurrence or nonconcurrence of appropriate officials with the audit findings, comments on management's responses as appropriate, and comments on the disposition of prior year findings.
4. If a management letter or any other reports or correspondence relating to other matters involving internal controls or noncompliance are issued in connection with this audit, a copy shall be filed with the Comptroller of the Treasury by the auditor. Such management letters, reports, or correspondence shall be consistent with the findings published in the audit report (i.e., they shall disclose no reportable matters or significant deficiencies not also disclosed in the findings found in the published audit report). The report should also include a corrective action plan for findings developed under OMB's Uniform Guidance and for other findings in accordance with Tennessee Code Annotated § 9-3-407, and the *Audit Manual*. The corrective action plan is only applicable to findings published in the audit report.
5. The auditor shall file **one (1)** electronic copy of said report with the Comptroller of the Treasury, State of Tennessee. The auditor shall furnish **20** printed copies and/or an electronic copy of the report to the organization's management and those charged with governance. It is anticipated that the auditor's report shall be filed no later than **December 31, 2026**, or **six (6) months following the period to be audited, whichever is earlier, without explanation to the Comptroller of the Treasury, State of Tennessee, and the organization. (Audit documentation for additional procedures for centralized cafeteria systems contracted with audits of internal school funds must be completed and available for review by September 30 following the fiscal year being audited.)** Requirements for additional copies, including those to be filed with the appropriate officials of granting agencies, are listed below:
6. The auditor agrees to retain working papers for no less than five (5) years from the date the report is received by the Comptroller of the Treasury, State of Tennessee. In addition, the auditor agrees that all audit working papers shall, upon request, be made available in the manner requested by the Comptroller for review by the Comptroller of the Treasury or the Comptroller's representatives, agents, and legal counsel, while the audit is in progress and/or subsequent to the completion of the report. Furthermore, at the Comptroller's discretion, it is agreed that the working papers will be reviewed at the office of the auditor, the entity, or the Comptroller and that copies of the working papers can be made by the Comptroller's representatives or may be requested to be made by the firm and may be retained by the Comptroller's representatives.
7. Any reasonable suspicion of fraud, (regardless of materiality) or other unlawful acts including, but not limited to, theft, forgery, credit/debit card fraud, or any other act of unlawful taking, waste, or abuse of, or official misconduct, as defined in Tennessee Code Annotated § 39-16-402, involving public money, property, or services shall, upon discovery, be promptly reported in writing by the auditor to the Comptroller of the Treasury, State of Tennessee, who shall under all circumstances have the authority, at the discretion of the Comptroller, to directly investigate such matters. Notwithstanding anything herein to the contrary, the Comptroller of the Treasury, State of Tennessee, acknowledges that the auditor's responsibility hereunder is to design its audit to obtain reasonable, but not absolute, assurance of detecting fraud that would have a material effect on the financial statements, as well as other illegal acts or violations of provisions of contracts or grant agreements having a direct and material effect on financial statement amounts. If the circumstances disclosed by the audit call for a more detailed investigation by the auditor than necessary under ordinary circumstances, the auditor shall inform the

organization's management and those in charge of governance in writing of the need for such additional investigation and the additional compensation required therefor. Upon approval by the Comptroller of the Treasury, an amendment to this contract may be made by the organization's management, those charged with governance, and the auditor for such additional investigation.

8. **Group Audits.** The provisions of Section 8 relate exclusively to contracts to audit components of a group under AU-C 600, (See definitions in AU-C 600, Paragraph 11.) Section 8 is only applicable to an auditor that audits a component (e.g., a fund, component unit, or other component) of a county government that is audited by the Division of Local Government Audit (LGA). Section 8 is intended to satisfy the communication requirements for the group auditor (LGA) to the component auditor under AU-C 600.

- a) The Division of Local Government Audit (LGA) shall be considered the "group auditor" for any contract to audit a component of an applicable county government. LGA shall present the county's financial statements in compliance with U.S. Generally Accepted Accounting Principles (GAAP) as promulgated by the Governmental Accounting Standards Board (GASB). LGA shall conduct the audit in accordance with auditing standards generally accepted in the United States of America and the auditing standards applicable to financial audits contained in *Government Auditing Standards* issued by the Comptroller General of the United States.
- b) The contracting auditor shall be considered the "component auditor" for purposes of this section.
- c) The financial statements audited by the component auditor should be presented in accordance with GAAP as promulgated by GASB. If the financial reporting framework for any component does not conform to this basis, the financial reporting framework should be disclosed in Section 10 (Special Provisions). (Component financial statements that are not presented using the same financial reporting framework as the county's financial statements may cause this contract to be rejected.)
- d) The component auditor shall conduct the component audit in accordance with auditing standards generally accepted in the United States of America and the auditing standards applicable to financial audits contained in *Government Auditing Standards* issued by the Comptroller General of the United States.
- e) The component auditor shall cooperate with LGA to accomplish the group audit. It is anticipated that LGA will make reference to the component auditor's report in the group audit report. Should LGA find it necessary to assume responsibility for the component auditor's work, the terms, if any, shall be negotiated under a separate addendum to this contract.
- f) The component auditor shall follow the ethical requirements of *Government Auditing Standards* and affirms that the component auditor is independent to perform the audit and will remain independent throughout the course of the component audit engagement.
- g) The component auditor affirms that the component auditor is professionally competent to perform the audit. LGA may confirm certain aspects of the component auditor's competence through the Tennessee State Board of Accountancy.
- h) The component auditor will be contacted via email by the LGA's Audit Review Manager with the estimated date of the conclusion of LGA's audit of the county government. The component auditor agrees to update subsequent events between the date of the component auditor's report and the date of the conclusion of LGA's audit of the county government. Additional subsequent events should be communicated via email to LGA's Audit Review Manager.
- i) The component auditor shall read LGA's audited financial statements for the county government for the previous fiscal year noting in particular related parties in the notes to the financial statements, and material misstatement findings in the Findings and Questioned Costs Section. The previous year audited financial statements can be obtained from the Comptroller's website at www.comptroller.tn.gov. As required by generally accepted auditing standards, we have identified Management Override of Controls and Improper Revenue Recognition as presumptive fraud risks. The component auditor shall communicate to LGA (i.e., group management) on a timely basis related parties not previously identified by the group management in LGA's prior year audited financial statements. Related parties should be communicated via email to LGA's Audit Review Manager.
- j) The component auditor's report should not be restricted as to use in accordance with AU-C 905.
- k) Sections 1-7 and Sections 10-14 of this contract are also applicable to the component auditor during the performance of the component audit.

9. **Municipal Chart of Accounts Crosswalk.** The provisions of Section 9 relate exclusively to contracts to audit of a municipality, municipality's fund(s), and municipality's school board of education. The auditor shall convert respective municipal audited financial data into a condensed chart of accounts by use of a Microsoft Excel crosswalk tool prescribed by the Comptroller of the Treasury, State of Tennessee, or if a respective municipality, municipality's fund(s), or municipality's school board of education chooses to convert their own audited financial data by use of the crosswalk, the auditor shall verify the accuracy of their conversion. The completed condensed chart of accounts crosswalk in Microsoft Excel format shall be filed with the Comptroller of the Treasury, State of Tennessee, by the auditor when the audited financial report is submitted.

10. (Special Provisions)

11. In consideration of the satisfactory performance of the provisions of this contract, the organization shall pay to the auditor the fee(s) listed below. (Fees may be fixed amounts or estimated.)

Fixed Contract Fee:

Audit **\$35,000.00**

Municipal Chart of Accounts Crosswalk **\$0.00**

Total Fixed Contract Fee **\$35,000.00**

or

Estimated Contract Fee:

Audit

Municipal Chart of Accounts Crosswalk

Total Estimated Contract Fee

(If not a fixed amount, an estimated contract fee should be furnished to the governing unit for budgetary purposes. A schedule of fees and/or rates should be set forth below. Interim billings may be arranged with consent of both parties to this contract.) Provision for the payment of fees under this agreement has been or will be made by appropriation of management and those charged with governance.

SCHEDULE OF FEES AND/OR RATES:

12. As the authorized representative of the firm, I do hereby affirm that:
- our firm and all individuals participating in the audit are in compliance with all requirements of the Tennessee State Board of Accountancy and;
 - our firm has participated in an external quality control review at least once every three (3) years, conducted by an organization not affiliated with our firm, and that a copy of our most recent external quality control review report has been provided to the organization and the office of the Tennessee Comptroller of the Treasury approving this contract;
 - all members of the staff assigned to this audit have obtained the necessary hours of continuing professional education required by *Government Auditing Standards*;
 - all auditors participating in the engagement are independent under the requirements of the American Institute of Certified Public Accountants and *Government Auditing Standards*.

13. This writing, including any amendments or special provisions, contains all terms of this contract. There are no other agreements between the parties hereto and no other agreements relative hereto shall be enforceable, unless entered into in accordance with the procedures set out herein and approved by the Comptroller of the Treasury, State of Tennessee. In the event of a conflict or inconsistency between this contract and the special provisions contained in paragraph 10 of this contract, the special provision(s) are deemed to be void. Any changes to this contract must be agreed to in writing by the parties hereto and must be approved by the Comptroller of the Treasury, State of Tennessee. All parties agree that the digital signatures, that is, the electronic signatures applied by submitting the contract, are acceptable as provided for in the Uniform Electronic Transaction Act. Any paper documents submitted related to this contract will be converted to an electronic format and such electronic document(s) will be treated as the official document(s).

14. If any term of this contract is declared by a court having jurisdiction to be illegal or unenforceable, the validity of the remaining terms will not be affected, and, if possible, the rights and obligations of the parties are to be construed and enforced as if the contract did not contain that term.

Matlock Clements, PC

Audit firm



Andy Matlock, CPA

By _____
Signature

Title/Position: **Audit Manager**

E-mail address: **eric@matlockclements.com**

Date: **October 01, 2025**

Governmental Unit or Organization

By _____
Signature

Title/Position:

E-mail address:

Date:

Approved by the Comptroller of the Treasury, State of Tennessee

For the Comptroller:

By _____ Date: _____

Construction Bid Tabulation Sheet

East Hickman High School Ag/Voc Building

Date 10/16/2025 Opening Time: 10:00 AM
LCMA #: 1402.1

Hughes

General Contractor & Subs.	License #	Exp. Date	Addenda #1	Base Bid Price	Yes / No	Bid Form
G.C.:	#			\$680,129.00	Yes / No	Bid Form
Location:					Yes / No	5% Bid Bond/Cash. Check/Certified Check
Electrical Sub:	#				Yes / No	Conflict of Interest
Plumbing Sub:	#				Yes / No	Iran Divestment
HVAC Sub:	#				Yes / No	Non-Boycott of Israel
Roofing Sub:	#				Yes / No	Identification of SMWVO
Masonry Sub:	#				Yes / No	Attest. Illegal Immigrant 00200 Form of Proposal #8 (Not req'd with Bid)
					Yes / No	W9 Form (Not Req'd Until Contracting)

Providence

General Contractor & Subs.	License #	Exp. Date	Addenda #1	Base Bid Price	Yes / No	Bid Form
G.C.:	#			\$684,000.00	Yes / No	Bid Form
Location:					Yes / No	5% Bid Bond/Cash. Check/Certified Check
Electrical Sub:	#				Yes / No	Conflict of Interest
Plumbing Sub:	#				Yes / No	Iran Divestment
HVAC Sub:	#				Yes / No	Non-Boycott of Israel
Roofing Sub:	#				Yes / No	Identification of SMWVO
Masonry Sub:	#				Yes / No	Attest. Illegal Immigrant 00200 Form of Proposal #8 (Not req'd with Bid)
					Yes / No	W9 Form (Not Req'd Until Contracting)

Fellowship

General Contractor & Subs.	License #	Exp. Date	Addenda #1	Base Bid Price	Yes / No	Bid Form
G.C.:	#			\$580,000.00	Yes / No	Bid Form
Location:					Yes / No	5% Bid Bond/Cash. Check/Certified Check
Electrical Sub:	#				Yes / No	Conflict of Interest
Plumbing Sub:	#				Yes / No	Iran Divestment
HVAC Sub:	#				Yes / No	Non-Boycott of Israel
Roofing Sub:	#				Yes / No	Identification of SMWVO
Masonry Sub:	#				Yes / No	Attest. Illegal Immigrant 00200 Form of Proposal #8 (Not req'd with Bid)
					Yes / No	W9 Form (Not Req'd Until Contracting)

Received by: _____

Construction Bid Tabulation Sheet

East Hickman High School Ag/Voc Building

Date 10/16/2025 Opening Time: 10:00 AM
LCMA #: 1402.1

General Contractor & Subs.	License #	Exp. Date	Addenda #1	Base Bid Price	Yes / No	Bid Form
Orion				\$893,875.00		
G.C.:	#				Yes / No	Bid Form
Location:					Yes / No	5% Bid Bond/Cash. Check/Certified Check
Electrical Sub:	#				Yes / No	Conflict of Interest
Plumbing Sub:	#				Yes / No	Iran Divestment
HVAC Sub:	#				Yes / No	Non-Boycott of Israel
Roofing Sub:	#				Yes / No	Identification of SMWVO
Masonry Sub:	#				Yes / No	Attest. Illegal Immigrant
					Yes / No	00200 Form of Proposal #8 (Not req'd with Bid)
					Yes / No	W9 Form (Not Req'd Until Contracting)

General Contractor & Subs.	License #	Exp. Date	Addenda #1	Base Bid Price	Yes / No	Bid Form
MDI				\$769,261.63		
G.C.:	#				Yes / No	Bid Form
Location:					Yes / No	5% Bid Bond/Cash. Check/Certified Check
Electrical Sub:	#				Yes / No	Conflict of Interest
Plumbing Sub:	#				Yes / No	Iran Divestment
HVAC Sub:	#				Yes / No	Non-Boycott of Israel
Roofing Sub:	#				Yes / No	Identification of SMWVO
Masonry Sub:	#				Yes / No	Attest. Illegal Immigrant
					Yes / No	00200 Form of Proposal #8 (Not req'd with Bid)
					Yes / No	W9 Form (Not Req'd Until Contracting)

General Contractor & Subs.	License #	Exp. Date	Addenda #1	Base Bid Price	Yes / No	Bid Form
Romach				\$619,547.00		
G.C.:	#				Yes / No	Bid Form
Location:					Yes / No	5% Bid Bond/Cash. Check/Certified Check
Electrical Sub:	#				Yes / No	Conflict of Interest
Plumbing Sub:	#				Yes / No	Iran Divestment
HVAC Sub:	#				Yes / No	Non-Boycott of Israel
Roofing Sub:	#				Yes / No	Identification of SMWVO
Masonry Sub:	#				Yes / No	Attest. Illegal Immigrant
					Yes / No	00200 Form of Proposal #8 (Not req'd with Bid)
					Yes / No	W9 Form (Not Req'd Until Contracting)

Received by: _____

Agricultural/Vocational Building at East Hickman County High School

SECTION C-00300

STATE CONTRACTOR LICENSE INFORMATION FORM

Complete applicable portions of this form and attach to the outside of envelope containing the Bid

Bidder/Prime Contractor Name: Fellowship Construction, Inc.
Street Address: P.O. Box 310 (Mailing), 2668 Spencer Mill Rd.
City, State, Zip: Bon Aqua, TN 37025

If bid amount is \$25,000 or greater, Bidder shall complete Tennessee Contractor License Information:

License No.: 49297 Expiration Date: 09/30/2027
License Classification: BC; License Limit: Unlimited

Electrical Contractor

(should subcontract portion be \$25,000 or greater, Tennessee Contractor License Information shall also be provided)

Name: Optimal Electric Pro, LLC
License No.: 72880
License Classification: CE
License Expiration Date: 11-30-2026
License Limit: \$1,417,366

Plumbing Contractor

(should subcontract portion be \$25,000 or greater, Tennessee Contractor License Information shall also be provided)

Name: Schaffer Plumbing, Inc.
License No.: 64174
License Classification: CML-A
License Expiration Date: 11-30-2026
License Limit: \$3,000,000

Heating, Ventilation and Air Conditioning (HVAC) Contractor

(should subcontract portion be \$25,000 or greater, Tennessee Contractor License Information shall also be provided)

Name: Air Specialist of Middle TN
License No.: 43481
License Classification: CML-C
License Expiration Date: 4-30-2027
License Limit: \$1,500,000

Vertical Closed Loop Geothermal Heating and Cooling Contractor

(should subcontract portion be \$25,000 or greater, Tennessee Contractor License Information shall also be provided)

Name: N/A
License No.: N/A
License Classification: N/A
License Expiration Date: N/A
License Limit: N/A

Roofing Contractor

(should subcontract portion be \$25,000 or greater, Tennessee Contractor License Information shall also be provided)

Name: N/A < \$25,000
License No.: [Redacted]
License Classification: [Redacted]
License Expiration Date: [Redacted]
License Limit: [Redacted]

Masonry Contractor

(should subcontract portion be \$100,000 or greater, Tennessee Contractor License Information shall also be provided)

Name: N/A
License No.: N/A
License Classification: N/A
License Expiration Date: N/A
License Limit: N/A

Per Tennessee Department of Commerce & Insurance Board for Licensing Contractors Rule 0680-01-.24 (2): Award of the subcontract to one not listed on the base bid envelope in violation of T.C.A. § 52-5-119 will be subject to review and disciplinary action by the Board.

Contractor's Authorized Agent:

[Signature]
(Signature)

Contractor's Authorized Agent:

Jimmy Irwin
(Printed Name)

Received by Finance Office
10/16/2025 9:50am Kenny

AIA Document A310™ – 2010

Bid Bond

CONTRACTOR:

(Name, legal status and address)

Fellowship Construction, Inc.
2668 Spencer Mill Road
Bon Aqua, Tennessee 37025

SURETY:

(Name, legal status and principal place of business)

Old Republic Surety Company
PO Box 1635
Milwaukee, WI 53201-1635

This document has important legal consequences. Consultation with an attorney is encouraged with respect to its completion or modification.

Any singular reference to Contractor, Surety, Owner or other party shall be considered plural where applicable.

OWNER:

(Name, legal status and address)

Hickman County Board of Education
115 Murphree Ave
Centerville, TN 37033

BOND AMOUNT: Five Percent of the Total Amount Bid (5% of the Total Amount Bid)

PROJECT:

(Name, location or address, and Project number, if any)

East Hickman High School Ag Barn
7700 State HWY 7
Lyles, TN 37098

The Contractor and Surety are bound to the Owner in the amount set forth above, for the payment of which the Contractor and Surety bind themselves, their heirs, executors, administrators, successors and assigns, jointly and severally, as provided herein. The conditions of this Bond are such that if the Owner accepts the bid of the Contractor within the time specified in the bid documents, or within such time period as may be agreed to by the Owner and Contractor, and the Contractor either (1) enters into a contract with the Owner in accordance with the terms of such bid, and gives such bond or bonds as may be specified in the bidding or Contract Documents, with a surety admitted in the jurisdiction of the Project and otherwise acceptable to the Owner, for the faithful performance of such Contract and for the prompt payment of labor and material furnished in the prosecution thereof, or (2) pays to the Owner the difference, not to exceed the amount of this Bond, between the amount specified in said bid and such larger amount for which the Owner may in good faith contract with another party to perform the work covered by said bid, then this obligation shall be null and void, otherwise to remain in full force and effect. The Surety hereby waives any notice of an agreement between the Owner and Contractor to extend the time in which the Owner may accept the bid. Waiver of notice by the Surety shall not apply to any extension exceeding sixty (60) days in the aggregate beyond the time for acceptance of bids specified in the bid documents, and the Owner and Contractor shall obtain the Surety's consent for an extension beyond sixty (60) days.

If this Bond is issued in connection with a subcontractor's bid to a Contractor, the term Contractor in this Bond shall be deemed to be Subcontractor and the term Owner shall be deemed to be Contractor.

When this Bond has been furnished to comply with a statutory or other legal requirement in the location of the Project, any provision in this Bond conflicting with said statutory or legal requirement shall be deemed deleted herefrom and provisions conforming to such statutory or other legal requirement shall be deemed incorporated herein. When so furnished, the intent is that this Bond shall be construed as a statutory bond and not as a common law bond.

Signed and sealed this 16th day of October, 2025.

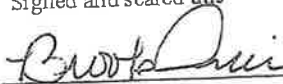

(Witness)

Fellowship Construction, Inc.
(Principal)  (Seal)

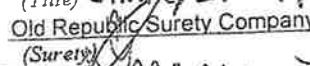
(Title) Jimmy Irwin, President

Old Republic Surety Company
(Surety) 

(Title) Gregory L. Bennett Jr., Attorney-in-Fact 

(Witness) Craig Whitlow, Partner

CAUTION: You should sign an original AIA Contract Document, on which this text appears in RED. An original assures that changes will not be obscured.

Init.

AIA Document A310™ – 2010. Copyright © 1963, 1970 and 2010 by The American Institute of Architects. All rights reserved. **WARNING:** This AIA Document is protected by U.S. Copyright Law and International Treaties. Unauthorized reproduction or distribution of this AIA Document, or any portion of it, may result in severe civil and criminal penalties, and will be prosecuted to the maximum extent possible under the law. Purchasers are permitted to reproduce ten (10) copies of this document when completed. To report copyright violations of AIA Contract Documents, e-mail The American Institute of Architects' legal counsel, copyright@aia.org. 061110



OLD REPUBLIC SURETY COMPANY

POWER OF ATTORNEY

KNOW ALL MEN BY THESE PRESENTS: That OLD REPUBLIC SURETY COMPANY, a Wisconsin stock insurance corporation, does make, constitute and appoint:

JAMES L. NOE III, CRAIG WHITLOW, GREGORY L. BENNETT JR., PAMELA PUSKARICH,
AMELIA CAIN, SETH CHAPMAN, ANDREW BENNETT, CHARLEY MYERS, JAMES MYERS of FRANKLIN, TN

its true and lawful Attorney(s)-in-Fact, with full power and authority for and on behalf of the company as surety, to execute and deliver and affix the seal of the company thereto (if a seal is required), bonds, undertakings, recognizances or other written obligations in the nature thereof, (other than bail bonds, bank depository bonds, mortgage deficiency bonds, mortgage guaranty bonds, guarantees of installment paper and note guaranty bonds, self-insurance workers compensation bonds guaranteeing payment of benefits, or black lung bonds), as follows:

ALL WRITTEN INSTRUMENTS

and to bind OLD REPUBLIC SURETY COMPANY thereby, and all of the acts of said Attorneys-in-Fact, pursuant to these presents, are ratified and confirmed. This appointment is made under and by authority of the board of directors at a special meeting held on February 18, 1982.

This Power of Attorney is signed and sealed by facsimile under and by the authority of the following resolutions adopted by the board of directors of the OLD REPUBLIC SURETY COMPANY on February 18, 1982.

RESOLVED that, the president, any vice-president or assistant vice president, in conjunction with the secretary or any assistant secretary, may appoint attorneys-in-fact or agents with authority as defined or limited in the instrument evidencing the appointment in each case, for and on behalf of the company to execute and deliver and affix the seal of the company to bonds, undertakings, recognizances, and suretyship obligations of all kinds; and said officers may remove any such attorney-in-fact or agent and revoke any Power of Attorney previously granted to such person.

RESOLVED FURTHER, that any bond, undertaking, recognizance, or suretyship obligation shall be valid and binding upon the Company

- (i) when signed by the president, any vice president or assistant vice president, and attested and sealed (if a seal be required) by any secretary or assistant secretary; or
- (ii) when signed by the president, any vice president or assistant vice president, secretary or assistant secretary, and countersigned and sealed (if a seal be required) by a duly authorized attorney-in-fact or agent;
- (iii) when duly executed and sealed (if a seal be required) by one or more attorneys-in-fact or agents pursuant to and within the limits of the authority evidenced by the Power of Attorney issued by the company to such person or persons.

RESOLVED FURTHER that the signature of any authorized officer and the seal of the company may be affixed by facsimile to any Power of Attorney or certification thereof authorizing the execution and delivery of any bond, undertaking, recognizance, or other suretyship obligations of the company; and such signature and seal when so used shall have the same force and effect as though manually affixed.

IN WITNESS WHEREOF, OLD REPUBLIC SURETY COMPANY has caused these presents to be signed by its proper officer, and its corporate seal to be affixed this 10th day of July, 2025.

[Signature]
Assistant Secretary



OLD REPUBLIC SURETY COMPANY
[Signature]
President

STATE OF WISCONSIN, COUNTY OF WAUKESHA - SS
On this 10th day of July, 2025, personally came before me, Alan Pavlic
and Kevin J. Abitz, to me known to be the individuals and officers of the OLD REPUBLIC SURETY COMPANY who executed the above instrument, and they each acknowledged the execution of the same, and being by me duly sworn, did severally depose and say: that they are the said officers of the corporation aforesaid, and that the seal affixed to the above instrument is the seal of the corporation, and that said corporate seal and their signatures as such officers were duly affixed and subscribed to the said instrument by the authority of the board of directors of said corporation.



[Signature]
Kathryn R. Pearson
Notary Public

My Commission Expires: September 28, 2026
(Expiration of notary's commission does not invalidate this instrument)

CERTIFICATE
I, the undersigned, assistant secretary of the OLD REPUBLIC SURETY COMPANY, a Wisconsin corporation, CERTIFY that the foregoing and attached Power of Attorney remains in full force and has not been revoked, and furthermore, that the Resolutions of the board of directors set forth in the Power of Attorney, are now in force.

87-1074



Signed and sealed at the City of Brookfield, WI this 16th day of October, 2025

[Signature]
Assistant Secretary

ORSC 22262 (3-06)

INSURANCE GROUP OF AMERICA LLC

BID FORM

TO: Hickman County Schools
Centerville, TN

PROJECT: Agricultural/Vocational Building at East Hickman County High School
7700 TN-7
Lyles, TN 37098

The undersigned as Bidder acknowledges by his signature that he has visited and examined the site of the proposed construction and has received and examined the documents titled Project Manual for the Construction of "Agricultural/Vocational Building at East Hickman County High School", the Drawings, and other documents dated July 18, 2025 and has included their provisions in his Bid. The Bidder further acknowledges that he has received the following Addenda:

Addendum No. _____	1	Dated	<u>10/09/2025</u>
Addendum No. _____		Dated	_____
Addendum No. _____		Dated	_____

In submitting this Bid, the Bidder agrees:

1. To hold open his Bid for 30 days from the date shown above.
2. To enter into and execute a Contract, if awarded, on the basis of this Bid, and to furnish the required Bonds and Insurance.
3. To accomplish Work in accord with the Contract Documents.
4. To complete the Work within 180 calendar days from and including the date of the Notice to Proceed.
5. Liquidated Damages will be assessed in the amount of five hundred dollars (\$500.00) per calendar day for failure to complete on time.

BASE BID

The Bidder agrees to construct the Work of the base bid for this project for the lump sum price of (show amount in both words and figures):

Five hundred eighty thousand dollars \$ 580,000.00

ALTERNATES – Not Applicable

UNIT PRICES – Not Applicable

The Bidder acknowledges by his signature that he agrees to requirements contained in the Invitation to Bid and the Instructions to Bidders and, that should he fail to execute a Contract with the Owner, should the Owner award said Contract to him, that the Owner may rightfully collect the sum of the Bid Bond.

Fellowship Construction, Inc.
Company

[Signature] Date 10/16/2025
Authorized Signature

NOTE: If Bidder is a corporation, Bid must be signed by an Officer of the Corporation licensed to bind the Corporation to this Agreement.

**ATTESTATION REGARDING PERSONNEL USED IN
CONTRACT/AGREEMENT PERFORMANCE**

SUBJECT AGREEMENT NUMBER:	Architect Project # 1402.1
ENGINEER'S LEGAL ENTITY NAME:	Fellowship Construction, Inc.
FEDERAL EMPLOYER IDENTIFICATION NUMBER: (or Social Security Number)	45-1139837

The Contractor/Engineer, identified above, does hereby attest, certify, warrant, and assure that the Contractor/Engineer shall not knowingly utilize the services of an illegal immigrant in the performance of this Agreement and shall not knowingly utilize the services of any subcontractor who will utilize the services of an illegal immigrant in the performance of this Agreement.

SIGNATURE & DATE:

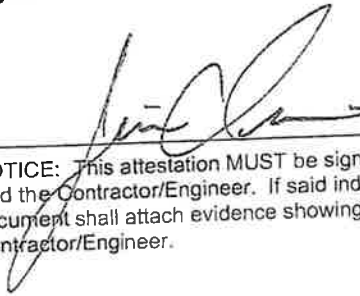
 10/16/2025

NOTICE: This attestation MUST be signed by an individual empowered to contractually bind the Contractor/Engineer. If said individual is not the chief executive or president, this document shall attach evidence showing the individual's authority to contractually bind the Contractor/Engineer.

9. REQUEST FOR TAXPAYER IDENTIFICATION NUMBER AND CERTIFICATION

Form **W-9**
(Rev. October 2018)
Department of the Treasury
Internal Revenue Service

Request for Taxpayer Identification Number and Certification

Give Form to the requester. Do not send to the IRS.

Go to www.irs.gov/FormW9 for instructions and the latest information.

Print or type. See Specific Instructions on page 3.

1 Name (as shown on your income tax return). Name is required on this line; do not leave this line blank.
Fellowship Construction, Inc.

2 Business name/disregarded entity name, if different from above

3 Check appropriate box for federal tax classification of the person whose name is entered on line 1. Check only one of the following seven boxes:

Individual/sole proprietor or single-member LLC

C Corporation

S Corporation

Partnership

Trust/estate

Limited liability company. Enter the tax classification (C=C corporation, S=S corporation, P=Partnership) ▶ _____

Note: Check the appropriate box in the line above for the tax classification of the single-member owner. Do not check LLC if the LLC is classified as a single-member LLC that is disregarded from the owner unless the owner of the LLC is another LLC that is not disregarded from the owner for U.S. federal tax purposes. Otherwise, a single-member LLC that is disregarded from the owner should check the appropriate box for the tax classification of its owner.

Other (see instructions) ▶ _____

4 Exemptions (codes apply only to certain entities, not individuals; see instructions on page 3):

Exempt payee code (if any) _____

Exemption from FATCA reporting code (if any) _____

(Applies to accounts maintained outside the U.S.)

5 Address (number, street, and apt. or suite no.) See instructions.
P.O. Box 310, 2668 Spencer Mill Rd

6 City, state, and ZIP code
Bon Aqua, TN 37025

7 List account number(s) here (optional)

Requester's name and address (optional)

Part I Taxpayer Identification Number (TIN)

Enter your TIN in the appropriate box. The TIN provided must match the name given on line 1 to avoid backup withholding. For individuals, this is generally your social security number (SSN). However, for a resident alien, sole proprietor, or disregarded entity, see the instructions for Part I, later. For other entities, it is your employer identification number (EIN). If you do not have a number, see *How to get a TIN*, later.

Note: If the account is in more than one name, see the instructions for line 1. Also see *What Name and Number To Give the Requester* for guidelines on whose number to enter.

Social security number

		-			-			
--	--	---	--	--	---	--	--	--

or

Employer identification number

4	5	-	1	1	3	9	8	3	7
---	---	---	---	---	---	---	---	---	---

Part II Certification

Under penalties of perjury, I certify that:

- The number shown on this form is my correct taxpayer identification number (or I am waiting for a number to be issued to me); and
- I am not subject to backup withholding because: (a) I am exempt from backup withholding, or (b) I have not been notified by the Internal Revenue Service (IRS) that I am subject to backup withholding as a result of a failure to report all interest or dividends, or (c) the IRS has notified me that I am no longer subject to backup withholding; and
- I am a U.S. citizen or other U.S. person (defined below); and
- The FATCA code(s) entered on this form (if any) indicating that I am exempt from FATCA reporting is correct.

Certification instructions. You must cross out item 2 above if you have been notified by the IRS that you are currently subject to backup withholding because you have failed to report all interest and dividends on your tax return. For real estate transactions, item 2 does not apply. For mortgage interest paid, acquisition or abandonment of secured property, cancellation of debt, contributions to an individual retirement arrangement (IRA), and generally, payments other than interest and dividends, you are not required to sign the certification, but you must provide your correct TIN. See the instructions for Part II, later.

Sign Here	Signature of U.S. person ▶ 	Jimmy Irwin, President	Date ▶ 10/16/2025
-----------	--	------------------------	-------------------

General Instructions

Section references are to the Internal Revenue Code unless otherwise noted.

Future developments. For the latest information about developments related to Form W-9 and its instructions, such as legislation enacted after they were published, go to www.irs.gov/FormW9.

Purpose of Form

An individual or entity (Form W-9 requester) who is required to file an information return with the IRS must obtain your correct taxpayer identification number (TIN) which may be your social security number (SSN), individual taxpayer identification number (ITIN), adoption taxpayer identification number (ATIN), or employer identification number (EIN), to report on an information return the amount paid to you, or other amount reportable on an information return. Examples of information returns include, but are not limited to, the following.

- Form 1099-INT (interest earned or paid)

- Form 1099-DIV (dividends, including those from stocks or mutual funds)
 - Form 1099-MISC (various types of income, prizes, awards, or gross proceeds)
 - Form 1099-B (stock or mutual fund sales and certain other transactions by brokers)
 - Form 1099-S (proceeds from real estate transactions)
 - Form 1099-K (merchant card and third party network transactions)
 - Form 1098 (home mortgage interest), 1098-E (student loan interest), 1098-T (tuition)
 - Form 1099-C (canceled debt)
 - Form 1099-A (acquisition or abandonment of secured property)
- Use Form W-9 only if you are a U.S. person (including a resident alien), to provide your correct TIN.

If you do not return Form W-9 to the requester with a TIN, you might be subject to backup withholding. See What is backup withholding, later.

**SECTION 00200
FORM OF PROPOSAL**

8. CONTRACTOR/SUBCONTRACTOR CONTACT INFORMATION

Company Name: Fellowship Construction, Inc

Please provide the requested information for each representative of your company responsible for the positions or areas listed below:
This information must be submitted with the bid.

CONTRACT ADMINISTRATOR

NAME: Jamie Irwin
ADDRESS: P.O. Box 310
Bon Aqua, TN 37025
PHONE: (615) 412-4446
EMAIL: jirwin@fellowshipconstruction.com

SITE SUPERINTENDENT

NAME: Steve Davis, Mark Allen or Chris Brown
ADDRESS: P.O. Box 310
Bon Aqua, TN 37025
PHONE: (615) 412-4446
EMAIL: _____

CERTIFICATES OF INSURANCE

NAME: Brooke Irwin
ADDRESS: P.O. Box 310
Bon Aqua, TN 37025
PHONE: (615) 412-4446
EMAIL: birwin@fellowshipconstruction.com

PROJECT MANAGER

NAME: Jamie Irwin
ADDRESS: P.O. Box 310
Bon Aqua, TN 37025
PHONE: (615) 412-4446
EMAIL: jirwin@fellowshipconstruction.com

CERTIFIED PAYROLLS

NAME: Brooke Irwin
ADDRESS: P.O. Box 310
Bon Aqua, TN 37025
PHONE: (615) 412-4446
EMAIL: birwin@fellowshipconstruction.com

ESTIMATOR /CHANGE ORDER PRICING

NAME: Jamie Irwin
ADDRESS: P.O. Box 310
Bon Aqua, TN 37025
PHONE: (615) 412-4446
EMAIL: jirwin@fellowshipconstruction.com

PAY APPLICATIONS

NAME: Jamie Irwin
ADDRESS: P.O. Box 310
Bon Aqua, TN 37025
PHONE: (615) 412-4446
EMAIL: jirwin@fellowshipconstruction.com

**CHANGE ORDER ADMINISTRATOR
(IF NOT PROJECT MANAGER)**

NAME: Jamie Irwin
ADDRESS: P.O. Box 310
Bon Aqua, TN 37025
PHONE: (615) 412-4446
EMAIL: jirwin@fellowshipconstruction.com

**SECTION 00200
FORM OF PROPOSAL**

**7. IDENTIFICATION OF SMALL, MINORITY, WOMEN, AND VETERAN OWNED BUSINESS
BIDDER/CONTRACTOR, SUBCONTRACTOR, AND MATERIAL SUPPLIER**

Utilization of Small, Minority, Women, and Veteran owned contracting and material supplier businesses is encouraged and supported whenever possible on public school projects.

This form should be submitted, along with other documents required within (4 days) of Bid Opening.

Bidder Fellowship Construction, Inc. is a (circle applicable: **SBE**, MBE, WBE, VOSB, not applicable)

The following Small, Minority, Women, or Veteran Owned business will be providing subcontracting or supplying materials as part of the bid by Fellowship Construction, Inc.
Insert Name of Entity submitting Bid

Business Name	City, State	SBE, MBE, WBE, VOSB, (other)
N/A		

The following Small, Minority, Women, or Veteran Owned businesses were contacted to obtain proposals when the bid submitted by Fellowship Construction, Inc.
was being prepared. Insert Name of Entity submitting Bid

Business Name	City, State	SBE, MBE, WBE, VOSB, (other)
Nickell Company, LLC.	Columbia, TN	SBE, WBE
Crawford Door Sales of Nashville	Nashville, TN	SBE
Commercial Installation, LLC.	Clarksville, TN	MBE
Wall Brothers Glass, LLC.	Clarksville, TN	SBE
Isenhour Door Products	Nashville, TN	SBE
Slayden Door & Hardware	La Vergne, TN	SBE
Planet Glass	Columbia, TN	MBE
C & R Services, Inc.	Nashville, TN	SBE, WBE
Parthenon Plumbing	Nashville, TN	SBE
American Comm. Indus. Electric	Nashville TN	SBE
Maryland Electric Company, LLC.	Kingston Springs, TN	WBE
Crown Paving	Greenbrier, TN	WBE
Sessions Paving Company	Nashville, TN	SBE



**STATE OF TENNESSEE
NON-BOYCOTT OF ISRAEL CERTIFICATION**

The Bidder certifies that it is not currently engaged in, and will not for the duration of the contract engage in, a boycott of Israel as defined by Tenn. Code Ann. § 12-4-119. This provision shall not apply to contracts with a total value of less than two hundred fifty thousand dollars (\$250,000) or to contractors with less than ten (10) employees.

According to the law, a boycott of Israel means engaging in refusals to deal, terminating business activities, or other commercial actions that are intended to limit commercial relations with Israel, or companies doing business in or with Israel or authorized by, licensed by, or organized under the laws of the State of Israel to do business, or persons or entities doing business in Israel, when such actions are taken:

- 1) In compliance with, or adherence to, calls for a boycott of Israel, or
- 2) In a manner that discriminates on the basis of nationality, national origin, religion, or other unreasonable basis, and is not based on a valid business reason. Tenn. Code Ann. § 12-4-119.

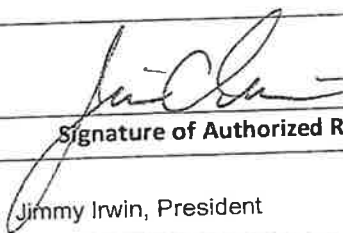
	10/16/2025
Signature of Authorized Representative	Date
Jimmy Irwin, President	(615) 412-4446 jirwin@fellowshipconstruction.com
Printed Name	Phone Number / Email Address



**STATE OF TENNESSEE
IRAN DIVESTMENT ACT CERTIFICATION**

SUBJECT CONTRACT NUMBER(S):	Architect's Project No. 1402.1
CONTRACTOR LEGAL ENTITY NAME:	Fellowship Construction, Inc.
EDISON SUPPLIER IDENTIFICATION NUMBER:	

The Iran Divestment Act, Tenn. Code Ann. § 12-12-101 et. seq. requires a person that attempts to contract with the state, including a contract renewal or assumption, to certify at the time the bid is submitted or the contract is entered into, renewed, or assigned, that the person or the assignee is not identified on a list created pursuant to § 12-12-106.

Currently, the list is available online at the following website: <https://www.tn.gov/generalservices/procurement/central-procurement-office--cpo-/library-/public-information-library.html>

The Contractor, identified above, certifies by signature below that it is not included on the list of persons created pursuant to Tenn. Code Ann. § 12-12-106 of the Iran Divestment Act.



CONTRACTOR SIGNATURE

NOTICE: This certification MUST be signed by an individual with legal capacity to contractually bind the Contractor.

Jimmy Irwin, President

PRINTED NAME AND TITLE OF SIGNATORY

10/16/2025

DATE

SECTION 00200
FORM OF PROPOSAL

6. CONFLICT OF INTEREST

CONFLICT OF INTEREST

Hickman County Government

Conflict of Interest Disclosure Form

The County Financial Management System of 1981 contains the most stringent conflict of interest provisions. TCA §5-21-121 provides:

- (a) The director, purchasing agent, members of the committee, members of the county legislative body or other officials, employees, or members of the board of education or highway commission shall not be financially interested or have any personal beneficial interest, either directly or indirectly, in the purchase of any supplies, materials, equipment or contractual services for the county.
- (b) No firm, corporation, partnership, association, or individual furnishing any such supplies, materials, equipment or contractual services shall give or offer, nor shall the director or purchasing agent or any assistant or employee accept or receive directly or indirectly from any person, firm, corporation, partnership, or association to whom any contract may be awarded by rebate, gift or otherwise, any money or other things of value whatsoever, or any promise, obligation or contract for future reward or compensation.

Date: 10/16/2025 Name: Fellowship Construction, Inc. - Jimmy Irwin President

Please describe below any relationships, transactions, positions you hold (volunteer or otherwise) or circumstances that you believe could contribute to a conflict of interest:

X I have no conflict of interest to report.

I have the following conflict of interest to report (please specify any boards or committees you (and/or your spouse) sit on, the name of your employer and any business you or your spouse may own.

I hereby certify that the information set forth above is true and complete to the best of my knowledge.

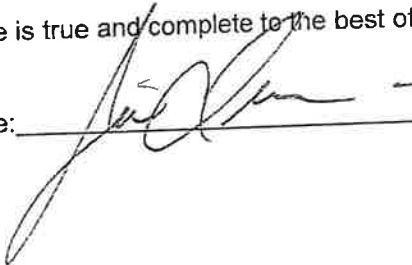
Date: 10/16/2025 Signature: 

EAST HICKMAN HIGH SCHOOL AGRICULTURAL/VOCATIONAL EDUCATION BOARD OF EDUCATION HICKMAN COUNTY BOARD OF EDUCATION

9111 ADDRESS 7700 TN-7 HIGHWAY
LYLES, HICKMAN COUNTY, TENNESSEE

September 05, 2025



PROPERTY INFORMATION
OWNER/DEVELOPER HICKMAN COUNTY BOARD OF EDUCATION
9111 ADDRESS 7700 TN-7 HIGHWAY
CHERRYVILLE, TENNESSEE 37023

ENGINEER
SOUTHERN CONSULTING
12081 HIGHWAY 41E
KNOXVILLE, TENNESSEE 37905

DATUM INFORMATION
STATE PLANE COORDINATE SYSTEM - TENNESSEE
NAD 83
GEOIDIC DATUM
GEOIDAL DATUM
GEOIDAL DATUM

FEDERAL FLOOD NOTE
THIS PROPERTY IS NOT LOCATED WITHIN THE 100
YEAR FLOODPLAIN AS SHOWN ON THE
FEDERAL CENSUS BUREAU OF ECONOMIC MAP
NO. 4108100000. LETTER DATE 7/16/2008

Sheet Number	Sheet Title
C0.0	TITLE SHEET
C1.0	DEMOLITION PLAN
C2.0	SITE & UTILITY PLAN
C3.0	GRADING PLAN
C4.0	DETAIL SHEET



LYLE COOK-MARTIN
ARCHITECTS
370 Franklin Street / Clarksville, TN 37040
TEL: 931.552.4771 / email: lmartin@lylecookmartin.com

EAST HICKMAN HIGH SCHOOL
AGRICULTURAL/VOCATIONAL
EDUCATION BUILDING
LYLES, TENNESSEE
TITLE SHEET

Project No.	1402.1
Issue Date	07/18/2025
Drawn By	DKM
Revision Date	09/05/2025
Revision Description	

Sheet No. **C0.0**



Southern Consulting
Engineering & Architectural Services
12081 HIGHWAY 41E, KNOXVILLE, TN 37905
800.749.0171 | 615.411.0171

1402.1
 07/18/2025
 DKW
 09/05/2025
 Revision Date
 Revision Date
 Revision Date

**EAST HICKMAN HIGH SCHOOL
 AGRICULTURAL/VOCATIONAL
 EDUCATION BUILDING
 LYLES, TENNESSEE
 DEMOLITION PLAN**

LYLE COOK MARTIN
 ARCHITECTS
 310 Franklin Street / Clarksville, TN 37040
 TEL: 931.552.4771 / email: lmartin@lylecookmartin.com



Southern Consulting
 Engineering & Construction Services
 1000 W. Highway 40E, Hickman, TN 37050
 615.750.5171 | www.southernct.com

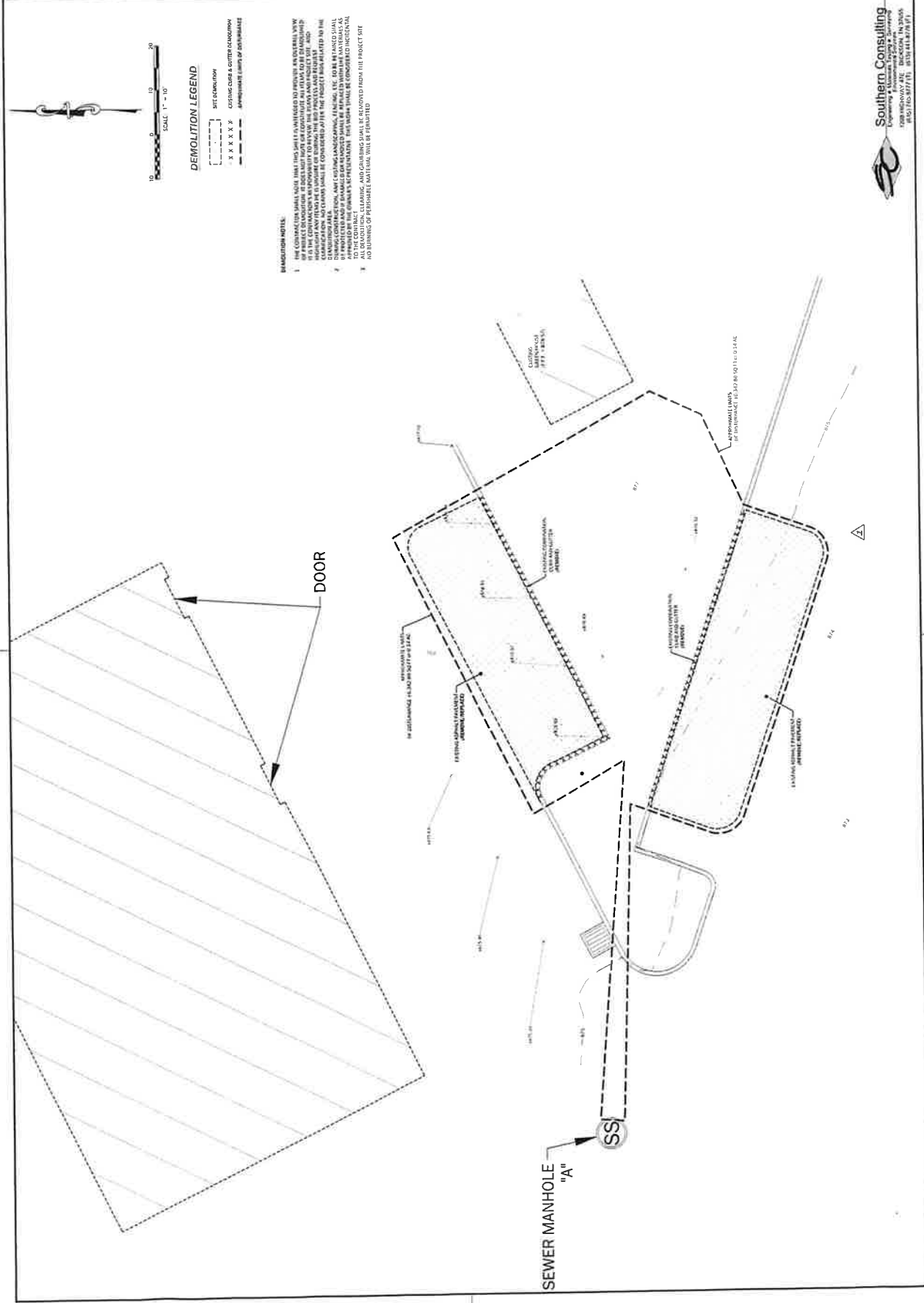

DEMOLITION NOTE:

- THE CONTRACTOR SHALL NOTE THAT THIS SHEET IS INTENDED TO PROVIDE AN OVERALL VIEW OF THE PROJECT DEMOLITION. IT DOES NOT PROVIDE AN EXHAUSTIVE ANALYSIS OF THE EXISTING STRUCTURE OR THE DEMOLITION PROCESS. ANY ITEMS TO BE DEMOLISHED OR REMOVED SHOULD BE IDENTIFIED BY THE CONTRACTOR AND THE DEMOLITION AREA SHOULD BE IDENTIFIED BY THE CONTRACTOR. THE CONTRACTOR SHALL BE RESPONSIBLE FOR OBTAINING ALL NECESSARY PERMITS AND APPROVALS FROM THE LOCAL, STATE, AND FEDERAL AUTHORITIES. THE CONTRACTOR SHALL BE RESPONSIBLE FOR OBTAINING ALL NECESSARY PERMITS AND APPROVALS FROM THE LOCAL, STATE, AND FEDERAL AUTHORITIES. THE CONTRACTOR SHALL BE RESPONSIBLE FOR OBTAINING ALL NECESSARY PERMITS AND APPROVALS FROM THE LOCAL, STATE, AND FEDERAL AUTHORITIES.
- ALL DEMOLITION, CLEARING, AND GRUBBING SHALL BE COMPLETED FROM THE PROJECT SITE AND SHOWN ON SEPARATE SHEETS TO BE SUBMITTED.

DEMOLITION LEGEND

- SITE BOUNDARY
- - - - - EXISTING CONCRETE
- - - - - EXISTING MASONRY

SCALE: 1" = 30'





LYLE COOK MARTIN
ARCHITECTS

310 Franklin Street / Clarksville, TN 37040
TEL: 831.552.4771 / email: bmartin@lylecookmartin.com

EAST HICKMAN HIGH SCHOOL
AGRICULTURAL/VOCATIONAL
EDUCATION BUILDING
LYLES, TENNESSEE
SITE & UTILITY PLAN

Project No.	1402.1
Issue Date	07/18/2025
Drawn By	DKM
Revision Date	09/05/2025

C2.0

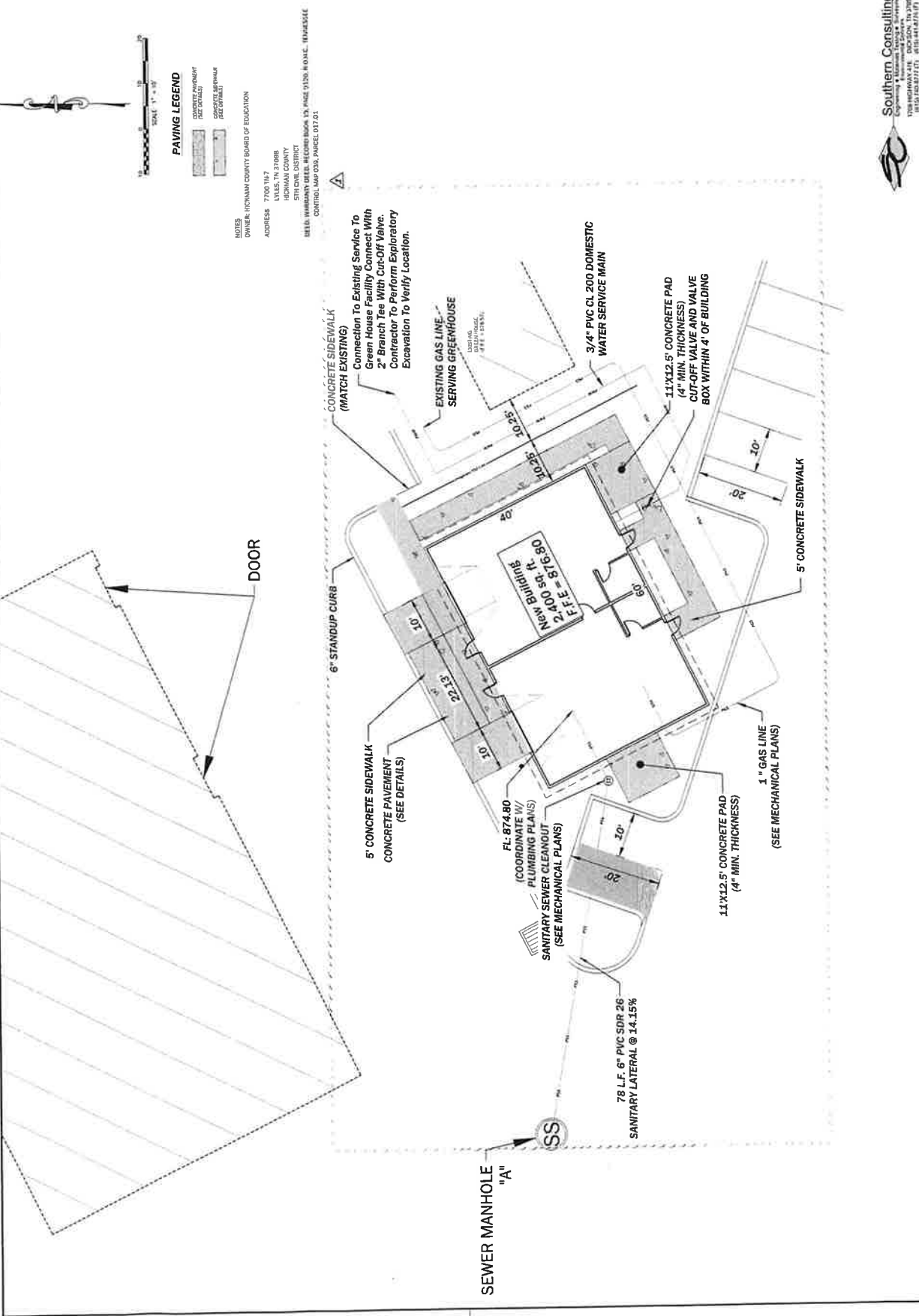

PAVING LEGEND

	CONCRETE SIDEWALK (SEE DETAILS)
	CONCRETE PAVEMENT (SEE DETAILS)

NOTES:
OWNER: HICKMAN COUNTY BOARD OF EDUCATION
ADDRESS: 7100 TN-7
HICKMAN COUNTY
5TH CIVIL DISTRICT
FIELD WARRANTS DEED RECORD BOOK 15 PAGE 9150 HICKMAN, TENNESSEE
CONTROL MAP 035, PARCEL 017.01





Project No: 1402.1
 Issue No: 07/18/2025
 Designer: CJC
 Date: 07/18/2025
 Revision: 1402.1

**EAST HICKMAN HIGH SCHOOL
 AGRICULTURAL/VOCATIONAL
 LYLES, TENNESSEE
 FLOOR PLAN, REFLECTED CEILING & ROOF PLAN**

**LYLE COOK MARTIN
 ARCHITECTS**
 310 Franklin Street / Cookeville, TN 37008
 TEL: 931.652.4771 / email: bmartin@lylecookmartin.com

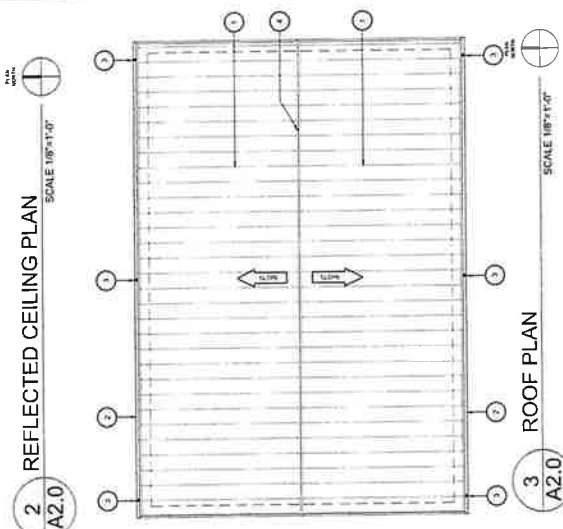
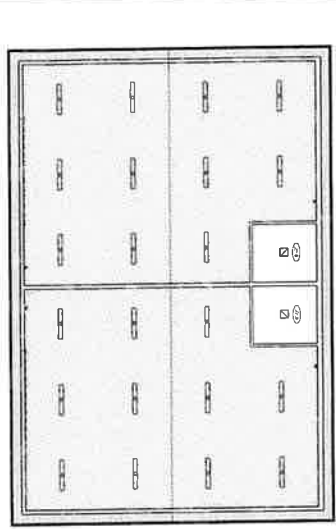

- KEY NOTES TO ROOF PLAN**
- 1 STANDING SEAM METAL ROOF SYSTEM, COLOR TO BE CALVALINI
 - 2 PVI FINISHED CONTINUOUS METAL GUTTER
 - 3 PVI FINISHED METAL DOWNSPOUTS
 - 4 METAL RIDGE CAP TO MATCH ROOF PANELS WITH CEILING PANELS

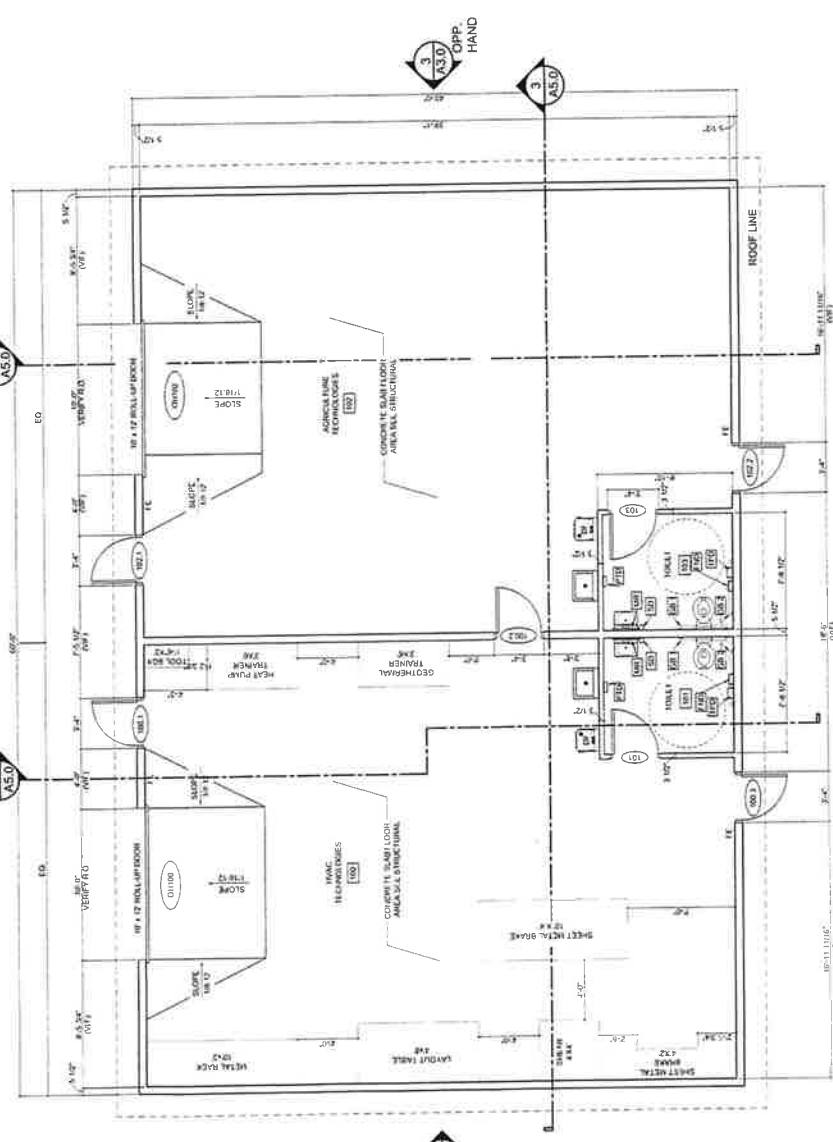

- CEILING LEGEND**
- PAINTED PLYWOOD CEILING
 - EXPOSED CEILING
 - CORRUGATED METAL SOFFIT
 - LINEAR SURFACE MOUNTED LIGHT FIXTURE
 - SURFACE MOUNTED LIGHT FIXTURE
 - EMERGENCY EGRESS WALL MOUNTED LIGHT FIXTURE

- GENERAL NOTES**
1. FOR TOILET ACCESSORIES AND MOUNTING HEIGHTS REF. A3.0
 2. UTILITY SINK TO BE IN EACH TECHNOLOGY SPACE. ALLOW FOR 1'-0" CLEARANCE FROM WALL TO OE FIXTURE AND A MINIMUM OF 2'-0" BETWEEN OUTSIDE EDGE OF WATER COOLER AND OUTSIDE EDGE OF FIXTURE.
- WALL LEGEND**
- EXTERIOR WALL - 2x6 WOOD STUD FRAMING
 - INTERIOR STUD WALL (2X6 WOOD STUD FRAMING WITH 3" SOUND BATT INSULATION AT CENTER WALL, 2X4 WOOD STUD FRAMING WITH 3" SOUND BATT INSULATION AT TOILET ROOM WALLS & CEILING FRAMING)



LYLE·COOK·MARTIN
ARCHITECTS
310 Franklin Street / Clarksville, TN 37040
TEL 931.552.4771 / email: bmartin@lylecookmartin.com

**EAST HICKMAN HIGH SCHOOL
EDUCATIONAL BUILDING
LYLES, TENNESSEE**
ELEVATIONS & SCHEDULES

1402.1
07/18/2025
CJC

A3.0

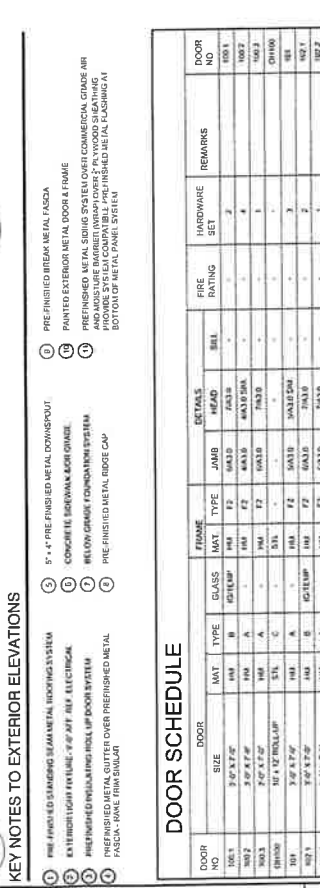
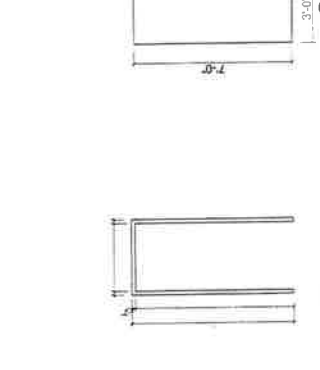
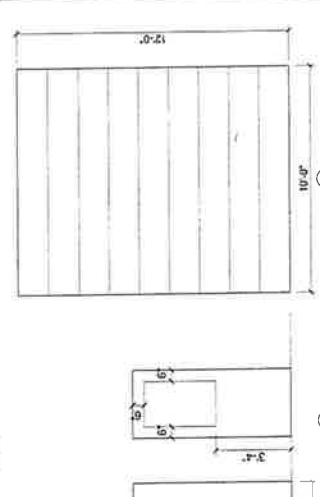
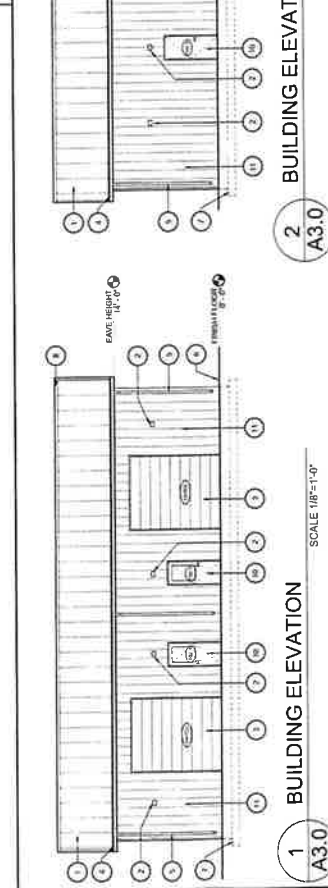
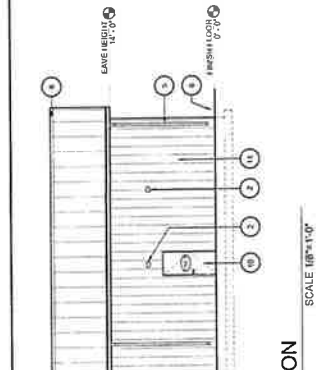
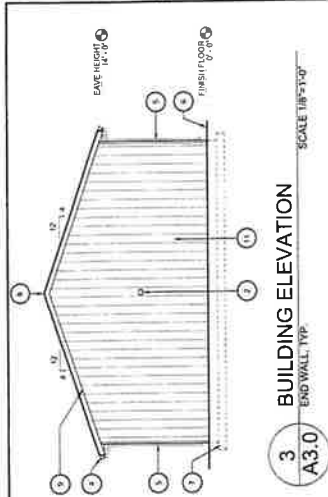

KEY NOTES TO EXTERIOR ELEVATIONS

- PRE-FINISHED STANDING SEAM METAL ROOFING SYSTEM
- EXTERIOR LIGHT FIXTURES, 2' x 2' AIA ELECTRICAL
- PRE-FINISHED INSULATING SECTIONAL ROLL-UP DOOR SYSTEM
- PRE-FINISHED METAL GUTTER OVER PRE-FINISHED METAL FLASHING AT BOTTOM OF METAL PANEL SYSTEM
- PRE-FINISHED METAL ROSE CAP
- PRE-FINISHED METAL JAMB
- PRE-FINISHED METAL DOOR & FRAME
- CONCRETE TROWEL FINISH CONCRETE
- 5' x 4' PRE-FINISHED METAL DOWNSPOUT
- PRE-FINISHED BREAK METAL FLASH
- PAINTED EXTERIOR METAL DOOR & FRAME
- PRE-FINISHED METAL SIDING SYSTEM OVER COMMERCIAL GRADE AIR AND MOISTURE BARRIER WITH 2\"/>

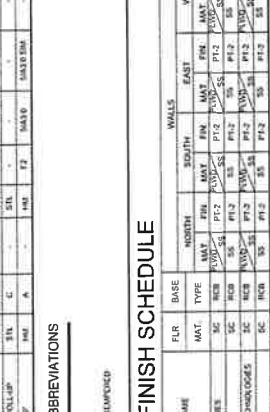
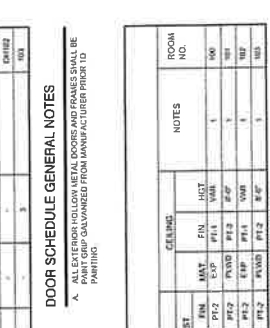
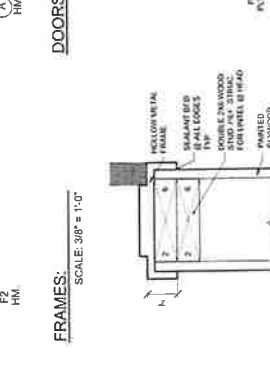
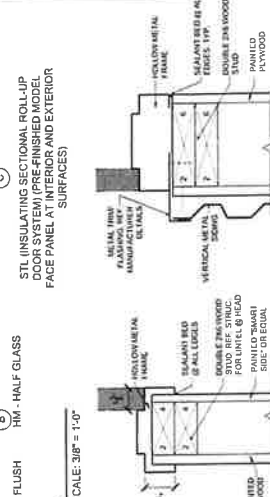

DOORS: SCALE 3/8" = 1'-0"

FRAMES: SCALE 3/8" = 1'-0"

DOOR SCHEDULE GENERAL NOTES

- ALL EXTERIOR HOLLOW METAL DOORS AND FRAMES SHALL BE PAINTED GALVANNEED FROM MANUFACTURER PRIOR TO FINISHING.

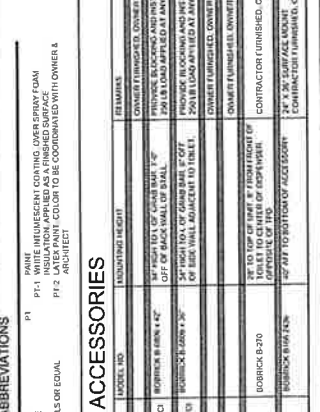
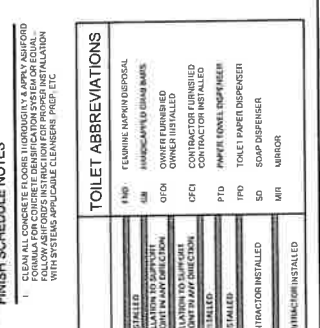
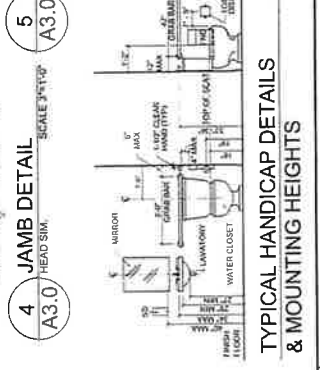
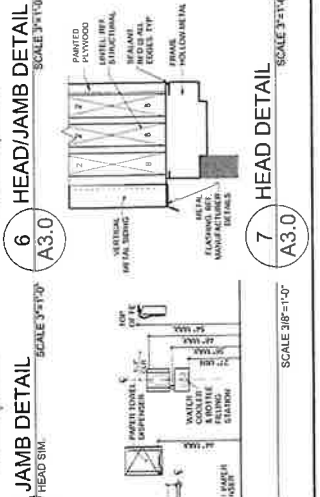

DOOR SCHEDULE

DOOR NO.	SIZE	GLASS	TYPE	JAMB	DETAILS	FINISH	REMARKS
100.1	2'-0" x 7'-0"	1/2" GLASS	1/2"	1/2"	1/2"	1/2"	1/2"
100.2	2'-0" x 7'-0"	1/2" GLASS	1/2"	1/2"	1/2"	1/2"	1/2"
100.3	2'-0" x 7'-0"	1/2" GLASS	1/2"	1/2"	1/2"	1/2"	1/2"
100.4	2'-0" x 7'-0"	1/2" GLASS	1/2"	1/2"	1/2"	1/2"	1/2"
100.5	2'-0" x 7'-0"	1/2" GLASS	1/2"	1/2"	1/2"	1/2"	1/2"
100.6	2'-0" x 7'-0"	1/2" GLASS	1/2"	1/2"	1/2"	1/2"	1/2"
100.7	2'-0" x 7'-0"	1/2" GLASS	1/2"	1/2"	1/2"	1/2"	1/2"
100.8	2'-0" x 7'-0"	1/2" GLASS	1/2"	1/2"	1/2"	1/2"	1/2"
100.9	2'-0" x 7'-0"	1/2" GLASS	1/2"	1/2"	1/2"	1/2"	1/2"
100.10	2'-0" x 7'-0"	1/2" GLASS	1/2"	1/2"	1/2"	1/2"	1/2"
100.11	2'-0" x 7'-0"	1/2" GLASS	1/2"	1/2"	1/2"	1/2"	1/2"
100.12	2'-0" x 7'-0"	1/2" GLASS	1/2"	1/2"	1/2"	1/2"	1/2"
100.13	2'-0" x 7'-0"	1/2" GLASS	1/2"	1/2"	1/2"	1/2"	1/2"

ROOM FINISH SCHEDULE

ROOM NO.	ROOM NAME	FLOOR	BASE	NORTH WALLS	EAST WALLS	WEST WALLS	CEILING	NOTES
100	CLASSROOM	1ST	1/2"	1/2"	1/2"	1/2"	1/2"	1/2"
101	LABORATORY	1ST	1/2"	1/2"	1/2"	1/2"	1/2"	1/2"
102	OFFICE	1ST	1/2"	1/2"	1/2"	1/2"	1/2"	1/2"
103	TOILET	1ST	1/2"	1/2"	1/2"	1/2"	1/2"	1/2"

FINISH SCHEDULE ABBREVIATIONS

1. CEILING: P1 WHITE INFLUORESCENT COATING OVER SPRAY FOAM
2. FLOOR: P1 POLYURETHANE FLOORING
3. WALLS: P1 1/2" GYPSUM BOARD
4. ROOF: P1 5" POLYURETHANE INSULATION OVER 1/2" GYPSUM BOARD
5. EXTERIOR: P1 1/2" GYPSUM BOARD OVER 1/2" GYPSUM BOARD
6. INTERIOR: P1 1/2" GYPSUM BOARD OVER 1/2" GYPSUM BOARD
7. CEILING: P1 1/2" GYPSUM BOARD
8. FLOOR: P1 POLYURETHANE FLOORING
9. WALLS: P1 1/2" GYPSUM BOARD
10. ROOF: P1 5" POLYURETHANE INSULATION OVER 1/2" GYPSUM BOARD
11. EXTERIOR: P1 1/2" GYPSUM BOARD OVER 1/2" GYPSUM BOARD
12. INTERIOR: P1 1/2" GYPSUM BOARD OVER 1/2" GYPSUM BOARD

TOILET ACCESSORIES

TOILET TYPE/ACCESSORY	MODEL NO.	REMARKS
TOILET	100	TOILET
SINK	100	SINK
MIRROR	100	MIRROR
DISPENSER	100	DISPENSER

TYPICAL HANDICAP DETAILS & MOUNTING HEIGHTS SCALE 3/8" = 1'-0"



LYLE·COOK·MARTIN
ARCHITECTS
 310 Franklin Street / Clarksville, TN 37040
 TEL 931.552.4771 / email: lmartin@lylecookmartin.com

EAST HICKMAN HIGH SCHOOL
AGRICULTURAL VOCATIONAL
EDUCATION BUILDING
LYLES, TENNESSEE
BUILDING SECTIONS

Project No: 1402.1
 Issue Date: 07/18/2025
 Client: CJC
 Revision Date: 09.05.2025

A4.0

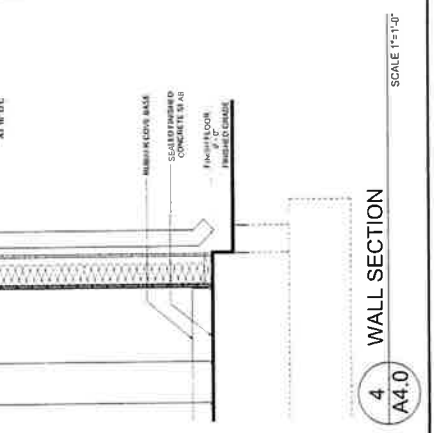
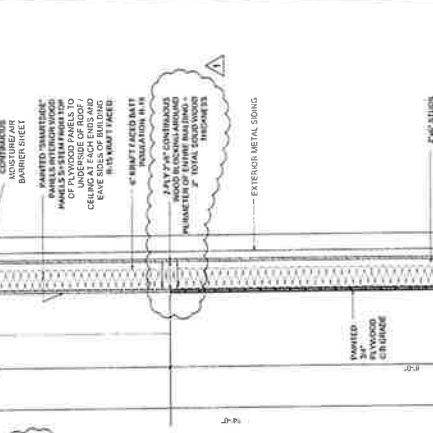
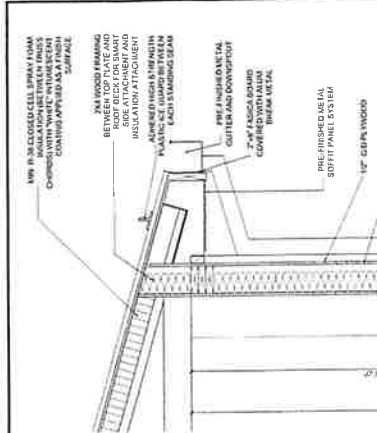

KEY NOTES TO BUILDING SECTIONS

- PRE FINISHED STANDING SEAM METAL ROOFING SYSTEM
- INSULATED END WALLS FROM FLOOR TO UNDER EDGE OF ROOF DECK - EA. SIDE
- MIN 3/4" RIGID CLOSED CELL SPRAY FOAM INSULATION WITH FINISH COAT AND APPLIED AS A FINISH UNDER COVER SPRAY FOAM
- WOODEN TRUSS SYSTEM REF. STRUCTURAL
- PAINTED 2x4 WOOD REF. FINISH SCHEDULE
- PAINTED 2x4 WOOD REF. FINISH SCHEDULE
- PRE FINISHED METAL GUTTER & DOWNSPOUT
- CORRUGATED METAL SOFFIT
- 2x4 CEILING JOIST @ 16" O.C. TYP. REF. STRUCTURAL
- 4" RUBBER CORE BASE
- UNITEL REF. STRUCTURAL
- 2x6 WOOD FRAMED WALL WITH 2" SOUND BATT INSULATION IN ENTIRE WALL FROM START TO ROOF DECK

NOTES TO FLOOR SLAB INSULATION

INSTALL 1/2" THICK CONTINUOUS EXTRUDED FOAM PERIMETER SLAB INSULATION AT ENTIRE EDGE OF SLAB. FOR FACE OF ALL FOUNDATION WALLS BELOW SLAB AND EXTEND A MIN 2' OFF HORIZONTALLY UNDER FLOOR SLAB ALL AROUND BUILDING.

4 WALL SECTION
 SCALE 1/4"=1'-0"
A4.0

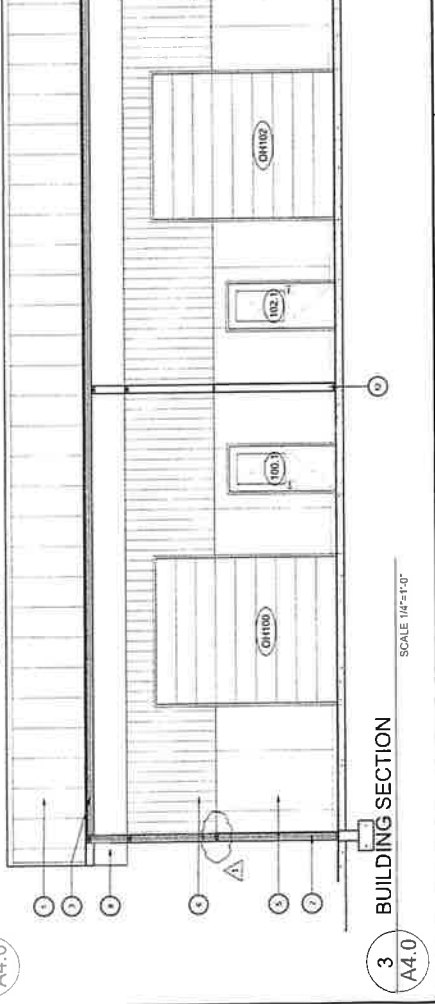
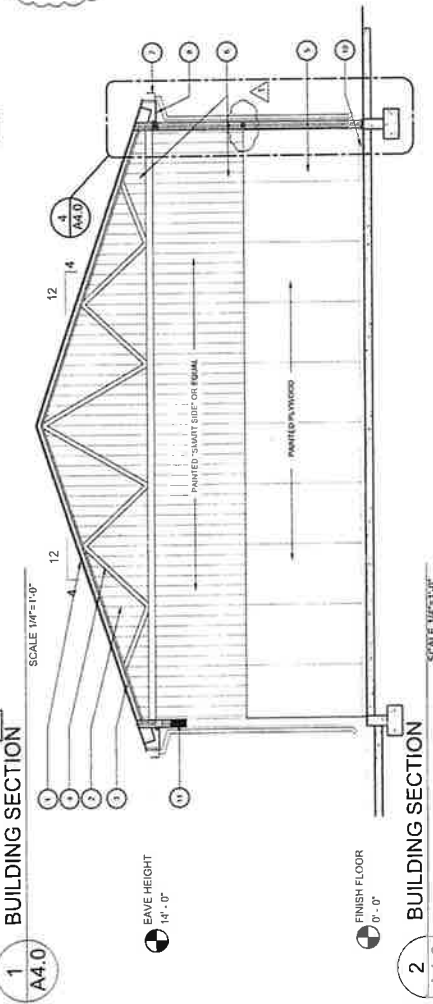
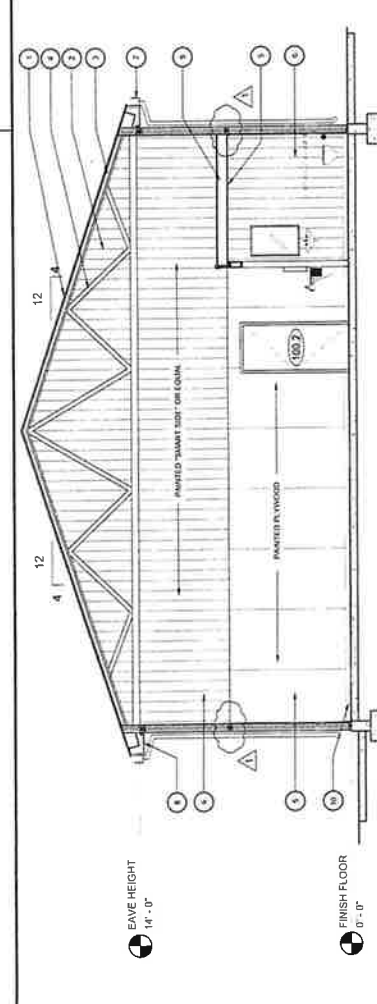

1 BUILDING SECTION
 SCALE 1/4"=1'-0"
A4.0

2 BUILDING SECTION
 SCALE 1/4"=1'-0"
A4.0

3 BUILDING SECTION
 SCALE 1/4"=1'-0"
A4.0

Revision No.	1402.1
Revision Date	7.18.2025
Revision By	BKS
Revision Description	

**EAST HICKMAN HIGH SCHOOL
AGRICULTURAL/VOCATIONAL
EDUCATION BUILDING
LYLES, TENNESSEE**

**LYLE·COOK·MARTIN
ARCHITECTS**
310 Franklin Street / Clarksville, TN 37040
TEL 931.552.4771 / email: bmartin@lylecookmartin.com

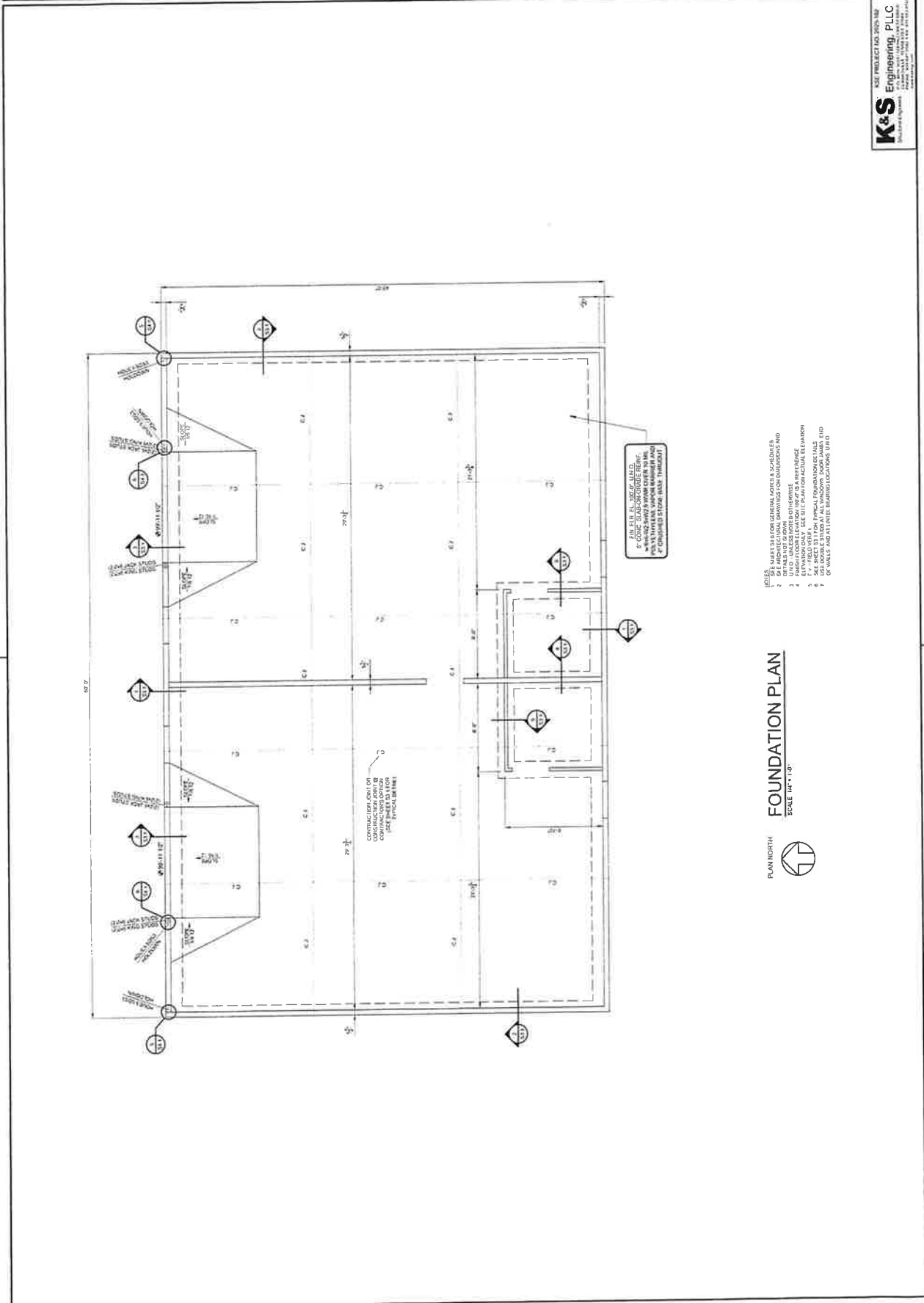

- NOTES**
1. SEE SUBMITTALS FOR GENERAL NOTES & SCHEDULES
 2. DETAILS NOT SHOWN SHALL BE AS SHOWN ON DRAWINGS
 3. FOUNDATION SHALL BE CONFORM TO TYPICAL FOUNDATION
 4. FOUNDATION SHALL BE CONFORM TO TYPICAL FOUNDATION
 5. F.V. FIELD VISION - SEE SCHEDULE FOR WINDOW SCHEDULE
 6. USE DOUBLE STOPS AT ALL WINDOWS, DOOR LAMBS, ETD
 7. 0" WALLS AND PARTIAL WALLS LOCATIONS UNID

FOUNDATION PLAN
SCALE 1/4" = 1'-0"





LYLE·COOK·MARTIN
ARCHITECTS
310 Franklin Street / Clarksville, TN 37040
TEL 931.552.4771 / email: dmartin@lylecookmartin.com

**EAST HICKMAN HIGH SCHOOL
AGRICULTURAL/VOCATIONAL
BUILDING, TENNESSEE
ROOF FRAMING PLAN**

PROJECT NO.	1402.1
DATE	7.18.2025
DESIGNER	BKS
REVISION DATE	
REVISION DESCRIPTION	

S2.1
SHEET NO.

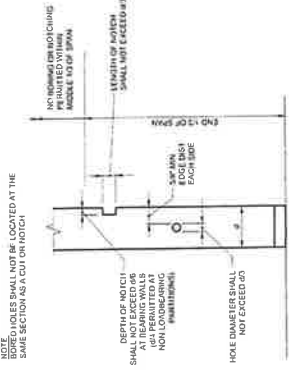

DETAIL STUD NOTCHING & BORING LIMITS
SCALE: 1/4"=1'-0"

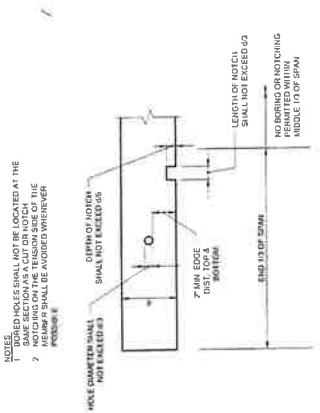

DETAIL JOIST NOTCHING & BORING LIMITS
SCALE: 1/4"=1'-0"

NOTES:
1 BORED HOLES SHALL NOT BE LOCATED AT THE CENTER OF THE TRUSS OR JOIST.
2 NO NOTCHING ON THE TENSION SIDE OF THE TRUSS OR JOIST SHALL BE ALLOWED WHEREVER PERMITTED.

LEGEND:
(LI) UNLESS NOTED OTHERWISE, SEE SHEET S1.0 FOR MEMBER SCHEDULE.

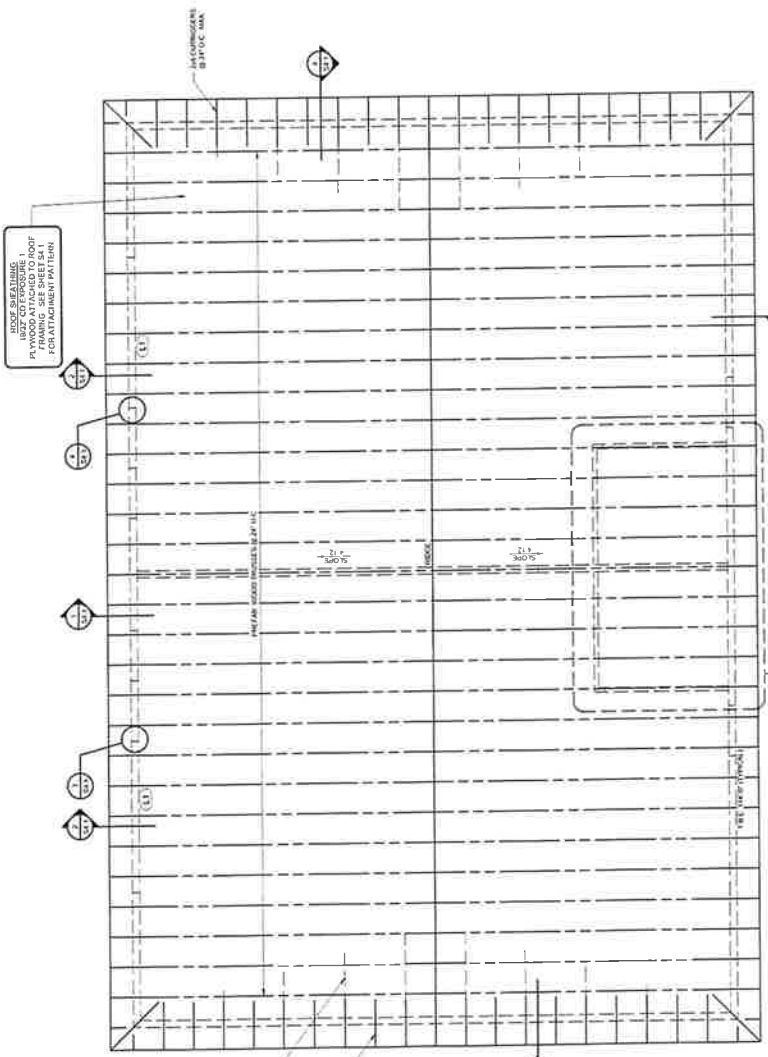

NOTES:
1 SEE SHEET S1.0 FOR GENERAL NOTES & SCHEDULES.
2 UNLESS NOTED OTHERWISE, UNLESS OTHERWISE SPECIFIED, ALL DIMENSIONS ARE IN FEET AND INCHES.
3 ALL DIMENSIONS SHALL BE TO FACE UNLESS OTHERWISE SPECIFIED.
4 ALL DIMENSIONS SHALL BE TO CENTER UNLESS OTHERWISE SPECIFIED.
5 ALL DIMENSIONS SHALL BE TO CENTER UNLESS OTHERWISE SPECIFIED.
6 TRUSS SUPPORT SHALL BE TO CENTER UNLESS OTHERWISE SPECIFIED.
7 UNLESS OTHERWISE SPECIFIED, ALL DIMENSIONS SHALL BE TO CENTER UNLESS OTHERWISE SPECIFIED.

ROOF FRAMING PLAN
SCALE: 1/4"=1'-0"



PARTIAL PLAN - CEILING FRAMING PLAN
SCALE: 1/4"=1'-0"



K&S Engineering, PLLC
Professional Engineer
1402.1
7.18.2025

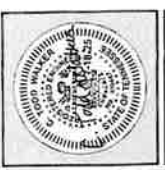

LYLE COOK-MARTIN
ARCHITECTS
310 Franklin Street / Clarksville, TN 37040
TEL: 931.552.4771 / email: bnmartin@lylecookmartin.com

EAST HICKMAN HIGH SCHOOL
AGRICULTURAL/VOCATIONAL
EDUCATION BUILDING
LYLES, TENNESSEE
FOUNDATION DETAILS

Sheet No.	1402.1
Date	7.18.2025
Drawn By	BKS
Checked By	
Design Date	

S3.1
SHEET NO.

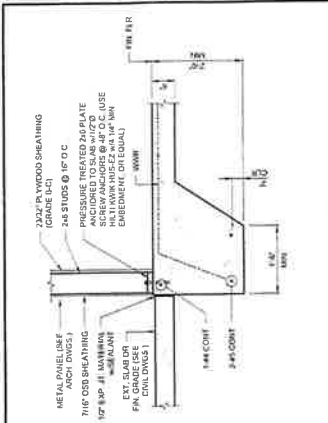

1 **DETAIL**
TURNDOWN SLAB
SCALE: 3/4\"/>

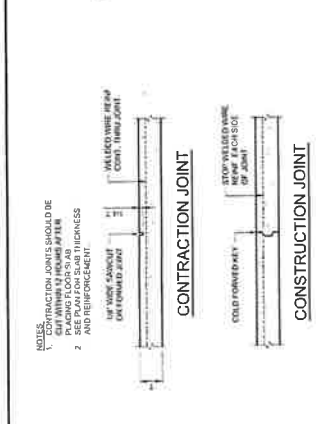

TYP. **DETAIL**
SLAB JOINTS
SCALE: 3/4\"/>

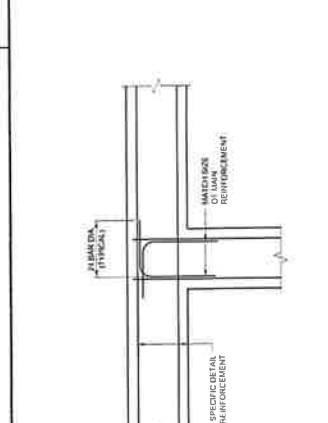

TYP. **DETAIL**
FOOTING JUNCTION REINFORCEMENT
SCALE: 3/4\"/>

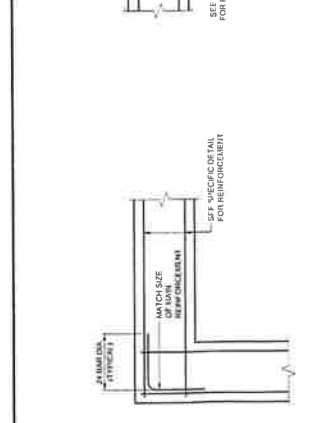

TYP. **DETAIL**
FOOTING CORNER REINFORCEMENT
SCALE: 3/4\"/>

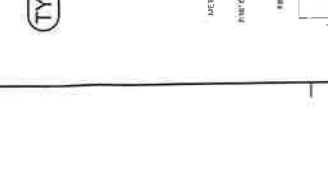

2 **DETAIL**
TURNDOWN SLAB
SCALE: 3/4\"/>

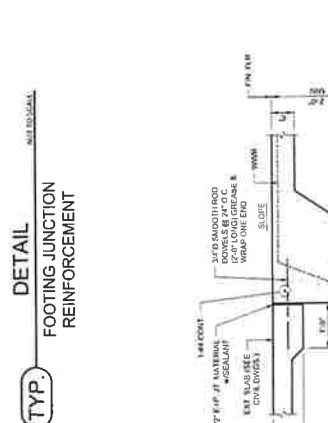

3 **DETAIL**
TURNDOWN SLAB AT OPENING
SCALE: 3/4\"/>

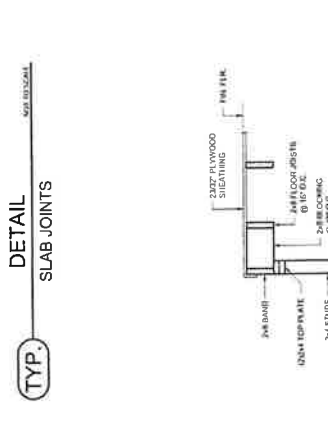

4 **DETAIL**
JOISTS PARALLEL TO STUD WALL
SCALE: 3/4\"/>

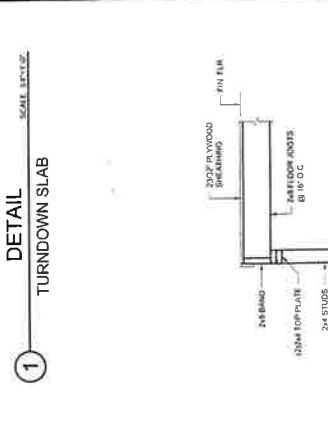

5 **DETAIL**
JOISTS BEARING AT STUD WALL
SCALE: 3/4\"/>

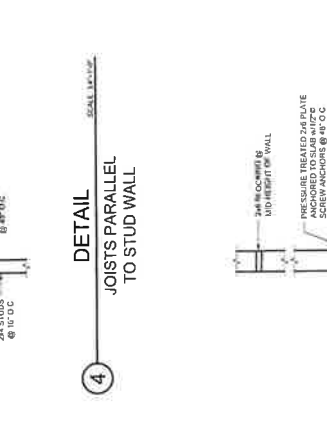

6 **DETAIL**
JOISTS BEARING AT INTERIOR WALL
SCALE: 3/4\"/>

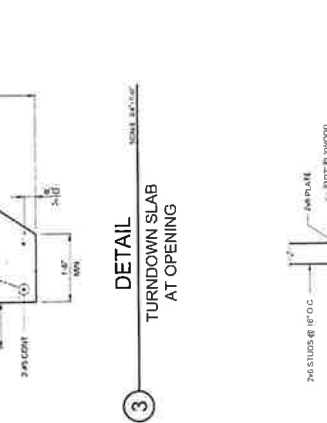

7 **DETAIL**
JOISTS BEARING AT EXTERIOR WALL
SCALE: 3/4\"/>

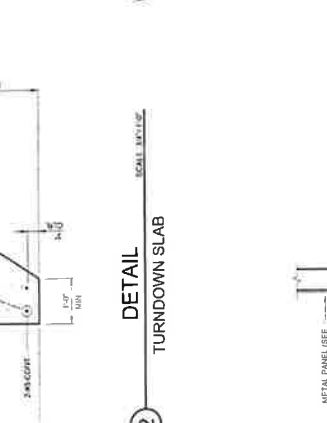

8 **DETAIL**
THICKENED SLAB AT 2x6 STUD WALL
SCALE: 3/4\"/>

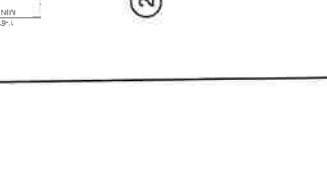

9 **DETAIL**
THICKENED SLAB @ 2x4 STUD WALL
SCALE: 3/4\"/>

K&S
Engineering, PLLC
Structural Engineers
1000 N. 10th St., Suite 100
Clarksville, TN 37040
Phone: 931.552.4771
Fax: 931.552.4772
www.kandse.com



LYLE·COOK·MARTIN
ARCHITECTS
 310 Franklin Street / Clarksville, TN 37040
 TEL: 931.652.4771 / email: bmartin@lylecookmartin.com

EAST HICKMAN HIGH SCHOOL
AGRICULTURAL/VOCATIONAL
EDUCATION BUILDING
LYLES, TENNESSEE
FRAMING DETAILS

Project No.	1402.1
Issue Date	7.18.2025
Drawn By	BKS
Checked By	
Revision Description	

S4.1
 SHEET NO.

K&S ENGINEERING, PLLC
 2005-152
 PROFESSIONAL ENGINEER
 STATE OF TENNESSEE
 LICENSE NO. 2005-152

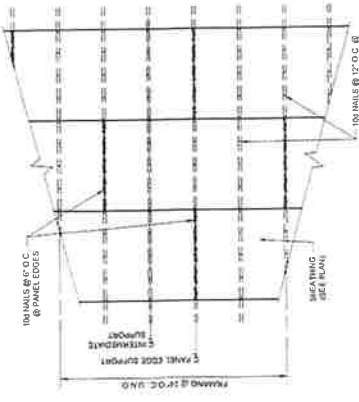

DETAIL TYP.
ROOF/CEILING SHEATHING ATTACHMENT
 SCALE: 1/4"=1'-0"

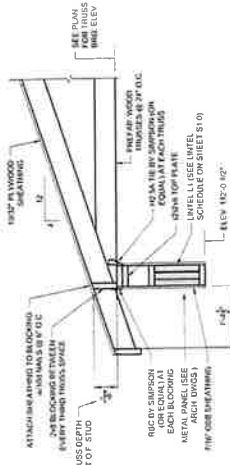

DETAIL 2
TRUSS BEARING AT LINTEL L1
 SCALE: 3/4"=1'-0"

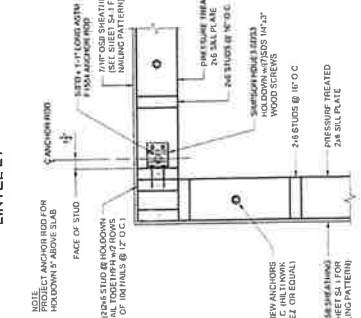

DETAIL 5
HOLDDOWN @ CORNER
 SCALE: 1/2"=1'-0"

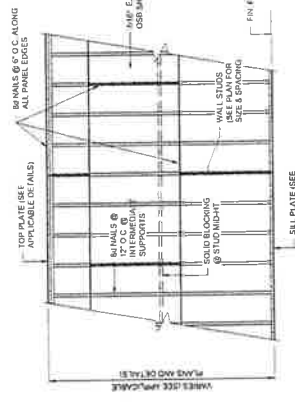

DETAIL TYP.
WALL SHEATHING ATTACHMENT PATTERN
 SCALE: 1/4"=1'-0"

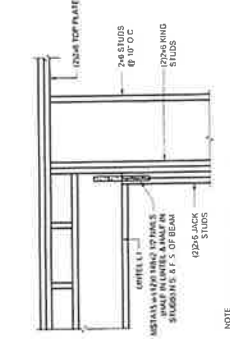

DETAIL 3
LINTEL BEARING AT JAMB STUDS
 SCALE: 3/4"=1'-0"

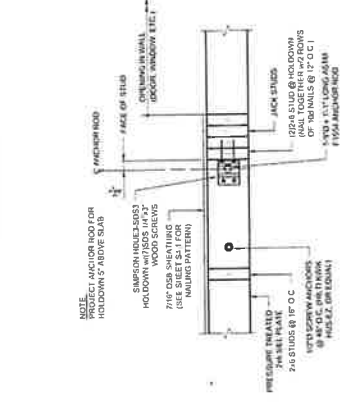

DETAIL 6
HOLDDOWN @ EDGE OF OPENING
 SCALE: 1/2"=1'-0"

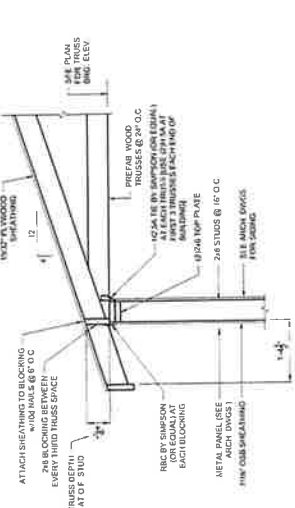

DETAIL 1
TRUSS BEARING AT STUD WALL
 SCALE: 1/2"=1'-0"

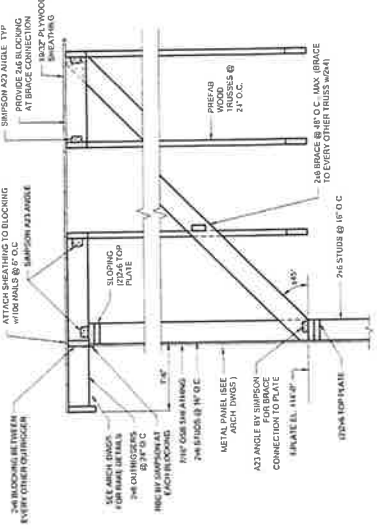

DETAIL 4
GABLE END WALL FRAMING
 SCALE: 1/2"=1'-0"



ENTECH ENGINEERING
 MECHANICAL ENGINEERING
 1000 W. UNIVERSITY BLVD.
 SUITE 100
 MEMPHIS, TN 38117
 (901) 522-4771
 www.entecheng.com



LYLE COOK-MARTIN ARCHITECTS
 310 Franklin Street / Clarksville, TN 37040
 TEL: 931.552.4771 / email: bmartin@lylecookmartin.com

**EAST HICKMAN HIGH SCHOOL
 EDUCATIONAL BUILDING
 LYLES, TENNESSEE**
 H.V.A.C.
 FLOOR PLAN

Project No.	1402.1
Issue Date	07/18/2025
Design By	EEL
Drawn By	
Checked By	
Revision Date	
Revision Description	

M2.1
 SHEET 03

GENERAL HVAC NOTES:

- THE IMPACT OF THE SPECIFICATION AND THE CONTRACT IS TO PROVIDE A COMPLETE AND ACCURATE MECHANICAL SYSTEM DESIGN AND INSTALL ALL LABOR, MATERIAL AND INSTALL ALL EQUIPMENT AND MATERIALS NECESSARY TO COMPLETE THE WORK.
- COORDINATE DUCTWORK WITH ALL TRADES AND FIELD CONDITIONS PRIOR TO FABRICATION. SUBMIT ANY MAJOR CHANGES IN DUCT ROUTING OR DUCT SIZING AS A SHOP DRAWING TO THE ARCHITECT/ENGINEER FOR REVIEW.
- COORDINATE ALL DUCTWORK WITH ALL CEILING, WALL, AND FLOOR FINISHES. DO NOT LOCATE AIR INLETS WITHIN 3 FEET OF CEILING SINKS OR RECEPTS.
- MAINTAIN CLEARANCES FROM ELECTRICAL PANELS AS REQUIRED BY N.E.C.
- MAINTAIN CLEARANCES FOR SERVICE OF HVAC EQUIPMENT AS PROVIDED BY MANUFACTURER. PROVIDE MECHANICAL ROOM SHOP DRAWINGS AS REQUIRED FOR COORDINATION.
- REFERENCE CONTROL SCHEMATICS & DUCTWORK DETAILS FOR MANUAL AND AUTOMATIC DAMPER LOCATIONS.
- REFERENCE ARCHITECTURAL ELEVATIONS FOR LOCATIONS OF LOUVERS AND WALL CAPS.
- TESTING ADJUSTING & BALANCING OF AIR SHALL INITIALLY BE ACCOMPLISHED UNDER UNOCCUPIED CONDITIONS AS INDICATED ON THE DRAWINGS AND THEN THE INSIDE AIR BALANCED AFTER RETURN AIR INLETS REBALANCED PROPORTIONALLY LOWER TO ACCOUNT FOR DIFFERENCE.
- DUCTWORK LOCATED IN ROOMS WITH HIGH HUMIDITY CONDITIONS SHALL HAVE:
 - FOR PAINTING: GRILLES SHALL BE SPRAY DUCT MOUNTED GRILLE WITH DOUBLE COATING OF EPOXY RESIN AND AN ANTI-CORROSION COATING.
 - FOR SILENCING: SHALL BE 2" DOUBLE WALL TO 1" INS. STAINLESS STEEL EXTRACTOR, LOW PROFILE BLADES. MAX. VE. 45

WALL AIR INLETS:

- SUPPLY DUCT TURNED UP WALL AND INTO BUILDING HIGH AND BELOW STRUCTURE - FIELD VERIFY BEST ROUTING. SEE DETAIL FOR EXTERIOR DUCT PROTECTION DETAIL.

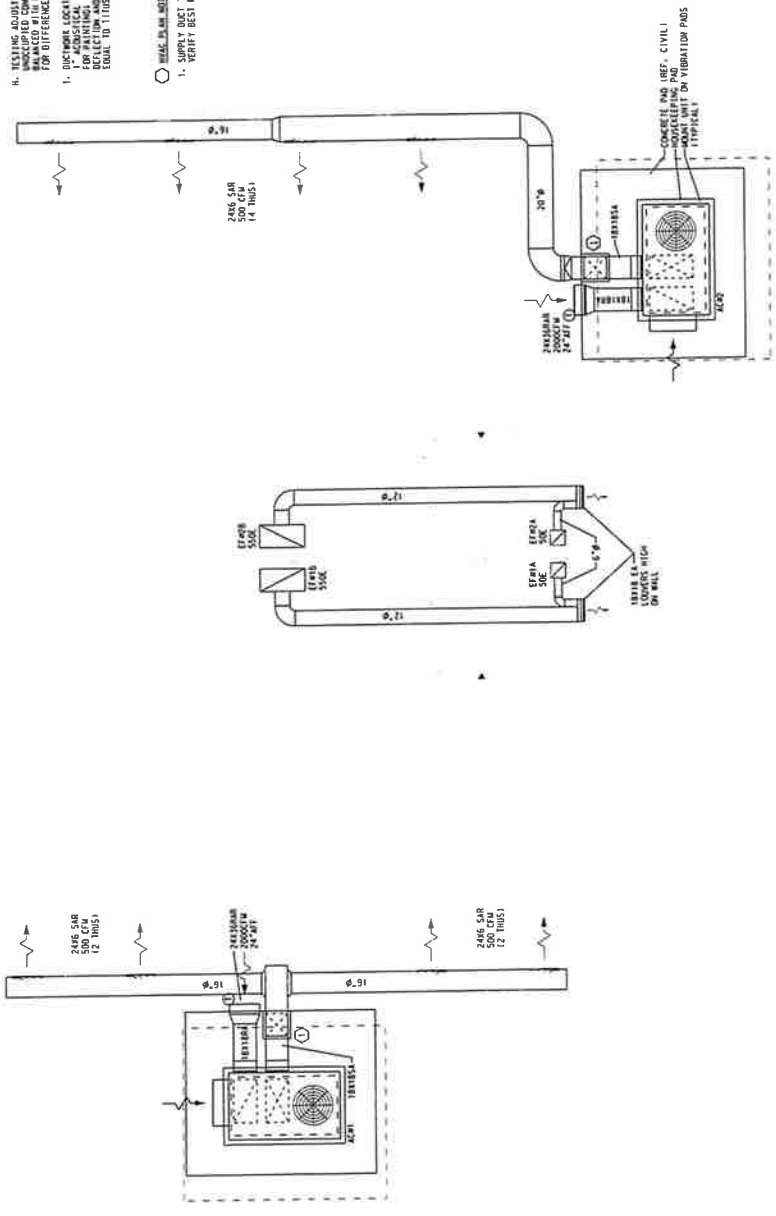

H.V.A.C. FLOOR PLAN
 SCALE: 1/4" = 1'-0"

Project No.	1402.1
Issue Date	07/18/2025
Client	E.E.L.
Revision	09.05.2025

**EAST HICKMAN HIGH SCHOOL
AGRICULTURAL/VOCATIONAL
EDUCATION BUILDING
LYLES, TENNESSEE**
ELECTRICAL
FLOOR PLAN

L.T.L. COOK-MARTIN
ARCHITECTS
310 Franklin Street / Clarksville, TN 37040
TEL: 931.552.4771 / email: bmartin@lylcookmartin.com

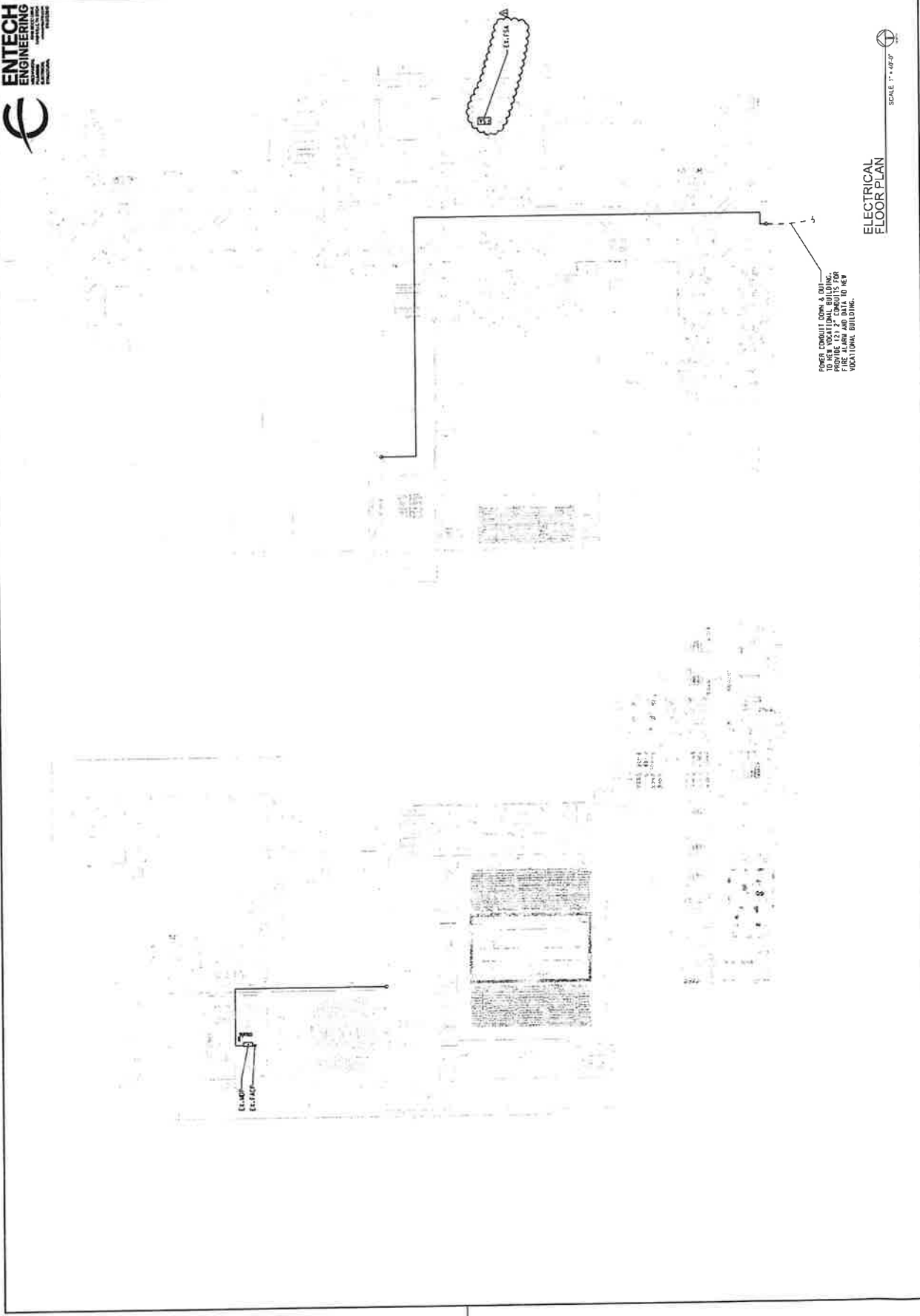

ELECTRICAL FLOOR PLAN
SCALE: 1" = 48'-0"

Project No.	1402.1
Issue Date	07/18/2025
Open By	E.E.L.
Revision Date	
Revision Description	

**EAST HICKMAN HIGH SCHOOL
AGRICULTURAL BUILDING
LYLES, TENNESSEE**

**LYLE-COOK-MARTIN
ARCHITECTS**

310 Franklin Street / Clarksville, TN 37040
TEL: 931.552.4771 / email: bmartin@lylecookmartin.com

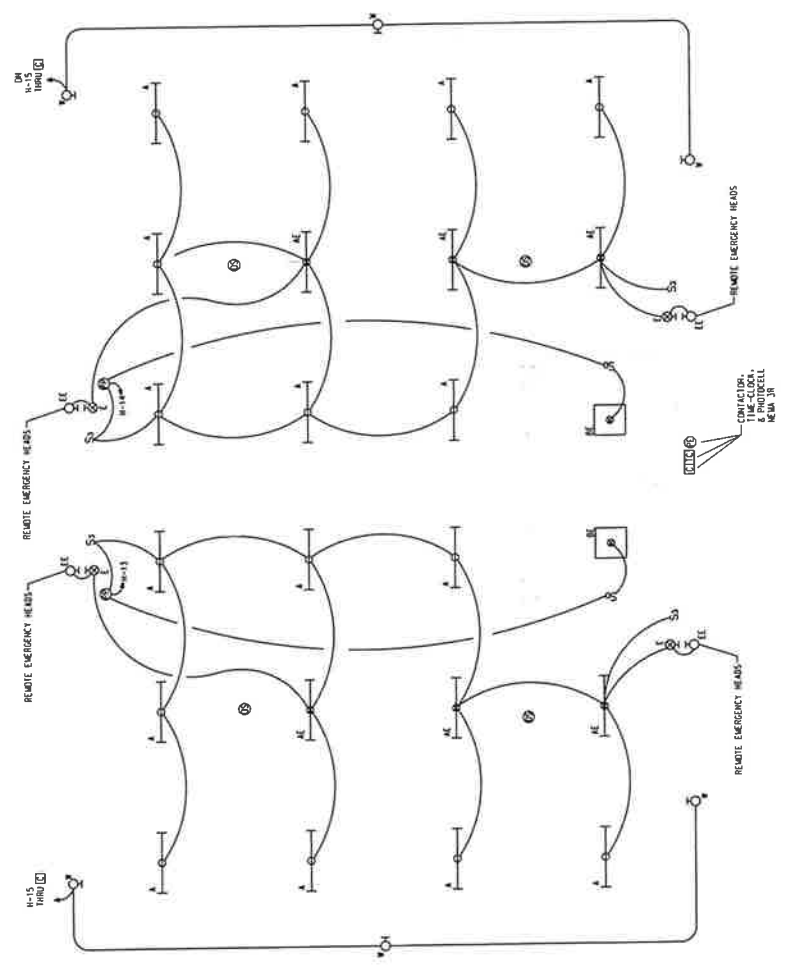

- GENERAL NOTES:**
- ALL EXIT AND EMERGENCY BATTERIES TO BE CONNECTED TO AN UNSWITCHED LEG OF THE LIGHTING CIRCUIT.
 - COORDINATE ALL MOUNTING HEIGHTS WITH ARCHITECTURAL ELEVATIONS.
 - ALL EXTERIOR LIGHTS ROUTED THROUGH THE LIGHTING CONTACTOR TO BE CONTROLLED WITH THE PHOTOCELL INITIATED TIMECLOCK. ALL PHOTOCELL TO THE NORTH EAST.

LIGHTING FLOOR PLAN

SCALE: 1/4" = 1'-0"

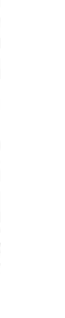
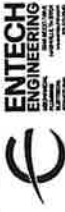

LIGHTING FIXTURE SCHEDULE

TYPE	MANUFACTURER	CATALOG NUMBER	VOL. I LOT. TYPE	LUMPS	TYPE	REMARKS
A	COLUMBIA	MS74-40L-CF-4E0	120V / 277	31.6W LED	SURFACE	4" LINEAR STRIP
AE	COLUMBIA	MS74-40L-CF-4E0-E11.14	120V / 277	31.6W LED	SURFACE	4" LINEAR STRIP W/ EM BATTERY
BE	COLUMBIA	LC122-5-40L-640H-4E0-E11.14	120V / 277	25.7W LED	SURFACE	2x2 W/ IN BATTERY
F	EKO	PR1-C-15-4L	120V / 277	35W LED	SURFACE	WALL PACK
E	COMPASS	CE046	120V / 277	---	UNV	E111 SIGN
EE	COMPASS	CE040	120V / 277	---	UNV	REMOTE HEADS

BRANCH CIRCUITING LEGEND

→	A-1/3	ONE 1-POLE OUT HOOKUP TO PANEL A
→→	A-1/3	TWO 1-POLE OUT HOOKUPS TO PANEL A
→→→	A-1/3.5	THREE 1-POLE OUT HOOKUPS TO PANEL A
→→→→	A-1/3	ONE 2-POLE OUT HOOKUP TO PANEL A
→→→→→	A-1/3.2/4	TWO 2-POLE OUT HOOKUPS TO PANEL A
→→→→→→	A-1/3/5	ONE 3-POLE OUT HOOKUP TO PANEL A

NOTE: ALL MULTI-WIRE BRANCH CIRCUITS TO COMPLY WITH 2017 NEC 210.4

GENERAL ELECTRICAL LEGEND

SYMBOL	DESCRIPTION	UIC. REF.
○	CEILING OUTLET, SURFACE FIXTURE	48" AFF
○	CEILING OUTLET, SURFACE FIXTURE W/BATTERY BACK UP	48" AFF
○	CEILING OUTLET, RECESSED FIXTURE	48" AFF
○	CEILING OUTLET, RECESSED FIXTURE W/BATTERY BACK UP	48" AFF
○	BRACKET OUTLET	48" AFF
□	SURFACE FLUORESCENT LIGHTING FIXTURE	18" AFF
□	RECESSED FLUORESCENT LIGHTING FIXTURE	18" AFF
□	FLUORESCENT STRIP LIGHT FIXTURE	18" AFF
□	EXIT LIGHT, WARRMS AS SHOWN, ON LIFE SAFETY CIRCUIT	18" AFF
□	EMERGENCY LIGHT WALL MOUNTED AT 7'-6" AFF, UDN	18" AFF
S	SINGLE POLE SWITCH	ABC
S3	THREE-WAY SWITCH	ABC
S4	FOUR-WAY SWITCH	ABC
S5	DUAL TECHNOLOGY OCCUPANCY SENSOR SWITCH	ABC
⊕	DUPLEX GROUNDING RECEPTACLE	ABC
⊕	DUPLEX GROUNDING RECEPTACLE	ABC
⊕	FLOOR RECEPTACLE	ABC
⊕	DOUBLE DUPLEX GROUNDING RECEPTACLE	ABC
⊕	DOUBLE DUPLEX GROUNDING RECEPTACLE	ABC
⊕	JUNCTION OR PULL BOX	ABC
⊕	MOTOR, E.G. FAN, EXHAUST FAN	ABC
S4	MINIMAL MOTOR STARTER OR RELAY CONTROL	ABC
⊕	MAGNETIC MOTOR STARTER OR TERMINAL CONNECTION	ABC
⊕	SAFETY SWITCH, WP INDICATES WARM JR. FUSED, U.O.N.	ABC
⊕	LIGHTING OR POWER PANEL	ABC
⊕	MIN OR SUB-DISTRIBUTION PANEL	ABC
⊕	TIME CLOCK - SEE SPECS	ABC
⊕	CONTRACTOR - SEE SPECS	ABC
⊕	PHOTO-ELECTRIC SWITCH - A.M. WORK/NO-AST, SEE SPECS	ABC
⊕	THERMOSTAT, SEE MECHANICAL	ABC
⊕	CONDUIT, CONCEALED IN CEILING OR WALL	ABC
⊕	CONDUIT, CONCEALED IN SLAB OR BELOW FLOOR/GRADE	ABC
⊕	CONDUIT, EXPOSED	ABC
⊕	CONDUIT, TURNING UP	ABC
⊕	CONDUIT, TURNING DOWN	ABC
⊕	CONDUIT, ELECTRICAL PRIMARY	ABC
⊕	CONDUIT, ELECTRICAL SECONDARY	ABC
⊕	WEATHERPROOF	ABC
⊕	GROUND FAULT CURRENT INTERRUPTER	ABC
⊕	ABOVE FINISHED FLOOR	ABC
⊕	ABOVE COMPUTER	ABC
⊕	UNDER FLOOR	ABC
⊕	UNLESS OTHERWISE NOTED	ABC
⊕	GENERAL CONTRACTOR	ABC
⊕	MECHANICAL CONTRACTOR	ABC
⊕	ELECTRICAL CONTRACTOR	ABC
⊕	PLUMBING CONTRACTOR	ABC
⊕	ELECTRIC DRINKING FOUNTAIN	ABC
⊕	WATER HEATER	ABC
⊕	ROOF TOP UNIT	ABC
⊕	TELEPHONE TERMINAL BOARD	ABC
⊕	MULTI USE OUTLET FOR VOICE, DATA, VIDEO 11°C, TO ABOVE CEILING	ABC
⊕	CEILING MOUNTED, DUAL TECHNOLOGY OCCUPANCY SENSOR	ABC
⊕	POWER PACK	ABC
⊕	AREA OR STREET LIGHTING FIXTURE	ABC

LYLE COOK-MARTIN ARCHITECTS

310 Franklin Street / Clarksville, TN 37040
TEL: 931.552.4771 / email: lmartin@lylecookmartin.com

EAST HICKMAN HIGH SCHOOL
AGRICULTURAL/VOCATIONAL
EDUCATION BUILDING
LYLES, TENNESSEE
ELECTRICAL
LEGENDS AND SCHEDULES

Project No: 1402.1
Issue Date: 07/18/2025
Drawing No: E.E.1
Revision Date: 09.05.2025
Revision Title:

E5.1

Invitation to Bid

The Hickman County Finance Office is accepting sealed bids for the building of a new vocational shop building for CTE classes at East Hickman High School.

Bid documents with specifications are online at www.hickmank12.org/request-for-proposal. All bidders will be required to submit a conflict-of-interest disclosure form that can be obtained at www.hickmank12.org/request-for-proposal. Upon retrieval of documents, please email your intent to bid to the Architect's office; Ellen Scruggs escruggs@lylecookmartin.com to be placed on a list of bidders. Check with Architect to determine Addenda that may have been issued prior to bid date.

Sealed bids must be mailed or delivered to the Hickman County Finance Office, 114 North Central Avenue, Suite 203, Centerville, TN 37033 and clearly marked on the outside of the envelope "Agricultural/Vocational Building at EHHS" by October 16, 2025, 10 AM. Bids will be opened on October 16, 2025, 10:05 AM at HC Board of Education offices located at 115 Murphree Ave., Centerville, TN 37033.

Then Hickman County Board of Education reserves the right to accept or reject any and all bids or parts of bids and to waive any informalities that would prevent the acceptance of a better bid.



Misty Shelton

VPK Supervisor/Licensure Coordinator/Board Policies

Hickman County Schools
115 Murphree Avenue
Centerville, Tennessee 37033

To: School Board Members

From: Misty Shelton

Date: October 2025

1st Reading:

4.606- Graduation Activities- Dr. Dunlap requested the change from developed to approved on line 28. He is requesting that the 2nd reading be waived and approved on the 1st reading.

Up for Review:

- 6.504 Migrant Students
- 6.505 Students in Foster Care
- 6.506 Students from Military Families
- 6.600 Student Records
- 6.601 Annual Notification of Rights
- 6.6011 Rights and Responsibilities of Students of Legal Age
- 6.602 Inspection and Correction Procedures
- 6.6031 Directory Information Procedure
- 6.604 Media Access to Students
- 6.704 Student Publications
- 6.709 Student Fees and Fines

Thank you for your careful consideration of these policies.

931-729-3391 ext. 2226

misty.shelton@hickmank12.org

fax 931-729-3834

Hickman County Board of Education

Descriptor Term: Graduation Activities	Descriptor Code: 4.606	Issued Date: 09/09/24
	Rescinds: 4.606	Issued: 07/11/22

1 Students who have met all graduation requirements on the day of graduation and students who are within
2 two (2) or fewer credits of meeting all requirements¹ and can complete the requirements during the
3 summer may participate in graduation activities. If extenuating circumstances exist at any school, the
4 matter shall be presented to the Board prior to graduation activities.

5 Students are expected to participate in all graduation activities, and graduation apparel shall be
6 determined by the administration of each school and shall be the personal expense of each student. Any
7 fees required for graduation ceremonies shall be waived for students who are eligible to receive free or
8 reduced price lunches, and in such cases, the school shall assume responsibility for payment of fees.²

9 Graduation ceremonies shall be physically accessible to all students, their parents and/or guardians, and
10 other interested citizens.³

11 Students who do not wish to participate in graduation activities shall notify the school principal in writing
12 at least five (5) days prior to the day of graduation. Non-participating students shall receive their
13 diplomas or certificates from the principal's office within one (1) week of the day of graduation.

14 Graduation activities organized by district employees shall not be religious in nature.⁴ The content of
15 any students' speeches shall not reflect the endorsement, sponsorship, position, or expression of the
16 school, employees, or Board.

17 The director of schools shall develop procedures to ensure that students are recognized at graduation
18 ceremonies for the following achievements:⁵

- 19 • Honors;
- 20 • State Honors;
- 21 • State Distinction;
- 22 • District Distinction;
- 23 • Tri-Star Scholar;
- 24 • Students receiving a TN Seal of Biliteracy;
- 25 • Students voluntarily completing at least ten (10) hours of community service each semester the
26 student is in attendance at a public high school;
- 27 • Students receiving a gold or platinum medal on National Career Readiness Certificate; and
- 28 • Students graduating with a district-developed approved work ethic distinction.

Legal References

1. [TCA 49-6-405\(b\)\(2\)](#)
2. [TCA 49-2-114](#)
3. [28 CFR § 36.201](#)
4. [Lee v. Weisman, 505 U.S. 577\(1992\), 112 S. Ct. 2649, 120 L. Ed. 2d 467 \(1992\)](#)
5. [State Board of Education Policy 2.103; TCA 49-6-6010](#)

Cross References

Section 504 & ADA Grievance Procedures 1.802
Student Fees and Fines 6.709

Hickman County School System

Graduation Activities

4.606AP

Graduation Activities

Formal graduation activities are reserved for graduation from high school.

Qualification for and participation in graduation activities or commencement ceremonies shall be limited to seniors that are considered in good standing by the school of record for attendance.

To participate in graduation activities, all students shall comply with the dress code set forth in board policy and the student handbook.



Misty Shelton

VPK Supervisor/Licensure Coordinator/Board Policies

Hickman County Schools

115 Murphree Avenue

Centerville, Tennessee 37033

To: School Board Members

From: Misty Shelton

Date: October 2025

1st Reading:

4.606- Graduation Activities- Dr. Dunlap requested the change from developed to approved on line 28. He is requesting that the 2nd reading be waived and approved on the 1st reading.

Up for Review:

- 6.504 Migrant Students
- 6.505 Students in Foster Care
- 6.506 Students from Military Families
- 6.600 Student Records
- 6.601 Annual Notification of Rights
- 6.6011 Rights and Responsibilities of Students of Legal Age
- 6.602 Inspection and Correction Procedures
- 6.6031 Directory Information Procedure
- 6.604 Media Access to Students
- 6.704 Student Publications
- 6.709 Student Fees and Fines

Thank you for your careful consideration of these policies.

931-729-3391 ext. 2226

misty.shelton@hickmank12.org

fax 931-729-3834

Hickman County Board of Education

	Descriptor Term: Migrant Students	Descriptor Code: 6.504	Issued Date: 07/10/23
		Rescinds: 6.504	Issued: 05/03/21

1 The Board directs the administration to identify migratory students in the district, as required by law,
2 and to develop written administrative procedures for ensuring that migrant students receive services for
3 which they are eligible. In developing and implementing a program to address the needs of migratory
4 students the district will:¹

- 5 1. Identify migratory students and assess the educational and related health and social needs of each
6 student.
- 7 2. Provide a full range of services to migrant students including applicable Title I programs, special
8 education, gifted education, vocational education, language programs, counseling programs,
9 elective classes, fine arts classes, etc.
- 10 3. Provide migratory children with the opportunity to meet the same statewide assessment standards
11 that all students are expected to meet.
- 12 4. To the extent feasible, provide advocacy and outreach programs to migratory students and their
13 families and professional development for district staff.
- 14 5. Provide parents an opportunity for meaningful participation in the program.

15 If a migrant student is identified by the district, the director of schools or designee will notify the
16 Tennessee Department of Education and request assistance if needed.
17
18

Legal References

1. 20 USCA §§ 6318, 6391, 6399

Cross References

School Admissions 6.203
Homeless Students 6.503

Hickman County Board of Education

Descriptor Term: Students in Foster Care	Descriptor Code: 6.505	Issued Date: 07/10/23
	Rescinds: 6.505	Issued: 05/03/21

1 The Hickman County School System shall provide all students in foster care, to include those awaiting
2 foster care placement, with a free and appropriate public education.

3 ENROLLMENT

4 Students in foster care, to include those awaiting foster care placement, shall be immediately enrolled,
5 even if the student is unable to produce records normally required for enrollment (i.e. academic records,
6 immunization records, health records, proof of residency), or missed the district's application or
7 enrollment deadlines.¹

8 PLACEMENT

9 The district and the child welfare agency shall determine whether placement in a particular school is in
10 a student's best interest. Other parties, including the student, foster parents, and biological parents (if
11 appropriate), shall be consulted. If the child has an IEP or a Section 504 plan, then the relevant school
12 staff members shall participate in the best interest decision process. This determination shall be made as
13 quickly as possible to prevent educational disruption.

14 Placement shall be determined based on the student's best interest. At all times, a strong presumption
15 that keeping the student in the school of origin is in the student's best interest shall be maintained.² For
16 the purposes of this policy, school of origin shall mean the school in which the student was enrolled,
17 including a preschool/pre-k program, at the time of placement in foster care or at the time of a placement
18 change if the student is already placed in foster care.³

19 When determining placement, student-centered factors including, but not limited to, the following shall
20 be considered:

- 21 1. Preferences of the student;
- 22 2. Preferences of the student's parent(s) or education decision maker(s);
- 23 3. The student's attachment to the school, including meaningful relationships with staff and peers;
- 24 4. Placement of the student's siblings;
- 25 5. Influence of the school climate on the student, including safety;
- 26 6. The availability and quality of the services in the school to meet the student's educational needs;
- 27 7. History of school transfers and how they have impacted the student;
- 28 8. How the length of the commute would impact the student;
- 29 9. Whether the student is receiving special education and related services, and if so, the availability
30 of those required services in a school other than the school of origin; and
- 31 10. Whether the student is an EL and is receiving language services, and, if so, the availability of
32 those required services in a school other than the school of origin.

1 Transportation costs should not be considered when determining a student's best interest.

2 If it is not in the student's best interest to attend the school of origin, the director or his/her designee shall
3 provide a written explanation of the reasons for the determination. The written explanation shall include
4 a statement regarding the right to appeal the placement decision. If the placement decision is appealed,
5 the district shall refer the student to the district coordinator for children in foster care, who shall carry
6 out the dispute resolution process as expeditiously as possible and in accordance with the law.² Until the
7 dispute is resolved, to the extent feasible, the student shall remain in his/her school of origin.²

8 **TRANSPORTATION**^{3,4}

9 The district shall collaborate with the local child welfare agency to develop and implement clear and
10 written procedures governing how transportation to a student's school or origin shall be provided,
11 arranged, and funded. This transportation will be provided for the duration of the student's time in
12 foster care.

13 The director of schools shall develop administrative procedures to provide for transportation of
14 students in foster care.⁵ These procedures must ensure that:

- 15 1. Students in foster care needing transportation to their schools of origin will promptly receive
16 that transportation in a cost-effective manner and in accordance with federal law; and
- 17 2. If there are additional costs incurred in providing transportation to the school of origin, the
18 district will provide such transportation if:
 - 19 a. the local child welfare agency agrees to reimburse the district for the cost of such
20 transportation;
 - 21 b. the district agrees to pay for the cost; or
 - 22 c. the district and local child welfare agency agree to share the cost.⁴

23 The district will ensure that a student in foster care, to include a student awaiting foster care placement,
24 remains in his/her school of origin while any disputes regarding transportation costs are being
25 resolved.

1. Elementary and Secondary Education Act (ESEA), as amended by ESSA (Pub. L. 114-95) § 1111(g)(1)(E)(ii)-(iii) Attendance 6.200
School Admissions 6.203
2. Elementary and Secondary Education Act (ESEA), as amended by ESSA (Pub. L. 114-95), § 1111 (g)(1)(E)(i)-(iv)
3. Elementary and Secondary Education Act (ESEA), as amended by ESSA (Pub. L. 114-95), § 1111 (g)(1)(E)
4. Elementary and Secondary Education Act (ESEA), as amended by ESSA (Pub. L. 114-95), § 1112 (c)(5); § 475(4)(A) of the Social Security Act, 42 U.S.C. § 675(4)(A)
5. Elementary and Secondary Education Act (ESEA), as amended by ESSA (Pub. L. 114-95), § 1112 (c)(5)(B)(i)

Hickman County Board of Education

	Descriptor Term: Students from Military Families	Descriptor Code: 6.506	Issued Date: 07/10/23
		Rescinds: 6.503	Issued: 05/03/21

1 *General*

2 The Director of Schools shall develop the necessary administrative procedures to ensure that students
3 with parent(s)/guardian(s) in the armed services are identified and that appropriate and available
4 services are provided for these students.¹

5 **RELOCATION OF MILITARY SERVICE MEMBER²**

6 A student who does not currently reside within the school district shall be allowed to enroll if he/she is
7 a dependent child of a service member who is being relocated to Tennessee on military orders. To be
8 eligible for enrollment, the student will need to provide documentation that he/she will be a resident of
9 the school district on relocation.

10 Within fifteen (15) days of enrollment, the parent(s)/guardian(s) of the student shall provide proof of
11 residency within the school district.

12 **ABSENCES**

13 Principals shall provide students with a one (1) day excused absence prior to the deployment of and a
14 one (1) day excused absence upon the return of a parent/guardian serving active military service.

15 Principals shall also allow up to ten (10) excused cumulative absences per year for students to visit a
16 parent/guardian during a deployment cycle. The student shall provide documentation to the school as
17 proof of his/her parent's/guardian's deployment. Students shall be permitted to make up school work
18 missed during these absences.³

Legal References

1. State Board of Education Policy 2.103
2. TCA 49-6-3101
3. TCA 49-6-3019

Cross References

- Attendance 6.200
School Admissions 6.203
Attendance of Non-Resident Students 6.506

Hickman County Board of Education

Descriptor Term: Student Records	Descriptor Code: 6.600	Issued Date: 07/07/25
	Rescinds: 6.600	Issued: 08/07/23

1 A cumulative record shall be kept for each student enrolled in school. The folder shall contain a health
2 record, attendance record, and scholarship record; shall be kept current; and shall accompany the student
3 through his/her school career.¹

4 The name used on the record of the student entering the school system must be the same as that shown
5 on the birth certificate, unless evidence is presented that such name has been legally changed. If the
6 parent does not have, or cannot obtain a birth certificate, then the name used on the records of such
7 student shall be as shown on documents which are acceptable as proof of date of birth.

8 The name used on the records of a student entering the system from another school must be the same as
9 that shown on records from the school previously attended unless evidence is presented that such name
10 has been legally changed as prescribed by law.

11 When a student transfers to another school within the school district or to a school outside of the school
12 district, copies of the student's records, including the student's disciplinary records, shall be sent to the
13 transfer school within five (5) business days of the date on which the student's records request was
14 received by the school.²

15 All records shall be remitted in accordance with the Family Education Rights and Privacy Act (FERPA).³

16 ACCESS TO STUDENT RECORDS

17 Student records shall be confidential. Authorized school officials shall have access to and permit access
18 to student education records for legitimate educational purposes.⁴ A "legitimate educational interest" is
19 the official's need to know information in order to:

- 20 1. Perform required administrative tasks;
- 21 2. Perform a supervisory or instructional task directly related to the student's education;
- 22 3. Perform a service or benefit for the student or the student's family such as health care, counseling,
23 student job placement, or student financial aid.

24 Authorized school officials may release information from or permit access to a student's education record
25 without the parent(s) or eligible student's* prior written consent in the following instances:

- 26 1. To comply with a judicial order or lawfully issued subpoena. The school system will make a
27 reasonable effort to notify the student's parent(s) or the eligible student before making a
28 disclosure;⁵
29

- 1 2. If the disclosure is an item of directory information;⁶
- 2
- 3 3. To comply with the requirements of child abuse reports to the extent known by the school
- 4 officials including the name, address, and age of the child; the name and address of the person
- 5 responsible for the care of the child, and the facts requiring the report;⁷
- 6
- 7 4. When certain federal and state officials need information in order to audit or enforce legal
- 8 conditions related to federally-supported education programs in the school system;⁸
- 9
- 10 5. When the school system has entered into a contract or written agreement for an organization to
- 11 conduct scientific research on the system's behalf to develop tests or improve instruction,
- 12 provided that the studies are conducted in a manner which will not permit the personal
- 13 identification of students and their parents by individuals other than representatives of the
- 14 organization and the information will be destroyed when no longer needed for the purpose for
- 15 which the study was conducted;⁹
- 16
- 17 6. To appropriate officials if the parent(s) claim the student as a dependent as defined by the
- 18 Internal Revenue Code;¹⁰
- 19
- 20 7. To accrediting organizations to carry out their accrediting functions;¹¹
- 21
- 22 8. When a student seeks or intends to enroll in another school district or a post-secondary school.
- 23 Parent(s) of students or eligible students have a right to obtain copies of records transferred
- 24 under this provision;¹²
- 25
- 26 9. To financial institutions or government agencies that provide or may provide financial aid to a
- 27 student in order to establish eligibility, to determine the amount of financial aid, to establish
- 28 conditions for the receipt of financial aid, and to enforce financial aid agreements;¹³
- 29
- 30 10. To make the needed disclosure in a health or safety emergency when warranted by the serious-
- 31 ness of the threat to the student or other persons, when the information is necessary and needed
- 32 to meet the emergency, when time is an important and limiting factor, and when the persons to
- 33 whom the information is to be disclosed are qualified and in a position to deal with the
- 34 emergency;¹⁴
- 35
- 36 11. To the Attorney General or his designee for official purposes related to the investigation or
- 37 prosecution of an act of domestic or international terrorism. An educational agency that, in
- 38 good faith, produces education records in accordance with an order issued under this Act shall
- 39 not be liable to any person for that production;¹⁵
- 40
- 41 12. To any agency caseworker or other representative of a state or local child welfare agency or
- 42 tribal organization authorized to access the student's educational records when such agencies or
- 43 organizations are legally responsible for the care and protection of the student;¹⁶

44 Authorized school officials may release information from a student's education record if the student's
45 parent(s) or the eligible student gives written consent for the disclosure. The written consent must
46 include:¹⁷

- 1 1. A specification of the records to be released;
- 2
- 3 2. The reasons for the disclosure;
- 4
- 5 3. The person, organization, or class of persons or organizations to whom the disclosure is to be
- 6 made;
- 7
- 8 4. The signature of the parent(s) or eligible student;
- 9
- 10 5. The date of the consent and, if appropriate, a date when the consent is to be terminated. The
- 11 student's parent(s) or the eligible student* may obtain a copy of any records disclosed under
- 12 this provision.

13 The school system will maintain an accurate record of all requests to disclose information from or to
14 permit access to a student's education records. The system will maintain an accurate record of
15 information it discloses and access it permits. The system will maintain this record as long as it maintains
16 the student's education record.¹⁸

17 The record will include at least:¹⁸

- 18 1. The name of the person or agency that makes the request;
- 19
- 20 2. The interest the person or agency has in the information;
- 21
- 22 3. The date the person or agency makes the request; and
- 23
- 24 4. Whether the request is granted and, if it is, the date access is permitted or the disclosure is
- 25 made.

26 * *The student becomes an "eligible student" when he/she reaches age 18 or enrolls in a post-secondary*
27 *school, at which time all of the above rights become the student's right.*

1. [20 USCA § 1232g](#)
 2. [TCA 49-6-3001\(c\)\(1\); Public Acts of 2025, Chapter No. 156](#)
 3. [TCA 49-1-701](#)
 4. [TCA 10-7-504\(a\)\(4\); 20 USCA § 1232g](#)
 5. [20 USCA § 1232g\(b\)\(2\)\(B\)](#)
 6. [20 USCA § 1232g\(b\)\(2\); TCA 10-7-504\(a\)\(4\)\(A\)](#)
 7. [TCA 37-1-403](#)
 8. [20 USCA § 1232g\(b\)\(3\)](#)
 9. [20 USCA § 1232g\(b\)\(1\)\(F\)](#)
 10. [20 USCA § 1232g\(b\)\(1\)\(H\)](#)
 11. [20 USCA § 1232g\(b\)\(1\)\(G\)](#)
 12. [TRR/MS 0520-01-03-.03\(9\)](#)
 13. [20 USCA § 1232g\(b\)\(1\)\(D\)](#)
 14. [20 USCA § 1232g\(b\)\(1\)\(I\)](#)
 15. [20 USCA § 1232g\(j\)](#)
 16. [20 USCA § 1232g](#)
 17. [34 CFR § 99.30](#)
 18. [34 CFR § 99.32\(a\)](#)
- School District Records 1.407
Promotion and Retention 4.603
Testing Programs 4.700
Attendance 6.200
Withdrawals 6.207
Child Custody/Parental Access 6.209
Bus Safety and Conduct 6.308
Corporal Punishment 6.314
Disciplinary Hearing Authority 6.317
Admission of Suspended/Expelled Students 6.318
AIDS 6.404

Hickman County Board of Education

Descriptor Term: Student Records Annual Notification of Rights	Descriptor Code: 6.601	Issued Date: 08/07/23
	Rescinds: 6.601	Issued: 06/07/21

1 Within the first three weeks of each school year, the school system shall notify parent(s) of students and
2 eligible students* of each student's privacy rights.¹ For students enrolling after the above period, this
3 information shall be given to the student's parent(s) or the eligible student at the time of enrollment.²
4 The notice shall include the right of the student's parent(s) or the eligible student to:

- 5 1. Inspect and review the student's education records;
- 6 2. Seek correction of items in the record which are believed to be inaccurate, misleading or in
7 violation of the student's rights, including the right to a hearing upon request;
- 8 3. File a complaint with the appropriate state or federal officials when the school system violates
9 laws and regulations relative to student records;
- 10 4. Obtain a copy of this policy and a copy of the student's educational records;
- 11 5. Exercise control over other people's access to the records, except when prior written consent is
12 given, or under circumstances as provided by law or regulations, or where the school system has
13 designated certain information as "directory information." Parent(s) of students or eligible
14 students have two weeks after notification to advise the school system in writing of items they
15 designate not to be used as directory information. The records custodian shall mark the
16 appropriate student records for which directory information is to be limited, and this designation
17 shall remain in effect until it is modified by the written direction of the student's parent(s) or the
18 eligible student.

19 DIRECTORY INFORMATION

20 "Directory information" means information contained in an education record of a student which would
21 not generally be considered harmful or an invasion of privacy if disclosed. It includes, but is not limited
22 to the student's name, address, telephone number, e-mail address, photograph, date and place of birth,
23 dates of attendance, grade level, enrollment status, participation in officially recognized activities and
24 sports, weight and height of members of athletic teams, degrees, honors and awards received, and the
25 most recent educational agency or institution attended.³

26 Student directory information for 11th and 12th graders shall be made available upon request to persons
27 or groups which make students aware of occupational and educational options, including official
28 recruiting representatives of the military forces of the State and the United States.⁴

29 **The student becomes an "eligible student" when he/she reaches age 18 or enrolls in a post-secondary
30 school, at which time all of the above rights become the student's rights.⁵*

Legal References

1. 34 CFR §§ 99.4, 99.7
2. 34 CFR § 99.7
3. 34 CFR § 99.3
4. TCA 49-6-406; 10 USCA § 503(c)
5. 34 CFR §§ 99.3, 99.5; TCA 49-1-704

Hickman County Board of Education

Descriptor Term: Rights and Responsibilities of Students of Legal Age	Descriptor Code: 6.6011	Issued Date: 08/07/23
	Rescinds: 6.6011	Issued: 02/06/23

1 Every student eighteen (18) years of age or older shall be an eligible student as defined in Hickman
2 County Board of Education policy 6.601 and 6.6011. Such students, like all other students, shall
3 comply with the rules established, pursue the prescribed course of study, and submit to the authority of
4 teachers and other in a position of authority.

5 **FIELD TRIPS/ATHLETIC PROGRAMS**

6 Approved forms for participation shall be required of all students. The form should indicate that the
7 signature is that of the parent or guardian or the eligible student. Sponsors and/or coaches shall be
8 required to confirm the ages of those students signing their own forms.

9 **ATTENDANCE**

10 Notes submitted for attendance-related reasons, normally signed by parents/guardians, may be signed
11 by eligible students.

12 **DISCIPLINE PROCEDURES**

13 Discipline procedures and proceedings shall conform to the requirements established in board policies
14 for student discipline. Notification of discipline infractions shall continue to be communicated with
15 parents and/or guardians. Eligible students, however, are permitted to represent themselves upon
16 reinstatement to school following a suspension. If a student wants to represent himself or herself
17 without parental involvement, he or she shall sign a statement to that effect.

18 **WITHDRAWAL FROM SCHOOL**

19 Eligible students may withdraw from school without parent/guardian approval. Efforts shall be made to
20 contact parents/guardians and the students for a conference and explanation of the consequences that
21 may result from dropping out of school. Assistance shall be provided for educational opportunities that
22 are available to the student.

23 **REPORT CARDS**

24 Progress reports, reports cards, and other documents communicating student progress will be made
25 available to parents.

26 **RESIDENCE REQUIREMENTS**

- 1 The regulations pertaining to residence requirements shall pertain to eligible students.
- 2 **FINANCIAL RESPONSIBILITY**
- 3 Eligible students can be held financially responsible for damage to school property.

Cross References

Attendance 6.200
Student Records Annual Notification of Rights 6.601 Field
Trips, Excursions, Competitions 4.302 Interscholastic
Athletics 4.301
Athletic Regulations 4.3011
Textbooks 4.401
Reporting Student Progress 4.601
Interrogations and Searches 6.303
Discipline Procedures 6.313

Hickman County Board of Education

Descriptor Term:

Student Records Inspection & Correction Procedure

Descriptor Code:

6.602

Issued Date:

08/07/23

Rescinds:

6.602

Issued:

06/07/21

1 INSPECTION PROCEDURE

2 Parent(s) of students and eligible students* may inspect and review the student's education records upon written
3 request.¹

4 Parent(s) or eligible students shall submit to the records custodian a request which identifies as precisely as
5 possible the record(s) to inspect, and this inspection must be completed within 45 days from the receipt of the
6 request.

7 The right to inspect and review educational records includes the right to a response from school officials
8 concerning requests for explanation and interpretation of the data. School officials shall presume that the parent
9 has the authority to inspect and review records relating to his/her child unless the school sys-tem has been advised
10 that the parent does not have the authority under applicable state law governing guardianship, separation, and
11 divorce.²

12 When a record contains information about students other than the parent's child or the eligible student, the
13 parent(s) or eligible student may not inspect and review that information.²

14 FEES FOR COPIES

15 A reasonable fee for copies provided to parent(s) or eligible students shall be determined by the director of schools.
16 If the fee represents an unusual hardship, it may be waived in part or entirely by the records custodian.³

17 CORRECTION PROCEDURES

18 Parent(s) of students or eligible students may seek to change any part of the student's record they believe to be
19 incorrect.⁴ The director of schools shall develop an acceptable procedure to establish an orderly process to review
20 and potentially correct an education record.

21 **The student becomes an "eligible student" when he/she reaches age 18 or enrolls in a post-secondary school, at
22 which time all of the above rights become the student's rights.*

Legal References

1. 34 CFR §§ 99.3, 99.10; TCA 49-1-704
2. 34 CFR § 99.4
3. 34 CFR § 99.11
4. 34 CFR §§ 99.20, 99.21, 99.22

Hickman County School System

Inspection and Correction Procedures

6.602AP

Parents or eligible students may inspect and review the student's education records upon written request.

Procedure to inspect records:

- Submit an inspection request to the records custodian and identify as precisely as possible the records to inspect. When the student reaches age 18 or enrolls in postsecondary school, rights become the student's rights.
- Inspection of the records must be complete within 45 days from the receipt of the transcript request.
- Parents have the authority to inspect and review records unless that parent does not have the authority under applicable state law governing guardianship, separation, and divorce.

Correction procedures:

Parents of students or eligible students may seek to change any part of the student's record they believe to be incorrect. If there is a name change, change of address, change of contact information the parent should fill out a new enrollment form at the school the child attends. If the child has a name change the same process should be followed along with proof from the birth certificate of new name.

Hickman County Board of Education

Descriptor Term: Directory Information Procedure	Descriptor Code: 6.6031	Issued Date: 08/07/23
	Rescinds: 6.6031	Issued: 06/07/21

1 Statistical information not identified with a particular student may be released to any person, agency, or
2 the public.¹

3 “Directory Information” relating to a student includes the following: name, address, telephone listing,
4 date and place of birth, major field of study, participation in officially recognized activities and sports,
5 weight and height of members of athletic teams, dates of attendance, degrees and awards received and
6 the most recent or previous educational agency or institution attended by the student.²

7 Within the first three weeks of each school year, the school district will notify parents and eligible
8 students* of the items it proposes to designate as “directory information.” For students enrolling after
9 this notice is published, a list of the directory items will be given to the student’s parent(s) or eligible
10 student at the time and place of enrollment.³

11 After the parent(s) or eligible students have been notified, they will have two weeks to advise the school
12 system in writing (a letter to the director of schools’ office) of any or all of the items they refuse to permit
13 the school system to designate as directory information about that student. At the end of the two-week
14 period, each student’s records will be appropriately marked by the records custodian to indicate the items
15 the school system will designate as directory information about that student. This designation will
16 remain in effect until it is modified by the written direction of the student’s parent(s) or the eligible
17 student.³

18 Student directory information for 11th and 12th graders shall be made available upon request to persons
19 or groups which make students aware of occupational and educational options, including official
20 recruiting representatives of the military forces of the State and the United States.⁴

21 **The student becomes an “eligible student” when he/she reaches age 18 or enrolls in a post-secondary*
22 *school, at which time all of the above rights become the student’s rights.*

Legal References

1. TCA 10-7-504(b)
2. 20 USCA 1232g(a)(5)(A)
3. 20 USCA 1232g(a)(5)(B)
4. TCA 49-6-406

Hickman County Board of Education

	Descriptor Term: Media Access to Students	Descriptor Code: 6.604	Issued Date: 08/07/23
		Rescinds: 6.604	Issued: 06/07/21

1 School administrators shall be authorized to grant permission and set parameters for media access to
2 students in their respective schools. Media representatives shall be required to report to the
3 administration for prior approval before accessing students involved in instructional programs and
4 activities not attended by the general public. The media may interview and photograph students involved
5 in instructional programs and school activities including athletic events. Such media access shall not be
6 unduly disruptive and shall comply with Board policies.

7 Each year parents/guardians will be given the option to withhold permission for public news media
8 interviews or photographs of their child at school.

9 Specific parental/guardian permission must be obtained if the story or photograph covers topics of a
10 sensitive nature.

11 If any student is to be filmed or videotaped and will be identified or a primary subject of the filming or
12 videotaping, prior written consent/release/waiver will be obtained from the student's parent/guardian.

13 District employees may release student information to the media only in accordance with applicable
14 provisions of the education records law and Board policies governing directory information and
15 personally identifiable information.¹

16 Parents will be advised of the Board's media access to students policy at the time of the student's
17 registration and each fall in the student/parent handbook.

Legal References

1. 20 USCA § 1232g; TRR/MS 0520-01-03-.03(11)

Cross References

News Releases, News Conferences, and Interviews 1.503

Hickman County Board of Education

	Descriptor Term: Student Publications	Descriptor Code: 6.704	Issued Date: 08/07/23
		Rescinds: 6.704	Issued: 06/07/21

1 STUDENT RIGHTS

2 The student shall be allowed to responsibly express himself/herself and to disseminate his/her views in
3 writing.¹

4 Any student may submit articles and editorials for school-sponsored publications. The procedure for
5 submission of materials shall be published and distributed to all students.

6 STANDARDS

7 School-sponsored publications shall adhere to commonly accepted community standards, and no printed
8 material may be distributed which:

- 9 1. Is obscene³
- 10 2. Is libelous
- 11 3. May create a material and substantial disruption of the normal school activity or appropriate
12 discipline in the school.

13 CONTROL AND SUPERVISION

14 Student publications shall be under the control of the principal. Each school shall have a faculty sponsor
15 who reviews all publications proposed to be distributed in the school by a student or school group.²

16 DISTRIBUTION

17 School authorities shall regulate the time, manner, place and duration for the distribution of publications
18 on school grounds.

19 As it pertains to the school, distribution shall be defined as any manner of disseminating written or
20 printed materials equally, systematically or merely at random to several or many persons on school
21 grounds.

22 APPEALS

23 If a request for distributing any portion of a student publication is denied by the faculty sponsor, the
24 decision may be appealed to the principal, then to the director of schools, and ultimately to the Board.

Legal References

1. U.S. Constitution, Amendment 1
2. *Tinker v. Des Moines Independent Community District*, 393 U.S. 503 (1969)
3. *Shamley v. Northwest Ind. School District*, 462 F. 2d 960, 970-71, 5th Cir., 1972

Cross References

- Use of Copyrighted Materials 4.404
- Use of the Internet 4.406
- Web Pages 4.407
- Controversial Issues 4.800

Hickman County Board of Education

Descriptor Term: Student Fees and Fines	Descriptor Code: 6.709	Issued Date: 08/07/23
	Rescinds: 6.709	Issued: 06/07/21

1 School fees are defined as follows:¹

- 2 1. Fees for activities that occur during regular school hours, including field trips;
- 3 2. Fees for activities and supplies required to participate in all courses offered for credit or grades;
- 4 3. Equipment and supplies required to participate in interscholastic athletics and marching band, if
- 5 taken for credit;
- 6 4. Fees or tuition for courses taken for credit or grade during summer school;
- 7 5. Fees required for graduation ceremonies;
- 8 6. Fees for a copy of the student's records; and
- 9 7. Refundable deposits for locks or other security devices required for protection of school
- 10 property when used in conjunction with courses taken for credit or a grade.

11 School fees are not:¹

- 12 1. Fines for overdue library books;
- 13 2. Fines for the abuse of school parking privileges and other school rules developed for the safe
- 14 and efficient operation of the school;
- 15 3. Charges for lost, damaged, or destroyed textbooks, library books, workbooks, or other school
- 16 property;
- 17 4. Charges for debts owed the school;
- 18 5. Refundable deposits for locks or other security devices required for protection of school
- 19 property when used in not-for-credit extracurricular activities;
- 20 6. Costs to participate in not-for-credit extracurricular activities, including athletics; and
- 21 7. Tuition for non-resident students.

22 No fee will be charged any student as a condition to attending school,² but students shall be responsible

23 for normal school supplies, such as pencils and paper.

24 School fees shall be waived for students who receive free or reduced-price school lunches. The

25 application for determining eligibility for free or reduced-price lunches or a form supplied by the State

26 Department of Education shall be used to verify student eligibility for fee waivers.

27 At the beginning of the school year, each principal shall be responsible for providing to all students

28 and their parents or guardians written notice of the required student fees and the process for fee waiver

29 for students who receive free or reduced-price lunches. The parent or guardian of an eligible student

30 must sign the appropriate application for free or reduced-price lunches and the waiver of school fees,

31 but may pay for all or a portion of the school fees.

32 Written notice of approval or denial of request for fee waivers shall be provided to all parents or

33 guardians. Any denial shall contain specific grounds for denial and an opportunity for the parent or

34 guardian to meet with appropriate school personnel.

1 Persons collecting fees shall be provided a list containing only the names of those students eligible for
2 waivers and for whom they are responsible for collecting fees. Any records related to this program
3 which identify particular students shall be maintained in strictest confidence.

4 Prior to the beginning of school each year, the Board, upon the recommendation of the principals and
5 superintendent, shall approve all student fees for the upcoming school year. Additional fees may be
6 approved during the year as needed. The superintendent shall be responsible for maintaining copies of
7 all correspondence relating to this program.

8 No employee may charge a student for any service rendered on the school premises. Tutoring one's
9 own student for pay is prohibited.

10 **FINES³**

11 Students who destroy, damage, or lose school property, including but not limited to buildings, school
12 buses, books, equipment, and records, will be responsible for the actual cost of replacing or repairing
13 such materials or equipment.

14 The grades, grade cards, diploma or transcript of a student who is responsible for vandalism or theft or
15 who has otherwise incurred a debt to a school may be held until the student or the student's
16 parent/guardian has paid for the damages. When the student and parent are unable to pay the debt, the
17 district shall provide a program of voluntary work for the minor. Upon completion of the work, the
18 student's grades, diploma, and/or transcripts shall be released. Such sanctions shall not be imposed if
19 the student is not at fault.⁴

20 Failure to remit the cost of replacing or repairing such materials or to make satisfactory arrangements
21 with the administration for payment may result in suspension of the student. If payment is not
22 remitted, the matter will be referred to the Board for final disposition.

23 Textbooks are available free to students as a loan. Parent(s) will accept full responsibility for the
24 proper care, preservation, return, or replacement of textbooks issued to the student(s). The condition
25 of each book and a book number shall be recorded by the teacher issuing it.

26 The life of the book is considered to be six (6) years. Charges for lost books will be the remaining life
27 of the book. Damage fines will be based on the wear beyond that normally expected for one year. For
28 one year's wear there will be no charge.

29 Fines may be assessed for overdue, damaged, or lost library books. In no event will the fine exceed the
30 current cost of replacing the book.

1. TCA 49-2-114; TRR/MS 0520-01-02-.16
2. TCA 49-6-3001(a); TCA 49-2-110(c)
3. TCA 37-10-101, 102
4. TRR/MS 0520-01-02-.16

Revenues 2.400
Textbooks 4.401
Care of School Property 6.311

PROPOSED FUNDRAISING ACTIVITIES

Fund/account name Bookfair / Library (Spring)

Proposed fundraising activities: School Book Fair

Purposed Uses of funds raised

EHES Library

Expected student involvement (school-wide or specific school organization) _____

school-wide

Method by which school will receive profit Check

Requested by Rebekah Sorensen, Librarian Date 9/5/2025
Name/Title

Approved by Leisha Coble Date 9/8/25
Principal

Approved by John Mullins Date 9/8/25
Director of Schools*

* The Director of Schools must approve all fundraising activities that involve the participation of the general student population in the marketing process of the fundraising effort.

PROPOSED FUNDRAISING ACTIVITIES

Fund/account name Breakfast w/ Santa

Proposed fundraising activities: Breakfast with Santa will include a pancake breakfast, hot cocoa, coloring, and pictures with Santa.

Purposed Uses of funds raised Community Involvement

Expected student involvement (school-wide or specific school organization) Breakfast with Santa will involve students from our school and district.

Method by which school will receive profit Cash or Check

Requested by Michelle O'Leary Date 9/5/25
Name/Title

Approved by Leigha Coble Date 9/8/25
Principal

Approved by John Mullins Date 9-10-25
Director of Schools*

* The Director of Schools must approve all fundraising activities that involve the participation of the general student population in the marketing process of the fundraising effort.

PROPOSED FUNDRAISING ACTIVITIES

Fund/account name Book Fair / Library (Fall)

Proposed fundraising activities: School Book Fair

Purposed Uses of funds raised

EHS Library

Expected student involvement (school-wide or specific school organization) _____

school-wide

Method by which school will receive profit check

Requested by Rebekah Sorensen, Librarian
Name/Title

Date 9/5/2025

 Approved by _____
Principal

Date _____ 

Approved by John Mullins
Director of Schools*

Date 9-10-25

* The Director of Schools must approve all fundraising activities that involve the participation of the general student population in the marketing process of the fundraising effort.

PROPOSED FUNDRAISING ACTIVITIES

Fund/account name Spirit wear

Proposed fundraising activities: Selling shirts, long sleeve
and Hoodies

Purposed Uses of funds raised Instructional Supplies

Expected student involvement (school-wide or specific school organization) School wide

Method by which school will receive profit Cash, check
or online

Requested by Darlene Saleh / Bookkeeper Date 9-4-25
Name/Title

Approved by Reisha Coble Date 9/4/25
Principal

Approved by John Mullins Date 9-8-25
Director of Schools*

* The Director of Schools must approve all fundraising activities that involve the participation of the general student population in the marketing process of the fundraising effort.

PROPOSED FUNDRAISING ACTIVITIES

Fund/account name Student Engagement / Incentives

Proposed fundraising activities: School Store

Purposed Uses of funds raised

student engagement and academic incentives

Expected student involvement (school-wide or specific school organization) _____

School wide

Method by which school will receive profit check

Requested by Amy McAbee
Name/Title

Date 9/22/25

Approved by Amy McAbee
Principal

Date 9/22/25

Approved by John Mullins
Director of Schools*

Date 9-22-25

* The Director of Schools must approve all fundraising activities that involve the participation of the general student population in the marketing process of the fundraising effort.

Tennessee Internal School Uniform Accounting Policy Manual
Applicable Laws and Exhibits-Appendix A

Exhibit 1

PROPOSED FUNDRAISING ACTIVITIES

Fund/account name Library - Book Fair

Proposed fundraising activities: Fall Book Fair

Oct. 17 - Oct. 24, 2025

Purposed Uses of funds raised

Library Books and Supplies

Expected student involvement (school-wide or specific school organization)

School-Wide

Method by which school will receive profit profit calculated and

withheld from amt paid to Scholastic

Requested by Michelle Atkinson Date 9-2-25
Name/Title

Approved by Amy McAlister Date 9-2-25
Principal

Approved by John Mullins Date 9-2-25
Director of Schools*

* The Director of Schools must approve all fundraising activities that involve the participation of the general student population in the marketing process of the fundraising effort.

Tennessee Internal School Uniform Accounting Policy Manual
Applicable Laws and Exhibits-Appendix A

Exhibit 1

PROPOSED FUNDRAISING ACTIVITIES

Fund/account name School Pictures

Proposed fundraising activities: individual school pictures - Fall

individual/group - Spring

Purposed Uses of funds raised General Fund - instructional Supplies

Expected student involvement (school-wide or specific school organization) _____

School wide

Method by which school will receive profit check - \$1250 for

each fall and Spring picture sales

Requested by Jina Truett, Bookkeeper Date 9-2-25
Name/Title

Approved by Amy McAlwee Date 9/2/25
Principal

Approved by John Mullins Date 9/2/25
Director of Schools*

* The Director of Schools must approve all fundraising activities that involve the participation of the general student population in the marketing process of the fundraising effort.

Tennessee Internal School Uniform Accounting Policy Manual
Applicable Laws and Exhibits-Appendix A

Exhibit 1

PROPOSED FUNDRAISING ACTIVITIES

Fund/account name Fundraising

Proposed fundraising activities: School Store

Purposed Uses of funds raised

Student incentives for behavior and attendance

Expected student involvement (school-wide or specific school organization)

School wide

Method by which school will receive profit check

Requested by Jina Truett, Bookkeeper Date 9-2-25
Name/Title

Approved by Amy McAlister Date 9/2/25
Principal

Approved by John Mullins Date 9/2/25
Director of Schools*

* The Director of Schools must approve all fundraising activities that involve the participation of the general student population in the marketing process of the fundraising effort.

Exhibit 1

PROPOSED FUNDRAISING ACTIVITIES

Fund/account name: Fundraising

Proposed fundraising activities: Eagle Strut Event

Purposed Uses of funds raised
ABIS supplies, school supplies, ELA
and math materials to increase
student scores.

Expected student involvement (school-wide or specific school organization) School-wide
Students will collect donations,
purchase spirit shirts, concession and class

Method by which school will receive profit Donations baskets
for
auction

Requested by Deana Graham
Name/Title:

Date 9-11-2025

Approved by Kathy Dick
Principal

Date 9-11-25

Approved by John Mullins
Director of Schools*

Date 9-12-25

*The Director of Schools must approve all fundraising activities that involve the participation of the general student population in the marketing process of the fundraising effort.

PROPOSED FUNDRAISING ACTIVITIES

Fund/account name Rewards

Proposed fundraising activities: Afterschool "Hang out"

Purposed Uses of funds raised
Support rewards for students + teachers

Expected student involvement (school-wide or specific school organization) School wide

Method by which school will receive profit currency

Requested by Felicity Howell LPN Date 10.2.25
Name/Title

Approved by [Signature] Date 10/3/25
Principal

Approved by [Signature] Date 10/3/25
Director of Schools*

* The Director of Schools must approve all fundraising activities that involve the participation of the general student population in the marketing process of the fundraising effort.

PROPOSED FUNDRAISING ACTIVITIES

Fund/account name Library

Proposed fundraising activities: Book Fair

Purposed Uses of funds raised

Books and Supplies

Expected student involvement (school-wide or specific school organization) _____

School Wide

Method by which school will receive profit Scholastic Dollars

Requested by Robin DeLaune Date 9/12/25
Name/Title

Approved by Jina S. Shugart Date 9-12-25
Principal

Approved by John Mullins Date 9-12-25
Director of Schools*

* The Director of Schools must approve all fundraising activities that involve the participation of the general student population in the marketing process of the fundraising effort.

PROPOSED FUNDRAISING ACTIVITIES

Fund/account name Rewards

Proposed fundraising activities: sell pieces of gym floor

Purposed Uses of funds raised

 Rewards

Expected student involvement (school-wide or specific school organization)

 Whole school

Method by which school will receive profit Funds from

 market sale

Requested by Zach Bentley / AP Date 9-8-25
Name/Title

Approved by Tina S. Shepper Date 9-8-25
Principal

Approved by John Mullens Date 9-10-25
Director of Schools*

* The Director of Schools must approve all fundraising activities that involve the participation of the general student population in the marketing process of the fundraising effort.

PROPOSED FUNDRAISING ACTIVITIES

Fund/account name GIRLS + BOYS BASKETBALL

Proposed fundraising activities: After School Hangout before the Volleyball game on 9/17

Purposed Uses of funds raised
TEAM GEAR + EQUIPMENT

Expected student involvement (school-wide or specific school organization) _____

Boys + Girls Basketball Program Parents

Method by which school will receive profit CASH

Requested by Ron Purcell / Coach Date 9/3/25
Name/Title

Approved by Ima S. Shupp Date 9-3-25
Principal

Approved by John Mullens Date 9.8.25
Director of Schools*

* The Director of Schools must approve all fundraising activities that involve the participation of the general student population in the marketing process of the fundraising effort.

PROPOSED FUNDRAISING ACTIVITIES

Fund/account name Rewards

Proposed fundraising activities: Kona Ice - Occasionally
throughout the school year (Reward Times + Games)

Purposed Uses of funds raised Rewards for students &
teachers.

Expected student involvement (school-wide or specific school organization) _____
School-wide (those that wish to participate)

Method by which school will receive profit Currency - they send us
a check based on a percentage of their profits.

Requested by [Signature] Date 9-5-25
Name/Title

Approved by [Signature] Date 9-5-25
Principal

Approved by [Signature] Date 9-5-25
Director of Schools*

* The Director of Schools must approve all fundraising activities that involve the participation of the general student population in the marketing process of the fundraising effort.

PROPOSED FUNDRAISING ACTIVITIES

Fund/account name Rewards Ops & Maint

Proposed fundraising activities: Annual Spike Hike Walking Event

Purposed Uses of funds raised Raise funds to install a carport in the back parking lot for our students in a wheel chair (so they won't get wet when its raining)

Expected student involvement (school-wide or specific school organization) School-wide (those that wish to participate)

Method by which school will receive profit Currency

Requested by Zel BA Date 9-2-25
Name/Title

Approved by Ima S. Shupe Date 9-2-25
Principal

Approved by John Mullins Date 9-2-25
Director of Schools*

* The Director of Schools must approve all fundraising activities that involve the participation of the general student population in the marketing process of the fundraising effort.

PROPOSED FUNDRAISING ACTIVITIES

Fund/account name Beta Club

Proposed fundraising activities: tailgate party for
Homecoming Football games

Purposed Uses of funds raised
to attend convention

Expected student involvement (school-wide or specific school organization) _____
School wide

Method by which school will receive profit monetary

Requested by Kim Totty / Beta Sponsor Date 9-3-25
Name/Title

Approved by [Signature] Date 9-3-25
Principal

Approved by [Signature] Date 9-4-25
Director of Schools*

* The Director of Schools must approve all fundraising activities that involve the participation of the general student population in the marketing process of the fundraising effort.

Ad Sponsors for
EHHS Theatre

PROPOSED FUNDRAISING ACTIVITIES



East Hickman High School
7700 Hwy 7, Lyles, TN 37098
Phone 931-670-1366 Fax 931-670-1039

Fund/Account Name Theater

Account Number 806

Proposed fundraising activities: Students ask family, staff, businesses, etc if they would like to purchase ad/shoutout space in our play program.

Purposed Uses of funds raised: purchase future equipment and production rights for EHHS theatre.

Expected Student involvement (school-wide or specific school organization): Fall play cast and crew

Method by which school will receive profit: Cash or check

Requested by: Vinny Caccese - Theatre Teacher 10/1/25
Name/Title Date

Acknowledge by: [Signature] 10/1/25
Bookkeeper Date

Approved by: [Signature] 10/3/25
Principal Date

Approved by: [Signature] 10/13/25
Director of Schools* Date

* The Director of Schools must approve all fundraising activities that involve the participation of the general student population in the marketing process of the fundraising effort.



SCHOOL SUPPORT ORGANIZATIONS PROPOSED FUNDRAISING ACTIVITIES

(Pursuant to Section 49-2-604, TCA,

To be submitted prior to scheduling any fundraising activity.)

IN COMPLIANCE WITH SCHOOL BOARD POLICY 2.404 AND TCA SECTION 49-2-601 ET SEQ., OUR SCHOOL SUPPORT ORGANIZATION SUBMITS THIS PROPOSED FUNDRAISING ACTIVITY FOR THE DIRECTOR'S APPROVAL. WE REALIZE THAT THE DIRECTOR SHALL CONSIDER, AT A MINIMUM, THE FOLLOWING WHEN APPROVING OR DENYING A REQUEST BY A SCHOOL SUPPORT ORGANIZATION TO ENGAGE IN A FUNDRAISING ACTIVITY:

- 1) Whether the fundraising activity, as scheduled, conflicts with the fundraising activity of the school district or an individual school within the district, and
- 2) Whether the fundraising activity is consistent with the goals and mission of the school and/or the school district.

The undersigned submits that this fundraising activity is consistent with the goals and mission of the school and/or the school district, as well as the organization's mission, goals, and objectives.

ORGANIZATION: EH Marching Eagles

DATE OF PROPOSED FUNDRAISING Oct - Nov 2025

PROPOSED FUNDRAISING ACTIVITY: Candle Sales

PROPOSED USES OF FUNDS RAISED: Support Comp fees

OTHER COMMENTS/CONSIDERATIONS RELATED TO THE FUNDRAISER:

REQUESTED BY Shani Fitzgerald - Treasurer DATE 9.29.25
Signature/Title

REVIEWED BY Carol Mark DATE 9.30.25 *gpm*
School Principal Designee

APPROVED BY John Mullins DATE 10-1-25
Director of Schools Designee



SCHOOL SUPPORT ORGANIZATIONS PROPOSED FUNDRAISING ACTIVITIES

(Pursuant to Section 49-2-604, TCA,
To be submitted prior to scheduling any fundraising activity.)

IN COMPLIANCE WITH SCHOOL BOARD POLICY 2.404 AND TCA SECTION 49-2-601 ET SEQ., OUR SCHOOL SUPPORT ORGANIZATION SUBMITS THIS PROPOSED FUNDRAISING ACTIVITY FOR THE DIRECTOR'S APPROVAL. WE REALIZE THAT THE DIRECTOR SHALL CONSIDER, AT A MINIMUM, THE FOLLOWING WHEN APPROVING OR DENYING A REQUEST BY A SCHOOL SUPPORT ORGANIZATION TO ENGAGE IN A FUNDRAISING ACTIVITY:

- 1) Whether the fundraising activity, as scheduled, conflicts with the fundraising activity of the school district or an individual school within the district, and
- 2) Whether the fundraising activity is consistent with the goals and mission of the school and/or the school district.

The undersigned submits that this fundraising activity is consistent with the goals and mission of the school and/or the school district, as well as the organization's mission, goals, and objectives.

ORGANIZATION: Ett Marching Eagles

DATE OF PROPOSED FUNDRAISING Oct 11th 2025

PROPOSED FUNDRAISING ACTIVITY: Car-Wash - Shyms

PROPOSED USES OF FUNDS RAISED: paying for buses end of season

OTHER COMMENTS/CONSIDERATIONS RELATED TO THE FUNDRAISER:

REQUESTED BY Shawn Fitzgerald/treasurer DATE 9-29-25
Signature/Title

REVIEWED BY Cayla Mount DATE 9-30-25
School Principal/Designee

APPROVED BY John Mullens DATE 10-1-25
Director of Schools/Designee



SCHOOL SUPPORT ORGANIZATIONS PROPOSED FUNDRAISING ACTIVITIES

(Pursuant to Section 49-2-604, TCA,
To be submitted prior to scheduling any fundraising activity.)

IN COMPLIANCE WITH SCHOOL BOARD POLICY 2.404 AND TCA SECTION 49-2-601 ET SEQ., OUR SCHOOL SUPPORT ORGANIZATION SUBMITS THIS PROPOSED FUNDRAISING ACTIVITY FOR THE DIRECTOR'S APPROVAL. WE REALIZE THAT THE DIRECTOR SHALL CONSIDER, AT A MINIMUM, THE FOLLOWING WHEN APPROVING OR DENYING A REQUEST BY A SCHOOL SUPPORT ORGANIZATION TO ENGAGE IN A FUNDRAISING ACTIVITY:

- 1) Whether the fundraising activity, as scheduled, conflicts with the fundraising activity of the school district or an individual school within the district, and
- 2) Whether the fundraising activity is consistent with the goals and mission of the school and/or the school district.

The undersigned submits that this fundraising activity is consistent with the goals and mission of the school and/or the school district, as well as the organization's mission, goals, and objectives.

ORGANIZATION: ETH Marching Eagles

DATE OF PROPOSED FUNDRAISING Oct - Nov 2025

PROPOSED FUNDRAISING ACTIVITY: Pick a date Calendar

PROPOSED USES OF FUNDS RAISED: Support band in all needs

OTHER COMMENTS/CONSIDERATIONS RELATED TO THE FUNDRAISER:

REQUESTED BY Shari Fitzgerald - Treasurer DATE 9-29-25

REVIEWED BY Cayla M... [Signature] DATE 9-30-25

APPROVED BY John Mullins DATE 10-1-25

Director of Schools/Designee



SCHOOL SUPPORT ORGANIZATIONS PROPOSED FUNDRAISING ACTIVITIES

(Pursuant to Section 49-2-604, TCA,
To be submitted prior to scheduling any fundraising activity.)

IN COMPLIANCE WITH SCHOOL BOARD POLICY 2.404 AND TCA SECTION 49-2-601 ET SEQ., OUR SCHOOL SUPPORT ORGANIZATION SUBMITS THIS PROPOSED FUNDRAISING ACTIVITY FOR THE DIRECTOR'S APPROVAL. WE REALIZE THAT THE DIRECTOR SHALL CONSIDER, AT A MINIMUM, THE FOLLOWING WHEN APPROVING OR DENYING A REQUEST BY A SCHOOL SUPPORT ORGANIZATION TO ENGAGE IN A FUNDRAISING ACTIVITY:

- 1) Whether the fundraising activity, as scheduled, conflicts with the fundraising activity of the school district or an individual school within the district, and
- 2) Whether the fundraising activity is consistent with the goals and mission of the school and/or the school district.

The undersigned submits that this fundraising activity is consistent with the goals and mission of the school and/or the school district, as well as the organization's mission, goals, and objectives.

ORGANIZATION: EH Marching Eagles
 DATE OF PROPOSED FUNDRAISING: ~~From~~ Oct - Nov - Dec 25
 PROPOSED FUNDRAISING ACTIVITY: Butter Bread Sales

PROPOSED USES OF FUNDS RAISED: Support band members

OTHER COMMENTS/CONSIDERATIONS RELATED TO THE FUNDRAISER:

REQUESTED BY Shari Fitzgerald - Treasurer DATE 9.29.25
Signature/Title

REVIEWED BY Cyle Mault DATE 9.30.25 *gms*
School Principal/Designee

APPROVED BY John Mullins DATE 10-1-25
Director of Schools/Designee

PROPOSED FUNDRAISING ACTIVITIES



East Hickman High School
7700 Hwy 7, Lyles, TN 37098
Phone 931-670-1366 Fax 931-670-1039

Fund/Account Name

Pep Club

Account Number

Proposed fundraising activities:

Battle of the Bentley's

Purposed Uses of funds raised:

Blessing box & ~~Research~~ PBIS

(Competition Video's for Rivalry Week)

Expected Student involvement (school-wide or specific school organization):

School wide

Method by which school will receive profit:

Cash

Requested by:

Beth Copley / School Counselor
Name/Title

9/24/25
Date

Acknowledge by:

[Signature]
Bookkeeper

9/24/25
Date

Approved by:

[Signature]
Principal

Date

Approved by:

[Signature]
Director of Schools*

9-24-25
Date

* The Director of Schools must approve all fundraising activities that involve the participation of the general student population in the marketing process of the fundraising effort.

PROPOSED FUNDRAISING ACTIVITIES

Fund/account name Graduation Fund

Proposed fundraising activities: Annual Lip Sync

Purposed Uses of funds raised Graduation for class of
2026

Expected student involvement (school-wide or specific school organization) _____

Anyone may participate, teachers, staff, Parents,
Students.

Method by which school will receive profit ticket sales - 5th eve
performance, 2nd day show

Requested by Tracy Poth / teacher Date 9/22/25
Name/Title ggw

Approved by [Signature] Date _____
Principal

Approved by John Mullins Date 9-22-25
Director of Schools*

* The Director of Schools must approve all fundraising activities that involve the participation of the general student population in the marketing process of the fundraising effort.

PROPOSED FUNDRAISING ACTIVITIES



East Hickman High School
7700 Hwy 7, Lyles, TN 37098
Phone 931-670-1366 Fax 931-670-1039

Fund/Account Name HOSA

Account Number _____

Proposed fundraising activities:

World Best Chocolate

Purposed Uses of funds raised:

to raise money for HOSA

Expected Student involvement (school-wide or specific school organization):

HOSA will be selling to the whole school

Method by which school will receive profit:

CASH

Requested by:

Miranda England
Name/Title

9.23.25
Date

Acknowledge by:

JAN

Bookkeeper

9/23/25

Date

Approved by:

[Signature]
Principal

9/23/25

Date

Approved by:

John Mullins
Director of Schools*

9.20.25

Date

* The Director of Schools must approve all fundraising activities that involve the participation of the general student population in the marketing process of the fundraising effort.

PROPOSED FUNDRAISING ACTIVITIES



East Hickman High School
7700 Hwy 7, Lyles, TN 37098
Phone 931-670-1366 Fax 931-670-1039

Fund/Account Name Journalism - The Eagle's Eye

Account Number 000813

Proposed fundraising activities: Little Caesar's Pizza

Purposed Uses of funds raised: This will be used for funding the trip to National Journalism Conference

Expected Student involvement (school-wide or specific school organization): Those going on the trip will participate.

Method by which school will receive profit: Online sales - check to school

Requested by: Connie Graves
Name/Title

9/9/2025
Date

Acknowledge by: [Signature]
Bookkeeper

Date

Approved by: [Signature]
Principal

9/10/25
Date

Approved by: [Signature]
Director of Schools*

9-12-25
Date

* The Director of Schools must approve all fundraising activities that involve the participation of the general student population in the marketing process of the fundraising effort.

PROPOSED FUNDRAISING ACTIVITIES



East Hickman High School
7700 Hwy 7, Lyles, TN 37098
Phone 931-670-1366 Fax 931-670-1039

Fund/Account Name Girls Soccer

Account Number _____

Proposed fundraising activities: Krispy Kreme Doughnuts

Purposed Uses of funds raised: General expenses

Expected Student involvement (school-wide or specific school organization): Team Only

Method by which school will receive profit: Cash & Checks

Requested by: Wendell Gordon - Head Coach 9-9-2025
Name/Title Date

Acknowledge by: [Signature] _____
Bookkeeper Date

Approved by: [Signature] 9-12-25
Principal Date

Approved by: [Signature] 9-12-25
Director of Schools* Date

* The Director of Schools must approve all fundraising activities that involve the participation of the general student population in the marketing process of the fundraising effort.

PROPOSED FUNDRAISING ACTIVITIES



East Hickman High School
7700 Hwy 7, Lyles, TN 37098
Phone 931-670-1366 Fax 931-670-1039

Fund/Account Name Art Club

Account Number 834

Proposed fundraising activities: Calendar Sale - students will create images to be used in the calendar.

Purposed Uses of funds raised: Supplies for National Art Honor Society projects including service project (Memory Project) and paint to continue the unfinished mural in the Fine Arts hallway.

Expected Student involvement (school-wide or specific school organization): Student members of National Art Honor Society

Method by which school will receive profit: We will pre-sell (take orders & collect money) calendars for \$20 each. Calendars will be designed and printed at calendarfundraising.com.*

Requested by: Jennifer Allman / Art Teacher; NAHS Sponsor 9/11/25
Name/Title Date

Acknowledge by: [Signature] 9/11/25
Bookkeeper Date

Approved by: [Signature] 9/11/25
Principal Date

Approved by: [Signature] 9-12-25
Director of Schools* Date

* The Director of Schools must approve all fundraising activities that involve the participation of the general student population in the marketing process of the fundraising effort.

*prices range from \$14.50-8.50 per calendar depending on how many we sell. Leftover funds will remain in the Art Club account.



SCHOOL SUPPORT ORGANIZATIONS PROPOSED FUNDRAISING ACTIVITIES

(Pursuant to Section 49-2-604, TCA,

To be submitted prior to scheduling any fundraising activity.)

IN COMPLIANCE WITH SCHOOL BOARD POLICY 2.404 AND TCA SECTION 49-2-601 ET SEQ., OUR SCHOOL SUPPORT ORGANIZATION SUBMITS THIS PROPOSED FUNDRAISING ACTIVITY FOR THE DIRECTOR'S APPROVAL. WE REALIZE THAT THE DIRECTOR SHALL CONSIDER, AT A MINIMUM, THE FOLLOWING WHEN APPROVING OR DENYING A REQUEST BY A SCHOOL SUPPORT ORGANIZATION TO ENGAGE IN A FUNDRAISING ACTIVITY:

- 1) Whether the fundraising activity, as scheduled, conflicts with the fundraising activity of the school district or an individual school within the district, and
2) Whether the fundraising activity is consistent with the goals and mission of the school and/or the school district.

The undersigned submits that this fundraising activity is consistent with the goals and mission of the school and/or the school district, as well as the organization's mission, goals, and objectives.

ORGANIZATION: EHHS Eagles Soccer

DATE OF PROPOSED FUNDRAISING On or before October 15, 2025

PROPOSED FUNDRAISING ACTIVITY: Team only Car Wash

PROPOSED USES OF FUNDS RAISED: Field Maintainance and Equipment

OTHER COMMENTS/CONSIDERATIONS RELATED TO THE FUNDRAISER:

REQUESTED BY Tanika M. Cox DATE 9/4/25

REVIEWED BY [Signature] DATE 9/5/25

APPROVED BY John Mullins DATE 9-5-05

PROPOSED FUNDRAISING ACTIVITIES



East Hickman High School
7700 Hwy 7, Lyles, TN 37098
Phone 931-670-1366 Fax 931-670-1039

Fund/Account Name Dep Club

Account Number _____

Proposed fundraising activities: Homecoming Dance

Purposed Uses of funds raised: Student activities

Expected Student involvement (school-wide or specific school organization): school wide

Method by which school will receive profit: cash

Requested by: Both Copley Sponsor 9/4/25
Name/Title Date

Acknowledge by: [Signature] _____
Bookkeeper Date

Approved by: [Signature] _____
Principal Date

Approved by: John Mullins 9-8-25
Director of Schools* Date

* The Director of Schools must approve all fundraising activities that involve the participation of the general student population in the marketing process of the fundraising effort.

Proposed Fundraising Activities



East Hickman High School
7700 Hwy 7, Lyles, TN 37098
Phone: 931-670-1366 Fax: 931-670-1039

Fund / Account Name: East Hickman Future Farmers of America 0315

Account Number: 831

Proposed Fundraising Activities: Water Sales

Proposed Uses of Funds Raised :

Monies earned from the sale of water at the Annual Soap Box Derby Race will go to promote FFA and Greenhouse activities for the 2025 - 2026 School year.

Expected Student Involvement (School-wide or Specific School Organization):

All students will be able to purchase bottled water through EHHS FFA

Method by which school will receive profit:

Water will cost one (\$1:00) dollar.

Requested By (Name and Title):

Myles Keogh Williams, EHHS Ag

Date: 8/5/2025

JKW

Approved By (Principal):

[Signature]

Date: _____

Approved By (Director of Schools):

John Mullins

Date: _____

9-8-25

*The Director of Schools must approve all fundraising activities that involve the participation of the general population in the marketing process of the fundraising effort.

Revised 4/20/19

Fundraiser Request

The activity sponsor is to complete the fundraiser request form and submit it to the building principal.

Fundraising Activity: FBLA Dues
 Activity Fund/Account Name: FBLA
 Activity Sponsor: Morgan
 Purpose of Project: CTSO Dues
 Date of Project: 9-4-25 Length of Project: 1 month
 Company Name: FBLA
 Company Address: 12100 Sunset Hills Rd, Reston, VA 20190
 Representative Name: N/A Phone: _____
 Quantity to be Ordered: ? Cost per Unit: \$15
 Proposed Sales Price per Unit: \$15 Total Dollar Goal: ?
 Requested by: Cindi Morgan Adviser 8-29-25
Sponsor's Name & Title 8/29/25 Date
 Approved by: [Signature] _____
Principal Date
 Approved by: John Mullins 9-4-25
Director of Schools (if applicable) Date

Fundraiser Summary Report

The following section is to be completed at the conclusion of the project.

Total Collections	\$ _____	Supported by Fundraiser Summary Report
Less Total Expenses	\$ _____	Be specific in reporting total expenses
Total Fundraiser Profit	\$ _____	
Less Intended Purchases	\$ _____	Proof of purchases required - receipts, invoices, etc.
Difference	\$ _____	Explain the intended disposition of balance Must be approved by the director of schools

Completed by: Cindi Morgan FBLA adviser 8-29-25
Sponsor's Name & Title Date

Reviewed by: _____ Principal/Bookkeeper _____ Date

Approved by: [Signature] 8/29/25
Principal/Director of Schools (if applicable) Date

DOUG LANE
2059 Lake Drive, Centerville, TN 37033

RONALD GAMMONS
6419 Rice Ln., Lyles, TN 37098

TIM HOBBS
9220 Old Bon Aqua Rd., Bon Aqua, TN 37025

TABITHA CUDE
4141 Lewis Rd., Centerville, TN 37033



John Mullins
Superintendent of Schools
115 MURPHREE AVENUE
CENTERVILLE, TN 37033

CHRISTY MAYS
450 Hwy 50, Centerville, TN 37033

SHERRI BAKER
9037 E 40 Rd., Bon Aqua, TN 37025

JANE HERRON
PO Box 13, Nunnally, TN 37137

School Support Organization Request For Fundraising Activities

Organization Agriculture / FFA

Proposed Fundraising Activity Annual Fruit Sale

Date(s) OCT 14 - 28 END NOV 5

Location(s) _____

Sherry Baker
Requested By Sherry Baker
President/Chair of Organization

9-29-25
Date

Robyn Emerson
Recommended By Robyn Emerson
Principal

9-29-25
Date

John Mullins
Approved John Mullins
Director of Schools or Designee

10-1-25
Date

Not Approved _____
Director of Schools or Designee

Date

**** A signed copy will be mailed to the organization and forwarded to the school****

PROPOSED FUNDRAISING ACTIVITIES

Fund/account name Volleyball - 601

Proposed fundraising activities: Tshirt/Sweatshirt sale

Purposed Uses of funds raised Team gear and post-season

Expected student involvement (school-wide or specific school organization) _____

School-Wide

Method by which school will receive profit Cash/check

Requested by Rachael Hudgins-Huntt - Head Coach Date 9-11-25
Name/Title

Approved by Robyn Emerson Date 9-11-25
Principal

Approved by John Mullins Date 9-12-25
Director of Schools*

* The Director of Schools must approve all fundraising activities that involve the participation of the general student population in the marketing process of the fundraising effort.

FUNDRAISER AUTHORIZATION FORM

School Hickman County High School

Fund/club/class account Golf Team

Expected timeframe of fundraiser Oct 13/2025

Proposed fundraising activities We are hosting a golf tournament

Method of fundraising (e.g., in-person, crowdfunding, etc.) Entry Fees/Donations

Proposed uses of funds raised* Purchasing Equipment + Paying tournament fees

Expected student involvement (school-wide or specific school organization)
Yes

Method by which school will receive profit _____

Requested by Chris Dawson/Coach Date 9/10/25
Name/Title

Approved by Reby Emerson Date 9-11-25
Principal

Approved by John Mullins Date 9-11-25
Director of Schools**

* Any change in proposed uses of funds raised must be approved by the Director of Schools

** The Director of Schools must approve all fundraising activities that involve the participation of the general student population in the marketing process of the fundraising effort.

FUNDRAISER AUTHORIZATION FORM

School HCHS

Fund/club/class account JAG TN - 847

Expected timeframe of fundraiser Sept. 15 May 29th

Proposed fundraising activities Fan Buttons for sporting Events

Method of fundraising (e.g., in-person, crowdfunding, etc.) in-person

Proposed uses of funds raised* Class supplies a JAG TN
+ JAG National competition

Expected student involvement (school-wide or specific school organization)
JAG TN students

Method by which school will receive profit Cash, Check

Requested by Cody A. Donohoe JAG Teacher Date 8-29-25
Name/Title

Approved by Robyn Emerson Date 8-29-25
Principal

Approved by John Mullins Date 9-4-25
Director of Schools**

* Any change in proposed uses of funds raised must be approved by the Director of Schools

** The Director of Schools must approve all fundraising activities that involve the participation of the general student population in the marketing process of the fundraising effort.



Tennessee School Boards Association
2025 Annual Convention Schedule
Gaylord Opryland Resort and Convention Center

Thursday, November 13

10:30 a.m.-6:30 p.m. Registration

12:30-1:45 p.m. Board Chairman Roundtable Discussion

Facilitator: Keys Fillauer

2:00-6:00 p.m.

Leadership Conference



Agenda Attached

Friday, November 14

7:00 a.m.-6:15 p.m. Registration

7:15-8:15 a.m. Leadership Conference Breakfast

8:30-11:30 a.m. Leadership Conference



Agenda Attached

11:30 a.m. Lunch (*on your own*)

11:30 a.m.-1:00 p.m. TSBA Tradeshow Welcome Reception

11:30 a.m.-4:00 p.m. TSBA Tradeshow Open

1:15-3:15 p.m. Pre-Convention Legal Workshop

1:15-3:15 p.m. Pre-Convention Advocacy Workshop

3:15-4:00 p.m. Networking Session

4:15-5:45 p.m. Opening General Session

Speaker: Jeff Henderson

Saturday, November 15

7:00 a.m.-5:00 p.m. Registration

7:00-10:30 a.m. TSBA Tradeshow Open

7:00-8:15 a.m. TSBA Tradeshow and Networking Session Breakfast

8:30-9:30 a.m. Clinic Session A

9:45-10:15 a.m. TSBA Tradeshow Door Prizes

10:30-11:30 a.m. Clinic Session B

11:45 a.m.-1:15 p.m. Awards Ceremony and Convention Luncheon

1:45-2:45 p.m. Clinic Session C

3:15-4:45 p.m. Delegate Assembly

3:15-4:45 p.m. Board Secretaries' Conference

Sunday, November 16

7:00-10:00 a.m. Registration
7:15-8:15 a.m. Convention Breakfast
8:30-9:45 a.m. Closing General Session
 Speaker: Dr. John Hodge
9:45 a.m. Adjourn

TSBA Leadership Conference
November 13-14, 2025
Gaylord Opryland Resort and Convention Center
AGENDA

November 13, 2025

2:00 p.m.	Welcome and Introductions	Jayson McDonald, TSBA President, White County
2:01 p.m.	Extreme Ownership: Combat Leadership for Business	Codey Gandy, Former U.S. Marine and Leadership Instructor, Echelon Front
3:30 p.m.	BREAK	
4:00 p.m.	Extreme Ownership: Combat Leadership for Business (Continued)	
5:55 p.m.	Announcements	Jayson McDonald
6:00 p.m.	Adjourn	

November 14, 2025

7:30-8:15 a.m.	Leadership Conference Breakfast	
8:30 a.m.	Welcome and Introductions	Jayson McDonald
8:31 a.m.	What My Generation Needs From You	Orion Jean, 2021 TIME Kid of the Year
9:30 a.m.	BREAK	
10:00 a.m.	Innovative Pathways for Student Success: A Step-by-Step Guide	Ben Torres, TSBA Assistant Executive Director/General Counsel Joe T. Wood, Education Consultant Gina Pavlovich, Ed. D., Executive Director of Advanced Placement Access for All, Niswonger Foundation Jillian Davis, Assistant Director of Niswonger Online, Niswonger Foundation Debra Bentley Ed. D., Director of Project On- Track, Niswonger Foundation Law Loving, Director of Career & Workforce Readiness, Niswonger Foundation Vicki Kirk, Ed. D., Director of STEM Learning Design, Niswonger Foundation
11:25 a.m.	Wrap Up	Jayson McDonald
11:30 a.m.	Adjourn	