



Saline County Board of Commissioners

Meeting Agenda

AGENDA

SALINE COUNTY BOARD OF COMMISSIONERS

SALINE COUNTY COURTHOUSE

Wilber, NE

9:30 AM

DATE: May 23, 2023

This agenda is kept on a daily basis and may change from day to day as requests come in to the County Clerk's office. Requests to be on the agenda must be in the County Clerk's office 24 hours prior to the start of the meeting as stated above. This agenda is considered current on the day of the meeting and cannot be changed or altered except for an emergency.

The Board reserves the right to go into executive session if such session is clearly necessary for the protection of the public interest or for the prevention of needless injury to the reputation of an individual.

ROLL CALL

APPROVAL OF AGENDA

APPROVAL OF MINUTES OF THE PREVIOUS MEETING

CITIZENS FORUM

CORRESPONDENCE

REPORT OF OFFICIALS

BUSINESS FOR ACTION

9:45 - Discussion/Update with Jerad Reimers, Community Liaison for Senator Adrian Smith

10:00 - Open/Review and possibly accept a Bid for Public Defender

10:30 - Chris Reece, Nebraska Drug Court - Discuss/Approve Interlocal Agreement and present budget request

10:45 - Patrick Kreifels, Regional Administrator at Region V - Services Update

Discuss/Approve the Blobaum & Busboom, P.C., acceptance and understanding to prepare a proposed budget and accompanying schedules for the year ended June 30, 2024.

Discuss/Approve Resolution #2023-26, to establish a petty cash fund for the Sheriff's Office

Discuss/Approve Resolution #2023-28 - Open Meetings Act - Establish a rule of three (3) minutes per person attending to speak.

Discuss/Approve - Electronic Contracting Company Inc., Milestone Care Plus Renewal beginning 07/01/2023 for the security cameras at the Courthouse and Law Enforcement Center, \$3,366.00.

Discuss/Approve installation of a security window in the Clerk's office, \$13,500.00

Approve/Disapprove a minor sub-division application at 34-5-1 (Lintz)

Approve/Disapprove minor sub-division application for 7-6-1 (Skrivanek)

Discuss/Approve - National Insurance Services, Life and Long-Term Disability, Madison National Life Insurance Company Renewal, Group #020406 - effective July 1, 2023

Discuss/Approve NACO VSP Vision Insurance Plan Renewal effective July 1, 2023

Discuss/Approve - NACO Blue Cross/Blue Shield Subgroup Application for Health Insurance effective July 1,2023

Discuss/Accept the County Clerk letter of retirement

Sheriff Alan Moore - Discussion regarding LEC water heater, Building and Grounds Budget for Law Enforcement Center

RESOLUTIONS TO TRANSFER FUNDS

Discuss/Approve - Resolution #2023-27, transferring \$298.22 from the Grant Fund to the General Fund, for the purpose of reimbursing the General Fund for Grant Retirement Contributions

Discuss/Approve - Resolution #2023-29 - transferring \$5,500.00 from the Inheritance Fund to the Juvenile Services Aid Program, to be reimbursed when funds become available.

HIGHWAY SUPERINTENDENT - ROAD AND BRIDGE MATTERS

Discuss and Approve/Disapprove Speece Lewis change order for C76(778).

CLAIMS APPROVAL

11:30 COUNTY GENERAL ASSISTANCE AND CLOSED SESSION MATTERS

Inmate Medical Discussion

ADJOURNMENT

SALINE COUNTY BOARD OF COMMISSIONERS

The regular meeting of the Saline County Board of Commissioners was called to order at 9:30 a.m. on Tuesday, May 9, 2023, by Chairperson Phil Hardenburger. Present were Hardenburger, Stephanie A. Krivohlavek, Marvin A. Kohout, Janet J. Henning, and Russ Karpisek Commissioners, County Clerk Anita K. Bartels and County Attorney David C. Solheim.

Notice of said meeting was posted in the County Clerk's Office and published in all three county newspapers on May 3, 2023, in compliance with State Statutes.

Hardenburger advised those present of the open meetings act posted at the back of the room and that all proceedings are electronically recorded.

Krivohlavek moved to approve the agenda as presented, seconded by Kohout. Voting aye were Karpisek, Kohout, Krivohlavek, Hardenburger and Henning, nays none, motion carried.

Henning moved to approve the minutes of the April 25, 2023 meeting, seconded by Karpisek. Voting aye were Kohout, Krivohlavek, Henning and Karpisek, abstain without conflict Hardenburger, nays none, motion carried.

Under Citizens Forum, Jack Sukovaty, Susan Novak Kotas, Lyle Weber read an email from Russell Korinek, Jeff Koll, Lester Ralston, Hannes Zetzsche and Chuck McKay addressed the Board.

Under Correspondence, Bartels reported receiving from the City of Crete notice of their May 2nd City Council and Council Committee meetings; an email inquiry regarding interest in coordinating a hazardous waste collection by Red Willow County Waste Department; a request from Dustin Will with Benefit Management to offer an evaluation of health & benefit programs and from EDF Renewables a donation of \$1,000.00 was received for the Employee Appreciation Dinner.

Karpisek reported contacting the Lincoln Lancaster County Health Department regarding recommendations for wind turbine dBA levels.

Under Report of Officials, County Assessor Brandi Kelly provided the Board an explanation of the Nebraska Tax Equalization and Review Commission, Finds and Order Adjusting. Kelly explained Valuation Group 2 affects Crete Residential and Group 5 affects Friend Residential putting these valuations within the middle range at 96% per State Statute.

Krivohlavek reported on meetings with the Aging Services full Board and the Insurance Committee.

Kohout reported on meetings with the Saline County Museum appraisal event, Employee Handbook Committee, Employee Recognition Committee, Planning & Zoning and Safety Committee.

Hardenburger reported on meetings with the Employee Handbook Committee, Insurance Committee, Ag Society, Extension Board, Drug Court Graduation and Hometown Housing USA.

Henning moved to approve the April 2023 Clerk Fees in the amount of \$10,765.50, seconded by Krivohlavek. Voting aye were Krivohlavek, Hardenburger, Henning, Karpisek and Kohout, nays none, motion carried.

Henning moved to approve the April 2023 Clerk of the District Court Fees in the amount of \$26,134.69, seconded by Karpisek. Voting aye were Hardenburger, Henning, Karpisek, Kohout and Krivohlavek, nays none, motion carried.

Henning moved to approve the April 2023 Sheriff Fees in the amount of \$2,799.05, seconded by Kohout. Voting aye were Henning, Karpisek, Kohout, Krivohlavek and Hardenburger, nays none, motion carried.

At 10:09 a.m. Hardenburger announced the Board would recess;

At 10:21 a.m. Hardenburger announced the Board would reconvene;

Discussion was opened on proposed Ordinance 2023-01. Solheim stated three (3) readings of an Ordinance is required before approval, unless 80% of the Board move to waive the three (3) reading requirement.

Krivohlavek moved to waive the three (3) reading requirement of Ordinance 2023-01, seconded by Kohout. Voting aye were Kohout, Krivohlavek, Hardenburger and Henning, nays Karpisek, motion carried.

Krivohlavek read aloud proposed Ordinance 2023-01. A copy of said ordinance is attached to these minutes as part of the permanent record.

Kohout moved to approve Ordinance 2023-01, seconded by Krivohlavek. Voting aye were Kohout, Krivohlavek and Hardenburger, nays Henning and Karpisek, motion carried.

Henning moved to approve Resolution #2023-24 transferring \$6,000.00 from the Inheritance Fund to the Juvenile Services Aid Program, to be reimbursed when funds become available, seconded by Karpisek. Voting aye were Krivohlavek, Hardenburger, Henning, Karpisek and Kohout, nays none, motion carried.

Bartels presented a request from Wayne M. Hansen Irrevocable Trust to occupy the right of way at NE4 29-8-3 to bore an electrical line. Henning moved to approve, seconded by Kohout. Voting aye were Hardenburger, Henning, Karpisek, Kohout and Krivohlavek, nays none, motion carried.

Bartels presented a request from Wayne M. Hansen Irrevocable Trust to occupy the right of way at SE4 29-8-3 to bore an electrical line. Krivohlavek moved to approve, seconded by Kohout. Voting aye were Henning, Karpisek, Kohout, Krivohlavek and Hardenburger, nays none, motion carried.

Bartels presented a request from Windstream to occupy the right of way for Project C76(821), WO #71503003000041; PR-14190, located east of Road 2350 on OO Road. Krivohlavek moved to approve, seconded by Karpisek. Voting aye were Karpisek, Kohout, Krivohlavek, Hardenburger and Henning, nays none, motion carried.

Henning moved to approve the claims as presented, seconded by Krivohlavek. Voting aye were Kohout, Krivohlavek, Hardenburger, Henning and Karpisek, nays none, motion carried.

Rebecca Anderson	Atty Fees	332.50
Associated Psychologists	Cntrct	1,364.50
Barnas	Spls	1,066.98
Johnny Barta	P&Z	33.34
Black Hills	Utly	2,644.41
Blue Valley Door	Bldg Maint	165.00
Gerald Brown	P&Z	29.41
Brown's Tree	Bldg Maint	2,100.00
Capital Business	Cntrct	166.00
City of Wilber	Utly	9,411.40
Clerk of the Supreme Court	Fees	178.00
CAMC	Cntrct	82.97
Culligan	Cntrct	191.50
Cummins	Equip Rpr	461.19
Eakes	Ofc Spls	5,124.47
Ecolab	Spls	512.15
Equifax	Cntrct	198.93
Eric Escobar-Barrera	Reimb	225.25
Fairfield Inn	Trng	659.70
Farmers Coop	Fuel	137.83
Ronald Fink	P&Z	29.41
First Concord	Ins	14,392.82
First Concord	Ins	72.50
Flagz @ the Brand	Spls	859.00
Food Mesto	Spls	11.97
Friend Comm Hlthcr	Cntrct	430.00
Galls	Unif	139.98
Grunwald Mech	Cntrct	1,035.00
Philip Hardenburger	Milg	49.78
David Hermsmeier	P&Z	16.31
Holiday Inn	Trng	392.00
The Home Depot Pro	Spls	340.87
Jefferson Co Em Mgmt	Cntrct	4,350.00
Jindra Irrigation	Bldg Maint	175.00
Kiner Supply	Spls	109.38
Marvin Kohout	Reimb	4,190.00
Jeffrey Koll	P&Z	29.41
Kuncl	Trnspt	450.00
Lincoln Radiology	Hlth	266.22
Mallory Safety	Spls	1,590.77

Microfilm Imaging	Cntrct	150.00
MIPS	Cntrct	2,425.09
Nathan Mueller	Milg	152.62
Amber Mulbery	Milg	18.34
Keith Muller	P&Z	19.59
Joseph Murray	Atty Fees	12,294.00
NACO	Cntrct	2,243.62
NE Health Lab	Cntrct	105.00
NPPD	Utly	237.00
Planet Tech	Comm	7,138.56
Police Ofcr Assn of NE	Spls	24.00
Protex	Spls	42.00
Reeves	Unif	33.43
Riverside	Equip Rpr	59.13
Sack Lumber	Spls	463.05
Saline Center	Rent	250.00
Saline Co Crt	Reimb	412.00
Saline Co Dist Crt	Reimb	216.00
Saline Co Sheriff	Reimb	639.25
Sapp Bros	Fuel	6,271.55
Seward Co Ind	P&P	187.82
Soarin Grp	Cntrct	4,296.97
Debbie Spanyers	Milg	51.09
Anita Stougard	Milg	72.71
Summit	Spls	9,917.58
Timekeeping Sys	Cntrct	395.00
Tyler Tech	P&P	449.00
Unite	Comm	6,405.86
UNL	Reimb	6,480.55
Us Bank	Cntrct	354.74
Verizon	Comm	2,440.65
Visa	Trng	44.07
Visa	Unif	62.92
Walker	Spls	72.82
Walker	Spls	78.83
Joel Weber	P&Z	41.86
Mary Jo Weber	P&Z	62.16
Witness Fees	Jury Duty	4,402.27
41 Auto	Spls	53.52
Beatrice Concrete	Gravel	40,096.84
Beaver Hardware	Spls	174.44
Black Hills	Utly	948.83
BNSF	Cntrct	851.21
City of Crete	Utly	289.72
City of Wilber	Utly	70.68
Crete Glass	Spls	36.00
Cummins	Spls	10.00
Deere Credit	Equip Rpr	9,970.61
Exeter Lumber	Spls	53.50
Farmers Coop	Fuel	28,472.32
Johnson Sand & Gravel	Gravel	10,712.06
Linde Gas	Spls	91.57
NE IA Ind	Spls	545.00
NMC	Equip Rpr	981.86
Powerplan	Equip Rpr	21,335.30
RDO	Spls	40.38
Sapp Bros	Fuel	3,432.62

Speece-Lewis	Eng Fees	6,540.00
The Fort	Unif	1,038.85
Village of Dewitt	Utly	86.44
Village of Dorchester	Utly	106.25
Village of Tobias	Utly	57.60
Village of Western	Utly	83.25
Waste Connections	Utly	236.78
41 Auto	Spls	157.55
Kathy Homolka	Milg	168.99
Dewitt American Legion	Reimb	1,349.80
Wilber Czech Museum	Reimb	1,200.00
Jessica Acosta	Prgm	920.00
Samantha Cosaert	Prgm	570.00
Dewitt Senior Center	Prgm	233.10
Eakes	Ofc Spls	265.10
Food Mesto	Prgm	60.19
Delaney Mazza	Prgm	168.00
Public Health Solutions	Prgm	52.50
Seward County Independent	P&P	6.98
Donna Zlab-Kovar	Milg	34.06
Redwood Toxicology Laboratory Inc	Cntrct	70.00
Family Service Lincoln	Cntrct	4,837.60
Anita Stougard	Reimb	1,250.50
Verizon	Comm	42.75
Kiesler's	Equip	20,190.75
Barnas	Spls	1,126.78
Bob Barker Co	Spls	113.49
Charm-Tex	Spls	575.50
Eakes	Spls	1,208.53
Summit	Spls	6,262.58
Visa	Spls	291.82
41 Auto	Spls	555.26
	Payroll &	
iSolved Payroll, Taxes & Payments	Taxes	229,314.56
Ameritas Life	Retire	27,362.08
BC/BS	Hlth Ins	
Principal Dental	Dental Ins	2,148.97
Madison Nat'l Life	Life Ins	57.84
AFLAC	Ins	1,058.43
VSP	Eye Ins	488.21
Empower	Def Comp	2,192.00
First Concord	Café	1,638.12
Colonial Supp Ins	Ins	164.87
Madison Nat'l Life	Dis Ins	196.41
Teamsters	Dues	297.00
New York Life	Ins	95.64
Globe Life	Ins	213.64
Saline County Court	Garnish	605.42
Bruce Wingerd	Garnish	512.74

At 10:52 a.m. Henning moved to enter closed session to discuss a personnel issue, seconded by Karpisek. Voting aye were Krivohlavek, Hardenburger, Henning, Karpisek and Kohout, nays none, motion carried.

At 11:17 a.m. Henning moved to exit closed session, seconded by Karpisek. Voting aye were Hardenburger, Henning, Karpisek, Kohout and Krivohlavek, nays none, motion carried.

Hardenburger stated during closed session a personnel issue was discussed with no action taken.

There being no further business to come before the Board, the meeting was adjourned at 11:18 a.m. The next regular meeting will be on Tuesday, May 23, 2023 at 9:30 a.m. in the Saline County Commissioners' Room, Court House, Wilber, NE.

ATTEST:

Anita K. Bartels, County Clerk

Janet J. Henning

Stephanie A. Krivohlavek, Vice-Chairperson

Marvin A. Kohout

Phil Hardenburger, Chairperson

Russ Karpisek

I, Anita K. Bartels, County Clerk in and for Saline County, do hereby certify that the minutes of the previous meeting held on April 25, 2023 were approved as presented.

Anita K. Bartels, County Clerk

Janet J. Henning

Stephanie A. Krivohlavek, Vice-Chairperson

Marvin A. Kohout

Phil Hardenburger, Chairperson

Russ Karpisek

Budget for Southeast Nebraska Adult Drug Court 2023-2024				
				Expenses
Supplies	Incentives			\$750.00
	Office Supplies			\$500.00
	Printing Fees			\$300.00
	Data Processing Equipment			\$800.00
Training	Training Mileage			\$1,500.00
	Training Fees/Supplies			\$500.00
	Training Meal Allowance			\$600.00
Contracted Services	Public Defender			\$14,400.00
	Mileage			\$3,000.00
	Drug Testing			\$2,000.00
	Total Requested Budget to be Adopted			\$24,350.00
	Carryover from 2022-2023 Budget			\$7,500.00
	Total Amount Requested from Counties for 2023-2024			\$16,850.00

County	Participants in 2022	% of Population	Assessment	Cost
Fillmore County	2	6%	\$1,000	\$711.00
Gage County	24	70%	\$1,000	\$8,295.00
Jefferson County	3	9%	\$1,000	\$1,066.50
Saline County	4	12%	\$1,000	\$1,422.00
Thayer County	1	3%	\$1,000	\$355.50
Totals	34	100.00%	\$5,000	\$11,850.00

County Total Owed
\$1,711.00
\$9,295.00
\$2,066.50
\$2,422.00
\$1,355.50
\$16,850.00

Southeast Nebraska Adult Drug Court **Interlocal Agreement 2023-2024** **Saline, Jefferson, Thayer, Fillmore** **and Gage Counties**

This Interlocal Agreement is made and entered into among the Counties of Saline, Jefferson, Thayer, Fillmore and Gage in Nebraska, political subdivisions of the State of Nebraska, hereinafter referred to as the “Counties”.

WHEREAS, the Interlocal Cooperation Act, Neb. Rev. Stat. § 13-801 et seq., provides that unit of local government of the State of Nebraska may enter into an agreement for the joint and cooperative exercise of powers, privileges, or authority capable of being exercised by either agency; **and**

WHEREAS, Neb. Rev. Stat. § 13-807, et. seq., (Reissue 1997) provides that one or more public agencies may contract with any one or more other public agencies to perform any governmental service, activity, or other undertaking which each public agency entering into the contract is authorized by law to perform; **and**

WHEREAS, the Counties are public entities as defined by Neb. Rev. Stat. § 13-803; **and**

WHEREAS, the Counties’ intention in contracting for such services is to reduce recidivism, redirect participants out of the court system and costs associated by establishing a problem solving court for the Counties, herein referred to as the Southeast Nebraska Adult Drug Court; **and**

WHEREAS, the Counties are willing to perform this service in consideration of certain amounts to be paid and established pursuant to the terms of this Agreement, **and**

NOW, THEREFORE, in consideration of the mutual covenants contained herein, it is agreed between the parties as follows:

The term of this Agreement is July 1, 2023, through June 30, 2024:

1. The expenses incident to the conduct and maintenance of the Problem- Solving Court shall in the first instance be paid by Saline County, which shall act as the fiscal agent.
2. Each county shall provide office space and necessary facilities for Problem-Solving Court staff performing their official duties and shall bear the costs incident to maintenance of such offices.

3. The Problem-Solving Court shall operate as a "probation based" problem solving court and shall adhere to the Nebraska Supreme Court rules governing establishment and operation of problem solving courts.
4. Each county shall contribute to the operation of the Problem-Solving Court as shown on Exhibit A.
5. Saline County will provide courtroom security services. The prosecuting attorney for the drug court hearings will be paid by a contracted fee as indicated in attachment A. Each county will be responsible for housing its own prisoners.
6. The Counties may provide in-kind services as agreed between the parties and be reimbursed for the costs of said services they provided based upon Exhibit A.
7. In the event grant funds or similar funds are obtained for the Problem- Solving Court, the same shall be applied to defray expense of the Problem-Solving Court as authorized by such funding and to the extent possible shall be applied to the expenses of the counties on a pro rata basis.
8. Collaboration, cooperation and communication are expected between all participating parties.
9. All parties acknowledge the possibility of future reductions in County appropriations. The Counties do not guarantee the continued availability of funding for this agreement notwithstanding the consideration stated above. In the event funds to finance this agreement become unavailable either in full or in part due to such reductions in appropriations the parties may terminate this agreement or reduce the consideration upon notice in writing to the others. The effective date of such termination or reduction in consideration shall be the actual effective date of the elimination or reduction of appropriations. In the event of a reduction in consideration, the parties may cancel this agreement as of the effective date of the proposed reduction upon the provision of advance written notice to the others.
10. This Agreement shall supersede any and all previous agreements between the parties regarding the subject matter covered herein, and any previous agreements are hereby terminated by agreement of the parties.

EXECUTED this _____ day of _____, 2023 by FILLMORE County.

Chair
FILLMORE County Board of Commissioners

EXECUTED this _____ day of _____, 2023 by GAGE County.

Chair
GAGE County Board of Commissioners

EXECUTED this _____ day of _____, 2023 by JEFFERSON County.

Chair
JEFFERSON County Board of Commissioners

EXECUTED on this _____ day of _____, 2023 by SALINE County.

Chair
SALINE County Board of Commissioners

EXECUTED this _____ day of _____, 2023 by THAYER County.

Chair
THAYER County Board of Commissioners

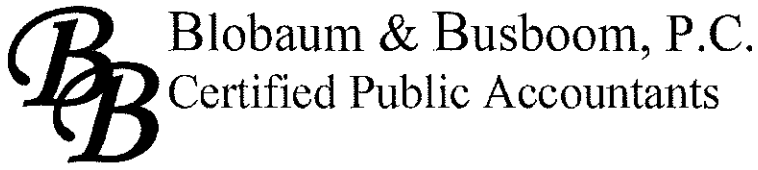

Blobaum & Busboom, P.C.

Certified Public Accountants

Brian L. Blobaum, CPA
Jennifer M. Busboom, CPA
Michael A. Blobaum, CPA

410 4th Street, P.O. Box 604 • Fairbury, NE 68352 • Phone: (402) 729-6136 • Fax: (402) 729-6157 • Email: bbcpas@windstream.net
Hebron Branch Office: 120 South 4th Street • Hebron, NE 68370 • Phone: (402) 768-6485

May 9, 2023

PLEASE SIGN AND RETURN TO US

Saline County
Saline County Commissioners
P.O. Box 865
Wilber, NE 68465

Dear Commissioners:

We are pleased to confirm our acceptance and our understanding of the services we are to provide for Saline County Commissioners.

You have requested that we prepare the forecast of Saline County Commissioners, which comprises the proposed budget information and accompanying schedules for the year ended June 30, 2024, and the related summaries of significant assumptions (forecast), in the form prescribed by the State of Nebraska Auditor of Public Accounts, and perform a compilation engagement with respect to the forecast. The forecast will not include a summary of significant accounting policies or other required disclosures not related to the significant assumptions.

A forecast presents, to the best of management's knowledge and belief, Saline County Commissioners's expected financial position, results of operations, and cash flows for the forecast period. It is based on management's assumptions reflecting conditions it expects to exist and the course of action it expects to take during the forecast period.

Our Responsibilities

The objective of our engagement is to –

1. prepare the forecast in accordance with the format prescribed by the State of Nebraska Auditor of Public Accounts based on information provided by you, and
2. apply accounting and financial reporting expertise to assist you in the presentation of the forecast without undertaking to obtain or provide any assurance that there are no material modifications that should be made to the forecast in order for it to be in accordance with the format prescribed by the State of Nebraska Auditor of Public Accounts.

We will conduct our compilation engagement in accordance with Statements on Standards for Accounting and Review Services (SSARS) promulgated by the Accounting and Review Services Committee of the AICPA and comply with the AICPA's *Code of Professional Conduct*, including the ethical principles of integrity, objectivity, professional competence, and due care.

We are not required to, and will not, verify the accuracy or completeness of the information you will provide to us for the engagement or otherwise gather evidence for the purpose of expressing an opinion or a conclusion. Accordingly, we will not express an opinion or a conclusion nor provide any assurance on the forecast.

Our engagement cannot be relied upon to identify or disclose any misstatements in the forecast, including those caused by fraud or error, or to identify or disclose any wrongdoing within the entity or noncompliance with laws and regulations.

We, in our sole professional judgement, reserve the right to refuse to perform any procedure or take any action that could be construed as assuming management responsibilities.

Your Responsibilities

The engagement to be performed is conducted on the basis that you acknowledge and understand that our role is to prepare the forecast in accordance with the format prescribed by State of Nebraska Auditor of Public Accounts and assist you in the presentation of the forecast in accordance with the format prescribed by the State of Nebraska Auditor of Public Accounts. You have the following overall responsibilities that are fundamental to our undertaking the engagement in accordance with SSARS:

1. The selection of the format prescribed by State of Nebraska Auditor of Public Accounts and the cash basis as the financial reporting framework to be applied in the preparation of the forecast.
2. The preparation and presentation of the forecast in accordance with the format prescribed by the State of Nebraska Auditor of Public Accounts, including the disclosure of significant assumptions.
3. The design, implementation, and maintenance of internal control relevant to the preparation and presentation of the forecast that is free from material misstatement whether due to fraud or error.
4. The prevention and detection of fraud.
5. To ensure that the Saline County complies with the laws and regulations applicable to its activities.
6. The accuracy and completeness of the records, documents, explanations, and other information, including significant judgements, you provide to us for the engagement.
7. To provide us with –
 - access to all information of which you are aware is relevant to the preparation and presentation of the forecast, such as records, documentation, and other matters.
 - additional information that we may request from you for the purpose of the compilation engagement.
 - unrestricted access to persons within the entity of whom we determine it necessary to make inquiries.

You are also responsible for all management decisions and responsibilities and for designating an individual with suitable skills, knowledge, and experience to oversee our preparation of your forecast. You are responsible for evaluating the adequacy and results of the services performed and accepting responsibility for such services.

Our Report

As part of our engagement, we will issue a report that will state that we did not examine or review the forecast and that, accordingly, we do not express an opinion, a conclusion, nor provide any assurance on it. It will also state that (1) the forecasted results may not be achieved as there will usually be differences between the forecasted and actual results because events and circumstances frequently do not occur as expected, and these differences may be material; and (2) we have no responsibility to update the report for events and circumstances occurring after the date of the report.

Our report will disclose that Saline County's management has elected to omit substantially all of the disclosures required by guidelines for presentation of a forecast established by the AICPA. If the omitted disclosures were to be included in the forecast, they might influence the user's conclusions about the Village's proposed budget information and accompanying schedules. Accordingly, the forecast is not designed for those who are not informed about such matters. There may be circumstances in which the report differs from the expected form and content.

You agree to include our compilation report in any document containing the forecast that indicates we have performed a compilation engagement on the forecast and, prior to inclusion of the report, to ask our permission to do so.

Other Relevant Information

Brian L. Blobaum is the engagement partner and is responsible for supervising the engagement and signing the report or authorizing another individual to sign it.

We estimate that our fees for these services will be \$7,350. The fee estimate is based on anticipated cooperation from your personnel and the assumption that unexpected circumstances will not be encountered during the engagement. If significant additional time is necessary, we will discuss it with you and arrive at a new fee estimate before we incur the additional costs.

You acknowledge that as a condition of our agreement to perform a compilation, you agree to the best of your knowledge and belief to be truthful, accurate, and complete in the representations you make to us during the course of the compilation. You agree to hold us harmless and to release, indemnify, and defend us from any liability or costs, including attorney's fees, resulting from management's knowing misrepresentations to us.

We appreciate the opportunity to be of service to you and believe this letter accurately summarizes the significant terms of our engagement. If you have any questions, please let us know. If you acknowledge and agree with the terms of our engagement as described in this letter, please sign the enclosed copy and return it to us.

Very truly yours,



Brian L. Blobaum, CPA

Accepted:

By: _____

Title: _____

Date: _____

RESOLUTION #2023-26

BE IT HEREBY RESOLVED, by the Board of Commissioners of Saline County, NE, to authorize a petty cash fund for the Sheriff/Law Enforcement Office as recommended by the office of the Nebraska Auditor of Public Accounts.

This Special Projects petty cash fund, is not to exceed \$10,000.00. Any balance over \$10,000.00 is to be submitted to the Saline County Treasurer.

Claims are to be submitted to the County Clerk's office, with receipts to replenish said petty cash fund.

Motion made by Commissioner _____, seconded by Commissioner _____, to adopt the foregoing Resolution. All members present voting as follows:

Yeas: _____

Nays: _____

Abstentions: _____

Absent: _____

Chairman

SUBSCRIBED AND SWORN TO before me this 23rd day of May 2023.

SEAL

Saline County Clerk

RESOLUTION #2023-28

In compliance with Neb. Rev. Stat. §84-1407. Act, how cited.

Sections 84-1407 to 84-1414 shall be known and may be cited as the Open Meetings Act.

Section 84-1412 sets out the rights of members of the public attending a meeting of a public body.

Saline County, Nebraska, has posted a current copy of the Open Meetings Act in the meeting room at a location accessible to the public. At the beginning of the meeting, the public shall be informed about the location of the posted information.

Members of the public have the right to attend and the right to speak at meetings of public bodies, and all or any part of the public meetings, except closed sessions, may be videotaped, recorded, televised, broadcast, or photographed by any person in attendance.

Public bodies may make and enforce reasonable rules and regulations regarding the conduct of persons attending, speaking at, videotaping, televising, recording, etc. their meetings, including meetings held by video conferencing.

Therefore a rule of three (3) minutes per person attending to speak is hereby established.

LB 83 amended §84-1412(3) to provide that public bodies shall require any person desiring to address the public body to identify themselves, and provide an address and the name of any organization represented by such person unless the address requirement is waived to protect the security of the individual.

Motion made by Commissioner _____, seconded by Commissioner

_____, to adopt the foregoing Resolution. All members present voting as follows:

Ayes: _____

Nays: _____

Absent: _____

Abstentions: _____

Saline County Board of Commissioners

Chairperson

SUBSCRIBED AND SWORN TO before me on this 23rd day of May, 2023.

SEAL

Saline County Clerk

Terms & Conditions

THESE BUSINESS TERMS (these Terms) are the general terms and conditions under which ECC will provide services to Client (the Services) under the Proposal to which they are attached (the Agreement). To the extent any purchase order contains any terms that are inconsistent with these Terms, those inconsistent terms are rejected by ECC.

- 1) **Independent Contractors.** ECC's relationship with Client will be that of an independent contractor, and nothing in the Agreement should be construed as creating a partnership, joint venture, or employer-employee relationship. ECC will have sole discretion to determine the manner, method, and means of performing the Services.
- 2) **Payment.** ECC shall receive payment for the Services as provided in the Agreement. Unless otherwise provided in the Agreement, invoices will be issued upon completion of the Services. All amounts payable under the Agreement are exclusive of sales, use, VAT, customs duties, excise, and any other applicable transaction taxes unless otherwise stated in the proposal. Except as otherwise required by the Agreement, Client shall make payment on invoices within thirty (30) days after issuance. If payment of any amount due under the Agreement is not received when due, interest shall begin to accrue and be payable at the lesser of the maximum rate permitted under applicable law or at the rate of six percent (6.0%) per month from the date due until paid in full. Client's obligation to pay all amounts due under the Agreement is absolute and unconditional, and Client is not entitled to any setoffs to such amounts.
- 3) **Warranties.** ECC MAKES NO WARRANTY OF MERCHANTABILITY OR FITNESS FOR A PARTICULAR PURPOSE. THE WARRANTIES MADE IN THESE TERMS ARE EXPRESSLY IN LIEU OF ANY OTHER WARRANTIES, EXPRESSED OR IMPLIED, AND ANY OTHER OBLIGATIONS OR LIABILITIES ON THE PART OF ECC, WHICH NEITHER ASSUMES NOR AUTHORIZES ANY OTHER PERSON TO ASSUME FOR IT ANY OTHER LIABILITY IN CONNECTION WITH THE SERVICES.
- 4) **Intellectual Property Rights.** Client acknowledges and agrees that ECC is the owner of, or holds license to, all right, title, and interest, including copyright and all other intellectual property rights, in and to any and all written materials, documents, flow charts, logic diagrams, source code, test materials, or other information relating to any intellectual property generated in providing the Services (collectively the "Work Product"). No transfer of ownership of any Work Product is intended by the Agreement, and Client agrees that it may not, and may not encourage any third party to, attempt to derive the source code or reverse engineer the Work Product.
- 5) **Non-Solicitation.** Client acknowledges that ECC has invested in the training and development of ECC's employees and that ECC's employees are one of its most valuable assets. Accordingly, during the term of providing Services and for one (1) year thereafter, Client shall not solicit for employment any employees of ECC or its affiliates who: (a) directly performed under the Agreement, (b) had substantial contact with Client in relation to the Agreement, or (c) Client became aware of due to, or derived from information learned through the performance of, the Agreement. For this purpose, "solicitation" does not include contact resulting from indirect means such as public advertisement, placement firm searches, or similar means not directed specifically at the employee to which the employee responds on his or her own initiative.
- 6) **Allocation of Risk.**
 - a) **Indemnification.** Client will indemnify and hold harmless ECC from all claims, liabilities, or expenses for damage to real property or tangible personal property, bodily injury, including death, and any other losses or damages arising out of the conduct of Client or its employees or agents.
 - b) **Limitation of Liability.** ECC'S LIABILITY FOR DAMAGES ARISING OUT OF OR RELATING TO THE AGREEMENT IS LIMITED TO THE FEES PAID BY CLIENT FOR THE SERVICES PROVIDED UNDER THE AGREEMENT FOR THE PERIOD OF ONE (1) YEAR PRIOR TO THE EVENT GIVING RISE TO LIABILITY. ECC SHALL NOT HAVE ANY LIABILITY WHATSOEVER TO CLIENT OR TO ANY THIRD PARTY FOR ANY LOSS OF PROFITS, OTHER CONSEQUENTIAL DAMAGES OR INCONVENIENCE DUE TO EARLY TERMINATION OF THE AGREEMENT, OR ANY THEFT, DAMAGE, LOSS OF DATA, OR DELAY, EVEN IF CLIENT HAS BEEN ADVISED OF THE POSSIBILITY OF SUCH DAMAGES.
 - c) **Attorney Fees.** Client agrees to reimburse ECC and any of its owners, employees, and agents for any attorney fees, costs, and expenses incurred: (a) successfully enforcing any part of the Agreement; or (b) successfully defending all or part of any state or federal court lawsuit that Client may file against ECC and/or any individual in their capacity as an owner, employee, or agent of ECC.
- 7) **Termination.** The Agreement may be terminated by either party if the other party has materially breached the Agreement and has failed to cure such breach within thirty (30) days after receipt of written notice thereof. Upon termination of the Agreement as set forth above, ECC may terminate any and all licenses granted to Client under the Agreement. Furthermore, upon termination of the Agreement for any reason, Client shall pay to ECC within five (5) days of receipt of a final invoice all fees due under the Agreement.
- 8) **Miscellaneous.**
 - a) **Enforceability.** The invalidity or unenforceability of any particular provision of these Terms will not affect the Agreement's other provisions, which are then to be applied as if the invalid or unenforceable provision were omitted.
 - b) **Integrated Agreement.** Except for any purchase orders issued hereunder, there are no agreements, understandings, restrictions, warranties, or representations on which Client may rely relating to providing the Services. Furthermore, no future agreements, understandings, restrictions, warranties or representations may be relied upon by Client unless they are set forth in writing by an authorized representative of ECC.
 - c) **Assignment.** Client may not assign or transfer any of its rights or obligations under the Agreement without the prior written consent of ECC. Any permitted assignee, successor, or purchaser shall expressly assume in writing the obligation to perform in accordance with the terms and conditions of the Agreement, and no assignment or transfer shall relieve ECC or Client of its previously accrued obligations under the Agreement.
- 9) **Acceptance of Agreement -** This agreement includes equipment and services that are required to satisfy the project scope of Section 1.0
- 10) **Scope of Work/Responsibilities.** ECC will begin work on this project upon receipt of a copy of this agreement duly signed and executed by an agent of the Customer, specifically authorized to bind the Customer to the terms and conditions of this agreement.

Due to global semiconductor chip shortages, Integrator is experiencing longer than normal lead times on equipment. As a result, Integrator cannot guarantee lead times on equipment and will not be liable for any delays in equipment delivery to the extent caused by such shortages. However, Integrator is working with its global suppliers on a daily basis to understand the impact of this chip shortage on delivery timelines and will use reasonable efforts to keep Buyer apprised of anticipated delivery timelines and delays.

This Electronic Contracting Company (ECC) proposal is subject to a Force Majeure clause for a pandemic (e.g. Covid-19) as declared by the World Health Organization (WHO) and the corresponding governmental orders and/or regulations. This clause applies as it relates to ECC's inability to perform its contract obligations based on the unforeseeable events that may have a future impact on our labor force, the timely delivery of materials, and the escalation of the cost of said materials. ECC will keep you apprised if this situation develops and all parties to this proposal will be contacted. ECC does welcome the opportunity to work together to develop risk avoidance and mitigation strategies with you and all other parties involved (e.g. Owner, General Contractor, Architects, Engineers, etc.)

QUOTATION: 43214

Subtotal: \$3,366.00
Tax: 0.00
Total: \$3,366.00

IF YOU WISH TO ACCEPT THIS PROPOSAL AND RELATED STATEMENT OF WORK, PLEASE SIGN AND RETURN

BUYER: Phil Hardenburger
(Print Name)

BUYER SIGNATURE: _____

DATE: May 23, 2023

SALES REP: Heather Dwinell
(Print Name)

SALES REP SIGNATURE: Heather Dwinell

DATE: _____

As acknowledgement that each page of the quotation was reviewed, please initial the bottom of each page.

**The Braxter Construction Group
402-890-1459
PO BOX 82023
Lincoln, NE 68501-2023**

Submitted To:

Mar-28-23

Saline County
204 S. High Street
Wilber NE 68465
ATTN: Project Manager

Phone: 402-821-2374
Fax: 0

PROJECT: Counter Glass Window Wall install

Drawing Date: 12/15/2022
Bid Date: asap
Addendum No: none

Architect: N/A

Price Includes material, equipment and labor to preform the following:

- ... Demo existing wall
- ... Remove existing wall conditions
- ... Frame Rough Opening for new window access
- ... Install window access
- ... Return wall to original condition

TOTAL AMOUNT FOR THIS WORK: \$13,500.00

This proposal does not include:

- ... Site access for equipment & materials
- ... Special Testing and Inspection
- ... Temp. Heat
- ... Weather protection
- ... Water Supply
- ... Hoisting for other trades
- ... Caulking
- ... Engineering
- ... Liquidated Damages
- ... Retainage
- ... Caulk in Blocks

T1-2436 BR
NEW GENERATION

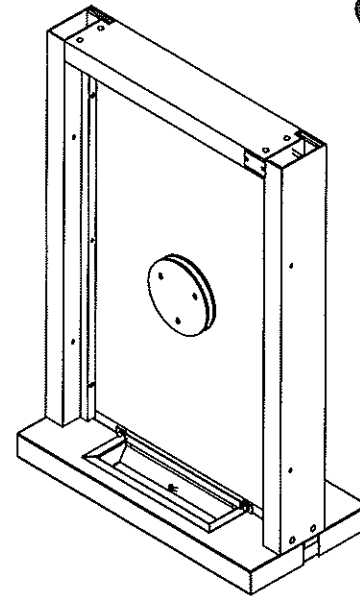
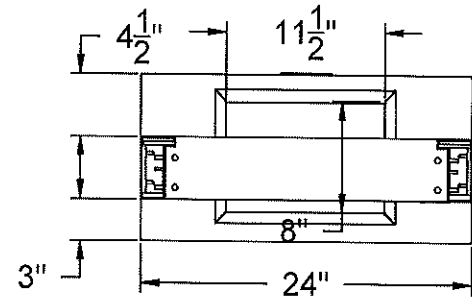

- PLEASE SELECT:**
- 1. FRAMING:**
 Aluminum Loaded Frame
 UL Rated Stainless
- 2. FRAME COLOR:**
 Bronze Anodized Clear Anodized
 Other: _____
- 3. GLAZING:**
 1/4" Tempered 1" Insulated
 3/4" Poly - L1 1" Insulated + Low-E
 1-1/4" Poly - L3 1-1/4" Acrylic - L1
 Storm Impact 1-1/4" Acrylic - L3
 Other: _____
- 4. DEAL TRAY TYPE:**
 Non-BR - Curved BR - Square
- 5. SPEAKER:**
 6" BR Speak-Thru (L3)
 5" Non-BR Speak Plate
 SC-100 Amplified SC-100L Amplified
 Speak Around

INTERIOR

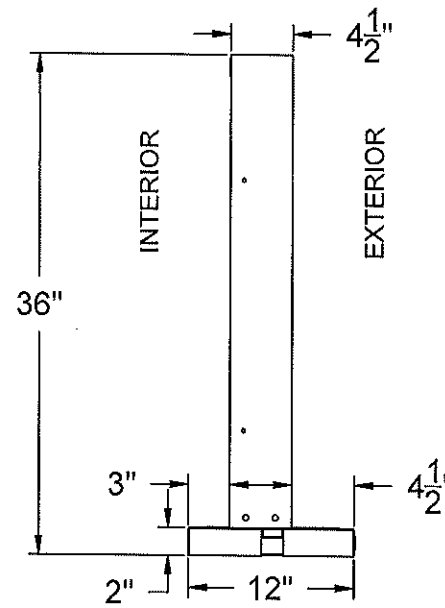
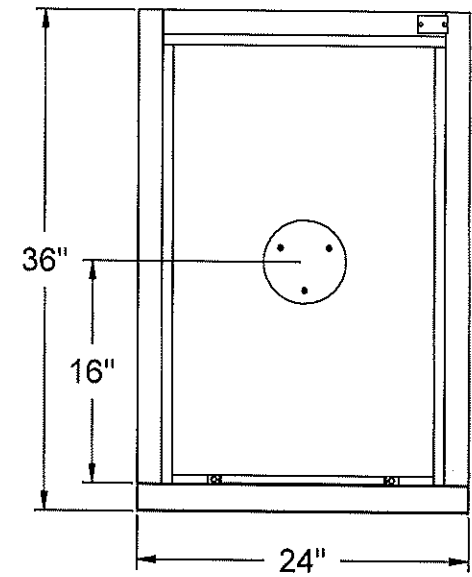

Key Notes

Unit:
T1-2436 BR NEW GENERATION

Actual Dimension:
24"(W) x 36"(H)

Rough Opening:
24-3/8"(W) x 36-3/8"(H)

Service Opening:
N/A

Engineer Notes

Date drawn: 11/4/2022 11:55 AM
 Drawn by: SCOONROD
 File name:
 T1-2436_BR_LD New Model Loaded.dwg
 Page: _____ Scale: NTS

NOTE: THIS DRAWING EMBODIES A CONFIDENTIAL PROPRIETY DESIGN ORIGINATED AND OWNED BY QUIKSERV CORP., AND IS SUBMITTED UNDER A CONFIDENTIAL RELATIONS ALL PATENT, MANUFACTURING, SALE RIGHTS REGARDING THE SAME ARE RESERVED EXCEPT TO THE EXTENT RIGHTS ARE EXPRESSLY GRANTED TO OTHERS. THE RECIPIENT AGREES BY ACCEPTING THESE DRAWINGS NOT TO SUPPLY OR DISCLOSE ANY INFORMATION REGARDING THEM TO ANY UNAUTHORIZED PERSONAL.

SIGNATURE: _____
 DATE: _____

T1-2436 BR
NEW GENERATION

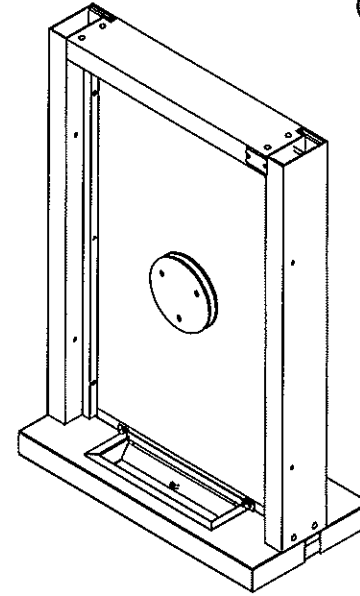
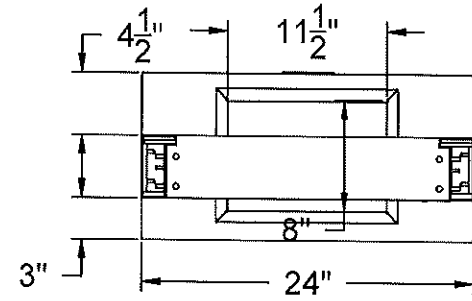

- PLEASE SELECT:**
- 1. FRAMING:**
 Aluminum Loaded Frame
 UL Rated Stainless
- 2. FRAME COLOR:**
 Bronze Anodized Clear Anodized
 Other: _____
- 3. GLAZING:**
 1/4" Tempered 1" Insulated
 3/4" Poly - L1 1" Insulated + Low-E
 1-1/4" Poly - L3 1-1/4" Acrylic - L1
 Storm Impact 1-1/4" Acrylic - L3
 Other: _____
- 4. DEAL TRAY TYPE:**
 Non-BR - Curved BR - Square
- 5. SPEAKER:**
 6" BR Speak-Thru (L3)
 5" Non-BR Speak Plate
 SC-100 Amplified SC-100L Amplified
 Speak Around

INTERIOR

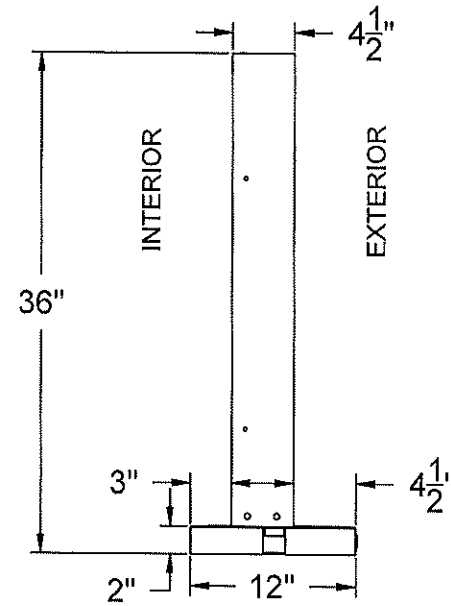
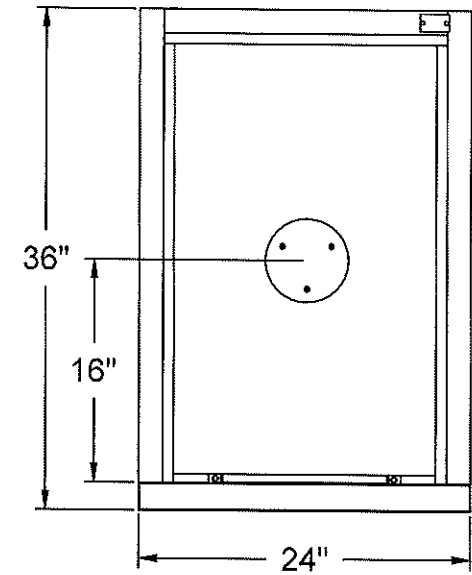

Key Notes

Unit:
T1-2436 BR NEW GENERATION

Actual Dimension:
24"(W) x 36"(H)

Rough Opening:
24-3/8"(W) x 36-3/8"(H)

Service Opening:
N/A

Engineer Notes

Date drawn: 11/4/2022 11:55 AM
 Drawn by: SCOONROD
 File name:
 T1-2436_BR_LD New Model Loaded.dwg
 Page: _____ Scale: NTS

NOTE: THIS DRAWING EMBODIES A CONFIDENTIAL PROPRIETY DESIGN ORIGINATED AND OWNED BY QUIKSERV CORP., AND IS SUBMITTED UNDER A CONFIDENTIAL RELATIONS ALL PATENT, MANUFACTURING, SALE RIGHTS REGARDING THE SAME ARE RESERVED EXCEPT TO THE EXTENT RIGHTS ARE EXPRESSLY GRANTED TO OTHERS. THE RECIPIENT AGREES BY ACCEPTING THESE DRAWINGS NOT TO SUPPLY OR DISCLOSE ANY INFORMATION REGARDING THEM TO ANY UNAUTHORIZED PERSONAL.

SIGNATURE: _____
 DATE: _____

March 2023

Anita Bartles
 County Clerk
 Saline County
 204 S High St / PO Box 865
 Wilber, NE 68465-0865

RE: Insurance Renewal for Saline County, Group # 020406
 Life and Long-Term Disability, Madison National Life Insurance Company, Inc.
 Carrier Policy # 4195, NIS Policy # 8270 and Carrier Policy # 1261, NIS Policy # 7672

Dear Ms. Bartles:

The Life and LTD Insurance renews July 1, 2023. I am pleased to inform you that Madison National Life Insurance Company, Inc. has determined that a rate adjustment is not needed. Your renewal rates are as follows:

	Current Rate Per \$1,000 of Coverage	Renewal Rate Per \$1,000 of Coverage	Impact
Life and AD&D	\$0.18/ \$0.03	\$0.18/ \$0.03	Pass/ Pass
Supplemental Life	Age Rated	Age Rated	Pass
Supplemental AD&D	\$0.03	\$0.03	Pass
Dependent Spouse Life	Age Rated	Age Rated	Pass
Dependent Child Life	\$0.15	\$0.15	Pass

The above Life rates are guaranteed for 2 Years until July 1, 2025, assuming no changes to the current benefit structure.

Long-Term Disability

Class #	Class Title	Current Rate Per Person Per Month	Renewal Rate Per Person Per Month	Impact
01	ALL ELIGIBLE EMPLOYEES WHO ARE 1) NOT PARTICIPATING IN NACO BLUE CROSS BLUE SHIELD OF NEBRASKA; AND 2) ENROLLED IN THE CORE PLAN ONLY	\$2.27	\$2.27	Pass
02	ALL ELIGIBLE EMPLOYEES WHO ARE 1) NOT PARTICIPATING IN NACO BLUE CROSS BLUE SHIELD OF NEBRASKA; AND 2) ENROLLED IN CORE PLAN AND ELECTING THE BUY-UP PLAN	\$0.26	\$0.26	Pass
03	ALL ELIGIBLE EMPLOYEES WHO ARE 1) PARTICIPATING IN NACO BLUE CROSS BLUE SHIELD OF NEBRASKA; AND 2) ELECTING THE BUY-UP PLAN	\$0.26	\$0.26	Pass

The above LTD rates are guaranteed for 2 Years until July 1, 2025, assuming no changes to the current benefit structure.

We believe our level of commitment to you is most evident in our ongoing efforts to secure both competitive pricing and extended rate guarantees. We truly appreciate your business and the opportunity to continue negotiating on your behalf.

In return for your commitment to National Insurance Services (NIS), NIS agrees to provide the following:

- Annual Best Practices Service Visit or Call
- Dedicated Account Representative
- Dedicated Client Relations Representative
- Dedicated Billing Representative
- Free Gap Analysis (when requested)
- Compliance with State Bid Laws
- Monitoring Market Conditions

By signing the below, you are acknowledging your reciprocal 2 Year commitment to NIS. In pricing the renewal, the claims risk and administrative expenses are spread over the rate guarantee. In exchange for our rate guarantee, you must remain directly contracted with NIS for the duration of the rate guarantee. In the event you cancel prior to the end of the rate guarantee a risk charge in the amount of 1% of annual premium will be assessed for each month remaining on the rate guarantee.

Please complete the bottom portion and return a copy to National Insurance Services as indication of your acceptance of the renewal. Thank you for your continued business. Please do not hesitate to call me if you have any questions.

Sincerely,



Erin Eby
Account Representative, Insured Products

The July 1, 2023 renewal of Group Life Insurance as outlined above is accepted.

Signature & Title _____ Date 05-23-2023 **Phil Hardenburger, Board Chairperson**

Renewal eForm # 13020

Insurance Renewal for Saline County, Group # 020406
Life and Long-Term Disability, Madison National Life Insurance Company, Inc.
Carrier Policy # 4195, NIS Policy # 8270 and Carrier Policy # 1261, NIS Policy # 7672

NACO VSP Vision Insurance Plan Renewal



Group Contact Name: Jamie Woltemath **Group Name:** Saline County

The NACO Vision Insurance for your group renews July 1, 2023. After careful review of the current plan, Vision Service Plan is adjusting the rates as follows:

		Current Rate per Person per Month	Renewal Rate per Person per Month	Impact
Rates	Employee Only	\$8.51	\$9.62	Increase
	Employee + Spouse	\$17.09	\$19.31	Increase
	Employee + Child(ren)	\$21.00	\$23.73	Increase
	Employee + Family	\$28.17	\$31.84	Increase

The above rates are guaranteed for 4 Years until July 1, 2027, assuming no changes to the current benefit structure.

		Current Plan	Renewal Plan
Additional benefits available:	Anti-Reflective Coating	On Average \$79	\$40 Co-pay
	LightCare	N/A	Members can use their benefit to purchase ready-made non-prescription blue light filtering or ready-made non-prescription sunglasses.

We believe our level of commitment to you is most evident in our ongoing efforts to secure both competitive pricing and extended rate guarantees. We truly appreciate your business and the opportunity to continue negotiating on your behalf. By signing below, you are acknowledging your reciprocal 4 Year commitment to National Insurance Services.

Signature: _____

Print Name: Phil Hardenburger

Date: May 23, 2023

When form has been completed, signed, and dated: Email to Tammie Matti, Client Relations, at tmatti@NISBenefits.com.

Your VSP Vision Benefits Summary

NACO BENEFIT SERVICES and VSP provide you with an affordable vision plan.

PROVIDER NETWORK:

VSP Choice

EFFECTIVE DATE:

07/01/2023



BENEFIT	DESCRIPTION	COPAY	FREQUENCY
Your Coverage with a VSP Provider			
WELLVISION EXAM	• Focuses on your eyes and overall wellness	\$10	Every 12 months
PRESCRIPTION GLASSES		\$25	See frame and lenses
FRAME*	<ul style="list-style-type: none"> • \$205 featured frame brands allowance • \$185 frame allowance • 20% savings on the amount over your allowance • \$100 Walmart® / Costco® frame allowance 	Included in Prescription Glasses	Every 12 months
LENSES	<ul style="list-style-type: none"> • Single vision, lined bifocal, and lined trifocal lenses • Impact-resistant lenses for dependent children 	Included in Prescription Glasses	Every 12 months
LENS ENHANCEMENTS	<ul style="list-style-type: none"> • UV Coating • Standard progressive lenses • Anti-Reflective • Premium progressives lenses • Custom progressive lenses • Average savings of 30% on other lens enhancements 	\$0 \$0 \$40 \$95 - \$105 \$150 - \$175	Every 12 months
CONTACTS (INSTEAD OF GLASSES)	<ul style="list-style-type: none"> • \$140 allowance for contacts; copay does not apply • Contact lens exam (fitting and evaluation) 	Up to \$60	Every 12 months
LIGHTCARE™†	• \$185 allowance for ready-made non-prescription sunglasses, or ready-made non-prescription blue light filtering glasses, instead of prescription glasses or contacts	\$25	Every 12 months
ESSENTIAL MEDICAL EYE CARE	<ul style="list-style-type: none"> • Retinal screening for members with diabetes • Additional exams and services for members with diabetic eye disease, glaucoma, or age-related macular degeneration. Limitations and coordination with your medical coverage may apply. Ask your VSP doctor for details. 	\$0 \$20 per exam	Available as needed
ADDITIONAL COVERAGE	• Additional Pairs of Eyewear; Within 12 months of exam, 20% off unlimited additional pairs of prescription glasses and sunglasses, from any VSP provider within 12 months of your last WellVision Exam.		
EXTRA SAVINGS	<p>Glasses and Sunglasses</p> <ul style="list-style-type: none"> • Extra \$20 to spend on featured frame brands. Go to vsp.com/offers for details. • 20% savings on additional glasses and sunglasses, including lens enhancements, from any VSP provider within 12 months of your last WellVision Exam. <p>Routine Retinal Screening</p> <ul style="list-style-type: none"> • No more than a \$39 copay on routine retinal screening as an enhancement to a WellVision Exam <p>Laser Vision Correction</p> <ul style="list-style-type: none"> • Average 15% off the regular price or 5% off the promotional price; discounts only available from contracted facilities 		
YOUR MONTHLY CONTRIBUTION	\$9.62 Member only	\$19.31 Member + spouse	\$23.73 Member + child(ren) \$31.84 Member + family

YOUR COVERAGE GOES FURTHER IN-NETWORK

With so many in-network choices, VSP makes it easy to get the most out of your benefits. You'll have access to preferred private practice, retail, and online in-network choices. Log in to vsp.com to find an in-network provider.

*Only available to VSP members with applicable plan benefits. Frame brands and promotions are subject to change.

†Savings based on doctor's retail price and vary by plan and purchase selection; average savings determined after benefits are applied. Ask your VSP network doctor for more details.

+Coverage with a retail chain may be different or not apply.

VSP guarantees member satisfaction from VSP providers only. Coverage information is subject to change. In the event of a conflict between this information and your organization's contract with VSP, the terms of the contract will prevail. Based on applicable laws, benefits may vary by location. In the state of Washington, VSP Vision Care, Inc., is the legal name of the corporation through which VSP does business. TruHearing is not available directly from VSP in the states of California and Washington.

To learn about your privacy rights and how your protected health information may be used, see the VSP Notice of Privacy Practices on vsp.com.

©2023 Vision Service Plan. All rights reserved.

VSP, Eyeconic, and WellVision Exam are registered trademarks of Vision Service Plan and VSP LightCare is a trademark of Vision Service Plan. Flexon and Dragon are registered trademarks of Marchon Eyewear, Inc. All other brands or marks are the property of their respective owners. 102898 VCCM

Put your eyes at ease with VSP LightCare

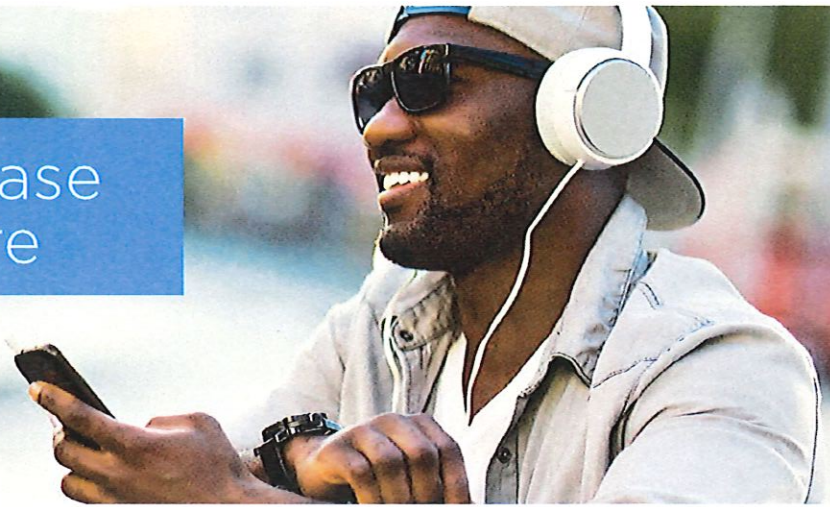

Why UV and Blue Light Coverage?

Even if you don't wear prescription glasses, an annual eye exam is an easy and cost-effective way to take care of your eyes and overall health.

With VSP LightCare™, you can use your frame and lens benefit to get non-prescription eyewear from your VSP® network doctor. Sunglasses or blue light filtering glasses may be just what you're looking for.

KEEP YOUR EYES PROTECTED OUTDOORS AND IN:

Always wear sunglasses outdoors. Protect your eyes from the sun's ultraviolet rays that can damage your corneas and cause eye-related diseases like cataracts. 100% UVA and UVB protection is the best choice for your sunglasses.¹ Wear blue light filtering glasses indoors to combat digital eye strain. Digital screens and fluorescent lighting emit blue light that can contribute headaches, blurred vision, and sore eyes—all possible symptoms of digital eye strain.

PROVIDER CHOICES YOU WANT

The VSP Premier Program includes thousands of **private practice doctors** and more than 700 **Visionworks® retail locations** nationwide.



Prefer to shop online?

At **eyeconic.com**®, you'll be shopping at the preferred online retailer for VSP members where you can connect and use your benefits.²



Your VSP LightCare Coverage with a VSP Network Doctor*

Eye Exam

A fully covered comprehensive WellVision Exam®.¹

Eyewear

Visit a VSP network doctor and choose either prescription eyewear coverage, or use your frame and lens allowance toward ready-to-wear:

- non-prescription sunglasses *or*
- non-prescription blue light filtering glasses

*Register and log in to vsp.com to review your benefit information. Based on applicable laws; benefits may vary by location.

Questions? vsp.com | 800.877.7195

1. Less any applicable copay 2. Tips for Choosing the Best Sunglasses, American Academy of Ophthalmology, June 2021 3. To find out whether your employer participates in Eyeconic®, log in to vsp.com to check your vision benefits.

©2022 Vision Service Plan. All rights reserved.
VSP, Eyeconic, eyeconic.com, and WellVision Exam are registered trademarks, and VSP LightCare is a trademark of Vision Service Plan.
All other brands or marks are the property of their respective owners. 103187 VCCM

A Look at Your VSP Vision Coverage

With VSP and NACO BENEFIT SERVICES,
your health comes first.



Enroll in VSP® Vision Care to get access to savings and personalized vision care from a VSP network doctor for you and your family.

Value and savings you love.

Save on eyewear and eye care when you see a VSP network doctor. Plus, take advantage of Exclusive Member Extras which provide offers from VSP and leading industry brands totaling over \$3,000 in savings.

Provider choices you want.

vsp PREMIER PROGRAM Maximize your benefits at a Premier Program location, which is part of our incredible network of doctors.

Shop online and connect your benefits.

eyeconic Eyeconic® is the preferred VSP online retailer where you can shop in-network with your vision benefits. See your savings in real time when you shop over 70 brands of contacts, eyeglasses, and sunglasses.

Quality vision care you need.

You'll get great care from a VSP network doctor, including a WellVision Exam®. An annual eye exam not only helps you see well, but helps a doctor detect signs of eye conditions and health conditions, like diabetes and high blood pressure.

Using your benefit is easy!

Create an account on **vsp.com** to view your in-network coverage, find the VSP network doctor who's right for you, and discover savings with Exclusive Member Extras. At your appointment, just tell them you have VSP.

vsp
vision care |



More Ways
to Save

Extra
\$20

to spend on
Featured Brands†

bebe CALVIN KLEIN
COLE HAAN DRAGON
FLEXON LACOSTE
and more

See all brands and offers
at **vsp.com/offers**.

+

Up to
40%
Savings on
lens enhancements‡

Enroll through your employer today.
Contact us: **800.877.7195** or **vsp.com**



NEBRASKA ASSOCIATION OF COUNTY OFFICIALS

SUBGROUP APPLICATION

This Subgroup Application is hereby incorporated by this reference into the Master Group Application for the Nebraska Association of County Officials. The Master Group Application includes the Membership and Underwriting Guidelines.

Effective Date: This coverage shall be effective on July 1, 2023 provided this Application is accepted by us and payment of the charges is made as provided in this Application.

Renewal Date: July 1, 2023

APPLICANT INFORMATION

A. Subgroup Employer (Applicant) Saline County

Account No./ Group No. 100098 Sub Account/ Roll No. N/A Market Affiliation Code: 0891

Address 204 S. High St. City Wilber State NE Zip 68465

Billing Address (if different) Box 865 City Wilber State NE Zip 68465

Head of Firm/Decision Maker Phil Hardenburger, Chairperson

Group Leader/Correspondence Jamie Woltemath

Phone 402-821-2374 Email payroll@salinecountyne.gov

Employer (Tax) Identification Number (EIN) 47-6006503 NAICS Code 813940

AUTHORIZED PLAN CONTACTS

The HIPAA Privacy Rules provide that the Group Health Plan is a separate legal entity from the Employer/Plan Sponsor. In compliance with the Rules, it is necessary to designate Authorized Plan Contacts for the Group Health Plan.

The Group Health Plan (GHP) Primary Contact is indicated above. The GHP Primary Contact serves as BCBSNE's primary contact for the GHP, and may also designate additional Authorized Plan Contacts for the GHP. The GHP Primary Contact shall notify BCBSNE of any additions or deletions to the following list, by noting changes/additions below.

Please identify the individuals (including Group Leader and Head of Firm) to be given access to Group Health Plan Information received from BCBSNE in accordance with the requirements set forth within the HIPAA Privacy Rules. Please also identify all deletions to access from the prior year.

Authorized Plan Contacts

Reason for Change:

Please select all that apply:

New Delete

BluesEnroll Access? Yes No

Name: Jamie Woltemath

Email: payroll@salinecountyne.gov

Title: Payroll Clerk

Phone: 402-821-2374

Please select all that apply:

New Delete

BluesEnroll Access? Yes No

Name: Dee Drake

Email: payables@salinecountyne.gov

Title: Deputy County Clerk

Phone: 402-821-2374

BCBSNE will not release protected health information (PHI) to fully insured groups, except as specifically agreed in writing by BCBSNE, the Plan and Plan Sponsor. When there is a written agreement, all disclosure of PHI from BCBSNE shall be made to the Plan, or an Authorized Plan Contact.

Reason for Change:

Please select all that apply: New Delete

BluesEnroll Access? Yes No

Name: _____

Email: clerk@salinecountyne.gov

Title: County Clerk

Phone: 402-821-2374

Please select all that apply: New Delete

BluesEnroll Access? Yes No

Name: Phil Hardenburger

Email: commissioner2@salinecountyne.gov

Title: Chairperson

Phone: 402-826-9661

Please select all that apply: New Delete

BluesEnroll Access? Yes No

Name: Candace Meredith

Email: candace.meredith@nebraskacounties.org

Title: NACO Cobra Administrator

Phone: 402-434-5660 ext 223

Please select all that apply: New Delete

BluesEnroll Access? Yes No

Name: Mike Boden

Email: mike.boden@nebraskacounties.org

Title: Benefits Service Manager

Phone: 402-434-5660 ext 224

Please select all that apply: New Delete

BluesEnroll Access? Yes No

Name: _____

Email: _____

Title: _____

Phone: _____

Please select all that apply: New Delete

BluesEnroll Access? Yes No

Name: _____

Email: _____

Title: _____

Phone: _____

Please select all that apply: New Delete

BluesEnroll Access? Yes No

Name: _____

Email: _____

Title: _____

Phone: _____

ELIGIBILITY AND ENROLLMENT

A. EMPLOYEE ELIGIBILITY: To be eligible for coverage, an employee must work a minimum of 20 hours per week (must be at least 17½ hours) on a regular calendar year basis.

Eligibility Waiting Period 30 days (not to exceed 60 days). Please also complete applicable section below.

If a Waiting Period applies, employee's coverage is effective the first of the month following completion of the waiting period. If the waiting period ends on the first of a month, coverage will be effective (please check):

- that date (the 1st)
- the first of the month following the completion of the waiting period

If "0" Waiting Period days above, employee's coverage will be effective (please check):

- the first of the month following the 1st day of work.
- the first of the month following the 1st day of work, unless that day is the first of the month, then coverage is effective on the first of that month.
- the 1st day of work.

Dependents enrolling for coverage with the employee will be effective on the same date as the employee.

If an otherwise eligible employee is not actively at work on the effective date for other than personal health reasons, coverage for that employee will go into effect on the first of the month following his/her return to active employment, subject to our receipt of an enrollment form within 31 days of the return to work date.

Other Eligibility Provisions: _____

B. EMPLOYEE DATA: The following is from and agrees with your payroll and personnel records:

1. Total employees on the payroll on the effective date of the coverage:	<u>120</u>
2. Employees not eligible per the minimum number of hours or probationary period (above):	<u>3</u>
3. Eligible employees enrolled with BCBSNE and for whom required minimum contribution is made:	<u>77</u>
4. Eligible employees not enrolling due to group coverage through their spouse's employer	<u>25</u>
5. Number of eligible employees who have declined BCBSNE coverage for other reasons:	<u>12</u>
6. Total of Lines 2. through 5. (must equal line 1. above): (2. + 3. + 4. + 5.)	<u>120</u>
7. Number of eligible employees adjusted for coverage through their spouse: (1. - 2. - 4.)	<u>92</u>

C. LATE ENROLLMENT: Late enrollment is allowed only during the annual enrollment period in June of each year for a July 1 effective date.

Other Provisions: _____

D. Do you meet the definition of "Small Employer" as defined below? Yes No

Small employer shall mean any person, political subdivision, firm, corporation, limited liability company, partnership, or association that is actively engaged in business that, on at least 50% of its working days during the preceding calendar quarter, employed at least 2 and no more than 50 eligible employees, the majority of whom were employed within Nebraska. Eligible employee shall mean an employee who works on a full-time basis and has a normal work week of 30 or more hours.

E. OTHER: Does the Subgroup Applicant/Employer authorize Blue Cross and Blue Shield of Nebraska to administer all dependent coverage requests involving court-ordered alternate recipients, which will include reviewing and determining dependent coverage and notifications required by OBRA '93 regarding Qualified Medical Child Support Orders (QMCSO)?

- Yes
- No

F. COVERAGE OPTIONS

Health Coverage Options

\$600 Deductible w/copay
 \$1,100 Deductible w/copay
 \$1,600 Deductible
 \$2,600 Deductible
 \$2,600 Deductible w/copay
 \$3,900 Deductible
 \$6,100 Deductible w/copay
 \$6,100 - HSA HDHP
 Dual Option (Standard option & HDHP option)
 Yes
 No
 HSA Bank Name _____

Dental Coverage
 Yes
 No
 BCBSNE Dental Only
 Signature Blue Option 3 (Premier)
 Signature Blue Option 14 (Basic Passive PPO)

Do you have a Third Party HRA Administrator
 Yes
 No
If yes, identify vendor:
 Mid-American Benefits*
 First Concord*
 Other*: _____

*Not affiliated with Blue Cross and Blue Shield of Nebraska. HRA administration is provided solely by your HRA Administrator.

MONTHLY RATES AND EMPLOYER CONTRIBUTION

It is understood that the amount shown as your Contribution will be paid by you without charge to the Eligible Employees and the remainder collected by you from the Eligible Employees by payroll deduction and remitted monthly to us.

The Total Monthly Charge (below) should be completed as the full billed monthly premium.

The standard rates and the adjusted rates (based on rate reduction or surcharge determinations) for each health and dental option are as stated on the **Rate Sheets** attached to the Master Group Application.

Rate Determination Category (% of standard rate):

- 70%
 80%
 85%
 90%
 95%
 100%
 110%
 120%
 130%

The monthly charges for this coverage will not change prior to July 1, 2024. This rate guarantee and continuation of coverage is subject to the Applicant continuing to meet our underwriting guidelines.

Additional Information: _____

Charges and Contribution

	HEALTH (Standard Option)		HEALTH (HSA-HDHP Option)		DENTAL	
	Group Monthly Contribution	Total Monthly Charge	Group Monthly Contribution	Total Monthly Charge	Group Monthly Contribution	Total Monthly Charge
EE Only	\$1,070.96	\$1,070.96				
EE/Spouse	\$2,149.79	\$2,149.79				
EE/ Children	\$2,149.79	\$1,149.79				
Family	\$2,459.51	\$2,459.51				

Additional Comments regarding Charges and Contributions:



Anita K. Bartels
Saline County Clerk
Saline County Courthouse
204 S. High Street
P.O. Box 865
Wilber, NE 68465
Phone: 402-821-2374
clerk@salinecountyne.gov

May 23, 2023

Dear Saline County Board of Commissioners;

Please accept this letter as my official notice that I am retiring from Saline County on June 30, 2023.

Thank you for the opportunities and support you have provided me during my tenure with Saline County.

While I look forward to enjoying my retirement, I will miss working for you. If I can be of any assistance during this transition, please let me know.

Sincerely,

Anita K. Bartels

RESOLUTION #2023-27

BE IT HEREBY RESOLVED, by the Board of Commissioners of Saline County, NE,
that the sum of \$298.22 be transferred from account #2500 Grant Fund to #0100 General
Fund for the purpose of reimbursing the General Fund for Grant Retirement
Contributions. Reference Journal Entry #23060001.

Motion made by Commissioner _____, seconded by Commissioner
_____, to adopt the foregoing Resolution. All members present
voting as follows:

Yeas: _____

Nays: _____

Abstentions: _____

Absent: _____

Chairman

SUBSCRIBED AND SWORN TO before me this 23rd day of May, 2023

SEAL

Saline County Clerk

RESOLUTION #2023-29

BE IT HEREBY RESOLVED, by the Board of Commissioners of Saline County, NE,
that the sum of \$5,500.00 be transferred from the Inheritance Fund #2700 to the Juvenile
Services Aid Program Fund #2516, to be reimbursed when funds are available.

Motion made by Commissioner _____, seconded by Commissioner
_____, to adopt the foregoing Resolution. All members present
voting as follows:

Yeas: _____

Nays: _____

Abstentions: _____

Absent: _____

Chairman

SUBSCRIBED AND SWORN TO before me this 23rd day of May, 2023

SEAL

Saline County Clerk

APR 19 2023



CHANGE ORDER

Project: Saline County Box Culvert
C-76(778)

Contractor: Van Kirk Brothers Contracting
P. O. Box 585
Sutton, NE 68979

Change Order No.: 1 (Final)
Date: 4/18/2023
Engineers Project No.: C-76(778)
Contract Date: May-21

The Contract has changed as follows:

1. Original Contract Item Overruns/Underruns

The following remaining items were either overrun or underrun to meet the project's As-Built conditions.

Below is a breakdown of those items.

Item No.	Description	Plan Qty.	Unit Cost	As-Built Qty.	Overrun	Underrun
1.3	Crushed Rock Surface Course	479.00 TN	\$50.00	490.43 TN	\$ 571.50	
1.6	Covercrop Seeding	1.00 AC	\$300.00	0.00 AC		\$ (300.00)
1.9	Temporary Silt Fence	200.00 LF	\$3.25	0.00 LF		\$ (650.00)
TOTAL					\$ 571.50	\$ (950.00)
NET					\$ (378.50)	

Due to the Original Contract Item Overrun/Underrun the total project cost will be decreased by -\$378.50.

NOT VALID UNTIL SIGNED BY THE OWNER, ENGINEER AND CONTRACTOR

Original Contract Sum.....	\$208,567.10
Net change by previously authorized Change Orders.....	\$0.00
The Contract Sum prior to this Change Order was.....	\$208,567.10
The Contract Sum will be Increased/Decreased	-\$378.50
The new Contract Sum including Change Order will be.....	\$208,188.60

Engineer	Contractor	Owner
Speece Lewis Engineers, Inc.	Van Kirk Brothers Contracting	Saline County
Address	Address	Address
906 South 26th Street	P. O. Box 585	P. O. Box 865
Lincoln, NE 68510	Sutton, NE 68979	Wilber, NE 68465
By <u>Monte Hobelman</u>	By _____	By _____
Date <u>4/18/2023</u>	Date _____	Date _____

APS7040
5/19/23
16:05:39

SALINE
BOARD PREAPPROVAL REPORT
GENERAL
FROM 06/02/2023 TO 06/02/2023

Account #	Description	Account Amt	Vendor	Invoice Description	Claim #
601-00 BOARD					
00-2-1704	MILEAGE ALLOWANCE	300.65	MARVIN KOHOUT	MAR23 MILEAGE	23060031
00-2-1801	DUES, SUB, REG, & TRAINING	250.00	NACO	KOHOUT KOHOUT HARDENBURGER	23060042

	601-00 BOARD	550.65			

602-00 CLERK					
00-2-0100	POSTAL SERVICES	249.51	QUADIENT LEASING USA, INC	INV 60136237 INV N9925468	23060047
00-2-0100 7	POSTAL SERVICES	75.00	QUADIENT LEASING USA, INC	INV 60136237 INV N9925468	23060047
00-2-1801	DUES, SUB, REG, & TRAINING	125.00	NACO	KOHOUT KOHOUT HARDENBURGER	23060042

	602-00 CLERK	449.51			

603-00 TREASURER					
00-2-0100	POSTAL SERVICES	499.02	QUADIENT LEASING USA, INC	INV 60136237 INV N9925468	23060047
00-2-0100 7	POSTAL SERVICES	150.00	QUADIENT LEASING USA, INC	INV 60136237 INV N9925468	23060047
00-2-1200	OFFICE EQUIPMENT REPAIR	457.20	VISA	VISA #6613	23060072
00-2-2000	PRINTING AND PUBLISHING	20.00	VISA	VISA #6613	23060072
00-3-0101	OFFICE SUPPLIES	153.66	EAKES OFFICE PLUS	ACCT 210447 ACCT 210498 INV	23060012
00-3-0101	OFFICE SUPPLIES	55.99	QUILL CORPORATION	INV 32372631	23060048
00-3-0101	OFFICE SUPPLIES	43.84	VISA	VISA #6613	23060072

	603-00 TREASURER	1,379.71			

605-00 ASSESSOR					
00-2-0100 7	POSTAL SERVICES	75.00	QUADIENT LEASING USA, INC	INV 60136237 INV N9925468	23060047
00-2-1100	DATA PROCESSING COSTS	3,740.00	ESRI-ENVIRONMENTAL SYS RE	Q# 26144731	23060016
00-2-1700	TRAVEL EXPENSES	19.67	VISA	VISA #3268	23060067
00-2-1704	MILEAGE ALLOWANCE	177.50	DARYL CLARK	MILEAGE	23060005
00-2-2000	PRINTING & PUBLISHING	335.00	SEWARD COUNTY INDEPENDENT	INV 166076 INV 165919 INV 1	23060053
00-2-3900	CONTRACTOR FOR REAPPRAISAL	5,070.00	STANARD APPRAISAL SERVICE	INV 3094	23060056
00-2-3920	CONTRACTURAL SERVICES	11,970.00	GWORKS	INV 2019-13818 INV 2019-164	23060025
00-3-0101	OFFICE SUPPLIES	135.01	EAKES OFFICE PLUS	ACCT 210447 ACCT 210498 INV	23060012
00-5-0500	OFFICE EQUIPMENT	249.51	QUADIENT LEASING USA, INC	INV 60136237 INV N9925468	23060047

	605-00 ASSESSOR	21,771.69			

608-00 PLANNING-ZONING COMMISSION					
00-2-1704 7	MILEAGE ALLOWANCE	29.41	GERALD L BROWN	5/16 MEETING	23060004
00-2-1704 7	MILEAGE ALLOWANCE	62.16	MARK DUE	5/16 MEETING	23060011
00-2-1704 7	MILEAGE ALLOWANCE	16.31	DAVID LYNN HERMSMEIER	5/16 MEETING	23060027
00-2-1704 7	MILEAGE ALLOWANCE	29.41	JEFFREY D KOLL	5/16 MEETING	23060032

APS7040
5/19/23
16:05:39

SALINE
BOARD PREAPPROVAL REPORT
GENERAL
FROM 06/02/2023 TO 06/02/2023

Account #	Description	Account Amt	Vendor	Invoice Description	Claim #
00-2-1704	7 MILEAGE ALLOWANCE	19.59	KEITH L MULLER	5/16 MEETING	23060041
00-2-1704	7 MILEAGE ALLOWANCE	62.16	MARY JO WEBER	5/16 MEETING	23060075
00-2-2000	PRINTING AND PUBLISHING	42.50	SEWARD COUNTY INDEPENDENT	INV 166076 INV 165919 INV 1	23060053
00-3-0101	SUPPLIES-OFFICE	59.24	VISA	VISA #4030	23060073
00-5-0315	DATA PROCESSING EQUIPMENT	2,898.00	GWORKS	INV 2019-13818 INV 2019-164	23060025
00-5-0500	OFFICE EQUIPMENT	20.35	VISA	VISA #4030	23060073
608-00 PLANNING-ZONING COMMISSION		3,239.13			
610-00 VOICE/DATA SERVICES					
00-4-0201	DATA PROCESSING-MIPS	56.88	STATE OF NE-DEPT OF ADMIN	INV 1370283	23060057
00-4-0205	7 MOBILE PHONE SERVICES	2,084.93	VERIZON WIRELESS	INV 9934598885	23060066
00-4-0205	MOBILE PHONE SERVICES	1,431.07	WINDSTREAM	ACCT 092157118 ACCT 0909353	23060077
610-00 VOICE/DATA SERVICES		3,572.88			
621-00 CLERK OF DIST. COURT					
00-2-1200	OFFICE EQUIPMENT REPAIR	343.98	EAKES OFFICE PLUS	ACCT 210447 ACCT 210498 INV	23060012
621-00 CLERK OF DIST. COURT		343.98			
622-00 COUNTY COURT SYSTEM-JUDGE					
00-3-0101	OFFICE SUPPLIES	170.15	EAKES OFFICE PLUS	ACCT 210447 ACCT 210498 INV	23060012
622-00 COUNTY COURT SYSTEM-JUDGE		170.15			
631-00 CLERK OF DIST. COURT CHILD SUPPORT					
00-2-2909	CHILD SUPPORT SURVEY	1,300.00	MAXIMUS INC	INV 02	23060038
631-00 CLERK OF DIST. COURT CHILD SUPPORT		1,300.00			
641-00 BUILDING & GROUNDS (COURT HOUSE)					
00-3-0103	JANITORIAL SUPPLIES	27.99	CRETE ACE HARDWARE #82123	ACCT 212374	23060008
00-3-0103	JANITORIAL SUPPLIES	50.25	DOLLAR GENERAL CHARGE SAL	ACCT 899593338	23060010
00-3-0209	7 FUEL	6.54	SHOP QWIK	APR23	23060054
00-5-0230	7 BUILDING IMPROVEMENTS	162.00	NEBRASKA STATE FIRE MARSH	INV 127906	23060043
00-5-0230	BUILDING IMPROVEMENTS	1,250.80	SIEMENS INDUSTRY INC	INV 5330881705	23060055
00-5-0319	JANITORIAL EQUIPMENT	14.99	CRETE ACE HARDWARE #82123	ACCT 212374	23060008
641-00 BUILDING & GROUNDS (COURT HOUSE)		1,512.57			

SALINE
BOARD PREAPPROVAL REPORT
GENERAL
FROM 06/02/2023 TO 06/02/2023

Account #	Description	Account Amt	Vendor	Invoice Description	Claim #

645-00	EXTENSION OFFICE				
00-1-0101	7 SALARY - BOARD MEMBERS	36.25	SANDRA J KRIVOHAVEK	5/3 MILEAGE 5/3 MEETING	23060034
00-1-0101	7 SALARY - BOARD MEMBERS	1,400.00	NICKLES PAINTING	EXT OFFICE	23060045
00-1-0101	7 SALARY - BOARD MEMBERS	27.50	KELLEN EUGENE NOVAK	5/3 MILEAGE 5/3 MEETING	23060046
00-1-0101	7 SALARY - BOARD MEMBERS	48.75	DEBORAH L STEUK	5/3 MILEAGE 5/3 MEETING	23060058
00-2-1704	MILEAGE ALLOWANCE	28.82	INGRID LINDAL	MILEAGE	23060036
00-2-1704	7 MILEAGE ALLOWANCE	72.71	ANITA STOUGARD	MILEAGE	23060059
00-2-1704	MILEAGE ALLOWANCE	148.03	BECKY VALES	MILEAGE	23060064
00-2-1704	7 MILEAGE ALLOWANCE	400.66	MADELINE WERNER	MILEAGE	23060076
00-3-0101	OFFICE SUPPLIES	87.73	UNL COOPERATIVE EXTENSION	REIMB QUILL	23060063
00-3-0101	OFFICE SUPPLIES	288.00	VISA	VISA #8630	23060070
00-5-0500	OFFICE EQUIPMENT	2,105.43	UNIVERSITY OF NEBRASKA	INV 2023-NM-1	23060062

645-00 EXTENSION OFFICE		4,643.88			

652-00	ATTORNEY				
00-2-9900	MISCELLANEOUS	257.40	SEWARD COUNTY INDEPENDENT	INV 166076 INV 165919 INV 1	23060053
00-3-0101	OFFICE SUPPLIES	101.57	EAKES OFFICE PLUS	ACCT 210447 ACCT 210498 INV	23060012
00-5-0500	OFFICE EQUIPMENT	337.63	GREATAMERICA FINANCIAL SV	INV 34011114	23060022

652-00 ATTORNEY		696.60			

662-00	ATTORNEY-CHILD SUPPORT				
00-2-1801	7 DUES, SUB, REG, & TRAINING	14.99	EQUIFAX WORKFORCE SOLUTIO	INV 2054966668	23060015
00-2-1801	DUES, SUB, REG, & TRAINING	155.57	THOMSON REUTERS	INV 848221359 INV 84832258	23060061
00-2-2909	CHILD SUPPORT SURVEY	1,300.00	MAXIMUS INC	INV 02	23060038

662-00 ATTORNEY-CHILD SUPPORT		1,470.56			

671-00	JAIL				
00-1-1100	7 UNIFORM ALLOWANCE	703.21	MALLORY SAFETY AND SUPPLY	INV 5619667 INV 5622029 INV	23060037
00-1-1100	UNIFORM ALLOWANCE	132.00	DILLON SEMRAD	ORD20041576023	23060052
00-2-1801	DUES, SUB, REG, & TRAINING	197.75	CONSOLIDATED MANAGEMENT C	INV 225040 INV 225081	23060006
00-2-1801	DUES, SUB, REG, & TRAINING	78.44	LANGUAGE LINE SERVICES IN	INV 10991723	23060035
00-2-1900	BOARD OF PRISONERS-MEALS	10,046.38	SUMMIT FOOD SERVICE LLC	INV 2000173356 INV 20001740	23060060
00-2-3000	6 MEDICAL SERVICES	9.71	CRETE AREA MEDICAL CENTER	CNTL#824630800 EMPLOYEE PHY	23060009
00-2-3000	6 MEDICAL SERVICES	330.00	FRIEND COMMUNITY HEALTHCA	DOS 5/10/23 DOS 5/4/23	23060021
00-2-3000	7 MEDICAL SERVICES	691.24	ZAC KEATING DDS	04/02/1992 06/06/1987 06/06	23060030
00-2-9900	MISCELLANEOUS	75.99	CRETE ACE HARDWARE #82121	ACCT 212111	23060007
00-2-9900	MISCELLANEOUS	285.00	CRETE AREA MEDICAL CENTER	CNTL#824630800 EMPLOYEE PHY	23060009
00-2-9900	MISCELLANEOUS	654.40	ENTENMANN-ROVIN COMPANY	ORD 0183716	23060014
00-3-0103	7 JANITORIAL SUPPLIES	42.06	THE HOME DEPOT PRO	INV 741639959	23060028
00-3-0103	JANITORIAL SUPPLIES	62.34	WALKER UNIFORM RENTAL	ACCT 5601	23060074
00-3-0211	TIRES/REPAIR	24.99	FARMERS COOPERATIVE	ACCT 649770 ACCT 1715	23060017

SALINE
BOARD PREAPPROVAL REPORT
GENERAL
FROM 06/02/2023 TO 06/02/2023

Account #	Description	Account Amt	Vendor	Invoice Description	Claim #

	671-00 JAIL	13,333.51			

693-00	EMERGENCY MANAGEMENT (CIVIL DEF)				
00-3-0209	FUEL	70.31	VISA	VISA #6723	23060069

693-00	EMERGENCY MANAGEMENT (CIVIL DEF)	70.31			

733-00	WEED CONTROL				
00-2-1630	SPRAYING EQUIPMENT REPAIR	341.44	MENARDS LINCOLN STORE SOU	INV 7395	23060039
00-2-1630	SPRAYING EQUIPMENT REPAIR	52.01	VISA	VISA #4030	23060073
00-2-2000	PRINTING & PUBLISHING	364.49	SEWARD COUNTY INDEPENDENT	INV 166076 INV 165919 INV 1	23060053
00-3-0106	SHOP SUPPLIES	140.01	VISA	VISA #4030	23060073
00-5-0315	DATA PROCESSING EQUIPMENT	770.00	ESRI-ENVIRONMENTAL SYS RE	Q# 26144731	23060016

733-00	WEED CONTROL	1,667.95			

803-00	VETERANS SERVICE				
00-5-1500	7 GRAVE MARKERS - FLAGS	984.32	FLAGZ @ THE BRAND	INV 2495	23060020

803-00	VETERANS SERVICE	984.32			

970-00	MISCELLANEOUS & MISC. COURTS				
00-1-0800	INSURANCE (DEDUCTIBLES)	5,374.02	FIRST CONCORD BENEFITS GR	3/27-4/2/23 3/6-12/23 3/14-	23060018
00-1-1000	OASI-SOCIAL SECURITY	49,089.75	FIRST STATE BANK FED TAX	3RD QTR 21	23060122
00-1-1400	MISCELLANEOUS INS	469.00	FIRST CONCORD BENEFITS GR	MAY 2023	23060019
00-2-2000	PRINTING AND PUBLISHING (P & P	729.72	SEWARD COUNTY INDEPENDENT	INV 166076 INV 165919 INV 1	23060053
00-2-2301	DIST COURT JURY FEES	118.62	VISA	VISA #8604	23060068
00-2-2411	9 DISTRICT COURT ATTORNEY FEES	2,223.00	HANSON HROCH & KUNTZ	CR20-70	23060026
00-2-2411	9 DISTRICT COURT ATTORNEY FEES	665.00	KALKWARF & SMITH LAW OFFI	CR21-59 JV 22-108	23060029
00-2-2411	9 DISTRICT COURT ATTORNEY FEES	7,432.49	MATTHEW K KOSMICKI	CR 22-4 CR 22-80 CR 23-14 C	23060033
00-2-2414	JUVENILE ATTORNEY	470.25	REBECCA ANDERSON	JV 22 118	23060002
00-2-2414	9 JUVENILE ATTORNEY	475.00	KALKWARF & SMITH LAW OFFI	CR21-59 JV 22-108	23060029
00-2-2515	9 CONTRACTUAL SERVICES (PUBLIC D	200.00	GROPP LAW AND MEDIATION L	PEREZ INV 552	23060023
00-2-2515	9 CONTRACTUAL SERVICES (PUBLIC D	6,666.67	SCOTT RYAN GROPP, ATTORNE	JUN23 CONTRACT	23060024
00-2-2601	DISTRICT COURT COSTS	117.57	SALINE COUNTY DISTRICT CO	CLAIM CI 23 66 MELANIE FORT	23060050
00-2-2601	DISTRICT COURT COSTS	653.00	THOMSON REUTERS	INV 848221359 INV 84832258	23060061
00-2-2602	COUNTY COURT COSTS	24.50	NEBRASKA.GOV	INV 7 INV 7566466	23060044
00-2-2602	COUNTY COURT COSTS	20.00	SECRETARY OF STATE RULES	TITLE 177 MAY	23060051
00-2-2700	MENTAL HEALTH BOARD COSTS	258.95	JOSEPH BIXBY	MH 23-1	23060003
00-2-2700	7 MENTAL HEALTH BOARD COSTS	305.02	MIDWEST COURT REPORTING I	MH 23-1	23060040
00-2-2700	6 MENTAL HEALTH BOARD COSTS	258.95	CARROLL L VERHAGE MD	CASE MH 23-1	23060065

SALINE
BOARD PREAPPROVAL REPORT
GENERAL
FROM 06/02/2023 TO 06/02/2023

Account #	Description	Account Amt	Vendor	Invoice Description	Claim #
00-2-2800	INSTITUTIONAL COSTS	1,070.00	REGION V SYSTEMS	INV 23-0523 INV 23-0515	23060049
00-2-5871	EMPLOYEE RECOGNITION	90.12	CRETE ACE HARDWARE #82123	ACCT 212374	23060008
00-2-5871	EMPLOYEE RECOGNITION	18.99	VISA	ACCT 1590	23060071
00-2-9900	7 MISCELLANEOUS	575.00	ALL STAR GLASS OF LINCOLN	WO WAS5020360	23060001
00-2-9900	MISCELLANEOUS	3,366.00	ELECTRONIC CONTRACTING CO	QUOTE 43214	23060013
00-3-0150	MISC. VEHICLE SUPPLIES (CAR EX	406.35	FARMERS COOPERATIVE	ACCT 649770 ACCT 1715	23060017
00-3-0150	7 MISC. VEHICLE SUPPLIES (CAR EX	238.77	SHOP QWIK	APR23	23060054
970-00 MISCELLANEOUS & MISC. COURTS		81,316.74	*****		
0100 GENERAL FUND		138,474.14	*****		
705-00 BRIDGE/ROAD MAINTENANCE					
00-2-0100	POSTAGE	32.70	VISA	ACCT 1590	23060095
00-2-0501	LIGHT	521.97	NORRIS PUBLIC POWER	ACCT 124625900	23060091
00-2-0502	WATER	44.35	CITY OF FRIEND	ACCT 523 ACCT 1986	23060082
00-2-0502	WATER	31.52	VILLAGE OF SWANTON	ACCT 207	23060094
00-2-0504	SEWER	18.00	VILLAGE OF SWANTON	ACCT 207	23060094
00-2-0505	GARBAGE	16.01	VILLAGE OF SWANTON	ACCT 207	23060094
00-2-1400	ROAD EQUIPMENT REPAIR PARTS	144.55	ANDERSON AUTO GROUP	INV 15441806	23060079
00-2-1400	ROAD EQUIPMENT REPAIR PARTS	954.93	CRETE AUTO SUPPLY INC	ACCT 4575	23060085
00-2-1400	ROAD EQUIPMENT REPAIR PARTS	407.89	FARMERS UNION COOP CO	ACCT SALINE	23060088
00-2-1600	OTHER EQUIPMENT REPAIR	184.93	CRETE ACE HARDWARE #82127	ACCT 212737	23060083
00-2-1800	OPERATING EXPENSES	12.00	VISA	ACCT 1590	23060095
00-3-0106	SHOP SUPPLIES	69.57	CRETE ACE HARDWARE #82127	ACCT 212737	23060083
00-3-0108	ELECTRICAL SUPPLIES	44.99	CRETE ACE HARDWARE #82127	ACCT 212737	23060083
00-3-0108	ELECTRICAL SUPPLIES	1,186.44	VOGT ELECTRIC	FRIEND SHOP	23060096
00-3-0110	SMALL TOOLS, ETC.	10.99	CRETE ACE HARDWARE #82127	ACCT 212737	23060083
00-3-0110	SMALL TOOLS, ETC.	43.99	FARMERS UNION COOP CO	ACCT SALINE	23060088
00-3-0202	GRAVEL AND BORROW	47,068.56	BEATRICE CONCRETE CO INC	INV P1 183472 INV P1 18347	23060081
00-3-0202	GRAVEL AND BORROW	10,892.44	JOHNSON SAND & GRAVEL CO	INV 11245A INV 11246A	23060090
00-3-0209	MACHINERY & EQUIPMENT FUEL	830.80	FARMERS UNION COOP CO	ACCT SALINE	23060088
00-3-0210	MACHINERY & EQUIPMENT GREASE-O	29.99	CRETE AUTO SUPPLY INC	ACCT 4575	23060085
00-3-0210	MACHINERY & EQUIPMENT GREASE-O	210.64	FARMERS UNION COOP CO	ACCT SALINE	23060088
00-3-0211	MACHINERY & EQUIPMENT TIRES-RE	135.14	FARMERS UNION COOP CO	ACCT SALINE	23060088
00-3-0215	OTHER ROAD/BRIDGE MATERIAL	180.00	FARMERS UNION COOP CO	ACCT SALINE	23060088
00-3-0301	SIGNS	622.00	B'S ENTERPRISES INC	INV 223542	23060080
00-3-0400	MISCELLANEOUS	19.99	CRETE ACE HARDWARE #82127	ACCT 212737	23060083
00-3-0400	MISCELLANEOUS	12.98	CRETE AUTO SUPPLY INC	ACCT 4575	23060085
00-3-0400	MISCELLANEOUS	12.75	FARMERS UNION COOP CO	ACCT SALINE	23060088
00-3-0400	MISCELLANEOUS	79.42	VISA	ACCT 1590	23060095
00-5-0318	SAFETY EQUIPMENT	120.95	CRETE LUMBER & FARM SUPPL	ACCT 20041	23060086
00-5-0500	OFFICE EQUIPMENT	330.00	ESRI-ENVIRONMENTAL SYS RE	Q# 26144731	23060087
00-5-1207	STRUCTURES, PIPES, BX, CULVERT	9,472.00	ACE IRRIGATION & MFG CO I	INV 006889	23060078
00-5-1302	ENGINEERING FEES	5,140.64	SPEECE-LEWIS ENGINEERS	INV 12405 INV 12437 INV 124	23060093

APS7040
5/19/23
16:05:39

SALINE
BOARD PREAPPROVAL REPORT
ROAD & BRIDGE
FROM 06/02/2023 TO 06/02/2023

Account #	Description	Account Amt	Vendor	Invoice Description	Claim #
00-5-1306	DRUG TESTING FEES & SUPPLIES	215.00	CRETE AREA MEDICAL CENTER	ACCT 8021733	23060084
00-5-1307	ADVERTISEMENT FOR BIDS	57.80	SEWARD COUNTY INDEPENDENT	INV 165924	23060092
00-5-1309	SIMPLE SIGNS COMPUTER PROGRAM	2,898.00	GWORCS	INV 2019-13817	23060089
00-5-1400	MISCELLANEOUS	1,224.42	VISA	ACCT 1590	23060095
705-00 BRIDGE/ROAD MAINTENANCE		83,278.35			
0300 ROAD & BRIDGE FUND		83,278.35			
879-00 VISITORS PROMOTION					
00-2-6040 7	VISITOR PROMOTION	1,500.00	NEBRASKA CZECHS OF WILBER SEWARD IND		23060097
879-00 VISITORS PROMOTION		1,500.00			
0990 VISITORS PROMOTION FUND		1,500.00			
604-00 REGISTER OF DEEDS					
00-2-9900	MISCELLANEOUS	220.00	MIPS INC	INV 23059102	23060098
604-00 REGISTER OF DEEDS		220.00			
1150 REGISTER OF DEEDS FUND		220.00			
612-00 EMPLOYEE WELLNESS					
00-3-0124	AWARDS/INCENTIVES	70.24	VISA	ACCT 8013	23060099
612-00 EMPLOYEE WELLNESS		70.24			
1502 EMPLOYEE WELLNESS FUND		70.24			

APS7040
5/19/23
16:05:39

SALINE
BOARD PREAPPROVAL REPORT
EMPLOYEE WELLNESS
FROM 06/02/2023 TO 06/02/2023

Account # 1099 Description Account Amt Vendor Invoice Description Claim #

Account #	Description	Account Amt	Vendor	Invoice Description	Claim #
837-00	AGING SERVICES				
00-1-1400	7 PROGRAM EXPENSE	285.00	SAMANTHA COSAERT	PROGRAM EXPENS	23060102
00-1-1400	PROGRAM EXPENSE	108.69	VISA	VISA #8975	23060108
00-2-1200	HISPANIC OUTREACH	120.00	CITY OF CRETE	INV 2007	23060101
00-2-1200	7 HISPANIC OUTREACH	262.50	MARCIA EMAL	FOOT CLINIC	23060104
00-2-1200	7 HISPANIC OUTREACH	150.00	PURFOODS, LLC DBA MOM'S M	INV MM042023	23060106
00-2-1200	HISPANIC OUTREACH	221.49	VISA	VISA #8975	23060108
00-2-1200	HISPANIC OUTREACH	660.00	WILBER CARE CENTER	APR23 STMT	23060109
00-2-1704	7 MILEAGE ALLOWANCE	77.68	MARCIA EMAL	FOOT CLINIC	23060104
00-2-9900	MISCELLANEOUS	1,350.00	AGING PARTNERS ACCOUNTING	INV FY2223UPT	23060100
00-2-9900	MISCELLANEOUS	36.00	CULLIGAN OF CRETE	INV 60845	23060103
00-2-9900	MISCELLANEOUS	27.47	VISA	VISA #3108	23060107
00-2-9900	MISCELLANEOUS	56.91	VISA	VISA #8975	23060108
00-3-0150	VEHICLE REPAIR	105.72	FARMERS COOPERATIVE	ACCT 5654	23060105

837-00 AGING SERVICES *****
3,461.46

2250 AGING SERVICES FUND *****
3,461.46

672-00	DRUG COURT				
00-2-2515	9 CONTRACTED SERVICES	1,200.00	KALKWARF & SMITH LAW OFFI	JUN23 CONTRACT	23060110
00-3-0101	OFFICE SUPPLIES	27.74	QUILL CORPORATION	INV 32241220	23060111

672-00 DRUG COURT *****
1,227.74

2390 DRUG COURT FUND *****
1,227.74

666-00	JUVENILE SERVICES AID PROGRAM GRANT				
00-1-0200	7 SALARIES	1,065.00	ANITA STOUGARD	PP END 5/16/23 MILEAGE	23060112
00-2-1704	7 MILEAGE	343.24	ANITA STOUGARD	PP END 5/16/23 MILEAGE	23060112

666-00 JUVENILE SERVICES AID PROGRAM GRANT *****
1,408.24

2516 JUVENILE SERVICES AID PROGRAM GRANT FUND *****
1,408.24

APS7040
5/19/23
16:05:39

SALINE
BOARD PREAPPROVAL REPORT
JUVENILE SERVICES AID PROGRAM GRA
FROM 06/02/2023 TO 06/02/2023

Account #	Description	Account Amt	Vendor	Invoice Description	Claim #
911-00	COVID AMERICAN RESCUE PLAN				
00-2-9900	7 COVID AMERICAN RESCUE PLAN	151,640.00	MMC MECHANICAL CONTRACTOR INV 61860		23060113
	911-00 COVID AMERICAN RESCUE PLAN	151,640.00			
	2580 COVID AMERICAN RESUCE PLAN FUND	151,640.00			
600-00	911 EMERGENCY MANAGEMENT FUND				
00-2-0200	TELEPHONE EXP (SURCHARGE)	250.46	WINDSTREAM	ACCT 090010615	23060115
00-2-2502	PROFESSIONAL FEES	714.15	GEOCOMM INC	INV037711	23060114
	600-00 911 EMERGENCY MANAGEMENT FUND	964.61			
	2910 911 EMERGENCY MANAGEMENT FUND FUND	964.61			
600-00	911 WIRELESS SERVICE FUND				
00-5-1217	911 WIRELESS SERVICE FUND	4,046.85	GEOCOMM INC	INV037711	23060116
00-5-1217	911 WIRELESS SERVICE FUND	1,106.95	WINDSTREAM	ACCT 090010615	23060117
	600-00 911 WIRELESS SERVICE FUND	5,153.80			
	2913 911 WIRELESS SERVICE FUND	5,153.80			
665-00	LAW ENFORCEMENT COMMISSARY				
00-2-1900	FOOD	4,590.75	SUMMIT FOOD SERVICE LLC	INV 2000173473 INV 20001734	23060120
00-2-9900	MISCELLANEOUS	403.14	BOB BARKER COMPANY INC	INV 1899936	23060118
00-2-9900	MISCELLANEOUS	3,634.99	LINCOLN JOURNAL STAR	#118-00019318	23060119
00-2-9900	MISCELLANEOUS	1,544.94	SUMMIT FOOD SERVICE LLC	INV 2000173473 INV 20001734	23060120
	665-00 LAW ENFORCEMENT COMMISSARY	10,173.82			
	2965 LAW ENFORCEMENT COMMISSARY FUND	10,173.82			

APS7040
5/19/23
16:05:39

SALINE
BOARD PREAPPROVAL REPORT
LAW ENFORCEMENT COMMISSARY
FROM 06/02/2023 TO 06/02/2023

Account #	Description	Account Amt	Vendor	Invoice Description	Claim #
900-00	COURTHOUSE BUILDING BONDS-DEBT SERV				
00-6-0200	INTEREST PAYMENTS	39,881.25	UNION BANK & TRUST	ACCT 2005082	23060121
00-6-0302	DEBT SERVICE INTEREST (MARKET	609.32-	UNION BANK & TRUST	ACCT 2005082	23060121

900-00	COURTHOUSE BUILDING BONDS-DEBT SERV	39,271.93			

3402	COURTHOUSE BUILDING-DEBT SERVICE FUND	39,271.93			

	GRAND	436,844.33			
