



STILLWATER BOARD OF EDUCATION
Tuesday, April 14, 2026

5:30 PM Regular Meeting
Stillwater Public Schools Administration Building
314 South Lewis Street
Stillwater, OK 74074

1. **Call to Order and Roll Call**
2. **Pledge of Allegiance**
3. **Introductory Items and Board of Education Reorganization:**
 - A. Review Official Certificate of Election Results
 - B. Administer Oath of Office to Elected Member for Board of Education Seat No. One (1) (Procedural)
 - C. Nomination, Discussion, and Vote for President of the Board of Education (Action)
 - D. Nomination, Discussion, and Vote for Vice President of the Board of Education (Action)
 - E. Vote to Authorize the President to Designate a Board member to serve as Executive Session Minutes Clerk (Action)
4. **Communications / Public Interest**
 - A. Recognitions
Miss Camp and Mrs. Webber will recognize two FCCLA State Champions!
 1. Emma Cantu, 11th grade
 2. Laura Bennett, 11th grade
 - B. Superintendent's Report
 - C. Board Communication
 - D. Public Comments - *Patrons who wish to address the Board of Education shall be required to submit form BED-E prior to the start of the meeting*
5. **Consent Agenda (Action)**

All of the following items, which concern reports and items of a routine nature normally approved at a board meeting, will be approved by one board vote, unless any board member desires to have a separate vote on any or all of these items. The consent agenda consists of the discussion, consideration, and approval of the following items:

 - A. March 10, 2026, Regular Meeting Minutes
 - B. Out of State Travel requests:
 3. Stillwater Junior High Choir is traveling to Branson, MO from May 16, 2026, to May 17, 2026, to expose students to other states' cultures.
 4. Stillwater Junior High and High School Pioneer Robotics is traveling to St. Louis, MO from April 20, 2026, to April 27, 2026, to compete in the VEX VRC Robotics Worlds competition.
 5. Stillwater Varsity Baseball is traveling to Springdale, AR on May 1, 2026, to play against Shiloh Christian School.
 - C. Approval of the Transfer and Summary of Activity Account Funds
 - D. Approval of the Activity Account Fundraising Projects
 - E. Approval of the Change Orders, Encumbrances, and Accounts Payable (approval of encumbrance numbers as listed):

2025-2026 Change Orders:

2025-2026 General Fund (11) Encumbrances #2026-11-784 - 2026-11-962 totaling \$436,955.63
2025-2026 Building Fund (21) Encumbrances #2026-21-5 - 2026-21-7 totaling \$343,036.45
2025-2026 Child Nutrition (22) Fund Encumbrances #2026-22-86 - 2026-22-88 totaling \$54,355.54
2025-2026 Bond (31) Fund Encumbrances #2026-31-6 - 2026-31-37 totaling \$132,003.25

2025-2026 Bond (32) Fund Encumbrances #2026-32-69 - 2026-32-76 totaling \$12,424.34

2025-2026 Bond (33) Fund Encumbrances #2026-33-274 - 2026-33-290 totaling \$139,989.63

- F. Approval of the Site Capacity Numbers (Quarterly April 1) — Educational Services
- G. Consider and Vote to Approve Willowbrook, Inc. use of CM Contingency and Allowances for the SPS Bond 2023 HS Phase I Construction Project
- H. Consider and Vote to Approve Willowbrook, Inc. use of Owner Contingency and Allowances for the SPS Bond 2023 HS Phase I & II, and High School Phase I Athletics Construction Project
- I. Consider and Vote to Authorize the Superintendent to Solicit Bids for the SPS Richmond Elementary and Skyline Elementary Security, Safety, and Finish Improvements Pursuant to the Competitive Bidding Act of 1974
- J. Consider and Vote to Approve Service Order No. 31R1 with 505 Architects for professional services, including preparation of construction documents for the SPS Richmond Elementary and Skyline Elementary Security, Safety, and Finish Improvement Projects
- K. Consider and Vote to Approve Service Order No. 32 with 505 Architects for professional services related to the Bond 2023 High School Athletics Phase I Demolition of the High School Football Building
- L. Consider and Vote to Declare Facilities, Child Nutrition, and Transportation Equipment as Surplus Property
- M. Consider and Vote to Approve the Resolution for Schools and Libraries Universal Services (E-Rate) for 2026-2027. This Resolution Authorizes Filing of the Form 471 Applications for Funding Year 2026-2027 and the Payment of the Applicant's Share upon Approval of Funding and Receipt of Services
- N. Approval of the following Stillwater Public School Contracts:

Fiscal Year 2026:

- 6. Finalsite Addendum

O. Fiscal Year 2027:

- 1. DocAccess
- 2. Finalsite

6. Business / Finance: Chief Financial Officer, Kristie Newby

- A. Receive and Vote to Approve or Not Approve the Treasurer's Report
- B. Consider and take action with respect to a Resolution fixing the amount of Combined Purpose General Obligation Bonds, Series 2026A to mature each year; fixing the time and place the Bonds are to be sold; designating a Registrar/Paying Agent and Disclosure Counsel; approving the Preliminary Official Statement and distribution thereof; ratifying and confirming continuing disclosure policies and procedures; authorizing the Clerk to give notice of said sale as required by law and approving other matters related to the issuance of said Bonds.
- C. Consider and take action with respect to a Resolution fixing the amount of General Obligation Building Bonds, Taxable Series 2026B to mature each year; fixing the time and place the Bonds are to be sold; designating a Registrar/Paying Agent and Disclosure Counsel; approving the Preliminary Official Statement and distribution thereof; ratifying and confirming continuing disclosure policies and procedures; authorizing the Clerk to give notice of said sale as required by law and approving other matters related to the issuance of said Bonds.
- D. Consider and take action with respect to a Resolution approving a Sublease Purchase Agreement pertaining to the acquisition and financing of improvements to school buildings and facilities; approving an Escrow and Paying Agent Agreement; approving the forms of Sublease Purchase Agreement, Ground Lease Agreement, Tax Regulatory Agreement, Continuing Disclosure Agreement, and Official Statement; approving other documents and certificates related thereto; and containing other provisions related thereto.

7. Operations: Assistant Superintendent, Bo Gamble

- A. Consider and Vote to Award Bids for the Stillwater Public Schools Bond 2023 Stillwater High School. Athletics Phase I Civil and Landscape Bid package to the Following Bidders:

B. Name	C. Description	D. Actual Bid
E. MK Excavation, LLC	F. Earthwork	G. \$496,750.00
H. Patriot Construction Services Inc.	I. Site Utilities	J. \$571,000.00
K. Timber Wolf Excavating, LLC.	L. Paving& Walks and Concrete Retaining Wall	M. \$565,000.00
N. AAA Landscaping Inc.	O. Landscape and Irrigation	P. \$284,713.97

Q. A Better Fence Construction & Landscaping	R. Fencing	S. \$58,800.00
T. United Turf & Track	U. Athletic Field	V. \$1,231,500.00

- W. Consider and Vote to Approve to Accept the Guaranteed Maximum Price (GMP) Proposed by Willowbrook, Inc. for the Stillwater Public Schools Bond 2023 Stillwater High School, Athletics Phase 1 Civil and Landscape Package
- X. Consider and Vote to Assign Bids to Willowbrook, Inc. for the Stillwater Public Schools Bond 2023 Stillwater High School, Athletics Phase 1 Civil and Landscape Package
- Y. Receive Bond 2023 Update

8. **Other Reports and Recommendations:**

- A. Discuss and Possible Motion to Approve the following Stillwater Public School Policies:

B. Policy	C. Name
D. CN	E. School Transportation
F. FFACA-R	G. Administering Medication to Students (Regulation)

9. **Proposed Executive Session to Discuss the Following:**

- A. Proposed executive session to discuss the employment of those employees listed on attached Exhibit A. 25 O.S. Section 307(B)(1)
- B. Evaluation of the Superintendent (a routine evaluation session that the Board may conduct monthly) Pursuant to Executive Session Authority – OKLA. STAT. tit. 25 sect 307(B)(1) and (7).
- 10. Vote to Convene or Not Convene in Executive Session (Action)
- 11. President's Acknowledgment of the Return of the Board to Open Session
- 12. Statement of Executive Session Minutes
- 13. Consider and Vote to Approve or Not Approve the Appointments, Resignations and Employment Recommendations Listed on Exhibit A of the Agenda (Action)
- 14. **Adjournment (Action)**

This agenda was posted on the inside of the front door (visible from outside the building) of the Administration Building (314 S. Lewis), and on the School District's website located www.stillwaterschools.com on April 13, 2026, at 4:00 p.m. Notice of this regular meeting was given to the Payne County Clerk on December 5, 2025, (Prior to the deadline of December 15, 2025).

STILLWATER BOARD OF EDUCATION



Tawni Hooten, Clerk

Oklahoma Certification Report

OFFICIAL CERTIFICATE OF VOTES
PAYNE COUNTY, OKLAHOMA
APRIL 7, 2026

STILLWATER PUBLIC SCHOOLS INDEPENDENT SCHOOL DISTRICT NO. 016
FOR OFFICE NO. 1 STILLWATER PUBLIC SCHOOLS

Precinct	NATHAN BRUBAKER	RACHEL DILLIN
NOBLE COUNTY PCT 520307	2	0
PAYNE COUNTY PCT 600002	20	45
PAYNE COUNTY PCT 600003	22	56
PAYNE COUNTY PCT 600004	29	113
PAYNE COUNTY PCT 600005	15	26
PAYNE COUNTY PCT 600006	22	62
PAYNE COUNTY PCT 600007	1	9
PAYNE COUNTY PCT 600008	15	52
PAYNE COUNTY PCT 600009	47	166
PAYNE COUNTY PCT 600010	22	101
PAYNE COUNTY PCT 600011	6	32
PAYNE COUNTY PCT 600012	7	11
PAYNE COUNTY PCT 600013	30	97
PAYNE COUNTY PCT 600014	0	0
PAYNE COUNTY PCT 600015	22	98
PAYNE COUNTY PCT 600016	39	125
PAYNE COUNTY PCT 600401	31	90
PAYNE COUNTY PCT 600402	21	88
PAYNE COUNTY PCT 600403	1	13
PAYNE COUNTY PCT 600404	21	14
PAYNE COUNTY PCT 600405	0	0
PAYNE COUNTY PCT 600407	11	14
PAYNE COUNTY PCT 600408	3	3
PAYNE COUNTY PCT 600409	5	4
PAYNE COUNTY PCT 600410	4	0

Oklahoma Certification Report

OFFICIAL CERTIFICATE OF VOTES
PAYNE COUNTY, OKLAHOMA
APRIL 7, 2026

STILLWATER PUBLIC SCHOOLS INDEPENDENT SCHOOL DISTRICT NO. 016
FOR OFFICE NO. 1 STILLWATER PUBLIC SCHOOLS

Precinct	NATHAN BRUBAKER	RACHEL DILLIN
PAYNE COUNTY PCT 600411	10	20
Total:	406	1,239

WE, THE DULY APPOINTED MEMBERS OF THE PAYNE COUNTY ELECTION BOARD, STATE OF OKLAHOMA, DO HEREBY CERTIFY THAT THE ABOVE AND FOREGOING IS A TRUE AND CORRECT NUMBER OF VOTES CAST IN THE ELECTION HELD ON 4/7/2026. RESULTS OF SAID ELECTION ARE SHOWN ABOVE. DATED AT STILLWATER, OKLAHOMA, THIS 10th DAY OF APRIL, 2026.

Thomas Walsh

CHAIRMAN

Dennis Berthoff

VICE-CHAIRMAN

Courtney Calism

SECRETARY





Stillwater Public Schools Administration
Building
314 South Lewis Street
Stillwater, OK 74074

Minutes of Regular Meeting

Tuesday, March 10, 2026 5:30 PM Central

Attendance Taken at 5:31 PM.

Marshall Baker: Present
Rachel Dillin: Absent
Roberta Douglas: Present
Gay Washington: Present
Clyde Wilson: Present

1. CALL TO ORDER AND ROLL CALL

President Douglas called the meeting to order. Board Clerk Tawni Hooten conducted a roll call and declared that a quorum was present to proceed.

2. PLEDGE OF ALLEGIANCE

President Douglas asked everyone in attendance to stand as she led the Pledge of Allegiance.

3. COMMUNICATIONS/PUBLIC INTEREST

A. Superintendent's Report

Superintendent Bridges highlighted various athletic achievements, including state titles in wrestling and swimming, and noted upcoming SMAC events listed on the district calendar:

- District Highlights:
 - Academics & Activities:
 - 3 Oklahoma Academic All-Staters for 2026 – Aiden Kim, William Lin, and Katherine Liu (+2 former Pioneers at OSSM)
 - SEVEN National Merit Finalists
 - SJHS 8th Grade Academic Team – 3rd at State
 - SMS at the OSSM Middle School Math Contest
 - Aditya Bikkina 1st place male in 7th grade
 - Olivia Zhang 1st place female in 7th grade
 - Aarv Vaghela 2nd place male in 6th grade
 - Ahron Cho 3rd place male in 6th grade
 - OKC pin-pong ball launcher engineering competition-9th graders:
 - Aaron Maxey and Landon Rogers for 1st place

- SHS Aviation participated in the Oklahoma High School Aviation State Championship, placed 9th (out of 102) and was awarded the Oklahoma Aviation Spirit Award
- Robotics and Stem participating in numerous competitions
- Artsapalooza
- Athletics: 2 State Championships in boys wrestling and also had other great placings at the state level – Boys Dual and Team and Individual titles to just name a few. Girls wrestling had a State-Runner Up. Swimming had a student Elias Mendez a two-time State Champion who has already signed to swim at the collegiate level and broken records in every event participated in.
- SEVEN FFA students who have earned the prestigious State FFA Degree, and lots of ag students showing during this time exhibiting animals
- SMAC (Stillwater Makes A Change) is happening- Lots of events and they are listed on numerous calendars including the District calendar
- Highland Park received the Synergy Award from United Way for raising the most money at any site
- SPEF (Stillwater Public Education Foundation) Taste of Stillwater
 - Stillwater Public Schools Enrollment Update

B. Board Communication

The board took a few moments to express the exciting activities and involvement throughout the district and community.

- “Kudos” to our three Ag Instructors for their hard work and dedication to students. Our program is full of local support who invest thousands of dollars in our students.
- Schools have done a great job on scheduling and master scheduling
- Discussions of the percentages of advanced course work, etc.
- Board Election will be held on April 7th. Everyone is encouraged to get out and vote

C. Public Comments - Patrons who wish to address the Board of Education shall be required to submit form BED-E prior to the start of the meeting

The following individuals completed the BED-E form and were approved to speak on the following topic:

1. Candice Kelley "The misuse of the isolation rooms in certain schools, and PBIS training certificates"
2. Kerry McNickle "Performing Arts Endowment Committee will host our first Artsapalooza Community Event at the SHS Performing Arts Center"
3. Carol Anderson "I represent the Stillwater League of Women Voters and wish to make a short presentation on what Sunshine Week represents and ask board members to sign a pledge to follow the federal Freedom of Information Act and Oklahoma law requiring Open Meetings and Open Records"

4. CONSENT AGENDA (Action)

All of the following items, which concern reports and items of a routine nature normally

approved at a board meeting, will be approved by one board vote, unless any board member desires to have a separate vote on any or all of these items. The consent agenda consists of the discussion, consideration, and approval of the following items:

A. Approval of the February 10, 2026, Regular Meeting Minutes

B. Out of State Travel Requests

1. Stillwater High School Varsity Softball is traveling to Shawnee Mission, KS from August 27, 2026, through August 29, 2026, to compete at a fastpitch softball invitational.

C. Approval of Transfer and Summary of Activity Account Funds

D. Approval of Change Orders, Encumbrances and Accounts Payable (approval of encumbrance numbers as listed):

2025-2026 Change Order (Bond 32) Encumbrances #2026-32-4 totaling \$19,009.09

2025-2026 General Fund (11) Encumbrances #2026-11-659-783 totaling \$343,363.48

2025-2026 Building Fund (21) Encumbrances #2026-21-3-4 totaling \$9,058.75

2025-2026 Child Nutrition Fund (22) Encumbrances#2026-22-78-85 totaling \$21,627.17

2025-2026 Bond 31 Fund Encumbrances #2026-31-35 totaling \$13,540.50

2025-2026 Bond 32 Fund Encumbrances #2026-32-66-68 totaling \$9738.37

2025-2026 Bond 33 Fund Encumbrances #2026-33-239 -2026-33-273totaling \$1,758,492.93

2025-2026 Sinking Fund 41 Encumbrances #2026-41-2 totaling
\$15,217,356.25

2025-2026 Gift Fund 81 Encumbrances #2026-81-14 totaling \$53,579.00

E. Approval of Activity Account Fundraising Projects

F. Approval of Annual Activity Fund Planning & Approval Packages

G. Approval of the "Contract for Audit of Public Schools 2025-2026 School Year" and audited by Jenkins & Kemper Auditing Firm.

H. Stillwater Public Schools Contracts:

1. Kansas State University (Student Teaching Affiliation Agreement)—Ed Services

I. Consider and Vote to Approve Willowbrook, Inc. use of CM Contingency and Allowances for the SPS Bond 2023 HS Phase I Construction Project

J. Consider and Vote to Approve Willowbrook, Inc. Use of Owner Contingency and Allowances for the SPS Bond 2023 HS Phase I Construction Project

K. Consider and Vote to Approve the Terms of Service Agreement and Addendum with Rocket Alumni Solutions, Inc.

L. Consider and Vote to Declare Equipment at Stillwater High School as Surplus Property

M. Consider and Vote to Approve Service Agreement for Firewall Renewal with OneNet

N. Consider and Vote to Approve the Cost - Share Agreement with the City of Stillwater

O. Consider and Vote to Approve Trafera Agreement for Student Device Lease Schedule 002

I move to approve the Consent Agenda as presented. This motion, made by Gay Washington and seconded by Clyde Wilson, **Carried**.

Marshall Baker: Yes, Roberta Douglas: Yes, Gay Washington: Yes, Clyde Wilson: Yes

5. BUSINESS/FINANCE, Chief Financial Officer, Kristie Newby

A. Receive and Vote to Approve or Not Approve the Treasurer's Report

I move to approve the Treasurer's report as presented. This motion, made by Marshall Baker and seconded by Gay Washington, **Carried**.

Marshall Baker: Yes, Roberta Douglas: Yes, Gay Washington: Yes, Clyde Wilson: Yes

6. OPERATIONS, Assistant Superintendent Bo Gamble

A. Consider and Vote to Award Contract for the Stillwater High School Athletics Phase I Fieldhouse Renovation Project:

<u>Contractor</u>	<u>Lump-Sum Base Bid Price</u>
Firebrand Construction	\$149,300.00
Hoey Construction	\$153,000.00
Ross Group	\$113,500.00
Thompson Construction	\$173,941.00
W.L. McNatt	\$154,555.00

A solicitation of bids was issued in accordance with Oklahoma Statutes. Bids were received, opened, and read aloud at 10:00 am on Wednesday, March 4, 2026.

Following a review of the bids received on March 4, 2026, Gay Washington moved to award the Interior Renovation Bid in the amount of \$113,500 to Ross Group for the Stillwater High School Athletics Phase I Fieldhouse Renovation Project as presented. This motion, made by Gay Washington and seconded by Marshall Baker, **Carried.**

Marshall Baker: Yes, Roberta Douglas: Yes, Gay Washington: Yes, Clyde Wilson: Yes

B. Receive Bond 2023 Update

Acting Superintendent of Operations, Bo Gamble provided the Bond 2023 Update to the board.

7. Discussion and Possible Motion to Acknowledge SPEF participating in the Oklahoma Equal Opportunity Scholarship Act.

I move to Acknowledge SPEF participating in the Oklahoma Equal Opportunity Scholarship Act. This motion, made by Marshall Baker and seconded by Clyde Wilson, **Carried.**

Marshall Baker: Yes, Roberta Douglas: Yes, Gay Washington: Yes, Clyde Wilson: Yes

8. Proposed Executive Session to Discuss the Following:

A. Proposed executive session to discuss the employment of those employees listed on attached Exhibit A. 25 O.S. Section 307(B)(1)

B. Evaluation of the Superintendent (a routine evaluation session that the Board may conduct monthly) Pursuant to Executive Session Authority – OKLA. STAT. tit. 25 sect 307(B)(1) and (7).

9. Vote to Convene in Executive Session (Action)

I move to convene into Executive Session at 6:32 p.m. This motion, made by Marshall Baker and seconded by Clyde Wilson, **Carried.**

Marshall Baker: Yes, Roberta Douglas: Yes, Gay Washington: Yes, Clyde Wilson: Yes

10. President's Acknowledgment of the Return of the Board to Open Session

President Douglas acknowledged the return of the board to open session at 8:10 p.m.

11. Statement of Executive Session Minutes

The following statement was provided by MARSHALL BAKER. The Executive Session convened at 6:30p.m. During the Executive Session, the following people were present: Roberta Douglas, Clyde Wilson, Gay Washington, and Marshall Baker (6:30 p.m. - 7:10, 7:20 p.m. - 8:10 p.m.). Mr. Tyler Bridges (6:30 p.m. - 7:10, 7:20 p.m. - 8:10 p.m.), and Dr. Trent Swanson (6:30 p.m.- 6:48 p.m.). In the Executive Session, the Board discussed the appointments, resignations, and employment recommendations listed on Exhibit A of the agenda as authorized by OKLA. STAT. tit. 25 Section 307(B)(1), and the evaluation of the Superintendent as authorized by OKLA. STAT. tit. 25 Section 307(B)(1) and (7). Nothing else was discussed in the Executive

Session. No votes were taken in the Executive Session. This will constitute the minutes of the Executive Session.

12. Consider and Vote to Approve or Not Approve the Appointments, Resignations and Employment Recommendations Listed on Exhibit A of the Agenda.

I move to approve the Appointments, Resignations and Employment Recommendations Listed on Exhibit A of the Agenda as presented. This motion, made by Gay Washington and seconded by Marshall Baker, **Carried.**

Marshall Baker: Yes, Roberta Douglas: Yes, Gay Washington: Yes, Clyde Wilson: Yes

13. ADJOURNMENT

A. Vote to Adjourn (Action)

I move to adjourn at 8:15 p.m. This motion, made by Clyde Wilson and seconded by Gay Washington, **Carried.**

Marshall Baker: Yes, Roberta Douglas: Yes, Gay Washington: Yes, Clyde Wilson: Yes

STILLWATER BOARD OF EDUCATION

Roberta Douglas, President

STILLWATER BOARD OF EDUCATION



Tawni Hooten, Board & Minutes Clerk

(SEAL)

These minutes were officially approved by the Stillwater Board of Education on April 14, 2026.



STILLWATER PUBLIC SCHOOLS OUT-OF-STATE TRAVEL APPLICATION

Instructions: The sponsor requesting out-of-state travel should complete this application in full one month in advance of the trip. A complete itinerary along with any other pertinent information should accompany this application. The sponsor should also have full knowledge that this application must have administrative and Board of Education approval before travel may commence.

The following criteria will be used in approving out-of-state travel:

1. Funding availability
2. Time and effort required to raise funds
3. Benefit of the program
4. Success at state contests
5. School time to be missed
6. Other reasons for justification of trip, i.e. lack of state competition, etc.

All travel must comply with Policy CN of the Stillwater Public Schools Policies and Procedures manual regarding out-of-state field trips.

Application Date: 3/4/26	Building: SJHS	Sponsor Name: Brandon Bowman	Organization Requesting Travel: SJHS Choir
Date(s) of Travel: Saturday, 5/16/26 - Sunday, 5/17/26		Number of Students Traveling: 32-36	Destination: Branson, MO
Purpose of Travel: List the purpose of the trip and how students will benefit from the travel. To expose students to other states cultures, team building and experience music performance in a professional setting.			
Method of Transportation (vehicles, drivers, bus companies, etc.): Activity Bus(es)			
Lodging (hotels, etc): Please provide name and address of hotels, etc. Stone Castle Hotel 3050 Green Mountain Dr. Branson, MO 65616			
Supervision: Give a list of people (school personnel or parents) who have committed to serve as sponsors for this trip.			
1. Brandon Bowman	2. Aprill Raines	3. Angela Gamble	
4. Kacie Fox	5.	6.	
7.	8.	9.	
Organizational History: What recent (five years or fewer) trip(s) has this organization taken out-of-state? May 2024 - Took Freshmen Choir members to Branson with SHS Choir. May 2025 - Took 8th & 9th Grade Choir members to Branson			

OUT-OF-STATE TRAVEL APPLICATION FUNDING INFORMATION

Instructions: The table below should include total costs in all categories including the cost of fuel, driver that will be reimbursed to the district. Please provide an answer to all questions or information sought below the table. If not applicable, please indicate using N/A.

Sources of Funds

Projected Costs		General Fund	Activity Fund	Booster	Individual	Other
Ground Transportation / Gas	\$					
Ground Transportation / Driver	\$					
Ground Transportation / Other	\$		550-2,06			
Air Transportation	\$					
Lodging	\$					
Food	\$					
Registration	\$					
Other – Explain Trip cost per kid	\$				\$300-35	

Are scholarships provided for students needing financial assistance? Yes No

If answer is yes, what is source of funding for scholarship? Fundraising and Donation Drive

If answer is no, provide reason. _____

Sponsor: Before travel may occur, emergency release forms for each student must be on file along with a complete travel roster and itinerary in the Stillwater Public Schools Activities Office. Itineraries should also be provided to each parent before departure.



Sponsor Signature

4 March 2026

Date

APPROVALS



Director of Athletics/Activities

3/10/26

Date



Building Principal

3-9-26

Date



Director of Transportation

3/10/2026

Date

Superintendent

Date

**OUT-OF-STATE TRAVEL APPLICATION
TRIP ITINERARY**

Date:	Itinerary:
5/16-5/17/26	Please see the attachment.

SJHS Choir Tentative Branson Itinerary

Saturday May 16, 2026

- 8:30 am Load the bus at SJHS
- 9:00 am Depart from SJHS
- 11:00 am - Lunch at McDonald's/Subway over Hwy 66 in Vinita, OK
- 11:45 am - Load the bus
- 11:50 am - Depart for Branson, MO
- 2:30 pm - Arrive at Branson, MO. Group will meet your Tour Manager and check into Stone Castle Hotel, 3050 Green Mountain Drive, Branson, MO 65616 and change into performance uniforms
- 3:35 pm - Load the bus at Hotel
- 3:45 pm Depart for an early dinner at the Fall Creek Steak & Catfish House. (4:00 pm)
Branson's home of the tossed roll has delighted locals and visitors alike with fast, Friendly service, steaks, catfish, burgers, chicken and a large selection of sides as well as their famous fresh melt in the mouth rolls.
- 4:55 pm Load the Bus
- 5:00 pm Depart for The Pepsi Legends Theatre.
- 5:15 pm Show choir clinic begins as soon as the stage is set.
- 6:15 pm Dress rehearsal begins.
- 7:00 pm Theatre begins seating tonight's audience
- 7:25 pm SJHS Choir takes center stage, pre-show performance starts. (20 min. performance)
- 8:00 pm Enjoy Legends In Concert

Performing at The Pepsi Legends Theater! Legends in Concert is one of the most historic and fun music shows in the world. This show has a cast of all-star entertainers that are family-friendly, and features awesome and talented celebrity impersonators whose energy brings the true essence of your favorite superstars to the stage.

- 10:00 pm Depart for your hotel.
- 10:15 pm Curfew/lights out

Sunday May 17, 2026

- 7:00-8:30 am Continental breakfast is served at the hotel.
- 8:30 am Check out of the hotel. Please collect all room keys at this time
- 8:45 am Load the bus
- 9:00 pm Depart for Silver Dollar City.
- 9:30 am Arrive at Silver Dollar City Theme Park main entrance. A lunch meal voucher is provided for Lunch.
- 2:30 pm Meet your chaperone at the gazebo. Get any snacks or souvenirs and the gift shop
- 3:00 pm Load the bus
- 3:05 pm Depart for home. (We will make a gas station stop on the way home for restrooms, snacks and drinks, but no formal dinner stop).
- 8:30 pm Arrive at SJHS South Lot.



STILLWATER PUBLIC SCHOOLS

OUT-OF-STATE TRAVEL APPLICATION

Instructions: The sponsor requesting out-of-state travel should complete this application in full one month in advance of the trip. A complete itinerary along with any other pertinent information should accompany this application. The sponsor should also have full knowledge that this application must have administrative and Board of Education approval before travel may commence.

The following criteria will be used in approving out-of-state travel:

1. Funding availability
2. Time and effort required to raise funds
3. Benefit of the program
4. Success at state contests
5. School time to be missed
6. Other reasons for justification of trip, i.e. lack of state competition, etc.

All travel must comply with Policy CN of the Stillwater Public Schools Policies and Procedures manual regarding out-of-state field trips.

Application Date: 3/23	Building: SJHS/SHS	Sponsor Name: Rebecca Palmatary	Organization Requesting Travel: Pioneer Robotics
Date(s) of Travel: 4/20-4/27		Number of Students Traveling: 12	Destination: St. Louis, MO
Purpose of Travel: List the purpose of the trip and how students will benefit from the travel. To compete at VEX VRC Robotics Worlds Competition			
Method of Transportation (vehicles, drivers, bus companies, etc.): SUV and Parents			
Lodging (hotels, etc): Please provide name and address of hotels, etc. TBD			
Supervision: Give a list of people (school personnel or parents) who have committed to serve as sponsors for this trip.			
1. Rebecca Palmatary	2. Daniel Holm	3. Angel Rodgers	
4. Chris Richards	5.	6.	
7.	8.	9.	
Organizational History: What recent (five years or fewer) trip(s) has this organization taken out-of-state? Annual World Competition (both SJHS and HS Dallas, TX) Signature Robotics Competitions (both SJHS and HS; Dallas, TX; Pikes Peak, CO; Wichita, KS)			

OUT-OF-STATE TRAVEL APPLICATION FUNDING INFORMATION

Instructions: The table below should include total costs in all categories including the cost of fuel, driver that will be reimbursed to the district. Please provide an answer to all questions or information sought below the table. If not applicable, please indicate using N/A.

Sources of Funds

Projected Costs		General Fund	Activity Fund	Booster	Individual	Other
Ground Transportation / Gas	\$ 500	X				
Ground Transportation / Driver	\$ 0					
Ground Transportation / Other	\$ 0					
Air Transportation	\$					
Lodging	\$ 5000				X	X
Food	\$ 1000				X	
Registration	\$ 5400		X		X	
Other – Explain	\$					

Are scholarships provided for students needing financial assistance? Yes No

If answer is yes, what is source of funding for scholarship? _____

If answer is no, provide reason. fundraising opportunities provided all year

Sponsor: Before travel may occur, emergency release forms for each student must be on file along with a complete travel roster and itinerary in the Stillwater Public Schools Activities Office. Itineraries should also be provided to each parent before departure.

Rebecca Palmiste
Sponsor Signature

3/23/2026
Date

APPROVALS

Damen C. Nelson Walter Howell
Director of Athletics/Activities

3/23/2026 3/24/2026
Date

Damen C. Nelson Walter Howell
Building Principal

3/23/2026 3/24/2026
Date

[Signature]
Transportation

3/23/2026
Date

[Signature]
Superintendent

3/23/2026
Date

**OUT-OF-STATE TRAVEL APPLICATION
TRIP ITINERARY**

Date:	Itinerary:
3/20	HS Travel to St Louis
3/21-3/24	High School Competition
3/24	HS Travel to Stillwater, SJHS Travel St. Louis
3/25-3/27	SJHS Competition
3/27	SJHS Travel to Stillwater



STILLWATER PUBLIC SCHOOLS

OUT-OF-STATE TRAVEL APPLICATION

Instructions: The sponsor requesting out-of-state travel should complete this application in full one month in advance of the trip. A complete itinerary along with any other pertinent information should accompany this application. The sponsor should also have full knowledge that this application must have administrative and Board of Education approval before travel may commence.

The following criteria will be used in approving out-of-state travel:

1. Funding availability
2. Time and effort required to raise funds
3. Benefit of the program
4. Success at state contests
5. School time to be missed
6. Other reasons for justification of trip, i.e. lack of state competition, etc.

All travel must comply with Policy CN of the Stillwater Public Schools Policies and Procedures manual regarding out-of-state field trips.

Application Date: 3/23/26	Building: HS	Sponsor Name: Billy Jones	Organization Requesting Travel: Stillwater Varsity Baseball
Date(s) of Travel: 5/1/26		Number of Students Traveling: 23	Destination: Shiloh Christian School - Springdale, AR
Purpose of Travel: List the purpose of the trip and how students will benefit from the travel. Varsity Baseball game vs. Shiloh Christian			
Method of Transportation (vehicles, drivers, bus companies, etc.): Activity Bus - Jerad Warlick is the driver			
Lodging (hotels, etc): Please provide name and address of hotels, etc. N/A			
Supervision: Give a list of people (school personnel or parents) who have committed to serve as sponsors for this trip.			
1. Bryce Scalf	2. Billy Jones	3. Zach Boydston	
4. Jeff Ventris	5. Jerad Warlick	6.	
7.	8.	9.	
Organizational History: What recent (five years or fewer) trip(s) has this organization taken out-of-state? - Spring Break 2026: Wichita, KS (baseball games vs. Kansas teams) - Spring Break 2024: Dallas, TX (baseball games vs. Texas teams) - Spring Break 2023: Gulf Shore, AL (baseball tournament vs. teams from Alabama, Mississippi) - Spring Break 2022: Phoenix, AZ (baseball tournament vs. teams from Arizona, Colorado)			

OUT-OF-STATE TRAVEL APPLICATION FUNDING INFORMATION

Instructions: The table below should include total costs in all categories including the cost of fuel, driver that will be reimbursed to the district. Please provide an answer to all questions or information sought below the table. If not applicable, please indicate using N/A.

Sources of Funds

Projected Costs		General Fund	Activity Fund	Booster	Individual	Other
Ground Transportation / Gas	\$430	100%				
Ground Transportation / Driver	\$120	100%				
Ground Transportation / Other	\$					
Air Transportation	\$					
Lodging	\$					
Food	\$116			100%		
Registration	\$					
Other – Explain	\$					

Are scholarships provided for students needing financial assistance? Yes No

If answer is yes, what is source of funding for scholarship? _____

If answer is no, provide reason. No cost to players or families

Sponsor: Before travel may occur, emergency release forms for each student must be on file along with a complete travel roster and itinerary in the Stillwater Public Schools Activities Office. Itineraries should also be provided to each parent before departure.

Sponsor Signature

3/23/20
Date

APPROVALS

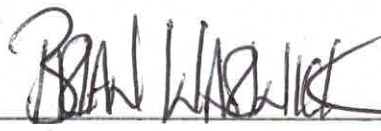
Director

3/24/20
Date

Walter R. Howell III
Building Principal

Date

Director of Transportation

3/25/2026
Date

Superintendent

Date

**OUT-OF-STATE TRAVEL APPLICATION
TRIP ITINERARY**

Date:	Itinerary:
5/1/26	12:00PM: Depart Couch Park Baseball Locker room for Springdale, AR
5/1/26	Estimate stop on way to destination (bathroom stops, snacks for players)
5/1/26	3:45PM: Estimated arrival at Shiloh Christian School, followed by warm-up and pre
5/1/26	5:00PM: Game start vs. Shiloh Christian
5/1/26	7:00PM: Game end
5/1/26	7:15PM: Eat dinner (at Shiloh Christian, provided by Dugout Club)
5/1/26	7:45PM: Depart Shiloh Christian
5/1/26	Estimate one stop on way back to Stillwater for restroom usage and snacks
5/1/26	11:00PM: Arrive at Couch Park



STILLWATER PUBLIC SCHOOLS
STILLWATER BOARD OF EDUCATION

PREPARED BY: Mrs. Kristie Newby, MBA, CFE, Chief Financial Officer
APPROVED BY: Tyler Bridges, Superintendent
DATE: April 14, 2026

AGENDA ITEM:

Transfer and Summary of Activity Account Funds

BOARD ACTION REQUESTED:

Motion to Approve Transfer and Summary of Activity Account Funds as Reconciled

BACKGROUND INFORMATION:

The activity fund transfer report reflects requested transfers of funds between sub-accounts as indicated.

The attached summary of individual site activity fund accounts reveals the name of the itemized accounts, opening balances, debits, credits, activity, and balances of the accounts year-to-date. All accounts are reconciled with bank statements at the closing of each week.

Request for Transfer of Funds between Activity Accounts

Date: 3/31/2026 School: Admin Bldg

Name of Requestor/Sponsor: Ronald McElliott

Signature of Requestor/Sponsor: 

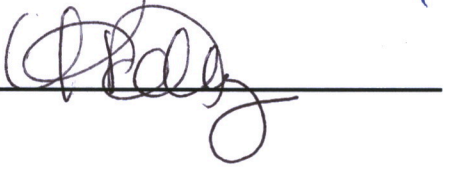
Approval of Supervisor/Principal : 

800 - Clearing/Sweep

814 - Human Resources

**Move from
Paying Account Name & No**

**Move to
Receiving Account Name & No**

Amount to be transferred: \$200

Reason for Moving funds:
To cover and additional 6 blankets for retirements.

TO BE COMPLETED BY DISTRICT ACTIVITY FUND CLERK

Date Approved by Board of Education: _____

Keep for Audit Records

Request for Transfer of Funds between Activity Accounts

Date: 3/24/2026 School: ADMINISTRATION BLDG

Name of Requestor/Sponsor: RONALD MCELLIOTT

Signature of Requestor/Sponsor: 

Approval of Supervisor/Principal: 

800 - CLEARING SWEEP
Move from
Paying Account Name & No

852 - SUNSHINE COMMITTEE
Move to
Receiving Account Name & No

Amount to be transferred: \$200.00

Reason for Moving funds:
TRANSFER PER SUPERINTENDENTS REQUEST TO ESTABLISH THE ADMIN BLDG
SUNSHINE COMMITTEE FUND

TO BE COMPLETED BY DISTRICT ACTIVITY FUND CLERK

Date Approved by Board of Education: _____

Keep for Audit Records

RECEIVED MAR 04 2026

Request for Transfer of Funds between Activity Accounts

Date: 3-4-26 School: Middle School

Name of Requestor/Sponsor: LEAH DOLLAR

Signature of Requestor/Sponsor: Leah Dollar

Approval of Supervisor/Principal: ~~Jackie Jackson~~ Jackie Jackson ^{3/4/26}

Robotics #932 @ SWS 505
Move from
Paying Account Name & No

Robotics #932 @ SWS 610
Move to
Receiving Account Name & No

Amount to be transferred: \$ 630

Reason for Moving funds:

OSU Football Stand Concessions Fundraising Dollars.
SWS = \$ 630
SWS = \$ 1,045
Deposited check on 3-3-26 for \$ 1,695.00

TO BE COMPLETED BY DISTRICT ACTIVITY FUND CLERK

Date Approved by Board of Education: _____

Keep for Audit Records

MAR 03 2026

Request for Transfer of Funds between Activity Accounts

Date: 3/12/26

School: MIDDLE SCHOOL

Name of Requestor/Sponsor: KYLE A. FERGUSON

Signature of Requestor/Sponsor: 

Approval of Supervisor/Principal: 

SPECIAL EVENTS ACCT #807

SMS AVIATION ACCT #841

Move from
Paying Account Name & No

Move to
Receiving Account Name & No

Amount to be transferred: 2,000.00

Reason for Moving funds:
MIDDLE SCHOOL FUNDRAISING FOR NEW START UP ACCOUNT FOR OUR NEW SMS AVIATION-STUDENTS & INSTRUCTORS

TO BE COMPLETED BY DISTRICT ACTIVITY FUND CLERK

Date Approved by Board of Education: _____

Keep for Audit Records

Request for Transfer of Funds between Activity Accounts

Date: 3/12/26

School: MIDDLE SCHOOL

Name of Requestor/Sponsor: KYLE A. FERGUSON

Signature of Requestor/Sponsor: 

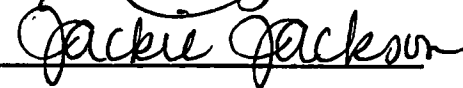
Approval of Supervisor/Principal: 

SPECIAL EVENTS ACCT#807

TSA ACCT#947

Move from
Paying Account Name & No

Move to
Receiving Account Name & No

Amount to be transferred: 1000.00

Reason for Moving funds:
MIDDLE SCHOOL TRANSFERRING OF FUNDS FOR FEE SHARING SPRING 2026 AND FALL 2026.

TO BE COMPLETED BY DISTRICT ACTIVITY FUND CLERK

Date Approved by Board of Education: _____

Keep for Audit Records

Request for Transfer of Funds between Activity Accounts

Date: 3-12-26

School: MIDDLE SCHOOL

Name of Requestor/Sponsor: KYLE A. FERGUSON

Signature of Requestor/Sponsor: *Kyle A. Ferguson*

Approval of Supervisor/Principal: *Jackie Jackson*

SPECIAL EVENTS ACCT #807

ART ACCT#904

**Move from
Paying Account Name & No**

**Move to
Receiving Account Name & No**

Amount to be transferred: 2000.00

Reason for Moving funds:

MIDDLE SCHOOL TRANSFERRING OF FUNDS FOR FEE SHARING SPRING 2026 AND FALL 2026.

.....
TO BE COMPLETED BY DISTRICT ACTIVITY FUND CLERK

Date Approved by Board of Education: _____

Keep for Audit Records

MAR 16 2026

Stillwater Public Schools

Revenue/Expenditure Summary

Options: Fund: 60, Date Range: 7/2/2025 - 6/30/2026

	Begin Balance	Receipts	Adjusting Entries	Payments	Cash End Balance	Unpaid POs	End Balance
800 CLEARING/SWEEP	\$141,990.51	\$85,139.46	\$0.00	\$27,932.43	\$199,197.54	\$6,094.99	\$193,102.55
801 STUDENT SUPPLIES	\$188,875.85	\$263,425.86	\$0.00	\$277,778.68	\$174,523.03	\$14,711.20	\$159,811.83
802 COURTESY/APPRECIATION FUND	\$7,743.17	\$2,755.00	\$0.00	\$948.70	\$9,549.47	\$1,309.36	\$8,240.11
803 LIBRARY	\$21,985.65	\$34,803.22	\$0.00	\$32,057.52	\$24,731.35	\$9,442.38	\$15,288.97
805 SITE GENERAL ACTIVITY FUND	\$45,466.03	\$31,144.05	\$0.00	\$27,629.49	\$48,980.59	\$12,316.20	\$36,664.39
806 FACILITY RENTALS	\$9,907.57	\$0.00	\$0.00	\$2,372.94	\$7,534.63	\$3,149.00	\$4,385.63
807 SPECIAL EVENTS	\$109,323.39	\$64,488.37	\$0.00	\$64,702.62	\$109,109.14	\$20,594.61	\$88,514.53
812 PARKING FEES	\$15,922.81	\$15,175.00	\$0.00	\$14,895.05	\$16,202.76	\$12,864.13	\$3,338.63
813 LOCKER	\$2,929.60	\$0.00	\$0.00	\$1,350.00	\$1,579.60	\$0.00	\$1,579.60
814 HUMAN RESOURCES	\$1,380.63	\$2,032.25	\$0.00	\$1,563.47	\$1,849.41	\$1,731.00	\$118.41
816 PIONEER PANTRY	\$34,514.35	\$7,363.71	\$0.00	\$18,226.86	\$23,651.20	\$6,100.00	\$17,551.20
817 PERFORMING ARTS CENTER	\$47,151.53	\$12,774.74	\$0.00	\$10,184.01	\$49,742.26	\$12,581.22	\$37,161.04
818 WORK KEYS	\$864.00	\$190.50	\$0.00	\$189.00	\$865.50	\$0.00	\$865.50
820 THANKS A LATTE CART	\$1,001.11	\$460.60	\$0.00	\$579.23	\$882.48	\$365.07	\$517.41
828 SPECIAL EDUCATION	\$29,636.85	\$3,018.00	\$0.00	\$9,434.47	\$23,220.38	\$17,316.16	\$5,904.22
829 TECHNOLOGY	\$2,672.95	\$0.00	\$0.00	\$1,901.77	\$771.18	\$621.00	\$150.18
830 PROFESSIONAL DEVELOPMENT	\$13,258.56	\$42,082.14	\$0.00	\$11,098.63	\$44,242.07	\$14,186.00	\$30,056.07
831 PIONEER BOOK BUS	\$4,621.55	\$6,500.00	\$0.00	\$0.00	\$11,121.55	\$1,500.00	\$9,621.55
832 GRADY LAMBERT MEMORIAL LIBRARY	\$6,292.18	\$1,250.00	\$0.00	\$2,284.26	\$5,257.92	\$0.00	\$5,257.92
833 AFTER SCHOOL PROGRAMS	\$25,966.26	\$3,200.00	\$0.00	\$2,993.23	\$26,173.03	\$3,904.45	\$22,268.58
834 AFTER SCHOOL CHILDCARE	\$379,472.97	\$368,671.85	\$0.00	\$178,107.04	\$570,037.78	\$86,944.02	\$483,093.76
835 TEACHER OF THE YEAR	\$856.35	\$2,500.00	\$0.00	\$232.90	\$3,123.45	\$2,320.68	\$802.77
836 SUPPORT EMPLOYEE OF THE YEAR	\$300.14	\$1,500.00	\$0.00	\$0.00	\$1,800.14	\$200.00	\$1,600.14
838 SUPERINTENDENT/BOE	\$8,448.62	\$17,794.03	\$0.00	\$7,541.20	\$18,701.45	\$9,766.58	\$8,934.87
839 STILLWATER PUBLIC EDUCATION FOUNDATION GRANTS	\$24,416.96	\$76,691.80	\$0.00	\$56,516.70	\$44,592.06	\$16,443.92	\$28,148.14
840 OPEN DOORS (INTERNATIONAL FAMILIES PROGRAM)	\$201.65	\$0.00	\$0.00	\$0.00	\$201.65	\$0.00	\$201.65
841 SMS AVIATION	\$0.00	\$661.25	\$0.00	\$260.00	\$401.25	\$369.00	\$32.25
843 FACILITIES DEPARTMENT	\$3,467.87	\$39.00	\$0.00	\$150.00	\$3,356.87	\$0.00	\$3,356.87
845 REFUGEE SCHOOL IMPACT (RSI)	\$3,996.49	\$0.00	\$0.00	\$0.00	\$3,996.49	\$0.00	\$3,996.49
846 PSO FUND	\$0.00	\$2,531.28	\$0.00	\$0.00	\$2,531.28	\$525.00	\$2,006.28
847 MEALS FOR STUDENTS	\$0.00	\$3,468.42	\$0.00	\$2,813.42	\$655.00	\$655.00	\$0.00
848 BREW CREW	\$23.69	\$0.00	\$0.00	\$0.00	\$23.69	\$0.00	\$23.69
850 GRANT	\$2,925.36	\$0.00	\$0.00	\$594.36	\$2,331.00	\$726.57	\$1,604.43
851 TEACHER GRANTS	\$2,119.21	\$0.00	\$0.00	\$0.00	\$2,119.21	\$0.00	\$2,119.21
854 SPS STAFF WELLNESS	\$17.52	\$0.00	\$0.00	\$0.00	\$17.52	\$0.00	\$17.52
856 DONATIONS	\$2,735.48	\$92.00	\$0.00	\$0.00	\$2,827.48	\$0.00	\$2,827.48
857 PTA DONATIONS	\$4,850.91	\$0.00	\$0.00	\$0.00	\$4,850.91	\$1,295.68	\$3,555.23
858 FRIENDS OF LINCOLN ACADEMY	\$8,489.98	\$31,987.26	\$0.00	\$6,043.27	\$34,433.97	\$17,612.80	\$16,821.17
859 SUPPORT OF HOMELESS STUDENTS DONATION FUND	\$4,175.99	\$3,168.01	\$626.34	\$0.00	\$7,970.34	\$7,500.00	\$470.34
860 CLASS OF 1963	\$1,853.00	\$0.00	\$0.00	\$0.00	\$1,853.00	\$0.00	\$1,853.00
865 CHROMEBOOK REPLACEMENT/REPAIR	\$2,288.58	\$69,577.00	\$0.00	\$14,492.43	\$57,373.15	\$459.21	\$56,913.94
874 ADVANCED ART	\$533.12	\$3,915.00	\$0.00	\$3,188.44	\$1,259.68	\$726.48	\$533.20
876 ART	\$956.32	\$2,279.00	\$0.00	\$2,626.32	\$609.00	\$51.18	\$557.82
878 POTTERY	\$1,764.90	\$4,380.00	\$0.00	\$4,850.93	\$1,293.97	\$94.19	\$1,199.78
880 SCIENCE	\$564.09	\$0.00	\$0.00	\$180.05	\$384.04	\$142.65	\$241.39
883 SPEECH & DRAMA	\$6,565.85	\$6,394.17	\$0.00	\$7,893.05	\$5,066.97	\$2,862.04	\$2,204.93
885 INSTRUCTIONAL	\$16,497.13	\$26,482.00	\$0.00	\$1,313.80	\$41,665.33	\$24,898.96	\$16,766.37
891 OPSRC CATALYST EDUCATION FUND	\$0.00	\$48,500.00	\$0.00	\$0.00	\$48,500.00	\$48,500.00	\$0.00
901 ACADEMIC TEAM	\$1,181.82	\$1,498.00	\$0.00	\$433.80	\$2,246.02	\$1,934.00	\$312.02
903 AFRICAN AMERICAN STUDENT ASSOCIATION	\$477.59	\$0.00	\$0.00	\$0.00	\$477.59	\$0.00	\$477.59
904 ART CLUB	\$2,238.74	\$908.00	\$0.00	\$2,767.08	\$379.66	\$0.00	\$379.66
905 BAND	\$125,168.81	\$113,669.66	\$0.00	\$102,970.37	\$135,868.10	\$34,440.12	\$101,427.98
906 BEST BUDDIES	\$633.15	\$500.00	\$0.00	\$722.20	\$410.95	\$79.96	\$330.99
907 BETA CLUB	\$6,498.17	\$7,754.62	\$0.00	\$6,418.86	\$7,833.93	\$2,226.08	\$5,607.85

Stillwater Public Schools

Revenue/Expenditure Summary

Options: Fund: 60, Date Range: 7/2/2025 - 6/30/2026

	Begin Balance	Receipts	Adjusting Entries	Payments	Cash End Balance	Unpaid POs	End Balance
909 BUSINESS PROFESSIONALS OF AMERICA	\$184.42	\$835.00	\$0.00	\$810.96	\$208.46	\$0.00	\$208.46
912 N/A	\$626.34	\$0.00	(\$626.34)	\$0.00	\$0.00	\$0.00	\$0.00
915 FCCLA	\$2,755.09	\$4,039.22	\$0.00	\$3,671.79	\$3,122.52	\$649.72	\$2,472.80
916 FFA	\$23,891.11	\$223,085.00	\$0.00	\$221,892.62	\$25,083.49	\$24,740.44	\$343.05
917 FRENCH CLUB	\$135.95	\$0.00	\$0.00	\$0.00	\$135.95	\$0.00	\$135.95
924 KEY CLUB	\$32.62	\$0.00	\$0.00	\$0.00	\$32.62	\$0.00	\$32.62
925 MOCK TRIAL	\$292.21	\$255.00	\$0.00	\$200.00	\$347.21	\$79.93	\$267.28
926 MU ALPHA THETA	\$1,125.48	\$0.00	\$0.00	\$0.00	\$1,125.48	\$0.00	\$1,125.48
927 NATIONAL HONOR SOCIETY	\$8,857.35	\$2,095.00	\$0.00	\$2,191.92	\$8,760.43	\$1,299.97	\$7,460.46
930 ORCHESTRA	\$38,951.60	\$45,103.97	\$0.00	\$39,311.70	\$44,743.87	\$17,197.86	\$27,546.01
931 Orchestra Booster Club	\$852.35	\$0.00	\$0.00	\$0.00	\$852.35	\$0.00	\$852.35
932 ROBOTICS	\$13,397.77	\$42,410.57	\$0.00	\$30,663.82	\$25,144.52	\$12,623.51	\$12,521.01
933 PINK OUT WEEK	\$0.00	\$16,107.12	\$0.00	\$16,107.12	\$0.00	\$0.00	\$0.00
934 PIONEER PEER PARTNERS	\$2,095.65	\$0.00	\$0.00	\$328.94	\$1,766.71	\$0.00	\$1,766.71
936 PLTW	\$1,730.55	\$1,275.00	\$0.00	\$1,086.82	\$1,918.73	\$1,417.23	\$501.50
937 RUNNING CLUB	\$783.87	\$0.00	\$0.00	\$0.00	\$783.87	\$0.00	\$783.87
938 SCIENCE CLUB	\$3,832.62	\$0.00	\$0.00	\$52.99	\$3,779.63	\$0.00	\$3,779.63
940 SIGN LANGUAGE CLUB	\$179.54	\$0.00	\$0.00	\$0.00	\$179.54	\$0.00	\$179.54
941 SMS SINGERS	\$11,987.57	\$10,110.99	\$0.00	\$8,853.98	\$13,244.58	\$665.00	\$12,579.58
942 SPANISH CLUB	\$859.60	\$0.00	\$0.00	\$0.00	\$859.60	\$0.00	\$859.60
944 SPECIAL EDUCATION TRANSITION	\$10,491.57	\$5,062.78	\$0.00	\$4,276.65	\$11,277.70	\$4,672.28	\$6,605.42
945 STILLWATER MAKES A CHANGE	\$114.94	\$113,967.23	\$0.00	\$8,169.40	\$105,912.77	\$998.91	\$104,913.86
946 STUDENT COUNCIL	\$12,514.82	\$9,062.00	\$0.00	\$7,207.36	\$14,369.46	\$4,825.80	\$9,543.66
947 TECHNOLOGY STUDENT ASSOCIATION	\$1,282.98	\$1,745.53	\$0.00	\$1,176.79	\$1,851.72	\$180.00	\$1,671.72
948 THEATER PERFORMANCE	\$83,300.36	\$44,077.18	\$0.00	\$22,564.15	\$104,813.39	\$29,314.09	\$75,499.30
949 VOCAL MUSIC	\$40,827.08	\$47,652.20	\$0.00	\$22,432.53	\$66,046.75	\$35,023.57	\$31,023.18
951 YEARBOOK	\$40,141.69	\$15,263.32	\$0.00	\$22,983.60	\$32,421.41	\$15,616.86	\$16,804.55
952 YOUNG DEMOCRATS CLUB	\$270.22	\$185.00	\$0.00	\$0.00	\$455.22	\$101.94	\$353.28
953 N/A	\$534.49	\$0.00	\$0.00	\$0.00	\$534.49	\$0.00	\$534.49
960 SR. CLASS OF 2028	\$2,030.00	\$2,300.00	\$0.00	\$0.00	\$4,330.00	\$0.00	\$4,330.00
961 SR. CLASS OF 2027	\$7,135.99	\$6,062.00	\$0.00	\$618.42	\$12,579.57	\$9,867.13	\$2,712.44
962 SR. CLASS OF 2026	\$7,502.75	\$1,873.00	\$0.00	\$0.00	\$9,375.75	\$6,128.34	\$3,247.41
964 ESPORTS CLUB	\$773.84	\$0.00	\$0.00	\$50.00	\$723.84	\$0.00	\$723.84
965 GENDER & SEXUALITY ALLIANCE (GSA)	\$269.72	\$0.00	\$0.00	\$0.00	\$269.72	\$111.73	\$157.99
970 ALL SPORTS	\$151,086.54	\$272,780.79	\$0.00	\$255,484.18	\$168,383.15	\$44,356.09	\$124,027.06
971 STADIUM CONCESSIONS	\$62,715.52	\$39,050.20	\$0.00	\$32,335.71	\$69,430.01	\$7,159.42	\$62,270.59
972 STATE PLAYOFFS	\$10,170.38	\$7,784.25	\$0.00	\$7,466.24	\$10,488.39	\$10,200.76	\$287.63
973 BASEBALL	\$0.26	\$0.00	\$0.00	\$0.00	\$0.26	\$0.00	\$0.26
974 BASKETBALL (BOYS)	\$1,129.00	\$0.00	\$0.00	\$0.00	\$1,129.00	\$516.26	\$612.74
975 BASKETBALL (GIRLS)	\$0.00	\$2,500.00	\$0.00	\$0.00	\$2,500.00	\$0.00	\$2,500.00
976 CHEERLEADERS	\$1,641.63	\$20,913.52	\$0.00	\$7,892.55	\$14,662.60	\$6,739.00	\$7,923.60
977 CROSS COUNTRY	\$7,629.99	\$0.00	\$0.00	\$400.00	\$7,229.99	\$0.00	\$7,229.99
978 FOOTBALL	\$2,778.73	\$3,238.00	\$0.00	\$3,669.00	\$2,347.73	\$1,782.00	\$565.73
979 GOLF (BOYS)	\$225.91	\$0.00	\$0.00	\$0.00	\$225.91	\$0.00	\$225.91
980 GOLF (GIRLS)	\$347.27	\$0.00	\$0.00	\$0.00	\$347.27	\$0.00	\$347.27
981 POM	\$10,158.10	\$1,517.00	\$0.00	\$7,293.24	\$4,381.86	\$3,509.80	\$872.06
982 SOCCER (BOYS)	\$7.70	\$0.00	\$0.00	\$0.00	\$7.70	\$0.00	\$7.70
983 SOCCER (GIRLS)	\$433.13	\$0.00	\$0.00	\$0.00	\$433.13	\$0.00	\$433.13
984 SWIMMING	\$1,579.60	\$500.00	\$0.00	\$720.05	\$1,359.55	\$326.25	\$1,033.30
985 TENNIS (BOYS)	\$1,875.78	\$0.00	\$0.00	\$0.00	\$1,875.78	\$0.00	\$1,875.78
986 TENNIS (GIRLS)	\$2,085.00	\$0.00	\$0.00	\$0.00	\$2,085.00	\$0.00	\$2,085.00
987 TRACK (BOYS)	\$2,673.00	\$0.00	\$0.00	\$0.00	\$2,673.00	\$0.00	\$2,673.00
988 TRACK (GIRLS)	\$2,768.00	\$0.00	\$0.00	\$0.00	\$2,768.00	\$0.00	\$2,768.00
989 VOLLEYBALL	\$516.50	\$50.00	\$0.00	\$175.00	\$391.50	\$0.00	\$391.50
990 WRESTLING	\$119.10	\$0.00	\$0.00	\$0.00	\$119.10	\$0.00	\$119.10
991 SOFTBALL	\$1,163.30	\$1,000.00	\$0.00	\$689.97	\$1,473.33	\$1,140.00	\$333.33
995 PIONEER PLAYDAY	\$190,633.90	\$58,364.09	\$0.00	\$8,809.40	\$240,188.59	\$82,292.00	\$157,896.59

Stillwater Public Schools

Revenue/Expenditure Summary

Options: Fund: 60, Date Range: 7/2/2025 - 6/30/2026

	Begin Balance	Receipts	Adjusting Entries	Payments	Cash End Balance	Unpaid POs	End Balance
996 L. ALLRED GOLF SCHOLARSHIP	\$20,500.00	\$1,000.00	\$0.00	\$21,500.00	\$0.00	\$0.00	\$0.00
997 W. WELCH WRESTLING SCHOLARSHIP	\$2,645.00	\$0.00	\$0.00	\$0.00	\$2,645.00	\$0.00	\$2,645.00
998 RAYMOND ESTES SCHOLARSHIP	\$5,895.60	\$0.00	\$0.00	\$0.00	\$5,895.60	\$0.00	\$5,895.60
999 MATT FOSTER MEMORIAL	\$830.00	\$0.00	\$0.00	\$0.00	\$830.00	\$0.00	\$830.00
Total	\$2,126,596.09	\$2,372,030.21	\$0.00	\$1,669,325.48	\$2,829,300.82	\$723,096.78	\$2,106,204.04



STILLWATER PUBLIC SCHOOLS
STILLWATER BOARD OF EDUCATION

PREPARED BY: Mrs. Kristie Newby, MBA, CFE, Chief Financial Officer
APPROVED BY: Tyler Bridges, Superintendent
DATE: April 14, 2026

AGENDA ITEM:

Annual Activity Account Fund Raising Projects for FY 2025-2026

BOARD ACTION REQUESTED:

Motion to Approve Annual Activity Account Fund Raising Projects for FY 2025-2026

BACKGROUND INFORMATION:

Fund Raising project bring additional revenue into activity accounts. They are typically approved on the accounts Annual Activity Fund Planning Packages. However, when fund raising projects become available throughout the year that are not listed on the accounts Annual Activity Fund Planning Packages, it must be presented to the Board for approval.

MAR 12 2026

STILLWATER BOARD OF EDUCATION

CFB-E1

FUNDRAISER REQUEST

Submit one copy per fundraiser (Due April 30 and November 30)

Reporting School Year: 2024 Sponsor Name: Emmy Wade

Name of Activity Fund: Pom Account No: 981

DESCRIPTION OF FUNDRAISER (INCLUDING ITEMS TO BE SOLD AND HOW):

Yard signs through Chris University Spirits

PURPOSE OF RAISING FUNDS:

New team expenses like uniforms, poms, etc

FUNDRAISER DATES: START 4/27 END 5/11

AMOUNT OF MONEY TO BE RAISED:

EST. INC. 120 - EST. EXP. \$0 = EST. PROFIT \$120

Emmy Wade SPONSOR SIGNATURE

ATHLETIC DIRECTOR AUTHORIZATION (applicable only if athletic fundraiser)

Danu Miller PRINCIPAL AUTHORIZATION

BOARD OF EDUCATION APPROVAL DATE

FUNDRAISER CLOSEOUT

START DATE: END DATE:

FUNDRAISER PROFIT

ACT. INC. - ACT. EXP. = ACT. PROFIT (Reconciles to Deposits) (Reconciles to fundraiser related POs) (Net Increase to acct. due to fundraiser)

RECEIPT BOOK #: TO

SPONSOR SIGNATURE

FINANCIAL SECRETARY SIGNATURE



STILLWATER PUBLIC SCHOOLS
STILLWATER BOARD OF EDUCATION

PREPARED BY: Mrs. Kristie Newby, MBA, CFE, Chief Financial Officer
APPROVED BY: Tyler Bridges, Superintendent
DATE: April 14, 2026

AGENDA ITEM:

Change Orders, Encumbrances, and Accounts Payable (approval of encumbrance numbers as listed)

BOARD ACTION REQUESTED:

Motion to Approve Encumbrance Clerk's report as of April 1, 2026

BACKGROUND INFORMATION:

This monthly report is highlighting changes to existing Purchase Orders and activity through April 1, 2026.

Change Order Listing

Options: Fund(s): GENERAL FUND, Year: 2025-2026, ReferenceDate: PO Date, Date Range: 2/18/2026 - 3/30/2026, PO Range: 53 - 619, Minimum Amount Change: \$10,000.00, Minimum Percentage Change: 25.00%, Include Negative Changes: False

PO No	Date	Vendor No	Vendor	Description	Amount	
53	07/01/2025	4989	QUADIENT LEASING USA, INC	DISTRICT POSTAGE	5,000.00	
	DISTRICT POSTAGE8/5/2025 reduced	11-028-2620-619-000-0000-000-050		08/05/2025	03/09/2026	-1,000.00
	po amount from \$18700.00 to	11-028-2620-619-000-0000-000-050		03/09/2026		309.41
	\$15,810.00 per email from Tina	11-028-2620-619-000-0000-000-050		03/09/2026		690.59
	8/5/2025					
	Increase PO by \$5,000 per Tina on	11-028-2620-619-000-0000-000-050		02/18/2026		5,000.00
	2/18/26					
619	01/12/2026	52433	RHONDA RINGER-RILEY	PIANO TUNING	200.00	
	Choir piano tuning March	11-066-1000-619-100-3000-000-705		01/12/2026	03/30/2026	-135.00
	2026**CHANGE ORDER INCREASE PO	11-066-1000-619-100-3000-000-705		03/30/2026		335.00
	BY \$200.00 TO ACCOMODATE					
	ADDITIONAL PIANO FEES					

Non-Payroll Total:	\$5,200.00
Payroll Total:	\$0.00
Report Total:	\$5,200.00

Project Totals		
028	POSTAGE & FREIGHT	5,000.00
066	PERFORMING ARTS CENTER	200.00

Unit Totals		
050	DISTRICT WIDE	5,000.00
705	STILLWATER HIGH SCHOOL	200.00

Change Order Listing

Options: Fund(s): BOND FUND 33, Year: 2025-2026, ReferenceDate: PO Date, Date Range: 3/30/2026 - 3/30/2026, PO Range: 125 - 267, Minimum Amount Change: \$10,000.00, Minimum Percentage Change: 25.00%, Include Negative Changes: False

PO No	Date	Vendor No	Vendor	Description	Amount	
125	07/01/2025	3684	RONALD W. THOMAS	REPAIRS TO INTERCOMS & DIGITAL CLOCKS	2,000.00	
				REPAIRS TO INTERCOMS & DIGITAL CLOCKS**CHANGE ORDER INCREASE FUNDS BY \$2000.00 TO COVER REMAINING EXPENSES FOR FY 25-26		
		33-054-2620-438-000-0000-000-050		07/01/2025	03/30/2026	-297.25
		33-054-2620-438-000-0000-000-050		03/30/2026		2,297.25
267	02/20/2026	4591	ULINE	STAIR CLIMBERS	24.76	
				STAIR CLIMBER FOR ULINE		
		33-092-2340-653-000-0000-000-050		02/20/2026	03/30/2026	-64.00
		33-092-2340-653-000-0000-000-050		03/30/2026		88.76
				ALUMINUM HAND TRUCKS**INCREASED AMOUNT BY \$24.76 AT APRIL 14, 2026 BOE MEETING (NO SHIPPING WAS INCLUDED ON ORIGINAL ENCUMBRANCE		

Non-Payroll Total:	\$2,024.76
Payroll Total:	\$0.00
Report Total:	\$2,024.76

Project Totals

054	BUILDING MAINTENANCE	2,000.00
092	TECHNOLOGY MISCELLANEOUS	24.76

Unit Totals

050	DISTRICT WIDE	2,024.76
-----	---------------	----------

Encumbrance Register

Options: Year: 2025-2026, Date Range: 7/1/2025 - 6/30/2026, PO Range: 784 - 962, Fund(s): GENERAL FUND

Fund	PO No	Date	Vendor	Description	Amount
GENERAL FUND	784	03/02/2026	SWIVL INC	LICENSING	224.50
GENERAL FUND	785	03/02/2026	K20 CENTER / UNIVERSITY OF OKLAHOMA	REGISTRATION	1,200.00
GENERAL FUND	786	03/02/2026	UNIVERSITY HOSPITALITY LLC	LODGING	220.00
GENERAL FUND	787	03/02/2026	CAMI J PATZKOWSKI	TRAVEL EXPENSES	150.00
GENERAL FUND	788	03/02/2026	KRISTENA J RUDLOFF	TRAVEL EXPENSES	150.00
GENERAL FUND	789	03/02/2026	SUSAN M MASTERS	TRAVEL EXPENSES	150.00
GENERAL FUND	790	03/02/2026	TAMMY C MATLOCK	TRAVEL EXPENSES	150.00
GENERAL FUND	791	03/03/2026	PROJECT LEAD THE WAY, INC.	CLASSROOM SUPPLIES STEM	3,163.75
GENERAL FUND	792	03/03/2026	B&H FOTO & ELECTRONICS CORP.	CLASSROOM TECHNOLOGY	2,168.63
GENERAL FUND	793	03/03/2026	ULINE	GENERAL SUPPLIES	2,081.70
GENERAL FUND	794	03/03/2026	AMAZON CAPITAL SERVICES	CLASSROOM EQUIPMENT	1,597.58
GENERAL FUND	795	03/03/2026	STUDIES WEEKLY	CONSUMABLE TEXTBOOKS	18,892.64
GENERAL FUND	796	03/05/2026	AMAZON CAPITAL SERVICES	SUPPLIES FAMILY ENGAGEMENT	616.69
GENERAL FUND	797	03/05/2026	OK CAREER TECH	PRINTING	213.00
GENERAL FUND	798	03/05/2026	OK CAREER TECH	PRINTING	219.00
GENERAL FUND	799	03/05/2026	OK CAREER TECH	PRINTING	120.00
GENERAL FUND	800	03/05/2026	APPLE, INC.	IPADS	6,000.00
GENERAL FUND	801	03/05/2026	BLACKMON MOORING OF OKC LLC	CARPET CLEANING	1,000.00
GENERAL FUND	802	03/05/2026	AMAZON CAPITAL SERVICES	SUPPLIES FAMILY ENGAGEMENT	2,416.79
GENERAL FUND	803	03/05/2026	AMERICAN PLANT PRODUCTS & SERV	SOIL	1,005.76
GENERAL FUND	804	03/05/2026	OSSBA	REGISTRATION BOARD MEMBER	300.00
GENERAL FUND	805	03/05/2026	AMAZON CAPITAL SERVICES	FASHION PRODUCTION SUPPLIES	203.10
GENERAL FUND	806	03/05/2026	PENDERS MUSIC COMPANY	FOLDERS FOR MUSIC STORAGE	245.00
GENERAL FUND	807	03/05/2026	THAMES & KOSMOS LLC	WIND POWER PACKS	560.91
GENERAL FUND	808	03/05/2026	STILLWATER MILLING COMPANY	CHEMICALS FOR GROUNDS	7,028.68
GENERAL FUND	809	03/05/2026	TEXAS AIR SALVAGE	AVIATION PROGRAM SUPPLIES	1,965.00
GENERAL FUND	810	03/05/2026	INTERWORKS, INC.	MONITORS	7,049.52
GENERAL FUND	811	03/05/2026	SHAR PRODUCTS COMPANY	ORCHESTRA INSTRUMENTS	1,715.77
GENERAL FUND	812	03/06/2026	TRAFERA HOLDINGS, LLC	EDUCATION INTERACTIVE	2,828.00
GENERAL FUND	813	03/06/2026	WILLIAM V. MACGILL & CO.	ELEMENTARY HEALTH SUPPLIES	103.10
GENERAL FUND	814	03/09/2026	AMAZON CAPITAL SERVICES	CLASSROOM SUPPLIES	1,284.51
GENERAL FUND	815	03/09/2026	CIMC-CCS	TWEEN LIFE TEACHER RESOURCE	300.00
GENERAL FUND	816	03/09/2026	ULINE	SAFETY VEST	326.68
GENERAL FUND	817	03/09/2026	SEAN BUCHANAN	PROFESSIONAL DEVELOPMENT	3,000.00
GENERAL FUND	818	03/09/2026	NULL EDUCATION SERVICES LLC	REGISTRATION/BLDG THINKING	1,200.00
GENERAL FUND	819	03/09/2026	AMAZON CAPITAL SERVICES	OFFICE SUPPLIES	22.79
GENERAL FUND	820	03/09/2026	LEXIA LEARNING SYSTEMS LLC	LETRS	2,640.00
GENERAL FUND	821	03/09/2026	FOLLETT CONTENT SOLUTIONS LLC	SHS LIBRARY BOOKS	1,680.80
GENERAL FUND	822	03/09/2026	LEXIA LEARNING SYSTEMS LLC	LETRS	33,998.00
GENERAL FUND	823	03/09/2026	PALEN MUSIC COMPANY	BAND SUPPLIES & REPAIRS	5,410.15
GENERAL FUND	824	03/10/2026	CHICKASAW TELECOM INC	TELEPHONE SERVICES	18,000.00
GENERAL FUND	825	03/10/2026	GLOWFORGE, INC	GLOWFORGE PRO HD	8,249.00
GENERAL FUND	826	03/10/2026	ZANER-BLOSER INC	KICKSTART NUMBER SENSE	9,020.00
GENERAL FUND	827	03/10/2026	AMAZON CAPITAL SERVICES	STEM SUPPLIES	1,795.17

Encumbrance Register

Options: Year: 2025-2026, Date Range: 7/1/2025 - 6/30/2026, PO Range: 784 - 962, Fund(s): GENERAL FUND

Fund	PO No	Date	Vendor	Description	Amount
GENERAL FUND	828	03/10/2026	FLINN SCIENTIFIC, INC.	STUDENT LAB EQUIPMENT	1,565.03
GENERAL FUND	829	03/10/2026	LOWE'S HOME IMPROVEMENT CENTER	CLASSROOM SUPPLIES-STEM	210.84
GENERAL FUND	830	03/10/2026	INFLUENTIAL DRONES LLC	AVIATION ACCESSORY	484.00
GENERAL FUND	831	03/11/2026	BLACKMON MOORING OF OKC LLC	WATER LEAK ABATEMENT	5,000.00
GENERAL FUND	832	03/11/2026	D AND G FENCE LLC	FENCING FOR HIGHLAND PARK	5,742.50
GENERAL FUND	833	03/11/2026	SOS SURVIVAL PRODUCTS INC	TEACHER EMERGENCY KITS	4,300.00
GENERAL FUND	834	03/11/2026	TEXAS SCOTTISH RITE HOSP. CHILDREN	TAKE FLIGHT	8,000.00
GENERAL FUND	835	03/11/2026	AMAZON CAPITAL SERVICES	POCKET FOLDERS	1,089.48
GENERAL FUND	836	03/11/2026	O'REILLY AUTOMOTIVE STORES, INC	TIRE MACHINE/BALANCER	6,570.00
GENERAL FUND	837	03/11/2026	TYLER TECHNOLOGIES INC	GPS WIRING HARNESES	241.00
GENERAL FUND	838	03/12/2026	KAJAL INN LLC	LODGING/MEI CONFERENCE	800.00
GENERAL FUND	839	03/12/2026	HERTZBERG-NEW METHOD INC	FY27 SEQUOYAH BOOKS	2,135.64
GENERAL FUND	840	03/12/2026	AMAZON CAPITAL SERVICES	PATHFINDERS	332.65
GENERAL FUND	841	03/16/2026	B & C BUSINESS PRODUCTS	OFFICE SUPPLIES	100.00
GENERAL FUND	842	03/16/2026	OK CAREER TECH	PRINTING	1,065.00
GENERAL FUND	843	03/16/2026	AMAZON CAPITAL SERVICES	ORGANIZATIONAL ITEMS	200.00
GENERAL FUND	844	03/16/2026	LOWE'S HOME IMPROVEMENT CENTER	SUPPLIES INDIGENOUS PEOPLE	400.00
GENERAL FUND	845	03/16/2026	WALMART LOCAL	ORGANIZATIONAL ITEMS	200.00
GENERAL FUND	846	03/16/2026	WOODBURN PRESS	PREVENTION & WELLNESS	2,171.23
GENERAL FUND	847	03/16/2026	JOURNEY HOUSE TRAVEL SERVICE INC	AIRFARE	1,418.00
GENERAL FUND	848	03/16/2026	VENTRIS LEARNING	TEACHER RESOURCES	354.75
GENERAL FUND	849	03/16/2026	OKLAHOMA FCCLA	FCCLA NLC JULY 6-10, 2026	220.00
GENERAL FUND	850	03/16/2026	NATIONAL FCCLA	REGISTRATION FCCLA NLC	630.00
GENERAL FUND	851	03/16/2026	UNIFORMS TODAY	FCCLA OFFICIAL BLAZERS	302.40
GENERAL FUND	852	03/16/2026	DEARINGERS PRINTING & TROPHY INC	BACK TO SCHOOL KIT	2,569.00
GENERAL FUND	853	03/16/2026	SCHOOL SPECIALTY LLC	PREVENTION & WELLNESS	967.60
GENERAL FUND	854	03/16/2026	AMAZON CAPITAL SERVICES	PREVENTION & WELLNESS	312.66
GENERAL FUND	855	03/16/2026	OSSBA	REGISTRATION	150.00
GENERAL FUND	856	03/16/2026	INSPIRE TO CREATE ENTERPRISES LLC	COUNSELING CURRICULUM	5,089.16
GENERAL FUND	857	03/16/2026	SCHOLASTIC BOOK FAIRS	BOOKS AND BAGS	4,261.68
GENERAL FUND	858	03/16/2026	RAM PRODUCTS CHEMICALS	DEGREASER	499.86
GENERAL FUND	859	03/16/2026	B & C BUSINESS PRODUCTS	TONER FOR PRINTER	364.38
GENERAL FUND	860	03/16/2026	B&H FOTO & ELECTRONICS CORP.	TELEVISION STAND	249.95
GENERAL FUND	861	03/16/2026	O'REILLY AUTOMOTIVE STORES, INC	TRANSPORTATION SUPPLIES	6,595.00
GENERAL FUND	862	03/16/2026	O'REILLY AUTOMOTIVE STORES, INC	TRANSPORTATION SUPPLIES	1,281.39
GENERAL FUND	863	03/16/2026	NATIONAL ARCHERY IN THE SCHOOLS	PE CLASS EQUIPMENT	270.00
GENERAL FUND	864	03/16/2026	AMAZON CAPITAL SERVICES	CLASSROOM SUPPLIES	272.26

Encumbrance Register

Options: Year: 2025-2026, Date Range: 7/1/2025 - 6/30/2026, PO Range: 784 - 962, Fund(s): GENERAL FUND

Fund	PO No	Date	Vendor	Description	Amount
GENERAL FUND	865	03/16/2026	UNIVERSITY OF CENTRAL OKLAHOMA	REGISTRATION/MEI CONF	475.00
GENERAL FUND	866	03/16/2026	HOBBY LOBBY	CLASSROOM SUPPLIES	300.00
GENERAL FUND	867	03/16/2026	WALMART LOCAL	CLASSROOM SUPPLIES	300.00
GENERAL FUND	868	03/16/2026	NATE'S TREE SERVICE, LLC	MULCH FOR HP	9,730.00
GENERAL FUND	869	03/24/2026	GRIMSLEY'S INC.	CHEMICAL DISPENSERS	4,050.00
GENERAL FUND	870	03/24/2026	B&H FOTO & ELECTRONICS CORP.	DELL MONITORS	328.34
GENERAL FUND	871	03/24/2026	SCHOOL SPECIALTY LLC	FACS CLASS SUPPLIES	794.27
GENERAL FUND	872	03/24/2026	WALMART LOCAL	FACS COOKING SUPPLIES	120.00
GENERAL FUND	873	03/24/2026	UNIFORMS TODAY	FCCLA UNIFORMS	269.78
GENERAL FUND	874	03/24/2026	AMAZON CAPITAL SERVICES	FACS CLASSROOM SUPPLIES	805.31
GENERAL FUND	875	03/24/2026	CHUDLEY EDWARD WERCH	TRAINING MATERIALS	3,424.08
GENERAL FUND	876	03/25/2026	NATIONAL GUARANTEED VINYL	SEAT COVERS	5,955.00
GENERAL FUND	877	03/25/2026	T & W TIRE LLC	TIRES & SUPPLIES	6,189.22
GENERAL FUND	878	03/25/2026	B & C BUSINESS PRODUCTS	OFFICE SUPPLIES	100.00
GENERAL FUND	879	03/25/2026	WALMART LOCAL	CLASSROOM SUPPLIES	680.00
GENERAL FUND	880	03/25/2026	FASTENAL COMPANY	NUTS & BOLTS	252.30
GENERAL FUND	881	03/25/2026	OK CAREER TECH	PRINTING	280.00
GENERAL FUND	882	03/25/2026	PLAYAWAY PRODUCTS LLC	AUDIO ENHANCED BOOKS	951.54
GENERAL FUND	883	03/25/2026	PROJECT WAYFINDER INC	SITE LICENSE & TRAINING	12,109.00
GENERAL FUND	884	03/25/2026	OK CAREER TECH	PRINTING	280.00
GENERAL FUND	885	03/25/2026	SOHA ELFEEL	TRAVEL EXPENSES/MEI CONF	68.00
GENERAL FUND	886	03/25/2026	MELISSA STIRLING-DURRANT	TRAVEL EXPENSES/MEI CONF	68.00
GENERAL FUND	887	03/25/2026	MAYA MOUKADDEM TAYBAH	TRAVEL EXPENSES/MEI CONF	68.00
GENERAL FUND	888	03/25/2026	Patricia Fox	TRAVEL EXPENSES/MEI CONF	68.00
GENERAL FUND	889	03/25/2026	AMAZON CAPITAL SERVICES	FURNITURE AND SUPPLIES	133.97
GENERAL FUND	890	03/25/2026	T & W TIRE LLC	TIRES & SUPPLIES	3,086.28
GENERAL FUND	891	03/25/2026	HERTZBERG-NEW METHOD INC	SHS LIBRARY BOOKS	1,012.78
GENERAL FUND	892	03/25/2026	B & C BUSINESS PRODUCTS	OFFICE SUPPLIES	75.00
GENERAL FUND	893	03/25/2026	AMAZON CAPITAL SERVICES	SUPPLIES FOR PCYS	1,692.57
GENERAL FUND	894	03/25/2026	AMAZON CAPITAL SERVICES	SUPPLIES FOR PCYS	7,000.00
GENERAL FUND	895	03/26/2026	GLOBAL VENDING GROUP	BOOKWORM VENDING	7,664.00
GENERAL FUND	896	03/26/2026	DEARINGERS PRINTING & TROPHY INC	ONBOARDING OFFICE SUPPLIES	2,300.50
GENERAL FUND	897	03/26/2026	GRIMSLEY'S INC.	AUTO SCRUBBERS	30,292.36
GENERAL FUND	898	03/26/2026	HAC INCORPORATED	FOOD LABS JH FACS	250.00
GENERAL FUND	899	03/26/2026	WALMART LOCAL	SCIENCE SUPPLIES	93.75
GENERAL FUND	900	03/26/2026	STILLWATER STEEL & SUPPLY, LLC	AG SHOP SUPPLIES	4,371.46
GENERAL FUND	901	03/26/2026	B-SEW INN LLC	SEWING MACHINES	1,461.00
GENERAL FUND	902	03/26/2026	B-SEW INN LLC	SEWING MACHINE REPAIR	159.20
GENERAL FUND	903	03/26/2026	QUAIL SPRINGS LODGING	LODGING/SMLF	3,000.00
GENERAL FUND	904	03/26/2026	VEX ROBOTICS, INC.	STEM CLASSROOM SUPPLIES	1,315.87
GENERAL FUND	905	03/26/2026	P & K EQUIPMENT, INC	MOWER SUPPLIES	600.00
GENERAL FUND	906	03/26/2026	KINNUNEN SALES & RENTALS	GROUNDS SUPPLIES	1,200.00
GENERAL FUND	907	03/26/2026	ATWOOD DISTRIBUTING L.P	GROUNDS SUPPLIES	220.00

Encumbrance Register

Options: Year: 2025-2026, Date Range: 7/1/2025 - 6/30/2026, PO Range: 784 - 962, Fund(s): GENERAL FUND

Fund	PO No	Date	Vendor	Description	Amount
GENERAL FUND	908	03/26/2026	CRISIS PREVENTION INSTITUTE, INC	MEMBERSHIP	200.00
GENERAL FUND	909	03/26/2026	CS&M ASSOCIATES	LODGING/ALTA CONFERENCE	4,500.00
GENERAL FUND	910	03/26/2026	JOURNEY HOUSE TRAVEL SERVICE INC	FLIGHTS/ALTA CONF	5,558.40
GENERAL FUND	911	03/26/2026	AMAZON CAPITAL SERVICES	LIBRARY BOOKS SKYLINE	139.41
GENERAL FUND	912	03/26/2026	CCOSA	TREASURER'S TRAINING	150.00
GENERAL FUND	913	03/27/2026	Ashley K Moore	TRAVEL EXPENSES/CCOSA LEAD	250.00
GENERAL FUND	914	03/27/2026	ASHLEY DOBBS	TRAVEL EXPENSES/CCOSA LEAD	250.00
GENERAL FUND	915	03/27/2026	Karetha L Bruns	TRAVEL EXPENSES/CCOSA LEAD	250.00
GENERAL FUND	916	03/27/2026	Rebecca A Dyson	TRAVEL EXPENSES/CCOSA LEAD	350.00
GENERAL FUND	917	03/27/2026	Jackie M Jackson	TRAVEL EXPENSES/CCOSA LEAD	250.00
GENERAL FUND	918	03/27/2026	AUSTIN L HULA	TRAVEL EXPENSES/CCOSA LEAD	350.00
GENERAL FUND	919	03/27/2026	REBEKAH T REECE	TRAVEL EXPENSES/CCOSA LEAD	160.00
GENERAL FUND	920	03/27/2026	AMAZON CAPITAL SERVICES	BOOK FOR LIBRARY	7.19
GENERAL FUND	921	03/27/2026	FOSSIL CREEK JOINT VENTURE LLC	LODGING/CONSCIOUS DISC	3,600.00
GENERAL FUND	922	03/27/2026	SCHOOL SPECIALTY SUPPLY	SUPPLIES FOR PCYS	3,271.42
GENERAL FUND	923	03/27/2026	RENAISSANCE HOTEL OPERATING CO.	LODGING/NLC	1,376.19
GENERAL FUND	924	03/27/2026	NORTHEASTERN STATE UNIVERSITY	REGISTRATION/APSI 2026	450.00
GENERAL FUND	925	03/27/2026	AMAZON CAPITAL SERVICES	SHS LIBRARY BOOKS	212.45
GENERAL FUND	926	03/27/2026	SPS TRANSPORTATION DEPT	TRANSPORTATION-STEM CAMP	320.00
GENERAL FUND	927	03/27/2026	SCHOLASTIC BOOK FAIRS	EL SUMMER READING PROGRAM	9,952.26
GENERAL FUND	928	03/27/2026	AVANT ASSESSMENT LLC	BILITERACY ASSESSMENTS	389.40
GENERAL FUND	929	03/27/2026	AMAZON CAPITAL SERVICES	TAKE FLIGHT MATERIALS	109.88
GENERAL FUND	930	03/27/2026	AMAZON CAPITAL SERVICES	BUILDING THINKING SUPPLIES	2,579.60
GENERAL FUND	931	03/27/2026	AMAZON CAPITAL SERVICES	SUPPLIES FOR ARCHERY COURSE	20.97
GENERAL FUND	932	03/27/2026	PRINCETON HEALTH PRESS	COUNSELING CURRICULUM	4,579.50
GENERAL FUND	933	03/27/2026	LOST MOUNTAIN COMMERCE LLC	TITLE I SPED SUPPLIES	4,349.95
GENERAL FUND	934	03/27/2026	SCI SUPPLY	TITLE I SCIENCE SUPPLIES	777.00
GENERAL FUND	935	03/27/2026	OK CAREER TECH	988 MESSAGE BOARD	350.00
GENERAL FUND	936	03/27/2026	PASCO SCIENTIFIC	TITLE I SCIENCE SUPPLIES	428.00
GENERAL FUND	937	03/27/2026	OK CAREER TECH	PRINTING EXPENSES	500.00
GENERAL FUND	938	03/27/2026	OK CAREER TECH	PRINTING EXPENSES	500.00
GENERAL FUND	939	03/27/2026	AMAZON CAPITAL SERVICES	EL SUMMER SCHOOL SUPPLIES	1,500.00
GENERAL FUND	940	03/27/2026	WALMART LOCAL	EL SUMMER SCHOOL SUPPLIES	500.00
GENERAL FUND	941	03/27/2026	SPS TRANSPORTATION DEPT	EL SUMMER SCHOOL TRANSPORTAION	4,122.00
GENERAL FUND	942	03/27/2026	AMAZON CAPITAL SERVICES	TITLE I SPED SUPPLIES	6,287.32
GENERAL FUND	943	03/27/2026	BLICK ART MATERIALS LLC	TITLE I ART SUPPLIES	14,382.14
GENERAL FUND	944	03/27/2026	AMAZON CAPITAL SERVICES	TITLE I ART SUPPLIES	2,403.40
GENERAL FUND	945	03/27/2026	THE HOUSE OF CLAY	TITLE I ART SUPPLIES	2,130.00
GENERAL FUND	946	03/27/2026	LOWE'S HOME IMPROVEMENT CENTER	TITLE I ART SUPPLIES	1,066.00
GENERAL FUND	947	03/27/2026	COYOTE CLAY & COLOR	TITLE I ART SUPPLIES	1,322.60
GENERAL FUND	948	03/27/2026	AMAZON CAPITAL SERVICES	TITLE I PE SUPPLIES	3,736.86

Encumbrance Register

Options: Year: 2025-2026, Date Range: 7/1/2025 - 6/30/2026, PO Range: 784 - 962, Fund(s): GENERAL FUND

Fund	PO No	Date	Vendor	Description	Amount
GENERAL FUND	949	03/27/2026	LOWE'S HOME IMPROVEMENT CENTER	TITLE I PE SUPPLIES	261.80
GENERAL FUND	950	03/27/2026	GOPHER SPORT	TITLE I SPED SUPPLIES	5,218.30
GENERAL FUND	951	03/27/2026	LAKESHORE LEARNING MATERIALS	TITLE I SPED SUPPLIES	2,075.74
GENERAL FUND	952	03/27/2026	AMAZON CAPITAL SERVICES	TITLE I SCIENCE SUPPLIES	359.90
GENERAL FUND	953	03/27/2026	CAROLINA BIOLOGICAL SUPPLY	TITLE I SCIENCE SUPPLIES	163.75
GENERAL FUND	954	03/27/2026	FLINN SCIENTIFIC, INC.	TITLE I SCIENCE SUPPLIES	11,430.39
GENERAL FUND	955	03/27/2026	HAC INCORPORATED	JH FACS FOOD LABS	215.00
GENERAL FUND	956	03/27/2026	AMAZON CAPITAL SERVICES	FACILITIES SUPPLIES	153.00
GENERAL FUND	957	03/27/2026	APPLE, INC.	IPADS FOR STUDENTS	433.00
GENERAL FUND	958	03/27/2026	WALMART LOCAL	OFFICE SUPPLIES	338.06
GENERAL FUND	959	03/30/2026	AMAZON CAPITAL SERVICES	SUPPLIES	187.64
GENERAL FUND	960	03/30/2026	AMAZON CAPITAL SERVICES	OFFICE STORAGE	217.55
GENERAL FUND	961	03/30/2026	COLLEGE BOARD	REGISTRATION/SUMMER AP	1,400.00
GENERAL FUND	962	03/30/2026	BARNES & NOBLE BOOKSELLERS INC.	LIBRARY BOOKS FOR JH	193.30

Non-Payroll Total:	\$436,955.63
Payroll Total:	\$0.00
Balance Forward:	\$0.00
Report Total:	\$436,955.63

Encumbrance Register

Options: Year: 2025-2026, Date Range: 7/1/2025 - 6/30/2026, PO Range: 5 - 7, Fund(s): BUILDING FUND

Fund	PO No	Date	Vendor	Description	Amount
BUILDING FUND	5	03/03/2026	ULINE	MOVING BOXES	1,036.45
BUILDING FUND	6	03/26/2026	CITY OF STILLWATER	UTILITY FEES	314,000.00
BUILDING FUND	7	03/26/2026	CLEARWATER ENTERPRISES, L.L.C.	NATURAL GAS UTILITY	28,000.00
Non-Payroll Total:					\$343,036.45
Payroll Total:					\$0.00
Balance Forward:					\$0.00
Report Total:					\$343,036.45

Encumbrance Register

Options: Year: 2025-2026, Date Range: 7/1/2025 - 6/30/2026, PO Range: 86 - 88, Fund(s): CHILD NUTRITION PROGRAMS FUND

Fund	PO No	Date	Vendor	Description	Amount
CHILD NUTRITION PROGRAMS FUND	86	03/06/2026	ACE MART RESTAURANT SUPPLY COMPANY	KITCHEN SMALL EQUIPMENT	5,380.54
CHILD NUTRITION PROGRAMS FUND	87	03/12/2026	VEND-UCATION LLC	CN EQUIPMENT	17,949.00
CHILD NUTRITION PROGRAMS FUND	88	03/16/2026	DIVERSIFIED FOODS INC	SHELF-STABLE MILK - SUMMER 2026	31,026.00
Non-Payroll Total:					\$54,355.54
Payroll Total:					\$0.00
Balance Forward:					\$0.00
Report Total:					\$54,355.54

Encumbrance Register

Options: Year: 2025-2026, Date Range: 7/1/2025 - 6/30/2026, PO Range: 36 - 37, Fund(s): BOND FUND 31

Fund	PO No	Date	Vendor	Description	Amount
BOND FUND 31	36	03/16/2026	THE ROSS GROUP CONSTRUCTION LLC	SPS HS ATHLETICS PHASE 1 FIELD HOUSE RENO PROJECT	113,500.00
BOND FUND 31	37	03/24/2026	KRUEGER INTERNATIONAL, INC.	ADMN CONFERENCE ROOMFURNITURE	18,503.25
Non-Payroll Total:					\$132,003.25
Payroll Total:					\$0.00
Balance Forward:					\$0.00
Report Total:					\$132,003.25

Encumbrance Register

Options: Year: 2025-2026, Date Range: 7/1/2025 - 6/30/2026, PO Range: 69 - 76, Fund(s): BOND FUND 32

Fund	PO No	Date	Vendor	Description	Amount
BOND FUND 32	69	03/03/2026	B&H FOTO & ELECTRONICS CORP.	CABLE CONCEALMENT RAMP	61.34
BOND FUND 32	70	03/11/2026	LOWE'S HOME IMPROVEMENT CENTER	TECHNOLOGY SUPPLIES	2,000.00
BOND FUND 32	71	03/11/2026	B&H FOTO & ELECTRONICS CORP.	TECHNOLOGY SUPPLIES	2,000.00
BOND FUND 32	72	03/11/2026	COLORADO TIME SYSTEMS	REPAIR HS SWIM SCOREBOARD	2,085.00
BOND FUND 32	73	03/11/2026	DUPREE SPORTS	MS TRACK UNIFORMS	2,650.00
BOND FUND 32	74	03/17/2026	DUPREE SPORTS	STUNT TEAM UNIFORM	1,100.00
BOND FUND 32	75	03/17/2026	DUPREE SPORTS	TENNIS UNIFORMS	2,028.00
BOND FUND 32	76	03/24/2026	MOSYLE CORPORATION	LICENSES	500.00
Non-Payroll Total:					\$12,424.34
Payroll Total:					\$0.00
Balance Forward:					\$0.00
Report Total:					\$12,424.34

Encumbrance Register

Options: Year: 2025-2026, Date Range: 7/1/2025 - 6/30/2026, PO Range: 274 - 290, Fund(s): BOND FUND 33

Fund	PO No	Date	Vendor	Description	Amount
BOND FUND 33	274	03/02/2026	BRIMAR INDUSTRIES LLC	CROSSWALK SIGNS	694.72
BOND FUND 33	275	03/02/2026	STILLWATER WINNELSON CO.	LIGHT WALL PACKS	3,250.00
BOND FUND 33	276	03/02/2026	INTERWORKS, INC.	PHONE BATTERIES	123.70
BOND FUND 33	277	03/05/2026	KNIGHTS ELECTRIC	LAA ELECTRICAL REPAIRS	1,577.65
BOND FUND 33	278	03/10/2026	INTERMOUNTAIN LOCK & SECURITY	COMBINATION LOCKS	11,880.46
BOND FUND 33	279	03/12/2026	B&H FOTO & ELECTRONICS CORP.	DOCKING STATION	3,641.60
BOND FUND 33	280	03/12/2026	THE REPAIR DEPOT LLC	CHROMEBOOK REPAIRS	459.21
BOND FUND 33	281	03/17/2026	CDW GOVERNMENT	GOOGLE WORKSPACE LICENSE	480.00
BOND FUND 33	282	03/24/2026	TECHNICAL SERVICES, INC.	FIRE SYSTEM REPAIR	1,323.92
BOND FUND 33	283	03/24/2026	UNITED SYSTEMS LLC	NETWORK HARDWARE AND SERVICES	1,403.20
BOND FUND 33	284	03/25/2026	AMAZON CAPITAL SERVICES	TECHNOLOGY SUPPLIES	112.81
BOND FUND 33	285	03/26/2026	SCHOOL SPECIALTY SUPPLY	12" WALL CLOCKS	3,336.45
BOND FUND 33	286	03/27/2026	PALEN MUSIC COMPANY	BAND INSTRUMENTS	100,203.70
BOND FUND 33	287	03/27/2026	XPRESSMYSELF.COM LLC	ASSET TAGS	2,068.00
BOND FUND 33	288	03/27/2026	AMERICAN ROOFING & CONSTRUCTION LLC	ROOF ACCESS LADDER	5,870.00
BOND FUND 33	289	03/27/2026	FARHA WHOLESALE CO	BATTERIES FOR AUTO SCRUBBER	2,510.00
BOND FUND 33	290	03/27/2026	SEON DESIGN USA CORP	DVR CAMERAS	1,054.21
Non-Payroll Total:					\$139,989.63
Payroll Total:					\$0.00
Balance Forward:					\$0.00
Report Total:					\$139,989.63



STILLWATER PUBLIC SCHOOLS

STILLWATER BOARD OF EDUCATION

PREPARED BY: Dr. Angela Rhoades, Assistant Superintendent

APPROVED BY: Mr. Tyler Bridges, Superintendent

DATE: April 1, 2026

AGENDA ITEM:

Quarterly Capacity Count

BOARD ACTION REQUESTED:

This is an information item only. No board action is requested.

BACKGROUND INFORMATION:

In accordance with (70 O.S. § 8-101.2), districts must establish, publish on their websites, and update quarterly capacity numbers for every grade level and school site, reporting them to the Oklahoma State Department of Education.

HIGHLAND PARK ELEMENTARY	CAPACITY	ENROLLMENT	AVAILABILITY - Out of District	AVAILABILITY - In District
Pre-K	40	40	0	0
Kindergarten	80	60	8	12
1st Grade	80	82	0	0
2nd Grade	80	64	6	10
3rd Grade	96	64	14	18
4th Grade	96	67	12	17
5th Grade	72	72	0	0
	544	449		
RICHMOND ELEMENTARY	CAPACITY	ENROLLMENT	AVAILABILITY - Out of District	AVAILABILITY - In District
Pre-K	40	39	0	1
Kindergarten	60	47	5	8
1st Grade	60	49	4	7
2nd Grade	60	64	0	0
3rd Grade	48	43	1	4
4th Grade	72	58	5	9
5th Grade	48	53	0	0
	388	353		
SANGRE RIDGE ELEMENTARY	CAPACITY	ENROLLMENT	AVAILABILITY - Out of District	AVAILABILITY - In District
Pre-K	60	52	3	5
Kindergarten	60	70	0	0
1st Grade	80	64	6	10
2nd Grade	80	82	0	0
3rd Grade	72	57	6	9
4th Grade	72	74	0	0
5th Grade	72	82	0	0
	496	481		
SKYLINE ELEMENTARY	CAPACITY	ENROLLMENT	AVAILABILITY - Out of District	AVAILABILITY - In District
Pre-K	40	36	1	3
Kindergarten	60	65	0	0
1st Grade	60	51	3	6
2nd Grade	60	53	2	5
3rd Grade	48	45	1	2
4th Grade	48	37	4	7
5th Grade	72	64	3	7
	388	351		
WESTWOOD ELEMENTARY	CAPACITY	ENROLLMENT	AVAILABILITY - Out of District	AVAILABILITY - In District
Pre-K	40	39	0	1
OS - Pre-K	20	7	5	8
Kindergarten	80	87	0	0
1st Grade	80	73	2	5
2nd Grade	80	84	0	0
3rd Grade	96	94	1	1
4th Grade	96	96	0	0
5th Grade	96	94	1	1
	588	574		
WILL ROGERS ELEMENTARY	CAPACITY	ENROLLMENT	AVAILABILITY - Out of District	AVAILABILITY - In District
Pre-K	60	54	1	2
Kindergarten	80	75	1	4
1st Grade	80	82	0	0
2nd Grade	60	72	0	0
3rd Grade	72	73	0	0
4th Grade	96	87	3	6
5th Grade	72	59	5	8
	520	502		
STILLWATER MIDDLE SCHOOL	CAPACITY	ENROLLMENT	AVAILABILITY - Out of District	AVAILABILITY - In District
6th Grade	450	406	44	0
7th Grade	490	465	25	0
	940	871		
STILLWATER JUNIOR HIGH SCHOOL	CAPACITY	ENROLLMENT	AVAILABILITY - Out of District	AVAILABILITY - In District
8th Grade	450	410	40	0
9th Grade	450	403	47	0
	900	813		

STILLWATER HIGH SCHOOL	CAPACITY	ENROLLMENT	AVAILABILITY - Out of District	AVAILABILITY - In District
10th Grade	525	484	41	0
11th Grade	450	412	38	0
12th Grade	450	421	29	0
	1425	1317		
Pre-K		272		
Kindergarten		404		
1st Grade		401		
2nd Grade		419		
3rd Grade		376		
4th Grade		419		
5th Grade		424		
6th Grade		406		
7th Grade		465		
8th Grade		410		
9th Grade		403		
10th Grade		484	includes 4 @ LA	
11th Grade		412	includes 25 @ LA	
12th Grade		421	includes 35 @ LA	
TOTAL		5716		



STILLWATER PUBLIC SCHOOLS
STILLWATER BOARD OF EDUCATION

PREPARED BY: Bo Gamble, Assistant Superintendent of Operations
APPROVED BY: Tyler Bridges, Superintendent
DATE: April 14, 2026

AGENDA ITEM:

Consider and Vote to Approve Willowbrook, Inc. use of CM Contingency and Allowances for the SPS Bond 2023 HS Phase I Construction Project.

BOARD ACTION REQUESTED:

Vote to Approve Willowbrook, Inc. use of CM Contingency and Allowances for the SPS Bond 2023 HS Phase I Construction Project.

BACKGROUND INFORMATION:

The attached report lists the requested use of CM contingency and allowances by Willowbrook, Inc. for the SPS Bond 2023 HS Phase I Construction Project.

The requests made in this agenda item do not impact the GMP.



CM Contingency Modification

0309c. - Stillwater New High School - Phase 2 PA Wing

Title: CMOD 3 - West Gym & City Gym Utility Disconnect

CM Contingency Modification : # 3

Date: 03/20/2026 **Date Required:**

Description of Work: This contingency modification is to cover costs associated with the plumbing contractor disconnecting MEP utilities at the West Gym and City Gym to allow demolition to proceed. These disconnects were not included in the demolition scope of work.

The below items will increase or decrease the contract scheduled value by the amounts listed below. Time in days indicates additional time required to project completion due to the changes referenced.

Item	Units	UM	Unit Price	Item Total	Bonds & Ins	Fee	Total	Time (In days)
1 : CMOD 3 - West Gym & City Gym Utility Disconnect	0.00	LS	0.00	- 19,288.0	0.0	0.00	- 19,288.00	
2 : Dense Mechanical	0.00	LS	0.00	19,288.0	0.0	0.00	19,288.00	

Total Change Amount: 0.00

Notes:

Approved By:

Shawn Vial

3/24/2026

Construction Manager:

Date:

WBJ

04/03/2026

Architect:

Date:

BA

4/6/26

Owner:

Date:



Date: 3/20/2026

Attn: Shawn Vick - Willowbrook

Re: Utilities Demo & Make Safe for Old gyms

Project: Stillwater HS PA Wing

Shawn, below is our proposed T&M cost in regard to Bid Package 1B:

Rates: \$160/hr for 2 tradesmen, \$220 for 3 tradesmen.

- Materials, equipment and labor cost subject to **10% OH&P Markup**

Scope of work:

- Utilities locate from 811 and coordination with service companies.
- Locate sewer line via camera & locator. Excavate, cap and backfill.
- Cut and remove concrete between City Gym and fieldhouse. Terminate domestic water and natural gas.
- Old gym north side – Cut concrete, excavate and terminate domestic water and natural gas.
- Gas riser and regulator on SW corner of Old gym, discovery of piping layout and equipment supplied by line. – This gas line is currently unlocatable and unknown what it feeds. Depending on how extensive this relocation is, we may go over our “Cost not to exceed” amount. A separate CO or extension to our amount may be required.

Total CO \$ 19,288.00 (see separate breakout)

Excludes- Work not outlined in scope of work, relighting of pilot lights from gas shutdown, concrete pouring.

Thank you for the opportunity. Please let me know if I can do anything else.

Aaron Bailey

Project Manager

Aaron.Bailey@DenseMechanical.com

C: (580) 478-5040

409 E. Broadway Avenue · Enid, OK 73701
580.234.7842 · www.DenseComfortSolutions.com
OKLIC#157904

Stillwater HS Utilities Demo
 Labor-Material-Equipment Breakout

Labor

Date	Labor Cost	Material Cost	Equipment Cost	
3/3/2026	\$ 2,200.00	\$ 675.00	\$ -	
3/4/2026	\$ 2,200.00	\$ -	\$ -	600.00 Locator/concrete saw/jackhammer one time charge
3/5/2026	\$ 2,255.00	\$ -	\$ -	
3/6/2026	\$ 1,980.00	\$ 393.00	\$ 3,000.00	Mini Ex one time charge
3/10/2026	\$ 1,040.00	\$ 91.00	\$ -	
3/19/2026	\$ 800.00	\$ -	\$ -	
Future date	\$ 2,200.00	\$ 100.00	\$ -	
Totals	\$ 12,675.00	\$ 1,259.00	\$ 3,600.00	

Total before Markup \$ 17,534.00

Total after 10% markup 19,288.00

TIME & MATERIAL DAILY LOG

Project:	Stillwater High	Location:	
Date:	3-3-26	Weather:	Fair
Start Time:	6 AM	End Time:	4:30 PM

Employee	Hours Worked	Equipment Used
Dusty Meyer	10	
Kyle Fritz	10	
Wyatt Lindberg	10	

Daily Progress

Saw cut and Jackhammered concrete north of west building. dug up water line and gas line to cap. will need to do more chiseling on gas line.

located 0.2" gas line that cut south of west building. seems to run from there north and around building to 4" into building. Still need to verify if it is feeding ~~any~~ any other buildings.

located gas line for west building just north of building running west to east. dug up a spot to rep. waiting to cut over we shut water down

Signature: Dusty Meyer
 Date: 3-3-26

Signature: _____
 Date: _____



4699

TIME & MATERIAL DAILY LOG

Project:	Stillwater High	Location:	Gym
Date:	3-4	Weather:	rainy/cloudy
Start Time:	6 AM	End Time:	4:30 PM

Employee	Hours Worked	Equipment Used
Wesley Meyer	10	
Kyle Frenz	10	
Wyatt Lindberg	10	

Daily Progress

ran locator down sewer in north bathrooms of gym to find sewer outside. sewer ran straight out East side and tapped into side cut manhole, dug up line and is ready for cut.

cut and Jackhammered concrete in bronze way just south of gym. found gas and water. will need to do more investigating on sewer for south side of gym

Signature: Wesley Meyer
 Date: 3-4-26

Signature: _____
 Date: _____



TIME & MATERIAL DAILY LOG

Project:	Skill water 1.1y	Location:	
Date:	3-5-26	Weather:	Good
Start Time:	6 AM	End Time:	4:45 PM

Employee	Hours Worked	Equipment Used
Dusty Meyer	10.25	
Wyatt Lindberg	10.25	
Kyle Frantz	10.25	

Daily Progress

Locate sewer coming up of East side of East gym
 Jackhammer the concrete in a spot to get ready to dig.
 Sewer is 7' deep so with bring out mixer ex to dig
 tomorrow.

did more investigating on gas line that runs west of west
 gym and found that it also feeds two other buildings so
 had to dig up gas line on north side of west gym
 for future cap.

Signature: *Dusty Meyer*
 Date: 3-5-26

Signature: _____
 Date: _____



TIME & MATERIAL DAILY LOG

Project:	Stillwater High	Location:	Old Gym
Date:	3-6-26	Weather:	Fair
Start Time:	6 AM	End Time:	3:30 PM

Employee	Hours Worked	Equipment Used
Dusty Meyer	9	Mini ex
Wyatt Lindberg	9	3- 4" Ferroc cap
Kyle Frantz	9	1- 6" Ferroc cap
		1- 6x4 PVC Reducer
		1- 4" Mega press cap

Daily Progress

got mini ex back to east side of gym and got sewer dug up, cut the sewer and capped
 capped sewer coming out of ~~east~~ North side of east gym at Manhole.
 Cost 6" clay tile sewer north of East Gym that fed the west gym and got capped.
 Shut off gas that was feeding west gym and cheer and capped off 4" line that was feeding. Will still have to get with school to turn back on so they can check other buildings.

Signature: 
 Date: _____

Signature: _____
 Date: _____



TIME & MATERIAL DAILY LOG

Project:	Stillwater Hwy	Location:	
Date:	3-10-26	Weather:	Fair
Start Time:	6	End Time:	1

Employee	Hours Worked	Equipment Used
Dusty Meyer	7	1-2" Poly cap
Wyatt Lindborg	6	

Daily Progress

Capped off 2" Gas line that was feeding east from
 Gas was coming in on S&D Sid next to water
 and sewer. backfilled that hole and marked both lines
 with pipe markers.
 Also marked the three other sewer caps with pipe markers
 will have to come back to cap water in two locations
 and backfill remaining holes

Signature: *Dusty Meyer*
 Date: 3-10-26

Signature: _____
 Date: _____



TIME & MATERIAL DAILY LOG

Project:	Stillwater HS	Location:	
Date:	3-19-2026	Weather:	Fair
Start Time:	6:00 am	End Time:	11:00 am

Employee	Hours Worked	Equipment Used
Kyle Frantz	5	Mini ex
Wyatt Lindberg	5	

Daily Progress

Backfilled exposed sewer and gas lines. Moved excess dirt & concrete away from gym to make room for asbestos removal contractors.

Signature: ABaly
 Date: 3-19-2026

Signature: _____
 Date: _____





CM Contingency Modification

0309b. - Stillwater New High School

Title: CMOD 31 - RFI 259 Overflow Drain Pit

CM Contingency Modification : # 31

Date: 03/18/2026 Date Required:

Description of Work: This contingency modification covers the costs associated with providing and installing a concrete area inlet to accommodate the elevation of the overflow drain, as outlined in RFI 259.

The below items will increase or decrease the contract scheduled value by the amounts listed below. Time in days indicates additional time required to project completion due to the changes referenced.

Item	Units	UM	Unit Price	Item Total	Bonds & Ins	Fee	Total	Time (In days)
1 : CMOD 31 - RFI 259 Overflow Drain Pit	0.00	LS	0.00	- 4,823.0	0.0	0.00	- 4,823.00	
2 : D Owen	0.00	LS	0.00	4,823.0	0.0	0.00	4,823.00	

Total Change Amount: 0.00

Notes:

Approved By:

Shawn Veal

3/24/2026

Construction Manager:

Date:

WBJ

04/03/2026

Architect:

Date:

BA

4/6/26

Owner:

Date:



Change Order #7

Project:
 24-016 STILLWATER HS
 UTILITIES
 Contract #0309b.005
 Contract Date: 6/21/2024

Customer:
 Willowbrook
 620 NE 36th St
 Oklahoma City OK 73105

Prepared By:
 Payte Owen
 Payte@dowenconstructionllc.com
 2/10/2026

1. Civil - Change Order 6 \$4,823.00

Description of Change:

*Supply and install area inlet and provide connection at overflow drains

<i>Item</i>	<i>QTY</i>	<i>Price</i>	<i>Subtotal</i>
Concrete Area Inlet (M,L,E)	1.00	\$2,640.00	\$2,640.00
Area Inlet Grate (M,L,E)	1.00	\$1,198.00	\$1,198.00
8" HDPE (M,L,E)	10.00	\$28.00	\$280.00
8" Inserta T (M,L,E)	1.00	\$705.00	\$705.00

Total Price: \$4,823.00

Original Contract Sum:	\$1,373,000.00
Net Change by Previously Authorized Change Orders:	\$310,505.00
Adjusted Contract Sum Prior to This Change Order:	\$1,683,505.00
Value of This Change Order:	\$4,823.00
Revised Contract Total:	\$1,688,328.00

We hereby agree to make the changes specified for Total Price listed above.

CONTRACTOR: _____
 D Owen Construction LLC

The above prices and specifications of this Change Order are satisfactory and are hereby accepted. All work shall be performed under the same terms and conditions as specified in the original contract unless otherwise stipulated.

ACCEPTED BY: _____
 Willowbrook

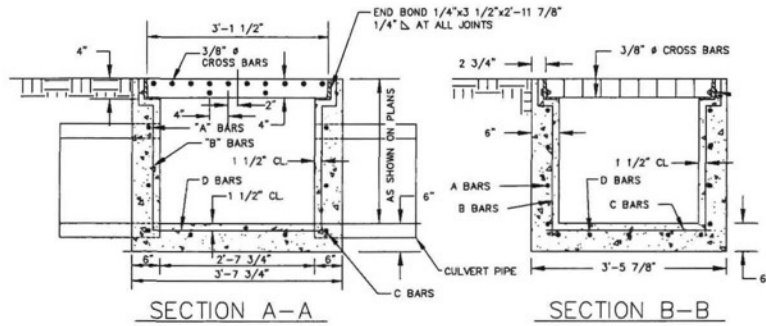

SECTION A-A

SECTION B-B

CONCRETE AREA INLET
NO SCALE

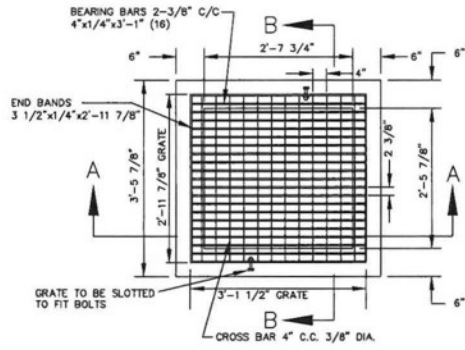

PLAN

HD-1-E-400 KERRIGAN WELDFORCED GRATING OR EQUAL
16 BEARING BARS @ 2 3/8" C/C-4" x 1/4" x 3'-1" LONG WITH
OVERALL DIMENSIONS 3'-1 1/2" x 2'-11 7/8" ARRANGED WITH
4" x 1/4" BEARING BARS 3'-1" LONG WITH END BANDING 3 1/2"
x 1/4" END BANDS 2'-11 7/8" LONG AND 3/8" CROSS BARS
SPACED 4" C/C AND CROSS BARS IN BOTTOM SPACED AS SHOWN.



CM Contingency Modification

0309b. - Stillwater New High School

Title: CMOD 32 - Sculpture Lab Stainless Steel Tops

CM Contingency Modification : # 32

Date: 03/18/2026 **Date Required:**

Description of Work: This contingency modification covers the costs associated with providing and installing all stainless steel countertops in Sculpture Lab 1158 that were not specifically included in any subcontractor's scope at the time of bid.

The below items will increase or decrease the contract scheduled value by the amounts listed below. Time in days indicates additional time required to project completion due to the changes referenced.

Item	Units	UM	Unit Price	Item Total	Bonds & Ins	Fee	Total	Time (In days)
1 : CMOD 32 - Sculpture Lab Stainless Steel Tops	0.00	LS	0.00	- 15,700.8	0.0	0.00	- 15,700.81	
2 : Amundsen	0.00	LS	0.00	15,700.8	0.0	0.00	15,700.81	

Total Change Amount: 0.00

Notes:

Approved By:

3/24/2026

Construction Manager:

Date:

04/03/2026

Architect:

Date:

4/6/26

Owner:

Date:



Quote

02/23/2026

Project:
Stillwater Public Schools High
School Phase 1 - Sculptors Lab

From:
Amundsen Commercial Kitchens -
OKC
Dustin Mihelis
3805 NW 36th st.
Oklahoma City, OK 73112
405-236-5961
405-236-5961 (Contact)

Job Reference Number: 20699

Item	Qty	Description	Sell	Sell Total
AC816	-3 ea	HAND SINK Jero Model No. CUSTOM Custom fabricated HAND SINK, shape and size per plans and specs. ***Refer to shop drawings***	\$936.23	\$-2,808.69
			ITEM TOTAL:	\$-2,808.69
AC816	3 ea	SS WORK COUNTER W/ HAND SINK Jero Model No. CUSTOM Custom fabricated SS Work Counter w/ Hand Sink & substrate, shape and size per plans and specs. (3ea. Locations, 1158 Sculptor Lab)	\$3,289.00	\$9,867.00
	3 lt	CUSTOM SS Wall Panels (3ea. Locations, 1158 Sculptor Lab)	\$1,782.50	\$5,347.50
			ITEM TOTAL:	\$15,214.50
SL	1 ea	SS COUNTER TOP Jero Model No. CUSTOM Custom fabricated SS Counter Top & substrate, shape and size per plans and specs. ***Refer to shop drawings***	\$1,495.00	\$1,495.00
			ITEM TOTAL:	\$1,495.00
INSTA LL EQUIP MENT	1 ea	CUSTOM FABRICATION INSTALLATION Amundsen Commerical Kitchens Model No. CUSTOM FABRICATION INSTALLATION Cost to deliver, uncrate, assemble and set in place food service custom fabrication provided by KEC and all applicable field welds. All final mechanical, electrical & plumbing connections are by		

Item	Qty	Description	Sell	Sell Total
		others.		
		EXCLUSIONS:		
		a. Removal or relocation of existing equipment that is not specified in Section 114000.		
		b. All final mechanical, electrical & plumbing connections for equipment in Section 11400, including but not limited to, walk-in(s), wiring inside and outside units for the walk-in(s), hood(s) and fire system(s), low voltage wiring to any equipment, power to disposer(s) & wiring from disposer(s) to switch(es), daisy chain connection of light(s) in walk-in(s).		
		c. Electrical conduit for walk-in(s) extending out to refrigeration units or for an alarm system.		
		d. Floor depressions.		
		e. Roof, wall, and floor penetrations or coring of building or slab.		
		f. Wall sleeves.		
		g. Wall blocking.		
		h. Roof jacks.		
		i. ALL CURBS, including roof curbs for remote refrigeration systems.		
		j. Concrete slab(s) for refrigeration system.		
		k. Cement and finished floor for walk-in cooler/freezer.		
		l. Under-slab conduit for refrigeration or beverage lines, or any other equipment		
			Installation: \$1,800.00	\$1,800.00
			Total	\$15,700.81

Acceptance: _____ Date: _____

Printed Name: _____

Project Grand Total: \$15,700.81



CM Contingency Modification

0309b. - Stillwater New High School

Title: CMOD 33 - Rise Classroom 1071 Safety Padding

CM Contingency Modification : # 33

Date: 03/20/2026 **Date Required:**

Description of Work: This contingency modification is to cover costs associated with providing and installing the wall safety pads in Rise Classroom 1071 that were not originally included in any subcontractor's scope at time of bid.

The below items will increase or decrease the contract scheduled value by the amounts listed below. Time in days indicates additional time required to project completion due to the changes referenced.

Item	Units	UM	Unit Price	Item Total	Bonds & Ins	Fee	Total	Time (In days)
1 : CMOD 33 - Rise Classroom 1071 Safety Padding	0.00	LS	0.00	- 3,647.4	0.0	0.00	- 3,647.39	
2 : SOPA	0.00	LS	0.00	3,647.4	0.0	0.00	3,647.39	

Total Change Amount: 0.00

Notes:

Approved By:

Shawn Veal

3/24/2026

Construction Manager:

Date:

WB

04/03/2026

Architect:

Date:

BA

4/6/26

Owner:

Date:



SOPA Inc
 241 Newman Drive
 North Little Rock, AR 72117

Change Order

Stillwater PS New HS - 25400253
Stillwater High School
410 West Franklin Lane
Stillwater, OK 74075

Change Order No. 2

Date: 03/12/2026
Sent By: Timothy Pawlicki
 tim@sopainc.com
 SOPA Inc

Respond By:
Sent To:

Change Reason:

Scope:

Title: Updated CO for Adding Wall Pads to Room 1071

Description: See itemized cost showing the following:

- 1. Additional wall pad material for pads as shown on A112 in Room 1071
- 2. Installation for wall pads
- 3. Mobilization
- 4. Bond

Schedule Impact:

Scope of Work

Item	Quantity	Unit Of Measure	Unit Price	Price Subtotal
Material	1	Lump Sum	\$2,785.95	\$2,785.95
Installation	1	Lump Sum	\$794.14	\$794.14
Mobilization	1	Lump Sum	\$911.79	\$911.79
Bond	1	Lump Sum	\$67.30	\$67.30
Price Subtotal:				\$4,559.18
Overhead:				
Total Price:				\$4,559.18 \$3,647.39

Review and Response

Approved Rejected Requested Revisions Other

 Timothy Pawlicki
 SOPA Inc



CM Contingency Modification

0309b. - Stillwater New High School

Title: CMOD 34 - Handrail Polished Concrete Patching

CM Contingency Modification : # 34

Date: 03/31/2026 Date Required:

Description of Work: This contingency modification covers the costs associated with patching the discolored polished concrete surrounding the stair handrails, which had to be installed after the initial concrete finish and resulted in the discoloration.

The below items will increase or decrease the contract scheduled value by the amounts listed below. Time in days indicates additional time required to project completion due to the changes referenced.

Item	Units	UM	Unit Price	Item Total	Bonds & Ins	Fee	Total	Time (In days)
1 : CMOD 34 - Handrail Polished Concrete Patching	0.00	LS	0.00	- 4,456.0	0.0	0.00	- 4,456.00	
2 : Concrete Color Systems	0.00	LS	0.00	4,456.0	0.0	0.00	4,456.00	

Total Change Amount: 0.00

Notes:

Approved By:

4/02/2026

Construction Manager:

Date:

04/03/2026

Architect:

Date:

4/6/26

Owner:

Date:

General Contractor: Willowbrook
Project Name: Stillwater HS
CCS Project Manager: Andrew Wilder
Date: 3.23.26
Requested By: Alexis Perez
Position: Asst. Superintendent
Signature of Approval: _____

Labor Burden 30%
Subtotal \$4,041
Overhead 5%
Subtotal \$4,243
Profit 5%
Subtotal \$4,456
Bond Cost
Total Cost \$4,456

\$584
\$4,041
\$202
\$4,243
\$212
\$4,456
\$4,456

PO Box 5429 • Pasadena • TX • 77508 • Office: 281.998.9451 • Fax: 281.998.9458 • www.concretecolorsystems.com



CM Contingency Modification

0309b. - Stillwater New High School

Title: CMOD 35 - RFI 278 - 1158C Countertop

CM Contingency Modification : # 35

Date: 04/01/2026 **Date Required:**

Description of Work: This contingency modification covers the costs associated with furnishing and installing the quartz countertop in Room 1158C, which was not included in any contractor's scope of work at the time of bid.

The below items will increase or decrease the contract scheduled value by the amounts listed below. Time in days indicates additional time required to project completion due to the changes referenced.

Item	Units	UM	Unit Price	Item Total	Bonds & Ins	Fee	Total	Time (In days)
1 : CMOD 35 - RFI 278 - 1158C Countertop	0.00	LS	0.00	- 3,909.4	0.0	0.00	- 3,909.40	
2 : Wood Systems	0.00	LS	0.00	3,909.4	0.0	0.00	3,909.40	

Total Change Amount: 0.00

Notes:

Approved By:

4/02/2026

Construction Manager:

Date:

04/03/2026

Architect:

Date:

4/6/26

Owner:

Date:



WOOD EST[®] 1988
SYSTEMS

Millwork/Casework Proposal

Date 03/30/26

To: CMS Willowbrook
 3108 South 9th Street

Ship To: Stillwater PS, New HS

Chickasha , OK 73018

Stillwater, OK

Phone (405) 224-5990
 Fax (405) 224-5995

Attention : n/a
 Project Desc. : Stillwater New HS Production
 Terms : n/a
 Delivery Date : n/a

Project Id : 24-0172
 Ship Via : Our Truck
 P.O. Number : n/a
 Salesperson : Scott Drevicky

Description	Selling Price
-------------	---------------

TOTAL	<u>\$ 0.00</u>
-------	----------------

Alternates / Change Orders / Exclusions

CO - RFI 278

DELIVERED MATERIAL

DELIVERED MATERIAL \$ 3,554.00

10% OH&P

10% OH&P \$ 355.40

CO - RFI 278 \$ 3,909.40

Please Note: Prices valid for 30 days.



STILLWATER PUBLIC SCHOOLS
STILLWATER BOARD OF EDUCATION

PREPARED BY: Bo Gamble, Assistant Superintendent of Operations
APPROVED BY: Tyler Bridges, Superintendent
DATE: April 14, 2026

AGENDA ITEM:

Consider and Vote to Approve Willowbrook, Inc. use of Owner Contingency and Allowances for the SPS Bond 2023 HS Phase I & II, and HS Phase I Athletics Construction Project

BOARD ACTION REQUESTED:

Vote to Approve Willowbrook, Inc. use of Owner Contingency and Allowances for the SPS Bond 2023 HS Phase I & II, and HS Phase I Athletics Construction Project

BACKGROUND INFORMATION:

The attached report lists the requested use of Owner Contingency and Allowances by Willowbrook, Inc. for the SPS Bond 2023 HS Phase I & II, and HS Phase I Athletics Construction Project.

The requests made in this agenda item do not impact the GMP.



Owner Contingency Modification

0310a. - Stillwater Public Schools HS Athletics Demolition Package

Title: OMOD 1 - PR 01 - Additional Demo Items

Owner Contingency Modification : # 1

Date: 03/31/2026 **Date Required:**

Description of Work: This following scope of work is included in this PCO:

1. Provide material, equipment and labor to perform the additional misc. demo scope of work outlined in PR 01.

The below items will increase or decrease the contract scheduled value by the amounts listed below. Time in days indicates additional time required to project completion due to the changes referenced.

Item	Units	UM	Unit Price	Item Total	Bonds & Ins	Fee	Total	Time (In days)
1 : OMOD 1 - PR 01 - Additional Demo Items	0.00	LS	0.00	- 10,920.0	0.0	0.00	- 10,920.00	
2 : Midwest Wrecking	0.00	LS	0.00	10,920.0	0.0	0.00	10,920.00	

Total Change Amount: 0.00

Notes:

Approved By:

4/02/2026

Construction Manager:

Date:

04/03/2026

Architect:

Date:

4/6/26

Owner:

Date:

MIDWEST
WRECKING
CO.

DEMOLITION

P.O. BOX 14668
OKLAHOMA CITY, OK 73113
OFFICE (405) 478-8833



COMMERCIAL & RESIDENTIAL
DEMOLITION



SITE CLEARANCE
DEBRIS REMOVAL

March 21, 2026

CMS Willowbrook
Attn: Shawn Vick
620 N.E. 36th Street
Oklahoma City, OK 73105
Phone: 600-9207 Fax: 600-9213

Re: PR-01
SPS Highschool Athletics, Stillwater

We propose and agree to furnish all labor, material, equipment, and insurance necessary to complete subject work, as described below:

Plan Sheet D101

1. Salvage plumbing fixtures.
2. Salvage toilet partitions.
3. Salvage the doors, levers and locksets.
4. Salvage wall signage and plaques.
5. The salvaged materials will be left on site to be re-installed by others.
6. Remove the flooring in the two bathrooms.

Plan Sheet D201

1. Salvage signage plaques.
2. Salvage plumbing fixtures.
3. Salvage toilet partitions.
4. Salvage doors, levers and lock sets.
5. The salvaged materials will be left on site to be re-installed by others.

Plan Sheet C201

- ~~1. Remove additional tree. —~~ -\$100.00

Plan Sheet C202 and C204

1. Inlets to remain.

This work will be completed for the sum of: **\$10,380.00** (Ten Thousand Three Hundred Eighty Dollars)

Plans Sheet 205

1. Demolish and remove chain link fencing.

This work will be completed for the sum of: **\$640.00** (Six Hundred Forty Dollars)

If you have any questions, please contact me at (405) 478-8833.

Sincerely,



Chris Kates
Vice President

Total = \$10,920.00



Owner Contingency Modification

0309b. - Stillwater New High School

Title: OMOD 105 - Electrical RFI's 266, 271, and 272

Owner Contingency Modification : # 105

Date: 03/18/2026 **Date Required:**

Description of Work: The following scope of work is included in this PCO:

1. Provide revised electrical circuitry in Welding 1123G to meet the welding outlet power requirements as outlined in RFI 266.
2. Revise lighting configuration in Nursing Area to ovoid overhead MEP obstructions as outlined in RFI 271.
3. Revise electrical circuitry to meet combination power requirements as outlined in RFI 272.

The below items will increase or decrease the contract scheduled value by the amounts listed below. Time in days indicates additional time required to project completion due to the changes referenced.

Item	Units	UM	Unit Price	Item Total	Bonds & Ins	Fee	Total	Time (In days)
1 : OMOD 105 - Electrical RFI's 266, 271, and 272	0.00	LS	0.00	- 7,046.0	0.0	0.00	- 7,046.03	
2 : Colburn Electric	0.00	LS	0.00	7,046.0	0.0	0.00	7,046.03	

Total Change Amount: 0.00

Notes:

Approved By:

3/24/2026

Construction Manager:

Date:

04/03/2026

Architect:

Date:

4/6/26

Owner:

Date:

Job ID: EW00541



Project: STILLWATER HIGH SCHOOL BUILDING

CO: 48: RFI 266 and 267

Takeoff

Phase: BRANCH

Item #	Qty	U/	Q/M	Size	Description	Material Result	Labor Result
TITLE	0.00	EA	M	3/4	Run additional conduit, Replace wire in		
10001	60.00	EA	M	3/4	EMT ON BAR JOIST MULTI RUN	0.00	0.00
20011	60.00	FT	M	3/4	EMT	53.18	4.25
20001	0.00	EA	M	3/4	EMT 90-ELBOW	0.00	0.00
30001	2.00	EA	M	3/4	EMT FIELD-BEND	0.00	0.58
630075	6.00	EA	M	3/4	EMT STEEL-SS COUPLING	3.70	0.40
30011	9.00	EA	M	3/4	COND HAMMER-ON HGR 1/4-FLNG SNP-CLOSE HD	25.91	0.77
40001	4.00	EA	M	3/4	EMT STEEL SS CONNECTOR	2.18	0.63
70035	0.00	EA	M	3/4	PLASTIC BUSHING	0.00	0.00
100032	420.00	FT	M	8	THIN/THWN CU (STR)	273.06	4.08
70229	3.00	EA	M	#18 to 8	WIRE-NUT MED -RED	0.62	0.32
100032	210.00	FT	M	10.	GREEN THHN CU (GRD 60A)	69.25	2.27
150041	1.00	EA	M	#18 to 8	WIRE-NUT MED -RED	0.21	0.11
150096	1.00	EA	M	2-1/8"D	1900 CMB-KO NO BRKT	2.86	0.32
630577	1.00	EA	M	1/4" FLANGE	1900 BLANK COVER	0.83	0.11
630505	6.00	EA	M	1/4" FLANGE	HAMMER-ON FLANGE CLIP - 1/4-20 x 3/8	12.67	0.38
161526	1.00	EA	M	1/4-20	COMB BOX & 1/2 > 3/4" SNP-CLS	13.07	0.39
160873	1.00	EA	M	1/4"	PLTD HEX NUTS	0.05	0.03
100053	1.00	EA	M	#12 SOL	PLTD FLAT WASHER	0.06	0.00
10517	1.00	EA	M	3/4	8" PIGTAIL W/GRD SCREW	0.76	0.11
740108	1.00	EA	M	3/4	CORED HOLE UP TO 8" D	0.00	1.75
180246	1.00	EA	M	50/2	FIRE STOP WALL/FLOOR SEAL LBR	3.00	1.35
	2.00	EA	M	50/2	BOLT-ON BREAKER	112.00	1.86

573.40

19.68

573.40

19.68

COLBURN ELECTRIC LLC

COLBURN ELECTRIC, LLC
829 W ELGIN
BROKEN ARROW, OK 74012

Phone: (918)

Web:

Date: 3/11/2026

BROKEN ARROW ELECTRIC SUPPLY

2350 WEST VANCOUVER
BROKEN ARROW, OK 74012
918-258-3581 OFFICE
918-258-5918 FAX

THIS QUOTE IS VALID FOR 30 DAYS

Company: COLBURN ELECTRIC

Job: STILLWATER HS - B ADDER

Attn: ED WEBBER

PAGE #1

Emily Long

E-MAIL elong@baes.com

It is the customer's responsibility to verify all fixture counts

THIS QUOTATION SUPERSEDES ALL PREVIOUS QUOTATIONS AND IS SUBJECT TO CHANGE WITHOUT NOTICE UNLESS OTHERWISE STATED.

ITEM NO.	QUANTITY	DESCRIPTION	PRICE	UNIT	TOTAL
B	2	6RN P6RDL20940WCCZ10U	\$262.67		\$525.34
		PLUS FREIGHT			
		LEAD TIME: 3-4 WEEKS ON MODULE			
			TOTAL		\$525.34

Quote #134-21008

10131 E 21ST ST.
TULSA, OK 74129
918-948-7825

ELLIOTT ELECTRIC SUPPLY

P.O. Box 206524, Dallas, TX 75320-6524
www.ElliottElectric.com



Customer Account: (1302280) **Ship To Information:** **Customer Phone:** 918-251-8765 **Customer Job/PO:** SHUNT TRIP
COLBURN ELECTRIC LLC 2552EW-STILLWATER HIGH SCHOOL
829 W ELGIN ST 410 W FRANKLIN
BROKEN ARROW, OK 74012 STILLWATER, OK 74075

• ATTENTION: Do Not Deliver From This Document!

Salesman: Bradford, Jerry **Quote Date:** 2/25/2026 **Date and Time Printed:** 2/25/2026 11:00:29 AM

Item Number	Quote Quantity	Catalog Number	Vendor Code	Description	Price	Unit Code	Extended Price
1	4	BAB1020S	ETN	BAB BRKR 1P 20A MAX 240V MAX 10K AIC	\$ 106.65	E	426.60

*Customer Item Information: 3 in stock at Elliott TULSA
B/O for 1, 5-7 days on stock order with no freight*

Total: \$ 426.60



Owner Contingency Modification

0309b. - Stillwater New High School

Title: OMOD 106 - Guidance Check-in 1034 Ceiling

Owner Contingency Modification : # 106

Date: 03/18/2026 **Date Required:**

Description of Work: The following scope of work is included in this PCO:

1. Install a dropped acoustical ceiling in Guidance Check-in 1034 to accommodate the Type B light fixtures.

The below items will increase or decrease the contract scheduled value by the amounts listed below. Time in days indicates additional time required to project completion due to the changes referenced.

Item	Units	UM	Unit Price	Item Total	Bonds & Ins	Fee	Total	Time (In days)
1 : OMOD 106 - Guidance Check-in 1034 Ceiling	0.00	LS	0.00	- 9,279.7	0.0	0.00	- 9,279.66	
2 : Wiljo	0.00	LS	0.00	886.0	0.0	0.00	886.00	
3 : Colburn	0.00	LS	0.00	6,793.2	0.0	0.00	6,793.22	
4 : DeHart	0.00	LS	0.00	680.0	0.0	0.00	680.00	
5 : Kanske	0.00	LS	0.00	920.4	0.0	0.00	920.44	

Total Change Amount: 0.00

Notes:

Approved By:

3/24/2026

Construction Manager:

Date:

04/03/2026

Architect:

Date:

4/6/26

Owner:

Date:



WILJO INTERIORS, INC.

2100 N Indianwood Broken Arrow, OK
74012

7421 NW 83rd St., OKC, OK 73132

Phone: (918) 250-0679

Phone: (405) 792-7979

Fax: (918) 250-0112

Fax: (405) 792-7980

www.wiljointeriors.com

ATTN: Shawn Vick
Willowbrook Construction Services

JOB: **Stillwater High School Phase 1
Guidance Check-in 1034 Ceiling**

DATE: 2/18/2026

PLAN DATE: N/A

PER ADDENDUM:

We propose to furnish and install the following scope of work as listed below, per the plans and specifications:

	AMOUNT
Layout of our work from established points given by others. Clean up of our debris into a dumpster provided by others. Equipment/lifts/scaffolding to perform our work. Suspended acoustical ceilings. Added acoustical ceiling using Armstrong #1811 (ACT-1) in Guidance Check-in 1034.	
Materials.....\$623 Labor & burdens.....\$171 Overhead & profit.....\$79 Bond.....\$13	\$886
ALTERNATES:	
EXCLUSIONS: Wood; Blocking wood or metal; Exposed caulking; Dumpsters; Sealing of MEP penetrations; Engineering; Demolition;	

Respectfully Submitted,

Ken Fry
Project Manager

Request for Change Order

Project: 88709 Stillwater Schools	Request for Change Order Number: 0021
	Title: Change in room 1034
	Request for Change Order Date: Feb 3, 2026
To: CMS Willowbrook	Architect's Project No:
	Contract Date:

We propose to make the following changes in this contract :

PCO:0021

Name: Change in room 1034	Source:	Type:
----------------------------------	----------------	--------------

Description: pricing to extend the supply ductwork in room 1034 a few feet and install a 2'x2' lay in grille

Scope of work:

Amount: 680.00

Cost Items:

Number	Name	Description	Amount
01	Labor		285.00
02	Material		395.00

Markups for above items are listed below:

Number	Name	Description	Amount
---------------	-------------	--------------------	---------------

Cost Items inclusive of markups:

Number	Name	Description	Amount
01	Labor		285.00
02	Material		395.00

The total Cost to perform the work as described above is a CHANGE of 680.00.

Please indicate your acceptance and approval of this additional work in the space provided below

CONTRACTOR

February 19, 2026

Willowbrook Construction

Attn: Shawn Vick

Stillwater High School
Stillwater, OK



KANSKE FIRE SYSTEMS, LLC
394 Murray Dr.
Choctaw, OK 73020
License #440847
www.kanskefire.com

Change Order #5

Based on the information provided, we are pleased to provide you with this quote to modify the fire sprinkler system.

Scope of work includes:

- To modify the sprinkler head locations to accommodate the new ceiling in the Guidance Check-in area.
- To replace the existing upright sprinklers with (2) new EC pendent sprinkler heads. (center of tile with flex drops)
- To replace the heads after the new ceiling grid is installed.
- Work to be performed in 8-hour shifts, during regular 7am to 4pm working hours.

Design	0 Hrs @ \$95.00 per hour	\$ 0.00
Labor	4 (2)-man Crew Hrs @\$135.00 per hour	\$ 540.00
Materials		\$ 260.38
Taxes	@ 0.00%	\$ 0.00
Subtotal		= \$ 800.38
Overhead	@ 10%	\$ 80.04
		= \$ 880.42
Profit	@ 5%	\$ 40.02
		= \$ 920.44

Change Order #5 Price:

Nine Hundred Twenty Dollars \$920.00

Current Contract Amount -	\$521,315.00	
Change Order #1 Amount -	\$ 2,400.00 deduct	(Approved – Remove Alt #1 Classrooms from project)
Change Order #2 Amount -	\$ 31,212.00 add	(Open – PR #5 & #6)
Change Order #3 Amount -	\$218,637.00 add	(Open – Phase 2 Addition)
Change Order #4 Amount -	\$ 185.00 add	(Open – Nurse Waiting)
Change Order #5 Amount -	\$ 920.00 add	(Open – Guidance Check-in)
New Contract Total -	\$788,369.00	

This quote is valid for (30) days. Thank you for giving us the opportunity to provide you with this quote. Please let us know if we can help with any other budgets or quotes.

Jim Kanske (Cell: 405-318-8212)

Approved By: _____ Date: _____



Owner Contingency Modification

0309b. - Stillwater New High School

Title: OMOD 108 - PR 058 Gym Striping

Owner Contingency Modification : # 108

Date: 03/18/2026 Date Required:

Description of Work: The following scope of work is included in this PCO:

1. Provide additional floor striping and sleeves for the addition of a main volleyball court as outlined in PR 058.

The below items will increase or decrease the contract scheduled value by the amounts listed below. Time in days indicates additional time required to project completion due to the changes referenced.

Item	Units	UM	Unit Price	Item Total	Bonds & Ins	Fee	Total	Time (In days)
1 : OMOD 108 - PR 058 Gym Striping	0.00	LS	0.00	- 2,390.0	0.0	0.00	- 2,390.04	
2 : Vector Concepts	0.00	LS	0.00	890.0	0.0	0.00	890.00	
3 : SOPA	0.00	LS	0.00	1,500.0	0.0	0.00	1,500.04	

Total Change Amount: 0.00

Notes:

Approved By:

3/24/2026

Construction Manager:

Date:

04/03/2026

Architect:

Date:

4/6/26

Owner:

Date:



VECTOR CONCEPTS
 9010 N. Royal Lane, Suite 110
 Irving Texas 75063
 972-399-1303 office 972-790-7535 fax
 www.vectorconcepts.com

Available on **BuyBoard** **Change Order Request**
 Cooperative Purchasing of Project 14537

Contract Numbers
 737-24 (Sports) & 736-24 (Commercial)



Proposal #	50779
Customer PO	0309b.023
Contract #	0309b.023
Date	3/4/2026
Sales Person1	Jeff Woodard
Project Manager	Jon Noel

Acct # 2953
 For: 405 224-1554 Fax

WILLOWBROOK, INC
 3108 S 9TH ST
 CHICKASHA, OK 73018

Job Site:
STILLWATER NEW HIGH SCHOOL
PRACTICE GYM - C/O ADD MAIN VB COURT
/ CARY COX, 405-880-4890
410 W FRANKLIN LN
STILLWATER, OK 74075
Contact: SHAWN VICK, PROJECT
MANAGER 405 224-1554

Quantity	Unit	General Information / Description
1	EA	ENDURA PAINTS GAMELINE PAINTS WITH QUICK DRY - WHITE - STANDARD COLOR - 51706 ADD MAIN VOLLEYBALL COURT GAMELINES
1	EA	ENDURA PAINTS EP-FD PRIMER (500' 2" LINES) OR (100 SQ FT) - ENDURA EP-FD NEUTRAL KIT A&B
1	EA	INSTALLATION LABOR

<i>Total</i>	
Grand Total	\$890.00
Deposit	Date _____ Ck # _____

PROPOSAL SUBJECT TO CONTRACTUAL AGREEMENT

1926.1153 RESPIRABLE CRYSTALLINE SILICA OSHA COMPLIANCE FOR TABLE 1 ONLY

Tariffs and Fuel Surcharge Clause:

In the event that any tariffs, duties, or fuel surcharges are imposed on materials, products, or transportation services required to fulfill this order after the effective date of the agreement, Vector Concepts, Inc. reserves the right to pass such additional costs on to the Customer. Upon written request, Vector Concepts, Inc. will provide documentation of such charges. Any resulting adjustments will be handled by Change Order.

TERMS: PAYMENT IN ADVANCE unless credit is approved and other terms are agreed. Vector Concepts will furnish, deliver, and install the above material in accordance with manufacturers guidelines for the listed price. Client is responsible for the condition of the job site which is concrete fit for purpose, to be broom swept, clear of trash & debris, other trades work completed, and ready for floor coverings. Unless specifically included, this proposal excludes: all demolition, repair of take-up of existing flooring; vacuuming, damp mopping, buffing, waxing or floor protection; floor floating, leveling or repair; sealing of floor, cleaning of removal of oil, grease, solvents, paints, plaster, or other foreign substances: asbestos control/abatement: attic stock of material: furniture movement; and addenda beyond the base bid per industry standard site conditions. This proposal includes only work during regular hours and for a single phase job. Client must submit to Vector Concepts a written report on moisture and surface alkalinity of the slab to determine its suitability as a substrate for the material to be installed. Any floor preparation or activity not included in this proposal will be billed on a time plus material basis. Client is subject to payment for stored materials whether on job site or in Vector Concepts warehouse. Vector Concepts will not accept charge backs for damage or cleaning without the option to inspect claim(s) and to repair or to make arrangements for repairs of damages. Vector Concepts is not responsible for any claims that might result from product delivery date changes beyond their control. All product manufacture warranties are directly from manufacture. This proposal is valid for THIRTY (30) days.

Continuation For: WILLOWBROOK, INC, Quote # 50779

Quantity	Unit	General Information / Description
----------	------	-----------------------------------

Buyer _____ Date _____ Seller _____ Date _____



SOPA Inc
 241 Newman Drive
 North Little Rock, AR 72117

Change Order

Stillwater PS New HS - 25400253
Stillwater High School
410 West Franklin Lane
Stillwater, OK 74075

Change Order No. 3

Date: 03/16/2026
Sent By: Timothy Pawlicki
 tim@sopainc.com
 SOPA Inc

Respond By:
Sent To:

Change Reason:

Scope:

Title: Revised COR for One Set of Volleyball Sleeves with Synthetic Floor Installation

Description: The scope of this CO is to provide and install one additional set of volleyball sleeves and cover plates - including sleeve installation through synthetic flooring. SOPA is not responsible for any discoloration on the floor that results from installation, though we will do our best to keep the area clean and clear during and after install.

Schedule Impact:

Scope of Work

Item	Quantity	Unit Of Measure	Unit Price	Price Subtotal
Material - 2 total sleeves and coverplates	1	Lump Sum	\$301.24	\$301.24
Sleeve installation for 2 sleeves (1 volleyball system) through synthetic flooring. Includes core drilling, sleeve installation, and cover plate install	1	Lump Sum	\$1,176.70	\$1,176.70
Bond	1	Lump Sum	\$22.10	\$22.10
Price Subtotal:				\$1,500.04
Overhead:				
Total Price:				\$1,500.04

Review and Response

Approved Rejected Requested Revisions Other

Timothy Pawlicki
SOPA Inc



Owner Contingency Modification

0309b. - Stillwater New High School

Title: OMOD 109 - RFI 269 Servery 1176A Ceiling Height

Owner Contingency Modification : # 109

Date: 03/18/2026 **Date Required:**

Description of Work: The following scope of work is included in this PCO:

1. Provide material and labor to lower the ceiling in Servery 1176A for the lighting to be installed with out conflicting with overhead MEP as outlined in RFI 269.

The below items will increase or decrease the contract scheduled value by the amounts listed below. Time in days indicates additional time required to project completion due to the changes referenced.

Item	Units	UM	Unit Price	Item Total	Bonds & Ins	Fee	Total	Time (In days)
1 : OMOD 109 - RFI 269 Servery 1176A Ceiling Height	0.00	LS	0.00	- 330.0	0.0	0.00	- 330.00	
2 : Wiljo	0.00	LS	0.00	330.0	0.0	0.00	330.00	

Total Change Amount: 0.00

Notes:

Approved By:

Shawn Viall

3/24/2026

Construction Manager:

WBP

Date:

04/03/2026

Architect:

BT

Date:

4/6/26

Owner:

Date:



Owner Contingency Modification

0309b. - Stillwater New High School

Title: OMOD 110 - PR 061 - Paving Marking

Owner Contingency Modification : # 110

Date: 03/31/2026 Date Required:

Description of Work: The following scope of work is included in this PCO:

1. Provide additional paving marking and stenciling as outlined in PR 061.

The below items will increase or decrease the contract scheduled value by the amounts listed below. Time in days indicates additional time required to project completion due to the changes referenced.

Item	Units	UM	Unit Price	Item Total	Bonds & Ins	Fee	Total	Time (In days)
1 : OMOD 110 - PR 061 - Paving Marking	0.00	LS	0.00	- 4,200.0	0.0	0.00	- 4,200.00	
2 : Turning Point	0.00	LS	0.00	4,200.0	0.0	0.00	4,200.00	

Total Change Amount: 0.00

Notes:

Approved By:

Shawn Vail

4/02/2026

Construction Manager:

Date:

WBJ

04/03/2026

Architect:

Date:

John

4/6/26

Owner:

Date:



T.J. Abla
tabla@tpipaving.com
Cell: 405-313-9637
Office: 405-579-7663
Fax: 405-579-1693
Federal ID: 71-0913108
PO Box 1805 | Blanchard OK 73010

March 23, 2026

RE: Stillwater High School – 410 West Franklin Lane, Stillwater, Oklahoma

RFP – Additional Pavement Marking

DESCRIPTION:

- Add 12" "RESERVED FOR PATHFINDERS" Stencil to designated space (1)
- Add 12" "SMAC STUDENT PARKING" Stencil to designated spaces (13)
- Add 12" "SMAC STAFF PARKING" Stencil to designated spaces (20)
- Add 18" two-digit numbers to designated spaces (33)
- (Labor, Material & Equipment included to perform above scope of work, U.N.O)

TOTAL:

\$4,200.00

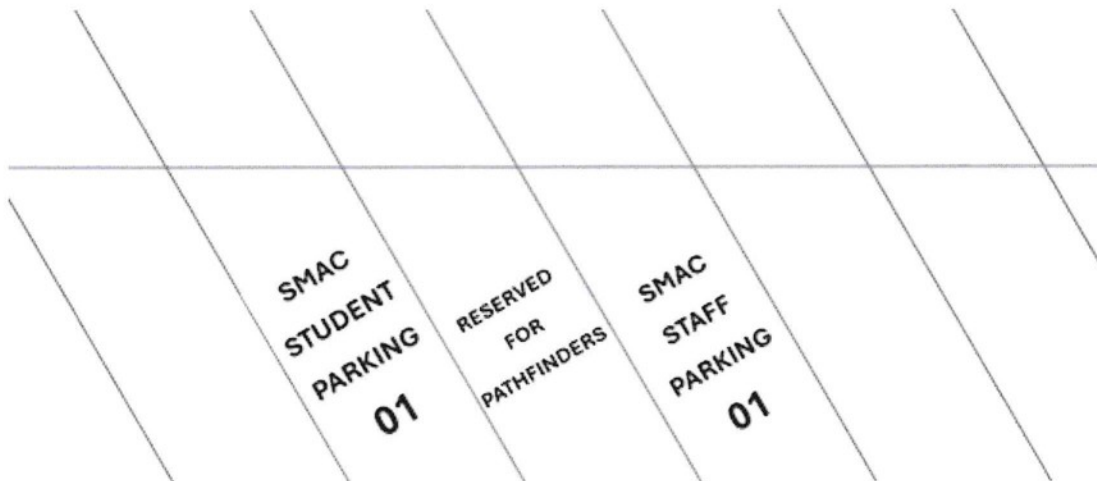

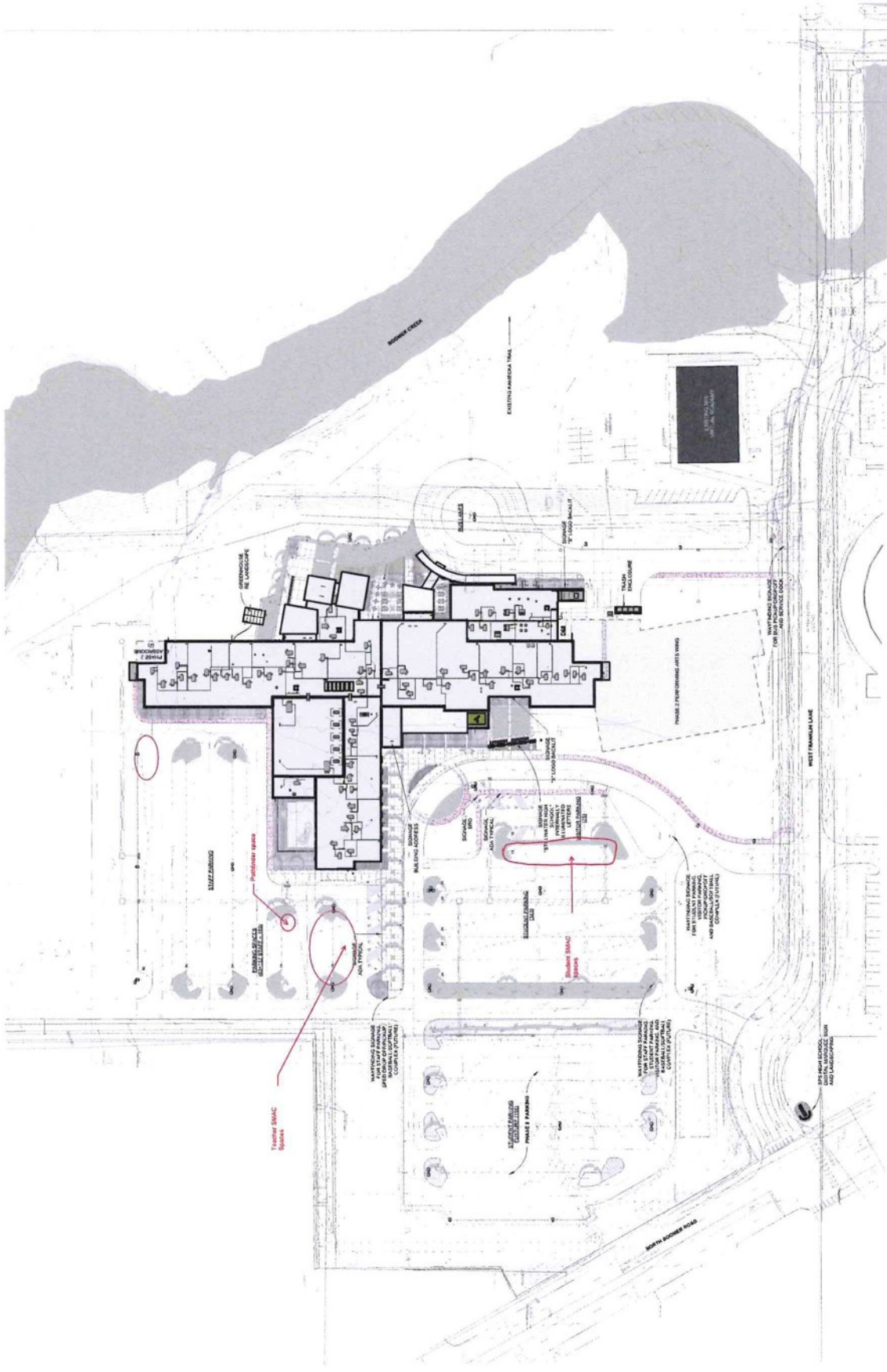



Owner Contingency Modification

0309b. - Stillwater New High School

Title: OMOD 111 - RFI 275 Pole Lighting Electrical Requirements

Owner Contingency Modification : # 111

Date: 03/31/2026 **Date Required:**

Description of Work: The following scope of work is included in this PCO:

1. Revise the electrical circuitry to accommodate the exterior pole lighting requirements as outlined in RFI 275.

The below items will increase or decrease the contract scheduled value by the amounts listed below. Time in days indicates additional time required to project completion due to the changes referenced.

Item	Units	UM	Unit Price	Item Total	Bonds & Ins	Fee	Total	Time (In days)
1 : OMOD 111 - RFI 275 Pole Lighting Electrical Requirements	0.00	LS	0.00	- 3,076.1	0.0	0.00	- 3,076.11	
2 : Colburn	0.00	LS	0.00	3,076.1	0.0	0.00	3,076.11	

Total Change Amount: 0.00

Notes:

Approved By:

4/02/2026

Construction Manager:

Date:

04/03/2026

Architect:

Date:

4/6/26

Owner:

Date:



BROKEN ARROW ELECTRIC SUPPLY INC
 2350 W. VANCOUVER ST
 BROKEN ARROW, OK 74012-1172
 Phone 9182583581
 Fax 9182513799



Quotation

EXPIRATION DATE	QUOTE NUMBER
03/20/2026	S3472769
BROKEN ARROW ELECTRIC SUPPLY INC 2350 W. VANCOUVER ST BROKEN ARROW, OK 74012-1172 Phone 9182583581 Fax 9182513799	PAGE NO.
	1 of 1

QUOTE TO:

SHIP TO:

COLBURN ELECTRIC
 829 W ELGIN ST
 BROKEN ARROW, OK 74012-2426

COLBURN/STILLWATER HIGH SCHOOL GEAR
 1701 BOOMER ROAD
 STILLWATER, OK 74074

CUSTOMER NUMBER	CUSTOMER PO NUMBER	JOB NAME / RELEASE NUMBER	SALESPERSON	
36992	STILLWAHER HIGH SCHOOL		Duane Rector	
WRITER	SHIP VIA	TERMS	SHIP DATE	FREIGHT ALLOWED
Kolby Coday		Net Due On Invoice	03/19/2026	No
ORDER QTY	DESCRIPTION		UNIT PRICE	EXT PRICE
	SHIPPING INSTRUCTIONS !!!!!!CUSTOMER MUST ALWAYS SIGN FOR MATERIAL!!!!			
8 10 ea	CHD PDG21F0020TFFL 1P 20A CB 1P 20A CB EATON POWER DEFENSE MOLDED CASE CIRCUIT BREAKER, GLOBALLY RATED, FRAME 2, SINGLE *** Special Order Item *** Pn: 484870		219.180/ea	2191.80 1753.44

Prices for bidding purposes only, please call for current pricing.
 See Terms and Conditions @ baes.com. Special order merchandise and
 cut wire are non-returnable. All sales
 are subject to Broken Arrow Electric Supply Inc terms and conditions
 found at baes.com, unless governed by other terms signed by an
 officer of BAES. All other terms are rejected.

Subtotal	2191.80
S&H Charges	0.00
Estimated Tax	0.00
Amount Due	2191.80 1753.44



RFI #RFI-275: Pole Lighting Electrical Requirements

Revision	0	Status	Open
To	Annie Hecksher (505 Architects) <i>(Response Required)</i> Jeff Thomas (505 Architects) <i>(Response Required)</i>	From	Shawn Vick (Willowbrook)
Date Initiated	Mar 2, 2026	Due Date	Mar 13, 2026
Location		Project Stage	Course of Construction
Cost Impact	TBD	Schedule Impact	
Spec Section		Cost Code	
Drawing Number	E500	Reference	
Linked Drawings			
Received From	Ben Burris (Colburn Electric)		
Copies To	Bryce Cooper (Willowbrook), Cary Cox (Willowbrook), Shawn Vick (Willowbrook), Trevor Yarborough (Willowbrook)		

Activity

Question **Question from Shawn Vick Willowbrook on Monday, Mar 2, 2026 at 09:38 AM CST**
Per E500, we are to provide 480V/20A to the exterior pole lights. The approved pole lights came in a 120/277V operation only. Please advise.

Awaiting an Official Response

**In response to RFI-275, we have the following comments:
It is acceptable to connect the exterior pole lights to 277VAC instead of 480VAC.
Response by Ryan Shoemake, Phillips+Gomez, Inc. Date: 03/05/2026**



Owner Contingency Modification

0309b. - Stillwater New High School

Title: OMOD 112 - RFI 280 - Removable Bollards

Owner Contingency Modification : # 112

Date: 03/31/2026 **Date Required:**

Description of Work: The following scope of work is included in this PCO:

1. Provide concrete apron to better secure the removable bollards as outlined in RFI 280.

The below items will increase or decrease the contract scheduled value by the amounts listed below. Time in days indicates additional time required to project completion due to the changes referenced.

Item	Units	UM	Unit Price	Item Total	Bonds & Ins	Fee	Total	Time (In days)
1 : OMOD 112 - RFI 280 - Removable Bollards	0.00	LS	0.00	- 5,000.0	0.0	0.00	- 5,000.00	
2 : Turning Point	0.00	LS	0.00	5,000.0	0.0	0.00	5,000.00	

Total Change Amount: 0.00

Notes:

Approved By:

Shawn Vail

4/02/2026

Construction Manager:

Date:

WBJ

04/03/2026

Architect:

Date:

R

4/6/26

Owner:

Date:



T.J. Abla
tabla@tpipaving.com
Cell: 405-313-9637
Office: 405-579-7663
Fax: 405-579-1693
Federal ID: 71-0913108
PO Box 1805 | Blanchard OK 73010

March 27, 2026

RE: Stillwater High School – 410 West Franklin Lane, Stillwater, Oklahoma

RFP – Additional Paving

DESCRIPTION:

- 8" HD PC Paving REF w/ #3 @ 18" OCEW on 6" ODOT A Agg Base (200 SF)
- (Labor, Material & Equipment included to perform above scope of work, U.N.O)

TOTAL:

\$5,000.00

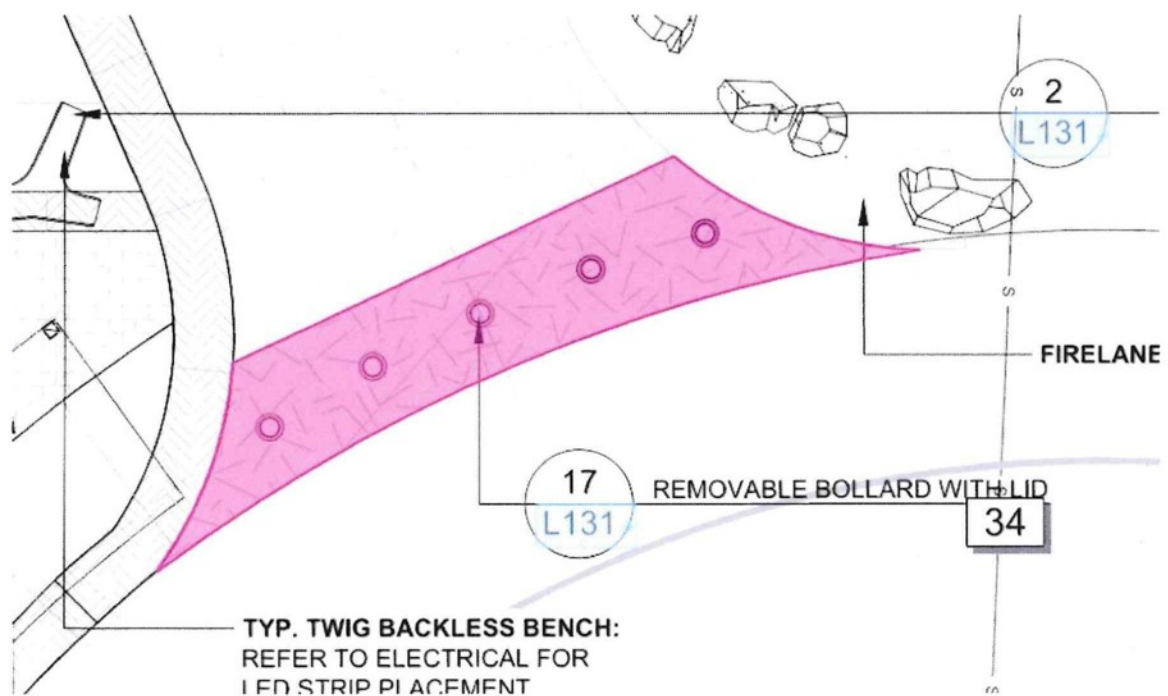



Owner Contingency Modification

0309b. - Stillwater New High School

Title: OMOD 113 - PR 059 Receptionist Speaker Opening

Owner Contingency Modification : # 113

Date: 04/01/2026 **Date Required:**

Description of Work: The following scope of work is included in this PCO:

1. Provide material and labor required to add a speaker hole at the Window Frame Type S-01 in Reception/Check-in 1002A as outlined in PR 059.

The below items will increase or decrease the contract scheduled value by the amounts listed below. Time in days indicates additional time required to project completion due to the changes referenced.

Item	Units	UM	Unit Price	Item Total	Bonds & Ins	Fee	Total	Time (In days)
1 : OMOD 113 - PR 059 Receptionist Speaker Opening	0.00	LS	0.00	- 295.0	0.0	0.00	- 295.00	
2 : Lee Glass	0.00	LS	0.00	295.0	0.0	0.00	295.00	

Total Change Amount: 0.00

Notes:

Approved By:

4/02/2026

Construction Manager:

Date:

04/03/2026

Architect:

Date:

4/6/26

Owner:

Date:



CHANGE ORDER DATE EXPIRATION DATE
#26821-23 3/30/2026 4/29/2026

CUSTOMER

Willowbrook Contruction Services
(405) 224-1554
hilary.peters@willowbrook.build

PO Box 807
Chickasha, ok 73023

JOB INFO

**CMS WILLOWBROOK-Stillwater
High School**
410 W Franklin Ln
Stillwater, OK 74075

LEE GLASS & WINDOW, LLC

1002 S Lewis St
Stillwater, OK 74074
(405) 372-6600
phil@leeglassco.com
<https://www.leeglassco.com/>

Add Change Order. Remove glass in window type S-01. Install new glass with a 3" hole, 4' 8" AFF, centered from left to right. Includes installation of an 834A, no draft speak thru grill.

ITEMS

SUBTOTAL

1/4" clear tempered glass with 3" diameter hole.	\$165.00
834A Satin Anodized No Draft Speak Through Grill	\$30.00
Labor to remove old glass, and install new glass and speaker grill.	\$100.00

Total: \$295.00



STILLWATER PUBLIC SCHOOLS
STILLWATER BOARD OF EDUCATION

PREPARED BY: Bo Gamble, Assistant Superintendent for Operations
APPROVED BY: Tyler Bridges, Superintendent
DATE: April 14, 2026

AGENDA ITEM:

Consider and Vote to Authorize Superintendent to Solicit Bids for the SPS Richmond Elementary and Skyline Elementary Security, Safety, and Finish Improvements Pursuant to the Competitive Bidding Act of 1974

BOARD ACTION REQUESTED:

Vote to Authorize Superintendent to Solicit Bids for the SPS Richmond Elementary and Skyline Elementary Security, Safety, and Finish Improvements Pursuant to the Competitive Bidding Act of 1974

BACKGROUND INFORMATION:

This project would provide secure entry vestibules and gymnasium floor surface improvements at Skyline Elementary and secure entry vestibules, gymnasium floor surface improvements, wall finish improvements, and the construction of a seclusion room based on SPS District standards at Richmond Elementary. Funds for these projects are available in existing bond dollars with an estimated cost of \$667,000.00.



STILLWATER PUBLIC SCHOOLS
STILLWATER BOARD OF EDUCATION

PREPARED BY: Bo Gamble, Assistant Superintendent of Operations
APPROVED BY: Tyler Bridges, Superintendent
DATE: April 14, 2026

AGENDA ITEM:

Consider and Vote to Approve Service Order No.31R1 with 505 Architects for professional services, including preparation of construction documents for the SPS Richmond Elementary and Skyline Elementary Security, Safety, and Finish Improvements Project

BOARD ACTION REQUESTED:

Vote to Approve Service Order No.31 with 505 Architects for professional services, including preparation of construction documents for the SPS Richmond Elementary and Skyline Elementary Security, Safety, and Finish Improvements Project

BACKGROUND INFORMATION:

The Architect shall provide architectural services for the portions of the Project relative to the scope of Work. The scope of services includes reviewing and analyzing Owner-provided existing design and/or as-built documents, reviewing for ADA and code compliance, and preparing Construction Documents suitable for bidding, permitting, and construction of the Scope of Work. Construction Administration includes one (1) site visit by the architect to each site. Construction Documents, Bidding, Permitting, and Construction Administration services are included.



AIA[®] Document B221[™] – 2018

Service Order for use with Master Agreement Between Owner and Architect

SERVICE ORDER number 31R1 made as of the fourteenth day of April in the year two-thousand and twenty-six
(In words, indicate day, month, and year.)

BETWEEN the Owner:
(Name, legal status, address, and other information)

Independent School District No. 16 of Payne County , Oklahoma
314 South Lewis Street
Stillwater, Oklahoma 74074

and the Architect:
(Name, legal status, address, and other information)

505 Architects LLC
1631 South Delaware Avenue
Tulsa, Oklahoma 74104

for the following **PROJECT**:
(Name, location, and detailed description)

SPS Richmond Elementary Security, Safety and Finish Improvements Construction Documents, Bidding and Construction Administration Phases for the interior renovation to provide a secure entry, wall finish improvements, gymnasium floor surface improvements, and a seclusion room based on SPS District standards within the existing SPS Richmond Elementary located at 201 West Richmond Road, Stillwater, Oklahoma.

SPS Skyline Elementary Security, Safety and Finish Improvements. Construction Documents, Bidding and Construction Administration Phases for the interior renovation to provide a secure entry, and gymnasium floor surface improvements based on SPS District standards within the existing SPS Skyline Elementary located at 1402 East Sunrise Avenue, Stillwater, Oklahoma

THE SERVICE AGREEMENT

This Service Order, together with the Master Agreement between Owner and Architect dated the thirteenth day of April in the year two-thousand and twenty-one
(In words, indicate day, month, and year.)

form a Service Agreement.

The Owner and Architect agree as follows.

ADDITIONS AND DELETIONS:
The author of this document may have revised the text of the original AIA standard form. An *Additions and Deletions Report* that notes revisions to the standard form text is available from the author and should be reviewed. A vertical line in the left margin of this document indicates where the author has added to or deleted from the original AIA text.

This document has important legal consequences. Consultation with an attorney is encouraged with respect to its completion or modification.

This document provides the Architect's scope of services for the Service Order only and is intended to be used with AIA Document B121[™]–2018, Standard Form of Master Agreement Between Owner and Architect

TABLE OF ARTICLES

- 1 INITIAL INFORMATION
- 2 SERVICES UNDER THIS SERVICE ORDER
- 3 DATE OF COMMENCEMENT AND SUBSTANTIAL COMPLETION
- 4 COMPENSATION
- 5 INSURANCE
- 6 PARTY REPRESENTATIVES
- 7 ATTACHMENTS AND EXHIBITS

ARTICLE 1 INITIAL INFORMATION

§ 1.1 Unless otherwise provided in an exhibit to this Service Order, this Service Order and the Service Agreement are based on the Initial Information set forth below:

(State below details of the Project's site and program, Owner's contractors and consultants, Architect's consultants, Owner's budget and schedule, anticipated procurement method, Owner's Sustainable Objective, and other information relevant to the Project.)

- 1.1.1 The Project consists of interior security, safety, and finish improvements as follows:
 - 1.1.2 SPS Richmond Elementary
 - 1.1.2.1 Interior renovation to provide a secure entry lobby within main entrance lobby.
 - 1.1.2.2 Interior wall painting at vestibules, lobby, corridors, classrooms, and media center. Excludes painting of gymnasium, cafeteria, mechanical rooms, storage and closet rooms spaces.
 - 1.1.2.3 Replacement of existing gymnasium floor surface with athletic flooring system based on the SPS District standards utilized at the Westwood gymnasium.
 - 1.1.2.4 Renovation of existing NE vestibule to maintain code required egress from the building and incorporation of a seclusion room based on the SPS District standards utilized at the Westwood Seclusion Room.
 - 1.1.3 SPS Skyline Elementary
 - 1.1.3.1 Interior renovation to provide a secure entry vestibule within main entrance lobby.
 - 1.1.3.2 Replacement of existing gymnasium floor surface with athletic flooring system based on the SPS District standards utilized at the Westwood gymnasium
- 1.1.2 Owners budget for the cost of the Work is unknown.
- 1.1.3 Architect's Consultants for Basic and Additional Services include:
 - None
- 1.1.4 The Owner shall be responsible for obtaining hazardous material studies, geotechnical testing and surveys.

§ 1.2 The Owner and Architect may rely on the Initial Information. Both parties, however, recognize that such information may materially change and, in that event, the Owner and the Architect shall appropriately adjust the schedule, the Architect's services, and the Architect's compensation. The Owner shall adjust the Owner's budget for the Cost of the Work and the Owner's anticipated design and construction milestones, as necessary, to accommodate material changes in the Initial Information.

ARTICLE 2 SERVICES UNDER THIS SERVICE ORDER

§ 2.1 The Architect's Services under this Service Order are described below or in an exhibit to this Service Order, such as a Scope of Architect's Services document.

§ 2.1.1 Basic Services

(Describe below the Basic Services the Architect shall provide pursuant to this Service Order or state whether the services are described in documentation attached to this Service Order.)

The Architect shall provide architectural services for the portions of the Project relative to the scope of Work. No civil engineering, landscape architecture, structural engineering, mechanical engineering, electrical engineering, plumbing engineering, fire protection design, or food service equipment design services are anticipated based on the current scope of Work but can be provided as an Additional Service.

Mechanical, electrical, plumbing, and low-voltage system design will be delegated design utilizing same products as the new High School.

Scope of services include to review and analyze Owner provided existing design and/or as-built documents, review for ADA and code compliance and prepare Construction Documents suitable for bidding, permitting and construction of the Scope of Work.

Construction Administration includes one (1) site visit by Architect to each site.

Construction Documents, Bidding, Permitting and Construction Administration services are included.

§ 2.1.2 Additional Services

(Describe below the Additional Services the Architect shall provide pursuant to this Service Order or state whether the services are described in documentation attached to this Service Order.)

Phase 701 Vestibule Mechanical Modification

Mechanical engineering services to engineer and document additional modifications to the existing mechanical system serving the new secure entry vestibules beyond was is shown in the basic Scope of Work.

ARTICLE 3 DATE OF COMMENCEMENT AND SUBSTANTIAL COMPLETION

§ 3.1 Unless otherwise provided in an exhibit to this Service Order, the Owner's anticipated dates for commencement of construction and Substantial Completion of the Work are set forth below:

- .1 Commencement of construction date:

May 2026

- .2 Substantial Completion date:

August 2026

ARTICLE 4 COMPENSATION

§ 4.1 For Basic Services described under Section 2.1.1, the Owner shall compensate the Architect as follows:

Compensation for Basic Services shall be a fixed Fee plus reimbursable expenses as follows:

Phase 400 Construction Documents Phase	Fixed	\$12,000.00 plus reimbursable expenses per Section 4.3
Phase 500 Bidding and Permitting Services	Fixed	\$1,000.00 plus reimbursable expenses per Section 4.3
Phase 600 Construction Phase	Fixed	\$3,000.00 plus reimbursable expenses per Section 4.3
Phase 701 Vestibule Mechanical Modifications	Hourly	\$3,000.00 plus reimbursable expenses per Section 4.3

§ 4.2 For Additional Services described under Section 2.1.2 or in the Master Agreement, the Architect shall be compensated in accordance with the Master Agreement unless otherwise set forth below:

(Insert amount of, or basis for, compensation if other than as set forth in the Master Agreement. Where the basis of compensation is set forth in an exhibit to this Service Order, such as a Scope of Architect's Services document,

list the exhibit below.)

The Architect shall endeavor to provide a fixed fee for Additional Services when a scope of services can be clearly defined. In all instances, the Architect shall notify the Owner in writing of the need for Additional Services. If a scope of Work cannot be clearly defined, upon written approval from the Owner the Architect shall perform the Work on an hourly basis until such a time as the scope of Work can be defined and a fixed fee can be established.

Hourly billing rates at the time of this Agreement are set forth as follows:

505 Architects LLC			
Principal	\$200.00	Architect	\$185.00
Project Manager	\$195.00	Architectural Intern	\$140.00
Interior Designer	\$175.00	Administrative	\$90.00
Green Acorn, LLC (Mechanical Engineering)			
Officer / Principal	\$225.00	Engineer Coordinator II	\$155.00
Senior Design Engineer	\$185.00	Engineer Coordinator I	\$145.00
Engineer	\$165.00	Mechanical/Electrical Designer	\$120.00

§ 4.3 For Reimbursable Expenses described in the Master Agreement, the Architect shall be compensated in accordance with the Master Agreement unless otherwise set forth below:

(Insert amount of, or basis for, compensation if other than as set forth in the Master Agreement. Where the basis of compensation is set forth in an exhibit to this Service Order, such as a Scope of Architect's Services document, list the exhibit below.)

Reimbursable Expenses are estimated to not exceed \$2,500.00.

The Purchase Order should be written for an amount to include Basic Services, Additional Services, and an allowance for Reimbursable Expenses.

§ 4.4 When compensation identified in Section 4.1 is on a percentage basis, progress payments for each phase of Basic Services shall be calculated by multiplying the percentages identified in this Article by the Owner's most recent budget for the Cost of the Work. Compensation paid in previous progress payments shall not be adjusted based on subsequent updates to the Owner's budget for the Cost of the Work.

ARTICLE 5 INSURANCE

§ 5.1 Insurance shall be in accordance with section 3.3 of the Master Agreement, except as indicated below:

(Insert any insurance requirements that differ from those stated in the Master Agreement, such as coverage types, coverage limits, and durations for professional liability or other coverages.)

ARTICLE 6 PARTY REPRESENTATIVES

§ 6.1 The Owner identifies the following representative in accordance with Section 1.4.1 of the Master Agreement:

(List name, address, and other information.)

Assistant Superintendent of Operations
Bo Gamble
Stillwater Public Schools
314 South Lewis Street
Stillwater, Oklahoma 74074

§ 6.2 The Architect identifies the following representative in accordance with Section 1.5.1 of the Master Agreement:

(List name, address, and other information.)

Brian Thomas, AIA, RID, LEED AP

Principal | Owner
505 Architects LLC
1631 South Delaware Avenue
Tulsa, Oklahoma 74104

ARTICLE 7 ATTACHMENTS AND EXHIBITS

§ 7.1 The following attachments and exhibits, if any, are incorporated herein by reference:

- .1 AIA Document, B121™-2018, Standard Form of Master Agreement Between Owner and Architect for Services provided under multiple Service Orders;

This Service Order entered into as of the day and year first written above.

OWNER *(Signature)*

BY: Roberta Douglas; School Board
President

(Printed name and title)



ARCHITECT *(Signature)*

BY: Brian Thomas, AIA, RID, LEEP AP;
Principal | Owner

(Printed name, title, and license number if required)



STILLWATER PUBLIC SCHOOLS
STILLWATER BOARD OF EDUCATION

PREPARED BY: Bo Gamble, Assistant Superintendent of Operations
APPROVED BY: Tyler Bridges, Superintendent
DATE: April 14, 2026

AGENDA ITEM:

Consider and Vote to Approve Service Order No.32 with 505 Architects for professional services related to the Bond 2023 High School Athletics Phase I Demolition of the High School Football Building

BOARD ACTION REQUESTED:

Vote to Approve Service Order No.32 with 505 Architects for professional services related to the Bond 2023 High School Athletics Phase I Demolition of the High School Football Building

BACKGROUND INFORMATION:

Architect services under Service Order 32 shall include the redesign and preparation of documentation to revise civil and landscape drawings for the removal of the existing High School Football Building and the shifting of the artificial turf practice field to the west, approximately 10 feet. This includes site grading, utilities, storm sewer water lines, hardscaping, landscaping, and electrical site lighting.



AIA[®] Document B221[™] – 2018

Service Order for use with Master Agreement Between Owner and Architect

SERVICE ORDER number 32 made as of the fourteenth day of April in the year two-thousand and twenty-five
(In words, indicate day, month, and year.)

BETWEEN the Owner:
(Name, legal status, address, and other information)

Independent School District No. 16 of Payne County , Oklahoma
314 South Lewis Street
Stillwater, Oklahoma 74074

and the Architect:
(Name, legal status, address, and other information)

505 Architects LLC
1631 South Delaware Avenue
Tulsa, Oklahoma 74104

for the following **PROJECT**:
(Name, location, and detailed description)

SPS Bond 2023 High School Athletics Phase 1
Phase 709 Demolition of HS Football Building

THE SERVICE AGREEMENT

This Service Order, together with the Master Agreement between Owner and Architect dated the thirteenth day of April in the year two-thousand and twenty-one
(In words, indicate day, month, and year.)

form a Service Agreement.

The Owner and Architect agree as follows.

ADDITIONS AND DELETIONS:

The author of this document may have revised the text of the original AIA standard form. An *Additions and Deletions Report* that notes revisions to the standard form text is available from the author and should be reviewed. A vertical line in the left margin of this document indicates where the author has added to or deleted from the original AIA text.

This document has important legal consequences. Consultation with an attorney is encouraged with respect to its completion or modification.

This document provides the Architect's scope of services for the Service Order only and is intended to be used with AIA Document B121[™]–2018, Standard Form of Master Agreement Between Owner and Architect

TABLE OF ARTICLES

- 1 INITIAL INFORMATION
- 2 SERVICES UNDER THIS SERVICE ORDER
- 3 DATE OF COMMENCEMENT AND SUBSTANTIAL COMPLETION
- 4 COMPENSATION
- 5 INSURANCE
- 6 PARTY REPRESENTATIVES
- 7 ATTACHMENTS AND EXHIBITS

ARTICLE 1 INITIAL INFORMATION

§ 1.1 Unless otherwise provided in an exhibit to this Service Order, this Service Order and the Service Agreement are based on the Initial Information set forth below:

(State below details of the Project's site and program, Owner's contractors and consultants, Architect's consultants, Owner's budget and schedule, anticipated procurement method, Owner's Sustainable Objective, and other information relevant to the Project.)

Phase 709 Demolition of HS Football Building

The Project consists of redesign and prepare documentation to revise civil and landscape drawings for the removal of the existing High School Football Building and the shifting of artificial turf practice field to west approximately 10 feet. This includes site grading, utilities, storm sewer water lines, hardscaping, landscaping, and electrical site lighting.

§ 1.2 The Owner and Architect may rely on the Initial Information. Both parties, however, recognize that such information may materially change and, in that event, the Owner and the Architect shall appropriately adjust the schedule, the Architect's services, and the Architect's compensation. The Owner shall adjust the Owner's budget for the Cost of the Work and the Owner's anticipated design and construction milestones, as necessary, to accommodate material changes in the Initial Information.

ARTICLE 2 SERVICES UNDER THIS SERVICE ORDER

§ 2.1 The Architect's Services under this Service Order are described below or in an exhibit to this Service Order, such as a Scope of Architect's Services document.

§ 2.1.1 Basic Services

(Describe below the Basic Services the Architect shall provide pursuant to this Service Order or state whether the services are described in documentation attached to this Service Order.)

The Architect shall redesign and prepare documentation to revise civil and landscape drawings for the removal of the existing High School Football Building and the shifting of artificial turf practice field to west approximately 10 feet. This includes site grading, utilities, storm sewer water lines, hardscaping, landscaping, and electrical site lighting,

§ 2.1.2 Additional Services

(Describe below the Additional Services the Architect shall provide pursuant to this Service Order or state whether the services are described in documentation attached to this Service Order.)

None

ARTICLE 3 DATE OF COMMENCEMENT AND SUBSTANTIAL COMPLETION

§ 3.1 Unless otherwise provided in an exhibit to this Service Order, the Owner's anticipated dates for commencement of construction and Substantial Completion of the Work are set forth below:

.1 Commencement of construction date:

June 2026

.2 Substantial Completion date:

June 2028

ARTICLE 4 COMPENSATION

§ 4.1 For Basic Services described under Section 2.1.1, the Owner shall compensate the Architect as follows:

Compensation shall for Basic Services fees will be billed monthly based on percentage of completion plus reimbursable expenses as follows:

Phase 709 Demolition of HS Football Building Fixed \$20,000.00 plus reimbursable expenses per Section 4.3

§ 4.2 For Additional Services described under Section 2.1.2 or in the Master Agreement, the Architect shall be compensated in accordance with the Master Agreement unless otherwise set forth below:

(Insert amount of, or basis for, compensation if other than as set forth in the Master Agreement. Where the basis of compensation is set forth in an exhibit to this Service Order, such as a Scope of Architect's Services document, list the exhibit below.)

§ 4.3 For Reimbursable Expenses described in the Master Agreement, the Architect shall be compensated in accordance with the Master Agreement unless otherwise set forth below:

(Insert amount of, or basis for, compensation if other than as set forth in the Master Agreement. Where the basis of compensation is set forth in an exhibit to this Service Order, such as a Scope of Architect's Services document, list the exhibit below.)

Reimbursable Expenses are estimated to not exceed \$0.00

The Purchase Order should be written for an amount to include Basic Services, Additional Services, and an allowance for Reimbursable Expenses.

§ 4.4 When compensation identified in Section 4.1 is on a percentage basis, progress payments for each phase of Basic Services shall be calculated by multiplying the percentages identified in this Article by the Owner's most recent budget for the Cost of the Work. Compensation paid in previous progress payments shall not be adjusted based on subsequent updates to the Owner's budget for the Cost of the Work.

ARTICLE 5 INSURANCE

§ 5.1 Insurance shall be in accordance with section 3.3 of the Master Agreement, except as indicated below:

(Insert any insurance requirements that differ from those stated in the Master Agreement, such as coverage types, coverage limits, and durations for professional liability or other coverages.)

ARTICLE 6 PARTY REPRESENTATIVES

§ 6.1 The Owner identifies the following representative in accordance with Section 1.4.1 of the Master Agreement:

(List name, address, and other information.)

Assistant Superintendent of Operations
Bo Gamble
Stillwater Public Schools
314 South Lewis Street
Stillwater, Oklahoma 74074

§ 6.2 The Architect identifies the following representative in accordance with Section 1.5.1 of the Master Agreement:

(List name, address, and other information.)

Brian Thomas, AIA, RID, LEED AP
Principal | Owner
505 Architects LLC
1631 South Delaware Avenue
Tulsa, Oklahoma 74104

ARTICLE 7 ATTACHMENTS AND EXHIBITS

§ 7.1 The following attachments and exhibits, if any, are incorporated herein by reference:

- .1 AIA Document, B121™-2018, Standard Form of Master Agreement Between Owner and Architect for Services provided under multiple Service Orders;

This Service Order entered into as of the day and year first written above.

OWNER *(Signature)*

BY: Roberta Douglas; School Board
President

(Printed name and title)



ARCHITECT *(Signature)*

BY: Brian Thomas, AIA, RID, LEEP AP,
Principal | Owner

(Printed name, title, and license number if required)



STILLWATER PUBLIC SCHOOLS
STILLWATER BOARD OF EDUCATION

PREPARED BY: Rob Lamecker, Director of Facilities/Maintenance
APPROVED BY: Tyler Bridges, Superintendent
DATE: April 14, 2026

AGENDA ITEM:

Consider and Vote to Declare Facilities, Child Nutrition, and Transportation Equipment as Surplus Property

BOARD ACTION REQUESTED:

Vote to Approve Facilities, Child Nutrition, and Transportation Equipment as Surplus Property

BACKGROUND INFORMATION:

Periodically, district-owned property is discovered to be no longer useful or no longer needed. When this point arrives, the property is presented to the Board of Education for consideration to declare and vote to approve presented items as surplus. Attached is a list from the Transportation, Facilities, and Child Nutrition Department of items to be considered as surplus.

Final disposition of surplus items will be in accordance with applicable state laws.

Quantity	Make	Model	Description	SPS Tag	Serial Number
1 Set	Descon	Color Art	Set of 9 framed photos	None	None
2	GE	Unknown	Chest freezers	None	Unknown
1	Frigidaire	GLFC2528FW4	Chest freezer	None	WB73929782
1	GE	FCM 25DTC WH	Chest freezer	None	SM170585
3	Randell	2011M	Glass door reach in refrigerator	None	S00000006105, S00000006098, S00000006094
1	Unknown	Unknown	Stainless work table with 2 drawers	None	None
1	Randell	Ran Cam	Cashier stand locking cash drawer. Slid tray slide with drop down brackets	None	W00000031029
1	Randell	Ran Cam	Cashier stand locking cash drawer. Solid tray slides with drop down brackets on 3 sides.	None	W00000031022
4	Randell	Ran ST3M	Buffet style worktop unit, enclosed base. Solid tray slide with drop down brackets	None	W00000031023
1	Randell	Ran HTD5SM	5 well cafeteria serving unit with dry storage; unknown functionality	None	W00000031026
2	Unknown	Unknown	Work table with butcher block top, lower shelf, and two drawers	None	Unknown
1	Unknown	Unknown	Work table with butcher block top, 3 drawers, and 2 large ingredient bins	None	Unknown
1	Unknown	Unknown	Work table with lower shelf, butcher block top, and two drawers	None	Unknown
1	Unknown	Unknown	Stainless work table with lower shelf, two drawers, and hanging pot rack	None	Unknown
1	Randell	Ran ST4M	Buffet Syle Worktop Unit, enclosed base. Solid tray slide with drop down brackets. Mirror of matching unit.	None	W00000031028
1	Randell	Ran ST4M	Buffet Syle Worktop Unit, enclosed base. Solid tray slide with drop down brackets. Mirror of matching unit.	None	W00000031027
1	Randell	Unknown	Cold serving unit with 2 upper glass shelves, solid tray slide with drop down brackets.	None	Unknown
2	Randell	RAN ST43M	Cafeteria Syle Worktop Unit Open Base. 8 holes for silverware or condiment inserts.	None	W00000031036, W00000031035
1	TRUE	TMC-49-S	Single-sided milk cooler	None	5351001
1	TRUE	TMC-34-S	Single-sided milk cooler	22877	7857122
3	Victory	RA-2D-S1	Ultra Spec Half Solid Door Reach-In Refrigerator	None	H1203500, H1203502, H1203503
1	Montague	Unknon	2 burner gas range	None	Unknown
1	Whirlpool	WTW4815EW1	Washer - White - 28 Inch 3.5 cu. ft. Top Load Washer with 9 Wash Cycles	None	C53821209
1	Hotpoint	NVL333EB1WW	Dryer - White - 5.7 Cu. Ft. Extra-Large Capacity Electric Dryer	None	AD738142W
1	Groen	AH/1-40	40 gallon gas kettle	None	Unknown
1	TRUE	T-49	T-49 Reach-in solid swing door refrigerator. Was freezing at the time it was removed.	None	1-4341003

1	TRUE	TMC-49	TMC-49 Milk cooler	None	Unknown
2	Vollrath	P-32	ServeWell Food Table Stainless steel body with an open base and undershelf.	None	M37023-1755-NN
2	Vollrath	P-32 Hot Wells	ServeWell Food Table Stainless steel body with an open base and undershelf. 4 Wells	None	Unknown
1	Cres Cor	121-PH-1818-DLS	Cres Cor Full Height Non-Insulated Mobile Heated Cabinet w/ (11) Pan Capacity	None	EBD-J11329-1
1	Unknown	Unknown	Yellow laminate serving line with 4 dry wells, and ambient space.	None	Unknown

TRANSPORTATION - Vehicles

Make/Model	VIN Number	Miles
2007 Chevrolet C2500	1GCHC24U27E126814	109,176 miles
2007 Chevrolet C1500	3GCEC14V57G163807	157,673 miles
2014 Ford E-150	1FTNE1EW5EDA03941	106,200 miles
2009 International CE Sped bus w/lift	4DRAPSKK49B696904	189,652 miles



STILLWATER PUBLIC SCHOOLS
STILLWATER BOARD OF EDUCATION

PREPARED BY: Bo Gamble, Assistant Superintendent of Operations
APPROVED BY: Tyler Bridges, Superintendent
DATE: April 14, 2026

AGENDA ITEM:

Consider and Vote to Approve Resolution for Schools and Libraries Universal Services (E-Rate) for 2026-2027. This Resolution Authorizes Filing of the Form 471 Applications for Funding Year 2026-2027 and the Payment of the Applicant's Share upon Approval of Funding and Receipt of Services.

BOARD ACTION REQUESTED:

Vote to Approve Resolution for Schools and Libraries Universal Services (E-Rate) for 2026-2027. This Resolution Authorizes Filing of the Form 471 Applications for Funding Year 2026-2027 and the Payment of the Applicant's Share upon Approval of Funding and Receipt of Services.

BACKGROUND INFORMATION:

E-Rate provides funding for discounts to eligible schools and libraries for Internet access and internal connections. This is a yearly agenda item. The SPS E-Rate discount for Internet Access and Broadband data (WAN) Category 1 Services is 80% and Category 2 Services is 80%.

For Category 1 (Internet Access and Broadband Services), SPS re-requested the school-to-school network (WAN) connections. There is one noticeable change for the district Internet connection. Bandwidth usage remains much lower than SETDA.org recommendations, the Internet connection bandwidth was decreased from 10Gbps to 8Gbps. Additionally, some Internet service providers offer a "split local loop" which provides multiple pathways to a district's single Internet connection. This service is in place and continue to provide an increase in the capability and resiliency of the district's Internet connection.

For Category 2 (Internal Connections or Equipment), SPS requested the recurring hosted firewall licensing. In the future, SPS plans to use Category 2 funding to upgrade to 6GHz wireless when equipment is available and the current wireless network reaches its end-of-support date.

Site	Bandwidth	Site	Bandwidth
District Internet	8Gbps	Middle School	3Gbps
Administration Building	3Gbps	Lincoln Academy	3Gbps
North Operations	3Gbps	Highland Park	3Gbps
Technology	3Gbps	Richmond	3Gbps
High School (district hub)	8Gbps	Sangre Ridge	3Gbps
Stillwater Pioneer Virtual Academy	3Gbps	Skyline	3Gbps
SPS Ag Facility	3Gbps	Westwood (SLL)	3Gbps
Junior High School	3Gbps	Will Rogers	3Gbps

RESOLUTION

Be it resolved that the governing board for Stillwater Indep Sch Dist 16

1. Authorizes the filing of FCC Form 471, Schools and Libraries Universal Service Program Services Ordered for the fiscal year 07/01/2026-06/30/2027.

2. Authorizes payment of the applicant's share subject to the following conditions:
 - (1) Approval of funding of the discounted portion by the Schools and Libraries Division (SLD) of the Universal Service Administrative Company (USAC) and
 - (2) Receipt of services during the fiscal year 07/01/2026-06/30/2027.

Signature: _____ Date: _____

Printed Name: _____ Title: _____



FRN Report

04/05/26

Report Filters:
 Entity Number: 140110
 Funding Year: 2026

BEN	Applicant Name					Applicant City	ST	Sites	471 No.	Filing Date	SPIN	Service Provider		471 Nickname
Year	FRN	Status	Wave	Type	486 SSD	Cont. Date	Contract Number	Award Amt.	Disc%	Request	Commitment	Disbursed	Contract Exp	FRN Nickname
140110	Stillwater Indep Sch Dist 16					Stillwater	OK	9	261021309	2026-03-27	143004698	United Systems, LLC		STIL 2026 C2
2026	2699028200	Pending	N/A	IC		03/03/2026	STIL United Systems	72,808.32	80%	58,246.66	0.00	0.00	2029-09-30	1-Network
140110	Stillwater Indep Sch Dist 16					Stillwater	OK	9	261021454	2026-03-27	143015254	OneNet (Oklahoma State Regents)		STIL 2026 C2 Firewall
2026	2699028461	Pending	N/A	IC		02/27/2025	STIL OneNet Firewall	31,690.00	80%	14,216.00	0.00	0.00	2027-06-30	1-Firewall
140110	Stillwater Indep Sch Dist 16					Stillwater	OK	9	261023854	2026-03-27	143050324	Vero Fiber Networks		STIL 2026 C1 WAN
2026	2699032348	Pending	N/A	IA		03/14/2024	STIL VERO WAN 2429	325,133.04	80%	260,106.43	0.00	0.00	2027-06-30	1- Wan 10 Gbps
140110	Stillwater Indep Sch Dist 16					Stillwater	OK	9	261023854	2026-03-27	143050324	Vero Fiber Networks		STIL 2026 C1 WAN
2026	2699032367	Pending	N/A	IA		03/03/2026	STIL VERO WAN Sports	74,799.36	80%	59,839.49	0.00	0.00	2027-06-30	2 - Wan 10 Gbps Sports
140110	Stillwater Indep Sch Dist 16					Stillwater	OK	9	261027017	2026-03-27	143015254	OneNet (Oklahoma State Regents)		STIL 2026 C1 INT
2026	2699037647	Pending	N/A	IA		03/03/2026	STIL OneNet INT 8 Gb	49,916.30	80%	39,933.04	0.00	0.00	2027-06-30	1 - Internet Access 8 Gbps
140110	Stillwater Indep Sch Dist 16					Stillwater	OK	9	261027017	2026-03-27	143015254	OneNet (Oklahoma State Regents)		STIL 2026 C1 INT
2026	2699039025	Pending	N/A	IA				54,300.00	80%	43,440.00	0.00	0.00	2027-06-30	2 - Internet Access 10 Gbps Mtm
Grand Total								608,647.02		475,781.62	0.00	0.00		



STILLWATER PUBLIC SCHOOLS

STILLWATER BOARD OF EDUCATION

PREPARED BY: Barry Fuxa, Acting Superintendent

APPROVED BY: Tyler Bridges, Superintendent

DATE: April 14, 2026

AGENDA ITEM(S):

Approval of the following Stillwater Public Schools Contracts:

FY 2025-2026 Contracts and Agreements:

1. Finals site Addendum

FY 2026-2027 Contracts and Agreements:

1. DocAccess
2. Finals site

BOARD ACTION REQUESTED:

Approval of the FY 26 and FY 27 contracts

BACKGROUND INFORMATION:

By April 24, 2026, state and local governments with populations of 50,000 or more must make their websites and mobile apps accessible, complying with WCAG 2.1 Level AA standards. This rule applies to ALL digital content, including websites, PDFs, and third-party tools. These software packages will make our website compliant with these standards, and more accessible to our community. AudioEye provides integrated tools that enhance accessibility. DocAccess will provide automatic accessibility transcription to all PDFs on the website, within the Canvas LMS, and through coming process changes to accessible PDFs sent via email.

This Finalsite Order (the 'Order') is entered into by and between Active Internet Technologies, dba Finalsite ('Finalsite') and Stillwater School District 16 ("Customer") and sets forth the terms of Customer's use of the products and services set forth below ("**Pricing Summary**"). This Order, together with the Master Terms and Conditions for Services (the "**Master Terms**") located at <https://www.finalsite.com/masterterms/useducationagencies> and incorporated herein by this reference, form the entire agreement between the parties in respect of the products and services set forth below. Each of the individuals executing this Order represent and warrant that he or she is authorized to execute this Order on behalf of Customer or Finalsite, as applicable. Unless otherwise specified herein, any capitalized terms used in this Order shall have the meaning defined in the Master Terms.

In consideration of the promises set forth herein, and other good and valuable consideration, the receipt of which are hereby acknowledged, the parties hereby agree as follows:

A. Products and Services Pricing Summary

** Indicates products added*

[X] Indicates products removed

CMS Platform

Add-Ons	
* Support Plus	

Accessibility

Accessibility	
* AudioEye Managed	* AudioEye Subscription Setup

The above products, to include but not limited to (modules, integration, design and consulting) will be billed upon contract signature.

Application Services Subscriptions Costs:

Total Cost/Year during the Initial Term of this Order, subject to adjustment for any renewal term as provided below.

Total Setup Cost (USD)
\$1,500

Schedule	Addendum Amount
Period 1 - May 01 2026	\$ 700
Period 2 - Jul 01 2026	\$ 4,200
Period 3 - Jul 01 2027	\$ 4,200

B. Additional Terms

1. **Initial Term:** This addendum will take effect on the date this document is signed by both parties and remain in effect for the term stated in the agreement.
2. Unless otherwise specified in the Special Provisions above, this Order Form shall be renewed automatically for successive periods of () years (each a "Renewal Term") after the expiration of the Initial Term and any subsequent Renewal Term, unless Customer provides Finalsite, or Finalsite provides Customer, with a written notice to the contrary ninety (90) days prior to the end of the Initial Term or Renewal Term, as applicable.
3. **Effective Date:** Upon execution of this Order.
4. Finalsite standard maintenance and support is included in the subscription fees for Application Services set forth in this Order.
5. All Upgrades and Updates to the Application Services are included in the subscription fees for Application Services set forth in this Order.
6. In addition to Customer's obligations to pay the fees described in the fee table above, Customer agrees to reimburse Finalsite for all travel and other out-of-pocket expenses reasonably incurred by Finalsite in rendering any services described in this Order.

C. Payment Terms

1. All fees for the initial year of this Order shall be due upon execution of this Order. Unless otherwise specified, all dollars (\$) are United States currency. All fees for subsequent years shall be due upon the annual anniversary of the effective date of this Order.
2. Customer shall be invoiced for amounts due in respect of the first year of the Initial Term upon execution of this Order Form.
3. **Sales Tax:** If applicable, a copy of your Sales Tax Direct Pay Certificate or your Sales Tax Exemption Certificate must be returned with this Order Form.

Any SOWs to which links are provided above in Section A, "Pricing Summary," are incorporated into this Order by reference, and any professional services described therein are included as part of your software package. By signing below, Finalsite and Customer each agree to the terms and conditions of this Order, the Master Terms, and any SOWs incorporated by reference. By signing below, Finalsite and Customer each agree to the terms and conditions of this Order and the Master Terms.

On Behalf Of: Stillwater School District 16
Signature
Name (printed)

Active Internet Technologies ('AIT')
Signature 
Name (printed) Jim Calabrese

Title (printed)
Date

Title (printed)	CEO
Date	4/13/2026

D. Customer Contact Information

Please fill out the following information, which will be used by our deployment & accounting teams.

Billing Contact
Title
Address 5021 N Perkins Road
City, State Zip Stillwater, OK 74075
Phone
Email

Project Contact
Title
Phone
Email

*Executive Sponsor (Superintendent, Head of School, CFO, etc.)
Title
Email

*The Executive Sponsor should be separate from the Project Contact and is typically the Superintendent, Head of School, Business Manager, CFO, etc.



Accessible Document Service Proposal

Transform Your PDFs into Fully Accessible, Searchable, and Translatable Documents

PREPARED FOR

Stillwater Area Public School District, OK

PREPARED BY

Michael Rivera

Account Executive

DocAccess by CivicPlus

michael.rivera@civicplus.com

(916) 900-6619

Executive Summary

Stillwater Area Public School District, OK faces a critical deadline for PDF accessibility compliance. After analyzing **165** links across its web properties, the DocAccess tool discovered at least **158** documents that can—and need to be—served in an accessible format. With this agreement, DocAccess will ensure **all publicly available documents** are served in an accessible format.

DocAccess offers an immediate, cost-effective solution at just **\$11,974/year** — that's **significantly** less than traditional remediation in the first year alone, with instant deployment and ongoing compliance.

The Accessibility Challenge

Under the Americans with Disabilities Act (ADA) and recent Department of Justice guidelines, all public-facing digital content must be accessible to people with disabilities. This includes:

- ✓ Meeting WCAG 2.1 AA standards for all PDF documents
- ✓ Providing equal access to information for all users
- ✓ Avoiding costly lawsuits and compliance penalties
- ✓ Serving your community's **15-20%** of residents with disabilities
- ✓ According to the American Community Survey (ACS) 2022 5-year estimates for the Stillwater Area Public School District service area and Washington County, roughly 8-10% of residents speak a language other than English at home, with Spanish, Somali, Vietnamese, and Hmong among the most common. This supports offering translated documents to ensure access for non-English-speaking families.

The DocAccess Solution

DocAccess transforms your existing PDFs into fully accessible documents without changing your files or website structure. Our cloud-based solution provides:

Instant Accessibility

Automatic conversion to screen-reader compatible HTML with proper semantic structure and WCAG 2.1 AA compliance.

250 Language Translation

Real-time translation powered by Google Translate, prioritizing languages spoken in your service area.

AI-Powered Search & Q&A

Users can search within documents and ask questions in plain language, getting instant answers in their preferred language.

Live Visual Interpretation

24/7 access to professional interpreters via Aira for users who need additional assistance - included at no extra cost.

Mobile Optimization

Responsive design ensures perfect viewing on all devices, from smartphones to desktop computers.

Smart Image Description

AI-generated comprehensive alt-text for all images, charts, maps, and diagrams following WCAG best practices.

Standards & Laws We Help You Meet

ADA Title II & III

Compliance with Americans with Disabilities Act requirements for public entities and places of public accommodation.

Section 508

Federal accessibility standard required for all federal agencies and contractors.

WCAG 2.1 AA

International Web Content Accessibility Guidelines—the gold standard for digital accessibility.

PDF/UA (ISO 14289)

We test your documents against the International standard for universally accessible PDF documents.

Every Plan Includes

- ✓ **Unlimited document views** – No per-view charges, ever
- ✓ **Automatic new document processing** – New PDFs are processed as they're published
- ✓ **250 language translation** – Real-time translation powered by Google Translate
- ✓ **AI-powered Q&A** – Users can ask questions about document content in plain language
- ✓ **Live visual interpretation** – 24/7 Aira access for users who need additional assistance
- ✓ **Compliance dashboard** – Monitor your accessibility status in real-time
- ✓ **No setup fees** – Simple installation, no hidden costs

How DocAccess Compares to Other Per-Student Costs

Annual cost per student comparison

Textbooks (avg)	\$100-200/student
Chromebook/Device	\$100-150/student
LMS Subscription	\$3-10/student

🌟 DocAccess (full ADA compliance)

~\$2.11/student

🏠 K-12 Specific Compliance



IDEA Compliance

Support students with disabilities under IDEA requirements



Office for Civil Rights

Meet OCR accessibility mandates for public schools



Parent Accessibility

Ensure parents with disabilities can access school documents

Technical Excellence & Compliance



DocAccess is built on industry-leading standards and partnerships:

- ✓ Testing PDFs for WCAG 2.1 AA and PDF/UA compliance verified by VeraPDF validation
- ✓ Section 508 and ADA Title II & III compliance
- ✓ ISO 14289 (PDF/UA) standard adherence
- ✓ Tested with all major screen readers (JAWS, NVDA, VoiceOver)
- ✓ Regular audits by accessibility experts
- ✓ Continuous improvement through user and community feedback

Simple Implementation Process

1

Quick Installation (15 minutes)

Add one line of code to your website - similar to Google Analytics. Works with any CMS or platform.

2

Automatic Processing (24 hours)

DocAccess scans and processes all your PDFs, creating accessible versions without touching your original files.

3

Go Live & Stay Compliant

Your PDFs are now served in an accessible, translatable, and mobile-friendly format. New documents are processed automatically. Full dashboard for monitoring.

Investment & Value

Recommended Plan: K12 Education - 5,687 Students

\$11,974/year

For Publicly Available PDFs and Course Materials On-Demand on stillwaterschools.org

What's Included:

✓ Unlimited documents on stillwaterschools.org

✓ Unlimited document views and downloads

✓ Automatic processing of new documents

✓ All accessibility features (translation, Q&A, live assistance)

✓ Compliance monitoring dashboard

✓ Regular accuracy reviews by experts

✓ No setup fees or hidden costs

Frequently Asked Questions

Do I need to remediate my existing PDFs?

No. DocAccess creates WCAG 2.1 AA compliant HTML formats that are the gold standard for ADA requirements. Your original PDFs remain unchanged as an alternative format for printing.

How quickly can we be compliant?

Most organizations are fully operational within 24-48 hours of installing the DocAccess code. Complex documents may take slightly longer for our quality review process.

What about documents on external sites we link to?

DocAccess uniquely handles external PDFs you link to, ensuring your users have an accessible experience even with third-party documents.

Is this solution legally compliant?

DocAccess meets all federal ADA requirements and state-specific regulations for accessible document creation. No customer using DocAccess has paid even a dollar for any ADA lawsuit, claim, or fine related to its documents. If you encounter an issue, contact us immediately so we can assist you with our unlimited accessibility and legal support program.

Service Agreement

This Software as a Service Agreement ("Agreement") is entered into on **April 13, 2026**, between CivicPlus, LLC ("Provider") and **Stillwater Area Public School District, OK** ("Customer").

Services Provided

DocAccess is a subscription-based accessibility solution that includes:

- Automated document accessibility compliance
- Real-time translation to 250 languages
- AI-powered search and Q&A functionality
- 24/7 live visual interpretation services
- Compliance monitoring and reporting

Subscription

- **K12 Education - 5,687 Students Plan - Publicly Available PDFs and Course Materials On-Demand on stillwaterschools.org**

Terms

- **Fee: \$11,974 per year**
- **Contract Term: Apr 13, 2026 - Jun 30, 2027 - 5% annual uplift starting Year 2**
- **Payment Schedule: Every year, beginning July 1, 2026**
- **Payment Terms: Net 45**
- **Renewal Procedure: Automatic one-year renewal term, unless 60 days notice provided prior to renewal date**

Example Payment Schedule

Invoice	Dates of Service	Rate	Amount
Complimentary Service	4/13/2026 - 6/30/2026	Free	\$0
First Invoice	7/1/2026 - 6/30/2027	\$11,974/year	\$11,974
Future Invoice	7/1/2027 - 6/30/2028	\$11,974/year + 5% uplift	\$12,573

The CivicPlus accounting department will gladly work with you to adjust the payment schedule to meet your needs. Amounts will not include certain state or local imposed sales taxes. Proration amounts are approximate.

This Service Agreement is governed by the terms and conditions of the [Master Services Agreement](#) and the [DocAccess Terms and Conditions](#), both available at: <https://www.civicplus.help/docs/legal-terms-and-conditions-for-services> (collectively, the "Agreement"). By executing this Service Agreement, Customer acknowledges and agrees to be bound by all terms and conditions set forth in the Agreement referenced above. In the event a Master Services Agreement is already executed between the parties, the existing agreement shall take precedence over the linked Master Services Agreement.

Customer may issue purchase orders for its internal, administrative use only, and not to impose any contractual terms. Any terms contained in any such purchase orders issued by the Customer are considered null and will not alter the Binding Terms, the Agreement, or this service agreement.

CivicPlus, LLC



Name: Mac Clemmens
Title: SVP, DocAccess Co-Founder
Date: [signature_date]

Stillwater Area Public School District, OK

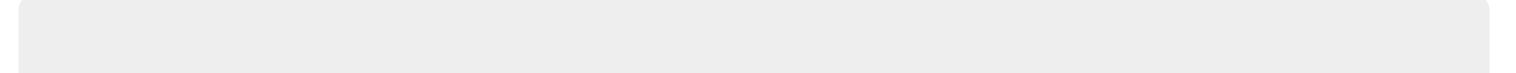

Name:
Title:
Date: [signature_date]

W-9 available at getstreamline.com/w9 | Fed Tax ID: 48-1202104



STILLWATER PUBLIC SCHOOLS
STILLWATER BOARD OF EDUCATION

PREPARED BY: Mrs. Kristie Newby, MBA, CFE, Chief Financial Officer
APPROVED BY: Mr. Tyler Bridges, Superintendent
DATE: April 14, 2026

AGENDA ITEM:

Treasurer's Report

BOARD ACTION REQUESTED:

Consider and Vote to approve Treasurer's report (which includes the monthly Bond Expenditures and Revenues Report) as of April 1, 2026.

BACKGROUND INFORMATION:

The Treasurer's Report is a monthly report is highlighting changes to existing Purchase Orders and activity thru April 1, 2026.

The monthly Bond Expenditures and Revenues Report for May 2025 provides an overview of the General Obligation Bond Issue approved on February 14, 2017 (Bond 31) and the General Obligation Bond Issue approved on February 14, 2023 (Bond 32/33).

Revenue Analysis

Options: Type of Revenue: Estimated, As Of Date: 3/31/2026

	Estimated Revenue	Revenue Collected	Revenue Receivable	Unappropriated Receipts	% Rev Collected	Current Month
Fund - 11 GENERAL FUND						
Series - 1000						
Source - 1110 AD VALOREM TAX LEVY (CURRENT YR)	\$0.00	\$18,966,233.01	\$0.00	\$18,966,233.01	N/A	\$669,752.71
Source - 1120 AD VALOREM TAX LEVY (PRIOR YRS)	\$0.00	\$316,301.35	\$0.00	\$316,301.35	N/A	\$34,014.33
Source - 1130 REVENUE IN LIEU OF TAXES	\$0.00	\$133,262.05	\$0.00	\$133,262.05	N/A	\$36,175.13
Source - 1310 INTEREST EARNINGS	\$0.00	\$474,008.42	\$0.00	\$474,008.42	N/A	\$83,410.96
Source - 1350 INTEREST ON TAXES	\$0.00	\$26,746.05	\$0.00	\$26,746.05	N/A	\$19,254.98
Source - 1410 RENTAL OF SCHOOL FACILITIES	\$0.00	\$31,385.15	\$0.00	\$31,385.15	N/A	\$2,842.30
Source - 1420 RENTAL NOT SCHOOL FACILITIES	\$0.00	\$25.00	\$0.00	\$25.00	N/A	\$0.00
Source - 1510 INSURANCE LOSS RECOVERIES	\$0.00	\$6,594.87	\$0.00	\$6,594.87	N/A	\$0.00
Source - 1520 LIFE INSURANCE PREMIUM REIMBURSE	\$0.00	\$0.00	\$0.00	\$0.00	N/A	\$0.00
Source - 1590 MISCELLANEOUS REIMBURSEMENTS	\$0.00	\$604,671.06	\$0.00	\$604,671.06	N/A	\$33,539.13
Source - 1710 STUDENT LUNCHS/BREAKFASTS/MILK	\$0.00	\$0.00	\$0.00	\$0.00	N/A	\$0.00
Source - 1720 A LA CARTE OR CATERING REVENUE	\$0.00	\$0.00	\$0.00	\$0.00	N/A	\$0.00
Source - 1730 ADULT LUNCHES/BREAKFASTS	\$0.00	\$0.00	\$0.00	\$0.00	N/A	\$0.00
Series - 1000 Total	\$0.00	\$20,559,226.96	\$0.00	\$20,559,226.96	N/A	\$878,989.54
Series - 2000						
Source - 2100 COUNTY 4 MILL AD VALOREM TAX	\$0.00	\$2,292,635.74	\$0.00	\$2,292,635.74	N/A	\$72,988.68
Source - 2200 COUNTY APPORTIONMENT (MORTGAGE TAX)	\$0.00	\$267,439.80	\$0.00	\$267,439.80	N/A	\$30,097.43
Series - 2000 Total	\$0.00	\$2,560,075.54	\$0.00	\$2,560,075.54	N/A	\$103,086.11
Series - 3000						
Source - 3110 GROSS PRODUCTION TAX	\$0.00	\$120,633.59	\$0.00	\$120,633.59	N/A	\$11,989.27
Source - 3120 MOTOR VEHICLE COLLECTIONS	\$0.00	\$1,832,070.04	\$0.00	\$1,832,070.04	N/A	\$209,935.10
Source - 3130 RURAL ELECTRIC COOPERATIVE TAX	\$0.00	\$177,733.55	\$0.00	\$177,733.55	N/A	\$22,347.29
Source - 3140 STATE SCHOOL LAND EARNINGS	\$0.00	\$821,934.93	\$0.00	\$821,934.93	N/A	\$93,696.82
Source - 3150 VEHICLE TAX STAMP	\$0.00	\$3,871.78	\$0.00	\$3,871.78	N/A	\$681.09
Source - 3160 FARM IMPLEMENT TAX STAMP	\$0.00	\$3,343.67	\$0.00	\$3,343.67	N/A	\$1,322.02
Source - 3210 FOUNDATION AND SALARY INCENT AID	\$0.00	\$12,518,837.98	\$0.00	\$12,518,837.98	N/A	\$1,564,725.46
Source - 3250 EDUCATION FLEX BENEFIT ALLOWANCE	\$0.00	\$3,590,015.69	\$0.00	\$3,590,015.69	N/A	\$520,538.49
Source - 3310 ALTERNATIVE & HIGH CHALLENGE EDU	\$0.00	\$142,660.56	\$0.00	\$142,660.56	N/A	\$50,927.78
Source - 3412 NATIONAL BOARD CERTIFIED BONUS	\$0.00	\$45,200.00	\$0.00	\$45,200.00	N/A	\$0.00
Source - 3415 STRONG READERS	\$0.00	\$91,717.01	\$0.00	\$91,717.01	N/A	\$0.00
Source - 3420 STATE TEXTBOOK	\$0.00	\$275,749.21	\$0.00	\$275,749.21	N/A	\$34,468.65
Source - 3436 SCHOOL RESOURCE OFFICER PROGRAM	\$0.00	\$93,041.47	\$0.00	\$93,041.47	N/A	\$0.00
Source - 3620 STATE LAND REIMBURSEMENT	\$0.00	\$411.45	\$0.00	\$411.45	N/A	\$0.00
Source - 3690 OTHER MISC SOURCES OF STATE REVENUE	\$0.00	\$256,250.00	\$0.00	\$256,250.00	N/A	\$50,000.00

Stillwater Public Schools

Revenue Analysis

Options: Type of Revenue: Estimated, As Of Date: 3/31/2026

	Estimated Revenue	Revenue Collected	Revenue Receivable	Unappropriated Receipts	% Rev Collected	Current Month
Source - 3720 STATE MATCHING	\$0.00	\$0.00	\$0.00	\$0.00	N/A	\$0.00
Source - 3811 COMP HS VOCATIONAL SAL REIMB	\$0.00	\$37,670.00	\$0.00	\$37,670.00	N/A	\$5,940.00
Source - 3812 VOCATIONAL PROGRAM ASSISTANCE GRANT	\$0.00	\$138,561.00	\$0.00	\$138,561.00	N/A	\$46,187.00
Series - 3000 Total	\$0.00	\$20,149,701.93	\$0.00	\$20,149,701.93	N/A	\$2,612,758.97
Series - 4000						
Source - 4140 TITLE VI INDIAN, NATIVE HI/AK EDU	\$0.00	\$101,089.93	\$0.00	\$101,089.93	N/A	\$26,953.84
Source - 4164 SUB-MARGINAL LANDS	\$0.00	\$788.72	\$0.00	\$788.72	N/A	\$0.00
Source - 4210 TITLE I-PART A- IMPROVING BASIC PROG	\$0.00	\$779,252.32	\$0.00	\$779,252.32	N/A	\$116,191.94
Source - 4271 PART A, SUPPORTING EFFECTIVE INST	\$0.00	\$93,232.82	\$0.00	\$93,232.82	N/A	\$58,287.06
Source - 4281 TITLE III PT A ENG LANG ACQUISITION	\$0.00	\$15,336.47	\$0.00	\$15,336.47	N/A	\$1,239.54
Source - 4310 INDIVIDUALS WITH DISABIL IDEA--B	\$0.00	\$785,928.77	\$0.00	\$785,928.77	N/A	\$1,325.00
Source - 4340 PRESCHOOL AGES 3-5 IDEA-B	\$0.00	\$20,757.24	\$0.00	\$20,757.24	N/A	\$0.00
Source - 4442 STUDENT SUPPORT & ACADEMIC ENRICH	\$0.00	\$38,053.01	\$0.00	\$38,053.01	N/A	\$5,384.15
Source - 4470 TITLE VI-SUB 2- RURAL/LOW INCOME SCH	\$0.00	\$65,788.06	\$0.00	\$65,788.06	N/A	\$8,730.60
Source - 4480 TITLE IX- ED FOR HOMELESS/OTHER LAW	\$0.00	\$33,924.77	\$0.00	\$33,924.77	N/A	\$10,939.74
Source - 4580 MEDICAID RESOURCES	\$0.00	\$97,617.98	\$0.00	\$97,617.98	N/A	\$26,761.50
Source - 4710 LUNCHES	\$0.00	\$0.00	\$0.00	\$0.00	N/A	\$0.00
Source - 4720 BREAKFASTS	\$0.00	\$0.00	\$0.00	\$0.00	N/A	\$0.00
Series - 4000 Total	\$0.00	\$2,031,770.09	\$0.00	\$2,031,770.09	N/A	\$255,813.37
Series - 6000						
Source - 6110 CASH FORWARD	\$0.00	\$7,653,287.98	\$0.00	\$7,653,287.98	N/A	\$0.00
Series - 6000 Total	\$0.00	\$7,653,287.98	\$0.00	\$7,653,287.98	N/A	\$0.00
Fund - 11 GENERAL FUND Total	\$0.00	\$52,954,062.50	\$0.00	\$52,954,062.50	N/A	\$3,850,647.99

Revenue Analysis

Options: Type of Revenue: Estimated, As Of Date: 3/31/2026

	Estimated Revenue	Revenue Collected	Revenue Receivable	Unappropriated Receipts	% Rev Collected	Current Month
Fund - 21 BUILDING FUND						
Series - 1000						
Source - 1110 AD VALOREM TAX LEVY (CURRENT YR)	\$0.00	\$2,710,213.96	\$0.00	\$2,710,213.96	N/A	\$95,705.56
Source - 1120 AD VALOREM TAX LEVY (PRIOR YRS)	\$0.00	\$45,198.44	\$0.00	\$45,198.44	N/A	\$4,860.54
Source - 1590 MISCELLANEOUS REIMBURSEMENTS	\$0.00	\$53,113.73	\$0.00	\$53,113.73	N/A	\$0.00
Series - 1000 Total	\$0.00	\$2,808,526.13	\$0.00	\$2,808,526.13	N/A	\$100,566.10
Series - 3000						
Source - 3160 FARM IMPLEMENT TAX STAMP	\$0.00	\$477.82	\$0.00	\$477.82	N/A	\$188.92
Source - 3250 EDUCATION FLEX BENEFIT ALLOWANCE	\$0.00	\$200,260.82	\$0.00	\$200,260.82	N/A	\$28,522.86
Source - 3620 STATE LAND REIMBURSEMENT	\$0.00	\$58.80	\$0.00	\$58.80	N/A	\$0.00
Series - 3000 Total	\$0.00	\$200,797.44	\$0.00	\$200,797.44	N/A	\$28,711.78
Series - 6000						
Source - 6110 CASH FORWARD	\$0.00	\$2,486,751.18	\$0.00	\$2,486,751.18	N/A	\$0.00
Series - 6000 Total	\$0.00	\$2,486,751.18	\$0.00	\$2,486,751.18	N/A	\$0.00
Fund - 21 BUILDING FUND Total	\$0.00	\$5,496,074.75	\$0.00	\$5,496,074.75	N/A	\$129,277.88

Stillwater Public Schools

Revenue Analysis

Options: Type of Revenue: Estimated, As Of Date: 3/31/2026

	Estimated Revenue	Revenue Collected	Revenue Receivable	Unappropriated Receipts	% Rev Collected	Current Month
Fund - 22 CHILD NUTRITION PROGRAMS FUND						
Series - 1000						
Source - 1310 INTEREST EARNINGS	\$0.00	\$212.49	\$0.00	\$212.49	N/A	\$87.02
Source - 1590 MISCELLANEOUS REIMBURSEMENTS	\$0.00	\$1,376.00	\$0.00	\$1,376.00	N/A	\$0.00
Source - 1710 STUDENT LUNCHES/BREAKFASTS/MILK	\$0.00	\$390,728.62	\$0.00	\$390,728.62	N/A	\$47,565.38
Source - 1720 A LA CARTE OR CATERING REVENUE	\$0.00	\$137,667.66	\$0.00	\$137,667.66	N/A	\$17,239.44
Source - 1730 ADULT LUNCHES/BREAKFASTS	\$0.00	\$15,681.11	\$0.00	\$15,681.11	N/A	\$1,962.97
Source - 1790 OTHER DIST REVENUE (CHILD NUTRIT)	\$0.00	\$186.51	\$0.00	\$186.51	N/A	\$0.00
Series - 1000 Total	\$0.00	\$545,852.39	\$0.00	\$545,852.39	N/A	\$66,854.81
Series - 3000						
Source - 3250 EDUCATION FLEX BENEFIT ALLOWANCE	\$0.00	\$234,088.17	\$0.00	\$234,088.17	N/A	\$33,138.11
Source - 3710 STATE REIMBURSEMENT	\$0.00	\$7,941.16	\$0.00	\$7,941.16	N/A	\$0.00
Source - 3720 STATE MATCHING	\$0.00	\$17,278.75	\$0.00	\$17,278.75	N/A	\$0.00
Series - 3000 Total	\$0.00	\$259,308.08	\$0.00	\$259,308.08	N/A	\$33,138.11
Series - 4000						
Source - 4710 LUNCHES	\$0.00	\$1,210,693.53	\$0.00	\$1,210,693.53	N/A	\$193,520.71
Source - 4720 BREAKFASTS	\$0.00	\$490,703.12	\$0.00	\$490,703.12	N/A	\$77,730.32
Source - 4740 SUMMER FOOD SERVICE PROGRAM	\$0.00	\$286,154.52	\$0.00	\$286,154.52	N/A	\$0.00
Series - 4000 Total	\$0.00	\$1,987,551.17	\$0.00	\$1,987,551.17	N/A	\$271,251.03
Series - 6000						
Source - 6110 CASH FORWARD	\$0.00	\$1,305,180.19	\$0.00	\$1,305,180.19	N/A	\$0.00
Series - 6000 Total	\$0.00	\$1,305,180.19	\$0.00	\$1,305,180.19	N/A	\$0.00
Fund - 22 CHILD NUTRITION PROGRAMS FUND Total	\$0.00	\$4,097,891.83	\$0.00	\$4,097,891.83	N/A	\$371,243.95

Stillwater Public Schools

Revenue Analysis

Options: Type of Revenue: Estimated, As Of Date: 3/31/2026

	Estimated Revenue	Revenue Collected	Revenue Receivable	Unappropriated Receipts	% Rev Collected	Current Month
Fund - 31 BOND FUND 31						
Series - 6000						
Source - 6110 CASH FORWARD	\$0.00	\$1,085,835.29	\$0.00	\$1,085,835.29	N/A	\$0.00
Series - 6000 Total	\$0.00	\$1,085,835.29	\$0.00	\$1,085,835.29	N/A	\$0.00
Fund - 31 BOND FUND 31 Total	\$0.00	\$1,085,835.29	\$0.00	\$1,085,835.29	N/A	\$0.00

Revenue Analysis

Options: Type of Revenue: Estimated, As Of Date: 3/31/2026

	Estimated Revenue	Revenue Collected	Revenue Receivable	Unappropriated Receipts	% Rev Collected	Current Month
Fund - 32 BOND FUND 32						
Series - 1000						
Source - 1310 INTEREST EARNINGS	\$0.00	\$1,075.20	\$0.00	\$1,075.20	N/A	\$0.00
Series - 1000 Total	\$0.00	\$1,075.20	\$0.00	\$1,075.20	N/A	\$0.00
Series - 6000						
Source - 6110 CASH FORWARD	\$0.00	\$9,261,435.86	\$0.00	\$9,261,435.86	N/A	\$0.00
Series - 6000 Total	\$0.00	\$9,261,435.86	\$0.00	\$9,261,435.86	N/A	\$0.00
Fund - 32 BOND FUND 32 Total	\$0.00	\$9,262,511.06	\$0.00	\$9,262,511.06	N/A	\$0.00

Stillwater Public Schools

Revenue Analysis

Options: Type of Revenue: Estimated, As Of Date: 3/31/2026

	Estimated Revenue	Revenue Collected	Revenue Receivable	Unappropriated Receipts	% Rev Collected	Current Month
Fund - 33 BOND FUND 33						
Series - 6000						
Source - 6110 CASH FORWARD	\$0.00	\$10,761,950.75	\$0.00	\$10,761,950.75	N/A	\$0.00
Series - 6000 Total	\$0.00	\$10,761,950.75	\$0.00	\$10,761,950.75	N/A	\$0.00
Fund - 33 BOND FUND 33 Total	\$0.00	\$10,761,950.75	\$0.00	\$10,761,950.75	N/A	\$0.00

Revenue Analysis

Options: Type of Revenue: Estimated, As Of Date: 3/31/2026

	Estimated Revenue	Revenue Collected	Revenue Receivable	Unappropriated Receipts	% Rev Collected	Current Month
Fund - 41 SINKING FUND						
Series - 1000						
Source - 1110 AD VALOREM TAX LEVY (CURRENT YR)	\$0.00	\$13,161,494.03	\$0.00	\$13,161,494.03	N/A	\$464,752.63
Source - 1120 AD VALOREM TAX LEVY (PRIOR YRS)	\$0.00	\$231,237.42	\$0.00	\$231,237.42	N/A	\$24,960.35
Source - 1310 INTEREST EARNINGS	\$0.00	\$587,871.37	\$0.00	\$587,871.37	N/A	\$87,527.36
Series - 1000 Total	\$0.00	\$13,980,602.82	\$0.00	\$13,980,602.82	N/A	\$577,240.34
Series - 3000						
Source - 3160 FARM IMPLEMENT TAX STAMP	\$0.00	\$2,385.76	\$0.00	\$2,385.76	N/A	\$917.43
Source - 3620 STATE LAND REIMBURSEMENT	\$0.00	\$285.54	\$0.00	\$285.54	N/A	\$0.00
Series - 3000 Total	\$0.00	\$2,671.30	\$0.00	\$2,671.30	N/A	\$917.43
Series - 6000						
Source - 6110 CASH FORWARD	\$0.00	\$9,631,092.03	\$0.00	\$9,631,092.03	N/A	\$0.00
Series - 6000 Total	\$0.00	\$9,631,092.03	\$0.00	\$9,631,092.03	N/A	\$0.00
Fund - 41 SINKING FUND Total	\$0.00	\$23,614,366.15	\$0.00	\$23,614,366.15	N/A	\$578,157.77

Stillwater Public Schools

Revenue Analysis

Options: Type of Revenue: Estimated, As Of Date: 3/31/2026

	Estimated Revenue	Revenue Collected	Revenue Receivable	Unappropriated Receipts	% Rev Collected	Current Month
Fund - 81 GIFT FUND						
Series - 1000						
Source - 1610	\$0.00	\$600,000.00	\$0.00	\$600,000.00	N/A	\$0.00
CONTRIBUTIONS/DONATIONS-PRIVATE						
Series - 1000 Total	\$0.00	\$600,000.00	\$0.00	\$600,000.00	N/A	\$0.00
Fund - 81 GIFT FUND Total	\$0.00	\$600,000.00	\$0.00	\$600,000.00	N/A	\$0.00

Stillwater Public Schools

Revenue Analysis

Options: Type of Revenue: Estimated, As Of Date: 3/31/2026

	Estimated Revenue	Revenue Collected	Revenue Receivable	Unappropriated Receipts	% Rev Collected	Current Month
Report Total	\$0.00	\$107,872,692.33	\$0.00	\$107,872,692.33	N/A	\$4,929,327.59

Budget Analysis

Options: Year: 2025-2026, Date Range: 7/1/2025 - 3/31/2026, Print Detail: False

Classification	Appropriation	Encumbered	Paid	Encumbered Balance	Unencumbered Balance	% Enc Budget
2025-2026						
Fund - 11 GENERAL FUND						
000 NON-CATEGORICAL	552,964.31	1,683.07	1,683.07	0.00	551,281.24	0.30%
001 HIGH SCHOOL	7,500.00	5,769.06	4,369.06	1,400.00	1,730.94	76.92%
002 JUNIOR HIGH	7,500.00	1,329.00	1,329.00	0.00	6,171.00	17.72%
003 MIDDLE SCHOOL	6,770.00	6,452.81	5,363.33	1,089.48	317.19	95.31%
004 HIGHLAND PARK	5,000.00	390.00	390.00	0.00	4,610.00	7.80%
005 RICHMOND	5,000.00	1,537.50	0.00	1,537.50	3,462.50	30.75%
006 SANGRE RIDGE	5,000.00	1,954.75	1,954.75	0.00	3,045.25	39.10%
007 SKYLINE	6,330.00	2,418.89	2,362.89	56.00	3,911.11	38.21%
008 WESTWOOD	5,000.00	4,993.97	4,860.00	133.97	6.03	99.88%
009 WILL ROGERS	5,055.00	5,038.14	5,038.14	0.00	16.86	99.67%
010 LINCOLN ACADEMY	3,495.00	2,328.42	1,187.50	1,140.92	1,166.58	66.62%
011 CURRICULUM & INSTRUCTIONAL	81,515.00	39,508.53	23,708.83	15,799.70	42,006.47	48.47%
012 NURSE & OSHA SUPPLIES	4,250.00	3,506.09	3,402.99	103.10	743.91	82.50%
013 ED SERVICES SUPPLIES	1,000.00	999.72	701.93	297.79	0.28	99.97%
014 CUSTODIAL SUPPLIES	95,500.00	95,320.22	93,077.62	2,242.60	179.78	99.81%
015 ADMIN OPERATIONS SUPPLIES	2,000.00	250.00	250.00	0.00	1,750.00	12.50%
016 DISTRICT SUPPLIES	50,000.00	47,925.72	47,925.72	0.00	2,074.28	95.85%
017 AVIATION GRANT	14,650.00	8,930.33	5,637.33	3,293.00	5,719.67	60.96%
018 CONTRACTED SOCIAL SERVICES	288,000.00	280,000.00	139,993.96	140,006.04	8,000.00	97.22%
019 LIBRARY	45,759.00	45,545.87	36,012.71	9,533.16	213.13	99.53%
020 CAREERTECH GRANT-FEDERAL STRENGTHENING	25,000.00	24,439.82	17,390.30	7,049.52	560.18	97.76%
021 SUMMER SCHOOL	39,100.00	17,472.15	17,472.15	0.00	21,627.85	44.69%
022 EXTENDED SCHOOL YEAR	11,220.00	3,922.78	3,922.78	0.00	7,297.22	34.96%
023 PR AND COMMUNICATIONS	5,100.00	1,562.98	1,412.98	150.00	3,537.02	30.65%
024 BAND	27,150.00	26,826.70	18,416.55	8,410.15	323.30	98.81%
025 ORCHESTRA	10,200.00	10,200.00	0.00	10,200.00	0.00	100.00%
026 LEGAL SERVICES	120,000.00	111,781.97	44,428.47	67,353.50	8,218.03	93.15%
027 AUDIT SERVICES	16,100.00	16,100.00	14,100.00	2,000.00	0.00	100.00%
028 POSTAGE & FREIGHT	23,700.00	23,700.00	15,376.54	8,323.46	0.00	100.00%
029 BOE/CABINET PROFESSIONAL DEVELOPMENT	42,500.00	22,327.50	7,002.50	15,325.00	20,172.50	52.54%
030 FACILITIES MISCELLANEOUS	17,235.56	15,971.46	2,001.46	13,970.00	1,264.10	92.67%
031 BOE GENERAL EXPENSES	12,977.00	12,977.00	12,977.00	0.00	0.00	100.00%
032 FINANCE	135,000.00	9,746.23	6,794.08	2,952.15	125,253.77	7.22%
033 BOARD ELECTION/BOND FEES	76,000.00	25,109.78	13,765.52	11,344.26	50,890.22	33.04%
034 SPED TESTING	19,826.25	19,826.25	19,826.25	0.00	0.00	100.00%
035 BOE/SUPERINTENDENT SUPPLIES	5,000.00	1,160.98	960.98	200.00	3,839.02	23.22%
036 MILEAGE EXPENSE-NO DIST TRANSP AVAIL (CFO AUTH)	2,000.00	2,000.00	0.00	2,000.00	0.00	100.00%
037 NON-REIMBURSABLE FEDERAL PROGRAMS EXPENSES	50.00	50.00	50.00	0.00	0.00	100.00%

Budget Analysis

Options: Year: 2025-2026, Date Range: 7/1/2025 - 3/31/2026, Print Detail: False

Classification	Appropriation	Encumbered	Paid	Encumbered Balance	Unencumbered Balance	% Enc Budget
2025-2026						
Fund - 11 GENERAL FUND						
040 TIER II SPECIAL NEEDS	120,000.00	0.00	0.00	0.00	120,000.00	0.00%
041 DISTRICT SUPPLIES-ELEMENTARY REIMBURSEABLE	83,000.00	81,376.98	81,376.98	0.00	1,623.02	98.04%
042 HUMAN RESOURCES	528,501.00	525,751.92	496,465.14	29,286.78	2,749.08	99.48%
045 FLEET FUEL	250,000.00	250,000.00	165,262.30	84,737.70	0.00	100.00%
047 DISTRICT WIDE TRANSPORTATION	189,825.00	186,445.39	84,110.77	102,334.62	3,379.61	98.22%
048 TRANSPORTATION MISCELLANEOUS	47,305.00	37,130.41	11,857.82	25,272.59	10,174.59	78.49%
049 UTILITIES-ELECTRICITY	1,024,000.00	910,240.45	846,012.46	64,227.99	113,759.55	88.89%
051 UTILITIES-GAS	348,500.00	348,500.00	164,023.91	184,476.09	0.00	100.00%
052 UTILITIES-TELEPHONE/INTERNET	152,000.00	151,273.43	130,648.43	20,625.00	726.57	99.52%
053 UTILITIES-WATER/TRASH	392,800.00	392,800.00	244,674.38	148,125.62	0.00	100.00%
054 BUILDING MAINTENANCE	177,000.00	77,521.44	22,718.14	54,803.30	99,478.56	43.80%
055 GROUNDS	48,450.00	20,300.31	1,194.95	19,105.36	28,149.69	41.90%
056 VOCAL MUSIC	1,020.00	1,000.98	755.98	245.00	19.02	98.14%
057 DRAMA	4,250.00	4,011.98	2,550.98	1,461.00	238.02	94.40%
058 ATHLETICS	83,300.00	4,448.29	4,448.29	0.00	78,851.71	5.34%
060 PROFESSIONAL DEVELOPMENT	60,000.00	28,700.97	11,255.97	17,445.00	31,299.03	47.83%
061 LIABILITY BONDS	4,935.50	4,835.50	4,607.50	228.00	100.00	97.97%
064 PROPERTY INSURANCE	1,451,908.00	1,451,908.00	1,451,908.00	0.00	0.00	100.00%
065 HIGH SCHOOL GRADUATION	36,887.00	36,886.55	2,392.45	34,494.10	0.45	100.00%
066 PERFORMING ARTS CENTER	3,187.50	1,485.00	945.00	540.00	1,702.50	46.59%
067 COUNTY RE-EVALUATION	430,250.00	425,108.00	108.00	425,000.00	5,142.00	98.80%
072 SECURITY	133,000.00	132,141.00	111,182.17	20,958.83	859.00	99.35%
086 RSI	62,056.98	8,122.00	2,000.00	6,122.00	53,934.98	13.09%
087 MTSS GRANT NON-PAYROLL EXPENSES	343,388.52	56,502.55	26,538.62	29,963.93	286,885.97	16.45%
088 OPIOID ABATEMENT GRANT NON-PAYROLL EXPENSES	25,000.00	18,750.00	17,590.00	1,160.00	6,250.00	75.00%
092 TECHNOLOGY MISCELLANEOUS	28,067.43	15,947.43	15,947.43	0.00	12,120.00	56.82%
100 MAIN PERSONNEL	36,524,000.00	36,385,283.19	23,079,938.74	13,305,344.45	138,716.81	99.62%
101 FACILITIES PERSONNEL	1,200,000.00	1,082,367.74	864,014.56	218,353.18	117,632.26	90.20%
102 EAS/CREDIT RECOVERY PERSONNEL	10,000.00	0.00	0.00	0.00	10,000.00	0.00%
103 HOMEBOUND SERVICES PERSONNEL	26,000.00	8,523.59	8,523.59	0.00	17,476.41	32.78%
104 CLASSROOM COVER PERSONNEL	15,000.00	12,599.50	12,599.50	0.00	2,400.50	84.00%
105 NATIONAL BOARD CERTIFIED BONUS -DISTRICT PAID	11,000.00	0.00	0.00	0.00	11,000.00	0.00%
106 NON-FUNDED CAREERTECH PERSONNEL COSTS	1,386,200.00	1,386,089.00	938,635.75	447,453.25	111.00	99.99%
110 PALS PERSONNEL	200,000.00	179,150.71	121,697.00	57,453.71	20,849.29	89.58%
111 ACTIVITY FUND PAID PERSONNEL	226,260.81	165,945.00	115,794.41	50,150.59	60,315.81	73.34%
112 MTSS GRANT PERSONNEL	190,100.00	186,154.42	149,671.59	36,482.83	3,945.58	97.92%
114 OPIOID ABATEMENT GRANT PERSONNEL	50,000.00	50,000.00	44,911.92	5,088.08	0.00	100.00%

Budget Analysis

Options: Year: 2025-2026, Date Range: 7/1/2025 - 3/31/2026, Print Detail: False

Classification	Appropriation	Encumbered	Paid	Encumbered Balance	Unencumbered Balance	% Enc Budget
2025-2026						
Fund - 11 GENERAL FUND						
312 NATIONAL BOARD CERTIFIED BONUS -STATE PAID	70,000.00	45,180.62	45,180.62	0.00	24,819.38	64.54%
331 ED FLEX BENEFIT-CERTIFIED IN LIEU OF	73,613.76	54,304.09	34,157.90	20,146.19	19,309.67	73.77%
332 ED FLEX BENEFIT-SUPPORT IN LIEU OF	213,879.27	178,877.67	125,385.09	53,492.58	35,001.60	83.63%
333 STATE TEXTBOOKS	467,167.62	18,892.64	0.00	18,892.64	448,274.98	4.04%
334 ED FLEX BENEFIT-CERTIFIED MED PD BY STATE	3,580,248.00	3,290,378.00	1,967,581.00	1,322,797.00	289,870.00	91.90%
335 ED FLEX BENEFIT-SUPPORT MED PD BY STATE	1,557,662.40	1,469,473.62	1,004,267.62	465,206.00	88,188.78	94.34%
361 ACHIEVING CLASSROOM EXCELLENCE (ACE) TECHNOLOGY	158,079.36	1,635.00	0.00	1,635.00	156,444.36	1.03%
367 STRONG READERS	242,691.68	132,983.26	19,779.14	113,204.12	109,708.42	54.80%
376 SCHOOL RESOURCE OFFICER	216,473.62	112,454.62	99,912.12	12,542.50	104,019.00	51.95%
388 ALTERNATIVE EDUCATION	93,583.21	93,583.21	58,073.00	35,510.21	0.00	100.00%
411 OK CAREERTECH=COMPREHENSIVE SECONDARY PROGRAMS	63,460.00	63,456.00	50,953.11	12,502.89	4.00	99.99%
412 OK CAREERTECH-VOCATIONAL PROGRAMS ASSISTANCE	187,000.00	183,336.78	118,411.36	64,925.42	3,663.22	98.04%
511 TITLE I, PART A (BASIC PROGRAM)	1,753,893.40	1,392,085.21	786,963.72	605,121.49	361,808.19	79.37%
515 TITLE I (SCHOOL SUPPORT)	1,964.11	1,964.11	1,964.11	0.00	0.00	100.00%
518 TITLE I, PART A, SUBPART 2 (NEGLECTED, LEAS)	27,809.65	16,225.70	4,261.71	11,963.99	11,583.95	58.35%
541 TITLE II, PART A (SUPPORT EFFECTIVE INSTRUCTION)	287,073.70	161,788.09	119,096.70	42,691.39	125,285.61	56.36%
552 TITLE IV, PART A (STU SUP & ACAD ENRICH FRM GRANT)	163,217.35	62,771.24	38,554.93	24,216.31	100,446.11	38.46%
561 TITLE VI, PART A (INDIAN EDUCATION)	147,452.00	141,425.55	89,412.26	52,013.29	6,026.45	95.91%
571 TITLE III, PART A (IMMIGRANT EDUCATION ACT)	16,401.00	14,910.93	9,907.00	5,003.93	1,490.07	90.91%
572 TITLE III, PART A (ENG LANG ACQ, ENH & ACHEIVE)	64,368.09	14,935.58	8,440.25	6,495.33	49,432.51	23.20%
587 TITLE V, PART B, SUBPRT 2 (RURAL/LOW INC SCHL PGM)	156,300.39	83,494.18	65,045.32	18,448.86	72,806.21	53.42%
596 TITLE IX, PART A (HOMELESS CHILDREN & YOUTH)	77,018.22	54,533.22	34,484.27	20,048.95	22,485.00	70.81%
613 IDEA PART B (SPED PROF DEVELOP OSDE SPONSORED)	7,800.00	6,879.00	6,879.00	0.00	921.00	88.19%
615 IDEA PART B (SPED PROF DEVELOP DISTRICT)	4,432.00	4,115.00	3,815.00	300.00	317.00	92.85%
616 IDEA PART B (SUB AREA CERT EXAM REIMBURSE)	430.00	286.05	286.05	0.00	143.95	66.52%
618 IDEA PART B (SECONDARY TRANS SERVICES)	25,098.26	7,849.48	5,166.97	2,682.51	17,248.78	31.27%

Budget Analysis

Options: Year: 2025-2026, Date Range: 7/1/2025 - 3/31/2026, Print Detail: False

Classification	Appropriation	Encumbered	Paid	Encumbered Balance	Unencumbered Balance	% Enc Budget
2025-2026						
Fund - 11 GENERAL FUND						
621 IDEA PART B (FLOW THROUGH, P.L.108-446)	1,399,200.53	1,322,445.85	793,467.41	528,978.44	76,754.68	94.51%
625 IDEA PART B (FLOW THRU, P.L.108-446 PRIVATE SCHL)	13,643.09	11,000.00	8,000.00	3,000.00	2,643.09	80.63%
627 IDEA PART B (FLOW THRU, P.L.108-446 HGH ND TR II)	52,915.07	52,859.45	32,966.88	19,892.57	55.62	99.89%
641 IDEA PART B (PRESCHOOL, AGED 3-5, P.L. 108-446)	34,084.56	34,084.56	34,084.56	0.00	0.00	100.00%
697 MEDICAID FEDERAL MATCH	30,512.42	6,243.87	0.00	6,243.87	24,268.55	20.46%
698 MEDICAID RESOURCES	64,522.25	62,032.43	24,692.90	37,339.53	2,489.82	96.14%
713 NATIVE YOUTH COMMUNITY PROJECT (NYCP) GRANT	85,612.21	0.00	0.00	0.00	85,612.21	0.00%
725 ARP ESSER III Student Teacher Stipend	8,752.92	8,752.92	8,752.92	0.00	0.00	100.00%
Total Fund - 11 GENERAL FUND	\$58,994,000.00	\$54,633,597.35	\$35,411,452.04	\$19,222,145.31	\$4,360,402.65	92.61 %

Budget Analysis

Options: Year: 2025-2026, Date Range: 7/1/2025 - 3/31/2026, Print Detail: False

Classification	Appropriation	Encumbered	Paid	Encumbered Balance	Unencumbered Balance	% Enc Budget
2025-2026						
Fund - 21 BUILDING FUND						
000 NON-CATEGORICAL	689,666.46	0.00	0.00	0.00	689,666.46	0.00%
030 FACILITIES MISCELLANEOUS	7,420.54	7,420.54	7,420.54	0.00	0.00	100.00%
032 FINANCE	3,000.00	3,000.00	3,000.00	0.00	0.00	100.00%
049 UTILITIES-ELECTRICITY	264,000.00	264,000.00	0.00	264,000.00	0.00	100.00%
051 UTILITIES-GAS	28,000.00	28,000.00	0.00	28,000.00	0.00	100.00%
053 UTILITIES-WATER/TRASH	50,000.00	50,000.00	0.00	50,000.00	0.00	100.00%
054 BUILDING MAINTENANCE	15,469.00	10,267.46	9,231.01	1,036.45	5,201.54	66.37%
055 GROUNDS	28,077.00	0.00	0.00	0.00	28,077.00	0.00%
100 MAIN PERSONNEL	260,000.00	254,018.81	183,321.32	70,697.49	5,981.19	97.70%
101 FACILITIES PERSONNEL	1,500,000.00	1,455,069.58	1,057,250.11	397,819.47	44,930.42	97.00%
332 ED FLEX BENEFIT-SUPPORT IN LIEU OF	21,123.00	17,261.79	12,519.54	4,742.25	3,861.21	81.72%
335 ED FLEX BENEFIT-SUPPORT MED PD BY STATE	281,244.00	250,985.00	180,285.00	70,700.00	30,259.00	89.24%
Total Fund - 21 BUILDING FUND	\$3,148,000.00	\$2,340,023.18	\$1,453,027.52	\$886,995.66	\$807,976.82	74.33 %

Budget Analysis

Options: Year: 2025-2026, Date Range: 7/1/2025 - 3/31/2026, Print Detail: False

Classification	Appropriation	Encumbered	Paid	Encumbered Balance	Unencumbered Balance	% Enc Budget
2025-2026						
Fund - 22 CHILD NUTRITION PROGRAMS FUND						
000 NON-CATEGORICAL	27,832.00	0.00	0.00	0.00	27,832.00	0.00%
049 UTILITIES-ELECTRICITY	28,320.30	28,320.30	28,320.30	0.00	0.00	100.00%
051 UTILITIES-GAS	8,976.66	8,976.66	8,976.66	0.00	0.00	100.00%
052 UTILITIES-TELEPHONE/INTERNET	2,600.00	0.00	0.00	0.00	2,600.00	0.00%
053 UTILITIES-WATER/TRASH	8,940.08	8,940.08	8,940.08	0.00	0.00	100.00%
064 PROPERTY INSURANCE	119,408.84	119,408.84	119,408.84	0.00	0.00	100.00%
091 LOCAL CHILD NUTRITION EXPENSES	172,130.00	149,456.90	102,685.88	46,771.02	22,673.10	86.83%
100 MAIN PERSONNEL	55,000.00	24,268.53	10,471.39	13,797.14	30,731.47	44.12%
101 FACILITIES PERSONNEL	43,500.00	3,597.71	3,597.71	0.00	39,902.29	8.27%
332 ED FLEX BENEFIT-SUPPORT IN LIEU OF	53,558.00	35,476.94	23,900.94	11,576.00	18,081.06	66.24%
335 ED FLEX BENEFIT-SUPPORT MED PD BY STATE	300,000.00	277,851.00	188,062.00	89,789.00	22,149.00	92.62%
385 CHILD NUTRITION PROGRAM	28,905.12	25,355.58	18,823.35	6,532.23	3,549.54	87.72%
763 LUNCHES	2,302,099.00	2,250,189.46	1,595,279.90	654,909.56	51,909.54	97.75%
764 BREAKFASTS	786,680.00	687,643.77	431,506.45	256,137.32	99,036.23	87.41%
766 SUMMER FOOD SERVICE PROGRAM	286,000.00	227,096.93	125,893.39	101,203.54	58,903.07	79.40%
767 PROF STANDARDS FOR SCHOOL NUTRITION EMPLOYEES	5,770.00	2,577.00	2,577.00	0.00	3,193.00	44.66%
Total Fund - 22 CHILD NUTRITION PROGRAMS FUND	\$4,229,720.00	\$3,849,159.70	\$2,668,443.89	\$1,180,715.81	\$380,560.30	91.00 %

Budget Analysis

Options: Year: 2025-2026, Date Range: 7/1/2025 - 3/31/2026, Print Detail: False

Classification	Appropriation	Encumbered	Paid	Encumbered Balance	Unencumbered Balance	% Enc Budget
2025-2026						
Fund - 31 BOND FUND 31						
000 NON-CATEGORICAL	138,937.91	0.00	0.00	0.00	138,937.91	0.00%
030 FACILITIES MISCELLANEOUS	50,837.71	50,837.71	18,793.96	32,043.75	0.00	100.00%
032 FINANCE	356,396.65	113,244.84	112,244.84	1,000.00	243,151.81	31.77%
047 DISTRICT WIDE TRANSPORTATION	256,123.52	254,755.52	254,755.52	0.00	1,368.00	99.47%
054 BUILDING MAINTENANCE	188,179.50	187,570.00	52,343.75	135,226.25	609.50	99.68%
055 GROUNDS	15,000.00	15,000.00	15,000.00	0.00	0.00	100.00%
071 BUILDING ACQUISITION/KICKER/OES REMODEL	80,360.00	12,106.53	12,106.53	0.00	68,253.47	15.07%
Total Fund - 31 BOND FUND 31	\$1,085,835.29	\$633,514.60	\$465,244.60	\$168,270.00	\$452,320.69	58.34 %

Budget Analysis

Options: Year: 2025-2026, Date Range: 7/1/2025 - 3/31/2026, Print Detail: False

Classification	Appropriation	Encumbered	Paid	Encumbered Balance	Unencumbered Balance	% Enc Budget
2025-2026						
Fund - 32 BOND FUND 32						
000 NON-CATEGORICAL	2,698.10	0.00	0.00	0.00	2,698.10	0.00%
011 CURRICULUM & INSTRUCTIONAL	360,086.79	0.00	0.00	0.00	360,086.79	0.00%
024 BAND	3.00	0.00	0.00	0.00	3.00	0.00%
032 FINANCE	433,633.40	0.00	0.00	0.00	433,633.40	0.00%
038 BOND-DW PRINTING/COPIERS	20,428.46	0.00	0.00	0.00	20,428.46	0.00%
047 DISTRICT WIDE TRANSPORTATION	433,458.80	431,380.46	431,380.46	0.00	2,078.34	99.52%
054 BUILDING MAINTENANCE	178,398.74	58,922.78	17,536.50	41,386.28	119,475.96	33.03%
055 GROUNDS	144,147.36	28,509.09	28,509.09	0.00	115,638.27	19.78%
058 ATHLETICS	79,087.82	50,507.48	31,403.80	19,103.68	28,580.34	63.86%
066 PERFORMING ARTS CENTER	50,000.00	0.00	0.00	0.00	50,000.00	0.00%
068 2023 BOND - HIGH SCHOOL PROJECT	2,795,520.97	2,153,676.32	488,388.01	1,665,288.31	641,844.65	77.04%
069 2023 BOND - ATHLETICS PROJECT	1,077,827.08	1,077,826.29	649,275.68	428,550.61	0.79	100.00%
071 BUILDING ACQUISITION/KICKER/OES REMODEL	765,947.62	314,251.51	314,251.51	0.00	451,696.11	41.03%
073 BOND-CLASSROOM TECHNOLOGY	242,351.54	0.00	0.00	0.00	242,351.54	0.00%
075 DISTRICT WIDE ROOF REPAIR	1,924,830.99	1,632,582.68	1,416,840.35	215,742.33	292,248.31	84.82%
076 BOND-CHROMEBOOKS & CARTS	522,209.33	0.00	0.00	0.00	522,209.33	0.00%
077 BOND-SUBSCRIPTIONS/LICENSING	90,298.31	0.00	0.00	0.00	90,298.31	0.00%
092 TECHNOLOGY MISCELLANEOUS	140,507.55	125,116.41	10,248.40	114,868.01	15,391.14	89.05%
Total Fund - 32 BOND FUND 32	\$9,261,435.86	\$5,872,773.02	\$3,387,833.80	\$2,484,939.22	\$3,388,662.84	63.41 %

Budget Analysis

Options: Year: 2025-2026, Date Range: 7/1/2025 - 3/31/2026, Print Detail: False

Classification	Appropriation	Encumbered	Paid	Encumbered Balance	Unencumbered Balance	% Enc Budget
2025-2026						
Fund - 33 BOND FUND 33						
000 NON-CATEGORICAL	28,221.75	0.00	0.00	0.00	28,221.75	0.00%
011 CURRICULUM & INSTRUCTIONAL	375,165.00	1,200.00	1,200.00	0.00	373,965.00	0.32%
024 BAND	100,210.00	100,203.70	0.00	100,203.70	6.30	99.99%
033 BOARD ELECTION/BOND FEES	12,500.00	6,500.00	3,500.00	3,000.00	6,000.00	52.00%
038 BOND-DW PRINTING/COPIERS	148,000.00	883.96	883.96	0.00	147,116.04	0.60%
047 DISTRICT WIDE TRANSPORTATION	477,225.00	380,208.46	376,960.50	3,247.96	97,016.54	79.67%
054 BUILDING MAINTENANCE	850,000.00	614,859.02	246,754.62	368,104.40	235,140.98	72.34%
055 GROUNDS	150,000.00	84,876.67	62,317.78	22,558.89	65,123.33	56.58%
058 ATHLETICS	75,000.00	41,385.00	41,385.00	0.00	33,615.00	55.18%
066 PERFORMING ARTS CENTER	50,000.00	24,692.12	13,796.96	10,895.16	25,307.88	49.38%
068 2023 BOND - HIGH SCHOOL PROJECT	4,533,642.00	733,418.44	10,840.39	722,578.05	3,800,223.56	16.18%
069 2023 BOND - ATHLETICS PROJECT	2,470,192.00	1,607,782.50	8,475.00	1,599,307.50	862,409.50	65.09%
073 BOND-CLASSROOM TECHNOLOGY	372,880.00	175,737.04	172,737.04	3,000.00	197,142.96	47.13%
076 BOND-CHROMEBOOKS & CARTS	250,000.00	164,839.60	164,839.60	0.00	85,160.40	65.94%
077 BOND-SUBSCRIPTIONS/LICENSING	168,915.00	152,555.23	152,555.23	0.00	16,359.77	90.31%
092 TECHNOLOGY MISCELLANEOUS	700,000.00	617,306.68	501,402.95	115,903.73	82,693.32	88.19%
Total Fund - 33 BOND FUND 33	\$10,761,950.75	\$4,706,448.42	\$1,757,649.03	\$2,948,799.39	\$6,055,502.33	43.73 %

Stillwater Public Schools Budget Analysis

Options: Year: 2025-2026, Date Range: 7/1/2025 - 3/31/2026, Print Detail: False

Classification	Appropriation	Encumbered	Paid	Encumbered Balance	Unencumbered Balance	% Enc Budget
2025-2026						
Fund - 41 SINKING FUND						
000 NON-CATEGORICAL	15,940,950.00	15,938,112.50	720,756.25	15,217,356.25	2,837.50	99.98%
Total Fund - 41 SINKING FUND	\$15,940,950.00	\$15,938,112.50	\$720,756.25	\$15,217,356.25	\$2,837.50	99.98 %

Budget Analysis

Options: Year: 2025-2026, Date Range: 7/1/2025 - 3/31/2026, Print Detail: False

Classification	Appropriation	Encumbered	Paid	Encumbered Balance	Unencumbered Balance	% Enc Budget
2025-2026						
Fund - 81 GIFT FUND						
201 GOOGLE DONATIONS-ED SERVICES	100,000.00	99,936.74	46,357.74	53,579.00	63.26	99.94%
202 GOOGLE DONATIONS-DISTRICT LIGHTING UPGRADES	500,000.00	500,000.00	371,519.00	128,481.00	0.00	100.00%
Total Fund - 81 GIFT FUND	\$600,000.00	\$599,936.74	\$417,876.74	\$182,060.00	\$63.26	99.99 %
Total 2025-2026	\$104,021,891.90	\$88,573,565.51	\$46,282,283.87	\$42,291,281.64	\$15,448,326.39	85.15 %

Stillwater Public Schools

Budget Analysis

Options: Year: 2025-2026, Date Range: 7/1/2025 - 3/31/2026, Print Detail: False

Classification	Appropriation	Encumbered	Paid	Encumbered Balance	Unencumbered Balance	% Enc Budget
Report Total	\$104,021,891.90	\$88,573,565.51	\$46,282,283.87	\$42,291,281.64	\$15,448,326.39	85.15 %

Report Request

Date Range: 7/1/2025 - 3/31/2026

Classification Bolding: N/A

Print Detail: No

Dimension	Group Order	Total	Bold	Filter
Fiscal Year	1	Yes	No	2026
Fund	2	Yes	No	11-41, 81
Project	3	Yes	No	
Function	N/A	N/A	N/A	
Object	N/A	N/A	N/A	
Program	N/A	N/A	N/A	
Subject	N/A	N/A	N/A	
JobClass	N/A	N/A	N/A	
Unit	N/A	N/A	N/A	

RESOLUTION AUTHORIZING SALE OF 2026A BONDS

PURSUANT TO NOTICE GIVEN UNDER THE OPEN MEETING ACT, THE BOARD OF EDUCATION OF INDEPENDENT SCHOOL DISTRICT NUMBER 16 OF PAYNE COUNTY, STATE OF OKLAHOMA (THE “SCHOOL DISTRICT”), MET IN REGULAR SESSION IN THE BOARD OF EDUCATION MEETING ROOM AT THE STILLWATER PUBLIC SCHOOLS ADMINISTRATION BUILDING, 314 S. LEWIS, STILLWATER, OKLAHOMA, 74074, ON THE 14TH DAY OF APRIL, 2026, AT 5:30 O’CLOCK P.M.

PRESENT:

ABSENT:

Notice of the schedule of regular meetings of the School District for the calendar year 2026 was given in writing to the County Clerk of Payne County, Oklahoma, at 10:23 o’clock a.m. on the 5th day of December, 2025, and public notice of this meeting, setting forth the date, time, place and agenda was posted at ___ o’clock __.m. on the ___ day of April, 2026, by posting on the School District’s Internet website (www.stillwaterschools.com) the date, time, place and agenda for the meeting in accordance with Title 25, Oklahoma Statutes, Section 311.1, being twenty-four (24) hours or more prior to this meeting, excluding Saturdays, Sundays and State designated legal holidays, all in compliance with the Oklahoma Open Meeting Act (as attached hereto). Further, as required by Title 25 Oklahoma Statutes § 311A(9)(a)(1), the School District made the notice of a public meeting available to the public in the principal office of the public body (314 S. Lewis, Stillwater, Oklahoma, 74074) during normal business hours at least twenty-four (24) hours prior to the meeting.

(OTHER PROCEEDINGS)

Thereupon, the President introduced a Resolution, which was read by title by the Clerk and upon motion by _____, seconded by _____, said the following vote adopted Resolution:

AYE:

NAY: None

Said Resolution was thereupon signed by the President or Vice President, attested by the Clerk or Deputy Clerk, sealed with the seal of said School District and is as follows:

RESOLUTION

A RESOLUTION FIXING THE AMOUNT OF COMBINED PURPOSE GENERAL OBLIGATION BONDS, SERIES 2026A TO MATURE EACH YEAR; FIXING THE TIME AND PLACE THE BONDS ARE TO BE SOLD; DESIGNATING A REGISTRAR/PAYING AGENT AND DISCLOSURE COUNSEL; APPROVING THE PRELIMINARY OFFICIAL STATEMENT AND DISTRIBUTION THEREOF; RATIFYING AND CONFIRMING CONTINUING DISCLOSURE POLICIES AND PROCEDURES; AUTHORIZING THE CLERK TO GIVE NOTICE OF SAID SALE AS REQUIRED BY LAW AND APPROVING OTHER MATTERS RELATED TO THE ISSUANCE OF SAID BONDS.

WHEREAS, on the 14th day of February, 2023, pursuant to notice duly given, an election was held in Independent School District Number 16 of Payne County, Oklahoma, for the purpose of submitting to the registered qualified electors of such School District as Proposition No. 1, the question of the issuance of the bonds for said School District in the sum of \$190,000,000 to provide funds for the purpose of acquiring, constructing, equipping, repairing and remodeling school buildings, acquiring school furniture, fixtures and equipment and acquiring and improving school sites; or in the alternative to acquire all or a distinct portion of such property pursuant to a lease purchase arrangement (the “Building and Equipment Bonds”); and

WHEREAS, as shown by the Official Certificate of Votes by the County Election Board of Payne County, Oklahoma, at said election there were cast on Proposition No. 1 by the registered, qualified electors of said School District 4,389 votes, which 3,428 were in favor of and 961 were against the issuance of said Building and Equipment Bonds; and

WHEREAS, a lawful majority of the registered, qualified voters voting on Proposition No. 1 cast their ballots in favor of the issuance of said Building and Equipment Bonds, as certified by the Payne County Election Board, and the issuance thereof has been duly authorized; and

WHEREAS, on the 14th day of February, 2023, pursuant to notice duly given, an election was held in Independent School District Number 16 of Payne County, Oklahoma, for the purpose of submitting to the registered qualified electors of such District as Proposition No. 2, the question of the issuance of the bonds for said School District in the sum of \$5,000,000 to provide funds for the purpose of acquiring transportation equipment; or in the alternative to acquire all or a distinct portion of such property pursuant to a lease purchase arrangement (the “Transportation Equipment Bonds”); and

WHEREAS, as shown by the Official Certificate of Votes by the County Election Board of Payne County, Oklahoma, at said election there were cast on Proposition No. 2 by the registered, qualified electors of said School District 4,371 votes, which 3,520 were in favor of and 851 were against the issuance of said Transportation Equipment Bonds; and

WHEREAS, a lawful majority of the registered, qualified voters voting on Proposition No. 2 cast their ballots in favor of the issuance of said Transportation Equipment Bonds, as certified by the Payne County Election Board, and the issuance thereof has been duly authorized; and

WHEREAS, the Board of Education of the School District previously issued \$12,000,000 of Building and Equipment Bonds as part of its \$12,000,000 General Obligation Building Bonds, Series 2023 dated June 1, 2023; and

WHEREAS, the Board of Education of the School District previously issued \$12,520,000 of Building and Equipment Bonds and \$480,000 of Transportation Equipment Bonds as part of its \$13,000,000 Combined Purpose General Obligation Bonds, Series 2024 dated June 1, 2024; and

WHEREAS, the Board of Education of the School District previously issued \$15,265,000 of Building and Equipment Bonds and \$485,000 of Transportation Equipment Bonds as part of its \$15,750,000 Combined Purpose General Obligation Bonds, Series 2025A dated June 1, 2025; and

WHEREAS, there is currently authorized, yet unissued, \$150,215,000 of Building and Equipment Bonds (Proposition No. 1); and

WHEREAS, there is currently authorized, yet unissued, \$4,035,000 of Transportation Equipment Bonds (Proposition No. 2); and

WHEREAS, it is deemed advisable by the Board of Education of said School District at this time to issue an aggregate principal amount of \$17,960,000 of Building and Equipment Bonds (Proposition No. 1) to finance a portion of the Building and Equipment Bond projects; and

WHEREAS, it is deemed advisable by the Board of Education of said School District at this time to issue an aggregate principal amount of \$490,000 of Transportation Equipment Bonds (Proposition No. 2) to finance a portion of the Transportation Equipment Bond projects; and

WHEREAS, it is deemed advisable by the Board of Education of said School District to issue all of said bonds as a combined issue of bonds as authorized by Title 62, Oklahoma Statutes 2021, Sections 353 and 354, as amended.

NOW, THEREFORE, BE IT RESOLVED BY THE BOARD OF EDUCATION OF INDEPENDENT SCHOOL DISTRICT NUMBER 16 OF PAYNE COUNTY, OKLAHOMA:

SECTION 1. That the \$17,960,000 Building and Equipment Bonds and \$490,000 of Transportation Equipment Bonds of Independent School District Number 16 of Payne County, Oklahoma, are hereby combined and offered for purposes of sale as authorized by Title 62, Oklahoma Statutes 2021, Sections 353 and 354, and shall be sold at public sale in the amount of \$18,450,000 and shall be called “Combined Purpose General Obligation Bonds, Series 2026A”.

SECTION 2. That the bids for said Combined Purpose General Obligation Bonds, Series 2026A of Independent School District Number 16 of Payne County, Oklahoma, in the amount of \$18,450,000 (referred to herein as the “2026A Bonds”), voted on the 14th day of February, 2023, shall be offered for sale and bids shall be received in the form of sealed bid, electronic (Parity®) bid or similar secure electronic bid in the Stillwater Public Schools Administration Building, 314 South Lewis, Stillwater, Oklahoma, 74074, on the 12th day of May, 2026 at 11:00 o’clock A.M., Central Time, and that said 2026A Bonds shall become due as follows:

Combined Purpose General Obligation Bonds, Series 2026A

<u>Due Date</u>	<u>Amount</u>
6/1/2028	\$3,075,000
6/1/2029	\$3,075,000
6/1/2030	\$3,075,000
6/1/2031	\$3,075,000
6/1/2032	\$3,075,000
6/1/2033	\$3,075,000

The Board of Education of the School District intends to convene on said date to consider the bids and take action to award the 2026A Bonds; the Board of Education is presently scheduled to convene at 5:30 o'clock, P.M. on May 12, 2026, in the Board of Education Meeting Room at the Stillwater Public Schools Administration Building, 314 South Lewis, Stillwater, Oklahoma, 74074, provided, however, the Board of Education reserves the right to change the location or time of the meeting in a manner consistent with the Oklahoma Open Meetings Act, and provided further, the Board of Education reserves the right to convene said meeting as a video and/or teleconference, as permitted under the Oklahoma Open Meetings Act. The Board of Education of the School District hereby confirms and stipulates that bids for the 2026A Bonds shall be made by sealed or electronic bids, that the 2026A Bonds shall be sold to the bidder bidding the lowest interest cost, to be determined based on true interest cost as calculated from June 1, 2026, and that each bidder on the 2026A Bonds shall submit with its bid a sum in cash, cashier's check, surety bond or similar security undertaking as stipulated by the School District, payable to the Treasurer of the School District, equal to two (2%) percent of the par value of the 2026A Bonds.

SECTION 3. That BOKF, NA, Tulsa, Oklahoma is hereby designated as Registrar/Paying Agent for said 2026A Bonds and the President of the Board of Education is authorized to execute an agreement for such services. That Kutak Rock LLP is hereby designated as Disclosure Counsel for said Bonds and the President or Vice President is authorized to execute an agreement for such services.

SECTION 4. The form of Preliminary Official Statement outlining the terms, conditions and security for the 2026A Bonds is hereby adopted and approved, and the President or Vice President is authorized to approve any corrections, additions or deletions thereto for and on behalf of the School District. Thereupon, the President or Vice President is authorized and directed to execute and deliver the Preliminary Official Statement for and on behalf of the School District, and further, the President or Vice President is authorized and directed to execute and deliver for and on behalf of the School District a certificate deeming the Preliminary Official Statement to be "final" in accordance with the requirements of Rule 15c2-12 of the Securities and Exchange Commission promulgated pursuant to the Securities and Exchange Act of 1934. Distribution of the Preliminary Official Statement by the Financial Advisor in connection with the sale of the 2026A Bonds is hereby expressly authorized; and further, the President or Vice President is authorized and directed to approve, execute and deliver a Final Official Statement or Official Statement for and on behalf of the School District upon issuance of the 2026A Bonds.

SECTION 5. The School District hereby ratifies and confirms the Continuing Disclosure Policies and Procedures for and on behalf of the School District (as defined in said Policies and Procedures), with respect to Obligations (as defined in said Policies and Procedures) that may be subject to continuing disclosure requirements pursuant to SEC Rule 15c2-12.

SECTION 6. That the Clerk of the Board of Education is hereby ordered and directed to cause notice of the sale of said 2026A Bonds to be given as required by law.

SECTION 7. The President, Vice President, Superintendent, Treasurer, Chief Financial Officer, Board Clerk or Deputy Clerk are hereby authorized and directed to execute, separately or jointly, and deliver such documents and take such other action as may be necessary or appropriate in order to effectuate the issuance, execution and delivery of the 2026A Bonds, including specifically, but not limited to, the Bond forms, tax or tax compliance documents, closing certificates, continuing disclosure or other security or securities related documents or any other letter, representation or certification otherwise necessary and attendant to the issuance and delivery of the 2026A Bonds.

[Remainder of Page Left Blank Intentionally]

Adopted this 14th day of April, 2026.

(SEAL)

President, Board of Education

ATTEST:

Clerk, Board of Education

STATE OF OKLAHOMA)
)
COUNTY OF PAYNE)

I, the undersigned, the duly qualified and acting Clerk of the Board of Education of Independent School District Number 16 of Payne County, Oklahoma, hereby certify that the foregoing is a true and complete copy of a Resolution authorizing the sale of bonds for the purpose therein set out, adopted by said Board and transcript of proceedings of said Board at a special meeting thereof duly held on the date therein set out, insofar as the same relates to the introduction, reading and adoption thereof as the same appears of record in my office.

I further certify that attached hereto is a true and complete copy of the Notice of the schedule of regular meetings of the governing body of Independent School District Number 16 of Payne County, Oklahoma, for calendar year 2026 having been given in writing to the County Clerk of Payne County, Oklahoma at 10:23 o'clock a.m. on the 5th day of December, 2025, and public notice of this meeting, setting forth the date, time, place and agenda was posted at ___ o'clock __.m. on the ___ day of April, 2026, by posting on the School District's Internet website (www.stillwaterschools.com) the date, time, place and agenda for the meeting in accordance with Title 25, Oklahoma Statutes, Section 311.1, being twenty-four (24) hours or more prior to this meeting, excluding Saturdays, Sundays and State designated legal holidays, all in compliance with the Oklahoma Open Meeting Act (as attached hereto). Further, as required by Title 25 Oklahoma Statutes § 311A(9)(a)(1), the School District made the notice of a public meeting available to the public in the principal office of the public body (314 S. Lewis, Stillwater, Oklahoma, 74074) during normal business hours at least twenty-four (24) hours prior to the meeting.

WITNESS my hand and official seal this 14th day of April, 2026.

(SEAL)

Clerk, Board of Education

NOTICE OF SALE OF 2026A BONDS

In accordance with Title 62, Oklahoma Statutes 2021, Sections 353 and 354, as amended, notice is hereby given that the Board of Education of Independent School District Number 16 of Payne County, Oklahoma (the "School District"), will receive bids by sealed bid, electronic (Parity®) bid or similar secure electronic bid on the 12th day of May, 2026, at 11:00 o'clock A.M., Central Time, at the Stillwater Public Schools Administration Building, 314 South Lewis, Stillwater, Oklahoma, 74074 (the "Board of Education Meeting Room") for the sale of \$18,450,000 Combined Purpose General Obligation Bonds, Series 2026A dated June 1, 2026, of said School District, of which \$3,075,000 of such Bonds will mature on June 1, 2028, and shall mature \$3,075,000 annually each year thereafter until paid. The Board of Education of the School District intends to convene on said date to consider the bids and take action to award the Bonds; the Board of Education is presently scheduled to convene at 5:30 o'clock, P.M. on May 12, 2026, in the Board of Education Meeting Room at the Stillwater Public Schools Administration Building, 314 South Lewis, Stillwater, Oklahoma, 74074, provided, however, the Board of Education reserves the right to change the location or time of the meeting in a manner consistent with the Oklahoma Open Meetings Act, and provided further, the Board of Education reserves the right to convene said meeting as a video and/or teleconference, as permitted under the Oklahoma Open Meetings Act.

Said Bonds shall be sold to the bidder bidding the lowest true interest cost the Bonds shall bear and agreeing to pay par and accrued interest for the Bonds. Each bidder shall submit with the bid a sum in cash, cashier's check, surety bond or similar security undertaking as stipulated by the School District, payable to the Treasurer of the School District, equal to two (2%) percent of the par value of the Bonds, or \$369,000.00. If a financial surety bond is used, it must be from an insurance company licensed to issue such bond in the State of Oklahoma, and such bond must be submitted to the School District or the School District's Financial Advisor prior to the opening of the bids. The financial surety bond must identify each bidder whose deposit is guaranteed by such financial surety bond. All bids must comply with the parameters set forth in the Notice of Sale and Instructions to Bidders, a copy of which may be obtained by contacting the School District's Financial Advisor (Municipal Finance Services, Inc., c/o Jericah Dawson (405) 340-1727 or jericahdawson@mfsok.com). The Board reserves the right to reject all bids.

WITNESS my official hand and the seal of said School District this 14th day of April, 2026.

(SEAL)

Clerk, Board of Education

RESOLUTION AUTHORIZING SALE OF 2026B BONDS

PURSUANT TO NOTICE GIVEN UNDER THE OPEN MEETING ACT, THE BOARD OF EDUCATION OF INDEPENDENT SCHOOL DISTRICT NUMBER 16 OF PAYNE COUNTY, STATE OF OKLAHOMA (THE “SCHOOL DISTRICT”), MET IN REGULAR SESSION IN THE BOARD OF EDUCATION MEETING ROOM AT THE STILLWATER PUBLIC SCHOOLS ADMINISTRATION BUILDING, 314 S. LEWIS, STILLWATER, OKLAHOMA, 74074, ON THE 14TH DAY OF APRIL, 2026, AT 5:30 O’CLOCK P.M.

PRESENT:

ABSENT:

Notice of the schedule of regular meetings of the School District for the calendar year 2026 was given in writing to the County Clerk of Payne County, Oklahoma, at 10:23 o’clock a.m. on the 5th day of December, 2025, and public notice of this meeting, setting forth the date, time, place and agenda was posted at ___ o’clock __.m. on the ___ day of April, 2026, by posting on the School District’s Internet website (www.stillwaterschools.com) the date, time, place and agenda for the meeting in accordance with Title 25, Oklahoma Statutes, Section 311.1, being twenty-four (24) hours or more prior to this meeting, excluding Saturdays, Sundays and State designated legal holidays, all in compliance with the Oklahoma Open Meeting Act (as attached hereto). Further, as required by Title 25 Oklahoma Statutes § 311A(9)(a)(1), the School District made the notice of a public meeting available to the public in the principal office of the public body (314 S. Lewis, Stillwater, Oklahoma, 74074) during normal business hours at least twenty–four (24) hours prior to the meeting.

(OTHER PROCEEDINGS)

Thereupon, the President introduced a Resolution, which was read by title by the Clerk and upon motion by _____, seconded by _____, said the following vote adopted Resolution:

AYE:

NAY: None

Said Resolution was thereupon signed by the President or Vice President, attested by the Clerk or Deputy Clerk, sealed with the seal of said School District and is as follows:

RESOLUTION

A RESOLUTION FIXING THE AMOUNT OF GENERAL OBLIGATION BUILDING BONDS, TAXABLE SERIES 2026B TO MATURE EACH YEAR; FIXING THE TIME AND PLACE THE BONDS ARE TO BE SOLD; DESIGNATING A REGISTRAR/PAYING AGENT AND DISCLOSURE COUNSEL; APPROVING THE PRELIMINARY OFFICIAL STATEMENT AND DISTRIBUTION THEREOF; RATIFYING AND CONFIRMING CONTINUING DISCLOSURE POLICIES AND PROCEDURES; AUTHORIZING THE CLERK TO GIVE NOTICE OF SAID SALE AS REQUIRED BY LAW AND APPROVING OTHER MATTERS RELATED TO THE ISSUANCE OF SAID BONDS.

WHEREAS, on the 14th day of February, 2023, pursuant to notice duly given, an election was held in Independent School District Number 16 of Payne County, Oklahoma, for the purpose of submitting to the registered qualified electors of such School District as Proposition No. 1, the question of the issuance of the bonds for said School District in the sum of \$190,000,000 to provide funds for the purpose of acquiring, constructing, equipping, repairing and remodeling school buildings, acquiring school furniture, fixtures and equipment and acquiring and improving school sites; or in the alternative to acquire all or a distinct portion of such property pursuant to a lease purchase arrangement (the “Building and Equipment Bonds”); and

WHEREAS, as shown by the Official Certificate of Votes by the County Election Board of Payne County, Oklahoma, at said election there were cast on Proposition No. 1 by the registered, qualified electors of said School District 4,389 votes, which 3,428 were in favor of and 961 were against the issuance of said Building and Equipment Bonds; and

WHEREAS, a lawful majority of the registered, qualified voters voting on Proposition No. 1 cast their ballots in favor of the issuance of said Building and Equipment Bonds, as certified by the Payne County Election Board, and the issuance thereof has been duly authorized; and

WHEREAS, on the 14th day of February, 2023, pursuant to notice duly given, an election was held in Independent School District Number 16 of Payne County, Oklahoma, for the purpose of submitting to the registered qualified electors of such District as Proposition No. 2, the question of the issuance of the bonds for said School District in the sum of \$5,000,000 to provide funds for the purpose of acquiring transportation equipment; or in the alternative to acquire all or a distinct portion of such property pursuant to a lease purchase arrangement (the “Transportation Equipment Bonds”); and

WHEREAS, as shown by the Official Certificate of Votes by the County Election Board of Payne County, Oklahoma, at said election there were cast on Proposition No. 2 by the registered, qualified electors of said School District 4,371 votes, which 3,520 were in favor of and 851 were against the issuance of said Transportation Equipment Bonds; and

WHEREAS, a lawful majority of the registered, qualified voters voting on Proposition No. 2 cast their ballots in favor of the issuance of said Transportation Equipment Bonds, as certified by the Payne County Election Board, and the issuance thereof has been duly authorized; and

WHEREAS, the Board of Education of the School District previously issued \$12,000,000 of Building and Equipment Bonds as part of its \$12,000,000 General Obligation Building Bonds, Series 2023 dated June 1, 2023; and

WHEREAS, the Board of Education of the School District previously issued \$12,520,000 of Building and Equipment Bonds and \$480,000 of Transportation Equipment Bonds as part of its \$13,000,000 Combined Purpose General Obligation Bonds, Series 2024 dated June 1, 2024; and

WHEREAS, the Board of Education of the School District previously issued \$15,265,000 of Building and Equipment Bonds and \$485,000 of Transportation Equipment Bonds as part of its \$15,750,000 Combined Purpose General Obligation Bonds, Series 2025A dated June 1, 2025; and

WHEREAS, there is currently authorized, yet unissued, \$150,215,000 of Building and Equipment Bonds (Proposition No. 1); and

WHEREAS, there is currently authorized, yet unissued, \$4,035,000 of Transportation Equipment Bonds (Proposition No. 2); and

WHEREAS, it is deemed advisable by the Board of Education of said School District at this time to issue an aggregate principal amount of \$1,960,000 of Building and Equipment Bonds (Proposition No. 1) to finance a portion of the Building and Equipment Bond projects; and

WHEREAS, it is deemed advisable by the Board of Education of said School District to issue all of said bonds as a single issue of bonds as authorized by Title 62, Oklahoma Statutes 2021, Sections 353 and 354, as amended.

NOW, THEREFORE, BE IT RESOLVED BY THE BOARD OF EDUCATION OF INDEPENDENT SCHOOL DISTRICT NUMBER 16 OF PAYNE COUNTY, OKLAHOMA:

SECTION 1. That the \$1,960,000 Building and Equipment Bonds of Independent School District Number 16 of Payne County, Oklahoma, are hereby offered for purposes of sale as authorized by Title 62, Oklahoma Statutes 2021, Sections 353 and 354, and shall be sold at public sale in the amount of \$1,960,000 and shall be called “General Obligation Building Bonds, Taxable Series 2026B”.

SECTION 2. That the bids for said General Obligation Building Bonds, Taxable Series 2026B of Independent School District Number 16 of Payne County, Oklahoma, in the amount of \$1,960,000 (referred to herein as the “2026B Bonds”), voted on the 14th day of February, 2023, shall be offered for sale and bids shall be received in the form of sealed bid, electronic (Parity®) bid or similar secure electronic bid in the Stillwater Public Schools Administration Building, 314 South Lewis, Stillwater, Oklahoma, 74074, on the 12th day of May, 2026 at 11:30 o’clock A.M., Central Time, and that said 2026B Bonds shall become due as follows:

General Obligation Building Bonds, Taxable Series 2026B

<u>Due Date</u>	<u>Amount</u>
6/1/2028	\$1,960,000

The Board of Education of the School District intends to convene on said date to consider the bids and take action to award the 2026B Bonds; the Board of Education is presently scheduled to convene at 5:30 o'clock, P.M. on May 12, 2026, in the Board of Education Meeting Room at the Stillwater Public Schools Administration Building, 314 South Lewis, Stillwater, Oklahoma, 74074, provided, however, the Board of Education reserves the right to change the location or time of the meeting in a manner consistent with the Oklahoma Open Meetings Act, and provided further, the Board of Education reserves the right to convene said meeting as a video and/or teleconference, as permitted under the Oklahoma Open Meetings Act. The Board of Education of the School District hereby confirms and stipulates that bids for the 2026B Bonds shall be made by sealed or electronic bids, that the 2026B Bonds shall be sold to the bidder bidding the lowest interest cost, to be determined based on true interest cost as calculated from June 1, 2026, and that each bidder on the 2026B Bonds shall submit with its bid a sum in cash, cashier's check, surety bond or similar security undertaking as stipulated by the School District, payable to the Treasurer of the School District, equal to two (2%) percent of the par value of the 2026B Bonds.

SECTION 3. That BOKF, NA, Tulsa, Oklahoma is hereby designated as Registrar/Paying Agent for said 2026B Bonds and the President of the Board of Education is authorized to execute an agreement for such services. That Kutak Rock LLP is hereby designated as Disclosure Counsel for said Bonds and the President or Vice President is authorized to execute an agreement for such services.

SECTION 4. The form of Preliminary Official Statement outlining the terms, conditions and security for the 2026B Bonds is hereby adopted and approved, and the President or Vice President is authorized to approve any corrections, additions or deletions thereto for and on behalf of the School District. Thereupon, the President or Vice President is authorized and directed to execute and deliver the Preliminary Official Statement for and on behalf of the School District, and further, the President or Vice President is authorized and directed to execute and deliver for and on behalf of the School District a certificate deeming the Preliminary Official Statement to be "final" in accordance with the requirements of Rule 15c2-12 of the Securities and Exchange Commission promulgated pursuant to the Securities and Exchange Act of 1934. Distribution of the Preliminary Official Statement by the Financial Advisor in connection with the sale of the 2026B Bonds is hereby expressly authorized; and further, the President or Vice President is authorized and directed to approve, execute and deliver a Final Official Statement or Official Statement for and on behalf of the School District upon issuance of the 2026B Bonds.

SECTION 5. The School District hereby ratifies and confirms the Continuing Disclosure Policies and Procedures for and on behalf of the School District (as defined in said Policies and Procedures), with respect to Obligations (as defined in said Policies and Procedures) that may be subject to continuing disclosure requirements pursuant to SEC Rule 15c2-12.

SECTION 6. That the Clerk of the Board of Education is hereby ordered and directed to cause notice of the sale of said 2026B Bonds to be given as required by law.

SECTION 7. The President, Vice President, Superintendent, Treasurer, Chief Financial Officer, Board Clerk or Deputy Clerk are hereby authorized and directed to execute, separately or jointly, and deliver such documents and take such other action as may be necessary or appropriate in order to effectuate the issuance, execution and delivery of the 2026B Bonds, including

specifically, but not limited to, the Bond forms, tax or tax compliance documents, closing certificates, continuing disclosure or other security or securities related documents or any other letter, representation or certification otherwise necessary and attendant to the issuance and delivery of the 2026B Bonds.

[Remainder of Page Left Blank Intentionally]

Adopted this 14th day of April, 2026.

(SEAL)

President, Board of Education

ATTEST:

Clerk, Board of Education

STATE OF OKLAHOMA)
)
COUNTY OF PAYNE)

I, the undersigned, the duly qualified and acting Clerk of the Board of Education of Independent School District Number 16 of Payne County, Oklahoma, hereby certify that the foregoing is a true and complete copy of a Resolution authorizing the sale of bonds for the purpose therein set out, adopted by said Board and transcript of proceedings of said Board at a special meeting thereof duly held on the date therein set out, insofar as the same relates to the introduction, reading and adoption thereof as the same appears of record in my office.

I further certify that attached hereto is a true and complete copy of the Notice of the schedule of regular meetings of the governing body of Independent School District Number 16 of Payne County, Oklahoma, for calendar year 2026 having been given in writing to the County Clerk of Payne County, Oklahoma at 10:23 o'clock a.m. on the 5th day of December, 2025, and public notice of this meeting, setting forth the date, time, place and agenda was posted at ___ o'clock __.m. on the ___ day of April, 2026, by posting on the School District's Internet website (www.stillwaterschools.com) the date, time, place and agenda for the meeting in accordance with Title 25, Oklahoma Statutes, Section 311.1, being twenty-four (24) hours or more prior to this meeting, excluding Saturdays, Sundays and State designated legal holidays, all in compliance with the Oklahoma Open Meeting Act (as attached hereto). Further, as required by Title 25 Oklahoma Statutes § 311A(9)(a)(1), the School District made the notice of a public meeting available to the public in the principal office of the public body (314 S. Lewis, Stillwater, Oklahoma, 74074) during normal business hours at least twenty-four (24) hours prior to the meeting.

WITNESS my hand and official seal this 14th day of April, 2026.

(SEAL)

Clerk, Board of Education

NOTICE OF SALE OF 2026B BONDS

In accordance with Title 62, Oklahoma Statutes 2021, Sections 353 and 354, as amended, notice is hereby given that the Board of Education of Independent School District Number 16 of Payne County, Oklahoma (the "School District"), will receive bids by sealed bid, electronic (Parity®) bid or similar secure electronic bid on the 12th day of May, 2026, at 11:30 o'clock A.M., Central Time, at the Stillwater Public Schools Administration Building, 314 South Lewis, Stillwater, Oklahoma, 74074 (the "Board of Education Meeting Room") for the sale of \$1,960,000 General Obligation Building Bonds, Taxable Series 2026B dated June 1, 2026, of said School District, of which \$1,960,000 of such Bonds will mature on June 1, 2028. The Board of Education of the School District intends to convene on said date to consider the bids and take action to award the Bonds; the Board of Education is presently scheduled to convene at 5:30 o'clock, P.M. on May 12, 2026, in the Board of Education Meeting Room at the Stillwater Public Schools Administration Building, 314 South Lewis, Stillwater, Oklahoma, 74074, provided, however, the Board of Education reserves the right to change the location or time of the meeting in a manner consistent with the Oklahoma Open Meetings Act, and provided further, the Board of Education reserves the right to convene said meeting as a video and/or teleconference, as permitted under the Oklahoma Open Meetings Act.

Said Bonds shall be sold to the bidder bidding the lowest true interest cost the Bonds shall bear and agreeing to pay par and accrued interest for the Bonds. Each bidder shall submit with the bid a sum in cash, cashier's check, surety bond or similar security undertaking as stipulated by the School District, payable to the Treasurer of the School District, equal to two (2%) percent of the par value of the Bonds, or \$39,200.00. If a financial surety bond is used, it must be from an insurance company licensed to issue such bond in the State of Oklahoma, and such bond must be submitted to the School District or the School District's Financial Advisor prior to the opening of the bids. The financial surety bond must identify each bidder whose deposit is guaranteed by such financial surety bond. All bids must comply with the parameters set forth in the Notice of Sale and Instructions to Bidders, a copy of which may be obtained by contacting the School District's Financial Advisor (Municipal Finance Services, Inc., c/o Jericah Dawson (405) 340-1727 or jericahdawson@mfsok.com). The Board reserves the right to reject all bids.

WITNESS my official hand and the seal of said School District this 14th day of April, 2026.

(SEAL)

Clerk, Board of Education

PURSUANT TO NOTICE GIVEN UNDER THE OPEN MEETING ACT, THE BOARD OF EDUCATION OF INDEPENDENT SCHOOL DISTRICT NUMBER 16 OF PAYNE COUNTY, STATE OF OKLAHOMA (THE "SCHOOL DISTRICT"), MET IN REGULAR SESSION IN THE BOARD OF EDUCATION MEETING ROOM AT THE STILLWATER PUBLIC SCHOOLS ADMINISTRATION BUILDING, 314 S. LEWIS, STILLWATER, OKLAHOMA, 74074, ON THE 14TH DAY OF APRIL, 2026, AT 5:30 O'CLOCK P.M.

PRESENT:

ABSENT:

Notice of the schedule of regular meetings of the School District for the calendar year 2026 was given in writing to the County Clerk of Payne County, Oklahoma, at 10:23 o'clock a.m. on the 5th day of December, 2025, and public notice of this meeting, setting forth the date, time, place and agenda was posted at ___ o'clock __.m. on the ___ day of April, 2026, by posting on the School District's Internet website (www.stillwaterschools.com) the date, time, place and agenda for the meeting in accordance with Title 25, Oklahoma Statutes, Section 311.1, being twenty-four (24) hours or more prior to this meeting, excluding Saturdays, Sundays and State designated legal holidays, all in compliance with the Oklahoma Open Meeting Act (as attached hereto). Further, as required by Title 25 Oklahoma Statutes § 311A(9)(a)(1), the School District made the notice of a public meeting available to the public in the principal office of the public body (314 S. Lewis, Stillwater, Oklahoma, 74074) during normal business hours at least twenty-four (24) hours prior to the meeting.

(OTHER PROCEEDINGS)

Thereupon, the President introduced a Resolution, which was read by title by the Clerk and upon motion by _____, seconded by _____, said the following vote adopted Resolution:

AYE:

NAY: None

Said Resolution was thereupon signed by the President or Vice President, attested by the Clerk or Deputy Clerk, sealed with the seal of said School District and is as follows:

[Resolution Begins on Next Page]

A RESOLUTION APPROVING A SUBLEASE PURCHASE AGREEMENT PERTAINING TO THE ACQUISITION AND FINANCING OF IMPROVEMENTS TO SCHOOL BUILDINGS AND FACILITIES; APPROVING AN ESCROW AND PAYING AGENT AGREEMENT; APPROVING THE FORMS OF SUBLEASE PURCHASE AGREEMENT, GROUND LEASE AGREEMENT, TAX REGULATORY AGREEMENT, CONTINUING DISCLOSURE AGREEMENT, AND OFFICIAL STATEMENT; APPROVING OTHER DOCUMENTS AND CERTIFICATES RELATED THERETO; AND CONTAINING OTHER PROVISIONS RELATED THERETO.

WHEREAS, Independent School District No. 16 of Payne County, State of Oklahoma (the “School District”) desires to finance the costs of acquiring, constructing, equipping, repairing and remodeling school buildings, acquiring school furniture, fixtures and equipment and acquiring and improving school sites, along with related costs, all as approved by the voters of the School District at an election held February 14, 2023, and as outlined on Exhibit A and Exhibit G to the hereinafter referenced Sublease Purchase Agreement (collectively, the “Projects”); and

WHEREAS, the School District intends to enter into a Ground Lease Agreement (the “Ground Lease Agreement”) with the Payne County Economic Development Authority, an Oklahoma public trust with Payne County, Oklahoma, as its beneficiary, or such other duly authorized Oklahoma public trust as may be designated by the President of the School District (such public trust referred to herein as the “Authority”), for the purpose of conveying a leasehold interest in certain real property to the Authority upon which components of the Project may be constructed; and

WHEREAS, the Authority intends to issue its bonds and/or notes in one or more series in the aggregate original principal amount of not to exceed \$18,000,000 (collectively referred to herein as the “Bonds”) for the purpose of acquiring the hereinafter referenced Sublease Purchase Agreement, with said Bonds to be repaid from the Rental Payments described in the Sublease Purchase Agreement; and

WHEREAS, the School District intends to enter into a Sublease Purchase Agreement (the “Sublease Purchase Agreement”) with the Authority, whereby the Authority will cause to be constructed the Project, and will lease said Project to the School District for its use and benefit, with the repayment terms of said Sublease Purchase Agreement based upon the terms of a bond purchase agreement for purchase of the Bonds; and

WHEREAS, it is contemplated that there will be multiple Project components that will be bid separately and as said components are bid and said bids are accepted, supplemental schedule(s) with a detailed listing of said components will be executed by the parties to the Sublease Purchase Agreement and said supplemental schedule(s) will be attached as an exhibit to the Sublease Purchase Agreement; and

WHEREAS, funds received by the School District at closing of the Sublease Purchase Agreement will be deposited with BOKF, NA, Tulsa, Oklahoma, as escrow agent (the “Escrow Agent”), pursuant to an Escrow and Paying Agent Agreement (the “Escrow Agreement”), by and among the School District, the Authority, and the Escrow Agent; and

WHEREAS, General Obligation Bonds of the School District in the amount of not to exceed \$195,000,000 were authorized to be issued at an election held on February 14, 2023; and

WHEREAS, it is the intention of the School District to issue a portion of said General Obligation Bonds in several series beginning not later than August 31, 2027, and concluding not later than August 31, 2033, to pay the Acquisition Payments and applicable Rental Payments due on the Sublease Purchase Agreement at or prior to the Maximum Term of September 1, 2033, as more specifically set forth in the Sublease Purchase Agreement.

NOW, THEREFORE, BE IT RESOLVED BY THE BOARD OF EDUCATION OF INDEPENDENT SCHOOL DISTRICT NO. 16 OF PAYNE COUNTY, STATE OF OKLAHOMA:

Section 1. Sublease Purchase Agreement. The form of the Sublease Purchase Agreement between the Authority, as lessor, and the School District, as lessee, is hereby approved. Rental Payments in connection with said Sublease Purchase Agreement shall be payable annually on each September 1, beginning September 1, 2027, based upon an imputed interest rate of not to exceed 4.50% per annum. The original principal component of the Sublease Purchase Agreement shall not exceed \$18,000,000, the Maximum Term of the Sublease Purchase Agreement shall end not later than September 1, 2033, and Acquisition Payments shall be paid in several installments as set forth on Schedule A attached hereto, corresponding to the acquisition of Real Property and/or Equipment, all as more specifically set forth in the Sublease Purchase Agreement. Supplemental schedule(s) shall be attached from time to time as Exhibit A to the Sublease Purchase Agreement for the purpose of detailing the real property and/or equipment items purchased with proceeds of the Sublease Purchase Agreement, and said supplemental schedule(s) shall be executed by the President, or in the President's absence, the Vice-President, and shall not require further approval by the School District.

Section 2. Escrow Agreement. The form of the Escrow and Paying Agent Agreement by and among the School District, the Authority, and the Escrow Agent is hereby approved.

Section 3. Ground Lease Agreement. The form of the Ground Lease Agreement by and between the School District, as lessor, and the Authority, as lessee, is hereby approved.

Section 4. Tax Regulatory Agreement. The School District hereby approves the execution of a Tax Regulatory Agreement, which pertains to compliance with certain requirements of the Internal Revenue Code of 1986, as amended (the "Code"). The School District directs that the Chief Financial Officer, Treasurer, or other appropriate personnel of the School District shall be the individual assigned to monitor compliance with the provisions of the Tax Regulatory Agreement, for the purpose of ensuring that interest on the Bonds to be issued by the Authority shall be excluded for purposes of federal income taxation.

Section 5. Continuing Disclosure Agreement and Official Statement. To the extent required by the Authority in connection with the issuance of the Authority's Bonds, the President and Clerk (or in their absence or incapacity, the Vice-President and Deputy Clerk, respectively) are authorized to execute a Continuing Disclosure Agreement in an appropriate form, as a material inducement to the Purchaser(s) of the Bonds. The School District hereby covenants and agrees that

it will comply with and carry out all of the provisions of said Continuing Disclosure Agreement. Notwithstanding any other provision of this Resolution, failure of the School District to comply with the Continuing Disclosure Agreement shall not be considered an event of default on the Bonds; however, any Bondholder may take such actions as may be necessary and appropriate, including seeking mandate or specific performance by court order, to cause the School District to comply with its obligations under this Section. “Continuing Disclosure Agreement” shall mean that certain Continuing Disclosure Agreement executed by the School District and dated the date of issuance and delivery of the Bonds, as originally executed and as it may be amended from time to time in accordance with the terms thereof.

If required pursuant to the Continuing Disclosure Agreement, School District hereby covenants and agrees for the benefit of the Bondholders to provide annual financial information on the School District in accordance with the Continuing Disclosure Agreement and to provide, in a timely manner, notice of events specified in paragraph (b)(5)(i)(C) of Rule 15c2-12 promulgated by the Securities and Exchange Commission. The annual financial information and any notices of material events will be provided by the School District to the Municipal Securities Rulemaking Board via the Electronic Municipal Market Access System (“EMMA”) @ www.emma.msrb.org.

The School District authorizes the use of an Official Statement or other offering materials in connection with the sale of the Bonds by the Purchaser(s) thereof.

Section 6. Execution and Approval of Necessary Documents. The President and Clerk (or in their absence or incapacity, the Vice-President and Deputy Clerk, respectively), are hereby authorized and directed on behalf of the School District to approve and execute all necessary legal documents, rating requests, tax certificates and closing papers required by legal counsel; to approve any changes to the documents approved hereby; and to execute, record and file any and all the necessary financing statements, security instruments, including but not limited to the documents approved hereby and to consummate the transaction contemplated hereby, the execution and delivery of all such documents by the President and Clerk (or in their absence or incapacity, the Vice-President and Deputy Clerk, respectively), being conclusive as to the approval by the School District thereof.

[Remainder of Page Left Blank Intentionally]

PASSED AND APPROVED THIS 14TH DAY OF APRIL, 2026.

(SEAL)

ATTEST:

President, Board of Education

Clerk, Board of Education

STATE OF OKLAHOMA)
)
COUNTY OF PAYNE)

I, the undersigned, the duly qualified and acting Clerk of the Board of Education of Independent School District Number 16 of Payne County, Oklahoma, hereby certify that the foregoing is a true and complete copy of a Resolution adopted by said Board and transcript of proceedings of said Board at a regular meeting thereof held on the date therein set out, insofar as the same relates to the introduction, reading and adoption thereof as the same appears of record in my office.

I further certify that attached hereto is a true and complete copy of the Notice of the schedule of regular meetings of the governing body of Independent School District Number 16 of Payne County, Oklahoma, for calendar year 2026 having been given in writing to the County Clerk of Payne County, Oklahoma at 10:23 o'clock a.m. on the 5th day of December, 2025, and public notice of this meeting, setting forth the date, time, place and agenda was posted at ___ o'clock __.m. on the ___ day of April, 2026, by posting on the School District's Internet website (www.stillwaterschools.com) the date, time, place and agenda for the meeting in accordance with Title 25, Oklahoma Statutes, Section 311.1, being twenty-four (24) hours or more prior to this meeting, excluding Saturdays, Sundays and State designated legal holidays, all in compliance with the Oklahoma Open Meeting Act (as attached hereto). Further, as required by Title 25 Oklahoma Statutes § 311A(9)(a)(1), the School District made the notice of a public meeting available to the public in the principal office of the public body (314 S. Lewis, Stillwater, Oklahoma, 74074) during normal business hours at least twenty-four (24) hours prior to the meeting.

WITNESS my hand and official seal this 14th day of April, 2026.

(SEAL)

Clerk, Board of Education



STILLWATER PUBLIC SCHOOLS
STILLWATER BOARD OF EDUCATION

PREPARED BY: Bo Gamble, Assistant Superintendent of Operations
APPROVED BY: Tyler Bridges, Superintendent
DATE: April 14, 2026

AGENDA ITEM:

Consider and Vote to Award Bids for the Stillwater Public Schools 2023 Stillwater High School, Athletics Phase I Civil and Landscape Bid Package to the following Bidders:

<u>Description</u>	<u>Actual Bid</u>	<u>Bidder</u>
Earthwork	\$496,750.00	MK Excavation, LLC
Site Utilities	\$571,000.00	Patriot Construction Services Inc.
Paving & Walks and Concrete Retaining Wall	\$565,000.00	Timber Wolf Excavating, LLC
Landscape & Irrigation	\$284,713.97	AAA Landscaping Inc.
Fencing	\$58,800.00	A Better Fence Construction & Landscaping
Athletic Fields	\$1,231,500.00	United Turf & Track
Flagpoles	\$5,070.00	Factory Direct Flagpoles & Accessories
Miscellaneous Metals	\$69,216.00	Clint's Welding, LLC

BOARD ACTION REQUESTED:

Vote to Award Bids for the Stillwater Public Schools 2023 Stillwater High School, Athletics Phase I Civil and Landscape Bid Package as presented

BACKGROUND INFORMATION:

Bids for Stillwater Public Schools Bond 2023 High School Athletics Phase I Civil and Landscape Bid Package were opened on March 26, 2026 at 2:00 p.m. The construction manager (Willowbrook Inc.) has examined all low bids, verified accuracy, and the bidders' ability to perform. They are now requesting approval of the lowest and best bids as listed above.

Stillwater High School
Athletics Civil Landscape Package

Bid Recommendation (Base Bid + Alternate 1)

Sealed Bids were opened and read aloud in accordance with the Advertisement for Bids at 2:00 PM on March 26, 2026 for the following:

Subcontractor	Base Bid	Alt 1: Extended Warranty Turf	Total
02 - Earthwork			
MK Excavation, LLC	\$ 496,750.00		\$ 496,750.00
Circle SM Contracting LLC	\$ 817,682.00		\$ 817,682.00
Timber Wolf Excavating, LLC	\$ 948,480.00		\$ 948,480.00
Great Plains Construction, LLC	\$ 1,186,100.00		\$ 1,186,100.00

RECOMMENDATION: Award the Base Bid to the low responsible bidder, MK Excavation, LLC, for a total of \$496,750.00.

03 - Site Utilities			
Patriot Construction Services Inc	\$ 571,000.00		\$ 571,000.00
Grooms & Pollard Utility Services	\$ 576,790.00		\$ 576,790.00
Civil Builders, LLC	\$ 634,750.00		\$ 634,750.00
D. Owen Construction	\$ 670,000.00		\$ 670,000.00
MK Excavation, LLC	\$ 698,600.00		\$ 698,600.00
Timber Wolf Excavating, LLC	\$ 860,500.00		\$ 860,500.00

RECOMMENDATION: Award the Base Bid to the low responsible bidder, Patriot Construction Services, Inc., for a total of \$571,000.00.

04 - Paving & Walks			
Timber Wolf Excavating, LLC (Combo 4 & 10)	\$ 565,000.00		\$ 565,000.00
4G Concrete, Inc.	\$ 294,700.00		\$ 294,700.00
Tuff Construction Services LLC	\$ 398,870.00		\$ 398,870.00
Lopp Construction	\$ 485,375.00		\$ 485,375.00

RECOMMENDATION: The combination bid submitted for BP 4 Paving & Walks and BP 10 Concrete Retaining Walls is lower than the individual bids. Therefore, we recommend awarding the Combination Base Bid to the low responsible bidder, Timber Wolf Excavating, LLC, for a total contract amount of \$565,000.00.

05 - Landscape & Irrigation			
AAA Landscaping Inc	\$ 284,713.97		\$ 284,713.97
Thrive Landscape & Irrigation	\$ 306,500.00		\$ 306,500.00
Galt Landscape	\$ 330,922.73		\$ 330,922.73
Greenshade Trees LLC	\$ 350,000.00		\$ 350,000.00
Grooms Irrigation Company	\$ 372,000.00		\$ 372,000.00
Garden Depot	\$ 433,000.00		\$ 433,000.00

RECOMMENDATION: Award the Base Bid to the low responsible bidder, AAA Landscaping, Inc., for a total of \$284,713.97.

Stillwater High School
Athletics Civil Landscape Package

Subcontractor	Base Bid	Alt 1: Extended Warranty Turf	Total
06 - Fencing			
A Better Fence Construction & Landscaping	\$ 58,800.00		\$ 58,800.00
Liberty Fence & Supply, LLC	\$ 63,062.36		\$ 63,062.36
American Fence Company, Inc.	\$ 69,094.72		\$ 69,094.72
Apex Fence & Construction LLC	\$ 79,750.00		\$ 79,750.00
Superior Fence Construction, Inc.	\$ 95,985.00		\$ 95,985.00
RECOMMENDATION: Award the Base Bid to the low responsible bidder, A Better Fence Construction and Landscaping, for a total of \$58,800.			
07 - Athletic Fields			
United Turf & Track	\$ 1,200,000.00	\$ 31,500.00	\$ 1,231,500.00
Greenshade Trees LLC	\$ 1,310,000.00	\$ 55,000.00	\$ 1,365,000.00
RECOMMENDATION: Award the Base Bid plus Alternate No 1 to the low responsible bidder, United Turf & Track, for a total of \$1,231,500.00.			
08 - Flagpoles			
Factory Direct Flagpoles & Accessories	\$ 5,070.00		\$ 5,070.00
Flag & Flagpole Express LLC	\$ 6,370.00		\$ 6,370.00
Specialty Sales Associates	\$ 7,328.00		\$ 7,328.00
Pole-Tech Company Inc	\$ 2,440.00		\$ 2,440.00
Eder Flag	\$ 2,745.00		\$ 2,745.00
RECOMMENDATION: The first and second low bidders did not provide a complete scope of work, therefore considered non-responsive. Recommend to award the Base Bid to the low responsible bidder, Factory Direct Flagpoles & Accessories, for a total of \$5,070.			
09 - Misc. Metals			
Clint's Welding LLC	\$ 69,216.00		\$ 69,216.00
Apex Fence & Construction LLC	\$ 90,300.00		\$ 90,300.00
Shawnee Fabricators Inc	\$ 111,766.00		\$ 111,766.00
RECOMMENDATION: Award the Base Bid to the low responsible bidder, Clint's Welding, LLC, for a total of \$69,216.00.			
10 - Concrete Retaining Wall			
Timber Wolf Excavating, LLC (Combo 4 & 10)	\$ 565,000.00		\$ 565,000.00
Lopp Construction, LLC	\$ 309,100.00		\$ 309,100.00
4G Concrete, Inc.	\$ 328,500.00		\$ 328,500.00
RECOMMENDATION: Award included as a combination bid in Bid Package #4 recommendation.			



STILLWATER PUBLIC SCHOOLS

STILLWATER BOARD OF EDUCATION

PREPARED BY: Bo Gamble, Assistant Superintendent of Operations
APPROVED BY: Tyler Bridges, Superintendent
DATE: April 14, 2026

AGENDA ITEM:

Consider and Vote to Accept Amendment 2 for the Guaranteed Maximum Price (GMP) Proposed by Willowbrook, Inc. for the Stillwater Public Schools Bond 2023 Stillwater High School, Athletics Phase I Civil and Landscape Package

BOARD ACTION REQUESTED:

Vote to Accept Amendment 2 for the Guaranteed Maximum Price (GMP) Proposed by Willowbrook, Inc. for the Stillwater Public Schools Bond 2023 Stillwater High School, Athletics Phase I Civil and Landscape Package

BACKGROUND INFORMATION:

Amendment 2 for the Guaranteed Maximum Price (GMP) includes the Civil and Landscape Construction costs for the Bond 2023 SPS High School Athletics Phase I Construction Project. The GMP consists of the pricing for trade categories, including allowances; the Construction Manager's contingency; alternates; the Construction Manager's fee; and other items that comprise the GMP.



AIA Document A133[®] – 2019 Exhibit A

Guaranteed Maximum Price Amendment

This Amendment dated the 14th day of April in the year 2026, is incorporated into the accompanying AIA Document A133[™]-2019, Standard Form of Agreement Between Owner and Construction Manager as Constructor where the basis of payment is the Cost of the Work Plus a Fee with a Guaranteed Maximum Price dated the 11th day of April in the year 2023. (the “Agreement”)

for the following PROJECT:

Amendment No. 2 (Base Bid + Alternate 1)

SPS Bond 2023
High School Athletics Phase 1
Civil and Landscape Package

THE OWNER:

Independent School District No. 16 of Payne County
314 S Lewis Street
Stillwater, OK 74074

THE CONSTRUCTION MANAGER:

Willowbrook, Inc.
Successor by name change to CMSWillowbrook, Inc.
620 NE 36th Street
Oklahoma City, OK 73105

TABLE OF ARTICLES

- A.1 GUARANTEED MAXIMUM PRICE
- A.2 DATE OF COMMENCEMENT AND SUBSTANTIAL COMPLETION
- A.3 INFORMATION UPON WHICH AMENDMENT IS BASED
- A.4 CONSTRUCTION MANAGER’S CONSULTANTS, CONTRACTORS, DESIGN PROFESSIONALS, AND SUPPLIERS

ARTICLE A.1 GUARANTEED MAXIMUM PRICE

§ A.1.1 Guaranteed Maximum Price

Pursuant to Section 3.2.6 of the Agreement, the Owner and Construction Manager hereby amend the Agreement to establish a Guaranteed Maximum Price. As agreed by the Owner and Construction Manager, the Guaranteed Maximum Price is an amount that the Contract Sum shall not exceed. The Contract Sum consists of the Construction Manager’s Fee plus the Cost of the Work, as that term is defined in Article 6 of the Agreement.

§ A.1.1.1 The Contract Sum is guaranteed by the Construction Manager not to exceed Four Million, Three Hundred Seventy-two Thousand, Seven Hundred Eighty-one Dollars and Ninety-seven cents (\$4,372,781.97), subject to additions and deductions by Change Order as provided in the Contract Documents.

ADDITIONS AND DELETIONS:

The author of this document may have revised the text of the original AIA standard form. An *Additions and Deletions Report* that notes revisions to the standard form text is available from the author and should be reviewed. A vertical line in the left margin of this document indicates where the author has added to or deleted from the original AIA text.

This document has important legal consequences. Consultation with an attorney is encouraged with respect to its completion or modification.

AIA Document A201[™]-2017, General Conditions of the Contract for Construction, is adopted in this document by reference. Do not use with other general conditions unless this document is modified.

§ A.1.1.2 Itemized Statement of the Guaranteed Maximum Price. Provided below is an itemized statement of the Guaranteed Maximum Price organized by trade categories, including allowances; the Construction Manager's contingency; alternates; the Construction Manager's Fee; and other items that comprise the Guaranteed Maximum Price as defined in Section 3.2.1 of the Agreement.

See Exhibit A, Attachment No. 1 – Detail of Clarifications, Assumptions, Allowances

§ A.1.1.3 The Construction Manager's Fee is set forth in Section 6.1.2 of the Agreement.

§ A.1.1.4 The method of adjustment of the Construction Manager's Fee for changes in the Work is set forth in Section 6.1.3 of the Agreement.

§ A.1.1.5 Alternates

§ A.1.1.5.1 Alternates, if any, included in the Guaranteed Maximum Price:

Item	Price
Alternate #1: Extended Annual Maintenance Warranty of Synthetic Turf	\$ 35,675.00

§ A.1.1.5.2 Subject to the conditions noted below, the following alternates may be accepted by the Owner following execution of this Exhibit A. Upon acceptance, the Owner shall issue a Modification to the Agreement.

Item	Price	Conditions for Acceptance
N/A		

§ A.1.1.6 Unit prices, if any:

Item	Units and Limitations	Price per Unit (\$0.00)
N/A		

ARTICLE A.2 DATE OF COMMENCEMENT AND SUBSTANTIAL COMPLETION

§ A.2.1 The date of commencement of the Work shall be:

The date of execution of this Amendment.

Established as follows:

If a date of commencement of the Work is not selected, then the date of commencement shall be the date of execution of this Amendment.

§ A.2.2 Unless otherwise provided, the Contract Time is the period of time, including authorized adjustments, allotted in the Contract Documents for Substantial Completion of the Work. The Contract Time shall be measured from the date of commencement of the Work.

§ A.2.3 Substantial Completion

§ A.2.3.1 Subject to adjustments of the Contract Time as provided in the Contract Documents, the Construction Manager shall achieve Substantial Completion of the entire Work:

Not later than () calendar days from the date of commencement of the Work.

By the following date: September 2028

§ A.2.3.2 Subject to adjustments of the Contract Time as provided in the Contract Documents, if portions of the Work are to be completed prior to Substantial Completion of the entire Work, the Construction Manager shall achieve Substantial Completion of such portions by the following dates:

Portion of Work

Substantial Completion Date

§ A.2.3.3 If the Construction Manager fails to achieve Substantial Completion as provided in this Section A.2.3, liquidated damages, if any, shall be assessed as set forth in Section 6.1.6 of the Agreement.

ARTICLE A.3 INFORMATION UPON WHICH AMENDMENT IS BASED

§ A.3.1 The Guaranteed Maximum Price and Contract Time set forth in this Amendment are based on the Contract Documents and the following:

§ A.3.1.1 The following Supplementary and other Conditions of the Contract:

Document	Title	Date	Pages
Specification Book	Project Manual	February 20, 2026	All
Addendum	No. 1	March 6, 2026	All
Addendum	No. 2	March 20, 2026	All

§ A.3.1.2 The following Specifications:

See Attachment No. 2 – Index of Documents and Drawings

§ A.3.1.3 The following Drawings:

See Attachment No. 2 – Index of Documents and Drawings

§ A.3.1.4 The Sustainability Plan, if any:

Title	Date	Pages
-------	------	-------

Other identifying information:

§ A.3.1.5 Allowances, if any, included in the Guaranteed Maximum Price:

Item	Price
Unforeseen Conditions	\$75,000.00
Patch/Repair Paving	\$15,000.00
Athletic Equipment	\$175,000.00
Pom/Cheer/Soccer/Track	\$1,000.00

§ A.3.1.6 Assumptions and clarifications, if any, upon which the Guaranteed Maximum Price is based:

See Attachment No. 5 – Assumptions and Clarifications

§ A.3.1.7 The Guaranteed Maximum Price is based upon the following other documents and information:

See Attachment No. 3 – Recommendation of Bids

See Attachment No. 4 – Bid Qualifications

ARTICLE A.4 CONSTRUCTION MANAGER’S CONSULTANTS, CONTRACTORS, DESIGN PROFESSIONALS, AND SUPPLIERS

§ A.4.1 The Construction Manager shall retain the consultants, contractors, design professionals, and suppliers, identified below:

This Amendment to the Agreement entered into as of the day and year first written above.

OWNER *(Signature)*

(Printed name and title)



CONSTRUCTION MANAGER *(Signature)*

Weston DeHart, President

(Printed name and title)

BID PACKAGE	DESCRIPTION	BASE BID	Alternate 1: Extended Turf Warranty	TOTAL	CONTRACTOR	NOTES
	General Requirements	\$ -	\$ -	\$ -		
	General Conditions	\$ 312,902.00	\$ -	\$ 312,902.00		
1	Demolition (Previously Bid)	\$ -	\$ -	\$ -		
2	Earthwork	\$ 496,750.00	\$ -	\$ 496,750.00	MK Excavation, LLC	
3	Site Utilities	\$ 571,000.00	\$ -	\$ 571,000.00	Patriot Construction Services Inc.	
4	Paving & Walks	\$ 565,000.00	\$ -	\$ 565,000.00	Timber Wolf Excavating, LLC	
5	Landscape & Irrigation	\$ 284,713.97	\$ -	\$ 284,713.97	AAA Landscaping, Inc.	
6	Fencing	\$ 58,800.00	\$ -	\$ 58,800.00	A Better Fence Construction	
7	Athletic Fields	\$ 1,200,000.00	\$ 31,500.00	\$ 1,231,500.00	United Turf & Track	#2
8	Flagpoles	\$ 5,070.00	\$ -	\$ 5,070.00	Factory Direct Flagpoles & Accessories	
9	Misc. Metals	\$ 69,216.00	\$ -	\$ 69,216.00	Clint's Welding	
10	Concrete Retaining Wall	\$ -	\$ -	\$ -	INCLUDED W/ PAVING & WALKS	
	Allowance - Unforeseen Conditions	\$ 75,000.00	\$ -	\$ 75,000.00		#1
	Allowance - Patch/Repair Paving	\$ 15,000.00	\$ -	\$ 15,000.00		#1
	Allowance - Athletic Equipment	\$ 175,000.00	\$ -	\$ 175,000.00		#1
	Allowance- Building Permit- Pom/Cheer/Soccer/Track	\$ 1,000.00	\$ -	\$ 1,000.00		#1
					Bid Recommendations	#3
	Subtotal	\$ 3,829,451.97	\$ 31,500.00	\$ 3,860,951.97		
	Owner Contingency	\$ 191,473.00	\$ 1,575.00	\$ 193,048.00		
	CM Contingency	\$ 114,884.00	\$ 945.00	\$ 115,829.00		
	Bonds	\$ 25,582.00	\$ 210.00	\$ 25,792.00		
	Builders Risk Insurance	\$ 12,141.00	\$ 100.00	\$ 12,241.00		
	General Liability Insurance	\$ 16,910.00	\$ 139.00	\$ 17,049.00		
	Subtotal	\$ 4,190,441.97	\$ 34,469.00	\$ 4,224,910.97		
	CM Fee	\$ 146,665.00	\$ 1,206.00	\$ 147,871.00		
	TOTAL ESTIMATED CONSTRUCTION COST	\$ 4,337,106.97	\$ 35,675.00	\$ 4,372,781.97	<<< GMP	#4

Note #1: Final costs that are under/over this allowance will increase/decrease the CM's contingency amount. Any remaining portion of the CM's contingency will be returned to the Owner by a deduct change order at the end of the project.

Note #2: Bid Qualifications

Note #3: The bids have been solicited on the basis of award within 45 days.

Note #4: This GMP excludes A/E fee, civil engineering fee, CM pre-construction fee, FF&E, sales tax, 3rd party commissioning of mechanical or electrical systems, items provided by Owner, any requirements by the Authority Having Jurisdiction that are not specifically depicted or indicated on the Contract Documents, temporary & permanent utility cost during construction to start-up and occupying the building.

Stillwater Public Schools
Bond 2023 High School Athletics Phase 1

Exhibit "A"
SUMMARY OF FUNDS AS ISSUED TO WILLOWBROOK
(Includes all approved change orders)

	<u>DATE</u>	<u>AMOUNT</u>	<u>EXTENDED AMOUNT</u>
Pre-Construction Fee	2/10/2026	\$ -	\$ -
<u>Amendment No. 1 - SHS Athletics Demolition (Base Bid)</u>	2/10/2026		
GENERAL REQUIREMENTS		\$ 48,925.00	
GENERAL CONDITIONS		\$ 34,400.00	
Bid Package 1 - Demolition - Midwest Wrecking Co., LLC		\$ 834,840.00	
Allowance - Unforeseen Conditions		\$ 50,000.00	
Allowance - Utility Disconnects		\$ 15,000.00	
Allowance - Demo Baseball/Softball Building		\$ 22,110.00	
Owner Contingency		\$ 50,264.00	
CM Contingency		\$ 30,158.00	
Bonds		\$ 7,924.00	
Builders Risk Insurance		\$ 5,857.00	
General Liability Insurance		\$ 10,106.00	
CM Fee		\$ 38,835.00	
		\$ 1,148,419.00	\$ 1,148,419.00
Pre-Construction Fee	4/14/2026	\$ -	\$ -
<u>Amendment No. 2 - SHS Athletics Civil & Landscape (Base Bid + Alternate 1)</u>	4/14/2026		
GENERAL REQUIREMENTS		\$ -	
GENERAL CONDITIONS		\$ 312,902.00	
Bid Package 2 Earthwork - MK Excavation		\$ 498,750.00	
Bid Package 3 Site Utilities - Patriot Construction Services, Inc.		\$ 571,000.00	
Bid Package 4 Paving & Walks - Timber Wolf Excavating		\$ 565,000.00	
Bid Package 5 Landscape & Irrigations - AAA Landscaping		\$ 284,713.97	
Bid Package 6 Fencing - A Better Fence Construction		\$ 58,800.00	
Bid Package 7 Athletic Fields - United Turf & Track		\$ 1,231,500.00	
Bid Package 8 Flagpoles - Factory Direct Flagpoles & Accessories		\$ 5,070.00	
Bid Package 9 Misc. Metals - Clint's Welding		\$ 69,216.00	
Bid Package 10 Concrete Retaining Wall - Timber Wolf Excavating		\$ -	
Allowance - Unforeseen Conditions		\$ 75,000.00	
Allowance - Patch/Repair Paving		\$ 15,000.00	
Allowance - Athletic Equipmeny		\$ 175,000.00	
Allowance - Building Permit - Pom/Cheer/Soccer/Track		\$ 1,000.00	
Owner Contingency		\$ 193,048.00	
CM Contingency		\$ 115,829.00	
Bonds		\$ 25,792.00	
Builders Risk Insurance		\$ 12,241.00	
General Liability Insurance		\$ 17,049.00	
CM Fee		\$ 147,871.00	
		\$ 4,372,781.97	\$ 5,521,200.97

INDEX OF DOCUMENTS AND DRAWINGS

SPECIFICATIONS, dated February 20, 2026, consisting of:

Table of Contents (TOC)

Construction Manager TOC consisting of: Division 0 – Contract and Bidding Documents

Architectural TOC consisting of: Division 1, 3, 10, 11, 32

PLANS, dated February 20, 2026, consisting of:

SHEET INDEX

CIVIL

C100 COVER SHEET
C101 GENERAL CONSTRUCTION NOTES
C200 EROSION CONTROL PLAN
C201 EROSION CONTROL NOTES
C300 DIMENSION CONTROL AND SITE INDEX
C301 DIMENSION CONTROL AND SITE (1 OF 5)
C302 DIMENSION CONTROL AND SITE (2 OF 5)
C303 DIMENSION CONTROL AND SITE (3 OF 5)
C304 DIMENSION CONTROL AND SITE (4 OF 5)
C305 DIMENSION CONTROL AND SITE (5 OF 5)
C306 FIRE PROTECTION SITE PLAN
C400 DRAINAGE AREA MAP - EXISTING
C401 DRAINAGE AREA MAP - PROPOSED
C402 DRAINAGE SUBBASINS
C500 GRADING PLAN INDEX
C501 GRADING PLAN (1 OF 5)
C502 GRADING PLAN (2 OF 5)
C503 GRADING PLAN (3 OF 5)
C504 GRADING PLAN (4 OF 5)
C505 GRADING PLAN (5 OF 5)
C600 UTILITY PLAN INDEX
C601 UTILITY PLAN (1 OF 4)
C602 UTILITY PLAN (2 OF 4)
C603 UTILITY PLAN (3 OF 4)
C604 UTILITY PLAN (4 OF 4)
C700 PAVING PLAN INDEX
C701 PAVING PLAN (1 OF 5)
C702 PAVING PLAN (2 OF 5)
C703 PAVING PLAN (3 OF 5)
C704 PAVING PLAN (4 OF 5)
C705 PAVING PLAN (5 OF 5)
C800 MISCELLANEOUS CONSTRUCTION DETAILS (1 OF 3)
C801 MISCELLANEOUS CONSTRUCTION DETAILS (2 OF 3)
C802 MISCELLANEOUS CONSTRUCTION DETAILS (3 OF 3)

LANDSCAPE

L100 OVERALL SPECIALTY HARDSCAPE PLAN
L110 SPECIALTY HARDSCAPE PLAN ENLARGEMENTS
L111 SPECIALTY HARDSCAPE PLAN ENLARGEMENTS
L112 OVERALL CONCRETE JOINTING PLAN
L113 CONCRETE JOINTING PLAN ENLARGEMENTS

L114 CONCRETE JOINTING PLAN ENLARGEMENTS
L115 FENCE AND BARRIER PLAN
L120 MULTIPURPOSE PRACTICE FIELD PLAN
L130 SYNTHETIC TURF FIELD DETAILS
L131 FENCING DETAILS
L132 SPECIALTY HARDSCAPE DETAILS
L133 EXTERIOR SITE AMENITIES DETAILS
L134 PLAZA ELEVATIONS
L200 OVERALL LANDSCAPE PLAN
L210 LANDSCAPE PLAN ENLARGEMENTS
L211 LANDSCAPE PLAN ENLARGEMENTS
L212 OVERALL SOD PLAN
L220 LANDSCAPE DETAILS
L300 OVERALL PREFORMANCE IRRIGATION PLAN
L310 IRRIGATION PLAN ENLARGEMENTS
L311 IRRIGATION PLAN ENLARGEMENTS
L312 OVERALL QUICK COUPLER LAYOUT & WATER CONNECTION PLAN

ADDENDA

Addendum No 1, dated March 6, 2026

Sheets: COVER SHEET, C200, C201, C300, C302, C303, C305, C500, C501, C502, C503, C505, C601, C602, C603, C604, C700, C702, C703, C705, C800, L110, L111, L112, L113, L114, L115, L116, L131, L132, L133, L134, L210, L211, L212, L310, L311, AND L312

Addendum No 2, dated March 20, 2026

Sheets: L110, L116, L133

END OF SECTION

Stillwater High School
Athletics Civil Landscape Package

Bid Recommendation (Base Bid + Alternate 1)

Sealed Bids were opened and read aloud in accordance with the Advertisement for Bids at 2:00 PM on March 26, 2026 for the following:

Subcontractor	Base Bid	Alt 1: Extended Warranty Turf	Total
02 - Earthwork			
MK Excavation, LLC	\$ 496,750.00		\$ 496,750.00
Circle SM Contracting LLC	\$ 817,682.00		\$ 817,682.00
Timber Wolf Excavating, LLC	\$ 948,480.00		\$ 948,480.00
Great Plains Construction, LLC	\$ 1,186,100.00		\$ 1,186,100.00
RECOMMENDATION: Award the Base Bid to the low responsible bidder, MK Excavation, LLC, for a total of \$496,750.00.			
03 - Site Utilities			
Patriot Construction Services Inc	\$ 571,000.00		\$ 571,000.00
Grooms & Pollard Utility Services	\$ 576,790.00		\$ 576,790.00
Civil Builders, LLC	\$ 634,750.00		\$ 634,750.00
D. Owen Construction	\$ 670,000.00		\$ 670,000.00
MK Excavation, LLC	\$ 698,600.00		\$ 698,600.00
Timber Wolf Excavating, LLC	\$ 860,500.00		\$ 860,500.00
RECOMMENDATION: Award the Base Bid to the low responsible bidder, Patriot Construction Services, Inc., for a total of \$571,000.00.			
04 - Paving & Walks			
Timber Wolf Excavating, LLC (Combo 4 & 10)	\$ 565,000.00		\$ 565,000.00
4G Concrete, Inc.	\$ 294,700.00		\$ 294,700.00
Tuff Construction Services LLC	\$ 398,870.00		\$ 398,870.00
Lopp Construction	\$ 485,375.00		\$ 485,375.00
RECOMMENDATION: The combination bid submitted for BP 4 Paving & Walks and BP 10 Concrete Retaining Walls is lower than the individual bids. Therefore, we recommend awarding the Combination Base Bid to the low responsible bidder, Timber Wolf Excavating, LLC, for a total contract amount of \$565,000.00.			
05 - Landscape & Irrigation			
AAA Landscaping Inc	\$ 284,713.97		\$ 284,713.97
Thrive Landscape & Irrigation	\$ 306,500.00		\$ 306,500.00
Galt Landscape	\$ 330,922.73		\$ 330,922.73
Greenshade Trees LLC	\$ 350,000.00		\$ 350,000.00
Grooms Irrigation Company	\$ 372,000.00		\$ 372,000.00
Garden Depot	\$ 433,000.00		\$ 433,000.00
RECOMMENDATION: Award the Base Bid to the low responsible bidder, AAA Landscaping, Inc., for a total of \$284,713.97.			

Stillwater High School
Athletics Civil Landscape Package

Subcontractor	Base Bid	Alt 1: Extended Warranty Turf	Total
06 - Fencing			
A Better Fence Construction & Landscaping	\$ 58,800.00		\$ 58,800.00
Liberty Fence & Supply, LLC	\$ 63,062.36		\$ 63,062.36
American Fence Company, Inc.	\$ 69,094.72		\$ 69,094.72
Apex Fence & Construction LLC	\$ 79,750.00		\$ 79,750.00
Superior Fence Construction, Inc.	\$ 95,985.00		\$ 95,985.00
RECOMMENDATION: Award the Base Bid to the low responsible bidder, A Better Fence Construction and Landscaping, for a total of \$58,800.			
07 - Athletic Fields			
United Turf & Track	\$ 1,200,000.00	\$ 31,500.00	\$ 1,231,500.00
Greenshade Trees LLC	\$ 1,310,000.00	\$ 55,000.00	\$ 1,365,000.00
RECOMMENDATION: Award the Base Bid plus Alternate No 1 to the low responsible bidder, United Turf & Track, for a total of \$1,231,500.00.			
08 - Flagpoles			
Factory Direct Flagpoles & Accessories	\$ 5,070.00		\$ 5,070.00
Flag & Flagpole Express LLC	\$ 6,370.00		\$ 6,370.00
Specialty Sales Associates	\$ 7,328.00		\$ 7,328.00
Pole-Tech Company Inc	\$ 2,440.00		\$ 2,440.00
Eder Flag	\$ 2,745.00		\$ 2,745.00
RECOMMENDATION: The first and second low bidders did not provide a complete scope of work, therefore considered non-responsive. Recommend to award the Base Bid to the low responsible bidder, Factory Direct Flagpoles & Accessories, for a total of \$5,070.			
09 - Misc. Metals			
Clint's Welding LLC	\$ 69,216.00		\$ 69,216.00
Apex Fence & Construction LLC	\$ 90,300.00		\$ 90,300.00
Shawnee Fabricators Inc	\$ 111,766.00		\$ 111,766.00
RECOMMENDATION: Award the Base Bid to the low responsible bidder, Clint's Welding, LLC, for a total of \$69,216.00.			
10 - Concrete Retaining Wall			
Timber Wolf Excavating, LLC (Combo 4 & 10)	\$ 565,000.00		\$ 565,000.00
Lopp Construction, LLC	\$ 309,100.00		\$ 309,100.00
4G Concrete, Inc.	\$ 328,500.00		\$ 328,500.00
RECOMMENDATION: Award included as a combination bid in Bid Package #4 recommendation.			

Attachment No. 4 – Bid Qualifications

Bid Package 8 Flagpoles – Factory Direct Flagpoles & Accessories

Factory Direct Flagpoles

247 W Wilshire Blvd Ste B
 Oklahoma City, OK 73116
 +14054953524
 sales@shopflagpoles.com
 www.shopflagpoles.com

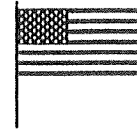

FACTORY DIRECT FLAGPOLES

Quote

ADDRESS	SHIP TO	ESTIMATE	11378
Willowbrook Construction	Stillwater High School	DATE	03/25/2026
620 NE 36th St.	1224 N. Husband St.		
Oklahoma City, OK 73105	Stillwater, OK 74075		

ITEM	DESCRIPTION	QUANTITY	UNIT PRICE	TOTAL PRICE
30x5x188 ECL30 Atlas Series Flagpole	30x5x188 *Gold anodized aluminum ball ornament *Cast aluminum revolving truck with pulley *Solid braided polyester halyard *Swivel flag snaps with vinyl covers *Cast aluminum cleat and mounting screws *Spun aluminum flash collar *Galvanized steel foundation sleeve *Wind rating with 5x8 flag - 100mph **CLEAR ANODIZED**	1	3,955.00	3,955.00T
Installation - 30' ER	Installation for a 30' External Rope Flagpole *** INSTALLATION THROUGH NATURAL DIRT ONLY *** *** WILLOWBROOK RESPONSIBLE FOR MARKING EXACT FLAGPOLE LOCATION & UTILITY LINES PRIOR TO INSTALLATION *** *** WILLOWBROOK TO COMMUNICATE WITH FDF 8 WEEKS PRIOR TO SCHEDULED FLAGPOLE INSTALLATION ***	1	1,115.00	1,115.00

SUBTOTAL	5,070.00
TAX	0.00
TOTAL	\$5,070.00

Listed are contractual requirements:

- 1) Prices are guaranteed for 30 days.
- 2) Flagpole orders must be paid in full upfront. Any exceptions must be agreed to by FDF before project begins.
- 3) Check or Cash is preferred. Credit Cards for invoices over \$1,000.00 will be assessed a 3% processing fee.
- 4) Quote is through Natural Dirt Only
- 5) 10% Restocking fee applies for all cancellations.

Attachment No. 5 – Assumptions and Clarifications

We have listed below the assumptions and clarifications that we have considered so that we both fully understand what is and what is not included in the Guaranteed Maximum Price (GMP). Where actual events on the project differ from the assumptions and clarifications listed below, the GMP will require adjustments for the resulting additional costs and expenses. These assumptions and clarifications are specifically used to establish the basis of the GMP and as such are intended to clarify and take precedence over details or items shown on Contract Documents, in the event there is a discrepancy between or among any of them.

Project: Stillwater High School Athletics Civil and Landscape Package

Date: April 14, 2026

Schedule

1. The work is scheduled to start May 2026 with completion in September 2028.
2. The bids have been solicited on the basis of award within 45 days.

Document Acknowledgement

3. This GMP is based on the Attachment No. 2 Index of Documents and Drawings included in this proposal.
4. This GMP is based on the 100% Final Bid Documents, dated February 20, 2026, prepared by 505 Architects.
5. This GMP is based on these Assumptions and Clarifications.

General

6. Stillwater District Standards scope, information, or direction not specifically incorporated into the Drawings, Specifications and/or Owner-CM Agreement are not included.
7. This GMP includes the cost for Willowbrook's General Conditions and Requirements. This time frame is based on the current project schedule. General Conditions and Requirements are lump sum.
8. Willowbrook will use Microsoft Project or P6 scheduling program for all project scheduling, and we assume that this program will satisfy all project schedule requirements.
9. Willowbrook will utilize the Construction Managers cloud-based management software for project administration including the processing of submittals, RFIs, emails, etc.
10. This GMP is based on the recommendation of bids entering and executing a contract.
11. This GMP is based on Design team will provide necessary CAD files to Willowbrook for various shop drawings and submittals at no additional costs.
12. Willowbrook has prepared this GMP based on current market conditions and escalations are not included.
13. This GMP is based on normal working hours. No premium time is included unless specifically noted otherwise.
14. Willowbrook shall not be liable nor have our right to proceed to be restricted for any failure to perform its obligations where such failure arises out of Acts of Nature including natural disasters, act of public enemies, hostilities (whether war is declared or not), civil war, rebellion, revolution, insurrection, military or usurped power of confiscation, riot, nationalization, government actions, tariffs, blockage, embargo, transportation delays not reasonably foreseeable, strike, lockout, disease outbreak, epidemics, pandemics, quarantine restrictions, or interruption of failure of power sources. To the extent these conditions may occur and impact the Project, there shall be an equitable adjustment to the Contract.
15. The following items are **NOT INCLUDED** in the GMP:
 - a. Design Fees for Architects and Consultants.

- b. Verification that the design indicated in the drawings and specifications meets code requirements.
 - c. Verification that the design indicated meets owner insurance and operational requirements.
 - d. PreConstruction Fee. This will be invoiced separately.
 - e. Abatement, mitigation and/or removal of hazardous or contaminated materials unless previously agreed upon.
 - f. Maintenance agreements beyond substantial completion, unless specifically stated within the contract documents.
 - g. Construction Testing and Inspection Services.
 - h. Temporary and permanent utility cost during construction.
 - i. Electric, Gas or Water municipal impact fees, as well as utility company charges for permanent power, telephone service and CATV.
 - j. Permanent utility cost during construction start-up, test and occupy the building.
 - k. Cost of permanent water and electrical power usage.
 - l. Furniture, Fixtures and Equipment unless previously agreed upon.
 - m. Sales Tax.
 - n. Items provided by Owner.
 - o. Owner and/or Design contingency.
 - p. Requirements by any Authority Having Jurisdiction that are not specifically depicted or indicated on the Contract Documents.
16. This GMP assumes that Owner furnished items will be on-site in accordance with the Construction Manager's schedule.
17. A Construction Manager's construction contingency is included in the GMP. This contingency is intended to cover the scope of work, including but not limited to events such as listed below. The construction contingency shall be the exclusive use of the Construction Manager.
- a. Unforeseen and/or unknown field conditions, as practical to keep schedule. Terms as stated in AIA-A201 – 3.7.4 Concealed or Unknown Conditions still apply.
 - b. Mitigation of weather impact, such as abnormal inclement weather.
 - c. Losses, expenses or damages not covered by insurance, including any deductible amount.
 - d. Subcontractor failures not covered by a subcontractor performance and payment bond.
 - e. Increases in quantity or quality, which should have been reasonably inferable from the Contract Documents but not specifically shown therein.
 - f. Items not properly coordinated or left out of the Bid Package scope of work.
 - g. Underestimating
 - h. Schedule acceleration and overtime including unexcused schedule delays due to subcontractor work, performance, or schedule.
 - i. Any unused construction contingency will be returned to the Owner by a deduct change order at the end of the project.
18. The order of precedence of the documents in the event that there is a conflict between documents is:
- a. Future change orders.
 - b. Assumptions and Clarifications
 - c. Agreement between Owner and Construction Manager.
 - d. Addenda as issued by the Architect.

- e. Contract drawings and specifications, as prepared by the Architect.

Tariff Fees and Import Duties

- 19. The parties acknowledge that fluctuation in tariff rates, import duties, or similar governmental imposed fees may impact the cost of materials and equipment used in this project. The Construction Manager shall use reasonable efforts to mitigate such costs, including sourcing alternate materials or suppliers but cannot guarantee avoiding future tariffs being imposed.
- 20. Any subsequent increases, new tariffs, or changes in trade regulations that result in additional costs shall be treated as follows:
 - a. If tariffs or import duties increase after the contract date, such increases shall be treated as an allowable adjustment to the GMP through a Change Order.
 - b. The Construction Manager shall promptly notify the Owner of any potential tariff-related cost impacts and shall provide supporting documentation for any requested adjustment.
- 21. If additional tariffs or duties result in increased costs, the Construction Manager shall submit a written request for a Change Order, detailing the specific materials affected, the original and adjusted cost due to tariffs, and reasonable efforts made to mitigate the increase.
- 22. The Owner shall review and, if justified, approve an adjustment to the GMP.

Insurance and Bonds

- 23. Builder's Risk Insurance is included for new construction only. Any renovation work shall be included on the Owner's existing property insurance policy.
- 24. We have not included any sales tax and will require a Sales Tax Exemption Certificate as a condition precedent to the issuance of any notices to proceed, subcontracts, purchase orders, etc.



STILLWATER PUBLIC SCHOOLS

STILLWATER BOARD OF EDUCATION

PREPARED BY: Bo Gamble, Assistant Superintendent of Operations
APPROVED BY: Tyler Bridges, Superintendent
DATE: April 14, 2026

AGENDA ITEM:

Consider and Vote to Assign Bids to Willowbrook, Inc. for the Stillwater Public Schools Bond 2023, Stillwater High School, Athletics Phase 1 Civil and Landscape Package

BOARD ACTION REQUESTED:

Vote to Assign Bids to Willowbrook, Inc. for the Stillwater Public Schools Bond 2023, Stillwater High School, Athletics Phase 1 Civil and Landscape Package

BACKGROUND INFORMATION:

Bids for Stillwater Public Schools Bond 2023, Stillwater High School, Athletics Phase 1 Civil and Landscape Package were opened on March 26, 2026, at 2:00 p.m. With approval, bids will be assigned to Willowbrook, Inc. for the securing of the low bid contractors to complete the Civil and Landscape package components of the project.



STILLWATER PUBLIC SCHOOLS
STILLWATER BOARD OF EDUCATION

PREPARED BY: Bo Gamble, Assistant Superintendent of Operations
APPROVED BY: Tyler Bridges, Superintendent
DATE: April 14, 2026

AGENDA ITEM:

Receive Bond 2023 Update.

BOARD ACTION REQUESTED:

This is an information item only. No board action is requested.

BACKGROUND INFORMATION:

Attached to this memo is an update on Bond 2023.

***SPS BOND 2023
PROJECTS REPORT
04.14.2026***



HS PHASE 1 AND 2 – CONSTRUCTION PHASE

- Owner, Architect, and Constructor (OAC) meetings are scheduled for every two weeks to review construction progress and coordination with upcoming installations of SPS Owner provided equipment and systems.
- Areas 1, 2 and 3 punches have been completed with 505 Architects and SPS.
- Areas 4, 5 and the exterior punches are scheduled the first week of May with 505 Architects and SPS.
- SPS FF&E Procurement is underway with orders placed for all the previous approved bids and with tentative delivery dates of the second week of May and the first week of June for HS Phase 1.

HS PHASE 1 AND 2 – CONSTRUCTION PHASE



MARCH 2, 2026



MARCH 25, 2026

HS PHASE 1 AND 2 - CONSTRUCTION PHASE



STILLWATER PUBLIC SCHOOLS



HS PHASE 1 AND 2 - CONSTRUCTION PHASE



STILLWATER PUBLIC SCHOOLS



HS PHASE 1 AND 2 – CONSTRUCTION PHASE

The following is a WORK SUMMARY of construction progress by Area:

SITE

Landscaping (trees/sod/irrigation) is in progress

Colored concrete is in progress

AREA 1

Punch List corrections in progress

Tackable wall rework is in progress

AREA 2

Punch List corrections in progress

Tackable wall rework is in progress

Gym Bleacher installation is in progress

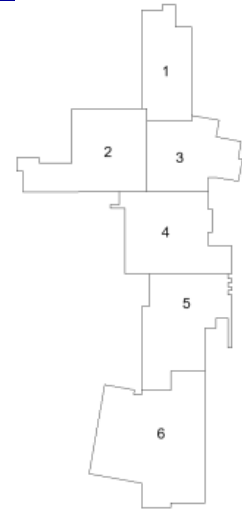

HS PHASE 1 AND 2 – CONSTRUCTION PHASE

WORK SUMMARY CONTINUED

AREA 3

Punch List corrections in progress

AREA 4

Ceiling grid installation is complete

Elevator installation is complete

Millwork installation is in progress

Interior storefront installation is in progress

Final polished concrete is in progress

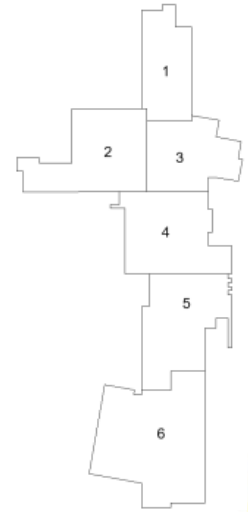

HS PHASE 1 AND 2 – CONSTRUCTION PHASE

WORK SUMMARY CONTINUED

AREA 5

Final polished concrete is in progress

Final paint is in progress

Kitchen equipment installation is in progress

AREA 6 PA WING

Millwork installation is in progress

Polished concrete is in progress

Final paint is in progress

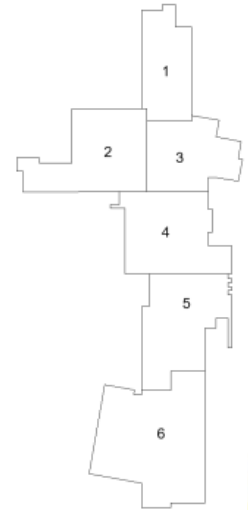

HS PHASE 1 AND 2 – CONSTRUCTION PHASE



EXTERIOR – SPED COURTYARD

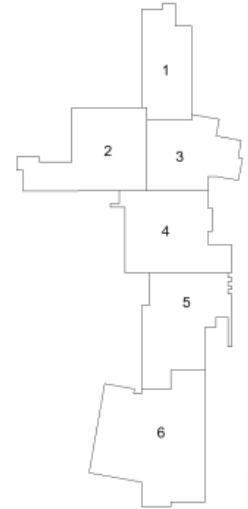

HS PHASE 1 AND 2 – CONSTRUCTION PHASE



EXTERIOR – MAIN ENTRY

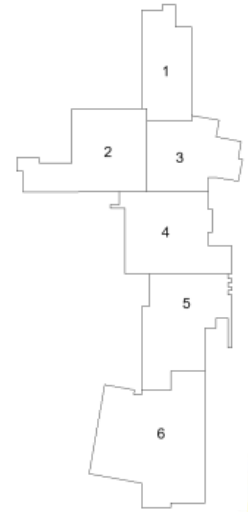

HS PHASE 1 AND 2 – CONSTRUCTION PHASE



EXTERIOR – BUS DROP-OFF / PIONEER PLAZA / SECONDARY ENTRY PAVING

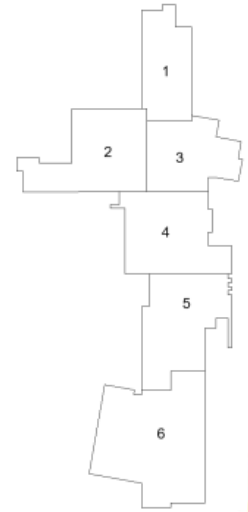

HS PHASE 1 AND 2 – CONSTRUCTION PHASE



EXTERIOR – VISUAL ARTS PLAZA AREA

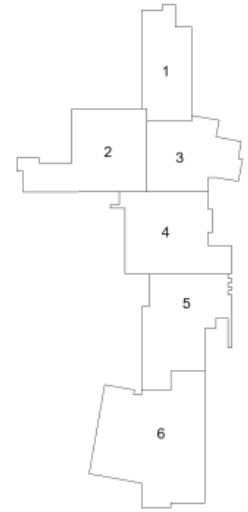

HS PHASE 1 AND 2 - CONSTRUCTION PHASE



STUDENT CENTER

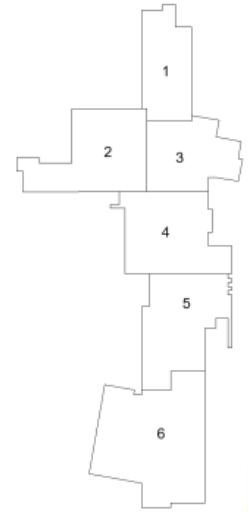

HS PHASE 1 AND 2 - CONSTRUCTION PHASE



STUDENT CENTER

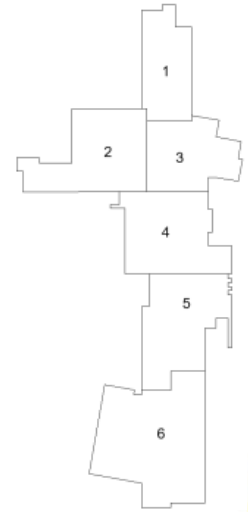

HS PHASE 1 AND 2 - CONSTRUCTION PHASE



STUDENT CENTER | TROPHY DISPLAY CASE

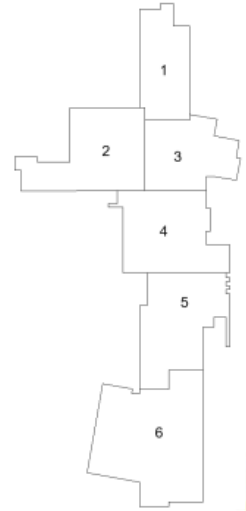

HS PHASE 1 AND 2 - CONSTRUCTION PHASE



COMMONS AREA 1ST FLOOR

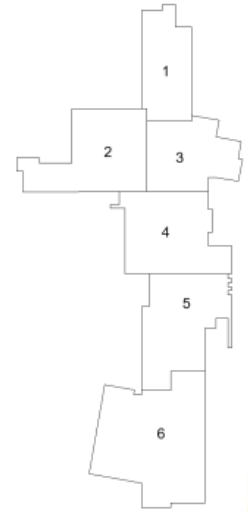

HS PHASE 1 AND 2 - CONSTRUCTION PHASE



COMMONS AREA 2ND FLOOR

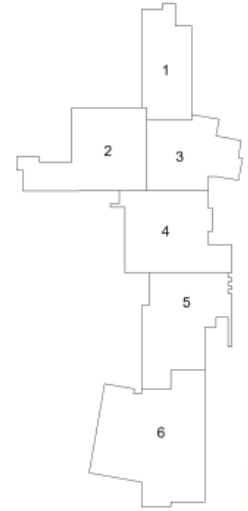

HS PHASE 1 AND 2 – CONSTRUCTION PHASE



TYPICAL STUDENT RESTROOM ENTRY

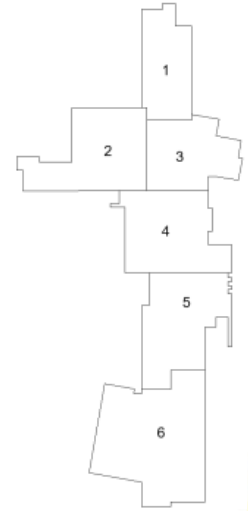

HS PHASE 1 AND 2 - CONSTRUCTION PHASE



STUDENT RESTROOM

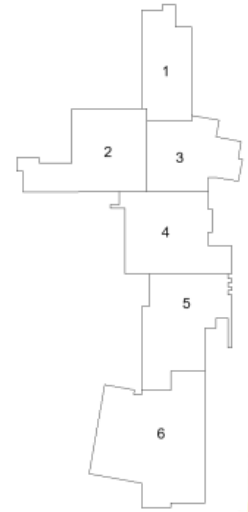

HS PHASE 1 AND 2 - CONSTRUCTION PHASE



MEDIA CENTER

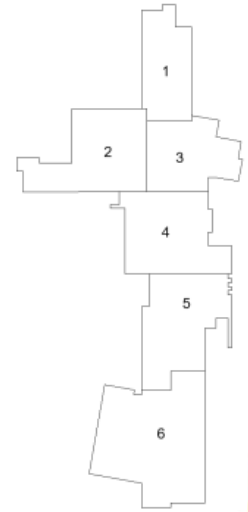

HS PHASE 1 AND 2 - CONSTRUCTION PHASE



MEDIA CENTER

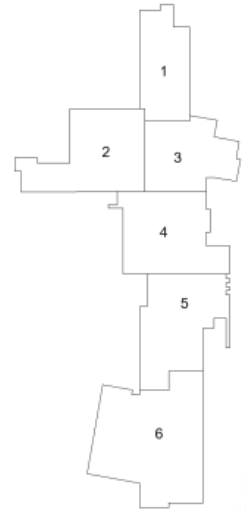

HS PHASE 1 AND 2 - CONSTRUCTION PHASE



MEDIA CENTER PATIO

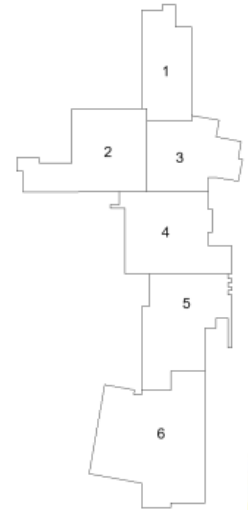

HS PHASE 1 AND 2 - CONSTRUCTION PHASE



DRAMA CLASSROOM

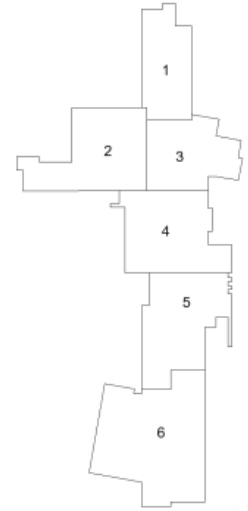

HS PHASE 1 AND 2 - CONSTRUCTION PHASE



PA WING LARGE BAND ROOM

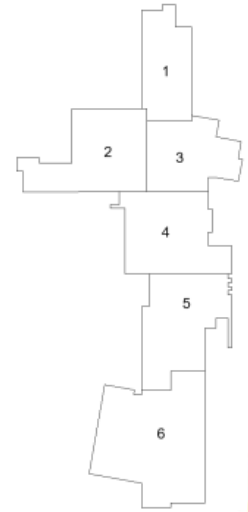

HS PHASE 1 AND 2 - CONSTRUCTION PHASE



PA WING CHOIR ROOM

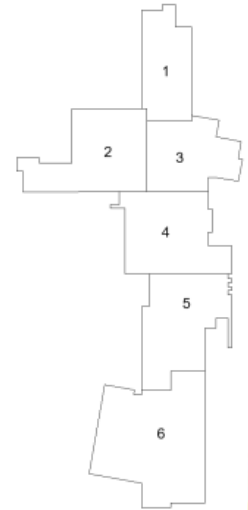

HS PHASE 1 AND 2 - CONSTRUCTION PHASE



PA WING COMMONS AREA

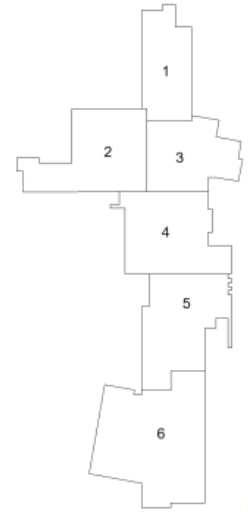

HS PHASE 1 AND 2 - CONSTRUCTION PHASE



FACS CLASSROOM

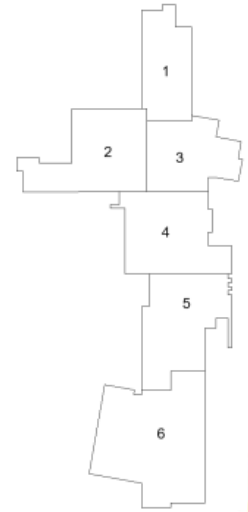

HS PHASE 1 AND 2 - CONSTRUCTION PHASE



FACS CULINARY CLASSROOM

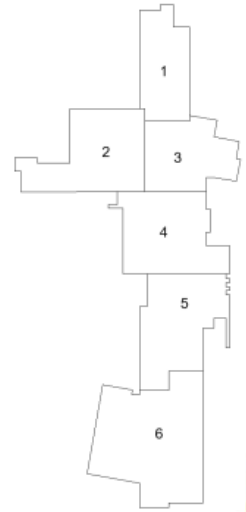

HS PHASE 1 AND 2 - CONSTRUCTION PHASE



GYMNASIUM

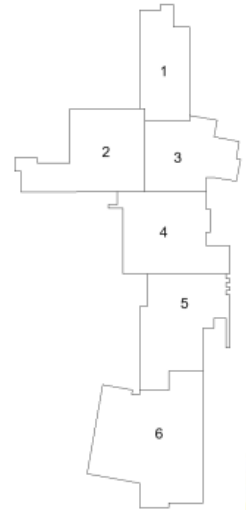

HS PHASE 1 AND 2 - CONSTRUCTION PHASE



GYMNASIUM

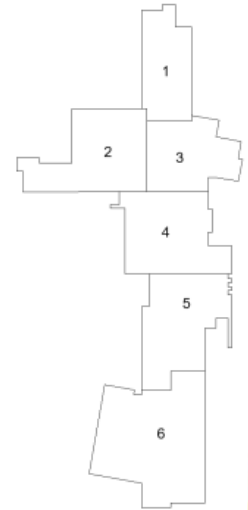

HS PHASE 1 AND 2 - CONSTRUCTION PHASE



VISUAL ARTS COMMON AREA

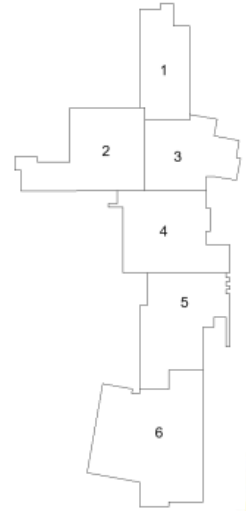

HS PHASE 1 AND 2 - CONSTRUCTION PHASE



VISUAL ARTS CLASSROOM

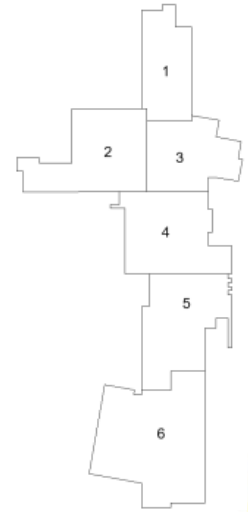

HS PHASE 1 AND 2 - CONSTRUCTION PHASE



SCIENCE LAB

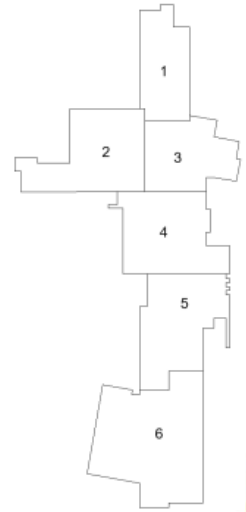

HS PHASE 1 AND 2 - CONSTRUCTION PHASE



SCIENCE LAB

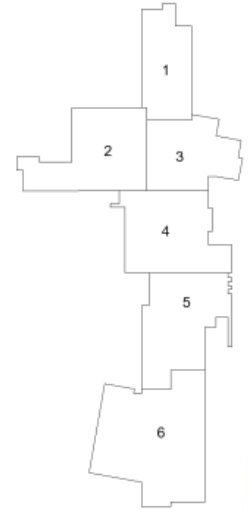

HS PHASE 1 AND 2 - CONSTRUCTION PHASE



ENTRY AREA

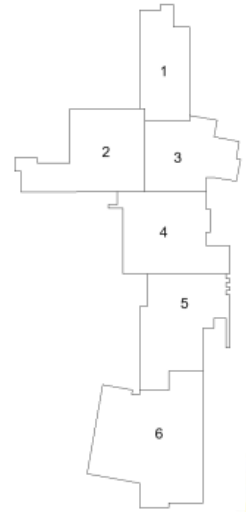

HS PHASE 1 AND 2 – CONSTRUCTION PHASE



RECEPTION AREA

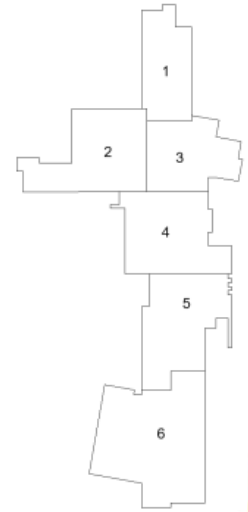

HS PHASE 1 AND 2 - CONSTRUCTION PHASE



SERVERY AREA

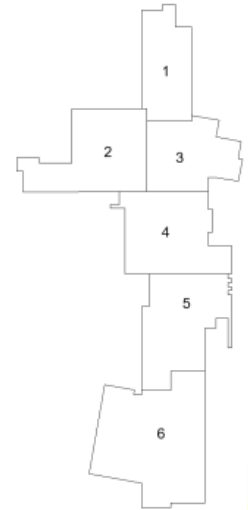

HS PHASE 1 AND 2 - CONSTRUCTION PHASE



KITCHEN

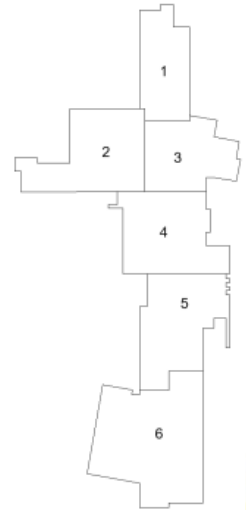

HS ATHLETICS PHASE 1 CD PHASE

SPS Athletics Phase 1 improvements on the existing High School campus that include new gym, weight room, wrestling, locker rooms, indoor practice spaces, outdoor practice field, and associated supports spaces. Project is in Construction Documentation (CD) Phase.

- 505 Architects will issue final Construction Documents for SPS Athletics Phase 1 Multi-Sport Building on 4/17 for Permitting and Bidding.
- Bids for SPS Athletics Phase 1 Multi-sport, Pom/Cheer, and Soccer and Track/Cross Country buildings will be brought to the June BOE for consideration and award.
- 505 Architects is working with SPS on development of the FF&E Package for SPS Athletics Phase 1.

HS ATHLETICS PHASE 1 CD PHASE

- SPS Athletics Phase 1 Early Demolition and Abatement Package construction has begun.
- SPS Athletics Phase 1 Early Civil and Landscape Package Bid on 3/26 with April 2026 BOE consideration to award bid. This package has been submitted for permitting on 2/23 and first round of comments have been received and responded to by 505 Architects.
- SPS Pom/Cheer Building and Soccer and Track/Cross Country Buildings have received building permits.





STILLWATER PUBLIC SCHOOLS



SCHOOL TRANSPORTATION

The Stillwater Board of Education recognizes that transportation is a necessary element of educational opportunity. The purpose of maintaining and operating a transportation system as part of the general school program shall be to provide its students adequate and safe transportation to and from school and on other school trips deemed a part of the educational program. Transportation is a privilege extended to students in the district only when necessary for the accomplishment of one of the following purposes:

1. To transport children whose homes are more than a reasonable walking distance, as defined by regulations of the State Board of Education, from the school attended by such child. Provisions of state law limit state funds paid for such transportation to a child residing at least one and one-half (1 ½) miles from the school attended. Except as otherwise provided by law for children with disabilities, students residing less than one and one-half (1 ½) miles from the school they attend are not eligible for school bus transportation services. Exceptions may be made, at the discretion of the transportation director, when no safe walking path exists.
2. To provide adequate education facilities and opportunities which otherwise would not be available.
3. For group movements within the state, for participants to and from contests, athletic games, or other school functions under the direct auspices of the board of education.

Stillwater Public Schools provides transportation services to ensure:

1. Children of our school district are transported in the safest manner possible.
2. Transportation services provided are cost effective to our district's taxpayers.
3. Transportation services are provided in an equitable manner.

Use of District Vehicle for Field Trips and Other Activities

School buses or other district-owned vehicles may be used for the transportation of students participating in school-sponsored activities under the following conditions:

- Bus or district-owned vehicle use for educational field trips and by student organizations is accepted as an extension of classroom activities. Adults may ride, if space allows, when they are designated as chaperones.
- When district-owned transportation is used, the student organization using the vehicles may be required to reimburse the district for all or part of the cost of the transportation.
- Advance consent of the student's parent or guardian is required for any excursion or field trip. Parents should be notified a minimum of three (3) days prior to any excursion that requires transportation away from the school campus. This notice may be provided by sending a Parent Permission for Field Trip form home with the student.
- Parental authorization forms and appropriate release forms (for each student) will be filed with the building principal prior to travel.
- Students participating in school sponsored activities are required to utilize school approved transportation with the following exceptions:

SCHOOL TRANSPORTATION (Cont.)

1. Activity sponsors may grant permission for students to return with parents.
 2. Parents may request in writing that their child ride to or from the event with another specified adult (non-SPS student). These requests will be approved by the administrator or designee on an individual basis.
- All field trips and excursions must be approved far enough in advance for proper consideration, approval, and preparation. This should be a minimum of seven (7) days.
 - Independently contracted transportation must be approved by the director of transportation.
 - Activities such as music, debate, band, orchestra, athletics and academic competition that are under the auspices of the Oklahoma Secondary School Activities Association have priority with regard to bus scheduling due to contractual commitments.
 - For non-required activity trips all buses must be available to run their regularly scheduled morning and afternoon routes, unless approved by the transportation director.
 - In the event that a scheduling conflict develops and cannot be resolved, the transportation director will determine priority. Date of request may not be the determining factor in such decisions.
 - If buses are not available for a requested trip, the transportation department will notify the site administrator as early as possible.
 - Sponsors, students and the driver are responsible for cleaning the bus at the conclusion of the trip.
 - When traveling out of district, each bus must have a minimum of two adult sponsors, at least one of which is a district employee. If the driver is a faculty sponsor, the driver may count as the district employee. A list of sponsors must be submitted to the appropriate administrator at least two (2) days prior to travel.

Out-of-State Travel

- Requests for out-of-state activity trips **should** be approved at least one month in advance by ~~the board of education~~ **Superintendent or designee**. Students will not travel out of state for school activities not approved by the ~~board of education~~ Superintendent.
- Individual drivers must follow these guidelines:
 1. May drive a maximum of ten (10) hours after a minimum of eight (8) hours off duty.
 2. May not drive more than eight (8) consecutive hours without at least a thirty (30) minute break.
 3. May not drive after having been on duty for fifteen (15) hours following a minimum of eight (8) hours off duty.
- If the above criteria guidelines cannot be met, two drivers per vehicle will be required.
- District-owned buses will not be used for trips in excess of 750 miles, one-way.

Other Uses of District-Owned Vehicles

District-owned vehicles may also be contracted for general public use including religious, political, literary, community, cultural, scientific, mechanical, agricultural, or parental involvement purposes. Such use shall be done at a reasonable charge to cover the cost of the use of school buses, other school transportation, and payment of school personnel to operate the vehicle.

All school vehicles will be driven by school personnel or volunteers who meet the guidelines established in policy CN-R1.

SCHOOL TRANSPORTATION (Cont.)

School Transportation Maintenance

For the health and safety of the students and staff of Stillwater Public Schools, school personnel are to maintain the mechanical systems of their assigned vehicles in like-new condition at all times. Each driver shall immediately report any defective condition of a school vehicle to the transportation department.

Drivers shall keep the interior and exterior clean. Vehicles should be washed as needed. Drivers are responsible for the condition of any school vehicle they are assigned, even though it may not be the one normally driven.

School buses shall be adequately maintained to provide safe transportation. Responsibilities of bus drivers in maintaining optimum efficiency of their assigned bus will include, but are not limited to, the following:

1. Inspect the bus daily and fill out the required inspection documentation as required by Oklahoma State Department of Education regulations.
2. Sweep out the bus after each trip and keep the bus fueled.
3. Suggest changes in bus routes that might save time, fuel, or wear and tear on the bus. Changes are not to be made without prior approval of the transportation director.

REFERENCE: 70 O.S. §9-104
70 O.S. §9-105
70 O.S. §9-108

CROSS-REFERENCE: Policy CN-R1, Requirements to Drive a Stillwater Public Schools Vehicle

ADMINISTERING MEDICATION TO STUDENTS (REGULATION)

1. Medication will be given only as authorized according to state law and district policy, regulations, guidelines and procedures.
2. Medication will be given by the school nurse, principal, designated employee or a contracted nurse
3. Students are NOT authorized to administer medication to other students.
4. Personal medication of employees will not be given to students.
5. An injected medication requires a medical monitoring plan, a physician's written authorization and a parent's/guardian's written permission.
6. Medication is only authorized to be administered when the Medication Authorization form is completed and signed. A new medication authorization form must be filled out for each medication at the beginning of the school year, when there is a medication change, and when there is a dosage change.
7. Physician changes or instructions may be faxed to the school site
8. Any unauthorized medication found at school will be confiscated. The parent/guardian will be notified and the incident and any action taken will be recorded and signed.
9. New/renewed prescriptions will be sent in the new/renewed prescription container.
10. School Nurse will decide whether or not a one-time dose of a medication will be administered.
11. Medication sent or brought to school in improper containers, improperly labeled, or not labeled will NOT be given even if the parent/guardian gives verbal or written authorization. The parent/guardian will be contacted and informed of SPS policy and procedures either verbally or in writing. The improperly packaged/labeled medication will be held until the end of the day and a parent/guardian will be required to come to the school to claim the medication. The process will be recorded and signed.
- ~~12. Medication may **only** be given to students who state they forgot to take their medication before coming to school if the parent/guardian is contacted and verbal authorization is given. This process must be recorded and signed. Medication will **not** be given if parent/guardian verbal authorization is unavailable.~~
13. Under no circumstances will one student's medication be given to another student.
14. All medication must be brought to the school by the parent/guardian. Students are NOT to bring medication to school.
15. Directions for administering medication must include specific times.
16. Inhalers may be kept with a student at all times and self-administered as the student deems necessary with written authorization by the parent/guardian AND physician. When an asthmatic has an inhaler, medication or a nebulizer at school, the parent/guardian will be required to fill out the SPS Asthma Information/Action form AND a Medication Authorization form.
17. Students under the age of 18 cannot terminate medications.
18. Expiration dates of medication will be tracked.
19. Medication from a foreign country will not be given.
20. Herbal/Homeopathic medications and health care products will follow the same guidelines as those in place for prescription/non-prescription medication.
21. For students who will self-carry/self-administer asthma medication, the SPS Self Administration of Inhaled Asthma Medication Policy will be followed.
22. Parent/Guardian requesting that a student be allowed to self-administer, self-carry other medication will be required to sign and have on file the Medication Authorization Form. The only other medication that a student can self-carry and self-administer besides asthma medication is medication used to treat anaphylaxis and medication used to treat diabetes, as students physician deems necessary and with appropriate written authorization.
23. Medications that require refrigeration will be kept in locked refrigerators.

ADMINISTERING MEDICATION TO STUDENTS, REGULATION (Cont.)

24. Medication taken on field trips must be in the original container **checked out from the health room or school nurse**, along with a copy of the signed Medication Authorization form. The designated teacher will be required to “check-out” the medication, keep the medication with him/her at all times, and record the Medication Authorization form after administering. All medication taken on field trips will be carried in a locked container.
25. **MEDICATION AUTHORIZATION FORM:** All medication administered must be recorded and signed by a designated employee on the back of the Medication Authorization form any time medication is administered. The employee’s full name must be used the first time medication is administered, but initials may be used on all other entries on that same form. When a parent/guardian brings the medication and form to school, the dosage, time(s) medication is to be taken, expiration date, date received and amount received must all be recorded on the back of the Medication Authorization form by the designated employee. The designated employee must also sign and record the date medication is returned to the parent/guardian, and amount returned to the parent/guardian.
26. **All students who require medication during school hours must have a completed Medication Authorization Form on file with the school. However, if a student has a Diabetic Medical Management Plan (DMMP) or a Seizure Action Plan (SAP), they may submit that plan in lieu of the Medication Authorization Form. These plans must be provided to the school, signed by the student’s healthcare provider, and include specific instructions regarding the administration of medication and other necessary care during school hours.**
27. 911 will be called as needed for potential reactions to medication.
28. If a medication error occurs, an accident report form will be filled out.
29. If a student refuses to take medication, the event will be recorded and the parent/guardian will be notified.
30. Parents will be required to pick up medication at the end of the school year. When medication is left at school, the parent/guardian will be notified that the medication needs to be picked up by a designated date.
31. For any medication left at school after the designated date, the medication will be retrieved by the school resource officer assigned to that school site and delivered to the medication drop-off location at the Stillwater Police Station.
32. To promote safety and consistency, one employee will be designated to administer medication. Other employees will be assigned the responsibility of administering medication when the designated employee is unavailable. Some school sites may have a contracted nurse authorized to give noon medication.
33. School nurses will train designated employees regarding medication policy and guidelines initially upon employment. School nurses will annually review and update designated employees regarding medication policy and guidelines. School Nurses will train and update annually designated employees regarding the procedures of emergency medication such as Glucagon, Epi-Pen, and Diastat.
34. School Nurses will monitor the administration of medication, authorization forms, logs, etc.
35. All medication issues are considered confidential.

**EXHIBIT A
PERSONNEL RECOMMENDATIONS
STILLWATER PUBLIC SCHOOLS
April 14, 2026**

A. CERTIFIED PERSONNEL

APPOINTMENT - 25 O.S. §307(B)(1)

Extra-Duty Stipend for the 2025-2026 School Year Subject to the Execution of an Extra-Duty Contract

<u>Name</u>	<u>Job Title</u>	<u>Site</u>	<u>Amount</u>
Davis, Caleb	Chess Club Section 3 Source of Funding: Westwood Elementary PTO	WW	\$600.00
Palmatary, Rebecca	Homebound Instruction Source of Funding: General Fund	JH	25.00/hour Not to exceed 24 hours
Allen, Samantha	Homebound Instruction Source of Funding: General Fund	JH	25.00/hour Not to exceed 95 hours
Daffern, Jennifer	Homebound Instruction Source of Funding: General Fund	MS	25.00/hour Not to exceed 190 hours
Weidner, Hillary	Homebound Instruction Source of Funding: General Fund	MS	25.00/hour Not to exceed 20 hours
Herring, Sean	Homebound Instruction Source of Funding: General Fund	JH	25.00/hour Not to exceed 30 hours
Varnum, Abby	Management of SPED Documents Source of Funding: General Fund	HP	1257.30
Dunn, Madilynn	STUCO Advisor Source of Funding: Activity Fund	HS	1000.00
Morrison, Amanda	Stop-Motion Animation Club Source of Funding: Skyline Elementary PTA	SK	375.00
Beverage, Christina	Theater Club Sponsor Source of Funding: Activity Fund	HP	600.00
Long, Taylor	Second Student Teaching Stipend Payment Source of Funding: OSDE	MS	1,625.00

Appointment Pursuant to Summer School Extra Duty for 2025-2026 School Year Pending Student Enrollm

<u>Name</u>	<u>Job Title</u>	<u>Site</u>	<u>Amount</u>
*TBA	ESY Special Education Teacher	JH	\$30.00/hour

Appointment for 2026-2027 School Year

*TBA

Education: Bachelors, Lipscomb University
Assignment: 1.000 FTE, Secondary Counselor, Stillwater High School
Beginning Date: TBD

*TBA

Education: Bachelors, Oklahoma State University
Assignment: 1.000 FTE, ELA Teacher, Stillwater High School
Beginning Date: TBD

Appointment for 2026-2027 School Year Pending Certification

*TBA

Education: Masters, Eastern Michigan University
Assignment: 1.000 FTE, Special Services, Sangre Ridge Elementary School
Beginning Date: TBD

*TBA

Education: Bachelors, Oklahoma State University
Assignment: 1.000 FTE, 3rd Grade Teacher, Sangre Ridge Elementary School
Beginning Date: TBD

*TBA

Education: Bachelors, Oklahoma State University
Assignment: 1.000 FTE, 3rd Grade Teacher, Sangre Ridge Elementary School
Beginning Date: TBD

*TBA

Education: Bachelors, Dordt College
Assignment: 1.000 FTE, Kindergarten Teacher, Sangre Ridge Elementary School
Beginning Date: TBD

Appointment Pursuant to Change in Contract for School Year 2026-2027

Jenkins, Rachel

Assignment: 1.000 FTE, Science Teacher, Stillwater High School
Beginning Date: TBD
Contract Days: 180
Was Science Teacher, Stillwater Middle School 2025-2026

Dunn, Madilyn

Assignment: 1.000 FTE, 1st Grade Teacher, Skyline Elementary School
Beginning Date: TBD
Contract Days: 180
Was 1st Grade Teacher, Highland Park Elementary School 2025-2026

Goad, Amy

Assignment: 1.000 FTE, Remedial Specialist, Westwood Elementary School
Beginning Date: TBD
Contract Days: 180
Was 3rd Grade Teacher, Westwood Elementary School 2025-2026

Martinez, Ashlyn

Assignment: 1.000 FTE, 3rd Grade Teacher, Richmond Elementary School
Beginning Date: TBD
Contract Days: 180
Was 4th Grade Teacher, Highland Park Elementary School 2025-2026

RESIGNATION - 25 O.S. §307(B)(1)

Resignation/Retirement

Ogle, Seana

Assignment: 1.000 FTE, Speech Pathologist, Westwood Elementary School

Beginning Date: August 8, 2007

Ending Date: May 21, 2026

Reason: Resignation

Scoville, Brooke

Assignment: 1.000 FTE, Grade 3 Teacher, Sangre Ridge Elementary School

Beginning Date: August 8, 2023

Ending Date: May 21, 2026

Reason: Resignation

Palmatary, Rebecca

Assignment: 1.000 FTE, STEM Teacher, Stillwater Junior High School

Beginning Date: August 14, 2006

Ending Date: May 21, 2026

Reason: Resignation

Blankenship, Caitlin

Assignment: 1.000 FTE, Grade 1 Teacher, Highland Park Elementary School

Beginning Date: August 9, 2021

Ending Date: May 21, 2026

Reason: Resignation

Murphy, Katie

Assignment: 1.000 FTE, Grade 1 Teacher, Richmond Elementary School

Beginning Date: August 8, 2018

Ending Date: May 21, 2026

Reason: Resignation

Walsh, Brooke

Assignment: 1.000 FTE, Grade 3 Teacher, Westwood Elementary School

Beginning Date: August 11, 2025

Ending Date: May 21, 2026

Reason: Resignation

Jeffrey, Abby

Assignment: 1.000 FTE, Grade 2 Teacher, Sangre Ridge Elementary School

Beginning Date: August 11, 2025

Ending Date: May 21, 2026

Reason: Resignation

Abbott, Bethani

Assignment: 1.000 FTE, Grade 3 Teacher, Richmond Elementary School

Beginning Date: August 9, 2021

Ending Date: May 21, 2026

Reason: Resignation

Hutchens, Karyn

Assignment: 1.000 FTE, Instructional Coach, Highland Park Elementary School

Beginning Date: August 14, 2017

Ending Date: May 21, 2026

Reason: Resignation

Marcum-Noftsger, Wendy
 Assignment: 1.000 FTE, Grade 1 Teacher, Westwood Elementary School
 Beginning Date: June 22, 1993
 Ending Date: May 21, 2026
 Reason: Retirement

Stokes, John
 Assignment: 1.000 FTE, Social Studies Teacher, Stillwater Junior High School
 Beginning Date: June 3, 1986
 Ending Date: May 21, 2026
 Reason: Retirement

King, Kelsie
 Assignment: 1.000 FTE, Pre-Kindergarten, Sangre Ridge Elementary School
 Beginning Date: August 8, 2023
 Ending Date: May 21, 2026
 Reason: Resignation

Nash, Marsha
 Assignment: 1.000 FTE, Special Services, Stillwater Junior High School
 Beginning Date: August 22, 1994
 Ending Date: May 21, 2026
 Reason: Retirement

B. SUPPORT PERSONNEL

APPOINTMENT - 25 O.S. §307(B)(1)

Appointment for the 2025-2026 School Year

<u>Name</u>	<u>Job Title</u>	<u>Site</u>	<u>Amount</u>
*TBA	Teacher Assistant-Academic and Behavioral Support	JH	\$14.77/hour
*TBA	Bus Driver	TR	16.57/hour
*TBA	Special Education Paraprofessional	SK	13.95/hour
*TBA	PALS Teacher Assistant	PALS	12.00/hour

Appointment Pursuant to Change in Contract for School Year 2025-2026

<u>Name</u>	<u>Job Title</u>	<u>Hours</u>	<u>Site</u>	<u>Amount</u>
Mahoney, Stephanie	Paraprofessional	4.00	HP	\$14.17/hour
To	Paraprofessional	7.00	HP	14.17/hour

Appointment for the 2026-2027 School Year

<u>Name</u>	<u>Job Title</u>	<u>Site</u>	<u>Amount</u>
*TBA	Server Administrator	IT	\$83,043.00

Extra-Duty Stipend for the 2025-2026 School Year Subject to the Execution of an At-Will Contract

<u>Name</u>	<u>Job Title</u>	<u>Site</u>	<u>Amount</u>
*TBA	Assistant Varsity Boys Soccer Source of Funding: General Fund -- August 2025 BOE Meeting Approved	HSA	\$2,500.00
*TBA	Head Tennis Coach Source of Funding: General Fund -- August 2025 BOE Meeting Approved	JHA	2500.00

*TBA	Assistant Tennis Coach	HSA	2000.00
	Source of Funding: General Fund -- August 2025 BOE Meeting Approved		
*TBA	Assistant Tennis Coach	JHA	1500.00
	Source of Funding: General Fund -- August 2025 BOE Meeting Approved		
*TBA	LETRS Trainer	ADM	25.00/hour
	Source of Funding: SRA		
*TBA	Server Administrator	IT	315.20/day
	Source of Funding: General Fund		

Appointment Pursuant to Summer School Extra Duty for 2025-2026 School Year Pending Student Enrollm

<u>Name</u>	<u>Job Title</u>	<u>Site</u>	<u>Amount</u>
*TBA	Summer Meals Manager	SNS	\$16.57/hour
*TBA	Summer Meals Manager	SNS	16.69/hour
*TBA	Summer Meals Kitchen Assistant	SNS	13.37/hour
*TBA	Summer Meals Kitchen Assistant	SNS	15.44/hour
*TBA	Summer Meals Kitchen Assistant	SNS	14.94/hour
*TBA	Summer Meals Kitchen Assistant	SNS	13.50/hour
*TBA	Summer Meals Kitchen Assistant	SNS	13.50/hour
*TBA	Summer Meals Kitchen Assistant	SNS	15.09/hour
*TBA	Summer Meals Kitchen Assistant	SNS	13.37/hour
*TBA	Summer Meals Kitchen Assistant	SNS	13.37/hour
*TBA	Summer Meals Kitchen Assistant	SNS	13.37/hour
*TBA	Summer Meals Kitchen Assistant	SNS	13.37/hour
*TBA	Summer Meals Bus Driver Substitute	SNS	18.10/hour
*TBA	Summer Bus Aide	TR	13.86/hour
*TBA	Summer Transportation Dispatcher	TR	20.19/hour
*TBA	Summer Bus Driver	TR	18.60/hour
*TBA	Summer Bus Driver	TR	19.29/hour
*TBA	Summer Bus Driver	TR	17.62/hour
*TBA	Summer Book Bus Driver	TR	17.77/hour

RESIGNATION - 25 O.S. §307(B)(1)

Resignation/Retirement

<u>Name</u>	<u>Job Title</u>	<u>Hours</u>	<u>Site</u>	<u>Effective</u>
Adams, Cheryl	Teacher Assistant - PreK	7.00	RI	5/20/2026
Brandly, Jimmy	Head Custodian	8.00	FAC	6/5/2026
Fishburn, Courtney	Teacher Assistant - PreK	7.00	SR	5/20/2026
Gardner, Marvin	Bus Driver	6.00	TR	3/6/2026
Harris, Haven	Custodian	8.00	FAC	4/6/2026
Hicks, Melissa	Teacher Assistant - PreK	7.00	SR	5/20/2026
Hockensmith, Elsie	Custodian	8.00	FAC	3/31/2026
Jolliff, Pam	Principal Secretary	8.00	MS	6/5/2026
Mahmoud, Mariam	Noon Monitor	3.00	HP	5/20/2026
Nassab, Dina	Paraprofessional	7.00	RI	4/2/2026
Nickens, Joleyn	Paraprofessional	7.00	HP	5/20/2026
Short, Rick	Building/Grounds Supervisor	8.00	FAC	6/5/2026
Stokes, John	Activity Driver		TR	5/21/2026
Timmerman, Kelsey	Teacher Assistant - Academic Support	7.00	HP	5/20/2026

C. ADMINISTRATIVE PERSONNEL

APPOINTMENT - 25 O.S. §307(B)(1)

Appointment for the 2025-2026 School Year

*TBA

Assignment: 1.000 FTE, Director of Technology, Stillwater Public Schools

Beginning Date: TBD

Salary: \$87,890.00

Was 1.000 FTE, Technology Integration Coordinator, Stillwater Public Schools

Extra-Duty Stipend for the 2025-2026 School Year Subject to the Execution of an Extra-Duty Contract

<u>Name</u>	<u>Job Title</u>	<u>Site</u>	<u>Amount</u>
Cawood, Joy	District LETRS Facilitator	RI	\$600.00
		Source of Funding: SRA	
Nelson, Darren	Summer School Administrator-SHS Credit Recovery Progr	JH	45.00/hour
	Pending Student Enrollment	Source of Funding: General Fund	

EMPLOYMENT - 25 O.S. §307(B)(1)

Rehire for 2026-2027 School Year

Cawood, Chad	Jackson, Jackie
Cawood, Joy	Lamecker, Rob
Clark, Claire	McBee, Elizabeth
Dobbs, Ashley	Moore, Ashley
Dyson, Rebecca	Neal, Krista
Elghadi, Adam	Nelson, Darren
Elliott, Brenda	Newby, Kristie
Fix, Diane	Oller, Mason
Fluty, Natalie	Parsel, Matt
Frisby, Kira	Patzkowski, Cami
Fuxa, Barry	Reece, Rebekah
Gamble, Robert	Rhoades, Angela
Grant, Tommie	Riggs, Jason
Harris, Emily	Sallaska, Dane
Hayes, Johnna	Self, Kristy
Heid, Doug	Swanson, Trent
Horton, George	Todhunter, Madison
Howell IV, Walter	Treat, Carl
Hula, Austin	Warwick, Brian
Hutson, Christina	

D. SUBSTITUTES

APPOINTMENT - 25 O.S. §307(B)(1)

Bus Driver Substitute

*TBA

Teacher Substitute

*TBA

*TBA

*TBA

*TBA

*TBA

*TBA

*TBA

*TBA

s

ient

ient