

Regular School Board Meeting  
Monday, May 11, 2026 5:30 PM

Austin High School Annex Recital Hall  
205 4th Street NW, Annex Door #1  
Austin, MN 55912

## **Agenda**

1. Call to Order/Roll Call  
**Speaker(s):** Chairperson Dube
2. Pledge of Allegiance
3. Approval of Agenda (Action)  
**Speaker(s):** Chairperson Dube
4. PUBLIC HEARING
  - 4.A. Request for approval of tax abatement request from New Horizon Homes (PIN 34.468.0100) (Action)  
**Speaker(s):** Exec Director of Finance and Operations Todd Lechtenberg
  - 4.B. Request for approval of tax abatement request from Bigelow & Lennon Construction LLC (PIN 34.523.0270) (Action)  
**Speaker(s):** Exec Director of Finance and Operations Todd Lechtenberg
5. Recognition of Student School Board Representatives  
**Speaker(s):** Chairperson Dube
6. Superintendent's Report  
**Speaker(s):** Superintendent Dr. Joey Page
7. School Board Reports
8. Student Representative Reports  
**Speaker(s):** Lydia Masara and Michael Garry
9. Consent Agenda (Action)  
**Speaker(s):** Chairperson Dube
  - 9.A. Regular meeting minutes of 04/13/26
  - 9.B. Study session meeting minutes of 04/27/26
  - 9.C. Personnel - May 2026
  - 9.D. Bills as of 05/11/26
  - 9.E. Treasurer's Report - March 2026
  - 9.F. Principals contract approval
  - 9.G. Arux scheduling software approval
  - 9.H. Kelly Services for substitute staffing
  - 9.I. Red Rover software approval
  - 9.J. Cabinet reports
    - 9.J.1. Academics and Administrative Services
    - 9.J.2. Finance and Operations
    - 9.J.3. Information Services
    - 9.J.4. Special Services
    - 9.J.5. Technology Services
  - 9.K. APS site reports
10. The Hormel Foundation Austin Assurance Scholarship update  
**Speaker(s):** Riverland Program Coordinator Taylor Flugge

11. Packer Profile update  
**Speaker(s):** AHS Principal Matt Schmit, AOA/ALC Principal Dr. Jessica Cabeen, Packer Profile Coordinator Emily Hovland and Student Talan Hall
12. Request approval of clerical staff lay off resolution (Action)  
**Speaker(s):** Human Resources Director Sue Stark
13. Request approval of resolution regarding custodial position elimination, staff reassignment and staff lay off (Action)  
**Speaker(s):** Human Resources Director Sue Stark
14. Request approval of Unrequested Leave of Absence - Asst Prin (Action)  
**Speaker(s):** Human Resources Director Sue Stark
15. Request approval of donations (Action)  
**Speaker(s):** Exec Director of Finance and Operations Todd Lechtenberg
16. Request approval of LEA (Local Educational Agency) - Title grants representative for 2026-27 (Action)  
**Speaker(s):** Superintendent Dr. Joey Page
17. Request approval to appoint Dr. Joey Page as Identified Official with Authority (IoWA) for 2026-27 (Action)  
**Speaker(s):** Chairperson Dube
18. Delegations
19. Reminder of school board special meeting scheduled for Tuesday, May 26, 2026 in the District Office Conference Room  
**Speaker(s):** Chairperson Dube
20. Adjournment (Action)

# HOUSING TAX ABATEMENT APPLICATION

(Application Period 1-1-2023 through 12-31-2025)

Property Owner / Applicant: New Horizon Homes

Current Address: 25388 670th St, Kasson, MN, 55944, USA

Telephone: 507-250-3069

E-Mail: Newhorizonhomes.jon@gmail.com

Has applicant ever defaulted on property taxes? No

*If Yes, provide details on separate page(s).*

Are property taxes current? Yes

PROJECT <span style="font-size: small;">(check all that apply)</span>	
Single-Family	Multi-family Complex
New Construction	
Is this an application for a replacement of an existing housing unit on the same parcel? <u>No</u>	
Is this application for an existing housing unit you intend to move to this parcel? <u>No</u>	
If YES, where is the unit being relocated from?	
Project Address: <u>1304 17TH ST NE</u>	<u>AUSTIN MN 55912</u>
Project Legal Description: <u>Block 001 Lot 010 SubdivisionCd 34468 SubdivisionName NATURE RIDGE THIRD</u>	
Parcel Number: <u>34.468.0100</u>	Est. Project Valuation: <u>\$ 400,000</u>

**Attach** building plans, site plan, certification from zoning entity that housing project complies with zoning regulations and there are no outstanding land use issues. (Include letter of consent from property owner if subject to purchase agreement or include a copy of the purchase agreement.)

*I / We as applicant(s) for the Housing Tax Abatement submit this application having read the policy and understand the provisions as outlined including, but not limited to, the potential of a partial abatement in year one, due to % of completion on January 2<sup>nd</sup>, there are not any non-compliance or non-conformity outstanding land use issues on the parcel, construction must commence within one year of the approval, assessors cannot be refused access to the property for assessment purposes and the abatement is awarded annually following full payment of real estate taxes due.*

***New Horizon Homes - Applicant submitted via online form and agreed to conditions above 04/23/2026***

*Signature of Applicant(s)*

*Date*

**FOR OFFICE USE ONLY:**

**ELIGIBLE / APPLICABLE APPROVALS**

Mower County

Date:

City or  Township of

Date:

School District of

Date:

**Disclaimer:** Each taxing entity makes its own decision on approval or denial of application for tax abatement. Applications must comply with all requirements of the policy/program as outlined in the policy/program guidelines and build within allotted timeframe or tax abatement offer will be automatically terminated.

**Notice - City of Austin Housing Projects** This application must be approved prior to the building permit being issued by the City of Austin.





NOTE: WDWS WIDER THAN 4'-1"  
TO HAVE 2-2X6 TRIMMER

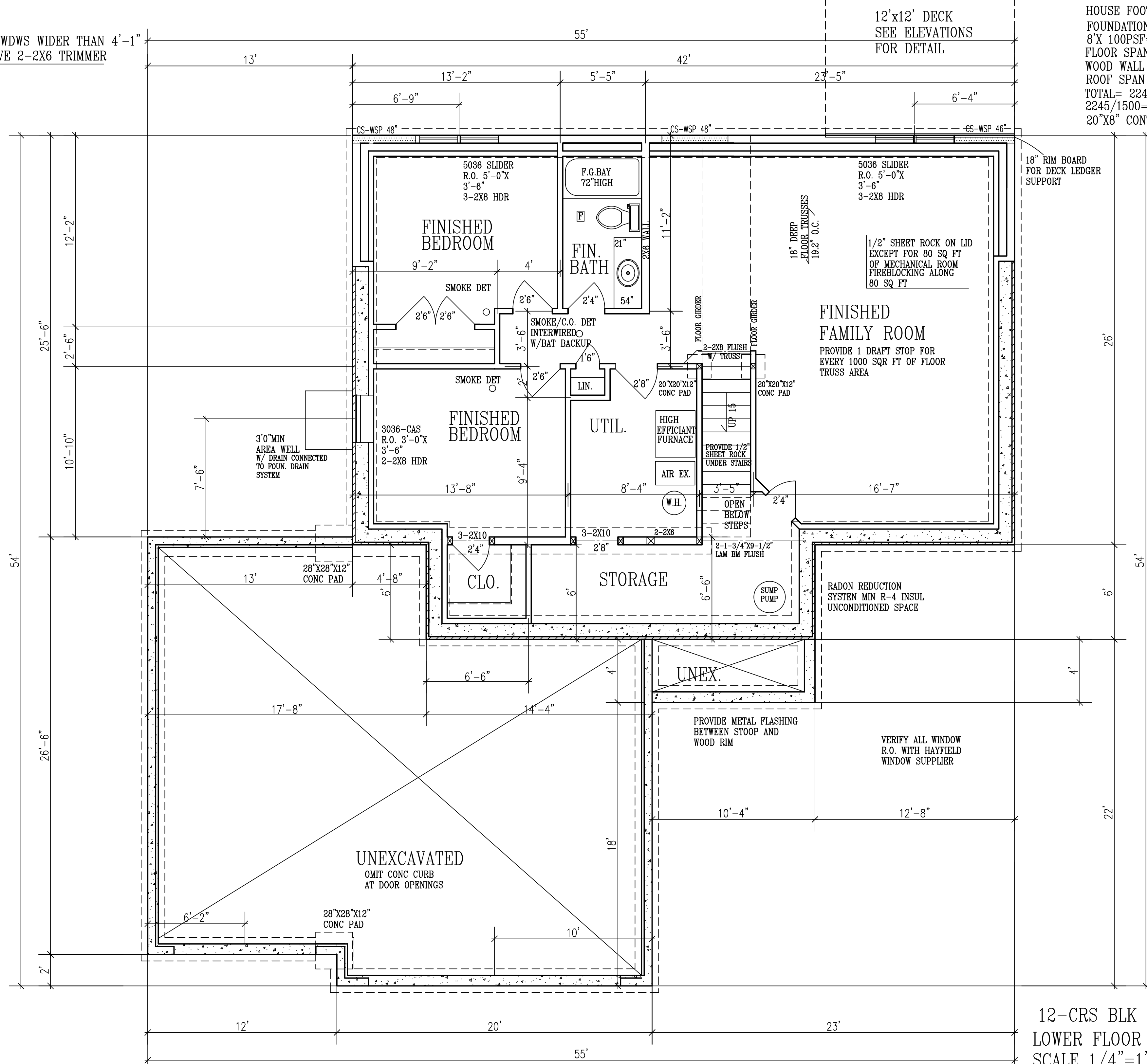

12'x12' DECK  
SEE ELEVATIONS  
FOR DETAIL

HOUSE FOOTINGS  
FOUNDATION WALL 8' TALL @ 100#SF  
8'X 100PSF= 800PLF  
FLOOR SPAN 26' 13'X50PSF=650PLF  
WOOD WALL 8' TALL 8X10#=80PLF  
ROOF SPAN 26'-0" 13'X55PSF=715PLF  
TOTAL= 2245PLF  
2245/1500=1.49'  
20"X8" CONT CONC FOOTING

18" RIM BOARD  
FOR DECK LEDGER  
SUPPORT

FINISHED  
FAMILY ROOM  
PROVIDE 1 DRAFT STOP FOR  
EVERY 1000 SQR FT OF FLOOR  
TRUSS AREA

1/2" SHEET ROCK ON LID  
EXCEPT FOR 80 SQ FT  
OF MECHANICAL ROOM  
FIREBLOCKING ALONG  
80 SQ FT

3'0" MIN  
AREA WELL  
W/ DRAIN CONNECTED  
TO FOUN. DRAIN  
SYSTEM

RADON REDUCTION  
SYSTEM MIN R-4 INSUL  
UNCONDITIONED SPACE

UNEXCAVATED  
OMIT CONC CURB  
AT DOOR OPENINGS

PROVIDE METAL FLASHING  
BETWEEN STOOP AND  
WOOD RIM

VERIFY ALL WINDOW  
R.O. WITH HAYFIELD  
WINDOW SUPPLIER

12-CRS BLK  
LOWER FLOOR PLAN  
SCALE 1/4"=1'-0"

PROGRESSIVE PLAN  
DESIGN LLP

RESIDENTIAL ARCHITECTURE  
714 County RD. 3 NW Byron MN, 56220  
(507-775-6877) progressiveplandesign@gmail.com

These drawings have been prepared using information provided by the customer/contractor who is solely responsible for the accuracy of the information provided. The drawings are not a substitute for permit drawings and shall not be used for construction without the approval of the local building department. Before starting construction, the customer should consult a contractor familiar with local building codes and regulations. 2. project structural requirements. 3. existing conditions specific to project of project site. Consult local building officials to determine if a building permit is required. We assume no responsibility for claims or damages arising from errors, omissions, deficiencies, improper construction, or defects of the drawings.  
Acknowledged by \_\_\_\_\_ Customer/Contractor Signature \_\_\_\_\_ Date \_\_\_\_\_

CONTRACTOR:  
VALLEY HOME IMPROVEMENT

OWNER:  
BUCKNELL FIRST  
LOT#1 BLOCK#1

DRAWN BY:	R.H.
DATE:	
SQ. FT.	1241
JOB NUM.	2615104
SCALE:	NOTED
SHEET:	OF:
1/4"=1'0" 18x24	

NOTE: WDWS WIDER THAN 4'-1" TO HAVE 2-2X6 TRIMMER

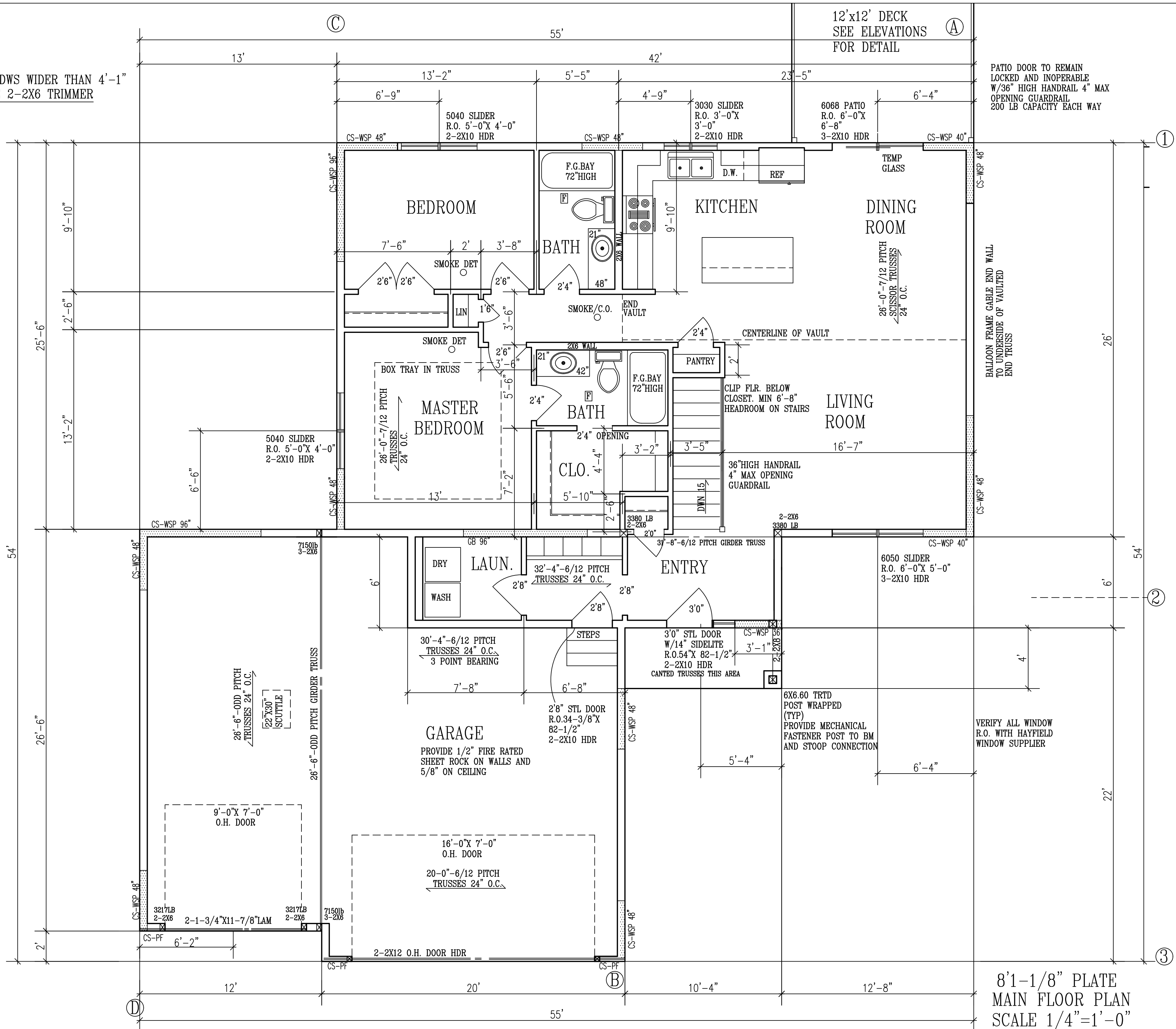

8'1-1/8" PLATE  
MAIN FLOOR PLAN  
SCALE 1/4"=1'-0"

**PROGRESSIVE PLAN  
DESIGN LLP**  
RESIDENTIAL ARCHITECTURE  
714 County RD. 3 NW Byron MN, 56220  
(507-775-6677) progressiveplandesign@gmail.com

These drawings have been prepared using information provided by the customer/contractor who is solely responsible for the accuracy of the information provided. The drawings are not a substitute for permit drawings prepared by a contractor or architect and may not meet all applicable codes and practices. Before starting construction, the customer should consult a contractor or architect to determine if the drawings meet all applicable codes and practices. The contractor is responsible for obtaining all necessary permits, licenses, and approvals. The customer is responsible for providing all necessary information and materials. The contractor is responsible for the construction of the project. The customer is responsible for the completion of the project. The contractor is responsible for the quality of the work. The customer is responsible for the safety of the project. The contractor is responsible for the schedule of the project. The customer is responsible for the budget of the project. The contractor is responsible for the communication of the project. The customer is responsible for the coordination of the project. The contractor is responsible for the execution of the project. The customer is responsible for the acceptance of the project. The contractor is responsible for the delivery of the project. The customer is responsible for the payment of the project. The contractor is responsible for the completion of the project. The customer is responsible for the satisfaction of the project. The contractor is responsible for the quality of the work. The customer is responsible for the safety of the project. The contractor is responsible for the schedule of the project. The customer is responsible for the budget of the project. The contractor is responsible for the communication of the project. The customer is responsible for the coordination of the project. The contractor is responsible for the execution of the project. The customer is responsible for the acceptance of the project. The contractor is responsible for the delivery of the project. The customer is responsible for the payment of the project. The contractor is responsible for the completion of the project. The customer is responsible for the satisfaction of the project.

**CONTRACTOR:**  
VALLEY HOME IMPROVEMENT

**OWNER:**  
BUCKNELL FIRST  
LOT#1 BLOCK#1

**DRAWN BY:**  
R.H.

**DATE:**

**SQ. FT.:** 1241

**JOB NUM.:** 2615104

**SCALE:** NOTED

**SHEET:**

1/4"=1'0" 18x24

Customer/Contractor Signature \_\_\_\_\_ Date \_\_\_\_\_

**ROOF SYSTEM:**

- TRUSSES 24" O.C. SPECS BY MFG.
- 1/2" OSB ROOF SHEATHING P.I.I. 32/16
- WINTERGUARD APPLIED SHINGLE FASHION TO A POINT 24" INSIDE EXTERIOR WALL. 15# FELT ON REMAINING.
- 20 YEAR 3 TAB ASPHALT SHINGLES
- PROVIDE STEEL SUPPLEMENTAL UPLIFT BRACKETS FOR ALL TRUSSES.
- PROVIDE CLIPS AS REQUIRED FOR ROOF SHEATHING

**WINDWASH BARRIER:**

- AT EXTERIOR EDGE OF ATTIC INSULATION. A MINIMUM OF 1" OF AIR SPACE SHALL BE PROVIDED BETWEEN INSUL AND SHEATHING.

**EAVE SYSTEM:**

- 2X6 SUBFASCIA
- ALUMINUM FASCIA
- 2X4 LOOKOUTS 24" O.C.
- ALUMINUM SOFFIT W/CANT VENT
- AIR CHUTES 48" O.C.

**GUARDRAIL**

- GUARDS ARE TO WITHSTAND A 200 LB. LOAD IN ANY DIRECTION TABLE: IRC R301.5
- GUARDS REQUIRED FOR PORCHES, BALCONIES OR RAISED FLOOR SURFACES LOCATED MORE THAN 36" IN HEIGHT. OPEN SIDES OF STAIRS WITH A TOTAL RISE OF MORE THAN 30" ABOVE THE FLOOR OR GRADE BELOW SHALL HAVE GUARDS NOT LESS THAN 34" IN HEIGHT MEASURED VERTICALLY FROM THE MOSING OF THE TREADS.
- GUARD OPENING LIMITATIONS. REQUIRED GUARDS ON OPEN SIDES OF STAIRWAYS, RAISED FLOOR AREAS, BALCONIES AND PORCHES SHALL HAVE INTERMEDIATE RAILS OR ORNAMENTAL CLOSURES THAT DO NOT ALLOW PASSAGE OF A SPHERE 4" IN DIA.
- EXCEPTION: THE TRIANGULAR OPENINGS FORMED BY THE RISER, TREAD AND BOTTOM RAIL OF A GUARD AT THE OPEN SIDE OF A STAIRWAY ARE PERMITTED TO BE OF SUCH A SIZE THAT A SPHERE 6" CANNOT PASS THROUGH.

**GENERAL NOTES:**

- 115 MPH WIND LOAD
- FLR 40lb LL-10lb DL= 50 TL
- ROOF 35lb LL-17lb DL= 52 TL
- IRC R502.11.3 TRUSS MEMBERS AND COMPONENTS SHALL NOT BE CUT, NOTCHED, SPLICED OR OTHERWISE ALTERED IN ANY WAY WITHOUT APPROVAL OF A REGISTERED DESIGN PROFESSIONAL.
- FOUNDATION- MIN 3000 P.S.I. AIR ENTRAINED CONC.
- FOOTINGS- MIN 5000 P.S.I.
- PLAIN CONCRETE- 2000 P.S.I.
- REROD- MIN GRADE 60
- FOOTINGS TO BEAR ON ORIGINAL SOIL.
- WOOD FRAMING 2X4, 2X6 STD #2 GRADE OR BETTER
- BRIDGING AT CENTERLINE OF SPANS.
- PROVIDE SOLID BLOCKING AT FLOOR JSTS BEARING POINTS, INTERIOR BEARING WALLS AND CANTILEVERED FLOOR JOISTS AS REQUIRED.
- PROVIDE RIGID AIR BARRIER AT ALL PLUMBING AND MECHANICAL HEAT DUCT PENETRATIONS OF EXTERIOR WALLS, CEILINGS, AND FLOORS.
- 16"x16" PLUMBING ACCESS PANEL. PROVIDE A M.R. AIR BARRIER AT THE INSIDE SURFACE OF EXTERIOR ENVELOPE BEHIND TUB AND SHOWER UNITS. (1/2" AWW PLYWD.) DUROC OR 5/8" W.R. GYP. TO 72" WHEN & WHERE REQ.
- SHEATHING JOINTS WHICH ARE NOT SUPPORTED BY FRAMING MEMBERS MUST BE CAULKED.
- ALL PENETRATIONS INSTALLED THROUGH THE INTERIOR AIR BARRIER MUST BE SEALED PRIOR TO THE FRAMING INSPECTION.
- ADD 1/2" TO ALL WINDOW ROUGH OPENINGS FOR INSUL.
- MINIMUM BSMNT CEILING HGTS. 7'0" MIN.
- WINDOWS AND DOORS ARE TO BE SEALED TO PREVENT THE ENTRY OF OUTSIDE AIR. SEE MFG'S INSTALLATION.

**EXTERIOR WALL:**

- SIDING NOTED ON ELEVATIONS
- TYVEK OR TYPAR HOUSE WRAP TO UNDERSIDE OF TOP CHORD OF TRUSS OR RAFTER.
- 7/16" OSB. WALL SHEATHING
- 2X6 STUDS 16" O.C.
- 5-1/2" F.F. INSULATION R-20
- 4 MIL POLY PERM VAPOR BARRIER TAPED @ JOINTS
- 1/2" SHEET ROCK
- 2-2X12 HDRS ON ALL OPENINGS UNLESS OTHERWISE NOTED.

**FIREBLOCKING AND DRAFTSTOPS:**

- PROVIDE IN CONCEALED SPACES OF STUD WALLS AND PARTITIONS INCLUDING FURRED SPACES AT CEILINGS AND FLOOR VEVELS AT 10' INTERVALS BOTH VERTICAL AND HORIZONTAL.

WDWS U.	.31
R.	.61 STEEL SIDING
R.	.06 TYVEK
R.	.54 7/16" STRUCT. PANEL (R. 9.44) 2x6 STUDS @ 16" O.C.
R.	20.00 5-1/2" F.G. INSUL.
R.	.06 6 MIL. POLY V.B.
R.	.45 1/2" GYP. BD.
R.	.85 AIR FILMS
R.	22.57 TOTAL WALL

**RADON VENT:**

HOLLOW BLK FOUNDATION WALLS SHALL BE CONSTRUCTED WITH EITHER A CONT. CRS OF SOLID MASONRY, OR 1 CRS MASORY GROUDED SOLID, OR SOLID CONC BM, AT OR ABOVE FINISHED GRADE TO PREVENT PASSAGE OF AIR FROM INTERIOR OF THE WALL INTO LIVING SPACE. WHERE BRICK LEDGE IS INSTALLED, THE CRS IMMEDIATELY BELOW THAT LEDGE SHALL BE SEALED. JOINTS, CRACKS, OR OTHER OPENINGS AROUND PENETRATIONS OF BOTH EXTERIOR AND INTERIOR SURFACES OF MASONARY WALL. WOOD FOUNDATION WALLS BELOW GRADE SURFACE SHALL BE FILLED WITH POLYURETHANE CAULK. MIN 3" ABS,PVC,OR EQUIVALENT GASIGHT PIPE SHALL BE EMBEDDED VERTICALLY INTO SUB SLAB AGGREGATED OR OTHER PERMIABLE MATERIAL A "T" FITTING WITH ONE 10' SECTION OF PERFORATED PIPE CONNECTED TO EACH SIDE OF "T" OR 3" PIPE SHALL BE INSERTED INTO INTERIOR PERIMETER DRAIN TILE LOOP OR THROUGH A SEALED SUMP COVER. WHERE THE SUMP IS EXPOSED TO THE SUB-SLAB AGGREGATE. RADON VENTS SHALL CONNECT TO SINGLE PIPE THAT TERMINATES AT LEAST 12' ABOVE ROOF. RADON PIPES SHALL PROVIDE ENOUGH SPACE AROUND PIPE FOR REQ FAN, MIN 24" DIA. CENTERED ON AXIS OF VENT STACK A MIN VERTICAL DISTANCE OF 36". RADON PIPES SHALL BE IDENTIFIED WITH ONE LABEL ON EACH FLOOR, LABEL SHALL READ(RADON REDUCTION SYSTEM)

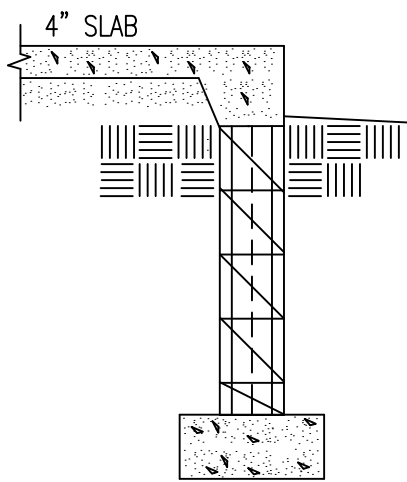

**STOOP**

- 18"x8" CONTINUOUS CONC FOOTING
- 2-#4 REROD CONT
- 4-1/2 CRS 8" CONC BLOCK
- #4 REROD 48" O.C. VERT FULLY GROUDED CORES MIN 7" EMBEDMENT
- MIN 40 BAR DIA LAP ALL VERTICAL REINFORCEMENT SPLICES

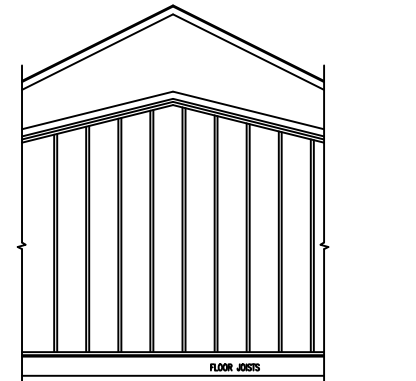

WHEN SCISSOR TRUSSES ARE USED THE GABLE END FRAME SHALL MATCH THE PROFILE OF THE SCISSOR TRUSSES ADJACENT TO IT FOR PROPER BOTTOM CHORD PLANE BRACING TO BE INSTALLED

**TEMPERED GLASS IRC R308.4:**

- GLAZING, IN AN INDIVIDUAL FIXED OR OPERABLE PANEL ADJACENT TO A DOOR WHERE THE NEAREST VERTICAL EDGE IS WITHIN A 24" ARC OF THE DOOR AND IS LESS THAN 60" ABOVE THE FLOOR OR WALKING SURFACE. GLAZING IN AN INDIVIDUAL FIXED OR OPERABLE PANEL, OTHER THAN THOSE LOCATIONS DESCRIBED IN ITEM 5 AND 6 ABOVE, THAT MEETS ALL OF THE FOLLOWING CONDITIONS:
  - 7.1 EXPOSED AREA OF AN INDIVIDUAL PANE GREATER THAN 9 SQ. FT.
  - 7.2 BOTTOM EDGE LESS THAN 18" ABOVE THE FLOOR.
  - 7.3 TOP EDGE GREATER THAN 36" ABOVE THE FLOOR.
  - 7.4 ONE OR MORE WALKING SURFACES WITHIN 36" HORIZONTALLY OF THE GLAZING.

**FOAM PLASTIC**

SILL PLATES & HEADERS. FOAM PLASTIC SHALL BE PERMITTED TO BE SPRAY APPLIED (WITHOUT THERMAL BARRIER) TO A SILL PLATE AND HEADER (RIM) SUBJECT TO ALL OF THE FOLLOWING. THE MAXIMUM THICKNESS OF THE FOAM PLASTIC SHALL BE 3-1/4" THE DENSITY OF THE FOAM SHALL BE BETWEEN 1.5 TO 2.0 PCF. FLAME SPREAD INDEX OF 25 OR LESS AND A SMOKE DEVELOPED INDEX OF 450 OR LESS WHEN TESTED IN ACCORDANCE WITH ASTM E84

**FOAM PROTECTION**

- IF FOUNDATION WALL INSULATION IS ON THE EXTERIOR, THE PORTION FROM THE TOP OF THE FOUNDATION WALL TO SIX INCHES BELOW GRADE MUST BE COVERED BY AN APPROVED PROTECTIVE COATING.

**STAIR SYSTEM:**

- 3-2X12 STRINGERS D-FIR
- 1X8 PINE RISERS
- 5/4X 10" PARTIAL BOARD TREADS OR 2X10 HEM FIR SECURED TO STRINGERS W/4-16d CC NAILS PER STRINGER. PROVIDE HANDRAIL 34"-38" HIGH 36" HIGH GUARDRAIL W/4" MAX OPENINGS. 7-3/4" MAX RISE, 10" MIN RUN. 5/8" S.R. WALLS AND SOFFIT OF ENCLOSED UNSEABLE UNDERSTAIRS.
- 6"-8" MIN HEADROOM.

**LANDINGS**

- LANDINGS FOR STAIRWAYS: THERE SHALL BE A FLOOR OR LANDING AT THE TOP AND BOTTOM OF EACH STAIRWAY.
- EXCEPTION: AT THE TOP OF AN INTERIOR FLIGHT OF STAIRS, PROVIDED A DOOR DOES NOT SWING OVER THE STAIRS.
- LANDING AT DOORS: THERE SHALL BE A FLOOR OR LANDING ON EACH SIDE OF EACH EXTERIOR DOOR. THE FLOOR OR LANDING AT A DOOR SHALL NOT BE MORE THAN 1.5" LOWER THAN THE TOP OF THE THRESHOLD.
- EXCEPTION: AN EXTERIOR DR. SHALL NOT BE MORE THAN 7-3/4" BELOW THE TOP OF THE THRESHOLD, PROVIDED THE DOOR, OTHER THAN AN EXTERIOR STORM OR SCREEN DR. DOES NOT SWING OVER THE LANDING. THE WIDTH OF LANDING SHALL NOT BE LESS THAN THE STAIRWAY OR DR. SERVED. MIN. 36" IN THE DIRECTION OF TRAVEL.

**EMERGENCY ESCAPE WINDOWS: AND WINDOW WELL SPECS.**

- 5 SQ. FT. MIN. 20" WIDE, MIN. 24" HIGH CLEAR OPENING. WINDOWS PERMITTED AT GRADE LEVEL. GRADE LEVEL IS DEFINED AS THE WINDOW HAVING A SILL HGT. OF NOT MORE THAN 44" ABOVE OR BELOW GROUND LEVEL.
- MINNESOTA RULES, 1309.0310, SEC. R310.1 MIN. CEILING HGT. 36" MAINTAINED ABOVE EXTERIOR GRADE FROM EXTERIOR WALL TO PUBLIC WAY (I.E. UNDER DECKS OR CANT.)
- MIN 36" CLEAR SPACE IN FRONT OF WINDOW.
- WINDOW WELLS WITH A VERTICAL DEPTH GREATER THAN 44" BELOW THE ADJACENT GROUND LEVEL SHALL BE EQUIPPED WITH A PERMANENTLY AFFIXED LADDER OR STEPS USABLE WITH THE WINDOW IN THE FULLY OPEN POSITION. THE LADDER OR STAIRS SHALL BE PERMITTED TO ENCR OACH A MAXIMUM OF 6 INCHES. LADDERS OR RUNGS SHALL HAVE AN INSIDE WIDTH OF AT LEAST 12" AND SHALL PROJECT AT LEAST 3" FROM THE WALL AND SHALL BE SPACED NOT MORE THAN 18" ON CENTER VERTICALLY FOR THE FULL HEIGHT OF THE WINDOW WELL.

**FLASHING & COUNTERFLASHING**

- APPROVED CORROSION-RESISTIVE FLASHING SHALL BE PROVIDED IN THE EXTERIOR WALL ENVELOPE IN SUCH A MANNER AS TO PREVENT ENTRY OF WATER INTO THE WALL CAVITY OR PENETRATION OF WATER TO THE BUILDING STRUCTURAL FRAMING COMPONENTS. THE FLASHING SHALL EXTEND TO THE SURFACE OF THE EXTERIOR WALL FINISH AND BE INSTALLED TO PREVENT WATER FROM RE-ENTERING THE EXTERIOR WALL ENVELOPE.
- FLASHING SHALL BE INSTALLED CONTINUOUSLY ABOVE ALL PROJECTING WOOD TRIM.
- FLASHING SHALL BE INSTALLED AT WALL AND ROOF INTERSECTIONS.
- EXTEND DRIP CAPS PAST THE END OF THE BRICK MOLD AND BEND OVER.
- INSTALL KICK OUT FLASHING WHERE STEP FLASHING BEGINS.

**KNEEWALL FOUNDATION:**

- 20"x 8" CONT FOOTING
- FOOTING DOWELED TO BLOCK W/#4 VERT. REROD 48" O.C. MIN 20" ABOVE FTG. IN GROUDED CORE.
- W/6" 90 DEG. HOOK IN GROUDED CORE.
- 1-CRS 10"x4"x16" CONC BLOCK
- 5-CRS 10" CONC BLOCK
- #4 REROD 48" O.C. VERTICAL 2" FROM SOIL
- 1/2"x 12" ANCHOR BOLTS 48" O.C. TO SHARE COMMON FULLY GROUDED CORES MIN EMBEDMENT 7"
- 40-MIL POLYMER-MODIFIED ASPHALT OR 6-MIL POLY FTG TO TOP OF FNDATION WATERPROOFING
- 2X12 TRTD SILL PLATE.
- 10" CLOSED CELL SILL SEALER
- MIN 40 BAR DIA LAP ALL VERT. REINFORCEMENT SPLICES

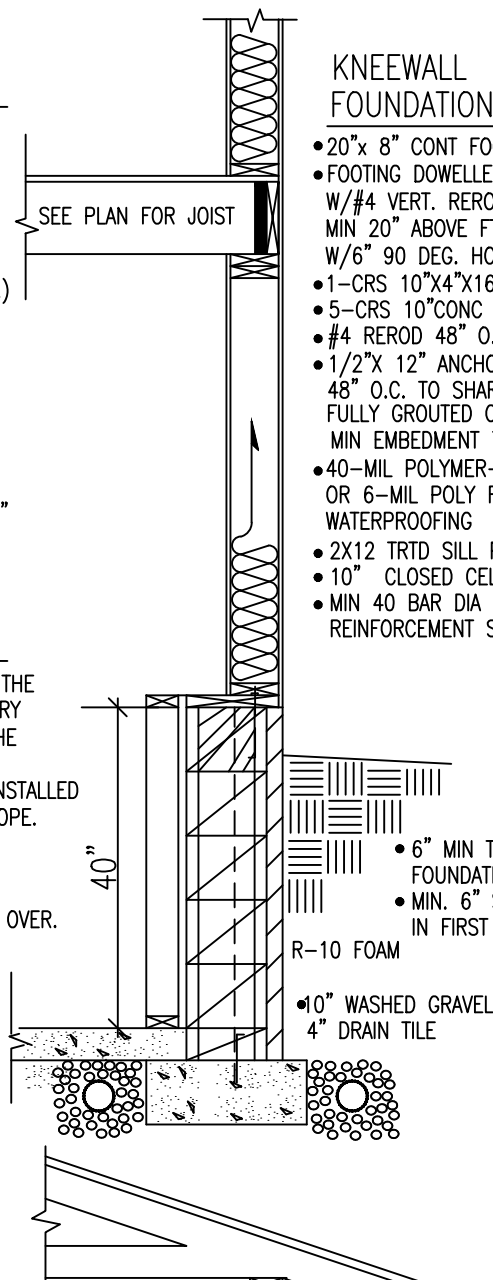

**GARAGE WALL:**

- SIDING NOTED ON PLAN
- TYVEK OR TYPAR HOUSE WRAP
- 7/16" OSB WALL SHEATHING
- 2X4 STUDS 16" O.C.
- 2X4 TRTD BOTTOM PLATE
- 20 MIN. FIRE RATED DR. BETWEEN GARAGE AND HOUSE

**GARAGE FOUNDATION:**

- 18"x8" CONTINUOUS CONC FOOTING
- 4-1/2-CRS 8" CONC BLOCK
- 1-CRS 6"x8"x16" CONC BLOCK
- #4 REROD 48" O.C. VERT 1/2"x 12" ANCHOR BOLTS 48" O.C. TO SHARE COMMON FULLY GROUDED CORES MIN 7" EMBEDMENT
- 2X6 TRTD SILL PLATE
- 6" SILL SEAL
- MIN 40 BAR DIA LAP ALL VERTICAL REINFORCEMENT SPLICES

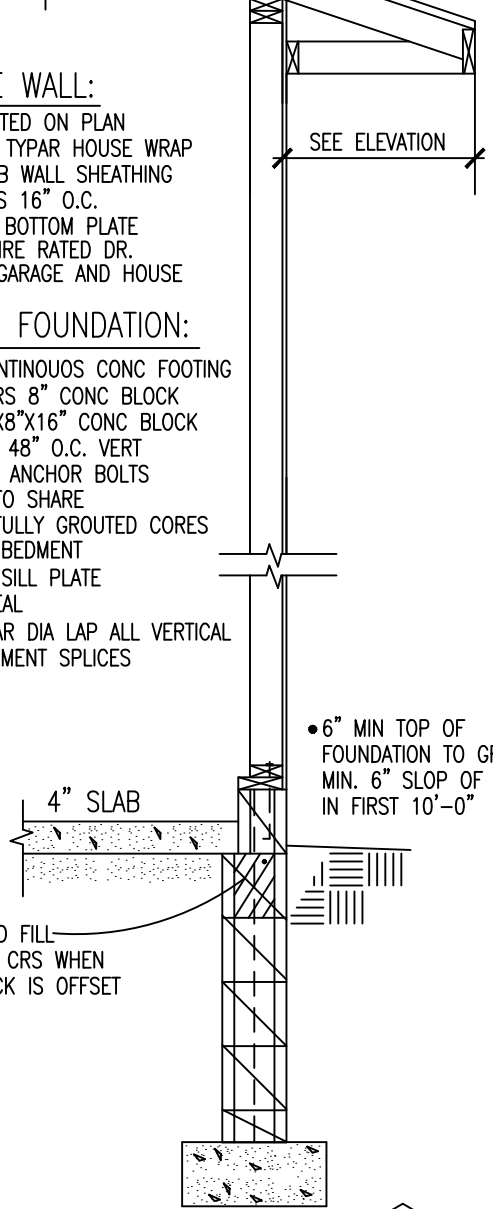

**12 CRS. BSMNT:**

- 20"x 8" CONTINUOUS CONC FOOTING
- 12-CRS 10" CONC BLOCK
- #6 PEROD 48" O.C. VERTICAL .6-3/4" FROM SOIL SIDE FACE OF WALL
- 1/2"x 10" ANCHOR BOLTS 48" O.C. TO SHARE FULLY GROUDED CORES. MIN 7" EMBEDMENT
- 2X12 .40 TRTD SILL PLATE
- 10" CLOSED CELL SILL SEALER
- 40-MIL POLYMER-MODIFIED ASPHALT OR 6 MIL POLY FROM FOOTING TO TOP OF FNDATION.
- WATERPROOFING MIN 40 BAR DIA. LAP ALL VERTICAL REINFORCEMENT.

**PROGRESSIVE PLAN DESIGN LLP**

RESIDENTIAL ARCHITECTURE  
714 County RD. 3 NW Byron MN, 56020  
(507-775-6877) progressiveplandesign@gmail.com

These drawings have been prepared using information provided by the customer/contractor who is solely responsible for the accuracy of the information provided. The drawings are not a substitute for permit drawings prepared by a contractor or architect and may not meet all applicable codes and practices. Before starting construction, the customer should consult a contractor or architect for building codes and practices. The customer is responsible for obtaining all necessary building codes or regulations. The customer is responsible for obtaining all necessary permits to project of project site. Consult local building officials to determine if a building permit is required. We assume no responsibility for claims or damages arising from errors, omissions, deficiencies, improper construction, or defects of the drawings.  
Customer/Contractor Signature \_\_\_\_\_ Date \_\_\_\_\_  
Acknowledged by \_\_\_\_\_

**VALLEY HOME IMPROVEMENT**  
OWNER:  
**BUCKNELL FIRST**  
LOT#1 BLOCK#1

CONTRACTOR:  
**R.H.**  
DATE: \_\_\_\_\_  
SQ. FT. \_\_\_\_\_  
JOB NUM. **2615104**  
SCALE: **NOTED**  
SHEET: \_\_\_\_\_ OF \_\_\_\_\_  
1/4"=1'0" 18x24

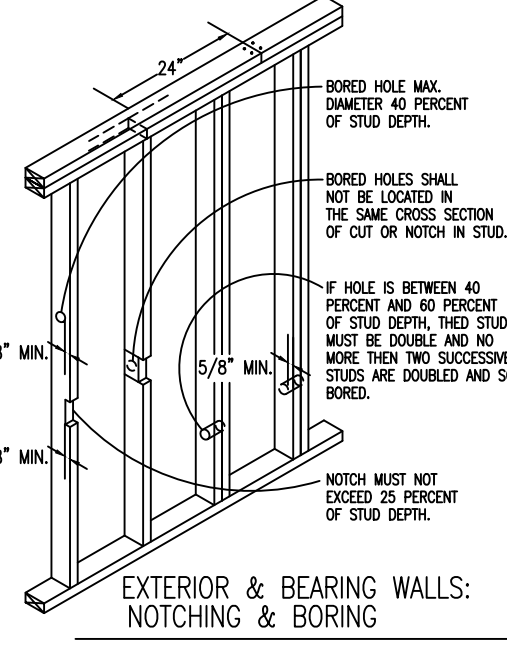

DISCRIPTION: MAIN FLOOR DATE:

BRACED PANEL LENGTH TABLE									
* ADJUSTMENT CALCULATION EXAMPLE									
BRACED WALL LINE	BRACING METHOD TABLE R602.10.4.1	BRACED WALL LINE SPACING	REQUIRED BRACING LENGTH (FEET)	EXPOSURE FACTOR CONDITION	ROOF TO EAVE TOTAL	WALL HEIGHT TOTAL	NUMBER BRACED WALL LINES	REQUIRED BRACING LENGTH (FEET)	PROVIDED BRACING LENGTH
①	CS-WSP	30 FT.	4.5'	1.0	0.94	0.90	1.3	4.9'	11.3'
②	GB	30 FT.	9.5'	1.0	0.94	0.90	1.3	11.0'	22.3'
③	CS-PF	24 FT.	3.9	1.0	0.94	1.0	1.3	4.7'	5.6'

BRACED PANEL LENGTH TABLE									
* ADJUSTMENT CALCULATION EXAMPLE									
BRACED WALL LINE	BRACING METHOD TABLE R602.10.4.1	BRACED WALL LINE SPACING	REQUIRED BRACING LENGTH (FEET)	EXPOSURE FACTOR CONDITION	ROOF TO EAVE TOTAL	WALL HEIGHT TOTAL	NUMBER BRACED WALL LINES	REQUIRED BRACING LENGTH (FEET)	PROVIDED BRACING LENGTH
A	CS-WSP	42 FT.	6.3'	1.0	0.94	0.90	1.45	7.7'	12.0'
B	CS-WSP	32 FT.	4.8'	1.0	0.94	1.0	1.45	6.5'	8.0'
C	CS-WSP	42 FT.	6.3'	1.0	0.94	0.90	1.45	7.7'	12.0'
D	CS-WSP	32 FT.	4.8'	1.0	0.94	1.0	1.45	6.5'	8.0'

DISCRIPTION: LOWER FLOOR DATE:

BRACED PANEL LENGTH TABLE									
* ADJUSTMENT CALCULATION EXAMPLE									
BRACED WALL LINE	BRACING METHOD TABLE R602.10.4.1	BRACED WALL LINE SPACING	REQUIRED BRACING LENGTH (FEET)	EXPOSURE FACTOR CONDITION	ROOF TO EAVE TOTAL	WALL HEIGHT TOTAL	NUMBER BRACED WALL LINES	REQUIRED BRACING LENGTH (FEET)	PROVIDED BRACING LENGTH
①	CS-WSP	10 FT.	3.5	1.0	0.97	0.90	1.0	3.0'	11.8'

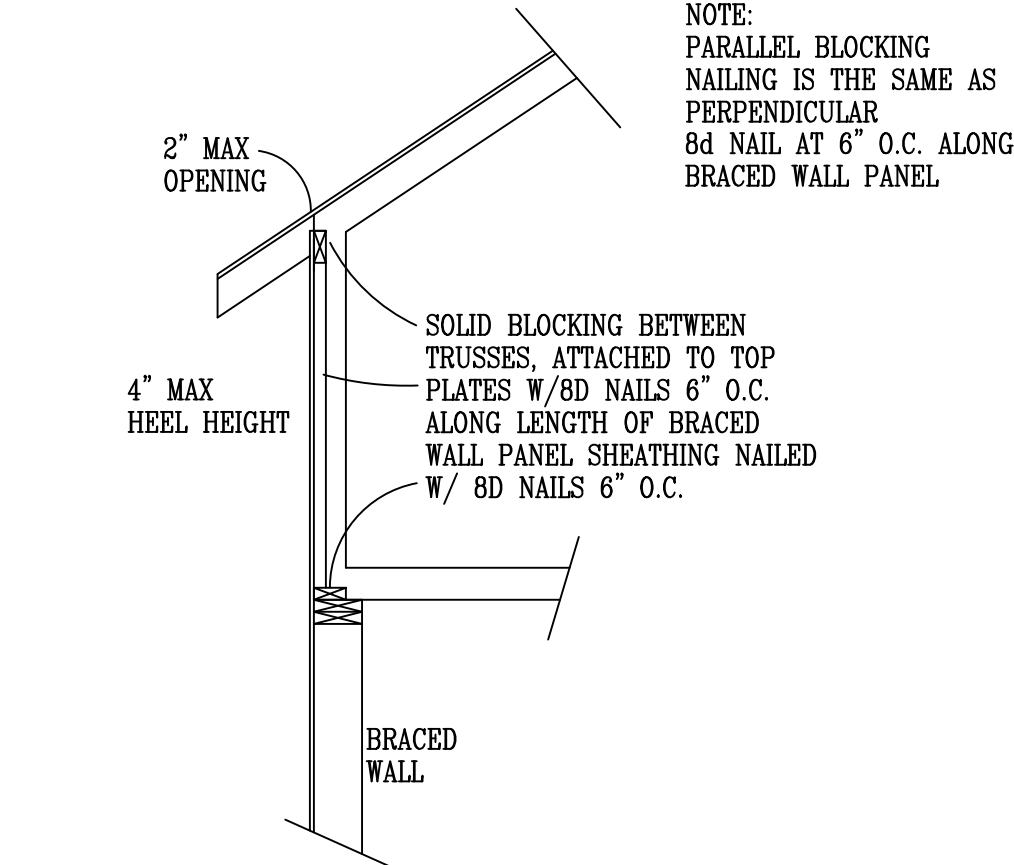
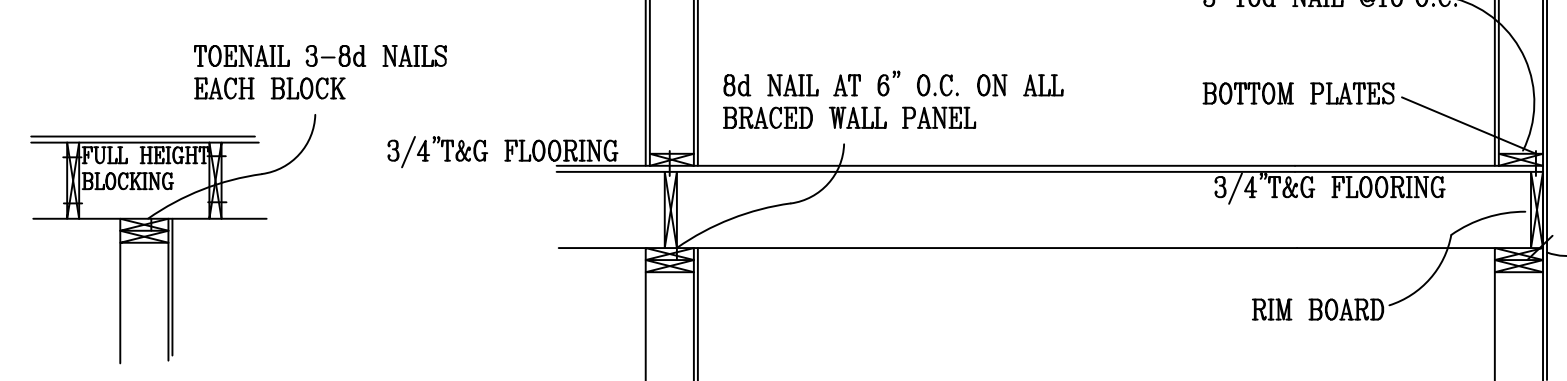
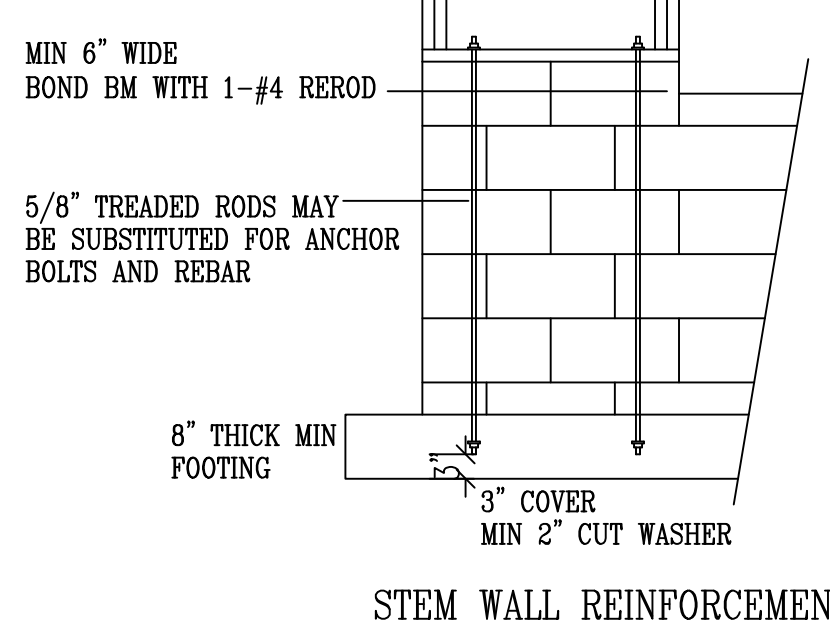
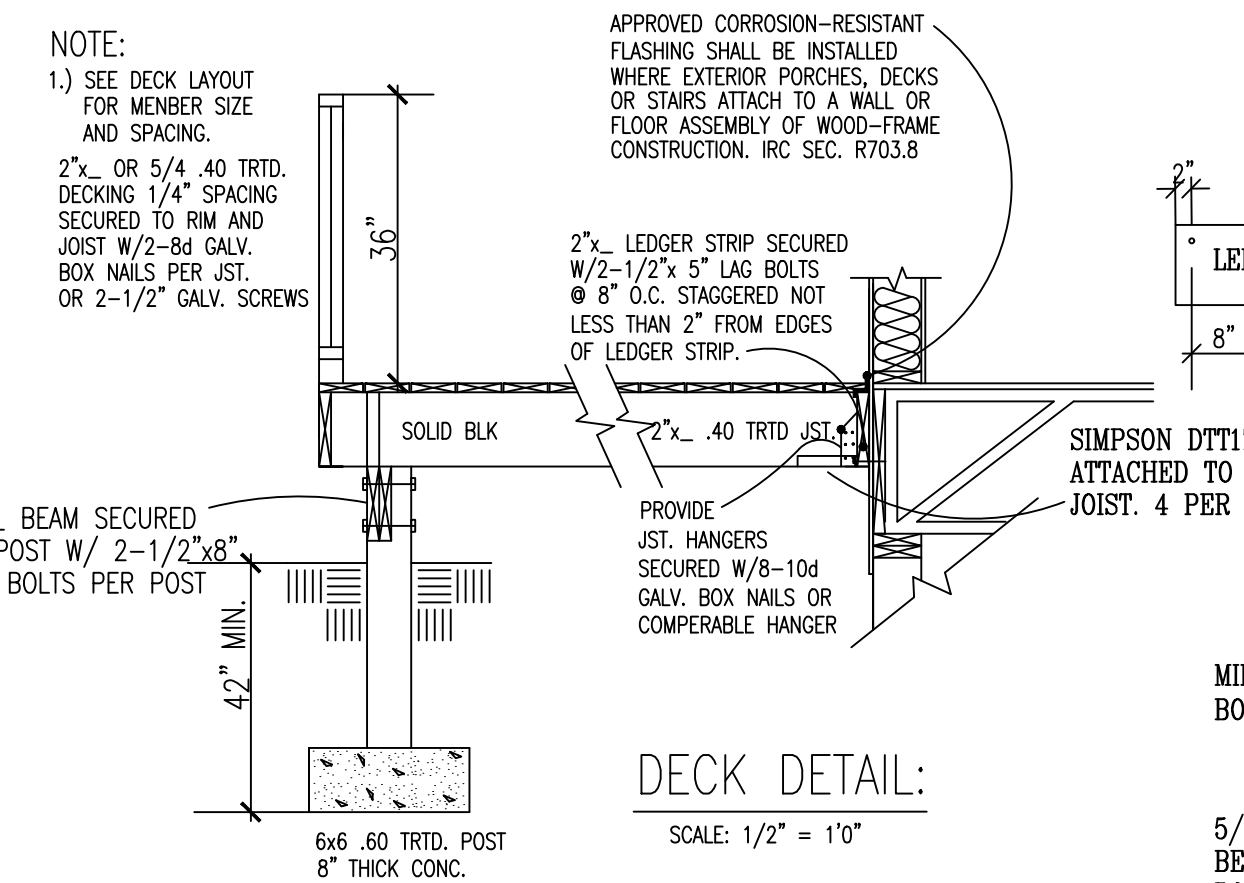

NOTE:  
PARALLEL BLOCKING NAILING IS THE SAME AS PERPENDICULAR  
8d NAIL AT 6" O.C. ALONG BRACED WALL PANEL

GB BRACED WALL PLATE FASTENED TO FLOOR W/ 3-16d NAILS @ 16"O.C. OR FULL HEIGHT BLOCKING 16"O.C. 3-8d NAILS EACH BLOCK. SHEET ROCK SCREWS @ 7" AT EDGES AND IN FIELD.

WALL BRACING NOTES CS-WSP

1. ALL WALLS SHALL BE CONTINUOUSLY SHEATHED WITH WOOD STRUCTURAL PANELS
2. CS-WSP ON PLANS INDICATE AREAS OF BRACED PANELS
3. BRACED PANELS SHALL BE CONSTRUCTED WITH 16" O.C. STUDS. TOP PLATES FASTENED TO SOLID FRAMING WITH 8d NAILS 6" O.C. BOTTOM PLATES FASTENED TO SOLID FRAMING W/ 3-16d NAILS 16"O.C. 7/16" OSB SHEATHING W/ 24/16 INDEX FASTENED W/ 8d COMMON NAILS 6"O.C. ON EDGES AND 12" O.C. IN FIELD. SOLID BLOCKING BETWEEN TRUSSED WITH HEEL GREATER THAN 9-1/4" TO WITHIN 2" OF ROOF SHEATHING FASTENED WITH MIN 8d NAILS 6" O.C. ALONG LENGTH OF PANEL
4. ANY OTHER TYPE OF BRACING METHOD SHALL BE INDICATED ON PLAN AND SEPARATE DETAIL WILL BE PROVIDED.

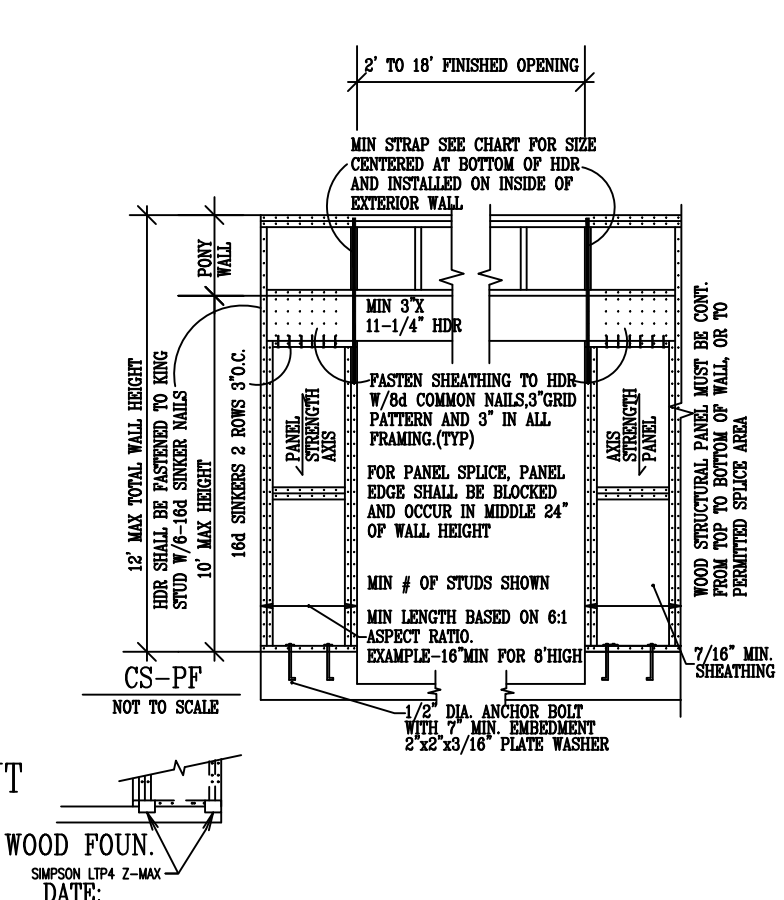

TENSION STRAP CAPACITY FOR WIND PRESSURE REQ. FOR PFH, PFG, AND CS-PF					
MIN WALL STUD FRAMING NOMINAL SIZE AND GRADE	MAXIMUM PONY WALL HEIGHT	MAXIMUM TOTAL WALL HEIGHT	MAXIMUM OPENING WIDTH	TENSION STRAP CAPACITY REQ. 115MPH WIND	
				EXPOSURE B	EXPOSURE C
2X4 NO.2 GRADE	0	10	18	1000	1000
			9	1000	1000
	1	10	16	1025	2500
			18	1275	2850
	2	10	9	1000	1875
			16	2175	4125
	2	12	18	2500	DR
			9	1500	3175
2X6 STUD GRADE	4	12	16	3375	DR
			18	3975	DR
	4	12	9	2750	DR
			12	3775	DR
	2	12	9	1000	2025
			16	2150	3675
4	12	18	2550	DR	
		9	1750	3125	
4	12	16	2400	DR	
		18	3800	DR	

PROGRESSIVE PLAN DESIGN LLP  
RESIDENTIAL ARCHITECTURE  
714 County Rd. 3 NW Byron MN, 56220  
(507-775-6877) progressiveplandesign@gmail.com

These drawings have been prepared using information provided by the customer/contractor who is solely responsible for the accuracy of the information provided. The drawings are not a substitute for permit drawings prepared by a contractor or architect and may not meet all applicable codes and practices. Before starting construction, the customer should consult a contractor or architect for advice on building codes and practices. The customer is responsible for obtaining all necessary building codes or regulations. 2. project structural requirements. 3. existing conditions specific to project site. Consult local building officials to determine if a building permit is required. We assume no responsibility for claims or damages arising from errors, omissions, deficiencies, improper construction, or defects of the drawings.  
Customer/Contractor Signature \_\_\_\_\_ Date \_\_\_\_\_  
Acknowledged by \_\_\_\_\_

CONTRACTOR: VALLEY HOME IMPROVEMENT  
OWNER: BUCKNELL FIRST LOT#1 BLOCK#1

DRAWN BY: R.H.  
DATE:  
SQ. FT.:  
JOB NUM: 2615104  
SCALE: NOTED  
SHEET: OF:  
1/4"=1'0" 18x24

## PURCHASE AGREEMENT

**RECEIVED OF** New Horizon Homes, LLC the sum of \$500.00 as earnest money in part payment for the purchase of property in Mower County, Minnesota, described as:

Lot 10, Block 1, Nature Ridge Third in Outlot D and Outlot E, Nature Ridge and Northeast Quarter of the Southeast Quarter of Section 35, Township 103 North, Range 18 West, Austin, Mower County, Minnesota.

LEGAL TO GOVERN, all of which property the undersigned has this day sold to the buyer for the sum of \$43,900.00, which the buyer agrees to pay as follows: Earnest money \$500.00 and \$43,400.00 cash when the buyer obtains the construction loan but not later than June 1, 2025. Seller will defer \$10,000.00 of the purchase price until the spec home is sold by buyer herein and buyer will sign a Promissory Note for 10,000.00 with no interest to accrue.

The real estate taxes due and payable in the year 2025 shall be prorated as of the date of closing. The real estate taxes due and payable in the year 2026 and thereafter shall be paid by the buyer.

Any special terms, conditions or representations, not readily determined by actual inspection are to appear on the reverse side of this contract.

Subject to performance by the buyer, the seller agrees to execute and deliver a Warranty Deed conveying a marketable title to said premises subject only to the following exceptions: (a) Building regulations, zoning laws, ordinances, state and federal regulations, (b) Restrictions relating to use or improvement of premises not subject to unreleased forfeiture, (c) Reservation of any minerals or mineral rights to the State of Minnesota. Utility Easements. Subject to rights of tenants, if any.

Seller certifies that there are no wells or septic system on said property.

To the best of Sellers knowledge, there are no hazardous substances or underground storage tanks except herein noted: NONE.

Seller is not aware of any methamphetamine production that has occurred on the property.

The seller further agrees to deliver possession not later than June 1, 2025 PROVIDED THAT ALL THE CONDITIONS OF THIS AGREEMENT HAVE BEEN COMPLIED WITH. Closing date shall be on or before June 1, 2025.

The Seller shall at its sole cost and expense provide Buyer with a current Commitment from a title insurer acceptable to Buyer for issuance of an Owner's Title Insurance Policy (the "Title Commitment"). Buyer shall be allowed twenty (20) days after receipt of the Title Commitment for examination and the making of any objections thereto, such objections (exclusive of any of the Permitted Title Exceptions) to be made in writing or deemed to be waived. If any objections are so made, Seller shall be allowed sixty (60) days after receipt of such objections to

make title marketable. If title is not marketable and is not made to within said sixty (60) days of this Agreement, Buyer may either (i) waive the uncured title defect and proceed with this transaction; (ii) terminate this Agreement by written notice to Seller, whereupon the Earnest Money shall be returned to Buyer and the parties shall be relieved of all further liability under this Agreement; (iii) exclude from this Agreement in writing the portions of the Property affected by the uncured title defect and proceed with this Agreement as to the remainder of the Property, with appropriate adjustment in the Purchase Price. If the title to the Property is found marketable or is made so within said time, and this Agreement is terminated by Seller in accordance with Minnesota Statutes Section 559.21, all Earnest Money shall be retained by Seller as liquidated damages.

(1) The following shall be Permitted Title Exceptions:

- (a) Easements of record which do not interfere with the Buyer's intended use of the Property.
- (b) Reservations of minerals or mineral rights by the State of Minnesota.
- (c) Building, zoning and subdivision laws and regulations provided the Property and its current use are in compliance with the same.
- (d) The lien of real estate taxes which are payable by Buyer pursuant to the terms and conditions of this Agreement.

(2) The following shall not be Permitted Encumbrances:

- (a) Any mortgage now of record against the Property.
- (b) Judgments or liens not satisfied at or before Closing.
- (c) Real estate taxes and special assessments which are the responsibility of Seller pursuant to the terms and conditions of this Agreement.

**Buyer has a general willingness to take title subject to the listed Permitted Title Exceptions subject to the other provisions of this Agreement and to an examination of title based upon the Minnesota Title Standards and upon Minnesota law.**

Buyer also reserves the right to evaluate the Permitted Title Exceptions in the light of Buyer's intended uses and enjoyment of the Property. Buyer shall have until the end of the period for stating Title Objections under subparagraph B above to make the evaluation and determine if these title issues will affect Buyer's intended use and enjoyment of the Property. If Buyer, in Buyer's sole discretion, determines that these title issues will adversely affect Buyer's intended use and enjoyment of the Property, Buyer may declare this Purchase Agreement void by timely notice to Seller, neither party shall be liable for damages hereunder to the other, and earnest money shall be refunded to Buyer. If the period for stating Title Objections passes without Buyer's declaring that these title issues will adversely affect Buyer's intended use and enjoyment of the Property, then, subject to Seller's covenant to deliver a good and marketable title of record, Buyer shall take title subject to all Permitted Title Exceptions.

By delivery of the foregoing documents to Purchaser, Seller shall be deemed to have represented that all such documents and information are to Seller's Knowledge true, correct and

complete.

Buyer shall pay for the cost of an Owner's Title Insurance Policy.

I hereby agree to sell/purchase the said property for the price and upon the terms above mentioned, and subject to all conditions herein expressed.

Dated this 23<sup>rd</sup> day of October, 2024.

**NATURE RIDGE PROPERTIES OF  
AUSTIN CO., Seller**

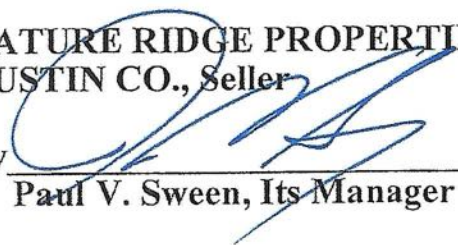
By   
Paul V. Sween, Its Manager

**NEW HORIZON HOMES, LLC,  
Buyer**

By   
Jon Blaine, Its President

**THIS IS A LEGALLY BINDING CONTRACT BETWEEN BUYER AND  
SELLER. IF YOU DESIRE LEGAL OR TAX ADVICE, CONSULT AN  
APPROPRIATE PROFESSIONAL.**

C:\Users\jschumacher\Documents\91226 New Horizon\2024,10.23 91226 PURCHASE AGREEMENT Lot 10, Block 1, Nature Ridge  
3rd.docx

NEW HORIZON HOMES LLC

Vendor Name: NATURE RIDGE PROPERTIES OF AUSTIN CO.

Check Date: 10/24/2024

Total Payment: \$ 500.00

Memo: Earnest Money Lot 10, Block 1, Nature Ridge Third



New Horizon Homes LLC  
25388 670<sup>th</sup> Street  
Kasson MN 55944-1822

EZShield<sup>TM</sup> Check Fraud  
Protection for Business

10-24-24

Pay to the order of:

**NATURE RIDGE PROPERTIES OF AUSTIN CO.**

\$ 500.00

the sum of:

**FIVE HUNDRED AND 00/100**

**DOLLARS**

Memo: **EARNEST MONEY LOT 10, BLOCK 1, NATURE RIDGE THIRD**

**Bremer Bank**  
Bremer.com  
1-800-908-2265

Security features. Details on back.

# HOUSING TAX ABATEMENT APPLICATION

(Application Period 1-1-2023 through 12-31-2025)

Property Owner / Applicant: Bigelow & Lennon Construction, LLC

Current Address: 211 1st St SW, Byron, MN, 55920, USA

Telephone: 507-775-7068

E-Mail: jill@bigelowlennon.com

Has applicant ever defaulted on property taxes? No

*If Yes, provide details on separate page(s).*

Are property taxes current? Yes

PROJECT <i>(check all that apply)</i>	
Single-Family	Multi-family Complex
New Construction	
Is this an application for a replacement of an existing housing unit on the same parcel? No	
Is this application for an existing housing unit you intend to move to this parcel? No	
If YES, where is the unit being relocated from?	
Project Address:	
Project Legal Description: SubdivisionName OAK RIDGE ADDITION Lot 009 Block 003 SubdivisionCd 34523	
Parcel Number: 34.523.0270	Est. Project Valuation: \$ 269,000

**Attach** building plans, site plan, certification from zoning entity that housing project complies with zoning regulations and there are no outstanding land use issues. (Include letter of consent from property owner if subject to purchase agreement or include a copy of the purchase agreement.)

*I / We as applicant(s) for the Housing Tax Abatement submit this application having read the policy and understand the provisions as outlined including, but not limited to, the potential of a partial abatement in year one, due to % of completion on January 2<sup>nd</sup>, there are not any non-compliance or non-conformity outstanding land use issues on the parcel, construction must commence within one year of the approval, assessors cannot be refused access to the property for assessment purposes and the abatement is awarded annually following full payment of real estate taxes due.*

**Bigelow & Lennon Construction, LLC - Applicant submitted via online form and agreed to conditions above  
04/01/2026**

Signature of Applicant(s)

Date

FOR OFFICE USE ONLY:

ELIGIBLE / APPLICABLE APPROVALS

Mower County

Date:

City or  Township of

Date:

School District of

Date:

**Disclaimer:** Each taxing entity makes its own decision on approval or denial of application for tax abatement. Applications must comply with all requirements of the policy/program as outlined in the policy/program guidelines and build within allotted timeframe or tax abatement offer will be automatically terminated.

**Notice - City of Austin Housing Projects** This application must be approved prior to the building permit being issued by the City of Austin.

# PROGRESSIVE PLAN DESIGN LLP

RESIDENTIAL ARCHITECTURE  
714 County Rd 3 NW Byron MN 55920  
(507)775-6677 progressiveplandesign@gmail.com

LOT,9 BLK.3  
SUBDIVISION:OAK RIDGE ADD  
CITY:AUSTIN STATE: MN  
CONTRACTOR:BIGELOW  
CUSTOMER: GARRETT JENKINS



SCALE: 1" = 40'

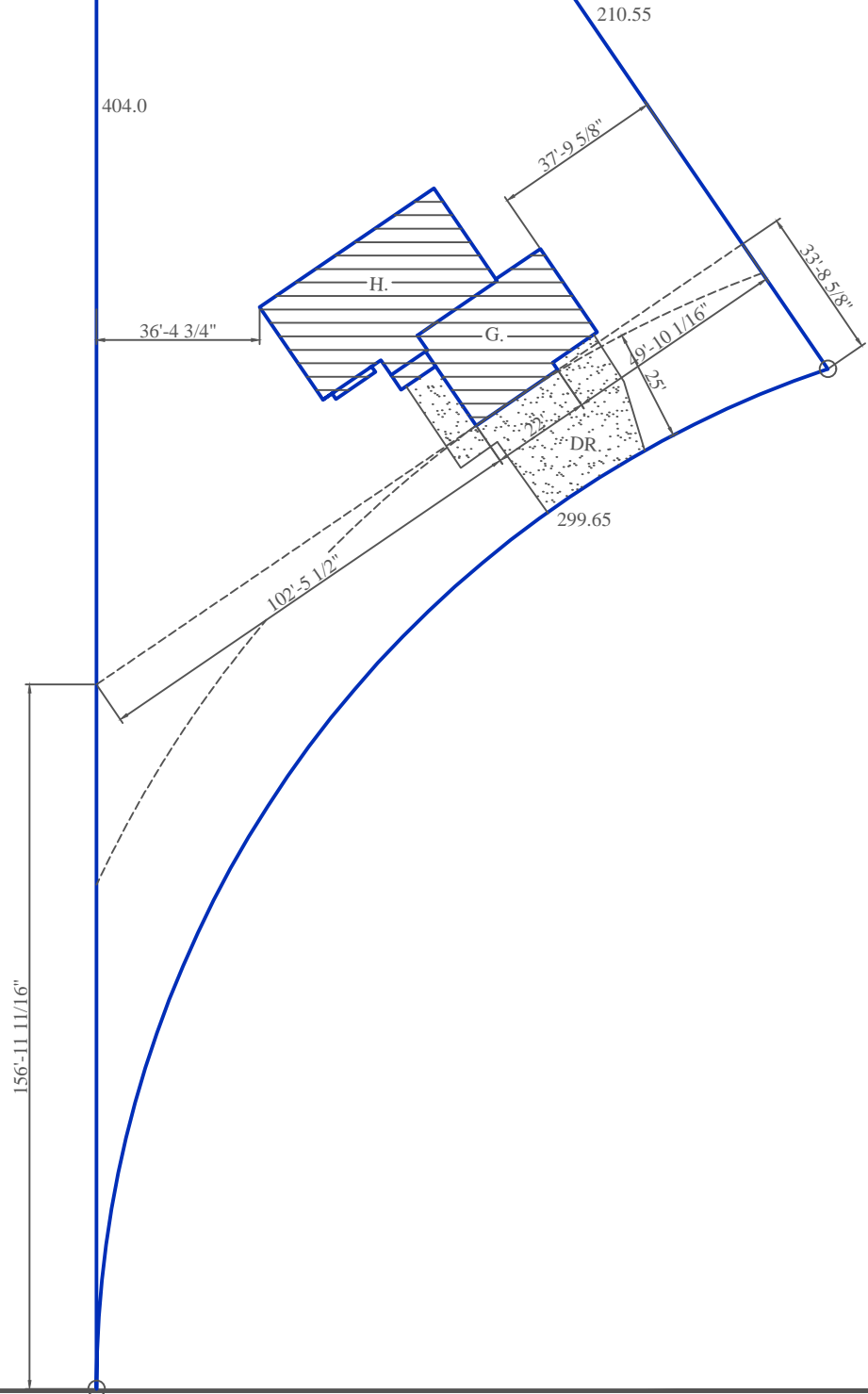



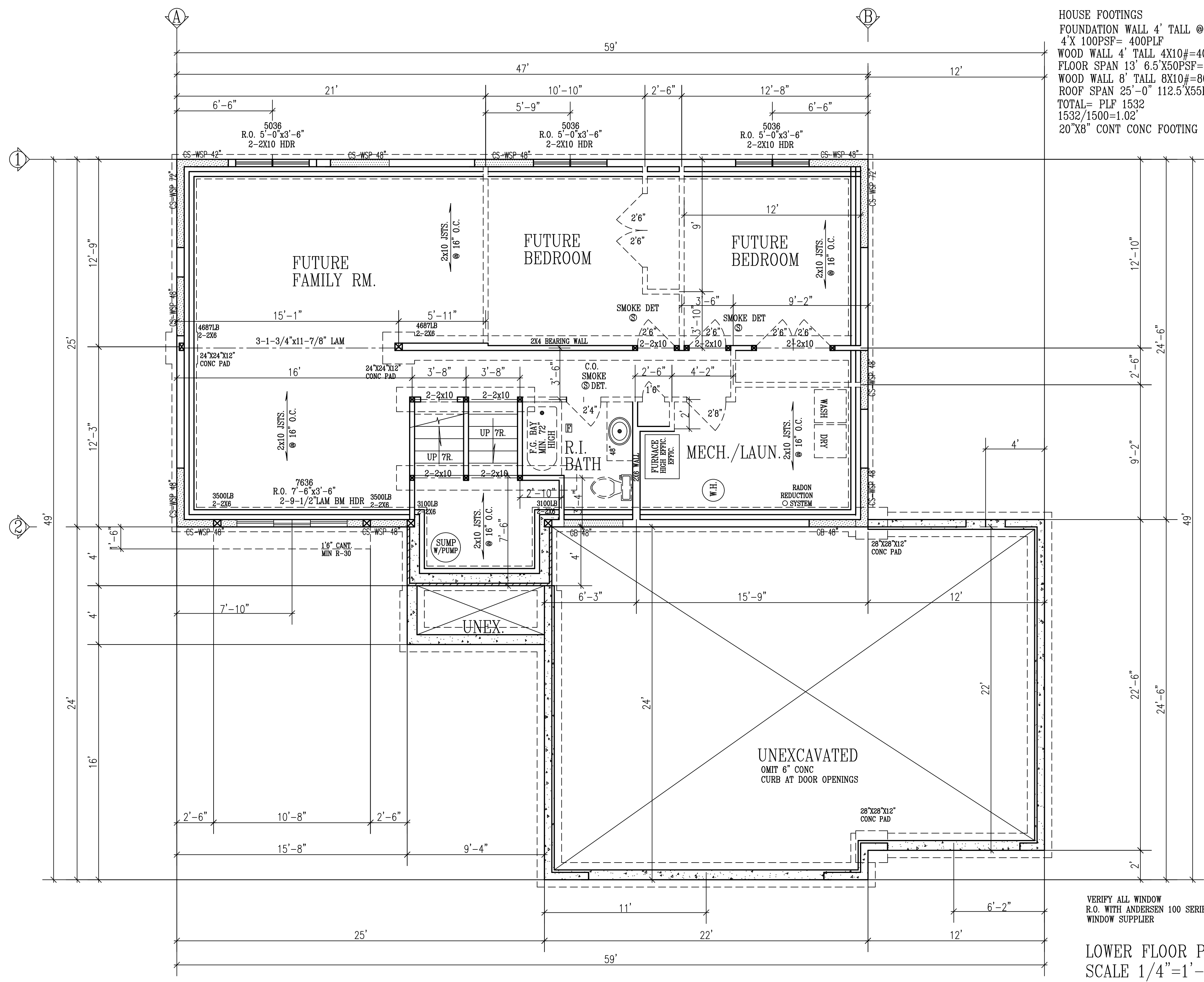

HOUSE FOOTINGS  
 FOUNDATION WALL 4' TALL @ 100#SF  
 4'X 100PSF= 400PLF  
 WOOD WALL 4' TALL 4X10#=40PLF  
 FLOOR SPAN 13' 6.5'X50PSF=325PLF  
 WOOD WALL 8' TALL 8X10#=80PLF  
 ROOF SPAN 25'-0" 112.5'X55PSF=687PLF  
 TOTAL= PLF 1532  
 1532/1500=1.02  
 20"X8" CONT CONC FOOTING

**PROGRESSIVE PLAN  
 DESIGN LLP**  
 RESIDENTIAL ARCHITECTURE  
 714 County RD. 3 NW Byron MN. 56920  
 (507-775-6877) progressiveplandesign@gmail.com

These drawings have been prepared using information provided by the customer/contractor who is solely responsible for the accuracy of the information provided. The drawings are not a substitute for permit drawings prepared by a contractor or architect and may not meet all applicable codes and practices. Before starting construction, the customer should consult a contractor or architect for advice on building codes and practices. The customer should also consult local building codes and regulations. The customer is responsible for obtaining all necessary permits for this project. The customer is responsible for determining if a building permit is required. We assume no responsibility for claims or damages arising from errors, omissions, deficiencies, improper construction, or defects of the drawings.  
 Acknowledged by \_\_\_\_\_ Date \_\_\_\_\_  
 Customer/Contractor Signature

CONTRACTOR:  
 OWNER:  
**GARRETT JENKINS**

VERIFY ALL WINDOW  
 R.O. WITH ANDERSEN 100 SERIES  
 WINDOW SUPPLIER

**LOWER FLOOR PLAN**  
 SCALE 1/4"=1'-0"

DRAWN BY:	R.H.
DATE:	
SQ. FT.	1214
JOB NUM.	2615083
SCALE:	NOTED
SHEET:	OF:
1/4"=1'0" 18x24	



• WOOD FRAMING 2X4, 2X6 STD #2 GRADE OR BETTER UNLESS OTHERWISE NOTED.

- R. WDWS U. .31
- R. .61 STEEL SIDING
- R. .54 7/16" STRUCT. PANEL  
(R. 9.44) 2x6 STUDS  
@ 16" O.C.
- R. 20.00 5-1/2" F.G. INSUL.
- R. .06 6 MIL. POLY V.B.
- R. .45 1/2" GYP. BD.
- R. .85 AIR FILMS
- R. 22.57 TOTAL WALL

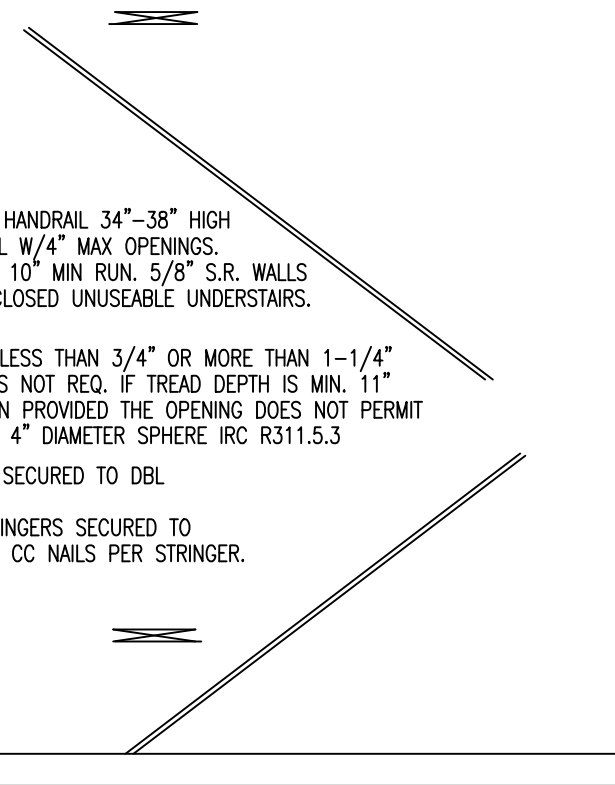
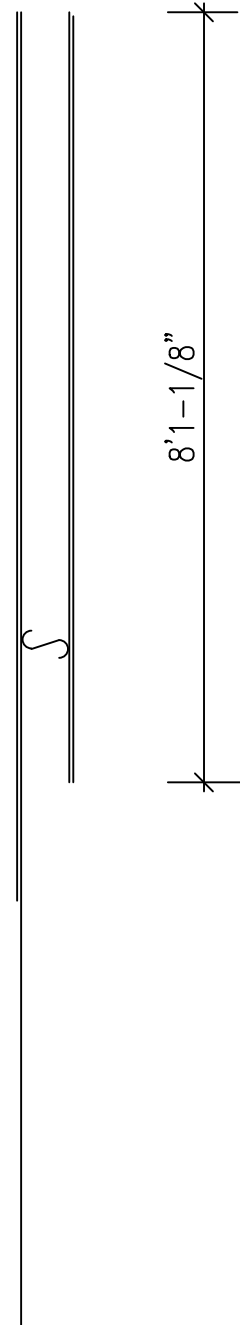

STRINGER. PROVIDE HANDRAIL 34"-38" HIGH  
36" HIGH GUARDRAIL W/4" MAX OPENINGS.  
7-3/4" MAX RISE, 10" MIN RUN. 5/8" S.R. WALLS  
AND SOFFIT OF ENCLOSED UNUSEABLE UNDERSTAIRS.

A NOSING OF NOT LESS THAN 3/4" OR MORE THAN 1-1/4"  
IS REQUIRED AND IS NOT REQ. IF TREAD DEPTH IS MIN. 11"  
RISER MAY BE OPEN PROVIDED THE OPENING DOES NOT PERMIT  
THE PASSAGE OF A 4" DIAMETER SPHERE IRC R311.5.3

1/2" AC PLYWOOD SECURED TO DBL

PER STRINGER, STRINGERS SECURED TO  
PLYWOOD W/4-16d CC NAILS PER STRINGER.

**EMERGENCY ESCAPE WINDOWS:  
AND WINDOW WELL SPECS.**

5 SQ. FT. MIN. 20" WIDE, MIN. 24" HIGH CLEAR OPENING.  
WINDOWS PERMITTED AT GRADE LEVEL. GRADE LEVEL IS  
DEFINED AS THE WINDOW HAVING A SILL HGT. OF NOT MORE  
THAN 44" ABOVE OR BELOW GROUND LEVEL.  
MINNESOTA RULES, 1309.0310, SEC. R310.1  
MIN. CEILING HGT. 36" MAINTAINED ABOVE EXTERIOR GRADE  
FROM EXTERIOR WALL TO PUBLIC WAY (I.E. UNDER DECKS OR CANT.)  
MIN 36" CLEAR SPACE IN FRONT OF WINDOW.

WINDOW WELLS WITH A VERTICAL DEPTH GREATER THAN 44"  
BELOW THE ADJACENT GROUND LEVEL SHALL BE EQUIPPED WITH  
A PERMANENTLY AFFIXED LADDER OR STEPS USABLE WITH THE  
WINDOW IN THE FULLY OPEN POSITION.  
THE LADDER OR STAIRS SHALL BE PERMITTED TO ENCROACH A  
MAXIMUM OF 6 INCHES.

LADDERS OR RUNGS SHALL HAVE AN INSIDE WIDTH OF AT LEAST 12"  
AND SHALL PROJECT AT LEAST 3" FROM THE WALL AND SHALL BE  
SPACED NOT MORE THAN 18" ON CENTER VERTICALLY FOR THE  
FULL HEIGHT OF THE WINDOW WELL.

**FLASHING & COUNTERFLASHING**

APPROVED CORROSION-RESISTIVE FLASHING SHALL BE PROVIDED IN THE  
EXTERIOR WALL ENVELOPE IN SUCH A MANNER AS TO PREVENT ENTRY  
OF WATER INTO THE WALL CAVITY OR PENETRATION OF WATER TO THE  
BUILDING STRUCTURAL FRAMING COMPONENTS. THE FLASHING SHALL  
EXTEND TO THE SURFACE OF THE EXTERIOR WALL FINISH AND BE INSTALLED  
TO PREVENT WATER FROM RE-ENTERING THE EXTERIOR WALL ENVELOPE.  
FLASHING SHALL BE INSTALLED CONTINUOUSLY ABOVE ALL  
PROJECTING WOOD TRIM.

FLASHING SHALL BE INSTALLED AT WALL AND ROOF INTERSECTIONS.  
EXTEND DRIP CAPS PAST THE END OF THE BRICK MOLD AND BEND OVER.  
INSTALL KICK OUT FLASHING WHERE STEP FLASHING BEGINS.

WITH EITHER A CONT. CRS OF SOLID MASONRY, OR 1 C

OF THE WALL INTO LIVING SPACE. WHERE BRICK LEDGE IS  
INSTALLED, THE CRS IMMEDIATELY BELOW THAT LEDGE SHALL BE  
SEALED. JOINTS, CRACKS, OR OTHER OPENINGS AROUND  
PENETRATIONS OF BOTH EXTERIOR AND INTERIOR SURFACES  
OF MASONRY WALL, WOOD FOUNDATION WALLS BELOW GRADE  
SURFACE SHALL BE FILLED WITH POLYURETHANE CAULK  
MIN 3" ABS,PVC,OR EQUIVALENT GASTIGHT PIPE SHALL BE  
INSERTED INTO INTERIOR PERIMETER DRAIN AND 15" ON CENTER  
TILE LOOP OR THROUGH A SEALED SUMP COVER, WHERE THE  
SUMP THE SUMP IS EXPOSED TO THE SUB-SLAB SAND  
RADON VENTS SHALL CONNECT TO SINGLE PIPE THAT  
TERMINATES AT LEAST 12" ABOVE ROOF.  
RADON PIPES SHALL PROVIDE ENOUGH SPACE AROUND PIPE  
FOR REQUIRED FAN, MIN 24" DIA. CENTERED ON AXIS OF VENT STACK  
A MIN VERTICAL DISTANCE OF 36"  
RADON PIPES SHALL BE IDENTIFIED WITH ONE LABEL ON  
EACH FLOOR, LABEL SHALL READ(RADON REDUCTION SYSTEM)

**PROGRESSIVE PLAN  
DESIGN LLP**

RESIDENTIAL ARCHITECTURE  
714 County RD. 3 NW Byron MN, 56920  
(507-775-6877) progressiveplandesign@gmail.com

These drawings have been prepared using information provided by the customer/contractor who is solely responsible for the accuracy of the information provided. The drawings are not a substitute for permit drawings prepared by a contractor or architect and may not meet applicable building codes or regulations. It is the responsibility of the contractor and local codes and practices. Before starting construction, the customer should consult a contractor or architect to determine if the drawings meet applicable building codes and regulations. 2. project structural requirements. 3. existing conditions specific to project or project site. Consult local building officials to determine if a building permit is required. We assume no responsibility for claims or damages arising from errors, omissions, deficiencies, improper construction, or defects of the drawings.  
Acknowledged by \_\_\_\_\_ Customer/Contractor Signature \_\_\_\_\_ Date \_\_\_\_\_

CONTRACTOR:

OWNER:

DRAWN BY:  
R.H.

DATE:

SQ. FT.

JOB NUM.

SCALE:

NOTED

SHEET:

OF:

1/4"=1'0" 18x24



**OFFICIAL MINUTES: AUSTIN SCHOOL BOARD**

**REGULAR MEETING**

Independent School District No. 492

**Monday, April 13, 2026 5:30 pm**

Annex Recital Hall

205 4th Street NW, Austin, Minnesota

**MEMBERS PRESENT:** Cece Kroc Peggy Young  
Don Leathers Daniel Zielke  
Carol McAlister Superintendent Dr. Joey Page

**MEMBERS ABSENT:** Carolyn Dube and Robert Hartman

**MEETING CALLED**

**TO ORDER:** Vice-chairperson Young called the meeting to order at 5:30 p.m. in the Annex Recital Hall.

**AGENDA APPROVED:** A motion was made by Leathers, seconded by McAlister and carried unanimously to approve the agenda as presented.

**PUBLIC HEARING:** A public hearing was held on the proposed property tax abatement for parking lots. No community members addressed the board.

**ACTIVITES DEPARTMENT**

**UPDATES:** Activities Director Katie Carter introduced the winter sport athletes who shared highlights of their winter season. Katie also shared information about the summer strength and conditioning program with ETS and provided highlights of the new girls flag football program which currently has 63 registered participants.

**SUPERINTENDENT'S**

**REPORT:** Superintendent Page shared information about the increase in the AHS graduation rate, recognized several students and staff for their recent achievements, and provided an overview of the many events happening throughout the district.

**SCHOOL BOARD**

**REPORTS:** McAlister and Leathers shared highlights of events they have participated in throughout the last month.

**MINUTES APPROVED:** Zielke made a motion, seconded by McAlister and carried unanimously to approve the regular meeting minutes of 3/9/26 and study session minutes of 3/23/26 as printed.

(A COMPLETE COPY OF THE MINUTES IS ATTACHED IN THE OFFICIAL MINUTE BOOK AND POSTED ON THE DISTRICT WEBSITE.)

**PERSONNEL REPORT**

**APPROVED:** Zielke made a motion, seconded by McAlister and carried unanimously to approve the following personnel items.

Contracts for Approval – Christina Alves, SPED para, effective 3/30/26; Madyson Duenes, COTA, effective 8/10/26; Karen Erickson, psychologist, effective 8/10/26; Christopher Moore, custodian, effective 3/16/26; Margaret Sabharwal, SPED teacher, effective 8/10/26; and Kimberly Sherva, security PARA, effective 4/7/26

Transfers/Contract Modifications – Ngoc Bui, 3.5 hrs/day food service helper to 5 hrs/day, effective 3/2/26 and Deanna Culbert, food service helper moved from AHS to Ellis, effective 3/17/26

Resignations/Retirements – Hyrum Blake, MHP, effective 5/28/26; Connie Christiansen, effective 4/30/26; Jeanne Goodew, SPED teacher, effective 5/28/26; Gage Johnson, noon supervisor, effective 2/23/26; Jacob Nelson, head varsity wrestling coach, effective 3/18/26; Christopher Tobar, SPED para, effective 2/12/26; and Theresa Vokoun, Kids Korner site lead, effective 3/27/26

(A COMPLETE COPY OF THE PERSONNEL REPORT IS ATTACHED IN THE OFFICIAL MINUTE BOOK.)

**BILLS APPROVED:**

Zielke made a motion, seconded by McAlister and carried unanimously to approve the bills for payment as of 4/13/26.

(A COPY OF THE BILLS IS ATTACHED IN THE OFFICIAL MINUTE BOOK.)

**TREASURER'S REPORT APPROVED:**

A motion was made by Zielke, seconded by McAlister and carried unanimously to approve the February 2026 treasurer's report.

(A COPY OF THE TREASURER'S REPORT IS ATTACHED IN THE OFFICIAL MINUTE BOOK.)

**SINGLE AUDIT REPORT APPROVED:**

Zielke made a motion, seconded by McAlister and carried unanimously to approve the FY2025 single audit report. The report was delayed from full audit report due to recent government shut down.

**REVISED POLICIES APPROVED:**

Zielke made a motion, seconded by McAlister and carried unanimously to approve the following revised policies:

410 – Family and Medical Leave

515 – Protection and Privacy of Pupil Records

530 – Immunizations

615 – Testing Accommodations, Modifications, and Exemptions for IEPs, Section 504 Plans, and LEP Students

701 – Establishment and Adoption of School District Budget

and the following new policy:

625 – Responsible Use of Artificial Intelligence

**REPORTS:**

Department/school updates from Superintendent Cabinet members and principals were available for review.

**OFFICIAL MINUTES: AUSTIN SCHOOL BOARD****REGULAR MEETING**

**APEF OVERVIEW:** Austin Public Education Foundation (APEF) Executive Director Tim Ruzek provided an overview of the work being done by the APEF.

**BARR UPDATE:** Building Assets, Reducing Risks (BARR) coordinators Angie Taylor and Karen Dunbar along with Principals Dewey Schara and Dr. Jessica Cabeen provided an overview the BARR program operating at IJ Holton, Ellis and AHS and the positive impact it's having on students especially in the area of behavior referrals, failure rates, and credit attainment.

**TAX ABATEMENT AND  
BOND AUTHORIZATION  
APPROVED:**

A motion was made by Kroc, seconded by Zielke and carried unanimously to approve the resolution calling for the sale of general obligation facilities maintenance and tax abatement bonds.

(A COMPLETE COPY OF THE RESOLUTION IS ATTACHED IN THE OFFICIAL MINUTE BOOK.)

**TRACK RESURFACING  
BID APPROVED:**

Leathers made a motion, seconded by McAlister and carried unanimously to award the bid for Wescott track resurfacing to Ulland Brothers. The approved bid was \$1,514,840 and will be funded out of the long-term facilities maintenance plan and the assigned funds for Wescott Athletic Complex.

**DONATIONS:** A motion was made by Kroc, seconded by Zielke and carried unanimously to approve the donations as presented by Executive Director of Finance and Operations Todd Lechtenberg.

(A COMPLETE COPY OF DONATIONS IS ATTACHED IN THE OFFICIAL MINUTE BOOK.)

**NON-RENEWAL OF  
FOUR PROBATIONARY  
TEACHER CONTRACTS:**

Kroc made a motion, seconded by Zielke and carried unanimously to approve the resolution regarding the termination and non-renewal of the following four probationary teaching contracts:

Samantha Geving, Early Childhood preschool teacher at Community Learning Center;  
Ryan Flanders, Packer Profile teacher at Austin High School;  
Samuel Good, Special Education teacher at Banfield Elementary; and  
Candice Haugen, Special Education teacher at Banfield Elementary.

These termination/non-renewals are effective May 28, 2026.

**BUDGET REDUCTION PLAN  
APPROVED:**

Following a report on the enrollment and Minnesota legislative projections, a review of the proposed FY27 reductions totaling \$4,185,224 was presented. A motion was made by McAlister, seconded by Kroc and carried unanimously to approve the FY27 budget reduction plan as presented.

(A COPY OF PLAN IS ATTACHED IN THE OFFICIAL MINUTE BOOK.)

**OFFICIAL MINUTES: AUSTIN SCHOOL BOARD****REGULAR MEETING**

- DELEGATIONS:** Rhonda Alberts, Phil Burkart, Judi Bjorndal, Nicole Christianson, Emily Wakefield, Tieler Myers, Hiedy Morey, Sophia Meyer and Allison Tobak addressed the board regarding their concerns on the discontinuance of the French program, a change to the music teachers' lesson schedule, and electives.
- MEETING REMINDER:** Vice-chair Young reminded School Board members of the study session scheduled for Monday, April 27, at 4 pm in the District Office Conference Room.
- BOARD ENTERS CLOSED SESSION:** Leathers made a motion, seconded by McAlister and carried unanimously to enter closed session at 9:03 pm for the purpose of Austin Principals Association negotiations strategy. Five board members, HR Director Sue Stark, Exec Dir of Academics and Administrative Services Dr. Katie Baskin, Exec Dir of Finance and Operations Todd Lechtenberg, Superintendent Dr. Joey Page, and School Board secretary Sharon Alms were present for the closed session.
- BOARD ENTERS OPEN SESSION:** Zielke made a motion, seconded by Kroc and carried unanimously to enter open session at 9:19 pm.
- MEETING ADJOURNED:** A motion was made by Zielke, seconded by McAlister and carried unanimously to adjourn the meeting at 9:19 pm.

---

Daniel Zielke, Clerk

**OFFICIAL MINUTES: AUSTIN SCHOOL BOARD**

**STUDY SESSION**

Independent School District No. 492

**Monday, April 27, 2026 4:00 pm**

District Office Conference Room

401 Third Avenue NW, Austin, MN

<b>MEMBERS PRESENT:</b>	Carolyn Dube	Carol McAlister
	Robert Hartman	Peggy Young via TEAMS
	Cece Kroc	Dan Zielke
	Don Leathers (4:05 pm)	Superintendent Dr. Joey Page

**MEMBERS ABSENT:** None

**MEETING CALLED**

**TO ORDER:** Chairperson Dube called the meeting to order at 4:00 p.m. in the District Office Conference Room at Austin High School.

**AGENDA APPROVED:** A motion was made by Hartman, seconded by McAlister and carried unanimously to approve the agenda as presented.

**PROPOSED FACILITIES**

**SCHEDULING TOOL**

**OVERVIEW:**

Committee Chairperson Jen Lawhead presented information on the facilities scheduling tool being recommended for approval. Following demonstrations from several scheduling companies, the committee is recommending contracting with Arux due to the added features required by Community Education, ease of use, and its compatibility with software used by the Big 9. The request for approval will be brought forward at the regular May meeting.

**FACILITIES DISCUSSION**

**AND PLANNING:**

Sue Peterson and Kevin Bills from ISG and Michael Hart from PTMA reviewed identified priority 1 and priority 2 building improvement needs along with potential voter-approved bond and tax impacts. Discussion followed. The board will review the information provided, talk with community members for feedback, and determine if they will conduct a referendum campaign this November at the May special meeting.

**DISTRICT PROGRAMMING**

**AND STAFFING UPDATE:**

Board members took turns sharing their thoughts on proposed budget cuts, how those decisions are made, and the importance of communication.

**ADJOURNMENT:**

A motion was made by Hartman, seconded by Zielke, and carried unanimously to adjourn at 6:36 pm.

\_\_\_\_\_  
Daniel Zielke, Clerk



# AUSTIN PUBLIC SCHOOLS

INSPIRE • EMPOWER • ACCELERATE

For consideration at the May 11, 2026 School Board Meeting:

## New Hires:

Name	Position	Location	Effective Date
Braaten, Jenna	Teacher-Elementary Ed	Holton	8/10/2026
Brumbaugh, Benjamin	Speech Language Pathologist	Southgate	8/10/2026
Harrer, Abby	Teacher-Summer School	ALC/AHS	6/1/2026-7/31/2026
Holdsworth, Elen	Kids Korner Aide	CLC	5/18/2026
Holtz, Kate	Teacher-Elementary Ed	Holton	8/10/2026
Keesey, Madison	Noon Supervisor	Ellis	4/17/2026
Loken, Nicole	Teacher-Summer School	Sumner	6/1/2026-7/31/2026
Louters, Jill	Teacher-Summer School	Sumner	6/1/2026-7/31/2026
Page, Kara	Teacher-Elementary Art	Holton	8/10/2026
Ramirez Garcia, Jennifer	Teacher-Elementary Ed	Holton	8/10/2026
Rasmussen, Caleb	Noon Supervisor	Holton	4/13/2026
Schafer, Kearah	Food Service Helper	AHS	4/2/2026

## Resignations/Retirements:

Name	Position	Location	Effective Date
Christianson, Connie	Para-SPED	Neveln	4/30/2026
Duop, Mission	Para-SPED	Southgate	5/15/2026
Kaplan, Ashley	T&L Coordinator	District	5/26/2026
King, Taylor	Para-SPED	COOP	4/24/2026
Hamlin, Harley	Noon Supervisor	Ellis	4/1/2026
Mensink, Skylee	ECFE Assistant	CLC	4/23/2026
Mix, Olivia	Noon Supervisor	Ellis	4/7/2026
St. Catherine, Clare	Psychologist	Banfield/COOP	5/28/2026
Vierkandt, Karleen	Para-SPED	Southgate	5/28/2026
Wilson, Natalie	ECFE Assistant	CLC	4/23/2026

## Terminations:

Name	Position	Location	Effective Date
Hillman, Karen	Para-SPED	Holton	4/13/2026
Howe, Diana	MHP	Banfield	4/22/2026

**CHECKS ISSUED: 4/27/2026 - 5/11/2026**  
**FOR APPROVAL BY THE SCHOOL BOARD ON MONDAY, May 11, 2026.**

CONTACT TODD LECHTENBERG WITH QUESTIONS:

TELEPHONE: (507) 460-1913

E-MAIL: TODD.LECHTENBERG@AUSTIN.K12.MN.US

Accounts Payable Overview

<i>Date</i>	<i>Batch</i>	<i>Check</i>	<i>Commerce Bank</i>	<i>Wire</i>	<i>P Card</i>	<i>Total</i>
4/22/2026	W261006			\$8,314.00		\$8,314.00
4/24/2026	4/24/26 PR AP	\$24,784.20		\$593,889.11		\$618,673.31
4/27/2026	4/27/26 MPL 1ST QRT, 4/27/26 AFLAC			\$104,261.44		\$104,261.44
4/28/2026	T261004, CB261004	\$581,685.39	\$22,105.26			\$603,790.65
4/29/2026	4/29/26 VOID CK #60613	-\$1,962.24				-\$1,962.24
5/1/2026	5/1/26 PR AP LI, 5/1/26 TRA PERA			\$318,584.68		\$318,584.68
5/4/2026	W261101			\$1,346.16		\$1,346.16
5/5/2026	CB261101, T261101, VRT261101	\$413,762.97		\$10,334.91		\$424,097.88
					<b>TOTAL</b>	<b>\$2,077,105.88</b>

<i>Payroll Summary</i>	
<i>Date</i>	<i>Total</i>
4/9/2026	\$1,304,253.07
4/10/2026	\$3,429.11
4/23/2026	\$1,308,657.32
<b>TOTAL</b>	<b>\$2,616,339.50</b>

<i>Health &amp; Dental Fees &amp; Claims</i>		
	<i>Health</i>	<i>Dental</i>
Week 1	\$282,430.35	
Week 2	\$274,327.57	\$9,405.09
Week 3	\$390,314.37	\$6,629.09
Week 4	\$571,087.25	\$8,742.62
Week 5	\$827.65	\$9,058.87
<b>TOTAL</b>	<b>\$1,518,987.19</b>	<b>\$33,835.67</b>
<b>TOTAL</b>	<b>\$1,552,822.86</b>	

**GRAND TOTAL      \$6,246,268.24**

## Board Packet

AP Run: 4/27/2026 MPL 1st Qrt — Post Date: 2026-04-27 — AP Run Type: R

Austin Public Schools ISD 492

Check Date	Check Number	Payment Type	Name	Check Amount	
04/27/2026	202003794	Wire Transfer	MN DEPT OF ECONOMIC SECURITY	103,606.20	
Invoice Number	Description	Invoice Date	Invoice Amount	Account	Amount
MNPL.01152026.B	MNPL - MN Paid Leave for 1/15/2026 Reg PR	01/15/2026	8,367.11		
		PAID FAMILY LEAVE-MN		01 L 215 19	8,019.60
		PAID FAMILY LEAVE-MN		02 L 215 19	93.64
		PAID FAMILY LEAVE-MN		04 L 215 19	234.04
		PAID FAMILY LEAVE-MN		05 L 215 19	19.83
MNPL.01152026.D	MNPL - MNPL for 1/15/2026 Reg PR	01/15/2026	8,367.11		
		PAID FAMILY LEAVE-MN		01 L 215 19	8,019.60
		PAID FAMILY LEAVE-MN		02 L 215 19	93.64
		PAID FAMILY LEAVE-MN		04 L 215 19	234.04
		PAID FAMILY LEAVE-MN		05 L 215 19	19.83
MNPL.01292026.B	MNPL - MN Paid Leave for 1/29/2026 Reg PR	01/29/2026	8,729.15		
		PAID FAMILY LEAVE-MN		01 L 215 19	8,120.28
		PAID FAMILY LEAVE-MN		02 L 215 19	254.67
		PAID FAMILY LEAVE-MN		04 L 215 19	333.27
		PAID FAMILY LEAVE-MN		05 L 215 19	19.83
		PAYROLL W/HOLDINGS-MN PAID LEAVE		11 L 215 19	1.10
MNPL.01292026.B.a	MNPL - MN Paid Leave for 1/29/2026 GH	01/29/2026	-26.07		
		PAID FAMILY LEAVE-MN		01 L 215 19	-26.07
MNPL.01292026.B.b	MNPL - MN Paid Leave for 1/29/2026 GH RI	01/29/2026	7.14		
		PAID FAMILY LEAVE-MN		01 L 215 19	7.14
MNPL.01292026.D	MNPL - MNPL for 1/29/2026 Reg PR	01/29/2026	8,729.15		
		PAID FAMILY LEAVE-MN		01 L 215 19	8,120.28
		PAID FAMILY LEAVE-MN		02 L 215 19	254.67
		PAID FAMILY LEAVE-MN		04 L 215 19	333.27
		PAID FAMILY LEAVE-MN		05 L 215 19	19.83
		PAYROLL W/HOLDINGS-MN PAID LEAVE		11 L 215 19	1.10
MNPL.01292026.D.a	MNPL - MNPL for 1/29/2026 GH	01/29/2026	-26.07		
		PAID FAMILY LEAVE-MN		01 L 215 19	-26.07

## Board Packet

AP Run: 4/27/2026 MPL 1st Qrt — Post Date: 2026-04-27 — AP Run Type: R

Austin Public Schools ISD 492

Check Date	Check Number	Payment Type	Name	Check Amount	
04/27/2026	202003794	Wire Transfer	MN DEPT OF ECONOMIC SECURITY	103,606.20	
Invoice Number	Description	Invoice Date	Invoice Amount	Account	Amount
MNPL.01292026.D.b	MNPL - MNPL for 1/29/2026 GH RI	01/29/2026	7.14		
				PAID FAMILY LEAVE-MN 01 L 215 19	7.14
MNPL.02122026.B	MNPL - MN Paid Leave for 2/12/2026 Reg PR	02/12/2026	8,612.50		
				PAID FAMILY LEAVE-MN 01 L 215 19	8,072.09
				PAID FAMILY LEAVE-MN 02 L 215 19	232.70
				PAID FAMILY LEAVE-MN 04 L 215 19	287.57
				PAID FAMILY LEAVE-MN 05 L 215 19	19.88
				PAYROLL W/HOLDINGS-MN PAID LEAVE 11 L 215 19	0.26
MNPL.02122026.B.a	MNPL - MN Paid Leave for 2/12/2026 TE	02/12/2026	4.11		
				PAID FAMILY LEAVE-MN 01 L 215 19	4.11
MNPL.02122026.D	MNPL - MNPL for 2/12/2026 Reg PR	02/12/2026	8,612.50		
				PAID FAMILY LEAVE-MN 01 L 215 19	8,072.09
				PAID FAMILY LEAVE-MN 02 L 215 19	232.70
				PAID FAMILY LEAVE-MN 04 L 215 19	287.57
				PAID FAMILY LEAVE-MN 05 L 215 19	19.88
				PAYROLL W/HOLDINGS-MN PAID LEAVE 11 L 215 19	0.26
MNPL.02122026.D.a	MNPL - MNPL for 2/12/2026 TE	02/12/2026	4.11		
				PAID FAMILY LEAVE-MN 01 L 215 19	4.11
MNPL.02262026.B	MNPL - MN Paid Leave for 2/26/2026 Reg PR	02/26/2026	8,675.18		
				PAID FAMILY LEAVE-MN 01 L 215 19	8,074.16
				PAID FAMILY LEAVE-MN 02 L 215 19	255.95
				PAID FAMILY LEAVE-MN 04 L 215 19	301.68
				PAID FAMILY LEAVE-MN 05 L 215 19	19.83
				PAYROLL W/HOLDINGS-MN PAID LEAVE 11 L 215 19	1.56
				PAYROLL W/HOLDINGS-MN PAID LEAVE 12 L 215 19	22.00
MNPL.02262026.B.a	MNPL - MN Paid Leave for 2/26/2026 MS Void	02/26/2026	-2.64		
				PAID FAMILY LEAVE-MN 01 L 215 19	-2.64
MNPL.02262026.B.b	MNPL - MN Paid Leave for 2/26/2026 MS RI	02/26/2026	2.64		
				PAID FAMILY LEAVE-MN 01 L 215 19	2.64

## Board Packet

AP Run: 4/27/2026 MPL 1st Qrt — Post Date: 2026-04-27 — AP Run Type: R

Austin Public Schools ISD 492

Check Date	Check Number	Payment Type	Name	Check Amount	
04/27/2026	202003794	Wire Transfer	MN DEPT OF ECONOMIC SECURITY	103,606.20	
Invoice Number	Description	Invoice Date	Invoice Amount	Account	Amount
MNPL.02262026.D	MNPL - MNPL for 2/26/2026 Reg PR	02/26/2026	8,675.18		
				PAID FAMILY LEAVE-MN 01 L 215 19	8,074.16
				PAID FAMILY LEAVE-MN 02 L 215 19	255.95
				PAID FAMILY LEAVE-MN 04 L 215 19	301.68
				PAID FAMILY LEAVE-MN 05 L 215 19	19.83
				PAYROLL W/HOLDINGS-MN PAID LEAVE 11 L 215 19	1.56
				PAYROLL W/HOLDINGS-MN PAID LEAVE 12 L 215 19	22.00
MNPL.02262026.D.a	MNPL - MNPL for 2/26/2026 MS Void	02/26/2026	-2.64		
				PAID FAMILY LEAVE-MN 01 L 215 19	-2.64
MNPL.02262026.D.b	MNPL - MNPL for 2/26/2026 MS RI	02/26/2026	2.64		
				PAID FAMILY LEAVE-MN 01 L 215 19	2.64
MNPL.02272026.B	MNPL - MN Paid Leave for 2/27/2026 Extra	02/27/2026	1.11		
				PAID FAMILY LEAVE-MN 01 L 215 19	1.11
MNPL.02272026.D	MNPL - MNPL for 2/27/2026 Extra	02/27/2026	1.11		
				PAID FAMILY LEAVE-MN 01 L 215 19	1.11
MNPL.03122026.B	MNPL - MN Paid Leave for 3/12/2026 Reg PR	03/12/2026	9,184.83		
				PAID FAMILY LEAVE-MN 01 L 215 19	8,576.05
				PAID FAMILY LEAVE-MN 02 L 215 19	249.07
				PAID FAMILY LEAVE-MN 04 L 215 19	330.71
				PAID FAMILY LEAVE-MN 05 L 215 19	20.77
				PAYROLL W/HOLDINGS-MN PAID LEAVE 11 L 215 19	8.23
MNPL.03122026.B.a	MNPL - MN Paid Leave for 3/12/2026 DH Void	03/12/2026	-2.45		
				PAID FAMILY LEAVE-MN 01 L 215 19	-2.45
MNPL.03122026.B.b	MNPL - MN Paid Leave for 3/12/2026 DH RI	03/12/2026	2.45		
				PAID FAMILY LEAVE-MN 01 L 215 19	2.45
MNPL.03122026.D	MNPL - MNPL for 3/12/2026 Reg PR	03/12/2026	9,184.83		
				PAID FAMILY LEAVE-MN 01 L 215 19	8,576.05
				PAID FAMILY LEAVE-MN 02 L 215 19	249.07
				PAID FAMILY LEAVE-MN 04 L 215 19	330.71

## Board Packet

AP Run: 4/27/2026 MPL 1st Qrt — Post Date: 2026-04-27 — AP Run Type: R

Austin Public Schools ISD 492

Check Date	Check Number	Payment Type	Name	Check Amount	
04/27/2026	202003794	Wire Transfer	MN DEPT OF ECONOMIC SECURITY	103,606.20	
Invoice Number	Description	Invoice Date	Invoice Amount	Account	Amount
			PAID FAMILY LEAVE-MN	05 L 215 19	20.77
			PAYROLL W/HOLDINGS-MN PAID LEAVE	11 L 215 19	8.23
MNPL.03122026.D.a	MNPL - MNPL for 3/12/2026 DH Void	03/12/2026	-2.45		
			PAID FAMILY LEAVE-MN	01 L 215 19	-2.45
MNPL.03122026.D.b	MNPL - MNPL for 3/12/2026 DH RI	03/12/2026	2.45		
			PAID FAMILY LEAVE-MN	01 L 215 19	2.45
MNPL.03262026.B	MNPL - MN Paid Leave for 3/26/2026 Reg PR	03/26/2026	8,234.27		
			PAID FAMILY LEAVE-MN	01 L 215 19	7,781.21
			PAID FAMILY LEAVE-MN	02 L 215 19	153.76
			PAID FAMILY LEAVE-MN	04 L 215 19	272.67
			PAID FAMILY LEAVE-MN	05 L 215 19	19.88
			PAYROLL W/HOLDINGS-MN PAID LEAVE	11 L 215 19	6.75
MNPL.03262026.B.a	MNPL - MN Paid Leave for 3/26/2026 Extra PR	03/26/2026	8.02		
			PAID FAMILY LEAVE-MN	01 L 215 19	8.02
MNPL.03262026.B.b	MNPL - MN Paid Leave for 3/26/2026 HH Void	03/26/2026	-0.40		
			PAID FAMILY LEAVE-MN	01 L 215 19	-0.40
MNPL.03262026.B.c	MNPL - MN Paid Leave for 3/26/2026 HH RI	03/26/2026	0.40		
			PAID FAMILY LEAVE-MN	01 L 215 19	0.40
MNPL.03262026.B.d	MNPL - MN Paid Leave for 3/26/2026 DH Void	03/26/2026	-1.45		
			PAID FAMILY LEAVE-MN	01 L 215 19	-1.45
MNPL.03262026.B.e	MNPL - MN Paid Leave for 3/26/2026 DH RI	03/26/2026	1.45		
			PAID FAMILY LEAVE-MN	01 L 215 19	1.45
MNPL.03262026.D	MNPL - MNPL for 3/26/2026 Reg PR	03/26/2026	8,234.27		
			PAID FAMILY LEAVE-MN	01 L 215 19	7,781.21
			PAID FAMILY LEAVE-MN	02 L 215 19	153.76
			PAID FAMILY LEAVE-MN	04 L 215 19	272.67
			PAID FAMILY LEAVE-MN	05 L 215 19	19.88
			PAYROLL W/HOLDINGS-MN PAID LEAVE	11 L 215 19	6.75

## Board Packet

AP Run: 4/27/2026 MPL 1st Qrt — Post Date: 2026-04-27 — AP Run Type: R

Austin Public Schools ISD 492

Check Date	Check Number	Payment Type	Name	Check Amount	
04/27/2026	202003794	Wire Transfer	MN DEPT OF ECONOMIC SECURITY	103,606.20	
Invoice Number	Description	Invoice Date	Invoice Amount	Account	Amount
MNPL.03262026.D.a	MNPL - MNPL for 3/26/2026 Extra PR	03/26/2026	8.02	PAID FAMILY LEAVE-MN 01 L 215 19	8.02
MNPL.03262026.D.b	MNPL - MNPL for 3/26/2026 HH Void	03/26/2026	-0.40	PAID FAMILY LEAVE-MN 01 L 215 19	-0.40
MNPL.03262026.D.c	MNPL - MNPL for 3/26/2026 HH RI	03/26/2026	0.40	PAID FAMILY LEAVE-MN 01 L 215 19	0.40
MNPL.03262026.D.d	MNPL - MNPL for 3/26/2026 DH Void	03/26/2026	-1.45	PAID FAMILY LEAVE-MN 01 L 215 19	-1.45
MNPL.03262026.D.e	MNPL - MNPL for 3/26/2026 DH RI	03/26/2026	1.45	PAID FAMILY LEAVE-MN 01 L 215 19	1.45
MNPL.03302026.B	MNPL - MN Paid Leave for 3/30/2026 ZS	03/30/2026	5.75	PAID FAMILY LEAVE-MN 01 L 215 19	5.75
MNPL.03302026.D	MNPL - MNPL for 3/30/2026 ZS	03/30/2026	5.75	PAID FAMILY LEAVE-MN 01 L 215 19	5.75
<b>Total:</b>					<b>\$103,606.20</b>

### 4/27/2026 MPL 1st Qrt Summary

Type	Count	Amount
Regular	0	0.00
ACH Checks:	0	0.00
Wire Transfers:	1	103,606.20
Epayables:	0	0.00
<b>Total:</b>	<b>1</b>	<b>\$103,606.20</b>

## Board Packet

AP Run: 4/27/2026 AFLAC — Post Date: 2026-04-27 — AP Run Type: R

Austin Public Schools ISD 492

Check Date	Check Number	Payment Type	Name	Check Amount	
04/27/2026	202003788	Wire Transfer	AFLAC	655.24	
Invoice Number	Description	Invoice Date	Invoice Amount	Account	Amount
AFLAC.03122026.D	AFLAC - AFLAC for 3/12/2026 Reg PR	03/12/2026	327.62		
		PAYROLL W/HOLDINGS-AFLAC DEDUCTIONS		01 L 215 17	277.78
		PAYROLL W/HOLDING-AFLAC DEDUCTIONS		04 L 215 17	49.84
AFLAC.03262026.D	AFLAC - AFLAC for 3/26/2026 Reg PR	03/26/2026	327.62		
		PAYROLL W/HOLDINGS-AFLAC DEDUCTIONS		01 L 215 17	277.78
		PAYROLL W/HOLDING-AFLAC DEDUCTIONS		04 L 215 17	49.84
<b>Total:</b>					<b>\$655.24</b>

### 4/27/2026 AFLAC Summary

Type	Count	Amount
Regular	0	0.00
ACH Checks:	0	0.00
Wire Transfers:	1	655.24
Epayables:	0	0.00
<b>Total:</b>	<b>1</b>	<b>\$655.24</b>

## Board Packet

AP Run: 4/24/2026 PR AP — Post Date: 2026-04-24 — AP Run Type: R

Austin Public Schools ISD 492

Check Date	Check Number	Payment Type	Name	Check Amount	
04/24/2026	60618	Check	A.F.S.C.M.E. COUNCIL 65	3,189.93	
<b>Invoice Number</b>	<b>Description</b>	<b>Invoice Date</b>	<b>Invoice Amount</b>	<b>Account</b>	<b>Amount</b>
AFL.04092026.D	AFL - AFSCM EMP AFL-C for 4/9/2026 Reg PR	04/09/2026	843.05		
	PAYROLL W/HOLDINGS-UNION DUES PAYABLE	01 L 215 06			749.12
	PAYROLL W/HOLDINGS-UNION DUES PAYABLE	02 L 215 06			29.60
	PAYROLL W/HOLDING-UNION DUES PAYABLE	04 L 215 06			58.48
	PAYROLL W/HOLDINGS-UNION DUES PAYABLE	05 L 215 06			5.85
AFL.04232026.D	AFL - AFSCM EMP AFL-C for 4/23/2026 Reg PR	04/23/2026	843.05		
	PAYROLL W/HOLDINGS-UNION DUES PAYABLE	01 L 215 06			749.12
	PAYROLL W/HOLDINGS-UNION DUES PAYABLE	02 L 215 06			29.60
	PAYROLL W/HOLDING-UNION DUES PAYABLE	04 L 215 06			58.48
	PAYROLL W/HOLDINGS-UNION DUES PAYABLE	05 L 215 06			5.85
AFSCM FS. 04092026.D	AFSCM FS - AFSCM FS for 4/9/2026 Reg PR	04/09/2026	744.46		
	PAYROLL W/HOLDINGS-UNION DUES PAYABLE	02 L 215 06			744.46
AFSCM FS. 04232026.D	AFSCM FS - AFSCM FS for 4/23/2026 Reg PR	04/23/2026	759.37		
	PAYROLL W/HOLDINGS-UNION DUES PAYABLE	02 L 215 06			759.37
04/24/2026	60619	Check	AUSTIN EDUCATION ASSOCIATION	16,649.18	
<b>Invoice Number</b>	<b>Description</b>	<b>Invoice Date</b>	<b>Invoice Amount</b>	<b>Account</b>	<b>Amount</b>
AEA ASF.04232026.D	AEA ASF - AEA ASF for 4/23/2026 Reg PR	04/23/2026	214.00		
	PAYROLL W/HOLDINGS-AEA DUES	01 L 215 16			208.00
	PAYROLL W/HOLDING-AEA DUES	04 L 215 16			6.00
AEA.04232026.D	AEA - UNION DUES1 for 4/23/2026 Reg PR	04/23/2026	16,435.18		
	PAYROLL W/HOLDINGS-AEA DUES	01 L 215 16			16,250.30
	PAYROLL W/HOLDING-AEA DUES	04 L 215 16			184.88
04/24/2026	60620	Check	AUSTIN PUBLIC EDUCATION FOUNDATION	304.34	
<b>Invoice Number</b>	<b>Description</b>	<b>Invoice Date</b>	<b>Invoice Amount</b>	<b>Account</b>	<b>Amount</b>
AEF.04092026.D	AEF - AUSTIN EDUC FOU for 4/9/2026 Reg PR	04/09/2026	152.17		
	PAYROLL W/HOLDINGS-CHARITABLE CONTRIBUTIONS	01 L 215 11			143.17

## Board Packet

AP Run: 4/24/2026 PR AP — Post Date: 2026-04-24 — AP Run Type: R

Austin Public Schools ISD 492

Check Date	Check Number	Payment Type	Name	Check Amount		
04/24/2026	60620	Check	AUSTIN PUBLIC EDUCATION FOUNDATION	304.34		
<u>Invoice Number</u>	<u>Description</u>		<u>Invoice Date</u>	<u>Invoice Amount</u>	<u>Account</u>	<u>Amount</u>
			PAYROLL W/HOLDING-CHARITABLE CONTRIBUTIONS	04 L 215 11		9.00
AEF.04232026.D	AEF - AUSTIN EDUC FOU for 4/23/2026 Reg PR		04/23/2026	152.17		
			PAYROLL W/HOLDINGS-CHARITABLE CONTRIBUTIONS	01 L 215 11		143.17
			PAYROLL W/HOLDING-CHARITABLE CONTRIBUTIONS	04 L 215 11		9.00
04/24/2026	60621	Check	LOCAL 867	2,330.32		
<u>Invoice Number</u>	<u>Description</u>		<u>Invoice Date</u>	<u>Invoice Amount</u>	<u>Account</u>	<u>Amount</u>
UAW.04092026.D	UAW - UAW L. 867 for 4/9/2026 Reg PR		04/09/2026	1,165.16		
			PAYROLL W/HOLDINGS-UNION DUES PAYABLE	01 L 215 06		1,116.22
			PAYROLL W/HOLDINGS-UNION DUES PAYABLE	02 L 215 06		20.04
			PAYROLL W/HOLDING-UNION DUES PAYABLE	04 L 215 06		28.90
UAW.04232026.D	UAW - UAW L. 867 for 4/23/2026 Reg PR		04/23/2026	1,165.16		
			PAYROLL W/HOLDINGS-UNION DUES PAYABLE	01 L 215 06		1,116.22
			PAYROLL W/HOLDINGS-UNION DUES PAYABLE	02 L 215 06		20.04
			PAYROLL W/HOLDING-UNION DUES PAYABLE	04 L 215 06		28.90
04/24/2026	60622	Check	MN SCHOOL EMPLOYEES ASSN	2,053.43		
<u>Invoice Number</u>	<u>Description</u>		<u>Invoice Date</u>	<u>Invoice Amount</u>	<u>Account</u>	<u>Amount</u>
MSEA 2%.04232026.D	MSEA 2% - MSEA 2% for 4/23/2026 Reg PR		04/23/2026	2,053.43		
			PAYROLL W/HOLDINGS-UNION DUES PAYABLE	01 L 215 06		2,053.43
04/24/2026	60623	Check	UNITED WAY OF MOWER COUNTY	257.00		
<u>Invoice Number</u>	<u>Description</u>		<u>Invoice Date</u>	<u>Invoice Amount</u>	<u>Account</u>	<u>Amount</u>
UNF.04092026.D	UNF - UNITED FUND for 4/9/2026 Reg PR		04/09/2026	128.50		
			PAYROLL W/HOLDINGS-CHARITABLE CONTRIBUTIONS	01 L 215 11		128.50
UNF.04232026.D	UNF - UNITED FUND for 4/23/2026 Reg PR		04/23/2026	128.50		
			PAYROLL W/HOLDINGS-CHARITABLE CONTRIBUTIONS	01 L 215 11		128.50

## Board Packet

AP Run: 4/24/2026 PR AP — Post Date: 2026-04-24 — AP Run Type: R

Austin Public Schools ISD 492

Check Date	Check Number	Payment Type	Name			Check Amount
04/24/2026	202003789	Wire Transfer	ALERUS			47,755.11
Invoice Number	Description	Invoice Date	Invoice Amount	Account	Amount	
HDHSA.04232026.D	HDHSA - FAMILY HIGH DEDUCTIBLE HSA for 4/23/2026 Reg PR	04/23/2026	39,295.60			
				PAYROLL W/HOLDINGS-HSA PAYABLE 01 L 215 40	38,167.68	
				PAYROLL W/HOLDINGS-HSA PAYABLE 02 L 215 40	205.00	
				PAYROLL W/HOLDING-HSA PAYABLE 04 L 215 40	657.12	
				PAYROLL W/HOLDINGS-HSA PAYABLE 05 L 215 40	265.80	
HDHSAS.04232026.D	HDHSAS - SINGLE HIGH DEDUCTIBLE HSA for 4/23/2026 Reg PR	04/23/2026	8,459.51			
				PAYROLL W/HOLDINGS-HSA PAYABLE 01 L 215 40	7,927.03	
				PAYROLL W/HOLDINGS-HSA PAYABLE 02 L 215 40	25.00	
				PAYROLL W/HOLDING-HSA PAYABLE 04 L 215 40	507.48	
04/24/2026	202003790	Wire Transfer	AVIBEN LLC			49,879.96
Invoice Number	Description	Invoice Date	Invoice Amount	Account	Amount	
AIG.04232026.B	AIG - AIG RETIREMENT for 4/23/2026 Reg PR	04/23/2026	909.50			
				PAYROLL W/HOLDINGS-TAX SHELTER ANNUITIES 01 L 215 05	909.50	
AIG.04232026.D	AIG - AIG RETIREMENT for 4/23/2026 Reg PR	04/23/2026	3,450.89			
				PAYROLL W/HOLDINGS-TAX SHELTER ANNUITIES 01 L 215 05	3,450.89	
HRMA.04232026.B	HRMA - HORACE MANN COMPANY for 4/23/2026 Reg PR	04/23/2026	3,006.77			
				PAYROLL W/HOLDINGS-TAX SHELTER ANNUITIES 01 L 215 05	3,006.77	
HRMA.04232026.D	HRMA - HORACE MANN CO for 4/23/2026 Reg PR	04/23/2026	8,317.89			
				PAYROLL W/HOLDINGS-TAX SHELTER ANNUITIES 01 L 215 05	8,317.89	
MNDPC.04232026.D	MNDPC - MN DEFFERED COMP for 4/23/2026 Reg PR	04/23/2026	1,934.00			
				PAYROLL W/HOLDINGS-TAX SHELTER ANNUITIES 01 L 215 05	1,934.00	
ORC.04232026.D	ORC - ORCHARD TRUST for 4/23/2026 Reg PR	04/23/2026	50.00			
				PAYROLL W/HOLDINGS-TAX SHELTER ANNUITIES 01 L 215 05	50.00	
SBG.04232026.B	SBG - SECURITY BENEFIT GROUP for 4/23/2026 Reg PR	04/23/2026	7,285.57			
				PAYROLL W/HOLDINGS-TAX SHELTER ANNUITIES 01 L 215 05	6,091.36	
				PAYROLL W/HOLDINGS-TAX SHELTER ANNUITIES 02 L 215 05	764.75	
				PAYROLL W/HOLDING-TAX SHELTER ANNUITIES 04 L 215 05	291.00	

## Board Packet

AP Run: 4/24/2026 PR AP — Post Date: 2026-04-24 — AP Run Type: R

Austin Public Schools ISD 492

Check Date	Check Number	Payment Type	Name	Check Amount	
04/24/2026	202003790	Wire Transfer	AVIBEN LLC	49,879.96	
<b>Invoice Number</b>	<b>Description</b>	<b>Invoice Date</b>	<b>Invoice Amount</b>	<b>Account</b>	<b>Amount</b>
SBG.04232026.D	SBG - SECURITY BENEFIT GROUP for 4/23/2026 Reg PR	04/23/2026	17,609.76	PAYROLL W/HOLDINGS-TAX SHELTER ANNUITIES 05 L 215 05	138.46
				PAYROLL W/HOLDINGS-TAX SHELTER ANNUITIES 01 L 215 05	16,522.76
				PAYROLL W/HOLDINGS-TAX SHELTER ANNUITIES 02 L 215 05	796.00
				PAYROLL W/HOLDING-TAX SHELTER ANNUITIES 04 L 215 05	291.00
SBGR.04232026.D	SBGR - SECURITY BENEFIT GROUP ROTH for 4/23/2026 Reg PR	04/23/2026	7,315.58	PAYROLL W/HOLDINGS-TAX SHELTER ANNUITIES 01 L 215 05	7,045.12
				PAYROLL W/HOLDINGS-TAX SHELTER ANNUITIES 02 L 215 05	100.00
				PAYROLL W/HOLDINGS-TAX SHELTER ANNUITIES 05 L 215 05	170.46
04/24/2026	202003791	Wire Transfer	MINNESOTA DEPT OF REVENUE	73,138.01	
<b>Invoice Number</b>	<b>Description</b>	<b>Invoice Date</b>	<b>Invoice Amount</b>	<b>Account</b>	<b>Amount</b>
MN\$.04232026.D	MN\$ - MN ADD ON for 4/23/2026 Reg PR	04/23/2026	1,809.00	PAYROLL W/HOLDINGS-STATE WITHHOLDING 01 L 215 02	1,464.00
				PAYROLL W/HOLDINGS-STATE WITHHOLDING 02 L 215 02	40.00
				PAYROLL W/HOLDING-STATE WITHHOLDING 04 L 215 02	305.00
MN%.04232026.D	MN% - MN STATE TAX% for 4/23/2026 Reg PR	04/23/2026	67.90	PAYROLL W/HOLDINGS-STATE WITHHOLDING 01 L 215 02	16.42
				PAYROLL W/HOLDINGS-STATE WITHHOLDING 02 L 215 02	51.48
MN.04232026.D	MN - MN STATE TAX for 4/23/2026 Reg PR	04/23/2026	71,025.31	PAYROLL W/HOLDINGS-STATE WITHHOLDING 01 L 215 02	66,662.56
				PAYROLL W/HOLDINGS-STATE WITHHOLDING 02 L 215 02	1,488.06
				PAYROLL W/HOLDING-STATE WITHHOLDING 04 L 215 02	2,399.57
				PAYROLL W/HOLDINGS-STATE WITHHOLDING 05 L 215 02	196.74
				PAYROLL W/HOLDINGS-STATE WITHHOLDING 11 L 215 02	6.26
				PAYROLL W/HOLDINGS-STATE WITHHOLDING 12 L 215 02	272.12
MN.04242026.D	MN - MN STATE TAX for 4/24/2026 Extra PR	04/24/2026	235.80	PAYROLL W/HOLDINGS-STATE WITHHOLDING 01 L 215 02	227.13

## Board Packet

AP Run: 4/24/2026 PR AP — Post Date: 2026-04-24 — AP Run Type: R

Austin Public Schools ISD 492

Check Date	Check Number	Payment Type	Name	Check Amount
04/24/2026	202003791	Wire Transfer	MINNESOTA DEPT OF REVENUE	73,138.01
<b>Invoice Number</b>	<b>Description</b>		<b>Invoice Date</b>	<b>Invoice Amount</b>
			PAYROLL W/HOLDINGS-STATE WITHHOLDING	02 L 215 02
				8.67
04/24/2026	202003792	Wire Transfer	MN CHILD SUPPORT PAYMENT CENT	1,047.30
<b>Invoice Number</b>	<b>Description</b>		<b>Invoice Date</b>	<b>Invoice Amount</b>
MCS.04232026.D	MCS - MN CHILD SUPP1 for 4/23/2026 Reg PR		04/23/2026	1,047.30
			PAYROLL W/HOLDINGS-MISC DED PAYABLE	01 L 215 14
			PAYROLL W/HOLDING-MISC DED PAYABLE	04 L 215 14
				980.86
				66.44
04/24/2026	202003793	Wire Transfer	UNITED STATES TREASURY	422,068.73
<b>Invoice Number</b>	<b>Description</b>		<b>Invoice Date</b>	<b>Invoice Amount</b>
FE\$.04232026.D	FE\$ - FED ADD-ON AMT for 4/23/2026 Reg PR		04/23/2026	7,494.57
			PAYROLL W/HOLDINGS-FEDERAL WITHHOLDINGS	01 L 215 01
			PAYROLL W/HOLDINGS-FEDERAL WITHHOLDINGS	02 L 215 01
			PAYROLL W/HOLDING-FEDERAL WITHHOLDINGS	04 L 215 01
				6,849.57
				25.00
				620.00
FE%.04232026.D	FE% - FEDERAL TAX% for 4/23/2026 Reg PR		04/23/2026	283.98
			PAYROLL W/HOLDINGS-FEDERAL WITHHOLDINGS	01 L 215 01
			PAYROLL W/HOLDINGS-FEDERAL WITHHOLDINGS	02 L 215 01
				187.75
				96.23
FED.04232026.D	FED - FED TAX for 4/23/2026 Reg PR		04/23/2026	125,612.61
			PAYROLL W/HOLDINGS-FEDERAL WITHHOLDINGS	01 L 215 01
			PAYROLL W/HOLDINGS-FEDERAL WITHHOLDINGS	02 L 215 01
			PAYROLL W/HOLDING-FEDERAL WITHHOLDINGS	04 L 215 01
			PAYROLL W/HOLDINGS-FEDERAL WITHHOLDINGS	05 L 215 01
			PAYROLL W/HOLDINGS-FEDERAL WITHHOLDINGS	11 L 215 01
			PAYROLL W/HOLDINGS-FEDERAL WITHHOLDINGS	12 L 215 01
				119,047.49
				2,056.34
				3,543.96
				362.23
				11.78
				590.81
FED.04242026.D	FED - FED TAX for 4/24/2026 Extra PR		04/24/2026	548.19
			PAYROLL W/HOLDINGS-FEDERAL WITHHOLDINGS	01 L 215 01
			PAYROLL W/HOLDINGS-FEDERAL WITHHOLDINGS	02 L 215 01
				548.19
				0.00
FIC.04232026.B	FIC - FICA for 4/23/2026 Reg PR		04/23/2026	116,470.10
			PAYROLL W/HOLDINGS-FEDERAL WITHHOLDINGS	01 L 215 01
			PAYROLL W/HOLDINGS-FEDERAL WITHHOLDINGS	02 L 215 01
				107,932.23
				3,425.07

## Board Packet

AP Run: 4/24/2026 PR AP — Post Date: 2026-04-24 — AP Run Type: R

Austin Public Schools ISD 492

Check Date	Check Number	Payment Type	Name	Check Amount	
04/24/2026	202003793	Wire Transfer	UNITED STATES TREASURY	422,068.73	
Invoice Number	Description	Invoice Date	Invoice Amount	Account	Amount
			PAYROLL W/HOLDING-FEDERAL WITHHOLDINGS	04 L 215 01	4,529.72
			PAYROLL W/HOLDINGS-FEDERAL WITHHOLDINGS	05 L 215 01	263.78
			PAYROLL W/HOLDINGS-FEDERAL WITHHOLDINGS	11 L 215 01	9.30
			PAYROLL W/HOLDINGS-FEDERAL WITHHOLDINGS	12 L 215 01	310.00
FIC.04232026.D	FIC - FICA for 4/23/2026 Reg PR	04/23/2026	116,470.10		
			PAYROLL W/HOLDINGS-FEDERAL WITHHOLDINGS	01 L 215 01	107,932.23
			PAYROLL W/HOLDINGS-FEDERAL WITHHOLDINGS	02 L 215 01	3,425.07
			PAYROLL W/HOLDING-FEDERAL WITHHOLDINGS	04 L 215 01	4,529.72
			PAYROLL W/HOLDINGS-FEDERAL WITHHOLDINGS	05 L 215 01	263.78
			PAYROLL W/HOLDINGS-FEDERAL WITHHOLDINGS	11 L 215 01	9.30
			PAYROLL W/HOLDINGS-FEDERAL WITHHOLDINGS	12 L 215 01	310.00
FIC.04242026.B	FIC - FICA for 4/24/2026 Extra PR	04/24/2026	288.23		
			PAYROLL W/HOLDINGS-FEDERAL WITHHOLDINGS	01 L 215 01	265.50
			PAYROLL W/HOLDINGS-FEDERAL WITHHOLDINGS	02 L 215 01	22.73
FIC.04242026.D	FIC - FICA for 4/24/2026 Extra PR	04/24/2026	288.23		
			PAYROLL W/HOLDINGS-FEDERAL WITHHOLDINGS	01 L 215 01	265.50
			PAYROLL W/HOLDINGS-FEDERAL WITHHOLDINGS	02 L 215 01	22.73
MED.04232026.B	MED - MEDICARE-1 for 4/23/2026 Reg PR	04/23/2026	27,238.95		
			PAYROLL W/HOLDINGS-FEDERAL WITHHOLDINGS	01 L 215 01	25,242.21
			PAYROLL W/HOLDINGS-FEDERAL WITHHOLDINGS	02 L 215 01	801.00
			PAYROLL W/HOLDING-FEDERAL WITHHOLDINGS	04 L 215 01	1,059.37
			PAYROLL W/HOLDINGS-FEDERAL WITHHOLDINGS	05 L 215 01	61.70
			PAYROLL W/HOLDINGS-FEDERAL WITHHOLDINGS	11 L 215 01	2.17
			PAYROLL W/HOLDINGS-FEDERAL WITHHOLDINGS	12 L 215 01	72.50
MED.04232026.D	MED - MEDICARE1 for 4/23/2026 Reg PR	04/23/2026	27,238.95		
			PAYROLL W/HOLDINGS-FEDERAL WITHHOLDINGS	01 L 215 01	25,242.21
			PAYROLL W/HOLDINGS-FEDERAL WITHHOLDINGS	02 L 215 01	801.00
			PAYROLL W/HOLDING-FEDERAL WITHHOLDINGS	04 L 215 01	1,059.37

## Board Packet

AP Run: 4/24/2026 PR AP — Post Date: 2026-04-24 — AP Run Type: R

Austin Public Schools ISD 492

Check Date	Check Number	Payment Type	Name	Check Amount	
04/24/2026	202003793	Wire Transfer	UNITED STATES TREASURY	422,068.73	
Invoice Number	Description	Invoice Date	Invoice Amount	Account	Amount
			PAYROLL W/HOLDINGS-FEDERAL WITHHOLDINGS	05 L 215 01	61.70
			PAYROLL W/HOLDINGS-FEDERAL WITHHOLDINGS	11 L 215 01	2.17
			PAYROLL W/HOLDINGS-FEDERAL WITHHOLDINGS	12 L 215 01	72.50
MED.04242026.B	MED - MEDICARE-1 for 4/24/2026 Extra PR	04/24/2026	67.41		
			PAYROLL W/HOLDINGS-FEDERAL WITHHOLDINGS	01 L 215 01	62.09
			PAYROLL W/HOLDINGS-FEDERAL WITHHOLDINGS	02 L 215 01	5.32
MED.04242026.D	MED - MEDICARE1 for 4/24/2026 Extra PR	04/24/2026	67.41		
			PAYROLL W/HOLDINGS-FEDERAL WITHHOLDINGS	01 L 215 01	62.09
			PAYROLL W/HOLDINGS-FEDERAL WITHHOLDINGS	02 L 215 01	5.32
				<b>Total:</b>	<b>\$618,673.31</b>

### 4/24/2026 PR AP Summary

Type	Count	Amount
Regular	6	24,784.20
ACH Checks:	0	0.00
Wire Transfers:	5	593,889.11
Epayables:	0	0.00
<b>Total:</b>	<b>11</b>	<b>\$618,673.31</b>

## Board Packet

AP Run: T261004 — Post Date: 2026-04-28 — AP Run Type: R

Austin Public Schools ISD 492

Check Date	Check Number	Payment Type	Name	Check Amount	
04/28/2026	60624	Check	AMAZON BUSINESS	11,001.74	
Invoice Number	Description	Invoice Date	Invoice Amount	Account	Amount
11LW-XCFX-H7TP	CLASSROOM MATERIALS	04/23/2026	145.64		
				INDIV INST SUPPLIES-ECSE--IDEA SEC 619 01 E 120 412 000 420 433	145.64
14DR-6XY7-CXTC	SUPPLIES FOR BANFIELD PARENT ENGAGEMENT EVENT - 4/30/2026	04/21/2026	706.22		
				GEN SUPPLIES-TITLE I-PR YR PARENTAL INVOLV-TITLE I 01 E 105 216 631 401 401	706.22
14R4-4F9N-CKHX	SOCIAL WORKER SUPPLIES	04/20/2026	222.14		
				INST SUPPLIES-SOCIAL WORK SVC- 01 E 125 740 000 000 430	222.14
166Q-9RLJ-7TRK	CLASSROOM SUPPLIES	04/15/2026	887.09		
				INDIV INST SUPPLIES-FACS-HOME EC-CTE 01 E 310 331 459 809 433	887.09
16FP-QWRG-GCQV	SUPPLIES FOR BANFIELD PARENT ENGAGEMENT EVENT - 4/30/2026	04/21/2026	194.27		
				GEN SUPPLIES-TITLE I-PR YR PARENTAL INVOLV-TITLE I 01 E 105 216 631 401 401	194.27
16L9-M61D-MR6Q	SECTION BASEBALLS	04/23/2026	499.75		
				GEN SUPPLIES-BOY/GIRL--STATE/SCTN.GATE 11 E 310 292 000 161 401	499.75
173P-WD4H-QRHG	ECSE MATERIALS	04/18/2026	191.42		
				INDIV INST SUPPLIES-ECSE--IDEA SEC 619 01 E 120 412 000 420 433	191.42
174D-3FTP-Q4J9	SPEECH MATERIALS	04/18/2026	125.41		
				INDIV INST SUPPLIES-SPEECH--STATE SPED 01 E 005 401 000 740 433	50.17
				INDIV INST SUPPLIES-SPEECH--STATE SPED 01 E 185 401 000 740 433	75.24
17CX-HKQG-1W9Y	SUMMER SCHOOL JOURNALS	04/22/2026	520.87		
				INSTRUCTL SUPPLIES-ELEM ED--ALC 01 E 220 203 000 303 430	520.87
17FF-QMTR-3QVX	SCHOOL SUPPLIES	04/22/2026	1,369.74		
				INSTRUCTIONAL SUP-ABE--STATE ABE 04 E 500 520 000 322 430	47.97
				GEN SUPPLIES-ECFE--ECFE 04 E 500 580 000 325 401	1,321.77
17QV-6639-L3JT	CLASSROOM SUPPLIES	04/16/2026	184.20		
				INSTRUCTL SUPPLIES-SOCIAL STUDIES-- 01 E 310 270 000 000 430	184.20
17WK-LGJN-FNRP	OT MATERIALS	04/22/2026	261.35		
				INDIV INST SUPPLIES-SPED AGG--STATE SPED 01 E 005 420 000 740 433	155.13
				INDIV INST SUPPLIES-ECSE--IDEA SEC 619 01 E 120 412 000 420 433	106.22

## Board Packet

AP Run: T261004 — Post Date: 2026-04-28 — AP Run Type: R

Austin Public Schools ISD 492

Check Date	Check Number	Payment Type	Name	Check Amount	
04/28/2026	60624	Check	AMAZON BUSINESS	11,001.74	
Invoice Number	Description	Invoice Date	Invoice Amount	Account	Amount
1937-LCV9-DXQD	HENOYSO NOTEBOOKS-M. THEOBALD	04/16/2026	85.45		
		GEN SUPPLIES-ELEM ED--		01 E 105 203 000 000 401	85.45
19LT-9H1N-CC1P	CLASSROOM MATERIALS	04/20/2026	97.24		
		GEN SUPPLIES-ECSE--IDEA SEC 619		01 E 120 412 000 420 401	97.24
1CNX-WDCT-HJPK	NHS PROJECT SUPPLIES	04/20/2026	88.36		
		SUPPLIES & MATERIALS-EXT CUR-NAT HON SOC-SA		88 E 310 298 045 301 401	88.36
1CXH-WCGD-KNQC	ECSE MATERIALS	04/20/2026	26.75		
		INDIV INST SUPPLIES-ECSE--IDEA SEC 619		01 E 120 412 000 420 433	26.75
1DQQ-HYX6-G6W4	ART INSTRUCTION - SULLIVAN	04/22/2026	83.94		
		INSTRUCTL SUPPLIES-ART--		01 E 185 212 000 000 430	83.94
1DW9-FVYN-7VFT	SUPPLIES FOR BANFIELD PARENT ENGAGEMENT EVENT - 4/30/2026	04/14/2026	80.87		
		GEN SUPPLIES-TITLE I-PR YR PARENTAL INVOLV-TITLE I		01 E 105 216 631 401 401	80.87
1FP4-GTNP-JJPY	SUPPLIES	04/23/2026	169.59		
		GEN SUPPLIES-ELEM ED--		01 E 125 203 000 000 401	169.59
1FPH-6F7M-TNL1	CLASSROOM MATERIALS	04/04/2026	112.55		
		INDIV INST SUPPLIES-EBD--STATE SPED		01 E 125 408 000 740 433	88.52
		INDIV INST SUPPLIES-ASD--STATE SPED		01 E 125 411 000 740 433	24.03
1GXH-X4KM-9GRH	CONCESSION SUPPLIES	04/20/2026	107.45		
		COST OF MAT SOLD-BOY/GIRL--ACTIVITIES REV.		11 R 000 292 000 147 619	107.45
1HM7-QGMR-F4PD	GENERAL BUILDING/OFFICE SUPPLIES	04/21/2026	93.24		
		GEN SUPPLIES-ELEM ED--		01 E 155 203 000 000 401	93.24
1HNM-FJVV-3WK1	TESTING EARBUDS	04/13/2026	200.98		
		INST TECH SUPPLIES-SEC-		01 E 310 211 000 000 456	200.98
1JHJ-QVYQ-GJFH	CLASSROOM MATERIALS	04/22/2026	63.64		
		INDIV INST SUPPLIES-EBD--STATE SPED		01 E 125 408 000 740 433	63.64
1KH7-QFKK-YRKH	ART SUPPLIES	04/12/2026	468.88		
		INSTRUCTL SUPPLIES-ART--		01 E 210 212 000 000 430	468.88

## Board Packet

AP Run: T261004 — Post Date: 2026-04-28 — AP Run Type: R

Austin Public Schools ISD 492

Check Date	Check Number	Payment Type	Name	Check Amount	
04/28/2026	60624	Check	AMAZON BUSINESS	11,001.74	
Invoice Number	Description	Invoice Date	Invoice Amount	Account	Amount
1KXL-XDW3-7MDM	CLASSROOM SUPPLIES	04/15/2026	317.93		
				INSTRUCTL SUPPLIES-SOCIAL STUDIES-- 01 E 310 270 000 000 430	317.93
1LTD-RTH4-76RD	N. EDWARDS-GENERAL SUPPLIES	04/17/2026	458.10		
				GEN SUPPLIES-ELEM ED-- 01 E 105 203 000 000 401	158.40
				INST TECH SUPPLIES-ELEM ED-- 01 E 105 203 000 000 456	299.70
1M9K-7JGN-3K7H	BOOKS	04/13/2026	28.79		
				INSTRUCTL SUPPLIES-SOCIAL STUDIES-- 01 E 310 270 000 000 430	28.79
1MFL-NF3G-9DM9	SPEECH MATERIALS	04/21/2026	373.88		
				INDIV INST SUPPLIES-SPEECH--STATE SPED 01 E 005 401 000 740 433	149.56
				INDIV INST SUPPLIES-SPEECH--STATE SPED 01 E 185 401 000 740 433	224.32
1N1K-LFJD-MFHV	CONCESSION SUPPLIES	04/20/2026	90.00		
				COST OF MAT SOLD-BOY/GIRL--ACTIVITIES REV. 11 R 000 292 000 147 619	90.00
1PCC-KTJX-CRPD	OT MATERIAL	04/20/2026	37.80		
				INDIV INST SUPPLIES-SPED AGG--STATE SPED 01 E 005 420 000 740 433	37.80
1PDX-XCKC-7FWY	ATHLETIC SUPPLIES	04/07/2026	27.98		
				GEN SUPPLIES-BOY/GIRL-- 01 E 210 292 000 000 401	27.98
1PH6-6C4M-XQLH	MEDIA CENTER - GENERAL SUPPLIES	04/24/2026	58.18		
				GEN SUPPLIES-MEDIA CENTER-- 01 E 185 620 000 000 401	58.18
1RJ1-7LG1-44Q1	CONCESSION SUPPLIES	04/15/2026	1,259.95		
				COST OF MAT SOLD-BOY/GIRL--ACTIVITIES REV. 11 R 000 292 000 147 619	1,259.95
1VRT-6C3Y-YW93	CLASSROOM MATERIALS	04/12/2026	59.25		
				INDIV INST SUPPLIES-EBD--STATE SPED 01 E 125 408 000 740 433	8.95
				INDIV INST SUPPLIES-ASD--STATE SPED 01 E 125 411 000 740 433	50.30
1VX7-K4LD-9CH4	MAINTENANCE SUPPLIES	04/15/2026	249.95		
				REPAIR SUPPLIES-OPERATIONS-- 01 E 005 810 000 000 420	249.95
1WPC-9X49-X49H	SUPPLIES	04/24/2026	76.26		
				INSTRUCTL SUPPLIES-ELEM ED-- 01 E 125 203 000 000 430	76.26
1XJ9-VTXX-J4Q9	MAINTENANCE AND OFFICE SUPPLIES	04/20/2026	32.37		
				REPAIR SUPPLIES-OPERATIONS-- 01 E 005 810 000 000 420	32.37

## Board Packet

AP Run: T261004 — Post Date: 2026-04-28 — AP Run Type: R

Austin Public Schools ISD 492

Check Date	Check Number	Payment Type	Name	Check Amount	
04/28/2026	60624	Check	AMAZON BUSINESS	11,001.74	
Invoice Number	Description	Invoice Date	Invoice Amount	Account	Amount
1XMG-TPWW-GYDC	MAINTENANCE SUPPLY-SPRINKLER GUARD	04/20/2026	53.32		
		REPAIR SUPPLIES-OPERATIONS--		01 E 005 810 000 000 420	53.32
1XTH-K3YC-9DDJ	CLASS SUPPLIES	04/13/2026	311.33		
		INSTRUCTIONAL SUPPLIES-HEALTH/PE-MISC GRANTS-		01 E 310 240 804 000 430	311.33
1YPM-HNC1-P9GT	GENERAL BUILDING/OFFICE SUPPLIES	04/18/2026	579.61		
		GEN SUPPLIES-ELEM ED--		01 E 155 203 000 000 401	579.61
04/28/2026	60625	Check	AMERICAN TIME & SIGNAL	926.52	
Invoice Number	Description	Invoice Date	Invoice Amount	Account	Amount
895747	NEVELN-CLOCK	02/23/2026	926.52		
		GEN SUPPLIES-ELEM ED--		01 E 125 203 000 000 401	926.52
04/28/2026	60626	Check	ANCOM COMMUNICATIONS	309.00	
Invoice Number	Description	Invoice Date	Invoice Amount	Account	Amount
132102	IMPRES 2150 BATTERY	02/19/2026	147.00		
		BATTERY REPLACEMENT-OPERATIONS--		01 E 005 810 000 000 411	147.00
132943	HOLTON/ELLIS TECH SERVICE	04/09/2026	20.00		
		REPAIR & MAINT SVCS-OPERATIONS--		01 E 005 810 000 000 350	20.00
132952	IMPRES 2100 BATTERY	04/09/2026	142.00		
		BATTERY REPLACEMENT-OPERATIONS--		01 E 005 810 000 000 411	142.00
04/28/2026	60627	Check	ANFINSON, PAMELA M	169.17	
Invoice Number	Description	Invoice Date	Invoice Amount	Account	Amount
042126	MILEAGE REIM - MASE	04/21/2026	74.31		
		TRAVEL CONV & CONF-SPED AGG-PRO DEV-IDEA-611		01 E 005 420 640 419 366	74.31
042226	MILEAGE REIM - MASE	04/22/2026	72.07		
		TRAVEL CONV & CONF-SPED AGG-PRO DEV-IDEA-611		01 E 005 420 640 419 366	72.07
8131260618	DINNER REIM - MASE NEW DIRECTORS COHORT	04/21/2026	22.79		
		TRAVEL CONV & CONF-SPED AGG-PRO DEV-IDEA-611		01 E 005 420 640 419 366	22.79

## Board Packet

AP Run: T261004 — Post Date: 2026-04-28 — AP Run Type: R

Austin Public Schools ISD 492

Check Date	Check Number	Payment Type	Name			Check Amount
04/28/2026	60628	Check	AUNG, NINN T			18.35
<b>Invoice Number</b>	<b>Description</b>		<b>Invoice Date</b>	<b>Invoice Amount</b>	<b>Account</b>	<b>Amount</b>
98031825055876947 561	WALMART REIM		04/17/2026	18.35		
			GEN SUPPLIES-ELEM ED-SUMNER-SUMNER GEN		11 E 155 203 015 119 401	18.35
04/28/2026	60629	Check	BSN SPORTS			400.30
<b>Invoice Number</b>	<b>Description</b>		<b>Invoice Date</b>	<b>Invoice Amount</b>	<b>Account</b>	<b>Amount</b>
933901035	GOLF UNIFORMS		04/14/2026	400.30		
			GEN SUPPLIES-GIRLS ATHL-GOLF		66 E 310 296 114 000 401	400.30
04/28/2026	60630	Check	CARTER, KATIE			526.11
<b>Invoice Number</b>	<b>Description</b>		<b>Invoice Date</b>	<b>Invoice Amount</b>	<b>Account</b>	<b>Amount</b>
P5NCBVYNR	HOTEL ROOM 3/23/26-3/26/26		03/26/2026	526.11		
			TRAVEL/CONFERENCE-STAFF DEV-DIRECTOR CARTER, K		55 E 310 640 005 000 366	526.11
04/28/2026	60631	Check	CESO HR LLC			1,020.00
<b>Invoice Number</b>	<b>Description</b>		<b>Invoice Date</b>	<b>Invoice Amount</b>	<b>Account</b>	<b>Amount</b>
1971	HR GENERALIST SUPPORT		04/22/2026	1,020.00		
			FEES FOR SERVICES-BUSINESS OFFICE--		01 E 005 110 000 000 305	1,020.00
04/28/2026	60632	Check	CHRISTOPHERSON, ANNE M			1,464.32
<b>Invoice Number</b>	<b>Description</b>		<b>Invoice Date</b>	<b>Invoice Amount</b>	<b>Account</b>	<b>Amount</b>
06486I	PUMP HAUS REIM - ROBOTICS		03/27/2026	435.65		
			FOOD-EXT CUR-AHS-ROBOTICS		11 E 310 298 040 150 490	435.65
10548996	KWIKSTAR REIM - ROBOTICS		03/28/2026	109.30		
			FOOD-EXT CUR-AHS-ROBOTICS		11 E 310 298 040 150 490	109.30
1284859	CASEY'S REIM - ROBOTICS		03/25/2026	15.68		
			FOOD-EXT CUR-AHS-ROBOTICS		11 E 310 298 040 150 490	15.68
21112500603862603 211805	COSTCO REIM - ROBOTICS		03/21/2026	290.54		
			FOOD-EXT CUR-AHS-ROBOTICS		11 E 310 298 040 150 490	290.54
2674299434211	PANCHEROS REIM - ROBOTICS		03/26/2026	293.50		
			FOOD-EXT CUR-AHS-ROBOTICS		11 E 310 298 040 150 490	293.50

## Board Packet

AP Run: T261004 — Post Date: 2026-04-28 — AP Run Type: R

Austin Public Schools ISD 492

Check Date	Check Number	Payment Type	Name	Check Amount		
04/28/2026	60632	Check	CHRISTOPHERSON, ANNE M	1,464.32		
<u>Invoice Number</u>	<u>Description</u>		<u>Invoice Date</u>	<u>Invoice Amount</u>	<u>Account</u>	<u>Amount</u>
33751572515396880 5114	WALMART REIM - ROBOTICS		03/25/2026	100.33		
			FOOD-EXT CUR-AHS-ROBOTICS		11 E 310 298 040 150 490	100.33
4254673818165	PANCHEROS REIM - ROBOTICS		03/26/2026	12.73		
			FOOD-EXT CUR-AHS-ROBOTICS		11 E 310 298 040 150 490	12.73
497	DOMINOS REIM - ROBOTICS		03/22/2026	74.00		
			FOOD-EXT CUR-AHS-ROBOTICS		11 E 310 298 040 150 490	74.00
M045530325- 150763011	CASEY'S GENERAL STORE REIM - ROBOTICS		03/25/2026	132.59		
			FOOD-EXT CUR-AHS-ROBOTICS		11 E 310 298 040 150 490	132.59
04/28/2026	60633	Check	CONSORTIUM FOR SCHOOL NETWORKING	1,050.00		
<u>Invoice Number</u>	<u>Description</u>		<u>Invoice Date</u>	<u>Invoice Amount</u>	<u>Account</u>	<u>Amount</u>
255730	INSTITUTIONAL MEMBER: MEDIUM DISTRICT/COSN MN CHAPTER FEE		04/09/2026	1,050.00		
			PREPAID EXPENDITURE & DEPOSITS-		01 A 131 00	1,050.00
04/28/2026	60634	Check	CULLIGAN ULTRPURE INC	105.00		
<u>Invoice Number</u>	<u>Description</u>		<u>Invoice Date</u>	<u>Invoice Amount</u>	<u>Account</u>	<u>Amount</u>
33033662-03312026	BLANKET PO FOR FISCAL YEAR 2025-2026		03/31/2026	105.00		
			REPAIR SUPPLIES-OPERATIONS--		01 E 005 810 000 000 420	105.00
04/28/2026	60635	Check	DAKOTA SUPPLY GROUP	384.41		
<u>Invoice Number</u>	<u>Description</u>		<u>Invoice Date</u>	<u>Invoice Amount</u>	<u>Account</u>	<u>Amount</u>
S105532661.001	2ND BLANKET PO FY 25-26		03/23/2026	213.79		
			REPAIR SUPPLIES-OPERATIONS--		01 E 005 810 000 000 420	213.79
S105537886.001	2ND BLANKET PO FY 25-26		03/24/2026	170.62		
			REPAIR SUPPLIES-OPERATIONS--		01 E 005 810 000 000 420	170.62

## Board Packet

AP Run: T261004 — Post Date: 2026-04-28 — AP Run Type: R

Austin Public Schools ISD 492

Check Date	Check Number	Payment Type	Name	Check Amount		
04/28/2026	60636	Check	EBELING, CHRISTINA	1,512.56		
<u>Invoice Number</u>	<u>Description</u>		<u>Invoice Date</u>	<u>Invoice Amount</u>	<u>Account</u>	<u>Amount</u>
23933062	FFA STATE ROOMS APRIL 19-21, 2026		04/21/2026	1,512.56		
	ENTRY FEES/STDT TRVL ALLOW-EXT CUR-FFA-SA				88 E 310 298 026 301 369	1,512.56
04/28/2026	60637	Check	FRUHWIRTH, SARAH L	67.61		
<u>Invoice Number</u>	<u>Description</u>		<u>Invoice Date</u>	<u>Invoice Amount</u>	<u>Account</u>	<u>Amount</u>
64720927223799565 320	WALMART REIM		04/20/2026	67.61		
	GEN SUPPLIES-ELEM ED-SUMNER-SUMNER GEN				11 E 155 203 015 119 401	67.61
04/28/2026	60638	Check	GALLAGHER BENEFIT SERVICES INC	300.00		
<u>Invoice Number</u>	<u>Description</u>		<u>Invoice Date</u>	<u>Invoice Amount</u>	<u>Account</u>	<u>Amount</u>
2026051216	ONGOING CONSULTING		04/16/2026	300.00		
	FEES FOR SERVICES-PERSONNEL--				01 E 005 160 000 000 305	300.00
04/28/2026	60639	Check	GOPHER STAGE LIGHTING INC	712.00		
<u>Invoice Number</u>	<u>Description</u>		<u>Invoice Date</u>	<u>Invoice Amount</u>	<u>Account</u>	<u>Amount</u>
INV25435	KNOWLTON-REPAIR		03/25/2026	712.00		
	REPAIR & MAINT SVCS-OPERATIONS--				01 E 005 810 000 000 350	712.00
04/28/2026	60640	Check	HOLT, MICHELLE	200.00		
<u>Invoice Number</u>	<u>Description</u>		<u>Invoice Date</u>	<u>Invoice Amount</u>	<u>Account</u>	<u>Amount</u>
114-7004895- 8342639	AMAZON REIM		04/23/2026	200.00		
	INSTRUCTL SUPPLIES-VOL PRE-KINDERG--				01 E 135 200 000 000 430	200.00
04/28/2026	60641	Check	HOVLAND, EMILY T	146.60		
<u>Invoice Number</u>	<u>Description</u>		<u>Invoice Date</u>	<u>Invoice Amount</u>	<u>Account</u>	<u>Amount</u>
041126	MILEAGE REIM - STATE STUDENT COUNCIL		04/11/2026	44.95		
	ENT FEES/STDT TRVL ALLOW-EXT CUR-STD CNCL-AHS-SA				88 E 310 298 053 301 369	44.95
041226	MILEAGE REIM - STATE STUDENT COUNCIL		04/12/2026	44.95		
	ENT FEES/STDT TRVL ALLOW-EXT CUR-STD CNCL-AHS-SA				88 E 310 298 053 301 369	44.95

## Board Packet

AP Run: T261004 — Post Date: 2026-04-28 — AP Run Type: R

Austin Public Schools ISD 492

Check Date	Check Number	Payment Type	Name	Check Amount		
04/28/2026	60641	Check	HOVLAND, EMILY T	146.60		
<b>Invoice Number</b>	<b>Description</b>		<b>Invoice Date</b>	<b>Invoice Amount</b>	<b>Account</b>	<b>Amount</b>
0909-4716-4799-2604-0603	CEO WALGREENS REIM		04/06/2026	56.70		
			GEN SUPPLIES-SEC-CEO PROGRAM-		01 E 310 211 206 000 401	56.70
04/28/2026	60642	Check	IEA	6,040.21		
<b>Invoice Number</b>	<b>Description</b>		<b>Invoice Date</b>	<b>Invoice Amount</b>	<b>Account</b>	<b>Amount</b>
00062741	2025-2026 ENVIRONMENTAL, HEALTH, AND SAFETY MANAGEMENT SERVICES MONTHLY PROFESSIONAL SERVICES		04/09/2026	6,040.21		
			FEES FOR SERVICES-LTFM--ENVIRON SAFETY		05 E 005 865 000 352 305	6,040.21
04/28/2026	60643	Check	JENNIFER LINNETT, PLLC	3,795.00		
<b>Invoice Number</b>	<b>Description</b>		<b>Invoice Date</b>	<b>Invoice Amount</b>	<b>Account</b>	<b>Amount</b>
31	MENTAL HEALTH SUPERVISOR 3/25/26		03/25/2026	920.00		
			PMTS FOR ED PURPOSE TO OTH AG-EBD--		01 E 312 408 000 000 394	920.00
32	MENTAL HEALTH SUPERVISOR 4/1/26		04/01/2026	920.00		
			PMTS FOR ED PURPOSE TO OTH AG-EBD--		01 E 312 408 000 000 394	920.00
33	MENTAL HEALTH SUPERVISOR 4/8/26		04/08/2026	920.00		
			PMTS FOR ED PURPOSE TO OTH AG-EBD--		01 E 312 408 000 000 394	920.00
34	MENTAL HEALTH SUPERVISOR 4/15/26		04/15/2026	1,035.00		
			PMTS FOR ED PURPOSE TO OTH AG-EBD--		01 E 312 408 000 000 394	1,035.00
04/28/2026	60644	Check	JUNIOR ACHIEVEMENT NORTH	500.00		
<b>Invoice Number</b>	<b>Description</b>		<b>Invoice Date</b>	<b>Invoice Amount</b>	<b>Account</b>	<b>Amount</b>
2026-0529	JA FINANCE PARK MOBILE CURRICULUM & SIMULATION FOR AUSTIN ALC		03/19/2026	500.00		
			STU TRV ALLOW/ENT FEE-SEC--ALC		01 E 610 211 000 303 369	500.00
04/28/2026	60645	Check	KASSON-MANTORVILLE SCHOOL	250.00		
<b>Invoice Number</b>	<b>Description</b>		<b>Invoice Date</b>	<b>Invoice Amount</b>	<b>Account</b>	<b>Amount</b>
011726	GIRLS BASKETBALL 1/17/26		01/17/2026	250.00		
			ENTRY FEES/STDT TRVL ALLOW-GIRLS ATHL-BASKETBALL-		01 E 310 296 102 000 369	250.00

## Board Packet

AP Run: T261004 — Post Date: 2026-04-28 — AP Run Type: R

Austin Public Schools ISD 492

Check Date	Check Number	Payment Type	Name	Check Amount	
04/28/2026	60646	Check	LEWIS, DEBRA A	55.48	
<b>Invoice Number</b>	<b>Description</b>	<b>Invoice Date</b>	<b>Invoice Amount</b>	<b>Account</b>	<b>Amount</b>
28104565660539191 094	WALMART REIM	04/20/2026	55.48		
	GEN SUPPLIES-ELEM ED-SUMNER-SUMNER GEN			11 E 155 203 015 119 401	55.48
04/28/2026	60647	Check	MADISON NATIONAL LIFE	32,888.09	
<b>Invoice Number</b>	<b>Description</b>	<b>Invoice Date</b>	<b>Invoice Amount</b>	<b>Account</b>	<b>Amount</b>
1753355	MAR 2026 LIFE INSURANCE	03/01/2026	16,756.98		
	PAYROLL W/HOLDINGS-DEP LIFE PAYABLE			01 L 215 00	78.66
	PAYROLL W/HOLDINGS-LTD INS PAYABLE			01 L 215 09	8,979.94
	PAYROLL W/HOLDINGS-LIFE INS PAYABLE			01 L 215 13	3,844.88
	PAYROLL W/HOLDINGS-SPOUSE LIFE INS PAYABLE			01 L 215 25	521.55
	PAYROLL W/HOLDINGS-PRUDENTIAL SUPP ITCR			01 L 215 26	3,331.95
1758581	APR 2026 LIFE INSURANCE	04/01/2026	16,131.11		
	PAYROLL W/HOLDINGS-DEP LIFE PAYABLE			01 L 215 00	64.17
	PAYROLL W/HOLDINGS-LTD INS PAYABLE			01 L 215 09	8,701.76
	PAYROLL W/HOLDINGS-LIFE INS PAYABLE			01 L 215 13	3,601.38
	PAYROLL W/HOLDINGS-SPOUSE LIFE INS PAYABLE			01 L 215 25	502.15
	PAYROLL W/HOLDINGS-PRUDENTIAL SUPP ITCR			01 L 215 26	3,261.65
04/28/2026	60648	Check	MARREEL, DANIEL P	425.00	
<b>Invoice Number</b>	<b>Description</b>	<b>Invoice Date</b>	<b>Invoice Amount</b>	<b>Account</b>	<b>Amount</b>
042226	STATE FOOD ADAPTED BOWLING	04/22/2026	425.00		
	ENTRY FEE/STDT TRVL-BOY/GIRL ATHL-ADAPTIVE BOWLING			01 E 310 292 120 000 369	425.00
04/28/2026	60649	Check	MASMS	500.00	
<b>Invoice Number</b>	<b>Description</b>	<b>Invoice Date</b>	<b>Invoice Amount</b>	<b>Account</b>	<b>Amount</b>
040926	MASMS CPS CLASS - JOE ADAMSON	04/09/2026	500.00		
	TRAVEL/CONFERENCE-STAFF DEV-DIRECTOR ADAMSON, J			55 E 005 640 004 000 366	500.00

## Board Packet

AP Run: T261004 — Post Date: 2026-04-28 — AP Run Type: R

Austin Public Schools ISD 492

Check Date	Check Number	Payment Type	Name	Check Amount
04/28/2026	60650	Check	MIDDLE LEVEL BAND DIRECTORS ASSN	448.00
<b>Invoice Number</b>	<b>Description</b>	<b>Invoice Date</b>	<b>Invoice Amount</b>	<b>Account</b>
2026115	HONOR BAND REGISTRATION - IJ	02/12/2026	448.00	
			ENTRY FEES/STDT TRVL ALLOW-MUSIC--BAND	11 E 185 258 000 132 369
				448.00
04/28/2026	60651	Check	MINNESOTA INSTITUTE FOR TALENTED YOUTH	4,400.00
<b>Invoice Number</b>	<b>Description</b>	<b>Invoice Date</b>	<b>Invoice Amount</b>	<b>Account</b>
18674	RESIDENTIAL EYM SESSION B	03/09/2026	2,200.00	
			PMT FOR ED PURP-GIFTED-HRML GT-MITY-HORMEL	01 E 005 218 083 063 394
				2,200.00
18675	RESIDENTIAL EYM SESSION B	03/09/2026	2,200.00	
			PMT FOR ED PURP-GIFTED-HRML GT-MITY-HORMEL	01 E 005 218 083 063 394
				2,200.00
04/28/2026	60652	Check	MISSISSIPPI WELDERS SUPPLY CO INC	144.12
<b>Invoice Number</b>	<b>Description</b>	<b>Invoice Date</b>	<b>Invoice Amount</b>	<b>Account</b>
2023860	OPEN PO FOR CLASS SUPPLIES	04/01/2026	80.00	
			INDIV INST SUPPLIES-TRAD/IND-WELDING-CTE	01 E 310 361 868 817 433
				80.00
2025370	OPEN PO FOR CLASS SUPPLIES	03/31/2026	22.32	
			INDIV INST SUPPLIES-TRAD/IND-WELDING-CTE	01 E 310 361 868 817 433
				22.32
4798271	OPEN PO FOR CLASS SUPPLIES	04/07/2026	41.80	
			INDIV INST SUPPLIES-TRAD/IND-WELDING-CTE	01 E 310 361 868 817 433
				41.80
04/28/2026	60653	Check	MK MUSIC REPAIR	41.78
<b>Invoice Number</b>	<b>Description</b>	<b>Invoice Date</b>	<b>Invoice Amount</b>	<b>Account</b>
34342	TENOR SAXOPHONE REPAIR	03/26/2026	41.78	
			REPAIR & MAINT SVCS-MUSIC-ELLIS-BAND	11 E 210 258 030 132 350
				41.78
04/28/2026	60654	Check	MOA ENTERTAINMENT COMPANY LLC	500.00
<b>Invoice Number</b>	<b>Description</b>	<b>Invoice Date</b>	<b>Invoice Amount</b>	<b>Account</b>
MMOANG-045014-20260504	CEO - MOA MARKETING TOUR	04/21/2026	500.00	
			PMT FOR ED PURP-SEC-CEO PROGRAM-	01 E 310 211 206 000 394
				500.00

## Board Packet

AP Run: T261004 — Post Date: 2026-04-28 — AP Run Type: R

Austin Public Schools ISD 492

Check Date	Check Number	Payment Type	Name	Check Amount	
04/28/2026	60655	Check	MOWER COUNTY HUMANE SOCIETY	45.00	
<b>Invoice Number</b>	<b>Description</b>	<b>Invoice Date</b>	<b>Invoice Amount</b>	<b>Account</b>	<b>Amount</b>
041026	CHECK TO MOWER COUNTY HUMANE SOCIETY - DONATION FROM MAAP STARS (ALC)	04/10/2026	45.00		
	MISC EXPENSES-EXTRA CURR-STU CNL/ALC CLUB-EC-SA	88 E 610 298 099 301 899			45.00
04/28/2026	60656	Check	MUSIC MART	1,132.77	
<b>Invoice Number</b>	<b>Description</b>	<b>Invoice Date</b>	<b>Invoice Amount</b>	<b>Account</b>	<b>Amount</b>
1995889	BAND SUPPLIES	03/16/2026	643.04		
				INSTRUCTL SUPPLIES-MUSIC-- 01 E 310 258 000 000 430	643.04
2007776	ORCHESTRA SUPPLIES	04/13/2026	39.95		
				INSTRUCTL SUPPLIES-MUSIC-- 01 E 210 258 000 000 430	39.95
2008233	CHOIR SUPPLIES	04/14/2026	449.78		
				INSTRUCTL SUPPLIES-MUSIC-- 01 E 210 258 000 000 430	449.78
04/28/2026	60657	Check	NEXUS-GERARD FAMILY HEALING	193.77	
<b>Invoice Number</b>	<b>Description</b>	<b>Invoice Date</b>	<b>Invoice Amount</b>	<b>Account</b>	<b>Amount</b>
127730	INSTRUCTION	04/17/2026	193.77		
	FED SUB AWARD<25K-TITL I-NEG/DELINQUENT-TITLE I-A	01 E 450 216 636 401 303			193.77
04/28/2026	60658	Check	OFFICE OF MNIT SERVICES	38.85	
<b>Invoice Number</b>	<b>Description</b>	<b>Invoice Date</b>	<b>Invoice Amount</b>	<b>Account</b>	<b>Amount</b>
W26030731	INTERPRETER SERVICES MARCH 2026	04/15/2026	38.85		
	PMT FOR ED PURP-SPED AGG--STATE SPED	01 E 005 420 000 740 394			38.85
04/28/2026	60659	Check	OPG-3 INC	410.00	
<b>Invoice Number</b>	<b>Description</b>	<b>Invoice Date</b>	<b>Invoice Amount</b>	<b>Account</b>	<b>Amount</b>
9713	SKYWARD QMLATIV WORKFLOW UPDATES	04/16/2026	410.00		
	FEES FOR SERVICES-BUSINESS OFFICE--	01 E 005 110 000 000 305			410.00
04/28/2026	60660	Check	PALMER BUS SERVICE	418.27	
<b>Invoice Number</b>	<b>Description</b>	<b>Invoice Date</b>	<b>Invoice Amount</b>	<b>Account</b>	<b>Amount</b>
INV17334	AHS FORGE WELDING COMPETITION	04/15/2026	418.27		
	TRANS CONTRACT-PUPIL TRANS--NON-AUTH TRAN	01 E 005 760 000 733 360			418.27

## Board Packet

AP Run: T261004 — Post Date: 2026-04-28 — AP Run Type: R

Austin Public Schools ISD 492

Check Date	Check Number	Payment Type	Name	Check Amount	
04/28/2026	60661	Check	PERFORMANCE TOURS	3,412.80	
<b>Invoice Number</b>	<b>Description</b>	<b>Invoice Date</b>	<b>Invoice Amount</b>	<b>Account</b>	<b>Amount</b>
202646	HOME 2 SUITES & READY BUS CO	03/18/2026	3,412.80		
	ENTRY FEES/STDT TRAVEL-MUSIC-DISTRICT INITIATIVE			01 E 310 258 492 000 369	3,412.80
04/28/2026	60662	Check	QUILL CORPORATION	902.89	
<b>Invoice Number</b>	<b>Description</b>	<b>Invoice Date</b>	<b>Invoice Amount</b>	<b>Account</b>	<b>Amount</b>
48375486	OFFICE SUPPLIES	03/31/2026	674.93		
				GEN SUPPLIES-SEC-- 01 E 210 211 000 000 401	674.93
48382312	OFFICE SUPPLIES	04/01/2026	227.96		
				GEN SUPPLIES-SEC-- 01 E 210 211 000 000 401	227.96
04/28/2026	60663	Check	RAVENHORST, ELLERY	564.82	
<b>Invoice Number</b>	<b>Description</b>	<b>Invoice Date</b>	<b>Invoice Amount</b>	<b>Account</b>	<b>Amount</b>
08700010808203252 60	CEO - HOBBY LOBBY REIM	03/25/2026	34.64		
				GEN SUPPLIES-SEC-CEO PROGRAM- 01 E 310 211 206 000 401	34.64
08700010899103032 63	CEO - HOBBY LOBBY REIM	03/03/2026	53.65		
				GEN SUPPLIES-SEC-CEO PROGRAM- 01 E 310 211 206 000 401	53.65
08700070228712042 59	CEO - HOBBY LOBBY REIM	12/04/2025	9.86		
				GEN SUPPLIES-SEC-CEO PROGRAM- 01 E 310 211 206 000 401	9.86
111-1190066- 2289001	CEO - AMAZON REIM	01/29/2026	4.79		
				GEN SUPPLIES-SEC-CEO PROGRAM- 01 E 310 211 206 000 401	4.79
111-1254551- 8014637	CEO - AMAZON REIM	03/26/2026	7.54		
				GEN SUPPLIES-SEC-CEO PROGRAM- 01 E 310 211 206 000 401	7.54
111-3949551- 9705805	CEO - AMAZON REIM	07/14/2025	13.50		
				GEN SUPPLIES-SEC-CEO PROGRAM- 01 E 310 211 206 000 401	13.50

## Board Packet

AP Run: T261004 — Post Date: 2026-04-28 — AP Run Type: R

Austin Public Schools ISD 492

Check Date	Check Number	Payment Type	Name	Check Amount	
04/28/2026	60663	Check	RAVENHORST, ELLERY	564.82	
Invoice Number	Description	Invoice Date	Invoice Amount	Account	Amount
111-6260667-7574636	CEO - AMAZON REIM	01/29/2026	5.38		
		GEN SUPPLIES-SEC-CEO PROGRAM-	01 E 310 211 206 000 401	5.38	
111-7572478-2960234	CEO - AMAZON REIM	03/25/2026	5.38		
		GEN SUPPLIES-SEC-CEO PROGRAM-	01 E 310 211 206 000 401	5.38	
111-7691424-4434631	CEO - AMAZON REIM	03/24/2026	8.13		
		GEN SUPPLIES-SEC-CEO PROGRAM-	01 E 310 211 206 000 401	8.13	
111-9622053-8922620	CEO - AMAZON REIM	12/18/2025	8.72		
		GEN SUPPLIES-SEC-CEO PROGRAM-	01 E 310 211 206 000 401	8.72	
1123SC050321263817	CEO - SAVERS REIM	03/21/2026	98.82		
		GEN SUPPLIES-SEC-CEO PROGRAM-	01 E 310 211 206 000 401	98.82	
112-5138925-8261826	CEO - AMAZON REIM	01/03/2026	36.65		
		GEN SUPPLIES-SEC-CEO PROGRAM-	01 E 310 211 206 000 401	36.65	
3-31153	CEO - CALICO HUTCH REIM	12/15/2025	69.96		
		GEN SUPPLIES-SEC-CEO PROGRAM-	01 E 310 211 206 000 401	69.96	
3-31154	CEO - CALICO HUTCH REIM	12/15/2025	7.15		
		GEN SUPPLIES-SEC-CEO PROGRAM-	01 E 310 211 206 000 401	7.15	
3-31193	CEO - CALICO HUTCH REIM	12/17/2025	26.51		
		GEN SUPPLIES-SEC-CEO PROGRAM-	01 E 310 211 206 000 401	26.51	
3-31291	CEO - CALICO HUTCH REIM	12/22/2025	60.66		
		GEN SUPPLIES-SEC-CEO PROGRAM-	01 E 310 211 206 000 401	60.66	
3-32810	CEO - CALICO HUTCH REIM	03/04/2026	52.16		
		GEN SUPPLIES-SEC-CEO PROGRAM-	01 E 310 211 206 000 401	52.16	
58543964039683758973	CEO - WALMART REIM	03/17/2026	35.32		
		GEN SUPPLIES-SEC-CEO PROGRAM-	01 E 310 211 206 000 401	35.32	

## Board Packet

AP Run: T261004 — Post Date: 2026-04-28 — AP Run Type: R

Austin Public Schools ISD 492

Check Date	Check Number	Payment Type	Name	Check Amount
04/28/2026	60663	Check	RAVENHORST, ELLERY	564.82
<b>Invoice Number</b>	<b>Description</b>	<b>Invoice Date</b>	<b>Invoice Amount</b>	<b>Account</b>
8041395	CEO - GOODWILL REIM	03/21/2026	26.00	
		GEN SUPPLIES-SEC-CEO PROGRAM-	01 E 310 211 206 000 401	26.00
04/28/2026	60664	Check	RIVERLAND COMMUNITY COLLEGE	463,894.68
<b>Invoice Number</b>	<b>Description</b>	<b>Invoice Date</b>	<b>Invoice Amount</b>	<b>Account</b>
00186569	TUITION FOR PSEO STUDENTS - SPRING TERM	04/08/2026	463,894.68	
		PMT FOR ED PURP-SEC--PSEO CONTRACT	01 E 310 211 000 090 394	463,894.68
04/28/2026	60665	Check	ROOT RIVER HARDWOODS INC	1,515.00
<b>Invoice Number</b>	<b>Description</b>	<b>Invoice Date</b>	<b>Invoice Amount</b>	<b>Account</b>
32379	HARD MAPLE S35 15/16 SL W BROWNS	04/01/2026	1,515.00	
		RESALE SUP-TRAD/IND-WOOD/ELEC.-CTE	01 E 310 361 863 817 621	1,515.00
04/28/2026	60666	Check	RUNNINGS	59.37
<b>Invoice Number</b>	<b>Description</b>	<b>Invoice Date</b>	<b>Invoice Amount</b>	<b>Account</b>
4004234	MAINTENANCE SUPPLIES 2ND BLANKET PO FY 2025-2026	04/14/2026	59.37	
		REPAIR SUPPLIES-OPERATIONS--	01 E 005 810 000 000 420	59.37
04/28/2026	60667	Check	SIGN SOLUTIONS, INC	88.75
<b>Invoice Number</b>	<b>Description</b>	<b>Invoice Date</b>	<b>Invoice Amount</b>	<b>Account</b>
28287	SWIM RECORD BANNERS	04/07/2026	88.75	
		GEN SUPPLIES-GIRLS-SWIM & DIVE-	01 E 310 296 108 000 401	88.75
04/28/2026	60668	Check	SMYTH COMPANIES LLC	313.53
<b>Invoice Number</b>	<b>Description</b>	<b>Invoice Date</b>	<b>Invoice Amount</b>	<b>Account</b>
257224PB-2	MMEA PROGRAMS	02/17/2026	313.53	
		GEN SUPPLIES-MUSIC-AHS-CHOIR	11 E 310 258 040 133 401	313.53
04/28/2026	60669	Check	TRAFERA HOLDINGS LLC	36,650.00
<b>Invoice Number</b>	<b>Description</b>	<b>Invoice Date</b>	<b>Invoice Amount</b>	<b>Account</b>
1001555346	LAB AND TINY REFRESH	04/08/2026	36,650.00	
		NON-INST TECH DEVICE-INST TECH-ASSIGNED TECH-	01 E 005 630 093 000 465	13,194.00

## Board Packet

AP Run: T261004 — Post Date: 2026-04-28 — AP Run Type: R

Austin Public Schools ISD 492

Check Date	Check Number	Payment Type	Name	Check Amount	
04/28/2026	60669	Check	TRAFERA HOLDINGS LLC	36,650.00	
<b>Invoice Number</b>	<b>Description</b>	<b>Invoice Date</b>	<b>Invoice Amount</b>	<b>Account</b>	<b>Amount</b>
	INST TECH DEVICE-INST TECH-ASSIGNED TECH-	01 E 005 630 093 000 466			23,456.00
04/28/2026	60670	Check	TREVIPAY - WALMART	994.16	
<b>Invoice Number</b>	<b>Description</b>	<b>Invoice Date</b>	<b>Invoice Amount</b>	<b>Account</b>	<b>Amount</b>
113DBA99	OPEN PO 2 FLORAL DESIGN VASES, FAKE AND REAL FLOWERS	04/23/2026	50.04		
		INDIV INST SUPPLIES-AGRI-FARM OPER-CTE	01 E 310 301 501 801 433		50.04
28712158	OPEN PO 2 FLORAL DESIGN VASES, FAKE AND REAL FLOWERS	04/16/2026	25.40		
		INDIV INST SUPPLIES-AGRI-FARM OPER-CTE	01 E 310 301 501 801 433		25.40
2B3EEAC9	FAMILY LIT SUPPLIES	04/21/2026	96.45		
		INSTRUCTIONAL SUP-ABE-HRML FAM LIT-GED TESTING	04 E 500 520 240 324 430		96.45
3E9BC08D	FOOD AND SUPPLIES FOR NAPAC	04/21/2026	603.33		
		GEN SUPPLIES-OTH PUP SUP--AM INDIAN ED AID	01 E 005 790 000 320 401		308.69
		FOOD-OTH PUP SUP--AM INDIAN ED AID	01 E 005 790 000 320 490		294.64
4FB43B55	OPEN PO FOR CLASS SUPPLIES 1	04/21/2026	32.28		
		INDIV INST SUPPLIES-FACS-HOME EC-CTE	01 E 310 331 459 809 433		32.28
70ABEE52	OPEN PO 2 FLORAL DESIGN VASES, FAKE AND REAL FLOWERS	04/16/2026	13.59		
		INDIV INST SUPPLIES-AGRI-FARM OPER-CTE	01 E 310 301 501 801 433		13.59
74DAB6AF	OPEN PO FOR CLASS SUPPLIES 1	04/24/2026	39.80		
		INDIV INST SUPPLIES-FACS-HOME EC-CTE	01 E 310 331 459 809 433		39.80
7D21BDD0	OPEN PO 2 FLORAL DESIGN VASES, FAKE AND REAL FLOWERS	04/20/2026	29.92		
		INDIV INST SUPPLIES-AGRI-FARM OPER-CTE	01 E 310 301 501 801 433		29.92
B04194AC	INCENTIVES	04/22/2026	79.35		
		INDIV INST SUPPLIES-EBD--STATE SPED	01 E 105 408 000 740 433		79.35
B9284F6D	OPEN PO 2	04/16/2026	24.00		

## Board Packet

AP Run: T261004 — Post Date: 2026-04-28 — AP Run Type: R

Austin Public Schools ISD 492

Check Date	Check Number	Payment Type	Name	Check Amount	
04/28/2026	60670	Check	TREVIPAY - WALMART	994.16	
Invoice Number	Description	Invoice Date	Invoice Amount	Account	Amount
	FLORAL DESIGN VASES, FAKE AND REAL FLOWERS				
			INDIV INST SUPPLIES-AGRI-FARM OPER-CTE	01 E 310 301 501 801 433	24.00
04/28/2026	60671	Check	UNITED WAY OF MOWER COUNTY	45.00	
Invoice Number	Description	Invoice Date	Invoice Amount	Account	Amount
041026	DONATION TO UNITED WAY/ AHS PACKER PANTRY	04/10/2026	45.00		
			MISC EXPENSES-EXTRA CURR-STU CNL/ALC CLUB-EC-SA	88 E 610 298 099 301 899	45.00
04/28/2026	60672	Check	WHITE, CHELSEA M	504.36	
Invoice Number	Description	Invoice Date	Invoice Amount	Account	Amount
1898-9768	CHARTING THE C'S CONF 2026 REGISTRATION REIM	02/13/2026	150.00		
			TRAVEL CONV & CONF-SPED AGG-PRO DEV-IDEA-611	01 E 005 420 640 419 366	150.00
R02FEE	MADDENS ON GULL LAKE REIM - CHARTING THE C'S CONF	04/22/2026	354.36		
			TRAVEL CONV & CONF-SPED AGG-PRO DEV-IDEA-611	01 E 005 420 640 419 366	354.36
04/28/2026	60673	Check	YMCA OF AUSTIN MN	200.00	
Invoice Number	Description	Invoice Date	Invoice Amount	Account	Amount
162762	EVENT/MEETING ROOM RENTAL - MCA TESTING FOR AOA	04/15/2026	200.00		
			SHORT TERM LEASE/RENTAL-SECONDARY--	01 E 175 211 000 000 335	200.00
				<b>Total:</b>	<b>\$581,685.39</b>

### T261004 Summary

Type	Count	Amount
Regular	50	581,685.39
ACH Checks:	0	0.00
Wire Transfers:	0	0.00
Epayables:	0	0.00
<b>Total:</b>	<b>50</b>	<b>\$581,685.39</b>

## Board Packet

AP Run: CB261004 — Post Date: 2026-04-28 — AP Run Type: R

Austin Public Schools ISD 492

Check Date	Check Number	Payment Type	Name	Check Amount	
04/28/2026	5000002778		CAVALIER COACHES, INC*	1,615.00	
<b>Invoice Number</b>	<b>Description</b>	<b>Invoice Date</b>	<b>Invoice Amount</b>	<b>Account</b>	<b>Amount</b>
21036	4/17/26 CE DAY TRIP - THRIFT SHOP TWIN CITIES	04/20/2026	1,615.00		
	FEES FOR SERVICES-GEN COM ED-FIELD TRIP-COM ED			04 E 500 505 404 321 305	1,615.00
04/28/2026	5000002779		CONTINENTAL CLAY CO*	157.01	
<b>Invoice Number</b>	<b>Description</b>	<b>Invoice Date</b>	<b>Invoice Amount</b>	<b>Account</b>	<b>Amount</b>
INV000213993	BUFF STONEWARE	02/10/2026	157.01		
	INSTRUCTL SUPPLIES-ART--			01 E 310 212 000 000 430	157.01
04/28/2026	5000002780		FOLLETT LIBRARY RESOURCES*	3,002.48	
<b>Invoice Number</b>	<b>Description</b>	<b>Invoice Date</b>	<b>Invoice Amount</b>	<b>Account</b>	<b>Amount</b>
708127	LIBRARY BOOKS	02/25/2026	2,312.26		
	LIBRARY BOOKS-MEDIA CENTER--			01 E 125 620 000 000 470	2,312.26
708127A	LIBRARY BOOKS	03/05/2026	547.14		
	LIBRARY BOOKS-MEDIA CENTER--			01 E 125 620 000 000 470	547.14
708127F	LIBRARY BOOKS	04/07/2026	143.08		
	LIBRARY BOOKS-MEDIA CENTER--			01 E 125 620 000 000 470	143.08
04/28/2026	5000002781		GAMES PEOPLE PLAY*	816.00	
<b>Invoice Number</b>	<b>Description</b>	<b>Invoice Date</b>	<b>Invoice Amount</b>	<b>Account</b>	<b>Amount</b>
10411-1	BOYS VOLLEYBALL JACKETS	04/15/2026	816.00		
	GENERAL SUPPLIES-BOYS ATHL-VOLLEYBALL-			66 E 310 294 116 000 401	816.00
04/28/2026	5000002782		HILLYARD/HUTCHINSON*	12,538.44	
<b>Invoice Number</b>	<b>Description</b>	<b>Invoice Date</b>	<b>Invoice Amount</b>	<b>Account</b>	<b>Amount</b>
90008112	FOOD SERVICE SUPPLIES	01/27/2026	406.08		
	GEN SUPPLIES-FOOD SVC--NSLP			02 E 005 770 000 701 401	406.08
90008531	FOOD SREVICE SUPPLIES	01/27/2026	2,301.12		
	GEN SUPPLIES-FOOD SVC--NSLP			02 E 005 770 000 701 401	2,301.12
90100860	3RD BLANKET PO FOR FISCAL YEAR 2025-2026	04/08/2026	1,342.91		
	CUSTODIAL SUPPLIES-OPERATIONS--			01 E 005 810 000 000 410	1,342.91
90102100	3RD BLANKET PO FOR FISCAL YEAR 2025-2026	04/09/2026	169.94		
	CUSTODIAL SUPPLIES-OPERATIONS--			01 E 005 810 000 000 410	169.94

## Board Packet

AP Run: CB261004 — Post Date: 2026-04-28 — AP Run Type: R

Austin Public Schools ISD 492

Check Date	Check Number	Payment Type	Name	Check Amount	
04/28/2026	5000002782		HILLYARD/HUTCHINSON*	12,538.44	
Invoice Number	Description	Invoice Date	Invoice Amount	Account	Amount
90102101	3RD BLANKET PO FOR FISCAL YEAR 2025-2026	04/09/2026	180.21		
				CUSTODIAL SUPPLIES-OPERATIONS-- 01 E 005 810 000 000 410	180.21
90104474	3RD BLANKET PO FOR FISCAL YEAR 2025-2026	04/10/2026	1,720.61		
				CUSTODIAL SUPPLIES-OPERATIONS-- 01 E 005 810 000 000 410	1,720.61
90104475	3RD BLANKET PO FOR FISCAL YEAR 2025-2026	04/10/2026	1,811.94		
				CUSTODIAL SUPPLIES-OPERATIONS-- 01 E 005 810 000 000 410	1,811.94
90104476	3RD BLANKET PO FOR FISCAL YEAR 2025-2026	04/10/2026	794.20		
				CUSTODIAL SUPPLIES-OPERATIONS-- 01 E 005 810 000 000 410	794.20
90104477	3RD BLANKET PO FOR FISCAL YEAR 2025-2026	04/10/2026	195.84		
				CUSTODIAL SUPPLIES-OPERATIONS-- 01 E 005 810 000 000 410	195.84
90104478	3RD BLANKET PO FOR FISCAL YEAR 2025-2026	04/10/2026	54.24		
				CUSTODIAL SUPPLIES-OPERATIONS-- 01 E 005 810 000 000 410	54.24
90105774	3RD BLANKET PO FOR FISCAL YEAR 2025-2026	04/13/2026	21.54		
				CUSTODIAL SUPPLIES-OPERATIONS-- 01 E 005 810 000 000 410	21.54
90105775	3RD BLANKET PO FOR FISCAL YEAR 2025-2026	04/13/2026	65.07		
				CUSTODIAL SUPPLIES-OPERATIONS-- 01 E 005 810 000 000 410	65.07
90108040	4TH BLANKET PO FOR FISCAL YEAR 2025-2026	04/15/2026	165.20		
				CUSTODIAL SUPPLIES-OPERATIONS-- 01 E 005 810 000 000 410	165.20
90109345	4TH BLANKET PO FOR FISCAL YEAR 2025-2026	04/15/2026	263.09		
				CUSTODIAL SUPPLIES-OPERATIONS-- 01 E 005 810 000 000 410	263.09
90112189	4TH BLANKET PO FOR FISCAL YEAR 2025-2026	04/17/2026	826.11		
				CUSTODIAL SUPPLIES-OPERATIONS-- 01 E 005 810 000 000 410	826.11
90112190	4TH BLANKET PO FOR FISCAL YEAR 2025-2026	04/17/2026	191.60		
				CUSTODIAL SUPPLIES-OPERATIONS-- 01 E 005 810 000 000 410	191.60
90112191	4TH BLANKET PO FOR FISCAL YEAR 2025-2026	04/17/2026	19.80		
				CUSTODIAL SUPPLIES-OPERATIONS-- 01 E 005 810 000 000 410	19.80
90112192	4TH BLANKET PO FOR FISCAL YEAR 2025-2026	04/17/2026	1,053.12		
				CUSTODIAL SUPPLIES-OPERATIONS-- 01 E 005 810 000 000 410	1,053.12

## Board Packet

AP Run: CB261004 — Post Date: 2026-04-28 — AP Run Type: R

Austin Public Schools ISD 492

Check Date	Check Number	Payment Type	Name			Check Amount
04/28/2026	5000002782		HILLYARD/HUTCHINSON*			12,538.44
<b>Invoice Number</b>	<b>Description</b>	<b>Invoice Date</b>	<b>Invoice Amount</b>	<b>Account</b>	<b>Amount</b>	
90112193	4TH BLANKET PO FOR FISCAL YEAR 2025-2026	04/17/2026	737.32			
				CUSTODIAL SUPPLIES-OPERATIONS-- 01 E 005 810 000 000 410	737.32	
90112194	4TH BLANKET PO FOR FISCAL YEAR 2025-2026	04/17/2026	218.50			
				CUSTODIAL SUPPLIES-OPERATIONS-- 01 E 005 810 000 000 410	218.50	
04/28/2026	5000002783		INNOVATIVE OFFICE SOLUTIONS, LLC*			287.73
<b>Invoice Number</b>	<b>Description</b>	<b>Invoice Date</b>	<b>Invoice Amount</b>	<b>Account</b>	<b>Amount</b>	
IN5099110	CHAIR FOR NURSE	04/14/2026	287.73			
				GEN SUPPLIES-ELEM ED-- 01 E 155 203 000 000 401	287.73	
04/28/2026	5000002784		JOSTEN'S*			13.05
<b>Invoice Number</b>	<b>Description</b>	<b>Invoice Date</b>	<b>Invoice Amount</b>	<b>Account</b>	<b>Amount</b>	
39088120	SIGNATURE CUT FOR DIPLOMAS	03/04/2026	13.05			
				GENERAL SUPPLIES-SECONDARY-GRADUATION- 01 E 310 211 815 000 401	13.05	
04/28/2026	5000002785		LAKESHORE LEARNING MATERIALS*			1,091.36
<b>Invoice Number</b>	<b>Description</b>	<b>Invoice Date</b>	<b>Invoice Amount</b>	<b>Account</b>	<b>Amount</b>	
93679556	EL SUPPLIES	04/12/2026	233.63			
				INSTRUCTL SUPPLIES-LEP--COMPENS 01 E 125 219 000 317 430	233.63	
93679558	THEOBALD-ML INSTRUCTIONAL SUPPLIES	04/12/2026	49.99			
				INSTRUCTL SUPPLIES-LEP--COMPENS 01 E 105 219 000 317 430	49.99	
93710737	THEOBALD-ML INSTRUCTIONAL SUPPLIES	04/19/2026	807.74			
				INSTRUCTL SUPPLIES-LEP--COMPENS 01 E 105 219 000 317 430	807.74	
04/28/2026	5000002786		REALLY GOOD STUFF INC*			65.97
<b>Invoice Number</b>	<b>Description</b>	<b>Invoice Date</b>	<b>Invoice Amount</b>	<b>Account</b>	<b>Amount</b>	
9172281	INSTRUCTIONAL SUPPLIES-N. EDWARDS	04/13/2026	65.97			
				INSTRUCTL SUPPLIES-ELEM ED-- 01 E 105 203 000 000 430	65.97	

## Board Packet

AP Run: CB261004 — Post Date: 2026-04-28 — AP Run Type: R

Austin Public Schools ISD 492

Check Date	Check Number	Payment Type	Name	Check Amount	
04/28/2026	5000002787		SCHOLASTIC BOOK FAIRS*	869.88	
<b>Invoice Number</b>	<b>Description</b>	<b>Invoice Date</b>	<b>Invoice Amount</b>	<b>Account</b>	<b>Amount</b>
W6083957BF	ELLIS MIDDLE SCHOOL BOOK FAIR ACCT #32772	04/15/2026	869.88		
			GEN SUPPLIES-ELLIS GENERAL-ELLIS-ELLIS GEN	11 E 210 120 030 120 401	869.88
04/28/2026	5000002788		SCHOOL HEALTH CORPORATION*	1,648.34	
<b>Invoice Number</b>	<b>Description</b>	<b>Invoice Date</b>	<b>Invoice Amount</b>	<b>Account</b>	<b>Amount</b>
CINV000374377	HEALTH SUPPLIES	03/27/2026	1,422.34		
			GEN SUPPLIES-HEALTH SVCS-	01 E 005 720 000 000 401	1,422.34
CINV000379809	HEALTH SUPPLIES	04/10/2026	226.00		
			GEN SUPPLIES-HEALTH SVCS-	01 E 005 720 000 000 401	226.00
<b>Total:</b>					<b>\$22,105.26</b>

### CB261004 Summary

Type	Count	Amount
Regular	0	0.00
ACH Checks:	0	0.00
Wire Transfers:	0	0.00
Epayables:	11	22,105.26
<b>Total:</b>	<b>11</b>	<b>\$22,105.26</b>

## Board Packet

AP Run: W261006 — Post Date: 2026-04-22 — AP Run Type: R

Austin Public Schools ISD 492

Check Date	Check Number	Payment Type	Name	Check Amount	
04/22/2026	202003795	Wire Transfer	ARBITOR SPORTS	8,314.00	
Invoice Number	Description	Invoice Date	Invoice Amount	Account	Amount
042226	SPRING 25-26 ARBITOR PAY FUNDING	04/22/2026	8,314.00		
	FEEES FOR SERVICES-BOY/GIRL--			01 E 210 292 000 000 305	1,860.00
	FEEES FOR SERVICES-BOY/GIRL-ATHLETICS-			01 E 310 292 100 000 305	264.00
	FEEES FOR SERVICES-BOYS-BASEBALL-			01 E 310 294 101 000 305	3,070.00
	FEEES FOR SERVICES-BOYS-BASKETBALL-			01 E 310 294 102 000 305	-745.00
	FEEES FOR SERVICES-BOYS-HOCKEY-			01 E 310 294 107 000 305	-880.00
	FEEES FOR SERVICES-BOYS-SWIM & DIVE-			01 E 310 294 108 000 305	-580.00
	FEEES FOR SERVICES-BOYS-WRESTLING-			01 E 310 294 111 000 305	180.00
	CONSULT FEE/FEEES FOR SVCS-BOYS ATHL-VOLLEYBALL-			01 E 310 294 116 000 305	3,540.00
	FEEES FOR SERVICES-GIRLS-BASKETBALL-			01 E 310 296 102 000 305	-530.00
	FEEES FOR SERVICES-GIRLS-GYMNASTICS-			01 E 310 296 106 000 305	-135.00
	FEEES FOR SERVICES-GIRLS-HOCKEY-			01 E 310 296 107 000 305	-330.00
	FEEES FOR SERVICES-GIRLS-SOFTBALL-			01 E 310 296 115 000 305	2,110.00
	FEEES FOR SERVICES-BOY/GIRL--STATE/SCTN.GATE			11 E 310 292 000 161 305	490.00
<b>Total:</b>					<b>\$8,314.00</b>

### W261006 Summary

Type	Count	Amount
Regular	0	0.00
ACH Checks:	0	0.00
Wire Transfers:	1	8,314.00
Epayables:	0	0.00
<b>Total:</b>	<b>1</b>	<b>\$8,314.00</b>

## Board Packet

AP Run: 04/29/2026 VOID CK #60613 — Post Date: 2026-04-29 — AP Run Type: V

Austin Public Schools ISD 492

Check Date	Check Number	Payment Type	Name	Check Amount	
04/29/2026	60613	Check	VALLEYFAIR	-1,962.24	
Invoice Number	Description	Invoice Date	Invoice Amount	Account	Amount
031726	VALLEYFAIR TICKETS	03/17/2026	-1,962.24		
	ENTRY FEE/STDT TRVL ALLOW-OTH PUP SUP-REACH-			01 E 310 790 489 000 369	-1,962.24
<b>Total:</b>					<b>-\$1,962.24</b>

### 04/29/2026 VOID CK #60613 Summary

Type	Count	Amount
Regular	1	-1,962.24
ACH Checks:	0	0.00
Wire Transfers:	0	0.00
Epayables:	0	0.00
<b>Total:</b>	<b>1</b>	<b>-\$1,962.24</b>

## Board Packet

AP Run: 5/1/2026 PR AP LI — Post Date: 2026-05-01 — AP Run Type: R

Austin Public Schools ISD 492

Check Date	Check Number	Payment Type	Name	Check Amount		
05/01/2026	202003796	Wire Transfer	MINNESOTA DEPT OF REVENUE	43.55		
<b>Invoice Number</b>	<b>Description</b>		<b>Invoice Date</b>	<b>Invoice Amount</b>	<b>Account</b>	<b>Amount</b>
MN.04282026.D	MN - MN STATE TAX for 4/28/2026 LI		04/28/2026	43.55		
			PAYROLL W/HOLDINGS-STATE WITHHOLDING		01 L 215 02	43.55
05/01/2026	202003797	Wire Transfer	UNITED STATES TREASURY	200.36		
<b>Invoice Number</b>	<b>Description</b>		<b>Invoice Date</b>	<b>Invoice Amount</b>	<b>Account</b>	<b>Amount</b>
FED.04282026.D	FED - FED TAX for 4/28/2026 LI		04/28/2026	37.56		
			PAYROLL W/HOLDINGS-FEDERAL WITHHOLDINGS		01 L 215 01	37.56
FIC.04282026.B	FIC - FICA for 4/28/2026 LI		04/28/2026	65.97		
			PAYROLL W/HOLDINGS-FEDERAL WITHHOLDINGS		01 L 215 01	65.97
FIC.04282026.D	FIC - FICA for 4/28/2026 LI		04/28/2026	65.97		
			PAYROLL W/HOLDINGS-FEDERAL WITHHOLDINGS		01 L 215 01	65.97
MED.04282026.B	MED - MEDICARE-1 for 4/28/2026 LI		04/28/2026	15.43		
			PAYROLL W/HOLDINGS-FEDERAL WITHHOLDINGS		01 L 215 01	15.43
MED.04282026.D	MED - MEDICARE1 for 4/28/2026 LI		04/28/2026	15.43		
			PAYROLL W/HOLDINGS-FEDERAL WITHHOLDINGS		01 L 215 01	15.43
<b>Total:</b>						<b>\$243.91</b>

### 5/1/2026 PR AP LI Summary

Type	Count	Amount
Regular	0	0.00
ACH Checks:	0	0.00
Wire Transfers:	2	243.91
Epayables:	0	0.00
<b>Total:</b>	<b>2</b>	<b>\$243.91</b>

## Board Packet

AP Run: 5/1/2026 TRA PERA — Post Date: 2026-05-01 — AP Run Type: R

Austin Public Schools ISD 492

Check Date	Check Number	Payment Type	Name	Check Amount	
05/01/2026	202003798	Wire Transfer	MN TEACHERS RETIREMENT ASSN	240,238.20	
Invoice Number	Description	Invoice Date	Invoice Amount	Account	Amount
TRC.04232026.B	TRC - TRA COORD for 4/23/2026 Reg PR	04/23/2026	132,295.28		
				PAYROLL W/HOLDINGS-TRA PAYABLE 01 L 215 04	129,109.48
				PAYROLL W/HOLDING-TRA PAYABLE 04 L 215 04	2,680.59
				PAYROLL W/HOLDINGS-TRA PAYABLE 11 L 215 04	14.71
				PAYROLL W/HOLDINGS-TRA PAYABLE 12 L 215 04	490.50
TRC.04232026.D	TRC - TRA CORD for 4/23/2026 Reg PR	04/23/2026	107,885.93		
				PAYROLL W/HOLDINGS-TRA PAYABLE 01 L 215 04	105,287.91
				PAYROLL W/HOLDING-TRA PAYABLE 04 L 215 04	2,186.02
				PAYROLL W/HOLDINGS-TRA PAYABLE 11 L 215 04	12.00
				PAYROLL W/HOLDINGS-TRA PAYABLE 12 L 215 04	400.00
TRC.04242026.B	TRC - TRA COORD for 4/24/2026 Extra PR	04/24/2026	31.39		
				PAYROLL W/HOLDINGS-TRA PAYABLE 01 L 215 04	31.39
TRC.04242026.D	TRC - TRA CORD for 4/24/2026 Extra PR	04/24/2026	25.60		
				PAYROLL W/HOLDINGS-TRA PAYABLE 01 L 215 04	25.60
05/01/2026	202003799	Wire Transfer	PUBLIC EMPLOYEES RETIREMENT ASSN	78,102.57	
Invoice Number	Description	Invoice Date	Invoice Amount	Account	Amount
PE\$.04232026.B	PE\$ - PERA DOLLAR AMT for 4/23/2026 Reg PR	04/23/2026	-225.64		
				PAYROLL W/HOLDINGS-PERA PAYABLE 01 L 215 03	-225.64
PE\$.04232026.D	PE\$ - PERA AMOUNT for 4/23/2026 Reg PR	04/23/2026	-195.56		
				PAYROLL W/HOLDINGS-PERA PAYABLE 01 L 215 03	-195.56
PRC.04232026.B	PRC - PERA CORD for 4/23/2026 Reg PR	04/23/2026	41,661.84		
				PAYROLL W/HOLDINGS-PERA PAYABLE 01 L 215 03	34,014.25
				PAYROLL W/HOLDINGS-PERA PAYABLE 02 L 215 03	4,017.82
				PAYROLL W/HOLDING-PERA PAYABLE 04 L 215 03	3,291.16
				PAYROLL W/HOLDINGS-PERA PAYABLE 05 L 215 03	338.61
PRC.04232026.D	PRC - PERA CORD for 4/23/2026 Reg PR	04/23/2026	36,106.92		
				PAYROLL W/HOLDINGS-PERA PAYABLE 01 L 215 03	29,479.02
				PAYROLL W/HOLDINGS-PERA PAYABLE 02 L 215 03	3,482.13

## Board Packet

AP Run: 5/1/2026 TRA PERA — Post Date: 2026-05-01 — AP Run Type: R

Austin Public Schools ISD 492

Check Date	Check Number	Payment Type	Name	Check Amount	
05/01/2026	202003799	Wire Transfer	PUBLIC EMPLOYEES RETIREMENT ASSN	78,102.57	
Invoice Number	Description	Invoice Date	Invoice Amount	Account	Amount
				PAYROLL W/HOLDING-PERA PAYABLE 04 L 215 03	2,852.30
				PAYROLL W/HOLDINGS-PERA PAYABLE 05 L 215 03	293.47
PRC.04242026.B	PRC - PERA CORD for 4/24/2026 Extra PR	04/24/2026	324.67		
				PAYROLL W/HOLDINGS-PERA PAYABLE 01 L 215 03	297.17
				PAYROLL W/HOLDINGS-PERA PAYABLE 02 L 215 03	27.50
PRC.04242026.D	PRC - PERA CORD for 4/24/2026 Extra PR	04/24/2026	281.38		
				PAYROLL W/HOLDINGS-PERA PAYABLE 01 L 215 03	257.55
				PAYROLL W/HOLDINGS-PERA PAYABLE 02 L 215 03	23.83
PRC.04282026.B	PRC - PERA CORD for 4/28/2026 LI	04/28/2026	79.80		
				PAYROLL W/HOLDINGS-PERA PAYABLE 01 L 215 03	79.80
PRC.04282026.D	PRC - PERA CORD for 4/28/2026 LI	04/28/2026	69.16		
				PAYROLL W/HOLDINGS-PERA PAYABLE 01 L 215 03	69.16
<b>Total:</b>					<b>\$318,340.77</b>

### 5/1/2026 TRA PERA Summary

Type	Count	Amount
Regular	0	0.00
ACH Checks:	0	0.00
Wire Transfers:	2	318,340.77
Epayables:	0	0.00
<b>Total:</b>	<b>2</b>	<b>\$318,340.77</b>

## Board Packet

AP Run: CB261101 — Post Date: 2026-05-05 — AP Run Type: R

Austin Public Schools ISD 492

Check Date	Check Number	Payment Type	Name	Check Amount	
05/05/2026	5000002789		AUSTIN ELECTRIC*	8,490.00	
<b>Invoice Number</b>	<b>Description</b>	<b>Invoice Date</b>	<b>Invoice Amount</b>	<b>Account</b>	<b>Amount</b>
2501162	AUSTIN ELECTRIC - WORK FOR COOLER/FREEZER/TIME-CLOCK RELOCATION (CLC @ WOODSON)	04/17/2026	4,295.00		
			REPAIR & MAINT SVCS-FOOD SVC--NSLP	02 E 005 770 000 701 350	4,295.00
2501163	IJ HOLTON - ELECTRIC WORK FOR WARMER/COOLER RELOCATION	12/23/2025	4,195.00		
			REPAIR & MAINT SVCS-FOOD SVC--NSLP	02 E 005 770 000 701 350	4,195.00
05/05/2026	5000002790		AUSTIN NEWSPAPERS, INC*	56.32	
<b>Invoice Number</b>	<b>Description</b>	<b>Invoice Date</b>	<b>Invoice Amount</b>	<b>Account</b>	<b>Amount</b>
2117022	PUBLICATION OF LEGAL NOTICES AND JOINT PUBLICATION	04/21/2026	56.32		
			FEES FOR SERVICES-SCHOOL BOARD--	01 E 005 010 000 000 305	56.32
05/05/2026	5000002791		CUSTOM ALARM INC*	1,138.98	
<b>Invoice Number</b>	<b>Description</b>	<b>Invoice Date</b>	<b>Invoice Amount</b>	<b>Account</b>	<b>Amount</b>
636140	AHS ON SITE SERVICE	04/09/2026	185.00		
			REPAIR/MAINT-LTFM--FIRE SAFETY	05 E 005 865 000 363 350	185.00
636374	WOODSON - MONITORING	04/10/2026	232.08		
			REPAIR/MAINT-LTFM--FIRE SAFETY	05 E 005 865 000 363 350	232.08
638084	IJ HOLTON - LED STROBE INDOOR CEILING RED FIRE	04/20/2026	721.90		
			REPAIR/MAINT-LTFM--FIRE SAFETY	05 E 005 865 000 363 350	721.90
05/05/2026	5000002792		JW PEPPER & SON INC*	49.99	
<b>Invoice Number</b>	<b>Description</b>	<b>Invoice Date</b>	<b>Invoice Amount</b>	<b>Account</b>	<b>Amount</b>
368526351	BAND MUSIC	04/22/2026	24.99		
			INSTRUCTL SUPPLIES-MUSIC-AHS-BAND	11 E 310 258 040 132 430	24.99
368527599	BAND MUSIC	04/22/2026	25.00		
			INSTRUCTL SUPPLIES-MUSIC-AHS-BAND	11 E 310 258 040 132 430	25.00

## Board Packet

AP Run: CB261101 — Post Date: 2026-05-05 — AP Run Type: R

Austin Public Schools ISD 492

Check Date	Check Number	Payment Type	Name	Check Amount	
05/05/2026	5000002793		MIDTOWN AUTO CLINIC*	394.44	
Invoice Number	Description	Invoice Date	Invoice Amount	Account	Amount
103967	2024 TRANSIT - OIL CHANGE	04/08/2026	52.42		
				REPAIR & MAINT SVCS-OPERATIONS-- 01 E 005 810 000 000 350	52.42
104001	2012 FORD F-250 OIL CHANGE	04/08/2026	100.24		
				REPAIR & MAINT SVCS-OPERATIONS-- 01 E 005 810 000 000 350	100.24
104068	2018 TRANSIT - OIL CHANGE	04/15/2026	54.58		
				REPAIR & MAINT SVCS-OPERATIONS-- 01 E 005 810 000 000 350	54.58
104117	2016 DODGE CARAVAN - OIL CHANGE/REPAIRS	04/20/2026	187.20		
				REPAIR & MAINT SVCS-OPERATIONS-- 01 E 005 810 000 000 350	187.20
05/05/2026	5000002794		W W GRAINGER INC*	91.38	
Invoice Number	Description	Invoice Date	Invoice Amount	Account	Amount
9872570461	BLANKET PO FOR FISCAL YEAR 2025-2026	04/08/2026	25.68		
				REPAIR SUPPLIES-OPERATIONS-- 01 E 005 810 000 000 420	25.68
9890990360	BLANKET PO FOR FISCAL YEAR 2025-2026	04/23/2026	65.70		
				REPAIR SUPPLIES-OPERATIONS-- 01 E 005 810 000 000 420	65.70
05/05/2026	5000002795		WEST MUSIC CO*	113.80	
Invoice Number	Description	Invoice Date	Invoice Amount	Account	Amount
SI2628450	INSTRUCTION BOOKS	04/06/2026	113.80		
				INSTRUCTL SUPPLIES-MUSIC-- 01 E 155 258 000 000 430	113.80
				<b>Total:</b>	<b>\$10,334.91</b>

### CB261101 Summary

Type	Count	Amount
Regular	0	0.00
ACH Checks:	0	0.00
Wire Transfers:	0	0.00
Epayables:	7	10,334.91
<b>Total:</b>	<b>7</b>	<b>\$10,334.91</b>

## Board Packet

AP Run: T261101 — Post Date: 2026-05-05 — AP Run Type: R

Austin Public Schools ISD 492

Check Date	Check Number	Payment Type	Name	Check Amount	
05/05/2026	60674	Check	ABDO	2,594.80	
<b>Invoice Number</b>	<b>Description</b>	<b>Invoice Date</b>	<b>Invoice Amount</b>	<b>Account</b>	<b>Amount</b>
0096091	BOOKS FOR LIBRARY - IMC SOUTHGATE	04/23/2026	2,594.80		
		LIBRARY BOOKS-MEDIA CENTER--		01 E 145 620 000 000 470	2,594.80
05/05/2026	60675	Check	ADORAMA INC	174.96	
<b>Invoice Number</b>	<b>Description</b>	<b>Invoice Date</b>	<b>Invoice Amount</b>	<b>Account</b>	<b>Amount</b>
38193674	CLASS SUPPLIES	04/10/2026	174.96		
		INSTRUCTL SUPPLIES-ART--		01 E 310 212 000 000 430	174.96
05/05/2026	60676	Check	ALBERT LEA HIGH SCHOOL	200.00	
<b>Invoice Number</b>	<b>Description</b>	<b>Invoice Date</b>	<b>Invoice Amount</b>	<b>Account</b>	<b>Amount</b>
040826-B	BOYS TRACK	04/08/2026	100.00		
		ENTRY FEES/STDT TRVL-BOYS ATHL-TRACK & FIELD-		01 E 310 294 110 000 369	100.00
040826-G	GIRLS TRACK	04/08/2026	100.00		
		ENTRY FEES/STDT TRAVL-GIRLS ATHL-TRACK & FIELD-		01 E 310 296 110 000 369	100.00
05/05/2026	60677	Check	ALMS, SHARON A	44.17	
<b>Invoice Number</b>	<b>Description</b>	<b>Invoice Date</b>	<b>Invoice Amount</b>	<b>Account</b>	<b>Amount</b>
0909-4718-7056-2604-2703	WALGREENS REIM	04/27/2026	11.22		
		GEN SUPPLIES-SCHOOL BOARD--		01 E 005 010 000 000 401	11.22
111-0595506-5295454	AMAZON REIM	04/21/2026	32.95		
		GEN SUPPLIES-SCHOOL BOARD--		01 E 005 010 000 000 401	32.95
05/05/2026	60678	Check	AMAZON BUSINESS	8,808.88	
<b>Invoice Number</b>	<b>Description</b>	<b>Invoice Date</b>	<b>Invoice Amount</b>	<b>Account</b>	<b>Amount</b>
114T-1D1M-G9HG	GRANT MUSIC SUPPLES/OFFICE SUPPLIES	04/24/2026	195.34		
		GENERAL SUPPLIES-GEN SPED-SMIF GRANT-		01 E 120 400 095 000 401	129.91
		GEN SUPPLIES-ECFE--ECFE		04 E 500 580 000 325 401	65.43
11LW-XCFX-XM1V	CLASSROOM SUPPLY	04/24/2026	124.99		
		GEN SUPPLIES-ECSE--IDEA SEC 619		01 E 120 412 000 420 401	124.99

## Board Packet

AP Run: T261101 — Post Date: 2026-05-05 — AP Run Type: R

Austin Public Schools ISD 492

Check Date	Check Number	Payment Type	Name	Check Amount	
05/05/2026	60678	Check	AMAZON BUSINESS	8,808.88	
Invoice Number	Description	Invoice Date	Invoice Amount	Account	Amount
14FD-1NPY-43D9	CARTS FOR VIEWBOARDS	04/22/2026	830.97		
		INST TECH SUPPLIES-ELEM ED--		01 E 155 203 000 000 456	830.97
169K-N6RD-3JMY	SUPPLIES	04/29/2026	487.20		
		GEN SUPPLIES-ADM TECH SRV--		01 E 005 108 000 000 401	487.20
173C-NDPG-C6JN	MICKEY SMITH-GENERAL SUPPLIES	04/13/2026	140.64		
		GEN SUPPLIES-ELEM ED--		01 E 105 203 000 000 401	140.64
177F-LNH3-RRM3	PT SUPPLY	04/20/2026	9.78		
		GEN SUPPLIES-SPED AGG--IDEA-611		01 E 005 420 000 419 401	9.78
17RJ-NLC9-9DC4	CLASSROOM MATERIALS	04/26/2026	434.73		
		INDIV INST SUPPLIES-ASD--IDEA SEC 619		01 E 120 411 000 420 433	205.58
		INDIV INST SUPPLIES-ECSE--IDEA SEC 619		01 E 120 412 000 420 433	183.78
		INDIV INST SUPPLIES-ASD--STATE SPED		01 E 155 411 000 740 433	45.37
19P1-93WQ-JTLN	ATHLETIC OFFICE SUPPLIES	04/29/2026	99.89		
		GEN SUPPLIES-BOY/GIRL-ATHLETICS-		01 E 310 292 100 000 401	99.89
1HCP-3QT4-DCFH	CLASSROOM MATERIALS	04/28/2026	28.82		
		INDIV INST SUPPLIES-ASD--IDEA SEC 619		01 E 120 411 000 420 433	14.41
		INDIV INST SUPPLIES-ECSE--IDEA SEC 619		01 E 120 412 000 420 433	12.97
		INDIV INST SUPPLIES-ASD--STATE SPED		01 E 155 411 000 740 433	1.44
1HKD-XNCJ-7QXW	ATHLETIC OFFICE SUPPLIES	04/29/2026	554.16		
		GEN SUPPLIES-BOY/GIRL-ATHLETICS-		01 E 310 292 100 000 401	554.16
1L9G-7GFJ-C7CP	TV STANDS, INDEX CARDS, DRY ERASE SLEEVES	04/28/2026	242.99		
		GEN SUPPLIES-ELEM ED--		01 E 105 203 000 000 401	242.99
1M14-411R-9NP1	STUDENT ACADEMIC ENRICHMENT MATERIALS	04/29/2026	3,047.58		
		TEXTBK/WKBK-STU DUP/ENRICH--TITLE IV-A		01 E 005 206 000 433 460	3,047.58
1NPJ-1D63-DKDD	ML SUPPLIES	04/21/2026	55.34		
		INSTRUCTL SUPPLIES-LEP--COMPENS		01 E 105 219 000 317 430	55.34
1PLP-JRT7-WM6J	SUPPLIES	04/24/2026	114.03		
		GEN SUPPLIES-ECFE--ECFE		04 E 500 580 000 325 401	114.03

## Board Packet

AP Run: T261101 — Post Date: 2026-05-05 — AP Run Type: R

Austin Public Schools ISD 492

Check Date	Check Number	Payment Type	Name	Check Amount
05/05/2026	60678	Check	AMAZON BUSINESS	8,808.88
<b>Invoice Number</b>	<b>Description</b>	<b>Invoice Date</b>	<b>Invoice Amount</b>	<b>Account</b>
1TLW-GLJJ-GMFL	N. EDWARDS-GENERAL SUPPLIES	04/22/2026	228.55	
		INSTRUCTL SUPPLIES-ELEM ED--		01 E 105 203 000 000 430
			228.55	
1VV6-YN71-DXQJ	MICKEY SMITH-GENERAL SUPPLIES	04/30/2026	14.97	
		GEN SUPPLIES-ELEM ED--		01 E 105 203 000 000 401
			14.97	
1Y47-KCCH-3VFX	TV STANDS, INDEX CARDS, DRY ERASE SLEEVES	04/28/2026	556.71	
		GEN SUPPLIES-ELEM ED--		01 E 105 203 000 000 401
			252.99	
		INSTRUCTL SUPPLIES-ELEM ED--		01 E 105 203 000 000 430
			303.72	
1YPD-RTT1-3QC6	SUPPLIES	04/22/2026	1,642.19	
		GEN SUPPLIES-ADM TECH SRV--		01 E 005 108 000 000 401
			1,642.19	
05/05/2026	60679	Check	ANDERSEN, STACY	38.40
<b>Invoice Number</b>	<b>Description</b>	<b>Invoice Date</b>	<b>Invoice Amount</b>	<b>Account</b>
042926	INDISTRICT MILEAGE REIM - APR 26	04/29/2026	38.40	
		TRAVEL CONV & CONF-ECFE--ECFE		04 E 500 580 000 325 366
			38.40	
05/05/2026	60680	Check	ANFINSON, PAMELA M	30.81
<b>Invoice Number</b>	<b>Description</b>	<b>Invoice Date</b>	<b>Invoice Amount</b>	<b>Account</b>
043026	INDISTRICT MILEAGE REIM APR 26	04/30/2026	30.81	
		IN-DISTRICT TRAVEL-SPED AGG--IDEA-611		01 E 005 420 000 419 367
			30.81	
05/05/2026	60681	Check	AUSTIN FIRE AND SAFETY CO	300.00
<b>Invoice Number</b>	<b>Description</b>	<b>Invoice Date</b>	<b>Invoice Amount</b>	<b>Account</b>
0044491	ANNUAL SERVICES FY 2025-2026	04/16/2026	300.00	
		REPAIR/MAINT-LTFM--FIRE SAFETY		05 E 005 865 000 363 350
			300.00	
05/05/2026	60682	Check	AUSTIN UTILITIES	130,074.46
<b>Invoice Number</b>	<b>Description</b>	<b>Invoice Date</b>	<b>Invoice Amount</b>	<b>Account</b>
APRIL 2026	2025-2026 UTILITIES	04/27/2026	130,074.46	
		UTILITIES-OPERATIONS--		01 E 005 810 000 000 330
			82.77	
		WATER-OPERATIONS--		01 E 005 810 000 000 333
			384.85	
		FUELS-OPERATIONS--		01 E 005 810 000 000 440
			1,228.18	

## Board Packet

AP Run: T261101 — Post Date: 2026-05-05 — AP Run Type: R

Austin Public Schools ISD 492

Check Date	Check Number	Payment Type	Name	Check Amount
05/05/2026	60682	Check	AUSTIN UTILITIES	130,074.46

Invoice Number	Description	Invoice Date	Invoice Amount	Account	Amount
	UTILITIES-OPERATIONS--	01 E 105 810 000 000 330			7,112.52
	WATER-OPERATIONS--	01 E 105 810 000 000 333			962.59
	FUELS-OPERATIONS--	01 E 105 810 000 000 440			4,335.98
	UTILITIES-OPERATIONS--	01 E 120 810 000 000 330			1,376.54
	WATER-OPERATIONS--	01 E 120 810 000 000 333			185.76
	FUELS-OPERATIONS--	01 E 120 810 000 000 440			895.03
	UTILITIES-OPERATIONS--	01 E 125 810 000 000 330			3,452.95
	WATER-OPERATIONS--	01 E 125 810 000 000 333			739.39
	FUELS-OPERATIONS--	01 E 125 810 000 000 440			1,883.17
	UTILITIES-OPERATIONS--	01 E 145 810 000 000 330			4,915.90
	WATER-OPERATIONS--	01 E 145 810 000 000 333			1,095.10
	FUELS-OPERATIONS--	01 E 145 810 000 000 440			2,542.08
	UTILITIES-OPERATIONS--	01 E 155 810 000 000 330			3,671.75
	WATER-OPERATIONS--	01 E 155 810 000 000 333			702.38
	FUELS-OPERATIONS--	01 E 155 810 000 000 440			1,937.55
	UTILITIES-OPERATIONS--	01 E 185 810 000 000 330			12,948.93
	WATER-OPERATIONS--	01 E 185 810 000 000 333			1,006.69
	FUELS-OPERATIONS--	01 E 185 810 000 000 440			1,820.01
	UTILITIES-OPERATIONS--	01 E 210 810 000 000 330			12,599.03
	WATER-OPERATIONS--	01 E 210 810 000 000 333			1,802.94
	FUELS-OPERATIONS--	01 E 210 810 000 000 440			8,018.82
	UTILITIES-OPERATIONS--	01 E 310 810 000 000 330			25,805.74
	WATER-OPERATIONS--	01 E 310 810 000 000 333			2,665.17
	FUELS-OPERATIONS--	01 E 310 810 000 000 440			8,462.16
	UTILITIES-OPERATIONS--	01 E 311 810 000 000 330			5,985.70
	FUELS-OPERATIONS--	01 E 311 810 000 000 440			8,997.45
	UTILITIES-OTH COM PRG--COM ED	04 E 500 590 000 321 330			1,376.54
	WATER-OTH COM PRG--COM ED	04 E 500 590 000 321 333			185.76

## Board Packet

AP Run: T261101 — Post Date: 2026-05-05 — AP Run Type: R

Austin Public Schools ISD 492

Check Date	Check Number	Payment Type	Name	Check Amount		
05/05/2026	60682	Check	AUSTIN UTILITIES	130,074.46		
<u>Invoice Number</u>	<u>Description</u>		<u>Invoice Date</u>	<u>Invoice Amount</u>	<u>Account</u>	<u>Amount</u>
			FUEL FOR BLDGS-OTH COM PRG--COM ED	04 E 500 590 000 321 440		895.03
05/05/2026	60683	Check	AVIBEN LLC	590.82		
<u>Invoice Number</u>	<u>Description</u>		<u>Invoice Date</u>	<u>Invoice Amount</u>	<u>Account</u>	<u>Amount</u>
41179	403(B) ADMIN & COMPLIANCE SERVICE MONTHLY FEE		03/01/2026	295.41		
			FEEES FOR SERVICES-BUSINESS OFFICE--		01 E 005 110 000 000 305	295.41
41989	403(B) ADMIN & COMPLIANCE SERVICE MONTHLY FEE		05/01/2026	295.41		
			FEEES FOR SERVICES-BUSINESS OFFICE--		01 E 005 110 000 000 305	295.41
05/05/2026	60684	Check	BJOREM SPEECH	121.64		
<u>Invoice Number</u>	<u>Description</u>		<u>Invoice Date</u>	<u>Invoice Amount</u>	<u>Account</u>	<u>Amount</u>
123776	SPEECH MATERIAL		04/20/2026	121.64		
			INDIV INST SUPPLIES-SPEECH--STATE SPED		01 E 145 401 000 740 433	121.64
05/05/2026	60685	Check	BORDELON, BRANDI L	407.51		
<u>Invoice Number</u>	<u>Description</u>		<u>Invoice Date</u>	<u>Invoice Amount</u>	<u>Account</u>	<u>Amount</u>
015517	CULVERS LUNCH REIM - MCTM CONF		04/25/2026	14.44		
			TRAVEL CONV & CONF-CURRICULUM--STAFF DEV		01 E 005 610 000 316 366	14.44
042326	MILEAGE REIM - MCTM CONF		04/23/2026	181.25		
			TRAVEL CONV & CONF-CURRICULUM--STAFF DEV		01 E 005 610 000 316 366	181.25
042526	MILEAGE REIM - MCTM CONF		04/25/2026	181.25		
			TRAVEL CONV & CONF-CURRICULUM--STAFF DEV		01 E 005 610 000 316 366	181.25
131746	LITTLE ANGIES DINNER REIM - MCTM CONF		04/24/2026	17.57		
			TRAVEL CONV & CONF-CURRICULUM--STAFF DEV		01 E 005 610 000 316 366	17.57
684461	STARBUCKS BREAKFAST REIM - MCTM CONF		04/24/2026	13.00		
			TRAVEL CONV & CONF-CURRICULUM--STAFF DEV		01 E 005 610 000 316 366	13.00
05/05/2026	60686	Check	BROWN, DAVID C	167.57		
<u>Invoice Number</u>	<u>Description</u>		<u>Invoice Date</u>	<u>Invoice Amount</u>	<u>Account</u>	<u>Amount</u>
UF0JNY633164	SAMS CLUB REIM		04/18/2026	167.57		
			FOOD-BOY/GIRL-ATHLETICS-		01 E 310 292 100 000 490	167.57

## Board Packet

AP Run: T261101 — Post Date: 2026-05-05 — AP Run Type: R

Austin Public Schools ISD 492

Check Date	Check Number	Payment Type	Name	Check Amount		
05/05/2026	60687	Check	CANNON, MACEY	24.08		
<u>Invoice Number</u>	<u>Description</u>		<u>Invoice Date</u>	<u>Invoice Amount</u>	<u>Account</u>	<u>Amount</u>
040926	SENIOR PARKING LOT REIM		04/09/2026	24.08		
			GEN SUPPLIES-SEC-AHS-POP/VENDING		11 E 310 211 040 100 401	24.08
05/05/2026	60688	Check	CHASKA HIGH SCHOOL	225.00		
<u>Invoice Number</u>	<u>Description</u>		<u>Invoice Date</u>	<u>Invoice Amount</u>	<u>Account</u>	<u>Amount</u>
042726	GIRLS GOLF		04/27/2026	225.00		
			ENTRY FEES/STDT TRVL-GIRLS ATHL-GOLF-		01 E 310 296 114 000 369	225.00
05/05/2026	60689	Check	CHRISTIAN, LINDSEY N	188.01		
<u>Invoice Number</u>	<u>Description</u>		<u>Invoice Date</u>	<u>Invoice Amount</u>	<u>Account</u>	<u>Amount</u>
113-5555198-4623459	AMAZON REIM		04/24/2026	188.01		
			INSTRUCTIONAL SUP-ECFE--ECFE		04 E 500 580 000 325 430	188.01
05/05/2026	60690	Check	CITY OF AUSTIN	243.75		
<u>Invoice Number</u>	<u>Description</u>		<u>Invoice Date</u>	<u>Invoice Amount</u>	<u>Account</u>	<u>Amount</u>
22378	RIVERSIDE ICE TIME - MARCH 2026		04/17/2026	243.75		
			SHORT TERM LEASE/RENTAL-CAP FAC-ATHLETICS-OPER CAP		05 E 005 850 100 302 335	243.75
05/05/2026	60691	Check	CLINE, JULIA	599.99		
<u>Invoice Number</u>	<u>Description</u>		<u>Invoice Date</u>	<u>Invoice Amount</u>	<u>Account</u>	<u>Amount</u>
023220944224792529380	CEO - AMAZON REIM		04/14/2026	218.11		
			GEN SUPPLIES-SEC-CEO PROGRAM-		01 E 310 211 206 000 401	218.11
07777112575024422617	CEO - WALMART REIM		03/23/2026	28.65		
			GEN SUPPLIES-SEC-CEO PROGRAM-		01 E 310 211 206 000 401	28.65
0870001070660414262	CEO - HOBBY LOBBY REIM		04/14/2026	49.51		
			GEN SUPPLIES-SEC-CEO PROGRAM-		01 E 310 211 206 000 401	49.51
114-1103348-2569810	CEO - AMAZON REIM		03/12/2026	8.62		
			GEN SUPPLIES-SEC-CEO PROGRAM-		01 E 310 211 206 000 401	8.62

## Board Packet

AP Run: T261101 — Post Date: 2026-05-05 — AP Run Type: R

Austin Public Schools ISD 492

Check Date	Check Number	Payment Type	Name	Check Amount	
05/05/2026	60691	Check	CLINE, JULIA	599.99	
Invoice Number	Description	Invoice Date	Invoice Amount	Account	Amount
114-4769403-6746652	CEO - AMAZON REIM	04/14/2026	20.84		
				GEN SUPPLIES-SEC-CEO PROGRAM- 01 E 310 211 206 000 401	20.84
114-5818967-6949049	CEO - AMAZON REIM	03/11/2026	166.38		
				GEN SUPPLIES-SEC-CEO PROGRAM- 01 E 310 211 206 000 401	166.38
114-7808208-4453858	CEO - AMAZON REIM	03/30/2026	20.99		
				GEN SUPPLIES-SEC-CEO PROGRAM- 01 E 310 211 206 000 401	20.99
114-9637576-7968237	CEO - AMAZON REIM	04/06/2026	36.64		
				GEN SUPPLIES-SEC-CEO PROGRAM- 01 E 310 211 206 000 401	36.64
26043983010688719963	CEO - WALMART REIM	03/08/2026	7.16		
				GEN SUPPLIES-SEC-CEO PROGRAM- 01 E 310 211 206 000 401	7.16
66788796784100252488	CEO - WALMART REIM	04/13/2026	12.96		
				GEN SUPPLIES-SEC-CEO PROGRAM- 01 E 310 211 206 000 401	12.96
INVUS20260330002598917	CEO - SHEIN REIM	03/30/2026	30.13		
				GEN SUPPLIES-SEC-CEO PROGRAM- 01 E 310 211 206 000 401	30.13
05/05/2026	60692	Check	COON RAPIDS HIGH SCHOOL	300.00	
Invoice Number	Description	Invoice Date	Invoice Amount	Account	Amount
040926	BOYS GOLF	04/09/2026	300.00		
				ENTRY FEES/STDT TRVL-BOYS ATHL-GOLF- 01 E 310 294 114 000 369	300.00
05/05/2026	60693	Check	D & G ACE HARDWARE	499.97	
Invoice Number	Description	Invoice Date	Invoice Amount	Account	Amount
146050/1	BLANKET PO FOR CLASS SUPPLIES	04/13/2026	111.91		
				INDIV INST SUPPLIES-TRAD/IND-WOOD/ELEC.-CTE 01 E 310 361 863 817 433	111.91

## Board Packet

AP Run: T261101 — Post Date: 2026-05-05 — AP Run Type: R

Austin Public Schools ISD 492

Check Date	Check Number	Payment Type	Name	Check Amount	
05/05/2026	60693	Check	D & G ACE HARDWARE	499.97	
Invoice Number	Description	Invoice Date	Invoice Amount	Account	Amount
146051/1	BLANKET PO FOR CLASS SUPPLIES	04/13/2026	64.99		
	INDIV INST SUPPLIES-TRAD/IND-WOOD/ELEC.-CTE			01 E 310 361 863 817 433	64.99
146055/1	2ND BLANKET PO FOR FISCAL YEAR 2025-2026	04/14/2026	79.98		
	REPAIR SUPPLIES-OPERATIONS--			01 E 005 810 000 000 420	79.98
146092/1	2ND BLANKET PO FOR FISCAL YEAR 2025-2026	04/15/2026	19.96		
	REPAIR SUPPLIES-OPERATIONS--			01 E 005 810 000 000 420	19.96
146102/1	BLANKET PO FOR CLASS SUPPLIES	04/15/2026	44.99		
	INDIV INST SUPPLIES-TRAD/IND-WOOD/ELEC.-CTE			01 E 310 361 863 817 433	44.99
146122/1	2ND BLANKET PO FOR FISCAL YEAR 2025-2026	04/16/2026	33.40		
	REPAIR SUPPLIES-OPERATIONS--			01 E 005 810 000 000 420	33.40
146125/1	2ND BLANKET PO FOR FISCAL YEAR 2025-2026	04/16/2026	10.98		
	REPAIR SUPPLIES-OPERATIONS--			01 E 005 810 000 000 420	10.98
146144/1	2ND BLANKET PO FOR FISCAL YEAR 2025-2026	04/17/2026	2.99		
	REPAIR SUPPLIES-OPERATIONS--			01 E 005 810 000 000 420	2.99
146155/1	BLANKET PO FOR CLASS SUPPLIES	04/17/2026	58.63		
	INDIV INST SUPPLIES-TRAD/IND-WOOD/ELEC.-CTE			01 E 310 361 863 817 433	58.63
146191/1	2ND BLANKET PO FOR FISCAL YEAR 2025-2026	04/21/2026	26.92		
	REPAIR SUPPLIES-OPERATIONS--			01 E 005 810 000 000 420	26.92
146203/1	2ND BLANKET PO FOR FISCAL YEAR 2025-2026	04/22/2026	25.98		
	REPAIR SUPPLIES-OPERATIONS--			01 E 005 810 000 000 420	25.98
146205/1	2ND BLANKET PO FOR FISCAL YEAR 2025-2026	04/22/2026	14.16		
	REPAIR SUPPLIES-OPERATIONS--			01 E 005 810 000 000 420	14.16
146253/1	BLANKET PO FOR CLASS SUPPLIES	04/23/2026	5.08		
	INDIV INST SUPPLIES-TRAD/IND-WOOD/ELEC.-CTE			01 E 310 361 863 817 433	5.08
05/05/2026	60694	Check	DUNDAS, CHRISTOPH S	297.07	
Invoice Number	Description	Invoice Date	Invoice Amount	Account	Amount
10633642	ACOUSTIC CAFE REIM	04/18/2026	176.14		
	FOOD-MUSIC-AHS-BAND			11 E 310 258 040 132 490	176.14

## Board Packet

AP Run: T261101 — Post Date: 2026-05-05 — AP Run Type: R

Austin Public Schools ISD 492

Check Date	Check Number	Payment Type	Name	Check Amount	
05/05/2026	60694	Check	DUNDAS, CHRISTOPH S	297.07	
<b>Invoice Number</b>	<b>Description</b>	<b>Invoice Date</b>	<b>Invoice Amount</b>	<b>Account</b>	<b>Amount</b>
38549-1	GEORGE'S VINEYARD REIM	04/22/2026	120.93		
			FOOD-MUSIC-AHS-BAND	11 E 310 258 040 132 490	120.93
05/05/2026	60695	Check	EBELING, CHRISTINA	62.32	
<b>Invoice Number</b>	<b>Description</b>	<b>Invoice Date</b>	<b>Invoice Amount</b>	<b>Account</b>	<b>Amount</b>
741981011	ORIENTAL TRADING REIM	04/22/2026	62.32		
			INDIV INST SUPPLIES-AGRI-FARM OPER-CTE	01 E 310 301 501 801 433	62.32
05/05/2026	60696	Check	EDWARDS, NICOLE M	392.07	
<b>Invoice Number</b>	<b>Description</b>	<b>Invoice Date</b>	<b>Invoice Amount</b>	<b>Account</b>	<b>Amount</b>
042326	MILEAGE REIM - MCTM CONF	04/23/2026	175.45		
			TRAVEL CONV & CONF-CURRICULUM--STAFF DEV	01 E 005 610 000 316 366	175.45
042526	MILEAGE REIM - MCTM CONF	04/25/2026	175.45		
			TRAVEL CONV & CONF-CURRICULUM--STAFF DEV	01 E 005 610 000 316 366	175.45
131746	LITTLE ANGIES DINNER REIM - MCTM CONF	04/24/2026	18.17		
			TRAVEL CONV & CONF-CURRICULUM--STAFF DEV	01 E 005 610 000 316 366	18.17
207599067	PARKING REIM - MCTM CONF	04/25/2026	10.00		
			TRAVEL CONV & CONF-CURRICULUM--STAFF DEV	01 E 005 610 000 316 366	10.00
682413	STARBUCKS BREAKFAST REIM - MCTM CONF	04/25/2026	13.00		
			TRAVEL CONV & CONF-CURRICULUM--STAFF DEV	01 E 005 610 000 316 366	13.00
05/05/2026	60697	Check	ELIZA OR JOHN KELLY	32.60	
<b>Invoice Number</b>	<b>Description</b>	<b>Invoice Date</b>	<b>Invoice Amount</b>	<b>Account</b>	<b>Amount</b>
050126	LUNCH MONEY STUDENT REFUND	05/01/2026	32.60		
			SALES TO PUPILS-FOOD SVC--TYPE A	02 R 005 770 000 701 601	32.60
05/05/2026	60698	Check	EO JOHNSON BUSINESS TECH	260.96	
<b>Invoice Number</b>	<b>Description</b>	<b>Invoice Date</b>	<b>Invoice Amount</b>	<b>Account</b>	<b>Amount</b>
INV1952480	FOOD SERVICE LOANER USAGE	04/28/2026	260.96		
			REPAIR & MAINT SVCS-FOOD SVC--NSLP	02 E 005 770 000 701 350	234.96
			PRINCIPAL ON CAP LEASE-FOOD SVC--NSLP	02 E 005 770 000 701 580	26.00

## Board Packet

AP Run: T261101 — Post Date: 2026-05-05 — AP Run Type: R

Austin Public Schools ISD 492

Check Date	Check Number	Payment Type	Name	Check Amount		
05/05/2026	60699	Check	ETS ROCHESTER LLC	4,500.00		
<u>Invoice Number</u>	<u>Description</u>		<u>Invoice Date</u>	<u>Invoice Amount</u>	<u>Account</u>	<u>Amount</u>
1067	ETS CONTRACT		05/01/2026	4,500.00		
			FEES FOR SERVICES-BOY/GIRL-ATHLETICS-		01 E 310 292 100 000 305	4,500.00
05/05/2026	60700	Check	EXCEL HONORS ORCHESTRA	80.00		
<u>Invoice Number</u>	<u>Description</u>		<u>Invoice Date</u>	<u>Invoice Amount</u>	<u>Account</u>	<u>Amount</u>
202602-2	EXCEL LATE REGISTRATION PAYMENTS		04/18/2026	80.00		
			STU TRV ALLOW/ENT FEE-MUSIC-ELLIS-ORCHESTRA		11 E 210 258 030 134 369	80.00
05/05/2026	60701	Check	FINLEY, FELICIA M	469.98		
<u>Invoice Number</u>	<u>Description</u>		<u>Invoice Date</u>	<u>Invoice Amount</u>	<u>Account</u>	<u>Amount</u>
042326	MILEAGE REIM - MCTM CONF		04/23/2026	188.86		
			TRAVEL CONV & CONF-CURRICULUM--STAFF DEV		01 E 005 610 000 316 366	188.86
042526	MILEAGE REIM - MCTM CONF		04/25/2026	188.86		
			TRAVEL CONV & CONF-CURRICULUM--STAFF DEV		01 E 005 610 000 316 366	188.86
131746	LITTLE ANGIES DINNER REIM - MCTM CONF		04/24/2026	21.67		
			TRAVEL CONV & CONF-CURRICULUM--STAFF DEV		01 E 005 610 000 316 366	21.67
13218467	KWIKTRIP LUNCH REIM - MCTM CONF		04/25/2026	9.20		
			TRAVEL CONV & CONF-CURRICULUM--STAFF DEV		01 E 005 610 000 316 366	9.20
207599525	PARKING REIM - MCTM CONF		04/25/2026	10.00		
			TRAVEL CONV & CONF-CURRICULUM--STAFF DEV		01 E 005 610 000 316 366	10.00
337219	GRANDMAS SALOON DINNER REIM - MCTM CONF		04/23/2026	25.39		
			TRAVEL CONV & CONF-CURRICULUM--STAFF DEV		01 E 005 610 000 316 366	25.39
682446	STARBUCKS BREAKFAST REIM - MCTM CONF		04/25/2026	13.00		
			TRAVEL CONV & CONF-CURRICULUM--STAFF DEV		01 E 005 610 000 316 366	13.00
684448	STARBUCKS BREAKFAST REIM - MCTM CONF		04/24/2026	13.00		
			TRAVEL CONV & CONF-CURRICULUM--STAFF DEV		01 E 005 610 000 316 366	13.00

## Board Packet

AP Run: T261101 — Post Date: 2026-05-05 — AP Run Type: R

Austin Public Schools ISD 492

Check Date	Check Number	Payment Type	Name	Check Amount		
05/05/2026	60702	Check	FLOOD, TALIAH	236.71		
<b>Invoice Number</b>	<b>Description</b>		<b>Invoice Date</b>	<b>Invoice Amount</b>	<b>Account</b>	<b>Amount</b>
113-0525918-3945011	CEO - AMAZON REIM		03/20/2026	8.52		
			GEN SUPPLIES-SEC-CEO PROGRAM-		01 E 310 211 206 000 401	8.52
113-1435435-3439435	CEO - AMAZON REIM		04/16/2026	155.37		
			GEN SUPPLIES-SEC-CEO PROGRAM-		01 E 310 211 206 000 401	155.37
113-7228513-0018623	CEO - AMAZON REIM		04/14/2026	40.92		
			GEN SUPPLIES-SEC-CEO PROGRAM-		01 E 310 211 206 000 401	40.92
113-8073770-1225830	CEO - AMAZON REIM		04/14/2026	31.90		
			GEN SUPPLIES-SEC-CEO PROGRAM-		01 E 310 211 206 000 401	31.90
05/05/2026	60703	Check	GIFTED UNLIMITED LLC	205.15		
<b>Invoice Number</b>	<b>Description</b>		<b>Invoice Date</b>	<b>Invoice Amount</b>	<b>Account</b>	<b>Amount</b>
2822	IOWA ACCELERATION SCALE FORMS		04/24/2026	205.15		
			INDIV INST SUPPLIES-GIFTED--GIFT/TA		01 E 005 218 000 388 433	205.15
05/05/2026	60704	Check	GOPHER SPORT	3,452.01		
<b>Invoice Number</b>	<b>Description</b>		<b>Invoice Date</b>	<b>Invoice Amount</b>	<b>Account</b>	<b>Amount</b>
IN507883	PE CLASSROOM SUPPLIES		04/09/2026	3,452.01		
			INSTRUCTL SUPPLIES-HLTH & PHY.ED.--		01 E 310 240 000 000 430	1,900.81
			INSTRUCTIONAL SUPPLIES-HEALTH/PE-MISC GRANTS-		01 E 310 240 804 000 430	1,551.20
05/05/2026	60705	Check	GREAT LAWN SERVICES, LLC	5,239.00		
<b>Invoice Number</b>	<b>Description</b>		<b>Invoice Date</b>	<b>Invoice Amount</b>	<b>Account</b>	<b>Amount</b>
17467	LAWN SERVICE		04/25/2026	4,375.00		
			FEES FOR SERVICES-OPERATIONS--		01 E 005 810 000 000 305	4,375.00
17470	LAWN SERVICE		04/26/2026	864.00		
			FEES FOR SERVICES-OPERATIONS--		01 E 005 810 000 000 305	864.00

## Board Packet

AP Run: T261101 — Post Date: 2026-05-05 — AP Run Type: R

Austin Public Schools ISD 492

Check Date	Check Number	Payment Type	Name	Check Amount		
05/05/2026	60706	Check	GREATAMERICA FINANCIAL SERVICES	197.95		
<b>Invoice Number</b>	<b>Description</b>		<b>Invoice Date</b>	<b>Invoice Amount</b>	<b>Account</b>	<b>Amount</b>
41830100	MAIL MACHINE SERVICES 25-26		04/24/2026	197.95		
			POSTAGE & EXPRESS-BUSINESS OFFICE--		01 E 005 110 000 000 329	197.95
05/05/2026	60707	Check	HARDY GERANIUM	60.00		
<b>Invoice Number</b>	<b>Description</b>		<b>Invoice Date</b>	<b>Invoice Amount</b>	<b>Account</b>	<b>Amount</b>
057339	FLORAL DESIGN FLOWERS		04/08/2026	60.00		
			INDIV INST SUPPLIES-AGRI-FARM OPER-CTE		01 E 310 301 501 801 433	60.00
05/05/2026	60708	Check	HARTY MECHANICAL INC	17,013.34		
<b>Invoice Number</b>	<b>Description</b>		<b>Invoice Date</b>	<b>Invoice Amount</b>	<b>Account</b>	<b>Amount</b>
1025582	ELLIS - WALK-IN FREEZER REAPIR		02/13/2026	3,088.01		
			REPAIR & MAINT SVCS-FOOD SVC--NSLP		02 E 005 770 000 701 350	3,088.01
1025617	ELLIS - AHU REPAIR		04/17/2026	13,925.33		
			REPAIR & MAINT-LTFM--MECHANICAL SYSTEMS		05 E 005 865 000 380 350	13,925.33
05/05/2026	60709	Check	HAUGEN, COREY	168.20		
<b>Invoice Number</b>	<b>Description</b>		<b>Invoice Date</b>	<b>Invoice Amount</b>	<b>Account</b>	<b>Amount</b>
042426	MILEAGE REIM - INFINITE CAMPUS USER GROUP MTG		04/24/2026	168.20		
			TRAVEL/CONFERENCE-STAFF DEV-DIRECTOR HAUGEN, C		55 E 005 640 006 000 366	168.20
05/05/2026	60710	Check	HAYFIELD HIGH SCHOOL	300.00		
<b>Invoice Number</b>	<b>Description</b>		<b>Invoice Date</b>	<b>Invoice Amount</b>	<b>Account</b>	<b>Amount</b>
041126-B	BOYS GOLF		04/11/2026	150.00		
			ENTRY FEES/STDT TRVL-BOYS ATHL-GOLF-		01 E 310 294 114 000 369	150.00
041126-G	GIRLS GOLF		04/11/2026	150.00		
			ENTRY FEES/STDT TRVL-GIRLS ATHL-GOLF-		01 E 310 296 114 000 369	150.00
05/05/2026	60711	Check	HOBART SERVICE	1,224.14		
<b>Invoice Number</b>	<b>Description</b>		<b>Invoice Date</b>	<b>Invoice Amount</b>	<b>Account</b>	<b>Amount</b>
36990614	ELLIS - DISHWASHER REPAIR		10/24/2025	1,224.14		
			REPAIR & MAINT SVCS-FOOD SVC--NSLP		02 E 005 770 000 701 350	1,224.14

## Board Packet

AP Run: T261101 — Post Date: 2026-05-05 — AP Run Type: R

Austin Public Schools ISD 492

Check Date	Check Number	Payment Type	Name	Check Amount	
05/05/2026	60712	Check	HUNTLEY, MELINDA S	22.84	
<b>Invoice Number</b>	<b>Description</b>	<b>Invoice Date</b>	<b>Invoice Amount</b>	<b>Account</b>	<b>Amount</b>
042226	INDISTRICT MILEAGE REIM - APR 26	04/22/2026	22.84		
	IN-DISTRICT TRAVEL-SEC-HOMEBOUND-			01 E 005 211 432 000 367	22.84
05/05/2026	60713	Check	IMPERIAL DADE	2,536.75	
<b>Invoice Number</b>	<b>Description</b>	<b>Invoice Date</b>	<b>Invoice Amount</b>	<b>Account</b>	<b>Amount</b>
41434205	BLANKET PO FOR FISCALL YEAR 2025-2026	04/22/2026	2,536.75		
	CUSTODIAL SUPPLIES-OPERATIONS--			01 E 005 810 000 000 410	2,536.75
05/05/2026	60714	Check	KEMPS	19,863.65	
<b>Invoice Number</b>	<b>Description</b>	<b>Invoice Date</b>	<b>Invoice Amount</b>	<b>Account</b>	<b>Amount</b>
20016103663	MILK	04/09/2026	580.51		
				MILK-FOOD SVC--BREAKFAST 02 E 005 770 000 705 495	580.51
6260059	MILK	04/02/2026	156.95		
				MILK-FOOD SVC--BREAKFAST 02 E 005 770 000 705 495	156.95
6260100	MILK	04/02/2026	135.29		
				MILK-FOOD SVC--BREAKFAST 02 E 005 770 000 705 495	135.29
6263232	MILK	04/06/2026	706.20		
				MILK-FOOD SVC--BREAKFAST 02 E 005 770 000 705 495	706.20
6263236	MILK	04/06/2026	490.40		
				MILK-FOOD SVC--BREAKFAST 02 E 005 770 000 705 495	490.40
6263243	MILK	04/06/2026	607.85		
				MILK-FOOD SVC--BREAKFAST 02 E 005 770 000 705 495	607.85
6263245	MILK	04/07/2026	608.00		
				MILK-FOOD SVC--BREAKFAST 02 E 005 770 000 705 495	608.00
6263249	MILK	04/07/2026	563.74		
				MILK-FOOD SVC--BREAKFAST 02 E 005 770 000 705 495	563.74
6263255	MILK	04/07/2026	431.55		
				MILK-FOOD SVC--BREAKFAST 02 E 005 770 000 705 495	431.55
6263260	MILK	04/07/2026	372.60		
				MILK-FOOD SVC--BREAKFAST 02 E 005 770 000 705 495	372.60

## Board Packet

AP Run: T261101 — Post Date: 2026-05-05 — AP Run Type: R

Austin Public Schools ISD 492

Check Date	Check Number	Payment Type	Name	Check Amount	
05/05/2026	60714	Check	KEMPS	19,863.65	
Invoice Number	Description	Invoice Date	Invoice Amount	Account	Amount
6263265	MILK	04/07/2026	176.60		
		MILK-FOOD SVC--BREAKFAST		02 E 005 770 000 705 495	176.60
6269170	MILK	04/09/2026	387.10		
		MILK-FOOD SVC--BREAKFAST		02 E 005 770 000 705 495	387.10
6269178	MILK	04/09/2026	137.30		
		MILK-FOOD SVC--BREAKFAST		02 E 005 770 000 705 495	137.30
6271047	MILK	04/10/2026	442.22		
		MILK-FOOD SVC--BREAKFAST		02 E 005 770 000 705 495	442.22
6271053	MILK	04/10/2026	78.50		
		MILK-FOOD SVC--BREAKFAST		02 E 005 770 000 705 495	78.50
6271294	MILK	04/10/2026	566.30		
		MILK-FOOD SVC--BREAKFAST		02 E 005 770 000 705 495	566.30
6271302	MILK	04/10/2026	252.45		
		MILK-FOOD SVC--BREAKFAST		02 E 005 770 000 705 495	252.45
6271472	MILK	04/10/2026	507.15		
		MILK-FOOD SVC--BREAKFAST		02 E 005 770 000 705 495	507.15
6274764	MILK	04/14/2026	600.05		
		MILK-FOOD SVC--BREAKFAST		02 E 005 770 000 705 495	600.05
6274780	MILK	04/13/2026	799.74		
		MILK-FOOD SVC--BREAKFAST		02 E 005 770 000 705 495	799.74
6275582	MILK	04/13/2026	1,137.75		
		MILK-FOOD SVC--BREAKFAST		02 E 005 770 000 705 495	1,137.75
6275586	MILK	04/14/2026	666.90		
		MILK-FOOD SVC--BREAKFAST		02 E 005 770 000 705 495	666.90
6275748	MILK	04/14/2026	448.55		
		MILK-FOOD SVC--BREAKFAST		02 E 005 770 000 705 495	448.55
6275808	MILK	04/13/2026	661.50		
		MILK-FOOD SVC--BREAKFAST		02 E 005 770 000 705 495	661.50

## Board Packet

AP Run: T261101 — Post Date: 2026-05-05 — AP Run Type: R

Austin Public Schools ISD 492

Check Date	Check Number	Payment Type	Name	Check Amount	
05/05/2026	60714	Check	KEMPS	19,863.65	
Invoice Number	Description	Invoice Date	Invoice Amount	Account	Amount
6275867	MILK	04/14/2026	664.30		
		MILK-FOOD SVC--BREAKFAST		02 E 005 770 000 705 495	664.30
6279822	MILK	04/16/2026	664.25		
		MILK-FOOD SVC--BREAKFAST		02 E 005 770 000 705 495	664.25
6280275	MILK	04/16/2026	392.50		
		MILK-FOOD SVC--BREAKFAST		02 E 005 770 000 705 495	392.50
6280384	MILK	04/16/2026	215.75		
		MILK-FOOD SVC--BREAKFAST		02 E 005 770 000 705 495	215.75
6282507	MILK	04/17/2026	429.00		
		MILK-FOOD SVC--BREAKFAST		02 E 005 770 000 705 495	429.00
6282529	MILK	04/17/2026	294.25		
		MILK-FOOD SVC--BREAKFAST		02 E 005 770 000 705 495	294.25
6282579	MILK	04/17/2026	176.60		
		MILK-FOOD SVC--BREAKFAST		02 E 005 770 000 705 495	176.60
6282620	MILK	04/17/2026	411.90		
		MILK-FOOD SVC--BREAKFAST		02 E 005 770 000 705 495	411.90
6286766	MILK	04/20/2026	686.65		
		MILK-FOOD SVC--BREAKFAST		02 E 005 770 000 705 495	686.65
6286779	MILK	04/21/2026	667.00		
		MILK-FOOD SVC--BREAKFAST		02 E 005 770 000 705 495	667.00
6286784	MILK	04/21/2026	745.45		
		MILK-FOOD SVC--BREAKFAST		02 E 005 770 000 705 495	745.45
6286788	MILK	04/20/2026	392.40		
		MILK-FOOD SVC--BREAKFAST		02 E 005 770 000 705 495	392.40
6287191	MILK	04/21/2026	451.20		
		MILK-FOOD SVC--BREAKFAST		02 E 005 770 000 705 495	451.20
6287193	MILK	04/20/2026	470.65		
		MILK-FOOD SVC--BREAKFAST		02 E 005 770 000 705 495	470.65

## Board Packet

AP Run: T261101 — Post Date: 2026-05-05 — AP Run Type: R

Austin Public Schools ISD 492

Check Date	Check Number	Payment Type	Name	Check Amount	
05/05/2026	60714	Check	KEMPS	19,863.65	
Invoice Number	Description	Invoice Date	Invoice Amount	Account	Amount
6287200	MILK	04/21/2026	549.15		
		MILK-FOOD SVC--BREAKFAST		02 E 005 770 000 705 495	549.15
6291476	MILK	04/23/2026	549.25		
		MILK-FOOD SVC--BREAKFAST		02 E 005 770 000 705 495	549.25
6291567	MILK	04/23/2026	372.55		
		MILK-FOOD SVC--BREAKFAST		02 E 005 770 000 705 495	372.55
6291571	MILK	04/23/2026	215.60		
		MILK-FOOD SVC--BREAKFAST		02 E 005 770 000 705 495	215.60
05/05/2026	60715	Check	LAKEVILLE NORTH PUBLIC SCHOOLS	225.00	
Invoice Number	Description	Invoice Date	Invoice Amount	Account	Amount
042726	BOYS GOLF	04/27/2026	225.00		
		ENTRY FEES/STDT TRVL-BOYS ATHL-GOLF-		01 E 310 294 114 000 369	225.00
05/05/2026	60716	Check	M J O'CONNOR INC	2,841.80	
Invoice Number	Description	Invoice Date	Invoice Amount	Account	Amount
50324	ELLIS - SCIENCE LAB PIT - MODIFY 4" DRAIN	04/23/2026	1,053.90		
		REPAIR/MAINTENANCE-LTFM--PLUMBING		05 E 005 865 000 381 350	1,053.90
50513	ELLIS - WATER LEAK BY DOOR 12	04/23/2026	1,787.90		
		REPAIR/MAINTENANCE-LTFM--PLUMBING		05 E 005 865 000 381 350	1,787.90
05/05/2026	60717	Check	MARREEL, DANIEL P	567.00	
Invoice Number	Description	Invoice Date	Invoice Amount	Account	Amount
050426	STATE ADAPTED BOWLING FOOD 5/8/26	05/04/2026	567.00		
		ENTRY FEE/STDT TRVL-BOY/GIRL ATHL-ADAPTIVE BOWLING		01 E 310 292 120 000 369	567.00
05/05/2026	60718	Check	MARREEL, LAURA A	833.04	
Invoice Number	Description	Invoice Date	Invoice Amount	Account	Amount
15416688	UPRINTING REIM	04/16/2026	833.04		
		GEN SUPPLIES-TITLE I-PR YR PARENTAL INVOLV-TITLE I		01 E 155 216 631 401 401	833.04

## Board Packet

AP Run: T261101 — Post Date: 2026-05-05 — AP Run Type: R

Austin Public Schools ISD 492

Check Date	Check Number	Payment Type	Name	Check Amount	
05/05/2026	60719	Check	MARTIN BROS DISTRIBUTING CO	105,717.10	
Invoice Number	Description	Invoice Date	Invoice Amount	Account	Amount
2572767	FOOD & SUPPLIES (NSLP SUPPLIES)	04/02/2026	230.68		
				GEN SUPPLIES-FOOD SVC--NSLP 02 E 005 770 000 701 401	230.68
2572768	FOOD & SUPPLIES (NSLP SUPPLIES)	04/02/2026	4,799.10		
				FOOD-FOOD SVC--NSLP 02 E 005 770 000 701 490	4,799.10
2572769	FOOD & SUPPLIES (NSLP SUPPLIES)	04/02/2026	805.45		
				FOOD-FOOD SVC--BREAKFAST 02 E 005 770 000 705 490	805.45
2572770	FOOD & SUPPLIES (NSLP SUPPLIES)	04/02/2026	25.90		
				FOOD-FOOD SVC--NSLP 02 E 005 770 000 701 490	25.90
2580026	FOOD & SUPPLIES (NSLP SUPPLIES)	04/07/2026	8,248.36		
				FOOD-FOOD SVC--NSLP 02 E 005 770 000 701 490	8,248.36
2580027	FOOD & SUPPLIES (NSLP SUPPLIES)	04/07/2026	2,250.91		
				FOOD-FOOD SVC--BREAKFAST 02 E 005 770 000 705 490	2,250.91
2580028	FOOD & SUPPLIES (NSLP SUPPLIES)	04/07/2026	334.17		
				GEN SUPPLIES-FOOD SVC--NSLP 02 E 005 770 000 701 401	334.17
2580029	FOOD & SUPPLIES (NSLP SUPPLIES)	04/07/2026	349.26		
				FOOD-FOOD SVC--BREAKFAST 02 E 005 770 000 705 490	349.26
2582761	FOOD & SUPPLIES (NSLP SUPPLIES)	04/09/2026	159.74		
				FOOD-FOOD SVC--AFTER SCH SNACK 02 E 005 770 000 702 490	159.74
2582762	FOOD & SUPPLIES (NSLP SUPPLIES)	04/09/2026	4,875.19		
				GEN SUPPLIES-FOOD SVC--NSLP 02 E 005 770 000 701 401	4,875.19
2582763	FOOD & SUPPLIES (NSLP SUPPLIES)	04/09/2026	2,194.30		
				FOOD-FOOD SVC--BREAKFAST 02 E 005 770 000 705 490	2,194.30
2582764	FOOD & SUPPLIES (NSLP SUPPLIES)	04/09/2026	125.38		
				FOOD-FOOD SVC--NSLP 02 E 005 770 000 701 490	125.38
2582765	FOOD & SUPPLIES (NSLP SUPPLIES)	04/09/2026	214.00		
				FOOD-FOOD SVC--AFTER SCH SNACK 02 E 005 770 000 702 490	214.00
2582766	FOOD & SUPPLIES (NSLP SUPPLIES)	04/09/2026	788.50		
				GEN SUPPLIES-FOOD SVC--NSLP 02 E 005 770 000 701 401	788.50

## Board Packet

AP Run: T261101 — Post Date: 2026-05-05 — AP Run Type: R

Austin Public Schools ISD 492

Check Date	Check Number	Payment Type	Name	Check Amount	
05/05/2026	60719	Check	MARTIN BROS DISTRIBUTING CO	105,717.10	
Invoice Number	Description	Invoice Date	Invoice Amount	Account	Amount
2582767	FOOD & SUPPLIES (NSLP SUPPLIES)	04/09/2026	485.28		
				FOOD-FOOD SVC--NSLP 02 E 005 770 000 701 490	485.28
2582768	FOOD & SUPPLIES (NSLP SUPPLIES)	04/09/2026	44.91		
				FOOD-FOOD SVC--AFTER SCH SNACK 02 E 005 770 000 702 490	44.91
2582773	FOOD & SUPPLIES (NSLP SUPPLIES)	04/09/2026	945.22		
				FOOD-FOOD SVC--BREAKFAST 02 E 005 770 000 705 490	945.22
2582774	FOOD & SUPPLIES (NSLP SUPPLIES)	04/09/2026	3,089.51		
				FOOD-FOOD SVC--NSLP 02 E 005 770 000 701 490	3,089.51
2582775	FOOD & SUPPLIES (NSLP SUPPLIES)	04/09/2026	62.69		
				FOOD-FOOD SVC--NSLP 02 E 005 770 000 701 490	62.69
2582776	FOOD & SUPPLIES (NSLP SUPPLIES)	04/09/2026	11.12		
				FOOD-FOOD SVC--ALA-CARTE 02 E 005 770 000 707 490	11.12
2582777	FOOD & SUPPLIES (NSLP SUPPLIES)	04/09/2026	341.48		
				GEN SUPPLIES-FOOD SVC--NSLP 02 E 005 770 000 701 401	341.48
2582778	FOOD & SUPPLIES (NSLP SUPPLIES)	04/09/2026	225.66		
				FOOD-FOOD SVC--NSLP 02 E 005 770 000 701 490	225.66
2590901	FOOD & SUPPLIES (NSLP SUPPLIES)	04/14/2026	382.89		
				FOOD-FOOD SVC--BREAKFAST 02 E 005 770 000 705 490	382.89
2590902	FOOD & SUPPLIES (NSLP SUPPLIES)	04/14/2026	42.21		
				FOOD-FOOD SVC--ALA-CARTE 02 E 005 770 000 707 490	42.21
2590903	FOOD & SUPPLIES (NSLP SUPPLIES)	04/14/2026	6,183.74		
				FOOD-FOOD SVC--NSLP 02 E 005 770 000 701 490	6,183.74
2590904	FOOD & SUPPLIES (NSLP SUPPLIES)	04/14/2026	1,209.43		
				FOOD-FOOD SVC--NSLP 02 E 005 770 000 701 490	1,209.43
2590905	FOOD & SUPPLIES (NSLP SUPPLIES)	04/14/2026	4,091.24		
				FOOD-FOOD SVC--BREAKFAST 02 E 005 770 000 705 490	4,091.24
2590906	FOOD & SUPPLIES (NSLP SUPPLIES)	04/14/2026	162.84		
				FOOD-FOOD SVC--NSLP 02 E 005 770 000 701 490	162.84

## Board Packet

AP Run: T261101 — Post Date: 2026-05-05 — AP Run Type: R

Austin Public Schools ISD 492

Check Date	Check Number	Payment Type	Name	Check Amount	
05/05/2026	60719	Check	MARTIN BROS DISTRIBUTING CO	105,717.10	
Invoice Number	Description	Invoice Date	Invoice Amount	Account	Amount
2590907	FOOD & SUPPLIES (NSLP SUPPLIES)	04/14/2026	227.64		
		GEN SUPPLIES-FOOD SVC--NSLP		02 E 005 770 000 701 401	227.64
2590908	FOOD & SUPPLIES (NSLP SUPPLIES)	04/14/2026	278.00		
		FOOD-FOOD SVC--ALA-CARTE		02 E 005 770 000 707 490	278.00
2590909	FOOD & SUPPLIES (NSLP SUPPLIES)	04/14/2026	443.90		
		FOOD-FOOD SVC--NSLP		02 E 005 770 000 701 490	443.90
2590910	FOOD & SUPPLIES (NSLP SUPPLIES)	04/14/2026	138.18		
		FOOD-FOOD SVC--BREAKFAST		02 E 005 770 000 705 490	138.18
2590913	FOOD & SUPPLIES (NSLP SUPPLIES)	04/14/2026	63.36		
		FOOD-FOOD SVC--BREAKFAST		02 E 005 770 000 705 490	63.36
2590914	FOOD & SUPPLIES (NSLP SUPPLIES)	04/14/2026	2,731.93		
		FOOD-FOOD SVC--NSLP		02 E 005 770 000 701 490	2,731.93
2590915	FOOD & SUPPLIES (NSLP SUPPLIES)	04/14/2026	367.23		
		GEN SUPPLIES-FOOD SVC--NSLP		02 E 005 770 000 701 401	367.23
2590916	FOOD & SUPPLIES (NSLP SUPPLIES)	04/14/2026	121.32		
		FOOD-FOOD SVC--NSLP		02 E 005 770 000 701 490	121.32
2594807	FOOD & SUPPLIES (NSLP SUPPLIES)	04/16/2026	205.75		
		FOOD-FOOD SVC--AFTER SCH SNACK		02 E 005 770 000 702 490	205.75
2594808	FOOD & SUPPLIES (NSLP SUPPLIES)	04/16/2026	92.39		
		FOOD-FOOD SVC--ALA-CARTE		02 E 005 770 000 707 490	92.39
2594809	FOOD & SUPPLIES (NSLP SUPPLIES)	04/16/2026	3,137.95		
		FOOD-FOOD SVC--NSLP		02 E 005 770 000 701 490	3,137.95
2594810	FOOD & SUPPLIES (NSLP SUPPLIES)	04/16/2026	501.52		
		FOOD-FOOD SVC--NSLP		02 E 005 770 000 701 490	501.52
2594811	FOOD & SUPPLIES (NSLP SUPPLIES)	04/16/2026	3,922.63		
		FOOD-FOOD SVC--BREAKFAST		02 E 005 770 000 705 490	3,922.63
2594812	FOOD & SUPPLIES (NSLP SUPPLIES)	04/16/2026	23.34		
		FOOD-FOOD SVC--ALA-CARTE		02 E 005 770 000 707 490	23.34

## Board Packet

AP Run: T261101 — Post Date: 2026-05-05 — AP Run Type: R

Austin Public Schools ISD 492

Check Date	Check Number	Payment Type	Name	Check Amount	
05/05/2026	60719	Check	MARTIN BROS DISTRIBUTING CO	105,717.10	
Invoice Number	Description	Invoice Date	Invoice Amount	Account	Amount
2594813	FOOD & SUPPLIES (NSLP SUPPLIES)	04/16/2026	311.75		
		FOOD-FOOD SVC--NSLP		02 E 005 770 000 701 490	311.75
2594818	FOOD & SUPPLIES (NSLP SUPPLIES)	04/16/2026	269.56		
		FOOD-FOOD SVC--BREAKFAST		02 E 005 770 000 705 490	269.56
2594819	FOOD & SUPPLIES (NSLP SUPPLIES)	04/16/2026	3,353.77		
		FOOD-FOOD SVC--NSLP		02 E 005 770 000 701 490	3,353.77
2594820	FOOD & SUPPLIES (NSLP SUPPLIES)	04/16/2026	62.69		
		FOOD-FOOD SVC--NSLP		02 E 005 770 000 701 490	62.69
2594821	FOOD & SUPPLIES (NSLP SUPPLIES)	04/16/2026	5.56		
		FOOD-FOOD SVC--ALA-CARTE		02 E 005 770 000 707 490	5.56
2594822	FOOD & SUPPLIES (NSLP SUPPLIES)	04/16/2026	222.60		
		GEN SUPPLIES-FOOD SVC--NSLP		02 E 005 770 000 701 401	222.60
2594823	FOOD & SUPPLIES (NSLP SUPPLIES)	04/16/2026	44.51		
		FOOD-FOOD SVC--NSLP		02 E 005 770 000 701 490	44.51
2602986	FOOD & SUPPLIES (NSLP SUPPLIES)	04/21/2026	14,888.19		
		FOOD-FOOD SVC--NSLP		02 E 005 770 000 701 490	14,888.19
2602987	FOOD & SUPPLIES (NSLP SUPPLIES)	04/21/2026	2,777.52		
		FOOD-FOOD SVC--BREAKFAST		02 E 005 770 000 705 490	2,777.52
2602988	FOOD & SUPPLIES (NSLP SUPPLIES)	04/21/2026	449.45		
		FOOD-FOOD SVC--NSLP		02 E 005 770 000 701 490	449.45
2605796	FOOD & SUPPLIES (NSLP SUPPLIES)	04/23/2026	317.25		
		FOOD-FOOD SVC--NSLP		02 E 005 770 000 701 490	317.25
2605797	FOOD & SUPPLIES (NSLP SUPPLIES)	04/23/2026	4,519.69		
		FOOD-FOOD SVC--NSLP		02 E 005 770 000 701 490	4,519.69
2605798	FOOD & SUPPLIES (NSLP SUPPLIES)	04/23/2026	5,493.17		
		FOOD-FOOD SVC--BREAKFAST		02 E 005 770 000 705 490	5,493.17
2605799	FOOD & SUPPLIES (NSLP SUPPLIES)	04/23/2026	1,040.40		
		GEN SUPPLIES-FOOD SVC--NSLP		02 E 005 770 000 701 401	1,040.40

## Board Packet

AP Run: T261101 — Post Date: 2026-05-05 — AP Run Type: R

Austin Public Schools ISD 492

Check Date	Check Number	Payment Type	Name	Check Amount
05/05/2026	60719	Check	MARTIN BROS DISTRIBUTING CO	105,717.10

Invoice Number	Description	Invoice Date	Invoice Amount	Account	Amount
2605800	FOOD & SUPPLIES (NSLP SUPPLIES)	04/23/2026	97.17		
				FOOD-FOOD SVC--NSLP 02 E 005 770 000 701 490	97.17
2605801	FOOD & SUPPLIES (NSLP SUPPLIES)	04/23/2026	431.24		
				FOOD-FOOD SVC--NSLP 02 E 005 770 000 701 490	431.24
2614045	FOOD & SUPPLIES (NSLP SUPPLIES)	04/28/2026	110.67		
				FOOD-FOOD SVC--ALA-CARTE 02 E 005 770 000 707 490	110.67
2614046	FOOD & SUPPLIES (NSLP SUPPLIES)	04/28/2026	22.15		
				FOOD-FOOD SVC--ALA-CARTE 02 E 005 770 000 707 490	22.15
2614047	FOOD & SUPPLIES (NSLP SUPPLIES)	04/28/2026	10,316.13		
				FOOD-FOOD SVC--NSLP 02 E 005 770 000 701 490	10,316.13
2614048	FOOD & SUPPLIES (NSLP SUPPLIES)	04/28/2026	1,988.27		
				FOOD-FOOD SVC--BREAKFAST 02 E 005 770 000 705 490	1,988.27
2614049	FOOD & SUPPLIES (NSLP SUPPLIES)	04/28/2026	49.51		
				FOOD-FOOD SVC--ALA-CARTE 02 E 005 770 000 707 490	49.51
2614050	FOOD & SUPPLIES (NSLP SUPPLIES)	04/28/2026	167.60		
				FOOD-FOOD SVC--NSLP 02 E 005 770 000 701 490	167.60
2614051	FOOD & SUPPLIES (NSLP SUPPLIES)	04/28/2026	457.95		
				FOOD-FOOD SVC--NSLP 02 E 005 770 000 701 490	457.95
2614052	FOOD & SUPPLIES (NSLP SUPPLIES)	04/28/2026	3,386.00		
				FOOD-FOOD SVC--NSLP 02 E 005 770 000 701 490	3,386.00

05/05/2026	60720	Check	MCKICHAN, ANDREA J	75.45
------------	-------	-------	--------------------	-------

Invoice Number	Description	Invoice Date	Invoice Amount	Account	Amount
131746	LITTLE ANGIES DINNER REIM - MCTM CONF	04/24/2026	26.00		
				TRAVEL CONV & CONF-CURRICULUM--STAFF DEV 01 E 005 610 000 316 366	26.00
337219	GRANDMAS SALOON DINNER REIM - MCTM CONF	04/23/2026	23.45		
				TRAVEL CONV & CONF-CURRICULUM--STAFF DEV 01 E 005 610 000 316 366	23.45
682154	STARBUCKS BREAKFAST REIM - MCTM CONF	04/25/2026	13.00		
				TRAVEL CONV & CONF-CURRICULUM--STAFF DEV 01 E 005 610 000 316 366	13.00

## Board Packet

AP Run: T261101 — Post Date: 2026-05-05 — AP Run Type: R

Austin Public Schools ISD 492

Check Date	Check Number	Payment Type	Name	Check Amount	
05/05/2026	60720	Check	MCKICHAN, ANDREA J	75.45	
<b>Invoice Number</b>	<b>Description</b>	<b>Invoice Date</b>	<b>Invoice Amount</b>	<b>Account</b>	<b>Amount</b>
683897	STARBUCKS BREAKFAST REIM - MCTM CONF	04/24/2026	13.00		
	TRAVEL CONV & CONF-CURRICULUM--STAFF DEV			01 E 005 610 000 316 366	13.00
05/05/2026	60721	Check	MCLAREN, ASHLEY M	66.64	
<b>Invoice Number</b>	<b>Description</b>	<b>Invoice Date</b>	<b>Invoice Amount</b>	<b>Account</b>	<b>Amount</b>
1077749	CHICK-FIL-A LUNCH REIM - MCTM CONF	04/25/2026	9.75		
	TRAVEL CONV & CONF-CURRICULUM--STAFF DEV			01 E 005 610 000 316 366	9.75
131746	LITTLE ANGIES DINNER REIM - MCTM CONF	04/24/2026	26.00		
	TRAVEL CONV & CONF-CURRICULUM--STAFF DEV			01 E 005 610 000 316 366	26.00
337219	GRANDMAS SALOON DINNER REIM - MCTM CONF	04/23/2026	20.11		
	TRAVEL CONV & CONF-CURRICULUM--STAFF DEV			01 E 005 610 000 316 366	20.11
682457	STARBUCKS BREAKFAST REIM - MCTM CONF	04/25/2026	10.78		
	TRAVEL CONV & CONF-CURRICULUM--STAFF DEV			01 E 005 610 000 316 366	10.78
05/05/2026	60722	Check	MCMANUS, CARIN	513.54	
<b>Invoice Number</b>	<b>Description</b>	<b>Invoice Date</b>	<b>Invoice Amount</b>	<b>Account</b>	<b>Amount</b>
111-6723095-9769818	CEO - AMAZON REIM	01/19/2026	101.55		
	GEN SUPPLIES-SEC-CEO PROGRAM-			01 E 310 211 206 000 401	101.55
113-0170505-3245012	CEO - AMAZON REIM	04/23/2026	22.21		
	GEN SUPPLIES-SEC-CEO PROGRAM-			01 E 310 211 206 000 401	22.21
113-3866092-6943434	CEO - AMAZON REIM	04/28/2026	128.63		
	GEN SUPPLIES-SEC-CEO PROGRAM-			01 E 310 211 206 000 401	128.63
113-7547556-7462632	CEO - AMAZON REIM	11/27/2025	261.15		
	GEN SUPPLIES-SEC-CEO PROGRAM-			01 E 310 211 206 000 401	261.15

## Board Packet

AP Run: T261101 — Post Date: 2026-05-05 — AP Run Type: R

Austin Public Schools ISD 492

Check Date	Check Number	Payment Type	Name	Check Amount	
05/05/2026	60723	Check	NORRIS, MARY B	23.93	
<b>Invoice Number</b>	<b>Description</b>	<b>Invoice Date</b>	<b>Invoice Amount</b>	<b>Account</b>	<b>Amount</b>
043026	INDISTRICT MILEAGE REIM APR 26	04/30/2026	23.93		
			IN-DISTRICT TRAVEL-VIS IMPAIRED--IDEA-611	01 E 005 406 000 419 367	23.93
05/05/2026	60724	Check	OSGOOD, HEATHER M	495.69	
<b>Invoice Number</b>	<b>Description</b>	<b>Invoice Date</b>	<b>Invoice Amount</b>	<b>Account</b>	<b>Amount</b>
032526	INDISTRICT MILEAGE REIM - MAR 26	03/25/2026	287.25		
			TRAVEL CONV & CONF-DEAF-HA-SHARED COST-	01 E 005 405 700 000 366	287.25
033026	INDISTRICT MILEAGE REIM MAR 26	03/30/2026	125.86		
			TRAVEL CONV & CONF-DEAF-HA-SHARED COST-	01 E 005 405 700 000 366	125.86
033126	INDISTRICT MILEAGE REIM - MAR 26	03/31/2026	82.58		
			IN-DISTRICT TRAVEL-DEAF-HA--IDEA-611	01 E 005 405 000 419 367	15.88
			TRAVEL CONV & CONF-DEAF-HA-PRO DEV-IDEA-611	01 E 005 405 640 419 366	66.70
05/05/2026	60725	Check	OWATONNA PUBLIC SCHOOLS	849.00	
<b>Invoice Number</b>	<b>Description</b>	<b>Invoice Date</b>	<b>Invoice Amount</b>	<b>Account</b>	<b>Amount</b>
22935	PERKINS: FACS TO THE MAX REGISTRATION, QUIZIZZ SOFTWARE, SERV SAFE FOOD HANDLER COURSE	04/24/2026	849.00		
			FED CNTRCT < \$25K-CTE-GENERAL--CARL PERKINS	12 E 300 399 000 428 303	849.00
05/05/2026	60726	Check	OXBOW PARK	150.00	
<b>Invoice Number</b>	<b>Description</b>	<b>Invoice Date</b>	<b>Invoice Amount</b>	<b>Account</b>	<b>Amount</b>
041426	AHS WILDLIFE CLASS FIELD TRIP	04/14/2026	150.00		
			PMT FOR ED PURP-AGRI-FARM OPER-CTE	01 E 310 301 501 801 394	150.00
05/05/2026	60727	Check	PERFORMANCE OFFICE PAPERS, INC	12,160.00	
<b>Invoice Number</b>	<b>Description</b>	<b>Invoice Date</b>	<b>Invoice Amount</b>	<b>Account</b>	<b>Amount</b>
453376-00	2026 COPY PAPER ORDER	04/16/2026	12,160.00		
			WAREHOUSE	-BUSINESS OFFICE-- 01 E 005 110 000 000 499	12,160.00

## Board Packet

AP Run: T261101 — Post Date: 2026-05-05 — AP Run Type: R

Austin Public Schools ISD 492

Check Date	Check Number	Payment Type	Name	Check Amount		
05/05/2026	60728	Check	PRIOR LAKE HIGH SCHOOL	300.00		
<b>Invoice Number</b>	<b>Description</b>		<b>Invoice Date</b>	<b>Invoice Amount</b>	<b>Account</b>	<b>Amount</b>
041126	BOYS VOLLEYBALL		04/11/2026	300.00		
	ENTRY FEES/STUDENT TRVL-BOYS ATHL-VOLLEYBALL				01 E 310 294 116 000 369	300.00
05/05/2026	60729	Check	RADNIECKI, JESSICA	64.10		
<b>Invoice Number</b>	<b>Description</b>		<b>Invoice Date</b>	<b>Invoice Amount</b>	<b>Account</b>	<b>Amount</b>
031926	INDISTRICT MILEAGE REIM MAR 26		03/19/2026	9.43		
	TRAVEL-VISUALLY IMPAIRED-SHARED COSTS W/DISTRICTS-				01 E 005 406 700 000 366	9.43
033126	INDISTRICT MILEAGE REIM MAR 26		03/31/2026	21.97		
	IN-DISTRICT TRAVEL-VIS IMPAIRED--IDEA-611				01 E 005 406 000 419 367	21.97
042226	INDISTRICT MILEAGE REIM APR 26		04/22/2026	22.77		
	IN-DISTRICT TRAVEL-VIS IMPAIRED--IDEA-611				01 E 005 406 000 419 367	22.77
043026	INDISTRICT MILEAGE REIM APR 26		04/30/2026	9.93		
	TRAVEL-VISUALLY IMPAIRED-SHARED COSTS W/DISTRICTS-				01 E 005 406 700 000 366	9.93
05/05/2026	60730	Check	RATWIK ROSZAK & MALONEY PA	3,988.50		
<b>Invoice Number</b>	<b>Description</b>		<b>Invoice Date</b>	<b>Invoice Amount</b>	<b>Account</b>	<b>Amount</b>
1837	0492-0155 BUILDING LEASE ISSUES MEETING		04/01/2026	427.50		
					LEGAL SERVICES-PERSONNEL-- 01 E 005 160 000 000 313	427.50
1838	LEGAL SERVICES - MARCH 2026		04/01/2026	3,561.00		
					LEGAL SERVICES-PERSONNEL-- 01 E 005 160 000 000 313	3,561.00
05/05/2026	60731	Check	RIVERLAND COMMUNITY COLLEGE	27,565.47		
<b>Invoice Number</b>	<b>Description</b>		<b>Invoice Date</b>	<b>Invoice Amount</b>	<b>Account</b>	<b>Amount</b>
C10000016279	CONCURRENT ENROLLMENT FALL 2025 TERM & STUDENT ASSOCIATION FEES		12/17/2025	27,565.47		
					PMT FOR ED PURP-SEC--PSEO CONTRACT 01 E 310 211 000 090 394	27,565.47
05/05/2026	60732	Check	ROCHESTER AREA OFFICIALS ASSOCIATION	125.00		
<b>Invoice Number</b>	<b>Description</b>		<b>Invoice Date</b>	<b>Invoice Amount</b>	<b>Account</b>	<b>Amount</b>
0023	RAOA ASSIGNING FEE 2025-2026		04/28/2026	125.00		
					DUES & MEMBERSHIPS-BOY/GIRL-ATHLETICS- 01 E 310 292 100 000 820	125.00

## Board Packet

AP Run: T261101 — Post Date: 2026-05-05 — AP Run Type: R

Austin Public Schools ISD 492

Check Date	Check Number	Payment Type	Name	Check Amount	
05/05/2026	60733	Check	ROCHESTER PUBLIC SCHOOLS #535	1,977.50	
<b>Invoice Number</b>	<b>Description</b>	<b>Invoice Date</b>	<b>Invoice Amount</b>	<b>Account</b>	<b>Amount</b>
1002500553	5 STAR QUILTS & POWWOW CONTRIBUTION (FOOD)	04/21/2026	1,977.50		
	GEN SUPPLIES-OTH PUP SUP--AM INDIAN ED AID			01 E 005 790 000 320 401	1,477.50
	FOOD-OTH PUP SUP--AM INDIAN ED AID			01 E 005 790 000 320 490	500.00
05/05/2026	60734	Check	SMILEY, KENECIA	66.00	
<b>Invoice Number</b>	<b>Description</b>	<b>Invoice Date</b>	<b>Invoice Amount</b>	<b>Account</b>	<b>Amount</b>
23459342	CEO - BRAMBLE BERRY REIM	04/08/2026	29.11		
	GEN SUPPLIES-SEC-CEO PROGRAM-			01 E 310 211 206 000 401	29.11
FRUS2025-33705	CEO - BIZAY REIM	03/04/2026	36.89		
	GEN SUPPLIES-SEC-CEO PROGRAM-			01 E 310 211 206 000 401	36.89
05/05/2026	60735	Check	SOLIANT HEALTH LLC	3,260.53	
<b>Invoice Number</b>	<b>Description</b>	<b>Invoice Date</b>	<b>Invoice Amount</b>	<b>Account</b>	<b>Amount</b>
21435274	CONTRACTED SLP	04/19/2026	3,260.53		
	PMT FOR ED PURP-SPEECH--STATE SPED			01 E 005 401 000 740 394	3,260.53
05/05/2026	60736	Check	SOLUTION TREE INC	1,598.00	
<b>Invoice Number</b>	<b>Description</b>	<b>Invoice Date</b>	<b>Invoice Amount</b>	<b>Account</b>	<b>Amount</b>
S340749	PROFESSIONAL LEARNING COMMUNITIES AT WORK INSTITUTE JUNE 9-11TH, 2026	04/15/2026	1,598.00		
	TRAVEL CONV & CONF-STAFF DEV--STAFF DEV			01 E 105 640 000 316 366	1,598.00
05/05/2026	60737	Check	SOUTHERN MN INSPECTIONS CO	3,132.14	
<b>Invoice Number</b>	<b>Description</b>	<b>Invoice Date</b>	<b>Invoice Amount</b>	<b>Account</b>	<b>Amount</b>
26511	BANFIELD REPAIRS FROM 2025 INSPECTIONS	01/09/2026	2,578.44		
	REPAIR/MAINTENANCE-LTFM--PHYSICAL HAZARDS			05 E 005 865 000 347 350	2,578.44
26780	AUTO LIFT INSPECTIONS	02/25/2026	553.70		
	REPAIR/MAINTENANCE-LTFM--PHYSICAL HAZARDS			05 E 005 865 000 347 350	553.70

## Board Packet

AP Run: T261101 — Post Date: 2026-05-05 — AP Run Type: R

Austin Public Schools ISD 492

Check Date	Check Number	Payment Type	Name	Check Amount	
05/05/2026	60738	Check	STANGE, RACHEL R	789.72	
<b>Invoice Number</b>	<b>Description</b>	<b>Invoice Date</b>	<b>Invoice Amount</b>	<b>Account</b>	<b>Amount</b>
042926-AE	TEXTBOOK REIM - ACADEMIC EXCELLENCE	04/29/2026	150.00		
	TEXTBOOK/WORKBOOK-OTH COM PRG--NON PUB TEXT			04 E 799 590 000 351 460	150.00
7318160-1-1	TEXTBOOK REIM - IXL LEARNING	09/15/2025	129.00		
	TEXTBOOK/WORKBOOK-OTH COM PRG--NON PUB TEXT			04 E 799 590 000 351 460	129.00
7318160-1-2	TEXTBOOK REIM - IXL LEARNING	10/06/2025	150.79		
	TEXTBOOK/WORKBOOK-OTH COM PRG--NON PUB TEXT			04 E 799 590 000 351 460	150.79
7318160-1-3	TEXTBOOK REIM - IXL LEARNING	10/06/2025	37.70		
	TEXTBOOK/WORKBOOK-OTH COM PRG--NON PUB TEXT			04 E 799 590 000 351 460	37.70
AMAZON	TEXTBOOK REIM - AMAZON	07/30/2025	90.89		
	TEXTBOOK/WORKBOOK-OTH COM PRG--NON PUB TEXT			04 E 799 590 000 351 460	90.89
CB20253158274	TEXTBOOK REIM - READING EGGS	08/20/2025	69.99		
	TEXTBOOK/WORKBOOK-OTH COM PRG--NON PUB TEXT			04 E 799 590 000 351 460	69.99
CB20253159039	TEXTBOOK REIM - READING EGGS	08/20/2025	69.99		
	TEXTBOOK/WORKBOOK-OTH COM PRG--NON PUB TEXT			04 E 799 590 000 351 460	69.99
TPT	TEXTBOOK REIM - TPT	08/28/2025	91.36		
	TEXTBOOK/WORKBOOK-OTH COM PRG--NON PUB TEXT			04 E 799 590 000 351 460	91.36
05/05/2026	60739	Check	SUNBELT STAFFING	4,003.13	
<b>Invoice Number</b>	<b>Description</b>	<b>Invoice Date</b>	<b>Invoice Amount</b>	<b>Account</b>	<b>Amount</b>
21436999	CONTRACTED SCHOOL PSYCH	04/19/2026	4,003.13		
	PMT FOR ED PURP-SPED AGG--STATE SPED			01 E 005 420 000 740 394	4,003.13
05/05/2026	60740	Check	SUPER DUPER PUBLICATIONS	312.95	
<b>Invoice Number</b>	<b>Description</b>	<b>Invoice Date</b>	<b>Invoice Amount</b>	<b>Account</b>	<b>Amount</b>
3057168A	SPEECH MATERIALS	04/21/2026	312.95		
	INDIV INST SUPPLIES-SPEECH--STATE SPED			01 E 005 401 000 740 433	312.95
05/05/2026	60741	Check	SUPER FRESH PRODUCE & BAKERY	2,491.33	
<b>Invoice Number</b>	<b>Description</b>	<b>Invoice Date</b>	<b>Invoice Amount</b>	<b>Account</b>	<b>Amount</b>
2076	PROM FOOD	04/27/2026	2,491.33		
	FOOD-EXT CUR-PROM-SA			88 E 310 298 042 301 490	2,491.33

## Board Packet

AP Run: T261101 — Post Date: 2026-05-05 — AP Run Type: R

Austin Public Schools ISD 492

Check Date	Check Number	Payment Type	Name	Check Amount		
05/05/2026	60742	Check	THE BOELTER COMPANIES INC	29,142.31		
<u>Invoice Number</u>	<u>Description</u>		<u>Invoice Date</u>	<u>Invoice Amount</u>	<u>Account</u>	<u>Amount</u>
9100070002	DISHWASHER @ ELLIS MIDDLE SCHOOL		04/23/2026	29,142.31		
			EQUIPMENT-FOOD SVC--NSLP		02 E 005 770 000 701 530	29,142.31
05/05/2026	60743	Check	THE SIGN PRODUCERS INC	5,650.00		
<u>Invoice Number</u>	<u>Description</u>		<u>Invoice Date</u>	<u>Invoice Amount</u>	<u>Account</u>	<u>Amount</u>
20841	IJ HOLTON CAFETERIA SIGNAGE		04/28/2026	5,650.00		
			EQUIPMENT-FOOD SVC--NSLP		02 E 005 770 000 701 530	5,650.00
05/05/2026	60744	Check	THE TRANNY SHOP OF AUSTIN	2,840.07		
<u>Invoice Number</u>	<u>Description</u>		<u>Invoice Date</u>	<u>Invoice Amount</u>	<u>Account</u>	<u>Amount</u>
36757	2014 FORD E150 REPAIRS		04/22/2026	2,840.07		
			REPAIR & MAINT SVCS-OPERATIONS--		01 E 005 810 000 000 350	2,840.07
05/05/2026	60745	Check	VIKING ELECTRIC SUPPLY	39.16		
<u>Invoice Number</u>	<u>Description</u>		<u>Invoice Date</u>	<u>Invoice Amount</u>	<u>Account</u>	<u>Amount</u>
S010224064.001	BLANKET PO FOR 2025-2026 FISCAL YEAR		04/24/2026	39.16		
			REPAIR SUPPLIES-OPERATIONS--		01 E 005 810 000 000 420	39.16
				<b>Total:</b>		<b>\$414,113.66</b>

### T261101 Summary

Type	Count	Amount
Regular	72	414,113.66
ACH Checks:	0	0.00
Wire Transfers:	0	0.00
Epayables:	0	0.00
<b>Total:</b>	<b>72</b>	<b>\$414,113.66</b>

## Board Packet

AP Run: VRT261101 — Post Date: 2026-05-05 — AP Run Type: V

Austin Public Schools ISD 492

Check Date	Check Number	Payment Type	Name	Check Amount	
05/05/2026	59333	Check	OWENS, COLLEEN M	-779.95	
<b>Invoice Number</b>	<b>Description</b>	<b>Invoice Date</b>	<b>Invoice Amount</b>	<b>Account</b>	<b>Amount</b>
00110270212250020 00129	HYVEE REIM - COOKIES & FROSTING - FUTURE TEACHERS CLUB	12/02/2025	-44.95		
				FOOD-EXT CUR-GROW YOUR OWN STATE GRANT 01 E 310 298 166 000 490	-44.95
120825	LUNCHES FOR FTC FIELD TRIP	12/08/2025	-735.00		
				FOOD-SECONDARY-GROW YOUR OWN STATE GRANT- 01 E 310 211 166 000 490	-735.00
				<b>Total:</b>	<b>-\$779.95</b>

### VRT261101 Summary

Type	Count	Amount
Regular	1	-779.95
ACH Checks:	0	0.00
Wire Transfers:	0	0.00
Epayables:	0	0.00
<b>Total:</b>	<b>1</b>	<b>-\$779.95</b>

## Board Packet

AP Run: VRT261101 — Post Date: 2026-05-05 — AP Run Type: R

Austin Public Schools ISD 492

Check Date	Check Number	Payment Type	Name	Check Amount	
05/05/2026	60746	Check	OWENS, COLLEEN M	429.26	
<b>Invoice Number</b>	<b>Description</b>	<b>Invoice Date</b>	<b>Invoice Amount</b>	<b>Account</b>	<b>Amount</b>
00110270212250020 00129	HYVEE REIM - COOKIES & FROSTING - FUTURE TEACHERS CLUB	05/05/2026	44.95		
				FOOD-EXT CUR-GROW YOUR OWN STATE GRANT 01 E 310 298 166 000 490	44.95
120825	LUNCHES FOR FTC FIELD TRIP	05/05/2026	384.31		
				FOOD-SECONDARY-GROW YOUR OWN STATE GRANT- 01 E 310 211 166 000 490	384.31
				<b>Total:</b>	<b>\$429.26</b>

### VRT261101 Summary

Type	Count	Amount
Regular	1	429.26
ACH Checks:	0	0.00
Wire Transfers:	0	0.00
Epayables:	0	0.00
<b>Total:</b>	<b>1</b>	<b>\$429.26</b>

## Board Packet

AP Run: W261101 — Post Date: 2026-05-04 — AP Run Type: R

Austin Public Schools ISD 492

Check Date	Check Number	Payment Type	Name	Check Amount	
05/04/2026	202003800	Wire Transfer	TUITION EXPRESS	1,346.16	
Invoice Number	Description	Invoice Date	Invoice Amount	Account	Amount
APRIL 2026	TUITION EXPRESS FEES FOR APRIL 2026 PAID IN MAY 2026	05/04/2026	1,346.16		
	FEEES FOR SERVICES-KIDS KORNER--COM ED	04 E 500 570 000 321 305			1,346.16
<b>Total:</b>					<b>\$1,346.16</b>

### W261101 Summary

Type	Count	Amount
Regular	0	0.00
ACH Checks:	0	0.00
Wire Transfers:	1	1,346.16
Epayables:	0	0.00
<b>Total:</b>	<b>1</b>	<b>\$1,346.16</b>

## Board Packet

---

### Summary by Fund

Austin Public Schools ISD 492

---

<b>Fund</b>	<b>Total</b>
01 - GENERAL FUND	1,785,512.28
02 - FOOD SERVICE FUND	201,974.71
04 - COMMUNITY SERVICE	42,953.29
05 - CAPITAL EXPENDITURES	30,290.68
11 - SITE & CO-CURRICULAR	6,280.73
12 - AUSTIN AREA CONSORTIUM	3,411.43
55 - PROFESSIONAL DEVELOPMENT FUND	1,194.31
66 - ATHLETICS	1,216.30
88 - STUDENT ACTIVITY	4,272.15
	<hr/>
	<b>\$2,077,105.88</b>

**INDEPENDENT SCHOOL DISTRICT NO. 492 - AUSTIN  
MARCH 2026 TREASURER'S REPORT**

	BALANCE BEGINNING OF MONTH	DEBITS	CREDITS	BALANCE END OF MONTH
<b>TREASURER'S BOOKS</b>				
<b>CASH</b>				
01 GENERAL FUND	183,219.58	10,851,969.05	8,280,520.36	2,754,668.27
05 CAPITAL OUTLAY	(860,293.33)	3,365.52	238,589.98	(1,095,517.79)
11 SITE AND COCURRICULAR	595,597.45	26,504.50	43,366.74	578,735.21
12 AUSTIN AREA CONSORTIUM	(17,127.66)	0.00	2,852.70	(19,980.36)
55 PROFESSIONAL DEVELOPMENT FUND	28,574.34	31,825.62	566.80	59,833.16
66 ATHLETICS	103,231.71	4,042.83	5,450.86	101,823.68
88 ACTIVITY FUND	204,499.17	1,929.80	6,425.30	200,003.67
02 FOOD SERVICE	1,336,666.92	897,887.72	343,852.84	1,890,701.80
04 COMMUNITY SERVICE	1,472,055.35	344,823.46	275,264.75	1,541,614.06
06 CONSTRUCTION FUNDS	40,110.43	6.71	6.71	40,110.43
07 DEBT SERVICE	785,736.15	0.00	0.00	785,736.15
08 TRUST FUND	48,568.98	0.00	0.00	48,568.98
18 CUSTODIAL FUNDS	0.00	8,265.76	8,265.76	0.00
20 INTERNAL SERVICE FUND	1,036,149.48	1,219,272.26	1,459,566.84	795,854.90
<b>TOTAL CASH</b>	<b>4,956,988.57</b>	<b>13,389,893.23</b>	<b>10,664,729.64</b>	<b>7,682,152.16</b>
01 CASHIER'S OFFICE PETTY CASH	3,000.00	0.00	0.00	3,000.00
01 CERTIFICATES OF PURCHASE - US BANK	1,909.94	48.41	0.00	1,958.35
06 2025 LEASE PURCHASE - MN TRUST	6.71	0.00	6.71	0.00
<b>INVESTMENTS</b>				
01 OPERATING INVESTMENTS - MN TRUST	24,255,236.94	13,304.27	956,600.00	23,311,941.21
01 SCHOLARSHIP INVESTMENTS	8,197.07	0.69	0.00	8,197.76
08 SCHOLARSHIP TRUST INVESTMENTS	70,314.56	2.67	0.00	70,317.23
45 OPEB TRUST INVESTMENTS	126,522.90	389.98	0.00	126,912.88
88 ACTIVITY FUND	20,002.03	0.00	0.00	20,002.03
<b>TOTAL INVESTMENTS</b>	<b>24,480,273.50</b>	<b>13,697.61</b>	<b>956,600.00</b>	<b>23,537,371.11</b>
<b>GRAND TOTAL PER TREASURER'S BOOKS</b>	<b>29,442,178.72</b>	<b>13,403,639.25</b>	<b>11,621,336.35</b>	<b>31,224,481.62</b>

<b>BANK ACCOUNTS</b>	<b>BALANCE PER BANK STATEMENT</b>	<b>OUTSTANDING CHECKS</b>	<b>DEPOSITS NOT SHOWN ON BANK STATEMENT</b>	<b>OTHER RECONCILING ITEMS</b>	<b>BALANCE PER TREASURER'S BOOKS</b>
BREMER/OLD NATIONAL - SAVINGS	10,028.96	0.00	0.00	0.00	10,028.96
BREMER/OLD NATIONAL - ICS CASH SWEEP	239,143.60	0.00	0.00	0.00	239,143.60
BREMER/OLD NATIONAL - MAIN	1,069,730.17	(440,532.34)	5,487.62	41,704.31	676,389.76
MSDLAF+ Liquid Class	0.00	0.00	0.00	0.00	0.00
MSDLAF+ MAX Class	5,626,932.29	0.00	0.00	0.00	5,626,932.29
MN TRUST OPERATING ACCOUNT	1,129,657.55	0.00	0.00	0.00	1,129,657.55
MN TRUST CAPITAL FACILITY BONDS 2025A	0.00	0.00	0.00	0.00	0.00
CASHIER'S OFFICE PETTY CASH	3,000.00	0.00	0.00	0.00	3,000.00
CERTIFICATES OF PURCHASE - US BANK	1,958.35	0.00	0.00	0.00	1,958.35
2025 LEASE PURCHASE - MN TRUST	0.00	0.00	0.00	0.00	0.00
OPERATING INVESTMENTS - MN TRUST	23,311,941.21	0.00	0.00	0.00	23,311,941.21
SCHOLARSHIP INVESTMENTS	8,197.76	0.00	0.00	0.00	8,197.76
SCHOLARSHIP TRUST INVESTMENTS	70,317.23	0.00	0.00	0.00	70,317.23
OPEB TRUST INVESTMENTS	126,912.88	0.00	0.00	0.00	126,912.88
ACTIVITY FUND	20,002.03	0.00	0.00	0.00	20,002.03
<b>BALANCE</b>	<b>31,617,822.03</b>	<b>(440,532.34)</b>	<b>5,487.62</b>	<b>41,704.31</b>	<b>31,224,481.62</b>

RECONCILIATION OF TREASURER'S BALANCE WITH BANK

0.00



**DATE:** May 11, 2026

**TITLE:** 2026-2028 APA Contract Approval

**TYPE:** Action

**PRESENTER:** Katie Baskin, Executive Director of Academics and Administrative Services

**BACKGROUND:**

Contract negotiations with the Austin Principal Association (APA) began in January 2026 and concluded on February 25, 2026. The process spanned two months of collaborative discussions focused on addressing staff needs, district priorities, and long-term sustainability, ultimately resulting in a mutually agreed-upon contract.

The following are highlights of the proposed 2026-28 contract:

1. Article 7: created insurance caps
2. Article 10: reduced the age of retirement with benefits to the age of 60
3. Article 10: decreased the amount of district covered insurance for retirees
4. Article 10: increase the amount of 403B to \$5,500 per year
5. Salary Schedule: increase doctoral stipend to \$3,000 per year added a lead principal stipend
6. Salary Schedule: added a lead principal stipend

The two-year total package for this proposed agreement is \$301,366.78. Using the Minnesota School Board Association's costing formula, the two-year percentage increase is 11.42%

Superintendent, Dr. Joey Page supports this recommendation.

**RECOMMENDATION:** I recommend approving the proposed 2026-28 APA collective bargaining agreement.



**DATE:** May 11, 2026

**TITLE:** Contract with Arux for Facilities Scheduling and Community Education

**TYPE:** Action

**PRESENTER:** Jennifer Lawhead

**BACKGROUND:**

Austin Public Schools currently lacks a consistent, efficient districtwide process for scheduling school facilities. To address this need, a team of district staff, representing multiple departments, collaborated with community stakeholders to examine current challenges and identify potential solutions.

The team explored the guiding question: *How can we implement an effective and efficient districtwide process, supported by new software, that ensures space-specific needs are met and that communication is clear, timely, and consistent for all internal and external stakeholders?*

As part of this work, the team reviewed district operational needs, community use requirements, and evaluated three software platforms designed to support facility scheduling and community education programming.

**RATIONALE:**

Based on this review, the team recommends moving forward with Arux. This platform enables centralized facilities scheduling, significantly reduces the risk of double-booked spaces, and improves access to accurate, timely information for both internal users and community members. The tool supports clearer communication and more efficient coordination for facility use and program participation across Austin Public Schools.

**RECOMMENDATION:**

Approve the use of Arux, a comprehensive cloud-based platform designed to modernize and streamline the management of after-school programs, childcare services, enrichment courses, and facility scheduling across the district.



**DATE:** May 11, 2026

**TITLE:** Kelly Services

**TYPE:** Information

**PRESENTER:** Sue Stark, Director of Human Resources

**BACKGROUND:**

During the 2025–2026 school year, the district established a Substitute Task Force to address the ongoing need for consistent classroom coverage by substitutes. The task force includes 38 members representing teachers, administrators, clerical staff, and substitute teachers. The purpose of the group was to examine the district’s current substitute system and identify opportunities to strengthen and improve substitute coverage across the district.

The task force focused its work around the guiding question: *How can the district strengthen systems, staffing, and support to ensure consistent classroom coverage in ways that are sustainable, effective, and student-centered?*

As part of this work, Kelly Services presented information to the task force regarding substitute staffing solutions. Their presentation highlighted strategies to improve substitute fill rates, expand the substitute pool, increase consistency through training, and create a more predictable and reliable daily coverage system.

**RATIONALE:**

The district continues to experience challenges in securing consistent substitute coverage, which can impact student learning, staff workload, and daily school operations. Improving substitute staffing systems is necessary to ensure classrooms are consistently supported by qualified personnel and to reduce disruptions caused by unfilled absences.

Through the work of the Substitute Task Force, the district identified a need for stronger systems and additional supports to improve substitute recruitment, training, and placement processes. Kelly Services’ proposal offers potential solutions to these challenges by increasing access to a larger substitute pool, improving fill rates, and providing more structured training and support for substitutes. These improvements would help create a more sustainable, efficient, and student-centered substitute coverage system across the district.

Kelly Services will also provide and fund Red Rover absence management for our school.

**RECOMMENDATION:**

This is information only but will be brought to the board for a vote on May 26, 2026.



**DATE:** May 11, 2026

**TITLE:** Approval of Red Rover for Absence Management and Hiring Software

**TYPE:** Action

**PRESENTER:** Sue Stark, Director of Human Resources

**BACKGROUND:**

Austin Public Schools has used Frontline Education for absence management, as well as recruiting and hiring, for the past 15 years. During this time, the system has undergone very few upgrades, prompting a review of both Frontline and alternative solutions that better meet the district's needs. A committee of 34 APS staff members participated in a product demonstration of Red Rover as part of this review.

**RATIONALE:**

During the demonstration, questions were addressed thoroughly, and overall feedback indicated that Red Rover would be a strong replacement for Frontline.

**RECOMMENDATION:**

I recommend transitioning our absence management and hiring software to Red Rover, with an implementation date of July 1, 2026, for absence management and October 1, 2026, for hiring.



**DATE:** May 2026

**TITLE:** Academics and Administrative Services

**TYPE:** Information

**PRESENTER(S):** Katie Baskin, Executive Director of Academics and Administrative Services

**BACKGROUND:**

The Office of Teaching and Learning oversees curriculum, instruction, staff development, and Federal Title programs for the district.

The Human Resources Office is responsible for employee recruitment and orientation, contract negotiations for all bargaining units, employee relations, student and employee data practices, and staffing with building/program administrators.

**Support and resources to ensure a safe and welcoming learning environment**

- **Principal Professional Development:** Principal professional development focused on strengthening instructional leadership and operational consistency across buildings. Sessions included effective use of EduClimber, connecting high-quality Tier 1 instruction and HITS practices to staff evaluation, and clarifying the principal role as the Special Education LEA representative/designee. Principals also received training on the transition to Microsoft Bookings for conference scheduling to improve family access and efficiency. In addition, guidance was provided on the effective use of Microsoft Teams channels to support communication, collaboration, and document management.
- **Leadership Professional Development:** The District Leadership Team continues its work supporting schools in the development and refinement of their Site Improvement Plans. This work emphasizes coherence across buildings and departments while ensuring specific goals remain responsive to student and staff needs. In addition, the team has begun planning for professional development on artificial intelligence, scheduled for October 2026, to build shared understanding and responsible use. This planning reflects our ongoing commitment to preparing staff for emerging tools that support teaching, learning, and operational effectiveness.
- **Teacher Mentorship:** During the month of April, year 1 teachers and certified staff spent time reflecting on classroom management practices, hints and tips. Our teachers have a wide variety of experiences, and this was a great opportunity for those with experience in the classroom to also share their ideas and strategies. Year 2 teachers did asynchronous learning this month completing a licensure requirement of their choice or need. Year 3 teachers continued their learning work around higher order thinking. They had great conversations about ways to incorporate these ideas into their classroom. May 4 is our last mentorship meeting of the year. All year 1, 2, and 3 teachers come together to celebrate the accomplishments of the year, reflect and provide feedback so that we can continue to evolve the program and meet their needs.
- **Human Resources Dept.:** HR is currently reviewing application and absence management software to identify solutions that better support staff needs while improving efficiency and accuracy in HR processes. This review focuses on streamlining workflows, enhancing user experience, and ensuring the systems align with district operational and reporting needs.
- **Safe and Welcoming Schools:** The District Security Committee spent this year strengthening emergency warning systems with a clear focus on accessible, reliable communication for all staff, including alignment with ADA requirements for employees who are deaf or hard of hearing. The committee reviewed multiple emergency

management platforms through vendor demonstrations and narrowed the options based on functionality, usability, and cost. Current analysis is focused on E3 and Raptor, which offer comparable pricing and strong tools for multimodal emergency communication and reunification support. The committee will continue its evaluation with the goal of recommending a system that enhances safety and provides teachers and staff with clear, actionable guidance during emergencies.

### **Packer Profile for all learners**

- **Grow Your Own:** An exciting time in our GYO program! The students are having some great experiences as they continue to make college visits, most recently to the University of Minnesota. The GYO teacher signing event will feature 9 students and honored educators this year. This event will be held on May 19. We will also award the first GYO Grant Scholarships that evening. There are many summer opportunities coming up for our students, including a new opportunity to collaborate with Riverland and the YMCA. Our future teachers will be working to plan lessons and provide classroom experience for 2 weeks. This opportunity will give students some of their first classroom experiences planning a lesson and leading students through learning.
- **Packer Profile Implementation:** As a part of our ongoing work to support student pathways and career readiness, portfolio development continues across all grade levels at the high school. Seniors have established alumni accounts in SchoolLinks that will activate upon graduation, allowing continued access to college and career resources beyond AHS. Freshmen are actively developing their portfolios and will present later this month, while sophomores continue adding meaningful artifacts and juniors have participated in an assembly focused on portfolio expectations as they prepare for senior year. We are also looking ahead with excitement as Ellis is preparing to launch new Profile-related work next year.

### **District-wide multi-tiered systems of support for all learners**

- **MTSS Implementation:** At the recent District MTSS meeting, leaders reviewed several next steps focused on strengthening systems and alignment across the district. Work is underway to develop a streamlined communication/contact log based on principal feedback, with an emphasis on simplicity and potential alignment with EduClimber. AHS is also defining its SST process for next year to clarify how supports align with BARR and broader student needs, which will be incorporated into district MTSS guidance. In addition, SEL feedback and synthesis are being shared with our MDE partner to inform next steps for 2026–27, alongside initial planning with student support staff representatives. Finally, MTSS growth areas and celebrations will be shared with principals and site leadership teams.
- **READ Act:** Sheila
- **EL Program Review:** Cross-department collaboration is essential to ensuring equitable outcomes for all learners. This year, the Special Education and English Language programs initiated coordinated work focused on strengthening decision-making for students who present with both language acquisition needs and learning concerns. Principals, instructional coaches, school psychologists, and speech-language pathologists collaborated to examine barriers and identify effective practices, with the goal of establishing a clearer, more consistent MTSS pathway for distinguishing between language difference and potential learning disability. This integrated approach supports earlier, more accurate identification and ensures students receive the appropriate instructional and intervention supports.
- **Math Program Review:** A team of eight K–12 APS teachers attended the Minnesota Council of Teachers of Mathematics (MCTM) Conference in Duluth on April 24–25. The conference, titled *Aligning Standards in Context, Culture, and Community*, featured keynote speakers and breakout sessions focused on a range of high-impact mathematics instructional practices. Participating teachers are eager to share and apply their learning as the district begins its work toward adopting the new Minnesota Mathematics Standards and engages in curriculum review as part of this process.
- **GT Program Review:** We hosted our elementary Pi meeting inviting identified students and families to learn more about the Pi program at Southgate Elementary. Parents and students have appreciated the opportunity to learn more about programming. We also celebrate the work of Karla Carroll who has worked to shape the Pi program during her years of service to the district.

## **Excellence in Resource Management**

- Teaching and Learning:
  - After several months of review and collaborative decision-making with internal stakeholders, the Teaching and Learning team recommends the adoption of Lexia PowerUp as the secondary reading intervention curriculum to support implementation of the new state-required literacy program under the READ Act. This program will provide targeted, research-based instruction to address students' literacy needs and support improved reading outcomes across grade levels.
  - CTE teachers are continuing to review curriculum needs for purchase and we are in the process of getting quotes to ensure that we are meeting classroom needs and budget guidelines.



**DATE:** May 11, 20226

**TITLE:** Finance and Operations

**TYPE:** Information

**PRESENTER(S):** Todd Lechtenberg, Executive Director of Finance and Operations

**BACKGROUND:**

The Finance Department includes payroll, employee benefits, accounts payable, accounts receivable, accounting, and fixed asset management. The Executive Director of Finance and Operations oversees Facility Services, Food & Nutrition Services, and Transportation Services.

**Support and resources to ensure a safe and welcoming learning environment**

- Building and Grounds are working to develop a way to print ID cards for our vendors when they are in our buildings, so staff know who they are.
- New copiers are going to be installed during the week of March 9<sup>th</sup> and will allow us to move into phase 3 of Papercut. Thank you to Amy Thuesen and her team for leading this process.
- Developing a plan for security cameras not only installing new ones but also ensuring we have replacement plans in place for current ones.
- Working with the Security Committee to develop a process for notifying staff when we have an emergency that is not people dependent but more system driven.
- Plans have been approved to provide a new and improved office space at Austin High School in the main office and in the administration area. Work will be completed by end of July.

**Packer Profile for all learners**

- The Departments continue to collaborate with colleagues across the district to better learn how we can support the work.

**District-wide multi-tiered systems of support for all learners**

- The Departments continue to collaborate with Teaching & Learning, Special Services, and Building Administration to support and learn about MTSS and the impact it will have on student success.
- Reviewing our state and federal special education budgets to decide the best way to maximize our funding.

**Excellence in Resource Management**

- **Finance Department**
  - Budget process for 2026-2027 school year is underway with some challenging times ahead. Plan is to present in June.
  - Here is the financial review for [March](#). If you have any questions, please contact us.
  - We are starting to review the process of applying for the ASBO Excellence in Reporting, which will be a goal for the 2025-2026 audit along with the 2026-2027 budget.
- **Food and Nutrition Department**
  - The Food Service department is moving to a new menu software system (School Café) towards the end of this school year that will make it easier on our head cooks and staff

for production records and digital menus. The only change to parents will be a new URL, which we will communicate once we are ready to roll the new software out.

- Plans are underway to upgrade the kitchen facilities at AHS, Ellis, Southgate and Neveln

- **Building and Grounds**

- Been meeting with City of Austin and Riverland to develop to ensure that the Austin Public Schools baseball program will have access to the fields at Riverland. These meetings have been productive, and the joint powers agreement is almost ready between City of Austin and Riverland.
- Thank you to Joe and team for all their hard work this past weekend as they successfully deflated and put away the dome for the summer.
- Reviewing the CMA RFP proposals from the four companies that submitted the proposals. Plan is to interview on May 11 with a decision to be made by May 13.
- Summer projects planning is already underway and will be reviewed at the facilities and finance committees in May along with the work session at the end of May.

**DATE:** 05/11/2026

**TITLE:** Information Services

**TYPE:** Information

**PRESENTER(S):** Corey Haugen, Director of Information Services

**BACKGROUND:**

The mission of the Information Services department is to support the district mission and strategic priorities by building capacity through research, evaluation and the application of data to inform school improvement for student success. We provide support and expertise to schools and staff through:

- Providing expertise in the area of measurement and delivering accurate and timely information to building and district staff
- Providing support to district and schools through a systematic evaluation process of district programs
- Reviewing and summarizing data related to student learning and instruction
- Providing professional development on assessment practices, data analysis and interpretation

**Support and resources to ensure a safe and welcoming learning environment**

- Information services is working with all K-12 sites on building out 26-27 rosters and schedules. Here is a brief summary of the process for KG-06 class rostering.
  - **Teacher input is obtained** – teachers provide student feedback through a documentation process that provides targeted notes on students. These teacher inputs include student constraints, students that work well together and students that should be rostered together for specialized services.
  - Information Services takes all the **teacher feedback** and loads it into a **data structure** including data points from the following domains:
    - ✓ Demographic Information
    - ✓ S1 Life Skills Grades
    - ✓ S1 Reading Grades
    - ✓ S1 Math Grades
    - ✓ Attendance Data
    - ✓ Behavior Data, Both Infinite Campus/SWIS
    - ✓ Assessment Data: STAR CAT & CBM's, FAST, ACCESS, CogAT
  - Overall – there are **90+ variables per student** that go into the **algorithm** for clustering/balancing rosters.

- Information Services builds out **balanced classroom rosters** and then site leaders review the rosters with staff to gather **additional feedback and updates**. This is an **iterative process** and will go back and forth until we get the approval from all staff at the site.
- Once stakeholders have approved the rosters, we load the students into the Infinite Campus Student Information System for 26-27 access.

### **Packer Profile for all learners**

- Information Services has been actively working with all our sites to make sure we are prepared for 2026-2027 including new course offerings. We **audit and maintain all courses taught throughout the district** and report student-level grade detail to MDE annually through the MN Common Course Catalog (MCCC) reporting requirements.

### **District-wide multi-tiered systems of support for all learners**

- **MN STATEWIDE ASSESSMENTS (MCA-III/MTAS & MCA-IV/AltMCA) 2025-2026**
  - Teachers and students throughout the district have been working hard throughout the month of April and early May to complete statewide accountability assessments. **Final results from this spring 2026 administration will be available later this summer.** I can however, tell you that as of May 5, 2026 we have completed in total 2,423 MCA-III Mathematics assessments, 2,467 MCA-IV Reading assessments. All told, 4,890 Math and Reading assessments have been completed through May 2. Science testing is scheduled to conclude on May 8. Testing has been going very smooth this year, both from a technical and administrative perspective and we are currently beginning to review embargoed preliminary results in mathematics. Due to the Reading assessment switching to the MCA-IV, prelim results are not available until after standards setting and psychometrical analysis is complete for fall. I would like to thank all the district students, staff and administration for their attention to detail and hard work through another statewide testing season.
- **STAR/FAST Benchmarking Window** opened April 27 and will continue through May 15. This end-of-year assessment period is used to determine year-long growth metrics and help teachers and students see the impacts of their teacher and learning throughout the whole year. We are excited to see positive results later in May when final results are available after May 15.

### **Excellence in Resource Management**

- **SUN Bucks Is Back Again This Summer!**
  - SUN Bucks is an U.S. Department of Agriculture (USDA) Summer Nutrition Program that helps kids thrive by providing families with resources to purchase healthy foods during the summer months.
- **What Is SUN Bucks?**
  - SUN Bucks is an income-based food support program that offers eligible families \$40 per month per child (a total of \$120) during the summer. Funds are provided on SUN Bucks EBT cards and must be used within 122 days of issuance. Families are encouraged to use their benefits as soon as possible to avoid expiration.
- **Who Is Eligible?**
  - Students are automatically enrolled in SUN Bucks if they are directly certified through programs such as:
    - Supplemental Nutrition Assistance Program (SNAP)
    - Minnesota Family Investment Program (MFIP)
    - Food Distribution Program on Indian Reservations (FDPIR)
    - Foster care or Medicaid

- Students identified as homeless, migrant, or runaway (categorically eligible)
- Students with an approved Application for Educational Benefits for free and reduced-price meals through the National School Lunch Program or School Breakfast Program are also eligible.
- **Data Collection Process**
  - The Minnesota Department of Education (MDE) will collect student eligibility data from schools via the SUN Bucks data portal. The Department of Children, Youth, and Families (DCYF) will then issue benefits directly to eligible students.
  - Information Services will be completing the reporting requirements for the SUN Bucks program throughout the summer by uploading eligible student data to the SUN Bucks portal. As of May 5<sup>th</sup>, we have submitted **3,092 total eligible students** that will generate **\$371,040 dollars of EBT disbursements**.
  - Click [here](#) for more information.



**DATE:** 5/11/26

**TITLE:** Special Services Department Update

**TYPE:** Information

**PRESENTER(S):** Dr. Sarah Knudsen, Executive Director of Special Services

**BACKGROUND:**

The Special Services Department includes oversight of the following:

- Special Education Services
- School Health Services
- Student Support Professionals (School Counselors, School Social Workers, School Psychologists)
- Mental Health Supervision and Supports (internal and external)
- Oversight of education at Nexus Gerard's New Dominion School
- Oversight of education at the Austin Albert Lea Area Special Education Cooperative (AALASEC)

**Support and resources to ensure a safe and welcoming learning environment**

- Special Education Mentoring Project has completed three group mentoring sessions
  - Focus of mentoring sessions has been due process requirements and understanding IEP development
  - 10 mentees and 5 mentors participated
  - Mentors and mentees met one time individually between group mentoring sessions
  - Mentoring project is funded by a grant from Region 10

**Packer Profile for all learners**

- The April Special Education Advisory Council (SEAC) meeting was held at the Austin Transition Program location in downtown Austin
  - Staff and students hosted the meeting and provided a welcome
  - Presentation highlighted key program components, including:
    - Work experience opportunities
    - PAES lab
    - Classes held on the Riverland campus

**District-wide multi-tiered systems of support for all learners**

- Cross-department meeting was held to share learning and key insights regarding multilingual learners and identification for special education
  - Participants included:
    - Teaching staff
    - Building principals
    - Teaching and learning staff

- Special education staff, including school psychologists and speech/language pathologists
  - Shared new learning from a fall conference and insights from initial implementation of new concepts
  - Discussion focused on next steps for integrating key components into the MTSS process
- School psychologists met over the last month to plan for service delivery for next year
  - Discussion topics included:
  - Optional service delivery models due to an open position
  - Role clarity and alignment across buildings and settings

### **Excellence in Resource Management**

- Continued efforts to recruit and hire staff
  - Currently recruiting:
    - Special education teachers
    - Speech-language pathologists (SLPs)
    - School psychologists
  - Hired one speech-language pathologist
  - Seeking contracted services for unfilled related service positions (speech and school psychologists)
- Special education paraprofessionals will be hired over the summer months
- Special education Instruction and Inclusion Coaches have been hired
- Assistant Director of Special Education selection process is underway
- Budget planning for the 2026–27 school year is in progress
- Speech Department is developing a process to accurately document workload and caseload:
  - SLPs reviewed and trialed a tool
  - Refinement of the tool is underway
  - Planned implementation for the 2026–27 school year



**DATE:** May 11, 2026

**TITLE:** Technology Services

**TYPE:** Information

**PRESENTER:** Amy Thuesen, Director of Technology

**BACKGROUND:**

Technology Services designs, implements, and supports the technology infrastructure and resources in the district. This includes network and communications, hardware and software, and technology training and integration.

**Technology Advisory Team**

- At the final meeting for the year, the Team discussed:
  - The new AI Policy 625 and how that policy will guide the district forward in its use of Artificial Intelligence.
  - The district's 3-Year Technology Plan, which is now just rounding out Year 2. We reviewed the goals and initiatives that have been completed as well as those that still need work. Next year, this Team will draft a new 3-Year Technology Plan to start in 27-28.
  - An updated student laptop damage and fine process. Members provided valuable feedback on the draft of a new fine structure for 26-27. The goal of this new structure is to simplify and clarify fines assessed for student laptop damage. Members also emphasized the importance of clear communication with families about laptop care and expectations, both at school and at home.
  - Finally, we discussed the rising price of technology hardware and its current and future impact on our district's technology purchases.

**Support and resources to ensure a safe and welcoming learning environment**

- Over the last several months, we have been working toward a major shift in how Tech Services manages account creation and management for staff and students. This work is planned to culminate during June, at which time we will be transitioning our user identity management to OneSync and Entra, moving users out of Active Directory. Functionally, this is a move from on-premises identity management to cloud identity management. This will have a significant impact on our ability to:
  - While logins will remain the same, we will be able to provide users with more timely and accurate access to their Microsoft account and to the email groups and Teams that are used to manage district and building communication and collaboration.
  - Manage security protocols related to account access, password management, and off-site access.

- Reducing reliance on legacy protocols which are harder to secure.

### **Districtwide MTSS & Packer Profile**

- The district is inviting staff members to join a new working group called the Digital Futures Team. This team will not only fulfill the requirements of the AI Committee as outlined by Policy 625 (Acceptable use of AI), but will also be a step toward including instructional staff more fully in the discussion and guidance of APS Technology. This group will:
  - Guide the district's AI objectives and develop, implement, and review district procedures for AI use.
  - Provide feedback for technology-focused professional development.
  - Assist in the review of district adopted technologies (both hardware and software).
  - Have the opportunity to participate in technology pilot testing as new technologies are explored.
  - Provide feedback on district technology replacement cycles and distribution.

### **Excellence in Resource Management**

- While the rise of Artificial Intelligence precipitated the need for a new AI Policy, it's also having an impact on hardware prices. AI is rapidly increasing demand for chips, memory, and data center infrastructure—raising prices and lengthening lead times for both businesses and consumers. We were able to purchase the new 26-27 student devices in December 2025, before prices increased significantly. We also put in our order for new 26-27 staff devices in mid-February. However, we learned in mid-April that the vendor wasn't able to fulfill our order for staff devices and we had to get a new quote for the order—the prices on that quote were approximately 20% higher than our original pricing quote. We then considered our options:
  - Switch vendors, manufacturers, or device models. We saw broad price increases across comparable Windows device options, and it wasn't workable to reduce the functionality of our staff devices. Moving to a non-Windows device with such a short runway to 26-27 would also be challenging for deployment and staff learning.
  - Delay this year's replacement and try to catch up next year. Prices are projected to remain elevated into 2027 and beyond, and may increase further.
  - Extend the replacement cycle for staff devices to five or six years. This would put devices out of warranty before end of use, and older devices tend to perform more poorly and require more costly repairs.

Considering all of the above, we made the decision to move forward with the purchase at the higher per-device price. We will closely monitor pricing and take time during 26-27 to consider our options on device selection and replacement cycle planning.

**DATE:** May 11, 2026  
**TITLE:** APS Site Reports  
**TYPE:** Informational  
**PRESENTER:** Dr. Joey Page, Superintendent

**BACKGROUND:**

The following is a summary of events and items from our sites.

**Austin High School:**

- Support and resources to ensure a safe and welcoming learning environment.
- This month we had the opportunity to recognize our staff for their years of service. It was a great time to reflect on our staff and the impacts they make on a daily bases. Congrats to the following:
  - 5 years of service: Jenna Berg, Robin DeGlavin, Conner Jones, Nick Schiltz.
  - 10 years of service: Tiffany Abbott, Bobbie Stone, Kathy Ewing, Karen Huff, Gabe Nelson, Ashley Wilson.
  - 15 years of service: Yenny Ahumada, Allison Gunderson.
  - 20 years of service: Jens Levisen
  - 25 years of service: Colleen Owens and Nancy Jones.
- Packer Profile for all learners.  
On Wednesday, April 29<sup>th</sup> we had our final Packer Portfolio Lesson and Assemblies. 9th and 10th graders completed work in classrooms while 11th graders had an assembly to review the Packer Portfolio requirements for graduation, learn about Direct Admissions and dive deeper into School Links. Seniors spent the hour with AHS Counselors to review final steps towards graduation and ways to stay connect with us after through School Links.

Senior: <https://app.smore.com/n/rhtma>

Junior: <https://app.smore.com/n/164etr>

- District-wide multi-tiered systems of support for all learners.
- During the final month of the school year, MTSS efforts at Austin High School focused on helping students successfully complete coursework and finish strong. The campus provided structured opportunities, including designated catch-up days and work sessions, for students to complete missing assignments and demonstrate mastery of essential standards.

- Teachers and support staff aligned efforts across all tiers to ensure students had access to the time, support, and resources needed to meet end-of-year expectations. These coordinated supports emphasized accountability, engagement, and persistence, ensuring students had multiple opportunities to remain on track for promotion or graduation.
- Excellence in resource management.  
This was our communication with our school community. End-of-the-Year Student Device Turn-In  
As we approach the close of the school year, we are preparing for our annual End-of-the-Year Student Device Turn-In. It is imperative that all student devices are returned at the end of the year. Devices are collected so they can be serviced, updated, and repaired to ensure optimal use for the Fall 2026 school year.  
Device Turn-In Dates:  
Seniors: Thursday, May 22 at 1:45 PM, during the Senior Walk  
Seniors must turn in both their computer and charger at this time.  
Students in Grades 9–11: Wednesday, May 27, beginning in the afternoon  
All student devices must be turned in. Families will be charged the full replacement cost for any device or charger that is not returned. Prior to turn-in, students should remove all stickers, cases, and personal items from their devices to support an efficient collection process.  
We appreciate everyone’s efforts and cooperation in helping us conduct a smooth and successful end-of-the-year device turn-in. Thank you for your continued partnership as we close out the school year and prepare for the year ahead.

Newsletter: <https://app.smore.com/n/hbjy4>

#### **Austin Online Academy/Austin ALC :**

- Support and resources to ensure a safe and welcoming learning environment.
  - The recent increase in graduation rates across Austin Public Schools is a significant achievement for the district. A closer analysis of last year’s graduating class shows that alternative programming played a substantial role in this success. Of the 352 graduates, 73 students were enrolled in the ALC and 69 students completed one or more courses through AOA during their senior year—meaning over 40% of graduates were directly supported by these programs.
  - This data underscores that alternative programming is not supplemental, but a critical component of the district’s graduation outcomes. The flexibility, individualized support, and strong relationships provided through ALC and AOA create pathways for students to persist and succeed. Continued investment in these programs remains essential to sustaining and growing overall graduation success.
  -
- Packer Profile for all learners.

- The AOA and ALC Experience courses continue to serve as a foundational element of both programs, providing students with structured time and targeted support that directly impacts their overall success. Staff consistently report that students who engage in these courses on a weekly basis demonstrate stronger performance across their other classes. Students also value having a dedicated space to work on essential life and postsecondary tasks—such as completing the FAFSA, building resumes, and applying for jobs—with guided support, making the experience both practical and highly relevant to their future goals.
- 
- District-wide multi-tiered systems of support for all learners.
  - MCA testing for Austin Online demonstrated strong student commitment and family engagement, with 38 students participating across multiple testing dates and locations. Notably, students traveled significant distances—including up to 164 miles one way—highlighting both the value families place on participation and the importance of accessible testing options. The YMCA site proved especially effective, offering a calm, comfortable environment for students and convenient amenities for families, contributing to a positive and supportive testing experience.
  -
- Excellence in resource management.
  - *Last month we had over 67 credits recovered in our night school in the ALC. Counselors are working to support seniors in completing the CLP for summer school if they need additional credits to graduate.*
  -

**Ellis Middle School:**

- Support and resources to ensure a safe and welcoming learning environment.
  - BARR meeting to review strengths and determine next steps in creating Teams for 26-27 school year
  - BARR report from Karen Dunbar:
    - During our second year of implementation, our BARR Coach visits 3 times during the school year. He spends the day with us observing I-Time lessons, block meetings, and our community connect meeting. This is a way for him to see the progress of BARR at Ellis. His last visit was on 3/4/26. A few of his comments are below.
    - Small Block teams assessed grades, honored strengths, and did a respectable job of concentrating on the area of concern.
    - The Big Block team allowed all voices to be heard, shared responsibilities, and consistently found targeted interventions for each student reviewed.

- The Community Connect team zeroed in on new or transitional students, and the school nurse presented great insight that led to a more robust student review.
- The consistency of I-Times facilitation continues to be a bright spot for this school. The I-Time lesson observed had a strong review of House Rules, created opportunities for small group conversations, and demonstrated teachers being flexible with their student population.
- One data point that we are tracking is the **failure rate** by quarter. In the first, second, and third quarters, we are pleased to see a downward trend over the last 4 years.

	2022-23	2023-24	2024-25	2025-26
Quarter 1	11.5%	10.2%	11.10%	9.1%
Quarter 2	13.4%	16.6%	15.5%	11.4%
Quarter 3	15.5%	14.9%	12.5%	11.7%

- Another data point that we are tracking is the number of **behavior referrals**. The number of behavior referrals per month has gone down significantly since we started BARR in the Fall of 2024.

	2022-23	2023-24	2024-25	2025-26
September - April	1657	1879	478	274

- CRT met in March. Review of threat assessments and back-up plans for staff absences during emergencies were discussed.
  - Final student survey (Building wide IGDP goal) to be given to students in May to determine changes from mid-year survey
  - 2 Hour Connect included PBIS expectations in the hallway/classroom/bathrooms and lunchroom. In addition, the spring play Seusical Jr. was livestreamed into the classrooms for student enjoyment. Students who displayed the Packer Core Values were given a PBIS ticket to watch the event live.
  - 6 to 7 tours are scheduled for 5/27 and will include a building tour, Ellis PBIS expectations and introduction to the administrative team
  - Last CRT meeting for the year is scheduled for 5/25
  - First 20 Days of school planning committee developed. Currently reviewing past practices to determine next steps. This will include the planning/implementation of a 7th grade orientation day in August (Potential dates: 8/10, 8/17 or 8/18)
- Packer Profile for all learners.
    - We have started our work with Emily Hovland. She will help coordinate our Career project and our Eagle Bluff trip along with Rod Pesch.
    - Parent Academic Engagement Event on 3/19. Utilization of Title funds to feed our families. Student performances and department led activities throughout

the building. Positive staff/student feedback received. During the 26-27 school year we would like to incorporate this event into an academic day, abbreviate the time frame and expand to include the career project:

- Ellis Scheduling Pathways: [Ellis Course Pathways.docx](#)
- District-wide multi-tiered systems of support for all learners.
  - Dr. Gabrielson/Dr. Cabeen:
    - ALC/Math intervention work for next year is in full swing:
      - Still going to have roughly two sections of "core" ALC students who will have a structured Academic Coach class.
        - Goal planning, LA, SS, Science Support, Social/Emotional learning
      - ♣ We will have a paraprofessional in there full-time to help with the groups.
      - ♣ Student identification process
        - Urgent Intervention, non-SPED, still figuring out EL.
        - Some Intervention kids may be considered.
        - High SGP Fall-Winter
          - May adjust after Spring scores are in for STAR Assessments
      - ♣ Working on student identification as well and resources.
    - Reading Intervention pre-planning is complete. This course will be in addition to core content instruction. Students will be enrolled for a full year of services and re-evaluated at the end of each quarter to determine if the level of intensive instruction continues to be necessary.
    - The proposed LIEP has been reviewed as well as the data pulls to make informed decisions regarding placement for students receiving EL services. Co-Taught sections will be reduced, and content area focus shifts (more math and language arts) are occurring.
    - 6 to 7 special services meetings have occurred to assure an appropriate transition and correct classroom placement for students who qualify for services
    - 7 to 8 special services meetings have occurred to assure correct classroom placement for students who qualify for services
    - We have approval and finalized the digital music class for next year.
    - We met with the music department to begin work on new music offerings for the 27/28 school year.
    - Presidential Awards and NJHS Induction is scheduled for 5/21
  - Excellence in resource management.
    - Re-Evaluation of PBIS/STAND for the building for 26-27. Both are stipend positions.
    - Substitute satisfaction surveys will be sent by May 15. Names/emails have been secured to complete the process

Newsletter: <https://app.smore.com/n/fsju0>

### **IJ Holton Intermediate School:**

- Support and resources to ensure a safe and welcoming learning environment.
  - PBIS Celebration – Topic: Community Service. This was very successful we cleaned Todd Park and it was a beautiful day.
  - School Dance: Again, another huge success; attendance was down a little but much fun was had by all!
  - Continued Growth in BARR: We continue to integrate BARR and the BARR lessons into our daily work.
  - Mr. Schara and Mr. Malo started visits to elementary schools to talk with 4th graders.
  - Continued to look at using strengths to realign staff, especially with some leaving.
  - 4<sup>th</sup> grade tours of Holton are scheduled.
  - We continue to work on our first 20 days scripting for next school year.
  - BARR report from Karen Dunbar:
    - During our first year of implementation, our BARR Coach visits 4 times during the school year. She spends the day with us observing U-Time lessons, block meetings, and our community connect meeting. This is a great way for her to see the progress of BARR at IJ Holton. Her last visit was on 4/13/26. A few of her comments are below.
    - Many Small Block teams are nearing their goal to talk about all students by the end of the school year.
    - Teachers come to block meetings prepared to discuss student concerns and collaborate with their peers with new ideas to support each other and their learners.
    - Hundreds of postcards have been sent to students to encourage them in their growth and share their successes with their families.
    - The school is using data to support consistent practices and make adjustments when needed.
    - Below is our progress throughout the year according to our coaching reports from the 4 coaching visits. We have improved significantly in each of the 8 areas throughout the year.

## IJ Holton BARR 2025-26 Progress



- 
- Packer Profile for all learners.
  - Continued movement in the new PLTW Class – Magic of Electrons
- District-wide multi-tiered systems of support for all learners.
  - Continued Growth in BARR
  - HITS professional development is at a stand-still for this year with the canceling of March 20th
    - Have a plan for the continuation of HITS in 2026, thanks to T&L's leadership
  - Looking at a better way to run and schedule meetings using Educlimber.
  - Continued work with Continuous Improvement Plan.
  - Finding the right amount of time for our teachers to meet and dive into the data to drive their everyday curriculum and the interventions.
  - Making PLCs work better for the off-team teachers – EL, SPED, PLTW, Art, PE, and Music
  - Finding the right amount of time for our teachers to meet and dive into the data to drive their everyday curriculum and the interventions.
  - Making PLCs work better for the off-team teachers – EL, SPED, PLTW, Art, PE, and Music
- Excellence in resource management.
  - End of requisitions from staff are all in and were due April 1st.
  - MOU for Chemical Wellness person – need to find.
  - Rebuilding EOY check out. Making sure we have all assets accounted for

- All hiring at Holton is complete for next year.

Newsletter: <https://app.smore.com/n/2knjg>

### **Banfield Elementary School:**

- Support and resources to ensure a safe and welcoming learning environment.
  - Banfield hosted a Family Glow Night on April 30 with over 400 attendees, creating a strong turnout and positive community engagement. We provided a variety of interactive activities for families, including glow-in-the-dark bingo, silent disco, and glow bowling. We provided pizza for families but ran out within the first hour.
  - Banfield celebrated Teacher Appreciation Week with multiple activities throughout the week to recognize staff efforts. Meals and treats were provided through the combined support of administration, BPTC, and local community organizations. Appreciation efforts focused on acknowledging staff dedication and maintaining a positive school culture as the year progresses.
    - Student created a video to say Thank You
      - [Student Video](#) – Link
    - Over the past several months, families have had the opportunity to show their appreciation through a survey shared through the monthly S'more
      - [Banfield Family Responses](#) - Link
- Packer Profile for all learners.
  - As we look to expand the artifacts that students upload to SeeSaw, our non-classroom teachers have started to create a plan for the 26-27 school year.
- District-wide multi-tiered systems of support for all learners.
  - Continued refining processes for referring and supporting struggling students through the Supplemental Support Team and Intensive Support Team
  - Focused on improving clarity, consistency, and effectiveness of intervention systems to better meet student needs through appropriately tracking student interventions
  - This year has been a growth period for Professional Learning Communities (PLCs). Ongoing work to ensure teams are using data to guide decisions and monitor student progress. Increased focus on strengthening PLC structures, including the use of consistent processes, data analysis, and purposeful agendas. We've identified areas for continued improvement and are making adjustments to strengthen PLC practices for the upcoming school year
- Excellence in resource management.
  - We've wrapped up purchases for this year. However, we do have a few family nights yet this year that may have some last minute purchases
  - Currently we are fully staffed for next year and working through room assignments.

Newsletter: <https://app.smore.com/n/6bu1f>

## **Neveln Elementary School:**

- Support and resources to ensure a safe and welcoming learning environment.

We welcomed our newest Neveln Knights on Tuesday, May 5th during our Kindergarten Welcome Event. We had 26 incoming Kindergarten students attend with their families and loved ones. Students enjoyed games, coloring, stories, and a bus ride with the Kindergarten teachers. Families participated in an informational session with Mrs. Hemann to learn more about Neveln Elementary and the Kindergarten experience. Families also had the opportunity to sign up for Packers in Training and schedule Kindergarten screening appointments.

It was a wonderful opportunity to connect with and welcome our new Neveln families into our Knight community.

We are excited to invite families to our Spring Family Event on Thursday, May 14th from 4:00–6:00 PM. This outdoor event will feature free food, ice cream, games, and more — a fun-filled evening is planned for the whole family.

- Packer Profile for all learners.

Throughout the year, our students have been uploading work into Seesaw to demonstrate their growth in reading and math. Families are encouraged to regularly review their child's learning artifacts and celebrate their progress together. If families are having trouble accessing their child's Seesaw account, they are encouraged to contact their child's classroom teacher for assistance with access codes.

Our Neveln Knights are also participating in several field trips this spring to help explore future career pathways and connect classroom learning to real-world experiences.

- Kindergarten students are visiting the Hormel Nature Center in May.
- 1st Grade students are visiting the Hormel Historic Home and Hormel Nature Center in May.
- 2nd Grade students are visiting Oxbow Park and Zollman Zoo in Byron, Minnesota on May 7.
- 3rd Grade students are visiting the Minnesota Zoo in Apple Valley, Minnesota on May 11.
- 4th Grade students are participating in the Canoemobile experience, touring IJ Holton, and visiting the Mower County Historical Society on May 13.

- District-wide multi-tiered systems of support for all learners.

Our students in Grades 3 and 4 recently completed the MCA assessments in reading and math. We are proud of our Neveln Knights for their hard work, perseverance, and positive attitudes during these important assessments.

Our schoolwide attendance goal is 90% or higher each week. This goal represents our commitment to ensuring every student has access to the learning, relationships, and opportunities they deserve.

#### Attendance Highlights:

- Week of April 1–3: 91.1%
- Week of April 6–10: 93.82%
- Week of April 13–17: 93.2%
- Week of April 21–24: 93.3%
- Week of April 27–May 1: 94.08%

Overall Attendance Rate for April: 93.4%

- Excellence in resource management.

We continue to closely monitor student enrollment numbers as we plan for the 2026–2027 school year. This ongoing review process helps ensure that staffing allocations, classroom placements, and resources are aligned to best meet the academic, behavioral, and social-emotional needs of our students.

Our goal is to responsibly manage resources while maintaining strong learning environments and providing high-quality support for all Neveln Knights.

Newsletter: <https://app.smore.com/n/b23th>

#### **Southgate Elementary School:**

##### **1. Support and resources to ensure a safe and welcoming learning environment.**

Our Gators are working towards a dance party event when we fill up our GATOR Swamp. We are also hosting a welcome event for incoming Kindergarten families this Thursday to make sure we are welcoming our future Gators!

As the school year closes out, we have multiple activities plan to help build a welcoming environment for students including our Schoolyard Bash, our Nature Center and Canoemobile trips, and 4th grade send off.

##### **2. Packer Profile for all learners**

Our teachers continue to load artifacts into SeeSaw for students and families to see learning and growth over the school year. Also, many of this year's field trips will have elements of real life career exploration that we will capitalize on for students to be able to see themselves as productive members of or own community. We are very excited for these opportunities!

### **3. District-wide multi-tiered systems of support.**

Each week, our student support teams continue to meet to discuss the needs of our students whether it is in the typical classroom or for those who may need additional supports. Members of our support teams are part of the district MTSS teams and continue our own learning.

We are now in our last assessment window and will use the data to adjust our classroom practices and how we provide services to students who may need additional supports. Our teams are also discussing how we can get the next school year off and running with a great start.

### **4. Excellence in resource management.**

Teachers and our district office spent several weeks working through rosters drafts to make sure that our classrooms are balanced and give students and staff the best opportunity for success.

We are also beginning some necessary resource management for next year including looking at space needs, student programming and starting to develop a building schedule.

Newsletter: <https://app.smore.com/n/kdg59-gator-gazette>

### **Sumner Elementary School:**

- **Support and resources to ensure a safe and welcoming learning environment.**

On May 7th, we welcomed our incoming kindergarten students and families to Sumner Elementary! We were excited to host 43 future Sumner Star students and more than 70 family members and caregivers for an evening filled with important information, fun activities, and exciting first experiences at Sumner.

Caregivers spent time with Ms. Rollie and had access to valuable resources to help prepare for a successful start to the school year, while our youngest learners enjoyed time in a kindergarten classroom, meeting new friends, and experiencing what it means to be a Sumner Star. We are so excited to partner with our families and help our newest Sumner Stars get off to a strong start this fall!

We are looking forward to our Spring Concert showcasing our incredibly talented kindergarten (9:00 AM), first grade (9:45 AM) and fourth grade (10:45 AM) students. These concerts will occur on Friday, May 15.

- **Packer Profile for all learners.**

Exploring Career Pathways Through Field Trips! This spring, our students are taking learning beyond the classroom through a variety of engaging field trips that connect to real-world career pathways. Our kindergarten and first grade students will be heading out to the Nature Center, where they'll explore the wonders of the natural world and learn about careers in environmental science and conservation. Our fourth grade students will participate in the

Canoemobile experience—an exciting, hands-on opportunity to learn about water ecology and outdoor education. They'll also visit the Historical Society at the fairgrounds to dive into local history and explore careers in museum curation, preservation, and public service. These experiences help spark curiosity and broaden students' understanding of the many ways learning connects to future opportunities!

Check out your child's learning progress in reading, math and writing by navigating to our Seesaw application. If you haven't logged into Seesaw yet, reach out to your child's teacher to get connected!

- **District-wide multi-tiered systems of support for all learners.**

Growing Greatness Through Strong Data-driven Systems and Relationships! We continue to engage in powerful work at Sumner to support every student—academically, socially, and emotionally—through our MTSS (Multi-Tiered System of Supports). MTSS is a framework that helps us identify and respond to each student's needs by providing layered levels of support. Whether a student needs enrichment, targeted intervention, or additional social-emotional guidance, MTSS helps ensure no one slips through the cracks. We value the importance of building strong relationships and maintaining clear, consistent data-driven systems to help all students thrive. We're excited to carry this learning forward as we continue growing greatness at Sumner!

Our third and fourth graders have successfully completed the MCA assessments—great job to all of them! Next, we'll begin our spring benchmark assessments. These assessments help us track student growth over the course of the year and identify key success criteria for end-of-year outcomes. This information is essential in guiding our instruction and celebrating how far our students have come.

- **Excellence in resource management.**

We continue to monitor student enrollment numbers to determine staffing needs for the upcoming 26-27 school year.

Many of our staff applied for grants through the Austin Public Education Foundation. Sumner was awarded over \$14,000 in grants this year from this foundation. I know we are already rich in collaboration, trust, collective efficacy, and an unwavering commitment to our students, and this grant opportunity has only added to our wealth. We are excited to see the meaningful impact it will have on our students in the upcoming year.

Newsletter: <https://app.smores.com/n/6cjp5>

## Community Learning Center:

- Support and resources to ensure a safe and welcoming learning environment.
  - Early Childhood Screening and Packer in Training representatives were present for the Kindergarten Welcome Events.
  - We hosted a new family meeting for incoming preschool students on April 30<sup>th</sup> at the CLC. We were pleased to meet so many new families and to welcome them to Austin Public Schools.
- Packer Profile for all learners.
  - Summer Community Education summer offerings will be publicized this month. We look forward to sharing all the great enrichment opportunities for youth this summer.
  - Preschool graduation is planned for May 27 and 28. During graduation students share their desired career path in addition to sharing their learning through songs.
  - The CLC will be hosting our final family event of the year on May 14<sup>th</sup> with music by Will Sings Songs (AHS Alumni), kite flying, and root beer floats.
  - Summer Kids Korner will be open at Woodson this year. Many in and out of town field trips are planned for fun and learning.
  - Several of our Adult Learning students are participating in the “para class” through ABE. As part of this course they are required to observe in classrooms. We are so pleased that several of our students have chosen to do their observations at the CLC.
- District-wide multi-tiered systems of support for all learners.
  - Readers Café, a summer reading program, will be offered the month of June at Woodson during summer lunch.
  - Kids Korner will be partnering with Austin Aspires this summer to offer tutoring for students who are interested while they attend School Age Child Care.
  - Our early childhood team received training on “Handwriting Without Tears”, designed to inform educators about best practices in building early writing skills.
- Excellence in resource management.
  - Representatives from the Minnesota Community Ed Association will be in the district May 13<sup>th</sup> to conduct interviews with community members, school district employees, and parents about the Community Education programs in Austin. They will be preparing recommendations for improvement in the form of an audit available in June. We look forward to receiving this information.

Newsletter: [May Family SMORE](#)



THE HORMEL FOUNDATION

# Austin Assurance Scholarship

[www.austinassurance.org](http://www.austinassurance.org)





## Students

- **Grade Level** Presentations
- Career Pathway **Newsletter**
- **SchoolLinks** Scholarship List
- **Scholarship Workshop** (Jan)
- Riverland **Campus Tours**
- Riverland **Prep Day**
- Riverland **Multicultural Day**
- **Back to School** Assembly
- Day to Day **Conversations/Accessibility**
- **College/Career Fairs**
- "The **Tree**"
- Digital **Message Boards**
- Materials in **English and Spanish**



## Families

- Parent **Newsletter**
- **Social Media** Posts
- Digital **Message Boards**
- Information on **school website**
- **Flyers** in MCA Score Reports
- **Awards Night Recognition**
- Virtual **Scholarship Night** (Dec)



## Staff

- **Staff Meeting** Presentation
- Digital **Message Boards**
- Volunteer Hour **Reminders**



# High School Initiatives (APS)

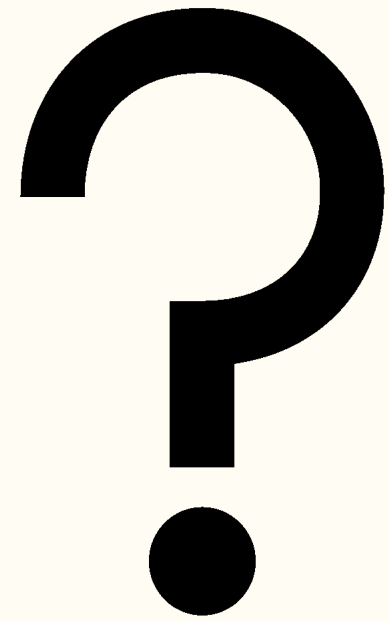

# How can we increase the number of volunteer opportunities in the community?

**Volunteer Remind Group**

Join Ms. Carlson's Volunteer Opportunity Remind Group - TEXT @34kd64g to 81010 to get Ms. Carlson's texts about volunteer opportunities

This graphic features a light blue background with a white speech bubble containing the text. It is decorated with yellow starburst icons and a dotted pattern.

**GET CONNECTED**

United Way

**VOLUNTEER NOW**

This graphic has a blue and white color scheme with orange horizontal stripes. It features the United Way logo in the center, flanked by the phrases "GET CONNECTED" and "VOLUNTEER NOW" in large, bold, blue letters.

**STUDENT SERVICE WEEK**

A chance for students to volunteer locally!

**JUNE 24 - 28**

PROUDLY ORGANIZED BY:  
United Way  
RIVERLAND Community College

MONDAY 6/24	PARENTING RESOURCE CENTER
TUESDAY 6/25	RACHEL'S HOPE
WEDNESDAY 6/26	RIVERLAND COMMUNITY COLLEGE
THURSDAY 6/27	HORMEL NATURE CENTER
FRIDAY 6/28	MOWER COUNCIL FOR THE HANDICAPPED

SCAN THE QR CODE TO REGISTER ON GET CONNECTED TODAY!

QUESTIONS? CONTACT US!  
507-437-2313  
ksr@uwmower.org

This graphic is a vertical poster with a blue and orange color scheme. It lists the dates and locations for Student Service Week, includes logos for United Way and Riverland Community College, a QR code, and contact information.

# Scholarship History Roadmap

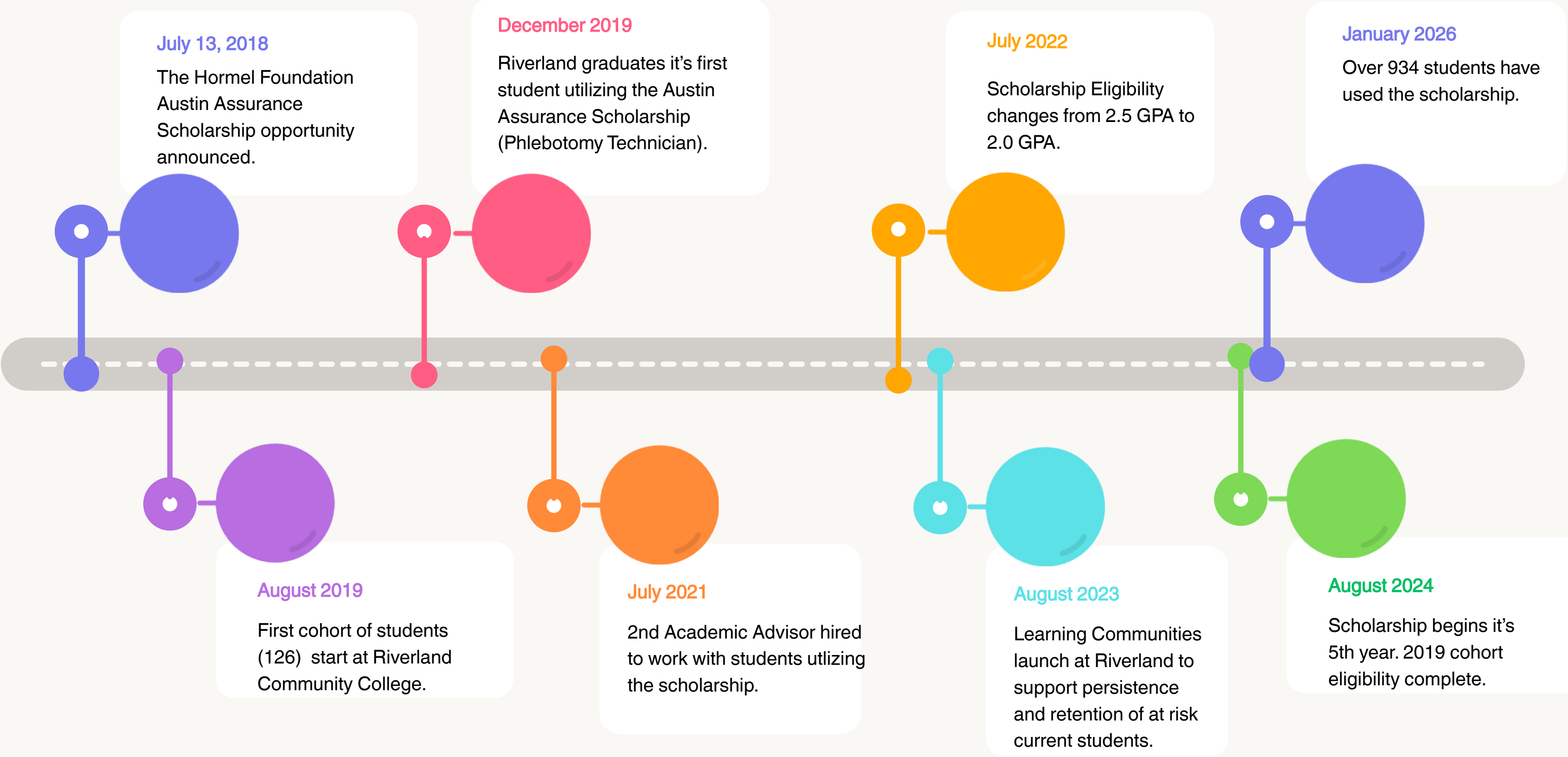

# Student Lifecycle

8th Grade and beyond

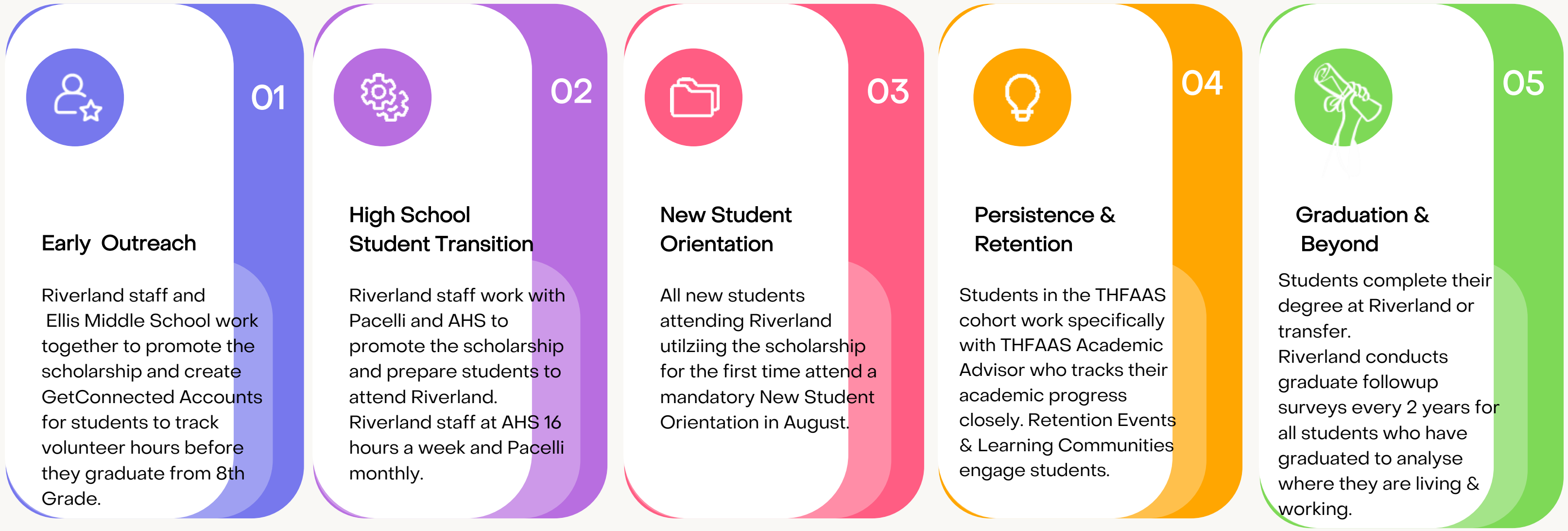

# Impact

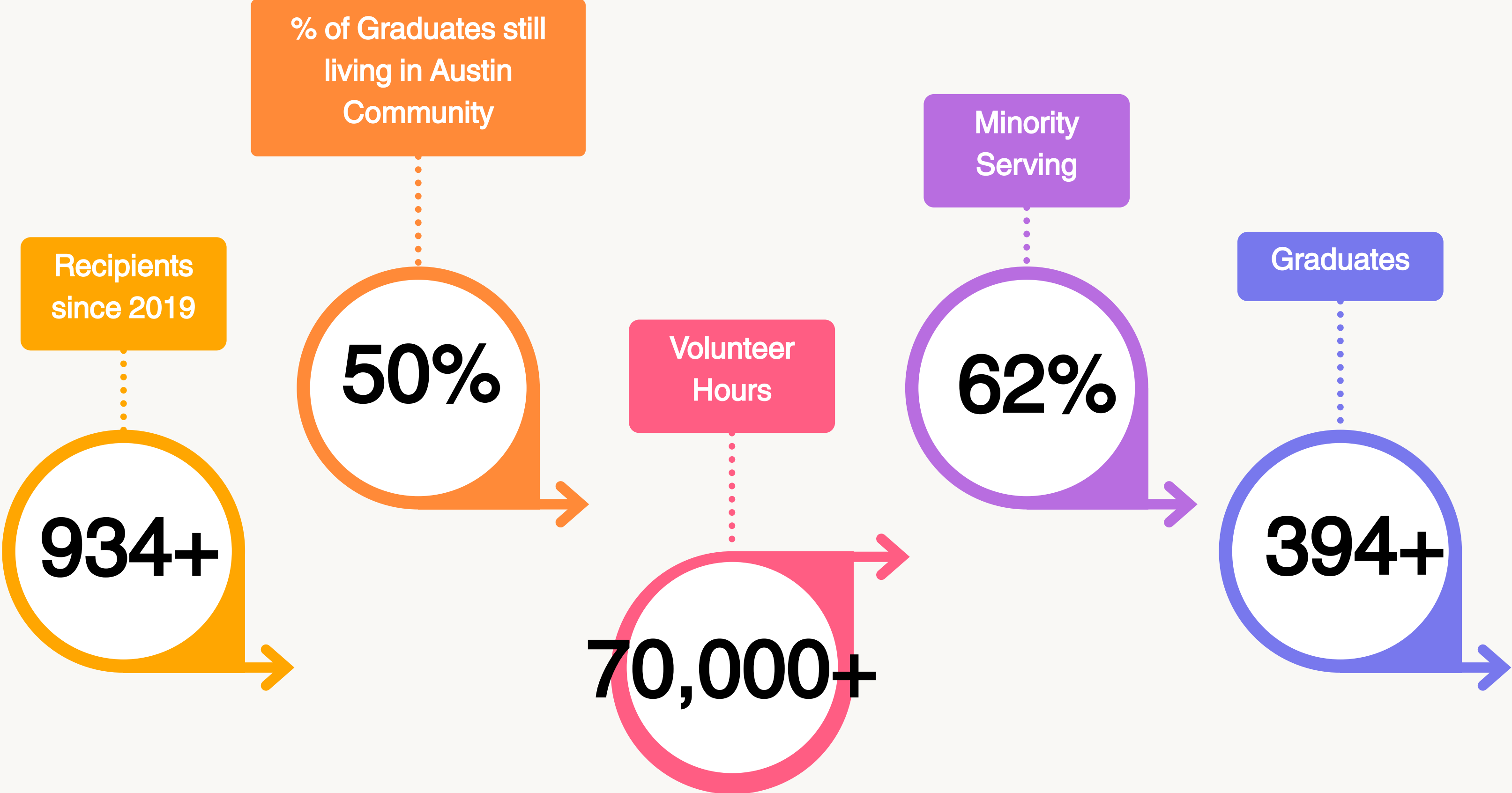

# FIRST FALL ENROLLMENT FOLLOWING HS GRADUATION

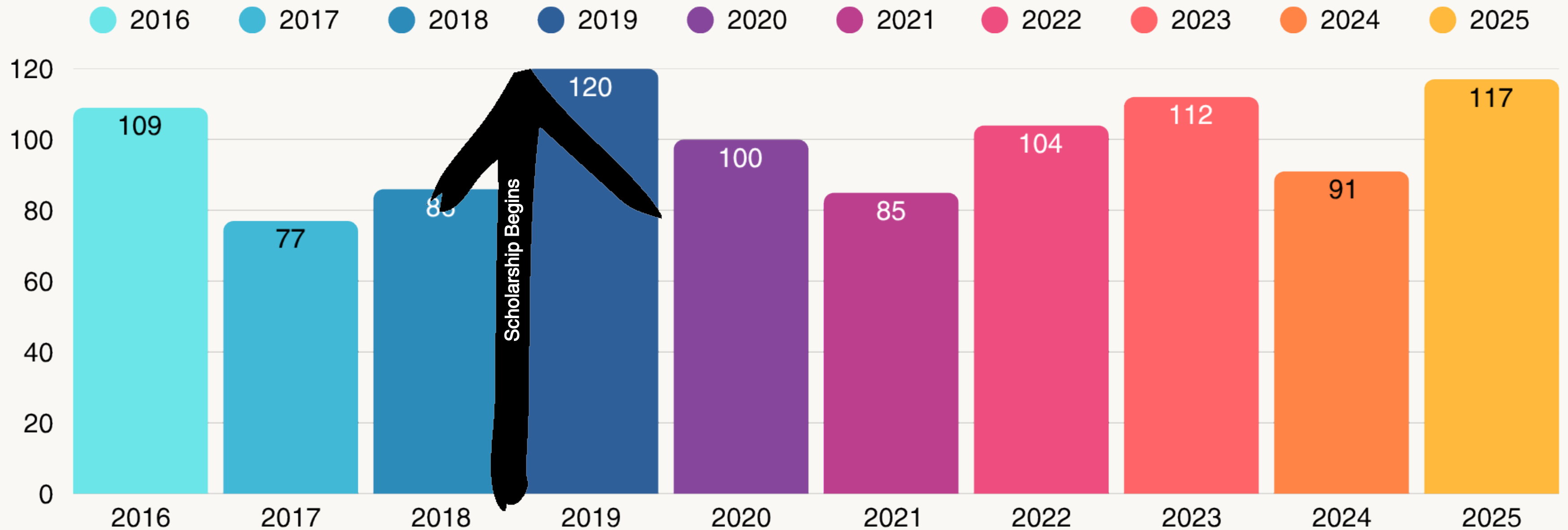

# FIRST YEAR ENROLLMENT FOLLOWING HS GRADUATION

● 2019 ● 2020 ● 2021 ● 2022 ● 2023 ● 2024 ● 2025

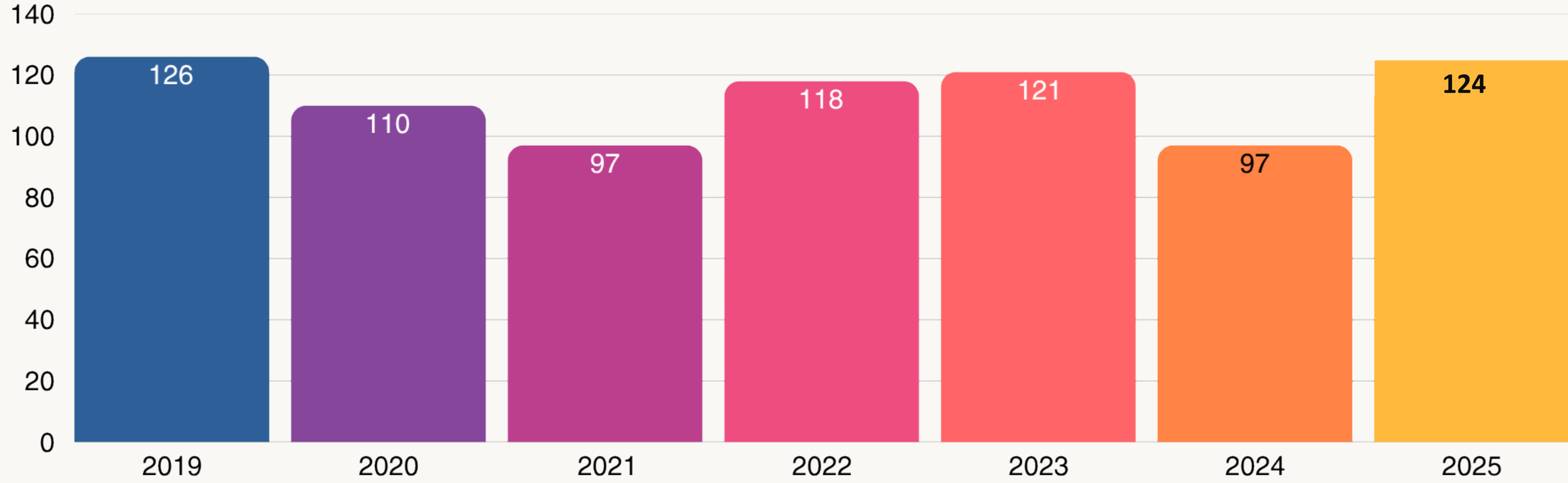

# Riverland Support for Enrollment

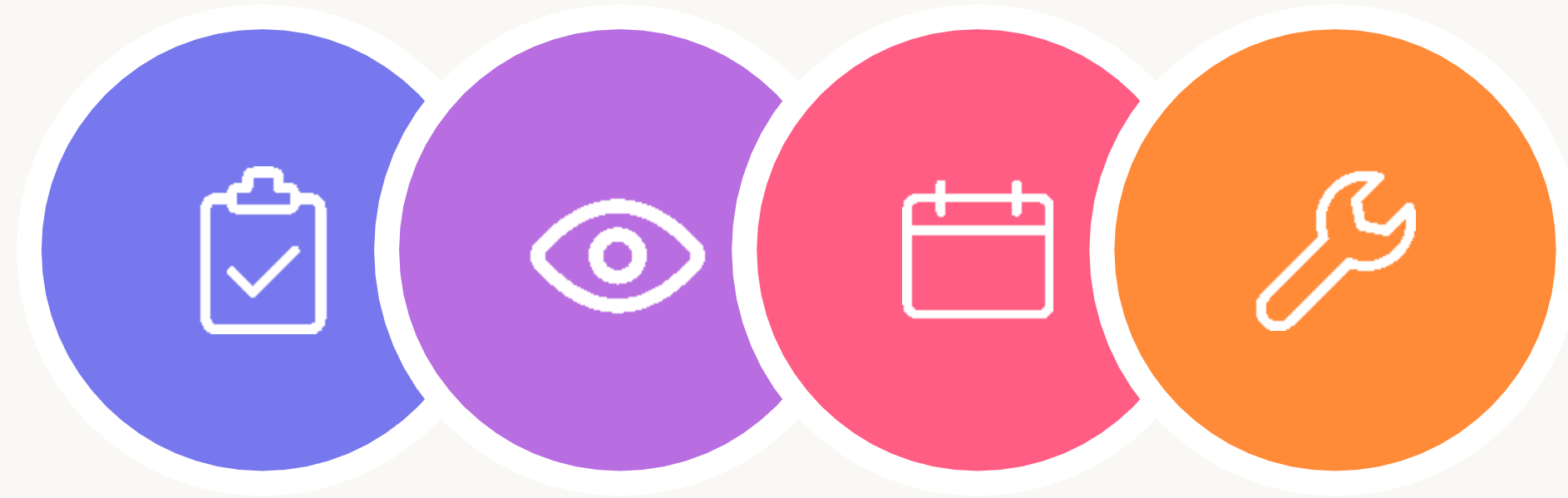

**8th Grade GetConnected Accounts**

Over 75% of all 8th grade students have GetConnected Accounts created before they graduate from 8th Grade to track volunteer hours!

**Packer Profile Classes**

The Hormel Foundation Austin Assurance Scholarship is built into the 9th grade Packer Profile Class curriculum - what it is, how to qualify for it, and volunteer connections.

**Staff Embedded at AHS**

Riverland admissions, financial aid and advising staff are embedded at AHS for 16 hours every week in our own office space.

**Senior Communication**

Riverland communicates scholarship eligibility with students in the fall of their senior year and continues to work with them continuously through the summer to enroll at Riverland.

# Riverland Support for Enrollment

Staff  
Embedded at  
High Schools

Financial Aid  
Support

1:1 Student  
Follow-  
up/Meetings

Career  
Opportunity  
Exploration

Riverland  
Prep Day

Multi-  
Cultural  
Admissions  
Support

In-Person  
Orientation  
(including  
families)

Awards Night THFAAS Recipients



# STUDENT DEMOGRAPHICS

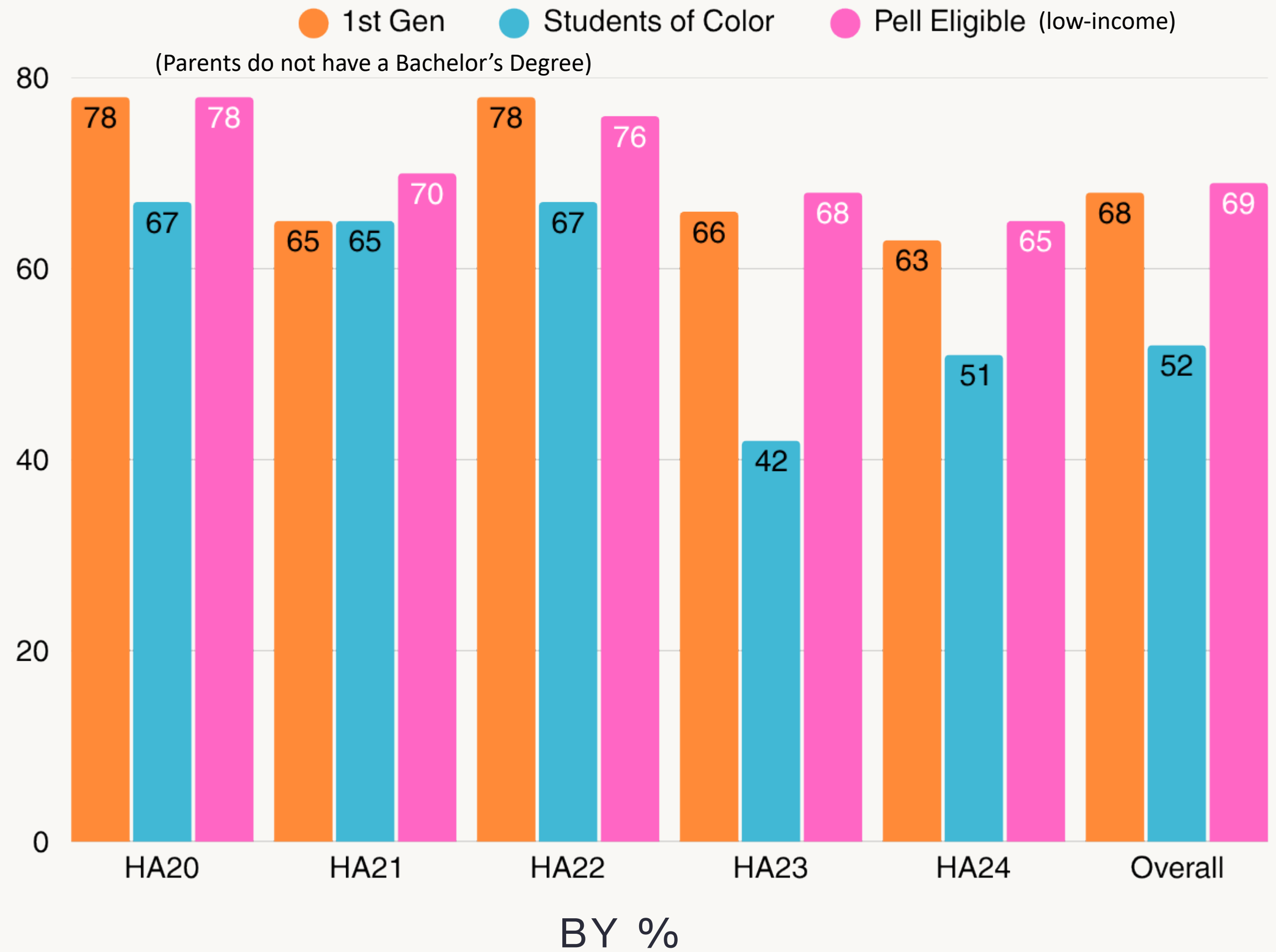

## First Semester Retention Rates

% of continued enrollment from fall to spring semester

● HA19 ● HA20 ● HA21 ● HA22 ● HA23 ● HA24

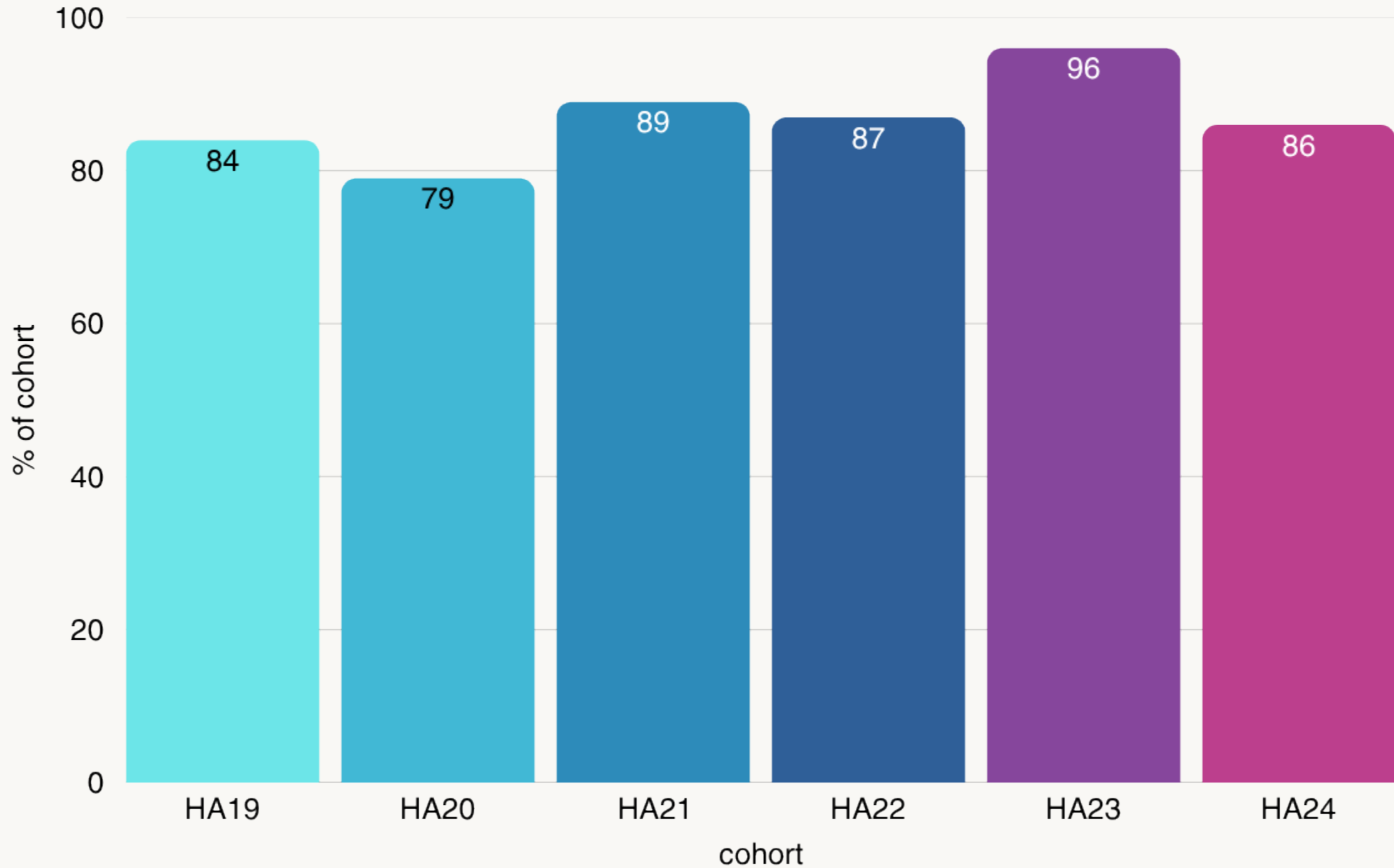

THFAAS Students are retained at an average of

# 20%

## HIGHER

than Riverland's general population

# Fall to Fall Student Retention Rates

% of students retained from year 1 to year 2

HA19 HA20 HA21 HA22 HA23

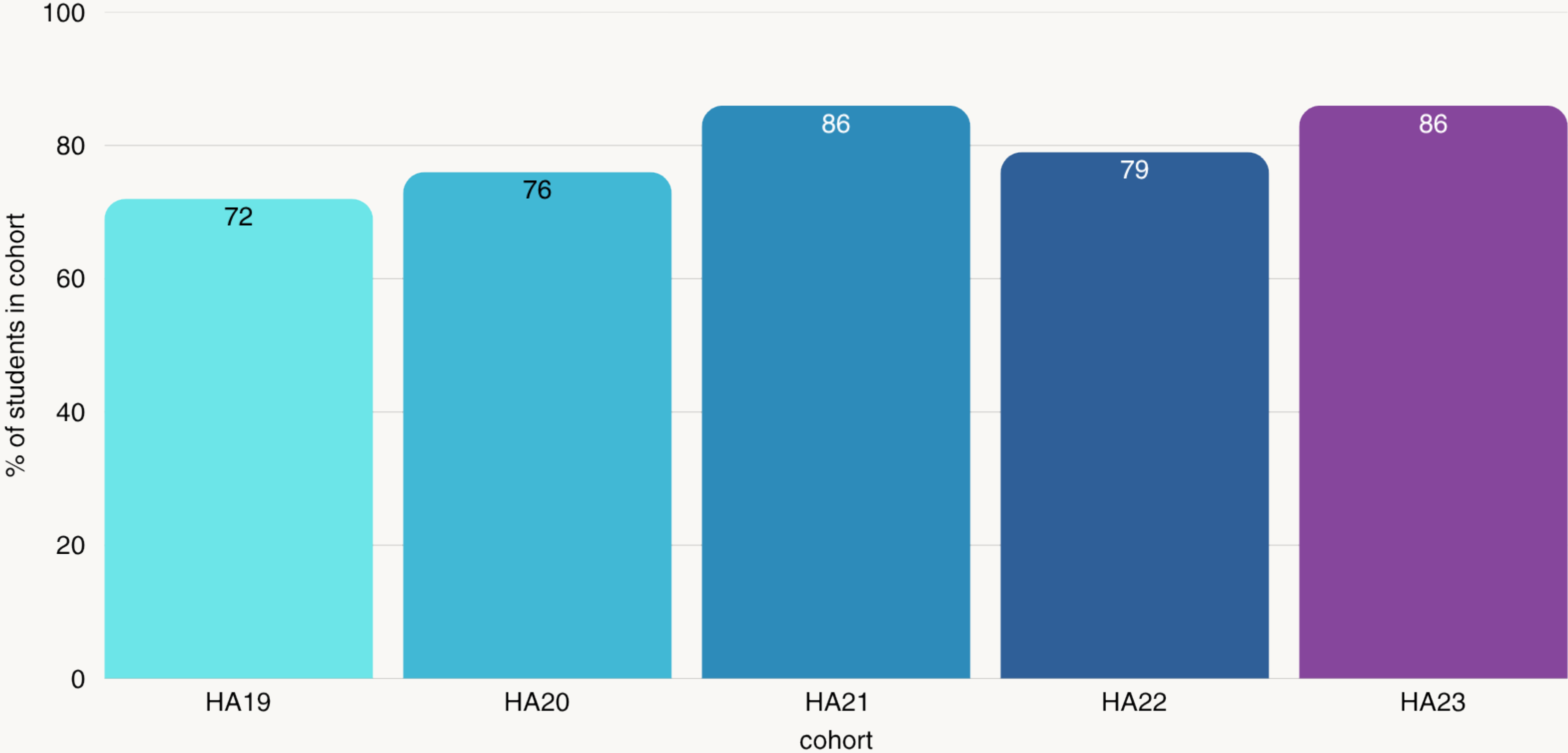

# Riverland Graduates

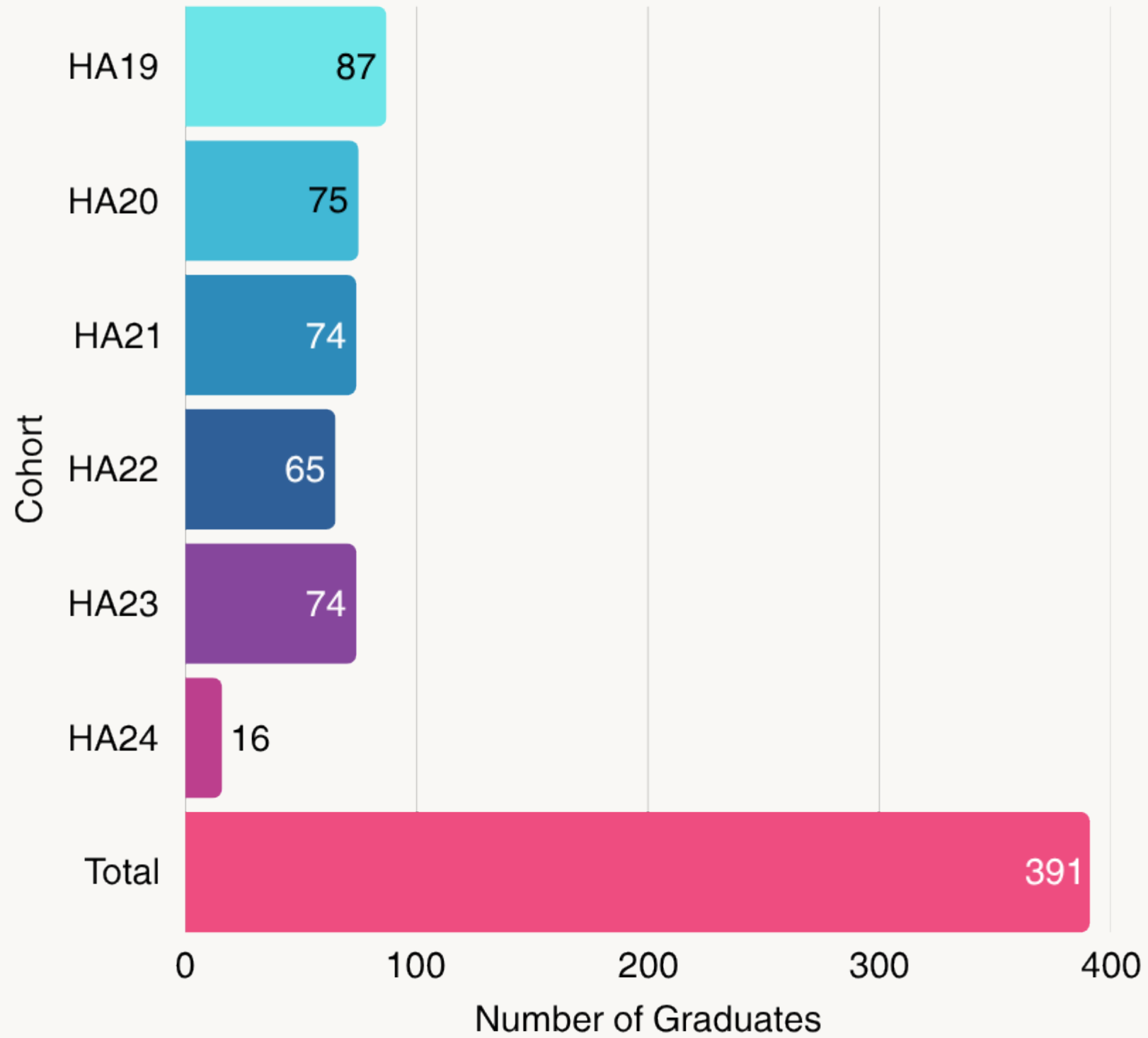

\* Data as of end of Spring 2025



# GRADUATE PLACEMENT SURVEY RESULTS

conducted 2024

Graduates Surveyed	291
Response Rate	20%
Respondents living in Minnesota	91%
Respondents living in Austin	68%

Currently employed	39%
Employed in field of study	48%
Employed in Austin	61%

Student Activity Following Graduation	
Continued at Riverland	5%
Transferred to another College/University	61%
Sought Employment	34%



# STUDENT TRANSFER RATES

COHORT	Transfer to 4-yr Inst	Transfer to 4-yr Inst w/in 1yr
HA20	38%	26%
HA21	30%	26%
HA22	28%	18%
HA23	13%	7%



COHORT	Graduated (AA); Did Not Transfer	Graduated (Cert); Did Not Transfer
HA20	14%	17%
HA21	22%	23%
HA22	16%	16%
HA23	3%	6%

## Top Transfer Colleges:

- Winona State University
- Minnesota State Mankato
- University of Minnesota

QUESTIONS?



**PACKER PROFILE**

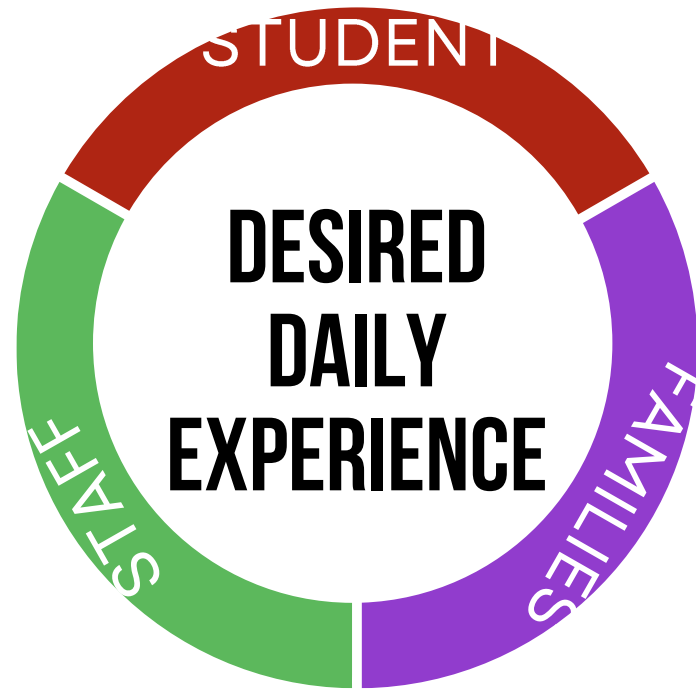

## WHAT OUGHT TO BE

The **Desired Daily Experience** sets the foundation of descriptions of the student, family, and staff experiences *if* the strategic plan is successfully implemented in APS.

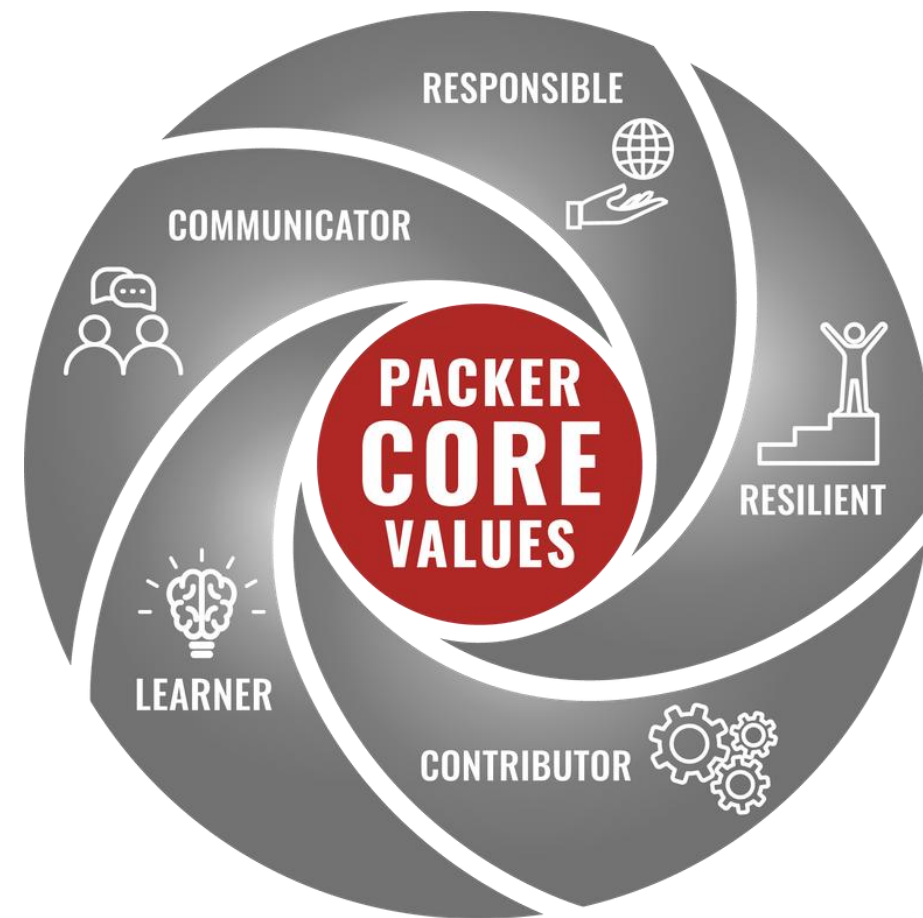

## OUR CORE

(Drivers of Our Words and Actions)

- **Responsible:** Demonstrates accountability to self and others
- **Resilient:** Develops perseverance and self-confidence
- **Learner:** Challenges self to think critically
- **Communicator:** Listens actively and shares learning and experiences
- **Contributor:** Engages as a productive member of the community and global society



## STUDENTS

**I am supported and challenged in my learning and believe I will be successful**

- Teachers and all staff are approachable, listen and respond to my needs
- My teachers have time to talk through and help answer questions or help solve problems I have
- I am trusted to make good choices, be engaged in my learning, and held accountable but not overwhelmed

**I feel that school is safe and that school is challenging and fun**

- ★ ○ I am heard and respected for who I am by school staff and students
- The school and my interactions with students and staff are safe, positive and inclusive
- I enjoy coming to school every day and have time to be with friends during school
- I understand what is expected from me at school
- I am supported in my mental health needs

**I am an engaged learner at school and in our community**

- ★ ○ I have a voice and choice in how and what I learn
- My learning is hands-on, meaningful, challenging and helps me prepare for my future
- My teachers like me and believe in me
- I have teachers and staff that work with me in a way that benefits all students
- ★ ○ I am physically comfortable in the school setting
- This school should be about me not the teachers



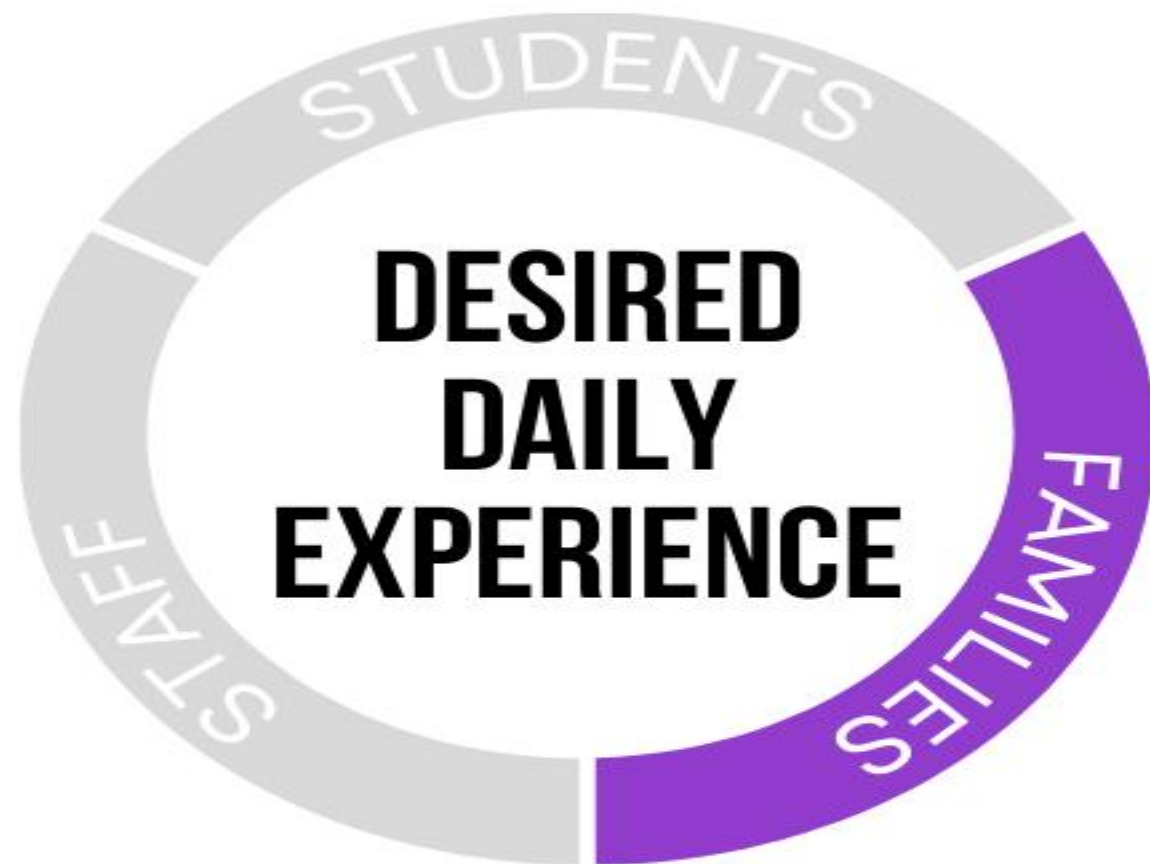

## FAMILIES

**I am part of my child's education and feel welcomed, valued, and respected as a family**

- My child is physically and emotionally safe at school
- My child feels a sense of belonging at school, is cared for, and valued
- My student can voice their thoughts and ideas without being discriminated against so they continue to learn

**My child enjoys coming to school and is safe, included and respected so they are learning every day**

- ★ ○ My child is challenged (not overwhelmed) in learning and development, listened to, and provided choice and voice in learning options
- Teachers know my child well and creates a fun, interactive approach to learning which is responsive to my child's and family needs

**I am engaged in a partnership with my child's school so I know what to do to help my child continue to grow and learn**

- I will feel welcome, informed and encouraged to collaborate with the teachers and staff at the school to help my child grow
- My child's teachers, my child and myself have open communication about their academic progress, social development and well-being
- District and school information is easy to understand and easily accessible
- ★ ○ My child is taught the life skills necessary to be successful in whatever path they choose after high school

# Packer Profile: Packer Portfolio

The Packer Portfolio is a digital collection of evidence that demonstrates learning over time. Student will develop, collect, and reflect on work they complete throughout their four years of AHS and highlight this through their personal Packer Portfolio.

The Packer Portfolio will:

- Demonstrate high levels of knowledge
- Showcase student work from all four years
- Demonstrate the Packer Core Values integration in student work
- Showcase individual strengths and future goals



**PACKER  
PORTFOLIO**

# Packer Profile: Packer Portfolio

## PACKER PORTFOLIO

Students graduating from Austin High School, Austin Area Learning Center, and Austin Online Academy are required to complete a portfolio as a **graduation requirement**. Students will be supported throughout high school in developing their portfolio using SchoolLinks. Below are the portfolio requirements.

*\*\*Beginning with the class of 2027*



### Portfolio Graduation Requirements:

Update Portfolio Page with personal picture and cover photo

Four Years at A Glance

Find Your Path Assessment

Would You Rather Assessment

Document a college visit or career fair participation

Self-management Assessment

Employability Skills Unit

Explore and Create a Career Goal

Brag Sheet (All About Me)

Resume

Artifacts of learning (two per year)

*\*\*Graduation Requirement Completion: December Portfolio Presentation*

*\*\*\*Students missing portfolio items will meet with support staff to update items and present their final.*

# Packer Profile: Packer Core Values



Communicator  
Listens actively and shares learning and experiences.



Learner  
Challenges self to think critically.

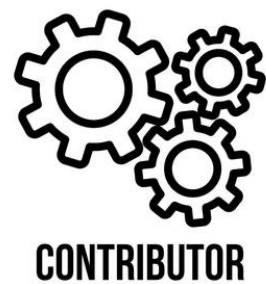

Contributor  
Engages as a productive member of the community and global society.



Responsible  
Demonstrates accountability to self and others.



Resilient  
Develops perseverance and self-confidence.

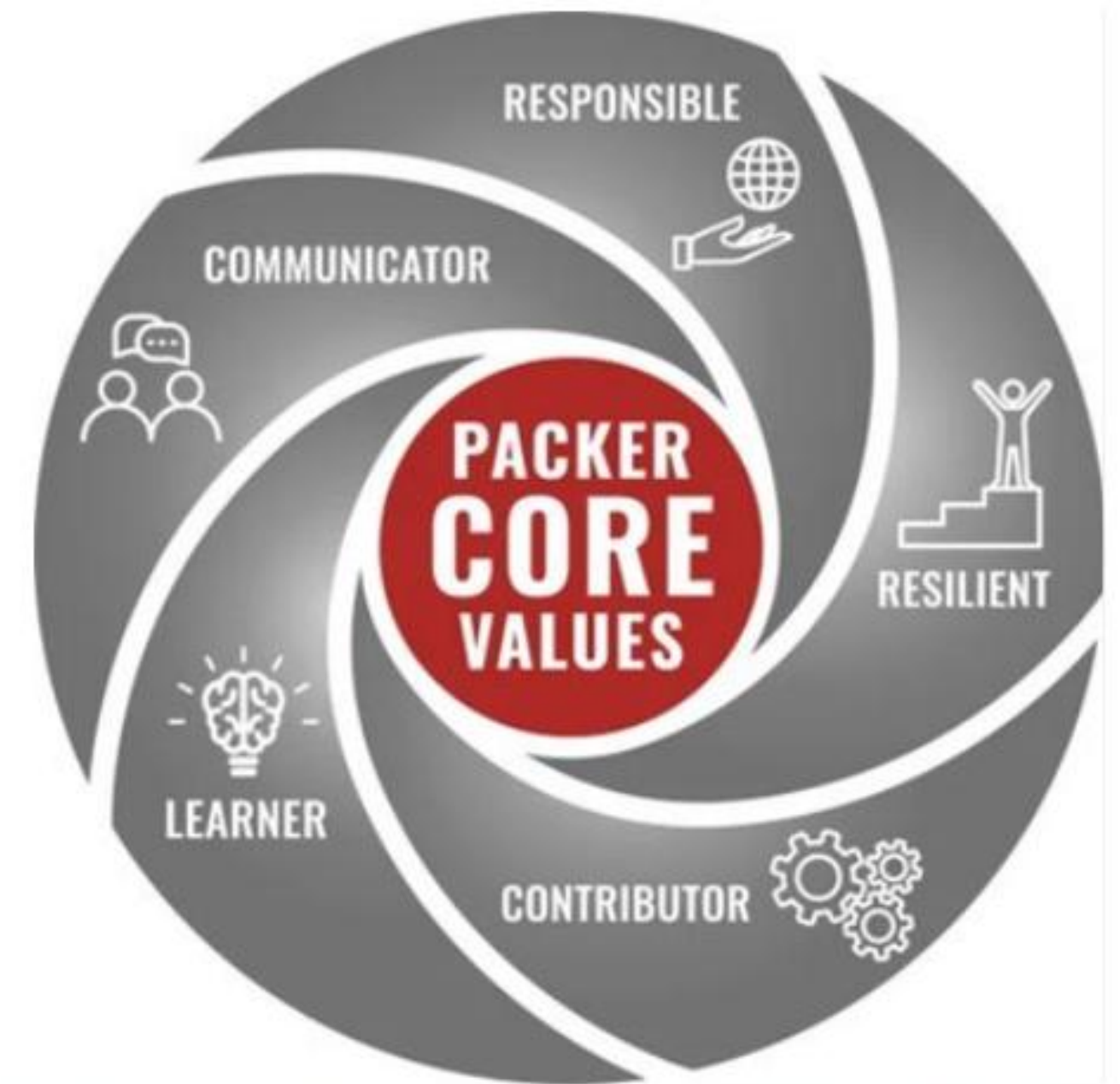



ENGINEERING, MANUFACTURING,  
AND TECHNOLOGY



BUSINESS



EDUCATION, HEALTH SCIENCES,  
AND HUMAN SERVICES



AGRICULTURE, FOOD, AND  
NATURAL RESOURCES



ARTS AND  
COMMUNICATION

# Career Pathways

## SCHOOLINKS FUN FACTS:

- ✓ 7,682 views of our district-added scholarships
- ✓ Over 20,000 logins to the site this year
- ✓ Students register for regional career events
- ✓ Several different career inventories
  - Find Your Path - based on personality traits
  - Would You Rather - based on interests
- ✓ 152 Industry Partner Contacts
- ✓ 95% of AHS/AOA/ALC have completed onboarding into the program
- ✓ 236 seniors already entered their personal email to transition to an alumni account.

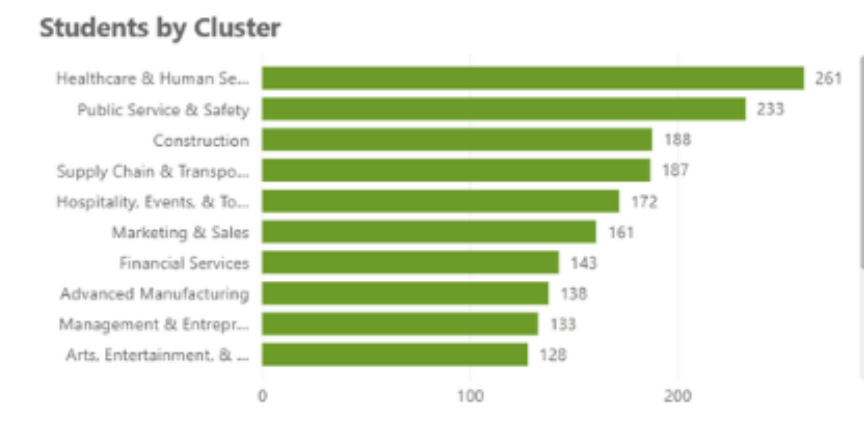
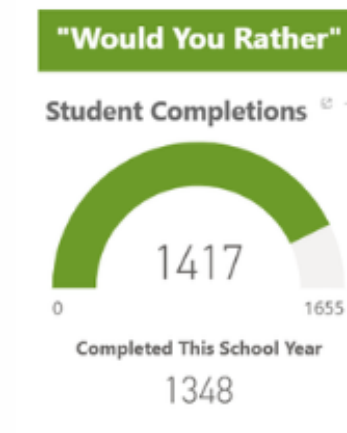
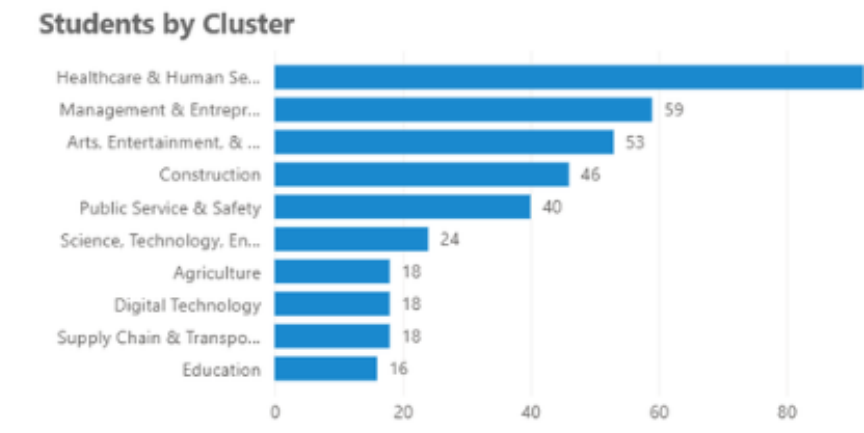

# Student Portfolio

- Talan Hall

# AOA/ALC: Experience Course

**More than a class—it's preparation for life beyond high school.**

All AOA/ALC students participate in an Experience Course each year designed to build real-world readiness.

## **What to Expect:**

**Life Skills:** Managing time, responsibilities, and real-life decisions

**Career Readiness:** Exploring pathways, building employability skills

**Real-World Exposure:** Job shadowing and hands-on experiences

**Future Planning:** College visits and postsecondary exploration

## **Why It Matters:**

This course helps students connect their learning to their future—so they leave high school not just with credits, but with direction.

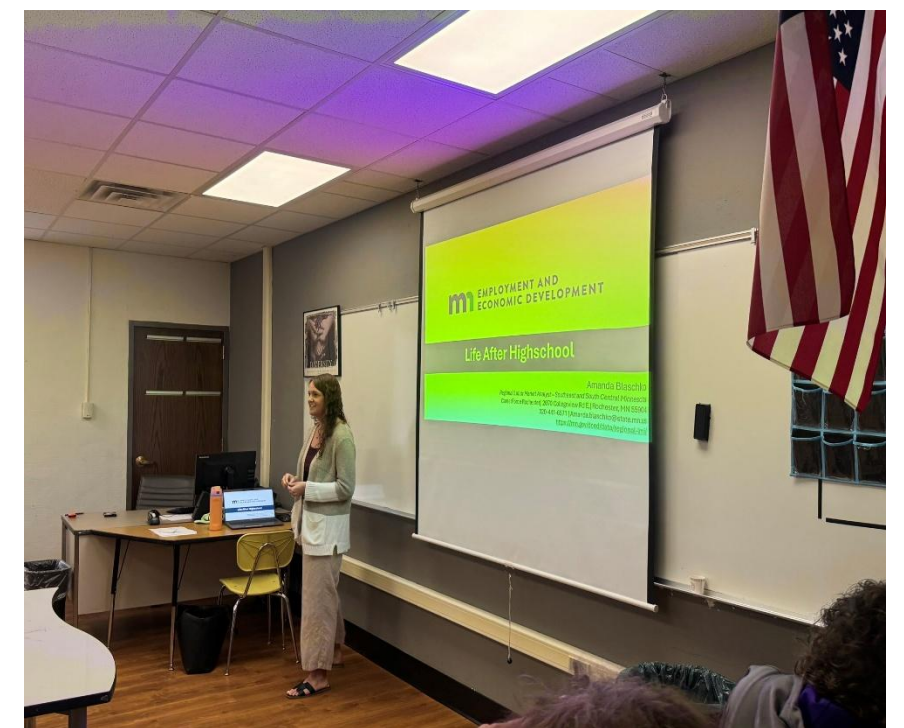
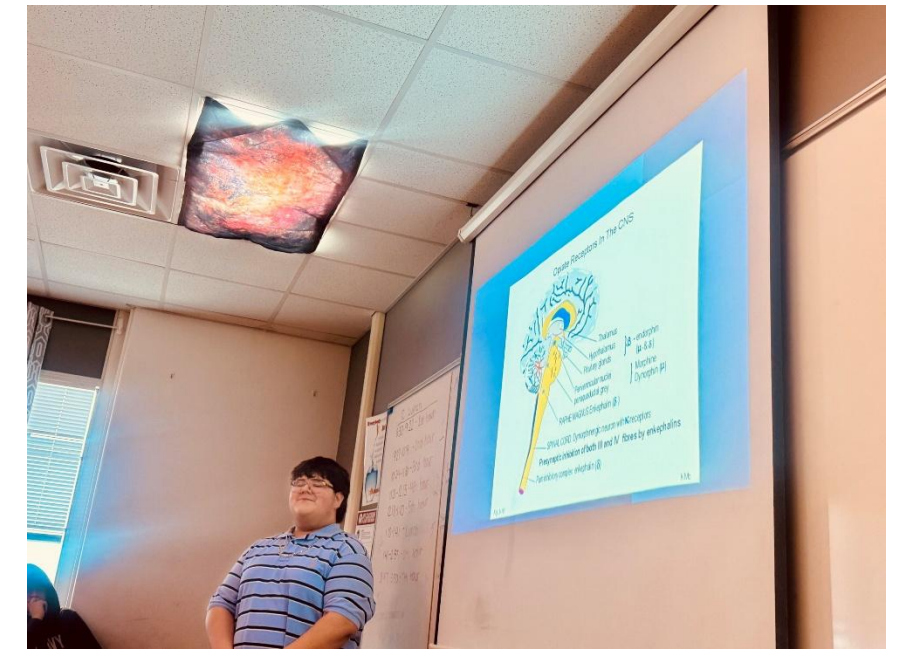



Wrap Up and Questions



**DATE:** May 11, 2026

**TITLE:** Layoff of 3 clerical staff

**TYPE:** Action

**PRESENTER:** Sue Stark, Director of Human Resources

**BACKGROUND:** At the January 5, 2026, board meeting, the board authorized the administration to explore cost-saving measures and operational efficiencies should the district experience a significant change in funding for the 2026–2027 school year.

**RATIONALE:** Based on TeamWorks enrollment projections, the district is projected to decline by approximately 127 students, resulting in an estimated revenue reduction of \$1.75 million. In addition, the district is projected to lose approximately \$2.5 million in compensatory revenue due to changes in the State of Minnesota funding calculation. Combined, these factors represent an estimated \$4.25 million decrease in revenue for the 2026–2027 school year.

**RECOMMENDATION:** Administration recommends that the school board approve the attached resolution laying off 3 clerical staff effective June 30, 2026.

Sarah Nelson	Due Process Clerk
Jolene Brandt	3 <sup>rd</sup> Party Billing
Kellie Fiske	District Cashier

Member P. Young introduced the following resolution and moved its adoption:

**RESOLUTION FOR LAY-OFF OF CLERICAL POSITIONS**

BE IT RESOLVED, by the School Board of Independent School District No. 492, that the following employees be laid off at the end of the 2025-2026 school year effective June 30, 2026:

<u>Names</u>	<u>Position</u>
Jolene Brandt	3 <sup>rd</sup> Party Billing
Sarah Nelson	Due Process Clerk
Kellie Fiske	District Cashier

BE IT FURTHER RESOLVED, that written notice be sent to said employee regarding the lay-off.

The motion for the adoption of the foregoing resolution was duly seconded by Member R. Hartman and upon vote being taken thereon, the following voted in favor thereof: C. Dube, R. Hartman, C. Kroc, D. Leathers, C. McAlister, P. Young and D. Zielke

And the following voted against: --

Whereupon said resolution was declared duly passed and adopted.



# AUSTIN PUBLIC SCHOOLS

INSPIRE • EMPOWER • ACCELERATE

**DATE:** May 11, 2026

**TITLE:** Elimination of Position and Layoff

**TYPE:** Action

**PRESENTER:** Sue Stark, Director of Human Resources

**BACKGROUND:** At the January 5, 2026, board meeting, the board authorized the administration to explore cost-saving measures and operational efficiencies should the district experience a significant change in funding for the 2026–2027 school year.

**RATIONALE:** Based on TeamWorks enrollment projections, the district is projected to decline by approximately 127 students, resulting in an estimated revenue reduction of \$1.75 million. In addition, the district is projected to lose approximately \$2.5 million in compensatory revenue due to changes in the State of Minnesota funding calculation. Combined, these factors represent an estimated \$4.25 million decrease in revenue for the 2026–2027 school year.

**RECOMMENDATION:** Administration recommends that the school board approve the elimination of the District Utility Maintenance position, reassignment of Josh Marshall, and layoff of Chris Moore.

Member \_\_\_\_\_ introduced the following resolution and moved its adoption:

RESOLUTION ELIMINATING DISTRICT UTILITY MAINTENANCE  
POSITION AND LAY-OFF

BE IT RESOLVED, by the School Board of Independent School District No. 492, that the following position of Utility Maintenance be eliminated at the end of the 2025-2026 school year effective June 30, 2026;

BE IT RESOLVED, that written notice will be sent to Josh Marshall regarding the elimination of his position and reassignment;

BE IT RESOLVED, that Chris Moore in the position of Custodian will be laid off;

BE IT FURTHER RESOLVED, that written notice be sent to said employee regarding the termination/lay-off.

The motion for the adoption of the foregoing resolution was duly seconded by Member \_\_\_\_\_ and upon vote being taken thereon, the following voted in favor thereof:

And the following voted against:

Whereupon said resolution was declared duly passed and adopted.



# AUSTIN PUBLIC SCHOOLS

INSPIRE • EMPOWER • ACCELERATE

**DATE:** May 11, 2026

**TITLE:** Unrequested Leave of Absence of one Assistant Principal

**TYPE:** Action

**PRESENTER:** Sue Stark, Director of Human Resources

**BACKGROUND:** At the January 5, 2026, board meeting, the board authorized the administration to explore cost-saving measures and operational efficiencies should the district experience a significant change in funding for the 2026–2027 school year.

**RATIONALE:** Based on TeamWorks enrollment projections, the district is projected to decline by approximately 127 students, resulting in an estimated revenue reduction of \$1.75 million. In addition, the district is projected to lose approximately \$2.5 million in compensatory revenue due to changes in the State of Minnesota funding calculation. Combined, these factors represent an estimated \$4.25 million decrease in revenue for the 2026–2027 school year.

**RECOMMENDATION:** Administration recommends that the school board approve the attached resolution placing Assistant Principal Dr. Raymond Diaz on unrequested leave of absence effective June 30, 2026.

**Resolution Proposing Placement of a Principal  
on Unrequested Leave of Absence**

Member D. Zielke introduced the following resolution and moved its adoption:

BE IT RESOLVED by the School Board of Independent District No. 492, as follows:

That it is proposed that Dr. Raymond Diaz, an Assistant Principal of said District, be placed on unrequested leave of absence without pay or fringe benefits, at the end of the 2025-2026 school year effective June 30, 2026. Said action is taken in accordance Minn. Stat. 122A.40, subd. 10 upon the grounds described in said statute and which are specifically as follows: discontinuance of position, lack of pupils and financial limitations.

BE IT FURTHER RESOLVED, that a notice of proposed placement on unrequested leave, together with a copy of this resolution be forwarded to said assistant principal and that an affidavit of the same be placed in her personnel file with a copy of the notice and resolution.

The motion for the adoption of the foregoing resolution was duly seconded by

R. Hartman and upon vote being taken thereon, the following voted in favor thereof:

C. Dube, R. Hartman, C. Kroc, D. Leathers, C. McAlister, P. Young, and D. Zielke

And the following voted against: --

Whereupon said resolution was declared duly passed and adopted.

May 12, 2026

**HAND-DELIVERED**

Dr. Raymond Diaz

RE: Resolution Proposing Placement on ULA

Dear Dr. Raymond Diaz;

You are hereby notified that at the meeting of the School Board of Independent District No.492 held on May 11, 2026 a resolution was adopted by a majority vote of the School Board, proposing your placement on unrequested leave of absence, without pay or fringe benefits at the end of the 2025-2026 school year effective June 30, 2026. Said action of the School Board is taken pursuant to Minn. Stat. 122A.40, subd. 10 upon the grounds described in said statute and which are specifically as follows: discontinuance of position, lack of pupils and financial limitations.

You are entitled to a hearing before the School Board provided that you make a request in writing within fourteen days after receipt of this notice. If no hearing is requested within such period, it shall be deemed acquiescence by you to the School Board's proposed action.

Sincerely,

Enc. Resolution Proposing Placement of a Principal on Unrequested Leave of Absence

Declaration of Service

STATE OF MINNESOTA

COUNTY OF MOWER

\_\_\_\_\_, states that on \_\_\_\_\_(date) he/she served the attached notice of proposed placement on unrequested leave of absence upon therein named, personally at \_\_\_\_\_in the County of Mower, State of Minnesota, by handing to and leaving with \_\_\_\_\_a true and correct copy thereof.

I declare under penalty of perjury under the laws of the State of Minnesota, including Minn. Stat. § 358.116, that everything I have stated in this document is true and correct.

Executed on May \_\_, 2026 in Mower County, Minnesota:

\_\_\_\_\_

Signature of person making service

**DATE:** May 11, 2026

**TITLE:** Donations

**TYPE:** Action

**PRESENTER:** Todd Lechtenberg, Executive Director of Finance & Operations

**Background:**

School districts receive donations from private individuals, public entities, and trusts on a regular basis. The district implemented School Board Policy 706 – Acceptance of Gifts to ensure compliance with statutory guidance.

**Rationale:**

The school board may receive, for the benefit of the school district, bequests, donations or gifts for any proper purpose. The school board shall have the sole authority to determine whether any gift or any precondition, condition or limitation on use included in a proposed gift furthers the interests of or benefits the school district and whether it should be accepted or rejected. Once accepted, a gift shall be the property of the school district unless otherwise provided in the agreed upon terms.

**Recommendation:**

It is recommended that the following donations be accepted by the school board for the benefit of Austin Public School students.

<b>DONOR</b>	<b>AMOUNT</b>	<b>RECIPIENT(S)</b>	<b>PURPOSE</b>
Cornerstone Church	250.00	More Than Pink Program	Expenses
Austin Rotary Club	375.00	AHS Speech Program	Expenses
Austin Area Retired Educators	100.00	AHS Band	Expenses
Lions Club	200.00	AHS Band	Expenses
Sheryl and Donal Pischke	200.00	AHS Band	Expenses
Kory Robinson	200.00	AHS Band	Expenses
Bob and Carla Pepper	150.00	AHS Band	Expenses
Dave and Connie Simonson	200.00	AHS Band	Expenses
Greg and Jodi Vortherms	300.00	AHS Band	Expenses
On Time Sports	260.00	AHS Athletics	Expenses
Neveln PTC	260.00	YAYA Program	Registrations
Southgate PTC	260.00	YAYA Program	Registrations
Family of Kurt Best/Memorial	500.00	AHS Baseball	Expenses
Neveln PTC	2850.00	Neveln Elementary	Concrete for Neveln's Buddy Bench
American Legion Spam Post 570	50.00	AHS Robotics	Expenses
Zimmerli Family	400.00	AHS Girls Track	General Supplies
Inventory Trading Company	85.00	Boys and Girls Track	Expenses



# AUSTIN PUBLIC SCHOOLS

INSPIRE • EMPOWER • ACCELERATE

**DATE:** May 11, 2026

**TITLE:** LEA Appointment

**TYPE:** Action

**PRESENTER:** Superintendent Dr. Joey Page

## **BACKGROUND:**

Each year the School Board is required to designate the Local Educational Agent (LEA) for the district. This designation is for the oversight of Federal Title funds as well as work with any required district/site improvement plans that may result from AYP (Adequate Yearly Progress) status.

## **RATIONALE:**

The Local Education Agent responsibilities fall under Dr. Katie Baskin's role as Academics and Administrative Services Executive Director. This would be her fourth year as serving as our LEA.

## **RECOMMENDATION:**

I recommend the appointment of Dr. Katie Baskin as the Local Educational Agent (LEA) for Austin Public Schools for the 2026-27 school year.



**DATE:** May 11, 2026  
**TITLE:** Identified Official with Authority (loWA) Designation  
**TYPE:** Action  
**PRESENTER:** Carolyn Dube, Chairperson

**BACKGROUND:**

The Minnesota Department of Education (MDE) has set up a process for assigning an Identified Official with Authority.

The School Board must designate the Identified Official with Authority to authorize user access annually, as well as any time there is a change in the assignment of the Identified Official with Authority. This certification of the Identified Official with Authority designation is in accordance with Minnesota State Access Control Security Standard 1.0. The School Board minutes must clearly specify this role assignment.

**RATIONALE:**

In order to comply with MDE guidelines, Austin Public Schools must designate the Identified Official with Authority for 2026-27.

**RECOMMENDATION:**

It is recommended the School Board of Independent School District #492 designate Dr. Joey Page, Superintendent, to the role of Identified Official with Authority for 2026-27.