

AGENDA
VALLEY CITY COUNCIL
Tuesday, May 13, 2025
City Hall
203 North Spruce
Valley, NE 68064
7:00 PM

1. **Call to Order**
2. **Roll Call**
3. **Pledge of Allegiance**
4. **Proof of Publication**
5. **Visitors/Correspondence**

Anyone desiring to speak on any item or issue not on the agenda or any item on the agenda that does not include a public hearing may do so; but shall be limited to three (3) minutes. Persons should identify themselves by name and address. Persons speaking should not expect the Council to engage in back-and-forth dialogue regarding their comments. Unless an agenda item includes a public hearing, no person may speak during the business portion of the meeting; provided, however, persons speaking during a public hearing are limited to between five (5) and twenty (20) minutes. The public is advised that a copy of the Open Meetings Act is located on the north wall of the Council Chamber, and one copy of all reproducible written material to be discussed at this meeting is available for examination or copying.

6. **Approval of Agenda**
7. **Consent Agenda**

All agenda items on the consent agenda and will be acted on in a single motion. Consent agenda items are being forwarded to the Council Members. Any individual item may be removed by a council member for special discussion and consideration.

7.A. Approve Minutes of April 8, 2025 and April 15, 2025 City Council meetings

7.B. Approve Treasurer's Report

7.C. Approve invoices and additional invoices presented for payment

7.D. Approve April Payroll \$95232.38 and IRA \$3255.36

The City Council reserves the right to enter into an executive session at any time during the meeting, in accordance with the Nebraska Open Meetings Act, even though the closed session may not be indicated on the agenda.

It is the intention of the City Council to take up the items on the agenda in sequential order. However, the City Council reserves the right to take up matters in a different order to accommodate the schedules of the City Council members, persons having items on the agenda, and the public.

7.E. Accept April Keno Receipts \$6829.22

7.F. Accept PeopleService Inc., Report

7.G. Accept minutes and/or statistics of the following boards and/or committees:

- March 13, 2025, Library minutes
- April Library statistics
- March 18, 2025, Planning Commission minutes

7.H. Re-appoint Scott Burke and Jim Tomanek to the Planning Commission (term 05/2028)

7.I. Approve SDL Applications for American Legion Post #58 for July 19, August 16, Sept. 20, Oct. 18, Nov. 15, and Dec. 20, 2025 fundraisers.

8. **2025 Rollin' To Colon Annual Bike Ride consideration and approval of request for recognition and acknowledgment in support of the event on June 29, 2025.**
9. **Valley Suburban Fire District consideration and approval to close North Spruce Street for a training burn on May 24, 2025, from 8:00 a.m. to 3:00 p.m. and request for use of 4 road closure signs from public works, approximate length of road to be closed will be 0.2 miles.**
10. **Valley Days Foundation consideration and approval for sponsorship of Valley Days event and payment of \$5,000 from Keno funds to support Valley Days event on August 8, 9, and 10, 2025.**
11. **Mallard Landing Lake Community/HOA - Rich Hudson consideration and approval of the following requests:**
 - **fireworks display on July 5 and street closure starting at Taylor Circle, continuing down North 269th to Ruggles, from Ruggles picking back upon on North 269th, then turning East on Manderson Street, ending at 267th Circle. The fireworks display would start at approximately 10:00 p.m. for 15-20 minutes. Also, we would like to request a rain date of July 6th in the event of any storms.**
 - **community parade street closure starting at Taylor Circle, continuing down North 269th to Ruggles, from Ruggles picking back upon on North 269th, then turning East on Manderson Street, ending at 267th Circle. The parade would be held from 9:00 a.m. to 12:00 p.m.**
12. **Ginger Cove Block Party - Martha Walker consideration and approval to close Island Circle (house numbers 7–17) on Saturday, June 21, 2025, from 5:00 p.m. - 10:00 p.m. for a luau-themed block party.**

The City Council reserves the right to enter into an executive session at any time during the meeting, in accordance with the Nebraska Open Meetings Act, even though the closed session may not be indicated on the agenda.

It is the intention of the City Council to take up the items on the agenda in sequential order. However, the City Council reserves the right to take up matters in a different order to accommodate the schedules of the City Council members, persons having items on the agenda, and the public.

13. Proclamations:

- **International Building Safety Month**
- **Peace Officers' Memorial Day and National Police Week**
- **Mental Health Month**

14. Police Chief Martinez - Recognition of the following officers:

- **Officer Geoffrey Willmann**
- **Officer Austin Kelley**
- **Officer Brandon Adams**

15. Ordinance No. 837 amendment to Section 31.22 of the City of Valley Municipal Code relating to the responsibilities of the Public Works Superintendent.

16. Public Works Superintendent consent to the appointment of the Public Works Superintendent.

17. Library consideration and approval of Interlocal Agreement with Douglas County, Nebraska/Douglas County Libraries and City of Valley. Resolution No. 2025-10.

18. Valley Police Department consideration and approval of Interlocal Agreement with Douglas Sarpy Mutual Aid. Resolution No. 2025-12

19. MAPA Safe Streets for All Memorandum of Understanding consideration and action to adopt the Metropolitan Area Planning Agency Memorandum of Understanding Comprehensive Safety Action Plan.

20. Human Resources Consultant consideration and action to retain a Human Resources Consultant.

21. Core & Main consideration and action to upgrade the meter reading program.

22. Shouses/Barndominiums consideration and approval to amend existing sections of the City of Valley Zoning regulations relating to shouses/barndominiums

- **Review**
- **Open Public Hearing**
- **Close Public Hearing**
- **Ordinance No. 836**

23. Annual Audit Report - review.

The City Council reserves the right to enter into an executive session at any time during the meeting, in accordance with the Nebraska Open Meetings Act, even though the closed session may not be indicated on the agenda.

It is the intention of the City Council to take up the items on the agenda in sequential order. However, the City Council reserves the right to take up matters in a different order to accommodate the schedules of the City Council members, persons having items on the agenda, and the public.

24. **Building and Zoning**

25. **City Administrator**

26. **PeopleService - update**

27. **City Engineer**

27.A. Water Treatment Plant Expansion - Eriksen Construction.

27.A.1. **Resolution No. 2025-13** consideration and action to approve Contractor's Application for Payment No. 4 in the amount of \$72,524.25 to Eriksen Construction.

27.B. Val-haven (Southwest No. 2) and Ginger Woods No. 2 Lift Station Improvements - Vrba Construction.

27.B.1. **Resolution No. 2025-14** consideration and action to approve Contractor's Application for Payment No. 3 in the amount of \$79,915.50 to Vrba Construction.

27.C. Ginger Cove Bridge Repainting - JEM Restoration Services, Inc.

27.C.1. **Resolution No. 2025-15** consideration and action to approve Contractor's Application for Payment No. 1 in the amount of \$101,242.00 to JEM Restoration Services, Inc.

27.D. FY 2025 Street Projects - Park and Platte

27.D.1. Consideration and action to waive Section 5.30 Minimum Design Standards for minimum pavement width.

27.D.2. Review of Bids.

27.D.3. Consideration and action to award construction contract.

27.D.4. Consideration and action to approve Change Order No. 1 from 2 The T Construction, LLC for an increase in the amount of \$33,600.00.

27.E. Swimming Pool Repairs

- Review of Bids.
- Consideration and action to award construction contract.

27.F. Water Main Replacement - Park and Platte

- Consideration and action to authorize advertisement for bids.

27.G. Other/Miscellaneous

- Valley Lakes Business Park - NL&L Concrete.

The City Council reserves the right to enter into an executive session at any time during the meeting, in accordance with the Nebraska Open Meetings Act, even though the closed session may not be indicated on the agenda.

It is the intention of the City Council to take up the items on the agenda in sequential order. However, the City Council reserves the right to take up matters in a different order to accommodate the schedules of the City Council members, persons having items on the agenda, and the public.

- Valley Landing - Sanitary Sewer, Water Main, and Storm Sewer improvements.

28. **City Attorney**

29. **Mayor's Report**

30. **Upcoming Items**

- Valley Days Planning Meeting: May 20, 2025 @ 6:00 p.m.
- Planning Commission: May 20, 2025 @ 4:30 p.m.
- The Effects of Social Media on Youth Mental Health: Risk Factors and Protective Measures. Open to the public. May 20, 2025, DC West High School Performing Arts Center. 7:00-8:00 p.m.
- Valley City clean-up May 31, 2025 9:00 a.m. - 2:00 p.m.

31. **Consideration of Proceeding in Close Session closed session is necessary for the protection of the public interest and pertains to threatened litigation and related matters.**

32. **Adjourn**

The City Council reserves the right to enter into an executive session at any time during the meeting, in accordance with the Nebraska Open Meetings Act, even though the closed session may not be indicated on the agenda.

It is the intention of the City Council to take up the items on the agenda in sequential order. However, the City Council reserves the right to take up matters in a different order to accommodate the schedules of the City Council members, persons having items on the agenda, and the public.

NOTICE OF MEETING

CITY OF VALLEY
Tuesday, May 13, 2025, at 7:00 P.M.
Valley City Hall
203 N. Spruce Street, Valley, NE

Notice is hereby given that a meeting of the City Council of the City of Valley, Nebraska will be held on **Tuesday, May 13, 2025, at 7:00 p.m.** at **Valley City Hall**.

Public Hearings will be held for the purpose of hearing testimony on the following:

- 1. Ordinance change to amend house/ barndominium rules, definition, and allowances in specific zoning districts.

An agenda kept continuously current shall be available for public inspection at Valley City Hall (203 N. Spruce Street).

Christie Donnermeyer, City Clerk

5/2 ZNEZ



Proof of Publication

JASON W. HUFF, Publisher

UNITED STATES OF AMERICA,
The State of Nebraska,
District of Nebraska,
County of Douglas,
City of Omaha } ss.

JASON W. HUFF, being duly sworn, deposes and say that they are the PUBLISHER and/or MANAGING EDITOR of THE DAILY RECORD, of Omaha, a legal newspaper, printed and published daily in the English language, having a bona fide paid circulation in Douglas County in excess of 300 copies, and a general circulation in Sarpy, Lancaster, Cass and Dodge Counties, printed in Omaha, in said County of Douglas, Nebraska for more than fifty-two weeks last past; that the printed notice here-to attached was published in THE DAILY RECORD, of Omaha, for 1 consecutive weeks on:

5/2/25

That said Newspaper during that time was regularly published and in general circulation in the County of Douglas, and State of Nebraska.

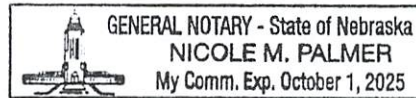

Publisher's Fee \$25.33

Additional Copies \$ _____

Subscribed in my presence and sworn to before me this MAY 02 2025

Filing Fee \$ _____

Total \$25.33

Notary Public in and for
Douglas County, State of Nebraska

MINUTES
REGULAR MEETING
April 8, 2025

1 and 2. Roll Call and Call to Order Mayor Grove called the meeting to order at 7:00 p.m. Present were Mayor Grove; Council Members, Batcher, L. Lewis, J. Lewis, and Hayden. Also present: City Attorney Jeff Farnham, City Administrator Cameron Gales, Clerk Christie Donnermeyer, Building Inspector Rune van den Boogaart, Treasurer Lori Sorensen, Utility Clerk Kindra Smith, and Library Director Sami Stewart.

Mayor Grove noted the location of the open meetings act, and stated one copy of all reproducible written material to be discussed at this meeting is available for examination or copying.

3. Pledge of Allegiance the Pledge of Allegiance was recited.

4. Proof of Publication the Proof of Publication was on the council desk.

5. Visitors/Correspondence

Jim Thiessen, Jr. 7506 N. 285th Cir expressed concerns regarding the delayed decision regarding repair of the pool.

Jeff Allen 623 N. Spruce St expressed concerns regarding the increased water and wastewater rates.

Kat Lydon 801 S. Valley View St expressed concerns regarding the increased water and wastewater rates and why the change to the allowances.

Brent Thiessen 400 S. Park Ave expressed concerns regarding the increased water and wastewater rates. He also stated that his water meter is not working and has not worked for the past 6 years. He would also like to know what is going on with Park Street.

6. Approval of Agenda Mayor Grove requested removal of item no. 15 Adoption of International Code from the agenda. Council member Batcher moved to approve the revised agenda. J. Lewis seconded. YES: Batcher, L. Lewis, J. Lewis, and Hayden. NO: no one. Motion carried.

7. Consent Agenda Council member Batcher moved to approve the consent agenda. J. Lewis seconded. YES: Batcher, L. Lewis, J. Lewis, and Hayden. NO: no one. Motion carried. Items on the consent agenda were March 11, 2025 Work Session, March 11 and March 24, Council minutes; Treasurer's Report, March Payroll \$102509.95 & IRA \$3473.34; Keno Receipts \$6814.27; PeopleService Report, Minutes and/or statistics of the following boards and/or committees: Jan. 9, 2025 Library minutes, March Library statistics, March 27, 2025 Cemetery Minutes, reappointments of Kyle Held to the Library Board and Larry Bottger to the Board of Adjustments and the following bills: **Services/Utilities/Insurance: Services/Utilities/Insurance:** Aflac 324.78; Amazon Business 536.56; Assoc for Rural & Small Libraries 75.00; Ben Tysor 301.00; Black Hills 1814.99; Cardinal HR 1625.00; Century Link 41.75; Cintas 284.88; Complete Tactical 2000.00; Creative Planning 2175.00; DataShield 149.28; Diamond Mowers 115.46; Douglas Cnty Environ 7492.00; Douglas Cnty Treas 2062.36; Eagle Engineering 38526.53; Eakes 248.97; Electric Pump

34846.75; EVO 4300.61; Farnham & Griffin 20889.77; FiveNines 8706.20; FP Finance Program 152.95; Granicus (SmartGov) 8483.18; Great Plains Comm 716.72; JEO Consult 5511.25; Matzen Cleaning 825.00; Mutual of Omaha 1606.61; Neb State Patrol 2990.63; Neb Sweeping 4614.82; OPPD 17529.03; PeopleService 34824.00; Retirement Plan 399.66; The Daily Record 577.98; Durham Museum 200.00; US Postal Service 350.00; Verizon 820.54; Waste Connections 345.90; Widhelm, J 1800.00; YMCA 50.00; Young's Service 188.00; **Supplies/Equipment:** Baker & Taylor 894.97; Bound to Stay Bound 235.68; Cappel Auto Supply 853.18; First Neb Credit Card 3529.30; Flat River Arms 4214.00; Fleet 155.55; FP Postage 500.00; Great Plains Uniforms 433.96; Host Coffee Service 29.96; JD Financial 2442.20; JP Cooke 40.01; Lakeshore 86.22; Love's 1165.44; Menards Elkhorn 51.78; Menards Fremont 238.33; Midwest Tape 443.14; NMC – Omaha HQ 209.63; Publication Printing 951.20; Rob's Oil 1135.67; **Bond/Loan/TIF Payments:** BOK Financial 34810.00; BOK Financial 28581.11; Bell Bank Equip Finance 22392.65; FNB/bond 5962.50; FNB/bond 5962.50; **Reimburse/Refund:** Dohrman K 35.76; Gales, C 210.14; Grove, C 200.00; Hrbek, Sr. T 78.50; Landmark Performance 1000.00; LIM Const 1150.00; Midwest Dwellings 1000.00; Sampson, G 106.75; Thompson & Sons 500.00.

8. **Jim Thiessen, Jr.**, addressed council with his concerns regarding advertising signs in city right-of-way and requested removal of same, except for non-profits. The Building Inspector addressed Mr. Thiessen's concerns with the current Ordinance governing such signage and asked council for direction on amending the Ordinance and policing signage of non-profits. Council member L. Lewis volunteered to be the contact person for clarification of whether an organization was a non-profit for signage purposes.

9. **Proclamations** Mayor Grove read the following Proclamations: National Library Week April 6-12; Arbor Day April 25; and Professional Municipal Clerks Week May 4-10.

10. **City Pool** City Administrator Gales addressed council with options regarding the needed repairs to the pool. Jerry Rinne addressed Council regarding lifeguard staffing issues. Greg Perry was asked to assist with evaluating with the repair determination. Much discussion was had regarding the current state of the pool, repairs versus rebuilding at the current location or a new location and the timeline of whether the pool would be open for the 2025 season. Council member L. Lewis moved to move forward with the procurement process for bids for repairs. Batcher seconded. YES: Batcher, L. Lewis, J. Lewis, and Hayden. NO: no one. Motion carried.

11. **DC West** Beth Royuk addressed council with DC West's Prom Committee's request for a donation. Council member L. Lewis moved to give the Committee a pool party at the Valley City Pool if the pool is open this year. J. Lewis seconded. YES: Batcher, L. Lewis, J. Lewis, and Hayden. NO: no one. Motion carried.

12. **OPPD** Chris Meeks, Government and Community Relations Strategist, Public Affairs addressed council with an update on two current projects Standing Bear and Turtle Creek. Chris also reviewed the March 19 blizzard damage.

13. **Resolution No. 2025-02** Conditional Use Permit for accessory building or accessory structure exception at 25050 Hwy 275. Building Inspector van den Boogaart addressed Council regarding the request and current condition of the accessory building. He also informed Council that Planning Commission had denied the request. Mayor Grove opened the public hearing. No one spoke. Mayor Grove closed the public hearing. Council member L. Lewis moved for passage of Resolution No. 2025-02 denying the conditional use permit. Hayden seconded. YES: Batcher, L. Lewis, J. Lewis, and Hayden. NO: no one. Motion Carried. A true, correct, and complete copy of said Resolution is on file at City Hall.

14. **Ordinance No. 836** amending existing sections of the City of Valley Zoning Regulations relating to shouses/barndominiums. Building Inspector Rune addressed council regarding the amendment. Mayor Grove opened the public hearing. Beth Royuk, 305 N. Pleasure Lake had a question regarding any space limitations. Mayor Grove closed the public hearing. Council member Batcher moved to table Ordinance No. 836 so the Building Inspector could do more research on increasing allowable percentage from garage to dwelling in transitional ag. L. Lewis seconded. YES: Batcher, L. Lewis, J. Lewis, and Hayden. NO: no one. Motion Carried.

15. **Adoption of International Code** this item was removed from the agenda.

16. **Resolution No. 2025-10** interlocal agreement between Dougals County Nebraska/Douglas County Libraries and City of Valley. City Attorney Farnham addressed council and stated that the Agreement needs further review and he would like to give the council more information on the agreement between the two entities. Council member L. Lewis moved to table Resolution No. 2025-10 to give the City Attorney more time for review and presentation to council. Batcher seconded. YES: Batcher, L. Lewis, J. Lewis, and Hayden. NO: no one. Motion Carried.

17. **Baird Holm** because of a potential violation of the Open Meetings Act concerning this agenda item, Mayor Grove turned the meeting over to Council President John Batcher and removed herself from the meeting. Council President Batcher upon advice of his attorney of the potential violation of the Open Meetings Act concerning this agenda item also removed himself from the meeting. After much discussion, council member L. Lewis moved to have the item removed from the agenda. There was no second. Council member J. Lewis moved to adjourn. L. Lewis seconded. YES: L. Lewis, J. Lewis, and Hayden. ABSENT: Batcher. NO: no one. Motion Carried. The meeting adjourned at 8:48 p.m.



Cindy Grove, Mayor



Christie Donnermeyer, City Clerk

**MINUTES
EMERGENCY MEETING
APRIL 15, 2025**

1 and 2. Roll Call and Call to Order Mayor Grove called the emergency meeting to order at 7:00 p.m. Present were Mayor Grove; Council Members, Batcher, L. Lewis, and J. Lewis and Hayden. Also present: City Attorneys Jeff Farnham and Andrea Griffin, City Administrator Cameron Gales, Clerk Christie Donnermeyer, Building Inspector Rune van den Boogaart, Treasurer Lori Sorensen, and Utility Clerk Kindra Smith.

The nature of the emergency meeting was to finish the business of the April 8, 2025 meeting wherein L. Lewis, J. Lewis, and Hayden adjourned the meeting before all the remaining items on the agenda were addressed and any necessary formal action taken. All formal action taken at the emergency meeting pertained only to the emergency.

Mayor Grove noted the location of the open meetings act, and stated one copy of all reproducible written material to be discussed at this meeting is available for examination or copying.

3. Pledge of Allegiance the Pledge of Allegiance was recited.

4. Proof of Publication the proof of posting the meeting in three different places was on the council table.

5. Visitors/Correspondence.

Wendy Deane, 207 N. Spruce Street. Ms. Deane addressed council regarding her concerns with the repairs to the city pool. She would like to see the city pool rebuilt at its current location.

Mary Ann Perkins 400 W Megis St. addressed council regarding issues with brown water and the need for Douglas County to flush the hydrants. She also requested that council work together and remember that they are working for the people.

6. Approval of Agenda Mayor Grove requested removal of item number 13. Council member Batcher moved to approve the revised agenda. J. Lewis seconded. YES: Batcher, L. Lewis, J. Lewis, and Hayden. NO: no one. Motion carried.

7. Treasurer Lori gave an update on the status of the audit. The audit has taken longer than expected primarily due to transitioning to GASB 34 accounting. Because the City was previously reporting on a cash basis, this transition represented a significant change to our financial reporting. Further difficulties were encountered with generating utility billing accounts receivable aging reports from the AccuFund system for reconciliation with the trial balance. To correct this issue and be able to tie back to the trial balance, manual spreadsheets were created which required further review and testing by the auditors to confirm accuracy. Another timeline issue was the Schedule of Expenditures of Federal Awards (SEFA) requirement for a single audit. Additional testing was needed to verify the outstanding grant receivable balances. Lori has been maintaining ongoing communications with the State Auditor's Office throughout the entire process. We are optimistic that the City of Valley will be able to submit the audit in May.

8. Building and Zoning Rune had nothing to report to Council.

9. Discussion Items City Attorney Griffin addressed council regarding past, present and future Tax Increment Financing (TIF) projects. She presented council with a spreadsheet showing the property valuations and timeline of the City's TIF projects. Attorney Jeff Farnham addressed council with his recommendation to amend the City's 2018 Comprehensive Development Plan (CDP). He recommended amending the CDP which is over five years old, regarding its stance on Sanitary Improvement Districts (SID). He will be consulting with JEO on the amendments and presenting those amendments to Planning Commission as well as City Council.

10. City Administrator Cameron addressed council with updates on the following: Park project. The concrete needs a surface temperature of 50 degrees to meet the manufacturer's warranty requirements for the acrylic court surfacing. We are in the final stages of grading, joint sealants, landscaping, sprinkler installation, and seeding/sod. Human Resources. Interviewing for a Deputy Clerk and Public Works Director. Also, in the review stage of proposals for an HR Consultant. We do not anticipate the final negotiated cost will be more than the \$29,999 for their assistance with staffing, employee management, employee handbook as well as staffing issues and grievance procedures. Core and Main. Propagation is complete. One antenna is needed and will support the growth of 25,000 more utility customers. The next steps will be council approval of the project. Water Tower. Subcontractor Onyx is out of business. The bonding company for Onyx is in the process of finding and retaining a new contractor to complete the work at no expense to the City.

11. City Engineer Greg Perry was not able to attend. The Building Inspector van den Boogaart gave the City Engineer's report as follows:

Council member Batcher moved for passage of Resolution No. 2025-11 approving contractor's application for payment no. 3 in the amount of \$292,801.50 from Eriksen Construction for the water treatment plant expansion. J. Lewis seconded. YES: Batcher, L. Lewis, J. Lewis and Hayden. NO: no one. Motion carried. A true, correct, and complete copy of said Resolution is on file at City Hall.

Council member Batcher moved for approval of change order no. 1 for an adjustment to the contract time for coordination with final plat and Developer's escrow agreement from NL&L Concrete, Inc. for the Valley Lakes Business Park Sanitary Sewer and Water Main improvements. J. Lewis seconded. YES: Batcher, L. Lewis, J. Lewis and Hayden. NO: no one, motion carried.

Val-haven and Ginger Woods lift stations, Vrba construction is working on Val-haven this week and is scheduled to complete the work this week and complete the work at Ginger Cove next week to wrap up the project. Ginger Cove Bridge repainting contractor has mobilized equipment at the bridge and the project is anticipated to last 5-6 weeks. Valley Landing sanitary sewer, water main, and storm sewer the contractor mobilized equipment last week and installation is anticipated to start by next week.

Council member Batcher moved to approve advertising for bids for the FY2025 street projects. L. Lewis seconded. YES: Batcher, L. Lewis, J. Lewis, and Hayden. NO: no one. Motion Carried.

12. **City Attorney** Jeff Farnham gave updates on Glass Lake, need for a TIF committee meeting, working on the Library interlocal agreement, and personnel matters.

13. **Consideration of proceeding in close session.** This item was removed from the agenda.

14. **Mayor's Report** Mayor Grove gave her annual report of the City which consisted of population data, city data, residential development, commercial development and city projects.

15. **Upcoming Items** Planning Commission April 15, 2025 at 4:30 p.m.; Valley Days Planning meeting April 15, 2025 at 6:00 p.m.; Arbor Day Celebration April 25, 2025; City-wide clean-up May 31, 2025 9:00 a.m. to 2:00 p.m.

16. **Adjourn** Council Member L. Lewis moved to adjourn. J. Lewis seconded. YES: Batchner, L. Lewis, J. Lewis, and Hayden. NO: no one. Motion carried. Meeting adjourned at 7:43 p.m.



Cindy Grove, Mayor



Christie Donnermeyer, City Clerk

Treasurer's Report April 2025							
		Cash Balance 3/31/2025	Net Income or (Loss)	Inter-fund Transfers	Cash Balance 4/30/2025	Investments 4/30/2025	Outstanding Checks
						\$14,554.22	(\$55,346.58)
General - Fund 1		\$494,702.49	\$490,922.67	\$279,022.57	\$1,264,647.73		
General MM		\$1,424,160.39	\$603.65	(\$17,633.10)	\$1,407,130.94		
Pines Assessments		\$304,600.36	\$694.31	\$2,580.08	\$307,874.75		
Bond - Fund 2	021	\$461,362.56	\$73,918.79	(\$147,212.17)	\$388,069.18		
C D A	001	\$1,000.00			\$1,000.00		
		\$2,685,825.80	\$566,139.42	\$116,757.38	\$3,368,722.60		
City of Valley Pooled Cash Proprietary Funds							
		Cash Balance 3/31/2025	Net Income or (Loss)	Inter-fund Transfers	Cash Balance 4/30/2025	Investments 4/30/2025	
Funds						\$9,929.07	
Water/Waste - Fund	024	\$2,163,343.35	\$414,726.69	(\$280,299.13)	\$2,297,770.91		
Cap. Facility Chg.	024	\$2,137,322.96	\$5,199.34	\$182,473.20	\$2,324,995.50		
		\$4,300,666.31	\$419,926.03	(\$97,825.93)	\$4,622,766.41		
		Cash Balance 3/31/2025	Net Income or (Loss)	Inter-fund Transfers	Cash Balance 4/30/2025		
Fund 4							
Nursing Home	050	\$1,075,401.54	\$25,792.03	(\$11,925.00)	\$1,089,268.57		
Fund 8							
Keno	056	\$384,779.33	\$7,891.98		\$392,671.31		
Fund 10							
Sales Tax	058	\$6,200,453.10	\$143,935.11		\$6,344,388.21		
ARPA		\$169,839.11	\$341.66	(\$7,006.45)	\$163,174.32		
		\$7,830,473.08	\$177,960.78	(\$18,931.45)	\$7,989,502.41		
Total All Funds		\$14,816,965.19	\$1,164,026.23	\$0.00	\$15,980,991.42	\$24,483.29	

City of Valley
Accounts Payable Status with Accounting Distribution by Vendor

				<u>Amount</u>
[103] ACCUFUND				
	4/02/2025	5/14/2025	5/14/2025 PHONE CALLS/EMAILS RATE INCREASE/CONSUMPTION CHANGE	1,700.00
Total for[103] ACCUFUND				1,700.00
[3235] Adams, Brandon James				
	5/06/2025	5/14/2025	5/14/2025 MILEAGE - PERSONAL CAR FOR TRAINING	136.08
Total for[3235] Adams, Brandon James				136.08
[232] ADVANCED HEATING & A/C				
	1/10/2025	5/14/2025	5/14/2025 WATER TREATMENT PLANT SERVICE CALL INSTALLATION OF NON- PROGRAMMABLE THERMOSTAT	350.00
Total for[232] ADVANCED HEATING & A/C				350.00
[1932] AFLAC				
	4/12/2025	5/14/2025	5/14/2025 APRIL BILLING PERIOD	251.22
Total for[1932] AFLAC				251.22
[035184] Amazon Business				
	4/15/2025	5/14/2025	5/14/2025 SIT/STAND DESK FOR CAMERON GALES	429.00
	4/15/2025	5/14/2025	5/14/2025 POS SYSTEM CASH REGISTER DRAWER	59.35
	4/14/2025	5/14/2025	5/14/2025 DOGIPOT TRASH LINERS CASE OF 50 X2 DOGIPOT PICK UP BAG ROLLS 200 PER ROLL/PACK OF 10	144.90
	5/05/2025	5/14/2025	5/14/2025 ADJUSTABLE VERTICLE LAPTOP STAND DUAL MONITOR RISER	72.49
	3/27/2025	5/14/2025	5/14/2025 NEXIGO N60 1080P WEBCAM W/MICROPHONE	21.93
	5/05/2025	5/14/2025	5/14/2025 BEYOND THE VEIL	14.99

5/02/2025	5/14/2025	5/14/2025	SIT/STAND DESK FOR LORI	339.15
4/16/2025	5/14/2025	5/14/2025	LEATHER DESK PAD BLOTTER/MOUSE PAD	35.03
Total for[035184] Amazon Business				1,116.84
[525] AMERICAN LEGAL PUBLISHING				
4/14/2025	5/14/2025	5/14/2025	INTERNET RENEWAL ZONING/SUBDIVISION 05/02/2025 - 05/02/2026	250.00
4/23/2025	5/14/2025	5/14/2025	2025 S-2 SUPPLEMENT PAGES (ZONING/SUBD)	260.00
4/29/2025	5/14/2025	5/14/2025	APRIL 2025 S-1 EDITING CODE	380.00
Total for[525] AMERICAN LEGAL PUBLISHING				890.00
[16716] ART OF A CRAFTSMAN				
4/25/2025	5/14/2025	5/14/2025	PERMIT BUILDING REFUND AT 28551 JESSIE CR	1,000.00
Total for[16716] ART OF A CRAFTSMAN				1,000.00
[277930] Baker & Taylor				
4/21/2025	5/14/2025	5/14/2025	BOOKS X16	293.60
4/30/2025	5/14/2025	5/14/2025	BOOKS X74	473.98
Total for[277930] Baker & Taylor				767.58
[248] Bauer Built				
4/29/2025	5/14/2025	5/14/2025	MULTITRAC TIRES X2 - TURF TIRES	272.00
Total for[248] Bauer Built				272.00
[7950] Bizco Tech				
4/28/2025	5/14/2025	5/14/2025	2 CRUISERS CITATION COMPUTER UPGRADES	9,428.00
Total for[7950] Bizco Tech				9,428.00
[7966] Black Hills Energy				

4/24/2025	5/14/2025	5/14/2025	NATURAL GAS ALL DEPARTMENTS	855.95
			PERIOD: 03/25/2025 - 04/23/2025	

Total for[7966] Black Hills Energy				855.95
---	--	--	--	---------------

[1000201] BLAND & ASSOCIATES

4/30/2025	5/14/2025	5/14/2025	CHANGE ORDER FOR INCORRECT SEFA DUPLICATED WORK TRIAL BALANCE ISSUES	5,000.00
-----------	-----------	-----------	--	----------

Total for[1000201] BLAND & ASSOCIATES				5,000.00
--	--	--	--	-----------------

[1203] CAPPEL AUTO SUPPLY

4/17/2025	5/14/2025	5/14/2025	NBH HYBRID AIR HOSE	55.99
-----------	-----------	-----------	---------------------	-------

Total for[1203] CAPPEL AUTO SUPPLY				55.99
---	--	--	--	--------------

[2961] CENTURYLINK

4/24/2025	5/14/2025	5/14/2025	POOL PHONE - VACATION MODE SERVICE- 04/24/2025 - 05/23/2025	41.78
-----------	-----------	-----------	---	-------

Total for[2961] CENTURYLINK				41.78
------------------------------------	--	--	--	--------------

[631025] CINTAS CORP

4/17/2025	5/14/2025	5/14/2025	CINTAS - CITY OF VALLEY INVOICE: 4226211953 \$98.73 AIR SVC, SOAP, 3X5, 4X6, 4X6 LOGO 4227709819 \$52.18 3X5 -1, 4X6 - 4, 4X6 LOGO -2 4229185605 \$105.78 AIR SVC, SOAP, 3X5, 4X6, 4X6 LOGO	256.69
-----------	-----------	-----------	--	--------

4/14/2025	5/14/2025	5/14/2025	SHOP/POLICE/OFFICE FIRST AID CABINET	184.51
-----------	-----------	-----------	---	--------

4/17/2025	5/14/2025	5/14/2025	CINTAS - VALLEY PUBLIC LIBRARY INVOICES: 4227709740 \$18.33 3X10, 4X6 4226211938 \$86.80 TP RFL, AIR SVC, SOAP, PAPER TWL, 3X10, 4X6 4229185652 \$56.41 TP RFL, AIR SVC, SOAP, PAPER TWL, 3X10, 4X6	161.54
Total for[631025] CINTAS CORP				602.74
[2010152] CLARK, THOMAS & KRISTINE				
4/18/2025	5/14/2025	5/14/2025	REQUESTED CREDIT BE REFUNDED	154.05
Total for[2010152] CLARK, THOMAS & KRISTINE				154.05
[28330] CORE & MAIN				
4/07/2025	5/14/2025	5/14/2025	510M S/POINT M2 TC SP HR & LD X108	20,520.00
4/28/2025	5/14/2025	5/14/2025	TOUCHPAD BLACK X100	810.00
4/28/2025	5/14/2025	5/14/2025	3/4 METER X32 3WIRE W/25' CABLE	5,430.40
Total for[28330] CORE & MAIN				26,760.40
[4502] Cornhusker International Trucks Inc				
3/18/2025	5/14/2025	5/14/2025	2024 INTERNATIONAL PARTS AND LABOR	1,382.81
Total for[4502] Cornhusker International Trucks Inc				1,382.81
[1000156] CREATIVE PLANNING				
4/30/2025	5/14/2025	5/14/2025	APRIL PROGRESS BILL \$1075 PROGRESS BILL AUDIT REPORT PREP \$10,000	11,075.00
Total for[1000156] CREATIVE PLANNING				11,075.00
[8458] DATASHIELD CORPORATION				
5/01/2025	5/14/2025	5/14/2025	CITY HALL ONSITE DESTRUCTION	49.64
5/01/2025	5/14/2025	5/14/2025	POLICE ONSITE DESTRUCTION	50.00
Total for[8458] DATASHIELD CORPORATION				99.64
[378] DC WEST SCHOOL DISTRICT #15				

4/28/2025	5/14/2025	5/14/2025	AUDITORIUM PAC CENTER MENTAL HEALTH AWARENESS TRAINING 05/20/2025	75.00
Total for[378] DC WEST SCHOOL DISTRICT #15				75.00
[15335] DOUGLAS COUNTY ENVIRONMENTAL SERVICES				
5/05/2025	5/14/2025	5/14/2025	APRIL 2025 ELECTRICAL INSPECTION 45 - \$3150 ELECTRICAL PLAN REVIEW 12-\$624 BUILDING INSPECTION 11 - \$770	4,544.00
Total for[15335] DOUGLAS COUNTY ENVIRONMENTAL SERVICES				4,544.00
[231] EAGLE EYE ENTERPRISES				
4/25/2025	5/14/2025	5/14/2025	BUILDING PERMIT REFUND AT 6618 N 289	500.00
Total for[231] EAGLE EYE ENTERPRISES				500.00
[11190] Eakes Office Solutions				
4/15/2025	5/14/2025	5/14/2025	LIBRARY KLEENEX	62.97
4/15/2025	5/14/2025	5/14/2025	COPY PAPER #20	47.10
5/01/2025	5/14/2025	5/14/2025	POLICE/CITY HALL LEGAL PAD X12 PAPER #20 X3	157.50
4/25/2025	5/14/2025	5/14/2025	POLICE CONTRACT BILLING CHARGE FOR 01/25/2025 - 04/24/2025 BILLING	224.17
5/01/2025	5/14/2025	5/14/2025	LIBRARY CONTRACT BILLING CHARGE 02/01/2025 - 04/30/2025 RIC/IMC2500	157.36
5/07/2025	5/14/2025	5/14/2025	CITY HALL 02/07/2025 - 05/06/2025 SHR/BP70C31	275.26
Total for[11190] Eakes Office Solutions				924.36
[6043900] ECHELON HOMES LLC				
5/05/2025	5/14/2025	5/14/2025	Water Deposit Refund from 2020 - 6407 N 295 ST Replaces check# 50852 - 06/2020	150.00

Total for[6043900] ECHELON HOMES LLC				150.00
[4280] ELECTRIC PUMP				
4/08/2025	5/14/2025	5/14/2025	LS1/LS2 PRESSURE TEST TROUBLESHOOT/REPAIR PUMP @ MEIGS LS	3,961.25
Total for[4280] ELECTRIC PUMP				3,961.25
[207702] EVERETT'S AUTO REPAIR				
2/14/2025	5/14/2025	5/14/2025	JD GATOR POWER STEERING FUSE REPLACED	259.50
4/22/2025	5/14/2025	5/14/2025	2016 FORD INTERCEPTOR REPLACED OG SENSOR	319.77
4/28/2025	5/14/2025	5/14/2025	TIRE REPAIR - JD1575	35.00
Total for[207702] EVERETT'S AUTO REPAIR				614.27
[6047800] FALCONE HOMES				
4/25/2025	5/14/2025	5/14/2025	BUILDING PERMIT REFUND AT 6105 N 292 CR	1,000.00
4/25/2025	5/14/2025	5/14/2025	WATER DEPOSIT REFUND AT 6105 N 292 CR	150.00
Total for[6047800] FALCONE HOMES				1,150.00
[220] FARNHAM & GRIFFIN, P.C., L.L.O.				
4/30/2025	5/14/2025	5/14/2025	LEGAL COSTS 04/01/2025 - 04/30/2025 FLATWATE ESTATES CLAIM GENERAL GLASS LAKE SNIDE APPEAL	11,327.50
Total for[220] FARNHAM & GRIFFIN, P.C., L.L.O.				11,327.50
[186] First Nebraska Bank (Brainard)				
5/01/2025	5/14/2025	5/14/2025	NURSING HOME BOND PAYMENT #130 MAY 2025 INTEREST \$2534.58 PRINCIPAL \$3427.92	5,962.50
Total for[186] First Nebraska Bank (Brainard)				5,962.50
[2020002] FIRST NEBRASKA BANK (CREDIT CARD)				

4/02/2025	5/14/2025	5/14/2025	4" TERRACOTTA CLAY POT X25	39.50
4/01/2025	5/14/2025	5/14/2025	BRIGHT COPY PAYER 150SHEETS PLASTIC TABLE COVERS X2 2" TERRACOTTA CLAY POT X30	37.92
4/11/2025	5/14/2025	5/14/2025	LIBRARY MAIL FLAGS2024 STAMPS X100	77.40
4/28/2025	5/14/2025	5/14/2025	E-CITATION PROJECT BROTHER POCKETJET PAPER ROLLS 36 ROLLS X2	479.90
4/28/2025	5/14/2025	5/14/2025	E-CITATION PROJECT PJ883	674.10
4/25/2025	5/14/2025	5/14/2025	SAFELITE REPAIR 2019 DODGE CHARGER	173.54
4/03/2025	5/14/2025	5/14/2025	METRO TESTING CENTER DMIN CHARGE	30.00
4/08/2025	5/14/2025	5/14/2025	PAID SHORTED POSTAGE	0.73
3/31/2025	5/14/2025	5/14/2025	BULK MAILLING, SHORT POSTAGE, PERMIT FEE	561.64
4/03/2025	5/14/2025	5/14/2025	TWILIO SENDGRID COMPUTER SOFTWARE	19.95
4/08/2025	5/14/2025	5/14/2025	WATER FOR COUNCIL CHAMBERS	5.79
4/24/2025	5/14/2025	5/14/2025	OFFICE DEPOT DUAL MONITOR	78.10
4/16/2025	5/14/2025	5/14/2025	BHM WORLD HERALD NEWSPAPER	34.99
4/25/2025	5/14/2025	5/14/2025	FINAL INVOICE WESTLAW PROFLEX MULTI LOC AGREEMENT	199.26

Total for[2020002] FIRST NEBRASKA BANK (CREDIT CARD)				2,412.82
---	--	--	--	-----------------

[203] FIRST STATE NEBRASKA BANK

5/01/2025	5/14/2025	5/14/2025	NURSING HOME BOND PAYMENT #130 MAY 2025 INTEREST \$2534.58 PRINCIPAL \$3427.92	5,962.50
-----------	-----------	-----------	--	----------

Total for[203] FIRST STATE NEBRASKA BANK				5,962.50
---	--	--	--	-----------------

[619] FIVE NINES TECHNOLOGY GROUP INC

5/01/2025	5/14/2025	5/14/2025	MAY INVOICE ALL DEPTS	5,317.90
-----------	-----------	-----------	-----------------------	----------

Total for[619] FIVE NINES TECHNOLOGY GROUP INC				5,317.90
---	--	--	--	-----------------

[1000196] FP FINANCE PROGRAM

5/05/2025	5/14/2025	5/14/2025	STANDARD PAYMENT	152.95
-----------	-----------	-----------	------------------	--------

Total for[1000196] FP FINANCE PROGRAM				152.95
--	--	--	--	---------------

[635] Fremont Department of Utilities

4/05/2025	5/14/2025	5/14/2025	MONTHLY SEWER CHARGE TEST - 03/05/2025 BOD 163/SOLIDS 138 03/28/2025 - 38,4000,148 02/28/2025 - 25,577,532 CONSUMPTION 12,822,616 GALLONS; 17,141 CCF	53,363.38
-----------	-----------	-----------	---	-----------

Total for[635] Fremont Department of Utilities				53,363.38
---	--	--	--	------------------

[2324] Fremont Winnelson

4/29/2025	5/14/2025	5/14/2025	VB REPAIR KIT X2 H553 O-RING X24 A156A DIAPHRAGM X2 SCREW STOP LESS CAP X1	151.35
-----------	-----------	-----------	---	--------

Total for[2324] Fremont Winnelson				151.35
--	--	--	--	---------------

[6064800] FRONTIER BUILDERS LLC

4/21/2025	5/14/2025	5/14/2025	BUILDING REFUND PERMIT 29215 MARTIN CR	1,000.00
4/21/2025	5/14/2025	5/14/2025	WATER DEPOSIT REFUND 29215 MARTIN CR	150.00

Total for[6064800] FRONTIER BUILDERS LLC				1,150.00
---	--	--	--	-----------------

[6061500] G LEE HOMES

4/25/2025	5/14/2025	5/14/2025	BUILDING DEPOSIT REFUND AT 6206 N 293 CR	1,000.00
-----------	-----------	-----------	---	----------

4/25/2025	5/14/2025	5/14/2025	WATER DEPOSIT REFUND AT 6206 N 293 CR	150.00
-----------	-----------	-----------	--	--------

Total for[6061500] G LEE HOMES				1,150.00
---------------------------------------	--	--	--	-----------------

[2058] GREAT PLAINS COMMUNICATIONS

3/01/2025	5/14/2025	5/14/2025	WATER TREATMENT PLANT MARCH 2025	156.74
-----------	-----------	-----------	-------------------------------------	--------

5/01/2025	5/14/2025	5/14/2025	WATER TREATMENT PLANT APRIL/MAY 2025	177.28
-----------	-----------	-----------	---	--------

5/01/2025	5/14/2025	5/14/2025	GENERAL/POLICE/STREETS/WATER MAY 2025 TELEPHONE/INTERNET	687.17
-----------	-----------	-----------	---	--------

5/01/2025	5/14/2025	5/14/2025	LIBRARY MAY 2025 INTERNET/TELEPHONE	376.48
-----------	-----------	-----------	--	--------

Total for[2058] GREAT PLAINS COMMUNICATIONS				1,397.67
--	--	--	--	-----------------

[4308] GREAT PLAINS UNIFORMS

4/24/2025	5/14/2025	5/14/2025	CALEB CLARK GHA-EXTERNAL BLACK CARRIERS SLM=XA PRO 3D V9 GT	669.50
-----------	-----------	-----------	---	--------

4/21/2025	5/14/2025	5/14/2025	BRANDON ADAMS FT-114038-19-36 34 BLACK A2 PANT PRP-F5341 BLACK M ICE PERFORAMCE POLO GPU-SEW2 SEW ON PATCH BLACK CLIP ON TIE	152.98
-----------	-----------	-----------	--	--------

5/01/2025	5/14/2025	5/14/2025	BRANDON ADAMS DARK NAVY LONG SLEEVE GPU-SEW2 SEW ON PATCHES X2 DARK NAVY NON CARGO TROUSER	147.72
-----------	-----------	-----------	---	--------

Total for[4308] GREAT PLAINS UNIFORMS				970.20
--	--	--	--	---------------

[0323] Helena Agri-Ent LLC

3/13/2025	5/14/2025	5/14/2025	PRMATE866 X3 PREMIUM002 X2.5 HEL-FIRE X5 ROUNDUP X7 MILESTO1 X1 HARDBALL X5 PRMATE299 X41	1,800.39
-----------	-----------	-----------	---	----------

Total for[0323] Helena Agri-Ent LLC **1,800.39**

[9444] Host Coffee Service

4/09/2025	5/14/2025	5/14/2025	SUGAR CANISTER X2 CREAMER CANISTER X2	11.56
4/14/2025	5/14/2025	5/14/2025	5 GALLON RO WATER	5.00
4/15/2025	5/14/2025	5/14/2025	10" INLINE WATER FILTER REPLACEMENT	56.92
4/30/2025	5/14/2025	5/14/2025	WATER COOLER	29.96
5/07/2025	5/14/2025	5/14/2025	LIPTON CHICKEN SOUP COLUMBIAN COFFEE X2	94.51

Total for[9444] Host Coffee Service **197.95**

[1000385] Hunt Home Remodeling

4/25/2025	5/14/2025	5/14/2025	BUILDING PERMIT REFUND AT 97 GINGER COVE RD	500.00
-----------	-----------	-----------	--	--------

Total for[1000385] Hunt Home Remodeling **500.00**

[1730] J Nielsen Construction LLC

4/21/2025	5/14/2025	5/14/2025	BUILDING PERMIT REFUND 29015 MARY ST	1,000.00
4/21/2025	5/14/2025	5/14/2025	WATER DEPOSIT REFUND 29015 MARY ST	150.00

Total for[1730] J Nielsen Construction LLC **1,150.00**

[2176400] JD'S CAR WASH & DETAILING LLC

4/30/2025	5/14/2025	5/14/2025	APRIL CAR WASHES	124.95
-----------	-----------	-----------	------------------	--------

Total for[2176400] JD'S CAR WASH & DETAILING LLC					124.95
[1000246] LAKESHORE					
	3/12/2025	5/14/2025	5/14/2025	FUNDED BY ALA GRANT AWAREDED FY24 DLB SIDED W-W MAG ROOM DIVIDER FLEX-SPACE WOBBLER CUSHION WOBBLER CUSHION TABLETOP LIGHT	860.14
Total for[1000246] LAKESHORE					860.14
[1201] LANOHA					
	4/30/2025	5/14/2025	5/14/2025	LILAC IVORY SILK 7G LILAC IVORY SILK #10 LOCUST STREET KEEPER #7 BLACK GUM WILDFIRE X2	989.95
Total for[1201] LANOHA					989.95
[7034500] LIM CONSTRUCTION DBA EVOLVED STRUCTURES					
	4/25/2025	5/14/2025	5/14/2025	BUILDING PERMIT REFUND AT 28480 LAUREL CR	1,000.00
Total for[7034500] LIM CONSTRUCTION DBA EVOLVED STRUCTURES					1,000.00
[842568] LOVE'S TRAVEL STOPS & COUNTRY STORE					
	3/31/2025	5/14/2025	5/14/2025	LOVE'S ACCT.# 3548803. POLICE/PUBLIC WORKS/BUILDING INSPECTOR/MAYOR-ADMIN INVOICES: 6013565717, 6013635204, 6013707437, 6013777666, 6013847611 03/24/2025 - 04/27/2025	914.24
	4/07/2025	5/14/2025	5/14/2025	LOVE'S ACCT.# 3573399. POLICE INVOICES: 6013635294, 6013707249, 6013775115, 6013847547, 6013919945 03/31/2025 - 05/04/2025	1,008.65
Total for[842568] LOVE'S TRAVEL STOPS & COUNTRY STORE					1,922.89
[4140] Meco-Henne Contracting Inc					
	4/11/2025	5/14/2025	5/14/2025	APPLICATION #5	239,382.00
Total for[4140] Meco-Henne Contracting Inc					239,382.00
[1000406] MEDI-WASTE DISPOSAL, LLC					

4/30/2025	5/14/2025	5/14/2025	45LB BOX - DNA EVIDENCE DESTROYED 04/02/2025	150.00
-----------	-----------	-----------	--	--------

Total for[1000406] MEDI-WASTE DISPOSAL, LLC				150.00
--	--	--	--	---------------

[1317] Menards- Fremont

4/09/2025	5/14/2025	5/14/2025	WEDGE ANCHOR 3/8X3 1/8"x50' WIRE ROPE/CABLE 1/8" WIRE SPLICE SLEEVE 5/32" WIRE SPLICE SLEEVE SDS+DRILLBIT 3/8"x6" 24" FOLDING SWAGING TOOL 3/32" WIRE SPLICE SLEEVE	135.58
-----------	-----------	-----------	---	--------

4/29/2025	5/14/2025	5/14/2025	2-1/2" DIAMOND BLADE DEBURRING REPL BLADES DEBURRING TOOL LENOX TUB CUTTER 1/8" - 1-1/8" PIPE CUTTER 3/4" PIPE FITTING BRUSH 1/2" PIPE FITTING BRUSH	59.66
-----------	-----------	-----------	--	-------

4/29/2025	5/14/2025	5/14/2025	42G 20CT CONTRACTOR BAGS - PARKS 5000ALO 3CCT STRIP - POLICE	133.91
-----------	-----------	-----------	--	--------

Total for[1317] Menards- Fremont				329.15
---	--	--	--	---------------

[1313] Michael Matzen

5/05/2025	5/14/2025	5/14/2025	CITY HALL/LIBRARY APRIL 2025	825.00
-----------	-----------	-----------	---------------------------------	--------

Total for[1313] Michael Matzen				825.00
---------------------------------------	--	--	--	---------------

[1328] Michael Todd Industrial Supply

5/07/2025	5/14/2025	5/14/2025	285TH STREET SIGN LAUREL ST SIGN 2581ST AVE STREET SIGN	94.99
-----------	-----------	-----------	---	-------

Total for[1328] Michael Todd Industrial Supply				94.99
---	--	--	--	--------------

[1331] Midwest Alarm Fire & Security Systems

4/03/2025	5/14/2025	5/14/2025	ANNUAL MONITORING SERVICE	1,947.78
-----------	-----------	-----------	---------------------------	----------

4/30/2025	5/14/2025	5/14/2025	SECURITY INSTALLATION PUBLIC WORKS	10,502.79
4/30/2025	5/14/2025	5/14/2025	FIXED LOOSE DOOR STRIKE IN BROKN DOOR JAM	298.75
Total for[1331] Midwest Alarm Fire & Security Systems				12,749.32
[715733] Midwest Tape LLC				
4/04/2025	5/14/2025	5/14/2025	DVD: SONIC THE HEDGEHOG 3	25.49
Total for[715733] Midwest Tape LLC				25.49
[1379] Murphy Tractor & Equipment				
5/06/2025	5/14/2025	5/14/2025	DIAMOND MOWER SWING MOTOR REPLACEMENT	2,005.12
Total for[1379] Murphy Tractor & Equipment				2,005.12
[2147] MUTUAL OF OMAHA PAYMENT PROCESSING CENTER				
5/01/2025	5/14/2025	5/14/2025	EMPLOYEE INSURANCE COVERAGE MAY 2025	1,463.91
Total for[2147] MUTUAL OF OMAHA PAYMENT PROCESSING CENTER				1,463.91
[1457] Nebraska Sweeping Inc				
5/08/2025	5/14/2025	5/14/2205	STREET SWEEPING 05/01/2025, 05/02/2025, 05/05/2025 - 05/08/2025 RESIDENTIAL 136X - \$2703.68 WIDE STREETS 13X - \$404.04 FLAT WATER 2.5X - \$500.00 10% FUEL SURCHARGE - \$360.77	3,968.49
Total for[1457] Nebraska Sweeping Inc				3,968.49
[1512] Omaha Door & Window Co. Inc.				
4/26/2025	5/14/2025	5/14/2025	NEW DOOR BUILDING INSPECTOR	914.75
Total for[1512] Omaha Door & Window Co. Inc.				914.75
[3065] OPPD				
4/08/2025	5/14/2025	5/14/2025	XMAS LIGHTS NO BILLING PERIOD LISTED	391.21
4/11/2025	5/14/2025	5/14/2025	ALL DEPARTMENTS 03/10/2025 - 04/08/2025	17,055.80
Total for[3065] OPPD				17,447.01
[1000231] PAVERS INC.				

5/05/2025	5/14/2025	5/14/2025	COLD MIX ASPHALT 1.71 TONS	285.57
Total for[1000231] PAVERS INC.				285.57
[1617] PEOPLESERVICE INC				
4/15/2025	5/14/2025	5/14/2025	MAY MONTHLY SERVICE	34,824.00
Total for[1617] PEOPLESERVICE INC				34,824.00
[1000330] Prairie Construction Co				
4/21/2025	5/14/2025	5/14/2025	BUILDING PERMIT REFUND 7330 N WEST	1,000.00
Total for[1000330] Prairie Construction Co				1,000.00
[208] Publication Printing				
4/09/2025	5/14/2025	5/14/2025	ABANDONED VEHICLE NOTICE	148.40
Total for[208] Publication Printing				148.40
[314] ROB'S OIL COMPANY INC				
3/26/2025	5/14/2025	5/14/2025	365.8 GALLONS CLEAR DIESEL	1,441.77
Total for[314] ROB'S OIL COMPANY INC				1,441.77
[1000195] Stanzel's Mow & Snow, LLC				
4/09/2025	5/14/2025	5/14/2025	128 GINGER COVE SAND REMOVAL NEW SOD COVER HOLES WITH TOP SOIL	795.00
Total for[1000195] Stanzel's Mow & Snow, LLC				795.00
[2019902] THE DAILY RECORD				
4/23/2025	5/14/2025	5/14/2025	PARK AVE & PLATTE ST PAVING IMPROVEMENTS	186.77
4/23/2025	5/14/2025	5/14/2025	SWIMMING POOL REPAIRS	183.12
4/15/2025	5/14/2025	5/14/2025	NOTICE OF MEETING MINUTES	54.00
4/08/2025	5/14/2025	5/14/2025	NOTICE OF MEETING MINUTES	77.33
5/02/2025	5/14/2025	5/14/2025	NOTICE OF MEETING CITY COUNCIL ORDINANCE CHANGE	25.33
Total for[2019902] THE DAILY RECORD				526.55
[5095] TRADE WELL PALLET INC				
4/01/2025	5/14/2025	5/14/2025	CERTIFIED WOODCHIPS X2	180.00

Total for[5095] TRADE WELL PALLET INC **180.00**

[1000405] TREETOP PRODUCTS LLC

3/31/2025	5/14/2025	5/14/2025	6' WALK-THRU TABLE X12	33,849.92
			6' METAL BENCH X10	
			8' WALK THRU PICNIC TABLE; ADA	
			1 CHAIR X4	
			32 GALLON FAIRFIELD RECEPTACLE	
			X20	
			SURFACE MOUNT HARDWARE KIT	
			X10	

Total for[1000405] TREETOP PRODUCTS LLC **33,849.92**

[1000121] ULINE

4/23/2025	5/14/2025	5/14/2025	PARTIALLY FUNDED BY NLC	1,500.43
			IMPROVEMENT GRANT	
			72X78" METRO LDESK WALNUT	
			MOBILE PEDESTAL FILE	
			ULTIMATE TOTE	

Total for[1000121] ULINE **1,500.43**

[7304] VALLEY ACE HARDWARE

3/05/2025	5/14/2025	5/14/2025	POLICE DEPT	41.99
			HALF FACE RESP P100	
3/03/2025	5/14/2025	5/14/2025	PUBLIC WORKS SHOP	24.36
			BLK&GLD DRILL BIT 1/4"	
			ALUMINUM ROD 0.25X48"	
3/04/2025	5/14/2025	5/14/2025	PUBLIC WORKS SHOP	8.99
			ANCHOR PLAS 12-14-16CD20	
3/04/2025	5/14/2025	5/14/2025	SCREWS FOR PICTURE FRAME IN	1.40
			MAYOR'S OFFICE	
			MISC FASTNERS X8	
3/04/2025	5/14/2025	5/14/2025	FIRE HALL	24.98
			SANDING SPONGE 120GRT 1PK	
			BRUSH VARNISH WOOD 3"W	
3/11/2025	5/14/2025	5/14/2025	PUBLIC WORKS BUILDING	13.99
			BALL VLV BRSS SWEAT 1/2"	
3/12/2025	5/14/2025	5/14/2025	PUBLIC WORKS SHOP	111.28
			DECORA SWITCH	
			PLUG+CPL 1/4"	
			CAM LOCK CA	
			DRAWER LOCK	
			CABLETIE 8"	
			AIR BLOW GUN	
3/17/2025	5/14/2025	5/14/2025	PARK	259.99
			VACUUM SHREDDER	

4/17/2025	5/14/2025	5/14/2025	BUSHING HEX GALV3/8X1/4" HEX BUSHING GLV 1/2X3/8" AIR COUPLER M 1/4" FNPT	15.57
4/17/2025	5/14/2025	5/14/2025	MISC FASTNERS X7 \$10 REWARD CREDIT	0.43
4/22/2025	5/14/2025	5/14/2025	HANDLE TAPR WSTBSKT SWING KITCHEN BAGS LYSOL CRISP LINEN BROOM/DUSTPAN FLR SQUG RPLAC BLADE LED A19 HASP FXD FOOT BOLT	148.09
4/30/2025	5/14/2025	5/14/2025	PINE SOL CLEANER	31.98
4/30/2025	5/14/2025	5/14/2025	NOZZLE SIDE STRIP SPINKLER DUAL 4" PRO HALF	10.58
4/30/2025	5/14/2025	5/14/2025	VALLEY ACE HARDWARE FINANCE CHARGE	7.30

Total for[7304] VALLEY ACE HARDWARE **700.93**

[1167001] VALMONT INDUSTRIES INC

4/22/2025	5/14/2025	5/14/2025	WATER SHUT OFF 10/2023 - CONTINUED TO BE BILLED - REQUESTED REFUND CHECK	1,545.15
-----------	-----------	-----------	--	----------

Total for[1167001] VALMONT INDUSTRIES INC **1,545.15**

[2233] Verizon Wireless

4/04/2025	5/14/2025	5/14/2025	03/05/2025 - 04/04/2025 GENERAL/POLICE	569.51
-----------	-----------	-----------	---	--------

Total for[2233] Verizon Wireless **569.51**

[2240] VRBA Construction

4/25/2025	5/14/2025	5/14/2025	REMOVED CONCRETE DUG UP CORP FROZEN INSTEALLED INSULATION AROUND PIP.SERVICE BACK FILLED/LOAD OF LIMESTONE	4,536.07
4/25/2025	5/14/2025	5/14/2025	CONCRETE REMOVED/WATER MAIN REPAIRED 02/28/2025	6,300.88
4/25/2025	5/14/2025	5/14/2025	2" WATERMAIN REPAIRED 04/18/2025	3,767.25

Total for[2240] VRBA Construction				14,604.20
[679859] Waste Connections of Nebraska Inc				
5/01/2025	5/14/2025	5/14/2025	LIBRARY/CITY HALL/BALLFIELDS MAY 2025	303.40
Total for[679859] Waste Connections of Nebraska Inc				303.40
[2175001] YMCA OF GREATER OMAHA				
4/08/2025	5/14/2025	5/14/2025	YMCA APRIL MEMBERSHIP	50.00
5/02/2025	5/14/2025	5/14/2025	MAY MEMBERSHIP	50.00
Total for[2175001] YMCA OF GREATER OMAHA				100.00
Report Total				543,454.06

Additional Bills for 05/13/2025 Council:

Love's 35488003 - \$219.72

Eakes - \$47.10

Meco-Henne - \$118,530.00

Wiese Plumbing - \$8648.45

Verizon - \$637.03

Love's 3573399 - \$188.89

First Nebraska Bank Credit Card – MGX Equipment - \$250.48

Pay Group: Payroll Period

City of Valley

Gross Wages

Employee

Hourly	\$30,782.39
Salary	\$17,076.92
Cell Phone Reimbursement	\$36.94
Other Taxable	\$913.50
Uniform	\$115.50
Total:	\$48,925.25

Net Pay

Net Check
Direct Deposit

Uncollected

\$0.00

Collected

\$35,599.21

Deductions (included in gross wages)

Uncollected

Collected

2025 IRA 457(b)	\$2,052.33	\$0.00
2025 IRA 457(b) - Roth	\$577.31	\$0.00
AFLAC - Short Term Disability 2025	\$23.76	\$0.00
AFLAC - SPEVNT	\$15.84	\$0.00
AFLAC Accidental 2025	\$43.97	\$0.00
AFLAC Cancer 2025	\$30.54	\$0.00
Dental	\$32.96	\$0.00
Medical	\$535.89	\$0.00
Mutual of Omaha - LIGHT Critical Illness	\$35.99	\$0.00
Mutual of Omaha - LIGHT Life & AD&D	\$0.00	\$0.00
Mutual of Omaha - LIGHT LTD 2024	\$0.00	\$0.00
Mutual of Omaha - Vol Accident	\$33.02	\$0.00
Mutual of Omaha - Voluntary Life & AD&D	\$94.50	\$0.00
Mutual of Omaha LIGHT - STD 2024	\$0.00	\$0.00
MWG - Gap Insurance 2023	\$7.23	\$0.00
Vision	\$3.53	\$0.00
YMCA Membership (In-Network)	\$0.00	\$0.00
Deduction Total:	\$3,990.07	\$0.00

Pay Code: 7796-26870-1514160

Pay Date: 04/04/2025

03/16/2025 through 03/29/2025

Pay Group: Payroll Period

City of Valley

Employee Taxes (included in gross wages)	Uncollected	Collected
Federal	\$0.00	\$3,908.44
Medicare	\$0.00	\$697.48
Social Security	\$0.00	\$2,982.39
State (NE)	\$0.00	\$1,747.66
Employee Tax Total:	\$0.00	\$9,335.97

Employer Taxes	Uncollected	Collected
Medicare	\$0.00	\$697.48
NE-UI	\$0.00	\$40.13
Social Security	\$0.00	\$2,982.39
Employer Tax Total:	\$0.00	\$3,720.00

Grand Totals

Uncollected		Collected	
Checks To Print:	\$0.00	Direct Deposits:	\$35,599.21
Employee Taxes:	\$0.00	Employee Taxes:	\$9,335.97
Employer Taxes:	\$0.00	Employer Taxes:	\$3,720.00
Deductions:	\$3,990.07	Deductions:	\$0.00
		Fees:	\$215.70
		Other Collections:	\$0.00
		Bank Transfer to BambooHR:	\$48,870.88

Pay Group: Payroll Period

City of Valley

Gross Wages

Employee

Hourly	\$29,077.77
Salary	\$17,076.92
Cell Phone Reimbursement	\$36.94
Uniform	\$115.50
Total:	\$46,307.13

Net Pay	Uncollected	Collected
Net Check	\$0.00	
Direct Deposit		\$33,740.89

Deductions (included in gross wages)	Uncollected	Collected
2025 IRA 457(b)	\$1,698.09	\$0.00
2025 IRA 457(b) - Roth	\$577.46	\$0.00
AFLAC - Short Term Disability 2025	\$23.76	\$0.00
AFLAC - SPEVNT	\$15.84	\$0.00
AFLAC Accidental 2025	\$43.97	\$0.00
AFLAC Cancer 2025	\$30.54	\$0.00
Dental	\$32.96	\$0.00
Medical	\$535.89	\$0.00
Mutual of Omaha - LIGHT Critical Illness	\$35.99	\$0.00
Mutual of Omaha - LIGHT Life & AD&D	\$0.00	\$0.00
Mutual of Omaha - LIGHT LTD 2024	\$0.00	\$0.00
Mutual of Omaha - Vol Accident	\$33.02	\$0.00
Mutual of Omaha - Voluntary Life & AD&D	\$94.50	\$0.00
Mutual of Omaha LIGHT - STD 2024	\$0.00	\$0.00
MWG - Gap Insurance 2023	\$7.23	\$0.00
Vision	\$3.53	\$0.00
YMCA Membership (In-Network)	\$0.00	\$0.00
Deduction Total:	\$3,635.98	\$0.00

Pay Group: Payroll Period

City of Valley

Employee Taxes (included in gross wages)	Uncollected	Collected
Federal	\$0.00	\$3,758.36
Medicare	\$0.00	\$659.54
Social Security	\$0.00	\$2,820.02
State (NE)	\$0.00	\$1,692.34
Employee Tax Total:	\$0.00	\$8,930.26

Employer Taxes	Uncollected	Collected
Medicare	\$0.00	\$659.54
NE-UI	\$0.00	\$11.56
Social Security	\$0.00	\$2,820.02
Employer Tax Total:	\$0.00	\$3,491.12

Grand Totals

Uncollected		Collected	
Checks To Print:	\$0.00	Direct Deposits:	\$33,740.89
Employee Taxes:	\$0.00	Employee Taxes:	\$8,930.26
Employer Taxes:	\$0.00	Employer Taxes:	\$3,491.12
Deductions:	\$3,635.98	Deductions:	\$0.00
		Fees:	\$0.00
		Other Collections:	\$0.00
		Bank Transfer to BambooHR:	\$46,162.27

City of Valley

Employee	Hours	Deduction Amount	YTD Total	Employer Amount	Employer YTD Total
2025 IRA 457(b) - Roth					
Cassell, Andrew	80.35	\$79.71	\$542.74	\$0.00	\$0.00
Sorensen, Lori	65.57	\$173.75	\$1,248.24	\$0.00	\$0.00
Stewart, Samantha	80.00	\$143.08	\$974.46	\$0.00	\$0.00
Van Den Boogaart, Jeroen	80.00	\$180.77	\$1,248.04	\$0.00	\$0.00
Grand Total					
Total Count: 4	Grand Total: 305.92	\$577.31	\$4,013.48	\$0.00	\$0.00

* The YTD total does not include employees that did not have a deduction this payroll – please refer to the Payroll Register for a full employee YTD list.

City of Valley

Employee	Hours	Deduction Amount	YTD Total	Employer Amount	Employer YTD Total
2025 IRA 457(b)					
Adams, Brandon	93.80	\$211.59	\$960.81	\$211.59	\$960.81
Cassell, Andrew	80.35	\$0.00	\$0.00	\$79.71	\$542.74
Clark, Caleb	24.63	\$685.66	\$6,365.93	\$44.55	\$413.60
Dohrmann, Kenneth	83.70	\$193.57	\$1,400.19	\$193.57	\$1,400.19
Donnermeyer, Christie	80.00	\$265.39	\$1,836.71	\$159.23	\$1,102.00
Emmi, Sarah	80.28	\$60.72	\$340.25	\$60.72	\$340.25
Musson, James	92.22	\$155.86	\$987.53	\$155.86	\$987.53
Sheets, Tim	87.32	\$177.95	\$1,193.40	\$177.95	\$1,193.40
Sorensen, Lori	65.57	\$0.00	\$0.00	\$104.25	\$748.93
Stewart, Samantha	80.00	\$0.00	\$0.00	\$143.08	\$974.46
Van Den Boogaart, Jeroen	80.00	\$180.77	\$1,248.04	\$216.92	\$1,497.62
Willmann, Geoffrey	83.20	\$120.82	\$794.96	\$120.82	\$794.96
Grand Total					
Total Count: 12	Grand Total: 931.07	\$2,052.33	\$15,127.82	\$1,668.25	\$10,956.49

* The YTD total does not include employees that did not have a deduction this payroll – please refer to the Payroll Register for a full employee YTD list.

City of Valley

Employee	Hours	Deduction Amount	YTD Total	Employer Amount	Employer YTD Total
2025 IRA 457(b) - Roth					
Cassell, Andrew	80.62	\$80.12	\$622.86	\$0.00	\$0.00
Sorensen, Lori	65.47	\$173.49	\$1,421.73	\$0.00	\$0.00
Stewart, Samantha	80.00	\$143.08	\$1,117.54	\$0.00	\$0.00
Van Den Boogaart, Jeroen	80.00	\$180.77	\$1,428.81	\$0.00	\$0.00
Grand Total					
Total Count: 4	Grand Total: 306.08	\$577.46	\$4,590.94	\$0.00	\$0.00

* The YTD total does not include employees that did not have a deduction this payroll – please refer to the Payroll Register for a full employee YTD list.

City of Valley

Employee	Hours	Deduction Amount	YTD Total	Employer Amount	Employer YTD Total
2025 IRA 457(b)					
Adams, Brandon	80.83	\$170.72	\$1,131.53	\$170.72	\$1,131.53
Cassell, Andrew	80.62	\$0.00	\$0.00	\$80.12	\$622.86
Clark, Caleb	14.15	\$393.85	\$6,759.78	\$25.59	\$439.19
Dohrmann, Kenneth	84.02	\$190.10	\$1,590.29	\$190.10	\$1,590.29
Donnermeyer, Christie	80.00	\$265.39	\$2,102.10	\$159.23	\$1,261.23
Emmi, Sarah	80.00	\$60.33	\$400.58	\$60.33	\$400.58
Musson, James	81.73	\$130.94	\$1,118.47	\$130.94	\$1,118.47
Sheets, Tim	87.62	\$178.83	\$1,372.23	\$178.83	\$1,372.23
Sorensen, Lori	65.47	\$0.00	\$0.00	\$104.09	\$853.02
Stewart, Samantha	80.00	\$0.00	\$0.00	\$143.08	\$1,117.54
Van Den Boogaart, Jeroen	80.00	\$180.77	\$1,428.81	\$216.92	\$1,714.54
Willmann, Geoffrey	86.17	\$127.16	\$922.12	\$127.16	\$922.12
Grand Total					
Total Count: 12	Grand Total: 900.60	\$1,698.09	\$16,825.91	\$1,587.11	\$12,543.60

* The YTD total does not include employees that did not have a deduction this payroll – please refer to the Payroll Register for a full employee YTD list.

Commission Summary

Date

4/18/2025



Paid to
City of Valley

For Period
4/1-4/15/2025

Description	Amount
	3,744.84

Amount \$3,744.84

Commission Summary

Date

5/5/2025



Paid to
City of Valley

For Period
4/16-4/30/2025

Description	Amount
	3,084.38

Amount \$3,084.38



Date: May 8, 2025

To: City of Valley

Report by: Jeremy Beam, Lead Operator

O & M Report: April 2025

Water Operation & Maintenance:

- 462 locates were performed this month.
- Meters were read on the 29th, shutoff notices were also handed out. On the 30th we did shutoffs for non-payment.
- We had a water main break in Ginger Woods and another main break on 3rd and Spruce St. Both have been repaired.
- From 2/25/25 – 4/24/25 64 meters have been repaired and now working correctly, we are working on meters every day. Kevin has been working a lot of afterhours to work with residents to get into their homes to repair the meters. Along with this Kindra and our staff have been verifying MXU numbers in the program.
- We had 10 calls for the month for brown water; we have gone out each time and flushed hydrants in their area. Most calls are on Whittingham St. The issue was resolved with the flush.
- There have been close to 10 calls a week to investigate water meter usage for high water bills, we had one location where their water filter was running all the time. Most high usage is due to residence sprinkler systems. We helped one resident change the floats in her toilets because they were running all the time, causing a high water bill.
- All water samples required by the state were done for the month, all were negative of Coliform and E-coli. We also check every other day the Chlorine residual, iron level and manganese levels at the Water Treatment Plant to assure proper treatment of the water.

Wastewater Operation & Maintenance:

- Lift station work orders were done for the month.
- Loves/DQ lift station had a pump pulled due to high amps, the pump was plugged we put the pump back in and was still running high amps. The pump was taken back out and sent in to be looked at for repairs.
- The ozone system at Meigs Street lift station has been piped with stainless steel pipe and is back up and running the floats were also moved to operate the pumps more efficiently.

Recommendations:

- Continue to look for options to improve the water distribution system.

		April-25	March-25	April-24
Water				
	Units			
Total Monthly Pumped Valley	gallons	19,500,000	12,890,000	19,566,000
Daily Average Pumped Valley	gallons	650,000	429,000	586,000
Average Fluoride Residual	mg/L	0.00	0.00	0.00
Fluoride used	lbs	71.70	45.10	72.00
Average Chlorine Residual	mg/L	0.73	0.55	0.45
Chlorine used	lbs	2,931.00	1,692.00	2,305.00
Potassium Permanganate	lbs	563.00	324.00	545.00
Wastewater				
Effluent Flow				
Total Flow Meigs Street	gallons	11,007,000	12,918,000	9,959,000
Avg Daily Flow Meigs Street	gallons	367,000	417,000	332,000
Total Flow Byersville	gallons	16,274,000	13,198,000	16,786,000
Avg Daily Flow Byersville	gallons	542,000	426,000	560,000
Total Flow Valmont	gallons	891,000	874,000	428,780
Avg Daily Flow Valmont	gallons	30,000	28,000	13,831

Contract True-Ups - Current Contract Year				
Item	Budgeted Amount	Amount Spent	% of Budget	% of Time
Maintenance Budget	\$32,162.00	\$7,437.00	23%	58%

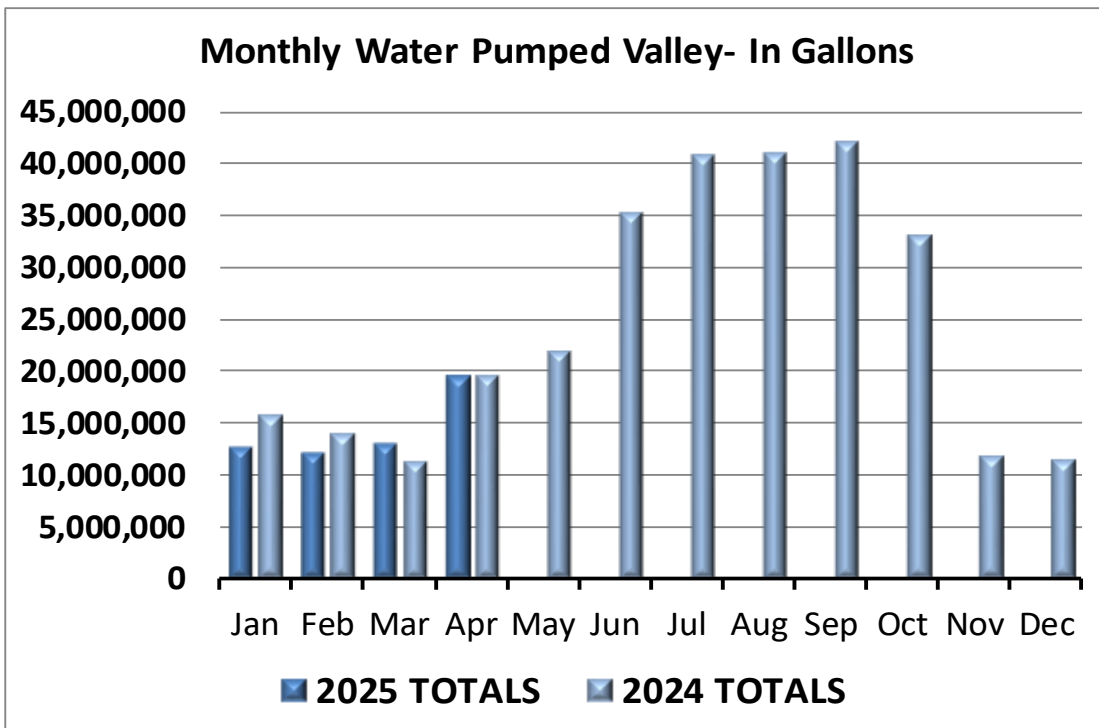
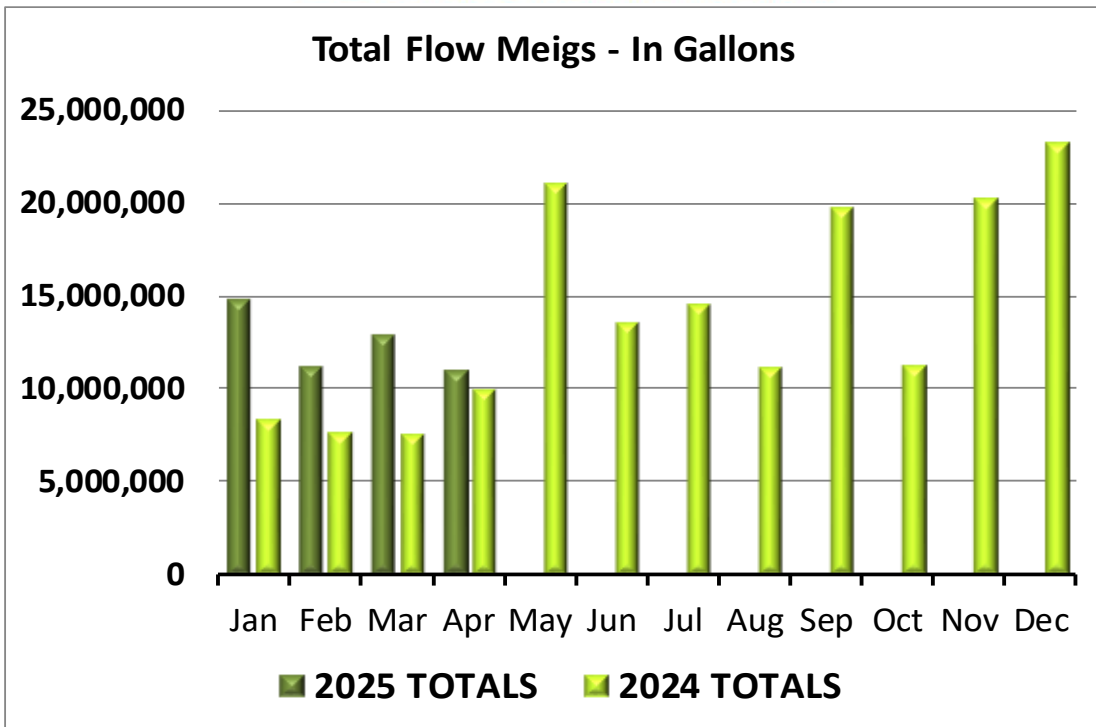

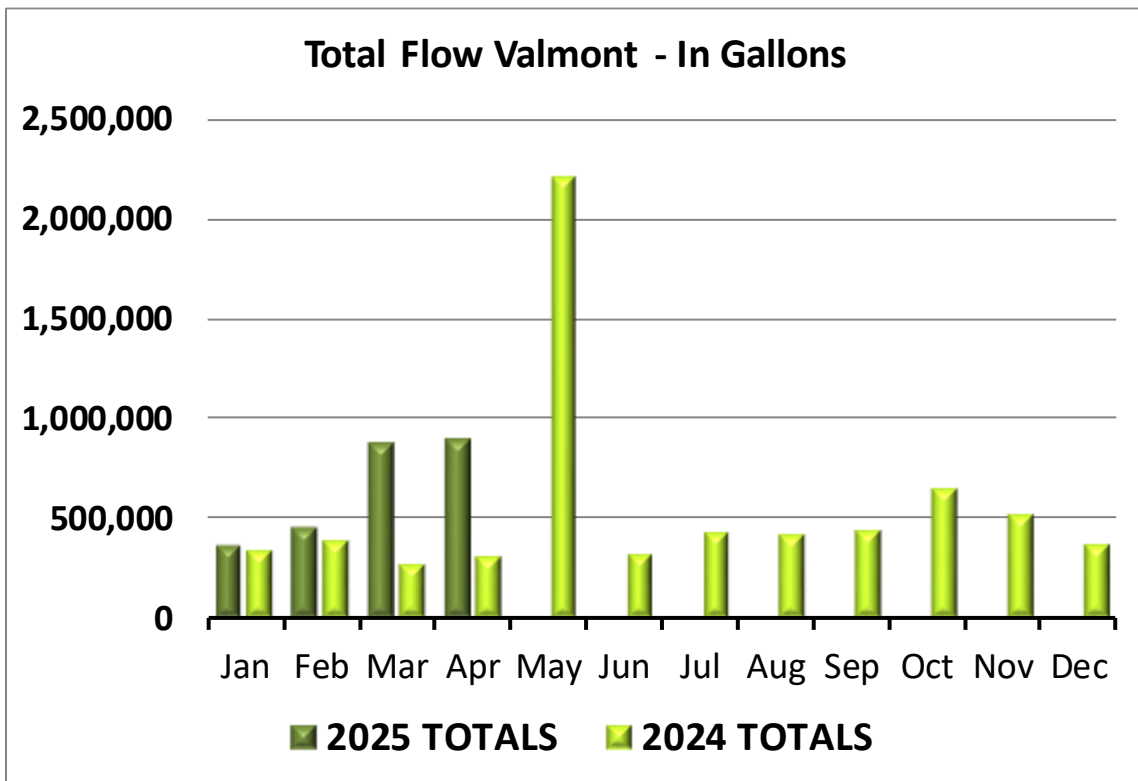
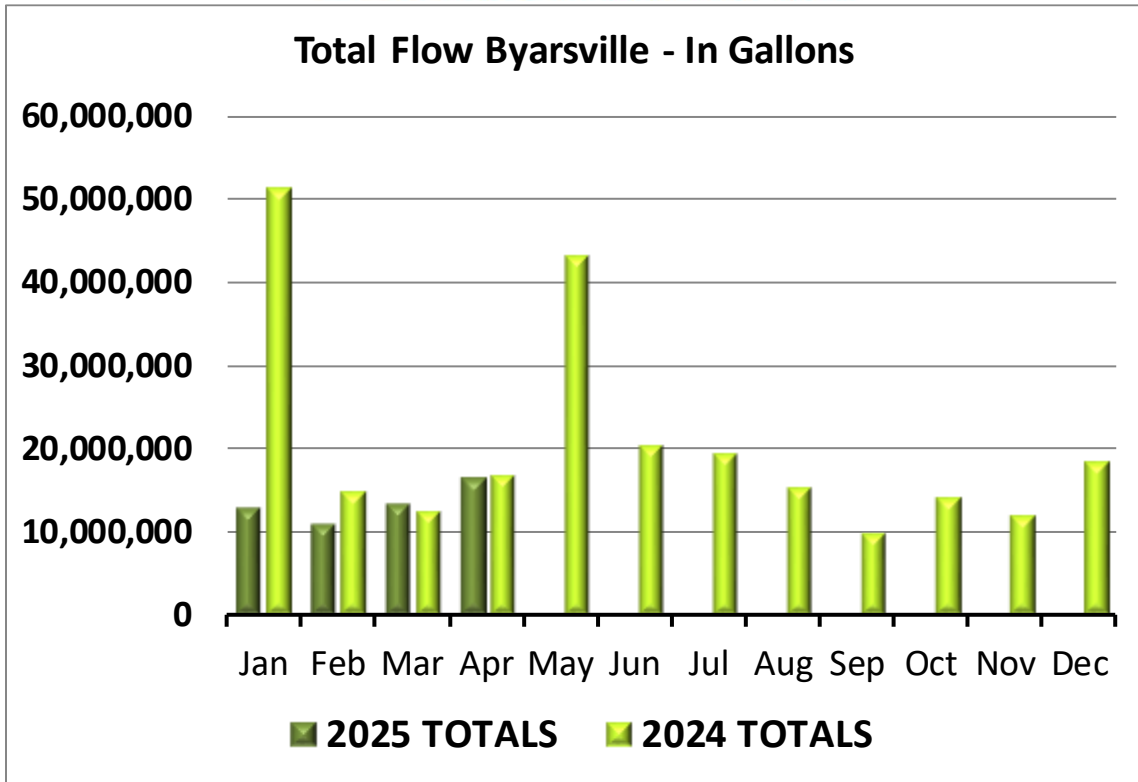

April Work Orders Completed:

Completed	Equipment	Location	Task
04/01/25	AIR COMPRESSOR	30029 WT Valley, NE	Inspection
04/01/25	PORTABLE GAS MONITOR	30029 WT Valley, NE	Calibrate Equipment
04/01/25	FIRE EXTINGUISHERS	30029 WT Valley, NE	Inspection
04/02/25	GINGER WOODS LIFT STATION #3	30029 WW Valley, NE	LS Monthly PM
04/02/25	LIFT STATION #1-VALLEY, NE SYST	30029 WW Valley, NE	LS Monthly PM
04/02/25	VALLEY SHORES LIFT STATION 1	30029 WW Valley, NE	LS Monthly PM
04/02/25	VALLEY SHORES LIFT STATION 2	30029 WW Valley, NE	LS Monthly PM
04/02/25	VALLEY SHORES LIFT STATION 3	30029 WW Valley, NE	LS Monthly PM
04/03/25	BLUEWATER LIFTSTATION 6	30029 WW Valley, NE	LS Monthly PM
04/03/25	BLUEWATER LIFTSTATION 7	30029 WW Valley, NE	LS Monthly PM
04/03/25	GINGER COVE LIFT STATION #1	30029 WW Valley, NE	LS Monthly PM
04/03/25	GINGER COVE LIFT STATION #2	30029 WW Valley, NE	LS Monthly PM
04/03/25	GINGER WOODS LIFT STATION #1	30029 WW Valley, NE	LS Monthly PM
04/03/25	GINGER WOODS LIFT STATION #2	30029 WW Valley, NE	LS Monthly PM
04/04/25	BLUEWATER LIFTSTATION 1	30029 WW Valley, NE	LS Monthly PM
04/04/25	BLUEWATER LIFTSTATION 2	30029 WW Valley, NE	LS Monthly PM
04/04/25	BLUEWATER LIFTSTATION 3	30029 WW Valley, NE	LS Monthly PM
04/04/25	BLUEWATER LIFTSTATION 4	30029 WW Valley, NE	LS Monthly PM
04/04/25	BLUEWATER LIFTSTATION 5	30029 WW Valley, NE	LS Monthly PM
04/07/25	MALLARD LANDING LIFT STATION 4	30029 WW Valley, NE	LS Monthly PM

Completed	Equipment	Location	Task
04/07/25	MALLARD LANDING LIFT STATION 4	30029 WW Valley,	LS Annual PM NE
04/07/25	MEIGS LS EMERGENCY GENERATOR	30029 WW Valley,	LS Monthly PM NE
04/07/25	REGIONAL LS EMERGENCY GENERATOR	30029 WW Valley,	LS Monthly PM NE
04/07/25	VALHAVEN LIFTSTATION	30029 WW Valley,	LS Monthly PM NE
04/08/25	MALLARD LANDING LIFT STATION 3	30029 WW Valley,	LS Annual PM NE
04/08/25	VALLEY SHORES LIFT STATION 1	30029 WW Valley,	LS Annual PM NE
04/08/25	VALLEY SHORES LIFT STATION 2	30029 WW Valley,	LS Annual PM NE
04/08/25	VALLEY SHORES LIFT STATION 3	30029 WW Valley,	LS Annual PM NE
04/09/25	MALLARD LANDING LIFT STATION 3	30029 WW Valley,	LS Monthly PM NE
04/10/25	BYERSVILLE LS EMERGENCY GENERATOR	30029 WW Valley,	LS Monthly PM NE
04/10/25	COUNTRY AIRE LIFTSTATION	30029 WW Valley,	LS Monthly PM NE
04/10/25	DAIRY QUEEN LIFTSTATION	30029 WW Valley,	LS Monthly PM NE
04/10/25	MALLARD LANDING LIFT STATION 1	30029 WW Valley,	LS Monthly PM NE
04/10/25	MALLARD LANDING LIFT STATION 1	30029 WW Valley,	LS Annual PM NE
04/10/25	MALLARD LANDING LIFT STATION 2	30029 WW Valley,	LS Monthly PM NE
04/10/25	MALLARD LANDING LIFT STATION 2	30029 WW Valley,	LS Annual PM NE

DAILY RECORDS**April 2025**

		This month	Last month	Last year
LIBRARY VISITS:				
	Adults	530	432	491
	Children	450	350	553
Computers	Adults	72	46	51
	Children	67	83	95
Fax/Copies		62	62	71

REFERENCE TRANSACTIONS

Locating Library Materials		80	55	86
Readers' Advisory		34	9	38
Account info and renewals		32	12	19
Technology Assistance		81	48	102
Local Info		47	20	40
General Info		378	349	265
	Total	652	493	550

TOTAL NUMBER OF LIBRARY PROGRAMS:

Adults	6	6	5
Teens	11	5	5
Children	10	8	9
Pre-K	6	3	3
Total	33	22	22

TOTAL PROGRAM ATTENDANCE:

Adults	33	32	27
Teens	50	26	47
Children	69	54	120
Pre-K	121	19	81
Total	273	131	275

NEW PATRONS

Valley	8	5	9
Douglas County	3	1	2
Non-Douglas County	1	0	0
Total	12	6	11

Volunteers/hours	5/5	5/5	0/0
-------------------------	------------	------------	------------

MATERIALS CHECKED OUT:

Adult	781	731	728
Children	976	862	1762
Overdrive	376	440	311

CITY OF VALLEY
VALLEY PLANNING COMMISSION MINUTES
March 18, 2025

1 and 2. Roll Call and Call to Order: Larry Bottger, Chairman, Scott Burke, Kyle Anderson, Mark Conrey, Greg Sunde, Daniell Lowry. Absent: Jim Tomanek, Brian Foutch, and Jeremy Mayer. Also present: Mayor Cindy Grove, Building Inspector Rune van den Boogaart, City Engineer Greg Perry, City Administrator Cameron Gales, and City Attorneys Jeff Farnham and Andrea Griffin.

Chairman Bottger noted the location of the open meetings act, and stated one copy of all reproducible written material to be discussed at this meeting is available for examination or copying.

3. Pledge of Allegiance: The Pledge of Allegiance was recited.

4. Proof of Publication: The Proof of Publication was on the desk.

5. Visitors/Correspondence: No one spoke.

6. Approval of Agenda: Member Anderson moved to approve the agenda. Burke seconded. YES: Bottger, Burke, Anderson, Conrey, Sunde and Lowry. NO: no one. ABSENT: Tomanek, Foutch and Mayer. Motion carried.

7. Consent Agenda: Member Sunde moved to approve the consent agenda. Conrey seconded. YES: Bottger, Burke, Anderson, Conrey, Sunde and Lowry. NO: no one. ABSENT: Tomanek, Foutch and Mayer. Motion carried. Items on the consent agenda: February 18, 2025 meeting minutes.

8. Discussion Items:

Rune van den Boogaart, Building and Zoning Administrator, discussed updates to the current building codes and the difficulty in making mass updates to the code.

Jeff Farnham, City Attorney, discussed the current development climate and potential amendments to the current Comprehensive Development Plan. Jeff provided an overview of what a Sanitary Improvement District (SID) is and how the Comprehensive Development Plan could be amended regarding the use of SIDs. Greg Perry, City Engineer, also provided an update on current blighted properties and the percentage of blighted property in the City.

Andrea Griffin, City Attorney, presented an update on the current TIF projects and their current property valuations for 2025. Current TIF projects are rolling TIFs. Two new TIF projects are Catalina and Valley Landing.

Member Sunde moved to adjourn. Anderson seconded. YES: Bottger, Burke, Anderson, Conrey, Sunde and Lowry. NO: no one. ABSENT: Tomanek, Foutch and Mayer. Motion carried.



Larry Bottger, Chairman



Cindy Grove
Mayor

March 13th, 2025 Valley Public Library Board of Trustees Minutes

Call to Order: President, Kyle Held, called the meeting to order at 6:32 p.m.

Roll Call: Trustees answering roll call: Kyle Held, Haley Cortez, and James Musson. Librarian, Sami Stewart was also in attendance. Moria Winters and Theresa Samson were absent.

Proof of Posting/Open Meetings Act Poster: The meeting was held in accordance with the Nebraska Open Meetings Law, with meeting notice posted in the library windows and on website. Continuously updated copies of the agenda were maintained on the library's bulletin board and the library's website.

Approval of Agenda: Motion to approve by J. Musson seconded by H. Cortez. Yeas: K. Held, H. Cortez, and J. Musson. Nays: None. Motion carried 3-0. There were no consent agenda items which required approval.

Recognition of Visitors/Correspondence: Guests in attendance were Tammi Thiem, Director of Three Rivers Library System, and Celeste Viviano, Practicum Student.

Public Comment: None was given.

Approval of Prior Meetings Minutes: Motion to approve the November minutes was made by H. Cortez, seconded by J. Musson. Yeas: K. Held, J. Musson, and H. Cortez. Nays: none. Motion carried 3-0.

Reports

A. **Board President:** No official report.

B. **Library Director:** S. Stewart had emailed the Librarian's report; she then went over verbally and answered questions. She reminded board members that they have 20 hours of continuing education to complete by August.

C. **Friends of the Library:** No official report. Friends asked if they could have permission to paint the "Guess Who" wall near the circulation desk into a chalkboard wall. Board members present indicated that they didn't see an issue with the proposal.

D. **Foundation:** No official report.

Old Business:

A. None.

New Business

A. Tammi Thiem Breakout Box Training – T. Thiem presented her breakout box challenge based on the United for Libraries training content for library trustees. Each board member present earned 1 hour of CE credit.

Comments and Announcements by Board Members:

None.

Meeting Adjournment was announced by President, K. Held at 7:44 p.m.

Next meeting will be May 8th, 2025 at 6:30pm.

Respectfully submitted,

Sami Stewart, acting as Secretary

SDL – LOCAL RECOMMENDATION

NEBRASKA LIQUOR CONTROL COMMISSION
301 CENTENNIAL MALL SOUTH
PO BOX 95046
LINCOLN, NE 68509-5046
PHONE: (402) 471-2571
FAX: (402) 471-2814
EMAIL: lcc.sdl.licensing@nebraska.gov
WEBSITE: www.lcc.nebraska.gov

153341

Claude H. Montgomery Post No 58 The American Legion

License #

Licensee Name/Non-Profit Organization

Event location name: Valley Veteran's Club

Event address/location: 111 E Front Street Valley, NE 68064

Event Type: Fundraiser

Event date(s): 07/19/25

Event start time(s): 12:00 p.m.

Event end time(s): 12:00 a.m.

Indoor area to be licensed in length & width: 120 X 150

Outdoor area to be licensed in length & width: _____ X _____ (Must submit a diagram)

Estimated number of attendees: 150

Alternate dates/times: _____

Alternate location name/location: _____

Type of alcohol to be served: Beer XX Wine XX Distilled Spirits XX

Event contact name: Dick Rowe Event contact phone number: 402-490-5324

Event contact Email: dodgerfanforever42@gmail.com

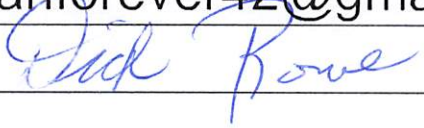
*Signature Authorized Representative: 

Local Governing Body completes below:

The local governing body for the City of Valley OR
County of _____ approves the issuance of a Special Designated License as
requested above.

Local Governing Body Authorized Signature

05/13/2025

Date

SDL – LOCAL RECOMMENDATION

NEBRASKA LIQUOR CONTROL COMMISSION
301 CENTENNIAL MALL SOUTH
PO BOX 95046
LINCOLN, NE 68509-5046
PHONE: (402) 471-2571
FAX: (402) 471-2814
EMAIL: lcc.sdl.licensing@nebraska.gov
WEBSITE: www.lcc.nebraska.gov

153341

Claude H. Montgomery Post No 58 The American Legion

License #

Licensee Name/Non-Profit Organization

Event location name: **Valley Veteran's Club**

Event address/location: **111 E Front Street Valley, NE 68064**

Event Type: **Fundraiser**

Event date(s): **08/16/25**

Event start time(s): **12:00 p.m.**

Event end time(s): **12:00 a.m.**

Indoor area to be licensed in length & width: **120** X **150**

Outdoor area to be licensed in length & width: _____ X _____ (Must submit a diagram)

Estimated number of attendees: **150**

Alternate dates/times: _____

Alternate location name/location: _____

Type of alcohol to be served: Beer **XX** Wine **XX** Distilled Spirits **XX**

Event contact name: **Dick Rowe** Event contact phone number: **402-490-5324**

Event contact Email: **dodgerfanforever42@gmail.com**

*Signature Authorized Representative: *Dick Rowe*

Local Governing Body completes below:

The local governing body for the City of Valley OR
County of _____ approves the issuance of a Special Designated License as
requested above.

05/13/2025

Local Governing Body Authorized Signature

Date

SDL – LOCAL RECOMMENDATION

NEBRASKA LIQUOR CONTROL COMMISSION
301 CENTENNIAL MALL SOUTH
PO BOX 95046
LINCOLN, NE 68509-5046
PHONE: (402) 471-2571
FAX: (402) 471-2814
EMAIL: lcc.sdl.licensing@nebraska.gov
WEBSITE: www.lcc.nebraska.gov

153341

Claude H. Montgomery Post No 58 The American Legion

License #

Licensee Name/Non-Profit Organization

Event location name: Valley Veteran's Club

Event address/location: 111 E Front Street Valley, NE 68064

Event Type: Fundraiser

Event date(s): 09/20/25

Event start time(s): 12:00 p.m.

Event end time(s): 12:00 a.m.

Indoor area to be licensed in length & width: 120 X 150

Outdoor area to be licensed in length & width: _____ X _____ (Must submit a diagram)

Estimated number of attendees: 150

Alternate dates/times: _____

Alternate location name/location: _____

Type of alcohol to be served: Beer XX Wine XX Distilled Spirits XX

Event contact name: Dick Rowe Event contact phone number: 402-490-5324

Event contact Email: dodgerfanforever42@gmail.com

*Signature Authorized Representative: *Dick Rowe*

Local Governing Body completes below:

The local governing body for the City of Valley OR
County of _____ approves the issuance of a Special Designated License as
requested above.

05/13/2025

Local Governing Body Authorized Signature

Date

SDL – LOCAL RECOMMENDATION

NEBRASKA LIQUOR CONTROL COMMISSION
301 CENTENNIAL MALL SOUTH
PO BOX 95046
LINCOLN, NE 68509-5046
PHONE: (402) 471-2571
FAX: (402) 471-2814
EMAIL: lcc.sdl.licensing@nebraska.gov
WEBSITE: www.lcc.nebraska.gov

153341

Claude H. Montgomery Post No 58 The American Legion

License #

Licensee Name/Non-Profit Organization

Event location name: **Valley Veteran's Club**

Event address/location: **111 E Front Street Valley, NE 68064**

Event Type: **Fundraiser**

Event date(s): **10/18/25**

Event start time(s): **12:00 p.m.**

Event end time(s): **12:00 a.m.**

Indoor area to be licensed in length & width: **120** X **150**

Outdoor area to be licensed in length & width: _____ X _____ (Must submit a diagram)

Estimated number of attendees: **150**

Alternate dates/times: _____

Alternate location name/location: _____

Type of alcohol to be served: Beer **XX** Wine **XX** Distilled Spirits **XX**

Event contact name: **Dick Rowe** Event contact phone number: **402-490-5324**

Event contact Email: **dodgerfanforever42@gmail.com**

*Signature Authorized Representative: *Dick Rowe*

Local Governing Body completes below:

The local governing body for the City of Valley OR
County of _____ approves the issuance of a Special Designated License as
requested above.

05/13/2025

Local Governing Body Authorized Signature

Date

SDL – LOCAL RECOMMENDATION

NEBRASKA LIQUOR CONTROL COMMISSION
301 CENTENNIAL MALL SOUTH
PO BOX 95046
LINCOLN, NE 68509-5046
PHONE: (402) 471-2571
FAX: (402) 471-2814
EMAIL: lcc.sdl.licensing@nebraska.gov
WEBSITE: www.lcc.nebraska.gov

153341

Claude H. Montgomery Post No 58 The American Legion

License #

Licensee Name/Non-Profit Organization

Event location name: Valley Veteran's Club

Event address/location: 111 E Front Street Valley, NE 68064

Event Type: Fundraiser

Event date(s): 11/15/25

Event start time(s): 12:00 p.m.

Event end time(s): 12:00 a.m.

Indoor area to be licensed in length & width: 120 X 150

Outdoor area to be licensed in length & width: _____ X _____ (Must submit a diagram)

Estimated number of attendees: 150

Alternate dates/times: _____

Alternate location name/location: _____

Type of alcohol to be served: Beer XX Wine XX Distilled Spirits XX

Event contact name: Dick Rowe Event contact phone number: 402-490-5324

Event contact Email: dodgerfanforever42@gmail.com

*Signature Authorized Representative: *Dick Rowe*

Local Governing Body completes below:

The local governing body for the City of Valley OR
County of _____ approves the issuance of a Special Designated License as
requested above.

05/13/2025

Local Governing Body Authorized Signature

Date

SDL – LOCAL RECOMMENDATION

NEBRASKA LIQUOR CONTROL COMMISSION
301 CENTENNIAL MALL SOUTH
PO BOX 95046
LINCOLN, NE 68509-5046
PHONE: (402) 471-2571
FAX: (402) 471-2814
EMAIL: lcc.sdl.licensing@nebraska.gov
WEBSITE: www.lcc.nebraska.gov

153341

Claude H. Montgomery Post No 58 The American Legion

License #

Licensee Name/Non-Profit Organization

Event location name: Valley Veteran's Club

Event address/location: 111 E Front Street Valley, NE 68064

Event Type: Fundraiser

Event date(s): 12/20/25

Event start time(s): 12:00 p.m.

Event end time(s): 12:00 a.m.

Indoor area to be licensed in length & width: 120 X 150

Outdoor area to be licensed in length & width: _____ X _____ (Must submit a diagram)

Estimated number of attendees: 150

Alternate dates/times: _____

Alternate location name/location: _____

Type of alcohol to be served: Beer XX Wine XX Distilled Spirits XX

Event contact name: Dick Rowe Event contact phone number: 402-490-5324

Event contact Email: dodgerfanforever42@gmail.com

*Signature Authorized Representative: *Dick Rowe*

Local Governing Body completes below:

The local governing body for the City of Valley OR
County of _____ approves the issuance of a Special Designated License as
requested above.

05/13/2025

Local Governing Body Authorized Signature

Date

From: Valley City Office [cityoffice@valleyne.org]
To: Cindy Grove [mayor@valleyne.org], Christie Donnermeyer [cdonnermeyer@valleyne.org],
Cameron Gales [cgales@valleyne.org]
Subject: Council Agenda Request Seth Weldon
Sent: Tue 4/8/2025 12:50 PM GMT-05:00
Importance: Normal

Name: Seth Weldon
Phone: 4023544263
Email Address: seth.weldon@nmhs.org
Address: 8303 Dodge St. Omaha, NE, 68114
Agenda Item Description: Update on the 2025 Rollin' To Colon Annual bike ride scheduled for
June 29th, 2025
Requested Action: Recognition/Acknowledgement of support of the event
Does this require an expenditure of funds: No

[View in List](#)

From: Valley City Office [cityoffice@valleyne.org]
To: Cindy Grove [mayor@valleyne.org], Christie Donnermeyer [cdonnermeyer@valleyne.org],
Cameron Gales [cgales@valleyne.org]
Subject: Council Agenda Request Nick Stanzel
Sent: Mon 5/5/2025 3:25 PM GMT-05:00
Importance: Normal

Name: Nick Stanzel

Phone: 4026205951

Email Address: vfrd505@gmail.com

Address: 401 E Meigs St

Agenda Item Description: Per Valley Fire Dept. Road closure of N Spruce St for a training burn on 05/24/2025

Requested Action: VFD would like to permission from the council to close a portion of N Spruce Street North of Reichmuth Rd for a training burn, Address of the burn house is 701 N Spruce St.

We would also like to borrow 4 road closure signs from public works, approx. length of road closed will be 0.2 miles. Time of closure will be 8:00am to 3:00pm on the 24th of May.

Does this require an expenditure of funds: No

[View in List](#)

Christie Donnermeyer

From: Valley City Office
Sent: Tuesday, May 6, 2025 10:13 AM
To: Cindy Grove; Christie Donnermeyer; Cameron Gales
Subject: Council Agenda Request Angela Exstrom

Name: Angela Exstrom

Phone: 402-881-5921

Email Address: aexstrom@yahoo.com

Address: 502 S Park Ave Valley, NE 68064

Agenda Item Description: Valley Days Sponsorship Request

Requested Action: The Valley Days Foundation requests the City Council approve payment of \$5,000 budgeted from Keno funds to support the 2025 Valley Days event on August 8, 9 and 10. Funds are not co-mingled with other events and used strictly for the Valley Days event. Supporting the event through the annual donation will ensure the event will continue without the use of city staff time to plan and fund such event.

Does this require an expenditure of funds: Yes

[View in List](#)



2025 Annual Valley Days Sponsorship Request

Background

In 2015, the annual Valley Days event was revived as a city sponsored and funded event. It was originally coordinated in conjunction with the Valley Veteran's BBQ competition, which was also a city event. Both events were funded through Keno funds and business sponsorships, obtained by city staff. The event was primarily coordinated by city staff as well.

In 2018 the use of Keno funds to fully fund these events was in jeopardy therefore a group of residents came together to form the Valley Days Foundation, a non-profit organization dedicated to coordinating and funding community events and community betterment in the City of Valley.

The attached proposal was presented to former Mayor Carroll Smith and City Clerk Joan Suhr in July 2018. Both agreed with the proposal and the City began using \$5,000 of Keno funds to support the annual event.

Request

The Valley Days Foundation requests the City Council approve payment of \$5,000 budgeted from Keno funds to support the 2025 Valley Days event on August 8, 9 and 10. Funds are not co-mingled with other events and used strictly for the Valley Days event. Supporting the event through the annual donation will ensure the event will continue without the use of city staff time to plan and fund such event.

Mission

The Valley Days Foundation is a non-profit organization dedicated to coordinating and funding community events and community betterment in the City of Valley, Nebraska.

Board Members

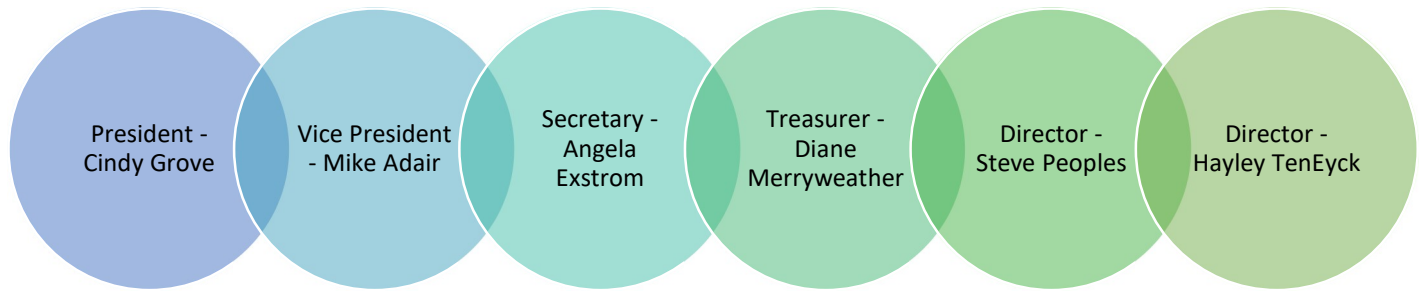

Partnership with the City of Valley

City may donate a set amount annually to be listed as the host / major sponsor - Foundation will reserve this sponsor level for the City as long as they want it.

Foundation will be responsible for keeping track of funds and budget taking that responsibility off the City

Coordination of the annual event will continue to be similar as it is today with the input of the Mayor and City Clerk

Foundation will be responsible for all fundraising efforts and events will be planned based on funds raised; this will eliminate the City from having to utilize funds over the budgeted amount and City resources to conduct fundraising.

City will continue to provide assistance for the event through Public Works employees and Police as they do today.

Funds not used for the year's event will be carried over by the Foundation for future years instead of going towards other City events.

Comparison to other Cities

Gretna

- Organized by Gretna Days Foundation.
- 501(c)4 Charity.
- Board members are local business owners

Elkhorn

- Organized by a committee of volunteers
- Funds are raised and coordinated through the committee with an unofficial board.

Millard

- Organized by Millard Days, Inc
- Millard Days Committee is a non-profit organization
- Extra funds go to grants for community betterment and scholarships

Bennington

- Organized by Bennington Daze, Inc.
- Non-profit corporation

Christie Donnermeyer

From: Valley City Office
Sent: Tuesday, May 6, 2025 12:13 PM
To: Cindy Grove; Christie Donnermeyer; Cameron Gales
Subject: Council Agenda Request Rich Hudson

Name: Rich Hudson

Phone: 402.306.0298

Email Address: rhhudson@msn.com

Address: 26534 Manderson Ct Valley, NE 68064

Agenda Item Description: Mallard Landing Lake Community/HOA is requesting permission to hold an Independence Day Celebration on July 5th, 2025. Our community event will start with a parade from 9 AM to 12 PM, in which we will be requesting street closures in our development, then ending with a fireworks show at or before 10 PM. The fireworks show would last approximately 15-20 minutes. As per City Code 130.058 (C)(2) Notwithstanding other rules, consumer fireworks may be used or discharged only on June 25 through July 4 and December 28 through December 30, inclusive, between the hours of 8:00 a.m. and 10:00 p.m. on those days and from 8:00 a.m. on December 31 through 12:30 a.m. on January 1. We would need special permission from the City Council to hold this Independence Day Celebration event on the day after what the code allows. We would like to request a rain date on July 6th in the event of any storm activity prevents our celebration.

Requested Action: Approval of the parade street closures and fireworks to be held on July 5th. Street closures will need to be barricaded by the city as described: starting at Taylor Circle, continuing down N 269th to Ruggles, from Ruggles picking back up on N 269th, then turning east on Manderson Street, ending at 267th Circle. The street closure times for our parade would be from 9:00 AM – 12:00 PM. The fireworks display is expected to start at approximately 10:00 PM and last for 15-20 minutes. As stated in the agenda description, we would like to request a rain date on July 6th in the event of any storm activity preventing our celebration.

Does this require an expenditure of funds: Unsure

[View in List](#)

Christie Donnermeyer

From: Martha Walker <marthajwalker8@gmail.com>
Sent: Thursday, May 8, 2025 8:41 AM
To: Christie Donnermeyer
Subject: Ginger Cove Block Party Street Closing Request - Island Circle Only

Follow Up Flag: Follow up
Flag Status: Flagged

EXTERNAL EMAIL

Hi:

I am a resident of Ginger Cove and requesting a block party street closing request for the island circle (area from house numbers #7 - #17 Ginger Cove Road), for Saturday, June 21st from 5-10pm.

The event is a neighborhood family centered luau themed party including a band playing from 7-10pm, food being catered and fun activities for children. There will also be a Kona Ice truck serving slushies from 5:30 - 7:30pm. We will be renting porta potties and extra trash cans for the event. It will all be held in the grassy area on the circle including the band and setup, but we want no vehicles driving around the circle during the event. Should we need any emergency vehicles, they would easily be able to drive through the circle. All neighbors from #7 thru #17 have been notified of this event and what it entails.

I would ask that you let me know the steps for approval and where to locate an application for a permit.

Thanks,
MJ Walker
#11 Ginger Cove Road
(913) 530-8880

Sent from my iPhone

PROCLAMATION

INTERNATIONAL BUILDING SAFETY MONTH

MAY 2025

WHEREAS the safety of the buildings we occupy daily is essential to the health, safety, and welfare of the citizens of the world, and

WHEREAS among the world's most fundamental laws are those providing safety standards for the construction of buildings in which people live, work and play, and

WHEREAS for construction codes to be effective and enforced, understanding and cooperation must exist between code officials and the people they serve, and

WHEREAS through the efforts of code officials worldwide, and their cooperative relationship with the construction industry, the administration of these health and life-safety standards is assured, and

WHEREAS units of government across the world – along with such prestigious organizations as International Code Council, Nebraska Code Officials Association and Board of Engineers and Architects - are joining to promote the use of building and construction codes today, through the observation of International Building Safety Month.

NOW THEREFORE be it resolved that I, Cindy Grove, Mayor of the City of Valley, along with my fellow Council Members, do here by proclaim the month of May 2025, **INTERNATIONAL BUILDING SAFETY MONTH**. I urge all citizens to participate in International Building Safety Month activities to promote building safety, to create awareness as to the importance of construction and building codes, and to spotlight the role of the dedicated code official in administering those codes.

DATED THIS 13th DAY OF MAY 2025.

Cindy Grove, Mayor
City of Valley

PROCLAMATION

Mental Health Month 2025

“Look Around, Look Within”

WHEREAS, the area that someone lives in plays a significant role in their overall health and well-being; and

WHEREAS, surroundings can impact if, how, and when a person’s needs are met, which in turn affects mental health; and

WHEREAS, having safe, stable, and healthy home conditions set the foundation for achieving and maintaining good mental health; and

WHEREAS, with early and effective interventions, those individuals with mental health conditions can recover and lead full, productive lives; and

WHEREAS, each business, school, government agency, health care provider, organization, and citizen share the burden of mental health problems and has a responsibility to promote mental wellness and support prevention efforts.

NOW THEREFORE I Cindy Grove, Mayor of the City of Valley, do hereby proclaim May 2025 as Mental Health Month in the City of Valley. As the Mayor, I also call upon the citizens, government agencies, public and private institutions, businesses, and schools in the City of Valley to recommit our community to increasing awareness and understanding of mental health, the steps our citizens can take to protect their mental health, and the need for appropriate and accessible services for all people with mental health conditions.

DATED THIS 13TH DAY OF MAY 2025.

Cindy Grove, Mayor
City of Valley

PROCLAMATION

PEACE OFFICERS' MEMORIAL DAY and NATIONAL POLICE WEEK

MAY 15, 2025 and MAY 11-17, 2025

WHEREAS the Congress and President of the United States have designated May 15th as Peace Officers' Memorial Day, and the week in which May 15th falls as National Police Week; and

WHEREAS the members of the **Valley Police Department** play an essential role in safeguarding the rights and freedoms of all citizens in the City of Valley; and

WHEREAS it is important that all citizens know and understand the duties, responsibilities, hazards, and sacrifices of their law enforcement agency and that members of our law enforcement agency recognize their duty to serve the people by safeguarding life and property by protecting them against violence and disorder, and by protecting the innocent against deception and the weak against oppression; and

WHEREAS the Valley Police Department has grown to be a modern and scientific law enforcement agency which unceasingly provides a vital public service.

NOW THEREFORE be it resolved that I, Cindy Grove, Mayor of the City of Valley, along with my fellow Council Members, do hereby proclaim the week of May 11-17, 2025 **PEACE OFFICERS' MEMORIAL DAY and NATIONAL POLICE WEEK**. I encourage everyone to join in commemorating law enforcement officers, past and present, who, by their faithful and loyal protection, have rendered a dedicated service to their communities and, publicly salutes the service of law enforcement officers in our community and in communities across the nation.

DATED THIS 13TH DAY OF MAY 2025.

Cindy Grove, Mayor
City of Valley



CERTIFICATE OF APPRECIATION PRESENTED TO

Geoffrey Willmann

FOR YOUR DEDICATION AND CONTRIBUTION TO THE DEPARTMENT

In recognition of your outstanding leadership and initiative in organizing the Valley Police Department's participation in the 2025 University of Omaha Job Fair. Your efforts not only showcased the professionalism and dedication of our department but also strengthened community outreach and inspired future public servants. Your commitment to excellence and collaboration is sincerely appreciated. Thank you for your dedication, service, and the positive impact you continue to have on the department.

PRESENTED BY THE CITY OF VALLEY, NEBRASKA

MAY 13, 2025

Cindy Grove, Mayor

Bobby Martinez, Chief of Police



CERTIFICATE OF APPRECIATION PRESENTED TO

Austin Kelley

FOR YOUR EXEMPLARY DEDICATION TO THE COMMUNITY

Your exceptional vigilance, compassion, and decisive action while on routine patrol. On May 1, 2025, Officer Kelley observed a vehicle on the roadside with hazard lights activated. Demonstrating initiative and care, Officer Kelley stopped and discovered a juvenile experiencing a severe mental health crisis and intending to end his life. Officer Kelley quickly called for a mental health expert to respond and stayed with the juvenile until a co-responder arrived on-scene. Your calm, professional, and empathetic response not only prevented a tragedy but exemplified the highest standards of law enforcement. Your actions reflect great credit upon yourself, Valley Police Department, and the policing profession. This certificate is presented with sincere appreciation for your commitment to the safety and well-being of all members of the community.

PRESENTED BY THE CITY OF VALLEY, NEBRASKA

MAY 13, 2025

Cindy Grove, Mayor

Bobby Martinez, Chief of Police



April 11, 2025

Officer Brandon Adams
Valley Police Department
203 N. Spruce St., Valley, NE 68064

Dear Officer Brandon Adams,

Great news! You've been selected as the recipient of the 2025 MADD Hero Award! The Hero Award Selection Committee was blown away by the quality of nominations this year, and after going through them all, they decided that your work deserves the MADD 2025 Hero Award in the Adult DUI/DWI Individual category.

Mark your calendar because the Annual MADD Hero Awards Ceremony will be on May 20th at Wilderness Ridge in Lincoln, from 2:00 to 4:00 pm. Keep an eye out for a formal invitation coming your way soon. And if there's anyone special that you'd like to invite (limit 2 guests per recipient), please send us their names and mailing addresses by April 30th at ne.state@madd.org, and we'll make sure they get an invite too. Additionally, if all award winners could please send a headshot for our slideshow to be presented during the ceremony, we would greatly appreciate it.

We're honored to have the chance to recognize the incredible work happening right here in our state. Your efforts in preventing impaired driving and underage drinking and other substance use are making a real difference in keeping our communities safer. On behalf of MADD Nebraska and all the victims we serve, thank you for being a hero in this fight.

We cannot wait to celebrate your achievements with you at the ceremony!

With respect,

Ashley Rowe,
MADD Nebraska, Program Manager

ORDINANCE NO. 837

AN ORDINANCE OF THE CITY OF VALLEY, NEBRASKA, REPEALING SECTION 31.22 OF THE VALLEY MUNICIPAL CODE. AN ORDINANCE ADOPTING REVISED SECTION 31.22 PUBLIC WORKS SUPERINTENDENT, RELATING TO THE RESPONSIBILITIES OF THE PUBLIC WORKS SUPERINTENDENT; PROVIDING FOR AN EFFECTIVE DATE OF THIS ORDINANCE; PROVIDING FOR A SEVERABILITY CLAUSE; AND PROVIDING FOR THE REPEAL OF ALL ORDINANCES IN CONFLICT HEREWITH.

BE IT ORDAINED BY THE MAYOR AND CITY COUNCIL OF VALLEY, DOUGLAS COUNTY, NEBRASKA, AS FOLLOWS:

Section 1. Section 31.22 of the Valley Municipal Code is hereby repealed.

Section 2. Section 31.22 of the Valley Municipal Code shall hereafter be as follows:

31.22 PUBLIC WORKS SUPERINTENDENT.

There is hereby established in the City of Valley, Nebraska, the position of Public Works Superintendent, such position shall be responsible for the following departments: Streets, Arboretum, Parks, Pool, Cemetery, and Animal Control in the City of Valley.

(A) Under the direction of the Mayor, City Council, and the City Administrator, the Public Works Superintendent performs technical and supervisory work directing and managing Public Works programs and activities, including street maintenance, public grounds and facilities, including park maintenance, pool maintenance and equipment maintenance.

(B) In the performance of this employee's role as Public Works Superintendent he/she shall have the following duties and responsibilities:

- (1) Develop and implement policies, departmental goals, and objectives as well as plans to achieve those goals.
- (2) Develop and implement policies and procedures designed to ensure the efficient operation of the department.
- (3) Perform and oversee personnel management functions including hiring employees, planning, scheduling and assigning work duties, training employees, conducting performance evaluations and handling disciplinary actions.
- (4) Coordinate with key staff to prepare and administer the annual departmental operating budget.
- (5) Supervise public works staff and provide guidance on maintaining performance standards.

- (6) Prepare special reports regarding public works activities and make appropriate recommendations to the City Administrator.
 - (7) Maintain records, develop maintenance programs and budgets, allocate public works resources, and report on and evaluate the performance of public works functions.
 - (8) Knowledge of current trends and developments in job-related skills and techniques.
- (C) The Public Works Superintendent may also be referenced as the Public Works Director.

Section 3. This ordinance shall be in full force and effect from and after its passage, approval and publication or posting as provided by law.

Section 4. If any section, clause, provision or part or portion of any section, clause or provision of this ordinance or the application thereof to any person or circumstance is held unconstitutional, such invalidity or unconstitutionality shall not affect the validity or application of any other section, clause, provision or part or portion of this ordinance.

Section 5. All ordinances or parts thereof in conflict herewith are hereby repealed.

PASSED AND APPROVED THIS 13th DAY OF MAY 2025.

CITY OF VALLEY, NEBRASKA

Cindy Grove, Mayor

ATTEST:

Christie Donnermeyer, City Clerk

RESOLUTION 2025-10

BE IT RESOLVED BY THE MAYOR AND CITY COUNCIL OF THE CITY OF VALLEY, DOUGLAS COUNTY, NEBRASKA:

WHEREAS, the City of Valley, Douglas County, Nebraska, proposes to enter into an Interlocal Cooperation Agreement with Douglas County Nebraska/Douglas County Libraries; and

WHEREAS, the Interlocal Cooperation Agreement with Douglas County Nebraska/Douglas County Libraries has been submitted; and

WHEREAS, the Valley City Council met in regular session on May 13, 2025 and reviewed said Agreement; and

NOW, THEREFORE, BE IT RESOLVED, the Valley City Council authorizes Mayor Cindy Grove to execute the Interlocal Cooperation Agreement with Douglas County Nebraska/Douglas County Libraries to provide for improving the service, operation, and use of public libraries, a copy of said Agreement is attached hereto and made a part hereof by reference.

PASSED AND APPROVED this 13th day of May, 2025.

CITY OF VALLEY, DOUGLAS COUNTY, NEBRASKA

Cindy Grove, Mayor

ATTEST:

Christie Donnermeyer, City Clerk

**INTERLOCAL COOPERATION AGREEMENT
BETWEEN
DOUGLAS COUNTY NEBRASKA/DOUGLAS COUNTY LIBRARIES
AND
CITY OF VALLEY**

THIS AGREEMENT is made and entered into on the dates indicated below, by and between Douglas County, Nebraska, a political subdivision of the State of Nebraska (hereinafter “County”), and the City of Valley, a municipal corporation and political subdivision of the State of Nebraska (hereinafter “City”).

WHEREAS, the *Interlocal Cooperation Act* of the State of Nebraska, being specifically Nebraska Revised Statutes Sections 13-801 through and including 13-807, enables separate political subdivisions of the State to cooperate on the basis of mutual advantage to provide for joint undertakings, services and facilities, in a manner and pursuant to forms of governmental organization that will best accord with the geographic, economic, population, and other factors influencing the needs and developments of local communities; and,

WHEREAS, said *Act* specifically allows that any powers, privileges, or authorities exercise by any single agency or political subdivision of the State may be exercised and enjoyed jointly with any other such subdivision and Nebraska Revised Statutes Section 51-201, et seq. specifically empowers cities and counties to own and operate libraries; and,

WHEREAS, acting through their governing bodies, County and City wish to cooperate on reaching an agreement on developing a cooperative with respect to equipment, facilities, personnel, service levels, and procedures to provide public library services to the citizens of the County and City.

IT IS, THEREFORE, AGREED BY AND BETWEEN THE PARTIES HERETO THAT:

In consideration of these mutual promises, in order to provide for improving the service, operation, and use of public libraries, County and City hereby agree to cooperate in the funding, planning, administration, and operation of public libraries as described below.

1. JOINT USE AND OTHER AGREEMENTS

The Library system provided for herein is to be a City/County Library and shall therefore be tax supported by both governments and available for the use of the citizens of the City and the unincorporated area of the County, without distinguishing between such citizens in available services or charges for the same. This Agreement supersedes all other Agreements between the Parties concerning libraries. Nothing in this Agreement is

intended to prevent, or otherwise affect, the County's ability to reach similar cooperative Library Agreements with any other city or village.

2. GENERAL PROVISIONS

a. PROVISION OF LIBRARY SERVICES

The City agrees to provide and the County agrees to accept, Library services for residents of unincorporated Douglas County. Except as otherwise hereinafter specifically set forth, such Library services shall only encompass functions and duties of the type coming within the jurisdiction of and customarily rendered by the Valley Public Library under the Charter of said City and the Statutes of the State of Nebraska.

b. DIRECTION OF EMPLOYEES AND WORK

The rendition of such service, the standard of performance, the direction of employees, and other matters incident to the performance of such services, and the control of personnel so employed, shall remain with the City. In the event of a dispute between the parties as to the extent of duties and functions to be rendered hereunder, the determination made by the Director of the Valley Public Library shall, within existing budgets, be final and conclusive as between the Parties hereto.

c. CITY SUPPLIES LABOR, EQUIPMENT, RESOURCE MATERIALS, FACILITIES AND SUPPLIES

For the purpose of performing said Library functions, City shall furnish and supply all necessary labor, supervision, equipment, resource materials, facilities, and supplies necessary to maintain the level of service to be rendered hereunder.

d. PERSONNEL ARE CITY EMPLOYEES

All persons employed in the performance of such services and functions pursuant to this Agreement for the County shall be City employees, and no County employees as such shall be taken over by said City, and no person employed hereunder shall have any County pension, civil service, or any status or right.

e. LIMITS ON COUNTY LIABILITY FOR SALARIES AND WAGES

County shall not be called on to assume any liability for the direct payment of any salaries, wages, or other compensation to any City personnel performing services hereunder for the County, or any liability other than that provided for in this Agreement.

f. LIMITS ON COUNTY LIABILITY FOR ACTS OF CITY EMPLOYEES

County, its officers and employees, shall not be deemed to assume any liability for intentional or negligent acts of the City or any officer or employee thereof.

3. TERM

This Agreement shall be for a term of seven (7) years beginning on July 1, 2025 (hereinafter "Effective Date", and ending on June 30, 2033, unless sooner terminated by a Party as provided herein. Either Party may terminate this Agreement for any reason upon providing written notice of its intent terminate the Agreement to the other party ninety (90) days prior to the date of cancellation, provided that no cancellation may be effective that is given after the City or County adopts its budget for the next fiscal year until the end of such next year.

4. FUNDING

The purpose of the Agreement is to increase cooperative effort between the Parties hereto in connection with the service, use, operation, and development of a public library system. At the effective date of this Agreement, County and City shall jointly fund the operational needs of the City-County Library System, provided for in this Agreement, which will serve, without discrimination, the citizens of all the area of the City and all of the unincorporated area within Douglas County.

The operational needs of such system are hereby agreed to be paid by the Parties with each Party's share being determined, as specified herein, in direct proportion to the population in the corporate limits of the City of Valley and in the remainder of the unincorporated County.

County agrees to provide by levy pursuant to Nebraska Revised Statute Section 51-201 an amount representing the City of Valley's per capita support multiplied by the number of citizens in unincorporated County, as specified below. The per capita support for the City is determined by the prior year's direct expenditures for Library services. This figure is calculated by the most recent MAPA estimates, or other agreed upon population numbers, for Valley's population and unincorporated County's population. The amount to be levied shall not exceed the statutory limit imposed by Nebraska Revised Statute Section 51-201.

The formula for distributing the Library Tax among all participating municipal libraries in Douglas County shall be as follows:

1. Proportion of each city's population to the total population of all participating cities;
2. Proportion of each city's assessed valuation to the assessed valuation of all participating cities;
3. Proportion of each Library's total circulation for preceding calendar year; and,
4. Proportion of each Library's current library cards issued to Douglas County Residents who live outside that city.

Each factor in this formula shall constitute twenty-five percent (25%) of the total fees paid by County for Library services.

The funds to be paid under this Agreement for Library services shall be paid by County in two installments on or before May 31 of each year and on or before September 30 of each year. Remittance shall be sent to the City of Valley, 203 N. Spruce Street, Valley, Ne 68064.

5. PERSONNEL

Library system staff of Librarians and other appropriate employees shall continue under the current system. The City, as provided by law, not the County, shall assume all of the liabilities of such employment so that no additional expenses result to the County.

6. ADMINISTRATION

No separate administrative entity is created to administer this Agreement and no joint financing or budget is established for the same, except to the extent provided above.

7. PERFORMANCE-ADMINISTRATION

The County and the City shall perform the covenants of this Agreement through their employees and independent contractors. This Agreement shall be administered primarily through the administrative offices of the County and City. This Agreement does not establish a separate legal entity to conduct a joint or cooperative undertaking, and, accordingly, construction and maintenance, staffing and other operations of, and upon, the real and personal property, used for the purposes described herein, shall be the person or persons placed in charge of such matters by the City. Except as specifically provided for herein, all property, real and personal, used in the performance of this Agreement, and existing at the end, shall be and remain that of the City as provided by law.

8. SERVICES STANDARDS

a. HOURS OF OPERATION

City shall maintain the same hours of operation for the use of all library facilities by residents of unincorporated County as it does for the use of the residents of the City.

b. ENHANCED SERVICES

City shall provide all services available to the residents of unincorporated County as they do for the residents of the City. Services in the library facilities are, in some measure, based on use, which will reflect the use by residents of the County unincorporated areas as well as that by residents of the City.

c. LIBRARY BOOK DELIVERY FOR RESIDENTS OF UNINCORPORATED DOUGLAS COUNTY

City shall provide efficient and cost-effective book delivery service for residents of unincorporated County in cooperation with, and by agreement with, the other libraries in the County.

9. MARKETING OF SERVICES

City shall market the availability of Library services to unincorporated residents of County in cooperation with, and by agreement with, the other libraries in the County.

10. MONITORING OF SERVICES

a. REPORTS

City shall provide an annual report detailing the following, as the Library's automation system allows:

1. Total County Card Holders by Location.
2. New Cards Issued to County Residents by Location.
3. Total Library Cards Issued to Area Residents by each Library Facility.
4. Total Checkouts by County Residents by Location.
5. Checkouts by Douglas County Residents at each Library Facility by Location.
6. Cost of Library Materials Checked Out by County Residents by Location.
7. Cost of Public Service Staff by Library Facility for Unincorporated County Card Holders.

11. NONDISCRIMINATION

The County and City agree that in accordance with the Nebraska Fair Employment Practice Act, Neb. Rev. Stat. § 48-1122, they will not discriminate against any employee or applicant for employment, to be employed in the performance of this Agreement, with respect to hire, tenure, terms, conditions, or privileges of employment because of the age, race, color, religion, sex, disability, or national origin of the employee or applicant, or similarly protected status of the employee or applicant. In addition, and with respect to all subcontractors, the Parties shall require compliance with Neb. Rev. Stat. § 48-1122. In the performance of this Agreement, all Parties shall not discriminate or permit discrimination in violation of any applicable federal or state laws or local ordinances.

12. DRUG FREE POLICY

Each Party assures the other that it has established and maintains a drug free workplace.

12.13. NEW EMPLOYEE WORK ELIGIBILITY STATUS

The Parties are required and hereby agree to use a federal immigration system to determine the work eligibility status of new employees physically performing services within the State of Nebraska. A federal immigration verification system means the electronic verification of the work authorization program authorized by the Illegal Immigration Reform and Immigrant Responsibility Act of 1996, 8 U.S.C. §1324a, known

as the E-Verify Program, or an equivalent federal program designated by the United State Department of Homeland Security or other federal agency authorized to verify the work eligibility status of a newly hired employee.

13.14. PUBLIC BENEFITS

With regard to Neb. Rev. Stat. §§4-108 – 113, neither Party is an individual or sole proprietorship. Therefore, neither Party is subject to the public benefits attestation and any related requirements of Neb. Rev. Stat. §§4-108 – 113.

14.15. INDEMNIFICATION

Each Party shall assume all risk of loss, indemnify the other against loss, and hold the other, its employees, agents, assignees, and legal representatives harmless from all liabilities, demands, claims, suits, losses, causes of action, fines, settlements or judgments and all expenses incident thereto, including but not limited to legal fees, for injuries to persons and for loss of, damage to, or destruction of property, arising out of or in connection with this Agreement and proximately caused by the indemnifying Party's negligent acts or omissions or those of its officers, employees or agents and assigns, for any losses caused by failure of the indemnifying Party to comply with terms and conditions of the Agreement, and for any losses caused by other parties which have entered into agreements with the indemnifying Party, provided that the Indemnified Party gives the Indemnifying Party prompt, written notice of any such claim, suit, demand or cause of action. The Indemnified Party shall cooperate in the defense or settlement negotiation of such claim, suit demand or cause of action. The provisions of this section shall survive expiration or termination of this Agreement. These Indemnification provisions are not intended to waive a Party's sovereign immunity. Each Party's liability is governed by and limited to the extent provided by the Nebraska Political Subdivision Tort Claims Act, or other applicable provisions of law.

15.16. AMENDMENTS

This Agreement may be modified only by written amendment, duly executed by authorized officials of the Parties. No alteration or variation of the terms and conditions of this Agreement shall be valid unless made in writing and signed by the Parties hereto. Every amendment shall specify the date on which its provisions shall be effective.

16.17. ASSIGNMENT AND DELEGATION

This Agreement is exclusive to the Parties and rights may not be assigned nor duties delegated by either Party except on prior written consent of the other. Any attempted assignment or delegation without such approval shall be void and shall constitute a material breach of contract. Any and all additional fees, charges, costs or expenses which result from an approved assignment or delegation shall be paid by the assigning/delegating Party. This Agreement shall be binding upon the Parties' successor and permitted assignees.

18. INSURANCE

All Parties shall maintain comprehensive General Liability insurance with limits of not less than One Million Dollars (\$1,000,000.00) for each person for any number of claims arising out of a single occurrence and Five Million Dollars (\$5,000,000.00) for all claims arising out of a single occurrence and shall provide proof thereof. All Parties agree to maintain throughout the term of this Agreement, and at their own expense, adequate statutory Nebraska workers' compensation insurance, and shall provide proof thereof. If a Party maintains higher limits than the minimum shown, the County requires and shall be entitled to the higher limits. Any available insurance proceeds in excess of the specified minimum limits of insurance and coverage shall be available to the County. Each Party's policies must contain a provision or endorsement that the coverage afforded will not be canceled, materially changed, non-renewed or aggregate limits exhausted until at least thirty (30) days prior written notice has been given. The policies required to be maintained shall be with companies rated A or better in the most current issue of A.M. Best's Insurance Ratings Guide. Insurers shall be licensed to do business in the state of Nebraska and domiciled in the USA. Parties shall provide a certificate of insurance to Douglas County Purchasing before work or services are undertaken pursuant to this Agreement and upon demand of County thereafter. All insurance documents and insurance notifications shall be sent to:

Douglas County Purchasing Agent
902 Civic Center, 1819 Farnam St.
Omaha NE 68183.

The County reserves the right to require a higher limit of insurance or additional coverages when the County determines that a higher limit or additional coverage is required to protect the County or the interests of the public. County does not represent in any way that the insurance specified herein, whether in scope of coverage or limits, is adequate or sufficient to protect Parties or their interests. Each Party is solely responsible to determine its need for and to procure additional coverage which may be needed in connection with this Agreement. The procuring of insurance as required by this Agreement shall not be construed to limit each Party's liability hereunder or to fulfill the indemnification provisions of this Agreement. Nothing contained in this clause or other clauses of this Agreement shall be construed to waive the Sovereign Immunity of the County.

Failure of the County to object to the form or content of the certificate or endorsement or to demand such proof as is required herein shall not constitute a waiver of any insurance requirement set forth herein. Failure of the County to demand such certificates of insurance, endorsements or other evidence of each Party's full compliance with these insurance requirements, or failure of the County to identify any deficiency in compliance from the evidence provided, shall not be construed as a waiver of each Party's obligation to obtain and maintain such insurance at all tiers.

IN WITNESS HEREOF, the Parties have executed this Agreement by and through the undersigned officers as of the Effective Date.

MEMORANDUM

TO: Valley City Council
FROM: Jeff Farnham
DATE: May 12, 2025
RE: Interlocal Cooperation Agreement with Douglas County

The purpose of this memorandum is to briefly summarize the provisions of the proposed Interlocal Cooperation Agreement with Douglas County, Nebraska, concerning the Valley City Library. The agreement is for a term of 7 years, commencing on July 1, 2025. I have attached a copy of the proposed agreement to this memo. The City and the County entered into similar agreements in 2011 and 2018.

The general purpose of the Agreement is to allow residents of Valley and Douglas County to use all libraries in Douglas County, including the City of Omaha's library.

The operation of the City/County Library System is jointly funded and under the terms of the Agreement, the City receives an amount each year from the County. Sami has provided a short memo, explaining this and giving some historical data as to the contributions received by the City, and the memo is attached.

The proposed Interlocal Agreement is essentially the same as has been used in past years, with the following revisions.

1. In paragraph 3, the beginning and ending dates of the agreement have been set forth.
2. In paragraph 4, the City's address has been added.
3. In paragraph 11, the last sentence has been added concerning compliance with Neb. Rev. Stat. Section 48-1122 (which provides that all contracts shall contain a similar non-discrimination provision) and that all parties shall not discriminate in violation of any applicable federal or state laws or local ordinances.
4. Paragraph 12 has been added indicating that each party shall maintain a drug-free workplace.

5. Paragraph 15 has been revised, but the nature of the paragraph as a mutual indemnification has not been changed.
6. Paragraph 17 has been added providing that the agreement is exclusive to the parties and neither party can assign the agreement without the approval of the other.
7. Paragraph 18 has been added setting forth the requirements of each party to maintain liability insurance of at least \$1,000,000.00 per person and \$5,000,000.00 per occurrence, provisions for certificates of insurance, notice of cancellation and other normal provisions. There is one provision in this paragraph, dealing with the County's ability to call for an increase in the amount of coverage, that I am still discussing with the Douglas County Attorney's office, but I anticipate that this issue will be resolved.

I find the proposed Interlocal Agreement, with the revisions discussed above, to be acceptable.

Memo



To: Valley City Council

From: Sami Stewart, Library Director

Date: 5/6/2025

Re: Douglas County Interlocal Agreement

Background on Interlocal Agreement:

The Douglas County Library interlocal agreement provides the ability to all residents in Douglas County to use any library in Douglas County, regardless of their city of residence. In exchange, the county provides a portion of their tax revenue to underwrite expenses. A version of this interlocal is already in effect and is due to be renewed. The interlocal agreement renews every 7 years. While the agreement itself is with the county, all public libraries in Douglas County are a part of this “system”. Libraries include Omaha, Bennington, Ralston, Waterloo, and Valley. VPL’s library card policy (per the Library Board of Trustees) allows all area residents, regardless of residency, to obtain and use a library card. The interlocal agreement provides the library with funds to recoup some of the costs for providing service to patrons living outside Valley city limits.

Benefits:

- Valley residents have access to Omaha Public Library’s broader collection of materials
- Provides income for VPL to serve those living in SIDs or other unincorporated areas
- Allows VPL to serve all residents in DC West school district, regardless of residency

Valley Public Library - Revenue Received from Douglas County per Library Interlocal Agreement

Accounting Date	Check Amount
26-Nov-2002	4,199.36
20-Jun-2003	3,309.50
09-Oct-2003	3,579.85
15-Dec-2004	4,052.21
24-Jun-2005	2,862.03
20-Dec-2005	2,978.42
22-Jun-2006	2,787.81
05-Oct-2006	2,827.38
21-Sep-2007	4,717.87
29-Oct-2007	8,252.63
20-Jun-2008	2,621.96
24-Dec-2008	3,436.25
01-Jun-2009	4,306.98
14-Oct-2009	4,148.52
07-Jun-2010	3,330.16
07-Jan-2011	3,255.29
19-May-2011	4,869.19
22-Nov-2011	4,748.80
01-Jun-2012	12,348.85
06-Mar-2013	10,525.17
17-May-2013	2,031.17
12-Nov-2013	2,574.59
29-May-2014	4,442.14
01-Apr-2015	3,758.12
26-Jun-2015	5,143.78
21-Dec-2015	3,842.16
21-Jun-2016	4,603.83
23-Feb-2017	2,643.28
20-Jun-2017	7,235.99
19-Oct-2017	5,591.09
04-Jun-2018	6,202.23
12-Dec-2018	4,487.58
20-Aug-2019	7,098.44
16-Oct-2019	4,863.60
25-Jun-2020	6,204.82
22-Oct-2020	3,957.27
24-Jun-2021	8,905.09
08-Nov-2021	6,579.79
16-Jun-2022	9,353.07
17-Feb-2023	6,859.97
16-May-2023	11,414.80
04-Oct-2023	10,278.05
08-May-2024	13,638.34
10-Oct-2024	10,142.73
Grand Total	245,010.16

RESOLUTION 2025-12

BE IT RESOLVED BY THE MAYOR AND CITY COUNCIL OF THE CITY OF VALLEY, DOUGLAS COUNTY, NEBRASKA:

WHEREAS, the City of Valley, Douglas County, Nebraska, proposes to enter into a Douglas Sarpy Mutual Aid Interlocal Cooperation Agreement between the law enforcement Agencies of City of Bellevue in Sarpy County, Nebraska (hereinafter “BVPD”); City of La Vista in Sarpy County, Nebraska (hereinafter “LVPD”); City of Omaha in Douglas County, Nebraska (hereinafter “OPD”); City of Papillion in Sarpy County, Nebraska (hereinafter “PPD”) ; City of Ralston in Douglas County, Nebraska (hereinafter “RPD”); City of Valley in Douglas County, Nebraska (hereinafter “VPD”); City of Waterloo in Douglas County, Nebraska (hereinafter “WPD”); City of Bennington in Douglas County, Nebraska (hereinafter “BPD”); Sarpy County, Nebraska (hereinafter “SCSO”); Village of Boys Town in Douglas County, Nebraska (hereinafter “BTPD”); and Douglas County, Nebraska (hereinafter “DCSO”); and

WHEREAS, the Douglas Sarpy Mutual Aid Interlocal Cooperation Agreement has been submitted; and

WHEREAS, the Valley City Council met in regular session on May 13, 2025 and reviewed said Agreement; and

NOW, THEREFORE, BE IT RESOLVED, the Valley City Council authorizes Mayor Cindy Grove to execute the Douglas Sarpy Mutual Aid Interlocal Cooperation Agreement between the law enforcement Agencies of City of Bellevue in Sarpy County, Nebraska (hereinafter “BVPD”); City of La Vista in Sarpy County, Nebraska (hereinafter “LVPD”); City of Omaha in Douglas County, Nebraska (hereinafter “OPD”); City of Papillion in Sarpy County, Nebraska (hereinafter “PPD”) ; City of Ralston in Douglas County, Nebraska (hereinafter “RPD”); City of Valley in Douglas County, Nebraska (hereinafter “VPD”); City of Waterloo in Douglas County, Nebraska (hereinafter “WPD”); City of Bennington in Douglas County, Nebraska (hereinafter “BPD”); Sarpy County, Nebraska (hereinafter “SCSO”); Village of Boys Town in Douglas County, Nebraska (hereinafter “BTPD”); and Douglas County, Nebraska (hereinafter “DCSO”) to empower law enforcement officers (hereinafter "Officers") of each of the Cooperating Agencies to exercise extraterritorial law enforcement authority, including arrest and enforcement under the laws of this state and legal ordinances of each Cooperating Agency, within the jurisdiction of each of the other Cooperating Agencies.

PASSED AND APPROVED this 13th day of May, 2025.

CITY OF VALLEY, DOUGLAS COUNTY, NEBRASKA

Cindy Grove, Mayor

ATTEST:

Christie Donnermeyer, City Clerk

DOUGLAS SARPY MUTUAL AID
INTERLOCAL COOPERATION AGREEMENT

THIS AGREEMENT (hereinafter "Agreement" or "Douglas Sarpy Mutual Aid Interlocal") is entered into by and between the law enforcement Agencies of City of Bellevue in Sarpy County, Nebraska (hereinafter "BVPD"); City of La Vista in Sarpy County, Nebraska (hereinafter "LVDPD"); City of Omaha in Douglas County, Nebraska (hereinafter "OPD"); City of Papillion in Sarpy County, Nebraska (hereinafter "PPD"); City of Ralston in Douglas County, Nebraska (hereinafter "RPD"); City of Valley in Douglas County, Nebraska (hereinafter "VPD"); City of Waterloo in Douglas County, Nebraska (hereinafter "WPD"); City of Bennington in Douglas County, Nebraska (hereinafter "BPD"); Sarpy County, Nebraska (hereinafter "SCSO"); Village of Boys Town in Douglas County, Nebraska (hereinafter "BTPD"); and Douglas County, Nebraska (hereinafter "DCSO"), herein collectively referred to as "Cooperating Agencies" or "Agencies."

WHEREAS, the Cooperating Agencies wish to implement to the extent hereafter provided, the provisions of Neb. Rev. Stat. Sec. 29-215 (hereinafter "Sec. 29-215"), so as to empower law enforcement officers (hereinafter "Officers") of each of the Cooperating Agencies to exercise extraterritorial law enforcement authority, including arrest and enforcement under the laws of this state and legal ordinances of each Cooperating Agency, within the jurisdiction of each of the other Cooperating Agencies; and,

WHEREAS, the Cooperating Agencies wish to provide for personnel backup and such other assistance as any of the Agencies may require in time of emergency or other time of need; and,

WHEREAS, the Cooperating Agencies have common goals, staffing needs, training needs and other needs in common in the area of law enforcement, and the joint cooperation contemplated by this Agreement will allow the Agencies each to provide improved law enforcement services at less cost; and,

WHEREAS, each of the Cooperating Agencies, as among themselves, wish to improve law enforcement services and implement, to the extent herein provided, the authority given by Sec. 29-215 to law enforcement officers of each of the Agencies hereto to enforce the laws of this state and legal ordinances of Cooperating Agencies; and,

WHEREAS, the Cooperating Agencies wish to formalize their understanding pursuant to the Interlocal Cooperation Act of the State of Nebraska, Neb. Rev. Stat. Sec. 13-801 *et seq.*, as amended (herein "Interlocal Cooperation Act").

NOW, THEREFORE, IT IS AGREED AS FOLLOWS:

1. Definitions: As used herein the following terms shall have the following meanings:
 - A. "Agency of Primary Jurisdiction" shall mean the Agency responsible for territorial limits of the geographic area within which an arrest is being made, warrant served or other law enforcement activity is occurring.
 - B. "Cooperating Agencies" or "Agencies" shall mean the Agencies signatory hereto, and "Agency" shall mean any one of the Agencies.

- C. "Host Agency" shall mean an Agency of Primary Jurisdiction other than an Officer's own Agency of regular employment.
 - D. "Officer" shall mean a duly sworn full-time or part-time paid law enforcement officer in the employ of a Cooperating Agency.
 - E. "Officer's Primary Jurisdiction" shall mean the geographic area within the territorial limits (corporate limits) of the Agency which regularly employs the Officer.
2. Authority. The authority for the Cooperating Agencies entering into this Agreement is that authority granted by law, including the general powers of the Agencies, the Nebraska Interlocal Cooperation Act, and the authority granted under Sec. 29-215.
3. Purpose. The purpose of this Agreement is to authorize the Officers of each Cooperating Agency to provide law enforcement services outside the limits of their respective primary jurisdictions as authorized by Subsection (2)(d) of Sec. 29-215, and to improve law enforcement in each of the Cooperating Agencies and throughout the eleven agency areas through fuller authority and utilization of Officers, through joint training of Officers, sharing of equipment, mutual assistance and the ability to staff Officers based upon the availability of assistance in time of need and to generally enhance law enforcement capacities of the Agencies at a reduced cost to the Agencies.
4. Certain Authority to Act Beyond Primary Jurisdiction Independently Vested by Sec. 29-215. The Agencies recognize that by the provisions of Sec. 29-215, their Officers are given power and authority to act beyond the Officer's Primary Jurisdiction, independent and apart from this agreement in the following situations:
- A. If in a fresh attempt to apprehend a person suspected of committing a felony, Officers may follow such person into any jurisdiction in this state and there arrest and detain such person and return such person to the Officer's Primary Jurisdiction. (Sec. (2)(a) Sec. 29-215).
 - B. If in a fresh attempt to apprehend a person suspected of committing a misdemeanor or a traffic infraction, Officers may follow such person anywhere in an area within twenty-five miles of the boundaries of the Officer's Primary Jurisdiction and there arrest and detain such person and return such person to the apprehending Officer's Primary Jurisdiction. (Sec. (2)(b), Sec. 29-215).
 - C. The Officers shall have such enforcement and arrest and detention authority when responding to a call in which a local, state or federal law enforcement officer is in need of assistance, need of assistance being defined to mean:
 - 1). a law enforcement officer whose life is in danger; or
 - 2). a law enforcement officer who needs assistance in making an arrest

and the suspect (a) will not be apprehended unless immediately arrested, (b) may cause injury to himself or herself or others or damage to property unless immediately arrested, or (c) may destroy or conceal evidence of the commission of a crime. (Sec. (2)(c) Sec. 29-215).

- D. When probable cause exists to believe that a person is operating or in actual physical control of any motor vehicle, motorboat, personal watercraft, or aircraft while under the influence of alcoholic liquor or of any drug or otherwise in violation of section 28-1465, 28-1466, 28-1472, 37-1254.01, 37-1254.02, 60-4,163, 60-4,164, 60-6,196, 60-6,197, 60-6,211.01. or 60-6,211.02, the law enforcement officer has the power and authority to do any of the following or a combination thereof:
- 1) Transport such a person to a facility outside of the law enforcement officer's primary jurisdiction for appropriate chemical testing of the person;
 - 2) Administer outside of the law enforcement officer's primary jurisdiction any post-arrest test advisement to the person; or
 - 3) With respect to such person, perform any other procedures or functions outside of the law enforcement officer's primary jurisdiction which are directly and solely related to enforcing the laws that concern a person operating or being in the actual physical control of any motor vehicle, motorboat, personal watercraft, or aircraft while under the influence of alcoholic liquor or of any other drug or otherwise in violation of section 28-1465, 28-1466, 28-1472, 37-1254.01, 37-1254.02, 60-4,163, 60-4,164, 60-6,196, 60-6,197, 60-6,211.01, or 60-6,211.02. (Sec. (3)(a-c) Sec. 29-215).

This Agreement is not intended nor shall it be construed to in any way limit the power and authority granted by the foregoing provisions of Sec. 29-215. Each of the Cooperating Agencies may individually impose in respect to its own Officers such conditions or limitations on the exercise of the foregoing powers by their own Officers as each such Agency may choose not inconsistent with the terms hereof.

5. Following Suspects Across Jurisdictional Lines. The authority to follow suspects across jurisdictional lines is based upon direct legislative grant of power as contained in Subsections (2)(a) and (2)(b) of Sec. 29-215 and is not derived from nor does it flow from consent of the Cooperating Agencies to the exercise of such authority or the provisions of this Agreement.

In respect to following suspects across jurisdictional lines and related action taken by Officers while within the jurisdiction of a Host Agency, the Host Agency shall not be liable for death,

bodily injury, property damage or personal injury including false arrest, caused by or resulting from such following or related action, by such non-host Agency Officers and the Agency which employs the Officer(s) doing the following agrees, subject to the liability limits of the Political Subdivision Tort Claims Act, to indemnify and save harmless the Host Agency from loss or liability caused by:

- A. the negligence of such non-host Agency Officers doing the following; or
- B. imposition of liability under Neb. Rev. Stat. Section 13-911, as changed or amended from time to time, resulting from actions by such non-host Agency Officers doing the following or pursuing of a suspect in a Host Agency.

6. Additional Authority Granted Pursuant to Interlocal Cooperation Act. Subject to the limitations hereinafter set forth in this Agreement, the Officers of each of the Agencies while in a Host Agency shall have full law enforcement authority, including the authority to arrest and detain, in the following circumstances:

- A. The commission of a felony witnessed by the Officer.
- B. The Officer is a witness to a criminal act or threatened criminal act, or a traffic infraction, whether or not constituting felonious conduct, where non-arrest poses immediate danger or threat to life or safety to the Officer or any other person or persons.
- C. While engaged in or providing services under a mutual assistance request from a Host Agency.
- D. While serving regular shift duty or other period of duty within a Host Agency that has requested Officer coverage or backup for such period of time.
- E. While participating in investigative activity or other cooperative law enforcement activity authorized by this Agreement.

7. Host Agency Prior Consent to Exercise Arrest Authority. Officers not in the Officer's Primary Jurisdiction and while in a Host Agency may make arrests in the following situations without the prior consent of the Host Agency:

- A. In the case of commission of a felony witnessed by the Officer; and
- B. In the case of any criminal act, or threatened criminal act, or a traffic infraction, whether or not constituting felonious conduct, where non-arrest poses immediate danger or threat to life or safety to the Officer or any other person or persons.
- C. when authorized by any provision of Sec. 29-215.

Should such an arrest without prior consent occur, the arrest shall be reported to a supervisor or senior shift officer of the Host Agency in the Jurisdiction for which the arrest occurred as soon as is reasonably possible.

Except for arrests falling within the scope of Paragraph 7(a) and 7(b) above, an Officer, prior to making an arrest in a Host Agency, when not accompanied by an Officer of the Host Agency, shall request the consent of the Host Agency prior to making the arrest. A supervisor or senior shift officer of the Host Agency on duty at the time shall advise as to whether the Host Agency consents to or is withholding consent to the intended arrest, by the Officer at the scene. When feasible, the Host Agency shall dispatch one of its own Officers to the scene to make the arrest. If the Officer at the scene is advised that an Officer from the Host Agency, or other law enforcement officer dispatched at the direction of the Host Agency, has been dispatched to the scene, the Officer at the scene shall, if time and circumstances permit, delay arrest until such Host Agency Officer, or highway patrol officer arrives to make the arrest or to assist therein.

8. Mutual Assistance. Each of the Cooperating Agencies agrees to render law enforcement assistance to each of the other Cooperating Agencies when such assistance is of an emergency nature or one of a non-emergency nature requiring backup or additional Officer force beyond that then available to the requesting Agency in accordance with the following provisions:
 - A. Requests for Assistance.
 - 1) Emergency Situations. Requests by an Agency for assistance in emergency situations may be made by any of the following:
 - a. the Mayor or Acting Mayor;
 - b. Agency Administrator or Acting Agency Administrator;
 - c. Agency head or Acting Agency head; or
 - d. Supervisor or Senior Shift Officer of the Agency requesting assistance.
 - e. In situations posing any immediate threat to the life or safety of an Officer or other person, any Officer may himself or herself make such request.
 - 2) Non-Emergency Situations. Requests for assistance in non-emergency situations may be made only by the requesting Agency's Mayor, Agency Administrator, Agency head or other person within the law enforcement department of command rank and who is expressly authorized by the requesting Agency to request aid in non-emergency situations.
 - B. No Liability for Failure to Respond. It is understood and agreed by all of the Cooperating Agencies that assistance is not assured or guaranteed to any

Agency. Nor is there any understanding that all, or any, requests for assistance will be met. It is expressly agreed by and between all Agencies that any Agency to which a request is made, or which shall otherwise have knowledge of need of assistance in another Agency, shall have no liability whatsoever to the requesting Agency or any other Agency signatory hereto or to the Officers or employees of any Agency or to any third person whomsoever for failure for whatever reason to respond to, or delay in responding to, a call for assistance or for failure to communicate such call or any failure or delay. Each Agency covenants not to sue and agrees to save harmless each of the other Agencies for any claim or action based, in any manner, on a failure to respond in or to a request for assistance under this Agreement.

- C. Radio Communication. Cooperating agencies will, through separate interlocal agreement, ensure that a system is maintained that facilitates radio communication between all cooperating agencies.
 - D. Command at Scene. The Agency requesting assistance shall provide command at the scene for which assistance is requested.
 - E. Procedures. The Cooperating Agencies may develop and effectuate mutually agreed upon written procedures consistent with the mutual assistance provisions hereof.
9. Training. Each Cooperating Agency is responsible for the training of its personnel. The Cooperating Agencies may participate in joint training as agreed upon by the Cooperating Agencies.
10. Search Warrants. Unless otherwise agreed to by a Host Agency, search warrants to be served or acted upon in Host Agency jurisdiction shall have named thereon and shall be served by an Officer of the Host Agency. An Officer of the requesting Agency may, but need not be, named on the warrant or other issuance in addition to an Officer of the Host Agency. Each Agency shall treat requests for service of warrants from other Agencies in the most expeditious manner reasonably possible under the circumstances.
11. Equipment. Cooperating Agencies shall be solely responsible for the maintenance of all equipment provided and utilized by its law enforcement officers, and shall not be required to provide any equipment, maintenance, or repair to any equipment used by those law enforcement officers providing assistance pursuant to this Agreement and who are employed by the other Cooperating Agencies.

Any supplies, equipment, vehicles or other personal property or other real property, which is utilized in the performance of the duties and obligations created under this Agreement, shall remain at all times the property and the sole responsibility of each such jurisdiction and shall not be the obligation or responsibility of the other Cooperating Agencies.

12. Investigation. Each Cooperating Agency shall assist other Agencies requesting assistance in the investigation of persons within the limits of primary jurisdiction of the cooperating Agency who are suspected by such other Agency of committing or believed to have information concerning crimes or criminal activity occurring in such other Agency. When reasonably possible, a Host Agency shall provide an Officer to personally accompany the Officer or Officers of another Agency during their investigation within the Host Agency.
13. Financing. Each Cooperating Agency shall be responsible for all compensation and remuneration of its own employees and shall pay all required payroll, wages, taxes, and benefits as provided by law. Each Cooperating Agency shall also be responsible for the costs of equipment provided and utilized by its law enforcement officers in accordance with Paragraph 11 of this agreement.
14. Officers Remain Employees of Own Agency. An Officer, while serving outside the Officer's Primary Jurisdiction shall at all times be considered and held as serving in the regular line of duty of the Agency which employs the Officer as fully as if the Officer were serving within the limits of the Officer's Primary Jurisdiction.
15. Disciplinary Procedures. Disciplinary action arising out of an Officer's conduct, actions, or omissions, whether occurring within or outside the Officer's Primary Jurisdiction, shall be handled by the Agency which employs the Officer, that is, the Officer's Primary Jurisdiction.
16. Rules and Regulations. The Agencies recognize that the duties, work, skills and working conditions may differ between Agencies. While serving outside their own Agency, Officers serving pursuant to this Agreement shall conduct themselves in accordance with the policies and procedures of the Officer's Primary Jurisdiction, except as may otherwise be agreed to by such Officer's Agency of Primary Jurisdiction and the Host Agency in which the service is performed.
17. Liability Insurance. Each of the Cooperating Agencies agrees to be self-insured or to carry liability insurance written on an "occurrence" basis (as distinguished from "claims made" basis) covering all law enforcement personnel assigned by each Agency under this Agreement and insuring against liability for bodily injury, personal injury (including false arrest) and property damage, in an amount not less than the maximum liability of Agencies of the appropriate class for acts of its law enforcement personnel as from time to time established by the Legislature, said limit at date hereof being \$1,000,000 per person and \$5,000,000 per occurrence, as prescribed by Neb. Rev. Stat. Section 13-1802. Each Agency's insurance or self-insurance shall cover acts and omissions of its Officers while performing services under this Agreement. These Insurance provisions are not intended to waive an Agency's sovereign immunity. Each Agency's liability is governed by and limited to the extent provided by the Nebraska Political Subdivision Tort Claims Act, or other applicable provisions of law.
18. Public Information. To the extent that specific case information relating to a mutual

effort with other law enforcement agencies is made public, each agency shall be responsible for responding to the request to determine which of the reports that it generated may be made available to the public. No participating agency shall release any document generated by another agency without permission unless release is required by a court order.

19. No Agency Relationship Created. This Agreement merely creates the framework for cooperation among the Cooperating Agencies for the purposes hereof, and there is no agency or instrumentality and no agency relationship created hereby between the Agencies or between any Agency's employee and any other Agency. The cooperative activity hereby established does not constitute an independent agency or employer. This is a cooperative undertaking between the Agencies and Officers while performing any services under this Agreement shall at times and for all purposes remain employees exclusively of the law enforcement department of the Agency which encompasses the Officer's Primary Jurisdiction and shall for no purpose be deemed to be an employee of any other Agency.
20. No Separate Entity. This Agreement does not create a separate legal entity under the Interlocal Cooperation Act. For purposes of that Act, this Agreement shall be administered jointly by the Agencies. In cases of disagreement on the administration of this Agreement, the heads of each agency will be responsible for mediating such disagreements. This Agreement does not contemplate acquiring, holding or disposing of joint property nor does it contemplate the levying or collecting of any tax.
21. Term of Agreement. This Agreement shall be effective on the first day of the calendar month next following the completion of implementing action by all eleven Agencies as required by Paragraph 22(b) of this Agreement hereof and shall continue in full force and effect for a period of five (5) years thereafter unless terminated earlier by ordinance or resolution of the governing body of any Agency, the effective date of termination shall not be less than thirty (30) days following such terminating Agency's written notice to all other Agencies. The termination of this Agreement by one Agency does not terminate the Agreement between the remaining Agencies, which shall remain in full force and effect. A review of the Agreement may occur upon request of any of the Cooperating Agencies.
22. Miscellaneous.
 - A. Other Agreements. The cooperative program hereby established is cumulative to and not in lieu of specific agreements heretofore or hereafter entered into between any of the Cooperating Agencies in respect to other aspects of public safety. In the event of conflict or when resolving any ambiguities, this Douglas Sarpy Mutual Aid Interlocal takes precedence over any other agreement.
 - B. Implementing Action. Prior to the operative date of this Agreement, each Agency shall take formal action by ordinance

or resolution of its governing body approving this Interlocal Cooperation Agreement. Each Agency shall furnish the other Agencies executed copies of such authorizing action.

23. Mutual Non-Discrimination Clause. The Agencies agree that in accordance with the Nebraska Fair Employment Practice Act, Neb. Rev. Stat. §48-1122, and 42 USCS 12101 *et seq.* Agencies and their subcontractors will not discriminate against any employee or applicant for employment, to be employed in the performance of this Agreement, with respect to hire, tenure, terms, conditions, or privileges of employment because of the age, race, color, religion, sex, disability, political or religious opinions or affiliations, or national origin of the employee or applicant. Agencies and their subcontractors shall not, in the performance of this Agreement, discriminate or permit discrimination in violation of any applicable federal or state laws or local ordinances.
24. Multiple Counterparts. This agreement, involving numerous Agencies, may be executed in multiple counterparts each of which may bear the signatures of less than all of the Agencies hereto, and it shall be in full force and effect even if so executed
25. General Provisions

A. Independent Contractors

It is agreed that nothing contained herein is intended or should be construed in any manner as creating or establishing a partnership or joint venture between the Agencies. Any and all acts that any Agency or its personnel, employees, agents, or contractors, perform pursuant to the terms of this Agreement shall be undertaken as independent contractors and not as employees of the other. The Agencies shall, except as provided herein, act in their individual capacities and not as agents, employees, partners, joint ventures or associates of the other. An employee or agent of one shall not be deemed or construed to be the employee or agent of the others for any purpose whatsoever. No Agency, nor its personnel, employees, agents, or contractors shall be entitled to any benefits of the others. The Agencies shall not provide any insurance coverage to the others or their employees including, but not limited to, workers' compensation insurance. Each Agency shall pay all wages, salaries and other amounts due its employees and shall be responsible for all reports, obligations, and payments pertaining to social security taxation, income tax withholding, workers' compensation, unemployment compensation, group insurance coverage, collective bargaining agreements or any other such similar matters. Any and all claims that may or might arise under the Workers' Compensation Act of the State of Nebraska on behalf of said personnel or other persons while so engaged, and any and all claims whatsoever on behalf of any such person or personnel arising out of employment or alleged employment, including without limitation claims of discrimination against an Agency its officers, employees, agents, or contractors shall in no way be the responsibility of that Agency. No Agency shall have any authority to bind the others by or with any contract or agreement, nor to impose any

liability upon the others. All acts and contracts of each shall be in its own name and not in the name of the others, unless otherwise provided herein.

B. Release and Indemnity

Each Agency shall assume all risk of loss, indemnify the others against loss, and hold the others, its employees, agents, assignees, and legal representatives harmless from all liabilities, demands, claims, suits, losses, causes of action, fines, settlements or judgments and all expenses incident thereto, including but not limited to legal fees, for injuries to persons and for loss of, damage to, or destruction of property, arising out of or in connection with this Agreement and proximately caused by the indemnifying Agency's negligent acts or omissions or those of its officers, employees or agents, and assigns, for any losses caused by failure of the indemnifying Agency to comply with terms and conditions of the Agreement, and for any losses caused by other Agencies which have entered into agreements with the indemnifying Agency, provided that the Indemnified Agency gives the Indemnifying Agency prompt, written notice of any such claim, suit, demand or cause of action. The Indemnified Agency shall cooperate in the defense or settlement negotiation of such claim, suit, demand or cause of action. The provisions of this section shall survive expiration or termination of this Agreement. These Indemnification provisions are not intended to waive an Agency's sovereign immunity. Each Agency's liability is governed by and limited to the extent provided by the Nebraska Political Subdivision Tort Claims Act, or other applicable provisions of law.

C. Drug Free Policy

Each Agency assures the others that it has established and maintains a drug free workplace policy.

D. New Employee Work Eligibility Status

The Agencies shall use a federal immigration verification system to determine the work eligibility status of new employees physically performing services within the State of Nebraska. A federal immigration verification system means the electronic verification of the work authorization program authorized by the Illegal Immigration Reform and Immigrant Responsibility Act of 1996, 8 U.S.C. §1324a, known as the E-Verify Program, or an equivalent federal program designated by the United States Department of Homeland Security or other federal agency authorized to verify the work eligibility status of a newly hired employee.

E. Public Benefits

With regard to Neb. Rev. Stat. §§4-108 - 113, no Agency is an individual or sole proprietorship. Therefore, no Agency is subject to the public benefits attestation and related requirements of Neb. Rev. Stat. §§4-108 – 113.

F. Unavailability of Funding

Due to possible future reductions in Municipal, County, State and/or Federal appropriations, Agencies cannot guarantee the continued availability of funding for this

Agreement, notwithstanding the consideration stated in this Agreement. In the event funds to finance this Agreement become unavailable either in full or in part due to such reduction in appropriations, one Agency may terminate the Agreement or reduce the consideration upon notice in writing to the other Agencies. The notice shall be delivered by certified mail, return receipt requested, or in person with proof of delivery. Each Agency shall be the final authority as to the availability of their funds. The effective date of such Agreement termination or reduction in consideration shall be specified in the notice as the date of service of the notice or the actual effective date of the County, State and/or Federal funding reduction, whichever is later. Provided, that reduction shall not apply to payments made for services satisfactorily completed prior to the effective date. In the event of a reduction of consideration, any Agency may cancel this Agreement as of the effective date of the proposed reduction upon the provision of advance written notice to any Agency.

G. Conflict of Interest

In the performance of this Agreement, Agencies will avoid all conflicts of interests or appearances of conflict of interest. Agencies will report any conflict of interest immediately to each other. Agencies assure each other that no Agency employee will have a financial or personal interest in this Agreement. Agencies have not and will not provide any money or other benefit of any kind to any other Agency employee in the procuring of, facilitation of, or execution of this Agreement.

H Amendments

This Agreement may be modified only by written amendment, duly executed by authorized officials of the Agencies. No alteration or variation of the terms and conditions of this Agreement shall be valid unless made in writing and signed by the Agencies hereto. Every amendment shall specify the date on which its provisions shall be effective.

I. Choice of Law

The Agencies to this Agreement shall conform to all existing and applicable city ordinances, resolutions, state and local laws, federal laws, and all existing and applicable rules and regulations. This Agreement shall be governed by and construed in accordance with the laws of the State of Nebraska without giving effect to any choice or conflict of law provision that would cause the application of laws of any jurisdiction other than those of the State of Nebraska. In addition, all claims relating to or arising out of this contract, or the breach thereof, whether based in contract, tort or otherwise, shall likewise be governed by the laws of the State of Nebraska without giving effect to any choice or conflict of law provision as previously provided here. Venue for any non-federal legal proceeding under this Agreement shall be in the State of Nebraska, District Court of Douglas County and for any federal legal proceeding in the United States District Court for the State of Nebraska located in Omaha, Nebraska.

J. Assignment and Delegation

This Agreement is exclusive to the Agencies and rights may not be assigned nor duties

delegated by any Agency except on prior written consent of the other Agencies. Any attempted assignment or delegation without such approval shall be void and shall constitute a material breach of contract. Any and all additional fees, charges, costs or expenses, which result from an approved assignment or delegation, shall be paid by the assigning/delegating Agency. Shall such approval to assign or delegate be granted, all covenants, stipulations, and agreements herein shall inure to the benefit of the Agencies and extend to and bind the legal representatives, successors, and assigns of the Agencies.

K. Joint Work Product

This Agreement is the joint work product of the Agencies; accordingly, in the event of any ambiguity, no presumption shall be imposed against or in favor of any Agency by reason of document preparation.

L. Entire Agreement

This Agreement contains the entire agreement of the Agencies. The provisions of this Agreement may not be explained, supplemented, or qualified through evidence of trade usage or prior course of dealings. No representations were made or relied upon by any Agency other than those that are expressly set forth herein. No agent, employee or other representative of any Agency is empowered to alter any of the terms hereof except as provided herein.

M. Incorporation of Recitals

The recitals set forth above are, by this reference, hereby incorporated into and deemed part of this Agreement.

N. No Third Party Rights

This Agreement is executed for the benefit of the named Agencies only. This Agreement is not intended to, nor shall it provide rights to any third party, excluding any assignment as provided herein, with any remedy, claim, liability, reimbursement, cause of action or other right or privilege; except that this Agreement's indemnification provision shall also inure to the benefit of an Agency's employees, officers and agents.

O. Authorized Representatives and Notice

Except for any notice required under applicable law to be given in another manner, any notice or communication required or permitted hereunder shall be given in further consideration of the mutual covenants herein contained. The Agencies hereto expressly agree that for purposes of notice, during the term of this Agreement and for the period of any applicable statute of limitations thereafter, the head of each agency shall be the authorized representative of the Agencies.

Notice shall be in writing and shall be effective upon receipt. Delivery may be by hand, in which case a signed receipt shall be obtained, or by United States mail, registered or certified, return receipt requested, by facsimile with a signed return facsimile acknowledging receipt or via electronic mail with an acknowledging receipt.

P. Headings

The section headings appearing in this Agreement are inserted only as a matter of convenience, and in no way define or limit the scope of any section.

METROPOLITAN AREA PLANNING AGENCY
MEMORANDUM OF UNDERSTANDING

A Memorandum of Understanding (MOU) by the City of Valley regarding the Metropolitan Area Planning Agency (MAPA) Comprehensive Safety Action Plan (CSAP) and the commitment to jurisdiction-level actions to reduce traffic fatalities and serious injuries to zero by the year 2040.

One death on our streets is one too many; between 2018 and 2022, there were 268 traffic fatalities and 2,266 serious injuries in the MAPA region. This MOU aims to inform communities within the MAPA region of resources available to them through the development of the CSAP and ensure commitment by The City of Valley to the priorities of the CSAP.

The CSAP is a comprehensive, data-driven document that states the aforementioned overarching goal for the region, informs about the U.S. DOT's Safe System Approach, emphasizes the current state of safety through regional trends, safety focus areas, and the High Priority Network, and provides a Vision Zero Toolbox, prioritized safety projects, recommendations, and safety metrics that communities can measure their progress in achieving zero traffic fatalities and serious injuries by 2040.

Through the Safe System Approach and the Comprehensive Safety Action Plan, communities within the MAPA region can create safer streets and roads for all; for this reason, this MOU states that:

The City of Valley should adopt the Safe System Approach as a comprehensive and holistic approach to eliminating traffic fatalities and severe injuries and should use the Safe System Approach when evaluating projects, conducting traffic studies, and implementing transportation improvements.

The City of Valley should acknowledge and incorporate the CSAP into their approach, plans, design, construction, enforcement, and support of regional safety efforts. Additionally, recommendations and goals from the CSAP should be incorporated, where applicable, into comprehensive and master plans.

The City of Valley should coordinate with MAPA and the Nebraska Department of Transportation to share relevant transportation and safety data.

The City of Valley should use the High Priority Network tool ([MAPA SS4A App](#)) in assessing safety concerns.

The City of Valley should utilize the Vision Zero Toolbox, which is contained within the CSAP, to quickly implement vetted infrastructure, behavioral, and enforcement countermeasures to create safer roads for all users.

The City of Valley should work to align funding and prioritize projects identified in the CSAP to address systemic safety concerns, such as within their Capital Improvements Program.

The City of Valley should work to adopt and implement applicable recommendations defined within the CSAP.

This Memorandum of Understanding shall take effect immediately upon its adoption.

Signed: _____ Date: _____

Printed: _____

MAPA's Safety Action Plan: A Regional Commitment to Saving Lives

MAPA's Regional **Comprehensive Safety Action Plan** is a **collaborative, data-driven** roadmap to eliminate traffic fatalities and serious injuries by 2040. Developed with input from technical experts, community members, and regional stakeholders, the plan identifies high-risk areas through predictive and systemic analysis, recommends targeted safety solutions, and provides a clear framework for implementation. It emphasizes leadership, cross-jurisdictional coordination, policy innovation, and data transparency.

What's in the Plan?



Data-driven overview of regional crash trends and risk factors.



"Vision Zero Toolbox" of **Proven Safety Countermeasures** with guidance on where and how to apply them including effectiveness and cost.



High Priority Safety Projects - 597 intersections and 451 miles of roadway - that represent strong candidates for future grant funding.



Actionable policy recommendations and strategies to guide regional safety planning efforts and support a long term vision of zero traffic fatalities and serious injuries.

Regional Safety Requires Regional Commitment

Signing this MOU demonstrates;

- Commitment to the Safe System Approach
- Alignment with CSAP goals
- Commitment to cross-jurisdictional coordination
- Formal adoption of the CSAP as your jurisdiction's Safety Action Plan*

*Formal adoption makes your community eligible for future safety-related grant funding to help implement identified projects.

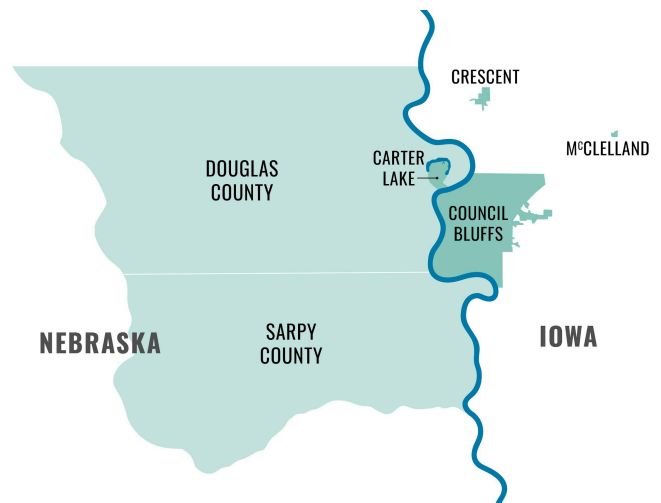

Zero Traffic Fatalities by 2040 Starts with You

MAPA is committed to supporting local partners like you in turning this plan into action, and we look forward to your leadership in advancing safer streets across our region.

VALLEY, NE

Population: 1,510
(2020)

Area: 6.1 sq. mi.

of KSI crashes: 9
(2018-2022)

of VRU crashes: 2
(2018-2022)

Top Focus Areas:

Overrepresentation of KSI crashes compared to all crashes within Valley

Arterials (11.3x)

Motorcyclists (6.2x)

Occupant Protection (1.8x)

Pedestrians & Bicyclists (6.2x)

Speed (2.1x)

RECOMMENDATIONS

Upon Plan Adoption/Ongoing

LC-01: Adopt a Vision Zero Resolution

LC-07: Safety Specific Funding

SR-19: Systemic Signal Improvement Standards

Short-Term

LC-03: Public-Private Partnership

LC-10: Local CIP Project Identification and Prioritization

SR-01: Safety Lighting Action Plan

SR-02: Quick-Build Funding Program

SR-03: Quick-Build Regional Toolkit

SR-07: Intersection Control Evaluation Policy

SR-08: Access Management / Traffic Impact Study Policy

SR-16: State DOT Design Relaxation

SR-17: Standard Details for Safety Countermeasures

SS-01: Dynamic Speed Display / Feedback Signs

SV-02: Vehicle Fleet Safety Training

SV-03: Update Vehicle Procurement Standards

Long-Term

PCC-02: Emergency Pull-Off Areas

PCC-03: Enhanced Wayfinding

SR-04: Safe Routes to School

SR-05: Sidewalk and Trail Inventory and Prioritization

SR-06: Sidewalk & Trail Removal Plan

SR-09: Complete Streets Policy

SR-10: Sidewalk Maintenance Policy

SR-18: Work Zone Training and Standardization

SS-04: Traffic Calming Policy

SS-05: Speed Management Plan

SAFETY METRICS

Infrastructure Targets (by 2040)*

Rural Shoulders

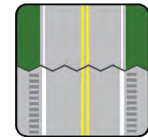

Install
4.5 miles

Curve Delineation



Modify
1 location

Traffic Calming

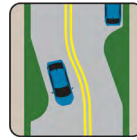

Install
8 locations

Active Mobility Facilities



Install
1.1 miles

*Targets set as of 2025.

Planning:

Completed or updated in the last 10 years

- Complete Streets Design Standards
- Traffic Calming Policy
- Traffic Impact Study Guidance
- Active Mobility Plan
- Safe Routes to School

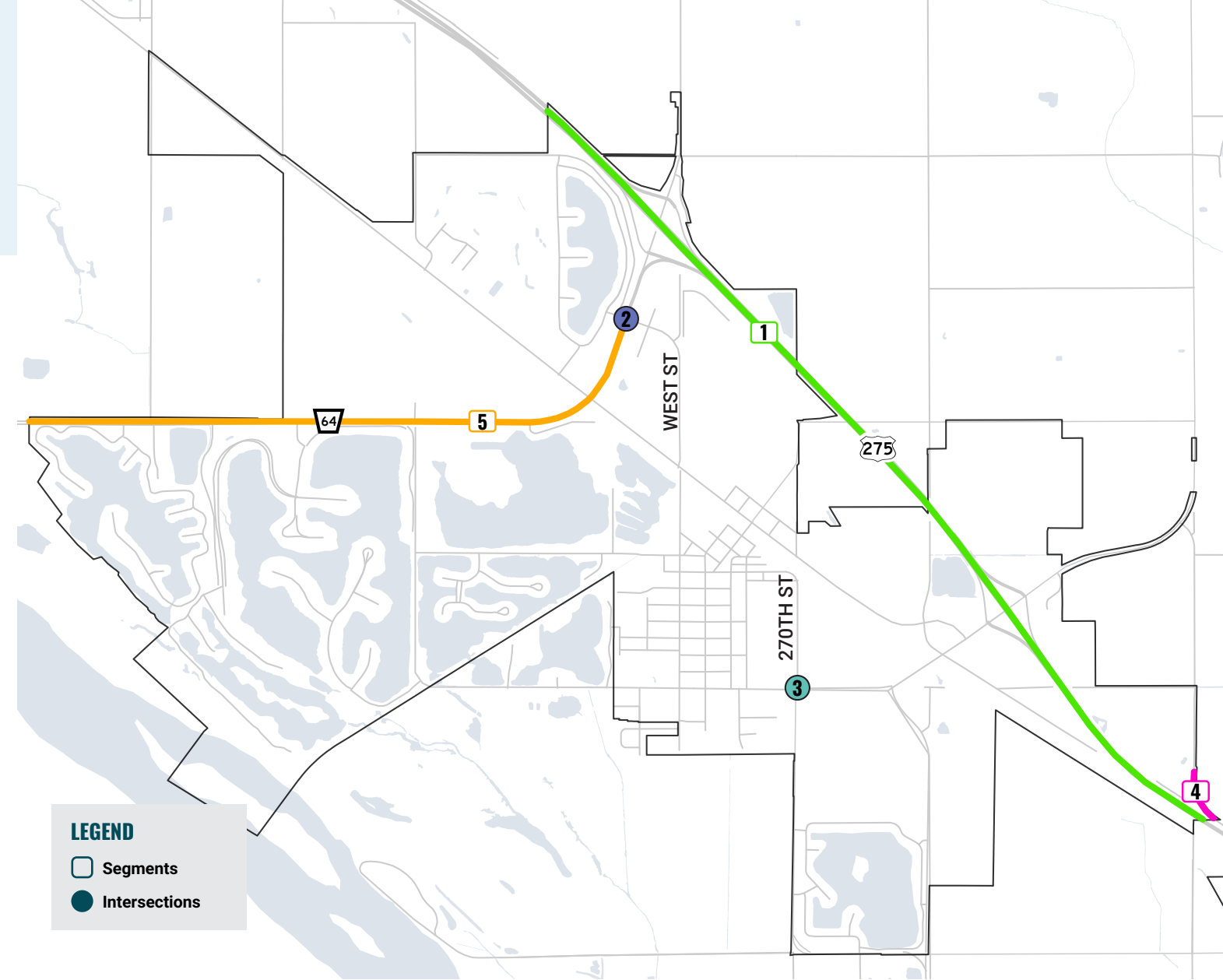

PRIORITY SAFETY PROJECTS

	Location	Countermeasure	Planning-level Cost	Potential Lives Saved (20 Yrs)	Potential Serious Injuries Avoided (20 Yrs)	Benefit-to-Cost Ratio (NDOT)	Benefit-to-Cost Ratio (USDOT)
1	US-275	Cable Median Barrier	\$3,470,000	1.5	6.1	9.0	6.1
2	West St & Ida St	Single-Lane Roundabout	\$2,250,000	-	2.7	1.7	1.4
3	Center St & E Meigs St	Single-Lane Roundabout	\$2,250,000	-	2.7	0.9	1.3
4	252nd St	Curve Delineation Modifications	\$80,000	-	1.1	4.1	3.6
5	Ida St	Lane Departure Mitigation	\$320,000	-	0.6	4.4	1.4

Cindy Grove
Mayor



Cameron Gales
City Administrator
Cgales@valleyne.org

MEMORANDUM

To: City Council

From: Cameron Gales City Administrator

Date: May 13, 2025

Subject: Human Resource (HR) Consultant Summary

Current State:

The City of Valley currently utilizes the City Administrator, City Attorney and City Clerk to manage HR functions. Legal expenses related to interpreting employment laws, resolving conflicts, ensuring confidentiality, and providing specialized expertise in recruitment and retention have become a costly burden for our city as employment laws frequently change and a specialized opinion is needed. Hiring a dedicated HR consultant would shift much of the work currently done by City or employment attorney's to a firm who specializes in these complex issues. Additionally, hiring an HR consultant who can address confidential concerns anonymously could significantly improve access to the necessary resources for employees within the organization.

Recommendation:

Based on the comparison, **Cardinal HR** appears to be the best firm for comprehensive HR services. They offer a wide range of services, have extensive experience, and are highly professional and responsive. Their flexible approach and ability to tailor solutions to specific needs make them a strong choice to enhance HR processes and drive growth.

Comparison:

Scope of Services:

- **Cardinal HR** offers a broad range of HR services including leadership, recruiting, performance management, and coaching.
- **CFO Systems** focuses on fractional, interim, and project-based leadership, with an emphasis on recruiting and staffing.
- **Zelle** specializes in employee relations, compliance, and HR support for public entities.

Client Focus:

- **Cardinal HR** serves a diverse range of clients across various industries.
- **CFO Systems** aims to provide leadership for organizational growth and performance.
- **Zelle** is tailored to public entities, particularly the City of Valley.

Expertise and Experience:

- **Cardinal HR** has extensive experience in strategic and operational HR roles, with a strong emphasis on professionalism and responsiveness.
- **CFO Systems** offers experienced leadership to achieve organizational goals.

- **Zelle** has a strong focus on compliance and employee relations within the public sector.

Cardinal HR

Overview:

- **Location:** Omaha, NE
- **Services:** Fractional HR leadership, project-based HR guidance, recruiting and hiring services, manager coaching and development.
- **Client Range:** 1 to 2,000+ employees across various industries.
- **Mission:** Deliver exceptional, flexible HR leadership to drive growth, enhance workplace culture, and navigate HR complexities.
- **Key Features:**
 - Continuous HR leadership and guidance.
 - Performance management and progressive discipline.
 - Recruiting assistance.
 - Extensive experience in strategic and operational HR roles.
 - Professionalism and responsiveness.
- **Rate:** \$125 per hour.

CFO Systems

Overview:

- **Location:** Omaha, Ne
- **Services:** Fractional, interim, project-based HR leadership, recruiting, staffing.
- **Client Range:** More than 1,000
- **Mission:** Provide experienced leadership to achieve organizational goals.
- **Key Features:**
 - Clear view of performance.
 - Drive growth.
 - Connect with the right person for key roles.
- **Focus:** Achieve more, worry less.
- **Rate:** A deposit in the amount of \$3,500.00 will begin the engagement.
 - \$145 / Hour for a Senior Accountant.
 - \$185 / Hour for Controller and Human Resources.

Zelle Human Resource Solutions

Overview:

- **Location:** Lincoln, NE
- **Services:** Personalized employee relations support, HR compliance, recruitment process management, policy creation, employee relations.
- **Client Range:** More than 1,000
- **Mission:** Support the City of Valley with HR complexities.
- **Key Features:**
 - Confidentiality practices.
 - Coaching managers for effective employee conversations.
 - Compliance with federal, state, and local laws.
 - Liaison between legal counsel and City of Valley.
 - Extensive involvement with public entities.
- **Rate:** \$3,000.00 per month.



FRACTIONAL
INTERIM
PROJECT
RECRUITING
STAFFING

Achieve More. Worry Less.

Partner with experienced leadership for your organization.

Something is missing in your organization. You need to get a clearer view of your performance, drive growth, or connect with the right person for a key role.

How will you find experienced leadership to reach your goals?



Fractional, Interim, Project and Recruiting leadership— we're here to help you grow.



Over 3,500 Years of Experience

Navigate your specific goals with lessons learned across numerous industries and organizations. Our Directors find unique solutions to fit your needs.



“Get It Done” with Trusted Leaders

Bypass hiring hurdles, connect quickly to top talent, and ensure you get it done right. Find qualified people who can start contributing effectively and efficiently.



Our Team, Your Success

Draw from the largest team of fractional leaders in the nation. You'll get the proper match of skills and personality that best fit your culture.



Stop Wearing Multiple Hats

No one can do it all. Lean on our experts for impactful results in accounting, finance, HR, operations, and more. Elevate your organization with stability, consistency, and opportunities to grow.

SERVICES

We help middle market and lower middle market organizations nationwide.

FRACTIONAL

Consistent and Cost-Effective

Optimize your operations with dedicated leadership, tailored to your unique needs, without the full-time expense.

INTERIM

Bridge the Gap with Precision

During transitions or sudden vacancies, our seasoned leaders maintain continuity, enhancing your team and organizational momentum.

PROJECT

Targeted Leadership for Specific Goals

When there's a distinct mission looming, our experts step up, drive results, and lead projects to reach the finish line.

RECRUITING

Leadership with Lasting Impact

Our in-depth vetting process identifies and delivers top-tier leaders, giving you confidence that your next hire is a cultural **AND** talent fit.

STAFFING

Placement for Immediate Needs

From short-term assignments to long-term roles, we arrange the right talent to fit seamlessly into your team, driving value from day one.

"CFO Systems has **exceeded my expectations**. They helped build the financial team I've always wanted to **support our growth strategy**. On top of that, they are great people and fun to work with."

DAVE ARNOLD, PRESIDENT

Royal Engineered Composites

WHY CFO SYSTEMS?



A Partner in Your Success

We aren't consultants. We roll up our sleeves and partner with our clients' teams to build necessary processes and practices.



The Nation's Largest Team of Fractional Leaders

We match organizations and talent by understanding your culture. You'll get impactful people who have the skills and personality to be the right fit.



We Succeed When Our Clients Outgrow Us

We help you identify and overcome your obstacles, then build a sustainable model for success.

Get stable, consistent leadership for your organization. **Imagine how you can grow with experienced partners beside you.**



FRACTIONAL
INTERIM
PROJECT
RECRUITING
STAFFING



City of Valley

Consulting Proposal

March 20,

2025

Presented by
Zelle Human Resource Solutions

Why Work with Us?

Zelle Human Resource Solutions provides comprehensive HR consulting services to leadership, managers, and employees. With this retained HR proposal, Zelle will establish specific goals at the beginning of our partnership and be onsite as needed to execute on those goals alongside your team. We integrate with your employees and strategically align with you to make HR an indispensable part of your business. Our recommended solutions are not an all-inclusive list, as every organization is different, and we take a customized approach to each.



1,000+

Current clients in all industries

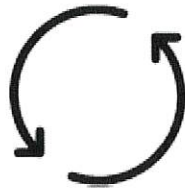

High client retention rates



10

Partnerships as the preferred HR Provider



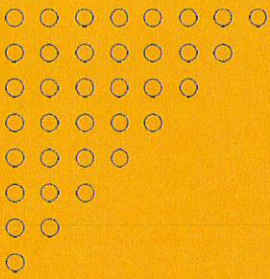

Who We Are + What We Do.

Zelle Human Resource Solutions is Nebraska's human resource leader - created to deliver outstanding service in the areas of human resources and recruiting. Today, Zelle serves more than 1,000+ clients and our motto has always remained the same: a Midwestern work ethic built on sound principles of commitment and loyalty. We lead with humility and deliver results that go beyond your expectations. No pre-made playbook here. Just simple, solid business practices.



Our Services Include:

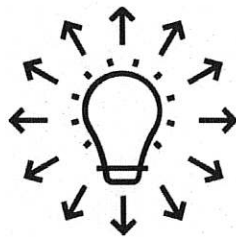

HR Consulting

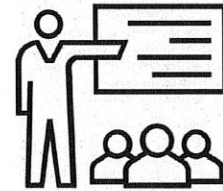

Employee + Leadership
Development

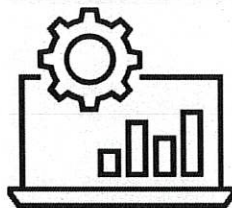

Talent Assessments

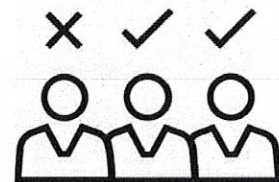

Direct Hire +
Recruitment Management

How We Do What We Do Best.

HR Compliance

As your HR partner, Zelle works to minimize risk and boost current HR processes and procedures to ensure compliance with all local, state, and federal laws. The compliance umbrella is multifaceted and may include record keeping and documentation with ADA, FMLA, Worker's Compensation, unemployment, leaves of absences, and terminations. Zelle may also evaluate benefits, job descriptions, employee handbook and supplemental policies, investigations, and onboarding. In addition, Zelle may assist with annual or dynamic HR-related compliance filings, as requested.

Customized Employee + Development

Zelle believes creating a strong employee, manager and leadership development philosophy is critical to the success of your organization's overall culture, retention, and employee engagement. In conjunction with your team, Zelle will establish goals for participants to achieve at the end of training sessions or program. Then, utilizing our library of custom courses, we will design content and deliverables to ensure the established goals are met.

Culture + Strategy

Culture enhances organizational performance when people understand it and know how to live it out. Zelle intentionally immerses our team members into your organization's culture to create a trusting, positive relationship your team. Zelle has numerous culturally driven solutions for organizations to gain a deeper understanding of their culture. Each of these solutions are entirely customizable and may include an anonymous culture assessment survey, 360 review, SWOT analysis, strategic planning session, organizational development, or succession planning.

More Solutions



How We Do What We Do Best.

Employee Relations

An organization's most important investment is in its people. However, numerous employee relation scenarios may involve time-sensitive action, compliance with record keeping, navigating labor laws, or lead to conflict resolution and mitigation. Zelle can manage all HR-related scenarios for ADA, FMLA, Worker's Compensation, terminations, unemployment, leaves of absences, performance conversations, and conflict resolution, as requested. Zelle supports ongoing employee relations by providing confidential, compliant assistance to leadership, managers, and employees.

Employee Benefits + Compensation

Your organization's benefits and compensation can set you apart from competitors, help retain your top talent, and be a persuasive recruiting tool. To ensure your organization's benefits and compensation are top notch, Zelle may analyze your current benefit offerings, compensation philosophy and plans. Zelle has wide-spread knowledge in numerous industries ranging from large organizations to non-profits to start-up businesses. Our partnerships and resources allow us to provide transparent guidance and advice. Zelle may suggest a 'request for proposal' process to ensure your organization's benefits are superior, a compensation analysis to provide insight into market comparatives, or support leadership with market trends and research that project valuable insights for future plans.

Recruitment Management

Finding top talent for your organization takes time, effort, and a keen eye. Zelle's Recruitment Management team will manage your organization's entire recruiting process. Zelle uses our own marketing team to help post open positions on effective job boards, social media platforms, and run marketing campaigns, as requested. Zelle will then source and screen qualified applicants and pass along candidates who meet the specified competencies, as well as adhere to your organization's mission and values. After internal review, Zelle will communicate and coordinate interviews and administer assessments, if requested. When a final candidate is selected, Zelle will work closely with the hiring managers and the candidate to finalize an offer and acceptance. Zelle may run background checks and schedule first day onboarding, as requested, to complete the hiring process.

Statement of Work

Zelle Human Resource Solutions has completed several HR projects and is heavily involved with our public entities. Here are a few ways we do this:

- Manage the recruitment process from posting open positions, phone screening, scheduling interviews with hiring managers, offering candidates the job, and initiating onboarding.
- Review current HR policies, procedures, and practices to ensure compliance with federal, state, and local laws. In addition, we ensure these exist to be used and followed versus utilizing a template that doesn't align with the City of Valley. These projects could include the employee handbook, job descriptions, pay practices, administration of FMLA, worker's compensation, and health and retirement benefits.
- Support city officials, department heads, and council members in employee relation matters. This could include conflict mitigation and resolution, documenting performance or behavioral concerns, and assisting employees who have HR-related questions.
- Recommend HR best practices and approaches that work well within the public sector to remain transparent with employees, competitive within your region, up to date with ever changing legislation, and ways to improve overall culture and engagement. This may be done through a compensation analysis, performance reviews, a culture survey, or career path creation.

Let's Get to Work, Together.

Meet the City of Valley HR Team!



Jamie Mohrman
City of Valley HR Lead



Brooke Minnick
City of Valley HR Specialist



Olivia Wells
City of Valley Recruiter

Total Investment.

Solution	Monthly Investment	Term
Retained HR Consulting	\$3,000	12-month agreement



WESTERN NEBRASKA OFFICE
COMING SOON!
OGALLALA, NEBRASKA 69153

ZELLE HEADQUARTERS
3606 SOUTH 48TH ST.
LINCOLN, NEBRASKA 68506

COLUMBUS OFFICE
1464 26TH AVE.
COLUMBUS, NEBRASKA 68601

OMAHA OFFICE
COMING SOON!
OMAHA, NEBRASKA

WWW.ZELLEHR.COM | 402.323.1664 | CONNECT@ZELLEHR.COM



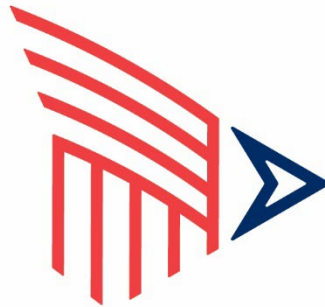

CARDINAL HR

Proposal of Services for the City of Valley

ABOUT CARDINAL HR

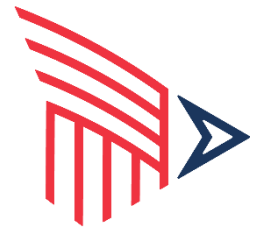

Cardinal HR is a fractional Human Resources (HR) company based in Omaha, NE. We provide HR leadership and support to clients throughout Nebraska and across the United States. Our clients range in size from 1 to 2,000+ employees and cover a variety of industries. Our mission is to deliver exceptional, flexible HR leadership that drives growth, enhances workplace culture, and enables organizations to navigate HR complexities with confidence.

We believe human resources leadership is fundamental to every business, but we know a full-time hire is not always necessary or affordable. We pride ourselves on delivering customized solutions that align with our clients' goals and scale with their growth. Our services include fractional HR leadership, project-based HR guidance and support, recruiting and hiring services, and one-on-one manager coaching and development.

WHAT OUR CLIENTS SAY

- Cardinal HR partnered with our management team to navigate organizational changes and provide coaching on employee performance issues. Kristan took time to understand our organizational culture and tailored her approach to meet our specific needs and help us improve our team dynamics.
- Partnering with Kristan has been one of the best investments I have made for my company, and I highly recommend Cardinal HR services.
- Kristan maintains the highest level of professionalism acting as the Human Resources Director for our Organization. She has demonstrated the ability to work seamlessly with us, such that our employees view her as part of our organization.
- Kristan was so professional and responsive. She made the hiring process easy and became a trusted team member. I hired a promising employee, in a position that had been empty for some time. I would also emphasize the professionalism and promptness of the service received at an incredibly cost-effective price.

PROJECT OVERVIEW

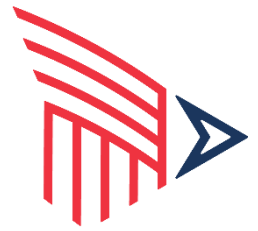

This proposal outlines the Human Resources (HR) leadership and support services needed as discussed with the City Administrator for the City of Valley. The goal of this engagement is to enhance and streamline HR processes through a flexible approach, adapting to the city's needs and minimizing overhead costs associated with a full-time HR staff member. As a trusted partner, Cardinal HR will work with the City Administrator and other city leaders to align HR processes with the city's business objectives and goals. Cardinal HR will provide professional human resources leadership and support at a bill rate of \$125 per hour.

1. General Human Resources Support

- Provide continuous HR leadership and guidance to address evolving questions and challenges
- Support leaders through employee investigations, including interviews and proper documentation; confirming the investigation is thorough, unbiased, and fair to all parties

2. Performance Management and Progressive Discipline

- Offer coaching and support to both employees and leaders to ensure alignment with goals and individual development
- Address performance issues promptly by guiding leaders through a step-by-step approach, from verbal warnings to written documentation and potential termination if necessary
- Ensure performance reviews are conducted on a consistent basis and employee performance is assessed in a structured, objective, and fair manner

3. Recruiting

- Assist with recruiting as needed, including job descriptions, resume reviews, applicant screening, and reference checks to evaluate candidate qualifications and experience

KRISTAN POAST, PHR, SHRM-CP

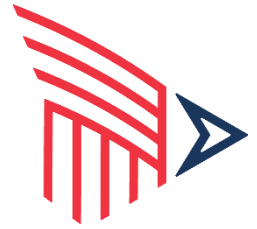

Kristan Poast is a dedicated human resources professional with extensive experience in both strategic and operational roles. Her passion lies in aligning human capital initiatives with business objectives to drive organizational success. Throughout her career, she has designed and implemented programs that attract and retain top talent while enhancing employee engagement across all levels of the organization.



Kristan prides herself on being a trusted partner to both leadership and employees, advocating for a balanced approach that considers the needs of the workforce and the business. Her commitment to people-centered solutions ensures that organizations can adapt, grow, and succeed in today's dynamic landscape.

Kristan has supported organizations in a variety of roles including fractional, interim and project-based HR leadership. Her recent client work has focused on manager and executive coaching, recruiting and onboarding, compensation analysis, policy creation, performance management and overall human resources strategy.

RESUME

- Cardinal HR, LLC – Founder & President
- CFO Systems LLC – Human Resources Director
- Accenture – Human Resources Partner (Contract)
- Advisor Group/Securities America, Inc. – Human Resources Partner, Corporate Recruiter
- Kiewit Corporation/Kiewit Building Group – Recruiting Manager, District Learning Manager, District Recruiting and Outreach Coordinator

Cindy Grove
Mayor



Cameron Gales
City Administrator
Cgales@valleyne.org

MEMORANDUM

To: Mayor & City Council

From: Cameron Gales City Administrator

Date: May 9, 2025

Subject: Core & Main Meter Reading Upgrade

Recommendation:

Requesting City Council approval to move forward with the utility upgrade to an Automated Meter Infrastructure with Antenna. All included cost for first year maintenance and customer service \$ 112,952.48

Current State:

In November 2024, People Service had a 77% success rate in reading correctly working meters. This process entails collecting signals as they drive every street throughout Valley. Manual meter reading is an old, outdated process that will not keep pace with Valley's growth. Abnormal changes in usage go unnoticed until the meters are read at the end of the month, which could potentially be 30 days later.

Positive improvements are underway to address the accuracy and transparency of the utility billing system. We look to address 30-day delays in usage updates and target manual meter reading accuracy. Since hiring Kindra, the Utility Clerk, we have seen improvements; however, not all methods used are long-term solutions to keep up with growth.

The first step in this process involves updating our current system to an Automated Metering Infrastructure System / Antenna. The antenna will be installed on the water tower to import real-time water consumption data. Core & Main conducted a propagation study estimating the number of endpoint connections (meters) a single antenna could support. The study found that one antenna would provide significant coverage for Valley, with the capacity to serve up to 25,000 additional residents before an additional antenna would be required.

Benefits of the Upgrade:

- Consistent coverage for the current 1,590 meters

- Utilization of broadband signaling to communicate with meters continuously.
- Dashboard capability to empower citizens in monitoring and controlling usage.
 - Leaving town, you will be in control by having your system decrease down to a trickle until you return.
- Real-time water usage monitoring.
 - Citizens have questions about water usage; the utility clerk can provide real time usage.
- Ability to adjust water flow during unexpected move-outs or shutoffs.
 - In Valley we also have properties that take advantage of having one water line feeding into two properties/meters. In these situations, if one home fails to pay their bill, we don't have any means to reduce or disconnect services from the property that's behind.



Bid Proposal for Valley, NE AMI Upgrade

CITY OF VALLEY

Job Location: Valley, NE
Bid Date: 08/19/2024 05:00 pm
Core & Main Bid #: 3705980

Core & Main
 10707 S 149th St
 Omaha, NE 68138
Phone: 4028966173
Fax: 4028966379

Seq#	Qty	Description	Units	Price	Ext Price
20		AMI HARDWARE			
40	1	M400B2 BASE STATION W/SPM-900	EA	37,746.98	37,746.98
60	1	L&S INSTALL OF ANTENNA	EA	25,193.75	25,193.75
				SUBTOTAL	62,940.73
80		RNI & SA SOFTWARE			
100	1	SENSUS SAAS RNI - SETUP FEE	EA	8,755.00	8,755.00
110	1	SENSUS ANALYTICS - SETUP FEE	EA	4,125.00	4,125.00
120	1	TRAINING - SENSUS AMI FLEXNET CORE EDUCATION - REMOTE	EA	3,000.00	3,000.00
130	1	SENSUS ANALYTICS - STANDARD INTEGRATIONS	EA	8,593.75	8,593.75
150		1ST YEAR ANNUAL SOFTWARE FEES			
160		3% INCREASE ANNUALLY			
170	1	SENSUS SAAS RNI - ANNUAL FEE	EA	10,270.00	10,270.00
180	1	SENSUS ANALYTICS - WATER - ANNUAL FEE	EA	10,270.00	10,270.00
				SUBTOTAL	45,013.75
190		PROJECT MANAGEMENT			
210	1	C&M PROJECT MANAGEMENT FEE	EA	5,000.00	5,000.00
				SUBTOTAL	5,000.00
230		ALLY WATER METER			
240	0	ALLY WATER METER WITH SHUT OFF BALL VALVE	EA	565.60	0.00
				Sub Total	112,954.48
				Tax	0.00
				Total	112,954.48

UNLESS OTHERWISE SPECIFIED HEREIN, PRICES QUOTED ARE VALID IF ACCEPTED BY CUSTOMER AND PRODUCTS ARE RELEASED BY CUSTOMER FOR MANUFACTURE WITHIN THIRTY (30) CALENDAR DAYS FROM THE DATE OF THIS QUOTATION. CORE & MAIN LP RESERVES THE RIGHT TO INCREASE PRICES TO ADDRESS FACTORS, INCLUDING BUT NOT LIMITED TO, GOVERNMENT REGULATIONS, TARIFFS, TRANSPORTATION, FUEL AND RAW MATERIAL COSTS. DELIVERY WILL COMMENCE BASED UPON MANUFACTURER LEAD TIMES. ANY MATERIAL DELIVERIES DELAYED BEYOND MANUFACTURER LEAD TIMES MAY BE SUBJECT TO PRICE INCREASES AND/OR APPLICABLE STORAGE FEES. THIS BID PROPOSAL IS CONTINGENT UPON BUYER'S ACCEPTANCE OF SELLER'S TERMS AND CONDITIONS OF SALE, AS MODIFIED FROM TIME TO TIME, WHICH CAN BE FOUND AT: <https://coreandmain.com/terms-of-sale/>

THIS BID MAY INCLUDE GLOBALLY SOURCED (IMPORTED) MATERIALS THAT ARE SUBJECT TO CHANGING TARIFFS. PRICES ARE SUBJECT TO CHANGE DUE TO POTENTIAL ADDITIONAL TARIFFS IMPOSED BY THE U.S. GOVERNMENT. IF IMPOSED, PRICES WILL INCREASE BY THE SAME PERCENTAGE AND WILL BE EFFECTIVE ON THE DATE THAT THE NEW TARIFFS ARE IMPLEMENTED. THESE ITEMS SHOULD BE PURCHASED WITH HASTE TO AVOID ANY ADDITIONAL RISING TARIFF COSTS.



ally® Smart Water Meter

Electromagnetic Flow Measurement with Remote Management Valve

The Sensus ally® water meter features an integrated 3-state valve, temperature and pressure sensors and alarms. ally has no moving parts and is based on our innovative electromagnetic flow measurement technology.

Industry Leading Performance

The patented measurement technology of the ally meter provides continuous and enhanced accuracy ranges at both low and high flows and perpetual accuracy over the life of the product. Accuracy is not effected by various flow conditions, disturbances, or particulates in the water system. The ally meter has a 15-year life cycle, along with a 15-year accuracy warranty.

FEATURES

- 5/8", 5/8" x 3/4", 3/4", and 1" sizes available in potable and reclaim versions
- Starts registering flow as low as 0.03 gpm (0.007 m³/hr)
- Can be installed horizontally, vertically or diagonally
- Compatible with current Sensus AMI systems

BENEFITS

- Control three states of water flow remotely (on, off, reduced)
- Detect leaks to save money and conserve water
- Monitor pressure conditions and temperature conditions
- Smart alarms including empty pipe, high flow, reverse flow, low and high pressure and temperature, customer leak and tamper

Construction

The ally is an integrated unit that incorporates an electronic register, 3-state valve, temperature sensor, pressure sensor, and a measuring device encased in an external housing. The measuring device is comprised of a composite alloy flowtube with externally-threaded spud ends.

Electronic Register

The high resolution 9-digit electronic register was designed to eliminate dirt and moisture contamination in pit settings. The tempered glass register cover displays readings with the AMI digits highlighted. Direction of flow, rate of flow and units of measure are also easily readable on the register display. The ally register features programmable AMI resolution and unit of measure, and integral customer data logging of up to 120 days. The display includes battery life, empty pipe, forward/reverse flow, flow rate, leak and tamper, valve, pressure, and temperature indicators. Additionally, the register displays temperature and pressure values, valve state, and active and recent alarms.

Shut-Off Valve

The shut-off valve has 3 states—open, closed, and reduced flow. Reduced flow mode allows 1-2 GPM on average for life sustaining applications (based on 65 psig). The stainless steel ball valve is self cleaning and remains functional due to automatic seat exercising. The ally meter also contains a proprietary actuator to operate the valve.

Tamperproof

The integrated construction of the ally meter prevents removal of the register to obtain free water. The magnetic tamper and low field alarms will both indicate any attempt to tamper with the magnetic field of the ally meter. The meter communication alarm indicates a possible cut cable.

ally® Smart Water Meter

Electromagnetic Flow Measurement with 3-State Valve

Smart Alarms

ally meters have many configurable smart alarms designed to protect your utility's investment, enhance customer service, and monitor/optimize distribution systems. These alarms include:

- Empty Pipe
Detects the absence of water in the flow tube and sends an alert. Allows you to identify main breaks downstream and water shortages for quicker resolution to ensure water availability. This alarm can also indicate the water meter has been removed from service, or notify you of potential tamper.
- Tampering
Detect magnetic interference to reduce apparent water losses and protect against unauthorized activities.
- Customer Leak
Detect continual consumption of water over a period of time to indicate downstream leaks. This protects your utility, infrastructure and customers through alarm notifications that can reduce water loss and leak adjustment costs.
- Low Battery
Replace your meters before they stop recording consumption through alerts indicating battery capacity to the meter or valve is running low.
- Reverse Flow
Keep untreated water from re-entering your distribution system and deter tampering attempts through an alarm triggered when reverse flow is detected at the meter.
- High Flow
Detect broken pipes and reduce property damage through an alert triggered by the detection of excessive flow rates.
- Pressure
Get alerted when water pressure exceeds or falls below the pressure threshold to prevent potential disruptions of service.
- Temperature
Get alerted when water temperature exceeds or falls below the temperature threshold so you can take action to better protect your meter and water network assets.

SPECIFICATIONS

Service	Measurement of potable and reclaim water. 0-100% humidity. Fully submersible. IP68+ rated.			
Temperature Ranges	Water operating: Ambient air operating: Storage air:	33 °F (0.55 °C) to 80 °F (26.7 °C) -22 °F (-30 °C) to 140 °F (60 °C) -30 °F (-34.4 °C) to 158 °F (70 °C)		
Starting flow	5/8" (DN 15 mm) size: 0.03 gpm (0.007 m ³ /h)	5/8" x 3/4" (DN 15x20 mm) size: 0.03 gpm (0.007 m ³ /h)	3/4" (DN 20 mm) size: 0.03 gpm (0.007 m ³ /h)	1" (DN 25 mm) size: 0.11 gpm (0.025 m ³ /h)
Low flow range (±3%)	5/8" (DN 15 mm) size: >0.10 gpm (0.025 m ³ /hr) to <0.18 gpm (0.041 m ³ /hr)	5/8" x 3/4" (DN 15x20 mm) size: >0.10 gpm (0.025 m ³ /hr) to <0.18 gpm (0.041 m ³ /hr)	3/4" (DN 20 mm) size: >0.10 gpm (0.025 m ³ /hr) to <0.18 gpm (0.041 m ³ /hr)	1" (DN 25 mm) size: >0.3 gpm (0.068 m ³ /h) to <0.4 gpm (0.09 m ³ /h)
Normal operating flow range (±1.5%)	5/8" (DN 15 mm) size: 0.18 to 25 gpm (0.04 to 5.7 m ³ /hr)	5/8" x 3/4" (DN 15x20 mm) size: 0.18 to 35 gpm (0.04 to 8.0 m ³ /hr)	3/4" (DN 20 mm) size: 0.18 to 35 gpm (0.04 to 8.0 m ³ /hr)	1" (DN 25 mm) size: 0.4 to 55 gpm (0.09 to 12.5 m ³ /hr)
Sensor Accuracy	Pressure Sensor: ± 1.25% full scale for water temp 35-100 °F (0-200psi) Temperature Sensor: ± 2.00% full scale for water temp 35-100 °F (0-200psi)			
Maximum operating pressure	200 psi (13.8 bar)			
Measurement technology	Solid state electromagnetic flow			
Register	Hermetically sealed, 9-digit programmable electronic register			
Capacity	10,000,000 gallons, 1,000,000 cubic feet or 100,000 m ³ capacity.			
Register Resolution	.01 gallons/imperial gallons, .001 cubic foot, or .0001 m ³			
Conformance to Standards	Meets the requirements of NSF 61, Annex G and NSF 372. Exceeds the most current revision of AWWA Standard C-715.			
Materials	External housing - Thermal plastic Flowtube - Polyphenylene sulfide polymer		Electrode - Silver/silver chloride Register cover - Tempered glass	

ally® Smart Water Meter

Electromagnetic Flow Measurement with 3-State Valve

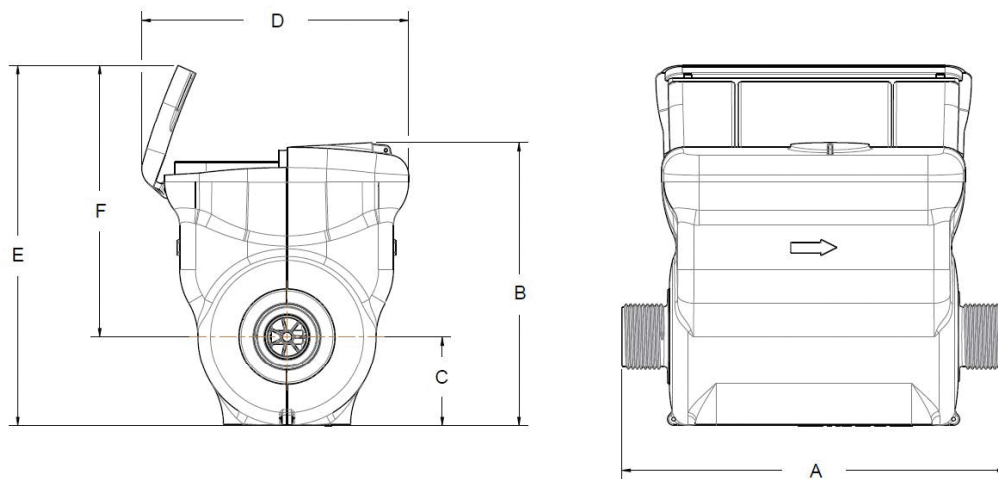

DIMENSIONS AND NET WEIGHTS

Size	A	B	C	D	E	F	Spud Ends	NPSM Thread Size	Width	Net Weight
5/8" (DN 15 mm)	7-1/2" (190 mm)	5-1/2" (140 mm)	1-3/4" (44 mm)	5-1/2" (140 mm)	7" (178 mm)	5-1/4" (133 mm)	5/8" (15 mm)	3/4" (20 mm)	4-3/4" (121 mm)	3.3 lb. (1.5 kg)
5/8" x 3/4" (DN 15 mm x 20 mm)	7-1/2" (190 mm)	5-1/2" (140 mm)	1-3/4" (44 mm)	5-1/2" (140 mm)	7" (178 mm)	5-1/4" (133 mm)	3/4" (20 mm)	1" (25 mm)	4-3/4" (121 mm)	3.3 lb. (1.5 kg)
3/4" Short (DN 20 mm)	7-1/2" (190 mm)	5-1/2" (140 mm)	1-3/4" (44 mm)	5-1/2" (140 mm)	7" (178 mm)	5-1/4" (133 mm)	3/4" (20 mm)	1" (25 mm)	4-3/4" (121 mm)	3.3 lb. (1.5 kg)
3/4" (DN 20 mm)	9" (229 mm)	5-1/2" (140 mm)	1-3/4" (44 mm)	5-1/2" (140 mm)	7" (178 mm)	5-1/4" (133 mm)	3/4" (20 mm)	1" (25 mm)	4-3/4" (121 mm)	3.4 lb. (1.54 kg)
1" (DN 25 mm)	10-3/4" (273 mm)	5-1/2" (140 mm)	1-3/4" (44 mm)	5-1/2" (140 mm)	7" (178 mm)	5-1/4" (133 mm)	1" (25 mm)	1-1/4" (32 mm)	4-3/4" (121 mm)	3.8 lb. (1.72 kg)

ally® Smart Water Meter

Electromagnetic Flow Measurement with 3-State Valve

Head Loss Curves

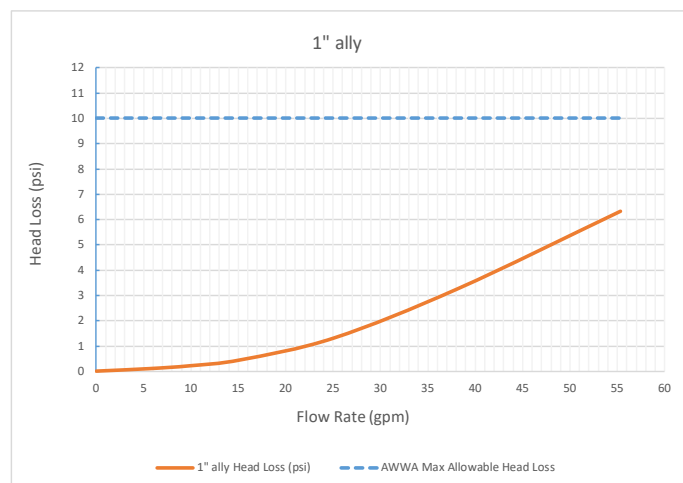
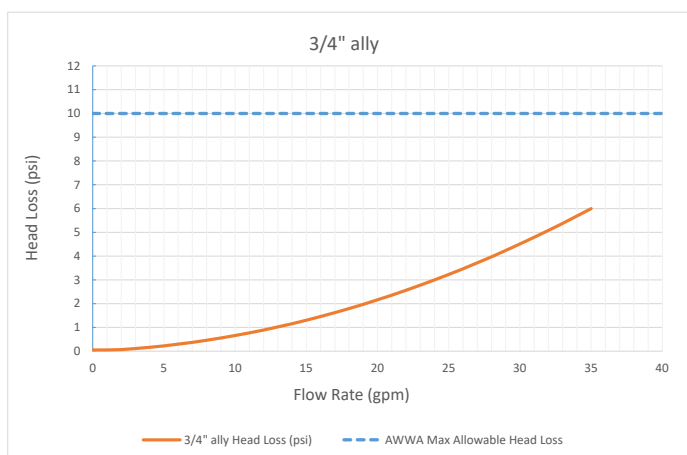
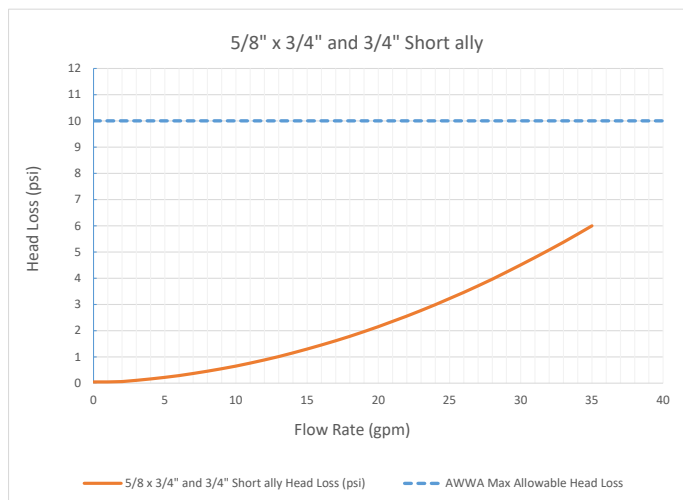
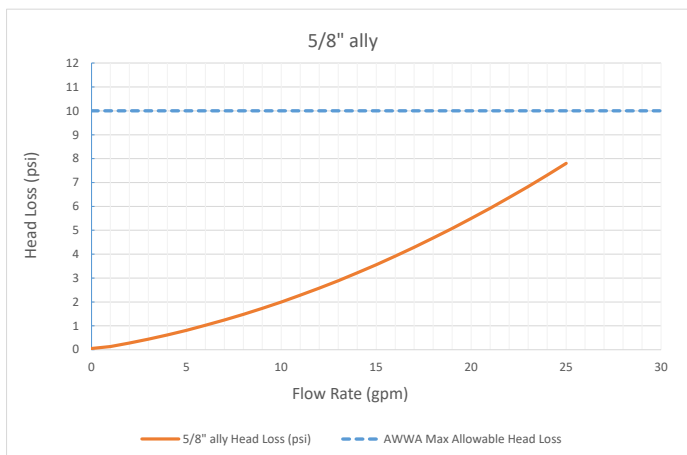

ORDINANCE NO. 836

AN ORDINANCE TO AMEND EXISTING SECTIONS OF THE CITY OF VALLEY ZONING REGULATIONS RELATING TO SHOUSES, ALSO KNOWN AS BARNDOMINIUMS; PROVIDING FOR AN EFFECTIVE DATE OF THIS ORDINANCE, PROVIDING FOR A SEVERABILITY CLAUSE; AND PROVIDING FOR THE REPEAL OF ALL ORDINANCES IN CONFLICT HEREWITH.

BE IT ORDAINED BY THE MAYOR AND CITY COUNCIL OF THE CITY OF VALLEY, DOUGLAS COUNTY, NEBRASKA, AS FOLLOWS:

Section 1. Section 2.03 (Definitions) of the City of Valley Zoning Regulations shall be amended so that the definition of a **DWELLING UNIT, SPECIAL TYPES**, shall read as follows:

DWELLING UNIT, SPECIAL TYPES shall mean any dwelling type consisting of single-family detached; single-family attached, multi-family, mobile home that is not meet the typical construction style of traditional stick framed structures.

1. **Cargo Container Dwelling:** a dwelling unit constructed of one or more new or used cargo containers used for multi-modal shipping and meeting the definition of dwelling unit above.
2. **Grain Bin Dwelling Unit:** A dwelling unit constructed of one or more grain bins, new or used meeting the definition of Dwelling Unit above.
3. **Quonset home:** A home constructed beneath and in a structure referred to as a Quonset.
4. **Shouse:** A structure that combines a dwelling space with a shop or garage and is primarily used as a dwelling. Shouses are often made of steel or wood, and can be built in a variety of sizes and designs. A dwelling where the garage square footage exceeds the dwelling square footage. Also known as a Barndominium. See 9.22.06.
5. **Tiny House:** A structure containing living spaces including sleeping and kitchen areas which measure 500 square feet or less in area. Tiny houses can be either portable, on wheels similar to a recreational vehicle, or on a permanent foundation.
6. **Tree House:** A dwelling unit where the primary structure of the unit is based on one or more tree clusters.

Section 2. That existing Section 9.22.06 of the City of Valley Zoning Regulations is hereby repealed.

Section 3. That a new Section 9.22.06 of the City of Valley Zoning Regulations shall be inserted and shall read as follows:

9.22.06 Shouses

Any residential structure meeting the definition of a Shouse shall meet the following criteria:

1. Shouses shall be structurally anchored to a permanent continuous foundation and said foundation shall meet local, state, and/or federal building codes;
2. Once a Shouse has been established, the overall structure, including the shop area, will no longer be considered an agricultural structure/building;
3. Shouses homes shall have at least one habitable room with not less than 120 sf of gross floor area;
4. Other habitable rooms shall have not less than 70 sf of floor area, except for kitchens;
5. Habitable rooms shall not less than seven feet in any horizontal dimension;
6. Ceiling height effect on room area:
 - A. Portions of a sloped ceiling measuring less than five feet or a furred ceiling measuring less than seven feet from the finished floor;
 - B. The finished ceiling shall not be considered as contributing to the minimum required habitable area for the room;
7. Ceiling heights shall be a minimum of seven feet in habitable spaces, hallways, bathrooms, and toilet rooms;
8. Every dwelling shall have toilet facilities-water closet, lavatory, and a bathtub or shower;
9. Shouses shall have a kitchen area and sink;
10. The unit shall provide heating and cooling systems as required by local, state and/or federal codes;
11. All electrical shall be in compliance with all local, state and/or federal electrical codes;
12. The unit shall meet all egress requirements found in local, state, and/or federal codes;
13. Any and all extensions off the Shouse shall be structurally designed regarding all attachments and cantilevers;
14. All modifications needed to convert the machine shed into a dwelling unit shall be required to have all modifications designed and engineered by a licensed architect and/or engineering;
15. All items requiring the structure to be structurally designed/modified shall be sealed by a structural engineer;
16. All structures shall meet the maximum coverage on a lot like any ordinary single-family dwelling.
17. When building a shouse in an area zoned residential, all building materials shall be consistent with residential construction materials.
18. No garage side walls shall exceed 16 feet in height.
19. The garage space square footage shall be limited to one and one-half times the dwelling space square footage, provided, however, that the garage space square footage for a shouse in an area zoned Transitional

Agriculture (TA) shall be limited to five times the dwelling space square footage. Any use other than a garage shall require a commercial permit.

20. A minimum of one-hour firewall shall be constructed between any dwelling spaces abutting garage space.

Section 4. That a portion of the existing Section 5.06 (Land Use Categories/Matrix) of the City of Valley Zoning Regulations relating to Shouses is hereby repealed.

Section 5. That a new portion of Section 5.06 (Land Use Categories/Matrix) relating to Shouses is hereby added to the City of Valley Zoning Regulations as shown on Exhibit "A" attached hereto and incorporated herein by this reference.

Section 6. This Ordinance shall take effect and be in force after its passage and approval, as provided by law.

Section 7. If any section, clause, provision or part or portion of any section, clause or provision of this ordinance or the application thereof to any person or circumstance is held unconstitutional, such invalidity or unconstitutionality shall not affect the validity or application of any other section, clause, provision or part or portion of this ordinance.

Section 8. All ordinances, sections, or parts thereof in conflict herewith are hereby repealed.

PASSED AND APPROVED THIS 13th DAY OF MAY, 2025.

CITY OF VALLEY, DOUGLAS COUNTY, NEBRASKA

Cindy Grove, Mayor

ATTEST:

Christie Donnermeyer, City Clerk

**City of Valley
Valley, Nebraska**

Basic Financial Statements

September 30, 2024

DRAFT

**City of Valley, Nebraska
Table of Contents**

Independent Auditor's Report	1
Basic Financial Statements	
Government-wide Financial Statements	
Statement of Net Position	6
Statement of Activities	7
Governmental Funds Financial Statements	
Balance Sheet - Governmental Funds	8
Statement of Revenues, Expenditures and Changes in Fund Balances - Governmental Funds	9
Proprietary Funds Financial Statements	
Statement of Net Position - Proprietary Funds	10
Statement of Revenues, Expenses and Changes in Net Position - Proprietary Funds	11
Statement of Cash Flows - Proprietary Funds	12
Notes to Basic Financial Statements	13
Supplementary Information	
Schedule of Revenues, Expenditures and Changes in Fund Balance - Budget and Actual - Governmental Funds (Excluding Debt Service Fund)	28
Schedule of Revenues, Expenditures and Changes in Fund Balance - Budget and Actual - Debt Service Fund	29
Schedule of Revenues, Expenditures and Changes in Fund Balance - Budget and Actual - Proprietary Funds	30
Notes to Budgetary Comparison Schedule	31
Schedule of Expenditures of Federal Awards	32
Notes to Schedule of Expenditures of Federal Awards	33
Report on Internal Control over Financial Reporting and on Compliance and Other Matters Based on an Audit of Financial Statements Performed in Accordance with <i>Government Auditing Standards</i>	34
Report on Compliance for each Major Federal Program and on Internal Control Over Compliance in Accordance with the Uniform Guidance	36
Schedule of Findings and Questioned Costs	39
Schedule of Prior Audit Findings	41

INDEPENDENT AUDITORS' REPORT

To the Honorable Mayor and Members of the City Council
City of Valley, Nebraska

Report on the Audit of the Financial Statements

Opinions

We have audited the financial statements of the governmental activities, the business-type activities and each major fund of the City of Valley, Nebraska (the City) as of and for the year ended September 30, 2024, and the related notes to the financial statements, which collectively comprise the City's basic financial statements as listed in the table of contents.

In our opinion, the accompanying financial statements present fairly, in all material respects, the respective financial position of the governmental activities, the business-type activities and each major fund of the City, as of September 30, 2024, and the respective changes in financial position and, where applicable, cash flows thereof for the year then ended in accordance with accounting principles generally accepted in the United States of America.

Basis for Opinions

We conducted our audit in accordance with auditing standards generally accepted in the United States of America (GAAS) and the standards applicable to financial audits contained in *Government Auditing Standards*, issued by the Comptroller General of the United States. Our responsibilities under those standards are further described in the Auditor's Responsibilities for the Audit of the Financial Statements section of our report. We are required to be independent of the City and to meet our other ethical responsibilities, in accordance with the relevant ethical requirements relating to our audit. We believe that the audit evidence we have obtained is sufficient and appropriate to provide a basis for our audit opinions.

Emphasis of Matter

As discussed in Note 12 to the financial statements, the 2023 financial statements have been restated due to the City moving to a basis of accounting in accordance with accounting principles generally accepted in the United States of America. Our opinion is not modified with respect to this matter.

INDEPENDENT AUDITORS' REPORT (Continued)

Responsibilities of Management for the Financial Statements

The City's management is responsible for the preparation and fair presentation of the financial statements in accordance with accounting principles generally accepted in the United States of America, and for the design, implementation, and maintenance of internal control relevant to the preparation and fair presentation of financial statements that are free from material misstatement, whether due to fraud or error.

In preparing the financial statements, management is required to evaluate whether there are conditions or events, considered in the aggregate, that raise substantial doubt about the City's ability to continue as a going concern for twelve months beyond the financial statement date, including any currently known information that may raise substantial doubt shortly thereafter.

Auditor's Responsibilities for the Audit of the Financial Statements

Our objectives are to obtain reasonable assurance about whether the financial statements as a whole are free from material misstatement, whether due to fraud or error, and to issue an auditor's report that includes our opinions. Reasonable assurance is a high level of assurance but is not absolute assurance and therefore is not a guarantee that an audit conducted in accordance with GAAS and *Government Auditing Standards* will always detect a material misstatement when it exists. The risk of not detecting a material misstatement resulting from fraud is higher than for one resulting from error, as fraud may involve collusion, forgery, intentional omissions, misrepresentations, or the override of internal control. Misstatements are considered material if there is a substantial likelihood that, individually or in the aggregate, they would influence the judgment made by a reasonable user based on the financial statements

In performing an audit in accordance with GAAS and *Government Auditing Standards*, we:

- Exercise professional judgment and maintain professional skepticism throughout the audit.
- Identify and assess the risks of material misstatement of the financial statements, whether due to fraud or error, and design and perform audit procedures responsive to those risks. Such procedures include examining, on a test basis, evidence regarding the amounts and disclosures in the financial statements.
- Obtain an understanding of internal control relevant to the audit in order to design audit procedures that are appropriate in the circumstances, but not for the purpose of expressing an opinion on the effectiveness of the City's internal control. Accordingly, no such opinion is expressed.
- Evaluate the appropriateness of accounting policies used and the reasonableness of significant accounting estimates made by management, as well as evaluate the overall presentation of the financial statements.
- Conclude whether, in our judgment, there are conditions or events, considered in the aggregate, that raise substantial doubt about the City's ability to continue as a going concern for a reasonable period of time.

We are required to communicate with those charged with governance regarding, among other matters, the planned scope and timing of the audit, significant audit findings, and certain internal control-related matters that we identified during the audit.

INDEPENDENT AUDITORS' REPORT (Continued)

Required Supplementary Information

Management has omitted the management's discussion and analysis that accounting principles generally accepted in the United States of America require to be presented to supplement the financial statements. Such missing information, although not a part of the financial statements, is required by the Governmental Accounting Standards Board who considers it to be an essential part of financial reporting for placing the financial statements in an appropriate operational, economic, or historical context. Our opinions on the financial statements are not affected by this missing information.

Accounting principles generally accepted in the United States of America require that the budgetary comparison information on pages 29–31 and be presented to supplement the financial statements. Such information is the responsibility of management and, although not a part of the financial statements, is required by the Governmental Accounting Standards Board who considers it to be an essential part of financial reporting for placing the financial statements in an appropriate operational, economic, or historical context. We have applied certain limited procedures to the required supplementary information in accordance with auditing standards generally accepted in the United States of America, which consisted of inquiries of management about the methods of preparing the information and comparing the information for consistency with management's responses to our inquiries, the basic financial statements, and other knowledge we obtained during our audit of the basic financial statements. We do not express an opinion or provide any assurance on the information because the limited procedures do not provide us with sufficient evidence to express an opinion or provide any assurance.

Supplementary Information

Our audit was conducted for the purpose of forming opinions on the financial statements that collectively comprise the City's basic financial statements. The combining schedule of receipts, disbursements and changes in fund balance and schedule of expenditures of federal awards, as required by *Title 2 U.S. Code of Federal Regulations Part 200, Uniform Administrative Requirements, Cost Principles, and Audit Requirements for Federal Awards*, are presented for purposes of additional analysis and are not a required part of the basic financial statements. Such information is the responsibility of management and was derived from and relates directly to the underlying accounting and other records used to prepare the basic financial statements. The information has been subjected to the auditing procedures applied in the audit of the basic financial statements and certain additional procedures, including comparing and reconciling such information directly to the underlying accounting and other records used to prepare the basic financial statements or to the basic financial statements themselves, and other additional procedures in accordance with auditing standards generally accepted in the United States of America. In our opinion, the supplementary information described in the second sentence of this paragraph and the schedule of expenditures of federal awards are fairly stated, in all material respects, in relation to the basic financial statements as a whole.

INDEPENDENT AUDITORS' REPORT (Continued)

Other Reporting Required by *Government Auditing Standards*

In accordance with *Government Auditing Standards*, we have also issued our report dated May 15, 2025 on our consideration of the City's internal control over financial reporting and on our tests of its compliance with certain provisions of laws, regulations, contracts, and grant agreements and other matters. The purpose of that report is solely to describe the scope of our testing of internal control over financial reporting and compliance and the results of that testing, and not to provide an opinion on the effectiveness of internal control over financial reporting or on compliance. That report is an integral part of an audit performed in accordance with *Government Auditing Standards* in considering the City's internal control over financial reporting and compliance.

BLAND + ASSOCIATES, P.C.

Omaha, Nebraska
May 15, 2025

DRAFT

DRAFT

BASIC FINANCIAL STATEMENTS

City of Valley, Nebraska
Statement of Net Position
September 30, 2024

	Governmental Activities	Business-type Activities	Total
Assets			
Cash and cash equivalents	\$ 6,747,099	\$ 5,491,484	\$ 12,238,583
Cash with County Treasurer	137,342	-	137,342
Taxes receivable	437,484	-	437,484
Grants receivable	-	504,754	504,754
Accounts receivable	-	26,989	26,989
Lease receivable	-	1,340,574	1,340,574
Interest receivable	-	4,234	4,234
Internal balances	60,319	(60,319)	-
Capital assets			
Land	300,000	4,000	304,000
Construction in process	-	699,179	699,179
Buildings	753,504	941,040	1,694,544
Improvement/infrastructure	2,640,856	21,060,429	23,701,285
Equipment and furniture	1,483,011	408,821	1,891,832
Accumulated depreciation	(1,455,993)	(9,514,033)	(10,970,026)
Total assets	<u>11,103,622</u>	<u>20,907,152</u>	<u>32,010,774</u>
Liabilities			
Accounts payable	216,005	26,636	242,641
Accrued liabilities	89,589	35,787	125,376
Customer deposits	-	63,474	63,474
Current portion of long-term liabilities	308,603	665,226	973,829
Long-term liabilities	2,945,788	6,650,794	9,596,582
Total liabilities	<u>3,559,985</u>	<u>7,441,917</u>	<u>11,001,902</u>
Deferred Inflows of Resources			
Lease receivable	-	1,257,464	1,257,464
Net Position			
Net investment in capital assets	466,987	6,283,416	6,750,403
Restricted for			
Debt service	548,255	-	548,255
Community betterment	337,960	-	337,960
Community development	5,652,252	-	5,652,252
Unrestricted	538,183	5,924,355	6,462,538
Total net position	<u>\$ 7,543,637</u>	<u>\$ 12,207,771</u>	<u>\$ 19,751,408</u>

City of Valley, Nebraska
Statement of Activities
Year Ended September 30, 2024

Functions/Programs	Expenses	Program Revenues			Net Revenues (Expenses) and Changes in Net Assets		
		Charges for services	Operating Grants and Contributions	Capital Grants and Contributions	Governmental Activities	Business-type Activities	Net Total
Primary government							
Governmental activities							
General services	\$ 1,232,565	\$ 81,590	\$ 26,003	\$ -	\$ (1,124,972)	\$ -	\$ (1,124,972)
Public safety	860,551	336	-	-	(860,215)	-	(860,215)
Public works	1,331,634	2,926	74,279	-	(1,254,429)	-	(1,254,429)
Keno	14,865	-	-	-	(14,865)	-	(14,865)
Culture and recreation	239,523	3,451	-	-	(236,072)	-	(236,072)
Tax increment financing	4,353,191	-	-	-	(4,353,191)	-	(4,353,191)
Unallocated depreciation	337,799	-	-	-	(337,799)	-	(337,799)
Interest and fees	53,924	-	-	-	(53,924)	-	(53,924)
Total governmental activities	<u>8,424,052</u>	<u>88,303</u>	<u>100,282</u>	<u>-</u>	<u>(8,235,468)</u>	<u>-</u>	<u>(8,235,468)</u>
Business-type activities							
Utilities	2,587,676	1,685,620	-	2,207,756	-	1,305,700	1,305,700
Nursing home	120,053	308,817	-	-	-	188,764	188,764
Total business-type activities	<u>2,707,729</u>	<u>1,994,437</u>	<u>-</u>	<u>2,207,756</u>	<u>-</u>	<u>1,494,464</u>	<u>1,494,464</u>
Total government	<u>\$ 11,131,781</u>	<u>\$ 2,082,740</u>	<u>\$ 100,282</u>	<u>\$ 2,207,756</u>	<u>(8,235,468)</u>	<u>1,494,464</u>	<u>(6,741,004)</u>
General revenues							
Taxes							
Property					6,929,557	-	6,929,557
Sales					1,910,601	-	1,910,601
Intergovernmental					722,187	-	722,187
Interest income					30,954	54,139	85,093
Licenses and permits					463,422	-	463,422
Transfers					(1,586,127)	1,586,127	-
Miscellaneous					343,205	140,876	484,081
Total general revenues					<u>8,813,799</u>	<u>1,781,142</u>	<u>10,594,941</u>
Change in net position					578,331	3,275,606	3,853,937
Net Position - beginning of year					7,637,821	8,932,165	16,569,986
Prior period adjustment (full accrual conversion)					(672,515)	-	(672,515)
Net Position - beginning of year, as restated					<u>6,965,306</u>	<u>8,932,165</u>	<u>15,897,471</u>
Net Position - end of year					<u>\$ 7,543,637</u>	<u>\$ 12,207,771</u>	<u>\$ 19,751,408</u>

See notes to basic financial statements.

City of Valley, Nebraska
Balance Sheet - Governmental Funds
September 30, 2024

	General	Bond	Sales Tax	TIF	Keno	Total Governmental Funds
Assets						
Cash and investments	\$ 624,133	\$ 457,062	\$ 5,326,944	\$ 1,000	\$ 337,960	\$ 6,747,099
Cash with County Treasurer	57,891	8,048	-	71,403	-	137,342
Taxes receivable	101,434	10,742	325,308	-	-	437,484
Due from other funds	60,319	-	-	-	-	60,319
Total assets	\$ 843,777	\$ 475,852	\$ 5,652,252	\$ 72,403	\$ 337,960	\$ 7,382,244
Liabilities						
Accounts payable	\$ 216,005	\$ -	\$ -	\$ -	\$ -	\$ 216,005
Accrued wages payable	78,811	-	-	-	-	78,811
Total liabilities	294,816	-	-	-	-	294,816
Deferred Inflows of Resources						
Unavailable revenue - taxes receivable	18,868	-	-	-	-	18,868
Fund Balances						
Restricted for						
Debt service	-	475,852	-	72,403	-	548,255
Community betterment	-	-	-	-	337,960	337,960
Community development	-	-	5,652,252	-	-	5,652,252
Unassigned	530,093	-	-	-	-	530,093
Total fund balances	530,093	475,852	5,652,252	72,403	337,960	7,068,560
Total liabilities, deferred inflows of resources, and fund balances	\$ 843,777	\$ 475,852	\$ 5,652,252	\$ 72,403	\$ 337,960	\$ 7,382,244

Reconciliation of the Balance Sheet - Governmental Funds to the Statement of Net Position

Total fund balance - governmental funds	\$ 7,068,560
Capital assets used in governmental activities are not financial resources and, therefore, are not reported as assets in governmental funds.	3,721,378
Deferred inflows of resources for unavailable revenues not available to pay for current period expenditures.	18,868
Long-term liabilities, including bonds payable and related interest payable, are not due and payable in the current period and; therefore, are not reported as liabilities in the funds. Long-term liabilities at year-end consists of:	
Accrued interest payable	(10,778)
Lease liabilities	(334,391)
Bonds payable	<u>(2,920,000)</u>
Total net position - governmental activities	<u>\$ 7,543,637</u>

See notes to basic financial statements.

City of Valley, Nebraska
Statement of Revenues, Expenditures, and
Changes in Fund Balances - Governmental Funds
Year Ended September 30, 2024

	General	Bond	Sales Tax	TIF	Keno	Total Governmental
Revenues						
Taxes	\$ 2,125,695	\$ 395,721	\$ 1,910,601	\$ 4,385,562	\$ -	\$ 8,817,578
Special assessments	3,711	-	-	-	-	3,711
Licenses and permits	463,422	-	-	-	-	463,422
Intergovernmental	722,187	-	-	-	-	722,187
Charges for services	88,303	-	-	-	-	88,303
Grant income	26,003	-	-	-	-	26,003
Keno	-	-	-	-	101,575	101,575
Interest income	14,086	8,009	-	1,065	7,794	30,954
Other	198,627	-	-	-	-	198,627
Total revenues	<u>3,642,034</u>	<u>403,730</u>	<u>1,910,601</u>	<u>4,386,627</u>	<u>109,369</u>	<u>10,452,360</u>
Expenditures						
General government	1,285,633	1,101	-	-	-	1,286,734
Public health and safety	919,138	-	-	-	-	919,138
Culture and recreation	239,523	-	-	-	-	239,523
Public works	2,555,215	-	-	-	-	2,555,215
Community development	-	-	-	-	14,865	14,865
Debt service						
Principal	-	370,000	-	-	-	370,000
Interest	-	43,146	-	-	-	43,146
Total expenditures	<u>4,999,509</u>	<u>414,247</u>	<u>-</u>	<u>-</u>	<u>14,865</u>	<u>5,428,621</u>
Excess (deficiency) of revenues over (under) expenditures	<u>(1,357,475)</u>	<u>(10,517)</u>	<u>1,910,601</u>	<u>4,386,627</u>	<u>94,503</u>	<u>5,023,739</u>
Other Financing Sources (Uses)						
Proceeds from sale of property	74,279	-	-	-	-	74,279
Tax increment financing	-	-	-	(4,353,191)	-	(4,353,191)
Transfer from other funds	193,213	-	-	-	3,910	197,123
Transfer to other funds	(11,969)	(1,723,058)	-	(48,223)	-	(1,783,250)
Total other financing sources (uses)	<u>255,523</u>	<u>(1,723,058)</u>	<u>-</u>	<u>(4,401,414)</u>	<u>3,910</u>	<u>(5,865,039)</u>
Net change in fund balances	(1,101,952)	(1,733,575)	1,910,601	(14,787)	98,413	(841,300)
Fund balances, beginning of year	1,712,298	2,209,427	3,389,359	87,190	239,547	7,637,821
Prior period adjustment	(80,253)	-	352,292	-	-	272,039
Fund balance - beginning of year, as restated	<u>1,632,045</u>	<u>2,209,427</u>	<u>3,741,651</u>	<u>87,190</u>	<u>239,547</u>	<u>7,909,860</u>
Fund balances, end of year	<u>\$ 530,093</u>	<u>\$ 475,852</u>	<u>\$ 5,652,252</u>	<u>\$ 72,403</u>	<u>\$ 337,960</u>	<u>\$ 7,068,560</u>
Reconciliation of the Statement of Revenues, Expenditures, and Changes in Fund Balances - Governmental Funds to the Statement of Activities						
Total net change in fund balances - governmental funds						\$ (841,300)
Capital outlays are reported in governmental funds as expenditures. However, in the Statement of Activities, the cost of those assets is allocated over their estimated useful lives as depreciation and amortization expense. This is the amount by which capitalized capital outlay (\$1,336,338) exceeded depreciation and amortization expense (\$294,797).						1,041,541
Revenues in the Statement of Activities that do not provide current financial resources are not reported as revenues in the funds.						18,868
Repayment of bond principal is an expenditure in the governmental funds, but the repayment reduces long-term liabilities in the Statement of Net Position, including the change in accrued interest payable not recognized in the fund financial statements.						<u>359,222</u>
Change in net position of governmental activities						<u>\$ 578,331</u>

City of Valley, Nebraska
Statement of Net Position - Proprietary Funds
September 30, 2024

	<u>Utilities</u>	<u>Nursing Home</u>	<u>Total</u>
Assets			
Current assets			
Cash and cash equivalents	\$ 4,498,709	\$ 992,775	\$ 5,491,484
Grants receivable	504,754	-	504,754
Utility billing receivables	26,989	-	26,989
Lease receivable - current portion	-	246,144	246,144
Interest receivable	-	4,234	4,234
Total current assets	<u>5,030,452</u>	<u>1,243,153</u>	<u>6,273,605</u>
Noncurrent assets			
Land	4,000	-	4,000
Buildings	371,400	569,640	941,040
Infrastructure and Improvements	18,987,745	2,072,684	21,060,429
Equipment and furniture	392,038	16,783	408,821
Accumulated depreciation	(8,362,133)	(1,151,900)	(9,514,033)
Construction in progress	699,179	-	699,179
Net property, plant and equipment	<u>12,092,229</u>	<u>1,507,207</u>	<u>13,599,436</u>
Lease receivable - non-current portion	-	1,094,430	1,094,430
Total assets	<u>\$ 17,122,681</u>	<u>\$ 3,844,790</u>	<u>\$ 20,967,471</u>
Liabilities and Net Position			
Current liabilities			
Accounts payable	\$ 26,636	\$ -	\$ 26,636
Accrued expenses	35,787	-	35,787
Customer deposits	63,474	-	63,474
Due to other funds	60,319	-	60,319
Current portion of noncurrent liabilities	583,555	81,671	665,226
Total current liabilities	<u>769,771</u>	<u>81,671</u>	<u>851,442</u>
Noncurrent liabilities			
Bonds and notes payable, net of current portion	5,671,588	979,206	6,650,794
Deferred Inflows of Resources			
Lease receivable	-	1,257,464	1,257,464
Net Position			
Net investment in capital assets	5,837,086	446,330	6,283,416
Unrestricted	4,844,236	1,080,119	5,924,355
Total net position	<u>10,681,322</u>	<u>1,526,449</u>	<u>12,207,771</u>
Total liabilities and net position	<u>\$ 17,122,681</u>	<u>\$ 3,844,790</u>	<u>\$ 20,967,471</u>

City of Valley, Nebraska
Statement of Revenues,
Expenses and Changes in Net Position
Proprietary Funds
Year Ended September 30, 2024

	Utilities	Nursing Home	Total
Operating Revenues			
Metered sales	\$ 1,495,939	\$ -	\$ 1,495,939
Connection fees	153,500	-	153,500
Assessments	36,181	-	36,181
Rent	-	308,817	308,817
Miscellaneous income	116,900	23,976	140,876
Total operating revenues	<u>1,802,520</u>	<u>332,793</u>	<u>2,135,313</u>
Operating Expenses			
Salaries and benefits	50,589	-	50,589
Supplies	183,091	-	183,091
People service contract	439,800	-	439,800
Fremont Department of Utilities contract	589,778	-	589,778
Insurance	34,019	-	34,019
Utilities	109,360	-	109,360
Repairs and maintenance	422,737	-	422,737
Professional fees	16,482	419	16,901
Miscellaneous	117,422	-	117,422
Depreciation and amortization	499,741	53,458	553,199
Total operating expenses	<u>2,463,019</u>	<u>53,877</u>	<u>2,516,896</u>
Operating Income (loss)	<u>(660,499)</u>	<u>278,916</u>	<u>(381,583)</u>
Non-operating Revenues (expenses)			
Grant income	2,207,756	-	2,207,756
Interest income	54,139	-	54,139
Interest expense	(124,657)	(66,176)	(190,833)
Transfer from other funds	1,574,202	11,925	1,586,127
Total non-operating revenues (expenses)	<u>3,711,440</u>	<u>(54,251)</u>	<u>3,657,189</u>
Change in net position	3,050,941	224,665	3,275,606
Net position - beginning of year	<u>7,630,381</u>	<u>1,301,784</u>	<u>8,932,165</u>
Net position - end of year	<u>\$ 10,681,322</u>	<u>\$ 1,526,449</u>	<u>\$ 12,207,771</u>

City of Valley, Nebraska
Statement of Cash Flows
Proprietary Funds
Year Ended September 30, 2024

	<u>Utilities</u>	<u>Nursing Home</u>	<u>Total</u>
Cash Flows - Operating Activities			
Cash receipts from customers	\$ 1,818,065	\$ -	\$ 1,818,065
Other operating receipts	116,900	332,793	449,693
Cash payments to employees for services	(59,181)	-	(59,181)
Cash payments to suppliers for goods and services	<u>(2,519,743)</u>	<u>(419)</u>	<u>(2,520,162)</u>
Net cash flows - operating activities	<u>(643,959)</u>	<u>332,374</u>	<u>(311,585)</u>
Cash Flows - Noncapital Financing Activities			
Interfund activity	<u>(123,515)</u>	<u>11,925</u>	<u>(111,590)</u>
Cash Flows - Capital and Related Financing Activities			
Grant income	2,438,599	-	2,438,599
Acquisition of capital assets	(2,259,781)	-	(2,259,781)
Lease receivable activity	-	(18,576)	(18,576)
Principal payment on bonds and notes payable	(450,022)	(104,893)	(554,915)
Interest and fiscal fees paid on debt	<u>(90,147)</u>	<u>(66,899)</u>	<u>(157,046)</u>
Net cash flows - capital and related financing activities	<u>(361,351)</u>	<u>(190,368)</u>	<u>(551,719)</u>
Cash Flows - Investing Activities			
Interest on investments	<u>54,139</u>	<u>-</u>	<u>54,139</u>
Net change in cash and cash equivalents	(1,074,686)	153,931	(920,755)
Cash and cash equivalents - beginning of year	<u>5,573,395</u>	<u>838,844</u>	<u>6,412,239</u>
Cash and cash equivalents - end of year	<u>\$ 4,498,709</u>	<u>\$ 992,775</u>	<u>\$ 5,491,484</u>
Reconciliation of Change in Net Assets to Net Cash Flows - Operating Activities			
Operating income (loss)	\$ (660,499)	\$ 278,916	\$ (381,583)
Adjustments to reconcile operating income (loss) to net cash flows - operating activities			
Depreciation and amortization	499,741	53,458	553,199
Change in receivables	115,679	-	115,679
Change in payables and accrued expenses	<u>(598,880)</u>	<u>-</u>	<u>(598,880)</u>
Net cash flows - operating activities	<u>\$ (643,959)</u>	<u>\$ 332,374</u>	<u>\$ (311,585)</u>

City of Valley, Nebraska
Notes to Basic Financial Statements

NOTE 1 - SUMMARY OF SIGNIFICANT ACCOUNTING POLICIES

A. Introduction

The financial statements of the City of Valley, Nebraska (City) are prepared in accordance with generally accepted accounting principles (GAAP). The City's reporting entity applies all relevant Governmental Accounting Standards Board (GASB) pronouncements.

The accounting and reporting framework and the more significant accounting principles and practices of the City are discussed in the subsequent section of this Note. The remainder of the Notes are organized to provide explanations, including required disclosures, of the City's financial activities for the fiscal year ended September 30, 2024.

The City operates under a Council-Mayor form of government and provides the following services: streets, water, sanitary sewer, culture-recreation, public improvements, planning and zoning, and general administrative services.

B. Financial Reporting Entity

These financial statements present the financial statements of the City as the primary government. In determining its reporting entity, the City has considered all potential component units for which it is financially accountable, including other organizations which are fiscally dependent on the City, or the significance of their relationship with the City are such that exclusion would make the financial statements misleading or incomplete. The GASB has set forth criteria to be considered in determining financial accountability, which was used in making this evaluation. The City has no potential component units to include in its reporting entity.

C. Basis of Presentation

1.a. Government-Wide Financial Statements

The Statement of Net Position and Statement of Activities present information about the reporting government as a whole. They include all funds of the reporting entity except for fiduciary funds. The statements distinguish between governmental and business-type activities. Governmental activities generally are financed through taxes, intergovernmental revenues, and other nonexchange revenues. Business-type activities are financed in whole or in part by fees charged to external parties for goods or services.

1.b. Fund Financial Statements

Fund financial statements of the reporting entity are organized into funds, each of which is considered to be a separate accounting entity. Each fund is accounted for by providing a separate set of self-balancing accounts. Funds are organized into two major categories: governmental and proprietary. An emphasis is placed on major funds within the governmental and proprietary categories. In addition to the City's funds meeting the required criteria, the City's management has designated all remaining funds to be presented as major funds for financial reporting purposes.

2. Measurement Focus and Basis of Accounting

Measurement focus is a term used to describe "which" transactions are recorded within the various financial statements. Basis of accounting refers to "when" transactions are recorded regardless of measurement focus applied.

City of Valley, Nebraska
Notes to Basic Financial Statements

NOTE 1 - SUMMARY OF SIGNIFICANT ACCOUNTING POLICIES (CONTINUED)

C. Basis of Presentation (Continued)

2. Measurement Focus and Basis of Accounting (Continued)

The government-wide and proprietary fund financial statements are prepared using the economic resources measurement focus and the accrual basis of accounting. With this measurement focus, all assets and all liabilities associated with their operation are included on the financial statements. The proprietary funds are used to account for those activities that are operated in a manner similar to those found in the private sector, where the intent of the governing body is that the costs (expenses) including depreciation, of providing goods and services to the general public on a continuing basis be financed or recovered primarily through user charges.

Governmental fund financial statements are prepared using the current financial resources measurement focus and the modified accrual basis of accounting. Under the modified accrual basis of accounting, revenues are recognized when measurable and available. Measurable means the amount of the transaction can be determined. Available means collectible within the current period or within 60 days after year end. Expenditures are recorded when the related fund liability is incurred, except for debt service expenditures and other certain long-term obligations, which are reported as expenditures in the year due.

Proprietary funds distinguish operating revenues and expenses from nonoperating items. Operating revenues and expenses generally result from providing services and producing and delivering goods in connection with a proprietary fund's principal ongoing operations. The principal operating revenues of the enterprise funds are charges to customers for goods and services. Operating expenses include the cost of sales and service, administrative expenses, and depreciation of capital assets. All revenues and expenses not meeting this definition are reported as nonoperating revenues and expenses.

3. Use of Estimates

The preparation of financial statements in conformity with accounting principles generally accepted in the United States of America requires management to make estimates and assumptions that affect the reported amounts of assets, liabilities and deferred inflows/outflows of resources and disclosure of contingent assets and liabilities at the date of the financial statements and the reported amounts of revenues and expenses during the reporting period. Actual results could differ from those estimates.

4. Fund Types and Major Funds

Governmental funds are those through which most general governmental functions of the City are financed. The City reports the following major governmental funds:

General Fund - This fund is the general operating fund of the City. It is used to account for all financial resources except those required to be accounted for in another fund.

Bond Fund - This fund is used to account for the accumulation of resources for, and the payment of, general long-term debt principal, interest, and related costs.

City of Valley, Nebraska
Notes to Basic Financial Statements

NOTE 1 - SUMMARY OF SIGNIFICANT ACCOUNTING POLICIES (CONTINUED)

C. Basis of Presentation (Continued)

4. Fund Types and Major Funds (Continued)

Sales Tax Fund - This fund is used to account for the proceeds of specific sales tax receipts from the State of Nebraska and the disbursement of those receipts to the other City Funds. Sales tax collections are to be used for water and wastewater improvements.

Keno Fund - This fund is used to account for the proceeds of Keno funds from the local operator and disbursements are legally restricted for City Improvements/Betterments.

TIF Fund - This fund is used to account for the receipt of property taxes collected on the properties covered by the TIF agreements and the disbursement of the taxes collected.

Proprietary funds are used to account for the City's ongoing organizations and activities that are similar to those often found in the private sector. The City reports the following major proprietary funds:

Utility Fund - This fund is used to account for the operations and capital needs to provide treated water, and wastewater collection and treatment to customers within the City.

Nursing Home Fund - This fund is used to account for the receipt of rental payments of the nursing home.

D. Assets, Liabilities, Deferred Outflows/Inflows of Resources and Net Position/Fund Balance

1. Net Position Flow Assumption

Net position is required to be classified into three components - invested in capital assets, net of related debt, restricted and unrestricted. These classifications are defined as follows:

- a. Restricted - This component of net position consists of restrictions placed on net position use through external constraints imposed by creditors (such as debt covenants), contributors, or law or regulations of other governments, or constraints imposed by law through constitutional provisions or enabling legislation.
- b. Unrestricted - This component consists of net position that does not meet the definition of "restricted" or "invested in capital assets, net of related debt."

Sometimes the City will fund outlays for a particular purpose from both restricted and unrestricted resources. In order to calculate the amounts to report as restricted net position and unrestricted net position in proprietary fund financial statements, a flow assumption must be made about the order in which the resources are considered to be applied. It is the City's policy to use restricted resources first and the unrestricted resources as they are needed.

City of Valley, Nebraska
Notes to Basic Financial Statements

NOTE 1 - SUMMARY OF SIGNIFICANT ACCOUNTING POLICIES (CONTINUED)

**D. Assets, Liabilities, Deferred Outflows/Inflows of Resources and Net Position/Fund Balance
(Continued)**

2. Fund Balance Flow Assumptions

Governmental fund equity is reported as fund balance within each respective fund. For governmental funds, the fund balance is divided into five classifications based primarily on the extent to which the City is bound to observe constraints imposed upon the use of the resources in the governmental funds. The classifications are as follows:

- a. Non-Spendable - Amounts that cannot be spent either because they are not in spendable form or because they are legally or contractually required to be maintained intact.
- b. Restricted - Amounts that can be spent only for specific purposes because of the City Code, state or federal laws or externally imposed conditions by grantors or creditors.
- c. Committed - Amounts that can be used only for specific purposes determined by a formal action by the City Council through an ordinance or resolution.
- d. Assigned - Amounts that are designated by the Mayor for specific purposes but are not spendable until a budget ordinance is passed by the City Council.
- e. Unassigned - All amounts not included in other spendable classifications.

Sometimes the City will fund outlays for a particular purpose from both restricted and unrestricted resources (the total of committed, assigned and unassigned fund balance). In order to calculate the amounts to report for each category of fund balance in the governmental fund financial statements a flow assumption must be made about the order in which the resources are considered to be applied. It is the City's policy to consider restricted fund balance to have been depleted before using any of the components of unrestricted fund balance. Further, when the components of unrestricted fund balance can be used for the same purpose, committed fund balance is depleted first, followed by assigned fund balance. Unassigned fund balance is applied last.

3. Cash and Investments

For the purpose of the Statement of Net Position and Balance Sheet, "cash and cash equivalents" include all demand accounts and savings accounts. For the purpose of proprietary fund Statement of Cash Flows, "cash and cash equivalents" include all cash on hand, demand accounts, savings accounts, and equity in pooled cash which has an original maturity of three months or less. The County Treasurer's cash represents revenues collected not yet remitted to the City.

4. Receivables

Receivables consist of all revenues earned at year end and not yet received. Allowances for uncollectible accounts receivable are based upon historical trends and the periodic aging of accounts receivable. Major receivables balances for the governmental activities include property taxes and sales taxes. Utility accounts receivable are ordinarily due 21 days after the issuance of the invoice. Delinquent receivables are written off based on individual credit evaluation and specific circumstances of the customer.

Notes to Basic Financial Statements

NOTE 1 - SUMMARY OF SIGNIFICANT ACCOUNTING POLICIES (CONTINUED)

D. Assets, Liabilities, Deferred Outflows/Inflows of Resources and Net Position/Fund Balance (Continued)

5. Capital Assets

The accounting treatment over property, plant, and equipment (capital assets) depends on whether the assets are used in governmental fund operations or proprietary fund operations and whether they are reported in the government-wide or fund financial statements.

In the government-wide financial statements, capital assets are capitalized and reported on the Statement of Net Position. The City has a \$2,500 capitalization threshold. All capital assets are valued at historical cost or estimated historical cost if actual is unavailable, except for donated capital assets, which are recorded at their estimated acquisition value at the date of donation. The City has elected the modified approach for reporting infrastructure.

Capital assets are depreciated using the straight-line method. When capital assets are disposed, the cost and applicable accumulated depreciation are removed from the respective accounts, and the resulting gain or loss is recorded in operations.

Estimated useful lives for depreciable assets are as follows:

Buildings	15 - 40 years
Improvements and infrastructure	7 - 50 years
Equipment and furniture	4 - 20 years
Automobiles	4 - 10 years

In the fund financial statements, capital assets used in governmental fund operations are accounted for as capital outlay expenditures of the governmental fund upon acquisition. Capital assets used in proprietary fund operations are accounted for the same as in the government-wide statements.

6. Long-Term Debt

The accounting treatment of long-term debt depends on whether the proceeds are used in governmental fund operations or proprietary fund operations and whether they are reported in the government-wide or fund financial statements.

- Government-Wide Statements - All long-term debt to be repaid from governmental and business-type resources is reported as liabilities in government-wide statements. The long-term debt consists primarily of notes payable.
- Fund Financial Statements - Long-term debt for governmental funds is not reported as liabilities in the fund financial statements. The debt proceeds are reported as other financing sources and payment of principal and interest reported as expenditures. The accounting for proprietary funds is the same in the fund financial statements as it is in the government-wide statements.

City of Valley, Nebraska
Notes to Basic Financial Statements

NOTE 1 - SUMMARY OF SIGNIFICANT ACCOUNTING POLICIES (CONTINUED)

D. Assets, Liabilities, Deferred Outflows/Inflows of Resources and Net Position/Fund Balance (Continued)

7. Compensated Absences

The City's policies regarding vacation time permit employees to accumulate earned but unused vacation leave. The obligation for these compensated absences is recorded as accrued liabilities in the government-wide statements. In the fund financial statements, governmental funds report only the current compensated absence liability payable from expendable available financial resources, while the proprietary funds report the total liability.

8. Deferred Inflows of Resources

In addition to liabilities, the statement of net position and fund financial statements often report a separate section for deferred inflows of resources. This separate category represents an acquisition of net assets that applies to a future period(s) and so will not be recognized as an inflow of resources (revenue) until that time. Such amounts related to the lease receivable is reported in both the government-wide and proprietary funds statements.

E. Revenues, Expenditures and Expenses

1. Property Taxes

The tax levy for the City is certified by the County Board each year. Real estate taxes are due and attach as an enforceable lien on December 31 following the levy date. The first half of real estate taxes becomes delinquent on April 1 and the second half becomes delinquent August 1 following the levy date. Delinquent taxes bear interest at a 14% annual rate. Property taxes are collected by the County Treasurer and are periodically remitted to the City. The tax rate to finance governmental services other than debt service for the year ended September 30, 2024, was \$0.31 per \$100 of assessed valuation and the debt service requirement was \$0.06 per \$100 of assessed valuation. The assessed valuation of real property in the City for the 2023-2024 tax year was approximately \$700 million.

2. Expenditures/Expenses

In the fund financial statements, governmental fund expenditures are classified by character and function while proprietary fund expenditures are classified between operating and non-operating.

NOTE 2 - COMPLIANCE AND ACCOUNTABILITY

A. Interfund Transfers

Permanent reallocation of resources between funds of the reporting entity is classified as transfers.

B. Budgetary Information

An appropriated budget is adopted each fiscal year for the General, Special Revenue, Debt Service, and Utility Funds on the cash basis of accounting which is a comprehensive basis of accounting other than generally accepted accounting principles in the United States of America.

City of Valley, Nebraska
Notes to Basic Financial Statements

NOTE 2 - COMPLIANCE AND ACCOUNTABILITY (CONTINUED)

B. Budgetary Information (Continued)

The City follows these procedures in establishing the budgetary data reflected in the financial statements:

1. The City Administrator submits to the Mayor and City Council a proposed operating budget for the fiscal year commencing October 1. The operating budget includes proposed expenditures and the means of financing them.
2. Public hearings are conducted to obtain taxpayer comments.
3. Prior to September 30, the budget is legally enacted through passage of an ordinance and filed with the appropriate governmental entities and agencies.

The City Council adopts the budget on a per-fund basis and budgetary control is exercised at the fund level. The legal level of budgetary control is by fund type. Any revisions that alter the total expenditures of any fund must be approved by the City Council.

An encumbrance system is not used by the City and all appropriations lapse at year-end.

The City complied with its overall adopted budget for the year ended September 30, 2024.

NOTE 3 - DEPOSITS

Deposit risks include:

Custodial Credit Risk: The risk that in the event of the failure of a bank or other counterparty, the City will not be able to recover the value of its deposits or collateral securities in the possession of a third party.

Credit Risk: The risk that a bank or other counterparty defaults on its principal and/or interest payments owed to the City.

Interest Rate Risk: The risk that the value of deposits will decrease as a result of a rise in interest rates.

The City has not adopted a specific risk management policy for deposits but does require all deposits and investments be in compliance with the provisions of state statutes. Statutes authorize the City to invest in time deposits at banks selected as depositories of City funds, direct debt securities of the United States Government, and certain government agency bonds.

Cash is stated at cost, which approximates fair value. The City's cash deposits, including demand deposits and certificates of deposit, are insured by the Federal Deposit Insurance Corporation and securities held in safekeeping pledged to the entity where the security is held. At September 30, 2024, the City's deposits at banks were \$12,269,631; of which \$250,000 per registered depositor was covered by federal depository insurance or pledged security, and \$12,269,631 was insured by the Nebraska Bankers Insurance and Service Company.

City of Valley, Nebraska
Notes to Basic Financial Statements

NOTE 3 - DEPOSITS (CONTINUED)

Cash with the Douglas County Treasurer of \$137,342 was covered by collateral held by the County or was invested in U.S. Government Securities held by the County's agent.

NOTE 4 - FAIR VALUE MEASUREMENTS

The City categorizes its fair value measurements within the fair value hierarchy established by generally accepted accounting principles. The hierarchy is based on the valuation inputs used to measure fair value of the assets.

Assets and liabilities are classified into one of the following categories:

- Level 1: Quoted market prices in active markets for identical assets or liabilities.
- Level 2: Observable market-based inputs or unobservable inputs that are corroborated by market data.
- Level 3: Unobservable inputs that are not corroborated by market data.

A financial instrument's categorization within the valuation hierarchy is based upon the lowest level of input that is significant to the fair value measurement. All of the City's certificates of deposits as of September 30, 2024, are categorized as Level 2 investments.

City of Valley, Nebraska
Notes to Basic Financial Statements

NOTE 5 - CAPITAL ASSETS

Capital asset activity for the year ended September 30, 2024, was as follows:

	Beginning Balance	Increases	Decreases	Ending Balance
Governmental activities				
Not being depreciated				
Land	\$ 300,000	\$ -	\$ -	\$ 300,000
Other capital assets				
Buildings	753,504	-	-	753,504
Improvement/infrastructure	1,526,451	1,114,405	-	2,640,856
Equipment and furniture	926,687	221,933	-	1,148,620
Leased assets	-	334,391	-	334,391
Less, accumulated depreciation	(1,161,196)	(294,797)	-	(1,455,993)
Subtotal	<u>2,045,446</u>	<u>1,375,932</u>	<u>-</u>	<u>3,421,378</u>
Net capital assets - governmental activities	<u>\$ 2,345,446</u>	<u>\$ 1,375,932</u>	<u>\$ -</u>	<u>\$ 3,721,378</u>
Business-type activities				
Not being depreciated				
Land	\$ 4,000	\$ -	\$ -	\$ 4,000
Construction in progress	2,338,836	2,111,503	(3,751,160)	699,179
Subtotal	<u>2,342,836</u>	<u>2,111,503</u>	<u>(3,751,160)</u>	<u>703,179</u>
Other capital assets				
Water Fund				
Buildings	371,400	-	-	371,400
Improvement/infrastructure	5,668,805	3,751,160	-	9,419,965
Equipment and furniture	127,327	14,192	-	141,519
Less, Accumulated Depreciation	(3,922,428)	(249,582)	-	(4,172,010)
Subtotal	<u>2,245,104</u>	<u>3,515,770</u>	<u>-</u>	<u>5,760,874</u>
Wastewater Fund				
Improvement/infrastructure	9,567,780	-	-	9,567,780
Equipment and furniture	116,433	134,086	-	250,519
Less, Accumulated Depreciation	(3,939,963)	(250,160)	-	(4,190,123)
Subtotal	<u>5,744,250</u>	<u>(116,074)</u>	<u>-</u>	<u>5,628,176</u>
Nursing Home				
Buildings	569,642	-	-	569,642
Improvement/infrastructure	2,072,682	-	-	2,072,682
Equipment and furniture	16,783	-	-	16,783
Less, Accumulated Depreciation	(1,098,442)	(53,458)	-	(1,151,900)
Subtotal	<u>1,560,665</u>	<u>(53,458)</u>	<u>-</u>	<u>1,507,207</u>
Net capital assets - business-type activities	<u>\$ 11,892,855</u>	<u>\$ 5,457,741</u>	<u>\$ (3,751,160)</u>	<u>\$ 13,599,436</u>

City of Valley, Nebraska
Notes to Basic Financial Statements

NOTE 6 - LONG-TERM LIABILITIES

General obligation bonds, issued by the City for various municipal improvements, are repaid with property taxes recorded in the Debt Service Fund. The City has pledged its full faith and credit as collateral for the general obligation bonds. The City has no debt outstanding subject to legal debt limitations. The City's borrowing capacity is restrained by maintaining the City's debt at a responsible level.

A. Bonds Payable

Specific changes in the individual governmental bond issues were as follows:

Issuance Date	Interest Rate	Maturity Date	Balance 9/30/23	Net Additions (Reductions)	Balance 9/30/24
September 15, 2015	0.65-2.35%	11/1/2023	\$ 55,000	\$ (55,000)	\$ -
November 15, 2019	1.35-2.05%	1/1/2032	335,000	(125,000)	210,000
July 13, 2021	0.25-1.15%	12/15/2029	565,000	(80,000)	485,000
July 13, 2021	0.30-2.05%	12/15/2041	2,335,000	(110,000)	2,225,000
Total			<u>\$ 3,290,000</u>	<u>\$ (370,000)</u>	<u>\$ 2,920,000</u>

Specific changes in the individual proprietary bond issues were as follows:

Issuance Date	Interest Rate	Maturity Date	Balance 9/30/23	Net Additions (Reductions)	Balance 9/30/24
Nursing Home					
July 15, 2014	6.00%	7/15/2034	\$ 1,137,802	\$ (76,925)	\$ 1,060,877
Utilities					
November 15, 2018	2.10-4.00%	12/15/2038	1,440,000	(80,000)	1,360,000
October 1, 2021	0.30-1.80%	12/15/2036	1,345,000	(95,000)	1,250,000
March 24, 2022	0.50-1.80%	6/15/2031	3,590,000	(275,000)	3,315,000
Total			<u>\$ 7,512,802</u>	<u>\$ (526,925)</u>	<u>\$ 6,985,877</u>

On September 15, 2015, the City issued General Obligation Refunding Bonds in the amount of \$460,000 for the purpose of refunding the Series 2010 bonds with an outstanding principal amount of \$450,000. The bonds had interest rates between 0.65-2.35% and a maturity date of November 1, 2023.

On November 15, 2019, the City issued General Obligation Various Purpose Refunding Bonds in the amount of \$760,000 for the purpose of refunding \$315,000 of General Obligation Bonds, Series 2012 originally issued by SID No. 196 and refunding \$435,000 General Obligation Bonds, Series 2014 originally issued by SID No. 254. The bonds have interest rates ranging from 1.35-2.05% and a maturity date of January 1, 2032.

On July 13, 2021 the City issued General Obligation Various Purpose Refunding Bonds (Series 2021A) in the amount of \$715,000 for the purpose of refunding the Series 2014 bonds. The bonds have interest rates ranging from 0.25-1.15% and a maturity date of December 15, 2029.

City of Valley, Nebraska
Notes to Basic Financial Statements

NOTE 6 - LONG-TERM LIABILITIES (CONTINUED)

A. Bonds Payable (Continued)

On July 13, 2021 the City issued General Obligation Bonds in the amount of \$2,445,000 for the purpose of improving streets within the City (Highway Allocation Fund Pledge Bonds). The bonds have interest rates ranging from 0.30-2.05% and maturity date of December 15, 2041.

On July 15, 2014 the City issued Nursing Home Revenue Bonds in the amount of \$1,620,000 for the purpose of the nursing home renovations. The bonds have an interest rate of 6% and maturity date of July 15, 2034.

On November 15, 2018 the City issued General Obligation Water Bonds in the amount of \$1,810,000 for the purpose of paying the costs of improvements to the existing water system. The bonds have interest rates ranging from 2.1% to 4.0% and maturity date of December 15, 2038.

On October 1, 2021 the City issued General Obligation Various Purpose Refunding Bonds (Series 2021B) in the amount of \$1,440,000 for the purpose of refunding the General Obligation Bonds (Series 2016) with an outstanding principal amount of \$1,390,000. The bonds have interest rates ranging from 0.3% to 1.8% and maturity date of December 15, 2036.

On March 24, 2022 the City issued General Obligation Various Purpose Refunding Bonds (Series 2022) in the amount of \$4,055,000 for the purpose of refunding the General Obligation Bonds (Series 2017) with an outstanding principal amount of \$3,930,000. The bonds have interest rates ranging from 0.5% to 1.8% and maturity date of June 15, 2031.

B. Annual Requirements on Bonds Payable

The annual debt service requirements to maturity for bonded debt as of September 30, 2024, are as follows:

<u>Year Ending September 30,</u>	<u>Governmental Activities</u>		
	<u>Principal</u>	<u>Interest</u>	<u>Total</u>
2025	\$ 215,000	\$ 40,208	\$ 255,208
2026	220,000	38,641	258,641
2027	220,000	36,806	256,806
2028	220,000	34,666	254,666
2029	225,000	32,195	257,195
2030-2042	1,820,000	208,763	2,028,763
Total	<u>\$ 2,920,000</u>	<u>\$ 391,279</u>	<u>\$ 3,311,279</u>

City of Valley, Nebraska
Notes to Basic Financial Statements

NOTE 6 - LONG-TERM LIABILITIES (CONTINUED)

B. Annual Requirements on Bonds Payable (Continued)

Year Ending September 30,	Business-Type Activities		
	Principal	Interest	Total
2025	\$ 636,671	\$ 174,269	\$ 810,940
2026	651,506	161,532	813,038
2027	576,655	145,033	721,688
2028	797,732	136,521	934,253
2029	828,760	119,512	948,272
2030-2039	3,494,553	388,869	3,883,422
Total	<u>\$ 6,985,877</u>	<u>\$ 1,125,736</u>	<u>\$ 8,111,613</u>

C. Leases

The City entered into lease agreements for public works department equipment which included an International truck and John Deere tractor mower. The outstanding principal balance of the leases as of September 30, 2024 totaled \$334,391. Payments of principal and interest will occur in the amount of \$85,054 each October 15 through fiscal year 2027 for the truck. For the mower, the annual principal and interest payments are made on March 31 in the amount of \$22,393 and will mature on March 31, 2029. Principal due in the fiscal year 2025 total \$93,603.

D. Note Payable

The City has entered into a note payable with the Nebraska Department of Environmental Quality (NDEQ) for a loan of \$748,709 of which \$185,578 was forgiven leaving a remaining original balance due of \$562,131. The loan has an interest rate of 2% and maturity date of June 15, 2034. Principal paid on the loan during 2024 totaled \$27,992.

The following is a schedule of remaining principal and interest payments under the note as of September 30, 2024:

Year Ending September 30,	Note Payable - Utilities Enterprise Fund		
	Principal	Interest	Total
2025	\$ 28,555	\$ 6,460	\$ 35,015
2026	29,129	5,886	35,015
2027	29,714	5,301	35,015
2028	30,311	4,704	35,015
2029	30,921	4,094	35,015
2030-2035	181,513	11,072	192,585
Total	<u>\$ 330,143</u>	<u>\$ 37,517</u>	<u>\$ 367,660</u>

City of Valley, Nebraska
Notes to Basic Financial Statements

NOTE 7 - RETIREMENT PLAN CONTRIBUTIONS

Qualifying employees may contribute a percentage of their choice of gross wages to an individual retirement account, exclusive of overtime, and the City will match that contribution up to 6%. The City contributed \$134,189 to employee retirement accounts for the year ended September 30, 2024.

NOTE 8 - INTERFUND BALANCES AND TRANSACTIONS

During the course of operations, transactions occur between individual funds that may result in amounts owed between funds. Those that are related to goods and services transactions are classified as "due to and from other funds."

The City has the following interfund balances at September 30, 2024:

	<u>Receivable Fund</u>	<u>Payable Fund</u>
General Fund	\$ 60,553	\$ -
Utilities	-	60,553

Transfers are used to (a) move revenues from the fund that statute or budget requires to collect them to the fund that statute or budget requires to expend them, (b) move revenues from restricted funds to funds where the expenditures were incurred related to the restriction and to (c) use unrestricted revenues collected in the general fund to finance various programs accounted for in other funds in accordance with budgetary authorizations.

Transfers during the year ended September 30, 2024 were primarily related to debt service requirements and involved the Bond Fund and Utilities Fund.

NOTE 9 - RISK MANAGEMENT

The City is exposed to various risks of loss related to torts, theft, damage to, or destruction of assets, errors or omissions, injuries to employees or acts of God. These risks are transferred to independent insurance carriers and no self-insurance program is maintained by the City. City management believes adequate coverage exists for potential exposures as of September 30, 2024. Settled claims in the past three years have not exceeded the commercial coverages.

NOTE 10 - DESIGNATED REVENUES

The City has committed all proceeds from sales tax to be applied toward water and wastewater improvement projects.

NOTE 11 - COMMITMENTS AND CONTINGENCIES

The City has entered into a construction contract with an outstanding commitment as of September 30, 2024, of \$1,495,620 for the Park Phase I project.

City of Valley, Nebraska
Notes to Basic Financial Statements

NOTE 12 - ADJUSTMENTS TO AND RESTATEMENTS OF BEGINNING BALANCES

The fund financial statements for the governmental funds and the governmental activities portion of the government-wide statements were presented on the cash basis of accounting in previous year. For the year ended September 30, 2024, the City moved to reporting on a GAAP basis which includes modified accrual presentation for the governmental fund financial statements and full accrual for the governmental activities in the government-wide statements.

The increase to beginning fund balance of \$272,039 in the governmental funds statement of revenues, expenditures, and changes in fund balances relates to amounts for taxes receivable, accrued wages, accrued vacation, and accounts payable as of September 30, 2023.

In the government-wide statement of activities, the adjustment of \$672,515 also includes the impact of including the carrying value of capital assets and the balances of long-term liabilities for bonds and leases payable as of September 30, 2023.

NOTE 13 - LEASE RECEIVABLE

The City leases a healthcare facility to a third-party entity that operates the facility. The initial term of the lease is ten years. Monthly rental payments under the agreement are \$22,159 for the first three years, \$22,824 the fourth year, and an amount to be determined based on the increase in the rate of reimbursement from the Nebraska Medicaid Agency to skilled nursing facilities, as defined, for the remaining six years. The agreement contains two renewal options for 5-year terms each that are exercisable by the lessee. The annual expected rent amounts to be received to maturity for the lease receivable as of September 30, 2024 are as follows:

<u>Year Ended September 30,</u>	<u>Business-Type Activities</u>	
	<u>Principal</u>	<u>Interest</u>
2025	\$ 246,144	\$ 46,592
2025	264,578	36,946
2027	283,984	26,585
2028	304,420	15,470
2029	241,448	3,829
Total	<u>\$ 1,340,574</u>	<u>\$ 129,422</u>

NOTE 14 - SUBSEQUENT EVENTS

Management has evaluated subsequent events through May 15, 2025, the date on which the financial statements were available to be issued.

On October 17, 2024, in connection with the newly created City of Valley Leasing Corporation, issued Lease Rental Revenue Bonds (Series 2024) in the amount of \$1,860,000 for police station improvements. The bonds will mature on October 15, 2039 and include interest rates ranging from 3.75% to 4.55%.

On November 5, 2024, the City issued General Obligation Highway Allocation Fund Pledge Bonds (Series 2024) in the amount of \$1,585,000 to finance street projects. The bonds will mature on October 15, 2039 and include interest rates ranging from 3.6% to 4.4%.

DRAFT

SUPPLEMENTARY INFORMATION

City of Valley, Nebraska
Schedule of Revenues, Expenditures, and Changes in
Fund Balance - Budget and Actual
Governmental Funds (Excluding Debt Service Fund)
Year Ended September 30, 2024

	Initial and Final Budget	Actual	Variance
Revenues			
Taxes	\$ 6,608,811	\$ 8,425,568	\$ 1,816,757
Licenses and permits	523,200	463,422	(59,778)
Intergovernmental	537,290	722,187	184,897
Charges for services	115,500	88,303	(27,197)
Miscellaneous	714,749	198,627	(516,122)
Keno fees	84,000	101,575	17,575
Grant income	13,000	26,003	13,003
Interest income	7,950	22,945	14,995
Total revenues	<u>8,604,500</u>	<u>10,048,630</u>	<u>1,444,130</u>
Expenditures			
General government	3,585,873	1,285,633	(2,300,240)
Public health and safety	1,706,340	919,138	(787,202)
Culture and recreation	4,951,620	239,523	(4,712,097)
Public works	4,913,791	2,555,215	(2,358,576)
Community development	-	14,865	14,865
Total expenditures	<u>15,157,624</u>	<u>5,014,374</u>	<u>(10,143,250)</u>
Excess (deficiency) of revenues over expenditures	<u>(6,553,124)</u>	<u>5,034,256</u>	<u>11,587,380</u>
Other Financing Sources (Uses)			
Proceeds from sale of property	25,001	74,279	49,278
Tax increment financing	(2,800,000)	(4,353,191)	(1,553,191)
Transfers from other funds	9,150,000	197,123	(8,952,877)
Transfers to other funds	(610,000)	(60,192)	549,808
Total other financing sources (uses)	<u>5,765,001</u>	<u>(4,141,981)</u>	<u>(9,906,982)</u>
Change in fund balances	<u>\$ (788,123)</u>	892,275	<u>\$ 1,680,398</u>
Fund balances - beginning of year		5,428,394	
Prior period adjustment		272,039	
Fund balance - beginning of year, as restated		<u>5,700,433</u>	
Fund balances - end of year		<u>\$ 6,592,708</u>	

City of Valley, Nebraska
Schedule of Revenues, Expenditures, and Changes in
Fund Balance - Budget and Actual
Debt Service Fund
Year Ended September 30, 2024

	Initial and Final Budget	Actual	Variance
Revenues			
Taxes	\$ 413,646	\$ 395,721	\$ (17,925)
Interest income	8,000	8,009	9
Total revenues	<u>421,646</u>	<u>403,730</u>	<u>(17,916)</u>
Expenditures			
General government	2,000	1,101	(899)
Debt service			
Principal retirement	370,000	370,000	-
Interest	43,146	43,146	-
Total expenditures	<u>415,146</u>	<u>414,247</u>	<u>(899)</u>
Excess (deficiency) of revenues over expenditures	<u>6,500</u>	<u>(10,517)</u>	<u>(17,017)</u>
Other Financing Uses			
Transfers to other funds	-	(1,723,058)	(1,723,058)
Change in fund balance	<u>\$ 6,500</u>	<u>(1,733,575)</u>	<u>\$ (1,740,075)</u>
Fund balance - beginning of year		<u>2,209,427</u>	
Fund balance - end of year		<u>\$ 475,852</u>	

City of Valley, Nebraska
Schedule of Revenues, Expenditures, and Changes in
Fund Balance - Budget and Actual
Proprietary Funds
Year Ended September 30, 2024

	Initial and Final Budget	Actual - Budget Basis	Variance
Revenues			
Metered sales	\$ 1,500,000	\$ 1,495,939	\$ (4,061)
Connection fees	210,000	153,500	(56,500)
Assessments	6,000	36,181	30,181
Rent	282,000	308,817	26,817
Grant income	7,692,500	2,207,756	(5,484,744)
Miscellaneous income	153,400	195,015	41,615
Total revenues	<u>9,843,900</u>	<u>4,397,208</u>	<u>(5,446,692)</u>
Expenditures			
Personnel services	68,900	50,589	(18,311)
Supplies and other	285,250	217,110	(68,140)
Contracts	750,470	1,029,578	279,108
Repairs and maintenance	163,000	422,737	259,737
Utilities	75,000	109,360	34,360
Professional fees	70,000	16,901	(53,099)
Miscellaneous	114,600	117,422	2,822
Interest expense	206,755	224,620	17,865
Capital outlay	10,896,500	221,933	(10,674,567)
Debt principal	548,246	554,915	6,669
Depreciation and amortization	-	553,199	553,199
Total expenditures	<u>13,178,721</u>	<u>3,518,364</u>	<u>(9,660,357)</u>
Excess (deficiency) of revenues over (under) expenditures	<u>(3,334,821)</u>	<u>878,844</u>	<u>4,213,665</u>
Other Financing Sources			
Transfers from other funds	<u>610,000</u>	<u>1,586,127</u>	<u>976,127</u>
Change in fund balance	<u>\$ (2,724,821)</u>	<u>2,464,971</u>	<u>\$ 5,189,792</u>
Fund balance - beginning of year		8,932,165	
Accrual basis adjustments to reconcile		<u>810,635</u>	
Fund balance - end of year		<u>\$ 12,207,771</u>	

City of Valley, Nebraska
Notes to Budgetary Comparison Schedules
Year Ended September 30, 2024

NOTE A – BASIS OF PRESENTATION

The State of Nebraska prescribes that the City adopt a cash basis budget annually following the required public notice and hearing for all funds. The City's practice is to adopt its budget early to accommodate major tenants in their budgeting process. When final valuations are received, the City's board amends the budgeted property tax collections to adjust for any change.

NOTE B – BASIS OF ACCOUNTING

The City's budgetary process accounts for certain transactions on a basis other than accounting principles generally accepted in the United States of America (GAAP). The major differences between the budgetary basis and GAAP basis lie in the manner in which revenues and expenditures are recorded. Under the budgetary basis, revenues and expenditures are recognized on a cash basis. Utilizing the cash basis, revenues are recorded when received and expenditures are recorded when paid. Under the GAAP basis, revenues and expenditures are recorded on the modified accrual basis of accounting in the governmental fund statements and on the accrual basis in the government-wide statements.

DRAFT

City of Valley, Nebraska
Schedule of Expenditures of Federal Awards
For the Year Ended September 30, 2024

<u>Federal Grantor/Pass-Through Grantor/Program Title</u>	<u>Federal Assistance Listing Number</u>	<u>Pass-Through Entity Identifying Number</u>	<u>Total Federal Expenditures</u>
U.S. DEPARTMENT OF ENVIRONMENTAL PROTECTION			
Passed Through Nebraska Department of Environment & Energy: DWSRF Cluster: Safe Drinking Water State Revolving Funds	(1) 66.468	N/A	<u>\$ 2,219,506</u>
Total Expenditures of Federal Awards			<u>\$ 2,219,506</u>

(1) Major program tested

DRAFT

City of Valley, Nebraska
Notes to Schedule of Federal Expenditures of Awards
Year Ended September 30, 2024

NOTE A – BASIS OF PRESENTATION

The accompanying schedule of expenditures of federal awards includes the federal grant activity of the City of Valley, Nebraska and is presented on the accrual basis of accounting. The information in this schedule is presented in accordance with the requirements of Title 2 U.S. *Code of Federal Regulations* Part 200, *Uniform Administrative Requirements, Cost of Principles, and Audit Requirements for Federal Awards* (Uniform Guidance). Therefore, some amounts presented in this schedule may differ from amounts presented in or used in the preparation of the financial statements. The entity has elected not to use the 10% de minimis indirect cost rate as allowed under the Uniform Guidance.

NOTE B – TYPE A PROGRAM THRESHOLD

The threshold of Type A and Type B programs was \$750,000 for the year ended September 30, 2024.

NOTE C – MAJOR PROGRAM

<u>Federal Assistance Number</u>	<u>Program Name</u>
66.468	Safe Drinking Water State Revolving Funds

**INDEPENDENT AUDITORS' REPORT ON INTERNAL CONTROL OVER FINANCIAL REPORTING
AND ON COMPLIANCE AND OTHER MATTERS BASED ON AN AUDIT OF FINANCIAL
STATEMENTS PERFORMED IN ACCORDANCE WITH
GOVERNMENT AUDITING STANDARDS**

To the Honorable Mayor and Members of the City Council
City of Valley, Nebraska

We have audited, in accordance with the auditing standards generally accepted in the United States of America and the standards applicable to financial audits contained in the *Government Auditing Standards* issued by the Comptroller General of the United States, the financial statements of the governmental activities, the business-type activities and each major fund of the City of Valley, Nebraska (the City) as of and for the year ended September 30, 2024, and the related notes to the financial statements, which collectively comprise the City's basic financial statements, and have issued our report thereon dated May 15, 2025.

Report on Internal Control over Financial Reporting

In planning and performing our audit of the financial statements, we considered the City's internal control over financial reporting (internal control) to determine the audit procedures that are appropriate in the circumstances for the purpose of expressing our opinions on the financial statements, but not for the purpose of expressing an opinion on the effectiveness of the City's internal control. Accordingly, we do not express an opinion on the effectiveness of the City's internal control.

A deficiency in internal control exists when the design or operation of a control does not allow management or employees, in the normal course of performing their assigned functions, to prevent, or detect and correct misstatements on a timely basis. A *material weakness* is a deficiency, or combination of deficiencies, in internal control, such that there is a reasonable possibility that a material misstatement of the entity's financial statements will not be prevented, or detected and corrected on a timely basis. A *significant deficiency* is a deficiency, or combination of deficiencies, in internal control that is less severe than a material weakness, yet important enough to merit attention by those charged with governance.

Our consideration of internal control was for the limited purpose described in the first paragraph of this section and was not designed to identify all deficiencies in internal control that might be material weaknesses or significant deficiencies. Given these limitations, during our audit we did not identify any deficiencies in internal control that we consider to be material weaknesses. However, material weaknesses or significant deficiencies may exist that have not been identified.

Report on Compliance and Other Matters

As part of obtaining reasonable assurance about whether the City's financial statements are free from material misstatement, we performed tests of its compliance with certain provisions of laws, regulations, contracts, and grant agreements, noncompliance with which could have a direct and material effect on the determination of financial statement amounts. However, providing an opinion on compliance with those provisions was not an objective of our audit, and accordingly, we do not express such an opinion. The results of our tests disclosed no instances of noncompliance or other matters that are required to be reported under *Government Auditing Standards*.

Purpose of this Report

The purpose of this report is solely to describe the scope of our testing of internal control and compliance and the results of that testing, and not to provide an opinion on the effectiveness of the entity's internal control or on compliance. This report is an integral part of an audit performed in accordance with *Government Auditing Standards* in considering the entity's internal control and compliance. Accordingly, this communication is not suitable for any other purpose.

BLAND + ASSOCIATES, P.C.

Omaha, Nebraska
May 15, 2025

DRAFT

**INDEPENDENT AUDITORS' REPORT ON COMPLIANCE WITH REQUIREMENTS
THAT COULD HAVE A DIRECT AND MATERIAL EFFECT FOR THE MAJOR
PROGRAM AND INTERNAL CONTROL OVER
COMPLIANCE IN ACCORDANCE WITH UNIFORM GUIDANCE**

To the Honorable Mayor and Members of the City Council
City of Valley, Nebraska

Opinion on the Major Federal Program

We have audited the City of Valley, Nebraska's (the City) compliance with the types of compliance requirements described in the *OMB Compliance Supplement* that could have a direct and material effect on the City's major federal program for the year ended September 30, 2024. The City's major federal program is identified in the summary of audit results section of the accompanying schedule of findings and questioned costs.

In our opinion, the City complied, in all material respects, with the compliance requirements referred to above that could have a direct and material effect on its major federal program for the year ended September 30, 2024.

Basis for Opinion on the Major Federal Program

We conducted our audit of compliance in accordance with auditing standards generally accepted in the United States of America (GAAS); the standards applicable to financial audits contained in Government Auditing Standards issued by the Comptroller General of the United States (*Government Auditing Standards*); and the audit requirements of Title 2 U.S. *Code of Federal Regulations Part 200, Uniform Administrative Requirements, Cost Principles, and Audit Requirements for Federal Awards* (Uniform Guidance). Our responsibilities under those standards and the Uniform Guidance are further described in the Auditor's Responsibilities for the Audit of Compliance section of our report.

We are required to be independent of the City and to meet our other ethical responsibilities, in accordance with relevant ethical requirements relating to our audit. We believe that the audit evidence we have obtained is sufficient and appropriate to provide a basis for our opinion on compliance for the major federal program. Our audit does not provide a legal determination of the City's compliance with the compliance requirements referred to above.

Responsibilities of Management for Compliance

Management is responsible for compliance with the requirements referred to above and for the design, implementation, and maintenance of effective internal control over compliance with the requirements of laws, statutes, regulations, rules and provisions of contracts or grant agreements applicable to the City's federal program.

Auditor's Responsibilities for the Audit of Compliance

Our objectives are to obtain reasonable assurance about whether material noncompliance with the compliance requirements referred to above occurred, whether due to fraud or error, and express an opinion on the City's compliance based on our audit. Reasonable assurance is a high level of assurance but is not absolute assurance and therefore is not a guarantee that an audit conducted in accordance with GAAS, *Government Auditing Standards*, and the Uniform Guidance will always detect material noncompliance when it exists. The risk of not detecting material noncompliance resulting from fraud is higher than for that resulting from error, as fraud may involve collusion, forgery, intentional omissions, misrepresentations, or the override of internal control. Noncompliance with the compliance requirements referred to above is considered material, if there is a substantial likelihood that, individually or in the aggregate, it would influence the judgment made by a reasonable user of the report on compliance about the City's compliance with the requirements of each major federal program as a whole.

In performing an audit in accordance with GAAS, *Government Auditing Standards*, and the Uniform Guidance, we:

- Exercise professional judgment and maintain professional skepticism throughout the audit.
- Identify and assess the risks of material noncompliance, whether due to fraud or error, and design and perform audit procedures responsive to those risks. Such procedures include examining, on a test basis, evidence regarding the City's compliance with the compliance requirements referred to above and performing such other procedures as we considered necessary in the circumstances.
- Obtain an understanding of the City's internal control over compliance relevant to the audit in order to design audit procedures that are appropriate in the circumstances and to test and report on internal control over compliance in accordance with the Uniform Guidance, but not for the purpose of expressing an opinion on the effectiveness of the City's internal control over compliance. Accordingly, no such opinion is expressed.

We are required to communicate with those charged with governance regarding, among other matters, the planned scope and timing of the audit and any significant deficiencies and material weaknesses in internal control over compliance that we identified during the audit.

Report on Internal Control Over Compliance

A *deficiency in internal control over compliance* exists when the design or operation of a control over compliance does not allow management or employees, in the normal course of performing their assigned functions, to prevent, or detect and correct, noncompliance with a type of compliance requirement of a federal program on a timely basis. A *material weakness in internal control over compliance* is a deficiency, or a combination of deficiencies, in internal control over compliance, such that there is a reasonable possibility that material noncompliance with a type of compliance requirement of a federal program will not be prevented, or detected and corrected, on a timely basis. A *significant deficiency in internal control over compliance* is a deficiency, or a combination of deficiencies, in internal control over compliance with a type of compliance requirement of a federal program that is less severe than a material weakness in internal control over compliance, yet important enough to merit attention by those charged with governance.

Our consideration of internal control over compliance was for the limited purpose described in the Auditor's Responsibilities for the Audit of Compliance section above and was not designed to identify all deficiencies in internal control over compliance that might be material weaknesses or significant deficiencies in internal control over compliance. Given these limitations, during our audit we did not identify any deficiencies in internal control over compliance that we consider to be material weaknesses, as defined above. However, material weaknesses or significant deficiencies in internal control over compliance may exist that were not identified.

Our audit was not designed for the purpose of expressing an opinion on the effectiveness of internal control over compliance. Accordingly, no such opinion is expressed.

The purpose of this report on internal control over compliance is solely to describe the scope of our testing of internal control over compliance and the results of that testing based on the requirements of the Uniform Guidance. Accordingly, this report is not suitable for any other purpose.

BLAND + ASSOCIATES, P.C.

Omaha, Nebraska
May 15, 2025

**City of Valley, Nebraska
Schedule of Findings and Questioned Costs
Year Ended September 30, 2024**

A. SUMMARY OF AUDIT RESULTS

FINANCIAL STATEMENTS AUDIT

Type of auditors' report issued:

Unmodified

Internal control over financial reporting:

Material weakness(es) identified?:

Yes _____ No X

Significant deficiency(ies) identified that are not considered to be material weakness(es)?:

Yes _____ No X

Noncompliance material to the financial statements noted?:

Yes _____ No X

MAJOR FEDERAL AWARDS PROGRAM AUDIT

Internal control over major federal program:

Material weakness(es) identified?:

Yes _____ No X

Significant deficiency(ies) identified?:

Yes _____ No X

Type of auditors' report issued on compliance for major program:

Unmodified

Any audit findings disclosed that are required to be reported in accordance with 2 Assistance Listing Number 200.516(a)?:

Yes _____ No X

**City of Valley, Nebraska
 Schedule of Findings and Questioned Costs (Continued)
 Year Ended September 30, 2024**

A. SUMMARY OF AUDIT RESULTS (Continued)

Programs considered to be a major program of the City include:

	Federal Assistance Listing Number
Safe Drinking Water State Revolving Funds	66.468
Threshold used for distinguishing between Type A and B programs:	\$750,000
Is the City considered to be a low-risk auditee?:	Yes _____ No <u> X </u>

B. FINDINGS – FINANCIAL STATEMENT AUDIT

No findings that apply to the financial statement audit were noted.

C. FINDINGS – MAJOR FEDERAL AWARD PROGRAM AUDIT

No findings that apply to the major federal award program audit were noted.

**City of Valley, Nebraska
Schedule of Prior Year Audit Findings
Year Ended September 30, 2024**

FINANCIAL STATEMENT AUDIT

MATERIAL WEAKNESS OR SIGNIFICANT DEFICIENCY NOTED	CURRENT STATUS
No prior year findings.	N/A.

FEDERAL AWARD PROGRAM AUDIT

MATERIAL WEAKNESS OR SIGNIFICANT DEFICIENCY NOTED	CURRENT STATUS
2023-001 The City was unable to provide supporting documentation for one of the three contractors tested to ensure the proper procurement standards were followed in accordance with Uniform Guidance.	Finding has been closed.

DRAFT

RESOLUTION NO. 2025-13

BE IT RESOLVED BY THE MAYOR AND CITY COUNCIL OF THE CITY OF VALLEY, DOUGLAS COUNTY, NEBRASKA:

The Application for Payment No. 4 filed with the Clerk by the special engineer of the project, showing the amount of material furnished and work performed in the City under contract heretofore from **Eriksen Construction for Water Treatment Plant Expansion** and the statements of the engineer and others set out below are hereby approved and the Council finds that the materials therein set out have been furnished and have been received by the City and work has been performed and claim therefor is hereby submitted as follows:

1. ORIGINAL CONTRACT PRICE	<u>\$8,900,670.00</u>
2. Net change by Change Orders	
3. Current Contract Price (Line 1 + 2)	<u>\$8,900,670.00</u>
4. TOTAL COMPLETED AND STORED TO DATE (Sum of Column G Lump Sum Total & Column J Unit Price Total)	<u>\$631,252.50</u>
5. RETAINAGE:	
a. 10% x \$631,252.50 Work Completed	<u>\$63,125.25</u>
b. 10% x \$_____ Stored Material	\$0.00
c. Total Retainage (Line 5.a + Line 5.b)	<u>\$63,125.25</u>
6. AMOUNT ELIGIBLE TO DATE (Line 4 + Line 5.c)	<u>\$568,127.25</u>
7. LESS PREVIOUS PAYMENTS (Line 6 from prior Application)	<u>\$495,603.00</u>
8. AMOUNT DUE THIS APPLICATION	<u>\$72,524.25</u>
9. BALANCE TO FINISH, PLUS RETAINAGE (Line 3 – Line 4)	<u>\$8,269,417.50</u>

PAYMENT OF: **\$72,524.25**

NOW, THEREFORE, BE IT RESOLVED THAT the Valley City Council consents to and authorizes payment to:

ERIKSEN CONSTRUCTION \$72,524.25

PASSED AND APPROVED THIS 13th DAY OF MAY 2025.

CITY OF VALLEY, DOUGLAS COUNTY, NEBRASKA

Cindy Grove, Mayor

ATTEST:

Christie Donnermeyer, City Clerk

Contractor's Application for Payment

Owner: <u>City of Valley, Nebraska</u>	Owner's Project No.: _____
Engineer: <u>Eagle Engineering Group</u>	Engineer's Project No.: <u>23-66</u>
Contractor: <u>Eriksen Construction</u>	Contractor's Project No.: <u>979</u>
Project: <u>Water Treatment Plant Expansion</u>	
Contract: <u>Water Treatment Plant Expansion</u>	

Application No.: <u>4</u>	Application Date: <u>5/1/2025</u>
Application Period: From <u>4/1/2025</u>	to <u>4/30/2025</u>

1. Original Contract Price	\$ 8,900,670.00
2. Net change by Change Orders	\$ -
3. Current Contract Price (Line 1 + Line 2)	\$ 8,900,670.00
4. Total Work completed and materials stored to date (Sum of Column G Lump Sum Total and Column J Unit Price Total)	\$ 631,252.50
5. Retainage	
a. <u>10%</u> X \$ 631,252.50 Work Completed	\$ 63,125.25
b. <u>10%</u> X \$ - Stored Materials	\$ -
c. Total Retainage (Line 5.a + Line 5.b)	\$ 63,125.25
6. Amount eligible to date (Line 4 - Line 5.c)	\$ 568,127.25
7. Less previous payments (Line 6 from prior application)	\$ 495,603.00
8. Amount due this application	\$ 72,524.25
9. Balance to finish, including retainage (Line 3 - Line 4)	\$ 8,269,417.50

Contractor's Certification

The undersigned Contractor certifies, to the best of its knowledge, the following:

- (1) All previous progress payments received from Owner on account of Work done under the Contract have been applied on account to discharge Contractor's legitimate obligations incurred in connection with the Work covered by prior Applications for Payment;
- (2) Title to all Work, materials and equipment incorporated in said Work, or otherwise listed in or covered by this Application for Payment, will pass to Owner at time of payment free and clear of all liens, security interests, and encumbrances (except such as are covered by a bond acceptable to Owner indemnifying Owner against any such liens, security interest, or encumbrances); and
- (3) All the Work covered by this Application for Payment is in accordance with the Contract Documents and is not defective.

Contractor: Eriksen Construction

Signature: Al Schoemaker **Date:** 5/1/2025

Recommended by Engineer	Approved by Owner
By: _____	By: _____
Title: _____	Title: _____
Date: _____	Date: _____
Approved by Funding Agency	
By: _____	By: _____
Title: _____	Title: _____
Date: _____	Date: _____

Progress Estimate - Unit Price Work

Contractor's Application for Payment

Owner: City of Valley, Nebraska
 Engineer: Eagle Engineering Group
 Contractor: Eriksen Construction
 Project: Water Treatment Plant Expansion
 Contract: Water Treatment Plant Expansion
 Owner's Project No.: 23-66
 Contractor's Project No.: 979

Application No.: 4		Application Period: From 04/01/25 to 04/30/25		Application Date: 05/01/25																	
A	B	C		D		E		F		G		H		I		J		K		L	
		Contract Information		Contract Information		Contract Information		Contract Information		Contract Information		Contract Information		Contract Information		Contract Information		Contract Information		Contract Information	
Bid Item No.	Description	Item Quantity	Units	Unit Price (\$)	Value of Bid Item (C X E) (\$)	Estimated Quantity Incorporated in the Work	Value of Work Completed to Date (E X G) (\$)	Materials Currently Stored (m) (H) (\$)	Work completed and Materials Stored to Date (H + I) (\$)	% of Value of Item (I / J) (%)	Balance to Finish (J - I) (\$)										
Original Contract																					
1																					
2																					
3																					
4																					
5																					
6																					
7																					
8																					
9																					
10																					
11																					
12																					
13																					
14																					
15																					
16																					
17																					
18																					
19																					
20																					
Original Contract Totals										\$	\$	\$	\$	\$	\$	\$	\$	\$	\$	\$	\$

Progress Estimate - Lump Sum Work

Owner: City of Valley, Nebraska
Engineer: Eagle Engineering Group
Contractor: Eriksen Construction
Project: Water Treatment Plant Expansion
Contract: Water Treatment Plant Expansion

Contractor's Application for Payment

Owner's Project No.:
Engineer's Project No.: 23-66
Contractor's Project No.: 979

Item No.	Description	C Scheduled Value (\$)	Application Period: From 04/01/25 to 04/30/25		F Materials Currently Stored (not in D or E) (\$)	G Work Completed and Materials Stored to Date (D + E + F) (\$)	H % of Scheduled Value (G / C) (%)	I Balance to Finish (C - G) (\$)
			D (D + E) From Previous Application (\$)	E Work Completed This Period (\$)				
Original Contract								
1	Mobilization	345,670.00	259,252.50			259,252.50	75%	86,417.50
2	Demolition	12,500.00					0%	12,500.00
3	Concrete	1,100,000.00		50,000.00		50,000.00	5%	1,050,000.00
4	Structural Precast	90,000.00					0%	90,000.00
5	Masonry	330,000.00					0%	330,000.00
6	Wall Panels	220,000.00					0%	220,000.00
7	Roofing	120,000.00					0%	120,000.00
8	Doors/Windows	130,000.00					0%	130,000.00
9	Framed Walls	58,000.00					0%	58,000.00
10	Ceilings	25,000.00					0%	25,000.00
11	Painting/Coatings	150,000.00					0%	150,000.00
12	Plumbing	145,000.00					0%	145,000.00
13	HVAC	55,000.00					0%	55,000.00
14	Electrical/Controls	1,400,000.00					0%	1,400,000.00
15	Earthwork	160,000.00		150,000.00		150,000.00	94%	10,000.00
16	Dewatering	350,000.00	152,000.00	20,000.00		172,000.00	49%	178,000.00
17	Paving	25,000.00					0%	25,000.00
18	Fence	240,000.00					0%	240,000.00
19	Water Distribution	165,000.00					0%	165,000.00
20	Sanitary Sewer	190,000.00					0%	190,000.00
21	Storm Sewer	55,000.00					0%	55,000.00
22	Process	700,000.00					0%	700,000.00
23	Pumps	450,000.00					0%	450,000.00
24	Aeriation/Filters	2,300,000.00					0%	2,300,000.00
25	Chemical Feed Equipment	80,000.00					0%	80,000.00
26	Seeding	4,500.00					0%	4,500.00
27								
28								
29								
		Original Contract Totals	\$ 8,900,670.00	\$ 411,252.50	\$ 220,000.00	\$ 631,252.50	7%	\$ 8,269,417.50

RESOLUTION NO. 2025-14

BE IT RESOLVED BY THE MAYOR AND CITY COUNCIL OF THE CITY OF VALLEY, DOUGLAS COUNTY, NEBRASKA:

The Application for Payment No. 3 filed with the Clerk by the special engineer of the project, showing the amount of material furnished and work performed in the City under contract heretofore from **Vrba Construction, Inc.** for **Valhaven (SW No. 2) and Ginger Woods No. 2 Lift Station Improvements** and the statements of the engineer and others set out below are hereby approved and the Council finds that the materials therein set out have been furnished and have been received by the City and work has been performed and claim therefor is hereby submitted as follows:

1. ORIGINAL CONTRACT PRICE	<u>\$348,020.00</u>
2. Net change by Change Orders	<u>\$(56,219.00)</u>
3. Current Contract Price (Line 1 + 2)	<u>\$291,801.00</u>
4. TOTAL COMPLETED AND STORED TO DATE (Sum of Column G Lump Sum Total & Column J Unit Price Total)	<u>\$198,006.00</u>
5. RETAINAGE:	
a. 10% x \$ 88,795.00 Work Completed	<u>\$8,879.50</u>
b. 10% x \$109,211.00 Stored Material	<u>\$10,921.10</u>
c. Total Retainage (Line 5.a + Line 5.b)	<u>\$19,800.60</u>
6. AMOUNT ELIGIBLE TO DATE (Line 4 + Line 5.c)	<u>\$178,205.40</u>
7. LESS PREVIOUS PAYMENTS (Line 6 from prior Application)	<u>\$98,289.90</u>
8. AMOUNT DUE THIS APPLICATION	<u>\$79,915.50</u>
9. BALANCE TO FINISH, PLUS RETAINAGE (Line 3 – Line 4)	<u>\$93,795.00</u>

PAYMENT OF: \$79,915.50

NOW, THEREFORE, BE IT RESOLVED THAT the Valley City Council consents to and authorizes payment to:

VRBA CONSTRUCTION, INC. \$79,915.50

PASSED AND APPROVED THIS 13th DAY OF MAY 2025.

CITY OF VALLEY, DOUGLAS COUNTY, NEBRASKA

Cindy Grove, Mayor

ATTEST:

Christie Donnermeyer, City Clerk

Contractor's Application for Payment

Owner: <u>City of Valley, Nebraska</u>	Owner's Project No.: <u>n/a</u>
Engineer: <u>EAGLE ENGINEERING GROUP</u>	Engineer's Project No.: <u>22-93</u>
Contractor: <u>Vrba Construction Inc.</u>	Contractor's Project No.: <u>n/a</u>
Project: <u>Valhaven (SW No. 2) And Ginger Woods No. 2 Lift Station Improvements</u>	
Contract: <u>Valhaven (SW No. 2) And Ginger Woods No. 2 Lift Station Improvements</u>	
Application No.: <u>3</u>	Application Date: <u>5/2/2025</u>
Application Period: From <u>6/15/2024</u> to <u>4/30/2025</u>	

1. Original Contract Price	\$	348,020.00
2. Net change by Change Orders	\$	(56,219.00)
3. Current Contract Price (Line 1 + Line 2)	\$	291,801.00
4. Total Work completed and materials stored to date (Sum of Column G Lump Sum Total and Column J Unit Price Total)	\$	198,006.00
5. Retainage		
a. <u>10%</u> X <u>\$ 88,795.00</u> Work Completed	\$	8,879.50
b. <u>10%</u> X <u>\$ 109,211.00</u> Stored Materials	\$	10,921.10
c. Total Retainage (Line 5.a + Line 5.b)	\$	19,800.60
6. Amount eligible to date (Line 4 - Line 5.c)	\$	178,205.40
7. Less previous payments (Line 6 from prior application)	\$	98,289.90
8. Amount due this application	\$	79,915.50
9. Balance to finish, including retainage (Line 3 - Line 4)	\$	93,795.00

Contractor's Certification

The undersigned Contractor certifies, to the best of its knowledge, the following:

(1) All previous progress payments received from Owner on account of Work done under the Contract have been applied on account to discharge Contractor's legitimate obligations incurred in connection with the Work covered by prior Applications for Payment;

(2) Title to all Work, materials and equipment incorporated in said Work, or otherwise listed in or covered by this Application for Payment, will pass to Owner at time of payment free and clear of all liens, security interests, and encumbrances (except such as are covered by a bond acceptable to Owner indemnifying Owner against any such liens, security interest, or encumbrances); and

(3) All the Work covered by this Application for Payment is in accordance with the Contract Documents and is not defective.

Contractor: Vrba Construction Inc.

Signature: _____ **Date:** 5/2/2025

Recommended by Engineer	Approved by Owner
By: _____	By: _____
Title: <u>Project Manager</u>	Title: <u>Mayor</u>
Date: _____	Date: _____
Approved by Funding Agency	
By: _____	By: _____
Title: _____	Title: _____
Date: _____	Date: _____

Progress Estimate - Lump Sum Work

Contractor's Application for Payment

Owner:	City of Valley, Nebraska	Owner's Project No.:	n/a
Engineer:	EAGLE ENGINEERING GROUP	Engineer's Project No.:	22-93
Contractor:	Vrba Construction Inc.	Contractor's Project No.:	n/a
Project:	Valhaven (SW No. 2) And Ginger Woods No. 2 Lift Station Improvements		
Contract:	Valhaven (SW No. 2) And Ginger Woods No. 2 Lift Station Improvements		

Application No.: 3 **Application Period:** From 06/15/24 to 04/30/25 **Application Date:** 05/02/25

A	B	C	D		E	F	G	H	I
Item No.	Description	Scheduled Value (\$)	Work Completed		Materials Currently Stored (not in D or E) (\$)	Work Completed and Materials Stored to Date (D + E + F) (\$)	% of Scheduled Value (G / C) (%)	Balance to Finish (C - G) (\$)	
			(D + E) From Previous Application (\$)	This Period (\$)					
Change Orders									
CO-01	Value Engineering (Revise lift station encl to valve pit)	(73,020.00)				-	0%	(73,020.00)	
CO-02	Electrical Equipment - Ginger Woods and Valhaven	16,801.00			16,801.00	16,801.00	100%	-	
						-		-	
						-		-	
						-		-	
						-		-	
						-		-	
						-		-	
						-		-	
						-		-	
						-		-	
						-		-	
						-		-	
						-		-	
						-		-	
						-		-	
						-		-	
						-		-	
						-		-	
						-		-	
Change Order Totals		\$ (56,219.00)	\$ -	\$ -	\$ 16,801.00	\$ 16,801.00	-30%	\$ (73,020.00)	
Original Contract and Change Orders									
Project Totals		\$ 291,801.00	\$ -	\$ 88,795.00	\$ 109,211.00	\$ 198,006.00	68%	\$ 93,795.00	

RESOLUTION NO. 2025-15

BE IT RESOLVED BY THE MAYOR AND CITY COUNCIL OF THE CITY OF VALLEY, DOUGLAS COUNTY, NEBRASKA:

The Application for Payment No. 1 filed with the Clerk by the special engineer of the project, showing the amount of material furnished and work performed in the City under contract heretofore from **JEM Restoration Services, Inc.** for **Ginger Cove Bridge Steel Girder Blasting & Repainting** and the statements of the engineer and others set out below are hereby approved and the Council finds that the materials therein set out have been furnished and have been received by the City and work has been performed and claim therefor is hereby submitted as follows:

1. ORIGINAL CONTRACT PRICE	<u>\$101,242.00</u>
2. Net change by Change Orders	<u>\$0.00</u>
3. Current Contract Price (Line 1 + 2)	<u>\$101,242.00</u>
4. TOTAL COMPLETED AND STORED TO DATE (Sum of Column G Lump Sum Total & Column J Unit Price Total)	<u>\$101,242.00</u>
5. RETAINAGE:	
a. 0% x \$101,242.00 Work Completed	<u>\$0.00</u>
b. 0% x \$ _____ Stored Material	<u>\$0.00</u>
c. Total Retainage (Line 5.a + Line 5.b)	<u>\$0.00</u>
6. AMOUNT ELIGIBLE TO DATE (Line 4 + Line 5.c)	<u>\$101,242.00</u>
7. LESS PREVIOUS PAYMENTS (Line 6 from prior Application)	<u>\$0.00</u>
8. AMOUNT DUE THIS APPLICATION	<u>\$101,242.00</u>
9. BALANCE TO FINISH, PLUS RETAINAGE (Line 3 – Line 4)	<u>\$0.00</u>

PAYMENT OF: **\$101,242.00**

NOW, THEREFORE, BE IT RESOLVED THAT the Valley City Council consents to and authorizes payment to:

JEM RESTORATION SERVICES, INC. \$101,242.00

PASSED AND APPROVED THIS 13th DAY OF MAY 2025.

CITY OF VALLEY, DOUGLAS COUNTY, NEBRASKA

Cindy Grove, Mayor

ATTEST:

Christie Donnermeyer, City Clerk

Contractor's Application for Payment

Owner: <u>City of Valley, Nebraska</u>	Owner's Project No.: _____
Engineer: <u>EAGLE ENGINEERING GROUP</u>	Engineer's Project No.: <u>24-61</u>
Contractor: <u>JEM Restoration Services Inc.</u>	Contractor's Project No.: _____
Project: <u>Ginger Cove Bridge Steel Girder Blasting & Repainting</u>	
Contract: <u>Ginger Cove Bridge Steel Girder Blasting & Repainting, Valley, NE</u>	
Application No.: <u>1</u>	Application Date: <u>5/7/2025</u>
Application Period: From <u>4/1/2025</u> to <u>5/7/2025</u>	

1. Original Contract Price	\$	101,242.00
2. Net change by Change Orders	\$	-
3. Current Contract Price (Line 1 + Line 2)	\$	101,242.00
4. Total Work completed and materials stored to date (Sum of Column G Lump Sum Total and Column J Unit Price Total)	\$	101,242.00
5. Retainage		
a. <u>0%</u> X <u>\$ 101,242.00</u> Work Completed	\$	-
b. <u>0%</u> X <u>\$ -</u> Stored Materials	\$	-
c. Total Retainage (Line 5.a + Line 5.b)	\$	-
6. Amount eligible to date (Line 4 - Line 5.c)	\$	101,242.00
7. Less previous payments (Line 6 from prior application)	\$	-
8. Amount due this application	\$	101,242.00
9. Balance to finish, including retainage (Line 3 - Line 4)	\$	-

Contractor's Certification

The undersigned Contractor certifies, to the best of its knowledge, the following:

(1) All previous progress payments received from Owner on account of Work done under the Contract have been applied on account to discharge Contractor's legitimate obligations incurred in connection with the Work covered by prior Applications for Payment;

(2) Title to all Work, materials and equipment incorporated in said Work, or otherwise listed in or covered by this Application for Payment, will pass to Owner at time of payment free and clear of all liens, security interests, and encumbrances (except such as are covered by a bond acceptable to Owner indemnifying Owner against any such liens, security interest, or encumbrances); and

(3) All the Work covered by this Application for Payment is in accordance with the Contract Documents and is not defective.

Contractor: JEM Restoration Services Inc.

Signature: _____ **Date:** 5/7/2025

Recommended by Engineer	Approved by Owner
By: _____	By: _____
Title: <u>Project Manager</u>	Title: <u>Mayor</u>
Date: <u>5/7/2025</u>	Date: <u>5/13/2025</u>
Approved by Funding Agency	
By: _____	By: _____
Title: _____	Title: _____
Date: _____	Date: _____

Progress Estimate - Lump Sum Work

Contractor's Application for Payment

Owner:	City of Valley, Nebraska	Owner's Project No.:	
Engineer:	EAGLE ENGINEERING GROUP	Engineer's Project No.:	24-61
Contractor:	JEM Restoration Services Inc.	Contractor's Project No.:	
Project:	Ginger Cove Bridge Steel Girder Blasting & Repainting		
Contract:	Ginger Cove Bridge Steel Girder Blasting & Repainting, Valley, NE		

Application No.: 1 **Application Period:** From 04/01/25 to 05/07/25 **Application Date:** 05/07/25

A	B	C	D	E	F	G	H	I
Item No.	Description	Scheduled Value (\$)	Work Completed		Materials Currently Stored (not in D or E) (\$)	Work Completed and Materials Stored to Date (D + E + F) (\$)	% of Scheduled Value (G / C) (%)	Balance to Finish (C - G) (\$)
			(D + E) From Previous Application (\$)	This Period (\$)				
Original Contract								
	Blasting & Repainting	101,242.00	-	101,242.00		101,242.00	100%	-
						-		-
						-		-
						-		-
						-		-
						-		-
						-		-
						-		-
						-		-
						-		-
						-		-
						-		-
						-		-
						-		-
						-		-
						-		-
						-		-
						-		-
						-		-
Original Contract Totals		\$ 101,242.00	\$ -	\$ 101,242.00	\$ -	\$ 101,242.00	100%	\$ -

**BID TABULATION**

Project Park Avenue and Platte Street Paving Improvements		Project No. 24-69
Owner City of Valley		Bid Date: May 8, 2025
Address 203 North Spruce Street Valley, NE 68064		Time: 10:15 AM
BIDDER	BID AMOUNT	COMMENT
2THET CONSTRUCTION	\$289,757.40	
YONG CONSTRUCTION	\$344,025.60	
VALLEY CORP.	\$356,580.41	
METRO CONCRETE REPLACEMENT LLC	\$361,991.30	
HD UTILITIES AND GRADING, LLC	\$366,030.15	
BLUFFS PAVING & UTILITY, INC.	\$378,287.42	
CONSTRUCTORS INC.	\$420,587.66	
BAUER INFRASTRUCTURE	\$441,981.04	
GRAHAM CONSTRUCTION INC.	\$442,770.00	
CHARLES VRANA AND SON CONSTRUCTION COMPANY	\$555,489.00	
STEVE HARRIS CONSTRUCTION, INC.	No Bid	
BIDDING NOTES		
Engineer's Opinion of Probable Construction Costs: \$400,000		

Change Order No. 1

Owner:	City of Valley, Nebraska	Owner's Project No.:	n/a
Engineer:	EAGLE ENGINEERING GROUP	Engineer's Project No.:	24-69
Contractor:	2 The T Construction LLC	Contractor's Project No.:	n/a
Project:	Park Avenue and Platte Street Paving Improvements		
Contract Name:	Park Avenue and Platte Street Paving Improvements, Valley, NE		
Date Issued:	May 9, 2025	Effective Date of Change order:	May 13, 2025

The Contract is modified as follows upon execution of this Change Order:

Description:

Add six remove and replace street pavement locations from other utility work and additional panels within the City Limits and includes early mobilization

Attachments: *[List documents supporting change]*
Attachment No. 1 To Change Order No. 1

Change in Contract Times
[State Contract Times as either a specific date or a number of days]

Change in Contract Price

<p>Original Contract Price:</p> <p style="text-align: right;">\$ <u> \$289,757.40</u></p>	<p>Original Contract Times:</p> <p style="text-align: right;">Substantial Completion: <u> September 1, 2025</u></p> <p style="text-align: right;">Ready for Final Payment: <u> September 15, 2025</u></p>
<p>Increase (Decrease) from previously approved Change Orders No. - to No. - :</p> <p style="text-align: right;">\$ <u> \$0.00</u></p>	<p>Increase (Decrease) from previously approved Change Orders No. - to No. - :</p> <p style="text-align: right;">Substantial Completion: <u> 0</u></p> <p style="text-align: right;">Ready for Final Payment: <u> 0</u></p>
<p>Contract Price prior to this Change Order:</p> <p style="text-align: right;">\$ <u> \$289,757.40</u></p>	<p>Contract Times prior to this Change Order:</p> <p style="text-align: right;">Substantial Completion: <u> September 1, 2025</u></p> <p style="text-align: right;">Ready for Final Payment: <u> September 15, 2025</u></p>
<p>Increase (Decrease) of this Change Order:</p> <p style="text-align: right;">\$ <u> \$33,600.00</u></p>	<p>Increase (Decrease) this Change Order:</p> <p style="text-align: right;">Substantial Completion: <u> 0</u></p> <p style="text-align: right;">Ready for Final Payment: <u> 0</u></p>
<p>Contract Price incorporating this Change Order:</p> <p style="text-align: right;">\$ <u> \$323,357.40</u></p>	<p>Contract Times with all approved Change Orders:</p> <p style="text-align: right;">Substantial Completion: <u> September 1, 2025</u></p> <p style="text-align: right;">Ready for Final Payment: <u> September 15, 2025</u></p>

Recommended by Engineer (if required)

Accepted By Contractor

By: _____
Title: Project Manager
Date: _____

By: _____
Title: Mayor
Date: _____

Authorized by Owner

Approved by Funding Agency (if applicable)

By: _____
Title: Mayor
Date: _____

By: _____
Title: _____
Date: _____

Attachment No. 1 to Change Order No.: 1

Project: **Park Avenue and Platte Street Paving Improvements**

Dated: **May 9, 2025**

Project No. **24-69**

ITEM NO.	DESCRIPTION OF WORK	UNIT PRICE	UNITS	CONTRACT QUANTITY	ACTUAL CONSTRUCTED QUANTITY	QUANTITY CHANGE	CHANGE IN CONTRACT PRICE
28	REMOVE & REPLACE 9-INCH CONCRETE PAVEMENT (TYPE OPW4000)	\$105.00	SY	0	320.0	320.0	\$33,600.00
TOTAL							\$33,600.00

NEBRASKA

Good Life. Great Service.

**COMMISSION ON LAW ENFORCEMENT
AND CRIMINAL JUSTICE**

April 14, 2025

Chief Bobby Martinez
Valley Police Department

RE: AUDIT OF 2024 Continuing Education Hours

Dear Chief Martinez;

On March 12, 2025 your agency was selected to participate in the state wide audit of 2024 Continuing Education hours.

On April 8, 2025 the Training Center received your documentation of the 2024 hours for the following individuals:

Shawna West
Caleb Clark
Geoffrey Willmann

The documents provided demonstrated that your officers were compliant in meeting the mandated Continuing Education requirements for 2024.

Thank you for your time and assistance.

Sincerely,



Jessie Wagoner, Program Manager
Copy: PSAC

Mark Stephenson, Director
Law Enforcement Training Center

3600 North Academy Road
Grand Island, Nebraska 68801

ncc.nebraska.gov

OFFICE 308-385-6030
FAX 308-385 6032





**Arbor Day
Foundation.**

211 N. 12th St.
Lincoln, NE 68508
arborday.org

Mayor Cindy Grove
PO Box 682
Valley, NE 68064

Dear Mayor Cindy Grove,

On behalf of the Arbor Day Foundation, I'm happy to extend my warmest congratulations to Valley on successfully achieving 2024 Tree City USA status. This well-deserved recognition is a testament to your community's unwavering commitment to the planting, care, and celebration of trees.

In an era where cities and towns are facing increasing challenges related to air quality, public health, and climate resilience, nurturing urban forests has never been more important. By prioritizing tree stewardship, you've not only helped enhance Valley's beauty and livability, but you've also invested in a healthier, more sustainable future for your residents.

The Arbor Day Foundation's Tree City USA program has a long legacy of supporting a nationwide network of passionate organizers and tireless tree planters. Since 1976, we've connected with more than 3,500 communities of all sizes to create and maintain green spaces. While we may all work in different corners of the country, we are all working in unison to create positive change through trees.

To be named a Tree City USA is to be part of something bigger.

Whether Valley is newer to the Tree City USA recognition program, or you've been part of our network for decades, we hope you are as excited as we are to share this accomplishment with your local media and your residents. To that end, we've included a press release for you to distribute at your convenience. A digital copy of the press release and other materials can be found in the Tree City USA Resource Center online at arborday.org/TreeCitytoolkit.

Once again, congratulations on this outstanding achievement and thank you for your dedication to Valley's tree canopy. We believe cities that take care of their trees, take care of their people.

Best Regards,

Dan Lambe
Chief Executive of the Arbor Day Foundation

THE EFFECTS OF SOCIAL MEDIA ON YOUTH MENTAL HEALTH:

RISK FACTORS AND PROTECTIVE MEASURES



**OPEN TO THE PUBLIC
TUESDAY, MAY 20TH, 2025
7:00 PM - 8:00 PM**

DC West High School Performing Arts Center

401 S. Pine Street
Valley, NE 68064

Presented by:

The Kim Foundation and the Federal Bureau of Investigation (FBI)

No RSVP Required
Contact Information:
Officer Kenneth Dohrmann
Valley Police Department
kdohrmann@valleyne.org

