

**Agenda**  
**Midlothian ISD**  
**Board of Trustees Regular Meeting**

L.A. Mills Administration Building  
100 Walter Stephenson Road  
Midlothian, Texas 76065

**April 19, 2021 – 5:00 PM**

---

A Regular Meeting of the Board of Trustees of Midlothian ISD will be held April 19, 2021, beginning at 5:00 PM.

The subjects to be discussed or considered, or upon which any formal action may be taken are listed on the agenda, which is attached to, and made a part of this Notice. Items do not have to be taken in the order shown on this meeting notice.

For those attending in person, social distancing guidelines will be followed. Members of the public may access this meeting in real time by clicking the [video conference link](#) and selecting the Board of Trustees Regular Meeting for April 19, 2021.

The open portions of this meeting will be streamed live and recorded. The video will be made available to the public on the District's website.

**PUBLIC COMMENT** – Public comments related to this meeting will be accepted in person and virtually, in accordance with the Open Meetings Act and Local District Policy, BED(LOCAL). Members of the public wishing to address the Board during the public comment portion of this regular meeting shall be limited to five minutes.

Individuals wishing to speak remotely, should complete an online [Public Comment Form](#) for virtual participation prior to 4:00 pm on April 19, 2021. **Please note:** *Comments will not be read into the record. Those participating virtually will be admitted to the meeting at the designated time to speak via the Zoom [link](#) with meeting ID: 821 0648 9872.* In-person participants must sign in and complete a "Public Comment Participation Form" and present it to the Board President or designee by 5:50 p.m. on April 19, 2021. If a completed form for public comment is not received by the applicable deadline posted, the individual will not be able to participate in public comment at this meeting.

In accordance with the Texas Open Meetings Act, Board Members will listen to the comments. The Board, through the presiding officer or Superintendent, can offer factual information, cite Board policy, or direct the administration to investigate items and report back to the Board, but shall not engage in a two-way dialogue with patrons.

**1. FIRST ORDER OF BUSINESS**

A. Announcement by the presiding officer that a quorum of Board members is present, that the meeting has been duly called, and that notice of the meeting has been posted in accordance with the Texas Open Meetings Act, Texas Government Code Chapter 551

**2. CLOSED SESSION as authorized by the Texas Open Meetings Act, Texas Government Code Chapter 551.**

A. Consideration of Personnel, Texas Government Codes 551.074 - Resignations,

Terminations, and Non-renewals of Professional Employees, Employment, Leaves of Absences, Personnel Issues

1. Consider Selection of Elementary #8 Principal	
2. Consider Selection of Irvin Elementary Principal	
B. Consider Purchase, Exchange, Lease, or Value of Real Property 551.072	
C. Students, Texas Government Code 551.082, 551.0821	
1. Discipline Issues	
2. Non-Discipline Issues	
D. Consider Safety and Security Update, Texas Government Code 551.	
3. RECONVENE TO OPEN SESSION	
4. INTRODUCTION OF MEETING	
A. Invocation	
B. Pledges of Allegiance - LaRue Miller Elementary	
5. PRESENTATIONS / RECOGNITIONS	
A. Military Appointment Recognitions	5
B. National Merit Finalist Recognition	6
C. MEF Grant Recipients	7
D. MHS State Powerlifting Recognition	9
E. Heritage Girls Soccer Recognition	10
F. Recognition of Donations	12
6. PUBLIC COMMENT - Members of the public may address the Board during the public comment portion of the board meeting in accordance with Board policy BED (LOCAL). Individuals wishing to speak shall follow the procedures outlined above	
7. CONSENT AGENDA	
A. Consider Meeting Minutes	
1. February 8, 2021 - Special Meeting Minutes	13
2. March 22, 2021 - Regular Meeting Minutes	15
3. March 29, 2021 - Special Meeting Minutes	20
4. April 5, 2021 - Special Meeting Minutes	22
5. April 6, 2021 - Special Meeting Minutes	24
6. April 7, 2021 - Special Meeting Minutes	26
7. April 8, 2021 - Special Meeting Minutes	28
8. April 9, 2021 - Special Meeting Minutes	30
B. Quarterly Investment Report	31
C. Consider Requisitions over \$50,000	33
D. Consider Budget Amendments	54
E. Consider Approval of Gifts and/or Donations	56
F. Consider Teacher Contracts 2021-2022	57
G. Consider IMA TEKS Certification Form for 2021-2022	58
H. Consider Summer Work Hours	60
I. Consider Student Dress Code	61
J. Consider Waivers for Asynchronous Testing Dates	62
K. CSP2021-012 Approval of Multi Campus Roofing Projects	63

L. CSP2021-013 Approval of Elementary #8 General Contractor	69
M. RFP2021-018 Approval of Heritage Phase #2 Furniture	77
N. Consider Purchase of FF&E Technology Items for Heritage Phase #2	152
<b>8. INFORMATION ITEMS</b>	
A. M*Powered Data Review and Preliminary Pilot Review for Device Refresh	153
B. Consider Update on JROTC Program	165
C. Consider PreK Adoptions for 2021/2022	174
D. Consider Virtual Learning Design Team Update for 2021-2022	180
<b>9. DISCUSSION/ACTION ITEMS</b>	
A. Consider Selection of Principal(s) for Elementary #8 and Irvin Elementary	214
B. Consider 4Q Demographer Report	215
C. Consider Zoning Decision	262
D. Consider CW (LOCAL) Naming of Elementary #8	292
E. Consider COVID Update & Possible Amendments to Protocols: Health & Safety Mitigation Year in Review, Mask Mandate, Quarantine Time Period, Event Capacity, and Vaccine Updates	294
F. Consider Board Resolution to State Officials Regarding Federal Elementary and Secondary School Emergency Relief Funds	310
G. Consider Board of Trustee Continuing Education Hours	313
H. Consider Agenda Items/Topics for Upcoming Meetings	
I. Action, if any, on Items Discussed in Closed Session	
J. Superintendent's Report and Announcements	
1. Business Reports	315
<b>10. ADJOURNMENT OF MEETING</b>	

If, during the course of the meeting covered by this Notice, the Board of Trustees should determine that a closed meeting or session of the Board of Trustees is required, then such closed meeting or session as authorized by the Texas Open Meetings Act, Texas Government Code Section 551.001 et seq., will be held by the School Board at the date, hour, and place given in this Notice or as soon after the commencement of the meeting covered by this Notice as the School Board may conveniently meet in such closed meeting or session concerning any and all purposes permitted by the Act, including, but not limited to the following sections and purposes:

Texas Government Code Section:

- 551.071 Private consultation with the board's attorney.
- 551.072 Discussing purchase, exchange, lease, or value of real property.
- 551.073 Discussing negotiated contracts for prospective gifts or donations.
- 551.074 Discussing personnel or to hear complaints against personnel.
- 551.075 To confer with employees of the school district to receive information or to ask questions.
- 551.076 Considering the deployment, specific occasions for, or implementation of, security personnel, or devices.
- 551.082 Considering discipline of a public school child, or complaint or charge against personnel.
- 551.0821 Discussing personally identifiable information about a public school student.

- 551.083 Considering the standards, guidelines, terms, or conditions the board will follow, or will instruct its representatives to follow, in consultation with representatives of employees groups.
- 551.084 Excluding witnesses from a hearing.

Should any final action, final decision, or final vote be required in the opinion of the school Board with regard to any matter considered in such closed meeting or session, then the final action, final decision, or final vote shall be either:

- (a) in the open meeting covered by the Notice upon the reconvening of the public meeting; or
- (b) at a subsequent public meeting of the School Board upon notice thereof; as the School Board shall determine.

Theda McGrew  
Superintendent Administrative Assistant

**Midlothian I.S.D. School Board Agenda Item Detail**  
**L.A. Mills Administrative Complex Boardroom**

<b>Board Meeting Date:</b>	<b>April 19, 2021</b>	
<b>Item:</b>	<b>Board Recognition of MHS Military Appointments</b>	
<b>Supporting Document(s):</b>	Electronic: Yes <input checked="" type="checkbox"/> No <input type="checkbox"/>	Hard Copy: Yes <input type="checkbox"/> No <input checked="" type="checkbox"/>
<b>Background Information:</b>	<p>Midlothian High School has the following students appointed to United States Military Academies:</p> <ul style="list-style-type: none"> <li>● Landon Buford - Naval Academy</li> <li>● Max Allen - Air Force Academy</li> <li>● Kaleb Tompkins - Air Force Academy</li> <li>● Corbin Green - Air Force Academy</li> </ul> <p>This is a prestigious honor offered to candidates by congressional nomination.</p>	
<b>Fiscal Impact/Budget Function Code:</b>	N/A	
<b>Policy:</b>	N/A	
<b>District Goal:</b>	GOAL 1: Design innovative learning environments while increasing academic rigor through aligned teaching and learning.	
<b>Administration Recommended Option:</b>	N/A	
<b>Motion:</b>	Presentation only	
<b>Presenter:</b>	Shelle Blaylock	

**Midlothian I.S.D. School Board Agenda Item Detail**  
**L.A. Mills Administrative Complex Boardroom**

<b>Board Meeting Date:</b>	<b>April 19, 2021</b>	
<b>Item:</b>	<b>Board Recognition of National Merit Finalist</b>	
<b>Supporting Document(s):</b>	Electronic: Yes <input checked="" type="checkbox"/> No <input type="checkbox"/>	Hard Copy: Yes <input type="checkbox"/> No <input checked="" type="checkbox"/>
<b>Background Information:</b>	<p>Midlothian ISD has one nationally recognized student as a National Merit Finalist for the 2020-2021 school year.</p> <p>Each year, the National Merit Scholarship Program names 16,000 students nationwide as National Merit Semifinalists. To qualify, the students took the Preliminary SAT/National Merit Scholarship Qualifying Test (PSAT/NMSQT) as juniors and placed in the top 1 percent of scores out of 1.6 million U.S. high school students.</p> <p>The National Merit Scholarship Program also names 34,000 students each year as National Merit Commended Scholars. These students took the PSAT/NMSQT as juniors and placed in the top 2 percent of scores nationwide.</p> <p>According to the College Board, out of the more than 4.5 million high school juniors that took the PSAT/NMSQT, National Merit Scholarship selected only 7,500 finalists.</p> <p>We are recognizing Lauren Sims from Heritage High School as a 2021 National Merit Finalist.</p>	
<b>Fiscal Impact/Budget Function Code:</b>	N/A	
<b>Policy:</b>	N/A	
<b>District Goal:</b>	Design innovative learning environments while increasing academic rigor through aligned teaching and learning.	
<b>Administration Recommended Option:</b>	Presentation only	
<b>Motion:</b>	N/A	
<b>Presenter:</b>	Shelle Blaylock	

**Midlothian I.S.D. School Board Agenda Item Detail**  
**L.A. Mills Administrative Complex Boardroom**

<b>Board Meeting Date:</b>	<b>April 19, 2021</b>	
<b>Item:</b>	<b>Board Recognition of MEF Grant Recipients</b>	
<b>Supporting Document(s):</b>	Electronic: Yes <input checked="" type="checkbox"/> No <input type="checkbox"/>	Hard Copy: Yes <input type="checkbox"/> No <input checked="" type="checkbox"/>
<b>Background Information:</b>	<p>Midlothian Education Foundation awarded <b>seven</b> grants this spring to teachers who are finding amazing ways to bring innovation to our MISD classrooms and students.</p> <p>The following teachers received grant checks on March 11:</p> <p><b>Shanna Malone</b> received a grant for \$2,446.50 for “The Social Emotional Teaching Project,” benefiting students across the district.</p> <p><b>Derek Odelusi</b> received a grant for \$2,484.00 for “Break into Science with Breakout EDU,” benefiting students at Walnut Grove Middle School.</p> <p><b>Tiffany Peterman</b> received a grant for \$4,049.85 for “Droning Around Campus,” benefiting Longbranch Elementary students.</p> <p><b>Megan Lynch</b> and <b>Marigney Castleberry</b> received a grant for \$7175.90 for “What is Your Emergency: Emergency Medical Technician Training in Action,” benefiting students at Midlothian High School.</p> <p><b>Cheryl Varghese, Emily Lamm,</b> and <b>Becky Shuffield</b> received a grant for \$6,107.00 for “Lend A Hand,” benefiting students at Frank Seale Middle School.</p> <p><b>Lupe Mendoza</b> and <b>Kayleigh Jenkins</b> received a grant for \$5,000.00 for “Outdoor Education,” benefiting students at Frank Seale Middle School.</p> <p><b>Jenna Wilhoite</b> received a grant for \$4,028.93 for “STEM with Spheros,” benefiting students at McClatchey Elementary.</p> <p>In all, MEF had the pleasure of awarding over \$31,000 in grants. Additionally, on March 22 we awarded every classroom teacher in the district for their innovative teaching in both the classroom and virtually with a \$30 Amazon Gift Card. We have more fun ahead as we thank ALL of our staff in this district for the innovative ways they serve students daily.</p>	

<b>Fiscal Impact/Budget Function Code:</b>	N/A
<b>Policy:</b>	N/A
<b>District Goal:</b>	Transform our classroom to be truly student-centered through aligned teaching and learning
<b>Administration Recommended Option:</b>	N/A
<b>Motion:</b>	Presentation only
<b>Presenter:</b>	Sheri Brezeale

**Midlothian I.S.D. School Board Agenda Item Detail**  
**L.A. Mills Administrative Complex Boardroom**

<b>Board Meeting Date:</b>	April 19, 2021	
<b>Item:</b>	Board Recognition of the Midlothian High School State Powerlifters	
<b>Supporting Document(s):</b>	Electronic: Yes <input checked="" type="checkbox"/> No <input type="checkbox"/>	Hard Copy: Yes <input type="checkbox"/> No <input checked="" type="checkbox"/>
<b>Background Information:</b>	<p>Midlothian High School had several students compete at the Texas State Powerlifting Competition.</p> <p>Girls Powerlifting had eight students compete.</p> <ul style="list-style-type: none"> <li>• Grace Lopez – 8<sup>th</sup> place in the 105 lb. weight class</li> <li>• Bonnie Bartlett – 10<sup>th</sup> place in the 123 lb. weight class</li> <li>• Wendy Silva – competed in the 132 lb. weight class</li> <li>• Madeline Hodges – 9<sup>th</sup> place in the 148 lb. weight class</li> <li>• Madison Deleon – 6<sup>th</sup> place in the 165 lb. weight class</li> <li>• Allison Ramsey – 11<sup>th</sup> place in the 181 lb. weight class</li> <li>• Kodi Loper – 11<sup>th</sup> place in the 198 lb. weight class</li> <li>• Shy McKenzie – 6<sup>th</sup> place in the 220 lb. weight class</li> </ul> <p>Boys Powerlifting had two students compete.</p> <ul style="list-style-type: none"> <li>• Jordan McKenzie – 2<sup>nd</sup> place in the 165 lb. weight class</li> <li>• Kaleb Thompkins – 8<sup>th</sup> place in the 275 lb. weight class</li> </ul>	
<b>Fiscal Impact/Budget Function Code:</b>	N/A	
<b>Policy:</b>	N/A	
<b>District Goal:</b>	Transform our classroom to be truly student-centered through aligned teaching and learning	
<b>Administration Recommended Option:</b>	N/A	
<b>Motion:</b>	Presentation only	
<b>Presenter:</b>	Todd York	

**Midlothian I.S.D. School Board Agenda Item Detail**  
**L.A. Mills Administrative Complex Boardroom**

<b>Board Meeting Date:</b>	<b>April 19, 2021</b>	
<b>Item:</b>	<b>Board Recognition of HHS Jaguars Girls Soccer Team</b>	
<b>Supporting Document(s):</b>	Electronic: Yes <input checked="" type="checkbox"/> No <input type="checkbox"/>	Hard Copy: Yes <input type="checkbox"/> No <input checked="" type="checkbox"/>
<b>Background Information:</b>	<p>Congratulations to our State Finalist, Heritage High School Jaguars Girls Soccer team! The Jags return to Georgetown on Friday, April 16 to play in the State Championship Soccer game at 10 a.m. against Calallen High School. This is the second year for the Jags Girls Soccer team to play in the state championship. Congratulations to Coach Gerald Slovacek and the Jags Soccer team members:</p> <p>Jaedyn Barela  Tanner Sorenson  Riley Click  Ella Brown  Julianna Burrows  Paisley Mabra  Lori Hinson  Bailey Lamb  Hannah Dorsey  Sydney Dickson  Logan Berumen  Brynn Pollock  Emma Garvin  Kylar Kenter  Jaidyn Sandefer  Payton Grimes  Rachel Allen  Lauren Schmidt  Kerry Scott  Savana Conde  Joely Godfrey  Rose Giambruno-Fuge</p>	
<b>Fiscal Impact/Budget Function Code:</b>	N/A	
<b>Policy:</b>	N/A	

<b>District Goal:</b>	Transform our classroom to be truly student-centered through aligned teaching and learning
<b>Administration Recommended Option:</b>	N/A
<b>Motion:</b>	Presentation only
<b>Presenter:</b>	Todd York

# Gifts and Donation - April 19, 2021

Department	Amount being Donated	Entity Donating
Heritage Baseball	\$500 monetary donation	H Squared Field Services
Heritage Baseball	\$85 monetary donation	Danielle Chavez
Heritage Wrestling	American Wrestlers Co. to donate 30 singlets valued at \$60/each (\$1,800 total) to Heritage Wrestling.	American Wrestlers Co
McClatchey Elementary	\$6,000 monetary donation for playground equipment	Gerald and Deborah Zolman (Grandparents of 3 DME students)
Mt. Peak Elem	\$5,000 monetary donation for field day shirts	Mansfield Methodist



---

Minutes of Special Meeting  
The Board of Trustees  
February 8, 2021 / 5:30 pm

**Board Members Present:** Bobby Soto                      Gary Vineyard  
   Heather Prather                      Tami Tobey                      Andrea Walton

**Board Members Absent:** Matt Sanders

**Administration Present:** Courtney Carpenter                      KayLynn Day                      Leslie Garakani  
   Jim Norris                      Karen Fitzgerald

1. FIRST ORDER OF BUSINESS

Announcement by the presiding officer that a quorum of Board members is present, that the meeting has been duly called, and that notice of the meeting has been posted in accordance with the Texas Open Meetings Act, Texas Government Code Chapter 551

The meeting was called to order at 5:37 pm by Vice President, Andrea Walton.

4. PUBLIC COMMENT – Members of the public may address the Board during the public comment portion of the board meeting in accordance with Board policy BED (LOCAL). Individuals wishing to speak shall follow the procedures outlined above  
There was no public comment for this meeting.

2. CLOSED SESSION as authorized by the Texas Open Meetings Act, Texas Government Code Chapter 551.

- A. Consideration of Personnel, Texas Government Codes 551.074 - Resignations, Terminations, and Non-renewals of Professional Employees, Employment, Leaves of Absences, Personnel Issues
- B. Consider Purchase, Exchange, Lease, or Value of Real Property 551.072
- C. Students, Texas Government Code 551.082, 551.0821
  - 1. Discipline Issues
  - 2. Non-Discipline Issues

There was no closed session for this meeting.

3. RECONVENE TO OPEN SESSION  
N/A

5. INFORMATION ITEMS

- A. Consider Curriculum and Instruction Transition & Universal Screener Update  
Shelle Blaylock provided a review of the first 30 days organizational change in the

Department of Learning including outcomes and priorities.

B. Consider BrightBytes Data

The Department of Learning shared an update on the data provided from the November, 2020 survey which assists district leaders in determining how technology purchases are impacting instruction using Clarity’s research-based CASE framework (ISTE Standards).

This learning analytics tool collects data from administrators, teachers, students, and parents in the areas of: classroom, access, skills, and environment. This tool provides evidence-based, research-driven recommendations for allocating technology resources for maximum impact.

C. Consider and Discuss YouthTruth Survey Review

YouthTruth provided an overview on the results from the survey that was distributed in November 2020.

6. DISCUSSION / ACTION ITEMS

A. Consider Update on Incoming Freshman Class of 2021/2022 Based on Zoning Options  
Administration discussed information relating to rezoning options for 2021/2022.

B. Action, if any, on Items Discussed in Closed Session  
N/A

7. ADJOURNMENT OF MEETING

The meeting adjourned at 7:47 p.m.

---

Board President

---

Board Secretary

---

April 19, 2021

Date

---

Minutes of Special Meeting  
The Board of Trustees  
March 22, 2021 / 5:00 pm

<b>Board Members Present:</b>	Matt Sanders Heather Prather	Bobby Soto Tami Tobey	Gary Vineyard Andrea Walton
<b>Administration Present:</b>	Courtney Carpenter Jim Norris	KayLynn Day Karen Fitzgerald	Leslie Garakani

**1. CALL TO ORDER**

- A. Announcement by the presiding officer that a quorum of Board members is present, that the meeting has been duly called, and that notice of the meeting has been posted in accordance with the Texas Open Meetings Act, Texas Government Code Chapter 551

The meeting was called to order at 5:00 pm

The Board moved out of open session at 5:00 pm and into closed session at 5:05 pm. under Texas Government Code Chapter 551.071, 551.082, and 551.0821.

**2. CLOSED SESSION as authorized by the Texas Open Meetings Act, Texas Government Code Chapter 551.**

- A. Consideration of Personnel, Texas Government Codes 551.074 - Resignations, Terminations, and Non-renewals of Professional Employees, Employment, Leaves of Absences, Personnel Issues
- B. Consider Purchase, Exchange, Lease, or Value of Real Property 551.072
- C. Students, Texas Government Code 551.082, 551.0821
1. Discipline Issues
  2. Non-Discipline Issues
- D. Consultation with legal counsel regarding Superintendent Search process and related matters, pursuant to Tex. Gov't Code 551.071, 551.129.
- E. Consider Safety and Security Update, Texas Government Code

The Board moved out of closed session at 5:17 pm.

**3. RECONVENE TO OPEN SESSION**

The Board reconvened in open session at 6:00 pm.

**4. INTRODUCTION OF MEETING**

- A. Invocation  
The invocation was given by Bobby Soto.
- B. Pledges of Allegiances - Irvin Elementary

The pledges of allegiance were led virtually by the Irvin Elementary Ambassadors.

5. Board Receives Information from Student Representatives for Superintendent Search  
MHS and Heritage High School student leaders shared via a recorded message thoughts about characteristics they would like to see in the next superintendent.
6. PRESENTATIONS / RECOGNITIONS
  - A. PCAT Bus Driver of the Year Award  
Jackie Fontaine was recognized as the MISD nominee for the PCAT Bus Driver of the Year.
  - B. College Board Counselor Recognition of Heritage High School Counselor  
Tiffany Gomez, Heritage High School Counselor was nominated for the College Board Counselor Recognition program.
  - C. MHS Debate National Qualifiers  
Midlothian High School's Debate Team had all four Public Forum teams advance to the end of the tournament, and they were four of the top six teams. David Salazar and Jace Martin finished 2nd and are qualified for Nationals; Trevor Tobey and Jade Young finished 4th and are the 1st alternate to nationals; Caeleb Bridgins and Danna Bustos finished 5th and are the 2nd alternate to nationals.
  - D. Magellan Award for Destination Imagination  
Micah Moss was recognized for earning the Magellan Award for Destination Imagination.
  - E. Recognition of Heritage High School State Qualifying Swimmer  
Jaxon Chambers was recognized for qualifying for the Texas State Swim Meet where he placed 15<sup>th</sup> in the 5A 200-freestyle event.
  - F. Heritage High School Girls' Basketball Team, Regional Semi-Finals  
Heritage High School Girls' Basketball Team advanced to the regional semi-final game. Several team members earned All-District awards for outstanding work:  
MVP – Jerzie Bryant; Coach of the Year – Angie Evans; 1<sup>st</sup> Team-Elizabeth Schmidt, Elise Stafford, and Kora Huff; 2<sup>nd</sup> Team: Madeline Bruman and Grace Sweeney; Honorable Mention: Ivy Preusser and Cayla Williams; Academic All District – Asia Purnell, Megan Hill, Elisabeth Schmidt, Ivy Preusser, Cayla Williams, Elise Stafford, Kylar Kenter, Madeline Berumen, and Kora Huff
  - G. Heritage High School All State Band and Choir Students  
Heritage High School Band students, Kamryn Potter, trumpet, and Brent Penwarden, percussion, are recognized in the top two percent of the state of Texas Band students and Isaac George was named to the TMEA All-State Choir for the second year in a row.
7. PUBLIC COMMENT - Members of the public may address the Board during the public comment portion of the board meeting in accordance with Board policy BED (LOCAL). Individuals wishing to speak shall follow the procedures outlined above
  - Shannon Hamilton, 317 Covington Lane, Ovilla, Texas 76064, spoke in support of keeping the mask policy.
  - Tammy Wimbish, 1465 Black Champ Road, Midlothian, Texas 76065, spoke regarding the face mask requirements and parameters for wearing masks.
  - Cary Wimbish, 1465 Black Champ Road, Midlothian, Texas 76065, addressed the Board asking that the community have the freedom to decide whether to wear masks or not.
  - Ashley Brickett, 5221 Shallow Creek Court, Midlothina, Texas, 76065, shared parents should

make the decision relating to students wearing masks.

- Lisa Cook, 1418 Plum Creek Drive, Midlothian, Texas, 76065, spoke in support of keeping the current mask requirements.
- Alana Cook, spoke in support of keeping the current mask requirements.
- Timothy Fitten, 3022 Le Manns Street, Midlothian, Texas 76065, addressed the review of policies.

## 8. CONSENT AGENDA

### A. Consider Meeting Minutes

1. February 8, 2021 - Special Meeting Minutes
2. February 22, 2021 - Regular Meeting Minutes
3. March 3, 2021 - Special Meeting Minutes

### B. Consider Budget Amendments

### C. Consideration of TASB Fuel Contract

### D. Consider Extension of Depository Contract

### E. Consider to Approve Pool of Architectural & Engineering Services RFQ 2021-014

### F. Consideration and approval of 2021-016 Marquee Maintenance at Longbranch & Mt. Peak Elementary

### G. Consideration of Interlocal Agreement between Midlothian ISD and the City of Midlothian for Roadway Facilities and Water Line Improvements for Elementary #8

### H. Consider and Approve Waivers Related to Winter Storm 2021

### I. Consider Approving Administrator Contracts for 2021-22

### J. Consider Food Service Management Company Contract Renewal for 21-22

### K. Consider Approval of Gifts and/or Donations

Andrea Walton asked to pull Items G and K.

Tami Tobey moved, seconded by Gary Vineyard, to approve the consent agenda as presented with the exception of Items G and K. The motion passed with a vote of 6-0.

### G. Consideration of Interlocal Agreement between Midlothian ISD and the City of Midlothian for

Roadway Facilities and Water Line Improvements for Elementary #8

Andrea Walton moved, seconded by Bobby Soto, to approve the Interlocal Agreement for Roadway Facilities and Water Line Improvements between the City of Midlothian and MISD for the Elementary #8 school site. The motion passed with a vote of 6-0.

### K. Consider Approval of Gifts and/or Donations

Andrea Walton moved, seconded by Tami Tobey, to approve the gifts and donations as presented. The motion passed with a vote of 6-0.

## 9. INFORMATION ITEMS

### A. Consider Student Dress Code for 2021-2022

Al Hemmle presented information related to the 2021/2022 Student Dress Code noting that there are no revisions being suggested for the upcoming school year.

### B. Review SwagIt Video Streaming Contract

Leslie Garakani shared contract specifics with viewership, potential budget impact and number of meetings utilized with the SwagIt company over the last year.

C. Consider Approving Staff Positions for 2021/2022

KayLynn Day provided information on projected staff positions for the 2021/2022 school year.

D. Review of Facilities Use Policy - GKD Policy

KayLynn Day, Jim Norris, and Todd York spoke to the current GKD Policy and availability for community use.

E. Review Emergency Preparedness Plan

Commander Tim Hicks and Rola Fadel were available to answer questions related to the recent winter storm and the preparedness for future events.

10. DISCUSSION/ACTION ITEMS

A. Consider COVID Protocols Update on Quarantine Period, TEA Mask Mandates, and Qualifications for Virtual Learning

Gary Vineyard moved, seconded by Tami Tobey, to approve the District Administration's recommendation to reduce the required quarantine time for students and staff exposed to COVID-19 to 10 days without symptoms, effective immediately. The motion passed with a vote of 6-0.

B. Consider December EOC Results

Aaron Williams presented the EOC Results for December 2020.

C. Consider YMCA MOU

Heather Prather moved, seconded by Gary Vineyard, to approve the YMCA MOU as presented. The motion passed with a vote of 6-0.

D. Consider and Determine Climate Survey Dates

Heather Prather moved, seconded by Gary Vineyard, to approve scheduling the Youth Truth climate distribution from May to November with the next distribution dates in November 2021. The motion passed with a vote of 6-0.

E. Consider and Select Diversity Equity and Inclusion Consultant

Action on this item postponed to April 19, 2021 regular meeting.

F. Consider Servant Leader Award and Selection of Committee Members

Tami Tobey moved, seconded by Andrea Walton, to approve Heather Prather, Gary Vineyard, and Bobby Soto as the Servant Leader subcommittee for 2021 selection.

G. Board Subcommittee Reporting

- Andrea Walton shared from the recent School/City Committee that the Mayor and several council members are looking for dates for a joint guiding principles workshop

either the first week of June or the third week of July.

- Heather Prather shared information about the most recent Star Patrol and the hiring of Sheri Brezeael as the new MEF Executive Director.

H. Consider Agenda Items/Topics for Upcoming Meetings

- Update on JROTC program – Gary Vineyard
- 2021 Graduation Plans – Andrea Walton

I. Action, if any, on Items Discussed in Closed Session

J. Superintendent's Report and Announcements

1. Business Reports

9. ADJOURNMENT OF MEETING

The meeting adjourned at 10:05 pm.

\_\_\_\_\_  
Board President

\_\_\_\_\_  
Board Secretary

April 19, 2021

\_\_\_\_\_  
Date

---

Minutes of Special Meeting  
The Board of Trustees  
March 29, 2021 / 4:00 pm

**Board Members Present:** Matt Sanders Bobby Soto Gary Vineyard  
Heather Prather Tami Tobey Andrea Walton

**Superintendent Search Firm:** Dr. Ann Dixon Dr. Karen Rue

1. FIRST ORDER OF BUSINESS

Announcement by the presiding officer that a quorum of Board members is present, that the meeting has been duly called, and that notice of the meeting has been posted in accordance with the Texas Open Meetings Act, Texas Government Code Chapter 551

The meeting was called to order at 4:08 p.m.

2. PUBLIC COMMENT - Members of the public may address the Board during the public comment portion of the board meeting in accordance with Board policy BED (LOCAL). Individuals wishing to speak shall follow the procedures outlined above.

There was no public comment for this meeting.

The Board moved out of open session and into closed session at 4:08 p.m. under Texas Government Codes 551.074, 551.071 and 551.129.

3. CLOSED SESSION as authorized by the Texas Open Meetings Act, Texas Government Code Chapter 551.

A. Review, consider and discuss applicants for the superintendent position, pursuant to Texas Government code 551.074

B. Consultation with legal counsel regarding issues related to superintendent search process, pursuant to Texas Government Code 551.071, 551.129

The Board met with the Superintendent Search Firm to review the applications submitted for Midlothian ISD Superintendent of Schools.

4. RECONVENE TO OPEN SESSION

The Board moved out of closed session and into open session at 12:15 a.m.

5. DISCUSSION/ACTION ITEMS

A. Take action, if any, regarding Superintendent Search process

Andrea Walton moved, seconded by Matt Sanders, to authorize the search firm to take the next steps moving forward for a background check, and to contact or identify the candidates for interview. The motion passed with a vote of 6-0.

7. ADJOURNMENT OF MEETING  
The meeting adjourned at 12:15 a.m.

---

Board President

---

Board Secretary

April 19, 2021

---

Date

---

Minutes of Special Meeting  
The Board of Trustees  
April 5, 2021 / 4:00 pm

**Board Members Present:** Matt Sanders Bobby Soto Gary Vineyard  
Heather Prather Tami Tobey Andrea Walton

**Superintendent Search Firm:** Dr. Ann Dixon

1. FIRST ORDER OF BUSINESS

Announcement by the presiding officer that a quorum of Board members is present, that the meeting has been duly called, and that notice of the meeting has been posted in accordance with the Texas Open Meetings Act, Texas Government Code Chapter 551

The meeting was called to order at 4:00 p.m.

2. PUBLIC COMMENT - Members of the public may address the Board during the public comment portion of the board meeting in accordance with Board policy BED (LOCAL). Individuals wishing to speak shall follow the procedures outlined above.

There was no public comment for this meeting.

The Board moved out of open session and into closed session at 4:01 p.m. under Texas Government Codes 551.074, 551.071 and 551.129.

3. CLOSED SESSION as authorized by the Texas Open Meetings Act, Texas Government Code Chapter 551.

A. Conduct interviews of applicants for superintendent position, and consider and discuss same, pursuant to Tex. Gov't Code 551.074

The Board interviewed applicants for MISD Superintendent position.

B. Consultation with legal counsel regarding issues related to superintendent search process, pursuant to Texas Government Code 551.071, 551.129

4. RECONVENE TO OPEN SESSION

The Board moved out of closed session and into open session at 7:46 p.m.

5. DISCUSSION/ACTION ITEMS

A. Take action, if any, regarding Superintendent Search process

No action taken.

7. ADJOURNMENT OF MEETING  
The meeting adjourned at 7:46 p.m.

---

Board President

---

Board Secretary

April 19, 2021

---

Date

---

Minutes of Special Meeting  
The Board of Trustees  
April 6, 2021 / 4:00 pm

**Board Members Present:** Matt Sanders Bobby Soto Gary Vineyard  
Heather Prather Tami Tobey Andrea Walton

**Superintendent Search Firm:** Dr. Ann Dixon

1. FIRST ORDER OF BUSINESS

Announcement by the presiding officer that a quorum of Board members is present, that the meeting has been duly called, and that notice of the meeting has been posted in accordance with the Texas Open Meetings Act, Texas Government Code Chapter 551

The meeting was called to order at 4:00 p.m.

2. PUBLIC COMMENT - Members of the public may address the Board during the public comment portion of the board meeting in accordance with Board policy BED (LOCAL). Individuals wishing to speak shall follow the procedures outlined above.

There was no public comment for this meeting.

The Board moved out of open session and into closed session at 4:01 p.m. under Texas Government Codes 551.074, 551.071 and 551.129.

3. CLOSED SESSION as authorized by the Texas Open Meetings Act, Texas Government Code Chapter 551.

A. Conduct interviews of applicants for superintendent position, and consider and discuss same, pursuant to Tex. Gov't Code 551.074

The Board interviewed applicants for MISD Superintendent position.

B. Consultation with legal counsel regarding issues related to superintendent search process, pursuant to Texas Government Code 551.071, 551.129

4. RECONVENE TO OPEN SESSION

The Board moved out of closed session and into open session at 10:20 p.m.

5. DISCUSSION/ACTION ITEMS

A. Take action, if any, regarding Superintendent Search process

No action taken.

7. ADJOURNMENT OF MEETING

The meeting adjourned at 10:20 p.m.

---

Board President

---

Board Secretary

April 19, 2021

---

Date

---

Minutes of Special Meeting  
The Board of Trustees  
April 7, 2021 / 4:00 pm

**Board Members Present:** Matt Sanders Bobby Soto Gary Vineyard  
Heather Prather Tami Tobey Andrea Walton

**Superintendent Search Firm:** Dr. Ann Dixon

1. FIRST ORDER OF BUSINESS

Announcement by the presiding officer that a quorum of Board members is present, that the meeting has been duly called, and that notice of the meeting has been posted in accordance with the Texas Open Meetings Act, Texas Government Code Chapter 551

The meeting was called to order at 4:04 p.m.

2. PUBLIC COMMENT - Members of the public may address the Board during the public comment portion of the board meeting in accordance with Board policy BED (LOCAL). Individuals wishing to speak shall follow the procedures outlined above.

There was no public comment for this meeting.

The Board moved out of open session and into closed session at 4:01 p.m. under Texas Government Codes 551.074, 551.071 and 551.129.

3. CLOSED SESSION as authorized by the Texas Open Meetings Act, Texas Government Code Chapter 551.

A. Conduct interviews of applicants for superintendent position, and consider and discuss same, pursuant to Tex. Gov't Code 551.074

The Board interviewed applicants for MISD Superintendent position.

B. Consultation with legal counsel regarding issues related to superintendent search process, pursuant to Texas Government Code 551.071, 551.129

4. RECONVENE TO OPEN SESSION

The Board moved out of closed session and into open session at 7:52 p.m.

5. DISCUSSION/ACTION ITEMS

A. Take action, if any, regarding Superintendent Search process

No action taken.

B. Consider and take possible action to name lone finalist for Superintendent position  
No action taken.

7. ADJOURNMENT OF MEETING  
The meeting adjourned at 7:52 p.m.

---

Board President

---

Board Secretary

April 19, 2021  
Date

---

---

Minutes of Special Meeting  
The Board of Trustees  
April 8, 2021 / 4:00 pm

**Board Members Present:**      Matt Sanders                      Bobby Soto                      Gary Vineyard  
   Heather Prather                      Tami Tobey                      Andrea Walton

**Superintendent Search Firm:**    Dr. Ann Dixon

1. FIRST ORDER OF BUSINESS

Announcement by the presiding officer that a quorum of Board members is present, that the meeting has been duly called, and that notice of the meeting has been posted in accordance with the Texas Open Meetings Act, Texas Government Code Chapter 551

The meeting was called to order at 4:14 p.m.

2. PUBLIC COMMENT - Members of the public may address the Board during the public comment portion of the board meeting in accordance with Board policy BED (LOCAL). Individuals wishing to speak shall follow the procedures outlined above.

There was no public comment for this meeting.

The Board moved out of open session and into closed session at 4:14 p.m. under Texas Government Codes 551.074, 551.071 and 551.129.

3. CLOSED SESSION as authorized by the Texas Open Meetings Act, Texas Government Code Chapter 551.

A. Conduct interviews of applicants for superintendent position, and consider and discuss same, pursuant to Tex. Gov't Code 551.074

The Board interviewed second round applicants for MISD Superintendent position.

B. Consultation with legal counsel regarding issues related to superintendent search process, pursuant to Texas Government Code 551.071, 551.129

4. RECONVENE TO OPEN SESSION

The Board moved out of closed session and into open session at 9:03 p.m.

5. DISCUSSION/ACTION ITEMS

A. Take action, if any, regarding Superintendent Search process

No action taken.

B. Consider and take possible action to name lone finalist for Superintendent position  
No action taken.

7. ADJOURNMENT OF MEETING  
The meeting adjourned at 9:03 p.m.

---

Board President

---

Board Secretary

April 19, 2021  
Date

---

---

Minutes of Special Meeting  
The Board of Trustees  
April 9, 2021 / 4:00 pm

**Board Members Present:** Matt Sanders Bobby Soto Gary Vineyard  
Heather Prather Tami Tobey Andrea Walton

**Lone Finalist:** Dr. Joann Fey

1. FIRST ORDER OF BUSINESS

Announcement by the presiding officer that a quorum of Board members is present, that the meeting has been duly called, and that notice of the meeting has been posted in accordance with the Texas Open Meetings Act, Texas Government Code Chapter 551  
The meeting was called to order at 4:02 p.m.

2. PUBLIC COMMENT - Members of the public may address the Board during the public comment portion of the board meeting in accordance with Board policy BED (LOCAL). Individuals wishing to speak shall follow the procedures outlined above.  
There was no public comment for this meeting.

3. CLOSED SESSION

A. Conduct interviews of applicants for superintendent position, and consider and discuss same, pursuant to Tex. Gov't Code 551.074  
1. Consultation with legal counsel regarding issues related to superintendent search process, pursuant to Texas Government Code 551.071, 551.129  
The Board did not convene into closed session for this meeting.

4. RECONVENE TO OPEN SESSION  
N/A

5. DISCUSSION/ACTION ITEMS

A. Consider and take possible action to name lone finalist for Superintendent position  
Heather Prather moved, seconded by Tami Tobey, to name Dr. JoAnn Fey as the Lone Finalist for Midlothian ISD Superintendent of Schools. The motion passed with a vote of 6-0.

6. ADJOURNMENT OF MEETING  
The meeting adjourned at 4:08 pm.

---

Board President

---

Board Secretary

---

April 19, 2021

Date

**Midlothian I.S.D. School Board Agenda Item Detail**  
**L.A. Mills Administrative Complex Boardroom**

<b>Board Meeting Date:</b>	<b>April 19, 2021</b>	
<b>Item:</b>	<b>Quarterly Investment Report</b>	
<b>Supporting Document(s):</b>	Electronic: Yes <input checked="" type="checkbox"/> No <input type="checkbox"/>	Hard Copy: Yes <input type="checkbox"/> No <input checked="" type="checkbox"/>
<b>Background Information:</b>	<p>Board Policy CDA (LEGAL) requires the District investment officer to prepare a written report of investment transactions for all funds covered under the Public Funds Investment Act. This report shall be presented to the Board and Superintendent not less than quarterly, within a reasonable time after the end of the period:</p> <ul style="list-style-type: none"> <li>• Total Cash Balances increased slightly from last quarter due to the collection of current year taxes.</li> <li>• Total Interest earned this quarter was \$19,250.83 which is less than the prior quarter by \$25,971.22 primarily due to lower interest rates due to the economic results of COVID19. The cash balance increased by approximately \$1.1 million due to the collection of current year taxes.</li> <li>• The decrease in interest rates are as follows- Lone Star rates decreased from last quarter from 0.075% to 0.030%, TexPool rates decreased from 0.116% to 0.047% and First Financial decreased from 0.086% to 0.061%.</li> </ul> <p>A detailed report is presented covering the quarter beginning January 1, 2021 and ending March 31, 2021.</p>	
<b>Fiscal Impact/Budget Function Code:</b>	None	
<b>Policy:</b>	CDA (LEGAL)	
<b>District Goal:</b>	Facilitate budget process and building designs through allocated district resources that foster flexible and innovative learning spaces.	
<b>Administration Recommended Option:</b>	The Administration recommends the Board approve the quarterly investment report as presented.	
<b>Motion:</b>	Presented as a consent Item: If the item is pulled from the consent agenda, the motion might be: "I move that the quarterly investment report be approved as presented."	
<b>Presenter:</b>	Jim Norris	

**Midlothian ISD Investments**  
01/01/21-03/31/21

	Balance at 01/01/21	Deposits	Withdrawals	Interest	Balance at 03/31/21	Fund Totals	First Financial Checking & MMA	Lone Star	TexPool	Total
<b>Fund 163 Payroll</b>										
Checking Account-FFB	55,690.97	18,058,903.74	(18,050,679.34)	113.38	64,028.75	64,028.75	64,028.75			
						64,028.75				
<b>Fund 199 General Fund</b>										
Worker Comp Checking Account-FFB	49.05	100.00	(107.00)	0.00	42.05		42.05			
Lone Star Investment Pool	20,121,164.28	30,304,349.20	(29,300,000.00)	1,703.25	21,127,216.73			21,127,216.73		
TexPool	19,790,535.94	8,113,562.67	(561,522.41)	2,551.48	27,345,127.68				27,345,127.68	
						48,472,386.46				
<b>Fund 240 Food Service</b>										
Money Market account-FFB	47,356.76	125,049.30	0.00	15.65	172,421.71		172,421.71			
TexPool	520,882.59	320,912.65	0.00	63.16	841,858.40				841,858.40	
						1,014,280.11				
<b>Fund 461 Campus Activity</b>										
TexPool	753,523.05	29,973.35	0.00	88.83	783,585.23				783,585.23	
						783,585.23				
<b>Fund 499 Child Care</b>										
TexPool	136,712.65	26,391.41	(1,818.35)	16.66	161,302.37				161,302.37	
						161,302.37				
<b>Fund 599 Interest &amp; Sinking (Debt Service)</b>										
Lone Star Investment Pool	11,342,773.06	16,684,820.20	(14,700,000.00)	929.54	13,328,522.80			13,328,522.80		
TexPool	9,057,195.71	14,883,245.00	(21,138,052.10)	928.87	2,803,317.48				2,803,317.48	
						16,131,840.28				
<b>Fund 694 Construction</b>										
2017 Bonds Retainage	766,125.65	230,545.00	(139.93)	97.63	996,628.35					
2018 Series	5,164,146.56	0.00	(478,892.97)	583.82	4,685,837.41					
2020 Series	102,817,208.33	2,139.93	(5,390,239.08)	11,752.62	97,440,861.80				103,123,327.56	
						103,123,327.56				
<b>Multi-fund Checking Account</b>										
First Financial	323,644.36	45,345,355.52	(43,380,240.15)	405.94	2,289,165.67		2,289,165.67			
						2,289,165.67				
<b>TOTALS</b>	<u>170,897,008.96</u>	<u>134,125,347.97</u>	<u>(133,001,691.33)</u>	<u>19,250.83</u>	<u>172,039,916.43</u>	<u>172,039,916.43</u>	<u>2,525,658.18</u>	<u>34,455,739.53</u>	<u>135,058,518.72</u>	<u>172,039,916.43</u>
							0.061%	0.030%	0.047%	

The investments listed above comply with the District's investment policy as defined in CDA (Local) and with relevant provisions of the Government Code, Chapter 2256.

Prepared by:

  
Dr. Courtney Carpenter, Interim Superintendent

  
Jim Norris, Asst. Superintendent  
for Finance and Operations

**Midlothian I.S.D. School Board Agenda Item Detail**  
**L.A. Mills Administrative Complex Boardroom**

<b>Board Meeting Date:</b>	<b>April 19, 2020</b>
<b>Item:</b>	<b>Requisitions over \$50,000</b>
<b>Supporting Document(s):</b>	Electronic: Yes <input checked="" type="checkbox"/> No <input type="checkbox"/> Hard Copy: Yes <input type="checkbox"/> No <input checked="" type="checkbox"/>
<b>Background Information:</b>	<p>The Board delegates to the Superintendent or designee the authority to make budgeted purchases for goods or services. However, any single, budgeted purchase of goods or services that costs \$50,000 or more, regardless of whether the goods or services are competitively purchased, shall require Board approval before a transaction may take place.</p> <p>The following:</p> <ul style="list-style-type: none"> <li>• Daktronics – Control Systems upgrade for MISD MultiPurpose Stadium – General Fund - \$120,437.00 (must use this vendor to be compatible with Daktronics videoboard and computer system is running off Windows 7 which is no longer supported)</li> <li>• Grande Truck Center – Purchase of additional F750 24’ Box Truck – General Fund - \$76,653 (3 Buyboard vendors were contacted, 2 provided quotes – 1 could not provide equipment before year end; this was the lowest of the 2 quotes)</li> <li>• Longhorn Bus Sales – Purchase 3 Special Education buses for growing student enrollment – General Fund (fund balance may need to be used if in class enrollment drops below 80% during the 6<sup>th</sup> 6 weeks) – \$300,737 – 2 Buyboard vendors were contacted, this vendor was the lowest bid and can provide the buses before June 30.</li> </ul>
<b>Fiscal Impact/Budget Function Code:</b>	These requisitions are budgeted from the General Fund.
<b>Policy:</b>	CH (Local)
<b>District Goal:</b>	Facilitate budget process and building designs through allocated district resources that foster flexible and innovative learning spaces.
<b>Administration Recommended Option:</b>	It is the Administration’s recommendation that the requisitions of \$50,000 or over be approved.
<b>Motion:</b>	Presented as a consent item. If the item is pulled from the consent agenda, the motion might be: “I make a motion to approve the requisitions of \$50,000 or over as presented.”
<b>Presenter:</b>	Jim Norris

REQ DATE

03/25/2021

REQUISITION NUMBER

0000098813

PRINTED 03/25/2021

VENDOR KEY : DAKTRONI000  
 SHIP DATE : 03/25/2021  
 FISCAL YEAR : 2020-2021  
 ENTERED BY : VOLENSHA001  
 ORIGINAL REQ # : 0000098813

**VENDOR:**  
 DAKTRONICS INC  
 201 DAKTRONICS DR  
 BROOKINGS, SD 57006

**SHIP TO:**  
 MIDLOTHIAN I.S.D.  
 100 WALTER STEPHENSON ROAD  
 MIDLOTHIAN, TX 76065

PHONE: (972) 480-9396

ATTN: Ron Bland/Stadium

QUANTITY	UNIT	DESCRIPTION OF ITEMS OR MATERIALS	UNIT PRICE	AMOUNT
1		Daktronics Quote 755077-1-REV 0, Buyboard 592-19 vendor  Daktronics Control System Upgrade - MISD MultiPurpose Stadium  Equipment as provided on attached Quote to include: Show Control User-Station - Touchsmart (Qty 2) Show Control Control Server - Rack Mounted (Qty 1) Venus Control Suite Server - Rack Mounted (Qty 1) Buffalo 8TB NAS (Qty 1) DST - Rack Mounted (Qty 1) DMP-8300 Media Player (Qty 2) VP-6000 Video/Display Processor (Qty 2) Raritan Digital MCCAT KVM Base Station (Qty 1) Extended KVM User Station (Monitor/KB/Mouse) (Qty 1) Rack-Mounted KVM User Station (Qty 1) 44RU Rack (Qty 1)  Services included: Onsite Installation & Testing Onsite Operator Training - 2 days Warranty - 1 year Parts & Labor Freight Included  ACCOUNT SUMMARY (FOR INTERNAL USE) ACCOUNT NUMBER ACCOUNT AMOUNT	120347.00000	120,347.00
CONTINUED ON NEXT PAGE			<b>PAGE TOTAL</b>	120,347.00
			<b>TOTAL</b>	120,347.00

This is a Requisition and not an official Purchase Order.  
 The District is not financially responsible for the  
 unauthorized purchases made with a Requisition.

<b>REQ DATE</b>
<b>03/25/2021</b>

<b>REQUISITION NUMBER</b>
<b>0000098813</b>

PRINTED 03/25/2021

VENDOR KEY : DAKTRONI000  
 SHIP DATE : 03/25/2021  
 FISCAL YEAR : 2020-2021  
 ENTERED BY : VOLENSHA001  
 ORIGINAL REQ # : 0000098813

**VENDOR:**  
 DAKTRONICS INC  
 201 DAKTRONICS DR  
 BROOKINGS, SD 57006

**SHIP TO:**  
 MIDLOTHIAN I.S.D.  
 100 WALTER STEPHENSON ROAD  
 MIDLOTHIAN, TX 76065

PHONE: (972) 480-9396

ATTN: Ron Bland/Stadium

QUANTITY	UNIT	DESCRIPTION OF ITEMS OR MATERIALS	UNIT PRICE	AMOUNT
		199 E 36 6639 00 999 0 99 999 CommCode: Stadium Video Board Hardware	120,347.00	
			<b>PAGE TOTAL</b>	0.00
			<b>TOTAL</b>	120,347.00

This is a Requisition and not an official Purchase Order.  
 The District is not financially responsible for the  
 unauthorized purchases made with a Requisition.



**Midlothian ISD**  
100 Walter Stephenson Road  
Midlothian, TX 76065  
Ron Bland  
214-870-1508

755077-1 REV 0  
12-Feb-2021  
Valid for 60 Days  
FCA: Daktronics  
Payment Terms: 30% w/ Order, 60% PBS, 10% N30  
from shipment

RE: Midlothian ISD Stadium – Control Upgrade

Daktronics, Inc. ("Daktronics") appreciates the opportunity to provide a Quote to Midlothian ISD ("Purchaser").

Per your request to upgrade the Daktronics control system at Midlothian ISD Stadium, we are providing the following proposal.

On the computer front, all computers will be updated to new hardware and run the latest versions of Windows 10. This will allow you to continue receiving the latest operating system patches from Microsoft, as well as receive continued software updates from Daktronics. There will be one less computer in the system as the V7Control computer running Venus 7000 will no longer be needed. This is because on the processor front, we will replace the separate VIP-4400 video processors and DI-6000 display processors with the latest-generation combined video & display processor, the VP-6000. Since Venus 7000 is reaching end-of-service-life at the end of 2021, the VIP-4400s need to be removed to keep your control system fully serviceable beyond this year. An additional benefit to removal of the VIP-4400s is that there will be two fewer points of failure in the system and one less software interface to manage. The VP-6000 has four SDI inputs to match the VIP-4400, but also has more advanced video transitions and significantly-increased layout and zoning configurability over the 4400.

In addition to the computers and processors, we are also replacing the KVM system as it is end-of-life with Raritan, as well as replacing the network router and switch with the latest Cisco models. Lastly, we will ship a new control system rack fully assembled and wired by Daktronics manufacturing. This pre-assembly reduces the amount of on-site install time required, which not only provides you with a cleaner rack, but also lowers the overall cost due to less on-site labor.

We look forward to working with you on this upgrade to extend the lifetime of your existing display and to bring the latest control system features to Midlothian ISD Stadium!



## Equipment

Show Control User Station, Touchsmart - QTY 2  
Show Control Server, Rack-Mounted - QTY 1  
Venus Control Suite Server, Rack-Mounted - QTY 1  
Buffalo 8TB NAS - QTY 1  
DSTI, Rack-Mounted - QTY 1  
DMP-8300 Media Player - QTY 2  
VP-6000 Video/Display Processor - QTY 2  
Raritan Digital MCCAT KVM Base Station - QTY 1  
Extended KVM User Station (Monitor/KB/Mouse) - QTY 1  
Rack-Mounted KVM User Station - QTY 1  
44RU Rack - QTY 1

## Services

Onsite Installation & Testing  
Onsite Operator Training – 2 Days  
Warranty – 1 Year Parts & Labor

Freight included

**TOTAL PRICE (EXCLUDING TAXES) \$ 120,347.00**

(amount in USD)

### FIRST YEAR OF SERVICE:

One Year Standard Parts and Labor Warranty DD1425981  
(<http://www.daktronics.com/standardpartsandlabor>) concurrent with One Year Warranty and  
Limitation of Liability

The parties agree that due to the volatile market for materials, including but not limited to steel, copper wire, electrical devices, and other related components, Daktronics reserves the right to adjust the contract price prior to execution of the Quote.

Unless otherwise provided on the attached Installation Responsibilities Checklist, the following are not included: permits, duties, taxes, foundations, structural beams, installation, identification panels, power, conduit, and electrical hookup to the equipment. Taxes: Buyer must provide a

sales tax exemption certificate to claim exemption. Specifications subject to change; refer to shop drawings for exact dimensions prior to construction. This quote is subject to the following:

- [SL-02375 Standard Terms and Conditions of Sale](#)
  - ([http://www.daktronics.com/terms\\_conditions/SL-02375.pdf](http://www.daktronics.com/terms_conditions/SL-02375.pdf))
- [SL-02374 Standard Warranty and Limitation of Liability](#)
  - ([http://www.daktronics.com/terms\\_conditions/SL-02374.pdf](http://www.daktronics.com/terms_conditions/SL-02374.pdf))

Without limiting any other provision in this Agreement, the parties agree that any delays caused directly or indirectly as a result of the COVID-19 pandemic are excusable and will extend the time for performance under this Agreement. Delays may be caused by, without limitation, government mandates, unsafe site conditions, or resource constraints arising out of conformity with CDC guidelines or government mandates.



Michael Cruz  
 Application Engineer  
 817-845-7063  
[Michael.Cruz@Daktronics.com](mailto:Michael.Cruz@Daktronics.com)



Scott Luce  
 Regional Sales  
 972-249-7130  
[Scott.Luce@Daktronics.com](mailto:Scott.Luce@Daktronics.com)

The undersigned has actual authority to execute this document, and Daktronics is relying upon such authority.

**ATTESTATION:**

**PURCHASER:**

By: \_\_\_\_\_ Name/Title: \_\_\_\_\_ Date: \_\_\_\_\_  
 Signature Print or Type

**DAKTRONICS, INC:**

By: \_\_\_\_\_ Name/Title: \_\_\_\_\_ Date: \_\_\_\_\_  
 Signature Print or Type

By: \_\_\_\_\_ Name/Title: \_\_\_\_\_ Date: \_\_\_\_\_  
 Signature Print or Type

Estimated Delivery: 11-13 weeks from quote acceptance.

### INSTALLATION RESPONSIBILITIES CHECKLIST

Responsible Party		Description
Daktronics	Customer	
✓		1. Removal of existing equipment.
	✓	2. Disposal of existing equipment.
✓		3. Generate and issue site specific electrical and signal drawing submittals for equipment.
	✓	4. Unobstructed access to equipment and control room installation site until display is 100%.
✓		5. Site clean-up after Daktronics work.
✓		6. Crating and shipping of all equipment to facility via common or independent carrier.
	✓	7. Accept, lift, unload, and inspect all equipment and control equipment from carrier.
	✓	8. Provide storage of equipment and control equipment in a safe, dry, and secure location until installation.
	✓	9. Communication responsibility (DSL line, Network, Static IP address and associated monthly fees) as necessary for this system. Supply static IP address five (5) days prior to installation.
✓		10. Furnish signal cable as delineated on the quote.
✓		11. Terminate signal cable at control location and Equipment.
	✓	12. Provide climate controlled, secured control room for all control systems (on/off venue site). Control room is to be climate controlled by Customer. Normal operating temperature should be between 65 and 75 degrees Fahrenheit. Normal operating humidity should be less than 80 percent non-condensing. Storage temperature should be between 40 and 95 degrees Fahrenheit. Storage humidity should be less than 95 percent non-condensing.
	✓	13. Provide high speed internet connection to control room equipment.
	✓	14. Required power outlets on clean dedicated circuit(s) for all and control equipment.
✓		15. Unpack, set-up, hook-up, and testing of control system.
✓		16. Provide personnel for maintenance and operator training.
✓		17. Perform final systems testing and commissioning.
✓		18. Final acceptance, per DF-1252.
✓		19. Walk-thru inspection at Substantial Completion and identification of punch list items
✓		20. Completion of punch list items.

NOTE: All change order work performed by Daktronics or Daktronics subcontractor will be performed at cost plus 20% overhead and profit.



[DAKTRONICS.COM](http://DAKTRONICS.COM)

201 Daktronics Drive PO Box 5128  
Brookings, South Dakota 57006-5128  
T 800-325-8766 605-692-0200 F 605-697-4700

Mr. Ron Bland  
Midlothian Independent School District  
923 S. 9<sup>th</sup> St.  
Midlothian, Tx 76065

Dear Mr. Bland,

Due to the proprietary nature of the communication between the Daktronics Video Display and Control System, Daktronics is the only vendor that can offer a control upgrade for your stadium. Any attempt by another vendor to modify the equipment will potentially damage the equipment and void any warranties that may be in effect.

Sincerely,

Chris Westerman  
Daktronics, Inc.  
Product Manager  
Phone: 605-651-3414

<b>REQ DATE</b>
03/31/2021

<b>REQUISITION NUMBER</b>
0000098973

PRINTED 04/01/2021

VENDOR KEY : GRANDE T000  
 SHIP DATE : 03/31/2021  
 FISCAL YEAR : 2020-2021  
 ENTERED BY : TERRYDAW000  
 ORIGINAL REQ # : 0000098973

**VENDOR:**  
 GRANDE TRUCK CENTER  
 4562 IH 10 E  
 SAN ANTONIO, TX 78219

**SHIP TO:**  
 AUXILIARY CENTER  
 601 E AVENUE E  
 MIDLOTHIAN, TX 76065

ATTN: DAWN TERRY

QUANTITY	UNIT	DESCRIPTION OF ITEMS OR MATERIALS	UNIT PRICE	AMOUNT
1	EACH	Buyboard Vendor 601-19 exp 11/29/22 Vehicles, Heavy Duty Trucks, Police Motorcycles, Parts & Service Labor 2019 Ford F750 VIN 1FDWF7DE4KDF12522 Ford F750 Diesel Truck Regular Cab Base (F7D) with Box (Smyrna Truck & Cargo), 6.7L Power Stroke V8 Turbo Diesel - 300 HP, Air Brakes and Maxon Liftgate (Additional information is included in quote paperwork attached)	76253.00000	76,253.00
1	EACH	Buyboard Fee	400.00000	400.00
<b>ACCOUNT SUMMARY (FOR INTERNAL USE)</b>				
		<b>ACCOUNT NUMBER</b>	<b>ACCOUNT AMOUNT</b>	
		199 E 36 6631 00 999 0 99 999	76,653.00	
CommCode: Auto/ Bus Vehicle Purchase				
			<b>PAGE TOTAL</b>	76,653.00
			<b>TOTAL</b>	76,653.00

This is a Requisition and not an official Purchase Order.  
 The District is not financially responsible for the unauthorized purchases made with a Requisition.

# TEXAS LOCAL GOVERNMENT PURCHASING COOPERATIVE

## BUYBOARD

3/31/2021

**PRODUCT PRICING BASED ON CONTRACT**

Customer: Midlothian ISD  
F750 Box Truck

A: Base Price in Bid/Proposal Number 601-19 134 \$ 44,749.00

**B: Published Options (Itemize each item below)**

<u>99E 300 HP</u>	<u>\$ 1,995.00</u>	<u>18D 25999 GWR</u>	<u>\$ 120.00</u>
<u>62G Air Comp</u>	<u>\$ 1,175.00</u>	<u>88R Air Driver Seat</u>	<u>\$ 440.00</u>
<u>41A PTO Prov</u>	<u>\$ 895.00</u>	<u>90P Power Group</u>	<u>\$ 470.00</u>
<u>60C Air Brakes</u>	<u>\$ 1,770.00</u>	<u>586 Radio</u>	<u>\$ 280.00</u>
<u>62D Air dryer</u>	<u>\$ 460.00</u>	<u>21D Sync</u>	<u>\$ 395.00</u>
<u>43P 12K Ft Axle</u>	<u>\$ 625.00</u>	<u>19Y Body Prep</u>	<u>\$ 1,200.00</u>
<u>61D Fl Susp</u>	<u>\$ 322.00</u>	<u>314 Ship Trough</u>	<u>\$ 600.00</u>
<u>18P Drive Shaft Upgrade</u>	<u>\$ 185.00</u>	<u>54F Power Mirror</u>	<u>\$ 365.00</u>
<u>981 Rear Shocks</u>	<u>\$ 165.00</u>	<u>FP Floor Plan</u>	<u>\$ 1,200.00</u>
<u>230WB Wheelbase</u>	<u>\$ 965.00</u>	<u>24 ft Dry Van</u>	<u>\$ 12,816.00</u>
<u>538 HD Frame</u>	<u>490</u>	<u>Maxium Lift Gas</u>	<u>4671</u>
Subtotal Column 1:	<u>\$ 8,947.00</u>	Subtotal Column 2:	<u>\$ 22,557.00</u>

Published Options added to Base Price (Subtotal of "Col 1" + "Col 2") \$ 31,504.00

C: Subtotal of A + B => \$ 76,253.00

D: UnPublished Options \_\_\_\_\_ %

<u>\$ -</u>	<u>\$ -</u>
<u>\$ -</u>	<u>\$ -</u>

Subtotal Column 1: \$ - Subtotal Column 2: \$ -

Body \$ -

E: Contract Price Adjustment (if any, explain here) \$ -

F: Total of C + D + E (Not Including Buy Board Fee) => \$ 76,253.00

G: Quantity Ordered (Units x F) => # of Units 1 \$ 76,253.00

H: BUYBOARD Fee (From Fee Schedules, Table: \_\_\_\_\_ => @ \_\_\_\_\_ % \$ 400.00

I: Non-Equipment Charges & Credits (ie: Ext. Warranty, Trade-In, Cost of Factory trips, etc.)

<u>\$ -</u>	
<u>\$ -</u>	

Subtotal of Non-Equipment Charges \$ -

J: TOTAL PURCHASE PRICE INCLUDING (G + H + I) => \$ 76,653.00

Grande Truck Center  
PO Box 201210  
San Antonio, Texas 78220

Rocky Shoffetail  
PH 210-666-7112  
FX 210-666-7216  
800-779-7672 X112  
3/31/2021

RETAIL SALES ORDER  
PRELIMINARY COPY

**GRANDE TRUCK CENTER**

INTERSTATE 10 AND W.W.WHITE ROAD  
P.O. BOX 201210, SAN ANTONIO, TX 78220  
PHONE: (210) 681-4121

PURCHASER'S NAME	<b>Midlothian ISD</b>	DEAL NO.		DATE	<b>1/28/2021</b>
ADDRESS	<b>100 Walter Stephenson Rd</b>				STOCK NO.
CITY	<b>Midlothian</b>	STATE	<b>TX</b>	ZIP	<b>76065</b>
				PHONE	<b>469-856-5032</b>
PLEASE ENTER BY ORDER FOR THE FOLLOWING MOTOR VEHICLE:					

STOCK NO.  
**19-7115**

YEAR	MAKE	MODEL	COLOR	W.B.	I.D. NO.
<b>2019</b>	<b>Ford</b>	<b>F750</b>			<b>1FDWF7DE4KDF12522</b>

<p>** The Dealer's Inventory Tax charge is intended to reimburse the dealer for ad valorem taxes on its motor vehicle inventory. The charge, which is paid by the dealer to the county tax assessor-collector, is not a tax imposed on a consumer by the government, and is not required to be charged by the dealer to the consumer.</p>	LIST PRICE:	\$	<b>\$0.00</b>
	SALE PRICE	\$	<b>\$78,153.66</b>
	ADDITIONAL EQUIPMENT	\$	<b>\$0.00</b>
	SUB TOTAL	\$	<b>\$78,153.66</b>
	FEDERAL EXCISE TAX	\$	<b>\$0.00</b>
	**DEALER'S INVENTORY TAX	\$	<b>\$0.00</b>
	LESS TRADE-IN ALLOWANCE	\$	<b>\$0.00</b>

0	YEAR	MAKE	LIC. NO.
0			

<b>Total Price Due to Customer</b>	NET DIFFERENCE	<b>\$78,153.66</b>
	STATE & LOCAL TAXES	\$ <b>\$0.00</b>
<b>1 Only Available</b>	LICENSE & BRIDGE FEES	\$ <b>\$0.00</b>
	TITLE FEE	\$ <b>\$0.00</b>
	STATE INSPECTION	\$ <b>\$0.00</b>
	EXTENDED SERVICE PLAN	\$ <b>\$0.00</b>
	MISC CHARGES	\$ <b>\$0.00</b>
	DOCUMENTARY FEE	\$ <b>\$0.00</b>

NEW/USED VEHICLE MILES \_\_\_\_\_

IF SALE IS OF A USED VEHICLE, IT IS SOLD (BOUGHT) AS IS.

DRAFT

A DOCUMENTARY FEE IS NOT AN OFFICIAL FEE. A DOCUMENTARY FEE IS NOT REQUIRED BY LAW BUT MAY BE CHARGED TO BUYERS FOR HANDLING DOCUMENTS AND PERFORMING SERVICES RELATING TO THE CLOSING OF A SALE. A DOCUMENTARY FEE MAY NOT EXCEED \$300 OR A REASONABLE AMOUNT AGREED TO BY THE PARTIES FOR A HEAVY COMMERCIAL VEHICLE CONTRACT. THIS NOTICE IS REQUIRED BY LAW.

	SUB TOTAL	\$	<b>\$78,153.66</b>
LENT TO:	OWING TO:	\$	<b>\$0.00</b>
	ON TRADE		
	<b>Amount Due</b>		<b>\$78,153.66</b>
	CASH DEPOSIT REC. #	\$	<b>\$0.00</b>
	REBATES	\$	<b>(\$1,500.00)</b>
Unpaid Balance - Amount Financed	BALANCE DUE	\$	<b>\$76,653.66</b>

PURCHASER AGREES THAT THIS ORDER INCLUDES ALL OF THE TERMS AND CONDITIONS ON BOTH THE FACE AND REVERSE SIDE HEREOF, THAT THIS ORDER CANCELS AND SUPERSEDES ANY PRIOR AGREEMENT AND AS OF THE DATE HEREOF COMPRISES THE COMPLETE AND EXCLUSIVE STATEMENT OF THE TERMS OF THE AGREEMENT RELATING TO THE SUBJECT BINDING UNTIL ACCEPTED BY THE GENERAL MANAGER OR SALES MANAGER PURCHASER BY HIS EXECUTION OF THIS ORDER ACKNOWLEDGES THAT HE HAS READ ITS TERMS AND CONDITIONS AND HAS RECEIVED A TRUE COPY OF THIS ORDER

IF SALE IS OF A USED VEHICLE, IT IS SOLD (BOUGHT) AS IS. THIS ORDER SHALL NOT BECOME BINDING UNTIL ACCEPTED BY THE GENERAL MANAGER OR SALES MANAGER

COMPANY NAME	<b>Midlothian ISD</b>	ACCEPTED & APPROVED	
PURCHASER'S SIGNATURE		SALESMAN	<b>Rocky Shoffstall</b>

F&L

DEALER 525 909

VIN 1FDMF7DB4KDF12322

	Original Price	Discount	Net Price
P75E REGULAR CAB DOCK HGT	89455.00		89455.00
260" WHEELBASE	9651.00		9651.00
2019 MODEL YEAR			
Y2 OXFORD WHITE			
GE STEEL GRAY VINYL 30/70			
PREFERRED EQUIPMENT PKG. 600A			
.SINGLE, 21X CAP OPEN			
.ENGINE EXHAUST BRAKE			
.FUEL TANK - 50 GALS ALUMINUM			
.REAR SEAT DELETE			
.ARGENT GRILLE			
.AIR CONDITIONING			
.AUXILIARY SWITCH (4)			
.FT W8 22.5X8.25 108 PWD CT DS			
.RH W8 22.5X8.25 108 PT STL DS			
99E 6.7L POWER STROKE DSL 300 HP	1995.00		1761.00
.6 SPEED AUTO TRANS DSL			
TCO GVNR 11R22.5G ENDURAN RGA		NC	NC
X6D 5.50 AXLE RATIO		NC	NC
16V VOLTRON	100.00		88.00
163 RP MARKER/CLEARANCE LIGHTS AMBER		NC	NC
17M BACKUP ALARM, ELECTRIC	110.00		97.00
18D DE-RATE GVNR TO 35,999	120.00		106.00
18P DRIVESHAFT UPGRADE	185.00		164.00
21D SYNC MEDIA SYSTEM	395.00		349.00
41A TRANS POWER TAKE OFF DIESEL	895.00		790.00
41N ENGINE BLOCK HEATER	60.00		53.00
42S 50 STATE EMISSIONS		NC	NC
43P FRONT AXLE - 12K CAPACITY	525.00		464.00
53B FRAME RAILS 10.25 130 PSI	650.00		574.00
54R XL2020 PWR/HTD BLACK 162"	275.00		242.00
55H JUMP START STUD	90.00		80.00
586 PREM ELEC AM/FM/CD/MP3	280.00		247.00
59A AIR HORN	90.00		80.00
59C BODY BUILDER WIRING	135.00		119.00
60A SYNTHETIC FAT WEL BEARING LUBE	50.00		45.00
607 SYN LUBE, REAR AXLE	100.00		88.00
61D FRONT SUSPENSION - 12K CAP	305.00		269.00
62B AIR COMPRESSOR - BENDIX 11.2CF		NC	NC
62D AIR DRYER	460.00		406.00
63B BATTERY - 2 - 12V 1800 CCA	60.00		53.00
67C AIR BRAKES	1770.00		1562.00
G 30/70 AIR RIDE DRIVER VINYL	395.00		349.00
90P POWER EQUIPMENT GROUP	470.00		415.00
951 REAR SHOCK ABSORBERS	165.00		146.00
962 DAYTIME RUNNING LIGHTS	45.00		39.00
DISCOUNTED EQUIPMENT			
GVNR 11R22.5G G182	120.00		106.00
TOTAL OPTIONS/OTHER	10810.00		9544.00
TOTAL VEHICLE & OPTIONS/OTHER	80265.00		70097.00
DESTINATION & DELIVERY	2095.00		2095.00
<b>TOTAL FOR VEHICLE</b>	<b>82360.00</b>		

FUEL CHARGE

37.00

197115

This invoice may not reflect the final cost of the vehicle in view of the possibility of future rebates, allowances, discounts and incentive awards from Ford Motor Company to the dealer.

Sold to		Order Type		Ramp Code	Batch ID	Price Level
Ship to (if other than above)		Date Inv Prepared	Item Number	Transit Days		
Ship Through						
Invoice & Unit Identification NO.	Final Assembly Point	Finance Company and/or Bank				
HB	Invoice Total	A & Z Plan	O Plan	X Plan	FPA	AA

This invoice to be used for the billing of vehicles only

Dealer's copy

DEALER 528 909

VIN 1FDNF7DE4KDF12522

SHIPPING HEIGHT 11819 LBS.

Suggested Retail Price

Final Price

TOTAL

82366.00

72229.08

197115  
STK

This invoice may not reflect the final cost of the vehicle in view of the possibility of future rebates, allowances, discounts and incentive events from Ford Motor Company to the dealer.

Sold to Grande Truck Center 528909 P.O. BOX 201210 San Antonio TX 78220		Order Type 1		Ramp Code CR07		Batch ID KG301		Price Level 950	
Ship to (if other than above) Grande Truck Center 52909 4562 IH 10 East San Antonio TX		Date Inv. Prepared 07 30 19		Item Number 52-7115		Transit Days 01		Ship Through	
Invoice & Unit Identification NO. 1FDNF7DE4KDF12522		Final Assembly Plant OHIO		Finance Company and/or Bank Ford Motor Credit 000001					
HB	Invoice Total	A & Z Plan	D Plan	X Plan	FPA	AA			
2411	72229.08				995.00				

This invoice to be used for the billing of vehicles only

Dealer's copy

**Invoice**

Number 042411



GRANDE TRUCK CENTER  
4562 IH 10 EAST  
SAN ANTONIO, TX 78219  
USA

Smyrna Truck & Cargo  
2158 Atlanta Road  
Smyrna, Georgia 30080

Telephone: 770-433-0112  
Fax: 770-438-1504

Invoice Date 11/15/2019  
Due Date 12/15/2019 NET30  
Sales order SO-045275  
VIN: 1FDWF70E4KDF12522  
Registration PO# 23561  
Your reference  
Our reference Marshall Hale  
Payment NET 30 DAYS  
Invoice account 71468

197115  
13210

Item number	Description	Quantity	Unit	Unit price	Discount	Amount
000186_202	BODY, DRY FREIGHT Quantity: 1.00 Serial number: SO-045275	1.00	ea	14,655.00	0	\$14655.00
BODY	Aluminum Sheet and Post Dry Freight Van Body 24' Length - 102" Height - 102" Width .040" Pre-painted Aluminum Sides Extruded Aluminum Corner Post Galvanized Steel Rear Frame with Integral Rain Gutter	1.00				
ROOFING	Aluminum Tread-Brite Front Radius Cast Aluminum Corner Caps Galvanized Anti-Snag Roof Bows on 24" Centers FMVSS 108 Exterior LED Lights & Reflectors Asphaltic Undercoat -FURNISH & INSTALL A 2500LB. TUCKUNDER LIFTGATE WITH 48X80 STEEL PLATFORM Aluminum 24" x 102"	1.00				
DOOR	102X102 BODY PREMIUM PLASTIC 94 INCH WIDE X 95.875 INCH HIGH 2132 DOOR	1.00				
FLOORING	1.125" Laminated Hardwood Floor 24' Length 102" Width	1.00				
POST	Front Wall 1.375 Galvanized Steel Z-Post	1.00				
SIDE WALL POSTS	1.375" Galvanized Steel 16" Centers for 24' L x 102" H Body	1.00				
LIGHT KIT	RECESSED LIGHT KIT	1.00				
LINING	E-Track 2 Rows 24' Length -MOUNT AT 30" & 48" CA	1.00				

**Invoice**

Number 042411



POST	2 LIGHT 12GA X 11.1875 X 106.25 CURBSIDE GALVANNEALED CORNER POST	1.00
POST	2 LIGHT 12GA X 11.1875 X 106.25 ROADSIDE GALVANNEALED CORNER POST	1.00
SIDE LIN. PLY UNI 3/	SIDE LIN. PLY UNI 3/8X102X20	1.00
FRONT LINING	PLYWOOD 1/2 INCH 102" Height 102" Width	1.00
SUB FRAME	FordIft Package 102" Width	1.00
THRESHOLD	WIDE 1 INCH GALVANIZED THRESHOLD	1.00
LIGHT KIT	RECESSED LIGHT KIT	1.00
BACK UP ALARM	STANDARD BACK UP ALARM	1.00
LIGHT	DOME LIGHT W/ REAR MOUNT SWITCH	2.00
GRAB HANDLE	CURBSIDECHROME GRAB HANDLE	1.00
GRAB HANDLE	ROADSIDECHROME GRAB HANDLE	1.00
MUD FLAP	24 INCH X 36 INCH SMYRNA CARGO MUD FLAP -WEIGHT TICKET & CERTIFICATION -DELIVERY TO GRANDE FORD	1.00
LIFTGATE	Maxon TE-25 Tuck-A-Way 2500lbs. Capacity 48" x 78.5" +Wedge Steel Platform Serial Number: 1910526106	1.00

Sales subtotal amount	Total discount	Total charges	Net amount	Sales tax	Round-off	Total
14,655.00	0.00	250.00	14,905.00	0.00	0.00	14,905.00 USD

# Invoice

Number 042412



GRANDE TRUCK CENTER  
4562 IH 10 EAST  
SAN ANTONIO, TX 78219  
USA

Smyrna Truck & Cargo  
2158 Atlanta Road  
Smyrna, Georgia 30080

Telephone: 770-433-0112  
Fax: 770-438-1504

Invoice Date 11/15/2019  
Due Date 12/15/2019 NET30  
Sales order SO-045276  
VIN: 1FOWF7DE6KDF12S23  
Requisition PO# 23562  
Your reference  
Our reference Marshall Hale  
Payment NET 30 DAYS  
Invoice account 71468

Item number	Description	Quantity	Unit	Unit price	Discount	Amount
000166_202	BODY, DRY FREIGHT Quantity: 1.00 Serial number: SO-045276	1.00	ea	14,655.00	0	\$14655.00
BODY	Aluminum Sheet and Post Dry Freight Van Body 24' Length - 102" Height - 102" Width .040" Pre-painted Aluminum Sides Extruded Aluminum Corner Post Galvanized Steel Rear Frame with Integral Rain Gutter  Aluminum Tread-Brick Front Radius Cast Aluminum Corner Caps Galvanized Anti-Snag Roof Bows on 24" Centers FMVSS 108 Exterior LED Lights & Reflectors Asphaltic Undercoat -FURNISH & INSTALL A 2500LB. TUCKUNDER LIFTGATE WITH 48X80 STEEL PLATFORM	1.00				
ROOFING	Aluminum 24" x 102"	1.00				
DOOR	102X102 BODY PREMIUM PLASTIC 94 INCH WIDE X 96.875 INCH HIGH 2132 DOOR	1.00				
FLOORING	1.125" Laminated Hardwood Floor 24' Length 102" Width	1.00				
POST	Front Wall 1.375 Galvanized Steel Z-Post	1.00				
SIDE WALL POSTS	1.375" Galvanized Steel 16" Centers for 24'L x 102"H Body	1.00				
LIGHT KIT	RECESSED LIGHT KIT	1.00				
LINING	E-Track 2 Rows 24' Length -MOUNT AT 30" & 48" CAL	1.00				

**Invoice**

Number 042412



POST	2 LIGHT 12GA X 11.1875 X 106.25 CURBSIDE GALVANNEALED CORNER POST	1.00
POST	2 LIGHT 12GA X 11.1875 X 106.25 ROADSIDE GALVANNEALED CORNER POST	1.00
SIDE LIN. PLY UNI 3/	SIDE LIN. PLY UNI 3/8X102X20	1.00
FRONT LINING	PLYWOOD 1/2 INCH 102" Height 102" Width	1.00
SUB FRAME	Forklift Package 102" Width	1.00
THRESHOLD	WIDE 1 INCH GALVANIZED THRESHOLD	1.00
LIGHT KIT	RECESSED LIGHT KIT	1.00
BACK UP ALARM	STANDARD BACK UP ALARM	1.00
LIGHT	DOME LIGHT W/ REAR MOUNT SWITCH	2.00
GRAB HANDLE	CURBSIDECHROME GRAB HANDLE	1.00
GRAB HANDLE	ROADSIDECHROME GRAB HANDLE	1.00
MUD FLAP	24 INCH X 36 INCH SMYRNA CARGO MUD FLAP -WEIGHT TICKET & CERTIFICATION -DELIVERY TO GRANDE FORD	1.00

Sales subtotal amount	Total discount	Total charges	Net amount	Sales tax	Round-off	Total
14,655.00	0.00	250.00	14,905.00	0.00	0.00	14,905.00 USD

<b>REQ DATE</b>
<b>04/13/2021</b>

<b>REQUISITION NUMBER</b>
<b>0000099221</b>

PRINTED 04/13/2021

VENDOR KEY : LONGHORN003  
 SHIP DATE : 04/13/2021  
 FISCAL YEAR : 2020-2021  
 ENTERED BY : TERRYDAW000  
 ORIGINAL REQ # : 0000099221

**VENDOR:**  
 LONGHORN BUS SALES  
 9100 N LOOP EAST  
 HOUSTON, TX 77029

**SHIP TO:**  
 AUXILIARY CENTER  
 601 E AVENUE E  
 MIDLOTHIAN, TX 76065

PHONE: (713) 631-9306

ATTN: DAWN TERRY

QUANTITY	UNIT	DESCRIPTION OF ITEMS OR MATERIALS	UNIT PRICE	AMOUNT
3	EACH	Buyboard 630-20 IC Corp Model C2608 2021 54 Passenger Bus	99979.00000	299,937.00
1	EACH	Buyboard Fee Contract 630-20	800.00000	800.00
<b>ACCOUNT SUMMARY (FOR INTERNAL USE)</b>				
		<b>ACCOUNT NUMBER</b>	<b>ACCOUNT AMOUNT</b>	
		199 E 34 6631 00 999 0 23 999	300,737.00	
<b>CommCode:</b> Auto/ Bus Vehicle Purchase				
			<b>PAGE TOTAL</b>	300,737.00
			<b>TOTAL</b>	300,737.00

This is a Requisition and not an official Purchase Order.  
 The District is not financially responsible for the  
 unauthorized purchases made with a Requisition.



# LONGHORN BUS SALES

9100 N Loop East  
Houston, TX 77029  
(713) 631-9306

## Midlothian I.S.D.

Date: April 12, 2021

Body Manufacturer: IC Corp Model: C2608 2021

Chassis Manufacturer: IC Corp Model: PB 105 2021

Capacity: 54 Passenger - 3 w/c positions

Price/Unit: **\$99,979.00** Number of units: **3** Total: **\$299,937.00**

<u>Standard Body Specifications</u>	<u>Chassis Specifications</u>
78" headroom standard Fire resistant seating (16) Intermittent windshield wipers and washers Seat centers on 27" spacing Upgrade first aid kit and body fluid clean-up kit Full insulation - roof & sides Complete body undercoating Fire extinguisher Rubber flooring throughout (black) Triangle reflectors (3) Aluminum aisle strips 90,000 BTU front heater/defrost system School bus yellow paint Two full rows interior dome lights Rear view mirror inside (6 x 30) Rosco cross over mirror Rear view mirrors (2) "Roscoe" Fan drivers defog Emergency door buzzer and hold-back device State spec LED light pkg. Three-step riser National hi-back air ride driver's seat Drivers three-point seatbelt Two roof hatches (Transpec) Four emergency E/E windows, vertical hinge Reflectorized air stop arm (Speciality) Monitor, post trip inspection Light, exterior, check	Engine: Cummins ISB 6.7 Horsepower: 220 Torque: 520 ft-lb Wheelbase: 218" Alternator: 325 amp high output Transmission: Allison 2500 w/7yr warranty Brakes: Full AIR Front axle: 10,000# Rear axle: 19,800# Tires: 255/70R 22.5H Hankook Fuel tank: 65 gallon BTR Power steering Tilt steering Tachometer Warning buzzers Auto. slack adjusters Moisture ejectors Air ride suspension Battery system 3-12 volt 1950 CCA Power source 12V Mud flaps OTA Cummins Engine Exhaust Brake Idle system

<u>Body Options Included</u>	<u>Chassis Options Included</u>
Entrance air door outward opening Reflective material Vandalock security system Interior paint (spring white) 3pt Seat belts 16 sets 5/8" Marine plywood over steel floor Dark tinted/laminated safety glass 80,000 BTU right wall heater White roof Upholstery, Prevaill, (gray) 4 LH Track mounted seats, 2 RH track seats 3 w/c positions "Sure-Lok" retractable (Titan) Lift - w/c model "Braun" NCL1000FIB3451 AM/FM/MPLX/PA radio system Strobe Light Collision Mitigation Bendix Advanced Wingman PDI DOT inspection Lettering (MIDLOTHIAN I.S.D.) Govern speed set at 65mph Weigh bus Air conditioning 126K BTU (2 bulkheads and drivers dash) (ProAir) Safety Vision 4 camera system	Cruise control Hour meter gauge pkg. Daytime running lights Hand throttle Warranty - towing: 24/unlimited \$550 max

Estimated delivery time: 45-60 days

F.O.B: Midlothian I.S.D.

Prices are good 60 days from date of this proposal.

**Buy Board fee not included. If purchasing through Buy Board, and additional \$800.00 must be applied to purchase order (fee is per purchase order not per bus). Longhorn Buy Board number 630-20.**

Both body and chassis specifications meet or exceed Texas School Bus Specification # 070-SB-16 for 2018.

**Authorized Signature** \_\_\_\_\_

All stock buses are subject to prior sale.

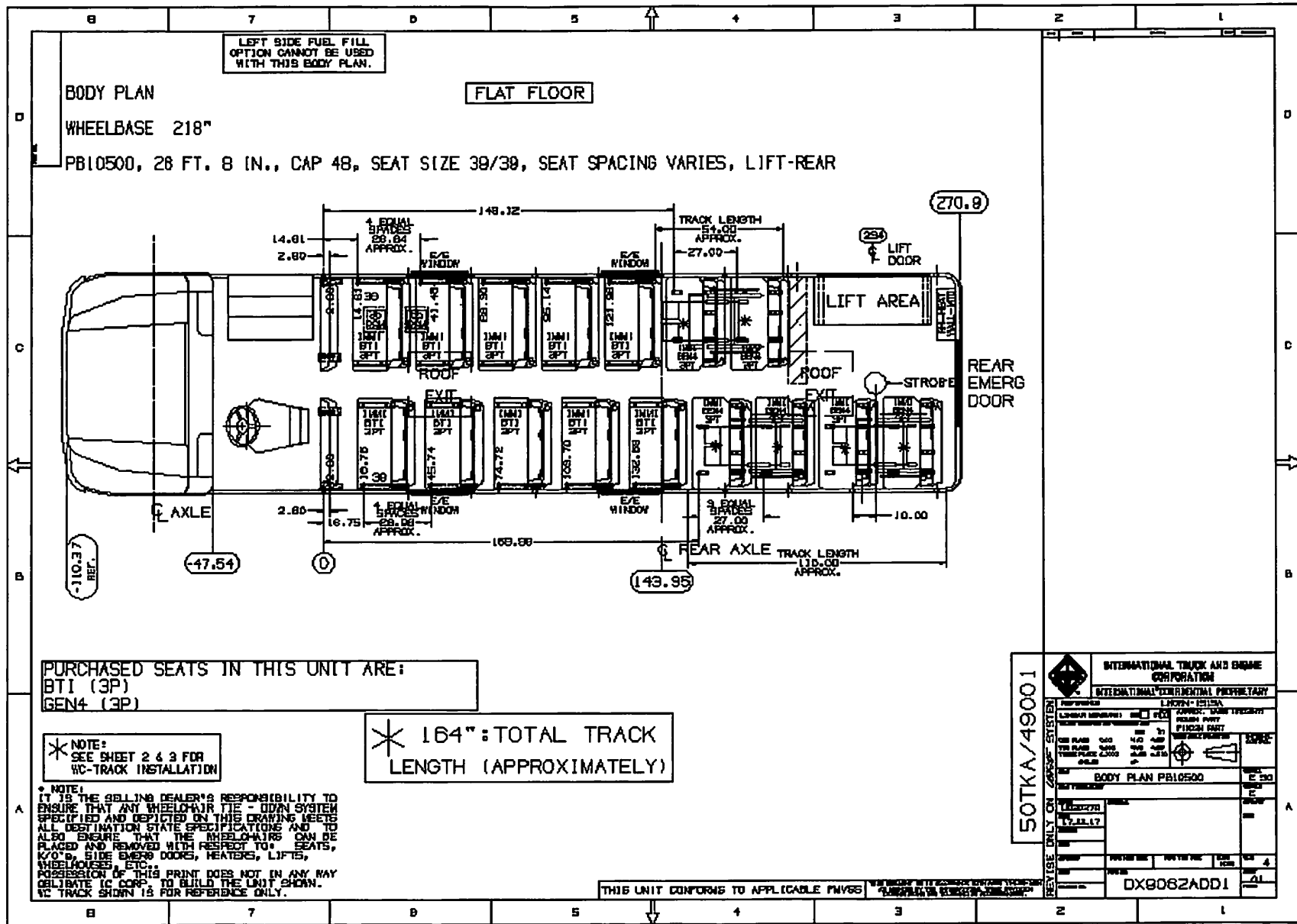

**Midlothian I.S.D. School Board Agenda Item Detail**  
**L.A. Mills Administrative Complex Boardroom**

<b>Board Meeting Date:</b>	<b>April 19, 2021</b>	
<b>Item:</b>	<b>2020-2021 Budget Amendment</b>	
<b>Supporting Document(s):</b>	Electronic: Yes <input checked="" type="checkbox"/> No <input type="checkbox"/>	Hard Copy: Yes <input type="checkbox"/> No <input checked="" type="checkbox"/>
<b>Background Information:</b>	<p>The following amendments have been presented to the Board for consideration for April 2021:</p> <p style="text-align: center;"><b><u>General Fund</u></b></p> <ul style="list-style-type: none"> <li>• Transfer \$2,400 from Staff Development to Extra/Co-Curricular for video and audio recording for all secondary schools for virtual submission due to COVID for Curriculum.</li> <li>• Transfer \$100 from Staff Development to Extra/Co-Curricular for Math Pentathlon awards for Curriculum.</li> <li>• Transfer \$78,000 from General Administration (\$45,000), Security (\$29,000) and Transportation (\$4,000) to Extra/Co-Curricular for the purchase of an additional box truck for use by our high school bands, future warehouse and athletics. Currently renting one every week during football season.</li> <li>• Transfer \$47,000 from Health Services (\$9,000), Instructional Administration (\$6,000), Media Services (\$10,000), Instruction (\$22,000) to Extra/Co-Curricular for the purchase of a dually truck for the Ag department. The oldest in the fleet is aging and at this time should not be driven on long distance trips with students. It will be retained and used locally between campuses and the Ag Barn.</li> <li>• Revise budget to reduce lost revenue and unused expenses relating to COVID.</li> </ul>	
<b>Fiscal Impact/Budget Function Code:</b>	None	
<b>Policy:</b>	<b>CE (Legal), CE (Local)</b>	
<b>District Goal:</b>	Facilitate budget process and building designs through allocated district resources that foster flexible and innovative learning spaces.	
<b>Administration Recommended Option:</b>	It is the Administration’s recommendation that the amendments be approved.	
<b>Motion:</b>	Presented as a consent item. If the item is pulled from the consent agenda, the motion might be: “I make a motion to approve the budget amendments to the 2020-2021 budget as presented.”	
<b>Presenter:</b>	Jim Norris	

Adopted/Amended Budgets for Funds 170, 180, and 199 (Library, Athletics, & General Fund)

	<u>% OF BUDGET</u>	<u>ORIGINAL BUDGET TOTALS</u>	<u>PREVIOUS AMENDMENTS</u>	<u>THIS AMENDMENT</u>	<u>AMENDED BUDGET TOTALS</u>	<u>% OF BUDGET</u>
<b>Revenues</b>						
57 Local	55.94%	\$53,871,878	\$546,072	(\$146,900) [5]	\$54,271,050	54.27%
58 State	42.94%	\$41,346,541	\$3,065,204	\$0	\$44,411,745	44.41%
59 Federal	1.12%	\$1,079,500	\$239,652	\$0	\$1,319,152	1.32%
Total Revs FY20-21	100.00%	<u>\$96,297,919</u>	<u>\$3,850,928</u>	<u>(\$146,900)</u>	<u>\$100,001,947</u>	100.00%
<b>Expenditures</b>						
<b>FUNCTION</b>						
11 Instruction	53.20%	\$51,243,690	\$1,497,079	(\$135,870) [4] [5]	\$52,604,899	51.53%
12 Media Services	1.14%	\$1,093,568	\$93,478	(\$10,000) [4]	\$1,177,046	1.15%
13 Staff Development	1.41%	\$1,353,623	\$125,217	(\$2,500) [1] [2]	\$1,476,340	1.45%
21 Instructional Administration	1.21%	\$1,161,926	(\$93,135)	(\$6,000) [4]	\$1,062,791	1.04%
23 School Leadership	4.96%	\$4,775,969	\$328,011	\$0	\$5,103,980	5.00%
31 Counseling Services	3.35%	\$3,229,121	\$141,816	\$0	\$3,370,937	3.30%
32 Social Work Services	0.00%	\$0	\$0	\$0	\$0	0.00%
33 Health Services	1.15%	\$1,109,929	\$77,584	(\$18,800) [4] [5]	\$1,168,713	1.14%
34 Transportation	2.58%	\$2,479,708	\$455,117	(\$4,000) [3]	\$2,930,825	2.87%
35 Child Nutrition	0.00%	\$0	\$3,044	\$0	\$3,044	0.00%
36 Extra/Co-Curricular Activities	4.51%	\$4,341,072	(\$93,920)	\$127,500 [1] [2] [3] [4]	\$4,374,652	4.29%
41 Central Administration	3.83%	\$3,690,131	\$157,694	(\$45,000) [3]	\$3,802,825	3.73%
51 Maintenance	9.69%	\$9,333,748	\$201,641	(\$23,230) [5]	\$9,512,159	9.32%
52 Security	1.47%	\$1,414,324	\$53,974	(\$29,000) [3]	\$1,439,298	1.41%
53 Data Processing	2.06%	\$1,981,436	(\$8,287)	\$0	\$1,973,149	1.93%
61 Community Services	0.01%	\$8,500	\$28,570	\$0	\$37,070	0.04%
71 Debt Service	0.24%	\$228,602	(\$55,882)	\$0	\$172,720	0.17%
81 Facilities	0.00%	\$0	\$0	\$0	\$0	0.00%
95 JJAEP	0.06%	\$60,000	(\$60,000)	\$0	\$0	0.00%
97 Payments to Tax Increment Fund	8.52%	\$8,200,572	\$3,079,133	\$0	\$11,279,705	11.05%
99 Tax Costs	0.61%	\$592,000	\$0	\$0	\$592,000	0.58%
Total Exps FY20-21	100.00%	<u>\$96,297,919</u>	<u>\$5,931,134</u>	<u>(\$146,900)</u>	<u>\$102,082,153</u>	100.00%
Budgeted Increase / (Decrease) to Fund Balance		<u>\$0</u>	<u>(\$2,080,206)</u>	<u>\$0</u>	<u>(\$2,080,206)</u>	

[1] Transfer \$2,400 from Staff Development to Extra/Co-Curricular for video and audio recording for all secondary schools for virtual submissions due to COVID.

[2] Transfer \$100 from Staff Development to Extra/Co-Curricular for Math Pentathlon awards for Curriculum.

[3] Transfer \$78,000 from General Administration (\$45,000), Security (\$29,000) and Transportation (\$4,000) to Extra/Co-Curricular for the purchase of an additional box truck for use by our high school bands, future warehouse and athletics. Currently renting one every week during football/marching season.

[4] Transfer \$47,000 from Health Services (\$9,000), Instructional Administration (\$6,000), Media Services (\$10,000), Instruction (\$22,000) to Extra/Co-Curricular for the purchase of a dually truck for the Ag department. The oldest in the fleet is aging and at this time should not be driven on long distance trips with students. It will be retained and used locally between campuses and the Ag Barn.

[5] Revise budget to reduce lost revenue and unused expenses relating to COVID.

**Midlothian I.S.D. School Board  
Agenda Item Detail  
L.A. Mills Administrative Complex Boardroom**

<b>Board Meeting Date:</b>	<b>April 14, 2021</b>		
<b>Item:</b>	<b>Consider Donations and Gifts to the District</b>		
<b>Supporting Document(s):</b>	<b>Electronic: Yes <input type="checkbox"/> No <input checked="" type="checkbox"/></b>	<b>Hard Copy: Yes <input type="checkbox"/> No <input checked="" type="checkbox"/></b>	
<b>Background Information:</b>	According to CDC (LOCAL), “The Board may accept any bequest or gift of money or property on behalf of the District. The gift shall become the sole property of the District for its use and disposition. All gifts shall be given to the District and not to a particular school. At the discretion of the superintendent or designee, the gift may be used in a particular school.”		
<b>Fiscal Impact/Budget Function Code:</b>	Heritage Baseball	\$500 monetary donation	H Squared field Services
	Heritage Baseball	\$85 monetary donation	Danielle Chavez
	McClatchey Elem	\$6,000 monetary donation for playground equipment	Gerald and Deborah Zolman (Grandparents to 3 DME children)
	Heritage Wrestling	American Wrestlers Co. donated 30 singlets valued at \$60/each (\$1,800 total) to Heritage Wrestling	America Wrestlers Co.
	Mt. Peak Elementary	\$5,000 monetary donation for field day shirts	Methodist Mansfield
	Running Total for 2020/2021		\$91,589.96
	April, 2021		\$13,385
	March, 2021		1,650.61
	February, 2021		33,693.49
	January, 2021		-0-
	December		300.00
	November		\$7,360.86
	October		\$5,800
	September		\$ 7,500
August		\$21,900	
July		\$0	
<b>Policy:</b>	CDC (LOCAL)		
<b>District Goal:</b>	Facilitate budget process and building designs through allocated district resources that foster flexible and innovative learning space		
<b>Administration Recommended Option:</b>	Accept the donations		
<b>Suggested Motion</b>	This is a consent item. If the item is pulled a motion might be: “I make a motion to approve the donation(s) to the District as presented.”		
<b>Presenter:</b>	Courtney Carpenter, Ed.D.		

**Midlothian I.S.D. School Board Agenda Item Detail**  
**L.A. Mills Administrative Complex Boardroom**

<b>Board Meeting Date:</b>	<b>April 19, 2021</b>	
<b>Item:</b>	<b>Consider Contract Recommendations for 2021-2022</b>	
<b>Supporting Document(s):</b>	Electronic: Yes <input checked="" type="checkbox"/> No <input type="checkbox"/>	Hard Copy: Yes <input type="checkbox"/> No <input checked="" type="checkbox"/>
<b>Background Information:</b>	<p>Our standard operating procedure over the past several years has been to place this item in the Consent Agenda.</p> <p>Each year staff (administrators, teachers, nurses, counselors, and librarians) are evaluated by supervising staff and contract renewal recommendations are then submitted for Board consideration. The recommendations follow on the attached spreadsheet.</p>	
<b>Fiscal Impact/Budget Function Code:</b>		
<b>Policy:</b>	NA	
<b>District Goal:</b>	Develop a comprehensive staffing plan to foster innovation, effective communication and a high performing culture throughout the district.	
<b>Administration Recommended Option:</b>	It is the recommendation of the administration that the 2021-2022 staff contracts be approved as submitted.	
<b>Motion:</b>	A motion to that effect might be, "I move to accept the 2021-2022 staff contract recommendations as presented."	
<b>Presenter:</b>	Courtney Carpenter	

**.Midlothian I.S.D. School Board Agenda Item Detail**  
**L.A. Mills Administrative Complex Boardroom**

<b>Board Meeting Date:</b>	<b>April 19, 2021</b>	
<b>Item:</b>	<b>Instructional Materials Allotment TEKS Certification Form 2021-22</b>	
<b>Supporting Document(s):</b>	Electronic: Yes <input checked="" type="checkbox"/> No <input type="checkbox"/>	Hard Copy: Yes <input type="checkbox"/> No <input checked="" type="checkbox"/>
<b>Background Information:</b>	<p>Districts are required to certify annually (to the State Board of Education and the Commissioner) that, for each subject in the required curriculum, students have access to the instructional materials that cover all of the Texas Essential Knowledge and Skills.</p> <p>Midlothian ISD students do have access to instructional materials that cover all of the Texas Essential Knowledge and Skills.</p>	
<b>Fiscal Impact/Budget Function Code:</b>	N/A	
<b>Policy:</b>	N/A	
<b>District Goal:</b>	Design innovative learning environments while increasing academic rigor through aligned teaching and learning.	
<b>Administration Recommended Option:</b>	The Administration’s recommendation is to certify and accept the form as presented.	
<b>Motion:</b>	This is a consent agenda item. If pulled for discussion a motion might be, “I move to accept and certify the 2021-22 Instructional Materials Allotment TEKS Certification Form.”	
<b>Presenter:</b>	Shelle Blaylock	

---

NOTE: This template is for planning purposes only, and will not be submitted to the Texas Education Agency. Please submit your responses using this form:

<https://app.smartsheet.com/b/form/bf5755712b724621a1ae5c78c80e2f4c>

First and Last Name: Shelle Blaylock  
 E-mail: [shelle.blaylock@misd.gs](mailto:shelle.blaylock@misd.gs)  
 District Name: Midlothian ISD  
 County District Number: 70908

Certification of Math Instructional Materials				
	Product(s) you plan to use for Tier 1 instruction to cover 100% of standards in school year 2021-22. List all that apply.	What is your district's approach to covering 100% of the standards for math?	What implementation approach does your district take for math materials?	Notes
Grades K-5 Grades 6-8 Grades 9-12	enVisionMATH Texas 2.0 (Savvas Learning Company LLC formerly Pearson K12 Learning), Texas Edition (Savvas Learning Company LLC formerly Pearson K12 Learning), Texas Algebra 1 (School Education Group, a division of The McGraw-Hill Companies,	Adopt TEKS Resource System (TRS) and align purchased materials to TRS scope and sequence	All school leaders required to implement district's approach	

Certification of RLA Instructional Materials				
	Product(s) you plan to use for Tier 1 instruction to cover 100% of standards in school year 2021-22. List all that apply.	What is your district's approach to covering 100% of the standards for RLA?	What implementation approach does your district take for RLA materials?	Notes
Grades K-2 Grades 3-5 Grades 6-8 Grades 9-12	Wonders (McGraw-Hill School Division(Contract Vendor)) TEKS Resource System (TRS) StudySync (McGraw-Hill School Division(Contract Vendor)) HMH Into Literature Texas	Adopt TEKS Resource System (TRS) and align purchased materials to TRS scope and sequence	All school leaders required to implement district's approach	

Certification of Science Instructional Materials				
	Product(s) you plan to use for Tier 1 instruction to cover 100% of standards in school year 2021-22. List all that apply.	What is your district's approach to covering 100% of the standards for science?	What implementation approach does your district take for science materials?	Notes
Grades K-5 Grades 6-8 Grade 9-12	STEMscopes 2.0 (Accelerate Learning Inc.) Texas Interactive Science (Savvas Learning Company LLC formerly Pearson K12 Learning) HMH Texas Biology	Adopt TEKS Resource System (TRS) and align purchased materials to TRS scope and sequence	All school leaders required to implement district's approach	

Certification of Social Studies Instructional Materials				
	Product(s) you plan to use for Tier 1 instruction to cover 100% of standards in school year 2021-22. List all that apply.	What is your district's approach to covering 100% of the standards for social studies?	What implementation approach does your district take for social studies materials?	Notes
Grades K-5 Grades 6-8 Grades 9-12	Texas Studies Weekly (Studies Weekly, Inc.) TX World Cul & Geo (School Education Group, a division of The McGraw-Hill Companies) HMH World History Texas (Houghton Mifflin Harcourt Depository)	Adopt TEKS Resource System (TRS) and align purchased materials to TRS scope and sequence	All school leaders required to implement district's approach	

**Midlothian I.S.D. School Board Agenda Item Detail**  
**L.A. Mills Administrative Complex Boardroom**

<b>Board Meeting Date:</b>	<b>April 19, 2021</b>	
<b>Item:</b>	<b>Consider Approval for Summer Work Schedule</b>	
<b>Supporting Document(s):</b>	<b>Electronic: Yes <input checked="" type="checkbox"/> No <input type="checkbox"/></b>	<b>Hard Copy: Yes <input type="checkbox"/> No <input checked="" type="checkbox"/></b>
<b>Background Information:</b>	<p>Midlothian ISD believes that offering a compressed work week opportunities during the summer may help employees balance work, personal and family responsibilities.</p> <p>Summer work schedule:</p> <ul style="list-style-type: none"> <li>● Monday, May 31 through Friday, July 30.</li> <li>● 4 - day work week Monday - Thursday from 7:30 - 4:45</li> <li>● 1 day taken off during this time period = 1.25 days</li> </ul> <p>The district will return to its regular hours of operation on Monday, Aug. 2, 2021.</p>	
<b>Fiscal Impact/Budget Function Code:</b>	NA	
<b>Policy:</b>	NA	
<b>District Goal:</b>	Build a strong foundation of the MISD culture through communication and engagement to empower all stakeholders.	
<b>Administration Recommended Option:</b>	The administration recommends the board approve the recommendation as presented.	
<b>Motion:</b>	A motion might be, "I move to approve the compressed summer work schedule as presented."	
<b>Presenter:</b>	Courtney Carpenter/KayLynn Day	

**Midlothian I.S.D. School Board Agenda Item Detail**  
**L.A. Mills Administrative Complex Boardroom**

<b>Board Meeting Date:</b>	April 19, 2021	
<b>Item:</b>	Student Dress Code for 2021-22 School Year	
<b>Supporting Document(s):</b>	Electronic: Yes <input checked="" type="checkbox"/> No <input type="checkbox"/>	Hard Copy: Yes <input type="checkbox"/> No <input checked="" type="checkbox"/>
<b>Background Information:</b>	<p>Campus behavior coordinators have met with campus student leadership councils to discuss modifications to the student dress code for the 2021-2022 school year. Student and campus administration input was shared and discussed with Dr. Hemmle</p> <p>After careful consideration of all the information, the administration recommends no modifications to the Student Dress Code for 2021-2022 school year.</p>	
<b>Fiscal Impact/Budget Function Code:</b>	None	
<b>Policy:</b>	FNCA (LEGAL)	
<b>District Goal:</b>	Provide a safe and secure learning environment that supports the social and emotional well-being of our school community.	
<b>Administration Recommended Option:</b>	The administration proposes <b>no modifications</b> for the 2021-2022 Student Dress Code.	
<b>Motion:</b>	This is being presented as a consent agenda item; if pulled for discussion a motion might be, "I move to approve the student dress code for 2021/2022 as presented."	
<b>Presenter:</b>	Dr. Al Hemmle/KayLynn Day	

**Midlothian I.S.D. School Board Agenda Item Detail**  
**L.A. Mills Administrative Complex Boardroom**

<b>Board Meeting Date:</b>	<b>April 19, 2021</b>	
<b>Item:</b>	<b>Asynchronous Testing Day Waiver</b>	
<b>Supporting Document(s):</b>	Electronic: Yes <input checked="" type="checkbox"/> No <input type="checkbox"/>	Hard Copy: Yes <input type="checkbox"/> No <input checked="" type="checkbox"/>
<b>Background Information:</b>	<p>The Texas Education Agency has released a waiver to help schools maintain COVID social distancing during state testing.</p> <p>This waiver may be submitted prior to or after the testing day and asynchronous instruction.</p>	
<b>Fiscal Impact/Budget Function Code:</b>	N/A	
<b>Policy:</b>	N/A	
<b>District Goal:</b>	N/A	
<b>Administration Recommended Option:</b>	District administration recommends approving the Hybrid Instruction During District-Scheduled testing Days for the grades(s) and dates outlined in the motion.	
<b>Motion:</b>	<p>This is presented as a consent agenda; however, if pulled a motion may be, <i>"I move to approve District Administration submitting the waiver for Hybrid Instruction during District-Schedule testing days for 8th grade students on May 11th; 12th grade students on March 3, April 6 and 8, May 4 and May 6th; and 11th grade students on May 5th."</i></p>	
<b>Presenter:</b>	Shorr Heathcote/Shelle Blaylock	

**Midlothian I.S.D. School Board Agenda Item Detail**  
**L.A. Mills Administrative Complex Boardroom**

<b>Board Meeting Date:</b>	April 19, 2021	
<b>Item:</b>	Consideration of General Contractor and Overall Budget for CSP 2021-012 Multiple Campus Roofing Projects	
<b>Supporting Document(s):</b>	Electronic: Yes <input checked="" type="checkbox"/> No <input type="checkbox"/>	Hard Copy: Yes <input type="checkbox"/> No <input checked="" type="checkbox"/>
<b>Background Information:</b>	<p>According to Education Code Section 44.031, all school district contracts for the purchase of goods and services, except contracts for the purchase of produce or vehicle fuel, valued at \$50,000 or more in the aggregate for a 12-month period shall be made by the method of the following methods that provides the best value for the district:</p> <ol style="list-style-type: none"> <li>(1) Competitive bidding for services other than construction services;</li> <li>(2) Competitive sealed proposals for services other than construction services;</li> <li>(3) A request for proposals, for services other than construction services;</li> <li>(4) An interlocal contract</li> <li>(5) A method provided by Chapter 2267, Government code, for construction services;</li> <li>(6) The reverse auction procedure as defined by Section 2155.062(d), Government Code; or</li> <li>(7) The formation of a political subdivision corporation under Section 304.001, Local Government Code.</li> </ol> <p>The solicitation for Competitive Sealed Proposals for the multiple campus roofing projects was posted on March 11 and March 19, 2021 in the newspaper, on the MISD website and various plan rooms. There was a total of 10 roofing contractors that requested the plans.</p> <p>The proposals were due and opened at 10:00 am, April 01, 2021. Eight roofing contractors submitted proposals as well as a proposal for a scope specific trade. A summary of the proposals including all alternates and line items is attached to this template.</p> <p>As part of the CSP selection criteria, the proposals were reviewed and scored based on cost, reputation, quality, experience, warranty work, project closeout and project team. A couple of the low cost proposals were verified to be incorrect and were withdrawn. It is the recommendation of the MISD staff to propose the following roofing contractors for the following campuses:</p> <p style="margin-left: 40px;"><u>Flynn BEC LP</u></p> <ul style="list-style-type: none"> <li>- The MILE</li> <li>- Baxter Elementary</li> <li>- Frank Seale Middle School</li> </ul> <p style="margin-left: 40px;"><u>Progressive Roofing</u></p> <ul style="list-style-type: none"> <li>- DAEP</li> <li>- LA Mills</li> <li>- Randall Hill Support Center</li> </ul>	

	Attached is the overall budget identifying all necessary costs with this project of \$6,176,863.60 and the CSP evaluation spreadsheet.
<b>Fiscal Impact/Budget Function Code:</b>	Project to be funded from the 2016 Bond
<b>Policy:</b>	CH (Local)
<b>District Goal:</b>	Facilitate budget process and building designs through allocated district resources that foster flexible and innovative learning spaces.  Provide a safe and secure learning environment that supports the social and emotional well-being of our school community.
<b>Administration Recommended Option:</b>	It is the recommendation of the Administration that the Board approve staff to enter into contract with Flynn BEC LP and Progressive Roofing and approve the overall project budget of \$6,176,863.60 for the Multiple Campus Roofing Projects.
<b>Motion:</b>	This is being present as a consent agenda; if pulled, a motion might be: "I move to approve staff to enter into contract with Flynn BEC LP and Progressive Roofing and approve the overall project budget of \$6,176,863.60 for the Multiple Campus Roofing Projects".
<b>Presenter:</b>	Rola Fadel

Midlothian ISD CSP 2021-012 Multiple Camps Roofing - Plan Holders				
Company	Name	Email	Phone	Website
VLK Architects	Helen Yan	<a href="mailto:hyan@vlkarchitects.com">hyan@vlkarchitects.com</a>	972.265.6110	<a href="http://www.vlkarchitects.com">www.vlkarchitects.com</a>
Bond Proe store	Travis Chapman	<a href="mailto:travis@bondprorestore.com">travis@bondprorestore.com</a>	682.414.7751	<a href="https://www.fbmc.com">https://www.fbmc.com</a> , <a href="https://bondprorestore.com">https://bondprorestore.com</a>
Virtual Builders Exchange, LLC	Heidi Shaffer	<a href="mailto:north@virtualbx.com">north@virtualbx.com</a>	(210) 564-6900	<a href="https://www.virtualbx.com/">https://www.virtualbx.com/</a>
Prime Vendor Inc.	Kim Jones	<a href="mailto:primevendor123@gmail.com">primevendor123@gmail.com</a>	910.805.9630	<a href="http://www.prime-vendor.com/">http://www.prime-vendor.com/</a>
JJ Red Commercial roofing, LLC	Robert Edwards	<a href="mailto:redwards@jjredroofing.com">redwards@jjredroofing.com</a>	214.394.0930	<a href="https://www.jjredroofing.com/">https://www.jjredroofing.com/</a>
<b>ANDERSEN COMMERCIAL BUSINESS UNIT</b>	Tony Madline	<a href="mailto:Tony.Madline@andersencorp.com">Tony.Madline@andersencorp.com</a>	651.301.2240	<a href="http://AndersenWindows.com">Andersen Windows &amp; Doors   LOVE THE LIFE YOU SEE.™</a>
Dodge	Michelle Van Vleet	<a href="mailto:michelle.vanvleet@construction.com">michelle.vanvleet@construction.com</a>	562.923.5436	<a href="https://www.construction.com/">https://www.construction.com/</a>
Advantage USAA Inc.	Emma Ortiz	<a href="mailto:advantage2000@advantageusaa.com">advantage2000@advantageusaa.com</a>	830-885-2950	<a href="http://AdvantageUSAA.com">Advantage USAA, Inc</a>
Construction connect	Logan Hinton	<a href="mailto:Logan.Hinton@constructconnect.com">Logan.Hinton@constructconnect.com</a>	513-458-8615	
Midlo Contracting	Derrick Steele	<a href="mailto:derrick@midlocontracting.com">derrick@midlocontracting.com</a>	214-949-3212	<a href="https://www.midlocontracting.com/">https://www.midlocontracting.com/</a>
Flynn BEC LP	<b>Shelbie McDiffett</b>	<a href="mailto:Shelbie.McDiffett@flynncompanies.com">Shelbie.McDiffett@flynncompanies.com</a>	<b>1.817.662.6411</b>	<a href="https://flynncompanies.com/">https://flynncompanies.com/</a>
Tri Lam Roofing	Anthony Dominguez	<a href="mailto:trilamanthony@gmail.com">trilamanthony@gmail.com</a>	817-253-9905	<a href="http://tri-lamroofing.com/Home_Page.html">http://tri-lamroofing.com/Home_Page.html</a>
CCX Construction	Timothy M. Brock	<a href="mailto:tim@ccxcon.com">tim@ccxcon.com</a>	214-280-3438	
Innovative Construction SVC LLC	Levi Hall	<a href="mailto:Levi@innovativesvc.com">Levi@innovativesvc.com</a>	469-612-5380	<a href="http://www.innovativesvc.com">www.innovativesvc.com</a>

## Multiple Campus Roofing Projects

Midlothian Independent School District

Proposal Date: April 1, 2021

	JJ RED	FLYNN	PARAGON	RMS	PROGRESSIVE	RUBY	CASTRO	CS ADVANTAGE
<i>Proposal Security (5%)</i>	Y	Y	Y	Y	Y	Y	Y	Y
<i>Contractor Qualification Statement (AIA A305)</i>	Y	Y	Y	Y	Y	Y	Y	Y
<i>Addendum 1</i>	Y	Y	Y	Y	Y	Y	Y	Y
<i>Addendum 2</i>	Y	Y	Y	Y	Y	Y	Y	Y
<i>Addendum 3</i>	Y	Y	Y	Y	Y	Y	Y	Y
<i>Addendum 4</i>	Y	Y	Y	N	Y	Y	N	Y
<b>THE MILE Base Proposal</b>	\$ 1,264,586.00	\$ 1,035,600.00	\$ 1,159,000.00	-	\$ 1,152,196.00	\$ 803,600.00	\$ 870,154.00	\$ 845,000.00
<b>DAEP Base Proposal</b>	-	\$ 84,100.00	\$ 98,000.00	-	\$ 66,909.00	\$ 61,490.00	\$ 80,920.00	\$ 50,000.00
<b>LA MILLS Base Proposal</b>	\$ 664,822.00	\$ 753,625.00	\$ 807,000.00	\$ 1,498,780.00	\$ 602,284.00	\$ 1,228,620.00	\$ 317,317.00	\$ 689,000.00
<b>BAXTER Base Proposal</b>	-	\$ 1,397,419.00	\$ 1,536,100.00	\$ 1,425,863.00	\$ 1,528,031.00	\$ 1,228,620.00	\$ 1,274,167.00	\$ 1,190,000.00
<b>RANDALL HILL Base Proposal</b>	\$ 460,965.00	\$ 505,000.00	\$ 482,900.00	\$ 573,900.00	\$ 380,230.00	\$ 335,960.00	\$ 222,904.00	\$ 498,000.00
<b>FRANK SEALE Base Proposal</b>	-	\$ 1,894,534.00	\$ 1,933,100.00	-	\$ 2,244,135.00	\$ 1,547,710.00	\$ 1,394,828.00	\$ 1,550,000.00
<b>TOTAL PROPOSAL</b>	\$ 2,390,373.00	\$ 5,670,278.00	\$ 6,016,100.00	\$ 3,498,543.00	\$ 5,973,785.00	\$ 5,206,000.00	\$ 4,160,290.00	\$ 4,822,000.00

# Multiple Campus Roofing Projects Budget Spreadsheet

2016 BOND BUDGET - \$6,351,061.50

## Construction Costs

### *Flynn BEC LP*

The MILE Base Proposal	\$1,035,600.00
Baxter Elementary Base Proposal	\$1,397,419.00
Frank Seale Middle School Base Proposal	\$1,894,534.00

### *Progressive Roofing*

DAEP Base Proposal	\$66,909.00
LA Mills Base Proposal	\$602,284.00
Randall Hill Base Proposal	\$380,230.00

---

<b>Total Construction Costs</b>	<b>\$5,376,976.00</b>
---------------------------------	-----------------------

## Unit Prices

Rigid Insulation - 1 1/2" thick rigid insulation for replacement of existing damaged insulation, as specified including all labor and materials	Extra	Credit
<i>Flynn BEC LP</i>	\$1.25	\$1.25
<i>Progressive Roofing</i>	\$3.50	\$3.50

## Owner's Construction Contingency

- 5% Contingency	\$268,848.80
<b>Total Owner's Construction Contingency</b>	<b>\$268,848.80</b>

## Architect's Fees - 5% of Construction Costs

- Construction Documents	
- Bidding & Negotiation	
- Construction Administration	
<b>Total Basic Services</b>	<b>\$268,848.80</b>

## Architect's Reimbursables

- Reproductions	\$1,000.00
<b>Total Consultant Fees</b>	<b>\$1,000.00</b>

## Owner Related Soft Costs

- Test and Balance (EAB)	\$256,190.00
- Document Hyperlinking (BlueLynk)	\$5,000.00
<b>Total Owner Related Soft Costs</b>	<b>\$261,190.00</b>

---

<b>TOTAL OVERALL PROJECT BUDGET</b>	<b>\$6,176,863.60</b>
-------------------------------------	-----------------------

**2021-012 Multi Campus Roofing Projects**

Vendors	Vendor	Proposal Form	Pricing Document	Felony Conviction	Debarment	Non Discrim	Non Collusion	1295	CIQ	Terrorist/Boycott	
	Flynn Companies	✓	✓	✓	✓	✓	✓	✓	✓	✓	
	Paragon	✓	✓	✓	✓	✓	✓	✓	✓	✓	
	RMS	x	✓	✓	✓	✓	✓	✓	✓	✓	
	Progressive	✓	✓	✓	✓	✓	✓	✓	✓	✓	
	Castro	x	✓	✓	✓	✓	✓	✓	✓	✓	
	JJ Red	✓	✓	✓	✓	✓	✓	✓	✓	✓	
	Ruby	x	✓	✓	✓	✓	✓	✓	✓	✓	
	CS Advantage	✓	✓	✓	✓	✓	✓	✓	✓	✓	
		<b>COST</b>	<b>REPUTATION</b>	<b>QUALITY</b>	<b>EXPERIENCE</b>	<b>WARRANTY</b>	<b>PROJECT CLOSEOUT</b>	<b>PROJECT TEAM</b>		<b>TOTAL</b>	
		<b>30</b>	<b>10</b>	<b>10</b>	<b>15</b>	<b>10</b>	<b>10</b>				
Flynn Companies	22.5	10	10	15	10	10	15			92.5	
Paragon	21.1	10	10	15	0	0	0			56.1	
RMS	18.2	8	10	15	0	0	15			66.2	
Progressive	23.9	10	10	15	8	8	15			89.9	
Castro											
JJ Red	22.7	5	10	15	10	10	15			87.7	
Ruby	26.4	5	5	5	0	0	0			41.4	
CS Advantage	27.5	8	10	15	0	0	5			65.5	

**Midlothian I.S.D. School Board Agenda Item Detail**  
**L.A. Mills Administrative Complex Boardroom**

<b>Board Meeting Date:</b>	<b>April 19, 2021</b>	
<b>Item:</b>	<b>Consideration of General Contractor and Overall Budget for New Elementary No. 08</b>	
<b>Supporting Document(s):</b>	<b>Electronic: Yes <input checked="" type="checkbox"/> No <input type="checkbox"/></b>	<b>Hard Copy: Yes <input type="checkbox"/> No <input checked="" type="checkbox"/></b>
<b>Background Information:</b>	<p>According to Education Code Section 44.031, all school district contracts for the purchase of goods and services, except contracts for the purchase of produce or vehicle fuel, valued at \$50,000 or more in the aggregate for a 12-month period shall be made by the method of the following methods that provides the best value for the district:</p> <ol style="list-style-type: none"> <li>(1) Competitive bidding for services other than construction services;</li> <li>(2) Competitive sealed proposals for services other than construction services;</li> <li>(3) A request for proposals, for services other than construction services;</li> <li>(4) An interlocal contract</li> <li>(5) A method provided by Chapter 2267, Government code, for construction services;</li> <li>(6) The reverse auction procedure as defined by Section 2155.062(d), Government Code; or</li> <li>(7) The formation of a political subdivision corporation under Section 304.001, Local Government Code.</li> </ol> <p>The solicitation for Competitive Sealed Proposals for Elementary No. 08 was posted on March 11 and March 19, 2021 in the newspaper, on the MISD website and various plan rooms. There was a total of 13 general contractors that requested the plans.</p> <p>The base proposal plus three alternates was due and opened at 2:00 pm, March 25, 2021. Twelve general contractors submitted proposals as well as a proposal for a scope specific trade. This resulted in the following totals (in alphabetical order):</p> <p style="text-align: center;"><u>Base proposals – not including Alternates</u></p> <ul style="list-style-type: none"> <li>– Adolfson &amp; Peterson - \$26,271,700.00</li> <li>– Big Sky Construction - \$27,592,000.00</li> <li>– Cadence McShane Construction - \$25,597,853.00</li> <li>– Construction Zone - \$24,447,407.00</li> <li>– ICI Construction - \$25,909,000.00</li> <li>– Imperial Construction - \$25,204,000.00</li> <li>– Key Construction - \$24,826,061.00</li> <li>– Phillips May - \$27,090,333.00</li> <li>– Ratcliff Constructors - \$25,087,109.00</li> <li>– Reeder General Contractors - \$25,530,000.00</li> <li>– RJM - \$28,118,000.00</li> </ul>	

	<ul style="list-style-type: none"> <li>- Satterfield Pontikes Construction - \$25,629,500.00</li> </ul> <p><u>Scope Specific Contractor</u></p> <ul style="list-style-type: none"> <li>- EAB (Test &amp; Balance) - \$87,630.00</li> </ul> <p>A summary of the proposals including all alternates and line items is attached to this template.</p> <p>As part of the CSP selection criteria, contractors were required to submit a list of their proposed subcontractors by 4:00 March 29, 2021 and the Contractor interviews were to take place on April 01, 2021. This information would help with the section process. The contractors selected for interviews were based on the lowest cost submitted. MISD staff, along with VLK staff interviewed the following four general contractors:</p> <ul style="list-style-type: none"> <li>- Construction Zone</li> <li>- Key Construction</li> <li>- Ratcliff Constructors</li> <li>- Imperial Construction</li> </ul> <p>Interviews were a great benefit and provided better insight on the contractors proposed staff, experience with similar projects and discussions on market conditions and challenges. This process enabled us to select one contractor to enter into the next phase of negotiations. On Tuesday April 06, 2021 MISD staff entered into negotiations with Imperial Construction and reviewed the scope, proposed subcontractors and a list of optional value engineering items. These items do not affect the look and feel of the building that has been presented.</p> <p>After thorough review, MISD staff recommends Imperial Construction as the General Contractor for the New Elementary No. 08 with the following alternates:</p> <ul style="list-style-type: none"> <li>- Alternate No. 01 – Additional Parking Lot \$235,000.00</li> <li>- Alternate No. 02 – Decorative Metal Fencing (14<sup>th</sup> St.) \$75,000.00</li> </ul> <p>Attached is the overall budget identifying all necessary costs with this project of \$29,591,903.36 and the CSP evaluation spreadsheet.</p>
<b>Fiscal Impact/Budget Function Code:</b>	Project to be funded from the 2016 Bond
<b>Policy:</b>	CH (Local)
<b>District Goal:</b>	<p>Facilitate budget process and building designs through allocated district resources that foster flexible and innovative learning spaces.</p> <p>Provide a safe and secure learning environment that supports the social and emotional well-being of our school community.</p>
<b>Administration Recommended Option:</b>	It is the recommendation of the Administration that the Board approve staff to enter into contract with Imperial Construction and approve the overall budget of \$29,591,903.36 for the New Elementary No. 08 project.

<b>Motion:</b>	This is being presented by a consent agenda; if pulled, a motion might be: “I move to approve staff to enter into contract with Imperial Construction and approve the overall budget of \$29,591,903.36 for the New Elementary No. 08”.
<b>Presenter:</b>	Rola Fadel

Proposal Scoring																											
Weighted Percentage				Adolfson & Peterson Construction		Big Sky Construction		Cadence McShane Construction		Construction Zone		ICI Construction, Inc.		Imperial Construction		Key Construction		Phillips May		Ratcliff Constructors, LP		Reeder General Contractors, Inc.		RJM Contractors, Inc.		Satterfield & Pontikes Construction, Inc.	
Criteria	Basis	Factor	Weighted Score	Rank	Score	Rank	Score	Rank	Score	Rank	Score	Rank	Score	Rank	Score	Rank	Score	Rank	Score	Rank	Score	Rank	Score	Rank	Score		
Fee Proposal				9	23.38	11	22.28	5	24.03	1	25.00	8	23.68	4	24.34	2	24.71	10	22.56	3	24.44	6	24.02	12	21.84	7	23.98

Qualitative Scoring																											
Weighted Percentage				Adolfson & Peterson Construction		Big Sky Construction		Cadence McShane Construction		Construction Zone		ICI Construction, Inc.		Imperial Construction		Key Construction		Phillips May		Ratcliff Constructors, LP		Reeder General Contractors, Inc.		RJM Contractors, Inc.		Satterfield & Pontikes Construction, Inc.	
Criteria	Basis	Factor	Weighted Score	Points	Score	Points	Score	Points	Score	Points	Score	Points	Score	Points	Score	Points	Score	Points	Score	Points	Score	Points	Score	Points	Score		
Reputation	30	0.33	10	0.00	0.00	0.00	0.00	28.00	9.33	29.00	9.67	0.00	0.00	29.00	9.67	26.00	8.67	0.00	0.00	28.00	9.33	29.00	9.67	0.00	0.00	0.00	0.00
Quality	30	0.33	10	10.00	3.33	8.00	2.67	23.67	7.89	28.00	9.33	8.00	2.67	22.00	7.33	10.00	3.33	10.00	3.33	26.00	8.67	23.00	7.67	6.00	2.00	10.00	3.33
Experience	30	0.50	15	27.00	13.50	20.00	10.00	24.00	12.00	20.00	10.00	23.00	11.50	34.00	17.00	25.00	12.50	20.00	10.00	27.00	13.50	25.00	12.50	14.00	7.00	29.00	14.50
Warranty Work	10	1.00	10	0.00	0.00	0.00	0.00	9.33	9.33	10.00	10.00	0.00	0.00	7.50	7.50	10.00	10.00	0.00	0.00	9.33	9.33	9.33	9.33	0.00	0.00	0.00	0.00
Project Closeout	10	1.00	10	0.00	0.00	0.00	0.00	6.00	6.00	6.00	6.00	0.00	0.00	6.00	6.00	0.00	0.00	0.00	0.00	6.00	6.00	6.00	6.00	0.00	0.00	0.00	0.00
Project Team	26	0.58	15	22.00	12.69	22.00	12.69	6.00	3.46	21.00	12.12	22.00	12.69	23.00	13.27	17.00	9.81	26.00	15.00	24.00	13.85	21.00	12.12	14.00	8.08	21.00	12.12
Schedule and Phasing	8	0.63	5	5.00	3.13	5.00	3.13	19.00	11.88	4.00	2.50	5.00	3.13	5.00	3.13	3.00	1.88	3.00	1.88	4.00	2.50	4.00	2.50	3.00	1.88	5.00	3.13
Subtotal			75		32.65		28.48		59.89		59.62		29.98		63.89		46.18		30.21		63.18		59.78		18.95		33.07

Composite Scoring																									
				56.03	50.76	83.92	84.62	53.67	88.24	70.89	52.77	87.62	83.80	40.79	57.05										

Final Ranking				Adolfson & Peterson Construction		Big Sky Construction		Cadence McShane Construction		Construction Zone		ICI Construction, Inc.		Imperial Construction		Key Construction		Phillips May		Ratcliff Constructors, LP		Reeder General Contractors, Inc.		RJM Contractors, Inc.		Satterfield & Pontikes Construction, Inc.	
				8	11	4	3	9	1	6	10	2	5	12	7												

**Midlothian ISD Elementary School #8 - Value Options**

Item	Description	Savings	Accepted Y or N	Notes
1a	Alternate bullet resistant glazing film in lieu of specified.	\$151,380	Y	15 mil in lieu of specified. Cannot be accepted with 1b.
1b	Armorguard glazing in lieu of bullet resistant film.	\$171,145		Cannot be accepted with 1a.
2	Hydromulch in lieu of sod.	\$39,514	Y	VLK/MISD - Please confirm extent of mulch ILO sod.
3	Modernfold folding glass partition in lieu of Nana-Wall	\$389,588	Y	
4	Reduced canopy at Area C Kitchen	\$9,450	Y	Reduced to approximately 6'x12'
5a	Reduced canopy at Area B/C North elevation	\$23,500	Y	Reduced to approximately 21'1"x22'2" & 73'6"x11'8"
5b	Reduced sidewalk at Area B/C Canopy to match potential reduction at canopy.	\$11,886	Y	
6	Alternate to metal linear ceiling product.	\$0		No Cost Savings
7	Tectum panels in lieu of acoustical fiberglass ceiling panels at Gym.	\$0		No Cost Savings
8	Alternate masonry materials	\$33,250	Y	Acme brick and blackston stone.
9	Alternate metal wall panel	\$0		No Cost Savings
10	PSI wall paneling in lieu of wood wall paneling	\$0		No Cost Savings at this time
11a	2.3 insulation at mod bit roof in lieu of 2.5 insulation	\$0		Vendor to have pricing by close of business 4/13
11b	Standard finish ply at top coat in lieu of specified.	\$0		Vendor to have pricing by close of business 4/13
12	Reduced sidewalks	\$23,175	Y	
13	Aluminum feeders in lieu of copper	\$37,750	Y	From transformer to MSA; evaluating additional possible savings from MSA to DPs.
14	Alternate lighting fixture package	\$0		Lighting vendor to have pricing by close of business 4/13
15	Modifications to HVAC equipment package	\$0		Equipment vendor to have pricing by close of business 4/13
16	Reduce acoustic panel thickness	\$6,000	Y	
17	Omit concrete encased dutct bank for electrical secondary.	\$7,500		
18	Alternate metal wall panel attachment system in lieu of specified.	\$0		No Cost savings at this time
19	Reduce Owner Contingency to 2.5%	\$573,000	Y	Original Contingency: \$1,123,000; New:\$550,000
20	Alternate LVT product	\$39,513	Y	Tarkett LVT ILO Tandus
21	Painted gypsum board in lieu of solid surface backsplash at cubbies.	\$15,940	Y	
22	Sheathing and air barrier in lieu of combo system.	\$0		No savings at this time
23a	Standard metal deck at clearstory roofs in lieu of dovetail acoustical deck.	\$26,000	Y	Cannot be accepted with 23b or 23c.
23b	Standard Versa deck at clearstory roofs in lieu of dovetail acoustical deck	\$2,000		Cannot be accepted with 23a or 23c.
23c	Dovetail metal deck (no acoustic value) in lieu of dovetail acoustical deck.	\$3,000		Cannot be accepted with 23a or 23b.
24	Custom kitchen equipment package	\$34,000	Y	
25a	Reduced height of ceramic wall tile at non-wet wall locations in restrooms to 5' AFF.	\$16,985	Y	Cannot be accepted with 25b.
25b	Painted gypsum board in lieu of ceramic wall tile at non-wet wall locations in restrooms.	\$44,493		Cannot be accepted with 25a.
26	65 Gallon trees in lieu of 95 gallon as specified.	\$15,184		
27		\$0		
28		\$0		
<b>Total Saving</b>		<b>\$1,430,931</b>		

### Midlothian Elementary School No. 8

Midlothian Independent School District  
 Proposal Date: May 25, 2021

	Adolfson & Peterson Construction	Big Sky Construction	Cadence McShane Construction	Construction Zone	ICI Construction, Inc.	Imperial Construction	Key Construction	Phillips May	Ratcliff Constructors, LP	Reeder General Contractors, Inc.	RJM	Satterfield & Pontikes Construction, Inc.
<b>BASE PROPOSAL</b>	\$ 26,135,000.00	\$ 27,450,000.00	\$ 25,475,000.00	\$ 24,350,000.00	\$ 25,750,000.00	\$ 25,049,000.00	\$ 24,699,000.00	\$ 26,940,333.00	\$ 24,992,000.00	\$ 25,375,000.00	\$ 27,930,000.00	\$ 25,499,000.00
<b>Line Item: Builders Risk Insurance</b>	\$ 21,700.00	\$ 35,000.00	\$ 50,384.00	\$ 28,000.00	\$ 38,000.00	\$ 47,000.00	\$ 15,061.00	\$ 20,000.00	\$ 20,109.00	\$ 35,000.00	\$ 60,000.00	\$ 19,500.00
<b>Line Item: Centralized Battery System</b>	\$ 115,000.00	\$ 107,000.00	\$ 72,469.00	\$ 69,407.00	\$ 121,000.00	\$ 108,000.00	\$ 112,000.00	\$ 130,000.00	\$ 75,000.00	\$ 120,000.00	\$ 128,000.00	\$ 111,000.00
<b>BASE PROPOSAL + LINE ITEMS</b>	\$ 26,271,700.00	\$ 27,592,000.00	\$ 25,597,853.00	\$ 24,447,407.00	\$ 25,909,000.00	\$ 25,204,000.00	\$ 24,826,061.00	\$ 27,090,333.00	\$ 25,087,109.00	\$ 25,530,000.00	\$ 28,118,000.00	\$ 25,629,500.00
<b>Alternate 1</b> - For providing an additional parking lot and gates on the south side of the site	\$ 215,000.00	\$ 222,000.00	\$ 187,712.00	\$ 231,000.00	\$ 244,000.00	\$ 235,000.00	\$ 242,000.00	\$ 250,000.00	\$ 182,000.00	\$ 250,000.00	\$ 192,000.00	\$ 178,000.00
<b>Alternate 2</b> - For providing decorative metal fencing in lieu of vinyl-clad chain link fencing per area and details on drawings and specifications	\$ 81,000.00	\$ 65,000.00	\$ 62,304.00	\$ 165,000.00	\$ 70,000.00	\$ 75,000.00	\$ 68,000.00	\$ 192,000.00	\$ 140,000.00	\$ 75,000.00	\$ 127,600.00	\$ 94,000.00
<b>Alternate 3</b> - For providing an irrigation booster pump	\$ 38,000.00	\$ 27,000.00	\$ 33,408.00	\$ 347,000.00	\$ 37,000.00	\$ 45,000.00	\$ 44,000.00	\$ 30,000.00	\$ 30,807.00	\$ 45,000.00	\$ 42,000.00	\$ 23,000.00
<b>BASE + LINE ITEMS + ALTERNATES</b>	\$ 26,567,700.00	\$ 27,879,000.00	\$ 25,847,869.00	\$ 24,843,407.00	\$ 26,223,000.00	\$ 25,514,000.00	\$ 25,136,061.00	\$ 27,532,333.00	\$ 25,409,109.00	\$ 25,855,000.00	\$ 28,437,600.00	\$ 25,901,500.00

## 2021-013 New Elementary No. 08 Budget Spreadsheet

2016 BOND BUDGET - \$30,000,000.00

### Construction Costs

GC - Imperial Construction	
- Base Bid	\$25,049,000.00
- Builders Risk	\$47,000.00
- Centralized Battery System	\$108,000.00
- Alternate No. 01 - Additional Parking Lot	\$235,000.00
- Alternate No. 02 - Decorative Metal Fencing on 14th St.	\$75,000.00
- Alternate No. 03 - Irrigation Booster Pump	\$45,000.00
- Value Engineering - See attached list	\$1,430,931.00
<b>Total Construction Costs</b>	<b>\$24,083,069.00</b>

### Architect's Fees - 6% of Construction Costs

Architectural Services	
Structural - LAFP	
MEP - RWB	
Civil - TNP	
Landscape - TNP	
Total Basic Services	\$1,444,984.14

### Architect's Add Services

Food Service	\$19,950.00
Security & Technology - EMA	\$28,000.00
Third Party Peer Review - Isbell	\$14,250.00
Total Additional Services - Add 5%	\$62,200.05

### Architect's Reimbursables

- Reproductions	\$5,000.00
- ADA Review	\$5,000.00
Total Reimbursables	\$10,000.00

**Total Consultant Fees** **\$1,517,184.19**

**Owner Related Soft Costs**

- Plan Review	\$53,468.19
- Civil Review	\$2,000.00
- Site Review	\$1,000.00
- Building Permit	\$82,258.75
- Plat	\$1,500.00
- Topo Survey	\$36,000.00
- Geo- Tech Analysis	\$17,790.00
- Material Testing	\$174,377.80
- Off site costs - Road & Water line	\$775,000.00
- Test and Balance (EAB)	\$87,630.00
- Marquee	\$35,000.00
- Job Sign	\$634.00
- Document Hyperlinking (BlueLynk)	\$17,644.00
<b>Total Owner Related Soft Costs</b>	<b>\$1,284,302.74</b>

**FF&E**

- Fixtures & Furniture	\$1,200,000.00
- Technology	\$1,000,000.00
<b>Total FF&amp;E Allocated Costs</b>	<b>\$2,200,000.00</b>

**MISD Contingency**

- 2% Contingency	\$507,347.43
<b>Total MISD Contingency</b>	<b>\$507,347.43</b>

**TOTAL OVERALL PROJECT BUDGET** **\$29,591,903.36**



**Midlothian I.S.D. School Board Agenda Item Detail**  
**L.A. Mills Administrative Complex Boardroom**

<b>Board Meeting Date:</b>	<b>April 19, 2021</b>	
<b>Item:</b>	<b>Consider for Approval RFP 2021-018 Heritage Furniture Phase II</b>	
<b>Supporting Document(s):</b>	<b>Electronic: Yes    No</b>	<b>Hard Copy: Yes    No</b>
<b>Background Information:</b>	<p>According to Education Code Section 44.031, all school district contracts for the purchase of goods and services, except contracts for the purchase of produce or vehicle fuel, valued at \$50,000 or more in the aggregate for a 12-month period shall be made by the method of the following methods that provides the best value for the district:</p> <ol style="list-style-type: none"> <li>(1) Competitive bidding for services other than construction services;</li> <li>(2) Competitive sealed proposals for services other than construction services;</li> <li>(3) A request for proposals, for services other than construction services;</li> <li>(4) An interlocal contract</li> <li>(5) A method provided by Chapter 2267, Government code, for construction services;</li> <li>(6) The reverse auction procedure as defined by Section 2155.062(d), Government Code; or</li> <li>(7) The formation of a political subdivision corporation under Section 304.001, Local Government Code.</li> </ol> <p>Furniture products were bid through a request for proposal. The RFP notice was advertised in the Midlothian Mirror March 11, 2021 and March 18, 2021, and emails were sent to current and prospective vendors. The RFP was posted to the school district website on March 11, 2021. The proposals were opened on March 30, 2021, and evaluated through committee review. Administration is seeking approval from the Board of Trustees.</p> <p>We received nine bids from the following vendors: Business Interiors, HCONE, Lone Star Furnishings, McKinney Office Supply, Meteor Education, Oak Cliff Office Supplies, School Specialty, Texas Furniture Source and Weaver Manufacturing.</p> <p>Business Interiors, McKinney Office Supply and School Specialty provided pricing on all the desired pieces requested. HCONE, Lone Star Furnishings, and Meteor Education provided pricing on all items but with many alternates. OCOP, Texas Furniture Source and Weaver Manufacturing only bid a partial listing of the desired items, with Weaver bidding all alternates. Business Interiors and McKinney Office Supply provided the best pricing, a point of contact for all project needs and freight/installation for the majority of the products that meet the needs of the construction timeframe and the existing</p>	

	<p>campus furniture. Meteor Education provided substantially lower cost on the desired stools. The other vendors did not meet the complete desired needs of the district.</p> <p>In order to create a cohesive feel between the existing classrooms and the new classrooms, the current furniture will be distributed throughout the building and each classroom (new and old) will receive several new pieces to provide improved flexibility and personalization of seating choices. The proposed vendors will allow for this vision and will provide the customer service and quality expected.</p>
--	--

	The results with Administration’s recommendation are attached.
<b>Fiscal Impact/Budget Function Code:</b>	2016 Bond Construction Funds
<b>Policy:</b>	CH (local)
<b>District Goal:</b>	Facilitate budget process and building designs through allocated district resources that foster flexible and innovative learning spaces.
<b>Administration Recommended Option:</b>	It is the recommendation of the administration that the Board accept the proposals from Business Interiors, McKinney Office Supply and Meteor Education for furniture selections indicated. Business Interiors and Meteor Education provided a bid for classroom and collaborative areas that best match the vision for Heritage High School. Additionally, McKinney Office Supply provided the best pricing for the administrative office area furniture.
<b>Motion:</b>	Presented as a consent Item: If the item is pulled from the consent agenda, the motion might be: “I make a motion to award the Heritage High School furniture contracts to Business Interiors at a maximum cost of \$636,628.98, McKinney Office Supply at a maximum of \$71,123.54, and Meteor Education at a maximum of \$113,275.80 for a total overall amount of \$821,028.32”
<b>Presenter:</b>	Krista Tipton/Jim Norris

<b>KEY:</b>
Lowest bid on desired product
Alternate spec & bid
Recommended vendor

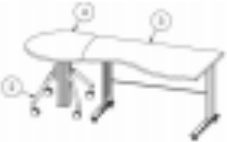
					Bid (Business)	
ITEM		DESCRIPTION	MFR*	PROD #	Non-Specified Alternate	UNIT PRICE
1		HIERARCHY 5-STAR STOOL WITH ARMS BLACK PLASTIC BASE SOFT CASTERS 22" - 33" COLOR: WILSONART CUSTOM REGIMENTAL RED SHELL	MOORECO INC	53512-XXXX-WA-SC		\$ 177.00
2		REFLECTION WORKSTATION 30"D X 60"L TOP 36"W X 23"D CASEBODY 36" HEIGHT SHELF AND 2 DOUBLE DOORS LOCK CONNECTING MAGNETS FOR HANGOUT STOOLS (2 LOCATIONS) UNASSEMBLED BULK PACKAGING. 236 LBS COLOR: WILSONART CUSTOM REGIMENTAL RED TOP WITH BLACK BEVELED ARMOR EDGE BLACK HPL CASEBODY WITH BLACK EDGE BANDING	WB MANUFACTURING	CLW7254-630036-2MAAC/C		\$ 1,125.82
3		13" SQUARE SEAT, 24" FIXED SILVER HANGOUT STOOL BP (10 LBS.) COLOR: SILVER	WB MANUFACTURING	HS24		\$ 61.77
4		TEACHER DESK COLOR: SPECIFY LAM- CONCRETE GROOVZ SPECIFY EDGE- GRAPHITE SPECIFY BASE- BLACK	RIGHTANGLE PRODUCTS	RCMBC245436 NGABC242724 WS1306036Z0168 WS5E263626Z0053		\$ 1,308.14
ITEM		DESCRIPTION	MFR*	PROD #	Non-Specified Alternate	UNIT PRICE

<b>KEY:</b>
Lowest bid on desired product
Alternate spec & bid
Recommended vendor

						<b>Bid (</b>
						<b>Business</b>
5		NSL FURNITURE PRODUCT TIDE FLIP TABLE 30" X 66" TIDE W/TUBULAR TBASE 29" FIXED HEIGHT HANDLE RELEASE AND INSERTS CASTERS UNASSEMBLED BULK PACKAGING. CLASS 70. 80 LBS. COLORS: DOVE GREY HPL TOP WITH BLACK BEVELED ARMOR EDGE. BLACK LEGS.	WB MANUFACTURING	GIB7A22304997- CH7722		\$ 651.80

<u>ITEM</u>		<u>DESCRIPTION</u>	<u>MFR*</u>	<u>PROD #</u>	<u>Non-Specified Alternate</u>	<u>UNIT PRICE</u>
6		IGNITION WK MID-BCK PNEU SWIVEL TILT BACK: HEIGHT ADJ ARM: HEIGHT AND WIDTH ADJ CASTER: SOFT BACK: MESH BACK FABRIC: GRADE: III UPHOLSTERY FABRIC SELECTION: MOXIE COLOR: CARBON BASALT BASETYPE: STANDARD BASE COLOR: CARBON/BASALT PAINT: FRAME: BLACK	HON	HIWM1.A.S.M.SX23 .T.SB		\$ 353.32

<u>ITEM</u>		<u>DESCRIPTION</u>	<u>MFR*</u>	<u>PROD #</u>	<u>Non-Specified Alternate</u>	<u>UNIT PRICE</u>
7		POWER TOWER  COLOR: PLATINUM	MOORECO INC	27735		\$ 257.46

<u>ITEM</u>		<u>DESCRIPTION</u>	<u>MFR*</u>	<u>PROD #</u>	<u>Non-Specified Alternate</u>	<u>UNIT PRICE</u>

<b>KEY:</b>
Lowest bid on desired product
Alternate spec & bid
Recommended vendor

				Bid (	
				Business	
8		<p>NSL FURNITURE PRODUCT ELEVATE 24" X 28.5" PLYMOUTH STUDENT DESK ADJUSTABLE HEIGHT PNEUMATIC BASE DUAL WHEEL SOFT TREAD LOCKING CASTERS &amp; GRAND HANK GLIDES 27.94"-42.94" OVERALL ADJUSTABLE HEIGHT 1 BACKPACK HOOK UNASSEMBLED PACKAGING - BULK, 55 LBS.</p> <p>COLORS: TOP - WILSONART MYSTIQUE NIGHT 4760-60 BLACK BEVELED LOTZ ARMOR EDGE BLACK FRAME FINISH</p>	WB MANUFACTURING	PNH7365-ADJ-BPH	\$ 369.45

ITEM		DESCRIPTION	MFR*	PROD #	Non-Specified Alternate	UNIT PRICE
9		<p>HIGH RISE/SILVERADO ROUND OTTOMAN 18" X 18" CASTERS WRAP</p> <p>COLORS: WRAP AROUND OTTOMAN - ARC COM HIGH RISE PRIMARY #1 TOP - ARC COM SILVERADO 2 STEEL #41</p>	FOMCORE LLC	F005-18X18-C		\$ 331.30

ITEM		DESCRIPTION	MFR*	PROD #	Non-Specified Alternate	UNIT PRICE
10		<p>REPLAY® MOBILE OPEN BOOK NOOK BASE CABINET WITH 1" ADJUSTABLE SHELF 36" WIDTH, 16" DEPTH, 36" HEIGHT, FINISHED BOTH ENDS FULLY ASSEMBLED (CASTERS INSTALLED ONSITE BY OTHERS). BULK PACKAGING. 109 LBS.</p> <p>COLORS: TOP - WILSONART CUSTOM REGIMENTAL RED WITH BLACK EDGE BANDING CASEBODY - BLACK HPL WITH BLACK EDGE BANDING.</p>	WB MANUFACTURING	LRS1140-AC		\$ 569.19

<b>KEY:</b>
Lowest bid on desired product
Alternate spec & bid
Recommended vendor

ITEM	DESCRIPTION	MFR*	PROD #	Business	
				Non-Specified Alternate	UNIT PRICE
11	 <p>QUOTE FOR SPECIAL CABINET CD1000 CUSTOM MOBILE CABINET WITH SHELF 48"W X 36"H X 18"D CASTERS FULLY ASSEMBLED (CASTERS INSTALLED ONSITE BY OTHERS) BULK PACKAGING. 113 LBS. COLORS: TOP - WILSONART CUSTOM REGIMENTAL RED WITH BLACK EDGE BANDING CASEBODY - BLACK HPL WITH BLACK EDGE BANDING.</p>	WB MANUFACTURING	SP304366-1/C (MODIFIED)		\$ 617.18

ITEM	DESCRIPTION	MFR*	PROD #	Business	
				Non-Specified Alternate	UNIT PRICE
12	 <p>SEED ROCKER FRAME- 18" COLOR: WILSONART CUSTOM REGIMENTAL RED SHELL PLATINUM FRAME</p>	MOORECO INC	SG.SD.R.18.6XX.7 XX.PL		\$ 103.00

ITEM	DESCRIPTION	MFR*	PROD #	Business	
				Non-Specified Alternate	UNIT PRICE
13	 <p>C-TABLE 27" FIXED HEIGHT 18" WORKSURFACE 73P EDGE COLOR: LAM - PRESSED LINEN 4991-38 EDGE - BLUE GREY BASE - BLACK</p>	KRUEGER INTERNATIONAL	CTABLE-73P		\$ 250.50

ITEM	DESCRIPTION	MFR*	PROD #	Non-Specified Alternate	UNIT PRICE
------	-------------	------	--------	-------------------------	------------

<b>KEY:</b>
Lowest bid on desired product
Alternate spec & bid
Recommended vendor

					Bid (
					Business
14		C-TABLE MAX 29" FIXED HEIGHT ROUND WITH CURVE TOP 24" WORKSURFACE 73P EDGE COLOR: LAM - PRESSED LINEN 4991-38 EDGE - BLUE GREY BASE - BLACK	KRUEGER INTERNATIONAL	CMDAP24-73P	\$ 267.00

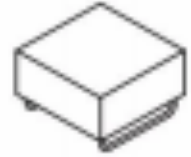
ITEM		DESCRIPTION	MFR*	PROD #	Non-Specified Alternate	UNIT PRICE
15		HUB LAMINATE TABLE 26" X 26" GANGING-WITH (2) GANGERS ASSEMBLIES SHIPPED PER UNIT BLACK NYSON GLIDES COLOR: BASE FINISH - BLACK TOP LAM - PRESSED LINEN 4991-38 SIDE LAM - PRESSED LINEN 4991-38 BLACK POWER MODULE	KRUEGER INTERNATIONAL	H24T		\$ 796.50

ITEM		DESCRIPTION	MFR*	PROD #	Non-Specified Alternate	UNIT PRICE
16		HUB ARMLESS LOUNGE, CONTRAST, 26" X 78" GANGING- WITH GANGERS (2) GANGING ASSEMBLIES SHIPPED PER UNIT NO PRIVACY SCREEN NO MOISTURE BARRIER BLACK NYLON GLIDES COLOR: BACK FABRIC- ARC COM SPINNAKER CHILI PEPPER #863027 SEAT/SIDE FABRIC- ARC COM EMPRESS SMOKE #23AC61882 BASE AND SEAT BACK UPRIGHT FINISH- BLACK	KRUEGER INTERNATIONAL	H43/FC		\$ 1,841.19

ITEM		DESCRIPTION	MFR*	PROD #	Non-Specified Alternate	UNIT PRICE
------	--	-------------	------	--------	-------------------------	------------



<b>KEY:</b>
Lowest bid on desired product
Alternate spec & bid
Recommended vendor

					<b>Bid (Business)</b>	
17		IGNITION TASK STOOL PNEU ADJ FOOTREST BACK: HEIGHT ADJ ARM: HEIGHT AND WIDTH ADJ CASTER: SOFT BACK: MESH BACK FABRIC: GRADE: III UPHOLSTERY FABRIC SELECTION: MOXIE--BASALT PAINT: FRAME: BLACK BASETYPE: BASE: STANDARD BASE COLOR: MOXIE - BASALT PAINT: FRAME: BLACK	HON	HITS5.A.S.M.SX23 .T.SB	\$	376.16

<b>ITEM</b>		<b>DESCRIPTION</b>	<b>MFR*</b>	<b>PROD #</b>	<b>Non-Specified Alternate</b>	<b>UNIT PRICE</b>
18		LYRA LOUNGE CHAIR UPH BACK SLED BASE CONTRAST 29"W X 29"D NO MOISTURE BARRIER BLACK NYLON GLIDES BLACK BASE FINISH COLOR: OUTER SHELL – ARC COM SPINNAKER CHILI PEPPER #863027 BACK CUSHION – ARC COM EMPRESS SMOKE #23AC61882 SEAT CUSHION – ARC COM EMPRESS SMOKE #23AC61882 INNER ARM CUSHION – ARC COM SPINNAKER CHILI PEPPER #863027	KRUEGER INTERNATIONAL	1423US/FC		\$ 1,436.31

<b>ITEM</b>		<b>DESCRIPTION</b>	<b>MFR*</b>	<b>PROD #</b>	<b>Non-Specified Alternate</b>	<b>UNIT PRICE</b>
19		HIGH RISE/SILVERADO ROUND OTTOMAN 18" X 18" CASTERS WRAP COLOR: DESIGNTEX WEND HEAT	FOMCORE LLC	F005-18X18-C		\$ 297.02

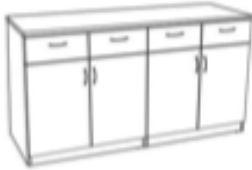
<b>KEY:</b>
Lowest bid on desired product
Alternate spec & bid
Recommended vendor

					Bid (Business	
ITEM	DESCRIPTION	MFR*	PROD #	Non-Specified Alternate	UNIT PRICE	
20	 <p>HYPERWORK 144" X 48" BOAT SHAPED CONFERENCE TABLE CUSTOMER 42" HEIGHT OPTIONAL BOX BASES ADD (4) COVE POWER UNITS- EACH WITH 2 POWER/2USB CENTERED AND EQUALLY SPACED COLOR: POWER COVE - SILVER LAMINATE- SHORELINE</p>	HIGH POINT FURNITURE INDUSTRIES	HW_BT14448B/QT1032		\$ 3,096.81	
21	 <p>BUFFET CREDENZA 4 DRAWER TWO STORAGE COMPARTMENTS WITH ONE ADJUSTABLE SHELF EACH BEHIND FOUR DOORS 36" BUFFET HEIGHT 63.5" X 24" X 36" COLOR: SPECIFY LAM - SHORELINE SPECIFY PULLS- TBAR NICKLE</p>	HIGH POINT FURNITURE INDUSTRIES	H__4D4SBC		\$ 1,246.57	
22	 <p>CULINARY TABLE 60W X 30D X 35H **MODIFIED TO HAVE EM-9A CENTER TABLE BRACING KIT** **BAR IS NOT ALONG THE BACK, IT IS BEING MOVED/MODIFIED TO THE CENTER***</p>	DIVERSIFIED WOODCRAFTS	XS-6030-OB-MOD		\$ 527.22	
23	 <p>WORK TABLE CASTER KIT, SET OF 4</p>	DIVERSIFIED WOODCRAFTS	250516		\$ 56.41	

<b>KEY:</b>
Lowest bid on desired product
Alternate spec & bid
Recommended vendor

ITEM	DESCRIPTION	MFR*	PROD #	Business	
				Non-Specified Alternate	UNIT PRICE
24	 <p>NPS® 18"-25" HEIGHT ADJUSTABLE DESIGNER STOOL</p> <p>COLOR: PERSIAN BLUE/BLACK</p>	NATIONAL PUBLIC SEATING	6825-10		\$ 95.00

ITEM	DESCRIPTION	MFR*	PROD #	Business	
				Non-Specified Alternate	UNIT PRICE
25	 <p>NUCLEUSGUEST MULTI-PURPOSE CHAIR FOUR LEG STACKING FRAME ARM: FIXED ARM ALL SURFACE CASTER BACK: STRETCH BLACK FABRIC GRADE: III UPHOLSTERY FABRIC ELECTION: MOXIE--BASALT FRAME: BLACK COLOR: MOXIE -BASALT PAINT: FRAME: BLACK</p>	HON	HN6.F.A.IM.SX23.T		\$ 256.13



ITEM	DESCRIPTION	MFR*	PROD #	Business	
				Non-Specified Alternate	UNIT PRICE
26	 <p>10500 SERIES 60W X 30D X 29-1/2H DBL PED DSK 3/2 RECT TOP LAMINATE: GRD L1 STANDARD LAMINATES COLOR: SHAKER CHERRY</p>	HON	H105892.FF		\$ 658.36

ITEM	DESCRIPTION	MFR*	PROD #	Non-Specified Alternate	UNIT PRICE
------	-------------	------	--------	-------------------------	------------

<b>KEY:</b>
Lowest bid on desired product
Alternate spec & bid
Recommended vendor

					<b>Bid (</b>	
					<b>Business</b>	
27		PRESIDE 20W X 72D X 36H HOSPITALITY CREDENZA LAMTOP: GR L1 STANDARD LAMINATES EDGE: SHAKER LAMCHASSIS: GR L1 STANDARD LAMINATES PULL: LOOP SATIN NICKEL CUTOUT: NO CUTOUT COLOR: SHAKER CHERRY	HON	HTLCRED72.F.F.F.J.N	\$	1,185.72

<b>KEY:</b>
Lowest bid on desired product
Alternate spec & bid
Recommended vendor

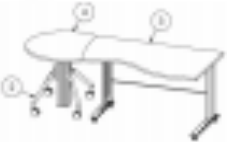
					One	Bid Two		
					Interiors	HCON International		
ITEM		DESCRIPTION	QTY	EXTENSION	on-Specified Altern	UNIT PRICE	QTY	
1		HIERARCHY 5-STAR STOOL WITH ARMS BLACK PLASTIC BASE SOFT CASTERS 22" - 33" COLOR: WILSONART CUSTOM REGIMENTAL RED SHELL	400	\$70,800.00	HCONE HCM05	\$ 105.99	400	
2		REFLECTION WORKSTATION 30"D X 60"L TOP 36"W X 23"D CASEBODY 36" HEIGHT SHELF AND 2 DOUBLE DOORS LOCK CONNECTING MAGNETS FOR HANGOUT STOOLS (2 LOCATIONS) UNASSEMBLED BULK PACKAGING. 236 LBS COLOR: WILSONART CUSTOM REGIMENTAL RED TOP WITH BLACK BEVELED ARMOR EDGE BLACK HPL CASEBODY WITH BLACK EDGE BANDING	126	\$141,853.32		\$ 1,043.04	126	
3		13" SQUARE SEAT, 24" FIXED SILVER HANGOUT STOOL BP (10 LBS.) COLOR: SILVER	252	\$15,566.04	HCONE HCR06-24	\$ 36.99	252	
4		TEACHER DESK COLOR: SPECIFY LAM- CONCRETE GROOVZ SPECIFY EDGE- GRAPHITE SPECIFY BASE- BLACK	35	\$45,784.90	HCONE HTD3072	\$ 595.99	35	
ITEM		DESCRIPTION	QTY	EXTENSION	on-Specified Altern	UNIT PRICE	QTY	

<b>KEY:</b>
Lowest bid on desired product
Alternate spec & bid
Recommended vendor

		<u>One</u>			<u>Bid Two</u>		
		<u>Interiors</u>			<u>HCON International</u>		
5		NSL FURNITURE PRODUCT TIDE FLIP TABLE 30" X 66" TIDE W/TUBULAR TBASE 29" FIXED HEIGHT HANDLE RELEASE AND INSERTS CASTERS UNASSEMBLED BULK PACKAGING. CLASS 70. 80 LBS. COLORS: DOVE GREY HPL TOP WITH BLACK BEVELED ARMOR EDGE. BLACK LEGS.	140	\$91,252.00	HCONE ST	\$ 579.99	140

<u>ITEM</u>		<u>DESCRIPTION</u>	<u>QTY</u>	<u>EXTENSION</u>	<u>Non-Specified Altern</u>	<u>UNIT PRICE</u>	<u>QTY</u>
6		IGNITION WK MID-BCK PNEU SWIVEL TILT BACK: HEIGHT ADJ ARM: HEIGHT AND WIDTH ADJ CASTER: SOFT BACK: MESH BACK FABRIC: GRADE: III UPHOLSTERY FABRIC SELECTION: MOXIE COLOR: CARBON BASALT BASETYPE: STANDARD BASE COLOR: CARBON/BASALT PAINT: FRAME: BLACK	45	\$15,899.40		\$ 332.75	45

<u>ITEM</u>		<u>DESCRIPTION</u>	<u>QTY</u>	<u>EXTENSION</u>	<u>Non-Specified Altern</u>	<u>UNIT PRICE</u>	<u>QTY</u>
7		POWER TOWER  COLOR: PLATINUM	70	\$18,022.20		\$ 361.75	70

<u>ITEM</u>		<u>DESCRIPTION</u>	<u>QTY</u>	<u>EXTENSION</u>	<u>Non-Specified Altern</u>	<u>UNIT PRICE</u>	<u>QTY</u>
-------------	--	--------------------	------------	------------------	-----------------------------	-------------------	------------



<b>KEY:</b>
Lowest bid on desired product
Alternate spec & bid
Recommended vendor

		<b>One</b>		<b>Bid Two</b>		
		<b>Interiors</b>		<b>HCON International</b>		
8	 <p>NSL FURNITURE PRODUCT ELEVATE 24" X 28.5" PLYMOUTH STUDENT DESK ADJUSTABLE HEIGHT PNEUMATIC BASE DUAL WHEEL SOFT TREAD LOCKING CASTERS &amp; GRAND HANK GLIDES 27.94"-42.94" OVERALL ADJUSTABLE HEIGHT 1 BACKPACK HOOK UNASSEMBLED PACKAGING - BULK, 55 LBS.</p> <p>COLORS: TOP - WILSONART MYSTIQUE NIGHT 4760-60 BLACK BEVELED LOTZ ARMOR EDGE BLACK FRAME FINISH</p>	400	\$147,780.00	HCONE HT093	\$ 175.99	400

<b>ITEM</b>	<b>DESCRIPTION</b>	<b>QTY</b>	<b>EXTENSION</b>	<b>on-Specified Alterna</b>	<b>UNIT PRICE</b>	<b>QTY</b>
9	 <p>HIGH RISE/SILVERADO ROUND OTTOMAN 18" X 18" CASTERS WRAP</p> <p>COLORS: WRAP AROUND OTTOMAN - ARC COM HIGH RISE PRIMARY #1 TOP - ARC COM SILVERADO 2 STEEL #41</p>	524	\$173,601.20	LF1511-G2	\$ 201.85	524

<b>ITEM</b>	<b>DESCRIPTION</b>	<b>QTY</b>	<b>EXTENSION</b>	<b>on-Specified Alterna</b>	<b>UNIT PRICE</b>	<b>QTY</b>
10	 <p>REPLAY® MOBILE OPEN BOOK NOOK BASE CABINET WITH 1" ADJUSTABLE SHELF 36" WIDTH, 16" DEPTH, 36" HEIGHT, FINISHED BOTH ENDS FULLY ASSEMBLED (CASTERS INSTALLED ONSITE BY OTHERS). BULK PACKAGING. 109 LBS.</p> <p>COLORS: TOP - WILSONART CUSTOM REGIMENTAL RED WITH BLACK EDGE BANDING CASEBODY - BLACK HPL WITH BLACK EDGE BANDING.</p>	36	\$20,490.84	HCONE TS047	\$ 388.99	36

<b>KEY:</b>
Lowest bid on desired product
Alternate spec & bid
Recommended vendor

		One Interiors			Bid Two HCON International		
ITEM		DESCRIPTION	QTY	EXTENSION	on-Specified Alterna	UNIT PRICE	QTY
11		QUOTE FOR SPECIAL CABINET CD1000 CUSTOM MOBILE CABINET WITH SHELF 48"W X 36"H X 18"D CASTERS FULLY ASSEMBLED (CASTERS INSTALLED ONSITE BY OTHERS) BULK PACKAGING. 113 LBS. COLORS: TOP - WILSONART CUSTOM REGIMENTAL RED WITH BLACK EDGE BANDING CASEBODY - BLACK HPL WITH BLACK EDGE BANDING.	45	\$27,773.10	HCONE TS049	\$ 475.99	45
12		SEED ROCKER FRAME- 18" COLOR: WILSONART CUSTOM REGIMENTAL RED SHELL PLATINUM FRAME	36	\$3,708.00	HCONE SCM14-18	\$ 99.99	36
13		C-TABLE 27" FIXED HEIGHT 18" WORKSURFACE 73P EDGE COLOR: LAM - PRESSED LINEN 4991-38 EDGE - BLUE GREY BASE - BLACK	18	\$4,509.00		\$ 278.85	18
ITEM		DESCRIPTION	QTY	EXTENSION	on-Specified Alterna	UNIT PRICE	QTY

<b>KEY:</b>
Lowest bid on desired product
Alternate spec & bid
Recommended vendor

**One**  
**Interiors**

**Bid Two**  
**HCON International**

14		C-TABLE MAX 29" FIXED HEIGHT ROUND WITH CURVE TOP 24" WORKSURFACE 73P EDGE	20	\$5,340.00		\$	298.89	20
		COLOR: LAM - PRESSED LINEN 4991-38 EDGE - BLUE GREY BASE - BLACK						

ITEM		DESCRIPTION	QTY	EXTENSION	on-Specified Alterna	UNIT PRICE	QTY
15		HUB LAMINATE TABLE 26" X 26" GANGING-WITH (2) GANGERS ASSEMBLIES SHIPPED PER UNIT BLACK NYSON GLIDES  COLOR: BASE FINISH - BLACK TOP LAM - PRESSED LINEN 4991-38 SIDE LAM - PRESSED LINEN 4991-38 BLACK POWER MODULE	4	\$3,186.00		\$ 789.25	4

ITEM		DESCRIPTION	QTY	EXTENSION	on-Specified Alterna	UNIT PRICE	QTY
16		HUB ARMLESS LOUNGE, CONTRAST, 26" X 78" GANGING- WITH GANGERS (2) GANGING ASSEMBLIES SHIPPED PER UNIT NO PRIVACY SCREEN NO MOISTURE BARRIER BLACK NYLON GLIDES  COLOR: BACK FABRIC- ARC COM SPINNAKER CHILI PEPPER #863027 SEAT/SIDE FABRIC- ARC COM EMPRESS SMOKE #23AC61882 BASE AND SEAT BACK UPRIGHT FINISH- BLACK	8	\$14,729.52		\$ 2,099.52	8

ITEM		DESCRIPTION	QTY	EXTENSION	on-Specified Alterna	UNIT PRICE	QTY
------	--	-------------	-----	-----------	----------------------	------------	-----



<b>KEY:</b>
Lowest bid on desired product
Alternate spec & bid
Recommended vendor

			<u>One</u>		<u>Bid Two</u>		
			<u>Interiors</u>		<u>HCON International</u>		
17		IGNITION TASK STOOL PNEU ADJ FOOTREST BACK: HEIGHT ADJ ARM: HEIGHT AND WIDTH ADJ CASTER: SOFT BACK: MESH BACK FABRIC: GRADE: III UPHOLSTERY FABRIC SELECTION: MOXIE--BASALT PAINT: FRAME: BLACK BASETYPE: BASE: STANDARD BASE COLOR: MOXIE - BASALT PAINT: FRAME: BLACK	48	\$18,055.68		\$ 332.90	48

<u>ITEM</u>		<u>DESCRIPTION</u>	<u>QTY</u>	<u>EXTENSION</u>	<u>Non-Specified Alternates</u>	<u>UNIT PRICE</u>	<u>QTY</u>
18		LYRA LOUNGE CHAIR UPH BACK SLED BASE CONTRAST 29"W X 29"D  NO MOISTURE BARRIER BLACK NYLON GLIDES BLACK BASE FINISH COLOR: OUTER SHELL – ARC COM SPINNAKER CHILI PEPPER #863027 BACK CUSHION – ARC COM EMPRESS SMOKE #23AC61882 SEAT CUSHION – ARC COM EMPRESS SMOKE #23AC61882 INNER ARM CUSHION – ARC COM SPINNAKER CHILI PEPPER #863027	16	\$22,980.96		\$ 1,726.55	16

<u>ITEM</u>		<u>DESCRIPTION</u>	<u>QTY</u>	<u>EXTENSION</u>	<u>Non-Specified Alternates</u>	<u>UNIT PRICE</u>	<u>QTY</u>
19		HIGH RISE/SILVERADO ROUND OTTOMAN 18" X 18" CASTERS WRAP COLOR: DESIGNTEX WEND HEAT	16	\$4,752.32	LF1511	\$ 201.85	16

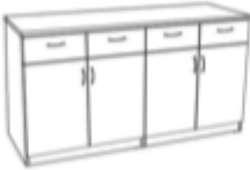
<b>KEY:</b>
Lowest bid on desired product
Alternate spec & bid
Recommended vendor

					One	Bid Two		
					Interiors	HCON International		
ITEM	DESCRIPTION	QTY	EXTENSION	Non-Specified Alternates	UNIT PRICE	QTY		
20	 <p>HYPERWORK 144" X 48" BOAT SHAPED CONFERENCE TABLE CUSTOMER 42" HEIGHT OPTIONAL BOX BASES ADD (4) COVE POWER UNITS- EACH WITH 2 POWER/2USB CENTERED AND EQUALLY SPACED COLOR: POWER COVE - SILVER LAMINATE- SHORELINE</p>	4	\$12,387.24	CES PL138THALF/ PL	\$ 2,388.85	4		
21	 <p>BUFFET CREDENZA 4 DRAWER TWO STORAGE COMPARTMENTS WITH ONE ADJUSTABLE SHELF EACH BEHIND FOUR DOORS 36" BUFFET HEIGHT 63.5" X 24" X 36" COLOR: SPECIFY LAM - SHORELINE SPECIFY PULLS- TBAR NICKLE</p>	4	\$4,986.28	CANDEX SO398	\$ 1,620.25	4		
22	 <p>CULINARY TABLE 60W X 30D X 35H **MODIFIED TO HAVE EM-9A CENTER TABLE BRACING KIT** **BAR IS NOT ALONG THE BACK, IT IS BEING MOVED/MODIFIED TO THE CENTER***</p>	6	\$3,163.32		\$ 299.75	6		
23	 <p>WORK TABLE CASTER KIT, SET OF 4</p>	6	\$338.46		\$ 15.75	6		

<b>KEY:</b>
Lowest bid on desired product
Alternate spec & bid
Recommended vendor

**One**

**Interiors**

**Bid Two**

**HCON International**

<u>ITEM</u>	<u>DESCRIPTION</u>	<u>QTY</u>	<u>EXTENSION</u>	<u>on-Specified Alternative</u>	<u>UNIT PRICE</u>	<u>QTY</u>
24	 <p>NPS® 18"-25" HEIGHT ADJUSTABLE DESIGNER STOOL COLOR: PERSIAN BLUE/BLACK</p>	190	\$18,050.00		\$ 90.75	190

<u>ITEM</u>	<u>DESCRIPTION</u>	<u>QTY</u>	<u>EXTENSION</u>	<u>on-Specified Alternative</u>	<u>UNIT PRICE</u>	<u>QTY</u>
25	 <p>NUCLEUSGUEST MULTI-PURPOSE CHAIR FOUR LEG STACKING FRAME ARM: FIXED ARM ALL SURFACE CASTER BACK: STRETCH BLACK FABRIC GRADE: III UPHOLSTERY FABRIC ELECTION: MOXIE--BASALT FRAME: BLACK COLOR: MOXIE -BASALT PAINT: FRAME: BLACK</p>	8	\$2,049.04		\$ 245.76	8

<u>ITEM</u>	<u>DESCRIPTION</u>	<u>QTY</u>	<u>EXTENSION</u>	<u>on-Specified Alternative</u>	<u>UNIT PRICE</u>	<u>QTY</u>
26	 <p>10500 SERIES 60W X 30D X 29-1/2H DBL PED DSK 3/2 RECT TOP LAMINATE: GRD L1 STANDARD LAMINATES COLOR: SHAKER CHERRY</p>	4	\$2,633.44	OFFICE SOURCES	\$ 587.95	4

<u>ITEM</u>	<u>DESCRIPTION</u>	<u>QTY</u>	<u>EXTENSION</u>	<u>on-Specified Alternative</u>	<u>UNIT PRICE</u>	<u>QTY</u>
-------------	--------------------	------------	------------------	---------------------------------	-------------------	------------



<b>KEY:</b>
Lowest bid on desired product
Alternate spec & bid
Recommended vendor

**One**  
**Interiors**

**Bid Two**  
**HCON International**

27		PRESIDE 20W X 72D X 36H HOSPITALITY CREDENZA LAMTOP: GR L1 STANDARD LAMINATES EDGE: SHAKER LAMCHASSIS: GR L1 STANDARD LAMINATES PULL: LOOP SATIN NICKEL CUTOUT: NO CUTOUT	5	\$5,928.60	CANDEX SO397	\$ 1,465.29	5
		COLOR: SHAKER CHERRY					
Total			\$895,620.86		Total		
Awarded			636,628.98				

<b>KEY:</b>
Lowest bid on desired product
Alternate spec & bid
Recommended vendor

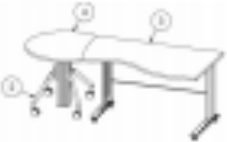
				Bid Three				
				McKinney Office Supply				
ITEM		DESCRIPTION	EXTENSION	Non-Specified Alternate	UNIT PRICE	QTY	EXTENSION	Non-Specified Alternate
1		HIERARCHY 5-STAR STOOL WITH ARMS BLACK PLASTIC BASE SOFT CASTERS 22" - 33" COLOR: WILSONART CUSTOM REGIMENTAL RED SHELL	\$42,396.00		\$ 166.61	400	\$66,644.00	
2		REFLECTION WORKSTATION 30"D X 60"L TOP 36"W X 23"D CASEBODY 36" HEIGHT SHELF AND 2 DOUBLE DOORS LOCK CONNECTING MAGNETS FOR HANGOUT STOOLS (2 LOCATIONS) UNASSEMBLED BULK PACKAGING. 236 LBS COLOR: WILSONART CUSTOM REGIMENTAL RED TOP WITH BLACK BEVELED ARMOR EDGE BLACK HPL CASEBODY WITH BLACK EDGE BANDING	\$131,423.04		\$ 1,246.19	126	\$157,019.94	
3		13" SQUARE SEAT, 24" FIXED SILVER HANGOUT STOOL BP (10 LBS.) COLOR: SILVER	\$9,321.48		\$ 64.23	252	\$16,185.96	
4		TEACHER DESK COLOR: SPECIFY LAM- CONCRETE GROOVZ SPECIFY EDGE- GRAPHITE SPECIFY BASE- BLACK	\$20,859.65		\$ 1,400.19	35	\$49,006.65	
ITEM		DESCRIPTION	EXTENSION	Non-Specified Alternate	UNIT PRICE	QTY	EXTENSION	Non-Specified Alternate



<b>KEY:</b>
Lowest bid on desired product
Alternate spec & bid
Recommended vendor

				<b>Bid Three</b>			
				<b>McKinney Office Supply</b>			
8		<p>NSL FURNITURE PRODUCT ELEVATE 24" X 28.5" PLYMOUTH STUDENT DESK ADJUSTABLE HEIGHT PNEUMATIC BASE DUAL WHEEL SOFT TREAD LOCKING CASTERS &amp; GRAND HANK GLIDES 27.94"-42.94" OVERALL ADJUSTABLE HEIGHT 1 BACKPACK HOOK UNASSEMBLED PACKAGING - BULK, 55 LBS.</p> <p>COLORS: TOP - WILSONART MYSTIQUE NIGHT 4760-60 BLACK BEVELED LOTZ ARMOR EDGE BLACK FRAME FINISH</p>	\$70,396.00		\$ 372.35	400	\$148,940.00

<u>ITEM</u>	<u>DESCRIPTION</u>	<u>EXTENSION</u>	<u>Non-Specified Alternate</u>	<u>UNIT PRICE</u>	<u>QTY</u>	<u>EXTENSION</u>	<u>Non-Specified Alternate</u>
9	 <p>HIGH RISE/SILVERADO ROUND OTTOMAN 18" X 18" CASTERS WRAP</p> <p>COLORS: WRAP AROUND OTTOMAN - ARC COM HIGH RISE PRIMARY #1 TOP - ARC COM SILVERADO 2 STEEL #41</p>	\$105,769.40	<p>KI MP18R/CST/FC</p>	\$ 422.49	524	\$221,384.76	

<u>ITEM</u>	<u>DESCRIPTION</u>	<u>EXTENSION</u>	<u>Non-Specified Alternate</u>	<u>UNIT PRICE</u>	<u>QTY</u>	<u>EXTENSION</u>	<u>Non-Specified Alternate</u>
10	 <p>REPLAY® MOBILE OPEN BOOK NOOK BASE CABINET WITH 1" ADJUSTABLE SHELF 36" WIDTH, 16" DEPTH, 36" HEIGHT, FINISHED BOTH ENDS FULLY ASSEMBLED (CASTERS INSTALLED ONSITE BY OTHERS). BULK PACKAGING. 109 LBS.</p> <p>COLORS: TOP - WILSONART CUSTOM REGIMENTAL RED WITH BLACK EDGE BANDING CASEBODY - BLACK HPL WITH BLACK EDGE BANDING.</p>	\$14,003.64		\$ 613.77	36	\$22,095.72	

<b>KEY:</b>
Lowest bid on desired product
Alternate spec & bid
Recommended vendor

ITEM	DESCRIPTION	EXTENSION	Bid Three				Non-Specified Alternate
			McKinney Office Supply				
			Non-Specified Alternate	UNIT PRICE	QTY	EXTENSION	Non-Specified Alternate
11	 <p>QUOTE FOR SPECIAL CABINET CD1000 CUSTOM MOBILE CABINET WITH SHELF 48"W X 36"H X 18"D CASTERS FULLY ASSEMBLED (CASTERS INSTALLED ONSITE BY OTHERS) BULK PACKAGING. 113 LBS. COLORS: TOP - WILSONART CUSTOM REGIMENTAL RED WITH BLACK EDGE BANDING CASEBODY - BLACK HPL WITH BLACK EDGE BANDING.</p>	\$21,419.55		\$ 668.91	45	\$30,100.95	Media Technologies DFT-48-3616S-OCB-L-MOB

ITEM	DESCRIPTION	EXTENSION	Bid Three				Non-Specified Alternate
			McKinney Office Supply				
			Non-Specified Alternate	UNIT PRICE	QTY	EXTENSION	Non-Specified Alternate
12	 <p>SEED ROCKER FRAME- 18" COLOR: WILSONART CUSTOM REGIMENTAL RED SHELL PLATINUM FRAME</p>	\$3,599.64		\$ 96.49	36	\$3,473.64	ScholarCraft SC5118XL-RC

ITEM	DESCRIPTION	EXTENSION	Bid Three				Non-Specified Alternate
			McKinney Office Supply				
			Non-Specified Alternate	UNIT PRICE	QTY	EXTENSION	Non-Specified Alternate
13	 <p>C-TABLE 27" FIXED HEIGHT 18" WORKSURFACE 73P EDGE COLOR: LAM - PRESSED LINEN 4991-38 EDGE - BLUE GREY BASE - BLACK</p>	\$5,019.30		\$ 255.00	18	\$4,590.00	Media Technologies O14OC-C0020-26

ITEM	DESCRIPTION	EXTENSION	Non-Specified Alternate	UNIT PRICE	QTY	EXTENSION	Non-Specified Alternate
------	-------------	-----------	-------------------------	------------	-----	-----------	-------------------------

<b>KEY:</b>
Lowest bid on desired product
Alternate spec & bid
Recommended vendor

				<b>Bid Three</b>				
				<b>McKinney Office Supply</b>				
14		C-TABLE MAX 29" FIXED HEIGHT ROUND WITH CURVE TOP 24" WORKSURFACE 73P EDGE COLOR: LAM - PRESSED LINEN 4991-38 EDGE - BLUE GREY BASE - BLACK	\$5,977.80		\$ 273.33	20	\$5,466.60	Moreco 91124

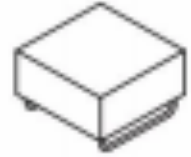
<u>ITEM</u>		<u>DESCRIPTION</u>	<u>EXTENSION</u>	<u>Non-Specified Alternate</u>	<u>UNIT PRICE</u>	<u>QTY</u>	<u>EXTENSION</u>	<u>Non-Specified Alternate</u>
15		HUB LAMINATE TABLE 26" X 26" GANGING-WITH (2) GANGERS ASSEMBLIES SHIPPED PER UNIT BLACK NYSON GLIDES COLOR: BASE FINISH - BLACK TOP LAM - PRESSED LINEN 4991-38 SIDE LAM - PRESSED LINEN 4991-38 BLACK POWER MODULE	\$3,157.00		\$ 863.48	4	\$3,453.92	Media Technologies DUC-2424-CL-21

<u>ITEM</u>		<u>DESCRIPTION</u>	<u>EXTENSION</u>	<u>Non-Specified Alternate</u>	<u>UNIT PRICE</u>	<u>QTY</u>	<u>EXTENSION</u>	<u>Non-Specified Alternate</u>
16		HUB ARMLESS LOUNGE, CONTRAST, 26" X 78" GANGING- WITH GANGERS (2) GANGING ASSEMBLIES SHIPPED PER UNIT NO PRIVACY SCREEN NO MOISTURE BARRIER BLACK NYLON GLIDES COLOR: BACK FABRIC- ARC COM SPINNAKER CHILI PEPPER #863027 SEAT/SIDE FABRIC- ARC COM EMPRESS SMOKE #23AC61882 BASE AND SEAT BACK UPRIGHT FINISH- BLACK	\$16,796.16		\$ 2,032.65	8	\$16,261.20	Media Technologies WNK-7230-G7

<u>ITEM</u>		<u>DESCRIPTION</u>	<u>EXTENSION</u>	<u>Non-Specified Alternate</u>	<u>UNIT PRICE</u>	<u>QTY</u>	<u>EXTENSION</u>	<u>Non-Specified Alternate</u>
-------------	--	--------------------	------------------	--------------------------------	-------------------	------------	------------------	--------------------------------



<b>KEY:</b>
Lowest bid on desired product
Alternate spec & bid
Recommended vendor

				<b>Bid Three</b>			
				<b>McKinney Office Supply</b>			
17		IGNITION TASK STOOL PNEU ADJ FOOTREST BACK: HEIGHT ADJ ARM: HEIGHT AND WIDTH ADJ CASTER: SOFT BACK: MESH BACK FABRIC: GRADE: III UPHOLSTERY FABRIC SELECTION: MOXIE--BASALT PAINT: FRAME: BLACK BASETYPE: BASE: STANDARD BASE COLOR: MOXIE - BASALT PAINT: FRAME: BLACK	\$15,979.20	\$ 331.00	48	\$15,888.00	9 to 5 1466-Y1-A9B-M21-C-BA9B-C6-AB

<b>ITEM</b>		<b>DESCRIPTION</b>	<b>EXTENSION</b>	<b>Non-Specified Alternate</b>	<b>UNIT PRICE</b>	<b>QTY</b>	<b>EXTENSION</b>	<b>Non-Specified Alternate</b>
18		LYRA LOUNGE CHAIR UPH BACK SLED BASE CONTRAST 29"W X 29"D  NO MOISTURE BARRIER BLACK NYLON GLIDES BLACK BASE FINISH COLOR: OUTER SHELL – ARC COM SPINNAKER CHILI PEPPER #863027 BACK CUSHION – ARC COM EMPRESS SMOKE #23AC61882 SEAT CUSHION – ARC COM EMPRESS SMOKE #23AC61882 INNER ARM CUSHION – ARC COM SPINNAKER CHILI PEPPER #863027	\$27,624.80		\$ 1,572.04	16	\$25,152.64	Moreco 1000CLR-GR3

<b>ITEM</b>		<b>DESCRIPTION</b>	<b>EXTENSION</b>	<b>Non-Specified Alternate</b>	<b>UNIT PRICE</b>	<b>QTY</b>	<b>EXTENSION</b>	<b>Non-Specified Alternate</b>
19		HIGH RISE/SILVERADO ROUND OTTOMAN 18" X 18" CASTERS WRAP COLOR: DESIGNTEX WEND HEAT	\$3,229.60	KI MP18R/CST/NC	\$ 302.27	16	\$4,836.32	

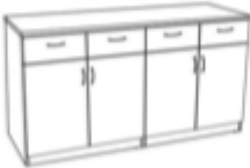
<b>KEY:</b>
Lowest bid on desired product
Alternate spec & bid
Recommended vendor



				Bid Three				
				McKinney Office Supply				
ITEM	DESCRIPTION	EXTENSION	Non-Specified Alternate	UNIT PRICE	QTY	EXTENSION	Non-Specified Alternate	
20	 <p>HYPERWORK 144" X 48" BOAT SHAPED CONFERENCE TABLE CUSTOMER 42" HEIGHT OPTIONAL BOX BASES ADD (4) COVE POWER UNITS- EACH WITH 2 POWER/2USB CENTERED AND EQUALLY SPACED COLOR: POWER COVE - SILVER LAMINATE- SHORELINE</p>	\$9,555.40		\$ 3,477.00	4	\$13,908.00	MEDIA TECHNOLOGIES PB24-CBT36/48144-29	
21	 <p>BUFFET CREDENZA 4 DRAWER TWO STORAGE COMPARTMENTS WITH ONE ADJUSTABLE SHELF EACH BEHIND FOUR DOORS 36" BUFFET HEIGHT 63.5" X 24" X 36" COLOR: SPECIFY LAM - SHORELINE SPECIFY PULLS- TBAR NICKLE</p>	\$6,481.00		\$ 1,413.00	4	\$5,652.00	MEDIA TECHNOLOGIES SBSCD2-302436-LL-Hinge-Pull-AB-CT	
22	 <p>CULINARY TABLE 60W X 30D X 35H **MODIFIED TO HAVE EM-9A CENTER TABLE BRACING KIT** **BAR IS NOT ALONG THE BACK, IT IS BEING MOVED/MODIFIED TO THE CENTER***</p>	\$1,798.50		\$ 526.44	6	\$3,158.64	MEDIA TECHNOLOGIES CUSTOM	
23	 <p>WORK TABLE CASTER KIT, SET OF 4</p>	\$94.50		\$ 51.22	6	\$307.32	MEDIA TECHNOLOGIES 4C	



<b>KEY:</b>
Lowest bid on desired product
Alternate spec & bid
Recommended vendor

				<b>Bid Three</b>				
				<b>McKinney Office Supply</b>				
27		PRESIDE 20W X 72D X 36H HOSPITALITY CREDENZA LAMTOP: GR L1 STANDARD LAMINATES EDGE: SHAKER LAMCHASSIS: GR L1 STANDARD LAMINATES PULL: LOOP SATIN NICKEL CUTOUT: NO CUTOUT	\$7,326.45		\$ 1,080.66	5	\$5,403.30	GLOBAL Z2072SCSC
		COLOR: SHAKER CHERRY						
				\$665,283.34			Total	\$965,710.40
							Awarded	\$71,123.54

<b>KEY:</b>
Lowest bid on desired product
Alternate spec & bid
Recommended vendor

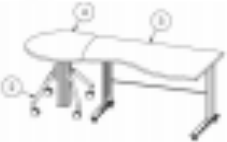
						<b>Bid Four</b>			<b>Bid Five</b>		
						<b>Meteor Education</b>			<b>Lone Star Furnishings</b>		
<u>ITEM</u>		<u>DESCRIPTION</u>	<u>UNIT PRICE</u>	<u>QTY</u>	<u>EXTENSION</u>	<u>Non-Specified Alternate</u>	<u>UNIT PRICE</u>	<u>QTY</u>	<u>Non-Specified Alternate</u>	<u>UNIT PRICE</u>	<u>QTY</u>
1		HIERARCHY 5-STAR STOOL WITH ARMS BLACK PLASTIC BASE SOFT CASTERS 22" - 33" COLOR: WILSONART CUSTOM REGIMENTAL RED SHELL	\$ 347.56	400	\$139,024.00	Smith System Grove Adjustable stool with Casters, Custom Color Match for Shell - Regimental Red, model 33842	\$ 166.64	400			
2		REFLECTION WORKSTATION 30"D X 60"L TOP 36"W X 23"D CASEBODY 36" HEIGHT SHELF AND 2 DOUBLE DOORS LOCK CONNECTING MAGNETS FOR HANGOUT STOOLS (2 LOCATIONS) UNASSEMBLED BULK PACKAGING. 236 LBS COLOR: WILSONART CUSTOM REGIMENTAL RED TOP WITH BLACK BEVELED ARMOR EDGE BLACK HPL CASEBODY WITH BLACK EDGE BANDING	\$ 1,101.64	126	\$138,806.64	Saffe BMWHSC233636S Beechwood Mobile Cabinet Workstation, 1/2 Unt, Storage Cabinet, 24d x 36w x 36h, Casters, Curved Collaboration	\$ 929.99	126			
3		13" SQUARE SEAT, 24" FIXED SILVER HANGOUT STOOL BP (10 LBS.) COLOR: SILVER	\$ 66.36	252	\$16,722.72	Furmax Furniture	\$ 30.88	252			
4		TEACHER DESK COLOR: SPECIFY LAM- CONCRETE GROOVZ SPECIFY EDGE- GRAPHITE SPECIFY BASE- BLACK	\$ 1,650.23	35	\$57,758.05	Instructor Desk model CLTCWV24365429G-MMP54-ATSXVC-MBBF-ATSXROFPHA3232C-	\$ 1,507.19	35			
<u>ITEM</u>		<u>DESCRIPTION</u>	<u>UNIT PRICE</u>	<u>QTY</u>	<u>EXTENSION</u>	<u>Non-Specified Alternate</u>	<u>UNIT PRICE</u>	<u>QTY</u>	<u>Non-Specified Alternate</u>	<u>UNIT PRICE</u>	<u>QTY</u>



<b>KEY:</b>
Lowest bid on desired product
Alternate spec & bid
Recommended vendor

			<b>Bid Four</b>			<b>Bid Five</b>		
			<b>Meteor Education</b>			<b>Lone Star Furnishings</b>		
8		<p>NSL FURNITURE PRODUCT ELEVATE 24" X 28.5" PLYMOUTH STUDENT DESK ADJUSTABLE HEIGHT PNEUMATIC BASE DUAL WHEEL SOFT TREAD LOCKING CASTERS &amp; GRAND HANK GLIDES 27.94"-42.94" OVERALL ADJUSTABLE HEIGHT 1 BACKPACK HOOK UNASSEMBLED PACKAGING - BULK, 55 LBS.</p> <p>COLORS: TOP - WILSONART MYSTIQUE NIGHT 4760-60 BLACK BEVELED LOTZ ARMOR EDGE BLACK FRAME FINISH</p>	\$ 398.66	400	\$159,464.00	Smith System model 01632V# with 24"x28.5" Top, HPL with Black mechanically fastened 4mm edgeband, black fram constructed of cold rolled steel with column of steel, aluminum and plastic.	\$ 357.00	400

<u>ITEM</u>	<u>DESCRIPTION</u>	<u>UNIT PRICE</u>	<u>QTY</u>	<u>EXTENSION</u>	<u>Non-Specified Alternate</u>	<u>UNIT PRICE</u>	<u>QTY</u>
9	 <p>HIGH RISE/SILVERADO ROUND OTTOMAN 18" X 18" CASTERS WRAP</p> <p>COLORS: WRAP AROUND OTTOMAN - ARC COM HIGH RISE PRIMARY #1 TOP - ARC COM SILVERADO 2 STEEL #41</p>	\$ 209.77	524	\$109,919.48		\$ 227.07	524

<u>ITEM</u>	<u>DESCRIPTION</u>	<u>UNIT PRICE</u>	<u>QTY</u>	<u>EXTENSION</u>	<u>Non-Specified Alternate</u>	<u>UNIT PRICE</u>	<u>QTY</u>
10	 <p>REPLAY® MOBILE OPEN BOOK NOOK BASE CABINET WITH 1" ADJUSTABLE SHELF 36" WIDTH, 16" DEPTH, 36" HEIGHT, FINISHED BOTH ENDS FULLY ASSEMBLED (CASTERS INSTALLED ONSITE BY OTHERS). BULK PACKAGING. 109 LBS.</p> <p>COLORS: TOP - WILSONART CUSTOM REGIMENTAL RED WITH BLACK EDGE BANDING CASEBODY - BLACK HPL WITH BLACK EDGE BANDING.</p>	\$ 541.02	36	\$19,476.72	Saffe BMBCSS163636C-S Beechwood Mobile Bookcase, Single Sided, 16d x 36w x 36h, Casters	\$ 431.20	36



<b>KEY:</b>
Lowest bid on desired product
Alternate spec & bid
Recommended vendor

			<b>Bid Four</b>			<b>Bid Five</b>		
			<b>Meteor Education</b>			<b>Lone Star Furnishings</b>		
14		C-TABLE MAX 29" FIXED HEIGHT ROUND WITH CURVE TOP 24" WORKSURFACE 73P EDGE COLOR: LAM - PRESSED LINEN 4991-38 EDGE - BLUE GREY BASE - BLACK	\$ 195.60	20	\$3,912.00		\$ 279.55	20

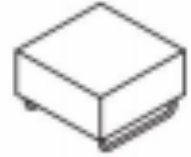
<u>ITEM</u>		<u>DESCRIPTION</u>	<u>UNIT PRICE</u>	<u>QTY</u>	<u>EXTENSION</u>	<u>Non-Specified Alternate</u>	<u>UNIT PRICE</u>	<u>QTY</u>
15		HUB LAMINATE TABLE 26" X 26" GANGING-WITH (2) GANGERS ASSEMBLIES SHIPPED PER UNIT BLACK NYSON GLIDES COLOR: BASE FINISH - BLACK TOP LAM - PRESSED LINEN 4991-38 SIDE LAM - PRESSED LINEN 4991-38 BLACK POWER MODULE	\$ 513.14	4	\$2,052.56		\$ 873.30	4

<u>ITEM</u>		<u>DESCRIPTION</u>	<u>UNIT PRICE</u>	<u>QTY</u>	<u>EXTENSION</u>	<u>Non-Specified Alternate</u>	<u>UNIT PRICE</u>	<u>QTY</u>
16		HUB ARMLESS LOUNGE, CONTRAST, 26" X 78" GANGING- WITH GANGERS (2) GANGING ASSEMBLIES SHIPPED PER UNIT NO PRIVACY SCREEN NO MOISTURE BARRIER BLACK NYLON GLIDES COLOR: BACK FABRIC- ARC COM SPINNAKER CHILI PEPPER #863027 SEAT/SIDE FABRIC- ARC COM EMPRESS SMOKE #23AC61882 BASE AND SEAT BACK UPRIGHT FINISH- BLACK	\$ 2,050.40	8	\$16,403.20		\$ 2,101.94	8

<u>ITEM</u>		<u>DESCRIPTION</u>	<u>UNIT PRICE</u>	<u>QTY</u>	<u>EXTENSION</u>	<u>Non-Specified Alternate</u>	<u>UNIT PRICE</u>	<u>QTY</u>
-------------	--	--------------------	-------------------	------------	------------------	--------------------------------	-------------------	------------



<b>KEY:</b>
Lowest bid on desired product
Alternate spec & bid
Recommended vendor

			<b>Bid Four</b>			<b>Bid Five</b>		
			<b>Meteor Education</b>			<b>Lone Star Furnishings</b>		
17		IGNITION TASK STOOL PNEU ADJ FOOTREST BACK: HEIGHT ADJ ARM: HEIGHT AND WIDTH ADJ CASTER: SOFT BACK: MESH BACK FABRIC: GRADE: III UPHOLSTERY FABRIC SELECTION: MOXIE--BASALT PAINT: FRAME: BLACK BASETYPE: BASE: STANDARD BASE COLOR: MOXIE - BASALT PAINT: FRAME: BLACK	\$ 433.40	48	\$20,803.20		\$ 399.75	48

<b>ITEM</b>		<b>DESCRIPTION</b>	<b>UNIT PRICE</b>	<b>QTY</b>	<b>EXTENSION</b>	<b>Non-Specified Alternate</b>	<b>UNIT PRICE</b>	<b>QTY</b>
18		LYRA LOUNGE CHAIR UPH BACK SLED BASE CONTRAST 29"W X 29"D  NO MOISTURE BARRIER BLACK NYLON GLIDES BLACK BASE FINISH COLOR: OUTER SHELL – ARC COM SPINNAKER CHILI PEPPER #863027 BACK CUSHION – ARC COM EMPRESS SMOKE #23AC61882 SEAT CUSHION – ARC COM EMPRESS SMOKE #23AC61882 INNER ARM CUSHION – ARC COM SPINNAKER CHILI PEPPER #863027	\$ 1,097.76	16	\$17,564.16		\$ 1,661.36	16

<b>ITEM</b>		<b>DESCRIPTION</b>	<b>UNIT PRICE</b>	<b>QTY</b>	<b>EXTENSION</b>	<b>Non-Specified Alternate</b>	<b>UNIT PRICE</b>	<b>QTY</b>
19		HIGH RISE/SILVERADO ROUND OTTOMAN 18" X 18" CASTERS WRAP COLOR: DESIGNTEX WEND HEAT	\$ 209.77	16	\$3,356.32		\$ 202.74	16

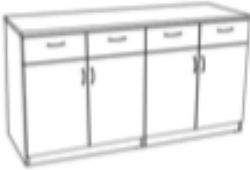
<b>KEY:</b>
Lowest bid on desired product
Alternate spec & bid
Recommended vendor

ITEM	DESCRIPTION	Bid Four Meteor Education			Bid Five Lone Star Furnishings		
		UNIT PRICE	QTY	EXTENSION	Non-Specified Alternate	UNIT PRICE	QTY
20	 <p>HYPERWORK 144" X 48" BOAT SHAPED CONFERENCE TABLE CUSTOMER 42" HEIGHT OPTIONAL BOX BASES ADD (4) COVE POWER UNITS- EACH WITH 2 POWER/2USB CENTERED AND EQUALLY SPACED COLOR: POWER COVE - SILVER LAMINATE- SHORELINE</p>	\$ 2,117.40	4	\$8,469.60	HON Preside 144" x 48" Boat Shaped Conference Table with Standing Height Bases and Power- HTLB484144.G.G2, (2) HTGPWR-3P-2B-2U, HTLCUBES144	\$ 2,683.20	4
21	 <p>BUFFET CREDENZA 4 DRAWER TWO STORAGE COMPARTMENTS WITH ONE ADJUSTABLE SHELF EACH BEHIND FOUR DOORS 36" BUFFET HEIGHT 63.5" X 24" X 36" COLOR: SPECIFY LAM - SHORELINE SPECIFY PULLS- TBAR NICKLE</p>	\$ 1,660.68	4	\$6,642.72	HON Preside Credenza with Shelves 57"w x 20" d x 36"h - HTLCRED57S	\$ 1,208.54	4
22	 <p>CULINARY TABLE 60W X 30D X 35H **MODIFIED TO HAVE EM-9A CENTER TABLE BRACING KIT** **BAR IS NOT ALONG THE BACK, IT IS BEING MOVED/MODIFIED TO THE CENTER***</p>	\$ 1,386.40	6	\$8,318.40		\$ 449.32	6
23	 <p>WORK TABLE CASTER KIT, SET OF 4</p>	\$ 40.77	6	\$244.62		\$ 55.13	6



<b>KEY:</b>
Lowest bid on desired product
Alternate spec & bid
Recommended vendor

			<b>Bid Four</b>			<b>Bid Five</b>		
			<b>Meteor Education</b>			<b>Lone Star Furnishings</b>		
27		PRESIDE 20W X 72D X 36H HOSPITALITY CREDENZA LAMTOP: GR L1 STANDARD LAMINATES EDGE: SHAKER LAMCHASSIS: GR L1 STANDARD LAMINATES PULL: LOOP SATIN NICKEL CUTOUT: NO CUTOUT COLOR: SHAKER CHERRY	\$ 1,017.63	5	\$5,088.15		\$ 1,298.93	5

Total \$929,509.81  
**Awarded \$113,275.80**

Freight  
 Installation  
 Total

<b>KEY:</b>
Lowest bid on desired product
Alternate spec & bid
Recommended vendor

ITEM		DESCRIPTION	EXTENSION	Bid Six			
				OCOP Express			
				Non-Specified Alternate	UNIT PRICE	QTY	EXTENSION
1		HIERARCHY 5-STAR STOOL WITH ARMS BLACK PLASTIC BASE SOFT CASTERS 22" - 33" COLOR: WILSONART CUSTOM REGIMENTAL RED SHELL	\$66,656.00		\$ 185.00	400	\$74,000.00

ITEM		DESCRIPTION	EXTENSION	Bid Six			
				OCOP Express			
				Non-Specified Alternate	UNIT PRICE	QTY	EXTENSION
2		REFLECTION WORKSTATION 30"D X 60"L TOP 36"W X 23"D CASEBODY 36" HEIGHT SHELF AND 2 DOUBLE DOORS LOCK CONNECTING MAGNETS FOR HANGOUT STOOLS (2 LOCATIONS) UNASSEMBLED BULK PACKAGING. 236 LBS COLOR: WILSONART CUSTOM REGIMENTAL RED TOP WITH BLACK BEVELED ARMOR EDGE BLACK HPL CASEBODY WITH BLACK EDGE BANDING	\$117,178.74		N/B	126	

ITEM		DESCRIPTION	EXTENSION	Bid Six			
				OCOP Express			
				Non-Specified Alternate	UNIT PRICE	QTY	EXTENSION
3		13" SQUARE SEAT, 24" FIXED SILVER HANGOUT STOOL BP (10 LBS.) COLOR: SILVER	\$7,781.76	FLF-4ET312024SSVRGG	\$ 33.00	252	\$8,316.00

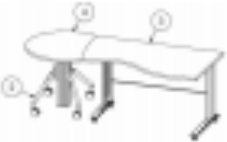
ITEM		DESCRIPTION	EXTENSION	Bid Six			
				OCOP Express			
				Non-Specified Alternate	UNIT PRICE	QTY	EXTENSION
4		TEACHER DESK COLOR: SPECIFY LAM- CONCRETE GROOVZ SPECIFY EDGE- GRAPHITE SPECIFY BASE- BLACK	\$52,751.65		\$ 1,466.85	35	\$51,339.75

ITEM		DESCRIPTION	EXTENSION	Non-Specified Alternate	UNIT PRICE	QTY	EXTENSION
------	--	-------------	-----------	-------------------------	------------	-----	-----------



<b>KEY:</b>
Lowest bid on desired product
Alternate spec & bid
Recommended vendor

				<b>Bid Six</b>			
				<b>OCOP Express</b>			
8		<p>NSL FURNITURE PRODUCT ELEVATE 24" X 28.5" PLYMOUTH STUDENT DESK ADJUSTABLE HEIGHT PNEUMATIC BASE DUAL WHEEL SOFT TREAD LOCKING CASTERS &amp; GRAND HANK GLIDES 27.94"-42.94" OVERALL ADJUSTABLE HEIGHT 1 BACKPACK HOOK UNASSEMBLED PACKAGING - BULK, 55 LBS.</p> <p>COLORS: TOP - WILSONART MYSTIQUE NIGHT 4760-60 BLACK BEVELED LOTZ ARMOR EDGE BLACK FRAME FINISH</p>	\$142,800.00		N/B	400	

<u>ITEM</u>	<u>DESCRIPTION</u>	<u>EXTENSION</u>	<u>Non-Specified Alternate</u>	<u>UNIT PRICE</u>	<u>QTY</u>	<u>EXTENSION</u>
9	 <p>HIGH RISE/SILVERADO ROUND OTTOMAN 18" X 18" CASTERS WRAP</p> <p>COLORS: WRAP AROUND OTTOMAN - ARC COM HIGH RISE PRIMARY #1 TOP - ARC COM SILVERADO 2 STEEL #41</p>	\$118,984.68		N/B	524	

<u>ITEM</u>	<u>DESCRIPTION</u>	<u>EXTENSION</u>	<u>Non-Specified Alternate</u>	<u>UNIT PRICE</u>	<u>QTY</u>	<u>EXTENSION</u>
10	 <p>REPLAY® MOBILE OPEN BOOK NOOK BASE CABINET WITH 1" ADJUSTABLE SHELF 36" WIDTH, 16" DEPTH, 36" HEIGHT, FINISHED BOTH ENDS FULLY ASSEMBLED (CASTERS INSTALLED ONSITE BY OTHERS). BULK PACKAGING. 109 LBS.</p> <p>COLORS: TOP - WILSONART CUSTOM REGIMENTAL RED WITH BLACK EDGE BANDING CASEBODY - BLACK HPL WITH BLACK EDGE BANDING.</p>	\$15,523.20		N/B	36	

<b>KEY:</b>
Lowest bid on desired product
Alternate spec & bid
Recommended vendor

ITEM	DESCRIPTION	EXTENSION	Bid Six			
			Non-Specified Alternate	UNIT PRICE	QTY	EXTENSION
11	 <p>QUOTE FOR SPECIAL CABINET CD1000 CUSTOM MOBILE CABINET WITH SHELF 48"W X 36"H X 18"D CASTERS FULLY ASSEMBLED (CASTERS INSTALLED ONSITE BY OTHERS) BULK PACKAGING. 113 LBS. COLORS: TOP - WILSONART CUSTOM REGIMENTAL RED WITH BLACK EDGE BANDING CASEBODY - BLACK HPL WITH BLACK EDGE BANDING.</p>	\$25,095.15		N/B	45	

ITEM	DESCRIPTION	EXTENSION	Bid Six			
			Non-Specified Alternate	UNIT PRICE	QTY	EXTENSION
12	 <p>SEED ROCKER FRAME- 18" COLOR: WILSONART CUSTOM REGIMENTAL RED SHELL PLATINUM FRAME</p>	\$3,661.20		\$ 110.50	36	\$3,978.00

ITEM	DESCRIPTION	EXTENSION	Bid Six			
			Non-Specified Alternate	UNIT PRICE	QTY	EXTENSION
13	 <p>C-TABLE 27" FIXED HEIGHT 18" WORKSURFACE 73P EDGE COLOR: LAM - PRESSED LINEN 4991-38 EDGE - BLUE GREY BASE - BLACK</p>	\$4,694.40		N/B	18	

ITEM	DESCRIPTION	EXTENSION	Non-Specified Alternate	UNIT PRICE	QTY	EXTENSION
------	-------------	-----------	-------------------------	------------	-----	-----------

<b>KEY:</b>
Lowest bid on desired product
Alternate spec & bid
Recommended vendor

				<b>Bid Six</b>			
				<b>OCOP Express</b>			
14		C-TABLE MAX 29" FIXED HEIGHT ROUND WITH CURVE TOP 24" WORKSURFACE 73P EDGE COLOR: LAM - PRESSED LINEN 4991-38 EDGE - BLUE GREY BASE - BLACK	\$5,591.00		N/B	20	

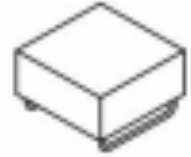
<u>ITEM</u>		<u>DESCRIPTION</u>	<u>EXTENSION</u>	<u>Non-Specified Alternate</u>	<u>UNIT PRICE</u>	<u>QTY</u>	<u>EXTENSION</u>
15		HUB LAMINATE TABLE 26" X 26" GANGING-WITH (2) GANGERS ASSEMBLIES SHIPPED PER UNIT BLACK NYSON GLIDES COLOR: BASE FINISH - BLACK TOP LAM - PRESSED LINEN 4991-38 SIDE LAM - PRESSED LINEN 4991-38 BLACK POWER MODULE	\$3,493.20		N/B	4	

<u>ITEM</u>		<u>DESCRIPTION</u>	<u>EXTENSION</u>	<u>Non-Specified Alternate</u>	<u>UNIT PRICE</u>	<u>QTY</u>	<u>EXTENSION</u>
16		HUB ARMLESS LOUNGE, CONTRAST, 26" X 78" GANGING- WITH GANGERS (2) GANGING ASSEMBLIES SHIPPED PER UNIT NO PRIVACY SCREEN NO MOISTURE BARRIER BLACK NYLON GLIDES COLOR: BACK FABRIC- ARC COM SPINNAKER CHILI PEPPER #863027 SEAT/SIDE FABRIC- ARC COM EMPRESS SMOKE #23AC61882 BASE AND SEAT BACK UPRIGHT FINISH- BLACK	\$16,815.52		N/B	8	

<u>ITEM</u>		<u>DESCRIPTION</u>	<u>EXTENSION</u>	<u>Non-Specified Alternate</u>	<u>UNIT PRICE</u>	<u>QTY</u>	<u>EXTENSION</u>
-------------	--	--------------------	------------------	--------------------------------	-------------------	------------	------------------



<b>KEY:</b>
Lowest bid on desired product
Alternate spec & bid
Recommended vendor

				<b>Bid Six</b>			
				<b>OCOP Express</b>			
17		IGNITION TASK STOOL PNEU ADJ FOOTREST BACK: HEIGHT ADJ ARM: HEIGHT AND WIDTH ADJ CASTER: SOFT BACK: MESH BACK FABRIC: GRADE: III UPHOLSTERY FABRIC SELECTION: MOXIE--BASALT PAINT: FRAME: BLACK BASETYPE: BASE: STANDARD BASE COLOR: MOXIE - BASALT PAINT: FRAME: BLACK	\$19,188.00	\$	364.41	48	\$17,491.68

<b>ITEM</b>		<b>DESCRIPTION</b>	<b>EXTENSION</b>	<b>Non-Specified Alternate</b>	<b>UNIT PRICE</b>	<b>QTY</b>	<b>EXTENSION</b>
18		LYRA LOUNGE CHAIR UPH BACK SLED BASE CONTRAST 29"W X 29"D NO MOISTURE BARRIER BLACK NYLON GLIDES BLACK BASE FINISH COLOR: OUTER SHELL – ARC COM SPINNAKER CHILI PEPPER #863027 BACK CUSHION – ARC COM EMPRESS SMOKE #23AC61882 SEAT CUSHION – ARC COM EMPRESS SMOKE #23AC61882 INNER ARM CUSHION – ARC COM SPINNAKER CHILI PEPPER #863027	\$26,581.76		N/B	16	

<b>ITEM</b>		<b>DESCRIPTION</b>	<b>EXTENSION</b>	<b>Non-Specified Alternate</b>	<b>UNIT PRICE</b>	<b>QTY</b>	<b>EXTENSION</b>
19		HIGH RISE/SILVERADO ROUND OTTOMAN 18" X 18" CASTERS WRAP COLOR: DESIGNTEX WEND HEAT	\$3,243.84		N/B	16	

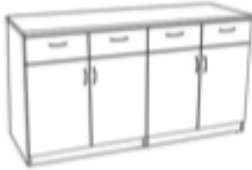
<b>KEY:</b>
Lowest bid on desired product
Alternate spec & bid
Recommended vendor

				<b>Bid Six</b>			
				<b>OCOP Express</b>			
<u>ITEM</u>	<u>DESCRIPTION</u>	<u>EXTENSION</u>	<u>Non-Specified Alternate</u>	<u>UNIT PRICE</u>	<u>QTY</u>	<u>EXTENSION</u>	
20	 <p>HYPERWORK 144" X 48" BOAT SHAPED CONFERENCE TABLE CUSTOMER 42" HEIGHT OPTIONAL BOX BASES ADD (4) COVE POWER UNITS- EACH WITH 2 POWER/2USB CENTERED AND EQUALLY SPACED COLOR: POWER COVE - SILVER LAMINATE- SHORELINE</p>	\$10,732.80		\$ 1,974.00	4	\$7,896.00	
21	 <p>BUFFET CREDENZA 4 DRAWER TWO STORAGE COMPARTMENTS WITH ONE ADJUSTABLE SHELF EACH BEHIND FOUR DOORS 36" BUFFET HEIGHT 63.5" X 24" X 36" COLOR: SPECIFY LAM - SHORELINE SPECIFY PULLS- TBAR NICKLE</p>	\$4,834.16		\$ 1,330.00	4	\$5,320.00	
22	 <p>CULINARY TABLE 60W X 30D X 35H **MODIFIED TO HAVE EM-9A CENTER TABLE BRACING KIT** **BAR IS NOT ALONG THE BACK, IT IS BEING MOVED/MODIFIED TO THE CENTER**</p>	\$2,695.92		\$ 540.24	6	\$3,241.44	
23	 <p>WORK TABLE CASTER KIT, SET OF 4</p>	\$330.78		\$ 68.80	6	\$412.80	

<b>KEY:</b>
Lowest bid on desired product
Alternate spec & bid
Recommended vendor

ITEM	DESCRIPTION	EXTENSION	Bid Six OCOP Express			
			Non-Specified Alternate	UNIT PRICE	QTY	EXTENSION
24	 <p>NPS® 18"-25" HEIGHT ADJUSTABLE DESIGNER STOOL COLOR: PERSIAN BLUE/BLACK</p>	\$13,051.10		N/B	190	

ITEM	DESCRIPTION	EXTENSION	Bid Six OCOP Express			
			Non-Specified Alternate	UNIT PRICE	QTY	EXTENSION
25	 <p>NUCLEUSGUEST MULTI-PURPOSE CHAIR FOUR LEG STACKING FRAME ARM: FIXED ARM ALL SURFACE CASTER BACK: STRETCH BLACK FABRIC GRADE: III UPHOLSTERY FABRIC ELECTION: MOXIE--BASALT FRAME: BLACK COLOR: MOXIE -BASALT PAINT: FRAME: BLACK</p>	\$2,305.12		\$ 245.63	8	\$1,965.04

ITEM	DESCRIPTION	EXTENSION	Bid Six OCOP Express			
			Non-Specified Alternate	UNIT PRICE	QTY	EXTENSION
26	 <p>10500 SERIES 60W X 30D X 29-1/2H DBL PED DSK 3/2 RECT TOP LAMINATE: GRD L1 STANDARD LAMINATES COLOR: SHAKER CHERRY</p>	\$2,736.44		\$ 602.36	4	\$2,409.44

ITEM	DESCRIPTION	EXTENSION	Non-Specified Alternate	UNIT PRICE	QTY	EXTENSION

<b>KEY:</b>
Lowest bid on desired product
Alternate spec & bid
Recommended vendor

		<b>Bid Six</b>			
		<b>OCOP Express</b>			
27	 <p>PRESIDE 20W X 72D X 36H HOSPITALITY CREDENZA  LAMTOP: GR L1 STANDARD LAMINATES  EDGE: SHAKER  LAMCHASSIS: GR L1 STANDARD LAMINATES  PULL: LOOP SATIN NICKEL  CUTOUT: NO CUTOUT  COLOR: SHAKER CHERRY</p>	\$6,494.65	\$ 1,143.72	5	\$5,718.60

\$761,374.97  
\$4,551.47  
\$40,034.67  



---

\$805,961.11

<b>KEY:</b>
Lowest bid on desired product
Alternate spec & bid
Recommended vendor

**Bid Seven  
School Specialty**

ITEM		DESCRIPTION	Non-Specified Alternate	UNIT PRICE	QTY	EXTENSION	Non-Specified Alternate
1		HIERARCHY 5-STAR STOOL WITH ARMS BLACK PLASTIC BASE SOFT CASTERS 22" - 33" COLOR: WILSONART CUSTOM REGIMENTAL RED SHELL		\$ 212.41	400	\$84,964.00	

ITEM		DESCRIPTION	Non-Specified Alternate	UNIT PRICE	QTY	EXTENSION	Non-Specified Alternate
2		REFLECTION WORKSTATION 30"D X 60"L TOP 36"W X 23"D CASEBODY 36" HEIGHT SHELF AND 2 DOUBLE DOORS LOCK CONNECTING MAGNETS FOR HANGOUT STOOLS (2 LOCATIONS) UNASSEMBLED BULK PACKAGING. 236 LBS COLOR: WILSONART CUSTOM REGIMENTAL RED TOP WITH BLACK BEVELED ARMOR EDGE BLACK HPL CASEBODY WITH BLACK EDGE BANDING		\$ 1,368.07	126	\$172,376.82	

ITEM		DESCRIPTION	Non-Specified Alternate	UNIT PRICE	QTY	EXTENSION	Non-Specified Alternate
3		13" SQUARE SEAT, 24" FIXED SILVER HANGOUT STOOL BP (10 LBS.) COLOR: SILVER		\$ 62.37	252	\$15,717.24	

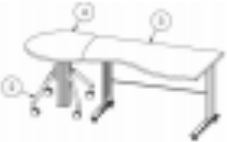
ITEM		DESCRIPTION	Non-Specified Alternate	UNIT PRICE	QTY	EXTENSION	Non-Specified Alternate
4		TEACHER DESK COLOR: SPECIFY LAM- CONCRETE GROOVZ SPECIFY EDGE- GRAPHITE SPECIFY BASE- BLACK		\$ 1,815.51	35	\$63,542.85	

ITEM		DESCRIPTION	Non-Specified Alternate	UNIT PRICE	QTY	EXTENSION	Non-Specified Alternate
------	--	-------------	-------------------------	------------	-----	-----------	-------------------------



<b>KEY:</b>
Lowest bid on desired product
Alternate spec & bid
Recommended vendor

**Bid Seven  
School Specialty**

8		<p>NSL FURNITURE PRODUCT ELEVATE 24" X 28.5" PLYMOUTH STUDENT DESK ADJUSTABLE HEIGHT PNEUMATIC BASE DUAL WHEEL SOFT TREAD LOCKING CASTERS &amp; GRAND HANK GLIDES 27.94"-42.94" OVERALL ADJUSTABLE HEIGHT 1 BACKPACK HOOK UNASSEMBLED PACKAGING - BULK, 55 LBS.</p> <p>COLORS: TOP - WILSONART MYSTIQUE NIGHT 4760-60 BLACK BEVELED LOTZ ARMOR EDGE BLACK FRAME FINISH</p>	\$	392.59	400	\$157,036.00	
---	---	--	----	--------	-----	--------------	--

<u>ITEM</u>	<u>DESCRIPTION</u>	<u>Non-Specified Alternate</u>	<u>UNIT PRICE</u>	<u>QTY</u>	<u>EXTENSION</u>	<u>Non-Specified Alternate</u>	
9	 <p>HIGH RISE/SILVERADO ROUND OTTOMAN 18" X 18" CASTERS WRAP</p> <p>COLORS: WRAP AROUND OTTOMAN - ARC COM HIGH RISE PRIMARY #1 TOP - ARC COM SILVERADO 2 STEEL #41</p>		\$	291.34	524	\$152,662.16	

<u>ITEM</u>	<u>DESCRIPTION</u>	<u>Non-Specified Alternate</u>	<u>UNIT PRICE</u>	<u>QTY</u>	<u>EXTENSION</u>	<u>Non-Specified Alternate</u>	
10	 <p>REPLAY® MOBILE OPEN BOOK NOOK BASE CABINET WITH 1" ADJUSTABLE SHELF 36" WIDTH, 16" DEPTH, 36" HEIGHT, FINISHED BOTH ENDS FULLY ASSEMBLED (CASTERS INSTALLED ONSITE BY OTHERS). BULK PACKAGING. 109 LBS.</p> <p>COLORS: TOP - WILSONART CUSTOM REGIMENTAL RED WITH BLACK EDGE BANDING CASEBODY - BLACK HPL WITH BLACK EDGE BANDING.</p>		\$	663.25	36	\$23,877.00	

<b>KEY:</b>
Lowest bid on desired product
Alternate spec & bid
Recommended vendor

**Bid Seven  
School Specialty**

<u>ITEM</u>		<u>DESCRIPTION</u>	<u>Non-Specified Alternate</u>	<u>UNIT PRICE</u>	<u>QTY</u>	<u>EXTENSION</u>	<u>Non-Specified Alternate</u>
11		<p>QUOTE FOR SPECIAL CABINET CD1000 CUSTOM MOBILE CABINET WITH SHELF 48"W X 36"H X 18"D CASTERS FULLY ASSEMBLED (CASTERS INSTALLED ONSITE BY OTHERS) BULK PACKAGING. 113 LBS.</p> <p>COLORS: TOP - WILSONART CUSTOM REGIMENTAL RED WITH BLACK EDGE BANDING CASEBODY - BLACK HPL WITH BLACK EDGE BANDING.</p>		\$ 724.02	45	\$32,580.90	

<u>ITEM</u>		<u>DESCRIPTION</u>	<u>Non-Specified Alternate</u>	<u>UNIT PRICE</u>	<u>QTY</u>	<u>EXTENSION</u>	<u>Non-Specified Alternate</u>
12		<p>SEED ROCKER FRAME- 18"</p> <p>COLOR: WILSONART CUSTOM REGIMENTAL RED SHELL PLATINUM FRAME</p>		\$ 121.94	36	\$4,389.84	

<u>ITEM</u>		<u>DESCRIPTION</u>	<u>Non-Specified Alternate</u>	<u>UNIT PRICE</u>	<u>QTY</u>	<u>EXTENSION</u>	<u>Non-Specified Alternate</u>
13		<p>C-TABLE 27" FIXED HEIGHT 18" WORKSURFACE 73P EDGE</p> <p>COLOR: LAM - PRESSED LINEN 4991-38 EDGE - BLUE GREY BASE - BLACK</p>		\$ 312.13	18	\$5,618.34	

<u>ITEM</u>		<u>DESCRIPTION</u>	<u>Non-Specified Alternate</u>	<u>UNIT PRICE</u>	<u>QTY</u>	<u>EXTENSION</u>	<u>Non-Specified Alternate</u>
-------------	--	--------------------	--------------------------------	-------------------	------------	------------------	--------------------------------

<b>KEY:</b>
Lowest bid on desired product
Alternate spec & bid
Recommended vendor

**Bid Seven**  
**School Specialty**

14		<p>C-TABLE MAX 29" FIXED HEIGHT ROUND WITH CURVE TOP 24" WORKSURFACE 73P EDGE</p> <p>COLOR: LAM - PRESSED LINEN 4991-38 EDGE - BLUE GREY BASE - BLACK</p>		\$ 334.57	20	\$6,691.40	
----	---	---	--	-----------	----	------------	--

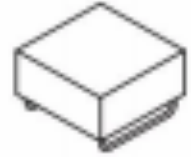
<u>ITEM</u>		<u>DESCRIPTION</u>	<u>Non-Specified Alternate</u>	<u>UNIT PRICE</u>	<u>QTY</u>	<u>EXTENSION</u>	<u>Non-Specified Alternate</u>
15		<p>HUB LAMINATE TABLE 26" X 26" GANGING-WITH (2) GANGERS ASSEMBLIES SHIPPED PER UNIT BLACK NYSON GLIDES</p> <p>COLOR: BASE FINISH - BLACK TOP LAM - PRESSED LINEN 4991-38 SIDE LAM - PRESSED LINEN 4991-38 BLACK POWER MODULE</p>		\$ 1,045.19	4	\$4,180.76	

<u>ITEM</u>		<u>DESCRIPTION</u>	<u>Non-Specified Alternate</u>	<u>UNIT PRICE</u>	<u>QTY</u>	<u>EXTENSION</u>	<u>Non-Specified Alternate</u>
16		<p>HUB ARMLESS LOUNGE, CONTRAST, 26" X 78" GANGING- WITH GANGERS (2) GANGING ASSEMBLIES SHIPPED PER UNIT NO PRIVACY SCREEN NO MOISTURE BARRIER BLACK NYLON GLIDES</p> <p>COLOR: BACK FABRIC- ARC COM SPINNAKER CHILI PEPPER #863027 SEAT/SIDE FABRIC- ARC COM EMPRESS SMOKE #23AC61882 BASE AND SEAT BACK UPRIGHT FINISH- BLACK</p>		\$ 2,563.32	8	\$20,506.56	

<u>ITEM</u>		<u>DESCRIPTION</u>	<u>Non-Specified Alternate</u>	<u>UNIT PRICE</u>	<u>QTY</u>	<u>EXTENSION</u>	<u>Non-Specified Alternate</u>
-------------	--	--------------------	--------------------------------	-------------------	------------	------------------	--------------------------------



<b>KEY:</b>
Lowest bid on desired product
Alternate spec & bid
Recommended vendor

			<b>Bid Seven</b>			
			<b>School Specialty</b>			
17		IGNITION TASK STOOL PNEU ADJ FOOTREST BACK: HEIGHT ADJ ARM: HEIGHT AND WIDTH ADJ CASTER: SOFT BACK: MESH BACK FABRIC: GRADE: III UPHOLSTERY FABRIC SELECTION: MOXIE--BASALT PAINT: FRAME: BLACK BASETYPE: BASE: STANDARD BASE COLOR: MOXIE - BASALT PAINT: FRAME: BLACK	\$	477.07	48	\$22,899.36

<b>ITEM</b>		<b>DESCRIPTION</b>	<b>Non-Specified Alternate</b>	<b>UNIT PRICE</b>	<b>QTY</b>	<b>EXTENSION</b>	<b>Non-Specified Alternate</b>
18		LYRA LOUNGE CHAIR UPH BACK SLED BASE CONTRAST 29"W X 29"D  NO MOISTURE BARRIER BLACK NYLON GLIDES BLACK BASE FINISH  COLOR: OUTER SHELL – ARC COM SPINNAKER CHILI PEPPER #863027 BACK CUSHION – ARC COM EMPRESS SMOKE #23AC61882 SEAT CUSHION – ARC COM EMPRESS SMOKE #23AC61882 INNER ARM CUSHION – ARC COM SPINNAKER CHILI PEPPER #863027		\$ 2,038.03	16	\$32,608.48	

<b>ITEM</b>		<b>DESCRIPTION</b>	<b>Non-Specified Alternate</b>	<b>UNIT PRICE</b>	<b>QTY</b>	<b>EXTENSION</b>	<b>Non-Specified Alternate</b>
19		HIGH RISE/SILVERADO ROUND OTTOMAN 18" X 18" CASTERS WRAP COLOR: DESIGNTEX WEND HEAT		\$ 260.12	16	\$4,161.92	

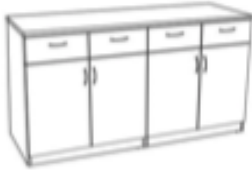
<b>KEY:</b>
Lowest bid on desired product
Alternate spec & bid
Recommended vendor

			<b>Bid Seven</b>				
			<b>School Specialty</b>				
<u>ITEM</u>	<u>DESCRIPTION</u>	<u>Non-Specified Alternate</u>	<u>UNIT PRICE</u>	<u>QTY</u>	<u>EXTENSION</u>	<u>Non-Specified Alternate</u>	
20	 <p>HYPERWORK 144" X 48" BOAT SHAPED CONFERENCE TABLE CUSTOMER 42" HEIGHT OPTIONAL BOX BASES ADD (4) COVE POWER UNITS- EACH WITH 2 POWER/2USB CENTERED AND EQUALLY SPACED COLOR: POWER COVE - SILVER LAMINATE- SHORELINE</p>		\$ 3,690.68	4	\$14,762.72		
21	 <p>BUFFET CREDENZA 4 DRAWER TWO STORAGE COMPARTMENTS WITH ONE ADJUSTABLE SHELF EACH BEHIND FOUR DOORS 36" BUFFET HEIGHT 63.5" X 24" X 36" COLOR: SPECIFY LAM - SHORELINE SPECIFY PULLS- TBAR NICKLE</p>		\$ 1,500.11	4	\$6,000.44		
22	 <p>CULINARY TABLE 60W X 30D X 35H **MODIFIED TO HAVE EM-9A CENTER TABLE BRACING KIT** **BAR IS NOT ALONG THE BACK, IT IS BEING MOVED/MODIFIED TO THE CENTER***</p>		\$ 723.62	6	\$4,341.72		
23	 <p>WORK TABLE CASTER KIT, SET OF 4</p>		\$ 81.73	6	\$490.38		

<b>KEY:</b>
Lowest bid on desired product
Alternate spec & bid
Recommended vendor

**Bid Seven  
School Specialty**

<u>ITEM</u>		<u>DESCRIPTION</u>	<u>Non-Specified Alternate</u>	<u>UNIT PRICE</u>	<u>QTY</u>	<u>EXTENSION</u>	<u>Non-Specified Alternate</u>
24		NPS® 18"-25" HEIGHT ADJUSTABLE DESIGNER STOOL COLOR: PERSIAN BLUE/BLACK		\$ 89.65	190	\$17,033.50	

<u>ITEM</u>		<u>DESCRIPTION</u>	<u>Non-Specified Alternate</u>	<u>UNIT PRICE</u>	<u>QTY</u>	<u>EXTENSION</u>	<u>Non-Specified Alternate</u>
25		NUCLEUSGUEST MULTI-PURPOSE CHAIR FOUR LEG STACKING FRAME ARM: FIXED ARM ALL SURFACE CASTER BACK: STRETCH BLACK FABRIC GRADE: III UPHOLSTERY FABRIC ELECTION: MOXIE--BASALT FRAME: BLACK COLOR: MOXIE -BASALT PAINT: FRAME: BLACK		\$ 321.57	8	\$2,572.56	

<u>ITEM</u>		<u>DESCRIPTION</u>	<u>Non-Specified Alternate</u>	<u>UNIT PRICE</u>	<u>QTY</u>	<u>EXTENSION</u>	<u>Non-Specified Alternate</u>
26		10500 SERIES 60W X 30D X 29-1/2H DBL PED DSK 3/2 RECT TOP LAMINATE: GRD L1 STANDARD LAMINATES COLOR: SHAKER CHERRY		\$ 799.87	4	\$3,199.48	

<u>ITEM</u>		<u>DESCRIPTION</u>	<u>Non-Specified Alternate</u>	<u>UNIT PRICE</u>	<u>QTY</u>	<u>EXTENSION</u>	<u>Non-Specified Alternate</u>
-------------	--	--------------------	--------------------------------	-------------------	------------	------------------	--------------------------------

<b>KEY:</b>
Lowest bid on desired product
Alternate spec & bid
Recommended vendor

**Bid Seven**

**School Specialty**

27		PRESIDE 20W X 72D X 36H HOSPITALITY CREDENZA LAMTOP: GR L1 STANDARD LAMINATES EDGE: SHAKER LAMCHASSIS: GR L1 STANDARD LAMINATES PULL: LOOP SATIN NICKEL CUTOUT: NO CUTOUT COLOR: SHAKER CHERRY		\$ 1,518.73	5	\$7,593.65	
----	---	---	--	-------------	---	------------	--

Total \$1,006,366.48  
 12% Discount \$885,602.50



<b>KEY:</b>
Lowest bid on desired product
Alternate spec & bid
Recommended vendor

			Bid Eight			Bid Nine		
			Texas Furniture Source			Weaver Manufacturing		
5		NSL FURNITURE PRODUCT TIDE FLIP TABLE 30" X 66" TIDE W/TUBULAR TBASE 29" FIXED HEIGHT HANDLE RELEASE AND INSERTS CASTERS UNASSEMBLED BULK PACKAGING. CLASS 70. 80 LBS. COLORS: DOVE GREY HPL TOP WITH BLACK BEVELED ARMOR EDGE. BLACK LEGS.	N/B	140		Weaver Manufacturing MHTBI2103150 4A	\$ 639.65	140

ITEM		DESCRIPTION	UNIT PRICE	QTY	EXTENSION	Non-Specified Alternate	UNIT PRICE	QTY
6		IGNITION WK MID-BCK PNEU SWIVEL TILT BACK: HEIGHT ADJ ARM: HEIGHT AND WIDTH ADJ CASTER: SOFT BACK: MESH BACK FABRIC: GRADE: III UPHOLSTERY FABRIC SELECTION: MOXIE COLOR: CARBON BASALT BASETYPE: STANDARD BASE COLOR: CARBON/BASALT PAINT: FRAME: BLACK	\$ 323.37	45	\$14,551.65		N/B	45

ITEM		DESCRIPTION	UNIT PRICE	QTY	EXTENSION	Non-Specified Alternate	UNIT PRICE	QTY
7		POWER TOWER  COLOR: PLATINUM	N/B	70		Weaver Manufacturing MHHDW21031 510A	\$ 628.55	70

ITEM		DESCRIPTION	UNIT PRICE	QTY	EXTENSION	Non-Specified Alternate	UNIT PRICE	QTY
------	--	-------------	------------	-----	-----------	-------------------------	------------	-----

<b>KEY:</b>
Lowest bid on desired product
Alternate spec & bid
Recommended vendor

**Bid Eight**  
**Texas Furniture Source**

**Bid Nine**  
**Weaver Manufacturing**

8		NSL FURNITURE PRODUCT ELEVATE 24" X 28.5" PLYMOUTH STUDENT DESK ADJUSTABLE HEIGHT PNEUMATIC BASE DUAL WHEEL SOFT TREAD LOCKING CASTERS & GRAND HANK GLIDES 27.94"-42.94" OVERALL ADJUSTABLE HEIGHT 1 BACKPACK HOOK UNASSEMBLED PACKAGING - BULK, 55 LBS.	N/B	400		Weaver Manufacturing MHTBI2103150 5A	\$ 443.69	400
		COLORS: TOP - WILSONART MYSTIQUE NIGHT 4760-60 BLACK BEVELED LOTZ ARMOR EDGE BLACK FRAME FINISH						

ITEM		DESCRIPTION	UNIT PRICE	QTY	EXTENSION	Non-Specified Alternate	UNIT PRICE	QTY
9		HIGH RISE/SILVERADO ROUND OTTOMAN 18" X 18" CASTERS WRAP COLORS: WRAP AROUND OTTOMAN - ARC COM HIGH RISE PRIMARY #1 TOP - ARC COM SILVERADO 2 STEEL #41	\$ 286.00	524	\$149,864.00	Weaver Manufacturing MHOTO210315 06B	\$ 329.35	524

ITEM		DESCRIPTION	UNIT PRICE	QTY	EXTENSION	Non-Specified Alternate	UNIT PRICE	QTY
10		REPLAY® MOBILE OPEN BOOK NOOK BASE CABINET WITH 1" ADJUSTABLE SHELF 36" WIDTH, 16" DEPTH, 36" HEIGHT, FINISHED BOTH ENDS FULLY ASSEMBLED (CASTERS INSTALLED ONSITE BY OTHERS). BULK PACKAGING. 109 LBS. COLORS: TOP - WILSONART CUSTOM REGIMENTAL RED WITH BLACK EDGE BANDING CASEBODY - BLACK HPL WITH BLACK EDGE BANDING.	N/B	36		Weaver Manufacturing MHSHL210315 07A	\$ 1,403.11	36

<b>KEY:</b>
Lowest bid on desired product
Alternate spec & bid
Recommended vendor

**Bid Eight**  
**Texas Furniture Source**

**Bid Nine**  
**Weaver Manufacturing**

ITEM		DESCRIPTION	UNIT PRICE	QTY	EXTENSION	Non-Specified Alternate	UNIT PRICE	QTY
11		<p>QUOTE FOR SPECIAL CABINET CD1000 CUSTOM MOBILE CABINET WITH SHELF 48"W X 36"H X 18"D CASTERS FULLY ASSEMBLED (CASTERS INSTALLED ONSITE BY OTHERS) BULK PACKAGING. 113 LBS.</p> <p>COLORS: TOP - WILSONART CUSTOM REGIMENTAL RED WITH BLACK EDGE BANDING CASEBODY - BLACK HPL WITH BLACK EDGE BANDING.</p>	N/B	45		Weaver Manufacturing MHDKS210315 11A	\$ 1,102.15	45

ITEM		DESCRIPTION	UNIT PRICE	QTY	EXTENSION	Non-Specified Alternate	UNIT PRICE	QTY
12		<p>SEED ROCKER FRAME- 18"</p> <p>COLOR: WILSONART CUSTOM REGIMENTAL RED SHELL PLATINUM FRAME</p>	N/B	36			N/B	36

ITEM		DESCRIPTION	UNIT PRICE	QTY	EXTENSION	Non-Specified Alternate	UNIT PRICE	QTY
13		<p>C-TABLE 27" FIXED HEIGHT 18" WORKSURFACE 73P EDGE</p> <p>COLOR: LAM - PRESSED LINEN 4991-38 EDGE - BLUE GREY BASE - BLACK</p>	N/B	18			N/B	18

ITEM		DESCRIPTION	UNIT PRICE	QTY	EXTENSION	Non-Specified Alternate	UNIT PRICE	QTY
------	--	-------------	------------	-----	-----------	-------------------------	------------	-----

<b>KEY:</b>
Lowest bid on desired product
Alternate spec & bid
Recommended vendor

**Bid Eight**  
**Texas Furniture Source**

**Bid Nine**  
**Weaver Manufacturing**

14		<p>C-TABLE MAX 29" FIXED HEIGHT ROUND WITH CURVE TOP 24" WORKSURFACE 73P EDGE</p> <p>COLOR: LAM - PRESSED LINEN 4991-38 EDGE - BLUE GREY BASE - BLACK</p>	N/B	20			N/B	20
----	---	---	-----	----	--	--	-----	----

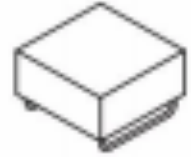
<u>ITEM</u>		<u>DESCRIPTION</u>	<u>UNIT PRICE</u>	<u>QTY</u>	<u>EXTENSION</u>	<u>Non-Specified Alternate</u>	<u>UNIT PRICE</u>	<u>QTY</u>
15		<p>HUB LAMINATE TABLE 26" X 26" GANGING-WITH (2) GANGERS ASSEMBLIES SHIPPED PER UNIT BLACK NYSON GLIDES</p> <p>COLOR: BASE FINISH - BLACK TOP LAM - PRESSED LINEN 4991-38 SIDE LAM - PRESSED LINEN 4991-38 BLACK POWER MODULE</p>	N/B	4			N/B	4

<u>ITEM</u>		<u>DESCRIPTION</u>	<u>UNIT PRICE</u>	<u>QTY</u>	<u>EXTENSION</u>	<u>Non-Specified Alternate</u>	<u>UNIT PRICE</u>	<u>QTY</u>
16		<p>HUB ARMLESS LOUNGE, CONTRAST, 26" X 78" GANGING- WITH GANGERS (2) GANGING ASSEMBLIES SHIPPED PER UNIT NO PRIVACY SCREEN NO MOISTURE BARRIER BLACK NYLON GLIDES</p> <p>COLOR: BACK FABRIC- ARC COM SPINNAKER CHILI PEPPER #863027 SEAT/SIDE FABRIC- ARC COM EMPRESS SMOKE #23AC61882 BASE AND SEAT BACK UPRIGHT FINISH- BLACK</p>	N/B	8			N/B	8

<u>ITEM</u>		<u>DESCRIPTION</u>	<u>UNIT PRICE</u>	<u>QTY</u>	<u>EXTENSION</u>	<u>Non-Specified Alternate</u>	<u>UNIT PRICE</u>	<u>QTY</u>
-------------	--	--------------------	-------------------	------------	------------------	--------------------------------	-------------------	------------



<b>KEY:</b>
Lowest bid on desired product
Alternate spec & bid
Recommended vendor

		<b>Bid Eight</b>			<b>Bid Nine</b>		
		<b>Texas Furniture Source</b>			<b>Weaver Manufacturing</b>		
17		IGNITION TASK STOOL PNEU ADJ FOOTREST BACK: HEIGHT ADJ ARM: HEIGHT AND WIDTH ADJ CASTER: SOFT BACK: MESH BACK FABRIC: GRADE: III UPHOLSTERY FABRIC SELECTION: MOXIE--BASALT PAINT: FRAME: BLACK BASETYPE: BASE: STANDARD BASE COLOR: MOXIE - BASALT PAINT: FRAME: BLACK	\$ 341.95	48	\$16,413.60	N/B	48

<b>ITEM</b>		<b>DESCRIPTION</b>	<b>UNIT PRICE</b>	<b>QTY</b>	<b>EXTENSION</b>	<b>Non-Specified Alternate</b>	<b>UNIT PRICE</b>	<b>QTY</b>
18		LYRA LOUNGE CHAIR UPH BACK SLED BASE CONTRAST 29"W X 29"D  NO MOISTURE BARRIER BLACK NYLON GLIDES BLACK BASE FINISH COLOR: OUTER SHELL – ARC COM SPINNAKER CHILI PEPPER #863027 BACK CUSHION – ARC COM EMPRESS SMOKE #23AC61882 SEAT CUSHION – ARC COM EMPRESS SMOKE #23AC61882 INNER ARM CUSHION – ARC COM SPINNAKER CHILI PEPPER #863027	N/B	16			N/B	16

<b>ITEM</b>		<b>DESCRIPTION</b>	<b>UNIT PRICE</b>	<b>QTY</b>	<b>EXTENSION</b>	<b>Non-Specified Alternate</b>	<b>UNIT PRICE</b>	<b>QTY</b>
19		HIGH RISE/SILVERADO ROUND OTTOMAN 18" X 18" CASTERS WRAP COLOR: DESIGNTEX WEND HEAT	\$ 279.50	16	\$4,472.00	Weaver Manufacturing MHOTO210315 06B	\$ 393.05	16

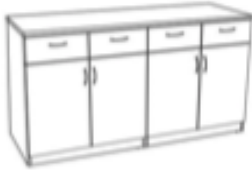
<b>KEY:</b>
Lowest bid on desired product
Alternate spec & bid
Recommended vendor

<b>Bid Eight</b>						<b>Bid Nine</b>		
<b>Texas Furniture Source</b>						<b>Weaver Manufacturing</b>		
<u>ITEM</u>	<u>DESCRIPTION</u>	<u>UNIT PRICE</u>	<u>QTY</u>	<u>EXTENSION</u>	<u>Non-Specified Alternate</u>	<u>UNIT PRICE</u>	<u>QTY</u>	
20	 <p>HYPERWORK 144" X 48" BOAT SHAPED CONFERENCE TABLE CUSTOMER 42" HEIGHT OPTIONAL BOX BASES ADD (4) COVE POWER UNITS- EACH WITH 2 POWER/2USB CENTERED AND EQUALLY SPACED COLOR: POWER COVE - SILVER LAMINATE- SHORELINE</p>	N/B	4			N/B	4	
21	 <p>BUFFET CREDENZA 4 DRAWER TWO STORAGE COMPARTMENTS WITH ONE ADJUSTABLE SHELF EACH BEHIND FOUR DOORS 36" BUFFET HEIGHT 63.5" X 24" X 36" COLOR: SPECIFY LAM - SHORELINE SPECIFY PULLS- TBAR NICKLE</p>	N/B	4			N/B	4	
22	 <p>CULINARY TABLE 60W X 30D X 35H **MODIFIED TO HAVE EM-9A CENTER TABLE BRACING KIT** **BAR IS NOT ALONG THE BACK, IT IS BEING MOVED/MODIFIED TO THE CENTER***</p>	N/B	6			N/B	6	
23	 <p>WORK TABLE CASTER KIT, SET OF 4</p>	N/B	6			N/B	6	





<b>KEY:</b>
Lowest bid on desired product
Alternate spec & bid
Recommended vendor

			<b>Bid Eight</b>			<b>Bid Nine</b>		
			<b>Texas Furniture Source</b>			<b>Weaver Manufacturing</b>		
27		PRESIDE 20W X 72D X 36H HOSPITALITY CREDENZA LAMTOP: GR L1 STANDARD LAMINATES EDGE: SHAKER LAMCHASSIS: GR L1 STANDARD LAMINATES PULL: LOOP SATIN NICKEL CUTOUT: NO CUTOUT COLOR: SHAKER CHERRY	\$ 1,073.23	5	\$5,366.15		N/B	5

<b>KEY:</b>
Lowest bid on desired product
Alternate spec & bid
Recommended vendor

ITEM		DESCRIPTION	EXTENSION
1		HIERARCHY 5-STAR STOOL WITH ARMS BLACK PLASTIC BASE SOFT CASTERS 22" - 33" COLOR: WILSONART CUSTOM REGIMENTAL RED SHELL	\$225,580.00

ITEM		DESCRIPTION	EXTENSION
2		REFLECTION WORKSTATION 30"D X 60"L TOP 36"W X 23"D CASEBODY 36" HEIGHT SHELF AND 2 DOUBLE DOORS LOCK CONNECTING MAGNETS FOR HANGOUT STOOLS (2 LOCATIONS) UNASSEMBLED BULK PACKAGING. 236 LBS COLOR: WILSONART CUSTOM REGIMENTAL RED TOP WITH BLACK BEVELED ARMOR EDGE BLACK HPL CASEBODY WITH BLACK EDGE BANDING	\$184,566.06

ITEM		DESCRIPTION	EXTENSION
3		13" SQUARE SEAT, 24" FIXED SILVER HANGOUT STOOL BP (10 LBS.) COLOR: SILVER	\$37,326.24

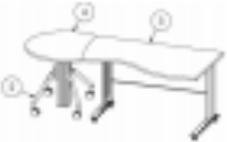
ITEM		DESCRIPTION	EXTENSION
4		TEACHER DESK COLOR: SPECIFY LAM- CONCRETE GROOVZ SPECIFY EDGE- GRAPHITE SPECIFY BASE- BLACK	\$82,773.60

ITEM		DESCRIPTION	EXTENSION
------	--	-------------	-----------

<b>KEY:</b>
Lowest bid on desired product
Alternate spec & bid
Recommended vendor

5		NSL FURNITURE PRODUCT TIDE FLIP TABLE 30" X 66" TIDE W/TUBULAR TBASE 29" FIXED HEIGHT HANDLE RELEASE AND INSERTS CASTERS UNASSEMBLED BULK PACKAGING. CLASS 70. 80 LBS.	\$89,551.00
		COLORS: DOVE GREY HPL TOP WITH BLACK BEVELED ARMOR EDGE. BLACK LEGS.	

<u>ITEM</u>		<u>DESCRIPTION</u>	<u>EXTENSION</u>
6		IGNITION WK MID-BCK PNEU SWIVEL TILT BACK: HEIGHT ADJ ARM: HEIGHT AND WIDTH ADJ CASTER: SOFT BACK: MESH BACK FABRIC: GRADE: III UPHOLSTERY FABRIC SELECTION: MOXIE COLOR: CARBON BASALT BASETYPE: STANDARD BASE	
		COLOR: CARBON/BASALT PAINT: FRAME: BLACK	

<u>ITEM</u>		<u>DESCRIPTION</u>	<u>EXTENSION</u>
7		POWER TOWER	\$43,998.50
		COLOR: PLATINUM	

<u>ITEM</u>		<u>DESCRIPTION</u>	<u>EXTENSION</u>
-------------	--	--------------------	------------------

<b>KEY:</b>
Lowest bid on desired product
Alternate spec & bid
Recommended vendor

8		NSL FURNITURE PRODUCT ELEVATE 24" X 28.5" PLYMOUTH STUDENT DESK ADJUSTABLE HEIGHT PNEUMATIC BASE DUAL WHEEL SOFT TREAD LOCKING CASTERS & GRAND HANK GLIDES 27.94"-42.94" OVERALL ADJUSTABLE HEIGHT 1 BACKPACK HOOK UNASSEMBLED PACKAGING - BULK, 55 LBS.	\$177,476.00
		COLORS: TOP - WILSONART MYSTIQUE NIGHT 4760-60 BLACK BEVELED LOTZ ARMOR EDGE BLACK FRAME FINISH	

<u>ITEM</u>		<u>DESCRIPTION</u>	<u>EXTENSION</u>
9		HIGH RISE/SILVERADO ROUND OTTOMAN 18" X 18" CASTERS WRAP COLORS: WRAP AROUND OTTOMAN - ARC COM HIGH RISE PRIMARY #1 TOP - ARC COM SILVERADO 2 STEEL #41	\$172,579.40

<u>ITEM</u>		<u>DESCRIPTION</u>	<u>EXTENSION</u>
10		REPLAY® MOBILE OPEN BOOK NOOK BASE CABINET WITH 1" ADJUSTABLE SHELF 36" WIDTH, 16" DEPTH, 36" HEIGHT, FINISHED BOTH ENDS FULLY ASSEMBLED (CASTERS INSTALLED ONSITE BY OTHERS). BULK PACKAGING. 109 LBS.	\$50,511.96
		COLORS: TOP - WILSONART CUSTOM REGIMENTAL RED WITH BLACK EDGE BANDING CASEBODY - BLACK HPL WITH BLACK EDGE BANDING.	

<b>KEY:</b>
Lowest bid on desired product
Alternate spec & bid
Recommended vendor

<u>ITEM</u>		<u>DESCRIPTION</u>	<u>EXTENSION</u>
11		<p>QUOTE FOR SPECIAL CABINET            CD1000 CUSTOM MOBILE CABINET WITH SHELF            48"W X 36"H X 18"D            CASTERS            FULLY ASSEMBLED            (CASTERS INSTALLED ONSITE BY OTHERS)            BULK PACKAGING. 113 LBS.</p> <p>COLORS: TOP - WILSONART CUSTOM REGIMENTAL RED WITH BLACK EDGE BANDING            CASEBODY - BLACK HPL WITH BLACK EDGE BANDING.</p>	\$49,596.75

<u>ITEM</u>		<u>DESCRIPTION</u>	<u>EXTENSION</u>
12		<p>SEED ROCKER FRAME- 18"</p> <p>COLOR: WILSONART CUSTOM REGIMENTAL RED SHELL            PLATINUM FRAME</p>	

<u>ITEM</u>		<u>DESCRIPTION</u>	<u>EXTENSION</u>
13		<p>C-TABLE            27" FIXED HEIGHT            18" WORKSURFACE            73P EDGE</p> <p>COLOR: LAM - PRESSED LINEN 4991-38            EDGE - BLUE GREY            BASE - BLACK</p>	

<u>ITEM</u>		<u>DESCRIPTION</u>	<u>EXTENSION</u>
-------------	--	--------------------	------------------

<b>KEY:</b>
Lowest bid on desired product
Alternate spec & bid
Recommended vendor

14		C-TABLE MAX 29" FIXED HEIGHT ROUND WITH CURVE TOP 24" WORKSURFACE 73P EDGE	
		COLOR: LAM - PRESSED LINEN 4991-38 EDGE - BLUE GREY BASE - BLACK	

<u>ITEM</u>		<u>DESCRIPTION</u>	<u>EXTENSION</u>
15		HUB LAMINATE TABLE 26" X 26" GANGING-WITH (2) GANGERS ASSEMBLIES SHIPPED PER UNIT BLACK NYSON GLIDES	
		COLOR: BASE FINISH - BLACK TOP LAM - PRESSED LINEN 4991-38 SIDE LAM - PRESSED LINEN 4991-38 BLACK POWER MODULE	

<u>ITEM</u>		<u>DESCRIPTION</u>	<u>EXTENSION</u>
16		HUB ARMLESS LOUNGE, CONTRAST, 26" X 78" GANGING- WITH GANGERS (2) GANGING ASSEMBLIES SHIPPED PER UNIT NO PRIVACY SCREEN NO MOISTURE BARRIER BLACK NYLON GLIDES	
		COLOR: BACK FABRIC- ARC COM SPINNAKER CHILI PEPPER #863027 SEAT/SIDE FABRIC- ARC COM EMPRESS SMOKE #23AC61882 BASE AND SEAT BACK UPRIGHT FINISH- BLACK	

<u>ITEM</u>		<u>DESCRIPTION</u>	<u>EXTENSION</u>
-------------	--	--------------------	------------------

<b>KEY:</b>
Lowest bid on desired product
Alternate spec & bid
Recommended vendor

17		IGNITION TASK STOOL PNEU ADJ FOOTREST BACK: HEIGHT ADJ ARM: HEIGHT AND WIDTH ADJ CASTER: SOFT BACK: MESH BACK FABRIC: GRADE: III UPHOLSTERY FABRIC SELECTION: MOXIE--BASALT PAINT: FRAME: BLACK BASETYPE: BASE: STANDARD BASE COLOR: MOXIE - BASALT PAINT: FRAME: BLACK	
----	---	--	--

ITEM		DESCRIPTION	EXTENSION
18		LYRA LOUNGE CHAIR UPH BACK SLED BASE CONTRAST 29"W X 29"D  NO MOISTURE BARRIER BLACK NYLON GLIDES BLACK BASE FINISH  COLOR: OUTER SHELL – ARC COM SPINNAKER CHILI PEPPER #863027 BACK CUSHION – ARC COM EMPRESS SMOKE #23AC61882 SEAT CUSHION – ARC COM EMPRESS SMOKE #23AC61882 INNER ARM CUSHION – ARC COM SPINNAKER CHILI PEPPER #863027	

ITEM		DESCRIPTION	EXTENSION
19		HIGH RISE/SILVERADO ROUND OTTOMAN 18" X 18" CASTERS WRAP COLOR: DESIGNTEX WEND HEAT	\$6,288.80

<b>KEY:</b>
Lowest bid on desired product
Alternate spec & bid
Recommended vendor

<u>ITEM</u>		<u>DESCRIPTION</u>	<u>EXTENSION</u>
20		<p>HYPERWORK 144" X 48" BOAT SHAPED CONFERENCE TABLE CUSTOMER 42" HEIGHT            OPTIONAL BOX BASES            ADD (4) COVE POWER UNITS- EACH WITH 2 POWER/2USB CENTERED AND EQUALLY SPACED            COLOR: POWER COVE - SILVER            LAMINATE- SHORELINE</p>	

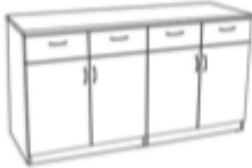
<u>ITEM</u>		<u>DESCRIPTION</u>	<u>EXTENSION</u>
21		<p>BUFFET CREDENZA            4 DRAWER            TWO STORAGE COMPARTMENTS WITH ONE ADJUSTABLE SHELF EACH BEHIND FOUR DOORS            36" BUFFET HEIGHT            63.5" X 24" X 36"            COLOR: SPECIFY LAM - SHORELINE            SPECIFY PULLS- TBAR NICKLE</p>	

<u>ITEM</u>		<u>DESCRIPTION</u>	<u>EXTENSION</u>
22		<p>CULINARY TABLE            60W X 30D X 35H            **MODIFIED TO HAVE EM-9A CENTER TABLE BRACING KIT**            **BAR IS NOT ALONG THE BACK, IT IS BEING MOVED/MODIFIED TO THE CENTER***</p>	

<u>ITEM</u>		<u>DESCRIPTION</u>	<u>EXTENSION</u>
23		WORK TABLE CASTER KIT, SET OF 4	

<b>KEY:</b>
Lowest bid on desired product
Alternate spec & bid
Recommended vendor

<u>ITEM</u>		<u>DESCRIPTION</u>	<u>EXTENSION</u>
24		NPS® 18"-25" HEIGHT ADJUSTABLE DESIGNER STOOL COLOR: PERSIAN BLUE/BLACK	\$33,094.20

<u>ITEM</u>		<u>DESCRIPTION</u>	<u>EXTENSION</u>
25		NUCLEUSGUEST MULTI-PURPOSE CHAIR FOUR LEG STACKING FRAME ARM: FIXED ARM ALL SURFACE CASTER BACK: STRETCH BLACK FABRIC GRADE: III UPHOLSTERY FABRIC ELECTION: MOXIE--BASALT FRAME: BLACK COLOR: MOXIE -BASALT PAINT: FRAME: BLACK	

<u>ITEM</u>		<u>DESCRIPTION</u>	<u>EXTENSION</u>
26		10500 SERIES 60W X 30D X 29-1/2H DBL PED DSK 3/2 RECT TOP LAMINATE: GRD L1 STANDARD LAMINATES COLOR: SHAKER CHERRY	

<u>ITEM</u>		<u>DESCRIPTION</u>	<u>EXTENSION</u>

<b>KEY:</b>
Lowest bid on desired product
Alternate spec & bid
Recommended vendor

27		<p>PRESIDE 20W X 72D X 36H HOSPITALITY          CREDENZA          LAMTOP: GR L1 STANDARD LAMINATES          EDGE: SHAKER          LAMCHASSIS: GR L1 STANDARD LAMINATES          PULL: LOOP SATIN NICKEL          CUTOUT: NO CUTOUT          COLOR: SHAKER CHERRY</p>	
----	---	--	--



**Midlothian I.S.D. School Board Agenda Item Detail  
L.A. Mills Administrative Complex Boardroom**

<b>Board Meeting Date:</b>	<b>April 19, 2021</b>									
<b>Item:</b>	<b>Consider Purchase of FF&amp;E Technology Items for Heritage Phase #2</b>									
<b>Supporting Document(s):</b>	Electronic: Yes <input checked="" type="checkbox"/> No <input type="checkbox"/>	Hard Copy: Yes <input type="checkbox"/> No <input checked="" type="checkbox"/>								
<b>Background Information:</b>	<p>We are continuing with the plan for outfitting the campus with the necessary furniture, fixtures, and equipment. The following list of technology items are needed to support campus operations.</p> <ul style="list-style-type: none"> <li>• Network switches (24) and wireless access points (90) needed for network connections throughout the new additions.</li> <li>• Promethean Boards (49) for classrooms and collaboration areas.</li> </ul> <p>Both items listed here are based on pricing submitted in prior RFPs.</p> <ul style="list-style-type: none"> <li>• RFP#2021-009 Network Services &amp; Equipment</li> <li>• RFP#1819-013 Secondary Campus AV</li> </ul> <table border="1"> <thead> <tr> <th>Item</th> <th>Cost</th> </tr> </thead> <tbody> <tr> <td>Netsync (Network Services &amp; Equipment)</td> <td>\$297,983.20</td> </tr> <tr> <td>CDWG (Promethean Boards)</td> <td>\$220,107.82</td> </tr> <tr> <td><b>TOTAL</b></td> <td><b>\$518,091.02</b></td> </tr> </tbody> </table>		Item	Cost	Netsync (Network Services & Equipment)	\$297,983.20	CDWG (Promethean Boards)	\$220,107.82	<b>TOTAL</b>	<b>\$518,091.02</b>
Item	Cost									
Netsync (Network Services & Equipment)	\$297,983.20									
CDWG (Promethean Boards)	\$220,107.82									
<b>TOTAL</b>	<b>\$518,091.02</b>									
<b>Fiscal Impact/Budget Function Code:</b>	2016 Bond Funds (FF&E for Heritage Phase #2)									
<b>Policy:</b>	NA									
<b>District Goal:</b>	Maintain sound fiscal management									
<b>Administration Recommended Option:</b>	It is the administration's recommendation to approve the bids as presented.									
<b>Motion:</b>	A motion might be, "I move to approve the proposals as presented."									
<b>Presenter:</b>	Leslie Garakani									

**Midlothian I.S.D. School Board Agenda Item Detail**  
**L.A. Mills Administrative Complex Boardroom**

<b>Board Meeting Date:</b>	<b>April 19, 2021</b>	
<b>Item:</b>	<b>M*Powered 1:1 and Chromebook Pilot Update</b>	
<b>Supporting Document(s):</b>	Electronic: Yes <input checked="" type="checkbox"/> No <input type="checkbox"/>	Hard Copy: Yes <input type="checkbox"/> No <input checked="" type="checkbox"/>
<b>Background Information:</b>	This will be a <a href="#">presentation</a> on the M*Powered 1:1 program and the Chromebook pilot currently being conducted.	
<b>Fiscal Impact/Budget Function Code:</b>	N/A	
<b>Policy:</b>	N/A	
<b>District Goal:</b>	GOAL 5: Provide support and resources to cultivate customization and personalization through blended learning opportunities.	
<b>Administration Recommended Option:</b>	N/A	
<b>Motion:</b>	Presentation only	
<b>Presenter:</b>	Shelle Blaylock, Leslie Garakani, Becki Krsnak	



# **MISD School Board Meeting**

## ***Department of Learning Update: MPowered***

---

April 19, 2021

# Texas Technology Standards

Following are Technology Standards for students:

- [Prekindergarten Guidelines](#)
- [Technology Applications Texas Essential Knowledge and Skills \(TEKS\), Grades K-12, Texas Administrative Code \(TAC\) Chapter 126](#)

Following are Technology Standards for teachers:

- [Technology Applications Standards, I-V \(All Beginning Teachers and Recommended for Current Teachers\) and VI-XI](#)(PDF)
- [Master Technology Teacher Standards](#)(PDF)

Following are Library Standards:

- [School Librarian Certificate](#)
- [School Library Standards and Guidelines](#)



# ELAR TEKS - **NOT** tested on STAAR (3rd Grade & English I)

- 3.1 **Communicate** ideas effectively through speaking and discussion
- 3.9(F) Recognize characteristics of **multimodal and digital texts**
- 3.10 The student analyzes and applies author's crafts purposefully in order to **develop his or her own products and performances.**
- 3.13 Use research skills to plan and present in **write, oral, or multimodal formats**
- E2.1 **Communicate** ideas effectively through speaking and discussion
- E2.7(F) Analyze characteristics of **multimodal and digital texts**
- E2.8 The student analyzes and applies author's crafts purposefully in order to **develop his or her own products and performances.**
- E2.11 Use research skills to plan and present in **write, oral, or multimodal formats**

Several ELAR TEKS start with: Explain, Discuss, Analyze, Reflect, Interact, Describe



# Math TEKS - **NOT** on STAAR (4th Grade & Algebra I)

- 4.1 The student uses mathematical processes to acquire and **demonstrate mathematical understanding**.
- 4.7(A) **Illustrate** the measure of an angle as the part of a circle...
- 4.7(B) **Illustrate** degrees as the units used to measure and angle...
- 4.5(C) **Use models** to determine the formulas for the perimeter of a rectangle
- 4.10(D) **Describe** how to allocate weekly allowance among spending, saving,...
- A1 The student uses mathematical processes to acquire and **demonstrate mathematical understanding**.
- A2. **Applies** the mathematical process standards when using properties of linear functions to write and represent in multiple ways, **with and without technology**...
- A.5 **Applies** the mathematical process standards to solve, **with and without technology**, linear equations and evaluate the *reasonableness of their solutions*.

Several TEKS start with: Communicate, Create, Display, Explain, Analyze, Apply



# MISD Learner Experience

Communicate

Describe

Interact

Create/Illustrate

Display

Analyze

Apply

Research



Stage	Final Descriptions
Engage	Engagement captivates student interests through memorable experiences to inspire an investment in learning.
Inquire	Inquiry encourages and inspires curiosity which empowers individuals to question and wonder without boundaries.
Explore	Exploration promotes risk-taking, investigation, and research of the unknown.
Collaborate	Collaboration provides opportunities to partner with others to communicate, problem-solve, and exchange ideas.
Design/Create	Designing/creating fosters innovation, application, and construction for authentic experiences.
Reflect/Connect	Reflection and connection nurture a culture of evaluation and application to bridge learning and learning experiences.





## Students are asked to collect and analyze data

**Analyze** is a keyword found in multiple TEKS for all 4 core contents.

Chart

Trends

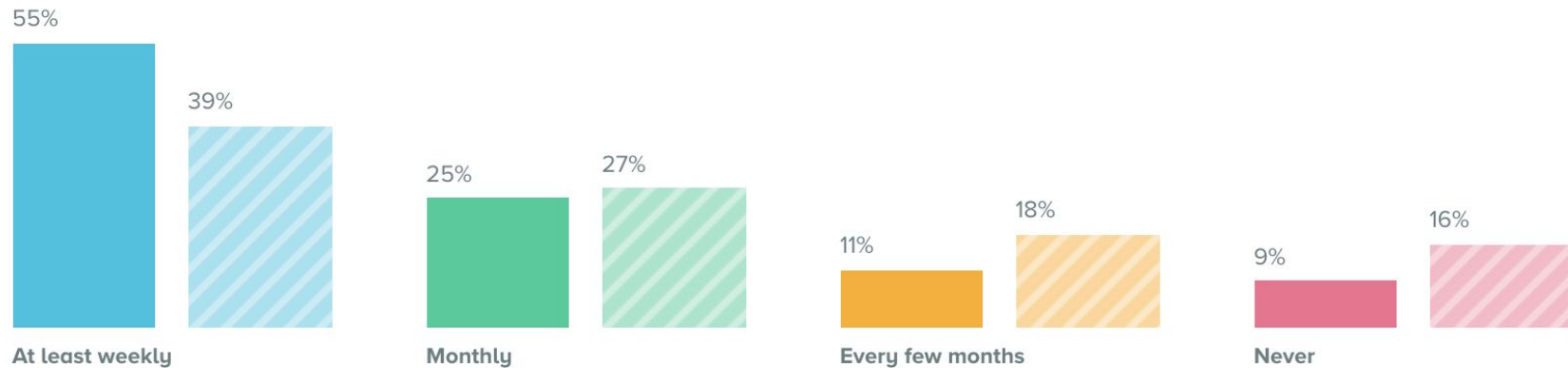

COMPARE



Current  
Solids



Texas  
Stripes

2020  BrightBytes®



# Students are asked to conduct **research**

ELAR TEKS: Use **research** skills to plan and present in **write, oral, or multimodal formats**

Chart

Trends

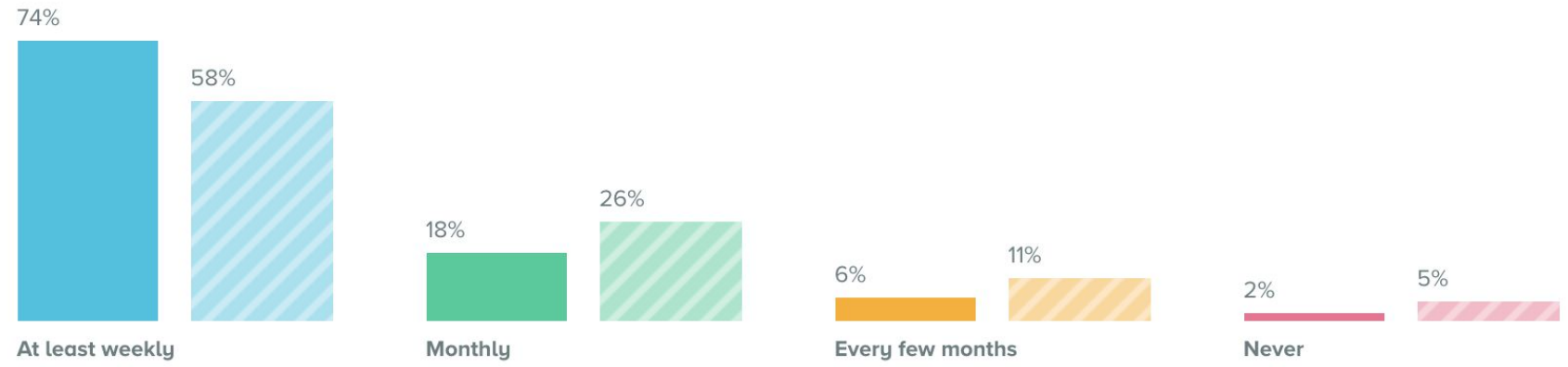

COMPARE

Current Solids

Texas Stripes

2020 BrightBytes®

# Students are asked to **create** models, simulations, or animations using technology

Chart

Trends

ELAR TEKS: The student analyzes and applies author's crafts purposefully in order to **develop his or her own products and performances.**

Math TEKS: **Create, Illustrate, Design**

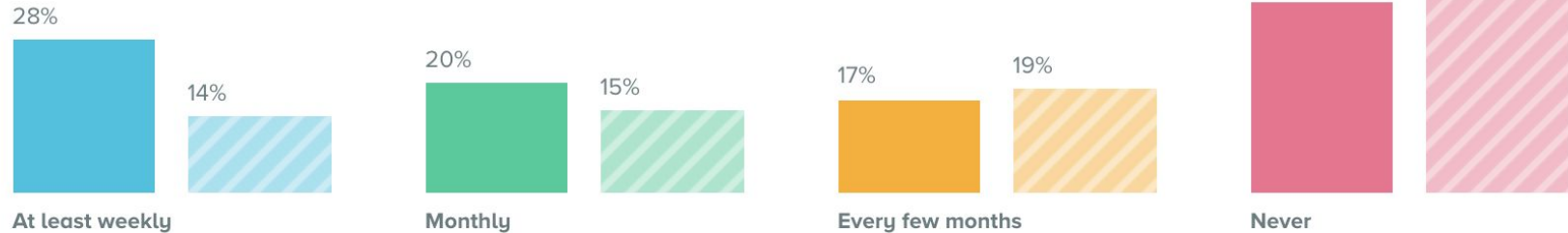

COMPARE

Current Solids

Texas Stripes

2020 BrightBytes®

 Students are asked to use computers to **solve problems** efficiently

Chart

Trends

MATH TEKS: A1 The student uses mathematical processes to acquire and **demonstrate mathematical understanding**.  
Applies - with and without technology

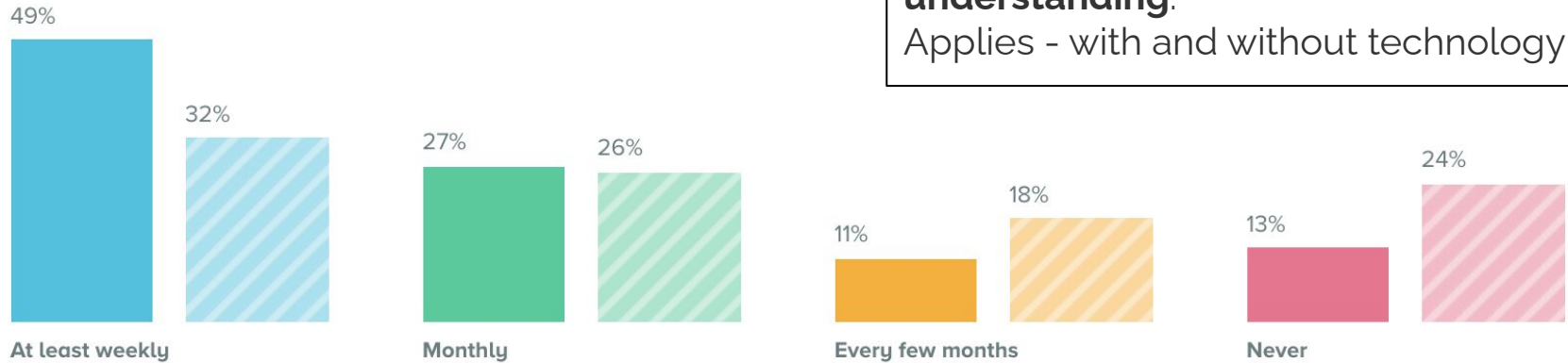

 COMPARE

 Current Solids

 Texas Stripes

2020  BrightBytes®

# Device Pilot Review and Update

Provide staff and students the opportunity to use Chromebook devices in various environments to determine viability for 1:1 device replacement.

- One Chromebook cart for each elementary school and two for each secondary school.
- A Chromebook has been provided to teachers that have expressed an interest in evaluating the device.
- A Pre-Evaluation survey was sent to teachers in the pilot group to obtain their initial thoughts and experiences.
- A Post-Evaluation survey was sent to teachers in the pilot group to capture any changes in their thoughts and experiences.





**Midlothian I.S.D. School Board Agenda Item Detail**  
**L.A. Mills Administrative Complex Boardroom**

<b>Board Meeting Date:</b>	<b>April 19, 2021</b>	
<b>Item:</b>	<b>JROTC Update</b>	
<b>Supporting Document(s):</b>	Electronic: Yes <input checked="" type="checkbox"/> No <input type="checkbox"/>	Hard Copy: Yes <input type="checkbox"/> No <input checked="" type="checkbox"/>
<b>Background Information:</b>	<p>The Department of Learning has updated information related to JROTC programming costs, structure and program requirements. <a href="#">Presentation</a> includes factors related to implementation and recommendations for the future.</p>	
<b>Fiscal Impact/Budget Function Code:</b>	N/A	
<b>Policy:</b>	N/A	
<b>District Goal:</b>	GOAL 1: Design innovative learning environments while increasing academic rigor through aligned teaching and learning.	
<b>Administration Recommended Option:</b>	N/A	
<b>Motion:</b>	Presentation only	
<b>Presenter:</b>	Shelle Blaylock	



# JROTC Program Update

---

Shelle Blaylock,  
Senior Executive Director of Curriculum and Instruction

# Factors to Consider for Implementation

- Student Course Requests
- Limited number of JROTC Programs in US
- Low Scoring Points on Application
- Cost
- Dedicated Space Needed
- Staffing - 2 instructors certified by HQ USACC
- Desire to Provide Program to Students



# Summary of Points for Application for JROTC

Criteria	Possible Points	Projected Points Earned
Title 1	20	0
Need	20	0
Student Enrollment (56 student requests)	15	5
Willingness	15	10
School Financial Solvency	5	5
School Facilities	10	5
Fair & Equitable Distribution	15	0
	100	<b>25</b>

## CURRENT APPLICATIONS

Max JROTC Programs  
Granted:  
**1709**

Current JROTC Units:  
**1698**



# JROTC Estimated Costs

## *Start-up & Sustainment Cost FY 18/19*

### \*New Unit Start-up Cost (4 mos)

OMA	FY18
Instructor Pay (2 Inst)	34,912
Travel	2,593
Installation Support	11,770
Curriculum	4,908
JSOCC Tng (2 Inst)	3,757
Computers/Comm (incls classroom equip)	17,008
Printing/Publications	868
Demil Rifles	15,049
Insurance	864
<b>TOTAL OMA</b>	<b>91,729</b>
<b>MPA</b>	
Laundry/Alterations	7,122
Cadet Uniforms	80,938
<b>TOTAL MPA</b>	<b>88,060</b>
<b>Grand Total</b>	<b>179,789</b>

### Sustainment Cost (12 mos/150 cdt)

OMA	FY18
Instructor Pay (2 Inst)	68,993
JCLC Travel	828
Curriculum	3,028
Installation Support	5,074
Other Travel/TNG	1,818
Insurance	864
<b>TOTAL OMA</b>	<b>80,605</b>
<b>MPA</b>	
Laundry/Alterations	5,976
Cadet Uniforms	20,473
<b>TOTAL MPA</b>	<b>26,449</b>
<b>Grand Total</b>	<b>107,054</b>

\*Time difference between start of Program (June) and Fiscal Year (October); Program established in June to be up and running at the start of the School Year.



# NDCC Estimated Costs

## (1) Start-up Costs:

Instructor Salaries	\$ 40,567.00
Computer/phone/modem/internet	\$ 16,840.00
Classroom Equipment	
Insurance	\$ 856.00
Office Materials	\$ 10,413.00
Demilitarized Rifles	\$ 11,917.00
Instructor Travel	\$ 1,214.00
*Uniforms/Laundry	<u>\$ 67,979.00</u>
TOTAL	\$149,786.00

## (2) Sustainment Costs:

Instructor Salaries	\$125,836.00
Computer/phone/modem/internet	\$ 321.00
Insurance	\$ 856.00
Office Materials	\$ 5,109.00
Demilitarized Rifles	0
Instructor Travel	\$ 1,070.00
*Uniforms	<u>\$ 17,778.00</u>
TOTAL	\$150,970.00



## Options:

- ❑ Apply for JROTC traditional program
- ❑ Partner with neighboring district to allow MISD students involvement in a program for 2021-22
- ❑ Find alternative programs that can meet the desires of students seeking JROTC involvement
- ❑ Budget and prepare to implement all aspects of National Defense Cadet Corp (NDCC) program *[\*100% funded annually by MISD]*



# Recommendation

- Seek and provide alternative programs with similar components
- Pursue application submission with guidance from JROTC national and state officials (*already in process*)
  - Explore Air Force and Army
  - Continue to build interest toward JROTC
  - Plan to implement when Heritage Phase 2 opens

## Continue:

- Promoting Recruiter Visits
- Inviting Recruiters to District Events
- Tracking Military Interest
- Offering ASVAB





# Questions/Comments

---

**Midlothian I.S.D. School Board Agenda Item Detail**  
**L.A. Mills Administrative Complex Boardroom**

<b>Board Meeting Date:</b>	<b>April 19, 2021</b>	
<b>Item:</b>	<b>Proclamation 2021 IMA/Textbook Adoption:</b> <ul style="list-style-type: none"> <li>● <b>PreKindergarten Curriculum Adoption</b></li> </ul>	
<b>Supporting Document(s):</b>	Electronic: Yes	Hard Copy: No
<b>Background Information:</b>	<p>Proclamation 2021 calls for new instructional materials to be reviewed, selected, and purchased with funds provided by the state in the Instructional Materials Allotment allocation. The IMA committee members met multiple times where they attended vendor fairs/textbook preview days, evaluated current PreK Material and what our Prek needs are now, adopted a rubric to evaluate the materials, evaluated materials, and taught a minimum of one lesson from each vendor under consideration, collaborated with other PreK teachers across the district, and will recommend a list of materials best suited for our district needs to the District IMA Committee. After the past 6 months of reviewing several programs, the committee and principals have come to the recommendation of purchasing</p> <p style="text-align: center;"><a href="#">Presentation to the Board</a></p> <p><b>PreK/ECSE - \$42, 200</b></p>	
<b>Fiscal Impact/Budget Function Code:</b>	If approved as presented, the cost implications will be covered with Instructional Materials Allotment funds.	
<b>Policy:</b>	EFAA (Legal and Local)	
<b>District Goal:</b>	Design innovative learning environments while increasing academic rigor through aligned teaching and learning.	
<b>Administration Recommended Option:</b>	Approve recommendation for the new PreK/ECSE materials for PreK curriculum	
<b>Motion:</b>	This is a consent agenda item, if the item is pulled for discussion, a motion might be, "I move to approve the as submitted by the MISD administration."	
<b>Presenter:</b>	Becki Krsnak	



# PreK Adoptions

---

Becki Krsnak

# PreK Adoption Committee

**The MISD PreK/ECSE Adoption Committee is comprised of representatives from each campus, from both general education and special education.**

- Mt. Peak - Christy Warren
- Vitovsky - Brenda White
- Irvin - Elizabeth Richardson
- Baxter - Tonya Fisher
- Longbranch - Erin Kimball
- SEL Specialist - Shanna Malone
- iCoach - Lauren Benner
- Campus Administration: Karena Blackwell and Hollye Walker
- District Administration: Tanesha Yusuf, Becki Krsnak, Melissa Wolfe, Shannon Thompson, Becky Beegle



# PreK Timeline

1. November-January - Learn more about available programs from vendors
2. Jan. 12 - Identify needs, goals, and criteria to evaluate programs
3. Jan. 12-31 - Rate the materials using the TEA evaluation process
4. Feb. 2 - Review ratings and determine top two programs
5. Feb. 3-23 - Teach from top two programs and reflect
6. Feb. 23 (Scholastic) & March 2 (Frog Street)
7. March - teach from programs and complete Google Form and meeting on March 25th, April 5, and April 8 for the vote
8. April board meeting - Take recommendation to the Board
9. Present to DEIC and public review on April 20th
10. May board meeting - Board vote on recommendation



# PreK Programs Reviewed

- Savvas
- Learning Without Tears
- **Scholastic**
- Kaplan Connect4Learning
- **Frog Street**
- Quaver
- Creative Curriculum by Teaching Strategies



# Final Recommendation



SCHOLASTIC



*en español*

## Welcome to PreK On My Way!

This new comprehensive program, available in English and Spanish, invites every child to take the first steps on their learning adventure through songs, games, and books.



**Easy to  
implement**



**Flexible  
curriculum**



**High-quality and  
culturally-  
diverse literature**



**Powerful  
partnerships**



**Midlothian I.S.D. School Board Agenda Item Detail**  
**L.A. Mills Administrative Complex Boardroom**

<b>Board Meeting Date:</b>	<b>April 19, 2021</b>	
<b>Item:</b>	<b>Dual Learning Platform</b>	
<b>Supporting Document(s):</b>	Electronic: Yes <input checked="" type="checkbox"/> No <input type="checkbox"/>	Hard Copy: Yes <input type="checkbox"/> No <input checked="" type="checkbox"/>
<b>Background Information:</b>	TEA has directed districts to encourage students to return to in-person instruction, but to simultaneously and proactively plan for a virtual learning option for next year, pending legislative action. Districts will not be required to offer a virtual option; however, based on the needs of our community we must move forward with a plan that would work for our District.	
<b>Fiscal Impact/Budget Function Code:</b>	N/A	
<b>Policy:</b>	N/A	
<b>District Goal:</b>	N/A	
<b>Administration Recommended Option:</b>	Information only	
<b>Motion:</b>	Information only	
<b>Presenter:</b>	Shorr Heathcote	



# Dual Learning Platform & Virtual Learning Planning 2021-2022 Update

---

Board Presentation  
April 19, 2021

# Dual Learning Platform Past, Present, and Future

- Due to COVID 19 Pandemic, the Texas Education Agency was granted emergency permission to fund virtual learning for **2020-2021**.
- The Texas Education Agency has directed Districts to proactively plan for the virtual learning needs of the students and families in which they serve for **2021-2022** while the Legislature is in session.
- Final approval for any virtual learning in **2021-2022** will be based on Legislative Action or an extension of any emergency order given to TEA.
  - Local District virtual learning plan would need to be approved by local School Board.



# Dual Learning Platform Committee - Purpose

- **Data Collection (Fall 2020 and Spring 2021)**
  - Staff feedback in Superintendent Lunch & Learns
  - Staff feedback in District Staff Meetings and ThoughtExchange
  - Parent Feedback through Virtual Learning Survey
- **Teacher Assignments**
  - Virtual or F2F
- **Medical Exemptions due to COVID**
  - Provide opportunity for Immunocompromised students to remain in Midlothian ISD



# Dual Learning Platform Committee Members

- Over 65 committee members
- Over 30 committee meetings
- Committee Representation
  - Teachers
  - Campus Administrators
  - District/Department Administrators
  - Specialized Learning
  - CTE
- Sub-Committees
  - Elementary
  - Secondary
    - Middle School
    - High School
  - Specialized Learning
  - CTE



# Parent Virtual Learning Interest

If legislative action is taken to allow virtual programs, would you consider enrolling your child in a full-time, online Midlothian ISD Virtual Learning platform, as described for the 2021-2022 school year?

2,875 responses

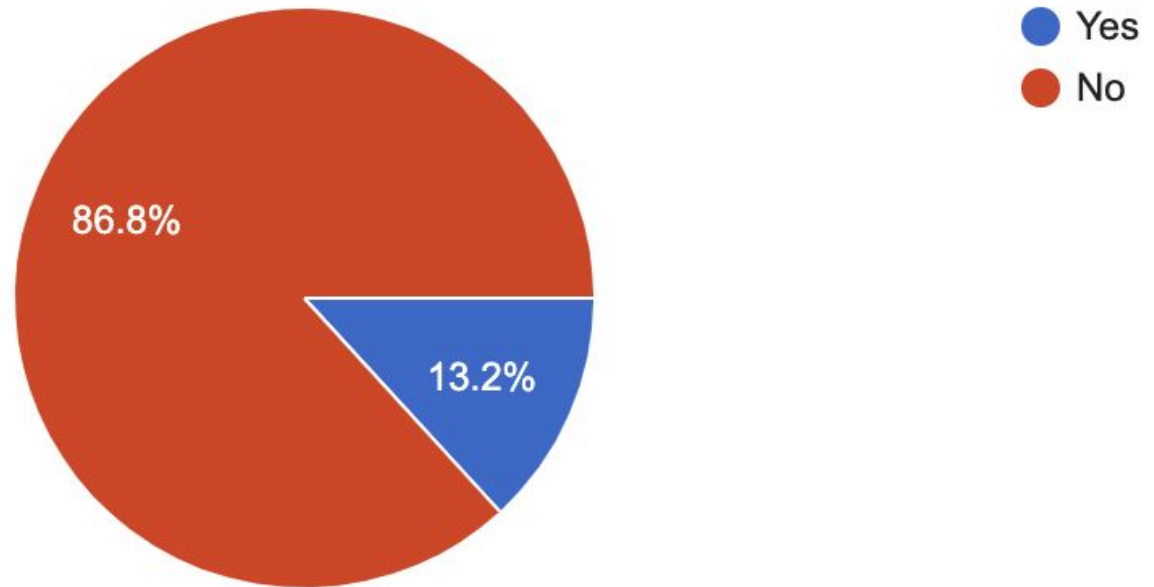

**\* ~29% of parents responded (2,875 responding out of 9,942)**





# Elementary Plan Dual Learning Platform

Presenter: Jessica Wade

# Specific Criteria for Elementary Virtual Learners

- “Successful” in virtual learning for the 2020-2021 school year defined by:
  - At or above grade level
  - District Data - iStation, DRA, Amira, Amplify, Imagine Math
  - State Data - STAAR, as applicable
  - SEL - Panorama Data
  - Teacher Recommendation
- Medically exempt students



# Student Choice

- **Considerations:**

- Offer K-5 virtual options for qualifying students.
- Include option for Special Education, Dyslexia, 504, and Rtl students, as applicable.

- **Recommendations:**

- Establish a virtual learning cohort for community building.
- Create virtual extracurricular\* options for students.

*\*No face to face options will be permitted.*



# Daily Routine for Students

- **Kindergarten - 3rd Grade**

- Synchronous / Asynchronous Instruction through Zoom and SeeSaw daily.
- Synchronous instruction would include both whole group and small group learning opportunities.

- **4th - 5th Grade**

- Synchronous / Asynchronous Instruction through Zoom and Canvas daily.
- Synchronous instruction would include both whole group and small group learning opportunities.



# Daily Routine for Students

- **Consistent Schedule**
  - 2 hours synchronous & 2 hours asynchronous daily
- **Synchronous & Asynchronous Expectations**
  - Project-Based Learning
  - Performance-Based Assessments
  - Portfolios
- **Home Kits**
  - Books/Manipulatives/Consumables
  - New home kit each six weeks to support learning goals
- **State Testing**
  - The district will comply with state expectations for all state testing and may require students to report to campus.



# Daily Routine for Students

- **Learning Coach**
  - Designated adult to serve as facilitator for the learning at home
  - Communication Liaison between home and school
  - Time commitment expectation - 3 hours per day
- **Student/Parent Contract for Elementary Virtual Learning**
  - Commit for 2021-2022 school year
  - Synchronous/Asynchronous time requirements
  - Learning coach commitment



# Daily Routine for Staff

- **Staffing for Virtual Learning**
  - Designated as virtual or face to face only
  - Maintain 22:1 ratio.
    - Staff may have students in multiple grades depending on enrollment.
- **Virtual Staff Expectations**
  - Establish a synchronous learning schedule (Total of 2 hours a day).
  - Provide lessons/activities for asynchronous instruction to approved learning platform
  - Communicate with learning coach and student regarding progress
  - Host conferences with learning coach and student



# Daily Routine for Staff

- **Selection**

- Teachers who have demonstrated high performance with virtual learners will be recommended by principals
- Volunteers will be solicited
- Strong communication skills will be critical in this role
- Interviews will be conducted, if necessary

- **Training**

- Explicit training for effective virtual instruction through M\*Powered Summer Academy and throughout the year
- Proposed Book Study - *Distance Learning Playbook*
- Tech Support/Training
- Continuous collaboration with virtual teachers and F2F teachers



# Daily Routine for Staff

- **Resources**

- Virtual teachers will follow the scope and sequence set forth by the district, as well as the district assessment calendar.
- District Resources
  - The TEKS Resource System,
  - Canvas/Seesaw,
  - District Assessments (universal screeners, pre/post PIs, etc.).
- Shared Portal
  - F2F and Virtual Teachers will create a shared portal with lessons/videos/activities for each grade level.



# Content

- **Content**

- All core content will be included (math, reading, science, and social studies).
- Specials (PE, music, art) activities will be provided via the approved learning platform.

- **Location**

- Virtual teachers will report to their current home campus.
- Virtual students will be assigned to their assigned home campus.





# Secondary Plan Dual Learning Platform

Presenters: Courtney Johnson, FSMS; Hollie  
Robinson, Midlothian Heritage High School

# Specific Criteria for Secondary Students

- “Successful” in virtual learning for the 2020-2021 school year defined by:
  - At or above grade level
  - State data - STAAR, as applicable
  - Teacher recommendation
- Medically exempt students



# Student Choice

- **Considerations:**

- Offer 6-12 virtual options for qualifying students
- Include option for Special Education, Dyslexia, 504, and Rtl students, as applicable

- **Recommendations:**

- Virtual learning cohort for community building
- Virtual extracurricular\* options for students

*\*No face to face options will be permitted.*



# Daily Routine for Students

- **Middle School**

- Synchronous/Asynchronous Instruction
  - Zoom and Canvas
  - Whole Group Instruction
  - Small Group Instruction

- **High School**

- Synchronous/Asynchronous Instruction
  - Zoom and Canvas
  - Whole Group Instruction
  - Small Group Instruction



# Daily Routine for Students

- **Consistent Schedule**

- Synchronous Expectations
  - 1+ hours per week, per class (assigned by teacher)
- Asynchronous Expectations
  - Daily
  - Project-Based Learning
  - Performance-Based Assessments
  - Portfolios

- **Testing**

- Assigned Testing Center - The MILE
- STAAR Assessments
  - Administered face-to-face per state guidelines.



# Parent Training/Parent Notification

- **Parent Training**

- MISD will provide required informational sessions for learning coaches (parents/guardians) of virtual learners to communicate the expectations of the students, parents and teachers involved in this program.

- **Student/Parent Contract for Secondary Virtual Learning**

- Commit for 2021-2022 school year
- Synchronous/Asynchronous time requirements
- Learning coach commitment



# Daily Routine for Staff

- **Teacher Selection**

- Demonstrated high performance with virtual learners and recommended by principals
- Volunteers may be solicited
- Strong communication skills will be critical in this role
- Interviews will be conducted for selection process

- **Teacher Training**

- Explicit training for effective virtual instruction through M\*Powered Summer Academy
- Tech Support/Training



# Daily Routine for Staff

- **Staffing for Virtual Learning**
  - Designated as virtual or face to face only
  - Staff may have multiple grades based on enrollment
  
- **Virtual Staff Expectations**
  - Establish an asynchronous learning schedule
  - Provide lessons/activities for asynchronous instruction to approved learning platform
  - Facilitate synchronous learning at least once per week
  - Office Hours



# Daily Routine for Staff

- **Teacher Resources**

- Virtual teachers will follow the scope and sequence set forth by the district
- District Resources
  - The TEKS Resource System
  - Canvas
  - District Assessments
- Shared Portal
  - F2F and Virtual Teachers will create a shared portal with lessons/videos/activities for each grade level.



# Content

- **Content**

- All core content will be included (Math, English, Science, and Social Studies).
- Some electives (PE, Music, Art, etc.) will be provided via the approved learning platform.

- **Location**

- Virtual teachers will teach from the home campus
- Virtual students will be assigned to their zoned campus





# Specialized Learning Plan Dual Learning Platform

Presenter: Shannon Thompson

# Specific Criteria for Specialized Learning

- “Successful” in virtual learning for the 2020-2021 school year defined by:
  - Progress on IEP goals
  - Progress Monitoring Data
  - District Data - iStation, DRA, Amira, Amplify, Imagine Math, Unit Assessments
  - State Data - STAAR, as applicable
  - Teacher Recommendation
- Medically exempt students



# Daily Routines for Specialized Learning

- **Speech:** Speech services would look the same as F2F. Students would log in with SLP for services. Preference would be speech students come in for therapy, especially if student's goal targets social needs. Asynchronous not recommended.
- **Dyslexia:** Services would be Synchronous matching service minutes in 504 or IEP
- **Related Services: OT/PT:** Services provided face to face only
- **Related Services: Counseling:** Services provided synchronously or face to face
- **Adaptive PE:** Services provided face to face unless on consult only



# Daily Routines for Specialized Learning

- **Inclusion:**
  - Instruction will occur during General Education synchronous instruction with opportunity for small group “breakout” sessions.
  - Inclusion not available for asynchronous instruction.
- **Content Mastery/GCS/The NET:**
  - Students with required minutes would log in at a set time
- **Resource:**
  - Synchronous instruction with mutually agreed up times for instruction and matching students' IEP.



# Daily Routines for Specialized Learning

- **CBI:**
  - Synchronous instruction at set times in small groups.
  - Parent training needed on how to assist with learning.
  - Minutes written in students' IEP's.
- **BAC:**
  - Face to face instruction recommended for work on social skills and goals.





# Next Steps

---

Presenter: Shorr Heathcote

## Next Steps

- **Wait on Texas Legislature Action**
- **Texas Education Agency**
  - Application for Virtual Learning Cohort for Support (they will select up to 50 districts)
  - Wait on TEA guidelines IF Legislature Acts to Approve some type of Virtual Learning for 2021-2022
- **If Legislature and TEA approves virtual learning, District will bring recommendations back to the Board for final approval.**





**Midlothian I.S.D. School Board Agenda Item Detail**  
**L.A. Mills Administrative Complex Boardroom**

<b>Board Meeting Date:</b>	<b>April 19, 2021</b>	
<b>Item:</b>	<b>Consider Recommendation for Irvin Principal &amp; Elementary # 8</b>	
<b>Supporting Document(s):</b>	<b>Electronic: Yes <input checked="" type="checkbox"/> No <input type="checkbox"/></b>	<b>Hard Copy: Yes <input type="checkbox"/> No <input checked="" type="checkbox"/></b>
<b>Background Information:</b>	<p>There were 86 applicants for the positions. The staff and parents at Irvin Elementary had the opportunity to share characteristics they felt were important in a principal for Irvin. The applicants were screened and nine applicants were selected to interview. The applicants went through a live interview process with the interview committee which included 2 parents and 2 teacher representatives from Irvin Elementary, 2 parents and 1 teacher from Miller Elementary, and District Administrators.</p>	
<b>Fiscal Impact/Budget Function Code:</b>	NA	
<b>Policy:</b>	NA	
<b>District Goal:</b>	Attract, support, develop, and retain exceptional personnel	
<b>Administration Recommended Option:</b>	The administration recommends the board approve Administrative Contract Recommendations as presented. .	
<b>Motion:</b>	<p>A motion might be, "I move to approve the Administrative Contract Recommendation for _____ as Irvin principal."</p> <p>A motion might be, "I move to approve the Administrative Contract Recommendation for _____ as Elementary #8 principal."</p>	
<b>Presenter:</b>	Courtney Carpenter	

**Midlothian I.S.D. School Board Agenda Item Detail**  
**L.A. Mills Administrative Complex Boardroom**

<b>Board Meeting Date:</b>	<b>April 19, 2021</b>	
<b>Item:</b>	<b>Consideration of Fourth Quarter, 2020 Demographic Report</b>	
<b>Supporting Document(s):</b>	<b>Electronic: Yes <input checked="" type="checkbox"/> No <input type="checkbox"/></b>	<b>Hard Copy: Yes <input type="checkbox"/> No <input checked="" type="checkbox"/></b>
<b>Background Information:</b>	Mr. Brent Alexander of <b>School District Strategies</b> will present the “2020 Fourth Quarter Demographic Report” with the latest data and projections. He will be available for questions. The Fourth Quarter Demographic presentation has been finalized and is attached.	
<b>Fiscal Impact/Budget Function Code:</b>	NA	
<b>Policy:</b>	NA	
<b>District Goal:</b>	Facilitate budget process and building designs through allocated district resources that foster flexible and innovative learning spaces.  Develop a comprehensive staffing plan to foster innovation, effective communication and a high-performing culture throughout the district.	
<b>Administration Recommended Option:</b>	No recommendation ... presentation only	
<b>Suggested Motion</b>	Presentation only	
<b>Presenter:</b>	Courtney Carpenter	



# Midlothian ISD

District  
Demographics  
Update

4Q 2020



School District Strategies  
*Solutions Through Demographics*

# DFW NEW HOME MARKET REMAINS RED HOT

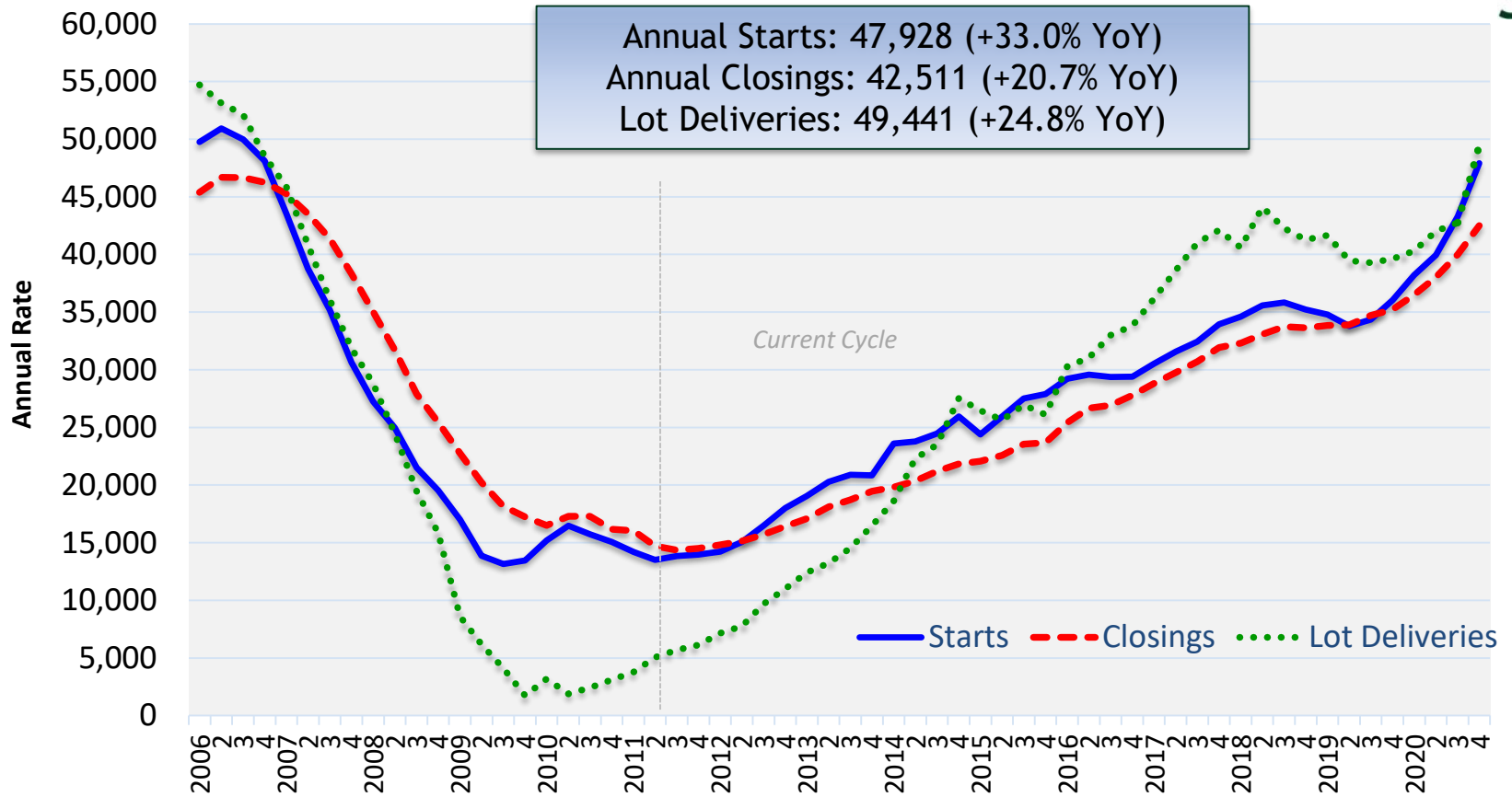

## Starts & Inventory

- Record/strong 4Q20 sales period continues into 2021
- Builders continue to ramp up starts to nearly 48K units, about 3K units below 2Q06 record pace of 51K annual starts
- In many cases, builders are raising prices or limiting sales to stem wave of demand—but buyers keep coming.

# FOUR INGREDIENTS THAT HAVE MADE HOUSING SO STRONG DURING THE TIME OF COVID



## 1. Declining 30-Year Mortgage Rate

- Since 4Q18, rate has dropped over 200 basis points
- Under 3% financing means households forced into rental because of affordability concerns are being ‘unlocked’

## 2. Emerging Millennial Household

- Leading edge Millennials (now in mid-to-late 30’s) are starting families; desire detached SF homes; urgency to take advantage of low rates

## 3. Tightening Existing Home Market

- Inventory was tight going into pandemic. Has been stripped with lower rates. Prospective buyers have very few choices. Must turn to new homes, especially for < \$350K housing selection.

## 4. Changing Attitude About Outer Ring Locations

- Previous hesitancy over drive times has changed with work-from-home options. Increased emphasis on quality of neighborhood and home space has buyers embracing exurban locations.

COVID-19 environment and changing attitudes about working from home appears to have also increased the number of households that are willing to homeschool their children

# 30-YEAR MORTGAGE RATE

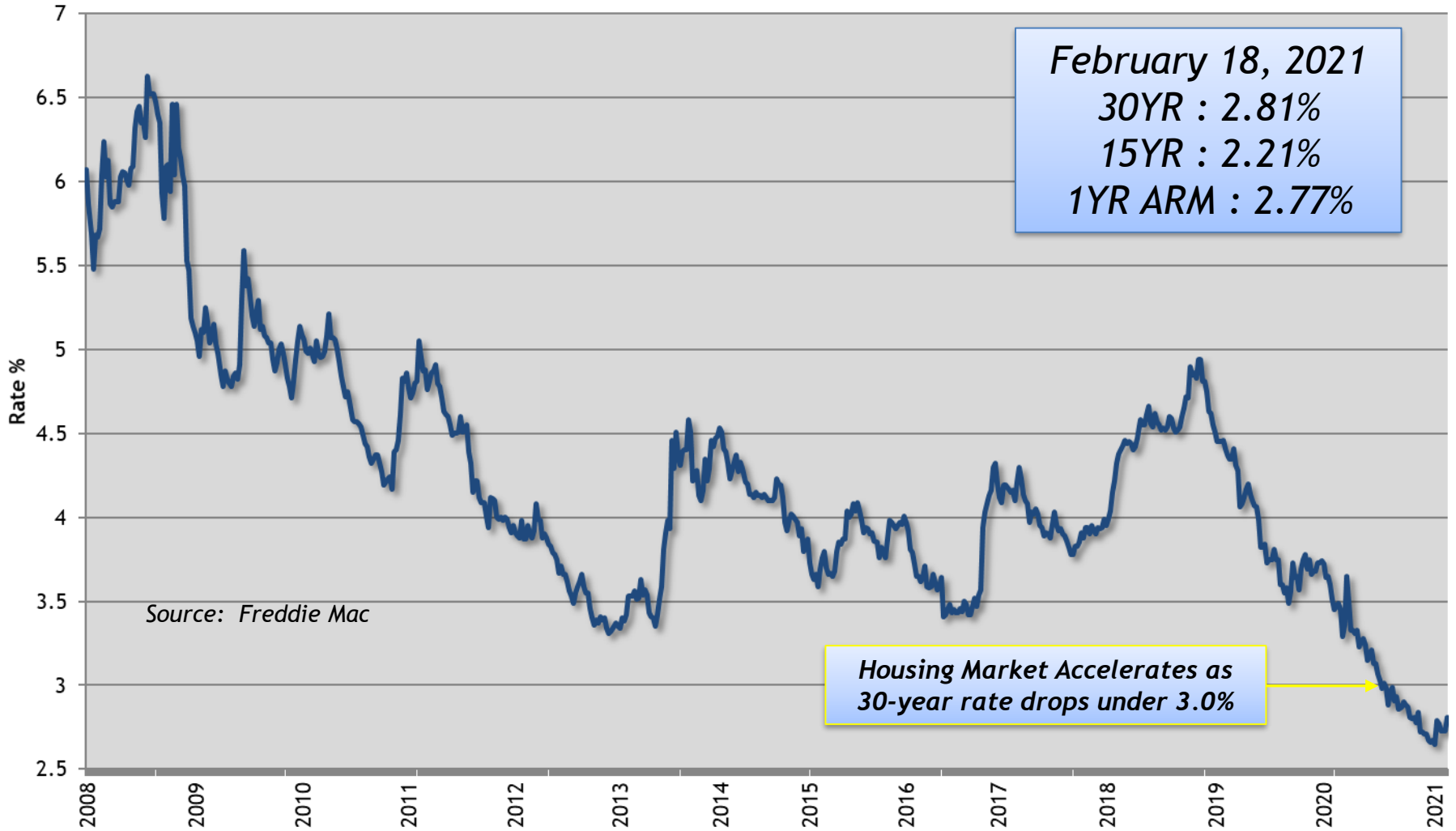

# 2025 DFW TARGET NEW HOME BUYER POOL

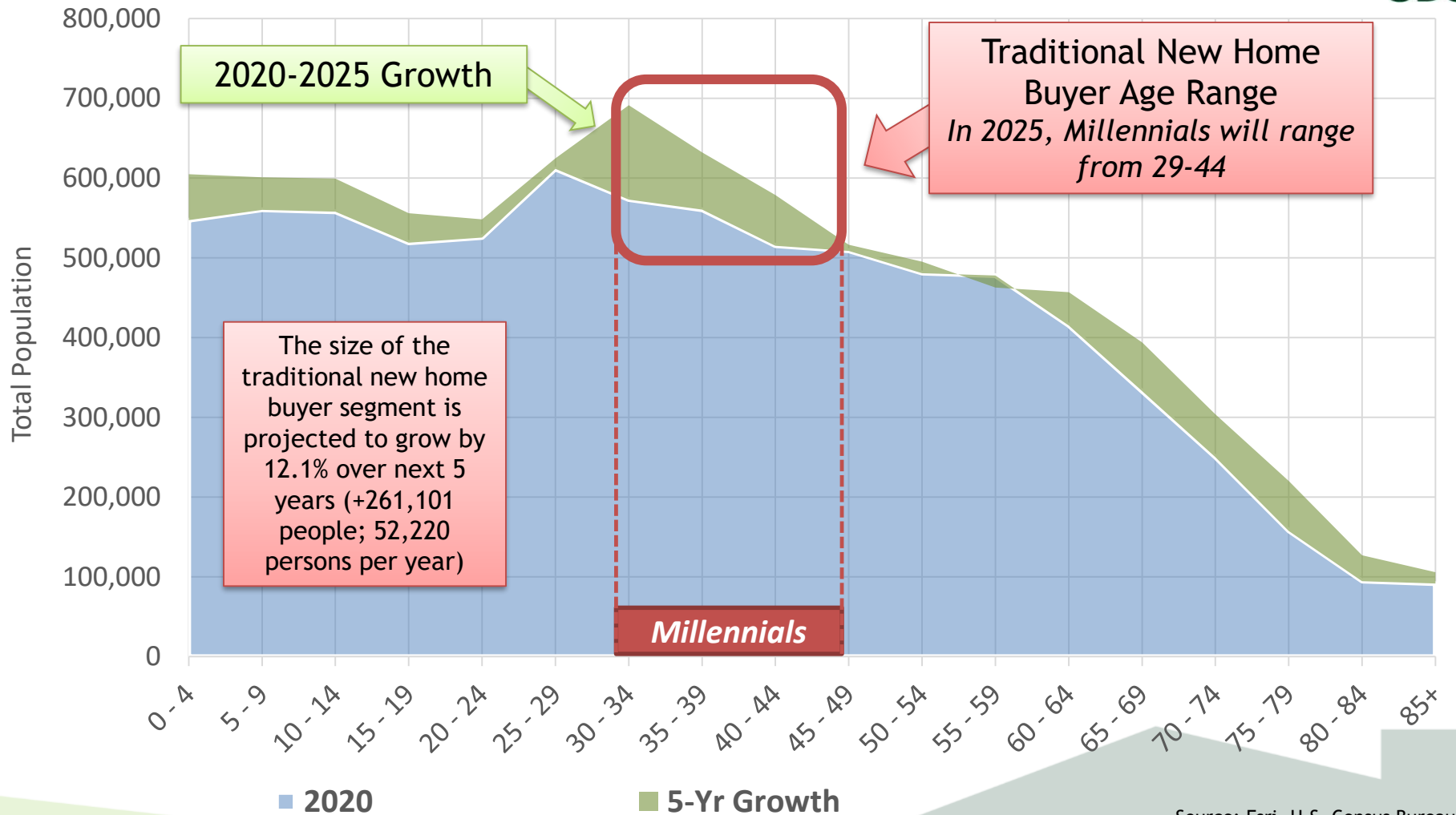

Source: Esri, U.S. Census Bureau

# DFW EXISTING HOME MARKET—LISTINGS HELD BACK BY COVID-19

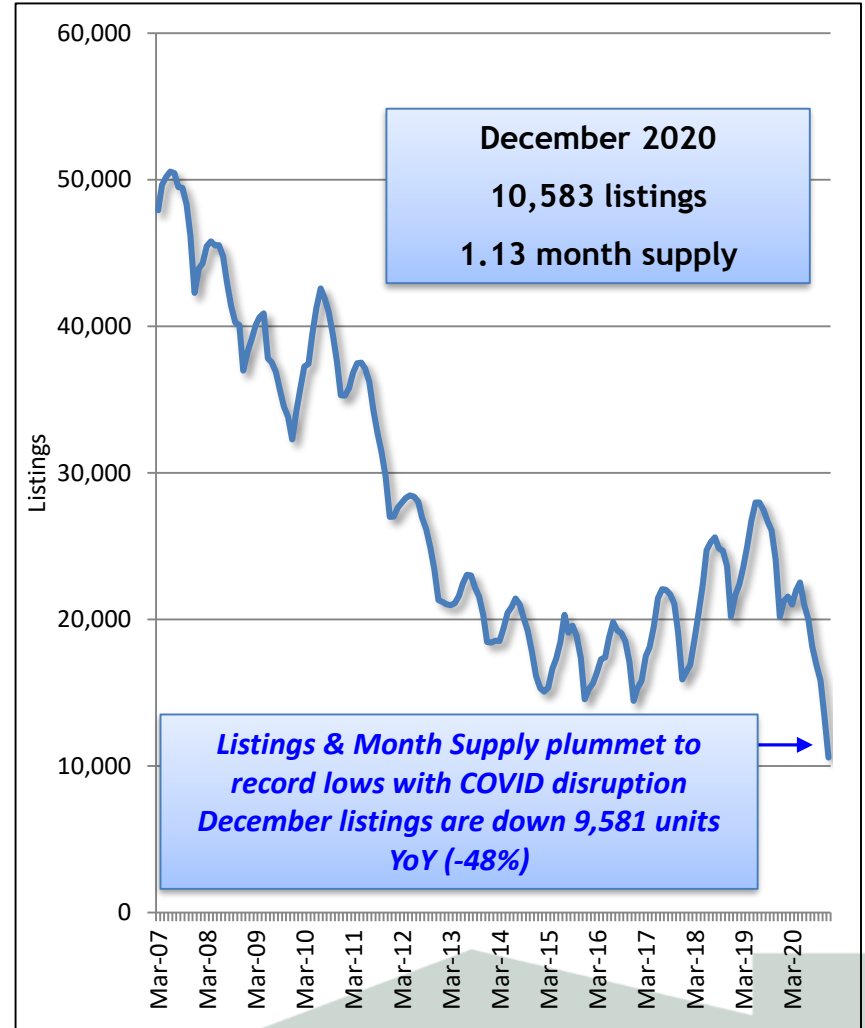
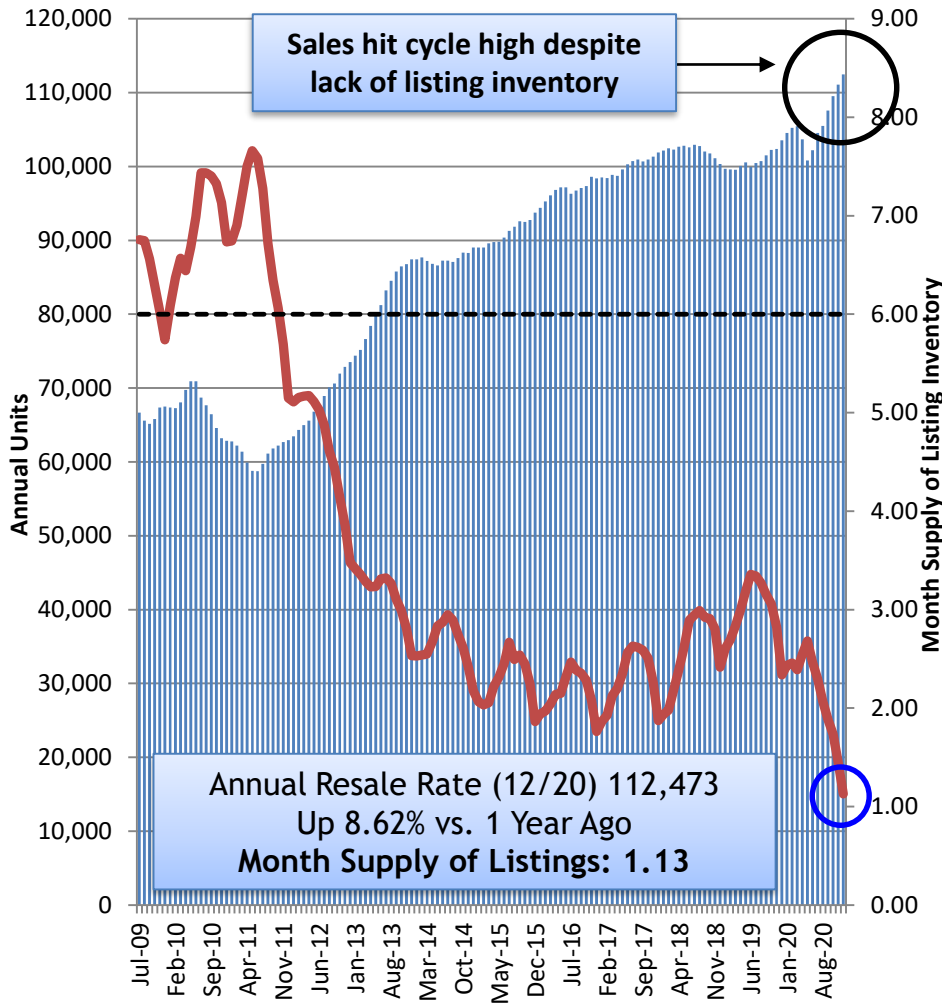

Source: Texas A&M Real Estate Center

# DFW ANNUAL EMPLOYMENT GROWTH

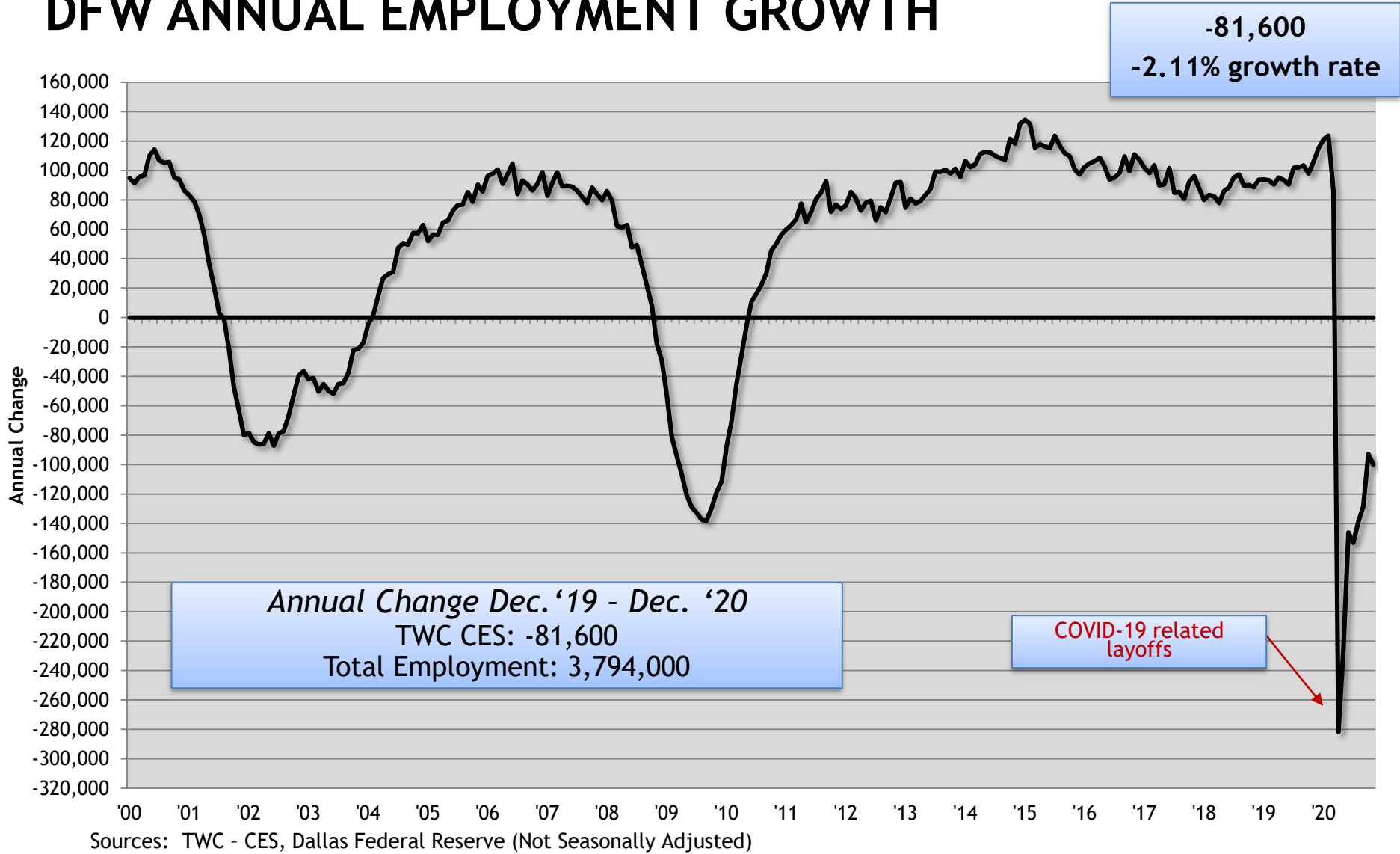

# MONTHLY CHANGE IN DFW EMPLOYMENT

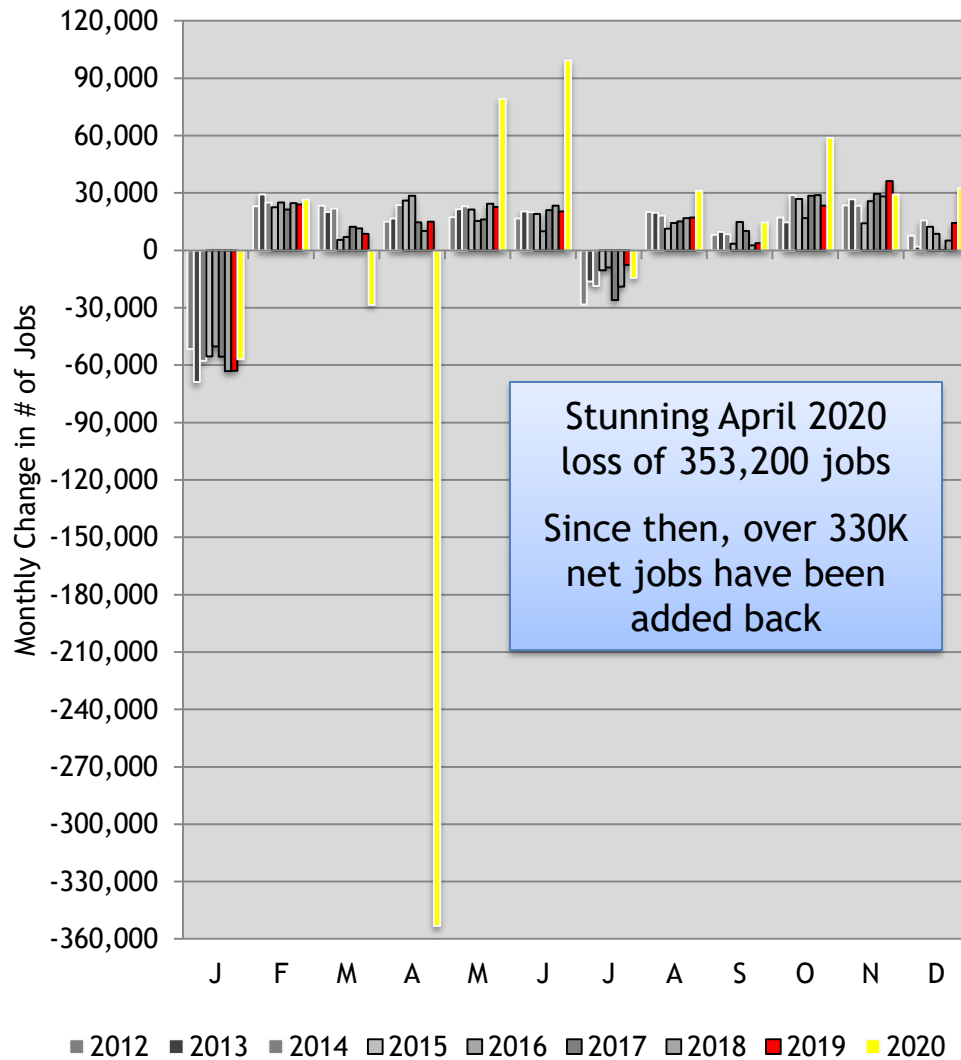

December 2020	Annual Change	% Change
Mining, Log, Construction	-4,000	-1.7
Manufacturing	-9,300	-3.2
Trade, Transp, Util	7,300	0.9
Information	-2,700	-3.2
Financial Activities	<b>10,900</b>	3.4
Prof & Bus Services	<b>21,200</b>	3.3
Edu. & Hlth Serv.	<b>-32,400</b>	-6.8
Leisure & Hospitality	<b>-64,000</b>	-15.9
Other Services	-2,900	-2.3
Government	-5,700	-1.3

Source: TWC—CES Survey (Not Seasonally Adjusted)

# DFW NEW HOME MARKET OUTLOOK

## 2021 Outlook

- With large backlogs already established and the Spring market yet to come, new home sales should not be a worry in 2021
- Limited construction capacity, a supply chain under stress and a lack of lots in ‘gapped-out’ neighborhoods should act as a governor to the market from a start perspective
- Growing demographics, low mortgage rates, and a tight existing home market should make 2021 another banner year

## Long Term Concerns

- *Housing markets are cyclical—so what are the future changes that could possibly dampen future new home demand?*
- 30-Year Mortgage Rate
  - Looks great for 2021, but as the economy recovers, the yield on the 10-Year Treasury may rise. A 30-Year rate over 3.5% would remove the current ‘fervor’ from the housing market.
- Affordability
  - Housing inflation is back. As we saw in 4Q18, rising house prices and climbing mortgage rates can mute the housing market
- Job Growth
  - Job growth was negative in 2020 and should turn positive this year. While it looks like the corporate relocation process should start back up again, getting DFW back to plus-100K net annual job growth is a prerequisite to sustain the current annual housing start rate



# MIDLOTHIAN PREOWNED HOME SALES

Midlothian ISD - Annual Resales

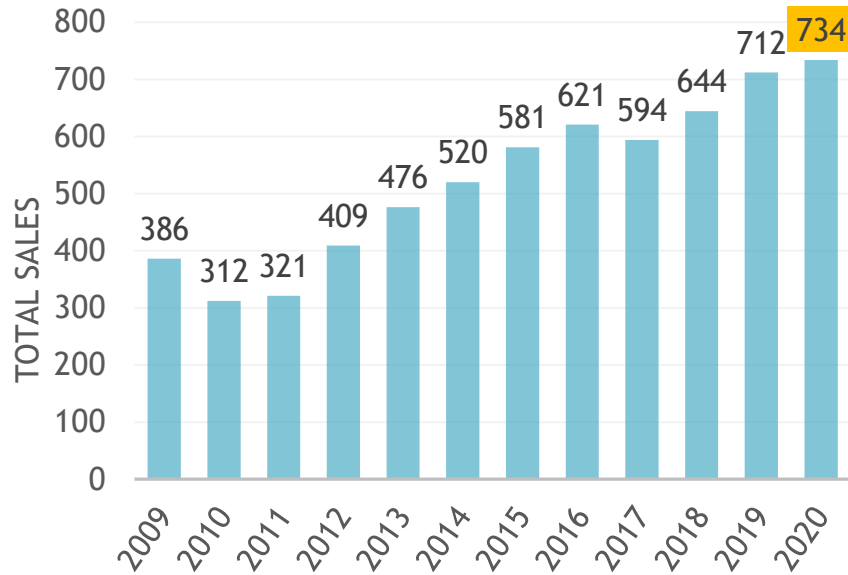

Median Resale Price Comparison

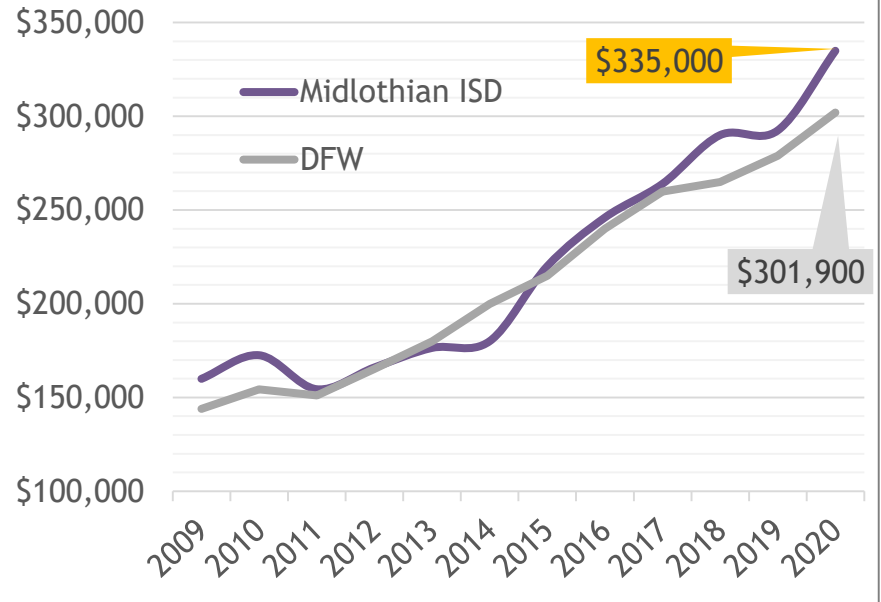

Source: NTRIS – SF detached, non-builder sales only

- From 2015-2019, MISD has seen an average of 630 pre-owned home sales per year
- 734 total resales in the district in 2020 (+3.1% YoY); exceeds the previous 5-year annual average
- MISD's median resale sold price in 2020 was a record \$335,000 (+14.5% vs. YoY)
- DFW's annual median resale price currently \$301,900 (+8.3% YoY)



# MIDLOTHIAN ISD QUARTERLY NEW HOME CONSTRUCTION

**MISD sees record activity in 4Q20**

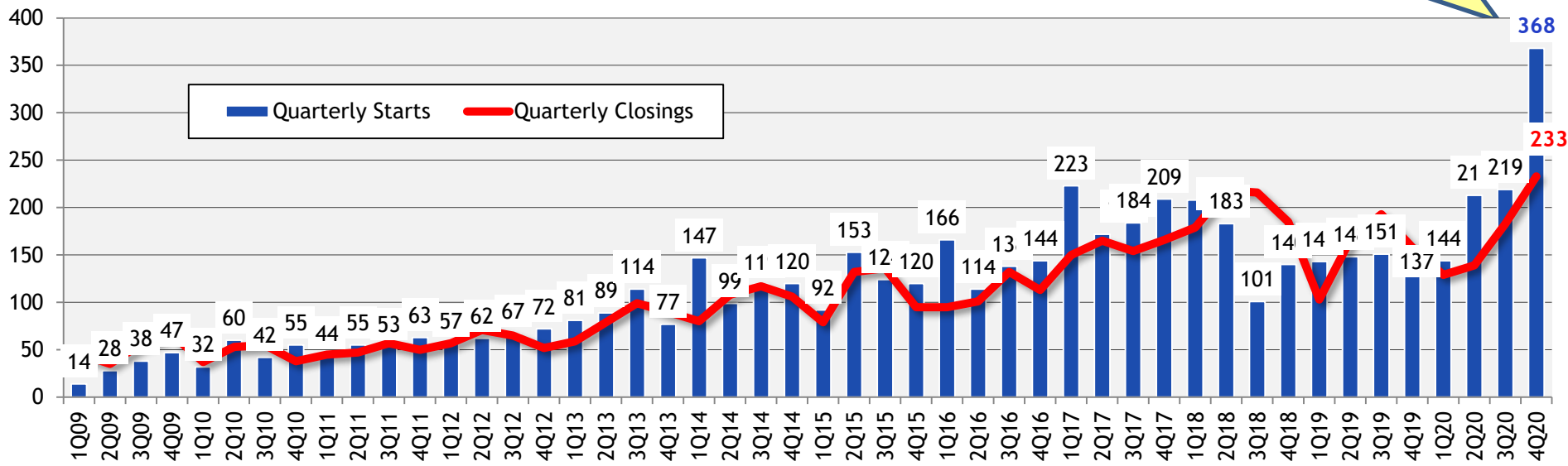

Starts	2013	2014	2015	2016	2017	2018	2019	2020
1Q	81	147	92	166	223	208	143	144
2Q	89	99	153	114	172	183	148	213
3Q	114	119	124	138	184	101	151	219
4Q	77	120	120	144	209	140	137	368
<b>Total</b>	<b>361</b>	<b>485</b>	<b>489</b>	<b>562</b>	<b>788</b>	<b>632</b>	<b>579</b>	<b>944</b>

Closings	2013	2014	2015	2016	2017	2018	2018	2020
1Q	59	80	79	95	150	179	103	129
2Q	79	108	132	101	165	218	166	139
3Q	99	117	136	132	154	216	193	183
4Q	90	106	95	113	166	185	158	233
<b>Total</b>	<b>327</b>	<b>411</b>	<b>442</b>	<b>441</b>	<b>635</b>	<b>798</b>	<b>620</b>	<b>684</b>

- Builders started 368 and closed 233 new homes in the district during the 4th quarter of 2020
  - Both are new quarterly records



# MIDLOTHIAN ISD ANNUAL NEW HOME CONSTRUCTION AND LOT DELIVERIES

**Record starts and lots delivered in 2020**

**2020 Annual Totals/Change**  
**944 Starts: +63% (+365 homes)**  
**684 Closings: +10.3% (+64 homes)**

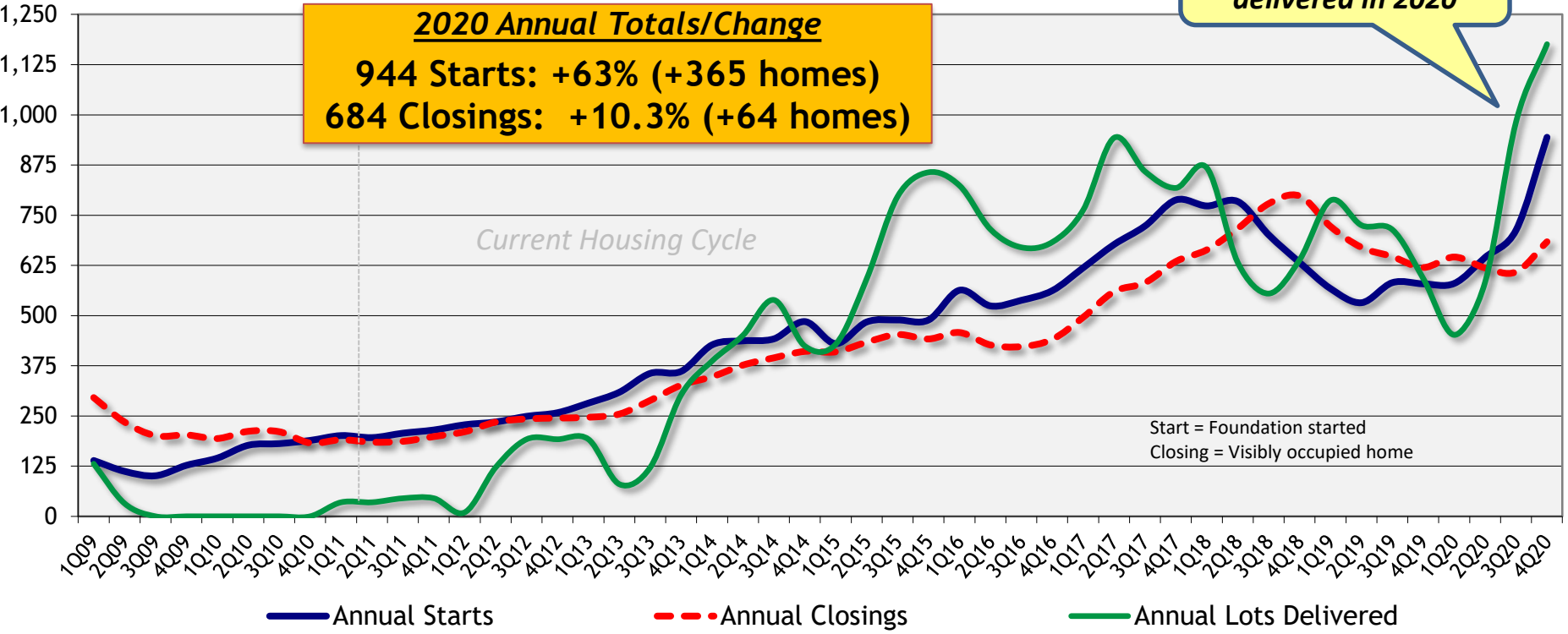

- 944 annual starts in MISD during 2020, a 63% increase over 2019
  - Record high for annual starts
- Annual closings increase to 684 homes, up 10.3% vs. the same period last year
- Developers delivered 1,176 new single-family residential lots in MISD in 2020
  - Also a record high in a 12-month period



# DFW SCHOOL DISTRICT NEW HOME ACTIVITY RANKED BY ANNUAL NEW HOME CLOSINGS 1Q20-4Q20

Rank	District	Annual Starts	Annual Closings	Median New Home Price
1	Denton	3,172	2,929	\$322,323
2	Prosper	3,072	2,814	\$455,746
3	Northwest	3,224	2,524	\$340,508
4	Frisco	2,377	2,500	\$549,653
5	Eagle Mountain-Saginaw	2,260	2,265	\$274,813
6	Forney	2,459	1,737	\$272,192
7	Lewisville	1,015	1,198	\$437,655
8	Crowley	923	1,171	\$276,490
9	Rockwall	1,178	1,051	\$366,153
10	Princeton	1,264	1,042	\$273,812
11	Dallas	847	964	\$332,706
12	Mansfield	1,093	922	\$386,166
13	McKinney	920	908	\$401,615
14	Little Elm	810	893	\$382,596
15	Royse City	1,283	882	\$269,000
16	Waxahachie	962	875	\$331,859
17	Melissa	1,073	834	\$341,922
18	Anna	909	738	\$282,073
19	Wylie	825	709	\$387,837
20	Midlothian	944	684	\$360,211

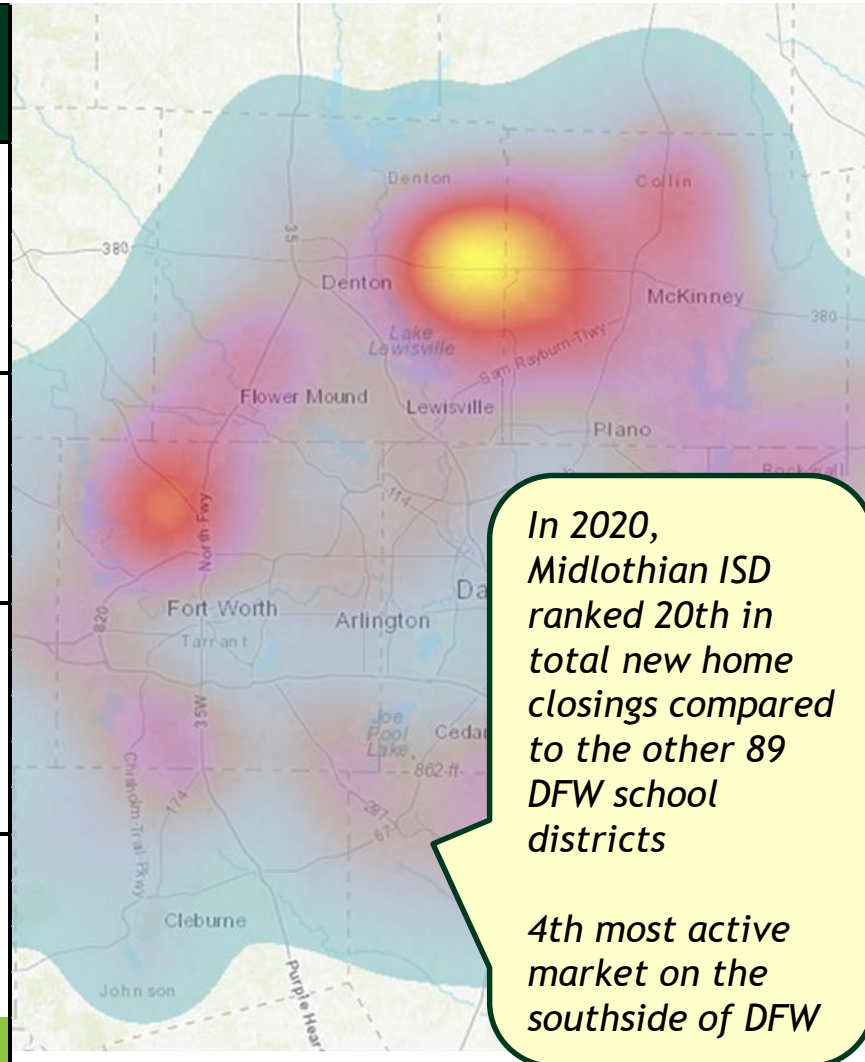

# MIDLOTHIAN ISD TOP PRODUCING NEW HOME SUBDIVISIONS 1Q20-4Q20 (ranked by annual closings)

Rank	Subdivision	Annual Starts	Annual Closings	Elementary	Middle	High
1	Massey Meadows	107	88	Longbranch	Walnut Grove	Heritage
2	Hawkins Meadows	35	67	Irvin	Frank Seale	Midlothian
3	Mill Valley	61	50	Vitovsky	Frank Seale	Midlothian
4	Four Trees	31	48	McClatchey	Walnut Grove	Heritage
5	Coventry Crossing	100	40	Mt. Peak	Dieterich	Midlothian
6	La Paz Ranch	23	40	Miller	Dieterich	Midlothian
7	Legacy Estates	58	36	Longbranch	Walnut Grove	Heritage
8	Dove Creek	16	36	Mt. Peak	Dieterich	Midlothian
9	Autumn Run	64	35	Irvin	Frank Seale	Midlothian
10	Patriot Estates	84	30	Vitovsky	Frank Seale	Midlothian
11	Thomas Trail Estates	24	28	Mt. Peak	Dieterich	Midlothian
12	The Grove	25	23	Baxter	Walnut Grove	Heritage
13	Lawson Farms	4	23	Miller	Dieterich	Midlothian
14	Hillstone Estates	7	18	Miller	Dieterich	Midlothian
15	Bryson Manor	4	18	McClatchey	Walnut Grove	Heritage



*Prairie Ridge*



*Greenway Trails*

## Others to Watch

- Greenway Trails: D.R. Horton Homes starts 106 homes in 4Q20
- Prairie Ridge: Beazer and Trophy Signature kick off activity with 95 homes starts over the past 9 months



# MIDLOTHIAN ISD NEW HOME CONSTRUCTION ACTIVITY BY ELEMENTARY ATTENDANCE ZONE

## Annual Starts & Closings 1Q20-4Q20

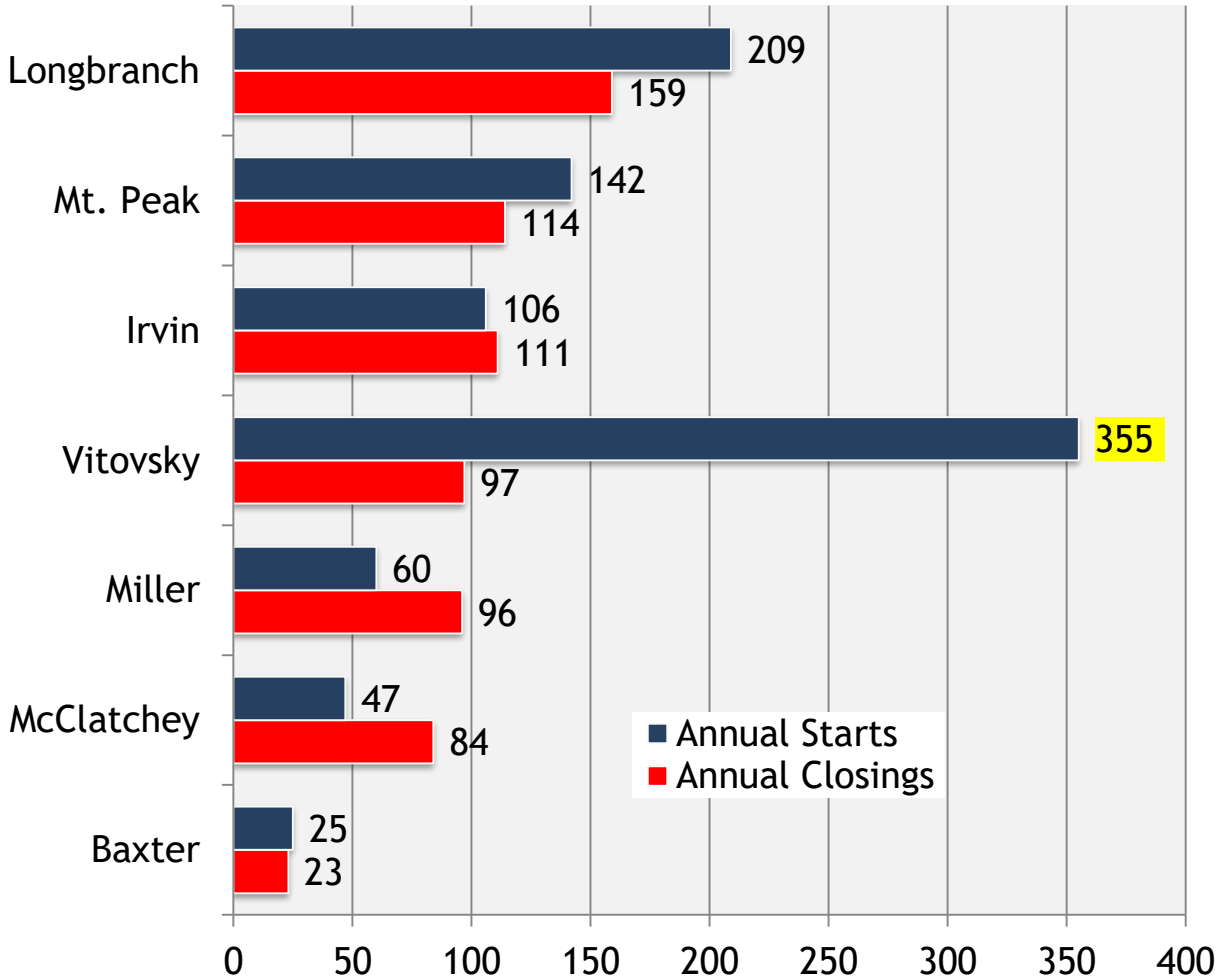

- Vitovsky zone starts skyrocket in 2020 to 355 units
- Longbranch ES produces the most closings in 2020 with 159
- Mt. Peak and Irvin zones all see more than 100 new homes occupied over the past 12 months

*\*\*Data based on current 2020/21 attendance zones*



# MIDLOTHIAN ISD NEW HOME CONSTRUCTION ACTIVITY BY MIDDLE SCHOOL ATTENDANCE ZONE

*\*\*Data based on current 2020/21 attendance zones*

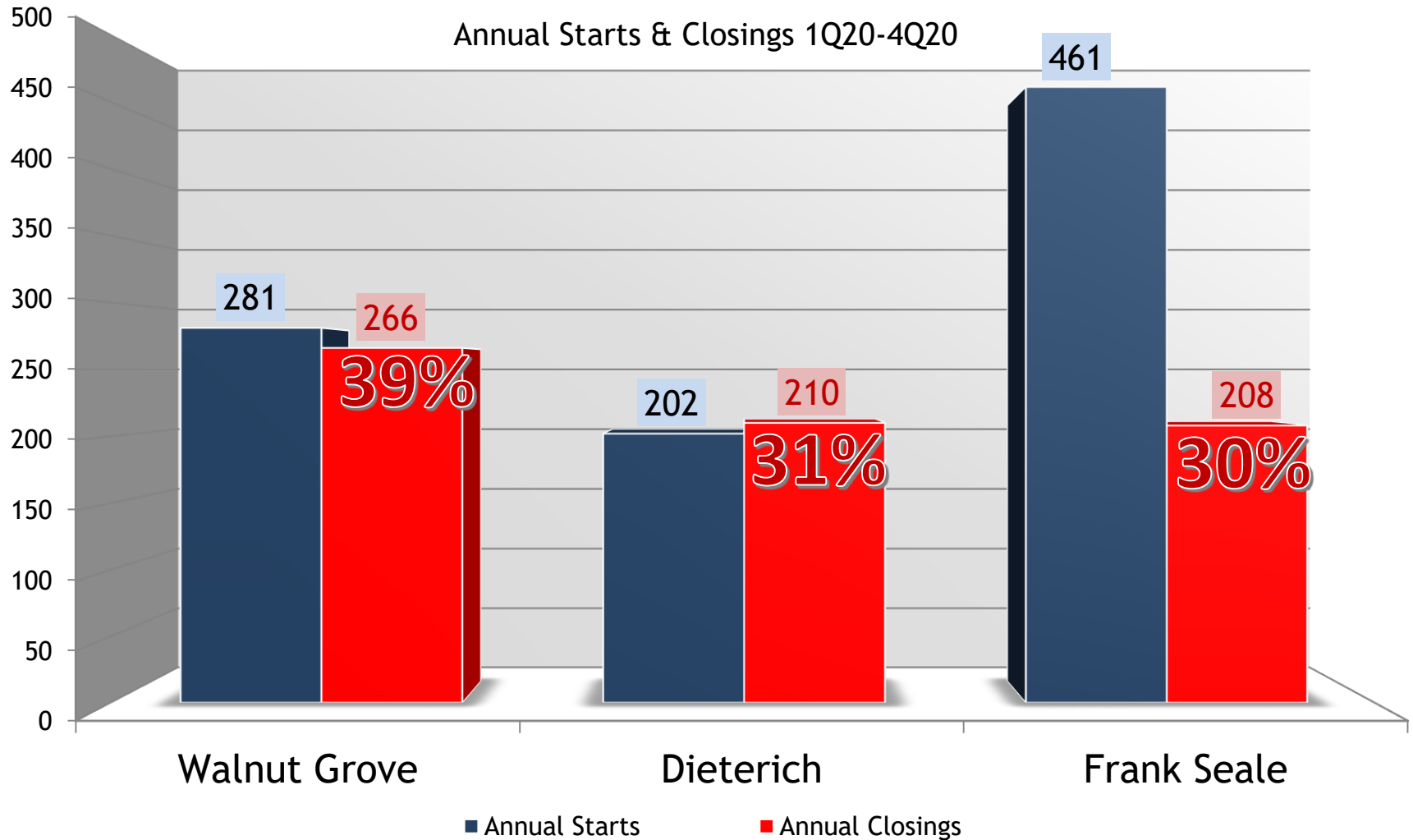



# MIDLOTHIAN ISD NEW HOME CONSTRUCTION ACTIVITY BY HIGH SCHOOL ATTENDANCE ZONE

*\*\*Data based on current 2020/21 attendance zones*

Annual **Starts** Rate Per High School Zone

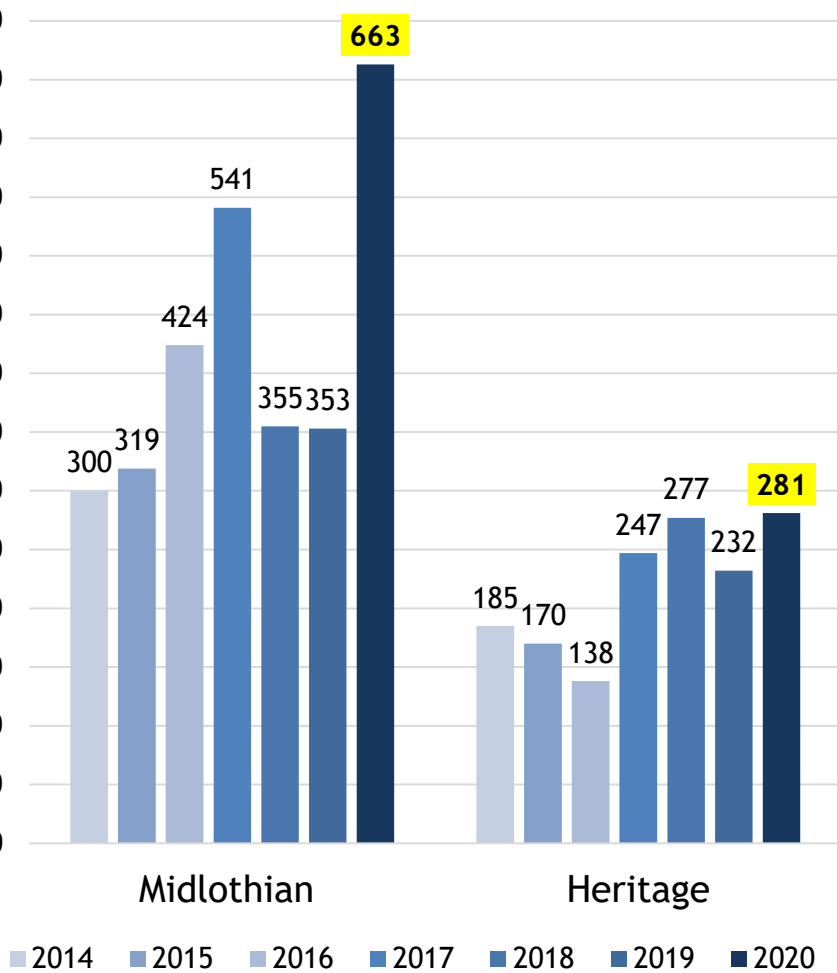

Annual **Closings** Rate Per High School Zone

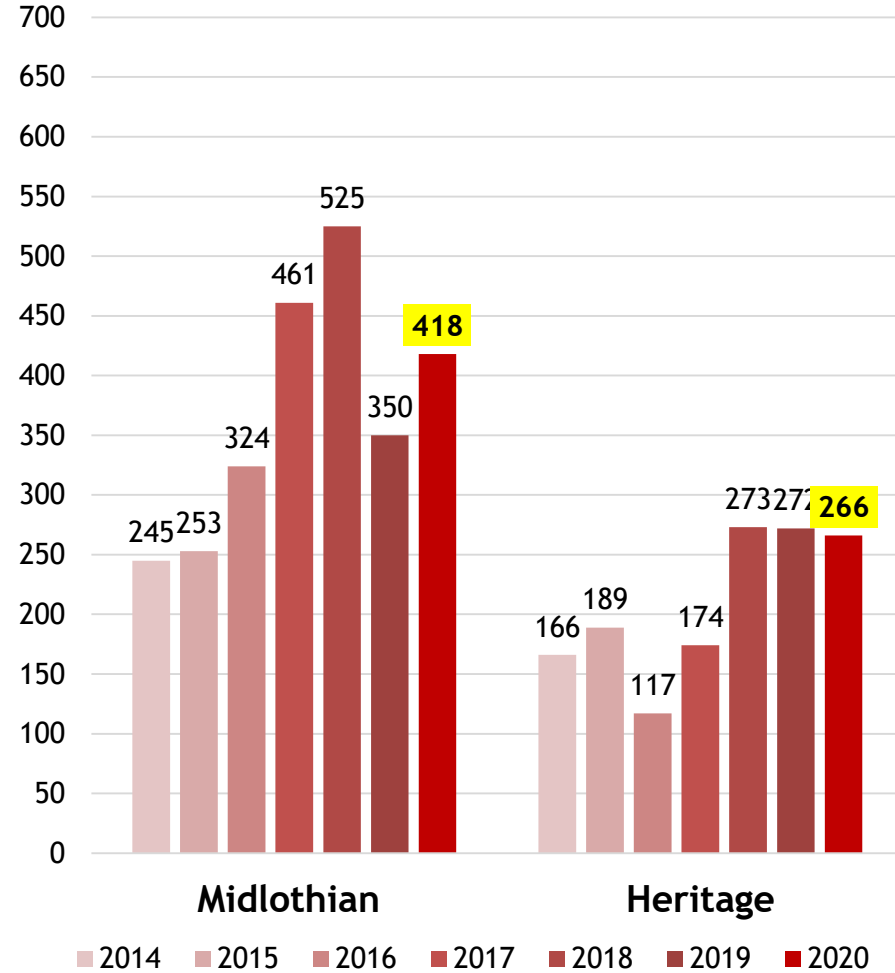



# DISTRICT MEDIAN NEW HOME PRICE HISTORY

### Annual Activity: 2020

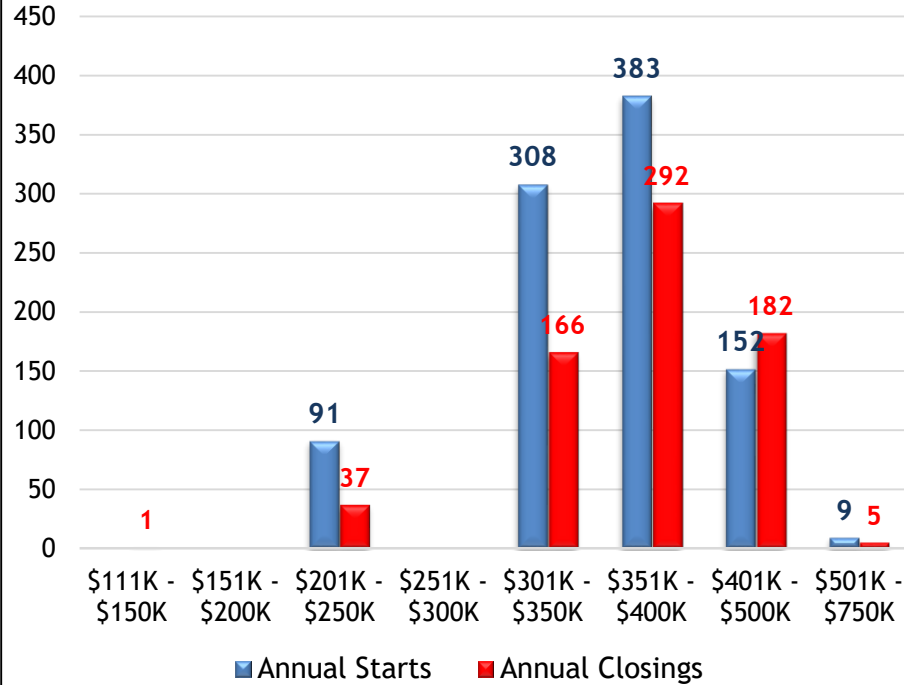

### Historical Median New Home Price

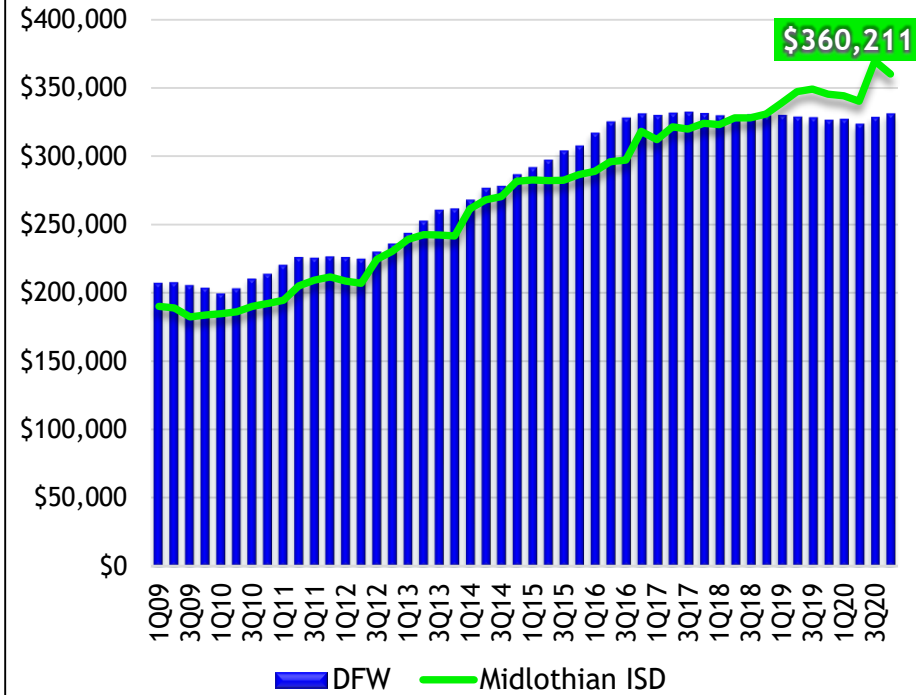

- 90% of the district’s new home starts located in subdivisions with average base pricing over \$300K
- District’s median new home price now stands at \$360,211 (+4.3% Y-o-Y)
- DFW Median New Home Price is currently \$330,475 (1.4% Y-o-Y)



# MIDLOTHIAN ISD RESIDENTIAL LOT INVENTORY

- **619 homes in production at Y/E 2020** (total of homes under construction, finished vacant, and models)
- **1,530 vacant developed lots remaining as of month-end December 2020**
- **1,434 lots under development at the end of 4Q20**

LOTS UNDER DEVELOPMENT 4Q20					
Subdivision	Phase / Section (s)	Lot Width (s)	Total Lots	Attendance Zones	City
Summit at Lake Ridge	22-B	130'	33	Vitovsky/Frank Seale/Midlothian	Cedar Hill
Cross Creek	8	150'	4	Longbranch/Walnut Grove/Heritage	Ellis County Uninc.
Jordan Run Estates*	4	150'	75	Mt. Peak/Dieterich/Midlothian	Ellis County Uninc.
Heritage Towne	1	50', 60'	104	Vitovsky/Frank Seale/Midlothian	Grand Prairie
Prairie Ridge*	2C	60'	99	Vitovsky/Frank Seale/Midlothian	Grand Prairie
Greenway Trails *	3 & 4	60', 65', 75'	262	Vitovsky/Frank Seale/Midlothian	Grand Prairie
Southpointe	8A	50', 75'	67	Vitovsky/Frank Seale/Midlothian	Mansfield
Brandi Ridge	3	120'	105	Mt. Peak/Dieterich/Midlothian	Midlothian
Hayes Crossing	1cp	85'	160	Longbranch/Walnut Grove/Heritage	Midlothian
Lakes of Somercrest *	1	60'	99	Miller/Dieterich/Midlothian	Midlothian
Mockingbird Springs	2	150'	36	Longbranch/Walnut Grove/Heritage	Midlothian
Parks of Somercrest *	1	60'	56	Miller/Dieterich/Midlothian	Midlothian
Parkside Estates	North	60'	73	Baxter/Walnut Grove/Midlothian	Midlothian
Sagebrush *	1	160'	67	Longbranch/Walnut Grove/Heritage	Midlothian
Wind Ridge	1	70'	83	Longbranch/Walnut Grove/Heritage	Midlothian
Bryson Manor	3	110'	111	McClatchey/Walnut Grove/Heritage	Ovilla

\*New or updated in 4Q20



# MISD PROPOSED RESIDENTIAL PROJECTS

(not currently active or under development)

- *\*New or updated in 4Q20*
- *\*\*Initial prelim plat denied by P&Z*

Subdivision	Proposed Lots	Elementary Zone
Mockingbird Heights	97	Baxter
Redden Farms	792	Baxter
Villages of Walnut Grove*	187	Baxter
Villas on the Square**	90	Irvin
Avilla Woodstone**	200	Irvin
Z11-2015-48**	67	Irvin
Bridgewater	1,425	Longbranch
Mockingbird Farms	4	Longbranch
West Highland Estates*	33	Longbranch
Heritage Glen	16	McClatchey
Hidden Lakes on Mockingbird	128	McClatchey
Stonewood Lakes Estates	143	McClatchey
Z21-2020-087 (The Arbours)	46	McClatchey
Diamond J Ranch	400	Miller
Ridgepoint*	144	Miller
Shady Valley Estates	115	Miller
Spring Creek Estates	104	Miller
Southpointe	35	Mt. Peak
Cottonwood Creek	325	Vitovsky
Highland Meadows	881	Vitovsky
Lakeview Hills	4,077	Vitovsky
Padera Residential	214	Vitovsky
Westside Preserve	787	Vitovsky
Windsor Hills	527	Vitovsky

- 13,161 additional single-family lots are planned in MISD
- Combined there are nearly 16,800 lots in-process/planned as of Y/E 2020 in MISD (total of homes U/C, VDL, lots U/D, and future lots)

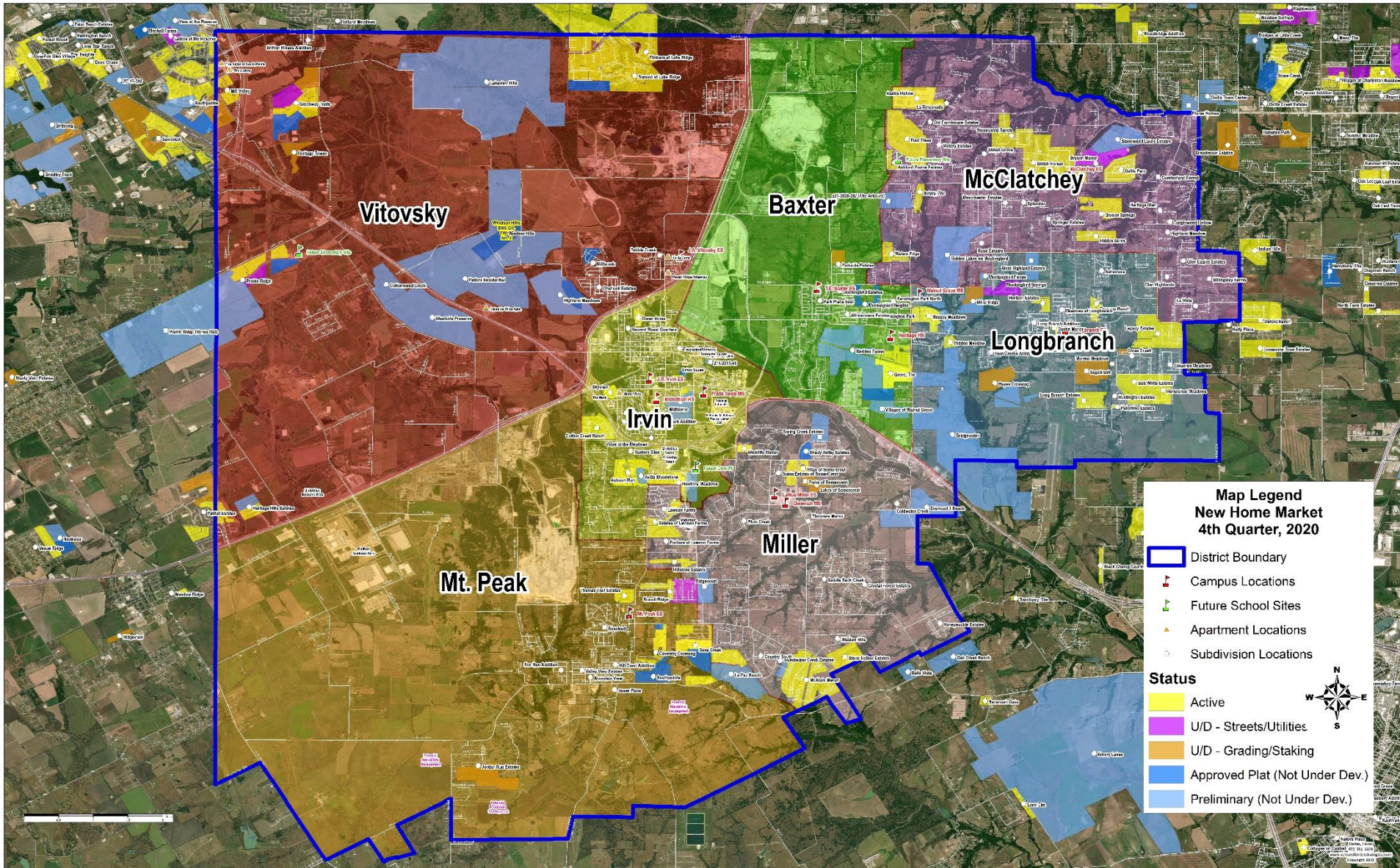



# AERIAL PHOTOS

## JANUARY 5, 2021



# SOUTHPOINTE/MILL VALLEY





# GREENWAY TRAILS



SH 360 Toll



# HERITAGE TOWNE



SH 360 Toll

SH 281



# PRAIRIE RIDGE

SH 287





# AUTUMN RUN



FM 663



School District Strategies



# HAWKINS MEADOWS



FUTURE ES #8

S. 14<sup>TH</sup> STREET



# BRANDI RIDGE



S. 14<sup>TH</sup> STREET

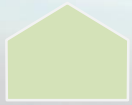

# DOVE CREEK





# LA PAZ RANCH (N)





# COVENTRY CROSSING





# STONE HOLLOW ESTATES



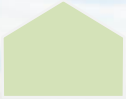

# LAKES/PARKS/VILLAS OF SOMERCREST



Dieterich MS

Miller ES



# THE GROVE



WALNUT GROVE RD



# HAYES CROSSING





# MASSEY MEADOWS



HERITAGE HS

WGMS



# WIND RIDGE (BLOOMFIELD)





# BRYSON MANOR





# MIDLOTHIAN ISD NEW HOME CONSTRUCTION CLOSINGS FORECAST FALL 2021-2030

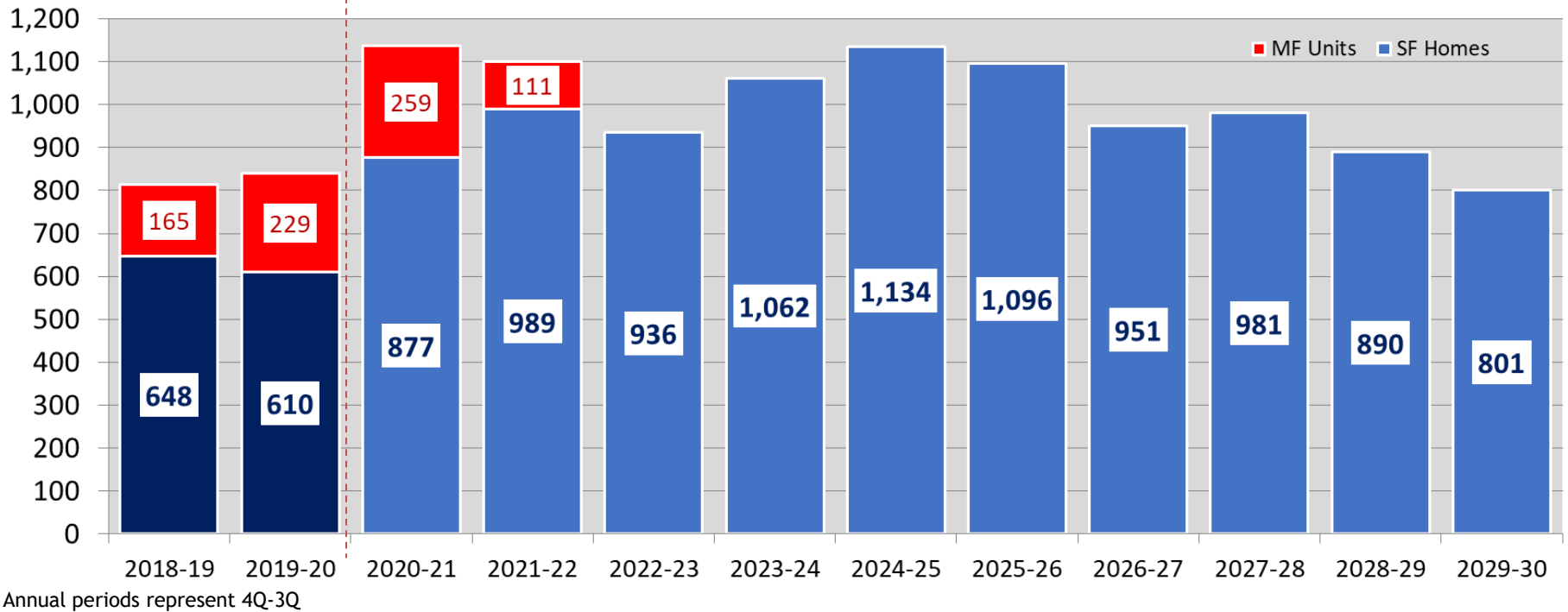

- New home construction in the district is accelerating; district is poised to see an average of an average of 933 closings over the next two years, increasing upwards to near 1,000-1,200 by 2025
- Under the revised Moderate Scenario, MISD builders could produce approximately 5,000 total new homes by Fall 2025
- Over the next 10 years, MISD is poised to see about 9,700 new homes new homes built
- The Aubrey (at South Pointe) apartments are currently under construction which will bring another 211 units in addition to the 157 new units at Padera Lakeside Villas



# MIDLOTHIAN ISD STUDENT YIELDS ANALYSIS



Average Student Yield



➤ *The average yield per new home in subdivisions with active new home construction is currently 0.64 per home*

Average Student Yield Per Apartment Unit



➤ In 2020, the district's average multi-family yield declines to 0.26 enrolled students per apartment unit

*Data Reflects Students  
Enrolled in MISD*



# MIDLOTHIAN ISD

## 10-YEAR ENROLLMENT PROJECTIONS (4Q20 DRAFT)

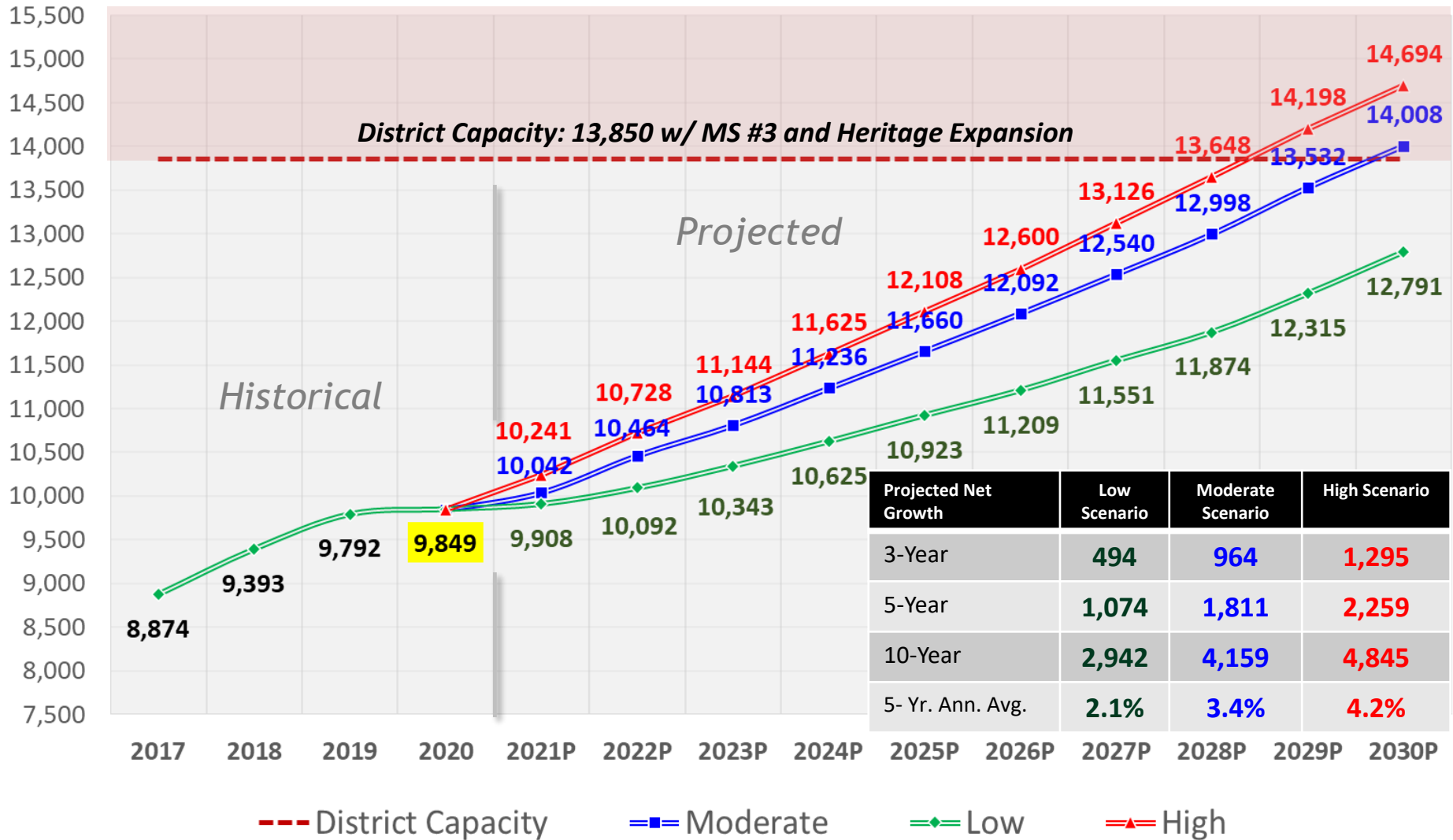

Projected Net Growth	Low Scenario	Moderate Scenario	High Scenario
3-Year	494	964	1,295
5-Year	1,074	1,811	2,259
10-Year	2,942	4,159	4,845
5-Yr. Ann. Avg.	2.1%	3.4%	4.2%



# ELEMENTARY CAMPUS PROJECTIONS VS. CAPACITY



Midlothian ISD - Campus Projections (Moderate Scenario)	Historical	Projected Fall Snapshot Enrollment <i>DRAFT</i>									
	2020/21	2021/22	2022/23	2023/24	2024/25	2025/26	2026/27	2027/28	2028/29	2029/30	2030/31
<b>Baxter Elementary</b>	<b>Campus Capacity = 750</b>										
Total Enrollment	532	539	553	587	633	668	723	773	823	861	884
Capacity Utilization	71%	72%	74%	78%	84%	89%	96%	103%	110%	115%	118%
Space Remaining	218	211	197	163	117	82	27	-23	-73	-111	-134
<b>Irvin Elementary</b>	<b>Campus Capacity = 750</b>										
Total Enrollment	624	637	680	700	710	725	727	728	731	732	734
Capacity Utilization	83%	85%	91%	93%	95%	97%	97%	97%	97%	98%	98%
Space Remaining	126	113	70	50	40	25	23	22	19	18	16
<b>Longbranch Elementary</b>	<b>Campus Capacity = 750</b>										
Total Enrollment	547	527	553	580	615	675	737	792	858	921	967
Capacity Utilization	73%	70%	74%	77%	82%	90%	98%	106%	114%	123%	129%
Space Remaining	203	223	197	170	135	75	13	-42	-108	-171	-217
<b>Miller Elementary</b>	<b>Campus Capacity = 750</b>										
Total Enrollment	707	680	677	659	662	657	676	694	706	712	718
Capacity Utilization	94%	91%	90%	88%	88%	88%	90%	93%	94%	95%	96%
Space Remaining	43	70	73	91	88	93	74	56	44	38	32
<b>Mt. Peak Elementary</b>	<b>Campus Capacity = 750</b>										
Total Enrollment	629	622	661	701	727	734	760	784	811	838	863
Capacity Utilization	84%	83%	88%	94%	97%	98%	101%	104%	108%	112%	115%
Space Remaining	121	128	89	49	23	16	-10	-34	-61	-88	-113
<b>Vitovsky Elementary</b>	<b>Campus Capacity = 750</b>										
Total Enrollment	593	594	695	773	844	955	1,076	1,176	1,315	1,467	1,625
Capacity Utilization	79%	79%	93%	103%	113%	127%	143%	157%	175%	196%	217%
Space Remaining	157	156	55	-23	-94	-205	-326	-426	-565	-717	-875
<b>McClatchey Elementary</b>	<b>Campus Capacity = 750</b>										
Total Enrollment	657	628	614	608	601	617	632	648	661	672	674
Capacity Utilization	88%	84%	82%	81%	80%	82%	84%	86%	88%	90%	90%
Space Remaining	93	122	136	142	149	133	118	102	89	78	76
<b>Elementary Totals</b>	<b>Total Elementary Capacity = 5,250</b>										
Total Enrollment	4,289	4,227	4,433	4,608	4,792	5,032	5,330	5,595	5,905	6,204	6,465
Capacity Utilization	82%	81%	84%	88%	91%	96%	102%	107%	112%	118%	123%
Space Remaining	961	1,023	817	642	458	218	-80	-345	-655	-954	-1,215

Proposed additional capacity between 2022 and 2023

# MIDDLE AND HIGH SCHOOL CAMPUS PROJECTIONS VS. CAPACITY



Midlothian ISD - Campus Projections (Moderate Scenario)	Historical	Projected Fall Snapshot Enrollment <b>DRAFT</b>									
	2020/21	2021/22	2022/23	2023/24	2024/25	2025/26	2026/27	2027/28	2028/29	2029/30	2030/31
<b>Frank Seale Middle</b>		<b>Campus Capacity = 1,200</b>									
Total Enrollment	676	723	757	774	838	908	975	1,006	1,065	1,108	1,156
Capacity Utilization	56%	60%	63%	64%	70%	76%	81%	84%	89%	92%	96%
Space Remaining	524	477	443	426	362	292	225	194	135	92	44
<b>Walnut Grove Middle</b>		<b>Campus Capacity = 1,200</b>									
Total Enrollment	1,021	1,028	1,018	1,021	1,030	1,062	1,103	1,122	1,165	1,215	1,254
Capacity Utilization	85%	86%	85%	85%	86%	89%	92%	94%	97%	101%	104%
Space Remaining	179	172	182	179	170	138	97	78	35	-15	-54
<b>Dieterich Middle</b>		<b>Campus Capacity = 1,200</b>									
Total Enrollment	750	798	741	757	739	775	766	760	722	720	729
Capacity Utilization	63%	67%	62%	63%	62%	65%	64%	63%	60%	60%	61%
Space Remaining	450	402	459	443	461	425	434	440	478	480	471
<b>Middle School Totals</b>		<b>Total Middle School Capacity = 3,600 (w/ Addition of Dieterich MS in 2020)</b>									
Total Enrollment	2,447	2,550	2,517	2,551	2,607	2,745	2,844	2,888	2,952	3,044	3,139
Capacity Utilization	68%	71%	70%	71%	72%	76%	79%	80%	82%	85%	87%
Space Remaining	1,153	1,050	1,083	1,049	993	855	756	712	648	556	461
<b>Heritage High</b>		<b>Campus Capacity = 1,100</b>				<b>Campus Capacity w/ Fall Expansion = 2,500</b>					
Total Enrollment	1,098	1,169	1,265	1,308	1,332	1,332	1,316	1,361	1,374	1,409	1,458
Capacity Utilization	100%	106%	115%	52%	53%	53%	53%	54%	55%	56%	58%
Space Remaining	2	-69	1,235	1,192	1,168	1,168	1,184	1,139	1,126	1,091	1,042
<b>Midlothian High</b>		<b>Campus Capacity = 2,500</b>									
Total Enrollment	2,015	2,095	2,249	2,346	2,505	2,551	2,601	2,696	2,768	2,875	2,946
Capacity Utilization	81%	84%	90%	94%	100%	102%	104%	108%	111%	115%	118%
Space Remaining	485	405	251	154	-5	-51	-101	-196	-268	-375	-446
<b>High School Totals</b>		<b>Total High School Capacity = 3,600</b>				<b>Total High School Capacity w/ Heritage Expansion = 5,000</b>					
Total Enrollment	3,113	3,264	3,514	3,654	3,837	3,883	3,917	4,058	4,141	4,285	4,403
Capacity Utilization	86%	91%	98%	73%	77%	78%	78%	81%	83%	86%	88%
Space Remaining	487	336	1,486	1,346	1,163	1,117	1,083	942	859	715	597
<b>District Totals (PK-12)</b>		<b>Total District Capacity = 12,450 (w/ MS#3)</b>				<b>Total District Capacity w/Heritage Expansion = 13,850</b>					
Total Enrollment	9,849	10,042	10,464	10,813	11,236	11,660	12,092	12,540	12,998	13,532	14,008
Capacity Utilization	79%	81%	84%	78%	81%	84%	87%	91%	94%	98%	101%
Space Remaining	2,601	2,408	3,386	3,037	2,614	2,190	1,758	1,310	852	318	-158
<b>OVER 100% OF CAMPUS CAPACITY</b>											
Annual Chg.	57	193	423	348	423	424	431	449	458	534	475
% Growth	0.6%	2.0%	4.2%	3.3%	3.9%	3.8%	3.7%	3.7%	3.7%	4.1%	3.5%

Additional capacity added in 2020 at the MS level and more coming in 2022 at the HS level

# Midlothian ISD

## 4Q 2020 Demographics Summary

- Enrollment growth continues to be driven by a surging new home market
- MISD see record new home construction in the 4<sup>th</sup> quarter of 2020: 368 starts & 233 closings
- The annual starts rate for new homes climbs to a record high in 2020 with 944 starts
- 684 new homes were occupied (closings); +10% YoY
- District's median new home price now stands at \$360,211 (+4.3% YoY)
- Developers delivered a record, 1,176 new single-family (SF) lots in MISD in 2020 plus 152 new apartments
- 1,530 vacant SF lots were remaining at the end of December 2020
- 1,434 future SF lots are currently under development in the district
- Developers are planning an additional 13,000+ future SF lots
- Combined there are currently 16,800 single-family lots in-process/planned in the district
- MISD could see nearly 5,000 new homes occupied over the next 5 years and 9,700 homes by Fall 2030
- Active new home subdivisions in MISD are currently yielding 0.64 enrolled students per home
- 363 future apartment units are currently in-process/planned in the district
- Apartments in MISD are currently yielding 0.26 enrolled students per unit
- Residential construction and development projected to drive MISD enrollment growth up by an average of 3.4% annually over the next 5 years, but with the uncertainty of the current COVID-19 environment, district enrollment will likely remain in the 9,900-10,500 student range over the next two years
- MISD enrollment could surpass 11,000 students by 2024 and 13,000 students by 2028 if growth returns to the 3-4% annual rate



16980 Dallas Parkway  
Suite 101  
Dallas, Texas 75248

[www.schooldistrictstrategies.com](http://www.schooldistrictstrategies.com)

Although School District Strategies (SDS) has used commercially reasonable efforts to obtain information from sources it believes to be reliable and accurate, SDS does not guarantee the accuracy or completeness of such information. Information presented in this report represents SDS's estimates as of the date of the report and is subject to change without notice. This report is not intended as a recommendation or endorsement of any action taken by you or any third party in regard to the subject matter of this report or any other real estate activity. SDS WILL HAVE NO LIABILITY FOR INDIRECT, INCIDENTAL, CONSEQUENTIAL, OR SPECIAL DAMAGES, INCLUDING (BUT NOT LIMITED TO) LOST PROFITS, OR DIMINUTION IN VALUE OF YOUR BUSINESS OR PROPERTY, ARISING FROM OR RELATING TO SDS'S SERVICES HEREUNDER, REGARDLESS OF ANY NOTICE OF THE POSSIBILITY OF SUCH DAMAGES AND WHETHER OR NOT SUCH DAMAGES ARE REASONABLE OR FORESEEABLE UNDER THE APPLICABLE CIRCUMSTANCES. SDS'S LIABILITY ON ANY CLAIM OF ANY KIND, INCLUDING NEGLIGENCE, FOR ANY LOSS OR DAMAGE ARISING OUT OF, CONNECTED WITH, OR RESULTING FROM THIS REPORT OR THE SERVICES PROVIDED BY SDS SHALL IN NO SINGLE CASE, OR IN THE AGGREGATE, EXCEED THE AMOUNTS ACTUALLY PAID TO SDS IN CONNECTION WITH THE REPORT.

The following contingencies and limiting conditions are noted as fundamental assumptions that may affect the accuracy or validity of the analysis and conclusions set forth in this report. Specifically, the parties assume: that the Dallas/Fort Worth metropolitan area, the State of Texas, and the nation as a whole will not suffer any major economic shock during the time period of the forecast contained in this report; that general population levels will continue to increase at or above the rate forecast; that the public and third party sources of statistical data and estimates used in this analysis are accurate and complete in all material respects, and that such information is a reasonable resource for project planning purposes; the proposed real estate development projects described herein, when completed, will be designed, promoted, and managed in a manner that will have an impact on the local market that is reasonably consistent with other similar projects in the past; and that the recommendations set forth in this report will be acted upon within a reasonable period of time to preclude major changes in the factual conditions evaluated.

Copyright 2021 School District Strategies.

**Midlothian I.S.D. School Board Agenda Item Detail**  
**L.A. Mills Administrative Complex Boardroom**

<b>Board Meeting Date:</b>	<b>April 19, 2021</b>	
<b>Item:</b>	<b>Community Committee Boundary Recommendation</b>	
<b>Supporting Document(s):</b>	Electronic: Yes <input checked="" type="checkbox"/> No <input type="checkbox"/>	Hard Copy: Yes <input type="checkbox"/> No <input checked="" type="checkbox"/>
<b>Background Information:</b>	<p>As MISD prepares to open Elementary School #8 and Heritage High School Phase 2, reviewing and recommending new school boundaries are necessary. To take a proactive and holistic approach, the district administration convened a community committee to review the latest demographer and housing information and make recommendations for elementary and high school boundaries, as well as re-evaluate middle school boundaries, as needed.</p> <p>Using the below parameters, the committee used this as a filter in making the best recommendation possible.</p> <p><b>Board-approved Parameters:</b></p> <ul style="list-style-type: none"> <li>● Balance enrollment across MISD</li> <li>● Keep neighborhoods/subdivisions in tact</li> <li>● Leverage natural boundaries as much as possible</li> <li>● Review/follow district policy on grandfathering options</li> </ul> <p>The committee sought input in March, met to review input to determine whether modifications could be made. After reviewing input and meeting with the demographer, the committee is bringing forward final recommendations for discussion and action for the MISD Board of Trustees.</p>	
<b>Fiscal Impact/Budget Function Code:</b>	N/A	
<b>Policy:</b>	N/A	
<b>District Goal:</b>	Build a strong foundation of the MISD culture through communication and engagement to empower all stakeholders.	
<b>Administration Recommended Option:</b>	N/A	
<b>Motion:</b>	Discussion & Action	
<b>Presenter:</b>	Karen Fitzgerald, Assistant Superintendent Valerie Boyd, Sabrina Michaels, Eduardo Gonzalez, Steve Pena	



# School Boundary Update & Final Recommendation

---

April 19, 2021

Valerie Boyd  
Sabrina Micheals  
Eduardo Gonzalez  
Steven Pena

# Agenda:

- Review of Process
- Community Input Feedback
- Committee Input Review & Recommendation Rationale
- Final Recommendation



# Purpose of Process:

Convene a community committee comprised of parents, staff and students to review and provide recommendations for elementary, possible modifications to middle school and newly defined high school zones.

## Board-Directed Parameters:

- Balance enrollment across MISD
- Keep neighborhoods/subdivisions in tact
- Leverage natural boundaries as much as possible
- Review/follow district policy on grandfathering options



# Timeline:

- October 19, 2020 - Board information on MISD school boundary purpose & process
- November 16, 2020 - Board action and communication to community regarding process and opportunity to serve.
- December 7&8, 2020 - Pull names and contact participants; Email participants with roles/responsibilities/meeting times & dates
- January 6, 13, 20, 27, 2021 - Committee Meetings from 5:30-7 p.m.
- January 19, 2021 - Board Information/Committee Update
- February 3&10, 2021 - Committee Meetings from 5:30-7 p.m.
- **February 15, 2021** - Board presentation on recommendations
- **February 23-25, 2021** - Community Information evening & lunch sessions
  - ***Newly proposed dates March 3&4***
- **March 3&4, 2021** - Committee Meet to review input & make adjustments as necessary
  - ***Newly proposed dates March 10&24***
- **March 24, 2021** - Committee met with demographer and made final recommendations.
- **April 19, 2021** - Committee to present to Board of Trustees



# Community Committee Process:

- Community Committee Process
- Committee size: 25+ participants
- Establish a Committee member matrix:
  - 3 representatives from each elementary zone
    - 2 Representatives from larger subdivisions
    - 1 Representative from rural areas/smaller subdivisions
  - Principals, Athletic and Fine Art Coordinators
  - Participation by nomination & lottery selection
- Committee member roles are all at-large



# Meet the Committee:

Elizabeth Holleman  
Laura Stratton  
Clark Manor  
Jessica Diaz  
Steven Pena  
Kimberly Norman  
Jessica Frazier  
David Bostwick  
Tara Kemp  
Angela Marcum  
Suzanne Wyatt  
Valerie Boyd  
Amanda Fabish

Sabrina Michaels  
Eduardo Gonzalez  
Kevin Bachinski  
Colten Keele  
Dusty Lee Marks  
Todd York  
Doug Wendel  
Lee Wiginton  
Dr. Aaron Williams  
Krista Tipton  
Carolyn Spain  
Amanda Rodgers  
Hollye Walker

ExOfficio:  
Dr. Courtney Carpenter  
Jim Norris  
KayLynn Day  
Leslie Garkani  
Brian Blackwell  
Facilitator: Karen Fitzgerald



# Team Norms:

*Team norms are a set of rules or operating principles that shape team members' interactions. Team norms establish clear, agreed-upon behavior, how the work will get done, and what team members can expect of each other.*

- Engage - Fully participate by sharing thoughts and listening to each perspective
- Collaborate - Work together to find the best solution
- Mute cell phones - Take our calls outside the meeting area
- Attendance - It's needed!
- Big picture - Make decisions on what is best for the whole district





# Community Input Results

---

# Input Results

*Approximately out of 10,000 families*

- **3.8% participated in ThoughtExchange**

- **.07% In-Person**

- **.18% Emails**

Can you support this recommendation?



%	Person Icon	Answer
66%	(170)	■ Yes
34%	(88)	■ No



# Review of Options

---

## Elementary Options:

- Reviewed 3 options
- Selected this option that best fit Board parameters
- Achieves balance
- Establishes a strong boundary to support growth for the next six years
- Minimizes campus splits to the best of our ability from elementary to middle school
- Continues to lay the foundation for a feeder system



# Elementary School Option - ORIGINAL & FINAL RECOMMENDATION

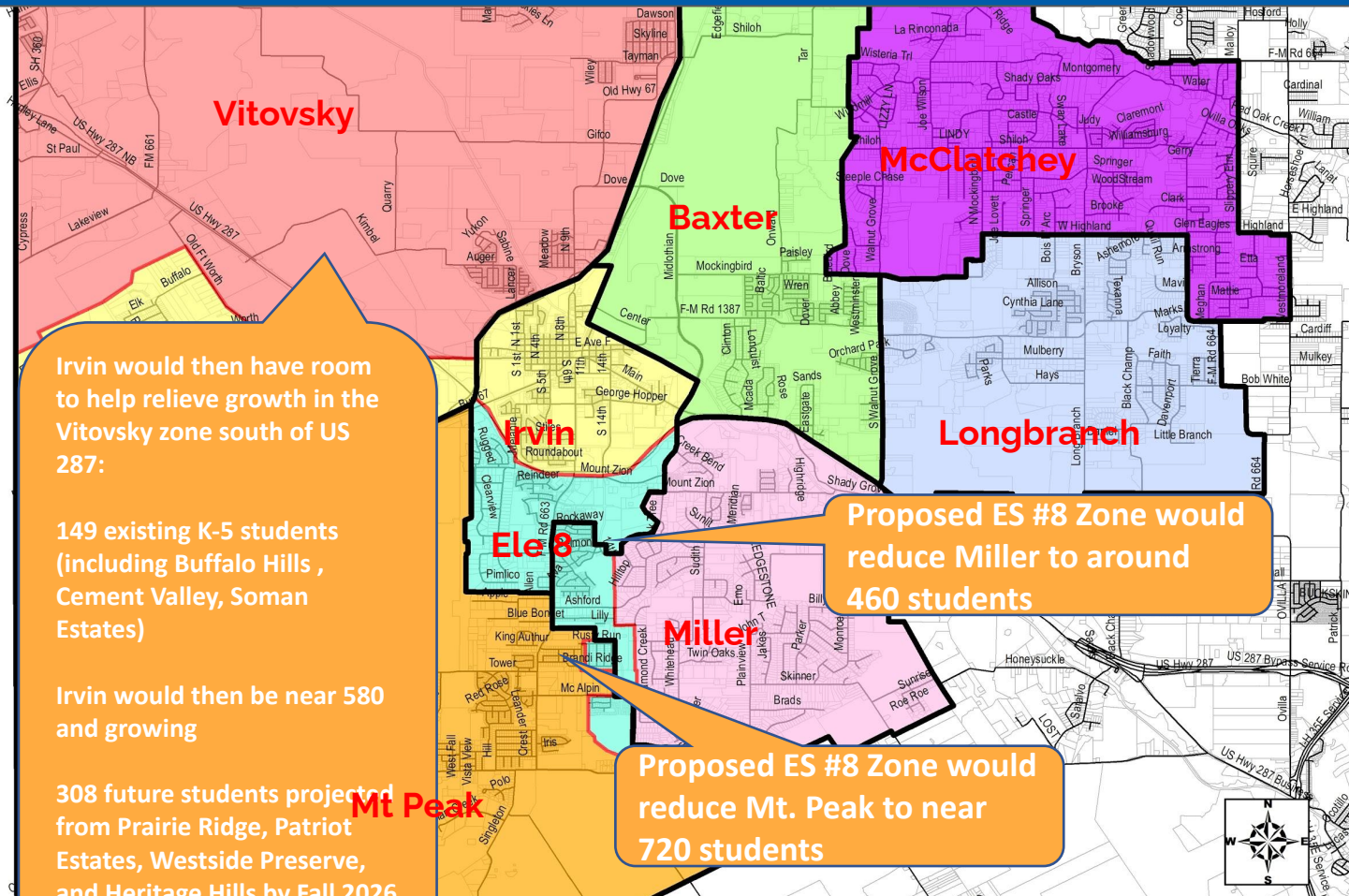

Irvin would then have room to help relieve growth in the Vitovsky zone south of US 287:

149 existing K-5 students (including Buffalo Hills, Cement Valley, Soman Estates)

Irvin would then be near 580 and growing

308 future students projected from Prairie Ridge, Patriot Estates, Westside Preserve, and Heritage Hills by Fall 2026

Proposed ES #8 Zone would reduce Miller to around 460 students

Proposed ES #8 Zone would reduce Mt. Peak to near 720 students

**Mt Peak**



# Middle School Options

---

# Middle School Options based on Feedback:

- Overall, drafted and reviewed 4 of middle school options.
- Based on community input, drafted and reviewed additional options.
- Feedback primarily within a portion of Baxter school zone
- Based on feedback and options addressing the feedback:
  - **The Positives**
    - Modified boundary based on parent feedback in one area
  - **The Concerns**
    - Provide transportation inefficiency
    - Created additional elementary campus split (Longbranch Elementary; two splits would occur Baxter & Longbranch and we wanted to minimize splits)



# Middle School Option based on community input

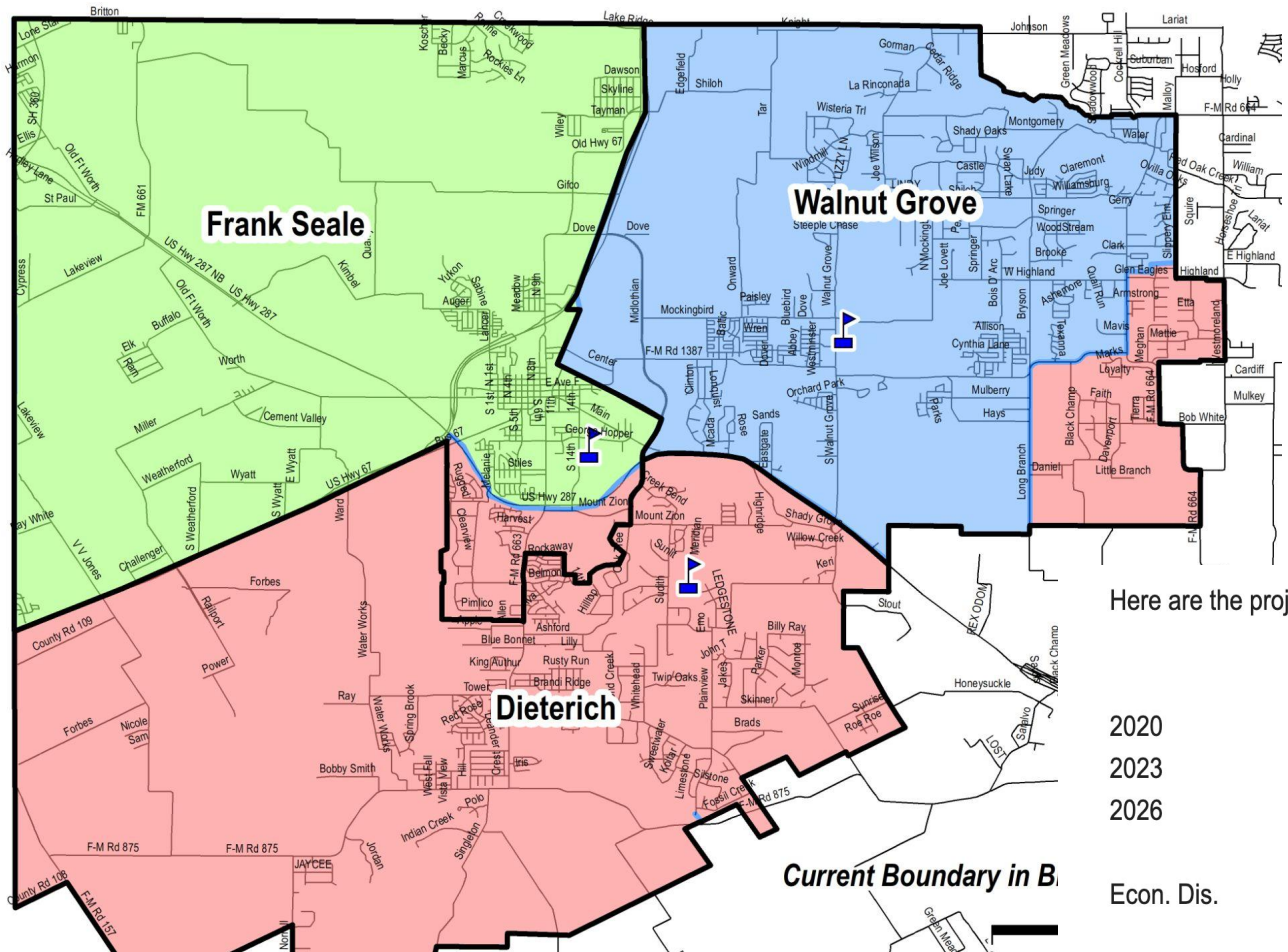

Here are the projected numbers:

	<b>FSMS</b>	<b>WGMS</b>	<b>DMS</b>
2020	676	1,021	750
2023	680	865	1,029
2026	862	967	1,046
Econ. Dis.	49%	17%	17%

# Middle School Recommendation Rationale cont'd:

## Feeder Foundation:

- Middle school boundaries are based on the proposed ES #8 map
- Feeder approach:
  - **FSMS:** Irvin and Vitovsky
  - **WGMS:** Baxter, McClatchey, and Longbranch feed into WGMS (*as they do currently and continues with that feeder foundation*) but with the requested change in the southeast corner. That area would go to DMS, so 5<sup>th</sup> graders in that area would come from both Longbranch and McClatchey.
  - **DMS:** Mt. Peak, Miller and Ele #8
- Overall, it's an average of 43, 5<sup>th</sup> graders per year (wouldn't go to WGMS).



# Middle School Option - ORIGINAL & FINAL RECOMMENDATION

**DRAFT**

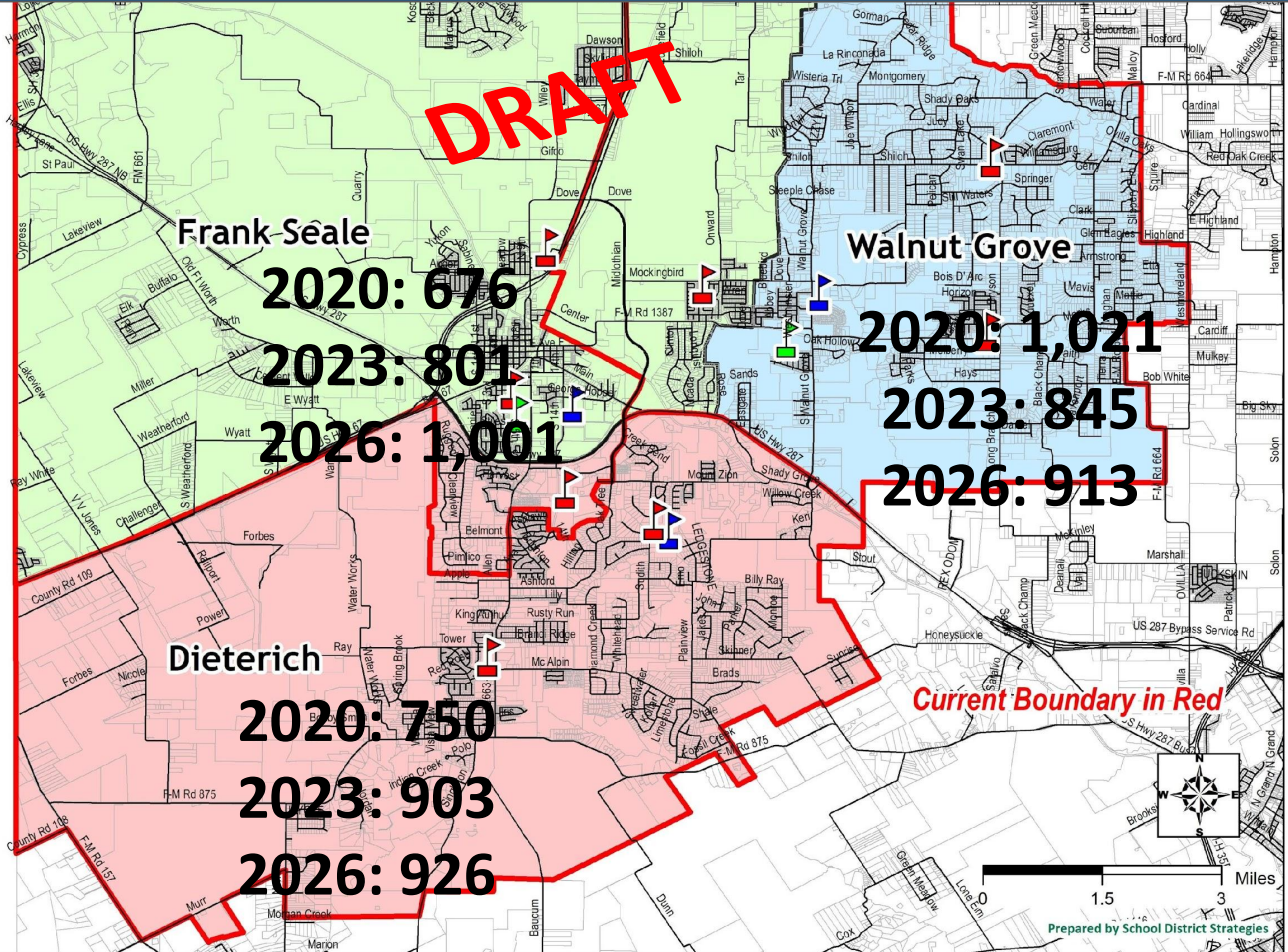

**Frank-Seale**  
 2020: 676  
 2023: 801  
 2026: 1,001

**Dieterich**  
 2020: 750  
 2023: 903  
 2026: 926

**Walnut Grove**  
 2020: 1,021  
 2023: 845  
 2026: 913

*Current Boundary in Red*

Economically Disadvantaged:  
 Walnut Grove 14.5%  
 Frank Seale 43.8%  
 Dieterich 18.6%  
*Current 6-8th Graders*



# High School Options

# High School Options based on community input:

- In total, reviewed 5 different options
- Based on community and Board input, re-reviewed the other options.
- The pros and cons of these additional options:
  - **Positives:**
    - addressed community input that directly impacted those who shared concerns
  - **Concerns:**
    - created unbalance of enrollment and economics
    - UIL programs negatively impacted creating competitive disparity between campuses,
    - May not be sustainable for six years due to growth





# Additional High School Option Explored: OPTION #5

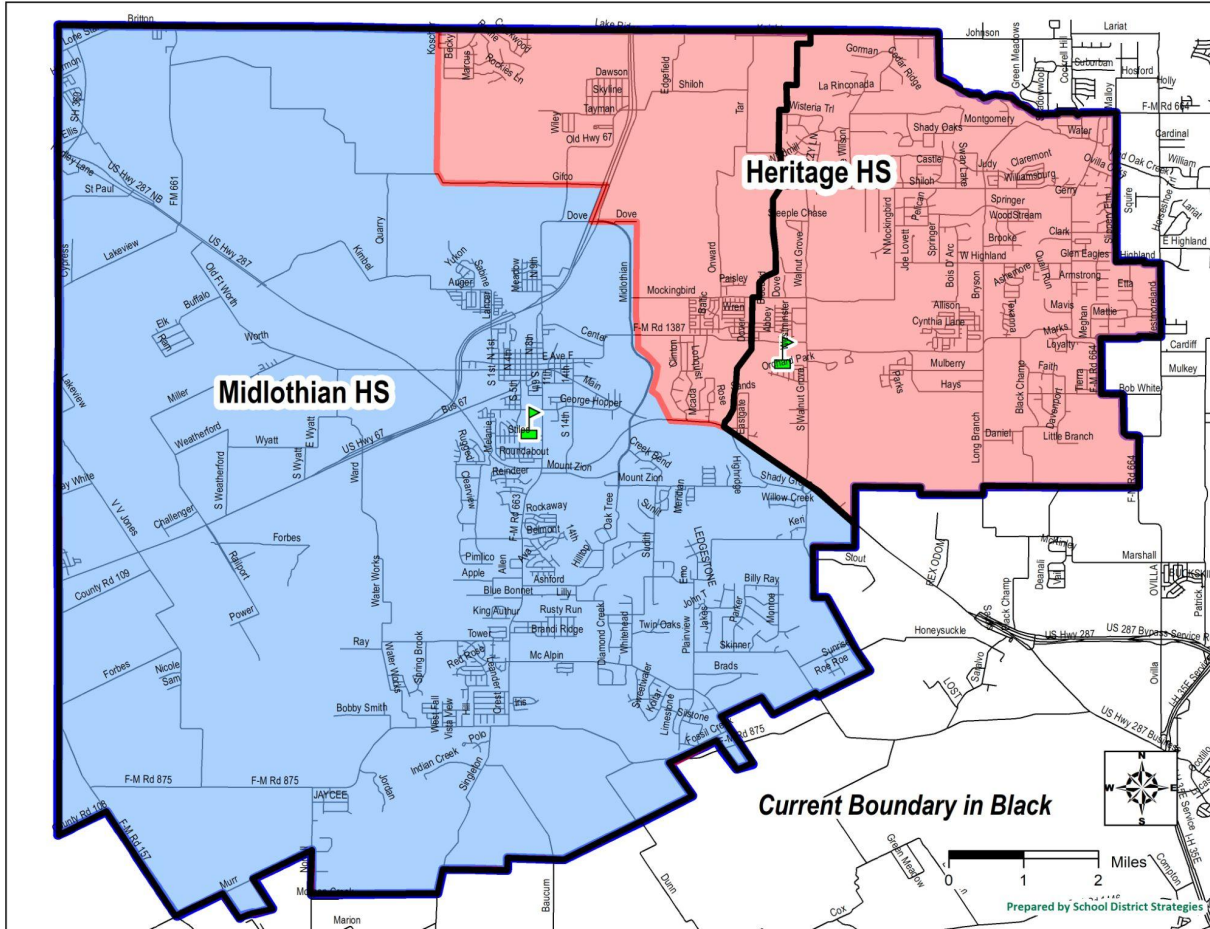

If Millbrook, Overlook, Village South and the apartment neighborhoods around JAV stay in MHS and the boundary includes Dove Rd/Midlothian Pkwy, then about 194 students would not move to Heritage.

Here are the numbers:

	<u>HHS</u>	<u>MHS</u>
2020	1,098	2,015
2023	1,606	2,047
2026	1,661	2,252
	16.7% Eco Dis	28.5% Eco Dis

# High School Recommendation Rationale:

- Selected Option 3 that best fit aligned to Board parameters and achieves socio-economic balance
- Established a strong boundary to support growth for the next six years
- Analyzed fine arts, athletics and other student programs for growth and campus moral at both high schools
- Aligns with the elementary and middle school boundaries



# High School Option #3 - ORIGINAL & FINAL RECOMMENDATION

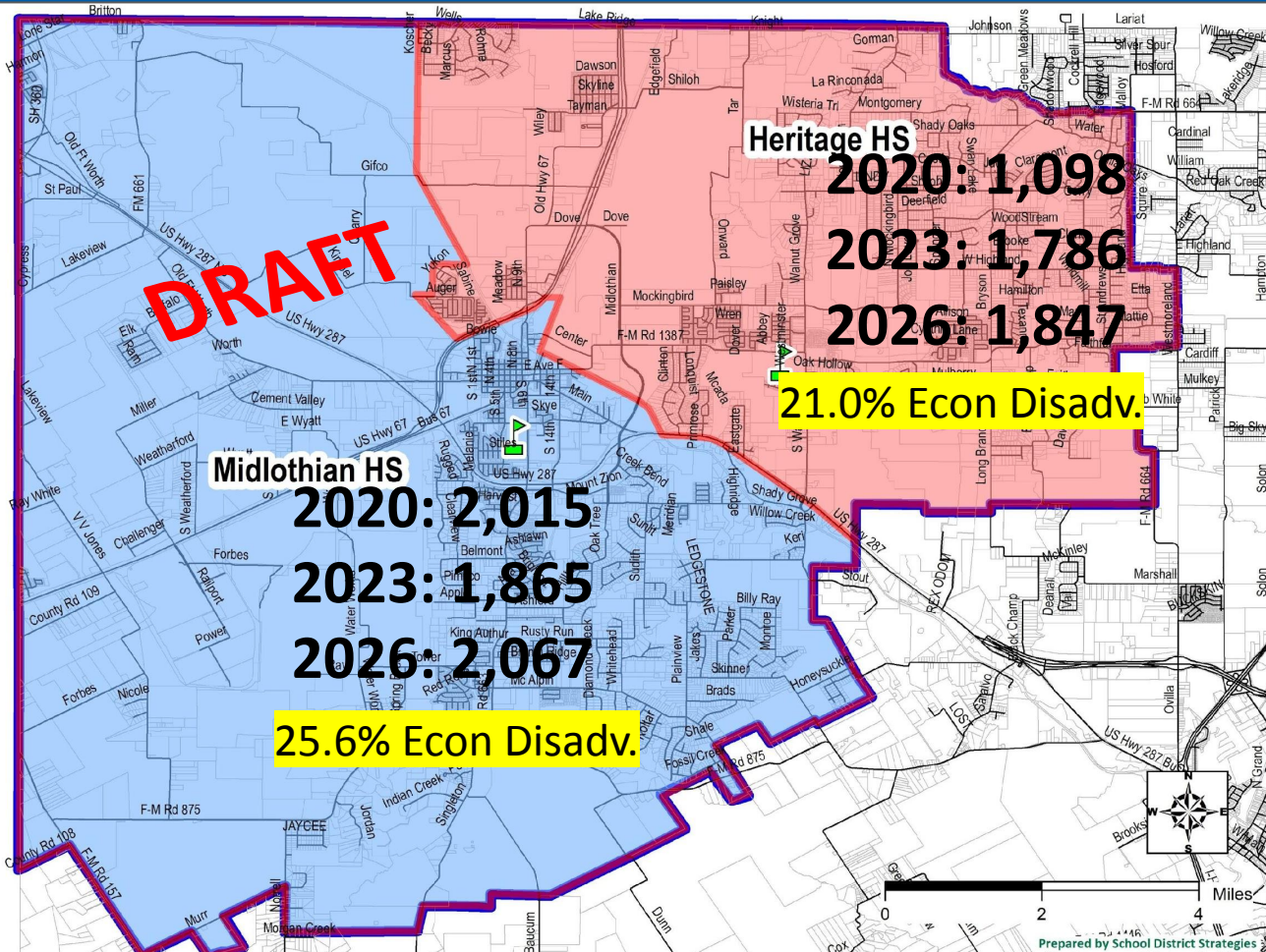



# 3 Final Options: Creating a holistic approach

---

# Elementary

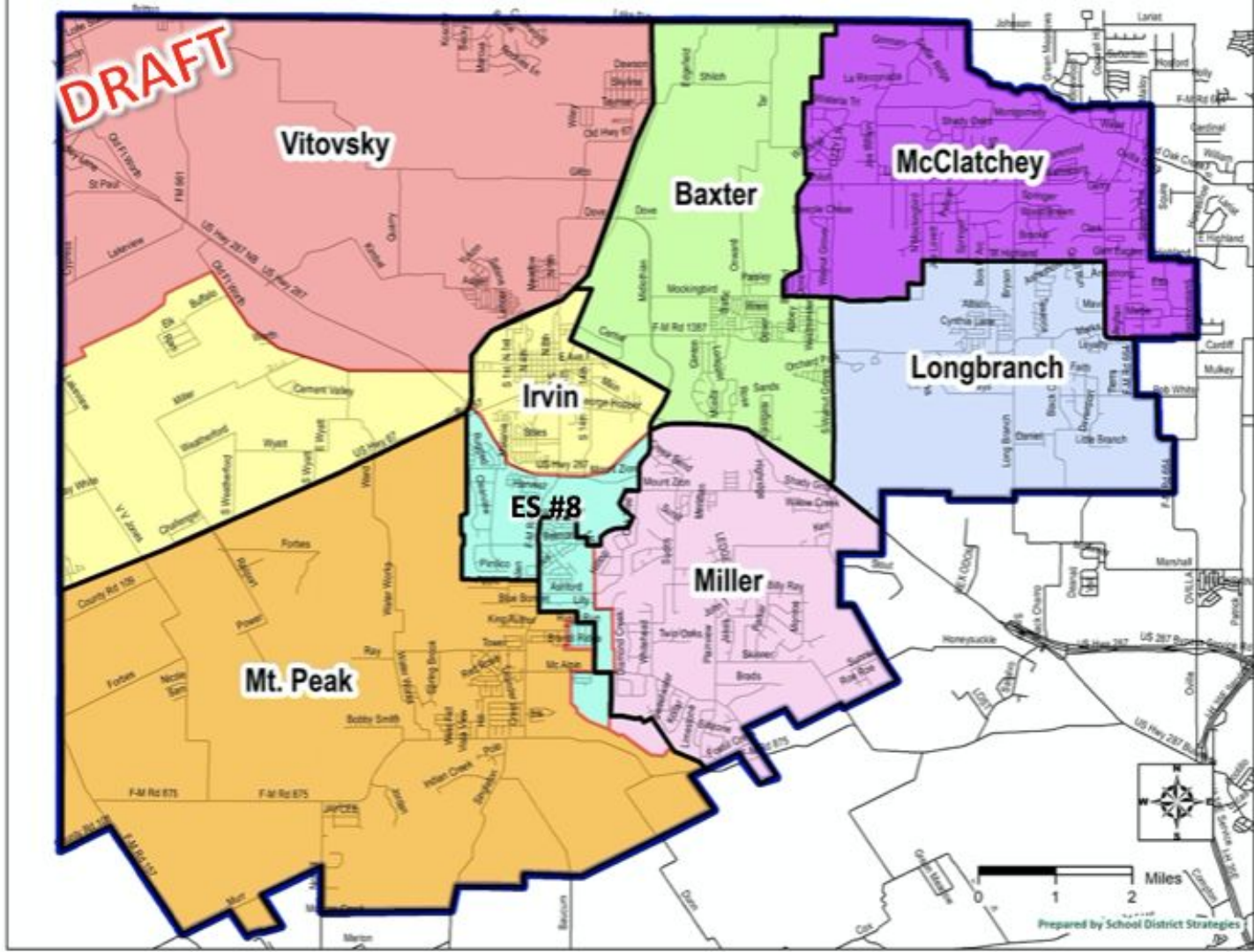

# Proposed Middle School Boundaries

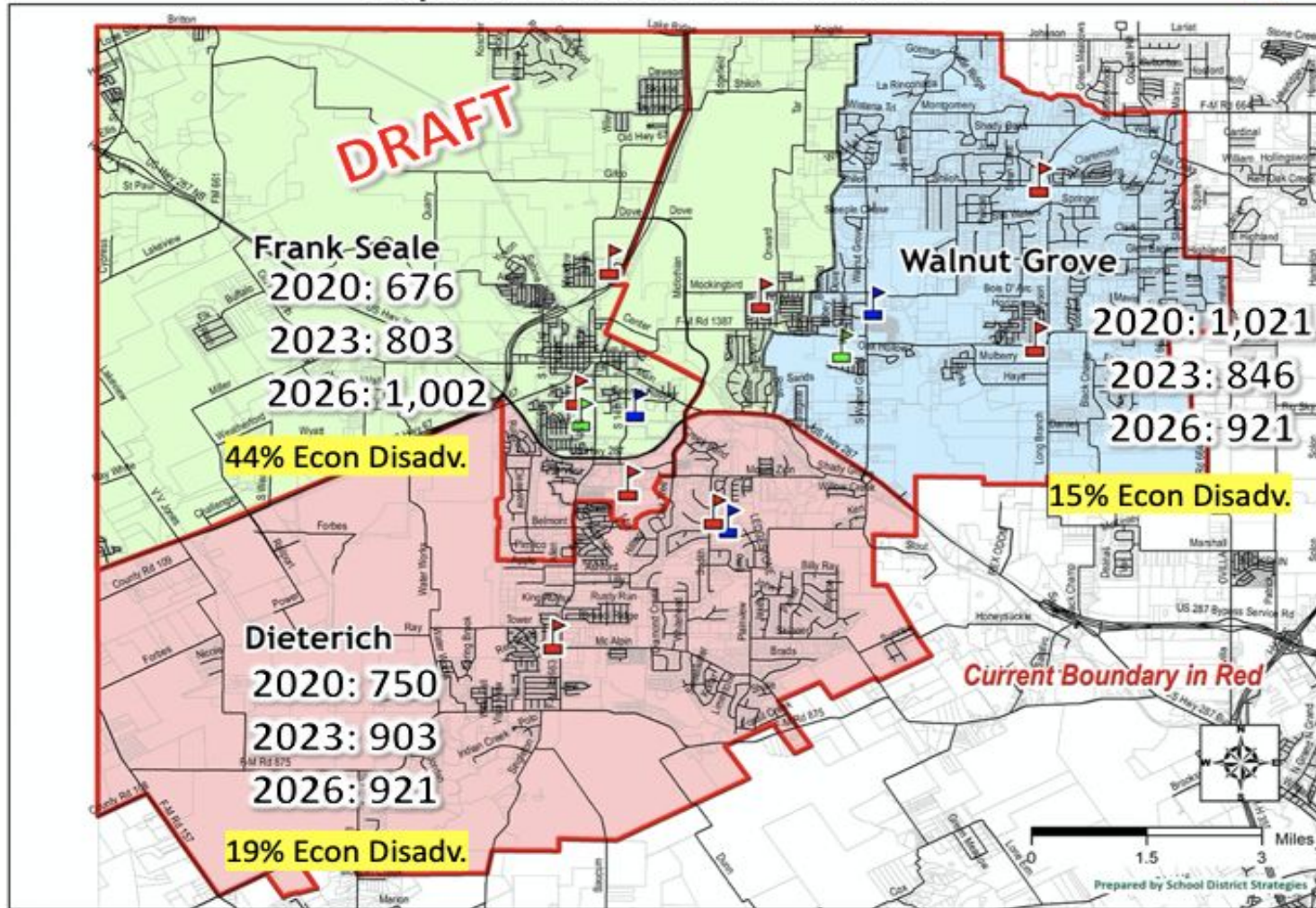

# Proposed Fall 2022 High School Zones - Option 3

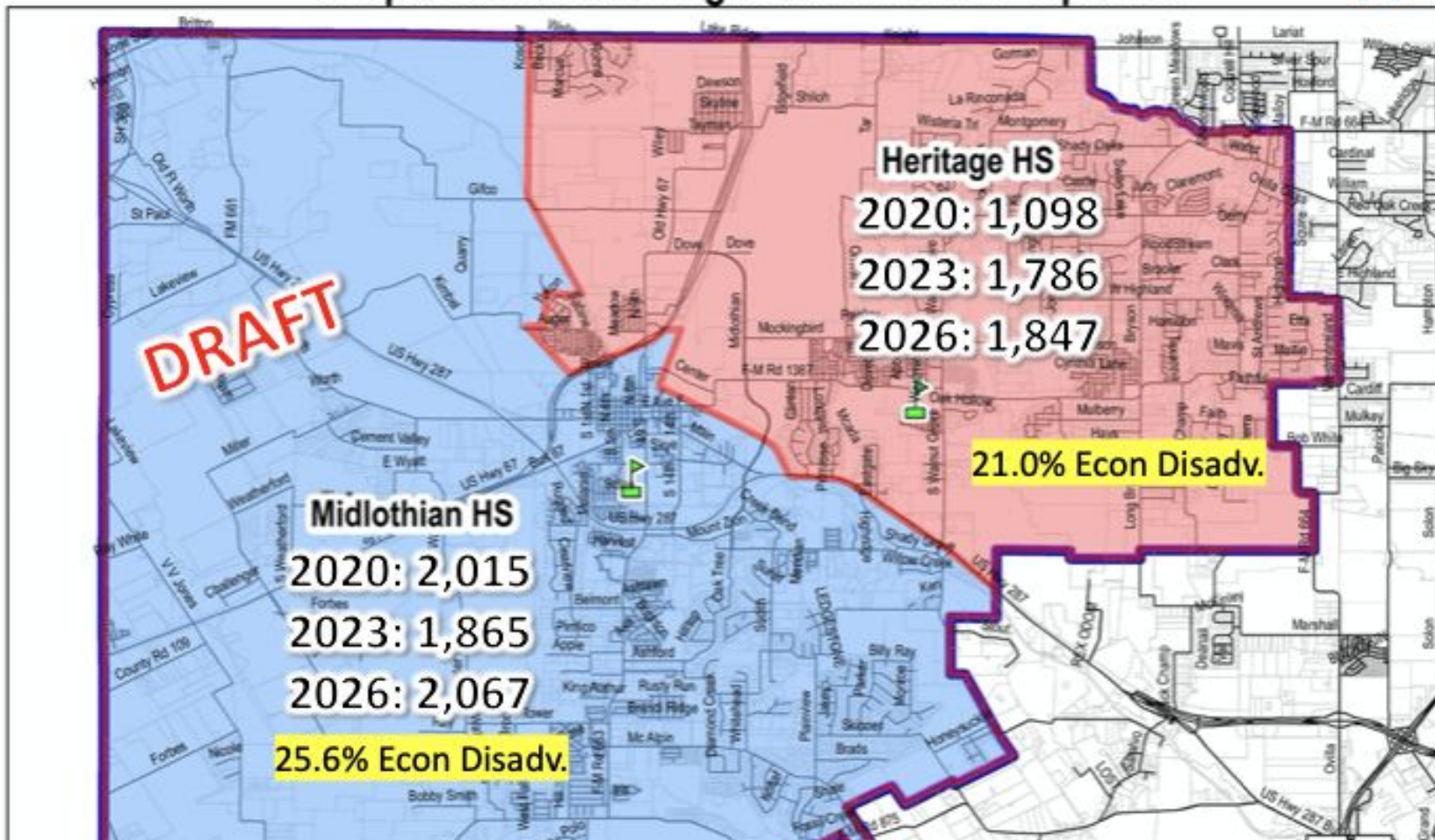

## **Committee Recommendation:**

*Committee recommendation is to approve the elementary, middle and high school boundaries as proposed. These proposed boundaries align to the Board parameters along with the community committee's desire to continue with the concept of establishing a foundational feeder pattern for campuses.*





NAMING FACILITIES

CW  
(LOCAL)

**Guidelines**

The following guidelines shall be used in the naming of school buildings:

1. Facilities may be named for persons who have served the District or community, especially in service to children.
2. Facilities may be named for any local, state, or national heroic figure.
3. The individual may be living or deceased.
4. A nominee shall have made a significant contribution to society and/or education, and his or her name shall lend prestige and status to an institution of learning.
5. The individual must represent exemplary human qualities that can serve as a model of excellence for the students who will attend the school.
6. Facilities may be named for local residential or geographic areas or state or national landmarks.
7. A request for proposal (RFP) process may be used to provide naming rights to an athletic or special use facility.

Exceptions

Facilities may be named using committee recommendations that do not follow the guidelines at items 1, 2, or 6, above.

Committee

With the exception of a request for proposal process, solicitation of recommendations of names shall be conducted through a committee composed of the following representatives:

1. One campus employee who resides within the District and who has been elected by the employees at each campus.
2. Two community representatives who reside within the District, and are not District employees, and have been selected by the District-wide Educational Improvement Council (DEIC). [See BQA]
3. Two parent representatives who reside within the District, are not District employees, and have been selected by the DEIC.

The committee shall be chaired by the Superintendent or designee. The committee shall submit to the Board no fewer than five and no more than ten recommended names for each campus or facility to be named.

Nominations

Nominations shall be submitted to the Board through the Superintendent. The supporting data shall include a succinct description of the nominee's contributions, why they are important, and any pertinent history that should be considered. No more than three pages

NAMING FACILITIES

CW  
(LOCAL)

of supporting documentation shall be included for each nomination. The Board shall not consider petitions.

**Request for Proposal Option**

The Board may utilize the request for proposal option to name an athletic or special use school facility. When using the RFP option, all standard bidding procedures shall be followed in accordance with Education Code 44.031. A recommendation shall be made by the Superintendent to the Board based upon proposals received.

Time Frame

The Superintendent shall announce a time period for receipt of written nominations. This time period shall be for approximately three months and shall occur at a time that will permit the Board to deliberate on the nominations and make a selection prior to the opening of the new school or facility.

For the RFP option, standard bidding requirement time frames shall be followed.

**Board Decision**

The responsibility for the final decision in naming facilities shall rest with the Board. At a regularly scheduled meeting, the Board may:

- Select a name from the list of recommendations submitted by the committee for each campus or facility to be named;
- Direct the same committee or a new committee to submit a new list of recommended names;
- Choose a name other than the names recommended by the committee; or
- Select a proposal from the RFP procedure.

**Midlothian I.S.D. School Board Agenda Item Detail**  
**L.A. Mills Administrative Complex Boardroom**

<b>Board Meeting Date:</b>	<b>April 19, 2021</b>	
<b>Item:</b>	<b>COVID Update</b>	
<b>Supporting Document(s):</b>	Electronic: Yes <input checked="" type="checkbox"/> No <input type="checkbox"/>	Hard Copy: Yes <input type="checkbox"/> No <input checked="" type="checkbox"/>
<b>Background Information:</b>	<p>COVID Public Health Update:</p> <p>Current COVID update, year in review, and next steps.</p>	
<b>Fiscal Impact/Budget Function Code:</b>	N/A	
<b>Policy:</b>	N/A	
<b>District Goal:</b>	Provide a safe and secure learning environment that supports the social and emotional well-being of our school community.	
<b>Administration Recommended Option:</b>	The District is not recommending action at this time.	
<b>Motion:</b>	A motion is only needed if there is a desire to change the current TEA and District masks protocols.	
<b>Presenter:</b>	Shorr Heathcote	



# COVID Update for Board of Trustees

---

April 19, 2021

# COVID Updates - April 19, 2021

- **Year in Review**
- **Quarantine and Protocol Updates**
- **Mask Survey Data**
  - Parents
  - Staff
- **Vaccinations**
  - Staff



# Historical Information

- **April 2020:** Reentry Task Force began working on a plan for the 2020-2021 school year (*over 85 individuals: staff, parents, community, medical professionals, and student voice*)
- **July 20, 2020:** School Reopening Plan Presented to Board of Trustees Based on Governor's Executive Order, TEA Guidance & Local Health Authority Guidance. Plan approved on July 27th by Board of Trustees to include mandated masks for Kinder-12th grade, following standards set by TEA and additional guidance by our Local Health Authority.
- **August-September 2020:** School began virtually for 3 weeks (Board Approved) and F2F learning was phased in to allow time for students and staff to acclimate to safety and mitigation efforts. ***Mask exception protocol*** developed and communicated with campuses. (recess, lunch, strenuous activity, etc.)



# Historical Information

- **October 2020:** COVID Screening, Protocols and internal tracking of staff and student cases and how the District monitors Close Contacts
- **November 2020:** Tiered system established to determine when to close an activity. Automatically transition students to VL when they have been in Close Contact.
- **December 2020:** Board Approved - Modified the Dual Platform of Learning Plan for Virtual Qualifying Students (*grade and attendance requirements*)
- **January 2021:** Board Approved - Modified Calendar for Asynchronous Instruction for teacher planning and preparation.



# Historical Information

- **March 2021:**
  - Governor's Executive Order GA-34 Issued, removing a state-wide mask mandate, giving the Texas Education Agency authority to provide operation guidelines to school (#6 GA-34).
  - Texas Education Agency provided updated Public Health Guidance to schools in Texas, continuing the requirement of masks for staff and students ages 10 and up. District consulted with local health authority & task force medical representative.
  - MISD continued PK-12 mask requirements.
  - Board update on staff vaccinations 15% fully vaccinated and Mask Options Considered
  - Quarantine Timeline Revised - Reduced to 10 days
  - Virtual Learning Qualifications Revisited for 6th Six Weeks



# Historical Information

- **April 2021**

- MISD continues tracking COVID cases and quarantines from close contact
- MISD provided opportunity for parent input on masks for remainder of year
- MISD provided opportunity for staff input on masks for remainder of year and vaccine update





# COVID Notifications & Contact Tracing - Required Practice

---

April 19, 2021

# COVID Notification and Contact Tracing - Current Practice

- In the event of a COVID test-confirmed case on a campus, the Campus Principal will **send a letter to the entire campus.**
- **Contact Tracing** is completed by nurses and administrators.
- **Parents are notified by phone** if it is determined their child was in close contact with the infected individual.
  - Students in close contact are **transitioned to remote learning** for the duration of the incubation period.
- **Letter 2** is sent out after close contact phone calls are made.
- **Letter 3** is distributed to teams/organizations where contact is likely.
- **Letter 4** is distributed when multiple cases are identified within an organization/sport and there is a need to suspend activity.



# MISD COVID Cases

# of NEW Cases Reported vs. Date

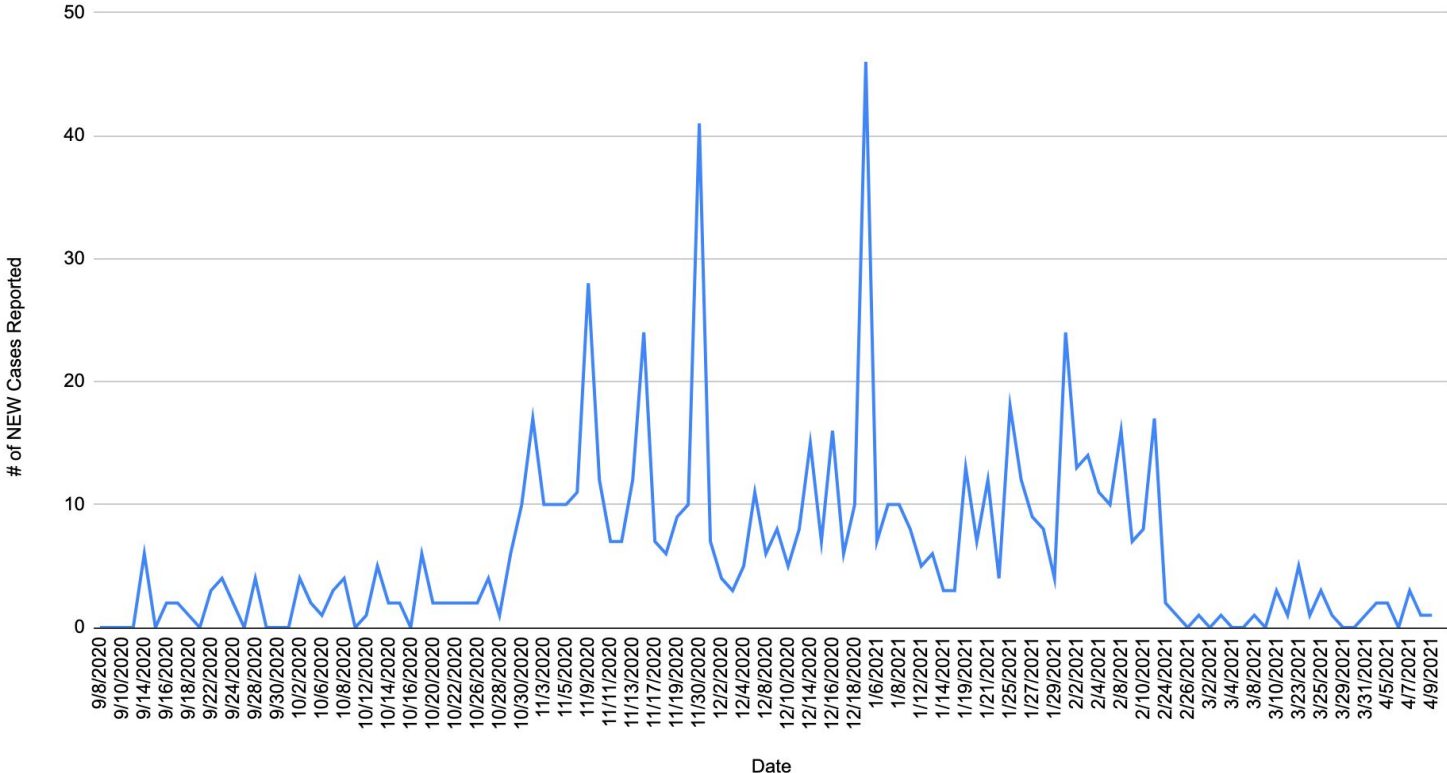



# COVID Vaccine and Mask Feedback Data

---

April 19, 2021

# Current Vaccine Information

(based on staff anonymous self-report as of **April 13, 2021**)

Total Staff in MISD: 1,253

Total Staff Responding: 878

Number of Staff <b>Fully Vaccinated</b>	49.9% of Respondents
Number of Staff w/ <b>1st Dose Only</b>	10.8% of Respondents
Number of Staff <b>Waiting</b> on an Appointment	4.1% of Respondents
Number of Staff <b>Opting Out</b> of Vaccine	16.5% of Respondents
Number of Staff <b>Undecided</b> on Vaccine	18.7% of Respondents



# Mask Survey Data (as of 4/13/21)

<b>Staff Mask Mandate Feedback</b> <i>(878 responses out of 1,253 staff)</i>		<b>Middle School Parent Mask Mandate Feedback</b> <i>(1,688 responses out of 2,470 MS Students)</i>	
Prefer current Mask Mandate ALL Staff & ALL Students K-12th	<b>53.7%</b>	Prefer current Mask Mandate ALL Staff & ALL Students K-12th	<b>35.3%</b>
Prefer Mask Mandate to be Modified ALL Staff & ALL Students 3rd-12th	<b>6.1%</b>	Prefer Mask Mandate to be Modified ALL Staff & ALL Students 3rd-12th	<b>6.3%</b>
Prefers Mask Mandate to be Modified <b>OPTIONAL</b> for ALL Staff & Students	<b>40.2%</b>	Prefers Mask Mandate to be Modified <b>OPTIONAL</b> for ALL Staff & Students	<b>58.4%</b>
<b>Elementary Parent Mask Mandate Feedback</b> <i>(4,162 responses out of 4,388 Elem Students)</i>		<b>High School Parent Mask Mandate Feedback</b> <i>(2,317 responses out of 3,084)</i>	
Prefer current Mask Mandate ALL Staff & ALL Students K-12th	<b>30%</b>	Prefer current Mask Mandate ALL Staff & ALL Students K-12th	<b>28%</b>
Prefer Mask Mandate to be Modified ALL Staff & ALL Students 3rd-12th	<b>2.9%</b>	Prefer Mask Mandate to be Modified ALL Staff & ALL Students 3rd-12th	<b>15.8%</b>
Prefers Mask Mandate to be Modified <b>OPTIONAL</b> for ALL Staff & Students	<b>67.2%</b>	Prefers Mask Mandate to be Modified <b>OPTIONAL</b> for ALL Staff & Students	<b>63.3%</b>

# Quarantine and Mask Guideline Updates - Consultation with Local Health Authority

- **Quarantine Time**
  - 10 day mandatory quarantine for exposed individuals (*as of March 2021*)
  - Continue to monitor systems for the following 4 days
- **Fully Vaccinated Staff Members**
  - Pfizer/Moderna (2 doses); Johnson & Johnson (1 dose)
    - No quarantine for 3 months
- **UIL Outdoor Activity and Weight Room Update**
  - Outdoor capacity 75%
  - Masks required for entering and exiting
  - Masks may be removed when seated 6 feet from non-family members
- **Masks Mandate**
  - Masks for All Staff & All Students K-12
  - Mask exceptions



# Next Steps

- **Tonight - Board Discussion on COVID Update**
  - Any changes to the current mask mandate requires Board Action
- **May 2021 Board Meeting**
  - Summer COVID-19 Mitigation Guidelines
    - Summer school, summer camps, athletic training, band, etc.
- **June/July 2021 Board Meeting**
  - Set 2021-2022 School Year Mitigation Efforts *(if needed)*
  - Final Decision on Virtual Learning Option *(pending legislative action)*





**Midlothian I.S.D. School Board Agenda Item Detail**  
**L.A. Mills Administrative Complex Boardroom**

<b>Board Meeting Date:</b>	<b>April 19, 2021</b>	
<b>Item:</b>	<b>Consider Board Resolution to State Officials Regarding Federal Elementary and Secondary School Emergency Relief Funds</b>	
<b>Supporting Document(s):</b>	Electronic: Yes <input checked="" type="checkbox"/> No <input type="checkbox"/>	Hard Copy: Yes <input type="checkbox"/> No <input checked="" type="checkbox"/>
<b>Background Information:</b>	<p>In an effort to communicate to our Texas state officials regarding our expectations of using the CARES Act elementary and secondary school emergency relief funds, the Midlothian ISD Board of Trustees encourages and expects that these funds are distributed in the manner in which the CARES Act was intended. These funds are allocated to support its public schools as these schools have had to allocate budgets to address pandemic challenges and financial burdens to ensure students receive the best education possible during this time.</p>	
<b>Fiscal Impact/Budget Function Code:</b>	N/A	
<b>Policy:</b>	N/A	
<b>District Goal:</b>	Build a strong foundation of the MISD culture through communication and engagement to empower all stakeholders.	
<b>Administration Recommended Option:</b>	Approve the Midlothian ISD Board of Trustees Resolution	
<b>Motion:</b>	Discussion & Action	
<b>Presenter:</b>	Matt Sanders, Board President Andrea Walton, Board Vice President Bobby Soto, Board Secretary	

---

**RESOLUTION OF  
THE MIDLOTHIAN INDEPENDENT SCHOOL DISTRICT BOARD OF TRUSTEES  
REGARDING FEDERAL ELEMENTARY AND SECONDARY SCHOOL  
EMERGENCY RELIEF FUNDS**

WHEREAS, the Federal Government has allocated CARES Act Elementary and Secondary School Emergency Relief (ESSER II and III) funds to Texas;

WHEREAS, the State of Texas has received these funding allocation amounts that are intended to supplement the needs of Texas school districts as they support the unfinished learning and social emotional needs of the students we serve;

WHEREAS, local education agencies in other states have already received their allocations and planning amounts and Texas has not allocated these funds to local education agencies to allow for planning and budgeting to address unfinished learning for the children of Texas;

WHEREAS, the needs of Texas' schools and its children are of paramount concern to both the people of Texas and the long-term economic and cultural aspects of both the future of our State and our Nation;

WHEREAS, the People of the United States of America have proven their exceptionalism time and time again to the world and the People of Texas have continually proven their exceptionalism both to the world and to all of the other States in the Union who continue to look to Texas for bravery, integrity and leadership;

WHEREAS, the Great State of Texas will only continue to maintain its greatness, exceptionalism, cultural uniqueness, and economic edge with a high-quality workforce and educated citizenry through a continued statewide commitment to quality public education for all;

WHEREAS, each State shall make allocations to local educational agencies in an expedited and timely manner and, to the extent practicable, not later than 60 days after the receipt of such funds;

WHEREAS, there has been a delay of the allocation of these funds and the initial discussions indicating the allocation will supplant funds already designated for districts rather than supplementing allotments local education agencies should already receive and are entitled to for the purpose of addressing unfinished learning;

WHEREAS, there is discussion about how the Texas Education Agency may add additional requirements above and beyond the Federal guidelines related to allowable partners and technical assistance providers with which local education agencies can utilize these funds;

WHEREAS, state government and regulators continue to erode the traditional local control of Texas public school districts to the detriment of Texas students, teachers, administrators, parents, taxpayers, Board Members, and local school districts statewide.

NOW, THEREFORE, BE IT RESOLVED, that the Board of Trustees of the Midlothian Independent School District respectfully asks, and recommends, that:

1. Governor Greg Abbott, the Texas Legislature, and the Texas Education Agency ensure all supplemental funds allocated from the Federal Government flow directly to local education agencies without additional restrictions beyond what the Federal Government has stipulated;
2. The Texas Education Agency utilizes these funds to supplement funding to school districts;
3. The Texas Education Agency does not supplant and provide these funds in place of funds already due to districts through the Foundation School Program and Available School Fund;
4. The Texas Education Agency does not attach additional restrictions and extend their control in place of local control on how these funds can best be utilized in districts across the state with such diversity.

Adopted on this the 19th day of April, 2021, by the Midlothian Independent School District Board of Trustees.

---

Matt Sanders, MISD Board of Trustees President

---

Andrea Walton, MISD Board of Trustees Vice President

---

Bobby Soto, MISD Board of Trustees Secretary

---

Heather Prather, MISD Board of Trustees

---

Gary Vineyard, MISD Board of Trustees

---

Tami Tobey, MISD Board of Trustees

**Midlothian I.S.D. School Board Agenda Item Detail**  
**L.A. Mills Administrative Complex Boardroom**

<b>Board Meeting Date:</b>	April 19, 2021																																																														
<b>Item:</b>	Review and Verification by Individual Trustees Regarding TASB's Continuing Education Report																																																														
<b>Supporting Document(s):</b>	Electronic: Yes <input type="checkbox"/> No <input checked="" type="checkbox"/>			Hard Copy: Yes <input type="checkbox"/> No <input checked="" type="checkbox"/>																																																											
<b>Background Information:</b>	<p>According to TEC §11.159(b); 19 Tex. Admin. Code § 61.1, at the last regular meeting of the board before an election of trustees, the presiding officer shall announce the name of each member who (as of the member's anniversary of election or appointment to the Board) has completed the required continuing education; has exceeded the required continuing education; and is deficient in meeting the required continuing education training.</p> <p>There are Four Tiers of board member continuing education:</p> <ul style="list-style-type: none"> <li>• Tier 1 – local district orientation, basic legal orientation and legal update training;</li> <li>• Tier 2 – team-building training with all board members and the superintendent;</li> <li>• Tier 3 – annual continuing education; and</li> <li>• Tier 4 – evaluating student academic performance</li> </ul> <p>Board meeting minutes must reflect the announcement and whether each trustee has met or is deficient in meeting the required training. If a trustee is deficient at the time of reporting, the district must post the information on the district's website until the trustee is no longer deficit in the training requirements.</p> <p>Based upon May 2020 – April 15, 2021 the following units are being reported.</p> <table border="1" style="width: 100%; border-collapse: collapse;"> <thead> <tr> <th style="width: 12.5%;">Board Member</th> <th style="width: 12.5%;">Local District, OMA, Intro to TEC</th> <th style="width: 12.5%;">Cyber-security</th> <th style="width: 12.5%;">Post Legislative Update</th> <th style="width: 12.5%;">Child Abuse Prevention (every 2 yrs)</th> <th style="width: 12.5%;">SB 1566 (every 2 yrs)</th> <th style="width: 12.5%;">Add'tl hours in 2021</th> <th style="width: 12.5%;">Team Bld</th> </tr> </thead> <tbody> <tr> <td>Heather Prather</td> <td>NA</td> <td>4/1/2021</td> <td>NA</td> <td>3/23/2021</td> <td>10/10/2020</td> <td>11.5</td> <td>6</td> </tr> <tr> <td>Matt Sanders</td> <td>NA</td> <td>5/1/2020</td> <td>NA</td> <td>11/5/2020</td> <td>June 2018</td> <td>5</td> <td>6</td> </tr> <tr> <td>Tami Tobey</td> <td>NA</td> <td>4/1/2021</td> <td>NA</td> <td>11/09/2020</td> <td>8/05/2020</td> <td>22.25</td> <td>6</td> </tr> <tr> <td>Gary Vineyard</td> <td>NA</td> <td>5/1/2020</td> <td>NA</td> <td>11/09/2020</td> <td>June 2018</td> <td>9.75</td> <td>6</td> </tr> <tr> <td>Andrea Walton</td> <td>NA</td> <td>4/1/2021</td> <td>NA</td> <td>3/27/2021</td> <td>3/31/2020</td> <td>57.25</td> <td>6</td> </tr> <tr> <td>Bobby Soto</td> <td>NA</td> <td>5/1/2020</td> <td>NA</td> <td>11/09/2020</td> <td>July 2019</td> <td>5.0</td> <td>6</td> </tr> </tbody> </table>							Board Member	Local District, OMA, Intro to TEC	Cyber-security	Post Legislative Update	Child Abuse Prevention (every 2 yrs)	SB 1566 (every 2 yrs)	Add'tl hours in 2021	Team Bld	Heather Prather	NA	4/1/2021	NA	3/23/2021	10/10/2020	11.5	6	Matt Sanders	NA	5/1/2020	NA	11/5/2020	June 2018	5	6	Tami Tobey	NA	4/1/2021	NA	11/09/2020	8/05/2020	22.25	6	Gary Vineyard	NA	5/1/2020	NA	11/09/2020	June 2018	9.75	6	Andrea Walton	NA	4/1/2021	NA	3/27/2021	3/31/2020	57.25	6	Bobby Soto	NA	5/1/2020	NA	11/09/2020	July 2019	5.0	6
Board Member	Local District, OMA, Intro to TEC	Cyber-security	Post Legislative Update	Child Abuse Prevention (every 2 yrs)	SB 1566 (every 2 yrs)	Add'tl hours in 2021	Team Bld																																																								
Heather Prather	NA	4/1/2021	NA	3/23/2021	10/10/2020	11.5	6																																																								
Matt Sanders	NA	5/1/2020	NA	11/5/2020	June 2018	5	6																																																								
Tami Tobey	NA	4/1/2021	NA	11/09/2020	8/05/2020	22.25	6																																																								
Gary Vineyard	NA	5/1/2020	NA	11/09/2020	June 2018	9.75	6																																																								
Andrea Walton	NA	4/1/2021	NA	3/27/2021	3/31/2020	57.25	6																																																								
Bobby Soto	NA	5/1/2020	NA	11/09/2020	July 2019	5.0	6																																																								
<b>Fiscal Impact/Budget Function Code:</b>	N/A																																																														

<b>Policy:</b>	<b>BBD(LEGAL)</b>
<b>District Goal:</b>	Build a strong foundation of the MISD culture through communication and engagement to empower all stakeholders.
<b>Administration Recommended Option:</b>	<b>The Board President will announce the continuing education reporting for the records.</b>
<b>Motion:</b>	<p><b>Presiding Officer will announce:</b>          “As the presiding officer, I am required to announce the name of each member who has completed the required continuing education; has exceeded the required continuing education; and who is deficient in meeting the required continuing education. There are four tiers/categories of board member continuing education:</p> <ul style="list-style-type: none"> <li>• Tier 1 local district orientation (for new members)</li> <li>• Tier 2 for team building training of all trustees and the superintendent</li> <li>• Tier 3 annual continuing education and</li> <li>• Tier 4 evaluating student academic performance</li> </ul> <p>Based upon the hours reported for April 2019 – April 15, 2021, all trustees have met or exceeded the requirement for Tier 1, Tier 2, and Tier 3 requirements; Tier 4 requirements have been completed by all trustees except Matt Sanders and Gary Vineyard who will complete the training in June 2021 when the training is available.”</p>
<b>Presenter:</b>	<b>Matt Sanders</b>

**Midlothian I.S.D. School Board Agenda Item Detail**  
**L.A. Mills Administrative Complex Boardroom**

<b>Board Meeting Date:</b>	April 19, 2021	
<b>Item:</b>	Business Reports	
<b>Supporting Document(s):</b>	Electronic: Yes <input checked="" type="checkbox"/> No <input type="checkbox"/>	Hard Copy: Yes <input type="checkbox"/> No <input checked="" type="checkbox"/>
<b>Background Information:</b>	Financial reports for the period ending March 31, 2021, are provided for Board review.	
<b>Fiscal Impact/Budget Function Code:</b>	N/A	
<b>Policy:</b>	N/A	
<b>District Goal:</b>	Facilitate budget process and building designs through allocated district resources that foster flexible and innovative learning spaces.	
<b>Administration Recommended Option:</b>	N/A	
<b>Motion:</b>	Report only – no motion required	
<b>Presenter:</b>	Jim Norris	

# MIDLOTHIAN INDEPENDENT SCHOOL DISTRICT

Midlothian, Texas

## BOARD REPORT

March 2021 Summary of Tax Deposits	1-2
March 2021 Budget Summaries	3-22
Fund Balance Report	23
Credit Card Billing	24-26
Construction Report	27

April 19, 2021

SUMMARY OF TAX DEPOSITS 2020 - 21

	5711 M & O Current	5712 M & O Prior	5719 Penalties & Interest	Total Maintenance & Operations	5711 I & S Current	5712 I & S Prior	5719 Penalties & Interest	Total Interest & Sinking
<b>YTD MONTHLY TAX RECEIPTS --</b>								
July-20	99,411.44	18,249.55	13,187.92	130,848.91	51,243.07	8,773.82	6,679.27	66,696.16
August-20	4,475.24	73,850.12	5,062.81	83,388.17	2,306.83	35,504.86	2,582.99	40,394.68
September-20	67,420.67	8,856.44	8,649.01	84,926.12	34,752.91	3,782.56	3,802.89	42,338.36
October-20	-	30,738.03	14,613.97	45,352.00	-	15,211.75	6,796.03	22,007.78
November-20	1,665,370.96	30,451.07	3,167.20	1,698,989.23	917,095.81	15,242.22	1,637.10	933,975.13
December-20	22,162,802.67	191,503.13	2,914.96	22,357,220.76	12,204,736.37	92,362.06	1,537.64	12,298,636.07
January-21	9,979,020.50	59,827.75	17,342.31	10,056,190.56	5,495,302.91	29,543.38	8,542.79	5,533,389.08
February-21	13,275,932.79	626.48	15,110.71	13,291,669.98	7,310,864.69	395.07	8,586.76	7,319,846.52
March-21	2,773,222.77	(19,298.08)	44,013.15	2,797,937.84	1,527,173.40	(9,717.34)	24,116.83	1,541,572.89
April-21				-				-
May-21				-				-
June-21				-				-
<b>YTD</b>	<b>\$50,027,657.04</b>	<b>\$394,804.49</b>	<b>\$124,062.04</b>	<b>\$50,546,523.57</b>	<b>\$27,543,475.99</b>	<b>\$191,098.38</b>	<b>\$64,282.30</b>	<b>\$27,798,856.67</b>
<b>Less TIRZ</b>	<b>(6,663,757.00)</b>			<b>(6,663,757.00)</b>				
<b>Non-TIRZ YTD</b>	<b>\$43,363,900.04</b>	<b>\$394,804.49</b>	<b>\$124,062.04</b>	<b>\$43,882,766.57</b>	<b>\$27,543,475.99</b>	<b>\$191,098.38</b>	<b>\$64,282.30</b>	<b>\$27,798,856.67</b>
<b>Budget 20-21, non-TIRZ</b>	<b>\$44,108,550.00</b>	<b>\$355,000.00</b>	<b>\$128,000.00</b>	<b>\$44,591,550.00</b>	<b>\$ 27,934,986.00</b>	<b>\$175,000.00</b>	<b>\$60,000.00</b>	<b>\$28,169,986.00</b>
<b>Percent Collected</b>	<b>98.31%</b>	<b>111.21%</b>	<b>96.92%</b>	<b>98.41%</b>	<b>98.60%</b>	<b>109.20%</b>	<b>107.14%</b>	<b>98.68%</b>
<b>Revenue Collected</b>								
<b>(over)/under budget</b>	<b>\$744,649.96</b>	<b>(\$39,804.49)</b>	<b>\$3,937.96</b>	<b>\$708,783.43</b>	<b>\$391,510.01</b>	<b>(\$16,098.38)</b>	<b>(\$4,282.30)</b>	<b>\$371,129.33</b>

SUMMARY OF TAX DEPOSITS 2020 - 21

Ellis County Tax Office												
Collection date	Deposit date	5711 M & O Current	5712 M & O Prior	5719 Penalties & Interest	5712.01 M & O CED	5719.01 P&I CED	5719.02 Rendition Penalty	Total Maintenance & Operations	5711 I & S Current	5712 I & S Prior	5719 Penalties & Interest	Total Interest & Sinking
March												
03/01/21	03/05/21	1,683,783.96	(3,611.69)	666.47			(4.75)	1,680,833.99 *	927,235.61	(1767.20)	364.63	925,833.04
03/03/21	03/08/21	84,787.84	(2,407.75)	2080.65			(0.73)	84,460.01 *	46,691.44	(1,211.54)	1,130.32	46,610.22
03/04/21	03/09/21	482,764.44	150.35	1,137.57			(6.43)	484,045.93 *	265,851.37	77.50	625.07	266,553.94
03/05/21	03/10/21	115,261.10	41.73	4,393.38			(37.28)	119,658.93 *	63,472.63	20.06	2,418.26	65,910.95
03/08/21	03/11/21	23,314.47	(110.47)	1,201.96				24,405.96 *	12,838.83	(59.51)	643.82	13,423.14
03/09/21	03/12/21	5,156.22	613.30	708.49			(5.27)	6,472.74 *	2,839.46	311.98	382.89	3,534.33
03/10/21	03/15/21	13,270.31	1,115.03	1,095.96			(7.36)	15,473.94 *	7,307.74	551.58	581.67	8,440.99
03/11/21	03/19/21	(8,248.91)	(19,809.43)	963.01				(27,095.33) *	(4,542.50)	(10,035.84)	532.51	(14,045.83)
03/12/21	03/19/21	4,564.83	930.31	1,308.77			(0.17)	6,803.74 *	2,513.76	479.55	712.49	3,705.80
03/15/21	03/19/21	6,131.51	5.16	538.99			(5.87)	6,669.79 *	3,376.48	2.64	296.73	3,675.85
03/16/21	03/19/21	15,992.87	(486.75)	556.02			(9.53)	16,052.61 *	8,807.05	(251.86)	306.22	8,861.41
03/17/21	03/23/21	(2,292.06)	0.00	473.44				(1,818.62) *	(1,262.23)	0.00	260.74	(1,001.49)
03/18/21	03/23/21	8,309.25	(3,896.09)	1,374.43				5,787.59 *	4,575.81	(2,008.32)	753.78	3,321.27
03/19/21	03/24/21	7,336.17	0.00	812.12				8,148.29 *	4,039.98	0.00	447.20	4,487.18
03/22/21	03/25/21	43,675.33	951.21	3,700.79				48,327.33 *	24,051.37	479.51	2,023.04	26,553.92
03/23/21	03/26/21	46,192.04	3,588.70	3,991.67			(23.65)	53,748.76 *	25,437.31	1,825.34	2,156.78	29,419.43
03/24/21	03/29/21	14,212.05	(2,332.64)	1,076.81			(90.12)	12,866.10 *	7,826.41	(1,198.96)	592.13	7,219.58
03/25/21	03/30/21	9,190.98	180.50	744.83			(2.04)	10,114.27 *	5,061.31	89.83	406.13	5,557.27
03/26/21	03/31/21	27,101.69	6,223.58	3,671.74			(0.47)	36,996.54 *	14,924.55	3,204.05	1,963.83	20,092.43
03/29/21	04/01/21	39,556.68	1,108.59	3,245.15			(15.98)	43,894.44 *	21,783.28	551.50	1,762.52	24,097.30
03/30/21	04/05/21	114,175.75	3,326.48	8,064.64				125,566.87 *	62,874.59	1,714.68	4,425.73	69,015.00
03/31/21	04/06/21	29,140.70	(4,878.20)	2,415.91				26,678.41 *	16,047.36	(2,492.33)	1,330.34	14,885.37
Spec Inv		9,845.55						0.00				0.00
								9,845.55	5,421.79			5,421.79
								0.00				0.00
								0.00				0.00
Month's totals		2,773,222.77	(19,298.08)	44,222.80	-	-	(209.65)	2,797,937.84	1,527,173.40	(9,717.34)	24,116.83	1,541,572.89

FND OBJ	2020-21	2020-21	March 2020-21	2020-21	2020-21	Encumbered	Unencumbered
	Original Budget	Revised Budget	Monthly Activity	FYTD Activity	FYTD %	Amount	Balance
170 Revenue	90,302.00	90,302.00	1,275.93	66,677.64	73.84	0.00	23,624.36
170 Expense	280,457.00	280,457.00	23,636.32	175,289.66	67.40	13,739.84	91,427.50
170 A. H. MEADOWS LIBRARY FUND	-190,155.00	-190,155.00	-22,360.39	-108,612.02	64.34	-13,739.84	-67,803.14
180 Revenue	365,003.00	365,003.00	29,444.75	273,888.16	75.04	0.00	91,114.84
180 Expense	1,094,224.00	1,094,224.00	99,416.33	738,790.79	84.52	186,046.41	169,386.80
180 ATHLETIC DEPARTMENT FUND	-729,221.00	-729,221.00	-69,971.58	-464,902.63	89.27	-186,046.41	-78,271.96
197 Revenue	0.00	0.00	242,378.11	242,378.11	0.00	0.00	-242,378.11
197 Expense	0.00	0.00	489,426.96	489,426.96	0.00	1,240,296.72	-1,729,723.68
197 Insurance Claims Snow 2021	0.00	0.00	-247,048.85	-247,048.85	0.00	-1,240,296.72	1,487,345.57
198 Revenue	0.00	5,000.00	1,190.47	4,601.38	92.03	0.00	398.62
198 Expense	0.00	607,862.00	45,231.30	290,242.87	49.76	12,201.74	305,417.39
198 COVID 19	0.00	-602,862.00	-44,040.83	-285,641.49	49.40	-12,201.74	-305,018.77
199 Revenue	95,842,614.00	99,688,542.00	3,848,084.83	75,192,843.95	75.33	-93,080.18	24,588,778.23
199 Expense	94,923,238.00	100,246,510.00	7,941,346.55	65,314,549.50	67.85	2,702,993.88	32,228,966.62
199 GENERAL FUND	919,376.00	-557,968.00	-4,093,261.72	9,878,294.45	-1,269.29	-2,796,074.06	-7,640,188.39
240 Revenue	3,878,416.00	3,893,416.00	329,635.37	2,311,216.72	59.36	0.00	1,582,199.28
240 Expense	3,690,183.00	3,831,183.00	293,328.36	2,005,850.14	54.14	68,462.77	1,756,870.09
240 FOOD SERVICE	188,233.00	62,233.00	36,307.01	305,366.58	380.67	-68,462.77	-174,670.81
599 Revenue	28,637,450.00	181,519,722.00	1,544,923.97	180,867,593.33	99.64	0.00	652,128.67
599 Expense	28,637,450.00	182,536,302.00	750.00	182,532,294.56	100.00	4,000.00	7.44
599 DEBT SERVICE	0.00	-1,016,580.00	1,544,173.97	-1,664,701.23	164.15	-4,000.00	652,121.23
Grand Revenue Totals	128,813,785.00	285,561,985.00	5,996,933.43	258,959,199.29	90.65	-93,080.18	26,695,865.89
Grand Expense Totals	128,625,552.00	288,596,538.00	8,893,135.82	251,546,444.48	88.63	4,227,741.36	32,822,352.16
Grand Totals	188,233.00	3,034,553.00	2,896,202.39	7,412,754.81	-244.28	4,320,821.54	6,126,486.27
	Profit	Loss	Loss	Profit		Loss	Loss

Number of Accounts: 5701

\*\*\*\*\* End of report \*\*\*\*\*

<u>FUND</u>	<u>FUNC</u>	<u>OB</u>	<u>OBJ</u>	<u>2020-21</u> <u>Original Budget</u>	<u>2020-21</u> <u>Revised Budget</u>	<u>March 2020-21</u> <u>Monthly Activity</u>	<u>2020-21</u> <u>FYTD Activity</u>	<u>2020-21</u> <u>FYTD %</u>	<u>Encumbered</u> <u>Amount</u>	<u>Unencumbered</u> <u>Balance</u>
170			A. H. MEADOWS LIBRARY FUND							
R			Revenue							
00										
170	00	57	REVENUE-LOCAL & INTERMED	75,000.00	75,000.00	0.00	55,839.75	74.45	0.00	19,160.25
170	00	58	STATE PROGRAM REVENUES	15,302.00	15,302.00	1,275.93	10,837.89	70.83	0.00	4,464.11
170	00	--		90,302.00	90,302.00	1,275.93	66,677.64	73.84	0.00	23,624.36
170	--	--	Revenue	90,302.00	90,302.00	1,275.93	66,677.64	73.84	0.00	23,624.36

Comparison of Revenues and Expenditures to Budget (Date: 3/2021)

				2020-21	2020-21	March 2020-21	2020-21	2020-21	Encumbered	Unencumbered
				Original Budget	Revised Budget	Monthly Activity	FYTD Activity	FYTD %	Amount	Balance
FUND	FUNC	OB	OBJ							
170			A. H. MEADOWS LIBRARY FUND							
E			Expense							
12			INST. RESOURCES & MEDIA SVCS							
170	12	61	PAYROLL COSTS	165,498.00	166,208.00	14,332.61	111,074.30	66.83	0.00	55,133.70
170	12	62	PURCHASE & CONTRACTED SVS	3,192.00	3,192.00	132.63	1,061.04	49.86	530.52	1,600.44
170	12	63	SUPPLIES AND MATERIALS	38,308.00	39,579.00	2,714.11	25,815.97	98.60	13,209.32	553.71
170	12	64	OTHER OPERATING EXPENSES	250.00	116.00	0.00	112.50	96.98	0.00	3.50
170	12	--	INST. RESOURCES & MEDIA SVCS	207,248.00	209,095.00	17,179.35	138,063.81	72.60	13,739.84	57,291.35
13			CURRICULUM DEV. & INST.STF DEV							
170	13	64	OTHER OPERATING EXPENSES	1,250.00	113.00	0.00	112.50	99.56	0.00	0.50
170	13	--	CURRICULUM DEV. & INST.STF DEV	1,250.00	113.00	0.00	112.50	99.56	0.00	0.50
52			SECURITY & MONITORING SERVICES							
170	52	61	PAYROLL COSTS	71,959.00	71,249.00	6,456.97	37,113.35	52.09	0.00	34,135.65
170	52	--	SECURITY & MONITORING SERVICES	71,959.00	71,249.00	6,456.97	37,113.35	52.09	0.00	34,135.65
170	--	--	Expense	280,457.00	280,457.00	23,636.32	175,289.66	67.40	13,739.84	91,427.50
170	--	--	A. H. MEADOWS LIBRARY FUND	-190,155.00	-190,155.00	-22,360.39	-108,612.02	64.34	-13,739.84	-67,803.14

Comparison of Revenues and Expenditures to Budget (Date: 3/2021)

<u>FUND</u>	<u>FUNC</u>	<u>OB</u>	<u>OBJ</u>	<u>2020-21</u> <u>Original Budget</u>	<u>2020-21</u> <u>Revised Budget</u>	<u>March 2020-21</u> <u>Monthly Activity</u>	<u>2020-21</u> <u>FYTD Activity</u>	<u>2020-21</u> <u>FYTD %</u>	<u>Encumbered</u> <u>Amount</u>	<u>Unencumbered</u> <u>Balance</u>
180			ATHLETIC DEPARTMENT FUND							
R			Revenue							
00										
180	00	57	REVENUE-LOCAL & INTERMED	364,961.00	364,961.00	29,022.85	268,775.19	73.64	0.00	96,185.81
180	00	58	STATE PROGRAM REVENUES	42.00	42.00	421.90	5,112.97	12,173.74	0.00	-5,070.97
180	00	--		365,003.00	365,003.00	29,444.75	273,888.16	75.04	0.00	91,114.84
180	--	--	Revenue	365,003.00	365,003.00	29,444.75	273,888.16	75.04	0.00	91,114.84

Comparison of Revenues and Expenditures to Budget (Date: 3/2021)

				2020-21	2020-21	March 2020-21	2020-21	2020-21	Encumbered	Unencumbered
				Original Budget	Revised Budget	Monthly Activity	FYTD Activity	FYTD %	Amount	Balance
FUND	FUNC	OB	OBJ							
180			ATHLETIC DEPARTMENT FUND							
E			Expense							
36			COCURR./EXTRACURR.ACTIVITIES							
180	36	61	PAYROLL COSTS	89,700.00	89,659.00	6,867.60	82,449.65	91.96	0.00	7,209.35
180	36	62	PURCHASE & CONTRACTED SVS	198,160.00	219,335.08	5,334.75	153,588.61	89.27	42,207.37	23,539.10
180	36	63	SUPPLIES AND MATERIALS	357,514.00	404,642.37	39,358.49	249,491.21	93.02	126,922.18	28,228.98
180	36	64	OTHER OPERATING EXPENSES	447,350.00	376,682.55	47,454.04	250,850.28	71.09	16,916.86	108,915.41
180	36	--	COCURR./EXTRACURR.ACTIVITIES	1,092,724.00	1,090,319.00	99,014.88	736,379.75	84.60	186,046.41	167,892.84
51			PLANT MAINTENANCE & OPERATIONS							
180	51	62	PURCHASE & CONTRACTED SVS	1,500.00	3,905.00	401.45	2,411.04	61.74	0.00	1,493.96
180	51	--	PLANT MAINTENANCE & OPERATIONS	1,500.00	3,905.00	401.45	2,411.04	61.74	0.00	1,493.96
180	--	--	Expense	1,094,224.00	1,094,224.00	99,416.33	738,790.79	84.52	186,046.41	169,386.80
180	--	--	ATHLETIC DEPARTMENT FUND	-729,221.00	-729,221.00	-69,971.58	-464,902.63	89.27	-186,046.41	-78,271.96



MIDLOTHIAN I.S.D.  
Comparison of Revenues and Expenditures to Budget (Date: 3/2021)

				2020-21	2020-21	March 2020-21	2020-21	2020-21	Encumbered	Unencumbered
				Original Budget	Revised Budget	Monthly Activity	FYTD Activity	FYTD %	Amount	Balance
FUND	FUNC	OB	OBJ							
197			Insurance Claims Snow 2021							
E			Expense							
11			INSTRUCTION							
197	11	63	SUPPLIES AND MATERIALS	0.00	0.00	53.00	53.00	0.00	0.00	-53.00
197	11	--	INSTRUCTION	0.00	0.00	53.00	53.00	0.00	0.00	-53.00
34			PUPIL TRANSPORTATION							
197	34	64	OTHER OPERATING EXPENSES	0.00	0.00	1,499.68	1,499.68	0.00	0.00	-1,499.68
197	34	--	PUPIL TRANSPORTATION	0.00	0.00	1,499.68	1,499.68	0.00	0.00	-1,499.68
51			PLANT MAINTENANCE & OPERATIONS							
197	51	61	PAYROLL COSTS	0.00	0.00	32,499.16	32,499.16	0.00	0.00	-32,499.16
197	51	62	PURCHASE & CONTRACTED SVS	0.00	0.00	453,190.00	453,190.00	0.00	1,236,762.64	-1,689,952.64
197	51	63	SUPPLIES AND MATERIALS	0.00	0.00	2,091.00	2,091.00	0.00	1,622.48	-3,713.48
197	51	64	OTHER OPERATING EXPENSES	0.00	0.00	94.12	94.12	0.00	0.00	-94.12
197	51	--	PLANT MAINTENANCE & OPERATIONS	0.00	0.00	487,874.28	487,874.28	0.00	1,238,385.12	-1,726,259.40
53			DATA PROCESSING SERVICES							
197	53	63	SUPPLIES AND MATERIALS	0.00	0.00	0.00	0.00	0.00	1,911.60	-1,911.60
197	53	--	DATA PROCESSING SERVICES	0.00	0.00	0.00	0.00	0.00	1,911.60	-1,911.60
197	--	--	Expense	0.00	0.00	489,426.96	489,426.96	0.00	1,240,296.72	-1,729,723.68
197	--	--	Insurance Claims Snow 2021	0.00	0.00	-247,048.85	-247,048.85	0.00	-1,240,296.72	1,487,345.57

Comparison of Revenues and Expenditures to Budget (Date: 3/2021)

<u>FUND</u>	<u>FUNC</u>	<u>OB</u>	<u>OBJ</u>	2020-21 <u>Original Budget</u>	2020-21 <u>Revised Budget</u>	March 2020-21 <u>Monthly Activity</u>	2020-21 <u>FYTD Activity</u>	2020-21 <u>FYTD %</u>	<u>Encumbered</u> <u>Amount</u>	<u>Unencumbered</u> <u>Balance</u>
198			COVID 19							
R			Revenue							
00										
198	00	58	STATE PROGRAM REVENUES	0.00	5,000.00	1,190.47	4,601.38	92.03	0.00	398.62
198	00	--		0.00	5,000.00	1,190.47	4,601.38	92.03	0.00	398.62
198	--	--	Revenue	0.00	5,000.00	1,190.47	4,601.38	92.03	0.00	398.62

MIDLOTHIAN I.S.D.  
Comparison of Revenues and Expenditures to Budget (Date: 3/2021)

				2020-21	2020-21	March 2020-21	2020-21	2020-21	Encumbered	Unencumbered
				Original Budget	Revised Budget	Monthly Activity	FYTD Activity	FYTD %	Amount	Balance
FUND	FUNC	OB	OBJ							
198			COVID 19							
E			Expense							
11			INSTRUCTION							
198	11	61	PAYROLL COSTS	0.00	347,462.00	25,291.34	145,311.97	41.82	0.00	202,150.03
198	11	63	SUPPLIES AND MATERIALS	0.00	145,000.00	14,541.67	96,429.11	73.39	9,990.00	38,580.89
198	11	--	INSTRUCTION	0.00	492,462.00	39,833.01	241,741.08	51.12	9,990.00	240,730.92
33			HEALTH SERVICES							
198	33	63	SUPPLIES AND MATERIALS	0.00	10,000.00	0.00	-42.24	1.14	155.74	9,886.50
198	33	--	HEALTH SERVICES	0.00	10,000.00	0.00	-42.24	1.14	155.74	9,886.50
34			PUPIL TRANSPORTATION							
198	34	61	PAYROLL COSTS	0.00	18,770.00	1,516.26	11,467.86	61.10	0.00	7,302.14
198	34	63	SUPPLIES AND MATERIALS	0.00	400.00	0.00	394.74	98.69	0.00	5.26
198	34	64	OTHER OPERATING EXPENSES	0.00	25,000.00	2,050.20	16,972.80	67.89	0.00	8,027.20
198	34	--	PUPIL TRANSPORTATION	0.00	44,170.00	3,566.46	28,835.40	65.28	0.00	15,334.60
51			PLANT MAINTENANCE & OPERATIONS							
198	51	62	PURCHASE & CONTRACTED SVS	0.00	38,000.00	1,831.83	19,708.63	57.28	2,056.00	16,235.37
198	51	63	SUPPLIES AND MATERIALS	0.00	23,230.00	0.00	0.00	0.00	0.00	23,230.00
198	51	--	PLANT MAINTENANCE & OPERATIONS	0.00	61,230.00	1,831.83	19,708.63	35.55	2,056.00	39,465.37
198	--	--	Expense	0.00	607,862.00	45,231.30	290,242.87	49.76	12,201.74	305,417.39
198	--	--	COVID 19	0.00	-602,862.00	-44,040.83	-285,641.49	49.40	-12,201.74	-305,018.77

Comparison of Revenues and Expenditures to Budget (Date: 3/2021)

FUND	FUNC	OB	OBJ	2020-21	2020-21	March 2020-21	2020-21	2020-21	Encumbered	Unencumbered
				Original Budget	Revised Budget	Monthly Activity	FYTD Activity	FYTD %	Amount	Balance
199				GENERAL FUND						
R				Revenue						
00										
199	00	57	REVENUE-LOCAL & INTERMED	53,431,917.00	54,337,348.00	2,818,756.00	50,952,841.38	93.77	0.00	3,384,506.62
199	00	58	STATE PROGRAM REVENUES	41,331,197.00	44,032,042.00	1,015,369.50	23,861,892.59	54.19	0.00	20,170,149.41
199	00	59	FEDERAL PROGRAM REVENUES	1,079,500.00	1,319,152.00	13,959.33	378,109.98	21.61	-93,080.18	1,034,122.20
199	00	--		95,842,614.00	99,688,542.00	3,848,084.83	75,192,843.95	75.33	-93,080.18	24,588,778.23
199	--	--	Revenue	95,842,614.00	99,688,542.00	3,848,084.83	75,192,843.95	75.33	-93,080.18	24,588,778.23

				2020-21	2020-21	March 2020-21	2020-21	2020-21	Encumbered	Unencumbered
				Original Budget	Revised Budget	Monthly Activity	FYTD Activity	FYTD %	Amount	Balance
FUND	FUNC	OB	OBJ							
199			GENERAL FUND							
E			Expense							
11			INSTRUCTION							
199	11	61	PAYROLL COSTS	48,009,003.00	48,743,392.02	4,580,960.99	37,182,631.93	76.28	0.00	11,560,760.09
199	11	62	PURCHASE & CONTRACTED SVS	760,272.00	1,046,000.89	70,921.32	574,801.77	86.48	329,771.90	141,427.22
199	11	63	SUPPLIES AND MATERIALS	2,352,296.00	2,354,244.20	449,723.68	1,716,384.48	94.71	513,410.58	124,449.14
199	11	64	OTHER OPERATING EXPENSES	122,119.00	81,846.89	10,194.36	34,197.75	53.67	9,729.59	37,919.55
199	11	66	CPTL OUTLY LAND BLDG & EQUIP	0.00	22,823.00	0.00	5,885.00	100.00	16,937.97	0.03
199	11	--	INSTRUCTION	51,243,690.00	52,248,307.00	5,111,800.35	39,513,900.93	77.29	869,850.04	11,864,556.03
12			INST. RESOURCES & MEDIA SVCS							
199	12	61	PAYROLL COSTS	777,937.00	857,889.00	71,263.93	603,164.43	70.31	0.00	254,724.57
199	12	62	PURCHASE & CONTRACTED SVS	1,075.00	430.01	0.00	0.00	0.00	0.00	430.01
199	12	63	SUPPLIES AND MATERIALS	105,278.00	118,507.99	5,418.63	58,398.87	82.77	39,692.66	20,416.46
199	12	64	OTHER OPERATING EXPENSES	2,030.00	1,124.00	245.00	695.00	81.12	216.80	212.20
199	12	--	INST. RESOURCES & MEDIA SVCS	886,320.00	977,951.00	76,927.56	662,258.30	71.80	39,909.46	275,783.24
13			CURRICULUM DEV. & INST.STF DEV							
199	13	61	PAYROLL COSTS	905,048.00	1,145,170.00	97,075.10	889,713.02	77.69	0.00	255,456.98
199	13	62	PURCHASE & CONTRACTED SVS	95,350.00	97,446.00	2,355.52	78,878.61	92.86	11,607.15	6,960.24
199	13	63	SUPPLIES AND MATERIALS	37,466.00	46,409.00	7,645.89	29,119.43	74.58	5,493.32	11,796.25
199	13	64	OTHER OPERATING EXPENSES	314,509.00	189,702.00	1,036.72	129,907.62	77.89	17,859.27	41,935.11
199	13	--	CURRICULUM DEV. & INST.STF DEV	1,352,373.00	1,478,727.00	108,113.23	1,127,618.68	78.62	34,959.74	316,148.58
21			INSTRUCTIONAL LEADERSHIP							
199	21	61	PAYROLL COSTS	1,089,849.00	1,012,309.36	75,581.63	742,609.82	73.36	0.00	269,699.54
199	21	62	PURCHASE & CONTRACTED SVS	11,931.00	6,242.00	353.61	4,510.17	94.31	1,376.40	355.43
199	21	63	SUPPLIES AND MATERIALS	29,766.00	34,940.00	390.91	13,057.05	52.19	5,177.59	16,705.36
199	21	64	OTHER OPERATING EXPENSES	30,380.00	15,299.64	350.28	3,499.56	29.41	1,000.00	10,800.08
199	21	--	INSTRUCTIONAL LEADERSHIP	1,161,926.00	1,068,791.00	76,676.43	763,676.60	72.16	7,553.99	297,560.41

Comparison of Revenues and Expenditures to Budget (Date: 3/2021)

FUND	FUNC	OB	OBJ	2020-21	2020-21	March 2020-21	2020-21	2020-21	Encumbered	Unencumbered
				Original Budget	Revised Budget	Monthly Activity	FYTD Activity	FYTD %		
199			GENERAL FUND							
E			Expense							
23			SCHOOL LEADERSHIP							
199	23	61	PAYROLL COSTS	4,643,329.00	5,005,829.00	427,804.75	3,698,542.47	73.88	0.00	1,307,286.53
199	23	62	PURCHASE & CONTRACTED SVS	22,900.00	3,675.00	90.39	1,126.01	61.08	1,118.63	1,430.36
199	23	63	SUPPLIES AND MATERIALS	49,560.00	70,515.00	9,498.18	42,830.48	75.46	10,380.75	17,303.77
199	23	64	OTHER OPERATING EXPENSES	60,180.00	23,961.00	1,551.90	13,302.03	66.76	2,694.24	7,964.73
199	23	--	SCHOOL LEADERSHIP	4,775,969.00	5,103,980.00	438,945.22	3,755,800.99	73.86	14,193.62	1,333,985.39
31			GUIDANCE & COUNSELING							
199	31	61	PAYROLL COSTS	3,152,456.00	3,299,832.00	291,555.30	2,471,216.27	74.89	0.00	828,615.73
199	31	62	PURCHASE & CONTRACTED SVS	1,500.00	1,750.00	0.00	729.00	41.66	0.00	1,021.00
199	31	63	SUPPLIES AND MATERIALS	53,005.00	53,374.00	2,886.72	38,324.04	81.78	5,323.66	9,726.30
199	31	64	OTHER OPERATING EXPENSES	22,160.00	15,981.00	398.53	8,276.84	64.84	2,084.86	5,619.30
199	31	--	GUIDANCE & COUNSELING	3,229,121.00	3,370,937.00	294,840.55	2,518,546.15	74.93	7,408.52	844,982.33
33			HEALTH SERVICES							
199	33	61	PAYROLL COSTS	1,032,911.00	1,043,475.00	97,597.61	791,332.81	75.84	0.00	252,142.19
199	33	62	PURCHASE & CONTRACTED SVS	41,035.00	10,915.00	0.00	770.00	7.05	0.00	10,145.00
199	33	63	SUPPLIES AND MATERIALS	31,823.00	121,923.50	5,096.18	108,668.41	92.92	4,617.42	8,637.67
199	33	64	OTHER OPERATING EXPENSES	4,160.00	1,199.50	0.00	638.00	58.61	65.00	496.50
199	33	--	HEALTH SERVICES	1,109,929.00	1,177,513.00	102,693.79	901,409.22	76.95	4,682.42	271,421.36
34			PUPIL TRANSPORTATION							
199	34	61	PAYROLL COSTS	2,059,632.00	2,118,351.00	207,194.29	1,565,957.84	73.92	0.00	552,393.16
199	34	62	PURCHASE & CONTRACTED SVS	122,500.00	139,900.00	7,213.72	108,297.69	82.43	7,019.81	24,582.50
199	34	63	SUPPLIES AND MATERIALS	589,001.00	456,101.00	31,428.36	288,968.80	75.03	53,229.95	113,902.25
199	34	64	OTHER OPERATING EXPENSES	-291,425.00	-217,925.00	-60,397.83	-168,384.28	77.22	110.00	-49,650.72
199	34	66	CPTL OUTLY LAND BLDG & EQUIP	0.00	394,228.00	0.00	394,228.00	100.00	0.00	0.00
199	34	--	PUPIL TRANSPORTATION	2,479,708.00	2,890,655.00	185,438.54	2,189,068.05	77.82	60,359.76	641,227.19

				2020-21	2020-21	March 2020-21	2020-21	2020-21	Encumbered	Unencumbered
				Original Budget	Revised Budget	Monthly Activity	FYTD Activity	FYTD %	Amount	Balance
FUND	FUNC	OB	OBJ							
199			GENERAL FUND							
E			Expense							
35			FOOD SERVICES							
199	35	61	PAYROLL COSTS	0.00	3,044.00	760.85	2,282.60	74.99	0.00	761.40
199	35	--	FOOD SERVICES	0.00	3,044.00	760.85	2,282.60	74.99	0.00	761.40
36			COCURR./EXTRACURR.ACTIVITIES							
199	36	61	PAYROLL COSTS	2,427,783.00	2,445,661.00	202,322.77	1,872,310.78	76.56	0.00	573,350.22
199	36	62	PURCHASE & CONTRACTED SVS	96,227.00	115,590.76	10,029.77	74,703.63	99.14	39,891.48	995.65
199	36	63	SUPPLIES AND MATERIALS	146,579.00	113,716.47	19,348.79	56,003.21	93.99	50,876.39	6,836.87
199	36	64	OTHER OPERATING EXPENSES	577,759.00	340,917.77	39,879.90	173,207.82	54.20	11,581.22	156,128.73
199	36	66	CPTL OUTLY LAND BLDG & EQUIP	0.00	140,947.00	0.00	20,558.00	14.59	0.00	120,389.00
199	36	--	COCURR./EXTRACURR.ACTIVITIES	3,248,348.00	3,156,833.00	271,581.23	2,196,783.44	72.83	102,349.09	857,700.47
41			GENERAL ADMINISTRATION							
199	41	61	PAYROLL COSTS	2,508,518.00	2,665,703.00	214,241.02	1,956,348.42	73.39	0.00	709,354.58
199	41	62	PURCHASE & CONTRACTED SVS	845,746.00	822,026.18	34,958.98	410,045.91	79.05	239,742.16	172,238.11
199	41	63	SUPPLIES AND MATERIALS	116,899.00	145,096.21	6,778.67	71,622.65	55.62	9,074.90	64,398.66
199	41	64	OTHER OPERATING EXPENSES	218,968.00	214,999.61	13,357.50	126,738.53	63.49	9,762.28	78,498.80
199	41	--	GENERAL ADMINISTRATION	3,690,131.00	3,847,825.00	269,336.17	2,564,755.51	73.37	258,579.34	1,024,490.15
51			PLANT MAINTENANCE & OPERATIONS							
199	51	61	PAYROLL COSTS	4,216,223.00	4,268,375.76	388,975.20	3,098,761.22	72.60	0.00	1,169,614.54
199	51	62	PURCHASE & CONTRACTED SVS	3,375,670.00	3,466,471.72	252,586.87	2,191,965.13	69.50	217,301.33	1,057,205.26
199	51	63	SUPPLIES AND MATERIALS	858,255.00	690,258.09	26,478.04	395,435.93	68.58	77,957.52	216,864.64
199	51	64	OTHER OPERATING EXPENSES	882,100.00	947,618.43	371.55	884,219.68	99.43	57,951.74	5,447.01
199	51	66	CPTL OUTLY LAND BLDG & EQUIP	0.00	97,530.00	21,331.00	63,438.26	94.85	29,065.25	5,026.49
199	51	--	PLANT MAINTENANCE & OPERATIONS	9,332,248.00	9,470,254.00	689,742.66	6,633,820.22	74.09	382,275.84	2,454,157.94

Comparison of Revenues and Expenditures to Budget (Date: 3/2021)

FUND	FUNC	OB	OBJ	2020-21	2020-21	March 2020-21	2020-21	2020-21	Encumbered	Unencumbered
				Original Budget	Revised Budget	Monthly Activity	FYTD Activity	FYTD %	Amount	Balance
199				GENERAL FUND						
E				Expense						
52				SECURITY & MONITORING SERVICES						
199	52	61	PAYROLL COSTS	305,461.00	320,810.00	31,948.20	234,902.15	73.22	0.00	85,907.85
199	52	62	PURCHASE & CONTRACTED SVS	818,425.00	897,413.00	833.40	171,238.56	90.00	636,441.17	89,733.27
199	52	63	SUPPLIES AND MATERIALS	155,275.00	136,938.00	2,421.44	78,401.63	66.79	13,066.05	45,470.32
199	52	64	OTHER OPERATING EXPENSES	63,204.00	41,888.00	214.68	214.68	79.78	33,204.48	8,468.84
199	52	--	SECURITY & MONITORING SERVICES	1,342,365.00	1,397,049.00	35,417.72	484,757.02	83.57	682,711.70	229,580.28
53				DATA PROCESSING SERVICES						
199	53	61	PAYROLL COSTS	1,314,233.00	1,327,748.00	108,540.62	938,270.51	70.67	0.00	389,477.49
199	53	62	PURCHASE & CONTRACTED SVS	58,450.00	119,041.00	1,726.97	57,136.84	80.68	38,902.89	23,001.27
199	53	63	SUPPLIES AND MATERIALS	588,718.00	515,850.00	17,721.52	380,892.03	83.57	50,206.61	84,751.36
199	53	64	OTHER OPERATING EXPENSES	20,035.00	10,510.00	3.00	4,000.72	87.24	5,168.38	1,340.90
199	53	--	DATA PROCESSING SERVICES	1,981,436.00	1,973,149.00	127,992.11	1,380,300.10	74.73	94,277.88	498,571.02
61				COMMUNITY SERVICES						
199	61	61	PAYROLL COSTS	8,500.00	37,070.00	8,760.21	27,295.13	73.63	0.00	9,774.87
199	61	--	COMMUNITY SERVICES	8,500.00	37,070.00	8,760.21	27,295.13	73.63	0.00	9,774.87
71				DEBT SERVICES						
199	71	65	DEBT SERVICE	228,602.00	172,720.00	0.00	172,719.02	100.00	0.00	0.98
199	71	--	DEBT SERVICES	228,602.00	172,720.00	0.00	172,719.02	100.00	0.00	0.98
95				PYMTS.TO JJAEP PROGRAMS						
199	95	62	PURCHASE & CONTRACTED SVS	60,000.00	0.00	0.00	0.00	0.00	0.00	0.00
199	95	--	PYMTS.TO JJAEP PROGRAMS	60,000.00	0.00	0.00	0.00	0.00	0.00	0.00

Comparison of Revenues and Expenditures to Budget (Date: 3/2021)

FUND	FUNC	OB	OBJ	2020-21	2020-21	March 2020-21	2020-21	2020-21	Encumbered	Unencumbered
				Original Budget	Revised Budget	Monthly Activity	FYTD Activity	FYTD %	Amount	Balance
199			GENERAL FUND							
E			Expense							
97			PAYMENTS TO TAX INCREMENT FUND							
199	97	64	OTHER OPERATING EXPENSES	8,200,572.00	11,279,705.00	0.00	0.00	0.00	0.00	11,279,705.00
199	97	--	PAYMENTS TO TAX INCREMENT FUND	8,200,572.00	11,279,705.00	0.00	0.00	0.00	0.00	11,279,705.00
99			Tax Costs							
199	99	62	PURCHASE & CONTRACTED SVS	592,000.00	592,000.00	142,319.93	419,557.54	95.18	143,882.48	28,559.98
199	99	--	Tax Costs	592,000.00	592,000.00	142,319.93	419,557.54	95.18	143,882.48	28,559.98
199	--	--	Expense	94,923,238.00	100,246,510.00	7,941,346.55	65,314,549.50	67.85	2,702,993.88	32,228,966.62
199	--	--	GENERAL FUND	919,376.00	-557,968.00	-4,093,261.72	9,878,294.45	-1,269.29	-2,796,074.06	-7,640,188.39

Comparison of Revenues and Expenditures to Budget (Date: 3/2021)

FUND	FUNC	OB	OBJ	2020-21	2020-21	March 2020-21	2020-21	2020-21	Encumbered	Unencumbered
				Original Budget	Revised Budget	Monthly Activity	FYTD Activity	FYTD %	Amount	Balance
240			FOOD SERVICE							
R			Revenue							
00										
240	00	57	REVENUE-LOCAL & INTERMED	2,438,261.00	2,453,261.00	43,142.89	381,383.73	15.55	0.00	2,071,877.27
240	00	58	STATE PROGRAM REVENUES	11,668.00	11,668.00	0.00	5,331.29	45.69	0.00	6,336.71
240	00	59	FEDERAL PROGRAM REVENUES	1,428,487.00	1,428,487.00	286,492.48	1,924,501.70	134.72	0.00	-496,014.70
240	00	--		3,878,416.00	3,893,416.00	329,635.37	2,311,216.72	59.36	0.00	1,582,199.28
240	--	--	Revenue	3,878,416.00	3,893,416.00	329,635.37	2,311,216.72	59.36	0.00	1,582,199.28

Comparison of Revenues and Expenditures to Budget (Date: 3/2021)

			2020-21	2020-21	March 2020-21	2020-21	2020-21	Encumbered	Unencumbered
FUND	FUNC	OB OBJ	Original Budget	Revised Budget	Monthly Activity	FYTD Activity	FYTD %	Amount	Balance
240		FOOD SERVICE							
E		Expense							
35		FOOD SERVICES							
240	35	61 PAYROLL COSTS	24,000.00	81,500.00	5,980.48	51,501.00	63.19	0.00	29,999.00
240	35	62 PURCHASE & CONTRACTED SVS	3,385,583.00	3,382,083.00	265,081.12	1,733,481.36	51.40	4,890.74	1,643,710.90
240	35	63 SUPPLIES AND MATERIALS	220,000.00	267,605.00	22,186.76	217,029.11	90.72	25,733.67	24,842.22
240	35	64 OTHER OPERATING EXPENSES	3,500.00	3,500.00	0.00	3,448.00	98.75	8.25	43.75
240	35	66 CPTL OUTLY LAND BLDG & EQUIP	0.00	39,395.00	0.00	0.00	96.03	37,830.11	1,564.89
240	35	-- FOOD SERVICES	3,633,083.00	3,774,083.00	293,248.36	2,005,459.47	54.95	68,462.77	1,700,160.76
51		PLANT MAINTENANCE & OPERATIONS							
240	51	61 PAYROLL COSTS	7,100.00	6,100.00	0.00	0.00	0.00	0.00	6,100.00
240	51	62 PURCHASE & CONTRACTED SVS	50,000.00	51,000.00	80.00	390.67	0.77	0.00	50,609.33
240	51	-- PLANT MAINTENANCE & OPERATIONS	57,100.00	57,100.00	80.00	390.67	0.68	0.00	56,709.33
240	--	-- Expense	3,690,183.00	3,831,183.00	293,328.36	2,005,850.14	54.14	68,462.77	1,756,870.09
240	--	-- FOOD SERVICE	188,233.00	62,233.00	36,307.01	305,366.58	380.67	-68,462.77	-174,670.81

Comparison of Revenues and Expenditures to Budget (Date: 3/2021)

FUND	FUNC	OB	OBJ	2020-21	2020-21	March 2020-21	2020-21	2020-21	Encumbered	Unencumbered
				Original Budget	Revised Budget	Monthly Activity	FYTD Activity	FYTD %	Amount	Balance
599			DEBT SERVICE							
R			Revenue							
00										
599	00	57	REVENUE-LOCAL & INTERMED	28,229,986.00	28,229,986.00	1,544,923.97	27,802,077.38	98.48	0.00	427,908.62
599	00	58	STATE PROGRAM REVENUES	407,464.00	407,464.00	0.00	183,245.00	44.97	0.00	224,219.00
599	00	79	OTHER RESOURCES	0.00	152,882,272.00	0.00	152,882,270.95	100.00	0.00	1.05
599	00	--		28,637,450.00	181,519,722.00	1,544,923.97	180,867,593.33	99.64	0.00	652,128.67
599	--	--	Revenue	28,637,450.00	181,519,722.00	1,544,923.97	180,867,593.33	99.64	0.00	652,128.67

Comparison of Revenues and Expenditures to Budget (Date: 3/2021)

FUND	FUNC	OB	OBJ	2020-21	2020-21	March 2020-21	2020-21	2020-21	Encumbered	Unencumbered
				Original Budget	Revised Budget	Monthly Activity	FYTD Activity	FYTD %	Amount	Balance
599			DEBT SERVICE							
E			Expense							
00										
599	00	89	OTHER USES	2,293,302.00	118,962,545.00	0.00	118,962,544.14	100.00	0.00	0.86
599	00	--		2,293,302.00	118,962,545.00	0.00	118,962,544.14	100.00	0.00	0.86
71			DEBT SERVICES							
599	71	65	DEBT SERVICE	26,344,148.00	63,573,757.00	750.00	63,569,750.42	100.00	4,000.00	6.58
599	71	--	DEBT SERVICES	26,344,148.00	63,573,757.00	750.00	63,569,750.42	100.00	4,000.00	6.58
599	--	--	Expense	28,637,450.00	182,536,302.00	750.00	182,532,294.56	100.00	4,000.00	7.44
599	--	--	DEBT SERVICE	0.00	-1,016,580.00	1,544,173.97	-1,664,701.23	164.15	-4,000.00	652,121.23

Comparison of Revenues and Expenditures to Budget (Date: 3/2021)

FUND	FUNC	OB	OBJ	2020-21	2020-21	March 2020-21	2020-21	2020-21	Encumbered	Unencumbered	
				Original Budget	Revised Budget	Monthly Activity	FYTD Activity	FYTD %	Amount	Balance	
				Grand Revenue Totals	128,813,785.00	285,561,985.00	5,996,933.43	258,959,199.29	90.65	-93,080.18	26,695,865.89
				Grand Expense Totals	128,625,552.00	288,596,538.00	8,893,135.82	251,546,444.48	88.63	4,227,741.36	32,822,352.16
				Grand Totals	188,233.00	3,034,553.00	2,896,202.39	7,412,754.81	-244.28	4,320,821.54	6,126,486.27
				Profit		Loss	Loss	Profit		Loss	Loss

Number of Accounts: 5701

\*\*\*\*\* End of report \*\*\*\*\*

**Projected Capital Project Needs  
As of October 19, 2020  
Fund Balance Report**

	2016 Bonds	General Fund Balance-Assigned for Construction	Nonspendable Fund Balance for Inventories and Prepaid Items	Committed Fund Balance for Capital Expenditures & Equipment	Unassigned Fund Balance	Total Fund Balance
Current Year Capital Expenditures and Equipment <b>Audited June 30, 2020 Balance</b>	\$ 126,099,903	\$ 13,500,000	\$ 47,633	\$ 3,167,888	\$ 15,453,365	\$ 32,168,886
Current Year Adjustments to Fund Balance				5,898,846	(5,898,846)	-
July - September Interest Revenue	58,442					
July - September Expenses	(7,158,045)					
	(7,099,603)	-	-	5,898,846	(5,898,846)	-
<b>Estimated Balances as of October 19, 2020</b>	<b>\$ 119,000,300</b>	<b>\$ 13,500,000</b>	<b>\$ 47,633</b>	<b>\$ 9,066,734</b>	<b>\$ 9,554,519</b>	<b>\$ 32,168,886</b>
<b>Other Proposed Projects for Transportation, Athletics, Maintenance and Technology (Replacement Schedules)</b>						
Fiscal Year 2020-21				9,066,734		9,066,734
Fiscal Year 2021-22					7,813,918	7,813,918
Fiscal Year 2022-23					364,541	364,541
Fiscal Year 2023-24					508,957	508,957
Fiscal Year 2024-25					650,394	650,394
Total Est. Project Costs Fiscal Years 2021-25		-	-	9,066,734	9,337,810	18,404,544
<b>Estimated Balances as of June 30, 2025</b>		<b>\$ 13,500,000</b>	<b>\$ 47,633</b>	<b>\$ -</b>	<b>\$ 216,709</b>	<b>\$ 13,764,342</b>

**Recommendations for 2020-21 Fund Balance Uses**

**COVID Expenses**

**Approved at July 20, 2020 Board Meeting**

EPSLA 3 additional days	\$ 450,000
15 Full Time Substitutes	400,000
Proctor Substitutes	100,000
30 Custodians	810,000
Buses	394,228

**Approved at August 4, 2020 Board Meeting**

ZOOM webinar service for virtual classroom instruction	70,000
Proctoria Solutions for proctoring virtual learning	65,000

**Replacement Schedules 2020-2021**

Band Instruments per replacement schedule	97,856
Athletics per replacement schedule	25,000
Maintenance per replacement schedule	6,454,650
Technology per replacement schedule	200,000
Total Estimated Capital Projects	<u>\$ 9,066,734</u> ~

**FIRST FINANCIAL BANK**

March 2021 Statement

Page 1 of 3

Open Date: 02/03/2021 Closing Date: 03/03/2021

Account:



Visa® Community Card  
MIDLOTHIAN IDS

Cardmember Service  
BUS 30 ELN 6

1-866-552-8855  
2

<b>New Balance</b>	<b>\$954.90</b>
<b>Minimum Payment Due</b>	<b>\$954.90</b>
<b>Payment Due Date</b>	<b>04/01/2021</b>

Late Payment Warning: As a reminder, your card is a pay in full product. If we do not receive your payment in full by the date listed above, a fee of either 3.00% of the payment due or \$39.00 minimum, whichever is greater, will apply.

<b>Activity Summary</b>		
Previous Balance	+	\$954.73
Payments	-	\$954.73CR
Other Credits	-	\$80.00CR
Purchases	+	\$1,034.90
Balance Transfers		\$0.00
Advances		\$0.00
Other Debits		\$0.00
Fees Charged		\$0.00
Interest Charged		\$0.00
<b>New Balance</b>	<b>=</b>	<b>\$954.90</b>
<b>Past Due</b>		<b>\$0.00</b>
<b>Minimum Payment Due</b>		<b>\$954.90</b>
Credit Line		\$20,000.00
Available Credit		\$19,045.10
Days in Billing Period		29

RECEIVED  
MAR 03 2021  
BUSINESS OFFICE

**Payment Options:**

Mail payment coupon with a check

Pay online at myaccountaccess.com

Pay by phone 1-866-552-8855

Please detach and send coupon with check payable to Cardmember Service CPN 002079425

**FIRST FINANCIAL BANK**

0047985100666022160000954900000954909

24-Hour Cardmember Service: 1-866-552-8855

to pay by phone  
 to change your address

000005875 01 SP 000638743137321 P Y

MIDLOTHIAN IDS  
ACCOUNTS PAYABLE  
100 WALTER STEPHENSON RD  
MIDLOTHIAN TX 76065-3418



Account Number	
Payment Due Date	4/01/2021
New Balance	\$954.90
Minimum Payment Due	\$954.90

Amount Enclosed \$ \_\_\_\_\_

Cardmember Service  
P.O. Box 790408  
St. Louis, MO 63179-0408



**FIRST FINANCIAL BANK**

March 2021 Statement 02/03/2021 - 03/03/2021

Page 2 of 3

MIDLOTHIAN IDS

Cardmember Service

1-866-552-8855



**Important Messages**

Paying Interest: You have a 24 to 30 day interest-free period for Purchases provided you have paid your previous balance in full by the Payment Due Date shown on your monthly Account statement. In order to avoid additional INTEREST CHARGES on Purchases, you must pay your new balance in full by the Payment Due Date shown on the front of your monthly Account statement.

There is no interest-free period for transactions that post to the Account as Advances or Balance Transfers except as provided in any Offer Materials. Those transactions are subject to interest from the date they post to the Account until the date they are paid in full.

Speed through checkout with the added security and convenience of PayPal. Go to the Mobile App or manage your account online. Link your card to PayPal today.

We have added Mobile Authentication and Cellular Phone Contact Policy to and made changes to the Arbitration Agreement in your account agreement. Please visit [card.myaccountaccess.com/agreementchanges](http://card.myaccountaccess.com/agreementchanges) to review. If you have any questions, call the number on the back of your card.

Transactions		NORRIS, JAMES T		Credit Limit	\$20000
Post Date	Trans Date	Ref #	Transaction Description	Amount	Notation
<b>Other Credits</b>					
02/11	02/10	8092	TCU MARKETPLACE ECOMM FORT WORTH TX MERCHANDISE/SERVICE RETURN	\$80.00	CR ✓
<b>Purchases and Other Debits</b>					
02/08	02/05	0121	TX OAG OPEN RECORDS EGOV.COM TX	\$15.00	1 ✓
02/10	02/09	1510	BAYLOR U - HANDSHAKE HTTPSAPP.JOIN CA	\$100.00	2 ✓
02/10	02/09	4653	UT SAN ANTONIO-HNDSHKE HTTPSJOINHAND CA	\$175.00	3 ✓
02/11	02/10	0728	TSU - 04 - HANDSHAKE - 254-968-9078 TX	\$100.00	4 ✓
02/16	02/12	7128	UTA CAREER DEVELOPMENT 817-2720263 TX	\$225.00	5 ✓
02/16	02/12	8007	SHUTTERFLY 800-986-1065 CA	\$419.90	6 ✓
Total for Account 4798 5100 6660 2224				\$954.90	

Transactions		BILLING ACCOUNT ACTIVITY		Amount	Notation
Post Date	Trans Date	Ref #	Transaction Description	Amount	Notation
<b>Payments and Other Credits</b>					
02/16	02/13	0032	PAYMENT THANK YOU	\$954.73	CR
Total for Account 4798 5100 6660 2216				\$954.73	CR

<b>2021 Totals Year-to-Date</b>	
Total Fees Charged in 2021	\$0.00
Total Interest Charged in 2021	\$0.00

Continued on Next Page

Mar-21	DATE	VENDOR	ORGANIZATION	DESCRIPTION	ACCOUNT	AMOUNT	
	5-Feb	TX OAD OPEN RECORDS	T. MCGREW	OAG REQUEST - PROP INFO	199.41.6499.00.701.0.99.701	15	1
	9-Feb	BAYLOR U-HANDSHAKE	HR	VIRTUAL CAREER FAIR - SPRING	199.41.6499.00.749.0.99.749	100	2
	9-Feb	UTSA - HANDSHAKE	HR	VIRTUAL CAREER FAIR - SPRING	199.41.6499.00.749.0.99.749	175	3
	10-Feb	TSU-04-HANDSHAKE	HR	VIRTUAL CAREER FAIR - SPRING	199.41.6499.00.749.0.99.749	100	4
	12-Feb	UTA CAREER DEVELOP	HR	VIRTUAL CAREER FAIR - SPRING	199.41.6499.00.749.0.99.749	225	5
	12-Feb	SHUTTERFLY	T. MCGREW	PRINTING OFFICE PICTURES	461.41.6299.00.999.0.99.000	419.9	6
	10-Feb	TCU MARKETPLACE	HR - CREDIT	JOB FAIR MARCH 23, 2021	199.41.6411.00.749.0.99.749	-80	7
						954.9	

Midlothian ISD  
 Bond Expenditures Update  
 As of March 31, 2021

Bond Election	Project	Original Budget	Revised Budget	Expenditures	Committed	Earned Interest	Available Funds
<b>Nov 2016</b>							
<b>Fund 694</b>	<b>HVAC Replacement</b>						
	Longbranch Elementary	\$ 1,300,000	\$ 1,690,354	\$ 1,690,354	\$ -	\$ -	\$ (0)
	Mt. Peak Elementary	\$ 1,300,000	\$ 1,737,819	\$ 1,737,819	\$ -	\$ -	\$ 0
	MISD Auxiliary Facility	\$ 400,000	\$ 443,981	\$ 443,982	\$ -	\$ -	\$ (0)
	Vitovsky Elementary		\$ 2,466,305	\$ 2,461,757	\$ 4,548	\$ -	\$ 0.00
	<b>Irvin Elementary Rebuild</b>	\$ 28,000,000	\$ 23,988,373	\$ 23,955,911	\$ 32,462	\$ -	\$ 0.00
	Land Purchase		\$ 919,956	\$ 919,956		\$ -	\$ -
	<b>Technology Upgrades</b>	\$ 18,000,000	\$ 18,000,000	\$ 13,773,083	\$ 808,664	\$ -	\$ 3,418,253
	<b>Dieterich Middle School (MS #3)</b>	\$ 67,000,000	\$ 59,485,080	\$ 58,120,896	\$ 1,280,960	\$ -	\$ 83,224
	<b>Renovate MS Playing Fields</b>						
	Frank Seale MS	\$ 2,000,000	\$ 1,904,176	\$ 1,904,176	\$ -	\$ -	\$ (0)
	Walnut Grove MS	\$ 2,000,000	\$ 1,588,827	\$ 1,588,827	\$ -	\$ -	\$ 0
	<b>MHS Baseball/Softball/Tennis/FH</b>	\$ 6,000,000	\$ 12,616,393	\$ 12,616,393	\$ -	\$ -	\$ -
	Land Purchase		\$ 919,956	\$ 919,956		\$ -	\$ -
	<b>Roesler Fieldhouse / Fields</b>	\$ 25,000,000	\$ 15,009,673	\$ 15,009,673	\$ -	\$ -	\$ 0.00
	<b>Renovations to Existing Campuses</b>	\$ 10,000,000	\$ -	\$ -	\$ -	\$ -	\$ -
	Baxter Elementary		\$ 1,067,118	\$ 1,067,118	\$ -	\$ -	\$ -
	Longbranch Elementary		\$ 772,039	\$ 772,039	\$ -	\$ -	\$ -
	Mt. Peak Elementary		\$ 774,701	\$ 774,701	\$ -	\$ -	\$ -
	Vitovsky Elementary		\$ 766,564	\$ 766,564	\$ -	\$ -	\$ -
	Miller Elementary		\$ 747,959	\$ 747,959	\$ -	\$ -	\$ 0
	Frank Seale Middle School		\$ 1,177,790	\$ 1,177,790	\$ -	\$ -	\$ -
	Walnut Grove Middle School		\$ 1,179,463	\$ 1,179,463	\$ -	\$ -	\$ -
	Midlothian High School		\$ 2,428,346	\$ 2,428,346	\$ -	\$ -	\$ 0
	Heritage High School		\$ 11,880	\$ 11,880	\$ -	\$ -	\$ -
	MHS Auditorium		\$ 939,502	\$ 897,356	\$ 42,146	\$ -	\$ 0
	<b>Roof Replacement</b>						
	Longbranch Elementary	\$ 500,000	\$ 350,031	\$ 350,031	\$ -	\$ -	\$ -
	Mt. Peak Elementary	\$ 500,000	\$ 350,031	\$ 350,031	\$ -	\$ -	\$ -
	Vitovsky Elementary	\$ -	\$ 349,902	\$ 349,902	\$ -	\$ -	\$ -
	<b>MILE &amp; Jenkins (Irvin Renovations)</b>	\$ 2,000,000	\$ 5,402,170	\$ 5,379,987	\$ 22,183	\$ -	\$ 0
	<b>Randall Hill Support Center (Jenkins)</b>	\$ 1,000,000	\$ 2,000,000	\$ 939,839	\$ 944,598	\$ -	\$ 115,563
	<b>Elementary #8</b>	\$ 32,000,000	\$ 30,000,000	\$ 1,000,239	\$ 1,309,259	\$ -	\$ 27,690,502
	<b>Multi-Purpose Stadium</b>	\$ 3,000,000	\$ 3,000,000	\$ -	\$ -	\$ -	\$ 3,000,000
	<b>Heritage HS Additions</b>	\$ 68,000,000	\$ 63,659,470	\$ 15,176,410	\$ 42,356,084	\$ -	\$ 6,126,975
	<b>Land - School Sites</b>	\$ -	\$ 426,861	\$ 426,861	\$ -	\$ -	\$ (0)
	<b>Special Projects/Paid by Interest</b>						
	Longbranch Elementary Parking		\$ 787,119.97	\$ 787,120	\$ -	\$ -	\$ -
	Mt. Peak Elementary Parking		\$ 525,366.93	\$ 525,367	\$ -	\$ -	\$ 0
	Baxter Video Marquee		\$ 34,064.34	\$ 34,064	\$ -	\$ -	\$ -
	Vitovsky Video Marquee		\$ 35,264.34	\$ 35,264	\$ -	\$ -	\$ -
	Longbranch Video Marquee		\$ 34,995.00	\$ -	\$ 34,995	\$ -	\$ -
	Mt. Peak Video Marquee		\$ 34,995.00	\$ -	\$ 34,995	\$ -	\$ -
	MISD Stadium Concessions		\$ 62,287.30	\$ 62,287	\$ -	\$ -	\$ -
	FSMS Bus Drive		\$ 180,993.69	\$ 180,994	\$ -	\$ -	\$ -
	MHS Arena		\$ 50,200.00	\$ 3,750	\$ 46,450	\$ -	\$ -
	Old Bus Barn Demo		\$ 18,500.00	\$ -	\$ 18,500	\$ -	\$ -
	<b>Unallocated</b>	\$ -	\$ 11,825,279	\$ -	\$ -	\$ -	\$ 11,825,279
	<b>Earned Interest</b>	\$ -	\$ (1,763,787)	\$ -	\$ -	\$ 4,694,864	\$ 2,931,077
	<b>Total</b>	<b>\$ 268,000,000</b>	<b>\$ 268,000,000</b>	<b>\$ 170,568,147</b>	<b>\$ 46,935,844</b>	<b>\$ 4,694,864</b>	<b>\$ 55,190,873</b>

Cash Recap	Sources	Expenditures	Earned Interest
2017-A Bonds	\$ 28,000,000		
2017-B Bonds	\$ 40,000,000		
2018 Bonds	\$ 80,000,000		
2020 Bonds	\$ 120,000,000		
<b>Totals</b>	<b>\$ 268,000,000</b>	<b>\$ 170,568,147</b>	<b>\$ 4,694,863.98</b>
			<b>Cash Balance \$ 102,126,717</b>
			<b>TexPool Balance \$ 102,126,715</b>