

Agenda

1. Call the meeting to order
2. Open Meetings Law
3. Roll Call
4. Consent Agenda
 - 4.1. Approval of Minutes
 - 4.2. Approval of General Fund Bills
 - 4.3. Approval of Board Member Absence
5. Treasurer's report
6. Recognition of Students and Staff
7. Recognition of Visitors/Public Comment
8. ACTION ITEMS
 - 8.1. Set the limit of special education students for the purpose of option enrollment at 100 students district wide for the 2026-2027 school year
 - 8.2. Set the limit of class size in the elementary at __ per grade level for the purpose of option enrollment
 - 8.3. Reallocate depreciation funds for the purpose of purchasing a replacement oven/stove combo unit and necessary accessories for the kitchen
9. DISCUSSION ITEMS
 - 9.1. THS Facilities Use for 2026-2027
10. Principal Reports
 - 10.1. Elementary Principal
 - 10.2. Secondary Principal
11. Board Reports
 - 11.1. Buildings, Grounds, and Transportation Committee Report
12. Superintendent Report
13. Next meeting date and time: Monday, April 13th, 2026, at 5:30 pm.
14. Adjournment

Board of Education Regular Meeting
Monday, February 9, 2026 5:30 PM Central

Tekamah-Herman Public Schools
112 N 13th St
Tekamah, NE 68061

Chris Booth: Present
Abby Mathistad: Present
Mandyn Pruess: Present
Burt Rogers: Present
Bill Skinner: Present
Sheryl Stansberry: Present
Present: 6.

1. Call the meeting to order

2. Open Meetings Law

3. Roll Call

4. Consent Agenda

The motion to approve the Consent Agenda as presented Passed with a motion by Burt Rogers and a second by Sheryl Stansberry.

Chris Booth: Yea, Abby Mathistad: Yea, Mandyn Pruess: Yea, Burt Rogers: Yea, Bill Skinner: Yea, Sheryl Stansberry: Yea
Yea: 6, Nay: 0

4.1. Approval of Minutes

4.2. Approval of General Fund Bills

4.3. Approval of Board Member Absence

5. Treasurer's report

Mr. Kjar reviewed the December 2025 Treasurer's report with the Board.

6. Recognition of Students and Staff

Mrs. Beck reported that starting in January, the elementary has transitioned their Student of the Month recognition to Student Spotlight. Student spotlight gives our teachers a chance to recognize students with specific positive feedback for meeting our schoolwide expectations. Also congratulations to Ellen Eriksen! Mrs. Eriksen was selected by KTIC radio as the teacher of the week during the last week of January.

Mr. Heitz recognized the state girls wrestling qualifiers, EHC Honor Band and the FFA State Qualifiers.

7. Recognition of Visitors/Public Comment

None

8. ACTION ITEMS

8.1. Approve lathes, planer, lawn tractor, and ice machine as surplus for immediate sale or disposal

The motion to approve lathes, planer, lawn tractor, and ice machine as surplus for immediate sale or disposal Passed with a motion by Chris Booth and a second by Bill Skinner.

Chris Booth: Yea, Abby Mathistad: Yea, Mandyn Pruess: Yea, Burt Rogers: Yea, Bill Skinner: Yea, Sheryl Stansberry: Yea

Yea: 6, Nay: 0

8.2. Approve the 2026-2027 THS School Calendar

The motion to approve the 2026-2027 THS school calendar as presented Passed with a motion by Burt Rogers and a second by Abby Mathistad.

Chris Booth: Yea, Abby Mathistad: Yea, Mandyn Pruess: Yea, Burt Rogers: Yea, Bill Skinner: Yea, Sheryl Stansberry: Yea

Yea: 6, Nay: 0

8.3. Re-allocate ear-marked depreciation funds

The motion to reallocate earmarked depreciation funds: \$1,324 for the purchase of a replacement ice maker and \$3,165 for replacement/reconditioning of football helmets Passed with a motion by Chris Booth and a second by Sheryl Stansberry.

Chris Booth: Yea, Abby Mathistad: Yea, Mandyn Pruess: Yea, Burt Rogers: Yea, Bill Skinner: Yea, Sheryl Stansberry: Yea

Yea: 6, Nay: 0

8.4. Approve Eli Lingle as a substitute teacher

The motion to approve Eli Lingle as a substitute teacher Passed with a motion by Sheryl Stansberry and a second by Chris Booth.

Chris Booth: Yea, Abby Mathistad: Yea, Mandyn Pruess: Yea, Burt Rogers: Yea, Bill Skinner: Yea, Sheryl Stansberry: Yea

Yea: 6, Nay: 0

9. DISCUSSION ITEMS

9.1. THS Facilities Use for 2026-2027

Mr. Kjar presented the proposed Facilities Use Agreement/Policy that the District would like to put into place. Mr. Kjar asked the Board to please take some time to review.

10. Principal Reports

10.1. Elementary Principal

Mrs. Beck's elementary report showed enrollment remains fairly steady at 287 students. The Nebraska Reading Improvement Act has been in place for several years, and requires us to identify, and then intervene for students who are below the benchmark in the area of reading. Beck reported that after our mid-year screening of students, we've seen great growth. Beck provided the Board with a chart by grade showing the improvement in reading plans.

10.2. Secondary Principal

Mr. Heitz informed the Board that he attended the Wayne State Career Fair where he spoke to tons of students in the field of education. We currently do not have any openings, however, he said it was good to make connections and see if anyone is interested in settling in our area after they graduate. Heitz spoke about the Practice ACT test that he performed in an effort to

get the juniors more comfortable as the real test is approaching on March 24th. Heitz also reported that the musical "Mean Girls" will be performed on March 5, 6, and 7th.

11. Board Reports

11.1. Building, Grounds, Transportation Committee

The Building and Grounds committee have been working on finalizing the construction projects that are on the books to begin this spring. The first phase is a new building at Tiger Stadium. This building will consist of ADA-compliant bathrooms, a concessions area, locker room, team room and the ticket booth. This building would replace the field house in the city park. The current structure at the field will be upgraded to all storage. The second phase of the project is a space update for our Elementary and Life Skills students. The unofficial plan shows converting the current 5th and 6th grade rooms into Special Ed space and closing in the back portion of the slab, creating 4 classrooms and storage areas.

12. Superintendent Report

Mr. Kjar reported LB 1038 information regarding a new school finance model-there will be more information to come as it is still unclear what the plan all involves. Kjar has done the prep work and has received the door decals to number our exterior doors. Kjar also reported bus no. 12 had exhaust pipe repairs.

13. Adjournment

The motion to adjourn the meeting at 6:39pm Passed with a motion by Chris Booth and a second by Bill Skinner.

Chris Booth: Yea, Abby Mathistad: Yea, Mandyn Pruess: Yea, Burt Rogers: Yea, Bill Skinner: Yea, Sheryl Stansberry: Yea

Yea: 6, Nay: 0

14. Next meeting date and time: Monday, March 9th, 2026 at 5:30 pm in the THS Library

Tekamah-Herman Public Schools

14627	FIRST NATIONAL BANK	62.14
14628	FIRST NATIONAL BANK	745.14
14629	VESTIS	193.99
AUTO	RISE BROADBAND	110.19
AUTO	CREXENDO	1317.63
145645	ACCESS SYSTEM LEASING	2,406.70
145646	ACCESS SYSTEMS TC50	114.89
145647	AFP WEST CORPORATION	504.00
145648	AJ'S SERVICE AND REPAIR	595.79
145649	Allison Electric	191.10
145650	AMAZON CAPITAL SERVICES, INC	1,839.04
145651	ARR-BOONE BROTHERS ROOFING	536.25
145652	BOMGAARS SUPPLY INC	253.92
145653	BRANIFF SERVICE	797.18
145654	BRUMMOND DISPOSAL LLC	425.00
145655	BUDDIES RENTALS	600.00
145656	BURT COUNTY INDEPENDENT	266.43
145657	CAPITAL SANITARY SUPPLY	2,239.41
145658	CAROLINA BIOLOGICAL SUPPLY CO	61.22
145659	CENTURYLINK	554.63
145660	CIACCIO ROOFING	388.53
145661	CITY OF TEKAMAH	167.00
145662	CITY WIDE FACILITY SOLUTIONS	23,520.00
145663	CRAIG RESOURCES INC, DBA CRAIG	5,220.60
145664	Cubby's, Inc.	93.55
145665	ESU #2	85.00
145666	Julie Fleischman	28.26
145667	BRI HANSEN	102.23
145668	JARED KRAUSE	217.50
145669	KSB SCHOOL LAW, PC LLO	1,600.50
145670	HOLLY LOFTIS	174.00
145671	MATHESON TRI-GAS, INC	4,519.53
145672	Menards	52.78
145673	MOSYLE CORPORATION	112.50
145674	NEBRASKA PUBLIC POWER	3,900.00
145675	Nebraska Rural Community School	100.00
145676	NEBRASKA SAFETY CENTER	250.00
145677	ONE OFFICE SOLUTION	449.38
145678	OneSource	22.00
145679	BRAD PAUL	17.20
145680	RUTT'S MECHANICAL SERVICES	2,250.00
145681	SAVEMORE MARKET	95.32
145682	SCHOOL NURSE SUPPLY, INC	114.91
145683	SCHOOLS PLP, LLC.	3,810.00
145684	Security Equipment Inc.	644.90
145685	BOB SWANBERG	5.91
145686	Tekamah-Herman Schools	2,600.00
145687	VERIZON WIRELESS	90.32
145688	VESTIS	291.36
145689	WALTER LYDICK	6,300.00
145690	WOODRIVER ENERGY LLC	9,759.75
	BRIDGET ABRAHAM	99.76
	MANNI BELFRAGE	43.50
	VANESSA BRAND	174.00
	CARRIE BRANIFF	47.85
	BRIDGETTE BRAYMEN	141.38
	Abra Bridges	152.25
	CARI BRODERSEN	152.25
	ANDREA BROMM	87.00
	JAMIE BRUMMOND	108.75
	SARAH BRUSEGAARD	252.56
	WES OR LISA BURT	130.50
	SABINA CAMERON	108.75
	JILL CONNEALY	152.25
	ERIC OR CLARITY DEVNEY	207.35
	KENDAL DORN	41.33
	ROBERT & BREANNE EVASIC	115.28
	ASHLEY FISHER	130.50
	DEANNA GOODWIN	195.75
	JOEL HAMAN	1,208.49
	AMANDA HANSEN	76.13
	CHELSEA HANSEN	95.41
	JON HANSEN	110.93

LINDSEY HANSEN	87.00
BUCK OR ALLIE HOIER	76.13
MACKENZIE KAHLANDT	204.45
JAMES KELLY	152.25
PAIGE KNAUSS	261.00
TIMOTHY OR GINA LANDSPERGER	60.90
KATIE LEICHLER	261.00
BLAIR MAGILL	130.50
MICHAELA MANN	108.75
TIFFANY MARQUARDT	117.45
ABBY MATHISTAD	152.25
LAURA MCELMURAY	80.48
CARISSA OR ANDY OLIGMUELLER	30.45
RYANN PAGELS	182.70
JACOB OR TIFFANY PETTIT	195.75
JENNIFER POTADLE	28.28
BRITTANY RAY	134.85
DANIELLE ROBERTS	115.28
JESSICA SATORIE	174.00
JODIE SCHUETT	143.55
SHAUNA SELF	302.33
AARON SNOW	87.00
JILL SPENNER	174.00
SEAN THIEMANN	180.53
MICHELLE TOBIN	188.79
ASHLEY TYSON	174.00
ASHLEY WIMER	56.55
HAILEY WOLF	276.23
KILEY WORLEY	261.00

TOTAL \$	<u>89,027.10</u>
----------	------------------

BUILDING FUND

1773	CARLSON WEST POVONDRA	<u>38,457.90</u>
TOTAL \$		38,457.90

GENERAL FUND		
Jan-26		
CASH ON HAND	\$ 2,103,168.42	
GENERAL REIMBURSEMENT FUND	\$ 26,174.83	
PAY FLEX	\$ 18,482.18	
CASH BALANCE		\$ 2,129,343.25
BURT COUNTY TAXES	\$ 1,296,038.53	
WASHINGTON COUNTY TAXES	\$ 44,336.48	
SPEC ED PROGRAMS	\$ 153,782.00	
SPED IDEA	\$ 129,951.00	
MEDICAID	\$ 431.16	
WORKMAN'S COMP ADJUSTMENT	\$ 2,693.00	
STATE APPORTIONMENT	\$ 121,251.45	
STATE AID	\$ 83,822.00	
LOCAL RECEIPTS	\$ 5,138.92	
INTEREST	\$ 1,375.31	
	T. REVENUE	\$ 1,838,819.85
		\$3,968,163.10
PAYROLL	\$ 614,269.71	
EXPENDITURES	\$ 80,976.06	
	T. EXPENDITURES	\$ 695,245.77
Ending Balance 1/31/2026		\$3,272,917.33
DEPRECIATION FUND		
Jan-25		
CASH ON HAND	\$ 193,092.92	
CASH BALANCE		\$ 193,092.92
TRANSFER		
INTEREST	\$ 395.17	\$ 395.17
	TOTAL REVENUE	\$193,488.09
EXPENDITURES	\$ 3,165.60	
	TOTAL EXPENDITURES	\$ 3,165.60
Ending Balance 1/31/2026		\$190,322.49
EMPLOYEE BENEFIT FUND		
Jan-26		
CASH ON HAND	\$ 48,907.13	
CASH BALANCE		\$ 48,907.13
INTEREST	\$ 100.49	
		\$ 100.49

	TOTAL REVENUE	\$ 49,007.62
EXPENDITURES		
	TOTAL EXPENDITURE	\$ -
ENDING BALANCE 1/31/2026		\$49,007.62
ACTIVITY FUND		
Jan-26		
CASH ON HAND	\$ 91,952.09	
CASH BALANCE		\$ 91,952.09
DEPOSITS	\$ 32,167.70	
INTEREST	\$ 201.15	
		\$ 32,368.85
TOTAL REVENUE		\$124,320.94
EXPENDITURES	\$ 33,943.29	
	TOTAL EXPENDITURE	\$ 33,943.29
Ending Balance 1/31/2026		\$90,377.65
LUNCH FUND		
Jan-26		
CASH ON HAND	\$ 74,424.99	
CASH BALANCE		\$ 74,424.99
DEPOSITS	\$ 22,415.88	
INTEREST	\$ 165.52	
		\$ 22,581.40
	TOTAL REVENUE	\$ 97,006.39
PAYROLL	\$ 9,741.90	
EXPENDITURES	\$ 14,804.74	
		\$ 24,546.64
Ending Balance 1/31/2026		\$72,459.75
BOND FUND		
Jan-26		
CASH ON HAND	\$ 1,112,954.52	
CASH BALANCE		\$ 1,112,954.52
BURT COUNTY TAXES	\$ 64,138.17	
WASHINGTON COUNTY TAXES	\$ 7,203.74	

INTEREST	\$ 2,103.05	
		\$ 73,444.96
	TOTAL REVENUE	\$1,186,399.48
EXPENDITURES		
	TOTAL EXPENDITURE	\$ -
Ending Balance 1/31/2026		\$1,186,399.48
BUILDING FUND		
Jan-26		
CASH ON HAND	\$ 2,446,178.63	
CASH BALANCE		\$ 2,446,178.63
BURT COUNTY TAXES	\$ 115,436.26	
WASHINGTON COUNTY TAXES	\$ 3,522.24	
INTEREST	\$ 12,880.63	
		\$ 131,839.13
	TOTAL REVENUE	\$ 2,578,017.76
EXPENDITURES	\$ -	
	TOTAL EXPENDITURE	\$ -
Ending Balance 1/31/2026		\$ 2,578,017.76

Tekamah-Herman Board Meeting
Elementary Report

3/9/26

Staff and Student Recognition

- Student Spotlight continues for February! In addition to the specific positive feedback, our students are earning a mini flashlight to celebrate their spotlight! Here are a few examples of Student Spotlight:
 - Anthony Belgarde- He is a responsible student who is kind to his peers, and always a joy to be around.
 - Drake Robinson- Improving his letter formation and overall handwriting.
 - Stephen Fleming- He did a fantastic job representing our school at the spelling bee!
- Thank you to Mackenzie Kahlandt for her outstanding work planning our Title I school-wide assembly, and for organizing our One School, One Book reading of *Stuart Little* in January and February. We had several parents attend our assembly, and it was an incredible display of coordination and involvement from our whole school. Thank you Kenzie!

Principal's Report

- Our current enrollment is 285. We had two students transfer out of the district recently.
- Quick update on my therapy dog project: Cooper is doing a great job in his therapy dog training, and we are on track for our first level of certification by the end of April. In June we will certify and insure through [Healing Hearts Therapy Dogs](#). I am very familiar with this organization from my time in Fremont, and they certify and insure most of the therapy dogs in Fremont Public Schools.
 - I hope to ask for board approval on certified therapy dogs in July or August.

Tekamah-Herman Board Meeting
Secondary Report

3/9/26

Staff and Student Recognition

- Boys Wrestling state qualifiers: Landon Burt (3rd place), Hayden Meisenbach, Ryan Roche
- State FFA
- Musical “Mean Girls”
- EHC and District Speech tournament

Principal’s Report

- Missing assignments, grading, end-of-quarter, etc.
- Excessive absences–reports to the County Attorney
- Spring “field trips”
- ACT/Pre-ACT day, March 24
 - No school for grades 7, 8, 12
- We HOST District Music on Friday, April 24
- Graduation is May 9



96 - 1.0 OZ (2

 General Mills

K-12
REGULATION
READY

24OCT2020



TEKAMAH-HERMAN SCHOOLS

Home of the Tigers

This is the "Current Board Policy"
Yellow Highlights are admin edits.

Tekamah-Herman Public Schools Facility Use Application

This form must be completed and submitted to the THS high school office no less than 10 days prior to the event.

Applicant Name ("Applicant"): _____
Organization Name ("Organization"), if applicable: _____
Applicant's Position within Organization: _____
Address: _____
Phone Number: _____ Email: _____
Description of Requested Use: _____

Is your organization a registered 501(c)(3) or other nonprofit? Yes No
Are you charging a fee for your services/event? Yes No
Is your event/service offered to non THS students? Yes No
Does anyone receive personal compensation from your services/event?
 Yes No

Date(s) of Requested Use: _____
Time of Requested Use: _____ to _____
Facility/Room Request, if preferred: _____
Expected Number of Attendees: _____

Check any of the following needs which apply to your request. Note that the district may deem additional services necessary and may require the Applicant/Organization to pay for such services as a condition of use:

- Custodial (set up, tear down, sanitation)
- Kitchen/Kitchen Staff (cooking, food service, clean up)
- Technology Assistance (sound, lighting, presentation)
- Commons Concession Stand Access
- Other: _____

Approval from a THS Head Varsity Coach: _____

Liability Insurance, check applicable:

- I/we have coverage of \$5 million per occurrence.
- I/we have other coverage:

- I/we have no insurance coverage

Terms and Conditions of Use:

1. All users must comply with the school board's facility use and other policies, rules, and regulations. A copy of the board's facility use policy is available upon request.
2. The facilities are closed from 10 PM to 7 AM and may not be used during those hours.
3. The user(s) named above and the individual(s) signing on behalf of the User agree to defend, indemnify, and hold harmless the school district, its employees and agents for any expense, cost, loss, damage, claim, judgment or claims bill incurred or rendered against same, including attorneys' fees and investigation expenses (pre-suit, suit, trial, appeal, and post appeal proceedings) on account of any intentional or negligent acts or omissions of the user or its employees, agents or servants, or any intentional or negligent acts or omissions of the district or its employees, agents or servants arising out of the use of any facility under this agreement.
4. All non-governmental users may be required to provide a certificate of insurance and name the district as an additional insured, on a primary and non-contributory basis, and provide documentation evidencing general liability coverage under an occurrence basis policy, with minimum limits of \$5,000,000.00 per occurrence , combined single limit covering bodily injury, property damage, personal injury, premises, operations, products, completed operations, independent contractors, and contractual liability. These coverage limits may be achieved through a combination of underlying policies and umbrella/excess policies, if preferred. There shall be no exclusions for contracted liability. All governmental users shall provide evidence of insurance or self-insurance to the limits set forth in NEB. REV. STAT. § 13-926.
5. All users are subject to the fee schedule established by the school board, and all Applicants by signing below verify that they have authority to sign this application on behalf of the listed Organization, and all individuals and agents of organizations certify that they have financial means and authorization to pay for the required fees and deposits, if any.

6. Tekamah-Herman Schools activities will always have priority for use of facilities. In the event that a THS activity is scheduled or rescheduled on a date that has been reserved by an outside individual or organization that event may be cancelled or rescheduled. Refunds are not guaranteed.

Fee Structure:

Approved Non-Profit Organization = \$0

Approved For-Profit Organization/Clinician =
\$150 sports season/quarter of the year
\$50 per month
\$10 per day

Approved For-Profit Organization/Clinician with THS Varsity Coach Approval = \$0

*Additional custodial/cleaning charges may apply.

Applicant's Signature: _____

Date: _____

<p><i>For District Use Only</i></p> <p><u>Application</u></p> <ul style="list-style-type: none"><input type="checkbox"/> Denied<input type="checkbox"/> Approved, subject to the following <p><u>Insurance</u></p> <ul style="list-style-type: none"><input type="checkbox"/> User has provided sufficient proof of insurance.<input type="checkbox"/> User must obtain proof of insurance and list district as additional insured.<input type="checkbox"/> Insurance requirements are waived. <p><u>Additional Services Requested/Required</u></p> <ul style="list-style-type: none"><input type="checkbox"/> Custodial: \$ _____<input type="checkbox"/> Kitchen: \$ _____<input type="checkbox"/> Technology: \$ _____<input type="checkbox"/> None <p>Total Fee Required to Grant Use: \$ _____</p>
--

Tekamah-Herman Board Meeting
Elementary Report

3/9/26

Staff and Student Recognition

- Student Spotlight continues for February! In addition to the specific positive feedback, our students are earning a mini flashlight to celebrate their spotlight! Here are a few examples of Student Spotlight:
 - Anthony Belgarde- He is a responsible student who is kind to his peers, and always a joy to be around.
 - Drake Robinson- Improving his letter formation and overall handwriting.
 - Stephen Fleming- He did a fantastic job representing our school at the spelling bee!
- Thank you to Mackenzie Kahlandt for her outstanding work planning our Title I school-wide assembly, and for organizing our One School, One Book reading of *Stuart Little* in January and February. We had several parents attend our assembly, and it was an incredible display of coordination and involvement from our whole school. Thank you Kenzie!

Principal's Report

- Our current enrollment is 285. We had two students transfer out of the district recently.
- Quick update on my therapy dog project: Cooper is doing a great job in his therapy dog training, and we are on track for our first level of certification by the end of April. In June we will certify and insure through [Healing Hearts Therapy Dogs](#). I am very familiar with this organization from my time in Fremont, and they certify and insure most of the therapy dogs in Fremont Public Schools.
 - I hope to ask for board approval on certified therapy dogs in July or August.

Tekamah-Herman Board Meeting
Secondary Report

3/9/26

Staff and Student Recognition

- Boys Wrestling state qualifiers: Landon Burt (3rd place), Hayden Meisenbach, Ryan Roche
- State FFA
- Musical “Mean Girls”
- EHC and District Speech tournament

Principal’s Report

- Missing assignments, grading, end-of-quarter, etc.
- Excessive absences–reports to the County Attorney
- Spring “field trips”
- ACT/Pre-ACT day, March 24
 - No school for grades 7, 8, 12
- We HOST District Music on Friday, April 24
- Graduation is May 9

FLOOR PLAN NOTES:

- GENERAL CONTRACTOR SHALL VERIFY FLOOR ELEVATIONS OF THE EXISTING FACILITY WITH TRANSIT. COORDINATE ACTUAL FLOOR LEVELS WITH CIVIL, ARCHITECTURAL, AND STRUCTURAL PLANS. CONTACT ARCHITECT IMMEDIATELY IF THERE ARE ANY CONFLICTS WITH ACTUAL CONDITIONS.
- ALL DIMENSIONS SHOWN ARE TO THE FACE OF GB OR FACE OF MASONRY, UNLESS OTHERWISE NOTED. SEE WALL/PARTITION TYPES FOR ACTUAL WIDTH AND ADJUST PLANS ACCORDINGLY.
- DOOR OPENINGS NOT LOCATED BY DIMENSIONS SHALL BE CENTERED IN WALL SHOWN OR LOCATED 6" FROM FINISH WALL TO FINISH JAMB. ALWAYS ALLOW A MIN. OF 18" FROM PULL SIDE OF DOOR TO FACE OF ADJACENT SURFACES.
- ALL PUBLIC SPACES WITH GB SHALL BE FINISHED TO A LEVEL 4 FINISH AND PAINTED UNLESS OTHERWISE NOTED. SEE ROOM FINISH SCHEDULE FOR DETAILS.

WALL/PARTITION TYPE NOTES:

- PROVIDE 3" DEEP DEFLECTION TRACT FOR ALL MTL. STUD PARTITIONS THAT EXTEND TO STRUCTURE ABOVE.
- ALTHOUGH NOT SHOWN, PROVIDE SILL GASKETS AT ALL NEW MTL. STUD INTERIOR PARTITIONS.
- ALTHOUGH NOT SHOWN, PROVIDE HORIZONTAL WALL BRACING, SIM. TO SIMPSON STRONG-TIE "SBR" AND "DBR" SPACER BRACERS, AT ALL NEW METAL STUD PARTITIONS PER MFG. REQUIREMENTS.
- TAPE AND SEAL ALL GB WALL INTERSECTION JOINTS.
- PROVIDE FIRE/SMOKE SEALANT AT ALL FIRE/SMOKE WALL PENETRATIONS.

WALL TYPES

- WALL TYPE NOTES:**
- ALL WALLS TO GO TO STRUCTURAL DECKING UNLESS NOTED OTHERWISE. ALLOW FOR 1" VERTICAL MOVEMENT OF THE BUILDING STRUCTURE WITHOUT IMPACTING WALL.
 - FILL AND SEAL ALL IRREGULARITIES AT THE TOP OF WALL. FILL LARGE GAPS WITH INSULATION. USE UL TESTED SYSTEM APPROVED FOR REQUIRED WALL RATING.
 - SEE WALL TYPES & CODE PLAN FOR FIRE RESISTANT STRUCTURES. IF DISCREPANCIES EXIST WITHIN THE DOCUMENTS, PROVIDE FIRE RESISTANT STRUCTURES EVERYWHERE INDICATED UNTIL CLARIFICATION BY THE ARCHITECT IS GIVEN.
 - WALLS NOT TO STRUCTURE TO EXTEND A MINIMUM OF 6" ABOVE CEILING & BE BRACED TO STRUCTURE AT 48" O.C.
 - WALLS THAT RECEIVE SOUND BATTS ARE TO BE SEALED WITH ACOUSTICAL CAULK (UNLESS FIRE CAULKING IS REQUIRED) AT PERIMETER & ALL PENETRATIONS ABOVE OR BELOW CEILING.
 - PROVIDE WOOD BLOCKING, 16 GAUGE SHEET METAL OR GROUTED CELLS AT ALL LOCATIONS TO RECEIVE WALL MOUNTED OBJECTS. WOOD BLOCKING TO BE FIRE TREATED IF USED IN FIRE RATED WALLS.
 - PROVIDE HEADERS OR LINTELS AT ALL OPENINGS.
 - GYPSUM BOARD SURFACES SHALL BE ISOLATED WITH CONTROL JOINTS (C.J.) OR OTHER STRESS RELIEF WHERE:
 - A. WALLS ABUT A DISSIMILAR WALL OR CEILING MATERIAL OR STRUCTURAL ELEMENT.
 - B. CONSTRUCTION CHANGES WITHIN THE PLANE OF THE WALL.
 - C. WALL OR CEILING EXCEEDS THIRTY LINEAR FEET (30).
 - D. CONTROL OR EXPANSION JOINTS OCCUR WITHIN STRUCTURAL ELEMENTS.
 - E. WALLS HAVE PUNCHED OPENINGS SUCH AS DOORS AND WINDOWS.
 - F. AS INDICATED ELSEWHERE IN THE PLANS AND SPECIFICATIONS.
 - IN LIEU OF 5/8" TYPE X GYPSUM BOARD (GB), USE 5/8" MOISTURE-RESISTANT GYPSUM BOARD (MRGB) IN BATHROOMS AND OTHER LOCATIONS PRONE TO MOISTURE.
 - IN LIEU OF 5/8" TYPE X GYPSUM BOARD (GB), TILE BACKING PANELS ARE TO BE 5/8" CEMENT BOARD (CB) IN RESTROOMS AND WET LOCATIONS OR LOCATIONS PRONE TO MOISTURE.
 - IN LIEU OF 5/8" TYPE X GYPSUM BOARD (GB), TILE BACKING PANELS ARE TO BE 5/8" GLASS MAT GYPSUM BOARD (GMB) AT DRY LOCATIONS.

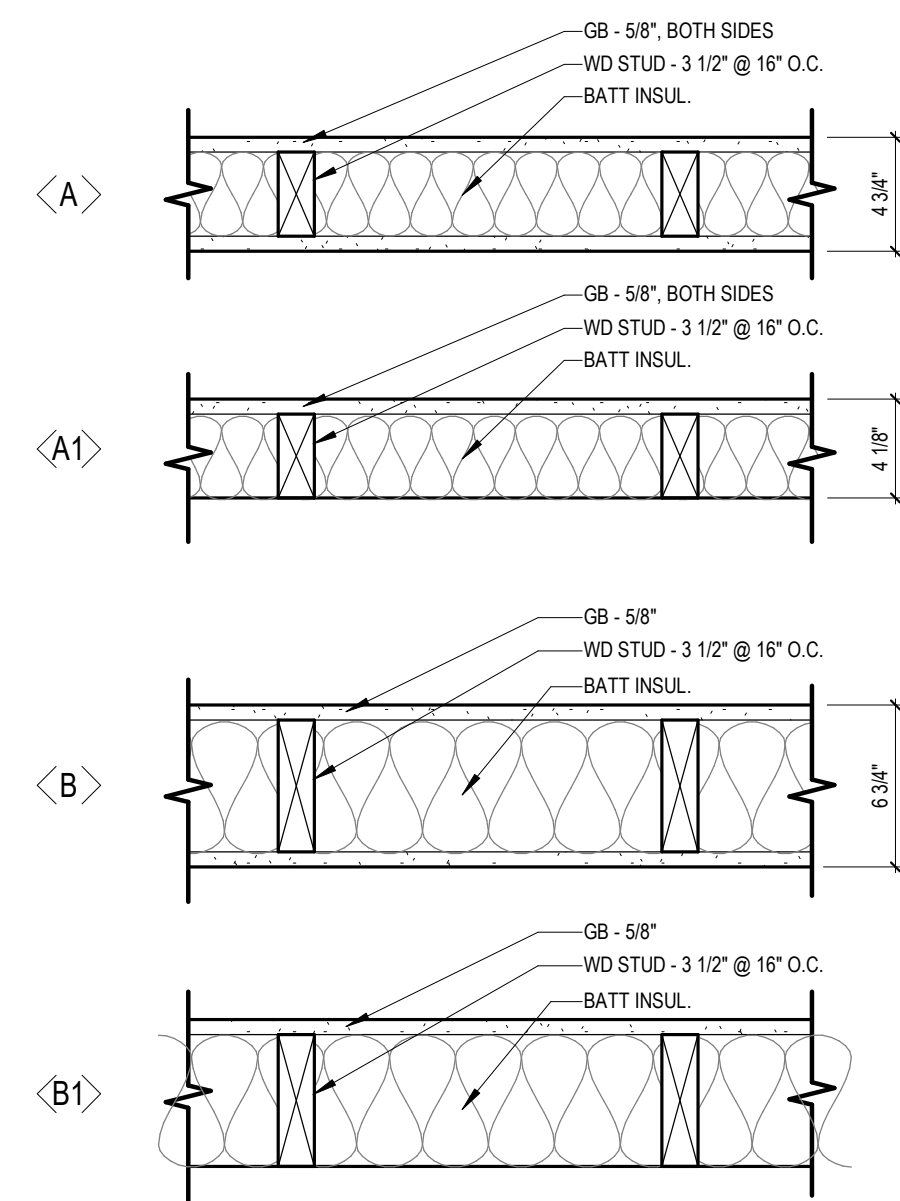

REFLECTIVE CEILING PLAN LEGEND

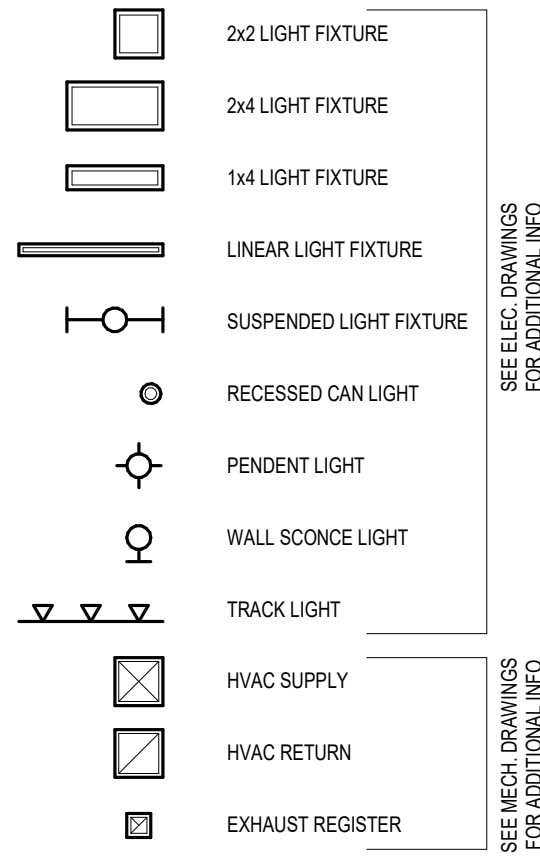

REFLECTED CEILING PLAN GENERAL NOTES

- ALL CEILING GRIDS/PANELS SHALL BE CENTERED IN EACH ROOM UNLESS NOTED OTHERWISE.
- ALL EQUIPMENT, DEVICES, AND FIXTURES SHALL BE CENTERED IN THE CEILING'S TILE UNLESS NOTED OTHERWISE.
- IN AREAS WITH AN EXPOSED STRUCTURE, COORDINATE ALL EQUIPMENT, DEVICES, AND FIXTURES FOR A CLEAN AND ORDERED APPEARANCE.

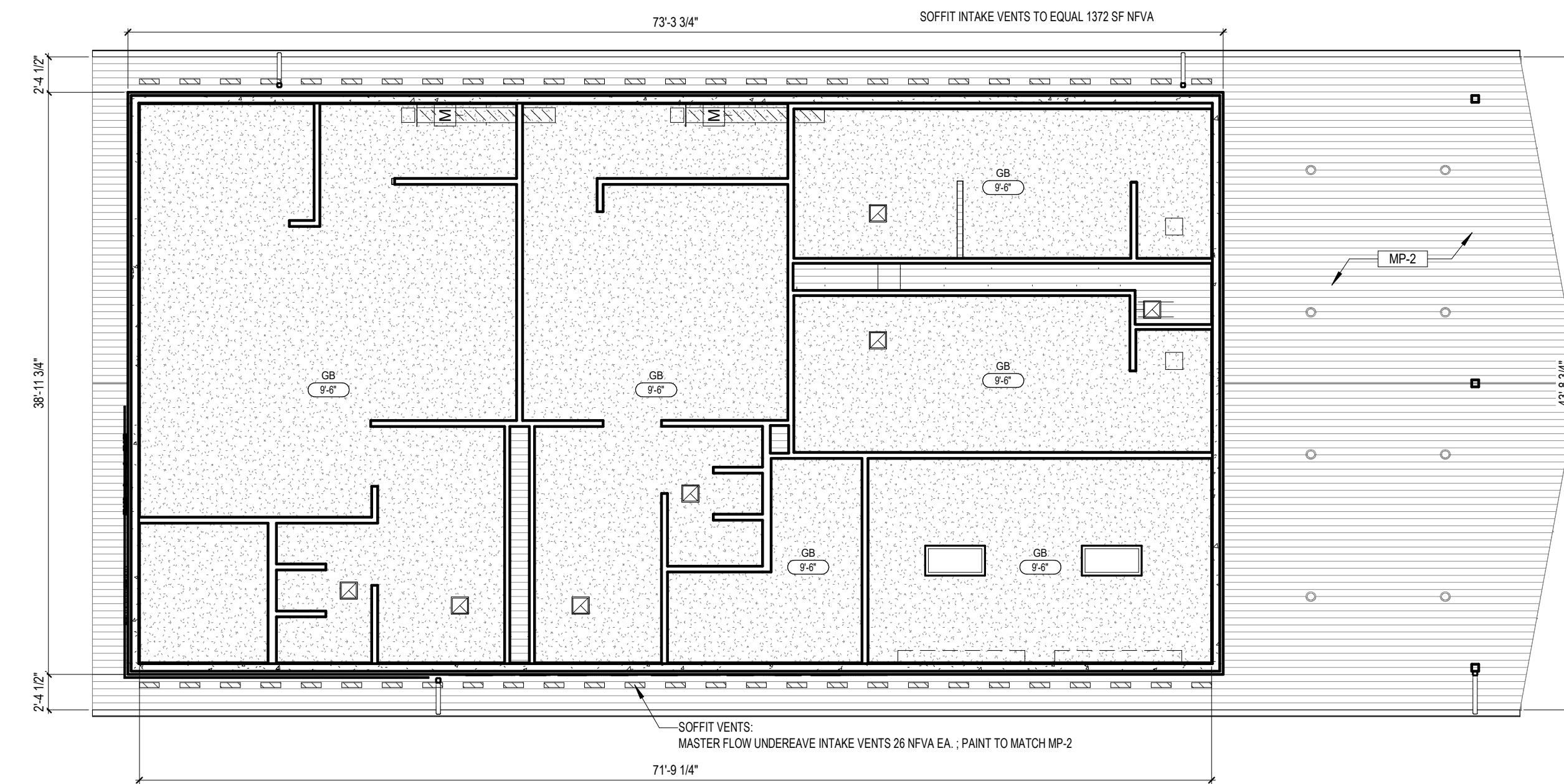
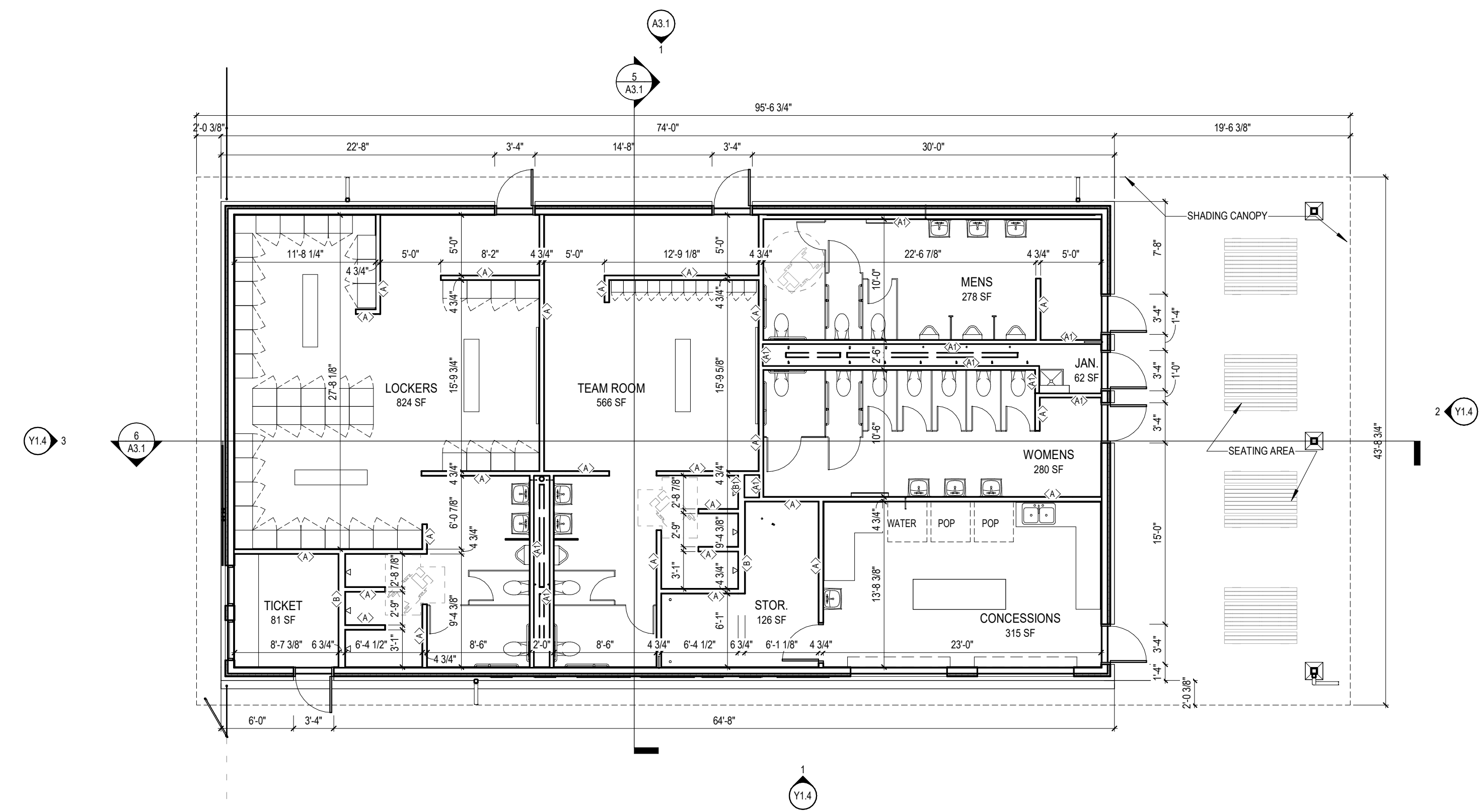

NOT FOR CONSTRUCTION

REVISION SCHEDULE

MARK DESCRIPTION REVISION DATE

FINISH & MATERIAL GENERAL NOTES:

- GENERAL:**
- A. SEE INTERIOR ELEVATIONS, REFLECTED CEILING PLAN (RCP), & FINISHES PLAN FOR ALL LOCATIONS OF MULTIPLE FINISHES.
 - B. VERIFY CONDITIONS OF FLOORS & WALLS SCHEDULE TO RECEIVE NEW FINISHES WITH THE INSTALLER OR PRODUCT MANUFACTURERS' REPRESENTATIVE, PRIOR TO FINISH INSTALLATION. PATCH AND/OR REPAIR HOLES & DEPRESSIONS TO PROVIDE A SMOOTH FINISHED SURFACE.
 - C. INSTALL ALL FINISHES PER MANUFACTURERS' RECOMMENDATIONS, IMMEDIATELY NOTIFY ARCHITECT IN WRITING OF CONDITIONS OF CONSTRUCTION DETRIMENTAL OR PROHIBITIVE TO MANUFACTURER-RECOMMENDED INSTALLATION METHODS.
 - D. FOR ALL MATCH EXISTING FINISHES, MULTIPLE SAMPLES OF DIFFERENT STYLES AND/OR COLORS MAY BE REQUIRED. VERIFY EXACT STYLES & COLORS ON SITE AND SUBMIT SAMPLES FOR ARCHITECT'S APPROVAL PRIOR TO INSTALLATION.
 - E. SEE DOOR & FRAME SCHEDULE FOR PAINT FINISHES ON HM DOORS AND DOOR FRAMES AND COORDINATE WITH MATERIALS SCHEDULE AND SPECIFICATIONS.
 - F. ROOMS NOT LISTED IN THE ROOM FINISH SCHEDULE DO NOT RECEIVE ANY NEW FINISHES; SEE COMPLETE DRAWING SET FOR OTHER MEP OR STRUCTURAL WORK THAT MAY BE OCCURRING WITHIN THOSE SPACES.
- FLOORS:**
- G. FLOOR SURFACES SHOULD HAVE NO MORE THAN 1/4" VARIANCE PER 10 LINEAR FEET WHEN READY TO RECEIVE FINISH MATERIALS. REPAIR EXISTING FLOORS TO MEET REQUIREMENTS IF NECESSARY.
 - H. CONTRACTOR TO VERIFY SCHEDULED FLOOR TRANSITION STRIP PROFILES & SIZE AGAINST FLOORING MATERIALS (BOTH NEW & EXISTING) FOR ADA COMPLIANCE PRIOR TO INSTALLATION, INCLUDING ANY NEEDED FOR RAMPED LOCATIONS.
 - 1. PROVIDE FLOOR PLAN NOTING EACH TRANSITION STRIP AS INDICATED IN THE MATERIALS SCHEDULE & LOCATION OF FLOOR TRANSITION STRIPS FOR ARCHITECT'S REVIEW.
 - 2. WHERE FLOOR MATERIAL TRANSITIONS HAVE SAME MATERIAL THICKNESS, DO NOT INSTALL TRANSITION STRIP BETWEEN MATERIALS UNLESS OTHERWISE NOTED. INSTALL FLOORING WITH TIGHT JOINTS AND NO VISIBLE GAPS.
 - 3. FOR ALL TRANSITION STRIPS (TS-#), TRANSITIONS OF FLOORING MATERIALS TO OCCUR UNDER DOOR IN THE CLOSED POSITION UNLESS OTHERWISE INDICATED IN THE DRAWINGS.
 - 4. CONSULT ARCHITECT WITH QUESTIONS ON FLOOR TRANSITIONS & TRANSITION STRIPS PRIOR TO ORDERING MATERIAL.
 - I. CONTINUE FLOOR FINISHES & PATTERNS BENEATH EQUIPMENT, MOVEABLE ITEMS & OPEN (KNEE SPACE) MILLWORK.
 - J. FLOOR DRAIN GRATES TO BE SET AT 90° TO FLOORING PATTERN. IF FLOORING DOES NOT HAVE A PATTERN TO ALIGN TO, GRATE TO BE SET AT 90° TO ADJACENT WALL(S).
- WALLS:**
- K. ALL WALL FINISHES SHOWN ON FINISH PLAN ARE FOR CLARIFICATION ONLY; COORDINATE FINISHES WITH THE ROOM FINISH SCHEDULE. WHERE DISCREPANCIES BETWEEN THE ROOM FINISH SCHEDULE, FINISH PLAN, DETAILS OR ELEVATIONS OCCUR, CONTACT ARCHITECT'S OFFICE IMMEDIATELY FOR CLARIFICATION PRIOR TO PROCEEDING.
 - L. CONTRACTOR SHALL PROVIDE ALL BLOCKING AS REQUIRED FOR WALL MOUNTED ACCESSORIES & SPECIALTY EQUIPMENT, INCLUDING BUT NOT LIMITED TO ALL TOILET & BATH ACCESSORIES, MARKER BOARDS, TACK BOARDS, AUDIO VISUAL & MEP INDICATED EQUIPMENT. CONTRACTOR TO PROVIDE BLOCKING FOR WALL MOUNTED ITEMS INDICATED BY OTHERS.
 - M. WHERE PRODUCTS OR EQUIPMENT PLACEMENT SPANS FROM TILE TO DRYWALL OR OTHER MATERIAL, PROVIDE WHITE UHMW PLASTIC FILLER OF THE SAME THICKNESS AS TILE BEHIND PRODUCT, AT DRYWALL OR OTHER MATERIAL. THIS MAY OCCUR AT (BUT IS NOT LIMITED TO) TOILET PARTITIONS, MIRRORS OR OTHER TOILET & BATH ACCESSORIES.
- CEILING:**
- N. SEE REFLECTED CEILING PLAN(S) FOR ALL ROLLER SHADE (RS-#) LOCATIONS AND DETAILS.
- MECHANICAL & ELECTRICAL & OWNER PROVIDED COORDINATION:**
- O. SEE ELECTRICAL DRAWINGS FOR ALL FLOOR RECEPTACLE LOCATIONS. COORDINATE MILLWORK OPENINGS WITH ELECTRICAL LOCATIONS WHERE OCCURRING.
 - P. ALL LOUVRES, VENTS, GRILLES, DUCTWORK & OTHER MISCELLANEOUS MECHANICAL & ELECTRICAL DEVICES IN EXPOSED LOCATIONS SHALL BE PAINTED TO MATCH THE SURFACE IN WHICH THEY APPEAR, UNLESS OTHERWISE NOTED.
 - Q. PAINT INTERIOR SURFACES OF DUCTS LOW VOC BLACK WHERE SURFACES ARE VISIBLE THROUGH GRILLES AND DIFFUSERS.
 - R. PAINT ALL EXPOSED FIRE SUPPRESSION (BOTH NEW AND EXISTING) SPRINKLER PIPING, PAINT TO MATCH ADJACENT SURFACE.
 - S. ALL FURNITURE SHOWN ON PLANS TO BE PROVIDED BY OWNER AND SHOWN FOR REFERENCE ONLY. CONTRACTOR TO VERIFY FURNITURE LAYOUT WITH OWNER AND OWNERS FURNITURE VENDOR. CONTRACTOR TO COORDINATE POWER & DATA CONNECTIONS AT FURNITURE WITH VENDOR & IN ACCORDANCE WITH CONSTRUCTION DOCUMENTS [SEE ELECTRICAL].

- FINISHES NOTES**
1. NOTE 1
 2. NOTE 2

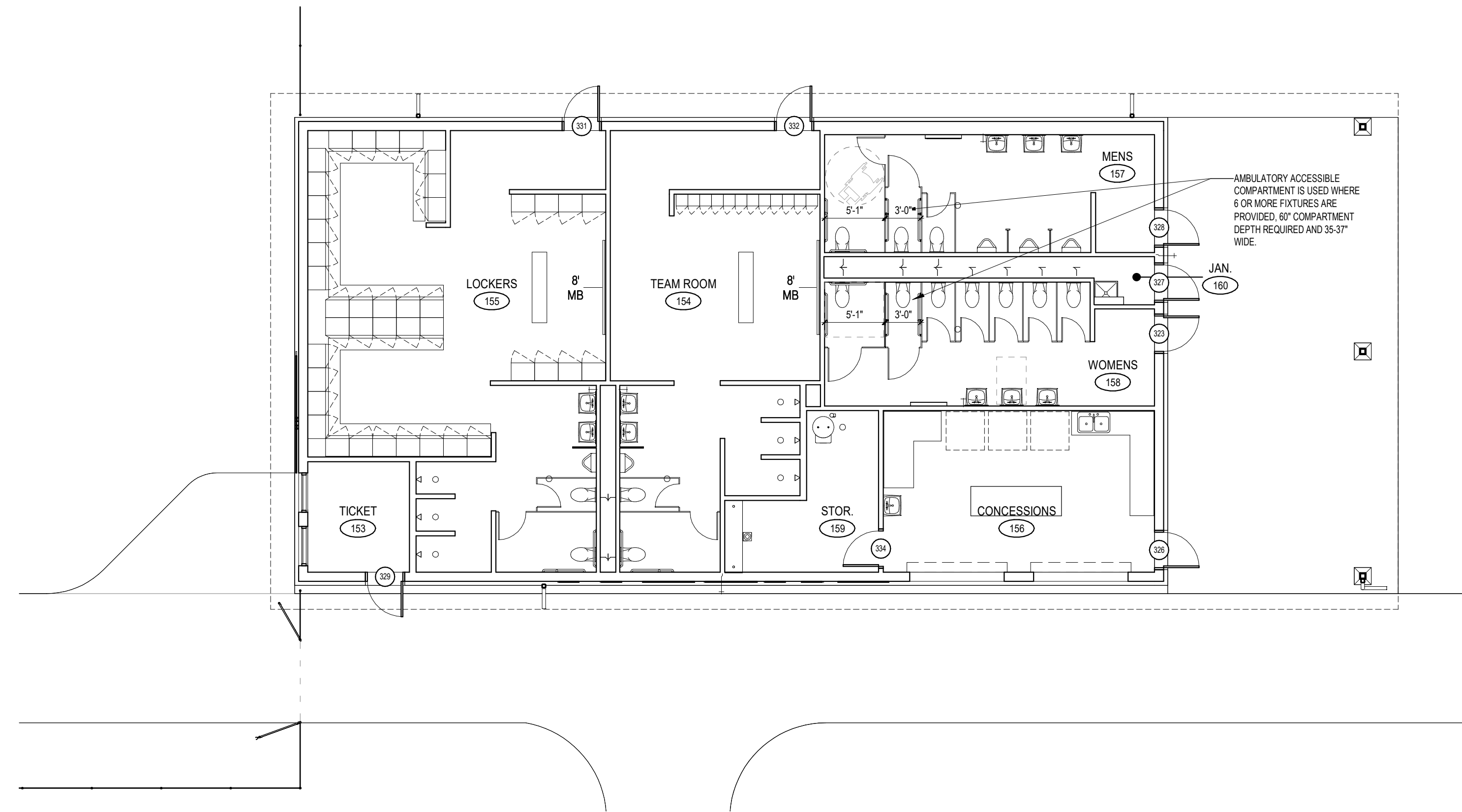

1 FIRST FLOOR FINISH PLAN
1/8" = 1'-0"

FINISH ABBREVIATIONS

ACT	ACOUSTIC CEILING TILE
AFF	ABOVE FINISHED FLOOR
ALUM	ALUMINUM
AMP	ACOUSTIC WALL PANEL
BR	BRICK
CB	CEMENTITIOUS BOARD
CG	CORNER GUARD
CMT	CERAMIC MOSAIC TILE
CMU	CONCRETE MASONRY UNIT
CMC	CONCRETE
CPT	CARPET
CT	CERAMIC TILE
ERF	EPOXY RESINOUS FLOORING
ES	EXPOSED STRUCTURE
EX	EXISTING
FRE	FIBER-REINFORCED ABRASION RESISTANT EPOXY COATING
FRP	FIBERGLASS REINFORCED PANELING
G	GROUT
GB	GYPSON BOARD
GL	GLASS / GLAZING
GMGB	GLASS MAT GYPSON BOARD
GT	GLASS TILE
HGB	HIGH-IMPACT / ABUSE RESISTANT GYPSON BOARD
L	LOCKERS
MP	METAL PANEL
MRGB	MOISTURE-RESISTANT GYPSON BOARD
NF	NO FINISH
OWP	OPERABLE WALL PARTITION
P	PAINT
PFT	PORCELAIN FLOOR TILE
PWT	PORCELAIN WALL TILE
PL	PLASTIC LAMINATE
RS/WS	ROLLER SHADE/WINDOW SHADE
RST	RUBBER SHEET FLOORING
RST	RUBBER STAIR TREAD
SC	SPECIAL COATINGS (DIV 9 SECTION HIGH PERFORMANCE SPECIAL WALL COATINGS)
SSM	SOLID SURFACE MATERIAL
RCP	REFLECTED CEILING PLAN
SLD	SEALED
ST	STAIN
TS	TRANSITION STRIP
VB	VINYL BASE
VCT	VINYL COMPOSITION TILE
VVC	VINYL WALL COVERING
WB	WOOD BASE
WD	WOOD
WPM	WATERPROOF MEMBRANE

FLOOR FINISH LEGEND:

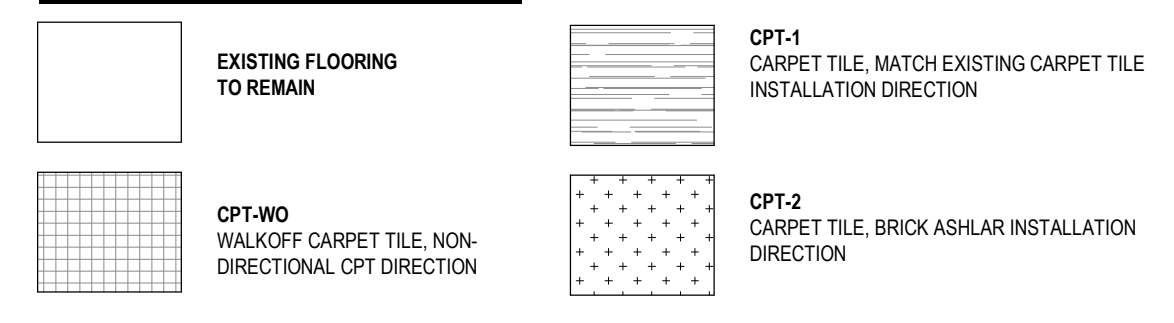

FINISHES KEYNOTES:

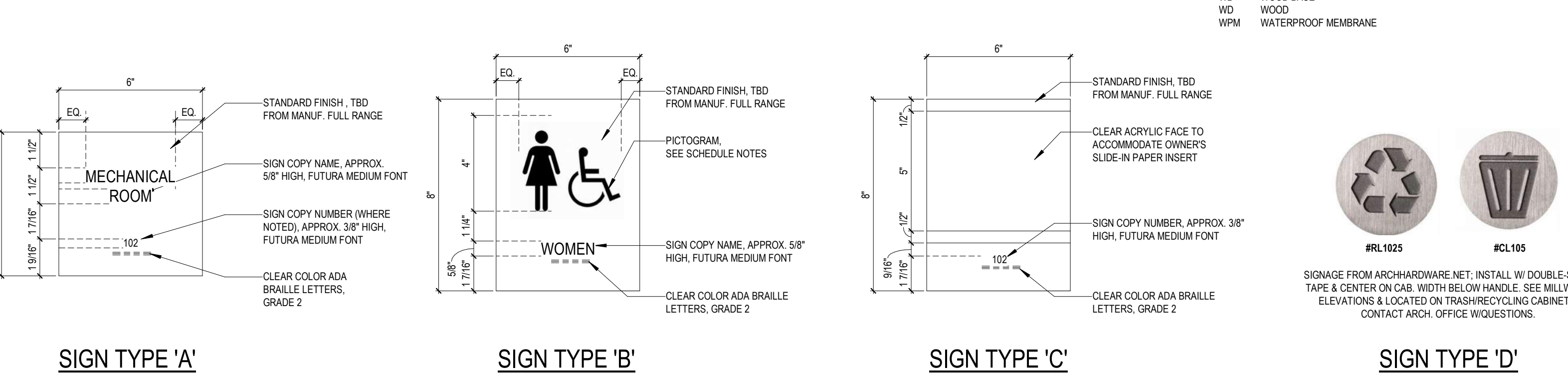
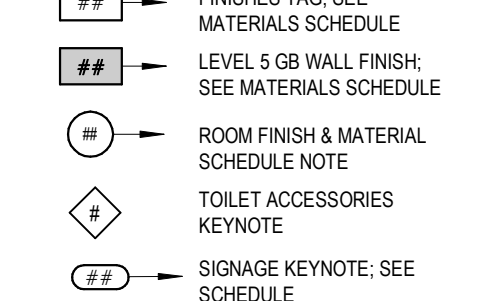

INTERIOR SIGNAGE NOTES:

1. SIGNAGE SHALL BE CONSTRUCTED AND INSTALLED IN ACCORDANCE WITH THE AMERICANS WITH DISABILITIES ACT.
2. VERIFY SIGNAGE TEXT AND NUMBERING WITH OWNER, PRIOR TO FABRICATION.
3. SIGNAGE TO BE MOUNTED 48" MIN. TO 60" MAX. A.F.F. ON THE SWING SIDE OF DOOR OR ON SIDE LIGHT/GLASS, AS APPLICABLE. SIGNAGE MOUNTED ON GLASS REQUIRED TO HAVE AN EQUALLY SIZED BACK PLATE ON THE OPPOSITE (INTERIOR) FACE OF GLASS TO CONCEAL MOUNTING ADHESIVE.
4. SIGNAGE TO BE MOUNTED WITH DOUBLE STICK TAPE, U.O.N.
5. SIGNAGE TO BE QUANTITY OF 1 TYPICAL, U.O.N.

INTERIOR PANEL SIGN SCHEDULE						
SIGN ID#	SIGN TYPE	ROOM#	SIGN TEXT	INSERT TEXT	PICTOGRAM	NOTES



SIGNAGE PICTOGRAM

MATERIALS SCHEDULE							
SECTION	TAG	MANUFACTURER	COLLECTION/STYLE	COLOR	SIZE	DISTRIBUTOR/REP.	NOTES
064023 - INTERIOR ARCHITECTURAL CASEWORK							
064023 - INTERIOR ARCHITECTURAL CASEWORK	PL-1						
093000 - TILING							
093000 - TILING							
095113 - ACOUSTICAL PANEL CEILING							
095113 - ACOUSTICAL PANEL CEILING	ACT-1						
096513 - RESILIENT BASE & ACCESSORIES							
096513 - RESILIENT BASE & ACCESSORIES	VB-1						
096519 - RESILIENT TILE FLOORING							
096519 - RESILIENT TILE FLOORING	LVT-1						
096813 - TILE CARPETING							
096813 - TILE CARPETING	CPT-1						
099120 - PAINT							
099120 - PAINT	P-1			SEE SPECIFICATIONS			
099600 - HIGH PERFORMANCE COATINGS							
099600 - HIGH PERFORMANCE COATINGS	SC-1						
123661.16 - SOLID SURFACE COUNTERTOPS							
123661.16 - SOLID SURFACE COUNTERTOPS	SSM-1						
123661.19 - QUARTZ AGGLOMERATE COUNTERTOPS							
123661.19 - QUARTZ AGGLOMERATE COUNTERTOPS	QSM-1						

ROOM FINISH SCHEDULE															
NO.	NAME	FLOOR			NORTH WALL		EAST WALL		SOUTH WALL		WEST WALL		CEILING		NOTES
		MATL	FINISH	BASE	MATL	FINISH	MATL	FINISH	MATL	FINISH	MATL	FINISH	MATL	FINISH	
105	TRAINERS ROOM/STORAGE														
106	CONCESSIONS														
107	MENS														
108	WOMENS														
109	TEAM ROOM														
110	COACHES														
111	FIELD STORAGE														
112	LOCKERS														
113	LOCKERS														
114	MENS														
115	WOMENS														
116	LOCKERS														
117	EQUIPMENT & TRAINING STORAGE														
118	STOR.														
128	FIELD STORAGE														
133	EQUIPMENT & TRAINING STORAGE														
138	STOR.														
139	LOCKERS														
146	Room														
153	TICKET														
154	TEAM ROOM														
155	LOCKERS														
156	CONCESSIONS														
157	MENS														
158	WOMENS														
159	STOR.														
160	JAN.														
C390	TRAINERS ROOM/STORAGE														
C391	CONCESSIONS														
C392	MENS														
C393	WOMENS														
C394	TEAM ROOM														
C395	TEAM ROOM														
C396	COACHES														



NOT FOR CONSTRUCTION

REVISION SCHEDULE
MARK DESCRIPTION REVISION DATE

ROOF TAG
ROOF _

NEW ROOF SUMMARY	
ROOF _	
SF	
1.	METAL DECK
2.	VAPOR BARRIER
3.	ONE LAYER 2" POLYISOCYANURATE INSUL., MECHANICALLY ATTACHED.
4.	TAPERED CRICKETS ADHERED IN INSUL. ADHESIVE.
5.	ONE LAYER 2" POLYISOCYANURATE INSUL., ADHERED IN RIBBONS OF INSUL. ADHESIVE.
6.	1/4" DENS DECK PRIME, ADHERED IN RIBBONS OF INSUL. ADHESIVE.
7.	0.060 MIL EPDM, FULLY-ADHERED
ROOF _	
SF	
1.	TEXT
2.	TEXT
3.	TEXT

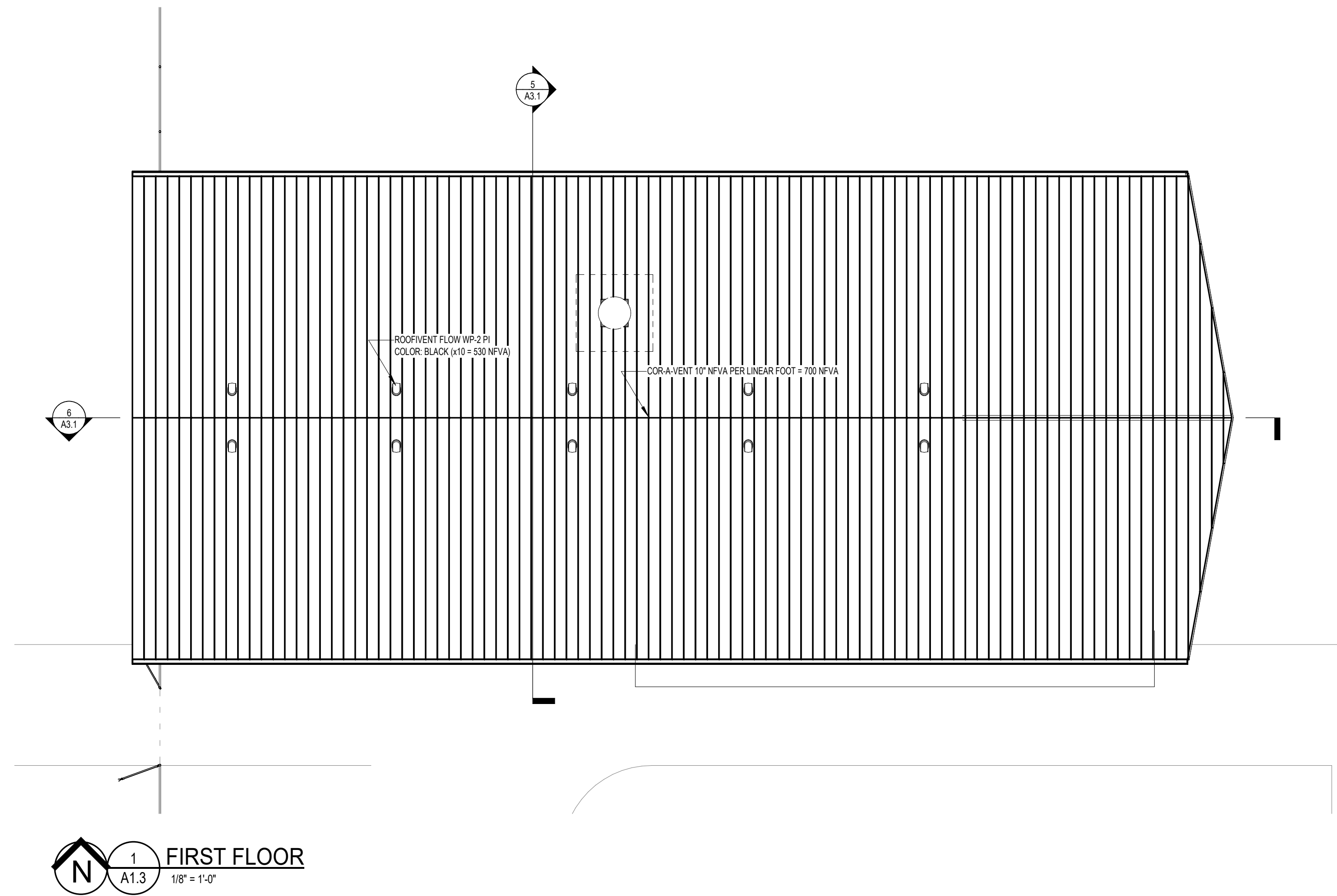

ROOF PLAN LEGEND:

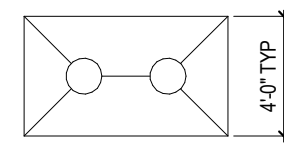

ROOF DRAIN AND OVERFLOW DRAIN W/
BOARD INSULATION SUMP



MEMBRANE ROOFING W/ TAPERED INSULATION OVER BASE INSULATION
- 1/4" FT MIN POSITIVE SLOPE

GENERAL NOTES:

WORK SHOWN ON DRAWINGS IS TO INDICATE IN A GENERAL MANNER THE EXTENT OF WORK AND IS NOT INTENDED TO BE ALL-INCLUSIVE. REFER TO THE PROJECT MANUAL FOR ADDITIONAL REQUIREMENTS. VERIFY ALL CONDITIONS AT THE BUILDING SITE.

PROVIDE 8" MIN CLEARANCE AT ALL CURBS, PARAPETS, AND FLASHINGS ABOVE THE ROOF TO WALL TRANSITION UNO.

SEE STRICT FOR FRAMING REQUIREMENTS AROUND ROOF PENETRATIONS AND EQUIPMENT.

COORDINATE SIZE AND LOCATIONS OF ALL ROOF PENETRATIONS AND EQUIPMENT. SEE MECH AND ELEC DRAWINGS FOR ANY EQUIPMENT NOT SHOWN. FLASH AND SEAL ALL EQUIPMENT AND TRANSITIONS PER ROOFING MFR'S RECOMMENDATIONS.

PROVIDE CRICKETS AT ALL ROOF PENETRATIONS.

SECURE ALL BELOW DECK PIPE CONNECTIONS AFTER NEW ROOF INSTALLATION.

SEE SPECIFICATIONS FOR INFORMATION ON ROOF SYSTEM.



NOT FOR
CONSTRUCTION

REVISIONSCHEDULE	MARK	DESCRIPTION	REV. DATE

02/05/2026

A1.3

25157

EXTERIOR MATERIALS SCHEDULE						
SECTION	TAG	MANUFACTURER	COLLECTION/STYLE	COLOR	FINISH	NOTES
042000	FB-1	ENDICOTT	COPPERTONE			
074000	MR-1	BERRIDGE	T-PANEL	CHARCOAL GREY		
074213.13	MP-1	BERRIDGE	L-PANEL	CHARCOAL GREY		
074213.13	MP-2	BERRIDGE	L-PANEL	CHARCOAL GREY		
076200	MF-1			MATCH BERRIDGE CHARCOAL GREY		

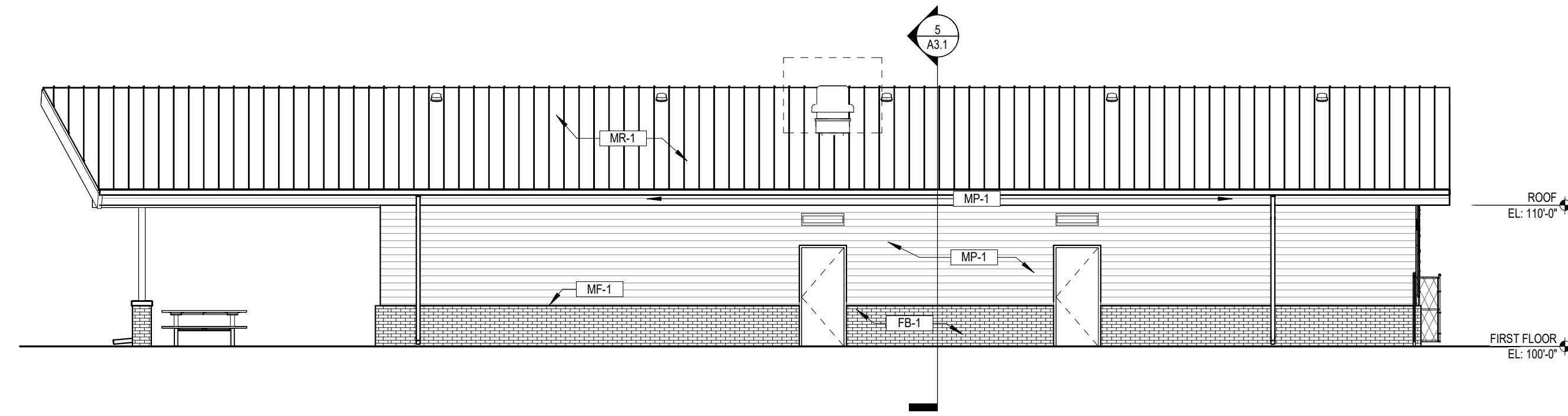

1 NORTH ELEVATION
A3.1 1/8" = 1'-0"

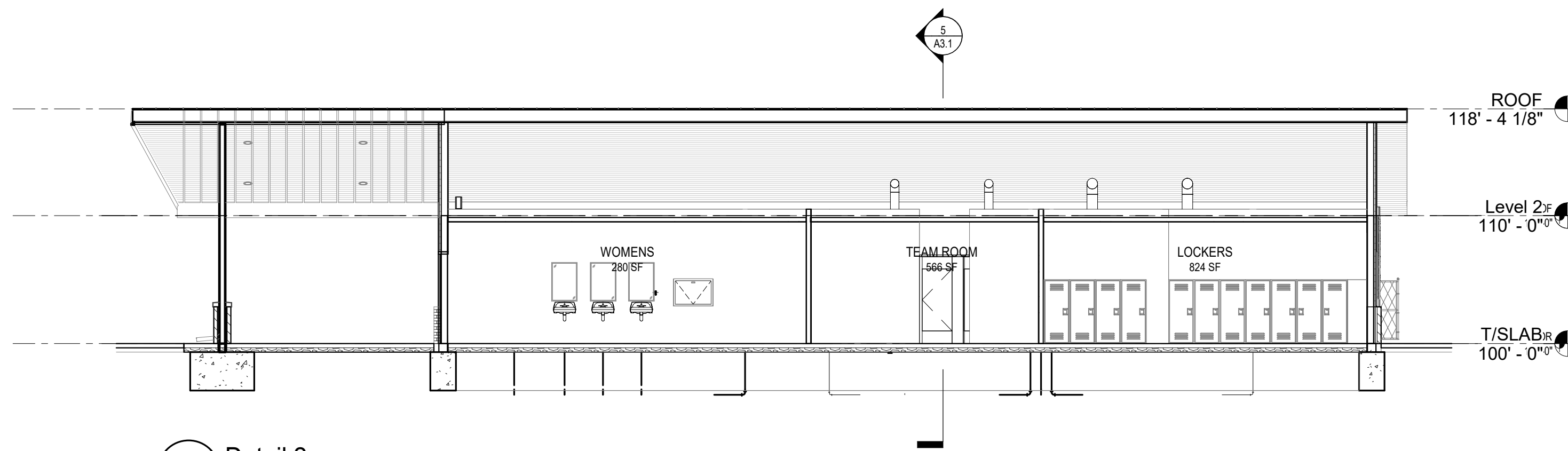

6 Detail 2
A3.1 1/8" = 1'-0"

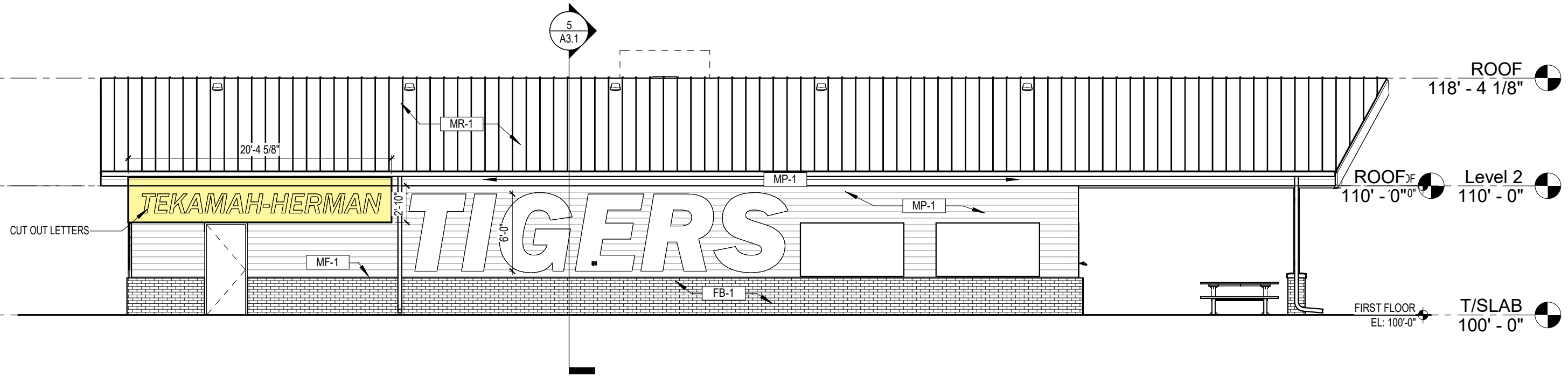

2 SOUTH ELEVATION
A3.1 1/8" = 1'-0"

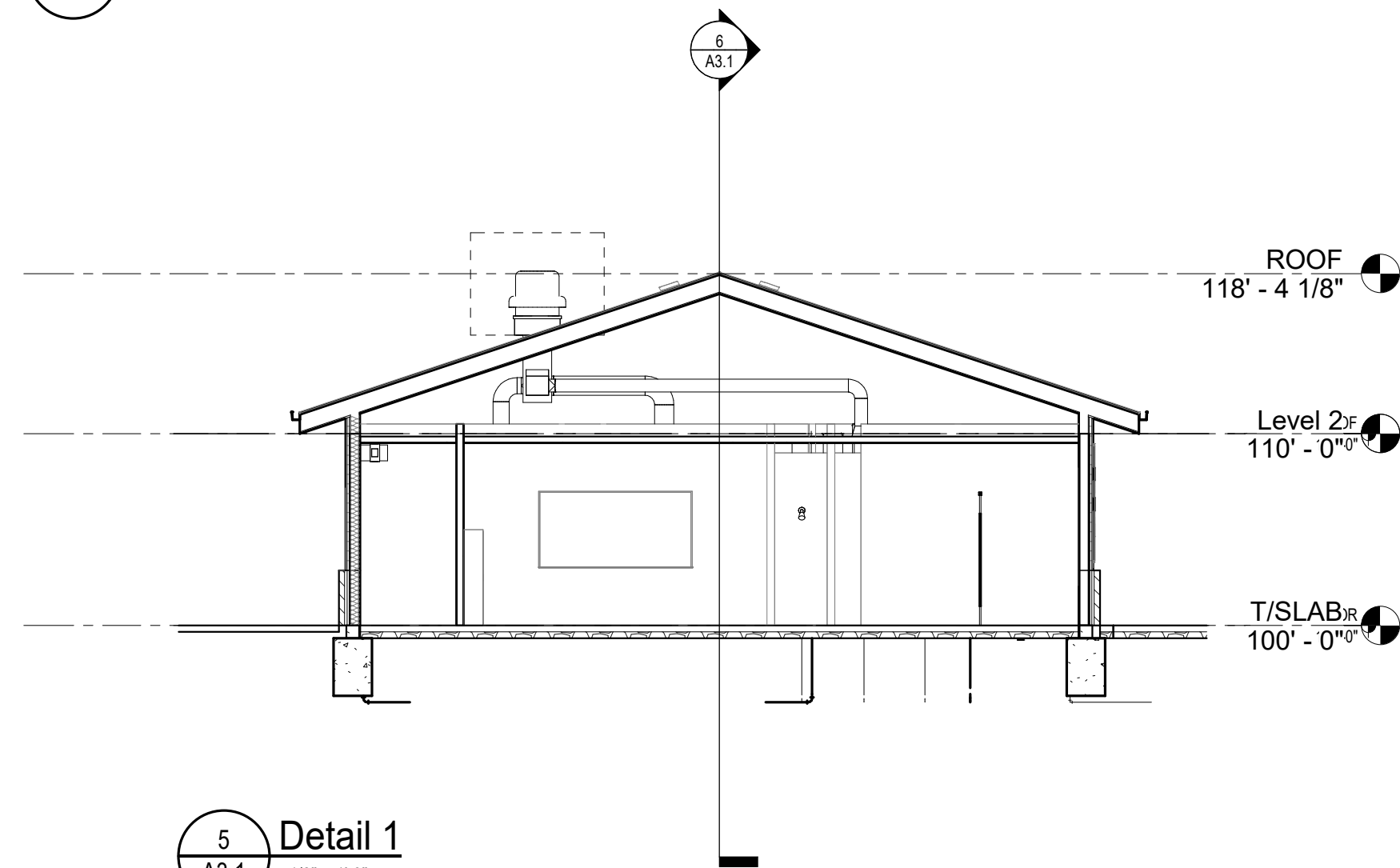

5 Detail 1
A3.1 1/8" = 1'-0"

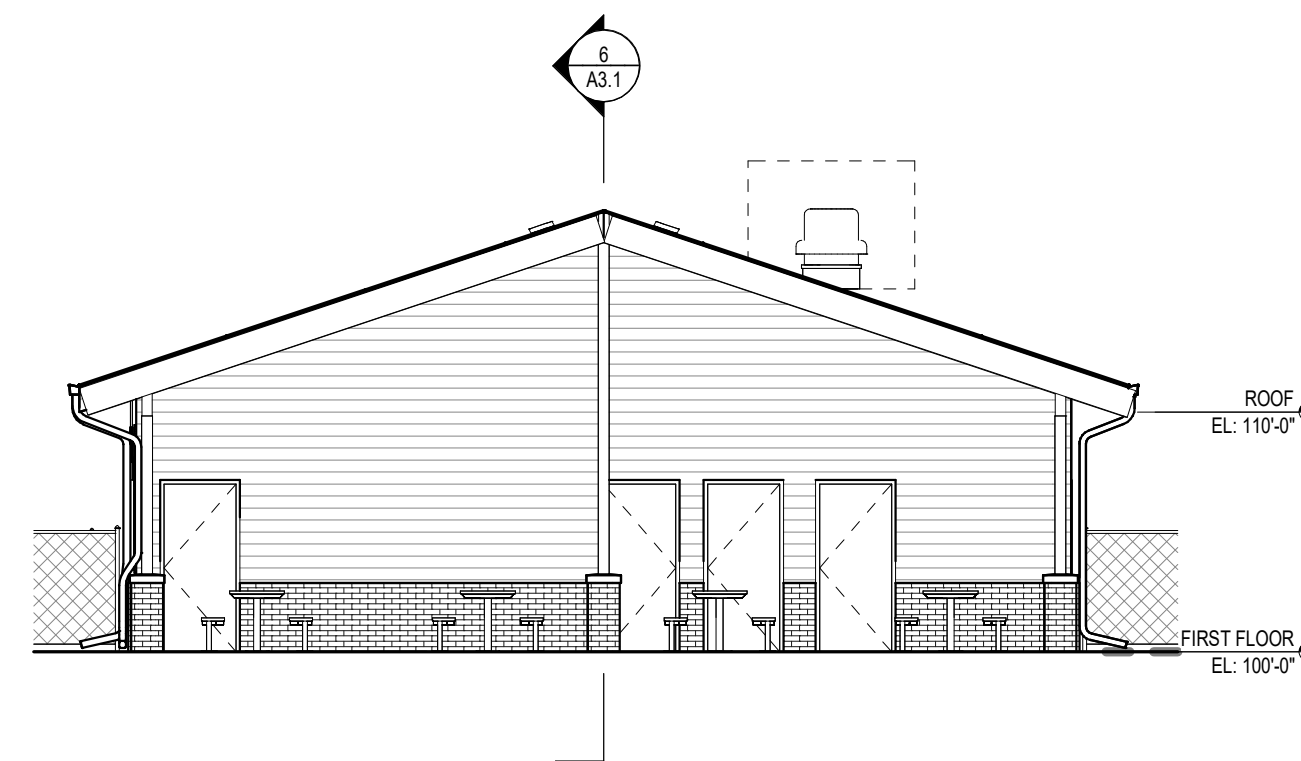

3 EAST ELEVATION
A3.1 1/8" = 1'-0"

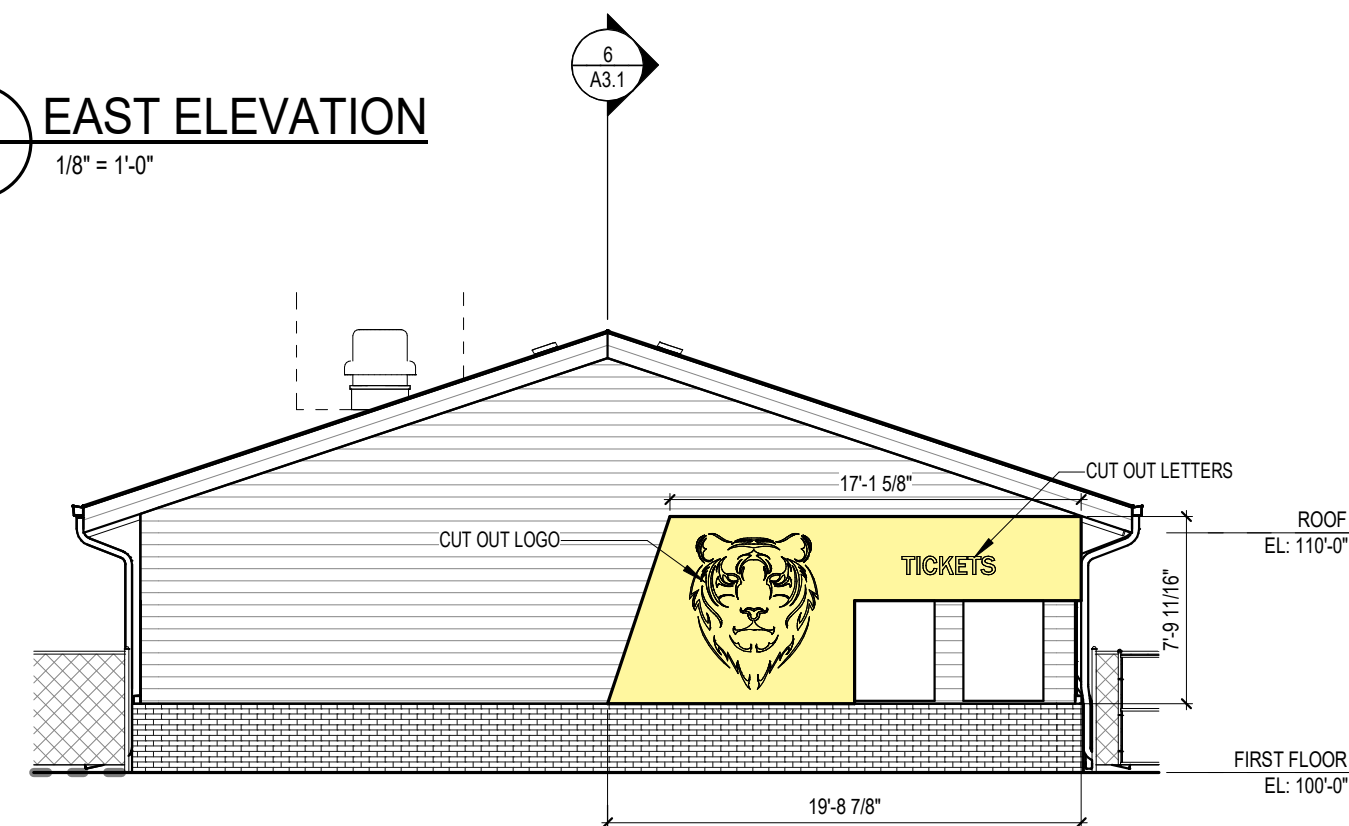

4 WEST ELEVATION
A3.1 1/8" = 1'-0"



NOT FOR
CONSTRUCTION

REVISION SCHEDULE
MARK DESCRIPTION REVISION DATE

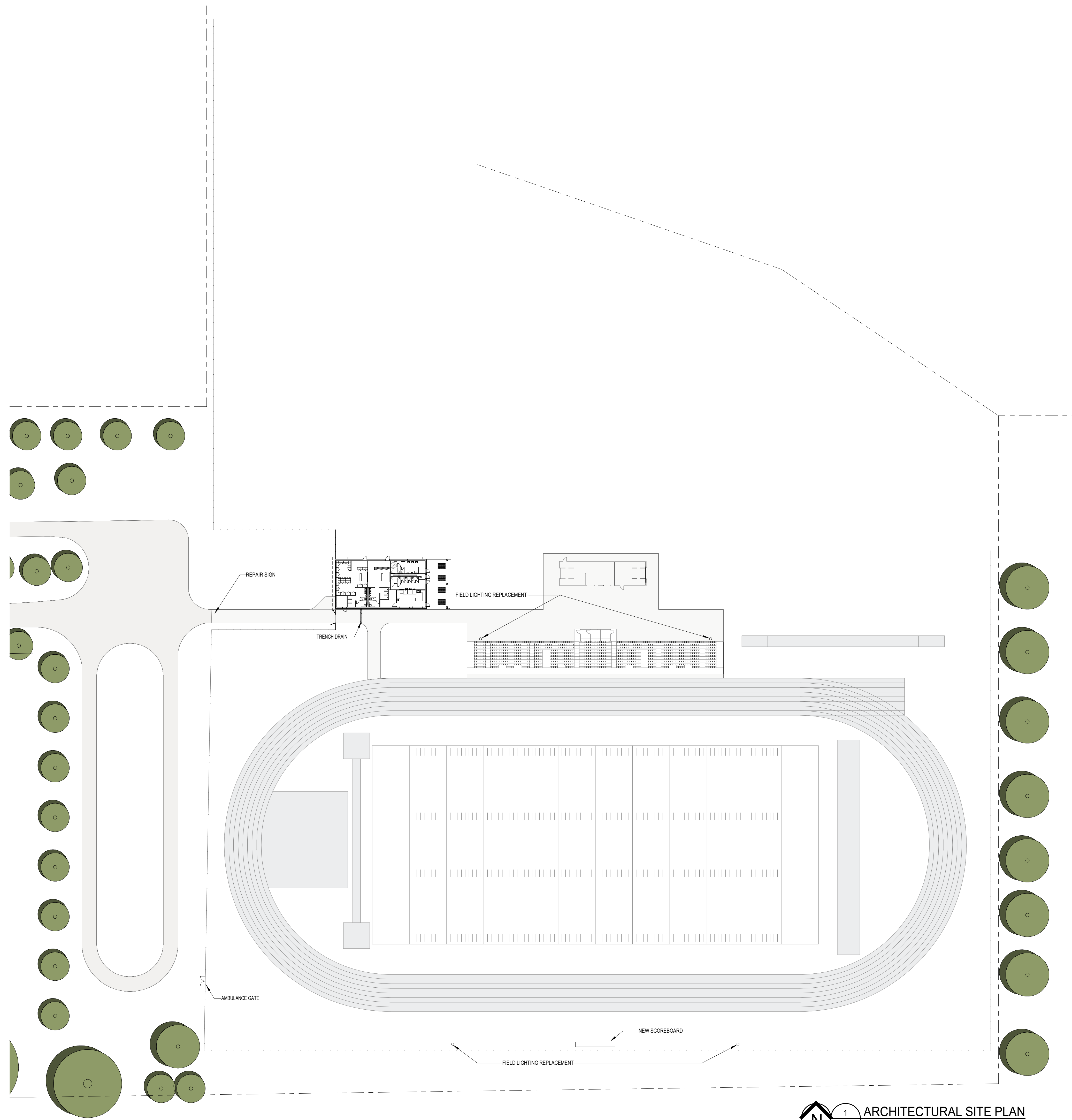

REVISION	DATE	DESCRIPTION

FLOOR PLAN & ARCHITECTURAL SITE PLAN
TEKAMAH-HERMAN SCHOOLS
TRACK & FIELD

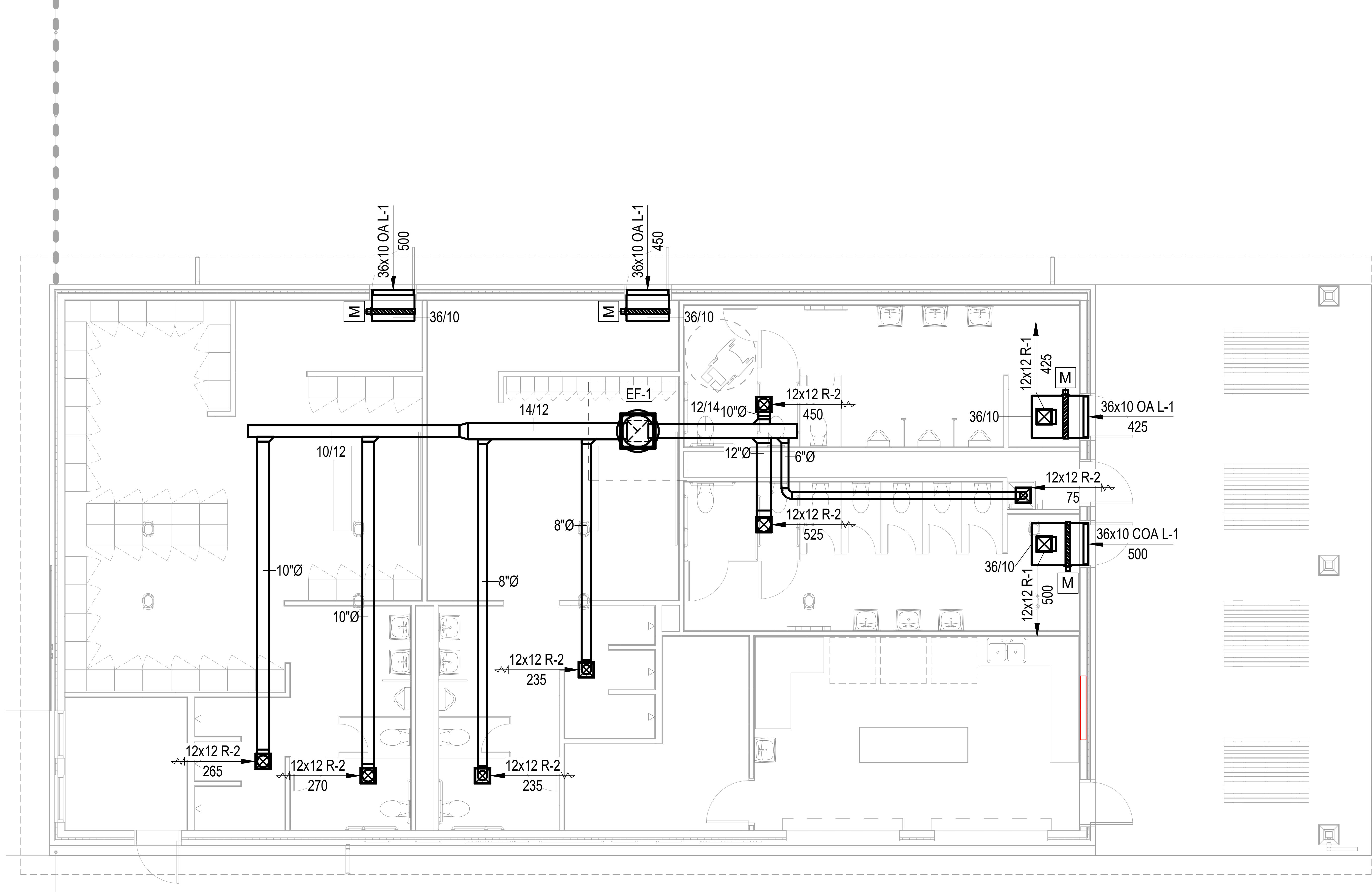

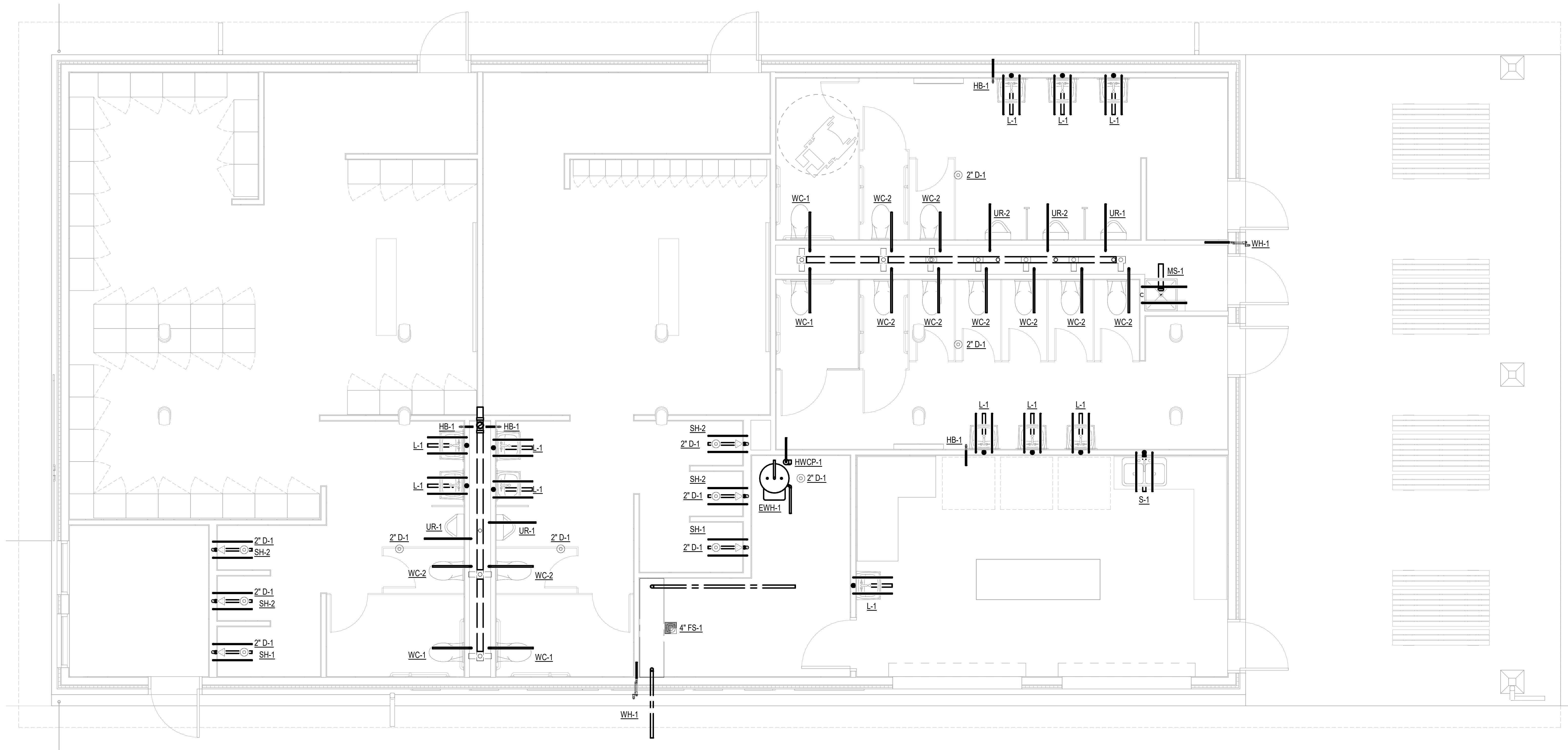



OPTION 1 - NE PERSPECTIVE



OPTION 2 - NE PERSPECTIVE



OPTION 1&2 - NW PERSPECTIVE



OPTION 3 - NE PERSPECTIVE



OPTION 4 - NE PERSPECTIVE



OPTION 3&4 - NW PERSPECTIVE