

Minden Public Schools
Board of Education
Board of Education Regular Meeting
C.L. Jones Middle School
520 West Third
Minden, NE 68959
Monday, September 12, 2016 7:30 PM

1. Roll Call
 - 1.a. Consider, Discuss, and Take Action on Excusing the Absence of Board Member Raun
2. Budget Hearing
 - 2.a. Open Hearing on Proposed 2016-2017 Budget
 - 2.b. Hearing on Proposed 2016-17 Budget
 - 2.c. Close Hearing on Proposed 2016-17 Budget
3. Proposed Tax Request Hearing
 - 3.a. Open Hearing on Proposed 2016-17 Tax Request
 - 3.b. Hearing on Proposed 2016-17 Tax Request
 - 3.c. Close Hearing on Proposed 2016-17 Tax Request
4. Minutes
5. Public Comment
6. Financial Reports – Action Items
 - 6.a. Consider Financial Reports
7. Old Business – Action Items
 - 7.a. Consider Bills – General Fund
8. Discussion Only
 - 8.a. Report from Superintendent
 - 8.b. Reports from Administrators
 - 8.c. Facilities Update
9. New Business
 - 9.a. Consider, Discuss, and Take Action on the 2016/2017 Budget
 - 9.b. Consider, Discuss, and Take Action on the Final Tax Request and Read Resolution
 - 9.c. Consider, Discuss, and Take Action on Amendments to Policy 5104 Drug & Substance Use & Prevention - Final Reading
 - 9.d. Consider, Discuss, and Take Action on Tech Club Trip -- added 9/9/16
 - 9.e. Consider, Discuss, and Take Action Regarding Ratification of Change Orders and Construction Change Directives for the New Minden High School Building Project Approved Pursuant to the Minden Public Schools -- Board of Education Protocol Re: 2014 Bond Issue Projects - Construction Change Orders and Construction Change Directives -- added 9/9/2016
10. Additional Information
11. Adjournment

NOTICE OF BUDGET HEARING AND BUDGET SUMMARY

State of Nebraska
Budget Form - NBH-School District
 Statement of Publication

Minden Public Schools (50-0503) in Kearney County, Nebraska

PUBLIC NOTICE is hereby given, in compliance with the provisions of State Statute Sections 13-501 to 13-513, that the governing body will meet on the 12th day of September, 2016 at 7:30 o'clock, P.M., at C.L. Jones Middle School Media Center for the purpose of hearing support, opposition, criticism, suggestions or observations of taxpayers relating to the following proposed budget and to consider amendments relative thereto. The budget detail is available at the office of the Clerk/Secretary during regular business hours.

Ken Carpenter

Clerk/Secretary

FUNDS	Actual Disbursements & Transfers		Actual/Estimated Disbursements & Transfers		Budgeted Disbursements & Transfers		Necessary Cash Reserve (4)	Total Available Resources Before Property Taxes (5)	Fee and Delinquent Tax Allowance (6)	Total Personal and Real Property Tax Requirement (7)
	2014-2015 (1)	2015-2016 (2)	2015-2016 (2)	2016-2017 (3)						
General	\$ 9,644,298.00	\$ 10,576,866.38	\$ 12,264,686.80	\$ 1,100,000.00	\$ 4,844,981.12	\$ 86,057.55	\$ 8,605,763.23			
Depreciation	\$ -	\$ -	\$ 1,934,542.19	\$ -	\$ 1,934,542.19	\$ -	\$ -			
Employee Benefit	\$ -	\$ -	\$ 35,336.00	\$ -	\$ 35,336.00	\$ -	\$ -			
Contingency	\$ -	\$ -	\$ -	\$ -	\$ -	\$ -	\$ -			
Activities	\$ 324,609.00	\$ 289,512.17	\$ 474,179.26	\$ -	\$ 474,179.26	\$ -	\$ -			
School Nutrition	\$ 319,447.00	\$ 319,689.00	\$ 465,245.00	\$ -	\$ 465,245.00	\$ -	\$ -			
Bond	\$ 343,764.00	\$ 274,611.00	\$ 1,423,392.75	\$ 450,000.00	\$ 453,029.00	\$ 14,347.09	\$ 1,434,710.84			
Special Building	\$ 1,279,821.00	\$ 9,624,374.00	\$ 16,591,227.00	\$ -	\$ 16,311,227.00	\$ 2,828.28	\$ 282,828.28			
Qualified Capital Purpose Undertaking	\$ 35.00	\$ 5.00	\$ 10.00	\$ -	\$ 10.00	\$ -	\$ -			
Cooperative	\$ -	\$ -	\$ -	\$ -	\$ -	\$ -	\$ -			
Student Fee	\$ 7,664.00	\$ 12,394.51	\$ 12,105.72	\$ -	\$ 12,105.72	\$ -	\$ -			
TOTALS	\$ 11,919,638.00	\$ 21,097,452.06	\$ 33,200,724.72	\$ 1,550,000.00	\$ 24,530,655.29	\$ 103,232.92	\$ 10,323,302.35			

Total Personal and Real Property Tax Requirement For Bonds

\$ 1,434,710.84

Total Personal and Real Property Tax Requirement for ALL Other

\$ 8,888,591.51

Notice of Special Hearing To Set Final Tax Request

Mindon Public Schools (50-0503) in Kearney County, Nebraska

PUBLIC NOTICE is hereby given, in compliance with the provisions of State Statute Section 77-1601.02, that the governing body will meet on the 12th day of September 2016 at 7:30 o'clock P.M., at C.L. Jones Middle School Media Center for the purpose of hearing support, opposition, criticism, suggestions or observations of taxpayers relating to setting the final tax request at a different amount than the prior year tax request.

2015/16 Budget Information

2016/17 Budget Information

Fund	2015-2016 Property Tax Request	2015 Tax Rate	Property Tax Rate (2015-2016 Request Divided By 2016 Valuation)	2016-2017 Proposed Property Tax Request	Proposed 2016 Tax Rate
General Fund	7,772,655.88	0.559274	0.549285	8,605,763.23	0.608160
Bond Fund(s) K - 12	1,060,606.05	0.076315	0.074952	1,434,710.84	0.101389
Bond Fund(s) K - 8			0.000000		0.000000
Bond Fund(s) 9 - 12			0.000000		0.000000
Bond Fund			0.000000		0.000000
Special Building Fund	1,515,151.50	0.109021	0.107074	282,828.28	0.019987
Qualified Capital Purpose Undertaking Fund K - 12			0.000000	-	0.000000
Qualified Capital Purpose Undertaking Fund K - 8			0.000000		0.000000
Qualified Capital Purpose Undertaking Fund 9 - 12			0.000000		0.000000

**MINDEN PUBLIC SCHOOLS
BOARD OF EDUCATION
August 24, 2016**

The agenda for the August 24, 2016 meeting was posted at the United States Post Office in Minden, Minden Exchange Bank, First Bank and Trust Company, Kearney County Courthouse, and the Minden city office. Agendas were mailed to the United States Post Office in Upland and Heartwell. The agenda was posted in the superintendent's office and published in the local paper.

The board meeting began at 1:04 pm with all board members present.

Motion by Grams and second by Rhynalds to approve the 2015/2016 year end bills. Roll call: Carpenter, aye; Glanzer, aye; Grams, aye; Jacobsen, aye; Raun, aye; Rhynalds, aye. Motion carried.

Motion by Glanzer and second by Raun to rescind the bond issuance action from the August 8, 2016, meeting due to incorrect wording. Roll call: Carpenter, aye; Glanzer, aye; Grams, aye; Jacobsen, aye; Raun, aye; Rhynalds, aye. Motion carried.

Motion by Raun and second by Glanzer to authorize the issuance of NOT TO EXCEED \$9,050,000 of General Obligation School Building Bonds, Series 2016, for the purpose of (a) paying a portion of the costs of purchasing land, site preparation, constructing a new high school building, constructing additions and improvements to the existing middle school and elementary school buildings, and providing the necessary furniture, equipment, and apparatus for such school buildings, and (b) paying the costs of issuing the Bonds. Roll call: Carpenter, aye; Glanzer, aye; Grams, aye; Jacobsen, aye; Raun, aye; Rhynalds, aye. Motion carried.

Motion by Glanzer and second by Carpenter to approve the first reading of the amendments to Policy 5104 Drug and Substance Use and Prevention. Roll call: Carpenter, aye; Glanzer, aye; Grams, aye; Jacobsen, aye; Raun, aye; Rhynalds, aye. Motion carried.

Motion by Grams and second by Jacobsen to approve construction change order #012 for the new Minden High School building project approved pursuant to the Minden Public Schools – Board of Education Protocol Re: 2014 Bond Issue Projects – Construction Change Orders and Construction Change Directives, pending approval from DLR. Roll call: Carpenter, aye; Glanzer, aye; Grams, aye; Jacobsen, aye; Raun, aye; Rhynalds, aye. Motion carried.

At 1:45 pm, a motion was made by Carpenter and second by Glanzer to adjourn the meeting. Roll call: Carpenter, aye; Glanzer, aye; Grams, aye; Jacobsen, aye; Raun, aye; Rhynalds, aye. Motion carried.

Secretary, Board of Education

**MINDEN PUBLIC SCHOOLS
BOARD OF EDUCATION
August 8, 2016**

The agenda for the August 8, 2016 meeting was posted at the United States Post Office in Minden, Minden Exchange Bank, First Bank and Trust Company, Kearney County Courthouse, and the Minden city office. Agendas were mailed to the United States Post Office in Upland and Heartwell. The agenda was posted in the superintendent's office and published in the local paper.

The board meeting began at 7:31 pm with all board members present.

Motion by Rhynalds and second by Jacobsen to approve the minutes from the meeting held July 11. Roll call: Carpenter, aye; Glanzer, aye; Grams, aye; Jacobsen, aye; Raun, aye; Rhynalds, aye. Motion carried.

Motion by Glanzer and second by Carpenter to approve the financial reports. Roll call: Carpenter, aye; Glanzer, aye; Grams, aye; Jacobsen, aye; Raun, aye; Rhynalds, aye. Motion carried.

Motion by Grams and second by Raun to approve the claims against the General Fund. Roll call: Carpenter, aye; Glanzer, aye; Grams, aye; Jacobsen, aye; Raun, aye; Rhynalds, aye. Motion carried.

Motion by Grams and second by Glanzer to approve the final reading of the amendments to Policy 3090 Sale & Disposal of School Property, Policy 3130 Purchasing Policies, Policy 3570 ESSA, Policy 5006 Option Enrollment, Policy 5203 Academic Progress, Policy 5418 Homeless Students, Policy 6020 The Program of Instruction, Policy 6212 Assessments-Academic Content Standards, Policy 6284 Initiations, Hazing, Secret Clubs & Outside Organizations, Policy 6286 Return to Learn from Cancer, Policy 6410 Title I Parental & Family Involvement, Policy 6800 Internet Safety & Acceptable Use, Policy 6920 Student Self Management of Asthma, Anaphylaxis, and/or Diabetes, Policy 8270 Conflict of Interest, and Policy 9341 Voting. Roll call: Carpenter, aye; Glanzer, aye; Grams, aye; Jacobsen, aye; Raun, aye; Rhynalds, aye. Motion carried.

Motion by Glanzer and second by Rhynalds to approve the adoption of Policy 4026 Prohibition on Aiding & Abetting Sexual Abuse, Policy 4027 Workplace Privacy, and Policy 5421 Student Privacy Protection. Roll call: Carpenter, aye; Glanzer, aye; Grams, aye; Jacobsen, aye; Raun, aye; Rhynalds, aye. Motion carried.

Motion by Glanzer and second by Carpenter to approve contract of Taylor Dreher as 5th Grade Teacher for the 2016-17 school year, pending background check. Roll call: Carpenter, aye; Glanzer, aye; Grams, aye; Jacobsen, aye; Raun, aye; Rhynalds, aye. Motion carried.

Motion by Raun and second by Glanzer to approve the group life insurance change through National Insurance Services from Guardian Life Insurance to Madison National Life Insurance.

Roll call: Carpenter, aye; Glanzer, aye; Grams, aye; Jacobsen, aye; Raun, aye; Rhynalds, aye. Motion carried.

Motion by Rhynalds and second by Jacobsen to approve the addition of EHA (Educators Health Alliance) subgroup for qualified 9-month employees. Roll call: Carpenter, aye; Glanzer, aye; Grams, aye; Jacobsen, aye; Raun, aye; Rhynalds, aye. Motion carried.

Motion by Glanzer and second by Grams to approve construction change order #010 for the new Minden High School building project approved pursuant to the Minden Public Schools – Board of Education Protocol Re: 2014 Bond Issue Projects – Construction Change Orders and Construction Change Directives. Roll call: Carpenter, aye; Glanzer, aye; Grams, aye; Jacobsen, aye; Raun, aye; Rhynalds, aye. Motion carried.

Motion by Raun and second by Jacobsen to authorize the issuance, sale, and delivery of General Obligation School Bonds in an aggregate principal amount not to exceed \$9,000,000; prescribing the form of the bonds; fixing in part and providing for the fixing in part of the terms of the bonds; providing for the levy and collection of taxes to pay the principal of and interest on the bonds; and related matters. Roll call: Carpenter, aye; Glanzer, aye; Grams, aye; Jacobsen, aye; Raun, aye; Rhynalds, aye. Motion carried.

At 8:00 pm, a motion was made by Carpenter and second by Glanzer to adjourn the meeting. Roll call: Carpenter, aye; Glanzer, aye; Grams, aye; Jacobsen, aye; Raun, aye; Rhynalds, aye. Motion carried.

Secretary, Board of Education

MINDEN PUBLIC SCHOOLS
TREASURER'S REPORT
August 31, 2016

SCHOOL BALANCE - July 31, 2016		\$85,309.02
Current Months Receipts		\$136,944.36
Transfers from Investments		\$1,300,000.00
Total Beginning Balance and Receipts		\$1,522,253.38
Less: Disbursements		\$1,416,042.37
Transfer to Investments		\$0.00
Total Disbursements		\$1,416,042.37
SCHOOL BALANCE - August 31, 2016		\$106,211.01
BALANCE PER BANK STATEMENT - August 31, 2016		\$117,411.56
Deposits In Transit		\$0.00
LESS : Outstanding Checks		\$11,200.55
RECONCILED BANK BALANCE - August 31, 2016		\$106,211.01
(Balance - August 31, 2015 = \$60,875.01)		
GENERAL FUND INVESTMENTS		\$2,236,835.01
Money Market Minden Exchange	\$1,012,098.74	0.15% demand
Money Market First Bank	\$1,224,736.27	0.25% demand
(Balance August 31, 2015 = \$2,645,933.08)		
DEPRECIATION FUND INVESTED		\$1,924,030.45
Money Market Minden Exchange Bank	\$656,190.05	0.15% demand
Money Market First Bank	\$526,839.90	0.25% demand
NE Liquid Asset Fund - Depreciation Fund	\$741,000.00	
Checking Minden Exchange Bank	\$0.50	
(Balance August 31, 2015 = \$1,323,361.01)		
EMPLOYEE BENEFITS FUND		\$35,248.37
Money Market First Bank	\$35,248.37	0.25% demand
(Balance August 31, 2015 = \$35,160.13)		
BUILDING FUND		\$5,944,981.42
Money Market Minden Exchange Bank	\$2,245,952.23	0.15% demand
Money Market First Bank	\$57,492.55	0.25% demand
NE Liquid Asset Fund - Building Fund	\$741,000.00	
Money Market First Bank - HS Constr. Acct.	\$2,900,293.59	0.25% demand
NE Liquid Asset Fund - HS Constr. Acct.	\$241.58	
Checking Minden Exchange Bank	\$1.47	
(Balance August 31, 2015 = \$14,225,943.67)		
BOND FUND		\$452,439.77
Money Market Minden Exchange Bank	\$452,439.77	
(Balance August 31, 2015 = \$0.00)		
LUNCH FUND		\$114,948.56
Money Market First Bank	\$7,928.79	0.05% demand
Checking First Bank	\$107,019.77	
(Balance August 31, 2015 = \$105,947.45)		
FUNDS PLEDGED FOR DEPOSITS		
Minden Exchange Bank	\$5,762,050.81	Plus 250M FDIC
First Bank	\$7,460,000.00	Plus 250M FDIC

William Johnson, Treasurer

Monthly Board Report All Expenses

Account	Description	Proposed Budgeted	Disbursed	Balance Remaining	Percentage Spent
1-1100	Instructional Supplies & Services	\$347,847.48	\$28,923.63	\$318,923.85	8.32%
1-1100-110	Instructional Salaries & Benefits	\$4,604,337.74	\$364,940.23	\$4,239,397.51	7.93%
1-1125	Academic Intervention Supplies & Service	\$3,600.00	\$1,250.00	\$2,350.00	34.72%
1-1125-110	Academic Intervention Salaries & Benefits	\$120,856.08	\$10,054.66	\$110,801.42	8.32%
1-1200	SPED Supplies & Services	\$99,134.79	\$668.67	\$98,466.12	0.67%
1-1200-110	SPED Salaries & Benefits	\$1,071,703.58	\$71,850.67	\$999,852.91	6.70%
1-1290	Preschool Supplies & Services	\$19,555.00	\$767.04	\$18,787.96	3.92%
1-1290-110	Preschool Salaries & Benefits	\$6,187.99	\$67.82	\$6,120.17	1.10%
1-1310	Gifted Supplies & Services	\$1,900.00	\$0.00	\$1,900.00	0.00%
1-1310-110	Gifted Salaries & Benefits	\$49,587.86	\$4,122.28	\$45,465.58	8.31%
1-2120	Guidance Supplies & Services	\$3,500.00	\$21.95	\$3,478.05	0.63%
1-2120-110	Guidance Salaries & Benefits	\$270,087.54	\$22,387.54	\$247,700.00	8.29%
1-2130	Health Services	\$41,089.96	\$4,261.33	\$36,828.63	10.37%
1-2150	Safety & Security	\$6,000.00	\$0.00	\$6,000.00	0.00%
1-2190	Activities Supplies & Services	\$30,000.00	\$7,939.30	\$22,060.70	26.46%
1-2190-110	Activities Salaries & Benefits	\$182,148.37	\$10,441.46	\$171,706.91	5.73%
1-2210	ESU Grant	\$587.64	\$0.00	\$587.64	0.00%
1-2212	Staff Training and Curriculum Development	\$5,000.00	\$468.75	\$4,531.25	9.38%
1-2215	Assessment Coordinator Supplies & Service	\$850.00	\$25.00	\$825.00	2.94%
1-2215-110	Assessment Coordinator Salary & Benefits	\$40,223.69	\$3,351.56	\$36,872.13	8.33%
1-2222	Media Center Supplies & Services	\$26,242.25	\$6,333.17	\$19,909.08	24.13%
1-2222-110	Media Center Salaries & Benefits	\$241,137.86	\$18,693.04	\$222,444.82	7.75%
1-2310	Board of Education	\$43,845.63	\$2,244.93	\$41,600.70	5.12%
1-2320	Executive Administration Supplies & Services	\$10,350.00	\$410.00	\$9,940.00	3.96%
1-2320-110	Executive Administration Salaries & Benefits	\$240,297.20	\$20,160.91	\$220,136.29	8.39%
1-2330	District Legal Services	\$20,000.00	\$114.00	\$19,886.00	0.57%
1-2410	Principals Supplies & Services	\$9,025.00	\$85.00	\$8,940.00	0.94%
1-2410-110	Principals Salary & Benefits	\$541,729.96	\$46,864.54	\$494,865.42	8.65%
1-2500	Postage & Telephone	\$15,000.00	\$83.31	\$14,916.69	0.56%
1-2510	Business Administration	\$117,816.08	\$8,170.86	\$109,645.22	6.94%
1-2520	Non-Pupil Vehicle Fuel & Maintenance	\$10,500.00	\$137.56	\$10,362.44	1.31%
1-2610	Custodial Supplies & Services	\$30,000.00	\$1,074.64	\$28,925.36	3.58%
1-2610-110	Custodial Salaries & Benefits	\$258,982.51	\$21,080.59	\$237,901.92	8.14%
1-2615	Utilities	\$355,550.00	\$26,814.87	\$328,735.13	7.54%
1-2620	Maintenance Supplies & Services	\$366,000.01	\$8,601.64	\$357,398.37	2.35%
1-2620-110	Maintenance Salaries & Benefits	\$133,859.20	\$8,474.33	\$125,384.87	6.33%
1-2620-300	Insurance	\$104,095.99	\$104,095.99	\$0.00	100.00%
1-2750	Pupil Transportation Supplies & Services	\$109,500.00	\$8,429.54	\$101,070.46	7.70%
1-2750-110	Pupil Transportation Salaries & Benefits	\$166,317.37	\$9,813.27	\$156,504.10	5.90%
1-3135	High Ability Learners	\$7,600.00	\$0.00	\$7,600.00	0.00%
1-4200	Title I Part A	\$115,471.00	\$7,769.70	\$107,701.30	6.73%
1-4310	Title II Part A	\$23,424.00	\$5,881.71	\$17,542.29	25.11%
1-4400	Federal Funds	\$169,077.00	\$29,634.96	\$139,442.04	17.53%
1-6000	Summer School	\$9,026.14	\$0.00	\$9,026.14	0.00%
1-8000	Interfund Transfers	\$50,000.00	\$0.00	\$50,000.00	0.00%
1-9000	Payroll Reimbursed by Other Funds/Agencies	\$5,288.76	\$220.36	\$5,068.40	4.17%
Totals		\$10,084,333.68	\$866,730.81	\$9,217,602.87	8.59%

2015/16 Projections vs. Actuals for General Fund As of August 31, 2016

Income

2015/16 Budgeted Income = \$9,669,301.54				
Month	Projected Income	Actual Income	Over/(Under) Projection	Running Balance Over/(Under) Projection
September	\$1,921,290.22	\$1,907,051.53	(\$14,238.69)	(\$14,238.69)
October	\$546,315.54	\$378,593.81	(\$167,721.73)	(\$181,960.42)
November	\$214,658.49	\$179,958.95	(\$34,699.54)	(\$216,659.96)
December	\$168,245.85	\$140,764.70	(\$27,481.15)	(\$244,141.11)
January	\$1,505,510.25	\$1,663,672.96	\$158,162.71	(\$85,978.40)
February	\$804,485.89	\$714,188.82	(\$90,297.07)	(\$176,275.47)
March	\$493,134.38	\$539,359.18	\$46,224.80	(\$130,050.67)
April	\$371,301.18	\$349,261.51	(\$22,039.67)	(\$152,090.34)
May	\$2,494,679.80	\$2,356,618.39	(\$138,061.41)	(\$290,151.75)
June	\$830,593.00	\$912,897.24	\$82,304.24	(\$207,847.51)
July	\$136,337.15	\$83,990.11	(\$52,347.04)	(\$260,194.55)
August	\$182,749.79	\$137,413.87	(\$45,335.92)	(\$305,530.47)

Cash Flow

Month	Projected Cash Flow	Actual Cash Flow	Over/(Under) Projection	Running Balance Over/(Under) Projection
September	\$1,067,992.92	\$1,003,785.00	(\$64,207.92)	(\$64,207.92)
October	(\$222,535.77)	(\$360,633.85)	(\$138,098.08)	(\$202,306.00)
November	(\$598,379.68)	(\$557,002.48)	\$41,377.20	(\$160,928.80)
December	(\$594,713.88)	(\$605,764.61)	(\$11,050.73)	(\$171,979.53)
January	\$734,695.08	\$964,816.88	\$230,121.80	\$58,142.27
February	\$30,724.93	(\$12,214.38)	(\$42,939.31)	\$15,202.96
March	(\$281,608.51)	(\$187,725.59)	\$93,882.92	\$109,085.88
April	(\$399,513.99)	(\$428,790.07)	(\$29,276.08)	\$79,809.80
May	\$1,695,388.65	\$1,591,316.25	(\$104,072.40)	(\$24,262.60)
June	(\$103,222.58)	\$155,505.29	\$258,727.87	\$234,465.27
July	(\$689,466.11)	(\$648,472.07)	\$40,994.04	\$275,459.31
August	(\$789,361.06)	(\$1,278,582.44)	(\$489,221.38)	(\$213,762.07)

Expenses

2015/16 Budgeted Expenses = \$9,819,301.54				
Month	Projected Expenses	Actual Expenses	Over/(Under) Projection	Running Balance Over/(Under) Projection
September	\$853,297.30	\$903,266.53	\$49,969.23	\$49,969.23
October	\$768,851.31	\$739,227.66	(\$29,623.65)	\$20,345.58
November	\$813,038.17	\$736,961.43	(\$76,076.74)	(\$55,731.16)
December	\$762,959.73	\$746,529.31	(\$16,430.42)	(\$72,161.58)
January	\$770,815.17	\$698,856.08	(\$71,959.09)	(\$144,120.67)
February	\$773,760.96	\$726,403.20	(\$47,357.76)	(\$191,478.43)
March	\$774,742.89	\$727,084.77	(\$47,658.12)	(\$239,136.55)
April	\$770,815.17	\$778,051.58	\$7,236.41	(\$231,900.14)
May	\$799,291.15	\$765,302.14	(\$33,989.01)	(\$265,889.15)
June	\$933,815.58	\$757,391.95	(\$176,423.63)	(\$442,312.78)
July	\$825,803.26	\$732,462.18	(\$93,341.08)	(\$535,653.86)
August	\$972,110.85	\$1,415,996.31	\$443,885.46	(\$91,768.40)

General Fund Balance

Beginning Reconciled GF Balance = \$2,706,808.09			
Month	Projected GF Balance	Actual Reconciled GF Balance	Over/(Under) Projection
September	\$3,774,801.01	\$3,710,593.09	(\$64,207.92)
October	\$3,552,265.24	\$3,349,959.24	(\$202,306.00)
November	\$2,953,885.56	\$2,792,956.76	(\$160,928.80)
December	\$2,359,171.68	\$2,187,192.15	(\$171,979.53)
January	\$3,093,866.76	\$3,152,009.03	\$58,142.27
February	\$3,124,591.69	\$3,139,794.65	\$15,202.96
March	\$2,842,983.18	\$2,952,069.06	\$109,085.88
April	\$2,443,469.19	\$2,523,278.99	\$79,809.80
May	\$4,138,857.84	\$4,114,595.24	(\$24,262.60)
June	\$4,035,635.26	\$4,270,100.53	\$234,465.27
July	\$3,346,169.15	\$3,621,628.46	\$275,459.31
August	\$2,556,808.09	\$2,343,046.02	(\$213,762.07)

Lunch Fund Checks and Liabilities

Check Number	Date	Payee	Reason	Amount
EFT	8/11/2016	Sysco - EFT	Salad Bar Shield	\$ 473.73
5088	8/11/2016	Misko Sports	Lunch Room Staff Shirts	\$ 597.00
5089	8/11/2016	Roberts Dairy	Milk Products	\$ 338.86
5090	8/11/2016	Dollar General	Lunch Room Supplies	\$ 4.00
5092	8/11/2016	Cash-wa Distributing Co.	Comodities	\$ 257.97
5093	8/11/2016	Nebraska Food Distribution	Commodities	\$ 1,322.07
5094	8/11/2016	Brown & Saegner	16 3/8"x24 3/8" Pan Liners - 1000/case	\$ 206.40
5094	8/11/2016	Brown & Saegner	18"x2000' Food Wrap	\$ 45.45
5094	8/11/2016	Brown & Saegner	2 Gallon Ziploc Bags - 100/case	\$ 37.08
5094	8/11/2016	Brown & Saegner	Pot & Pan Scouring Pads - 5/box	\$ 3.40
5095	8/11/2016	Urwiller's Melon Patch	Fresh Melons	\$ 29.50
2954	9/13/2016	Blue Cross Blue Shield	Health & Dental Insurance Premiums	\$ 5,164.97
2955	9/13/2016	Minden Public Schools	EE & ER Retirement Contributions	\$ 1,488.41
2955	9/13/2016	Minden Public Schools	EE Life Insurance Premiums	\$ 24.60
2955	9/13/2016	Minden Public Schools	Employee FEBA - Medical/Dental	\$ 83.34
2955	9/13/2016	Minden Public Schools	EE Life Insurance Premiums	\$ 26.05
2956	9/13/2016	Mps Payroll	EE & ER FICA, Medicare, & Federal Income Tax	\$ 1,368.45
2957	9/13/2016	Mps Payroll NE Income Tax	EE Nebraska Income Tax Withholding	\$ 71.06
2958	9/13/2016	Principal Life Insurance Company	ER Long-Term Disability Premiums	\$ 16.45
Subtotal				\$ 11,558.79
Net Payroll - September 2016				\$ 6,081.74
Total Lunch Fund Disbursements				\$ 17,640.53

Building Fund Liabilities - New High School Construction

Check Number	Date	Payee	Reason	Amount
EFT	9/13/2016	Boyd Jones Construction Co.	CMR Fee - 59.16% Complete	\$ 23,687.58
EFT	9/13/2016	Boyd Jones Construction Co.	Construction Effort - 72.37% Complete	\$ 29,863.00
EFT	9/13/2016	Boyd Jones Construction Co.	Reimbursable Expenses - 35.17% Complete	\$ 8,340.55
EFT	9/13/2016	Boyd Jones Construction Co.	Acoustical Seiling Tiles & Panels - 1.58% Complete	\$ 2,737.79
EFT	9/13/2016	Boyd Jones Construction Co.	Concrete - 66.41% Complete	\$230,046.30
EFT	9/13/2016	Boyd Jones Construction Co.	Earthwork/Site Demo/Site Utilities/Erosion Control - 67.32% Complete	\$ 58,724.95
EFT	9/13/2016	Boyd Jones Construction Co.	Electrical - 30.12% Complete	\$ 49,834.81
EFT	9/13/2016	Boyd Jones Construction Co.	Expansion Joint Covers - 7.58% Complete	\$ 1,381.50
EFT	9/13/2016	Boyd Jones Construction Co.	Fire Sprinkler - 60.68% Complete	\$ 9,000.00
EFT	9/13/2016	Boyd Jones Construction Co.	Waterproofing/Weather Barriers/Sealants/Subdrains - 39.65% Complete	\$ 9,141.65
EFT	9/13/2016	Boyd Jones Construction Co.	Segmental Retaining Walls - 36.39% Complete	\$ 21,828.60
EFT	9/13/2016	Boyd Jones Construction Co.	Steel Fab - 98.15% Complete	\$ 7,020.00
EFT	9/13/2016	Boyd Jones Construction Co.	Steel/HC/Precast Erection - 94.64% Complete	\$ 54,000.00
EFT	9/13/2016	Boyd Jones Construction Co.	Structural Precast - 100.37% Complete	\$ 4,519.80
EFT	9/13/2016	Boyd Jones Construction Co.	Subcontractor Bond Allowance - 83.94% Complete	\$ 4,050.00
EFT	9/13/2016	Boyd Jones Construction Co.	Surveying - 98.71% Complete	\$ 3,765.71
EFT	9/13/2016	Boyd Jones Construction Co.	Hollow Cores - 93.19% Complete	\$ 28,057.50
EFT	9/13/2016	Boyd Jones Construction Co.	Masonry - 55.12% Complete	\$218,025.00
EFT	9/13/2016	Boyd Jones Construction Co.	Mechanical - 37.36% Complete	\$152,514.00
EFT	9/13/2016	Boyd Jones Construction Co.	Pavement Striping/Sealants/Signs - 7.85% Complete	\$ 900.00
EFT	9/13/2016	Boyd Jones Construction Co.	Reinforcing - 99.30% Complete	\$ 62.39
EFT	9/13/2016	Boyd Jones Construction Co.	Roofing - 64.73% Complete	\$ 13,230.00
Subtotal - Liabilities Paid From Bond Proceeds				\$930,731.13
471	9/13/2016	Olsson Associates, Inc.	Early Site Package - 92% Complete	\$ 251.20
471	9/13/2016	Olsson Associates, Inc.	Material Testing Package - 68% Complete	\$ 4,304.65
Subtotal - Liabilities Paid From Existing Building Fund Proceeds				\$ 4,555.85
Total Building Fund Liabilities - New High School Construction - September 2016				\$935,286.98

Total Minden HS Construction/MS Renovation Billings as of 08/31/2016 - Pay App #16

Item #	Work Description	Original Budget	Owner Change Orders	CM@R Change Orders	Current Budget**	Total Work Previously Completed and Billed	Work Billed This Period	Materials Purchased and Stored	Total Completed & Stored	% Complete	Remaining Balance	Retainage
1	Pre-Bond Effort	\$6,527.00			\$6,527.00	\$6,527.00			\$6,527.00	100.00%	\$0.00	\$0.00
1	Pre-Construction Effort	\$35,960.00			\$35,960.00	\$35,858.00			\$35,858.00	100.00%	\$102.00	\$0.00
1	Construction Effort	\$574,628.00			\$574,628.00	\$385,970.43	\$29,863.00		\$415,833.43	72.37%	\$158,794.57	\$0.00
1	Reimbursable Expenses	\$302,846.00			\$302,846.00	\$98,167.35	\$8,340.55		\$106,507.90	35.17%	\$196,338.10	\$0.00
1	General Requirements	\$59,250.00			\$59,250.00	\$25,420.61			\$25,420.61	42.90%	\$33,829.39	\$2,542.06
1	Surveying	\$39,185.00			\$39,185.00	\$34,494.00	\$4,184.12		\$38,678.12	98.71%	\$506.88	\$3,867.81
1	Winter Conditions (gas, tenting, covering, blankets, thawing)	\$155,000.00			\$155,000.00	\$38,598.89			\$38,598.89	24.90%	\$116,401.11	\$3,859.89
2	Selective Demo in MS	\$50,000.00			\$50,000.00	\$52,000.00			\$52,000.00	104.00%	(\$2,000.00)	\$5,200.00
3	Concrete	\$1,907,377.00	\$14,444.00	\$2,051.00	\$1,923,872.00	\$1,021,987.60	\$255,607.00		\$1,277,594.60	66.41%	\$646,277.40	\$127,759.46
3	Reinforcing	\$225,055.00	\$670.00	\$945.00	\$226,670.00	\$225,010.00	\$69.32		\$225,079.32	99.30%	\$1,590.68	\$22,507.93
3	Hollow Cores	\$165,195.00		\$2,075.00	\$167,270.00	\$124,700.00	\$31,175.00		\$155,875.00	93.19%	\$11,395.00	\$15,587.50
3	Structural Precast	\$1,349,909.00			\$1,349,909.00	\$1,349,909.00	\$5,022.00		\$1,354,931.00	100.37%	(\$5,022.00)	\$135,493.10
4	Masonry	\$1,931,600.00			\$1,931,600.00	\$822,537.00	\$242,250.00		\$1,064,787.00	55.12%	\$866,813.00	\$106,478.70
5	Steel Fab	\$624,000.00	\$2,917.69	\$1,398.00	\$628,315.69	\$608,899.00	\$7,800.00		\$616,699.00	98.15%	\$11,616.69	\$61,669.90
5	Steel/HC/Precast Erection	\$604,550.00			\$604,550.00	\$512,150.00	\$60,000.00		\$572,150.00	94.64%	\$32,400.00	\$57,215.00
6	Woods	\$104,295.00	\$520.00		\$104,815.00				\$0.00	0.00%	\$104,815.00	\$0.00
7	Waterproofing/Weather Barriers/Sealants/Subdrainage	\$177,000.00			\$177,000.00	\$60,030.00	\$10,157.39		\$70,187.39	39.65%	\$106,812.61	\$7,018.74
7	Insulated Metal Wall Panels (to Composite Wall Panels)	\$0.00			\$0.00				\$0.00	0.00%	\$0.00	\$0.00
7	Composite Wall Panels	\$182,490.00			\$182,490.00	\$4,000.00			\$4,000.00	2.19%	\$178,490.00	\$400.00
7	Roofing	\$544,590.00			\$544,590.00	\$337,801.00	\$14,700.00		\$352,501.00	64.73%	\$192,089.00	\$35,250.10
7	Fireproofing	\$13,500.00			\$13,500.00				\$0.00	0.00%	\$13,500.00	\$0.00
7	Expansion Joint Covers	\$20,257.00			\$20,257.00		\$1,535.00		\$1,535.00	7.58%	\$18,722.00	\$153.50
8	Door/Frame/Hardware	\$345,373.00		\$10,950.00	\$356,323.00	\$235,814.00			\$235,814.00	66.18%	\$120,509.00	\$23,581.40
8	Install Doors/Frames/HW	\$78,056.00			\$78,056.00				\$0.00	0.00%	\$78,056.00	\$0.00
8	Access Doors	\$5,650.00			\$5,650.00				\$0.00	0.00%	\$5,650.00	\$0.00
8	OH and Coiling Doors	\$73,673.00			\$73,673.00				\$0.00	0.00%	\$73,673.00	\$0.00
8	Storefront and Glass	\$331,198.00		(\$8,555.00)	\$322,643.00	\$125,527.76			\$125,527.76	38.91%	\$197,115.24	\$12,552.78
9	Drywall & Framing	\$539,260.00			\$539,260.00				\$0.00	0.00%	\$539,260.00	\$0.00
9	Tiling (to Flooring)	\$0.00			\$0.00				\$0.00	0.00%	\$0.00	\$0.00
9	Acoustical Tile Ceilings & Acoustical Panels	\$192,900.00			\$192,900.00		\$3,041.99		\$3,041.99	1.58%	\$189,858.01	\$304.20
9	Flooring (LVT, Carpet, & Tile)	\$316,880.00	\$50,530.35	\$3,606.00	\$371,016.35				\$0.00	0.00%	\$371,016.35	\$0.00
9	Wood Flooring	\$122,760.00			\$122,760.00				\$0.00	0.00%	\$122,760.00	\$0.00
9	Concrete Treated Flooring Systems	\$43,115.00			\$43,115.00				\$0.00	0.00%	\$43,115.00	\$0.00
9	Painting/Air Barriers/Water Repellents	\$377,289.00			\$377,289.00				\$0.00	0.00%	\$377,289.00	\$0.00
10	Toilet Partitions/Accessories/Specialties/Visual Display Boards	\$119,580.00			\$119,580.00				\$0.00	0.00%	\$119,580.00	\$0.00
10	Visual Display Boards (to Toilet Accessories)	\$0.00			\$0.00				\$0.00	0.00%	\$0.00	\$0.00
10	Signage	\$33,649.00			\$33,649.00				\$0.00	0.00%	\$33,649.00	\$0.00
10	Lockers	\$84,350.00	(\$3,350.00)		\$81,000.00				\$0.00	0.00%	\$81,000.00	\$0.00
10	Flagpoles	\$5,280.00			\$5,280.00				\$0.00	0.00%	\$5,280.00	\$0.00
11	Knox Boxes	\$2,750.00			\$2,750.00	\$2,200.03			\$2,200.03	80.00%	\$549.97	\$220.00
11	Paint Spray Booth	\$27,650.00			\$27,650.00				\$0.00	0.00%	\$27,650.00	\$0.00
11	Stage Rigging & Curtains	\$58,406.00			\$58,406.00				\$0.00	0.00%	\$58,406.00	\$0.00
11	Athletic Equipment	\$41,150.00			\$41,150.00				\$0.00	0.00%	\$41,150.00	\$0.00
12	Educational Casework	\$380,313.00	\$4,084.50		\$384,397.50				\$0.00	0.00%	\$384,397.50	\$0.00
12	Auditorium Seating	\$75,498.00			\$75,498.00				\$0.00	0.00%	\$75,498.00	\$0.00
12	Bleachers (500 seats)	\$50,061.00			\$50,061.00				\$0.00	0.00%	\$50,061.00	\$0.00
14	Elevator	\$66,400.00			\$66,400.00	\$6,640.00			\$6,640.00	10.00%	\$59,760.00	\$664.00
21	Fire Sprinkler	\$192,500.00			\$192,500.00	\$106,800.00	\$10,000.00		\$116,800.00	60.68%	\$75,700.00	\$11,680.00
23	Mechanical	\$4,185,000.00	\$8,030.00	\$1,653.00	\$4,194,683.00	\$1,397,544.03	\$169,460.00		\$1,567,004.03	37.36%	\$2,627,678.97	\$156,700.40
26	Electrical	\$2,883,163.00	\$5,028.04	\$5,345.38	\$2,893,536.42	\$816,142.14	\$55,372.01		\$871,514.15	30.12%	\$2,022,022.27	\$87,151.42
31	Earthwork, Site Demo, Site Utilities, Erosion Control	\$683,074.00	\$3,750.00		\$686,824.00	\$397,108.75	\$65,249.95		\$462,358.70	67.32%	\$224,465.30	\$46,235.87
31	Termite Control	\$8,100.00			\$8,100.00				\$0.00	0.00%	\$8,100.00	\$0.00
31	Helical Piers	\$50,100.00			\$50,100.00	\$46,540.00			\$46,540.00	92.89%	\$3,560.00	\$4,654.00
32	Pavement Striping/Sealants/Signs	\$12,740.00			\$12,740.00		\$1,000.00		\$1,000.00	7.85%	\$11,740.00	\$100.00
32	Fencing	\$25,240.00			\$25,240.00				\$0.00	0.00%	\$25,240.00	\$0.00
32	Segmental Retaining Walls	\$66,657.00			\$66,657.00		\$24,254.00		\$24,254.00	36.39%	\$42,403.00	\$2,425.40

Total Minden HS Construction/MS Renovation Billings as of 08/31/2016 - Pay App #16

Item #	Work Description	Original Budget	Owner Change Orders	CM@R Change Orders	Current Budget**	Total Work Previously Completed and Billed	Work Billed This Period	Materials Purchased and Stored	Total Completed & Stored	% Complete	Remaining Balance	Retainage
32	Landscaping	\$66,249.00	\$50,614.00		\$116,863.00	\$13.89			\$13.89	0.01%	\$116,849.11	\$1.39
32	Utility Relocation	\$255,165.00	\$17,807.66		\$272,972.66	\$252,083.08			\$252,083.08	92.35%	\$20,889.58	\$25,208.31
32	Private Utilities	\$187,000.00	\$46,363.00		\$233,363.00	\$218,658.00			\$218,658.00	93.70%	\$14,705.00	\$21,865.80
32	Subdrainage (to Waterproofing)	\$0.00			\$0.00	\$0.00			\$0.00	0.00%	\$0.00	\$0.00
33	CMR Fee (3.28%)	\$660,575.00	\$6,606.22	\$638.57	\$667,819.79	\$368,742.20	\$26,319.53		\$395,061.73	59.16%	\$272,758.06	\$39,506.17
34	Subcontractor Bond Allowance	\$150,000.00			\$150,000.00	\$121,409.00	\$4,500.00		\$125,909.00	83.94%	\$24,091.00	\$12,590.90
35	CMR Bond	\$118,605.00	\$1,830.51	\$176.93	\$120,612.44	\$118,605.00			\$118,605.00	98.34%	\$2,007.44	\$0.00
36	2% CMR Contingency	\$432,861.00		(\$20,283.88)	\$412,577.12				\$0.00	0.00%	\$412,577.12	\$0.00
	Total	\$22,421,484.00	\$209,845.97	\$0.00	\$22,631,329.97	\$9,957,887.76	\$1,029,900.86	\$0.00	\$10,987,788.62	48.55%	\$11,643,541.35	\$1,030,445.73

** Based on October 7, 2015 GMP budget provided by Boyd Jones Construction after 100% Construction Documents were released plus/minus any approved change orders.

Bank Statement Reconciliation

Description

Adjustment Date

Adjustment Amount

Minden High School 08/01/2016 through 08/31/2016

Bank Statement Reconciliation Summary

Statement Balance	\$ 158,525.22
- Outstanding checks	\$ 13,453.97
+ Outstanding Deposits	\$ 0.00
+ Outstanding Adjustments	\$ 0.00
- Outstanding Investment Transfers	\$ 0.00
Total	<hr/> \$ 145,071.25
+ Investments	\$ 37,000.00
Book Balance	<hr/> \$ 182,071.25

Checks For Payment Listing

Date	Check Number	Payee	Reason	Amount
09/13/2016	33715	Ameritas Life Insurance Corp.	EE 403(b) Contribution Withholding	\$ 250.00
09/13/2016	33716	Annuities Service Center	EE 403(b) Contribution Withholding	\$ 250.00
09/13/2016	33717	Blue Cross Blue Shield	EE & ER Health & Dental Insurance Premiums	\$ 126,209.45
09/13/2016	33718	Horace Mann Life Insurance Company	EE 403(b) Contribution Withholding	\$ 4,175.00
09/13/2016	33719	Minden Public Schools	EE & ER Retirement Contributions	\$ 90,585.61
09/13/2016	33719	Minden Public Schools	EE Court Settlement	\$ 806.00
09/13/2016	33719	Minden Public Schools	Employee FEBA - Dependent Care	\$ 3,716.70
09/13/2016	33719	Minden Public Schools	EE Life Insurance Premiums	\$ 379.45
09/13/2016	33719	Minden Public Schools	Employee FEBA - Medical/Dental	\$ 5,310.15
09/13/2016	33719	Minden Public Schools	EE Life Insurance Premiums	\$ 500.75
09/13/2016	33720	Mps Payroll	EE & ER FICA, Medicare, & Federal Income Tax	\$ 113,650.26
09/13/2016	33721	Mps Payroll NE Income Tax	EE Nebraska Income Tax Withholding	\$ 15,454.01
09/13/2016	33722	New York Life	EE 403(b) Contribution Withholding	\$ 200.00
09/13/2016	33723	Pacific Life	EE 403(b) Contribution Withholding	\$ 300.00
09/13/2016	33724	Principal Life Insurance Company	Long-Term Disability	\$ 1,837.55
09/13/2016	33725	American Choral Directors Association	Vocal Music Membership	\$ 125.00
09/13/2016	33726	Apple Computer	MS Volume Purchasing Vouchers	\$ 500.00
09/13/2016	33727	ASK Supply Co.	Custodial Supplies	\$ 199.50
09/13/2016	33728	Aurora Cooperative	Fuel & Grounds Chemicals	\$ 694.97
09/13/2016	33729	Bill's Plumbing	East Plumbing Maintenance	\$ 48.00
09/13/2016	33729	Bill's Plumbing	East Plumbing Repair	\$ 74.96
09/13/2016	33729	Bill's Plumbing	East Sewer Cleaning	\$ 97.20
09/13/2016	33729	Bill's Plumbing	HS Janitor Closet Plumbing Repair	\$ 57.74
09/13/2016	33729	Bill's Plumbing	Locker Room Shower Repair	\$ 82.62
09/13/2016	33729	Bill's Plumbing	MS Plumbing Repair	\$ 55.60
09/13/2016	33730	Cardmember Service	HS English Books	\$ 59.44
09/13/2016	33730	Cardmember Service	HS Medical Terminology Books	\$ 926.42
09/13/2016	33730	Cardmember Service	MS Computer Supplies	\$ 127.67
09/13/2016	33730	Cardmember Service	MS Science Teaching Materials	\$ 37.95
09/13/2016	33730	Cardmember Service	Preschool On-line Software	\$ 29.95
09/13/2016	33730	Cardmember Service	Preschool Rug	\$ 263.46
09/13/2016	33730	Cardmember Service	School Nurse Supplies	\$ 213.00
09/13/2016	33731	Career Cruising	MS Careers Software	\$ 495.00
09/13/2016	33732	Carter Electric	Bus Barn Lighting Repairs	\$ 2,318.55
09/13/2016	33732	Carter Electric	Lower Locker Room Electrical	\$ 75.00
09/13/2016	33732	Carter Electric	MS Electrical Repairs	\$ 1,007.75
09/13/2016	33732	Carter Electric	Outdoor Classroom Electrical Repair	\$ 95.25
09/13/2016	33732	Carter Electric	Wrestling Gym Ballast Repair	\$ 325.40
09/13/2016	33733	Century Link Long Distance	District Long Distance	\$ 61.46
09/13/2016	33734	CenturyLink - Regular Telephone	Activities Director Telephone	\$ 7.83
09/13/2016	33734	CenturyLink - Regular Telephone	Bus Barn Telephone	\$ 2.10
09/13/2016	33735	Charter Communications	Distance Learning Services	\$ 1,041.00
09/13/2016	33736	Children's Plus	East Library Books	\$ 80.85
09/13/2016	33737	City Of Minden	Utilities	\$ 25,324.10
09/13/2016	33738	Communications Engineering, Inc.	Bus 14A&B GPS Antenna Install	\$ 314.25
09/13/2016	33739	Companion	East Library Software	\$ 799.00
09/13/2016	33739	Companion	MS Library Software	\$ 799.00
09/13/2016	33740	Conditioned Air Mechanical Systems & Service	East & HS HVAC Repair	\$ 1,276.75
09/13/2016	33740	Conditioned Air Mechanical Systems & Service	HVAC Filters	\$ 1,759.00
09/13/2016	33740	Conditioned Air Mechanical Systems & Service	MS HVAC Repair	\$ 185.00
09/13/2016	33741	Cooperative Producers, Inc.	Bus Tire Repair	\$ 40.00
09/13/2016	33742	Cornhusker International Trucks, Inc.	Bus 13A & 14B Door Glass	\$ 489.89
09/13/2016	33742	Cornhusker International Trucks, Inc.	Bus Turn Signal	\$ 125.87
09/13/2016	33743	DAS State Accounting - Central Finance	Distance Learning Services	\$ 238.96
09/13/2016	33744	Dassinger, Travis E	Bus Permit	\$ 7.50
09/13/2016	33745	Dollar General	Supplies	\$ 19.90
09/13/2016	33746	Educational Service Unit #11	4th Quarter Inservice Meals	\$ 7.89
09/13/2016	33746	Educational Service Unit #11	John Baylor Test Prep	\$ 3,465.00
09/13/2016	33747	Egan Supply Co.	Custodial Supplies	\$ 101.50
09/13/2016	33747	Egan Supply Co.	Floor Scrubber Repairs	\$ 405.66

Checks For Payment Listing

Date	Check Number	Payee	Reason	Amount
09/13/2016	33748	Fifth Street Printing	Envelope Printing	\$ 56.00
09/13/2016	33749	Foundation for Educational Services, Inc.	Website Hosting	\$ 2,700.00
09/13/2016	33750	Get Set for School	Preschool Books	\$ 271.70
09/13/2016	33751	Gibbins Telecom	East Telephone Repair	\$ 70.00
09/13/2016	33751	Gibbins Telecom	HS Telephone Repair	\$ 70.00
09/13/2016	33752	Gopher	MS PE Pedometers	\$ 1,442.60
09/13/2016	33753	Holdrege Public Schools	Marzano Training Meals	\$ 468.75
09/13/2016	33754	Hometown Leasing	Printer & Copier Lease	\$ 2,734.54
09/13/2016	33755	Hudl	Basketball Coaching Software	\$ 400.00
09/13/2016	33755	Hudl	Football Coaching Software	\$ 999.00
09/13/2016	33755	Hudl	Volleyball Coaching Software	\$ 400.00
09/13/2016	33756	John Deere Financial	Ariens Sprayer Repairs	\$ 132.78
09/13/2016	33757	JW Pepper & Son, Inc.	HS Vocal Sheet Music	\$ 181.74
09/13/2016	33758	Kearney County Health Services	Bus Driver Physical	\$ 835.00
09/13/2016	33759	Kearney Crete & Block Company	East Tuck Pointing	\$ 30.80
09/13/2016	33760	Kring, Douglas D	Rent Deposit Refund	\$ 525.00
09/13/2016	33761	Lampo Group, Inc. (The)	HS Personal Finance Textbooks	\$ 164.93
09/13/2016	33762	Landmark Implement Carquest	Ariens Mower Repair	\$ 50.81
09/13/2016	33762	Landmark Implement Carquest	Bus 13A&B Brake Repair	\$ 193.60
09/13/2016	33762	Landmark Implement Carquest	Bus 14B Tail Light	\$ 90.71
09/13/2016	33762	Landmark Implement Carquest	Miscellaneous	\$ 24.46
09/13/2016	33762	Landmark Implement Carquest	Sprayer Repair	\$ 1.32
09/13/2016	33763	Learning System (The)	HS ALS Software	\$ 5,000.00
09/13/2016	33764	LT Pedley Drug	School Nurse Supplies	\$ 379.30
09/13/2016	33765	Mason's Market	2nd Grade Supplies	\$ 32.32
09/13/2016	33765	Mason's Market	Kindergarten Supplies	\$ 16.38
09/13/2016	33765	Mason's Market	MS Life Skills Supplies	\$ 10.66
09/13/2016	33765	Mason's Market	Preschool Supplies	\$ 58.25
09/13/2016	33766	Medtox Laboratories	Bus Driver Drug Testing	\$ 84.22
09/13/2016	33767	Mid-States Automation & Control, Inc.	MS HVAC Preventative Maintenance Agreement	\$ 1,680.00
09/13/2016	33768	Minden Courier	Board Postings	\$ 270.30
09/13/2016	EFT	Minden Exchange Bank - EFT	Direct Deposit Fees	\$ 32.80
09/13/2016	33769	Minden Hardware	Repairs, Maintenance, Tools, & UPS Shipping	\$ 522.11
09/13/2016	33770	Minden Lumber & Concrete	East Elementary Repairs	\$ 219.82
09/13/2016	33770	Minden Lumber & Concrete	Field Marking Paint and Line Chalk	\$ 95.29
09/13/2016	33770	Minden Lumber & Concrete	HS Metals Shop Supplies	\$ 35.60
09/13/2016	33771	Minden Office Supply	East Nurse Cabinet Repair	\$ 35.00
09/13/2016	33771	Minden Office Supply	HS Cabinet Repair	\$ 32.99
09/13/2016	33771	Minden Office Supply	MS Supplies	\$ 5.08
09/13/2016	33772	Misko Sports	Athletics Supplies	\$ 475.50
09/13/2016	33772	Misko Sports	Boy's Basketball Supplies	\$ 922.00
09/13/2016	33772	Misko Sports	Football Supplies	\$ 749.82
09/13/2016	33772	Misko Sports	Girls Basketball Supplies	\$ 540.40
09/13/2016	33772	Misko Sports	Junior High Athletic Supplies	\$ 320.10
09/13/2016	33772	Misko Sports	Softball Supplies	\$ 473.68
09/13/2016	33772	Misko Sports	Track Supplies	\$ 336.80
09/13/2016	33772	Misko Sports	Volleyball Supplies	\$ 592.50
09/13/2016	33772	Misko Sports	Wrestling Supplies	\$ 686.30
09/13/2016	33773	Mower Medic, LLC	Walker Mower Gear Box Repair	\$ 122.54
09/13/2016	33774	Napa Auto Parts	01 Walker Mower Oil	\$ 11.58
09/13/2016	33774	Napa Auto Parts	Bus 5A Repair	\$ 138.37
09/13/2016	33774	Napa Auto Parts	Bus Repairs	\$ 18.30
09/13/2016	33774	Napa Auto Parts	Bus Wiper Blades	\$ 95.92
09/13/2016	33774	Napa Auto Parts	Bus Wiper Blades	\$ 85.92
09/13/2016	33774	Napa Auto Parts	Marty J Mower Repair	\$ 4.82
09/13/2016	33774	Napa Auto Parts	Van 5V1 Wiper Blades & Windshield Washer Fluid	\$ 52.79
09/13/2016	33775	NASB ALICAP	Insurance Premium	\$ 104,096.00
09/13/2016	33776	National Association for Music Education	HS Vocal Music Membership Dues	\$ 122.00
09/13/2016	33777	National Geographic Bee	National Geography Bee Registration	\$ 100.00
09/13/2016	33778	Ne Association School Boards	Administrative Assistant Membership Dues	\$ 25.00

Checks For Payment Listing

Date	Check Number	Payee	Reason	Amount
09/13/2016	33778	Ne Association School Boards	Area Membership Meeting Registrations	\$ 504.00
09/13/2016	33779	Ne Speech Language Hearing	NSLHA Fall Conference Registration	\$ 200.00
09/13/2016	33780	Nebraska Central Equipment	Bus 5A Stop Arm	\$ 324.60
09/13/2016	33781	Nebraska Department of Education.	CCR Math Transition Workshop	\$ 25.00
09/13/2016	33782	Nebraska Fire Sprinkler Corp	MS Fire Sprinkler Repair	\$ 443.00
09/13/2016	33783	Nebraska PowerSchool User Group	Nebraska PowerSchool User's Group Registration	\$ 60.00
09/13/2016	33784	Nebraska Safety Center	Level I & Level II Transportation Courses	\$ 375.00
09/13/2016	33785	North Central Air, Inc.	Air Compressor Repair	\$ 27.40
09/13/2016	33786	NSBA - Membership	NSBA Annual Membership	\$ 65.00
09/13/2016	33787	One Source	August Background Checks	\$ 141.00
09/13/2016	33788	Pearson Clinical Assessment	WISC-V & BASC Scoring Subscriptions	\$ 288.00
09/13/2016	33789	Perma-Bound	MS Library Books	\$ 77.32
09/13/2016	33790	Perry, Guthery, Haase & Gessford, P.C., L.L.O	Legal Services	\$ 114.00
09/13/2016	33791	Presto-X Company	Pest Control Services	\$ 119.48
09/13/2016	33792	Pureland Supply, LLC	HS Smart Board Lamps	\$ 433.00
09/13/2016	33793	Renaissance Learning	East AR Reading Software Renewal	\$ 2,087.00
09/13/2016	33793	Renaissance Learning	MS AR Reading Software Renewal	\$ 2,490.00
09/13/2016	33794	Rob Armstrong	Golf Balls	\$ 1,043.20
09/13/2016	33795	Scholastic Magazines	East Scholastic Magazines	\$ 615.31
09/13/2016	33795	Scholastic Magazines	HS Scholastic Magazines	\$ 421.93
09/13/2016	33795	Scholastic Magazines	MS Scholastic Magazines	\$ 174.24
09/13/2016	33796	School Outfitters	HS Health Class Stools	\$ 171.89
09/13/2016	33797	Schoology, Inc.	MS Schoology Software Subscription	\$ 7,500.00
09/13/2016	33798	Scotchman Industries	HS Metals Shop Blade Sharpening	\$ 57.01
09/13/2016	33799	Source Gas, LLC	Activity Building Natural Gas	\$ 270.16
09/13/2016	33799	Source Gas, LLC	Bus Barn Natural Gas	\$ 47.78
09/13/2016	33799	Source Gas, LLC	East Natural Gas	\$ 256.43
09/13/2016	33799	Source Gas, LLC	HS Natural Gas	\$ 259.03
09/13/2016	33799	Source Gas, LLC	MS Natural Gas	\$ 801.05
09/13/2016	33800	Supplyworks	Custodial Supplies	\$ 112.67
09/13/2016	33801	TAESE/USU	Region Special Education Monitoring Meeting	\$ 50.00
09/13/2016	33802	tenBensel, Michelle J	Google Summit Meal	\$ 16.46
09/13/2016	33803	Welton Diesel	Bus 13A 80-Day Inspection & Maintenance	\$ 408.07
09/13/2016	33803	Welton Diesel	Bus 13A Brake Repairs	\$ 150.00
09/13/2016	33803	Welton Diesel	Bus 13B 80-Day Inspection & Maintenance	\$ 408.07
09/13/2016	33803	Welton Diesel	Bus 13B Brake Repairs	\$ 150.00
09/13/2016	33803	Welton Diesel	Bus 14A 80-Day Inspection & Maintenance	\$ 408.07
09/13/2016	33803	Welton Diesel	Bus 14B 80-Day Inspection & Maintenance	\$ 408.07
09/13/2016	33804	Woodward's Disposal Service, Inc.	Shredding Service	\$ 52.00
09/13/2016	33805	Wright Express Fleet Services	Fuel Purchases	\$ 431.81
09/13/2016	33806	Zaner-Bloser, Inc.	MS Spelling Books	\$ 397.27
Subtotal				\$ 560,796.39
Net Payroll - September 2016				\$ 306,449.42
Total General Fund Disbursements - September 2016				\$ 867,245.81

Secretary _____



NEBRASKA

DEPARTMENT OF EDUCATION

www.education.ne.gov
301 Centennial Mall South
P.O. Box 94987
Lincoln, NE 68509-4987
TEL 402.471.2295
FAX 402.471.0117

August 8, 2016

Melissa Wheelock
Minden Public Schools
520 W 3rd, PO Box 301
Minden, NE 68959-0301

Dear Dr. Wheelock,

On August 5, 2016 the Nebraska Board of Education voted to approve your early childhood program for the period of July 1, 2016 through June 30, 2017. This action follows a recommendation by the Office of Early Childhood and is based upon records indicating that your district operated an early childhood program in compliance with the requirements in Rule 11, Regulations for Early Childhood Education Programs, for the 2015-16 school year.

The 2016-17 school year is year 11 of approval for your district. Your district's Early Childhood program has met the required 3 consecutive years of approval to become a qualified early childhood education program. This means that 4 year-olds eligible to attend kindergarten in the following year will be included in the fall membership count for the calculation of TEEOSA. Please refer to the listing on the NDE website at http://www.education.ne.gov/oec/pdfs/nssrs_template.pdf to assist you in identifying the early childhood participation info code(s) to be used on the NSSRS Programs Fact Template for 2016-17.

We commend you on your commitment to provide a high quality early childhood experience for the children and families enrolled in the program. If you have any questions about Rule 11 or the approval process, please contact the Early Childhood Specialist assigned to your area. Please refer to the map on the NDE website at http://www.education.ne.gov/oec/B_5_programs.html.

Sincerely,

A handwritten signature in cursive script that reads "Melody A. Hobson".

Melody A. Hobson
Administrator
Office of Early Childhood

Superintendent's Report

September 2016

Board Hearings 7:30 PM C.L. Jones Middle School Media Center
Board meeting immediately following the budget and tax hearing

Board Hearings

Two hearings will take place before the board meeting on Tuesday:

- *Hearing on the school budget

- *Hearing on the tax levy

2016-17 District Budget

The proposed 2016-17 budget was printed and advertised in the Courier, and the final budget will be sent to the department of education on September 14th.

ALICAP Meetings and Reports

The district met with the ALICAP safety manager in regard to safety issues in and around the school. Each year he inspects at least one of the buildings and makes recommendations to the district safety committee. This year the safety manager visited CLJones. His recommendations were reviewed and will be followed through by Dave Schoone and John Osgood.

Preschool

The Nebraska Board of Education approved our early childhood program. Our preschool is year 11 of approval for our district. This means that 4 year-olds eligible to attend kindergarten in the following year will be included in the fall membership count for state aid calculation.

Minden Public Schools Board of Education Report September, 2016

August enrollment numbers at East Elementary reflect an attendance of 234 students.

Kindergarten-54 students

First grade-66 students

Second grade-60 students

Third grade-54 students

On August 17th, East hosted an informational parent night in which parents met their child's new teacher. Each grade level teacher explained rules and procedures to the parents. Mrs. Petersen also led a meeting concerning the qualifications and services provided by the Title I program.

The preschool hosted an open house for preschool students on August 22nd. Students and their families were invited to come tour the preschool and get to know the teacher.

Students in first through third grade have completed the Measurement of Academic Progress assessment. The assessment results in the fall are used to guide instruction and provide a baseline to monitor student achievement of skills in the areas of reading, language, and math. Kindergarten students will complete this assessment later in September after students become more familiar with operating a computer mouse.

The Nebraska State Fair served as Nebraska's largest classroom on September 1st when East Elementary students visited in Grand Island. Students in first through third grade experienced sheep shearing, a white tiger show, the birthing pavilion, the milking parlor, petting zoo, and many other state fair sights.

The kindergarten students took part in fun of their own while having a fun in the sun day on September 1st. They spent a day enjoying themes from the ocean (since it was "o" week) such as sand, water, and beach toys. They smiled all day from ear to ear.

Officer Kring assisted East Elementary students with an internal lockdown, fire drill, and off site evacuation drill. The students and staff carried out the emergency response plans, and Officer Kring expressed how impressed he was at how swiftly and quietly the entire building responded to each drill. The fire drill to evacuate the entire building took just over one minute.





Minden Public Schools Board of Education

Monthly School Board Meeting (September 2016) Mr. Hosick-Principal's Report

1. Start of the School Year:

The first month of the school year has blown by. Students and staff are settling in and we appear to be busy as ever. We have a nice group of freshman in the building this year and we also have a few new students in the halls this year. Our "unofficial" 9-12 enrollment appears to be:

9th grade	52
10th grade	59
11th grade	50
12th grade	56
13th grade	4*

221 students

*(Life skills students and students completing graduation requirements.)

2. ACT Testing Data :

In a recent report from ACT, the 2016 Minden High students who took the ACT last school year posted a composite score of 21.4 . Minden High's composite score is equal to the state's average composite score. The breakdown per academic area is listed below. I have also attached a more detailed summary issued directly from ACT with my report.

<u>2016 ACT Data:</u>	<u>Minden</u>	<u>State</u>
English	19.8	20.9
Math	21.8	20.8
Reading	22.3	21.8
Science	21.2	21.5
<hr/>		
Composite Score	21.4	21.4

3. ACT to replace NeSA Test at High School:

During the September, 2nd board meeting the Nebraska State Board of Education selected ACT company to provide the standardized college entrance exam for Nebraska students in the 11th grade. Beginning in the spring of 2017, the exam will be administered to all high school juniors and will replace the current Nebraska State Accountability (NeSA) assessment at that grade level. In April 2016, the Nebraska Legislature passed Legislative Bill 930 requiring public school students in the 11th grade to take a college admission test. In addition, the requirement for a statewide writing assessment will end after the 2016-17 school year and will be replaced with a statewide reading English Language Arts assessment, containing a writing component. The ACT will provide students with a score that can be used at colleges or universities to contribute to application and admission decisions.

4. Chromebooks at the High School

The Chromebook deployment at high school went well. We have received some very positive feedback from students, teachers, and parents about the new Chromebooks. We have noticed an increased usage in the classrooms by the students and staff, which is very encouraging. We will keep you updated on our progress with our technology usage as the year continues. I would like to once again thank the Board of Education for their support with the purchase of our new Chromebooks.

Tech Club Report

September, 2016

The Tech Club held its annual fall sports bar-b-que on Sept. 2nd, at the Gibbon vs. Minden home football opener. We had a super fan turnout, and our students did a great job of serving , running the concession stand, and cleaning up. Our winter sports bar-b-que will be held on Tues., Dec. 6th, a home game against Lexington.

The club is also planning two smaller bar-b-que events. We will be serving pork sandwiches to the construction workers at the new high school later this month. We will also be serving sandwiches to the help at Minden Machine Shop. They have been VERY helpful and generous to our program this last year.

We are planning to take our tech club trip to Denver this year. We will be leaving Thurs. Oct. 27, and we will tour Mile High Stadium and Coors Field the next day. We also hope to include the Pepsi Center if possible.

Our first community service – school service project of the year is to build two trailer-type picnic tables. They will be 20ft. long, with a running gear and 15 in. wheels. They will be available for school and community functions free of charge. Some of the metal will be donated by Chief Industries, and the remainder will be purchased by the club.

Bob Carlson

Rick Chramosta

College Readiness Letter for: MINDEN HIGH SCHOOL

August 24, 2016
Code: 281525

PRINCIPAL
MINDEN HIGH SCHOOL
325 YATES AVE
MINDEN, NE 68959



011061110

This report reflects the achievement of your graduates on the ACT over time and an indication of the extent to which they are prepared for college-level work. The ACT consists of curriculum-based tests of educational development in English, mathematics, reading, and science designed to measure the skills needed for success in first-year college coursework. Table 1 shows the five-year trend of your ACT-tested graduates. Beginning with the 2013 Graduating Class, all students whose scores are college reportable, both standard and extended time tests, are included in this report.

Table 1: Five Year Trends - Average ACT Scores

Grad Year	Total Tested		English		Mathematics		Reading		Science		Composite	
	School	State	School	State	School	State	School	State	School	State	School	State
2012	36	16,581	22.3	21.8	22.5	21.7	23.9	22.3	22.4	21.9	22.9	22.0
2013	35	17,745	21.3	21.1	21.7	21.1	22.3	21.8	21.9	21.5	21.9	21.5
2014	45	17,768	23.6	21.3	22.5	21.1	23.5	22.0	22.9	21.7	23.2	21.7
2015	30	18,347	22.2	21.1	22.9	21.0	22.0	21.9	22.6	21.6	22.5	21.5
2016	41	18,598	19.8	20.9	21.8	20.8	22.3	21.8	21.2	21.5	21.4	21.4

Figure 1. Percent of ACT-Tested Students Ready for College-Level Coursework

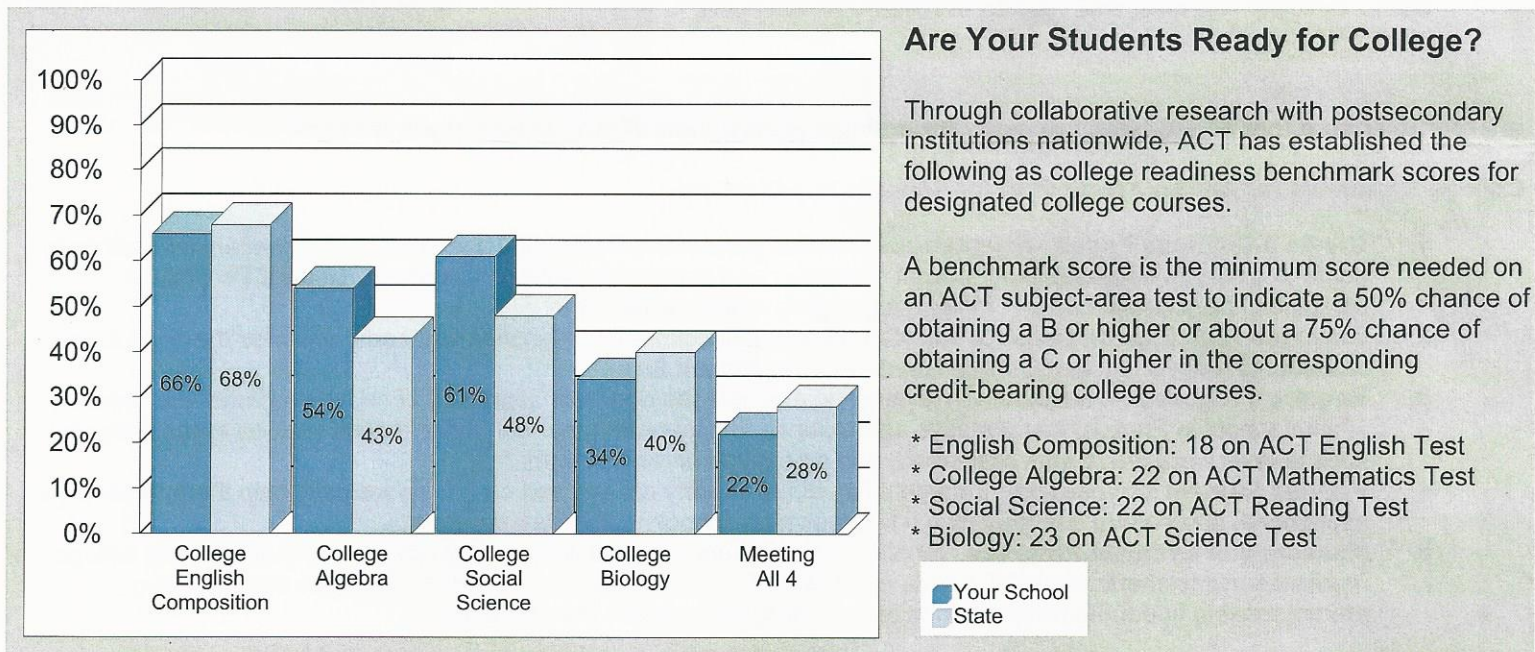

A District College Readiness Letter has been sent to the Superintendent of the district.

College Readiness Letter for: MINDEN HIGH SCHOOL

ACT Research has shown that it is the rigor of coursework - rather than simply the number of core courses - that has the greatest impact on ACT performance and college readiness. Figures 2 and 3 report the value added by increasingly rigorous coursework in mathematics and science respectively.

Figure 2. Average ACT Mathematics Scores by Course Sequence

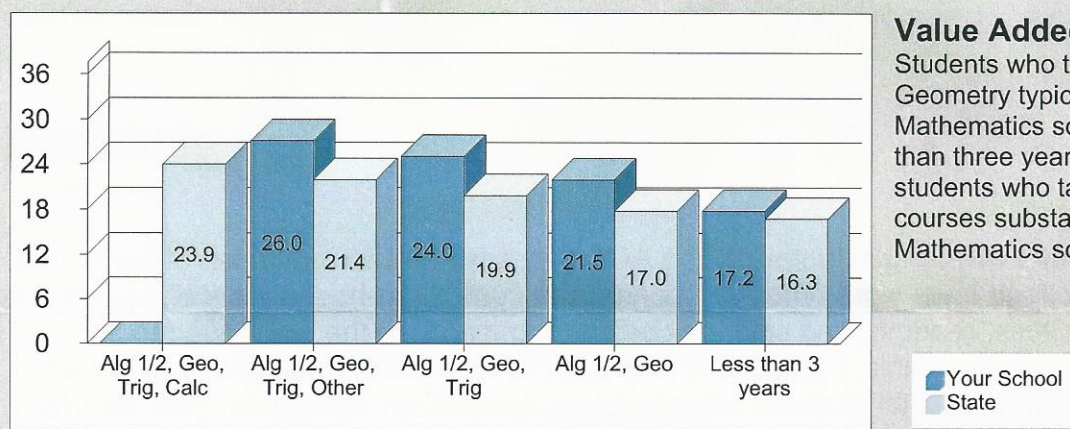

Value Added by Mathematics Courses

Students who take Algebra 1, Algebra 2, and Geometry typically achieve higher ACT Mathematics scores than students who take less than three years of mathematics. In addition, students who take more advanced mathematics courses substantially increase their ACT Mathematics score.

Figure 3. Average ACT Science Scores by Course Sequence

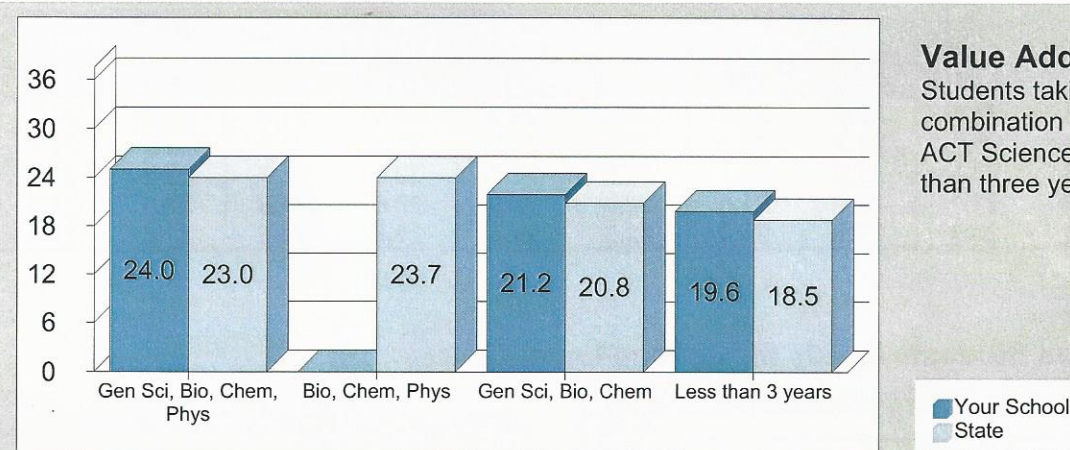

Value Added by Science Courses

Students taking Biology and Chemistry in combination with Physics typically achieve higher ACT Science scores than students taking less than three years of science courses.

In order to ensure that all students are ready for college, an overview of vital action steps is provided.

College Readiness for All: An Action Plan for Schools and Districts

1. **Create a Common Focus.** Establish collaborative partnerships with local and state postsecondary institutions to come to a shared understanding of what students need to know for college readiness. Use ACT's College Readiness Benchmarks as a common language to define readiness.
2. **Establish High Expectations for All.** Create a school culture that identifies and communicates the need for all students to meet or exceed College Readiness Benchmark Scores.
3. **Require a Rigorous Curriculum.** Review and evaluate the rigor and alignment of courses offered and required in your school in English, mathematics, and science to ensure that the foundational skills leading to readiness for college-level work are taught, reaffirmed, and articulated across courses.
4. **Provide Student Counseling.** Engage all students in early college and career awareness, help them to set high aspirations, and ensure that they plan a rigorous high school coursework program.
5. **Measure and Evaluate Progress.** Monitor and measure every student's progress early and often using college readiness assessments like ACT Aspire and the ACT. Make timely interventions with those students who are not making adequate progress in meeting College Readiness Benchmarks.

To learn more about these recommended action steps and ACT programs that will help improve college readiness for your students, contact ACT Customer Service at 319-337-1309 or customerservices@act.org.

National

2016 State Percent of High School Graduates Tested, Average Composite Score, and Percent Meeting Benchmarks by Subject

State	Percent of Graduates Tested*	Average Composite Score	Percent Meeting English Benchmark	Percent Meeting Reading Benchmark	Percent Meeting Math Benchmark	Percent Meeting Science Benchmark
Alabama	100	19.1	51	34	23	24
Colorado	100	20.6	61	42	39	36
Illinois	100	20.8	64	42	41	36
Kentucky	100	20.0	59	40	31	30
Louisiana	100	19.5	58	35	26	27
Michigan	100	20.3	60	40	36	35
Minnesota	100	21.1	61	45	46	40
Mississippi	100	18.4	46	27	20	19
Missouri	100	20.2	59	40	35	32
Montana	100	20.3	56	41	38	32
Nevada	100	17.7	37	26	21	18
North Carolina	100	19.1	47	34	32	26
North Dakota	100	20.3	58	41	38	33
South Carolina	100	18.5	44	30	25	21
Tennessee	100	19.9	58	38	30	30
Utah	100	20.2	59	42	35	33
Wisconsin	100	20.5	60	41	41	37
Wyoming	100	20.0	58	38	33	31
Arkansas	96	20.2	60	40	32	30
Hawaii	94	18.7	46	30	30	23
Nebraska	88	21.4	68	48	43	40
Oklahoma	82	20.4	61	45	32	32
Florida	81	19.9	53	42	33	29
South Dakota	76	21.9	70	53	51	46
Kansas	74	21.9	70	53	48	43
Ohio	73	22.0	69	53	49	45
New Mexico	70	19.9	53	39	31	28
Iowa	68	22.1	73	55	48	46
West Virginia	67	20.7	67	46	32	33
Georgia	60	21.1	65	47	40	36
Arizona	58	20.1	55	39	38	31
Alaska	53	20.0	55	42	37	31
Texas	46	20.6	57	43	42	35

Art

The art I classes are busy learning perspective and how to shade, turning a 2-D shape into a form. They designed their names in perspective and will complete this project with shading their names.

Art II - they are learning about the different techniques of watercolor. They have made an abstract landscape and are busy designing a bug in which they will watercolor.

Art III - She has completed an Expressionistic portrait and is now starting on practicing drawing facial features.

Ceramic students just finished reading and testing over the book learning the vocabulary and where items are in the art room. they have started a whistle using the pinch technique, and will start the wheel next week.

Adv Ceramics just finished making 6 mugs to refresh their throwing skills, and are working on designing a t-pot.

I have have Independent Study Students that work independently along side other classes that are in progress and their first project is due this week. I'm seeing anything from acrylic paintings, to wire sculptures, to drawings.

Art Club will have their first meeting this next week. We will elect officers and plan our fall activities. These include a fund raiser, Halloween House building and concession stands.

C. L. Jones Middle School

MPS Board of Education Report

September 2016

1. CLJMS Marzano PD Day, CLJMS Media Center, Friday, September 2, 2016, 2:20 PM [CLJMS Professional Development September 2, 2016 Slides](#)

Marzano - Lesson Segments - Design Questions - Elements

Prior to the September 2nd

1. Teachers completed the [Teacher Self-Rating 41 Elements](#) survey on the first 13 elements. Reference pages in *Becoming a Reflective Teacher*, BART, begin on page 83
2. Prior to the PD, teachers reviewed the first 13 elements by completing the evaluations in [Design Question 1](#), [Design Question 2](#), [Design Question 6](#). These are the Teacher Scales for Reflective Practice. In BART, they begin on page 185

During the professional development time

1. [Team & Color Marzano](#) - Teams were formed. The teams discuss how they have used the first 13 elements, as well as strategies from the Marzano training they have used thus far.
Nicole, Brea, Buck, Barb, & Steph - [Buck and the BART Babes Orange](#)
Karen, Donnie, Shawn, Connie, & Morgan - Team "N"
Rita, Whitney, Joann, Michelle, & Ben - Purple Dawgs
Robin, Lisa, Dan, Carla, & Sue - Blueberry Bluebirds
Beth, Katie, Taylor, Kylee, Jade, & Colleen - Green Turtles
2. Teachers selected one of the first 13 elements, from design questions 1, 2, & 6, as a September/October teaching goal (Marzano Job Target). Team members were not obligated to select the same element.
3. [Learning Goals Discussed](#) - Teams discussed how they set Learning Goals and how they will be displayed in their classrooms. In addition, they list roadblocks to achieving this goal. Marzano (Learning Goals) [Designing Learning Goals](#)

Setting Teaching Goal / Marzano Job Target

1. Teachers worked individually, or with other teachers completing their Marzano Job Target. The form all teachers will complete is called [Bart Goal Setting and Reflection](#). Teachers will fill out Steps 2 & 3, and share it with Mr. Osgood by Friday, September 9, 2016.

Announcements

- **Suicide Prevention Training**

You are receiving this email because you are required to complete the **mandatory** Nebraska Dept. of Education suicide prevention training. This training is required through Legislative Bill 923.

The training takes approximately 45 minutes. You can complete each short module at different times, and it does not have to be completed in one sitting. If you completed the training last year, this is the same program and qualifies as your yearly recertification.

Here are the instructions to complete the training:

- 1) Go to: <https://nebraska.kognito.com> (Suicide Prevention Training)
- 2) If you were required to take the training last year, you can enter your email address and password from last year.

If you do not remember your password from last year, please click on "reset password."

If this is your **first** time taking the training, please click on "click here to create account."

3) After logging in, choose a course: Elementary, Middle School, or High School. If you are in multiple buildings, pick the building you are in the majority of your time.

Those that are **recertifying**: After selecting your course, click on "**recertifying 'i'**" in orange font. It will show you how to reset the course.

4) Hit "**launch**" in orange to start your course.

5) When you are finished with all modules, please print off your certificate of completion and turn in to your principal.

Custodians - please give your certificate to your building principals.

- **SOCS Homescreen Instructions**

The students can add the new website to their iPads by simply typing in www.mindenwhippets.org. They will be prompted to add the site to their Homescreen. The mobile app for the new website will be available in about 2 weeks.

- **CLJMS Shirts must be paid for by the end of the day, Tuesday, September 6, 2016. Get your order and money to Barb.**

- **Let Shawn know the apps you need. He is not bothered by your emails. He will get things pushed out.**

2) Schoology Training, Friday, August 26th

On August 26th, Jody Bauer, ESU#11 Instruction Technology Coach, came to CLJMS to work with staff members on Schoology. Jody arrived at 1:00 PM and stayed until 4:00 PM working with our staff.

On August 1st, 18 CLJMS staff members participated in a day long workshop with professional training from Schoology. After this initial training staff felt additional individualized training would be very helpful.

The plan:

1:00 to 1:35 meet with JO on Schoology Management

1:35 to 2:10 meet with Shawn Wheelock, Robin Hollinger, Steph Emery, Sue Yant & Whitney Maulsby

2:15 to finished Beth Christensen, Jade Olson, Kylee Stepp, Katie Gilson, Taylor Dreher, Karen Space, Joann Paulsen, & Nicole Schoone

These people are our core group. They will train other teachers as they become masters at using Schoology with their students.

3) Marzano Direction Mtg, CLJMS, Friday, August 19th

This meeting was open to any teacher who could attend and was interested in helping frame the CLJMS strategy for working with Marzano teaching/learning strategies. Since it was the first Friday, of the first week, I thought I would have three or four people attend. I was wrong. Great staff.

Marzano Meeting 8/19/16

Paulsen, Space, Clapper, Schoone, Martin, Hollinger, tenBensel, Gilson, Maulsby, Dreher, Christensen, Thatcher, Olson, Stepp, Emery, & Osgood

Implementation ideas:

- learning goals posted in all classroom - PD time
- Job target related to Marzano assignment. Can have more than one element up to the teacher.
- Visible learning chart charting teacher progress toward meeting and using an element(s)
- Look at putting together teams.

Concepts discussed:

- 1) Goal setting from reflective teacher. This will be done at the end of the day and may work well for Job Targets.
- 2) identify what one does well in a particular Design Question, and then select one to improve.
- 3) Page 8 is about learning objectives and their purpose. Use this for the staff meeting.
- 4) Beginning and ending of class. 3 minutes at the beginning and 3 at the end. They need to be mini lessons at the beginning and exit activities at the end of the lesson. They are only as valuable as you make them as a teacher.
- 5) learning goals cover the unit of time. Learning objectives are daily and relate to the over all learning goal. Setting learning goals and getting them posted is a great use of PD days.

MINDEN PUBLIC SCHOOLS
ACTIVITIES/ATHLETIC DEPARTMENT

*Phillip Hoyt, Assistant Principal
Activities Director*

*325 North Yates Avenue
Minden, NE 68959-1598
308-832-2254 School
308-832-1892 Fax*

SEPTEMBER 2016-17 BOARD MEETING
ACTIVITIES DIRECTOR REPORT

Activities at Minden Public Schools are underway as we move into September. We will continue to encourage athletes, students, parents and patrons to demonstrate good sportsmanship at our home and away games this year by announcing sportsmanship reminders at the beginning of contests and encouraging everyone to support our athletes, coaches and officials in a positive manner.

Varsity Football is 1-1 as they were defeated by Ogallala in their season opener and had a great win over Gibbon last week. They travel to Southern Valley on Friday Sept 9 and then play Adams Central at home on Friday Sept 16. The JV football team defeated Southern Valley in their first opener. The JV team will host Kearney Catholic on Monday Sept 16.

Volleyball competed at all 3 levels of C/JV/V this past week having much success. The Varsity won its opener against Lexington on Thursday Sept 1. They competed at their own Invitational on Saturday Sept 3 defeating Valentine and Ainsworth the first two games and then were defeated by GICC in the finals match. They defeated Phillipsburg at home on Thursday Sept 8 at all 3 levels and will compete on Saturday Sept 10 in a JV/V matchup with Axtell here at home. The varsity is 4-1 on the season right now. 9/JV will be at home on Monday Sept 12 with Broken Bow, Kearney Catholic and Holdrege.

Cross Country competed at their own Minden Invite on Saturday Sept 3 in Varsity, JV and Jr. High competition. They boys team finished in runner-up place behind Aurora. Individual medalists in the top 15 were Aiden Wheelock 2nd, Rodrigo Jauregui 5th, Colton Taylor 6th, Alex Olson 7th, Jay Maska 8th, Lucas Lahr 10th, Brandon Saunders 11th and Jack Loucks 15th. The girls team finished in 3rd behind Gothenburg and Aurora. Michaela Sinsel was 7th, Kristen Sindel 9th, and Jaden Donely 15th. Jr. high boy runners in the top 15 include Konner Verbeck 3rd and Jesse Gruber 15th. Jr. high girl runners in the top 15 were Brenna Braithwait 1st, Abbey Rehtus 2nd, Neidhe Vazquez 3rd, Alaina Suchsland 5th, Riley Saunders 8th, Sarah Hultquist 10th, Katelyn Althouse 12th. The next meet for all levels will be on Saturday Sept 10 at the Broken Bow Invite.

Girls Golf has competed in 7 meets this fall and have continued to improve each week.

Girls competing for Minden this year are: Taylor Kissinger, Isabella VanDusen, Kaitlyn Koch, and Brinn Space.

1. McCook Invite – Taylor Kissinger 12th.
2. Holdrege Quad - Taylor Kissinger 2nd.
3. GICC Invite 10th - Taylor Kissinger 2nd.
4. Cozad Triangular with Holdrege
5. Lexington Invite and Aurora Invites

They will continue action on Thursday Sept 15 at the Gothenburg Invite.

Softball has competed in 10 games so far this fall with a 1-9 record. The team finished in 6th place at the Holdrege Invite and showed a lot of improvement. They are working hard and are looking to improve as they continue their season. They compete at the Cozad Invite on Saturday Sept 10.

Jr. High Football and Volleyball have been practicing hard for their first contests.

Jr. High Volleyball played against Cozad on the Sept 9th and will compete against Adams Central on Sept 15th.

Jr. High Football plays at Gothenburg on Sept 13 in 7th and 8th grade games.

The Minden High School Band has been practicing hard and preparing for halftime entertainment and marching competitions this fall. They performed at halftime of the Gibbon football game and will perform at halftime of all the home varsity football games, the Homecoming Parade, Harvest of Harmony Parade in Grand Island, Minden Band Fest and the NSBA State Marching Competition in Oct.

Play Production has begun tryouts for their upcoming season and will perform in November and December. We look forward to a great fall season of activities and good luck to our teams and organizations.

NOTICE OF BUDGET HEARING AND BUDGET SUMMARY

State of Nebraska
Budget Form - NBH-School District
 Statement of Publication

Minden Public Schools (50-0503) in Kearney County, Nebraska

PUBLIC NOTICE is hereby given, in compliance with the provisions of State Statute Sections 13-501 to 13-513, that the governing body will meet on the 12th day of September, 2016 at 7:30 o'clock, P.M., at C.L. Jones Middle School Media Center for the purpose of hearing support, opposition, criticism, suggestions or observations of taxpayers relating to the following proposed budget and to consider amendments relative thereto. The budget detail is available at the office of the Clerk/Secretary during regular business hours.

Ken Carpenter

Clerk/Secretary

FUNDS	Actual Disbursements & Transfers		Actual/Estimated Disbursements & Transfers		Budgeted Disbursements & Transfers		Necessary Cash Reserve (4)	Total Available Resources Before Property Taxes (5)	Fee and Delinquent Tax Allowance (6)	Total Personal and Real Property Tax Requirement (7)
	2014-2015 (1)	2015-2016 (2)	2015-2016 (2)	2016-2017 (3)						
General	\$ 9,644,298.00	\$ 10,576,866.38	\$ 10,576,866.38	\$ 12,264,686.80	\$ 1,100,000.00	\$ 4,844,981.12	\$ 86,057.55	\$ 8,605,763.23		
Depreciation	\$ -	\$ -	\$ -	\$ 1,934,542.19	\$ -	\$ 1,934,542.19				
Employee Benefit	\$ -	\$ -	\$ -	\$ 35,336.00	\$ -	\$ 35,336.00				
Contingency	\$ -	\$ -	\$ -	\$ -	\$ -	\$ -				
Activities	\$ 324,609.00	\$ 289,512.17	\$ 289,512.17	\$ 474,179.26	\$ -	\$ 474,179.26				
School Nutrition	\$ 319,447.00	\$ 319,689.00	\$ 319,689.00	\$ 465,245.00	\$ -	\$ 465,245.00				
Bond	\$ 343,764.00	\$ 274,611.00	\$ 274,611.00	\$ 1,423,392.75	\$ 450,000.00	\$ 453,029.00	\$ 14,347.09	\$ 1,434,710.84		
Special Building	\$ 1,279,821.00	\$ 9,624,374.00	\$ 9,624,374.00	\$ 16,591,227.00	\$ -	\$ 16,311,227.00	\$ 2,828.28	\$ 282,828.28		
Qualified Capital Purpose Undertaking	\$ 35.00	\$ 5.00	\$ 5.00	\$ 10.00	\$ -	\$ 10.00	\$ -	\$ -		
Cooperative	\$ -	\$ -	\$ -	\$ -	\$ -	\$ -	\$ -	\$ -		
Student Fee	\$ 7,664.00	\$ 12,394.51	\$ 12,394.51	\$ 12,105.72	\$ -	\$ 12,105.72	\$ -	\$ -		
TOTALS	\$ 11,919,638.00	\$ 21,097,452.06	\$ 21,097,452.06	\$ 33,200,724.72	\$ 1,550,000.00	\$ 24,530,655.29	\$ 103,232.92	\$ 10,323,302.35		

Total Personal and Real Property Tax Requirement For Bonds
\$ 1,434,710.84

Total Personal and Real Property Tax Requirement for ALL Other
\$ 8,888,591.51

2016-2017 TAX REQUEST RESOLUTION
FOR
MINDEN PUBLIC SCHOOL DISTRICT 0503

WHEREAS, public notice was given at least five days in advance of a Special Public Hearing called for the purpose of discussing and approving or modifying the District's Tax Request for the 2016-2017 school fiscal year for the General Fund, Bond Fund, and Special Building Fund of Kearney County School District 0503; and,

WHEREAS, such Special Public Hearing was held before the Board of Education (hereinafter "the Board") of Kearney County School District 0503 (hereinafter "the District") at the time, date, and place announced in the notice published in a newspaper of general circulation, a copy of which notice and proof of publication of which is attached hereto as Exhibit A, all as required by law; and,

WHEREAS, the Board, provided an opportunity to receive comment, information, and evidence from persons in attendance at such Special Public Hearing; and

WHEREAS, the Board, after having reviewed the District's Tax Request for each said fund, and after public consideration of the matter, has determined that the Final Tax Request as listed below are necessary in order to carry out the functions of the District, as determined by the Board for the 2016-2017 school fiscal year.

NOW BE IT THEREFORE RESOLVED THAT (1) the Tax Request for the General Fund should be, and hereby is set at \$8,605,763.23 for the 2016-2017 school fiscal year; (2) the Tax Request for the Bond Fund should be, and hereby is set at \$1,434,710.84 for the 2016-2017 school fiscal year; and (3) the Tax Request for the Special Building Fund should be, and is hereby set at \$282,828.28 for the 2016-2017 school fiscal year.

It is so moved by _____ and seconded by _____ this 12th day of September 2016. Roll Call Vote as follows:

Craig Grams	Yes ____	No ____	Absent ____
Richard Jacobsen	Yes ____	No ____	Absent ____
Kevin Raun	Yes ____	No ____	Absent ____
Rusty Rhynalds	Yes ____	No ____	Absent ____
Ken Carpenter	Yes ____	No ____	Absent ____
Justin Glanzer	Yes ____	No ____	Absent ____

The undersigned herewith certifies, as Secretary of the Board of Education of Kearney County School District 0503, that the above resolution was duly adopted by a majority vote of said Board at a duly constituted public meeting of said Board.

_____, Secretary

Notice of Special Hearing To Set Final Tax Request

Mindon Public Schools (50-0503) in Kearney County, Nebraska

PUBLIC NOTICE is hereby given, in compliance with the provisions of State Statute Section 77-1601.02, that the governing body will meet on the 12th day of September 2016 at 7:30 o'clock P.M., at C.L. Jones Middle School Media Center for the purpose of hearing support, opposition, criticism, suggestions or observations of taxpayers relating to setting the final tax request at a different amount than the prior year tax request.

2015/16 Budget Information

2016/17 Budget Information

Fund	2015-2016 Property Tax Request	2015 Tax Rate	Property Tax Rate (2015-2016 Request Divided By 2016 Valuation)	2016-2017 Proposed Property Tax Request	Proposed 2016 Tax Rate
General Fund	7,772,655.88	0.559274	0.549285	8,605,763.23	0.608160
Bond Fund(s) K - 12	1,060,606.05	0.076315	0.074952	1,434,710.84	0.101389
Bond Fund(s) K - 8			0.000000		0.000000
Bond Fund(s) 9 - 12			0.000000		0.000000
Bond Fund			0.000000		0.000000
Special Building Fund	1,515,151.50	0.109021	0.107074	282,828.28	0.019987
Qualified Capital Purpose Undertaking Fund K - 12			0.000000	-	0.000000
Qualified Capital Purpose Undertaking Fund K - 8			0.000000		0.000000
Qualified Capital Purpose Undertaking Fund 9 - 12			0.000000		0.000000

StudentsDrug and Substance Use and Prevention**Drug-Free Schools**

The District shall implement regulations and practices which will ensure compliance with the Drug-Free Schools and Communities Act and all regulations and rules promulgated pursuant thereto. The District's safe and drug-free schools program is established in accordance with principles of effectiveness as required by law to respond to such harmful effects.

Education and Prevention

The District promotes comprehensive, age appropriate, developmentally based drug and alcohol education and prevention programs, which will include in the curriculum the teaching of both proper and incorrect use of drugs and alcohol for all students in all grades of this School District. Further, the District will have proper in-service orientation and training for all employed staff.

Standards of Conduct; Notice to Students and Parents

Students are to be provided a copy of the standards of conduct for student behavior in the District which prohibit the unlawful possession, use, or distribution of illicit drugs and alcohol on school premises or as a part of any of the school's activities. It shall be the further policy of the District to keep a file showing receipt of standards of conduct and a statement of disciplinary sanctions that may be taken for violations of such standards of conduct. The receipt shall be signed by both student and parent or guardian and returned to the respective Principal. It shall contain in prominent letters the following language:

"RECEIPT SHALL SERVE TO DEMONSTRATE THAT YOU AS PARENT OR GUARDIAN OF A STUDENT ATTENDING MINDEN PUBLIC SCHOOLS HAVE RECEIVED NOTICE OF THE STANDARDS OF CONDUCT OF THIS DISTRICT EXPECTED OF STUDENTS CONCERNING THE ABSOLUTE PROHIBITION AGAINST THE UNLAWFUL POSSESSION, USE, OR DISTRIBUTION OF ILLICIT DRUGS AND ALCOHOL ON SCHOOL PREMISES OR AS A PART OF ANY OF THE SCHOOL'S ACTIVITIES AS DESCRIBED IN BOARD POLICY OR ADMINISTRATIVE REGULATION. THIS NOTICE IS BEING PROVIDED TO YOU PURSUANT TO P.L. 101-226 AND 34 C.F.R. PART 86, BOTH FEDERAL LEGAL REQUIREMENTS FOR THE DISTRICT TO OBTAIN ANY FEDERAL FINANCIAL ASSISTANCE. YOUR SIGNATURE ON THIS RECEIPT ACKNOWLEDGES THAT YOU AND YOUR CHILD OR CHILDREN WHO ARE STUDENTS ATTENDING THIS DISTRICT FULLY UNDERSTAND THE DISTRICT'S POSITION ABSOLUTELY PROHIBITING THE UNLAWFUL POSSESSION, USE, OR DISTRIBUTION OF ILLICIT DRUGS AND ALCOHOL ON SCHOOL PREMISES OR AS A PART OF THE SCHOOL'S ACTIVITIES AS HEREIN ABOVE DESCRIBED AND THAT COMPLIANCE WITH THESE STANDARDS IS MANDATORY. ANY NON-COMPLIANCE WITH THESE STANDARDS CAN AND WILL RESULT IN PUNITIVE MEASURES BEING TAKEN AGAINST ANY STUDENT FAILING

TO COMPLY WITH THESE STANDARDS."

Drug and Alcohol Education and Prevention Program of the District Pursuant to the Safe and Drug-Free Schools and Communities Laws and Regulations

Students are to be provided an age appropriate, developmentally based drug and alcohol education and prevention program. The program educates on the adverse effects of the use of illicit drugs and alcohol, with the primary objective being the prevention of illicit drug and alcohol use by students.

Drug and Alcohol Counseling, Rehabilitation and Re-entry Programs

Students are to be provided information concerning available drug and alcohol counseling, rehabilitation, and re-entry programs within sixty miles of the administrative offices of the District or, where no such services are found, within the State of Nebraska. Information concerning such resources shall be presented to all of the students of the District upon request by the counselor.

In the event of disciplinary proceedings against any student for any District policy pertaining to the prohibition against the unlawful possession, use, or distribution of illicit drugs and alcohol, appropriate school personnel shall confer with any such student and his or her parents or guardian concerning available drug and alcohol counseling, rehabilitation, and re-entry programs that appropriate school personnel shall consider to be of benefit to any such student and his or her parent or parents or guardian.

Safe and Drug-Free Schools-- Parental Notice of Right to Withdraw

Parents will be notified that, if upon receipt of information regarding the content of safe and drug free school programs and activities other than classroom instruction a parent objects to the participation of their child in such programs and activities, the parent may notify the School District of such objection in writing. Upon the receipt of such notice the student will be withdrawn from the program or activity to which parental objection has been made.

Standards of Student Conduct Pertaining to the Possession, Use, or Distribution of Illicit Drugs, Alcohol or Tobacco.

These standards are in addition to standards of student conduct elsewhere adopted by board policy or administrative regulation. The District's standards prohibit the possession, use, or distribution of illicit drugs, alcohol or tobacco on school premises, in school vehicles, or as a part of any of the school's activities on or off school premises. Conduct prohibited at places and activities as hereinabove described shall include, but not be limited to, the following:

1. Possession, use distribution or being under the influence of any controlled substance, including but not limited to marijuana, any narcotic drug, any hallucinogen, any stimulant, or any depressant.
2. Possession of any prescription drug in an unlawful fashion.
3. Possession, use, distribution or being under the influence of alcohol.
4. Possession, use, distribution, or being under the influence of any abusable glue or aerosol paint or any other chemical substance for inhalation, including but not limited to lighter fluid, whiteout, and reproduction fluid, when such activity constitutes a substantial interference with school purposes.
5. Possession, use, or distribution of any look-alike drug or look-alike controlled

substance when such activity constitutes a substantial interference with school purposes.

6. Possession, use or distribution of any tobacco product.

Disciplinary Sanctions

Violation of any of the above prohibited acts will result in disciplinary sanction being taken within the bounds of applicable law, up to and including short term suspension, long term suspension, expulsion, and referral to appropriate authorities for criminal prosecution. In particular, students should be aware that:

1. Violation of these standards may result in suspension or expulsion.
2. Prohibited substances will be confiscated and turned over to law enforcement authorities.
3. The student may be referred for counseling or treatment.
4. Parents or legal guardian will be notified.
5. Law enforcement will be notified.
6. If it appears there is imminent danger to the student, other students, school personnel, or students involved, emergency medical services will be contacted.

Intervention

The Minden Public School District does not have the authority or responsibility to make medical or health determinations regarding chemical dependency. However, when observed behavior indicates that a problem exists which may affect the student's ability to learn or function in the educational climate or activity, the school then has the right and responsibility to refer the student for a formal chemical dependency diagnosis based on behavior observed by school staff. The school will issue a statement to all students and employed staff that the use of illicit drugs and the unlawful possession and use of alcohol is wrong and harmful. The school shall make available to students and employed staff information about any drug and alcohol counseling, and rehabilitation and re-entry programs, which are available to students.

Administration

The administration is authorized to adopt such administrative rules, regulations or practices necessary to properly implement this policy. Such regulations, rules or practices may vary the procedures set forth herein to the extent necessary to fit the circumstances of an individual situation.

Such rules, regulations and practices may include administrative forms, such as checklists to be used by staff to record observed behavior and to determine the proper plan of action.

Date of Adoption: [Insert Date]



Melissa Wheelock <melissa.wheelock@mindenwhippets.org>

Tech Club Trip

1 message

Bob Carlson <bob.carlson@mindenwhippets.org>

Thu, Sep 8, 2016 at 3:10 PM

To: Melissa Wheelock <melissa.wheelock@mindenwhippets.org>

The Minden High Tech Club requests school board approval for a trip to Denver on Oct. 27th and 28th. We are planning to tour both Mile High Stadium and Coors Field. We also hope to include the Pepsi Center. Thanks for your consideration.

Bob Carlson



Boyd Jones Construction
4360 Nicholas St.
Omaha, Nebraska 68131
Phone: (402) 553-1804
Fax: (402) 561-7705

Project: 13-047 - Minden Public Schools
622 W. 3rd St.
Minden, Nebraska 68959

Prime Contract Change Order #013a: PCO#52a

Table with contract details including TO: Minden Public Schools, FROM: Boyd Jones Construction Company, DATE CREATED: 8/25/2016, CONTRACT STATUS: Pending - In Review, etc.

DESCRIPTION: Provide modifications to the contract documents as indicated in PCO#52.

ATTACHMENTS:

CHANGE ORDER REQUESTS IN THIS CHANGE ORDER:

Table with 4 columns: COR #, Title, Schedule Impact, Amount. Row 1: 013a, PCO#52a, 0 days, \$90,000.00. Total: \$90,000.00

CHANGE ORDER LINE ITEMS:

PCO # 052a : Terrazzo at Commons

Table with 5 columns: #, Cost Code, Description, Type, Amount. Includes items for Resilient Flooring, Terrazzo, and CMR Contingency, plus Subtotal, Fee, Bond, and Grand Total.

The original (Contract Sum) \$ 22,421,484.00
Net change by previously authorized Change Orders \$ 216,895.40
The contract sum prior to this Change Order was \$ 22,638,379.40
The contract sum will be changed by this Change Order in the amount of \$ 90,000.00
The new contract sum including this Change Order will be \$ 22,728,379.40
The contract time will not be changed by this Change Order by 0 days

Jason Schmitz (DLR Group - Omaha)
6457 Frances Street, Suite 200
Omaha Nebraska 68106-2280

Minden Public Schools
520 West 3rd St.
Minden Nebraska 68959

Boyd Jones Construction Company
4360 Nicholas, P.O. Box 31336
Omaha Nebraska 68131

SIGNATURE DATE SIGNATURE DATE SIGNATURE DATE



Boyd Jones Construction
4360 Nicholas St.
Omaha, Nebraska 68131
Phone: (402) 553-1804
Fax: (402) 561-7705

Project: 13-047 - Minden Public Schools
622 W. 3rd St.
Minden, Nebraska 68959

Prime Contract Potential Change Order #052a: Terrazzo at Commons

TO:	Minden Public Schools 520 West 3rd St. Minden Nebraska, 68959	FROM:	Boyd Jones Construction Company 4360 Nicholas, P.O. Box 31336 Omaha Nebraska, 68131
PCO NUMBER/REVISION:	052a / 0	CONTRACT:	1 - Kearney County School District Prime Contract
REQUEST RECEIVED FROM:	Melissa Wheelock (Minden Public Schools)	CREATED BY:	Tim Meyer (Boyd Jones Construction Company)
STATUS:	Pending - In Review	CREATED DATE:	8/25 /2016
REFERENCE:		PRIME CONTRACT CHANGE ORDER:	#013a - PCO#52a
FIELD CHANGE:	No	CHANGE ORDER REQUEST:	#013a - PCO#52a
LOCATION:	Area C	ACCOUNTING METHOD:	Amount Based (G702/G703)
SCHEDULE IMPACT:	0 days	PAID IN FULL:	No
		TOTAL AMOUNT:	\$90,000.00

POTENTIAL CHANGE ORDER TITLE: Terrazzo at Commons

CHANGE REASON: Client Request

POTENTIAL CHANGE ORDER DESCRIPTION: *(The Contract Is Changed As Follows)*

Provide 3/8" epoxy terrazzo (Terroxy Epoxy Matrix) at Commons Area as indicated on attached CO#13a Terrazzo Plan. Pattern to be the same as the original LVT. Chips in terrazzo to be domestic marble...not glass.

ATTACHMENTS:

[CO#13a Terrazzo Plan.pdf](#)

#	Cost Code	Description	Type	Amount
1	9-650 - Resilient Flooring	Delete LVT	Sub Contracts	(\$13,885.20)
2	9-400 - Terrazzo	Terrazzo at Commons	Sub Contracts	\$ 89,262.00
3	1-018	CMR Contingency	Other	\$ 11,004.79
Subtotal:				\$86,381.59
Fee: 3.28% on Fringes, Sub Contracts, Equipment, Material, Other, and Labor				\$ 2,833.32
Bond: 0.88% on Fringes, Sub Contracts, Equipment, Material, Other, and Labor				\$ 785.09
Grand Total:				\$90,000.00

CO#13a

- INTERIOR FINISH PLAN GENERAL NOTES**
- INTERIOR FINISH PLAN GENERAL NOTES APPLY TO ALL INTERIOR FINISH PLAN SHEETS.
 - NOT ALL FLOOR AND WALL FINISHES ARE NOTED ON THE INTERIOR FINISH PLANS. SEE ROOM FINISH SCHEDULE FOR FLOOR AND WALL FINISHES NOT NOTED.
 - FLOOR PATTERN DIMENSIONS AND LOCATIONS ARE APPROXIMATE. MINOR ADJUSTMENTS MAY BE MADE FOR LAYOUT AND TO MINIMIZE WASTE AS LONG AS THE DESIGN INTENT IS MAINTAINED.
 - FOR FLOOR TILE PRODUCTS, ADJUST LAYOUT AS NECESSARY TO AVOID USING CUT WIDTHS THAT EQUAL LESS THAN ONE-HALF OF A TILE AT ROOM PERIMETER.
 - HATCH PATTERNS ARE FOR FLOOR PATTERN CLARIFICATION PURPOSES ONLY.

 = 3/8" epoxy terrazzo

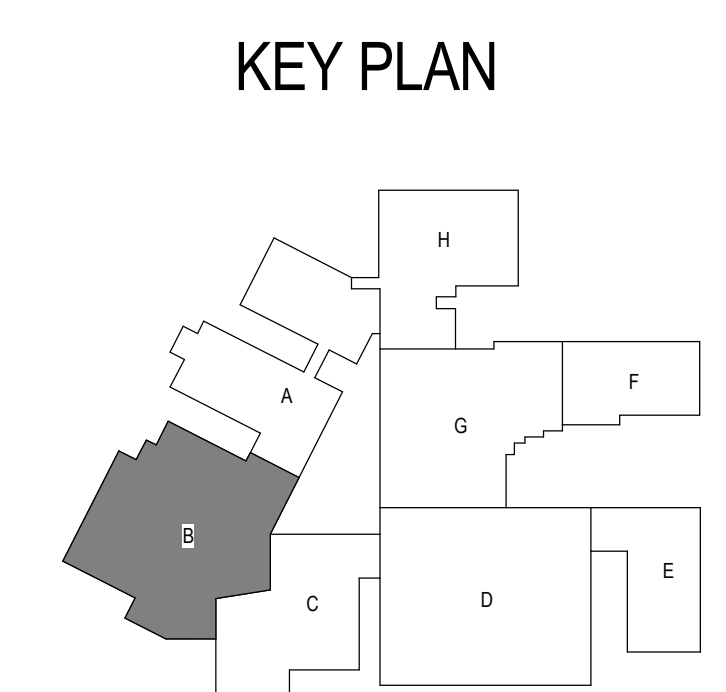
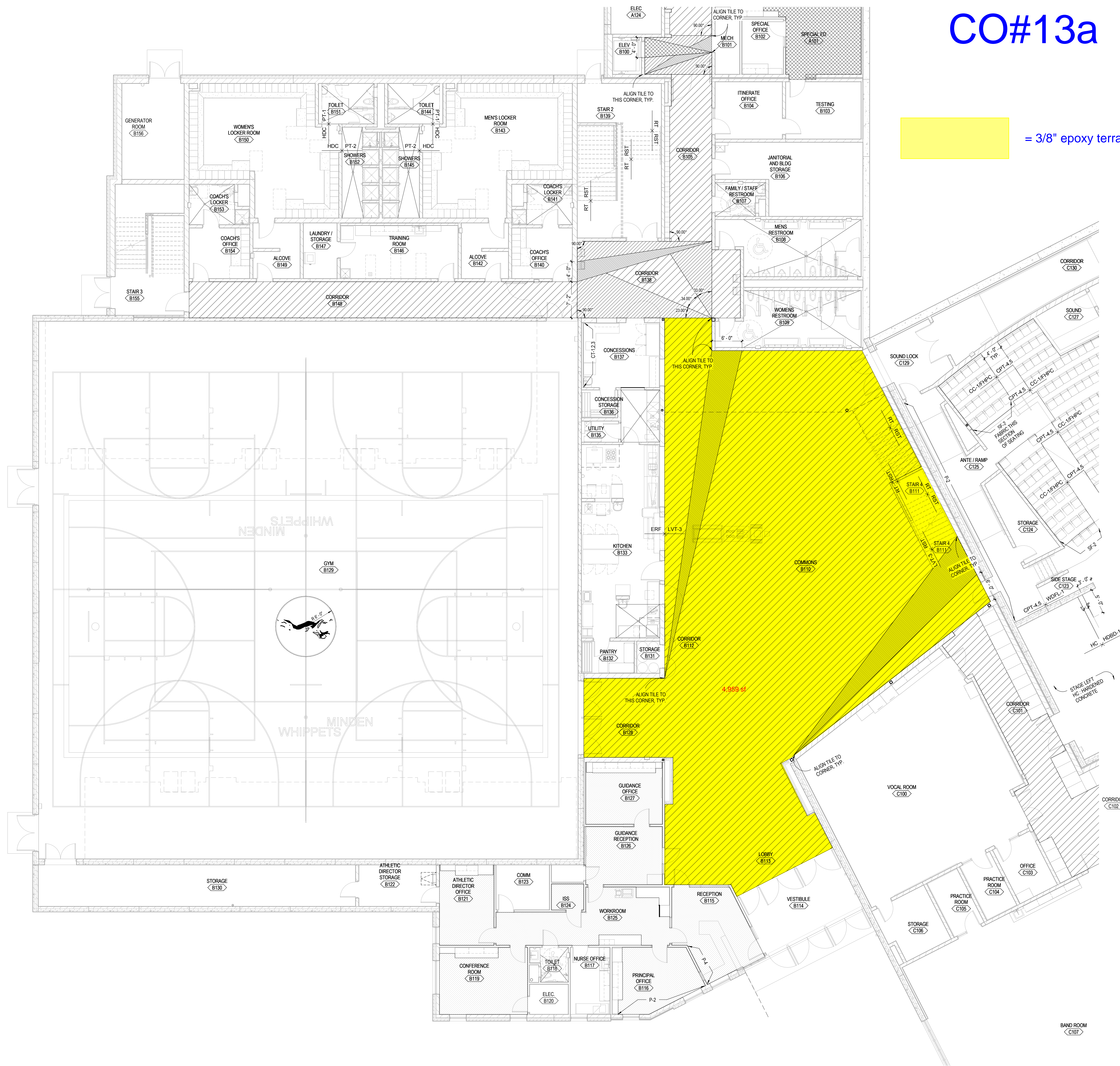
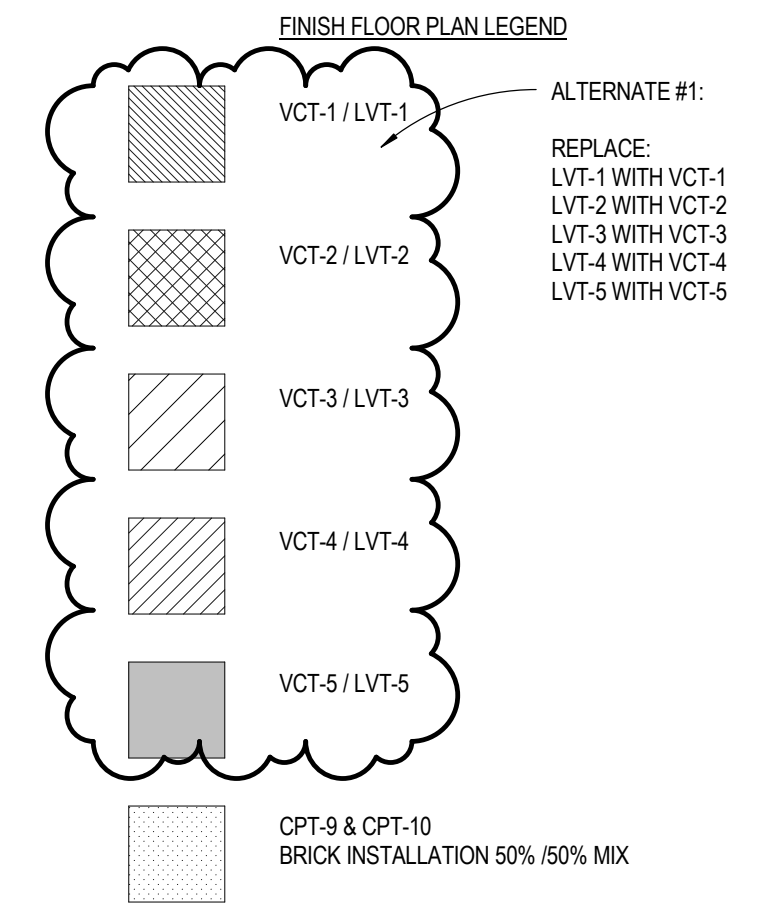

FINISH FLOOR PLAN, MAIN LEVEL - AREA B
MINDEN NEW HIGH SCHOOL & MIDDLE SCHOOL RENOVATION
FINAL CONSTRUCTION DOCUMENTS

A13.1B
 10-15104-00
 8-5-2015
 Revision

DLR Group
 Architecture Engineering Planning Interiors
 © 2015, DLR Group Inc. A Nebraska corporation. ALL RIGHTS RESERVED.

C:\Revit\15104-00_AR_2015_Central_smls.rvt
 8/7/2015 10:02:23 AM

FINISH FLOOR PLAN, MAIN LEVEL - AREA B
 SCALE: 1/8" = 1'-0"





Boyd Jones Construction
4360 Nicholas St.
Omaha, Nebraska 68131
Phone: (402) 553-1804
Fax: (402) 561-7705

Project: 13-047 - Minden Public Schools
622 W. 3rd St.
Minden, Nebraska 68959

Prime Contract Change Order #013b: PCO#52b

Table with contract details including TO: Minden Public Schools, FROM: Boyd Jones Construction Company, DATE CREATED: 9/08/2016, CONTRACT STATUS: Pending - In Review, etc.

DESCRIPTION: Provide modifications to the contract documents as indicated in PCO#52b.

ATTACHMENTS:

CHANGE ORDER REQUESTS IN THIS CHANGE ORDER:

Table with 4 columns: COR #, Title, Schedule Impact, Amount. Row 1: 013b, PCO#52b, 0 days, \$99,006.10. Total: \$99,006.10

CHANGE ORDER LINE ITEMS:

PCO # 052b : Terrazzo @ Commons & B138

Table with 5 columns: #, Cost Code, Description, Type, Amount. Includes line items for Resilient Flooring, Terrazzo, and CMR Contingency, plus Subtotal, Fee, Bond, and Grand Total.

Summary table showing contract sum changes: The original (Contract Sum) \$22,421,484.00, Net change by previously authorized Change Orders \$216,895.40, etc.

Jason Schmitz (DLR Group - Omaha)
6457 Frances Street, Suite 200
Omaha Nebraska 68106-2280

Minden Public Schools
520 West 3rd St.
Minden Nebraska 68959

Boyd Jones Construction Company
4360 Nicholas, P.O. Box 31336
Omaha Nebraska 68131

SIGNATURE DATE SIGNATURE DATE SIGNATURE DATE



Boyd Jones Construction
4360 Nicholas St.
Omaha, Nebraska 68131
Phone: (402) 553-1804
Fax: (402) 561-7705

Project: 13-047 - Minden Public Schools
622 W. 3rd St.
Minden, Nebraska 68959

Prime Contract Potential Change Order #052b: Terrazzo @ Commons & B138

TO:	Minden Public Schools 520 West 3rd St. Minden Nebraska, 68959	FROM:	Boyd Jones Construction Company 4360 Nicholas, P.O. Box 31336 Omaha Nebraska, 68131
PCO NUMBER/REVISION:	052b / 0	CONTRACT:	1 - Kearney County School District Prime Contract
REQUEST RECEIVED FROM:	Melissa Wheelock (Minden Public Schools)	CREATED BY:	Tim Meyer (Boyd Jones Construction Company)
STATUS:	Pending - In Review	CREATED DATE:	9/8 /2016
REFERENCE:		PRIME CONTRACT CHANGE ORDER:	None
FIELD CHANGE:	No	CHANGE ORDER REQUEST:	None
LOCATION:	Area B	ACCOUNTING METHOD:	Amount Based (G702/G703)
SCHEDULE IMPACT:	0 days	PAID IN FULL:	No
		TOTAL AMOUNT:	\$99,006.10

POTENTIAL CHANGE ORDER TITLE: Terrazzo @ Commons & B138

CHANGE REASON: Client Request

POTENTIAL CHANGE ORDER DESCRIPTION: *(The Contract Is Changed As Follows)*

Provide 3/8" epoxy terrazzo (Terroxy Epoxy Matrix) at Commons Area and B138 as indicated on attached CO#13b Terrazzo Plan. Pattern to be the same as the original LVT. Chips in terrazzo to be domestic marble...not glass.

ATTACHMENTS:

[CO#13b Terrazzo Plan.pdf](#)

#	Cost Code	Description	Type	Amount
1	9-650 - Resilient Flooring	Delete LVT	Sub Contracts	(\$15,478.40)
2	9-400 - Terrazzo	Provide 3/8" epoxy terrazzo	Sub Contracts	\$ 99,504.00
3	1-018	CMR Contingency	Other	\$ 11,000.00
Subtotal:				\$95,025.60
Fee: 3.28% on Fringes, Sub Contracts, Equipment, Material, Other, and Labor				\$ 3,116.84
Bond: 0.88% on Fringes, Sub Contracts, Equipment, Material, Other, and Labor				\$ 863.66
Grand Total:				\$99,006.10



Boyd Jones Construction
4360 Nicholas St.
Omaha, Nebraska 68131
Phone: (402) 553-1804
Fax: (402) 561-7705

Project: 13-047 - Minden Public Schools
622 W. 3rd St.
Minden, Nebraska 68959

Prime Contract Change Order #013c: PCO#52c

Table with contract details including TO: Minden Public Schools, FROM: Boyd Jones Construction Company, DATE CREATED: 9/08/2016, CONTRACT STATUS: Pending - In Review, etc.

DESCRIPTION: Provide modifications to the contract documents as indicated in PCO#52c.

ATTACHMENTS:

CHANGE ORDER REQUESTS IN THIS CHANGE ORDER:

Table with 4 columns: COR #, Title, Schedule Impact, Amount. Includes a TOTAL row showing \$105,071.56.

CHANGE ORDER LINE ITEMS:

PCO # 052c : Terrazzo @ Commons, B138 & B105

Table with 5 columns: #, Cost Code, Description, Type, Amount. Lists items like Resilient Flooring, Terrazzo, and CMR Contingency with a Grand Total of \$105,071.56.

The original (Contract Sum) \$ 22,421,484.00
Net change by previously authorized Change Orders \$ 216,895.40
The contract sum prior to this Change Order was \$ 22,638,379.40
The contract sum will be changed by this Change Order in the amount of \$ 105,071.56
The new contract sum including this Change Order will be \$ 22,743,450.96
The contract time will not be changed by this Change Order by 0 days

Jason Schmitz (DLR Group - Omaha)
6457 Frances Street, Suite 200
Omaha Nebraska 68106-2280

Minden Public Schools
520 West 3rd St.
Minden Nebraska 68959

Boyd Jones Construction Company
4360 Nicholas, P.O. Box 31336
Omaha Nebraska 68131

SIGNATURE DATE SIGNATURE DATE SIGNATURE DATE



Boyd Jones Construction
4360 Nicholas St.
Omaha, Nebraska 68131
Phone: (402) 553-1804
Fax: (402) 561-7705

Project: 13-047 - Minden Public Schools
622 W. 3rd St.
Minden, Nebraska 68959

Prime Contract Potential Change Order #052c: Terrazzo @ Commons, B138 & B105

Table with 4 columns: Field Name, Value, Field Name, Value. Includes fields like TO, FROM, PCO NUMBER/REVISION, CONTRACT, REQUEST RECEIVED FROM, CREATED BY, STATUS, CREATED DATE, REFERENCE, PRIME CONTRACT CHANGE ORDER, FIELD CHANGE, CHANGE ORDER REQUEST, LOCATION, ACCOUNTING METHOD, SCHEDULE IMPACT, PAID IN FULL, and TOTAL AMOUNT.

POTENTIAL CHANGE ORDER TITLE: Terrazzo @ Commons, B138 & B105

CHANGE REASON: Client Request

POTENTIAL CHANGE ORDER DESCRIPTION: (The Contract Is Changed As Follows)

Provide 3/8" epoxy terrazzo (Terroxy Epoxy Matrix) at Commons Area, B138, and B105 as indicated on attached CO#13c Terrazzo Plan. Pattern to be the same as the original LVT. Chips in terrazzo to be domestic marble...not glass.

ATTACHMENTS:

CO#13c Terrazzo Plan.pdf

Table with 5 columns: #, Cost Code, Description, Type, Amount. Lists items like Resilient Flooring, Terrazzo, and CMR Contingency with their respective amounts and a grand total of \$105,071.56.

CO#13c

- INTERIOR FINISH PLAN GENERAL NOTES**
- INTERIOR FINISH PLAN GENERAL NOTES APPLY TO ALL INTERIOR FINISH PLAN SHEETS.
 - NOT ALL FLOOR AND WALL FINISHES ARE NOTED ON THE INTERIOR FINISH PLANS. SEE ROOM FINISH SCHEDULE FOR FLOOR AND WALL FINISHES NOT NOTED.
 - FLOOR PATTERN DIMENSIONS AND LOCATIONS ARE APPROXIMATE. MINOR ADJUSTMENTS MAY BE MADE FOR LAYOUT AND TO MINIMIZE WASTE AS LONG AS THE DESIGN INTENT IS MAINTAINED.
 - FOR FLOOR TILE PRODUCTS, ADJUST LAYOUT AS NECESSARY TO AVOID USING CUT WIDTHS THAT EQUAL LESS THAN ONE-HALF OF A TILE AT ROOM PERIMETER.
 - HATCH PATTERNS ARE FOR FLOOR PATTERN CLARIFICATION PURPOSES ONLY.

 = 3/8" epoxy terrazzo

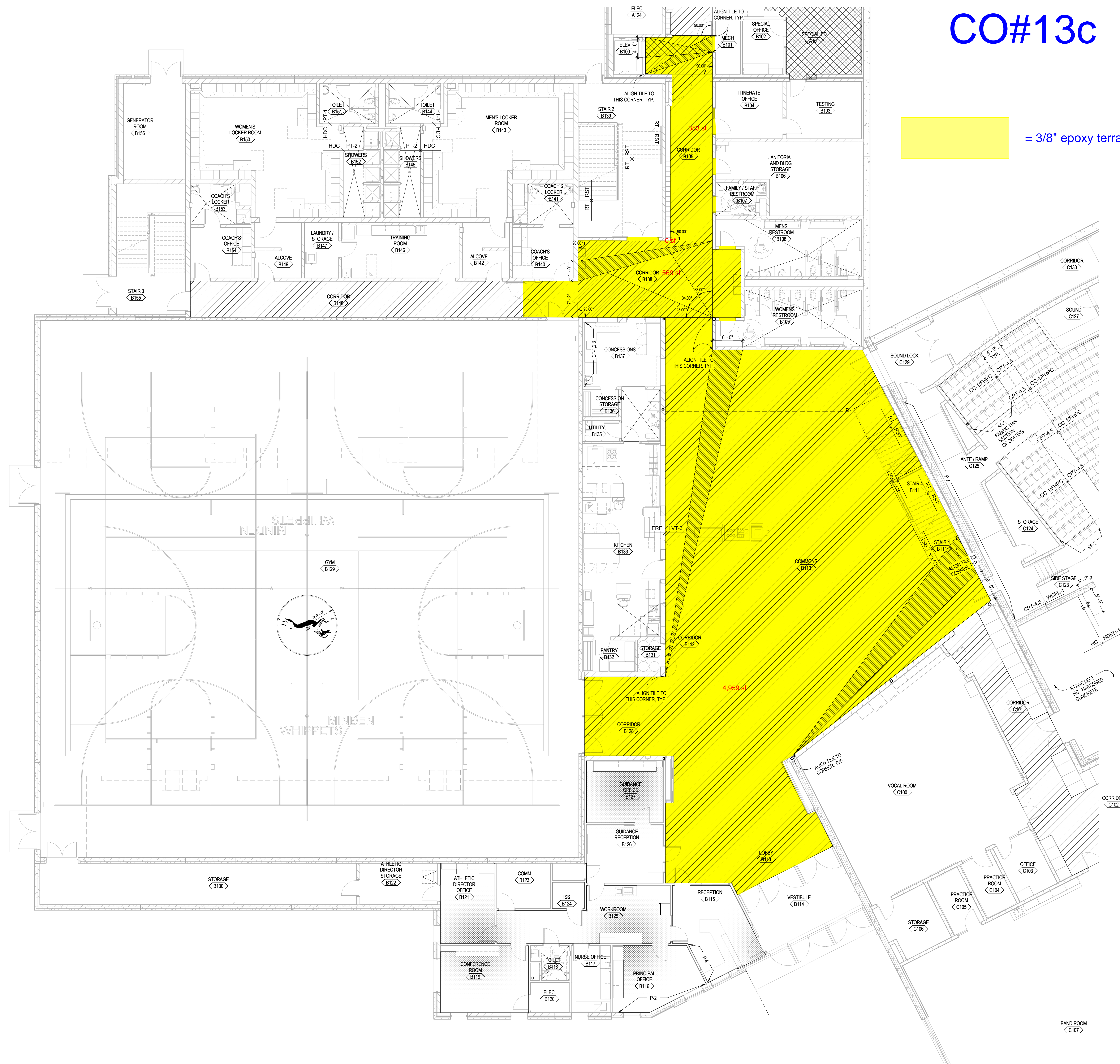
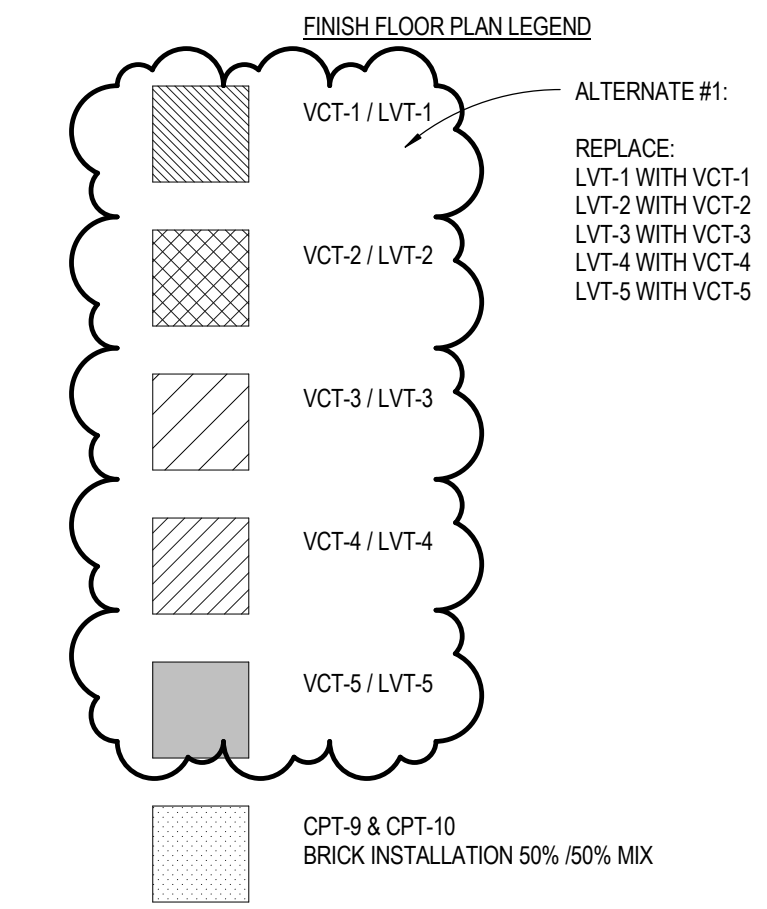

KEY PLAN

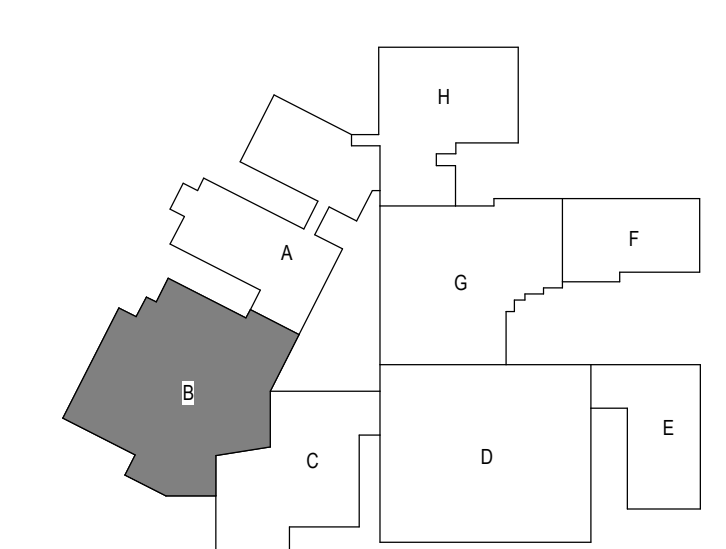

FINISH FLOOR PLAN, MAIN LEVEL - AREA B
MINDEN NEW HIGH SCHOOL & MIDDLE SCHOOL RENOVATION
FINAL CONSTRUCTION DOCUMENTS

A13.1B
 10-15104-00
 8-5-2015
 Revision

FINISH FLOOR PLAN, MAIN LEVEL - AREA B
 SCALE: 1/8" = 1'-0"

C:\Revit\15104-00_A13.1B_Central_sml.rvt
 8/7/2015 10:02:23 AM

Agenda item

Discuss, consider and take action regarding ratification of change orders and construction change directives for the new Minden High School building project approved pursuant to the Minden Public Schools – Board of Education Protocol Re: 2014 Bond Issue Projects – Construction Change Orders and Construction Change Directives.

MOTION REGARDING REATIFICATION OF CHANGE ORDERS AND CONSTRUCTION CHANGE DIRECTIVES FOR THE NEW MINDEN HIGH SCHOOL BUILDING PROJECT

**Minden Public School District
Meeting of Board of Education, September 12, 2016**

MOTION by _____, that the Board of Education of this School District should, and does hereby, ratify the change orders and construction change directives for the new Minden High School building project approved pursuant to the Minden Public Schools – Board of Education Protocol Re: 2014 Bond Issue Projects – Construction Change Orders ad Construction Change Directives (Protocol) listed on PCO #013 attached hereto, having a total cost of \$ _____, and further, upon such ratification, hereby renews and confirms the authority of the Superintendent of Schools under the Protocol to approve change orders and construction change directives up to the dollar amounts set forth in the Protocol.

The foregoing Motion having been read in its entirety, Member _____ seconded the same. After discussion and on roll call vote, the following members voted in favor of passage and adoption of the above Motion and Resolution: _____

_____.
The following members voted against the same: _____.

The following members were absent or not voting: _____.

The above Motion and Resolution, having been consented to by more than a majority of the members of the School Board of this School District, was declared as passed and adopted by the President at a duly held and lawfully convened meeting in full compliance with the Nebraska Open Meetings Law.

DATED this 12th day of September, 2016.

KEARNEY COUNTY SCHOOL DISTRICT 50-0503, A/K/A MINDEN PUBLIC SCHOOL DISTRICT

BY: _____
President