

**NOTICE OF FACILITIES COMMITTEE MEETING  
GALVESTON COMMUNITY COLLEGE DISTRICT  
BOARD OF REGENTS**

In compliance with the Open Meetings Act, Texas Government Code, Section 551.041, notice is hereby given that a Facilities Committee Meeting of the Galveston Community College District Board of Regents will be held on **Wednesday, May 8, 2024**, at 4:00 PM in Room M-202, Galveston College, 4015 Avenue Q, Galveston, Texas 77550.

**- AGENDA -**

- I. Call to Order**
- II. Certification of Posting Notice of Facilities Committee Meeting
- III. Consider Approval of Minutes from the March 20, 2024 Meeting *(Action Item)* 2
- IV. Citizens Desiring to Appear Before the Committee on Agenda Items  
*(Please complete a request card prior to the start of the meeting. The Committee Chairperson may limit the time of appearance before the Committee to three minutes.)*
- V. Review and Consider Proposal to Purchase Furniture for the Northen Backfill Renovation Project 4
- VI. Determine Committee Recommendation to the Board of Regents Regarding Approval of Proposal to Purchase Furniture for the Northen Backfill Renovation Project *(Action Item)* 21
- VII. Review and Consider Approval of Request from CenterPoint Energy for an Electric Easement for the Health Sciences Education Center Building Transformer 38
- VIII. Determine Recommendation to the Board of Regents Regarding Approval of Request from CenterPoint Energy for an Electric Easement for the Health Sciences Education Center Building Transformer *(Action Item)* 45
- IX. Discussion and Update on Facilities Projects to Include the Health Sciences Education Center (HSEC), Backfill renovation Project, and Softball Field 52
- X. Adjournment

---

The notice for this meeting was posted on The notice for this meeting was posted on May 3, 2024 in compliance with the Texas Open Meeting Act., in compliance with the Texas Open Meetings Act.

W. Myles Shelton, Ed.D., President

**MINUTES OF THE BOARD OF REGENTS  
FACILITIES COMMITTEE MEETING  
GALVESTON COMMUNITY COLLEGE DISTRICT  
4015 Avenue Q  
Galveston, Texas 77550  
Room M-202 – Moody Hall  
March 20, 2024  
4:30 p.m.**

At the Galveston Community College District Board of Regents Facilities Committee Meeting, duly held on Wednesday, March 20, 2024 in Room M-202 of Moody Hall, commencing at 4:30 p.m., the following Facilities Committee members were present: Mr. Michael B. Hughes, Chairperson, Dr. Norman Hoffman (arrived at 4:52 p.m.), Mr. Raymond Lewis, Jr. (excused), Mr. Fred D. Raschke, Ms. Carolyn L. Sunseri. Other Regents present were: Mr. Garrik Addison, Ms. Karen Flowers, Ms. Mary Longoria., and Mr. Armin Cantini.

Staff present included Dr. W. Myles Shelton, President, Dr. Conrad Breitbach, Ms. Breanne Loreface, Mr. Tracy Morgan, and Dr. Van Patterson.

- I. **CALL TO ORDER:** Chair Hughes opened the meeting at 4:31p.m. in Room M-202 of Moody Hall and determined a quorum was present.
- II. **CERTIFICATION OF POSTING NOTICE OF FACILITIES COMMITTEE MEETING:** Dr. Shelton confirmed that the notice of the Facilities Committee Meeting had been properly posted on March 8, 2024.
- III. **CONSIDER APPROVAL OF MINUTES FROM THE JANUARY 10, 2024 MEETING:** A reading of the minutes for the January 10, 2024 meeting was waived. Mr. Raschke moved to approve the minutes with the correction as presented; Ms. Sunseri seconded. The motion passed unanimously.
- IV. **CITIZENS DESIRING TO APPEAR BEFORE THE COMMITTEE ON AGENDA ITEMS:** There were no citizens present desiring to appear before the Committee.
- V. **CONSTRUCTION UPDATE ON THE HEALTH SCIENCE EDUCATION CENTER (HSEC):** Dr. Shelton presented this item to the Committee. Dr. Shelton provided the Committee with an update on the Health Science Education Center construction, timeline, and budget. General discussion on the timeline and budget was had.
- VI. **DETERMINE COMMITTEE RECOMMENDATION TO THE BOARD OF REGENTS REGARDING THE HEALTH SCIENCE EDUCATION CENTER (HSEC):** There was no recommendation to the Board of Regents.
- VII. **ADJOURNMENT:** There being no further business to come before the Facilities Committee, the meeting adjourned at 5:09 p.m.

---

Breanne Lorefice, Clerk

APPROVED AS CORRECT:

---

Michael B. Hughes, Chairperson

Review and Consider Proposal to Purchase Furniture for the Northern Backfill Renovation Project

Staff requests Board approval to purchase new office, testing center, computer lab and lounge furnishings for the Northern Backfill project. A spec sheet with details on the furniture is attached for your reference.

McCoy Rockford Commercial Interiors (Steelcase E&I CDA # 21Z00987 & Sit On It Omnia Contract #R191803 TVR # 914440), 6869 Old Katy Road, Houston TX 77024 will fill the order, which is priced at \$366,889.82. Funding for this project will come out of the FY25 budget Construction Fund. Proposal available for review upon request.

Following discussion, the Facilities Committee will determine a recommendation to the Board of Regents regarding the proposal to purchase furniture for the Northern Backfill project

# GALVESTON COLLEGE – BACKFILL FURNITURE SPECIFICATIONS

## C.01

STEELCASE | Series 2 Chair

### PART NUMBER

436UPH

### ATTRIBUTES

Upholstered Seat and Back

Plastic Mesh Back Outside Shell

Mid Back

Non-Contrasting Fabric

Armless

Plastic Base and Frame

Hard Casters

### FINISHES

①



Seat/Back  
ArcCom  
Transform  
AC-64145  
Midnight #16

②

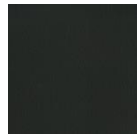

Base/Frame  
Black Plastic



# GALVESTON COLLEGE – BACKFILL FURNITURE SPECIFICATIONS

## C.02

STEELCASE | Amia Work Chair

### PART NUMBER

---

4821410

### ATTRIBUTES

---

Fully Upholstered  
Non-Contrasting Fabric  
H/W/P/D Adjustable Arms  
Plastic Base and Frame  
Hard Casters

### FINISHES

---

①



Seat/Back  
ArcCom  
Transform  
AC-64149  
Stone #20

②

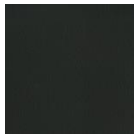

Base/Frame  
Black Plastic



# GALVESTON COLLEGE – BACKFILL FURNITURE SPECIFICATIONS

## C.04

STEELCASE | Move Chair

### PART NUMBER

490410U

### ATTRIBUTES

Upholstered Back and Seat

No Arms

Glides



7

### FINISHES

①



Seat/Back  
ArcCom  
Transform  
AC-64145  
Midnight #16

②



Frame  
Platinum Metallic  
4799

③



Shell Plastic  
Platinum Solid  
6249

11/8/2021

# GALVESTON COLLEGE – BACKFILL FURNITURE SPECIFICATIONS

## L.01

COALESSE | Bob Chair

### PART NUMBER

221

### ATTRIBUTES

34.25"D x 35"W x 41.25"H

High-Back

Fully Upholstered

No Return



8

### FINISHES

①



Upholstery  
ArcCom  
Rodeo AC-69967  
Denim #28

②



Base  
TBD

11/8/2021

MR

# GALVESTON COLLEGE – BACKFILL FURNITURE SPECIFICATIONS

## L.02

COALESSE | Circa Lounge

### PART NUMBER

451-5000

### ATTRIBUTES

28"D x 50"W x 29.5"H x 17.25"SH

Non-contrasting Upholstery

Tapered Wood Legs

Add-on Power Unit Mounted Below Seat



NEMA  
5-20R Outlet

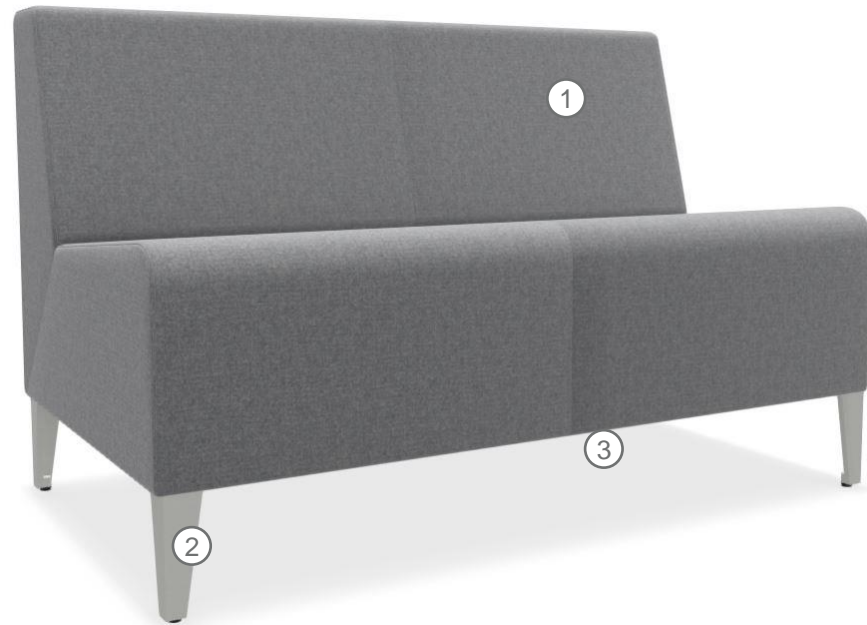

9

### FINISHES

①



Upholstery  
ArcCom  
Rodeo AC-69967  
Denim #28

②

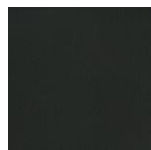

Metal Leg  
4710 Low Gloss  
Black

③



Power Unit

11/8/2021

MR

# GALVESTON COLLEGE – BACKFILL FURNITURE SPECIFICATIONS

## L.05

COALESSE | Joel Lounge

### PART NUMBER

---

COWK100

### ATTRIBUTES

---

29"D x 30.25"W x 27.5"H x 17.5"SH

Fully Upholstered

Swivel Return

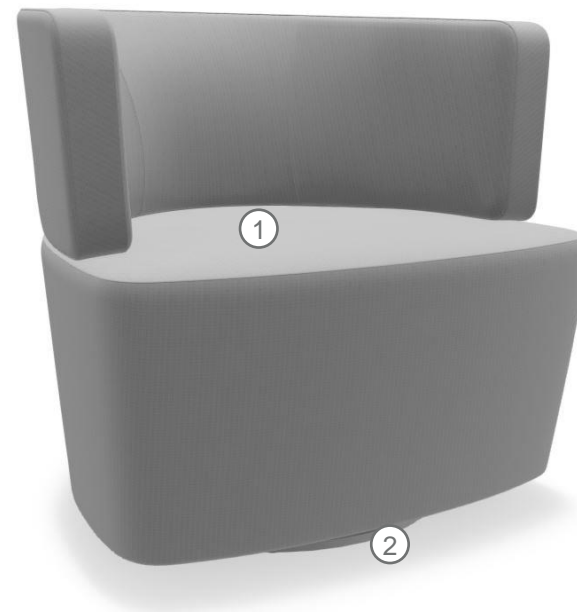

10

### FINISHES

---

①



Upholstery  
ArcCom  
Ambiance AC-63788  
Shark #19

②



Base  
Chrome Plated Steel

11/8/2021

**MR**

# GALVESTON COLLEGE – BACKFILL FURNITURE SPECIFICATIONS

## P.01

STEELCASE | Migration/Currency Office

### PART NUMBER

Build-Up

### ATTRIBUTES

28" x 70" Height Adjustable Laminate  
Desk with Laminate Modesty Panel

24" x 36" Return worksurface with BBF  
Lateral Below

15.75" x 66.5" BF Tower with Wardrobe  
Cabinet

36"W Overhead Storage with Hinged  
Doors

36"W Tackboard and Wall-mounted  
Slatwall with Organizational Worktools

30" x 37" Ceramicsteel Markerboard



11

### FINISHES

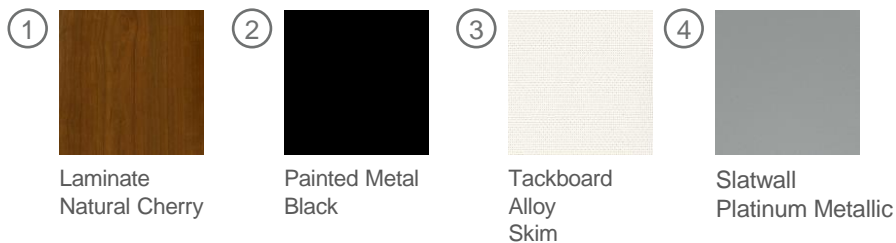

11/8/2021

# GALVESTON COLLEGE – BACKFILL FURNITURE SPECIFICATIONS

## P.02

STEELCASE | Migration/Currency Office

### PART NUMBER

Build-Up

### ATTRIBUTES

36" x 72" Laminate Desk with Recessed Full Modesty and BBF Pedestal

23" x 52" Height Adjustable Laminate Bridge

24" x 60" Credenza Surface with FF Pedestal

15.75" x 66.5" BF Tower with Wardrobe Cabinet

60"W Overhead Storage with Hinged Doors

60"W Tackboard

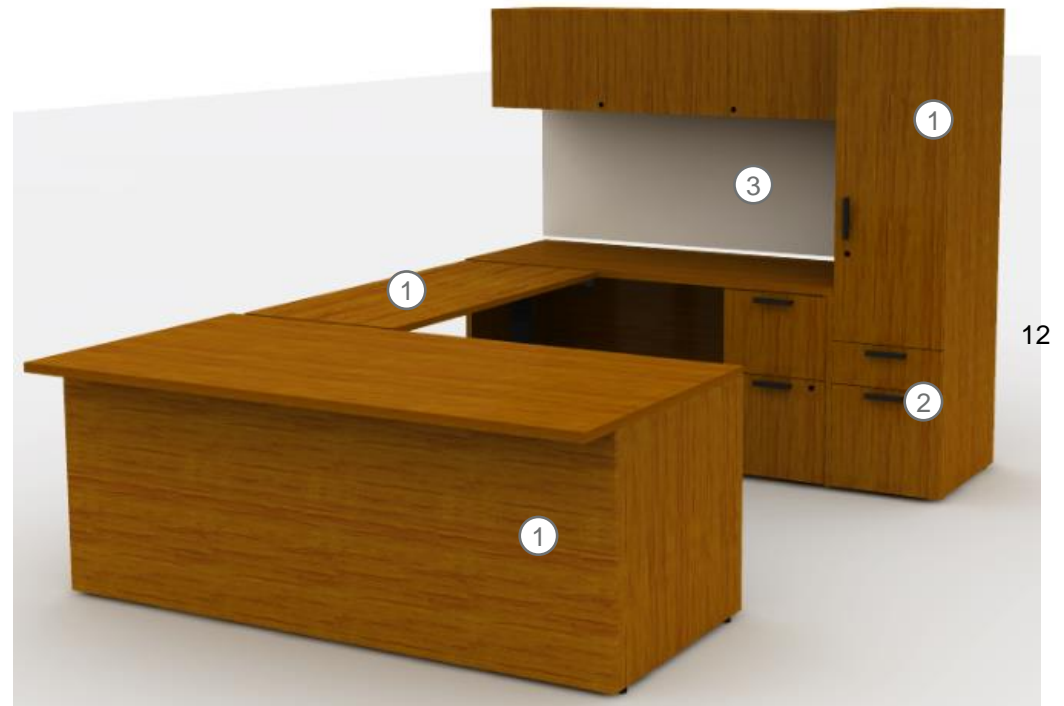

### FINISHES

①

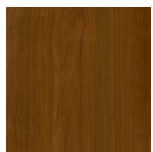

Laminate  
Natural Cherry

②

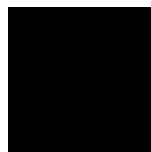

Painted Metal  
Black

③



Tackboard  
Alloy  
Skim

11/8/2021

MR

# GALVESTON COLLEGE – BACKFILL FURNITURE SPECIFICATIONS

## PW.01

STEELCASE | Thread - Hub

### PART NUMBER

PFLHUB

### ATTRIBUTES

37.125”H Worksurface Height

Standard NEMA 3-Prong Plug

6 Outlets

### FINISHES

①

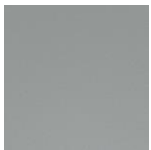

Paint  
Platinum Metallic



# GALVESTON COLLEGE – BACKFILL FURNITURE SPECIFICATIONS

## RD.01

DARRAN | Custom Reception

### PART NUMBER

CUSTOM

### ATTRIBUTES

156"W x 30"D x 29"H (Worksurface) 42"H (Transaction)

Laminate Reception Desk with  
Worksurface Grommets

36"W ADA Pull Up Counter with Modesty

2 BBF Pedestals

Total Qty 2

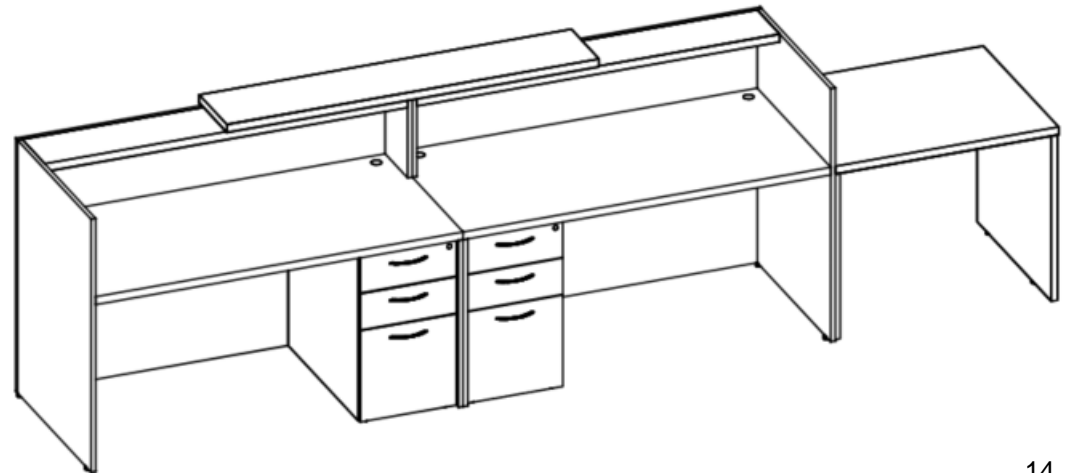

14

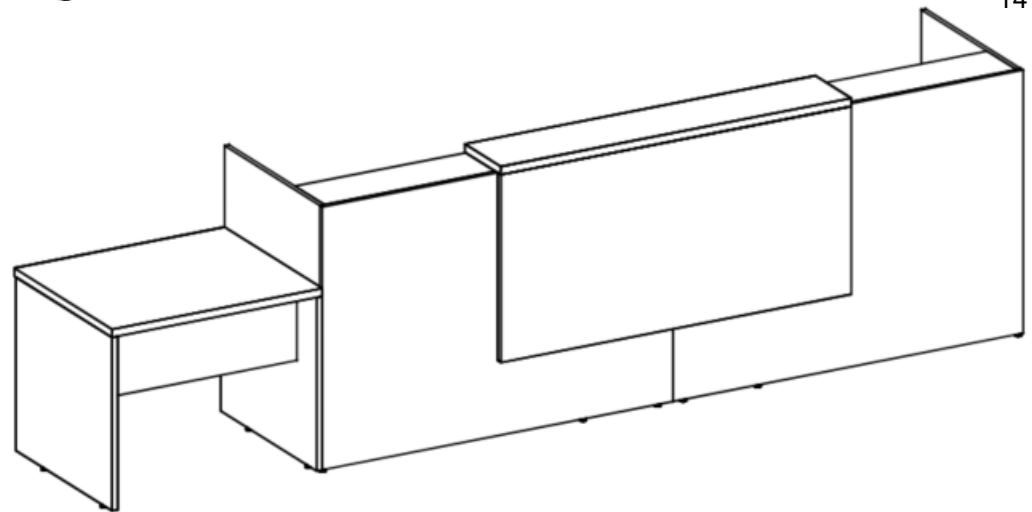

### FINISHES

①



Laminate  
Honey Cherry

②

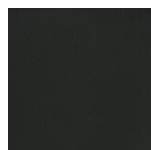

Pulls  
Black

11/8/2021

MR

# GALVESTON COLLEGE – BACKFILL FURNITURE SPECIFICATIONS

## S.01

DARRAN | Buffet Credenza

### PART NUMBER

CPC5824CA126MX1

### ATTRIBUTES

Set of 3 – 58x24x34 Buffet Credenza

Laminate

Storage Cabinets with Drawers Above

15



### FINISHES

①



Laminate  
Honey Cherry

②

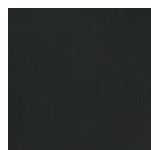

Pulls  
Black

11/8/2021

MR

# GALVESTON COLLEGE – BACKFILL FURNITURE SPECIFICATIONS

## T.01

COALESSE | Circa Table

### PART NUMBER

45-T42RD

### ATTRIBUTES

42" Dia x 15375"H

Laminate Top

Metal Legs

Power Module in Surface



16

### FINISHES

①

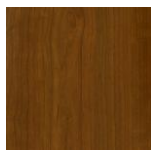

Laminate  
Natural Cherry

②



Painted Metal  
Black

③



Power Unit  
Black



# GALVESTON COLLEGE – BACKFILL FURNITURE SPECIFICATIONS

## T.02

COALESSE | Lagunitas Personal Table

### PART NUMBER

COLAGTP

### ATTRIBUTES

24"W x 13"D x 25"H

Rectangular Laminate Surface

Rounded Edges

Powdercoated Base

4 Non-adjustable Glides



### FINISHES

①

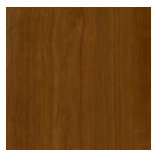

Worksurface  
Natural Cherry

②



Painted Metal  
Black

# GALVESTON COLLEGE – BACKFILL FURNITURE SPECIFICATIONS

## T.03

STEELCASE | Elbrook Group Table

### PART NUMBER

ETGRP

### ATTRIBUTES

72"W x 32"D

Organic Laminate Surface

Powder-coated Legs



18

### FINISHES

①

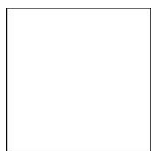

Worksurface  
Arctic White

②



Paint  
Platinum Metallic

11/8/2021

MR

# GALVESTON COLLEGE – BACKFILL FURNITURE SPECIFICATIONS

## T.04

KIMBALL | Height Adjustable Desk

### PART NUMBER

45FTBTSEF9P / AC48WSSR / SS3060WSSL3

### ATTRIBUTES

29x60 Laminate Top with Center Grommet  
Xsede T-Leg Freestanding Adjustable Base  
Undersurface Support Rail  
Vertical Cable Manager

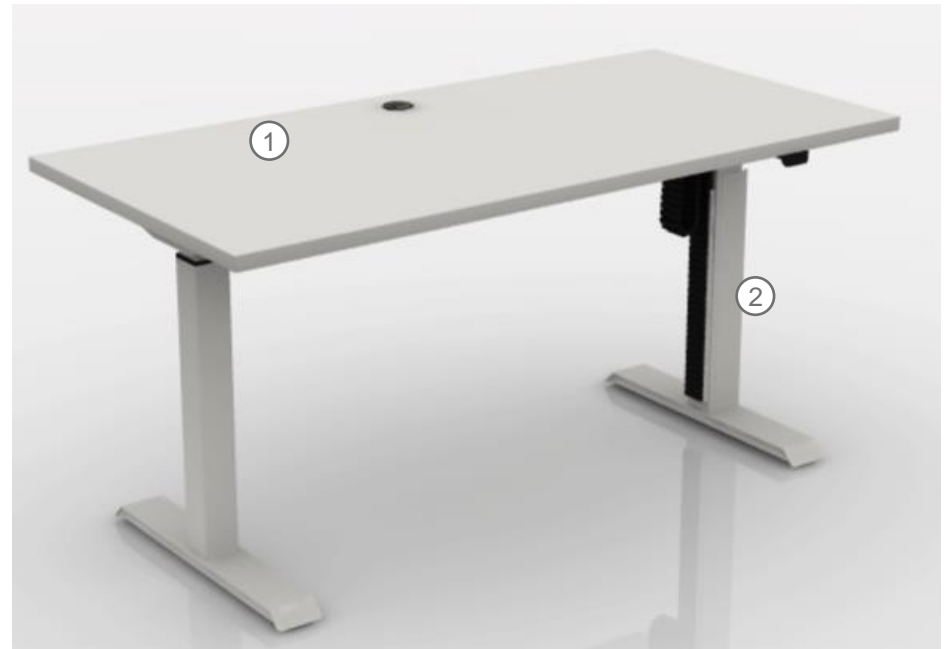

19

### FINISHES

①



Worksurface  
Cloud

②

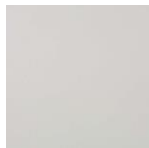

Painted Metal  
Cloud

11/8/2021

**MR**

# GALVESTON COLLEGE – BACKFILL FURNITURE SPECIFICATIONS

## WS.01/WS.02

KIMBALL | Narrate

### PART NUMBER

BUILDUP

### ATTRIBUTES

67.5”H Narrate Panels – Laminate Exterior

42”D Divider panels

30x36 Standard Worksurface

Height Adjustable Desk with H-Leg (1 per Room)

-29x35.5 (N-222 & N-226)

-29x48 (N-228 & N-230)

2 Duplex Receptacles per Station

Open Panel Access for Infeeds

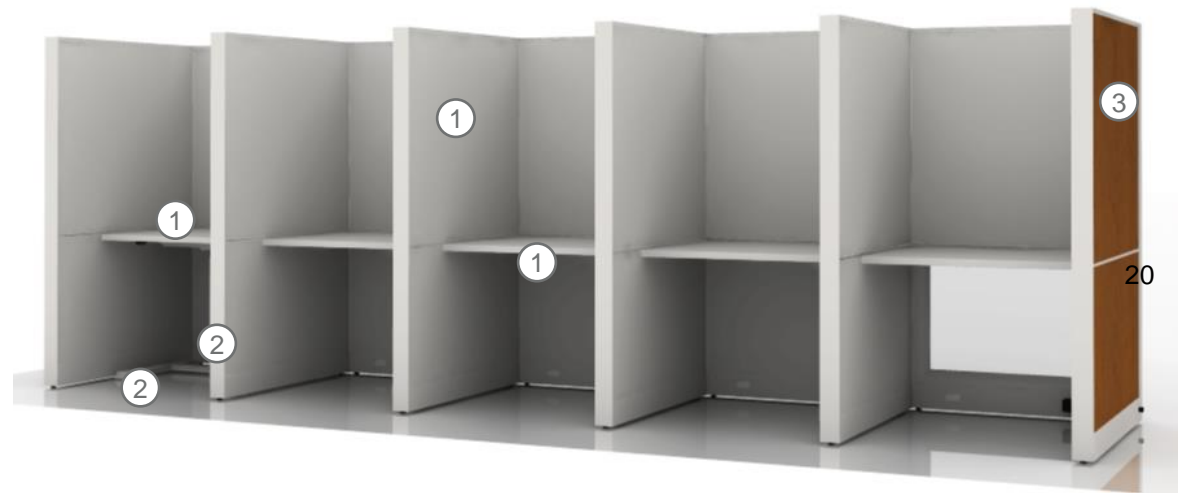

### FINISHES

①



Worksurface/Panel  
Laminate  
Cloud

②

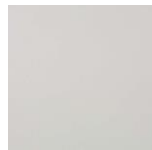

Painted Metals  
Cloud

③



Laminate Skins  
Cordoba

11/8/2021

MR

Review and Consider Proposal to Purchase Furniture for the Northern Backfill Renovation Project

Staff requests Board approval to purchase new office, testing center, computer lab and lounge furnishings for the Northern Backfill project. A spec sheet with details on the furniture is attached for your reference.

McCoy Rockford Commercial Interiors (Steelcase E&I CDA # 21Z00987 & Sit On It Omnia Contract #R191803 TVR # 914440), 6869 Old Katy Road, Houston TX 77024 will fill the order, which is priced at \$366,889.82. Funding for this project will come out of the FY25 budget Construction Fund. Proposal available for review upon request.

Following discussion, the Facilities Committee will determine a recommendation to the Board of Regents regarding the proposal to purchase furniture for the Northern Backfill project

# GALVESTON COLLEGE – BACKFILL FURNITURE SPECIFICATIONS

## C.01

STEELCASE | Series 2 Chair

### PART NUMBER

436UPH

### ATTRIBUTES

Upholstered Seat and Back

Plastic Mesh Back Outside Shell

Mid Back

Non-Contrasting Fabric

Armless

Plastic Base and Frame

Hard Casters

### FINISHES

①



Seat/Back  
ArcCom  
Transform  
AC-64145  
Midnight #16

②



Base/Frame  
Black Plastic



# GALVESTON COLLEGE – BACKFILL FURNITURE SPECIFICATIONS

## C.02

STEELCASE | Amia Work Chair

### PART NUMBER

---

4821410

### ATTRIBUTES

---

Fully Upholstered  
Non-Contrasting Fabric  
H/W/P/D Adjustable Arms  
Plastic Base and Frame  
Hard Casters

### FINISHES

---

①



Seat/Back  
ArcCom  
Transform  
AC-64149  
Stone #20

②

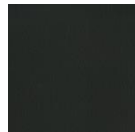

Base/Frame  
Black Plastic



# GALVESTON COLLEGE – BACKFILL FURNITURE SPECIFICATIONS

## C.04

STEELCASE | Move Chair

### PART NUMBER

490410U

### ATTRIBUTES

Upholstered Back and Seat

No Arms

Glides



24

### FINISHES

①



Seat/Back  
ArcCom  
Transform  
AC-64145  
Midnight #16

②



Frame  
Platinum Metallic  
4799

③



Shell Plastic  
Platinum Solid  
6249

# GALVESTON COLLEGE – BACKFILL FURNITURE SPECIFICATIONS

## L.01

COALESSE | Bob Chair

### PART NUMBER

221

### ATTRIBUTES

34.25"D x 35"W x 41.25"H

High-Back

Fully Upholstered

No Return



25

### FINISHES

①



Upholstery  
ArcCom  
Rodeo AC-69967  
Denim #28

②



Base  
TBD

# GALVESTON COLLEGE – BACKFILL FURNITURE SPECIFICATIONS

## L.02

COALESSE | Circa Lounge

### PART NUMBER

451-5000

### ATTRIBUTES

28"D x 50"W x 29.5"H x 17.25"SH

Non-contrasting Upholstery

Tapered Wood Legs

Add-on Power Unit Mounted Below Seat



NEMA  
5-20R Outlet

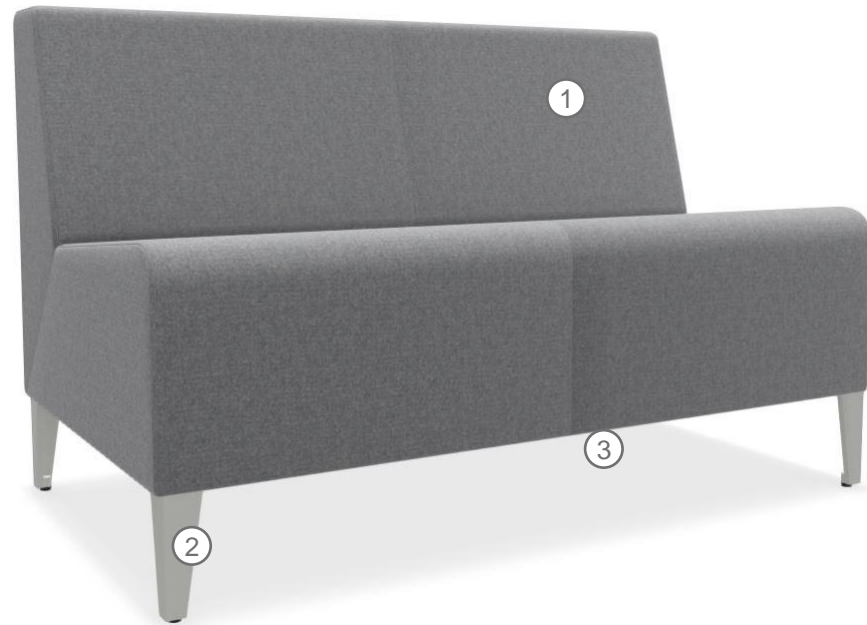

26

### FINISHES

①



Upholstery  
ArcCom  
Rodeo AC-69967  
Denim #28

②

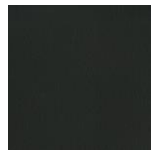

Metal Leg  
4710 Low Gloss  
Black

③



Power Unit

11/8/2021

MR

# GALVESTON COLLEGE – BACKFILL FURNITURE SPECIFICATIONS

## L.05

COALESSE | Joel Lounge

### PART NUMBER

COWK100

### ATTRIBUTES

29"D x 30.25"W x 27.5"H x 17.5"SH

Fully Upholstered

Swivel Return

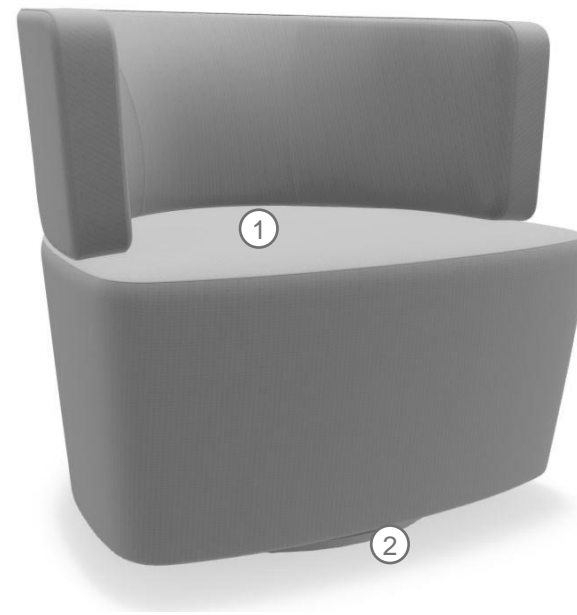

27

### FINISHES

①



Upholstery  
ArcCom  
Ambiance AC-63788  
Shark #19

②



Base  
Chrome Plated Steel

11/8/2021

**MR**

# GALVESTON COLLEGE – BACKFILL FURNITURE SPECIFICATIONS

## P.01

STEELCASE | Migration/Currency Office

### PART NUMBER

Build-Up

### ATTRIBUTES

28" x 70" Height Adjustable Laminate  
Desk with Laminate Modesty Panel

24" x 36" Return worksurface with BBF  
Lateral Below

15.75" x 66.5" BF Tower with Wardrobe  
Cabinet

36"W Overhead Storage with Hinged  
Doors

36"W Tackboard and Wall-mounted  
Slatwall with Organizational Worktools

30" x 37" Ceramicsteel Markerboard



28

### FINISHES

①

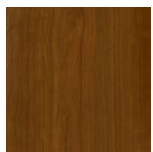

Laminate  
Natural Cherry

②



Painted Metal  
Black

③



Tackboard  
Alloy  
Skim

④



Slatwall  
Platinum Metallic

11/8/2021

MR

# GALVESTON COLLEGE – BACKFILL FURNITURE SPECIFICATIONS

## P.02

STEELCASE | Migration/Currency Office

### PART NUMBER

Build-Up

### ATTRIBUTES

36" x 72" Laminate Desk with Recessed Full Modesty and BBF Pedestal

23" x 52" Height Adjustable Laminate Bridge

24" x 60" Credenza Surface with FF Pedestal

15.75" x 66.5" BF Tower with Wardrobe Cabinet

60"W Overhead Storage with Hinged Doors

60"W Tackboard

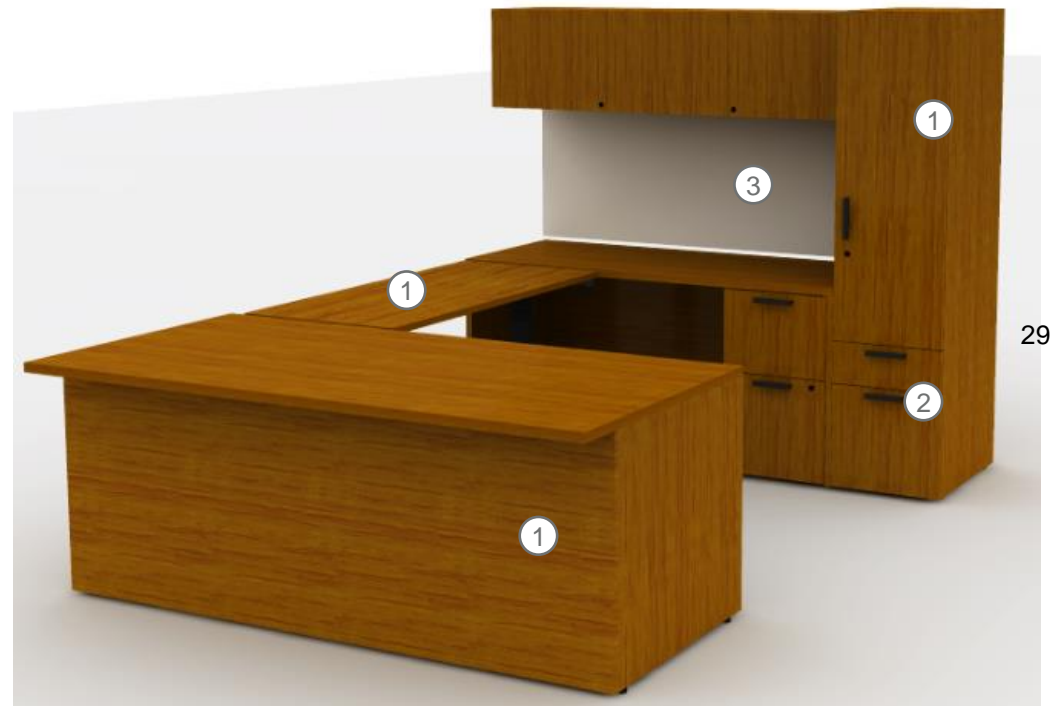

### FINISHES

①

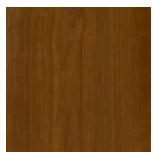

Laminate  
Natural Cherry

②



Painted Metal  
Black

③



Tackboard  
Alloy  
Skim

11/8/2021

MR

# GALVESTON COLLEGE – BACKFILL FURNITURE SPECIFICATIONS

## PW.01

STEELCASE | Thread - Hub

### PART NUMBER

PFLHUB

### ATTRIBUTES

37.125”H Worksurface Height

Standard NEMA 3-Prong Plug

6 Outlets

### FINISHES

①



Paint  
Platinum Metallic



# GALVESTON COLLEGE – BACKFILL FURNITURE SPECIFICATIONS

## RD.01

DARRAN | Custom Reception

### PART NUMBER

CUSTOM

### ATTRIBUTES

156"W x 30"D x 29"H (Worksurface) 42"H (Transaction)

Laminate Reception Desk with  
Worksurface Grommets

36"W ADA Pull Up Counter with Modesty

2 BBF Pedestals

Total Qty 2

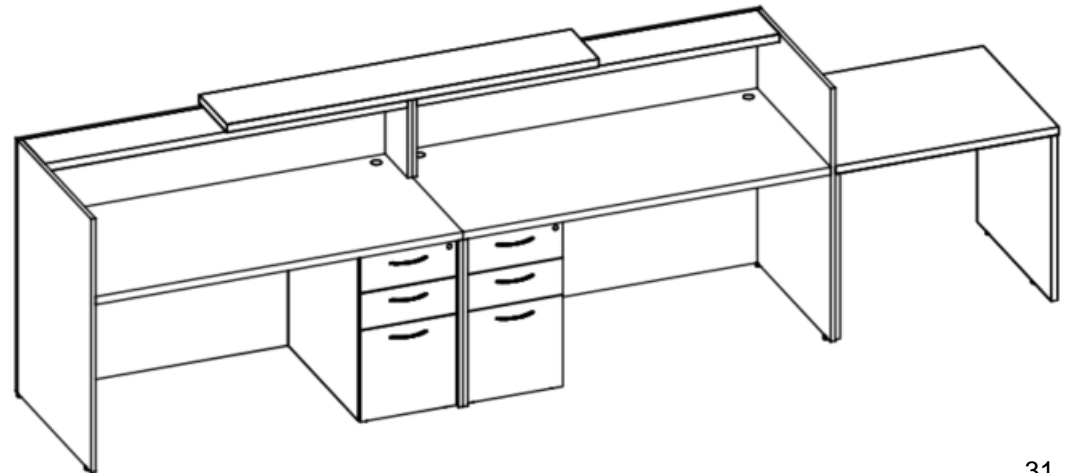

31

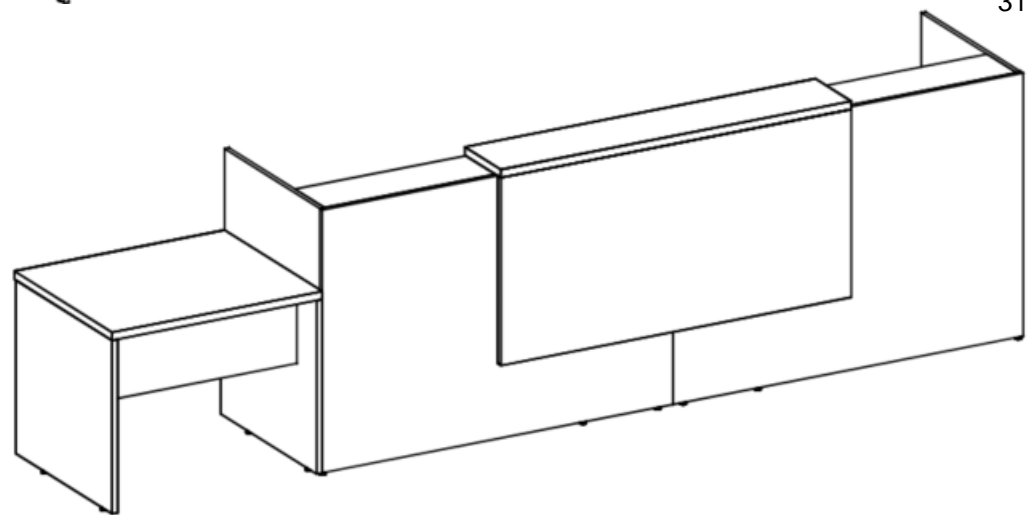

### FINISHES

①



Laminate  
Honey Cherry

②

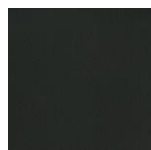

Pulls  
Black

11/8/2021

MR

# GALVESTON COLLEGE – BACKFILL FURNITURE SPECIFICATIONS

## S.01

DARRAN | Buffet Credenza

### PART NUMBER

CPC5824CA126MX1

### ATTRIBUTES

Set of 3 – 58x24x34 Buffet Credenza

Laminate

Storage Cabinets with Drawers Above

32



### FINISHES

①



Laminate  
Honey Cherry

②

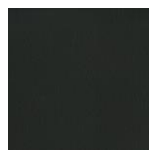

Pulls  
Black

11/8/2021



# GALVESTON COLLEGE – BACKFILL FURNITURE SPECIFICATIONS

## T.01

COALESSE | Circa Table

### PART NUMBER

45-T42RD

### ATTRIBUTES

42" Dia x 15375"H

Laminate Top

Metal Legs

Power Module in Surface



33

### FINISHES

①

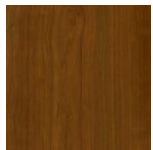

Laminate  
Natural Cherry

②



Painted Metal  
Black

③



Power Unit  
Black



# GALVESTON COLLEGE – BACKFILL FURNITURE SPECIFICATIONS

## T.02

COALESSE | Lagunitas Personal Table

### PART NUMBER

COLAGTP

### ATTRIBUTES

24"W x 13"D x 25"H

Rectangular Laminate Surface

Rounded Edges

Powdercoated Base

4 Non-adjustable Glides



34

### FINISHES

①

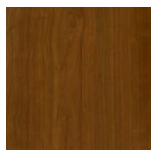

Worksurface  
Natural Cherry

②

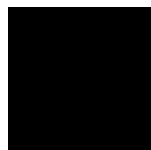

Painted Metal  
Black

11/8/2021

MR

# GALVESTON COLLEGE – BACKFILL FURNITURE SPECIFICATIONS

## T.03

STEELCASE | Elbrook Group Table

### PART NUMBER

---

ETGRP

### ATTRIBUTES

---

72"W x 32"D

Organic Laminate Surface

Powder-coated Legs



35

### FINISHES

---

①

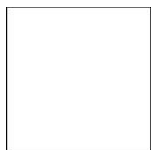

Worksurface  
Arctic White

②



Paint  
Platinum Metallic

11/8/2021

MR

# GALVESTON COLLEGE – BACKFILL FURNITURE SPECIFICATIONS

## T.04

KIMBALL | Height Adjustable Desk

### PART NUMBER

45FTBTSEF9P / AC48WSSR / SS3060WSSL3

### ATTRIBUTES

29x60 Laminate Top with Center Grommet  
Xsede T-Leg Freestanding Adjustable Base  
Undersurface Support Rail  
Vertical Cable Manager

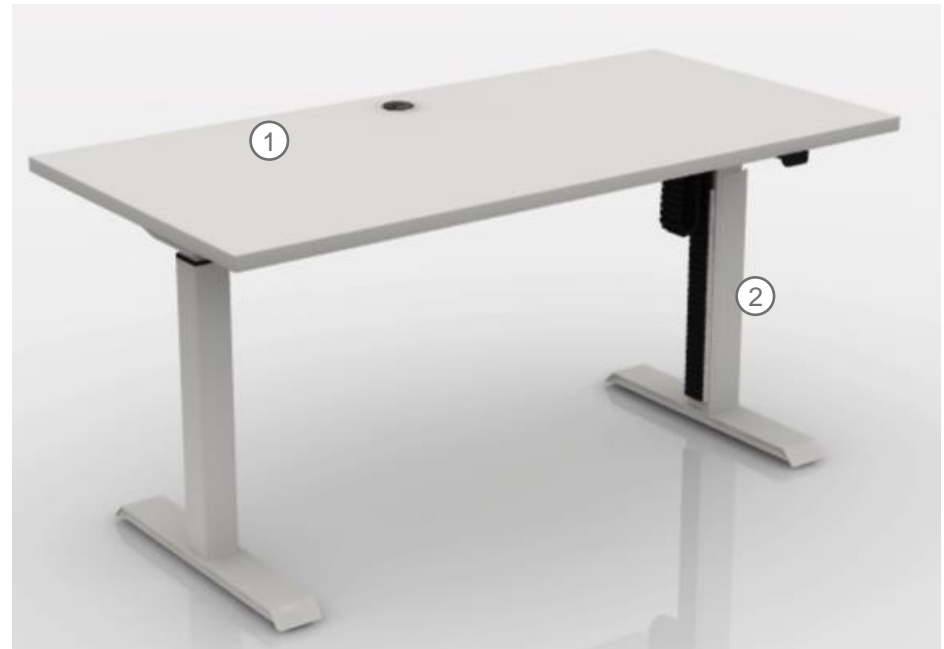

36

### FINISHES

①



Worksurface  
Cloud

②

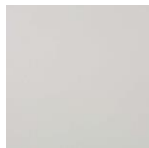

Painted Metal  
Cloud

11/8/2021

**MR**

# GALVESTON COLLEGE – BACKFILL FURNITURE SPECIFICATIONS

## WS.01/WS.02

KIMBALL | Narrate

### PART NUMBER

BUILDUP

### ATTRIBUTES

67.5”H Narrate Panels – Laminate Exterior

42”D Divider panels

30x36 Standard Worksurface

Height Adjustable Desk with H-Leg (1 per Room)

-29x35.5 (N-222 & N-226)

-29x48 (N-228 & N-230)

2 Duplex Receptacles per Station

Open Panel Access for Infeeds

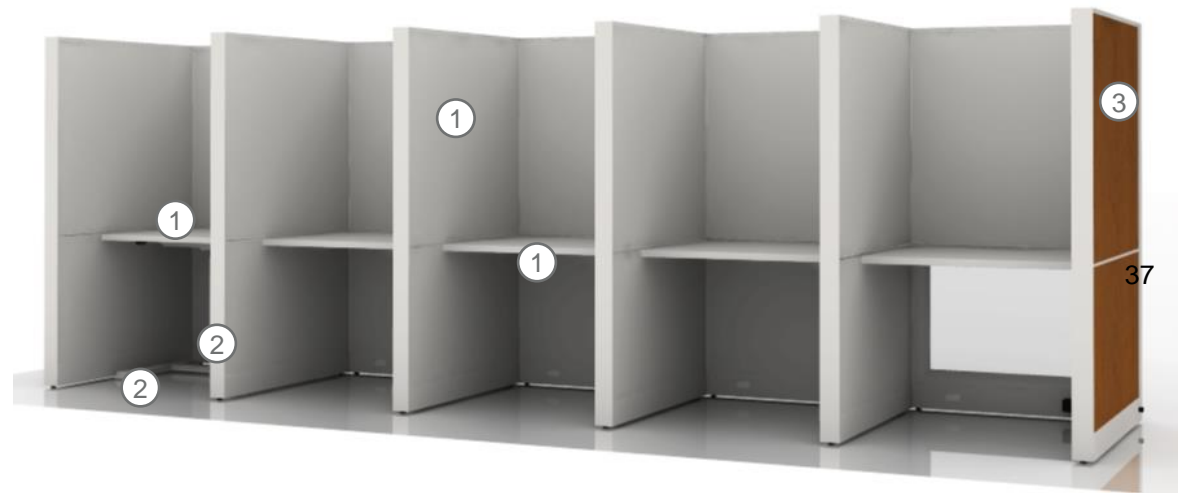

### FINISHES

①



Worksurface/Panel  
Laminate  
Cloud

②

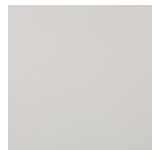

Painted Metals  
Cloud

③



Laminate Skins  
Cordoba

11/8/2021

MR

Review and Consider Approval of Request from CenterPoint Energy for an Electric Easement for the Health Sciences Education Center Building Transformer

CenterPoint Energy Houston Electric, P.O. Box 1700, Houston Texas 77251-1700 is requesting an updated exclusive perpetual easement for electric distribution and related communications facilities consisting of a variable number of wires and cables and all necessary and desirable equipment and appurtenances, including, but not limited to, towers or poles made of wood, metal or other materials, props and guys, located within a portion of the following described lands owned by Galveston College, to wit:

That certain tract of land being the West one-half (1/2) of Outlot 109 and the West 40 feet of the Southeast quarter of Outlot 109 situated in the Michael B. Menard League, Abstract 628, Galveston County, Texas, being the same property described in a deed from St. Mary's Orphan Asylum of Galveston to Galveston Junior College District of Galveston County, Texas, dated July 31, 1967 and filed for record in Volume 1881, Page 395, in the Official Public Records of said County and State.

The unobstructed easement area(s) herein granted, hereinafter referred to as the "Easement Area", whether one or more, are described as follows:

1. An easement sixteen (16) feet wide and twenty-four (24) feet long for Grantee's pad-mounted transformer station, the location of which is shown by the crosshatched area on Plat No. 24-0216, attached hereto and made a part hereof.
2. An easement ten (10) feet wide, the location of the centerline of which is shown by the dot-dash symbol on said attached Plat No. 24- 0216.

Staff is requesting Board approval of CenterPoint's request for a perpetual easement for the transformer it placed to support the Health Sciences Building. This request is more detailed and specific concerning the actual location of the transformer than the "Short Form Blanket Easement 3-Phase Overhead and Underground" approved by the Board on 3/8/23, which allowed CenterPoint to begin to remove and add a power pole and install a transformer to power the new building. Please see Exhibit A – Electric Easement for additional details.

Following discussion, the Facilities Committee will determine a recommendation to the Board of Regents regarding the request from CenterPoint Energy for an electric easement for the Health Sciences Education Center Building Transformer.



The unobstructed easement area(s) herein granted, hereinafter referred to as the "Easement Area", whether one or more, are described as follows:

1. An easement sixteen (16) feet wide and twenty-four (24) feet long for Grantee's pad-mounted transformer station, the location of which is shown by the crosshatched area on Plat No. 24-0216, attached hereto and made a part hereof.
2. An easement ten (10) feet wide, the location of the centerline of which is shown by the dot-dash symbol on said attached Plat No. 24-0216.

Grantor shall observe and exercise all notification laws as per the Underground Facility Damage Prevention and Safety Act, also known as "ONE CALL" & "CALL BEFORE YOU DIG", when working in or near the Easement Area.

To the extent that such laws and codes apply to Grantor, its successors and assigns, Grantor, its successors and assigns shall observe all safety codes and laws which apply to working along, within and/or near the Easement Area and Facilities during construction activities and safe clearance from such Facilities, including the Occupational Safety and Health Administration ("OSHA"), Chapter 752 of the Texas Health and Safety Code ("THSC"), the National Electric Code ("NEC"), and the National Electrical Safety Code ("NESC").

Absent written authorization by the Grantee, all utility and aerial easements must be kept unobstructed from any non-utility improvements or obstructions by Grantor. Any unauthorized improvements or obstructions may be removed by Grantee at the Grantor's expense. While wooden posts and paneled wooden fences along the perimeter and back to back easements and alongside rear lots lines are permitted, they too may be removed by Grantee at the Grantor's expense should they be an obstruction. Grantee may put said wooden posts and paneled wooden fences back up, but generally will not replace them

with new fencing.

Grantee shall not deny or obstruct ingress or egress to or from Grantor's Property, and Grantor retains all rights to cross the Easement Area for access, but not interfering with the utility purpose for which the Easement is granted. Grantor shall have the right to construct or locate in a near perpendicular fashion, utilities, drainage, ditches, roadways, driveways, across, but not along or solely along, within or under the Easement Area herein granted. Grantor assumes all responsibility for the cost of constructing, paving and maintaining said roadways or driveways within easement crossing areas. In the event Grantor constructs, or causes to be constructed, any utilities, drainage, ditches, roadways, and/or driveways which results in the relocation of Grantee's Facilities, the Grantor will be responsible for all costs associated with the relocation and/or removal of Grantee's Facilities. Grantor is prohibited from using the Easement Area for stockpile, spoil, water retention or detention, or lay down areas.

Grantee shall also have reasonable rights of ingress and egress to and from said Easement Area, together with reasonable working space, for the purposes of erecting, installing, operating, maintaining, replacing, inspecting, and removing said Facilities, together with the additional right to remove from said Easement Area and Grantor's Property immediately adjoining thereto, all bushes, trees and parts thereof, or other structures or improvements which are within, protrude, bisect, encroach or overhang into said Easement Area and which, in the sole opinion of Grantee, endanger or may interfere with the efficient, safe and proper operation, and maintenance of said Facilities. Further, in the event dead or dangerous trees exist within the fall range of overhead electrical facilities, then Grantee shall have the right to take down dead or dangerous trees based on Grantee's discretion.

TO HAVE AND TO HOLD the above described Easement, together with all and singular the rights and appurtenances thereto in anywise belonging, unto Grantee, forever, and Grantor does hereby bind itself and its successors, heirs, assigns, and legal representatives, to fully warrant and forever defend all and singular the above described Easement and rights unto said Grantee, against every person whomsoever lawfully claiming or to claim the same or any part thereof, by, through or under Grantor, but not otherwise. In the event of a deficiency in title or actions taken by others which results in the relocation of Grantee's Facilities, the Grantor herein, its successors and assigns, will be responsible for all costs associated with the relocation and/or removal of Grantee's Facilities.

The terms, conditions and provisions contained herein constitute the complete and final agreement between Grantor and Grantee, (collectively the "Parties") with respect to the subject matter hereof and supersedes all prior agreements, representations and understandings of the Parties and, by Grantor's signature affixed hereto and Grantee's use of the Easement, the Parties evidence their agreement thereof. No oral or written agreements made or discussed prior to, or subsequent to, the execution of this Easement shall supersede those contained herein. Any and all revisions, amendments and/or exceptions to the terms, conditions and provisions contained in this Easement shall be in written, recordable form and executed by both parties, or their respective successors or assigns in order to be deemed valid.

EXECUTED this [ ] day of [ ], 20[ ].

GALVESTON JUNIOR COLLEGE DISTRICT OF GALVESTON COUNTY, TEXAS,  
A JUNIOR COLLEGE DISTRICT ORGANIZED UNDER THE LAWS OF TEXAS  
AND USUALLY KNOWN AS GALVESTON COMMUNITY COLLEGE

BY: [ ]  
Signature

[ ]  
Name typed or printed

[ ]  
Title

STATE OF TEXAS }

COUNTY OF [ ] }

BEFORE ME, the undersigned authority, a Notary Public in and for the State of Texas,  
on this day personally appeared [ ],  
[ ] of Galveston Junior College District of Galveston  
County, Texas, a Junior College District organized under the laws of Texas and usually  
known as Galveston Community College, known to me to be the person whose name is  
subscribed to the foregoing instrument and acknowledged to me that ( )he executed the  
same for the purposes and consideration therein expressed, in the capacity therein  
stated, and as the act and deed of said entity.

Given under my hand and seal of office this [ ] day of [ ], 20[ ].

[ ]  
Notary's Signature

[ ]  
Name typed or printed

[ ]  
Commission Expires

**AFTER RECORDING RETURN TO:  
SURVEYING & RIGHT OF WAY  
CENTERPOINT ENERGY HOUSTON ELECTRIC, LLC  
P. O. BOX 1700  
HOUSTON, TX 77251-1700**



**CITY OF GALVESTON**  
**OUTLOT - 109**  
 (UNRECORDED)

**GALVESTON JUNIOR COLLEGE DISTRICT OF GALVESTON COUNTY, TEXAS**  
 WEST ONE-HALF OF OUTLOT 109 AND THE WEST 40 FEET OF SOUTHEAST QUARTER OF OUTLOT 109  
 VOL. 1881 PG. 395 D.R.

**MICHAEL B. MENARD**  
**LEAGUE, A-628**

**GALVESTON COLLEGE ADDITION**  
 LOT 1  
 (CALLED 3.463 AC.)  
 C.C.F. #2018002253 M.R.

THIRTY NINTH STREET (80')

JACK JOHNSON BLVD (80')  
 F.K.A. FORTY FIRST STREET

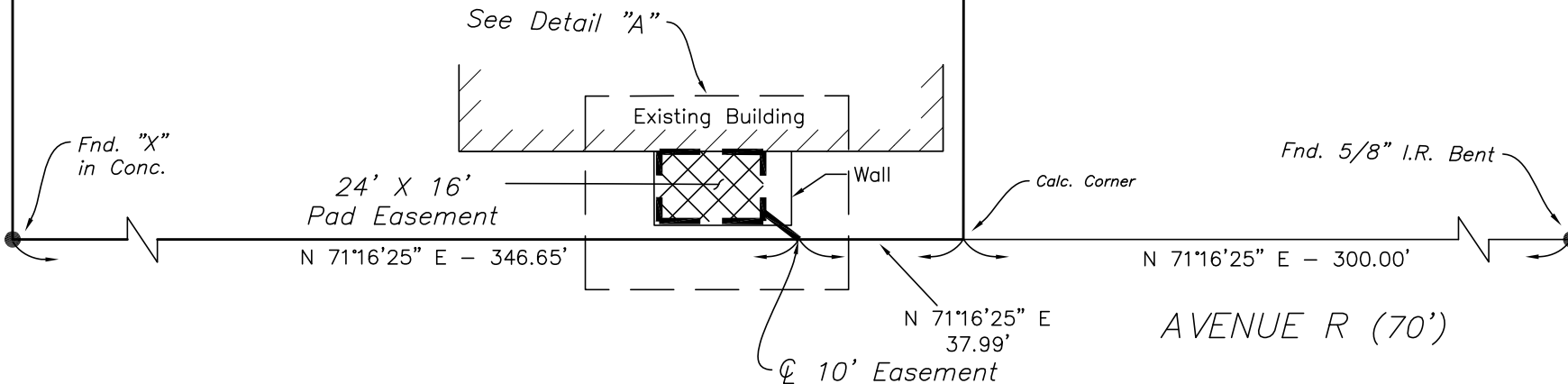

**OUTLOT - 134**

24' X 16'  
 Pad Easement  
 Wall  
 Detail "A"  
 Not to Scale

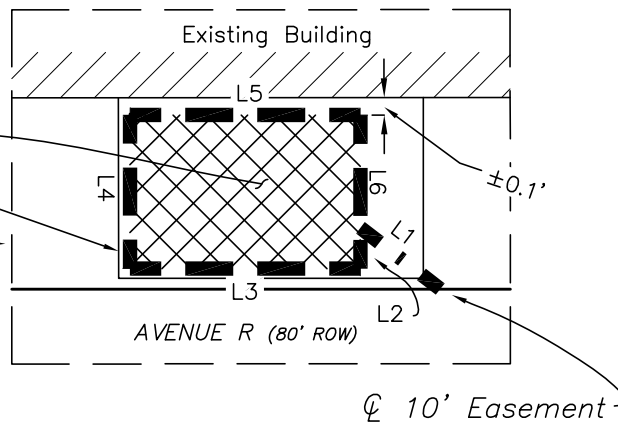

Line Table		
Line #	Length	Direction
L1	10.50'	N 71°19'16" W
L2	2.13'	S 18°41'00" E
L3	24.00'	S 71°19'00" W
L4	16.00'	N 18°41'00" W
L5	24.00'	N 71°19'00" E
L6	13.87'	S 18°41'00" E

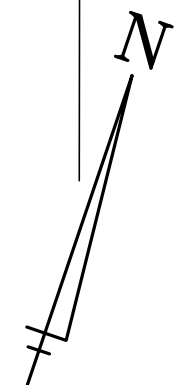

Bearing Basis:  
 Texas Coordinate System of  
 1983, South Central Zone  
 (TXSC Zone 4204); NAD 83

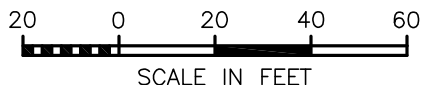

NOTE: THE EXTERIORS OF ALL EASEMENTS ARE TO INTERSECT WITH THE EXTERIORS OF ALL ADJOINING EASEMENTS OR WITH ADJOINING PROPERTY LINES.

REV.1:JOB NO.	BY:	DATE:	REV.2:JOB NO.	BY:	DATE:
EASEMENT - UNOBSTRUCTED					
COUNTY: GALVESTON		LAST PLOT DATE: 4-1-2024			
SURVEY DATE: 3-16-2024		DRAWN BY: J.R.P.			
SCALE: 1" = 40'		MAP4#NO: 6838			
FILE NO. - BOOK: 2022		JOB NO: 104283470A			
		CHECKED BY: A.B.			

**CenterPoint Energy**  
 SURVEYING & RIGHT OF WAY  
 P.O. Box 1700 Houston, TX 77251-1700  
 713-207-2222  
 Firm Number: 10027400  
 PLAT NO. 24-0216

Review and Consider Approval of Request from CenterPoint Energy for an Electric Easement for the Health Sciences Education Center Building Transformer

CenterPoint Energy Houston Electric, P.O. Box 1700, Houston Texas 77251-1700 is requesting an updated exclusive perpetual easement for electric distribution and related communications facilities consisting of a variable number of wires and cables and all necessary and desirable equipment and appurtenances, including, but not limited to, towers or poles made of wood, metal or other materials, props and guys, located within a portion of the following described lands owned by Galveston College, to wit:

That certain tract of land being the West one-half (1/2) of Outlot 109 and the West 40 feet of the Southeast quarter of Outlot 109 situated in the Michael B. Menard League, Abstract 628, Galveston County, Texas, being the same property described in a deed from St. Mary's Orphan Asylum of Galveston to Galveston Junior College District of Galveston County, Texas, dated July 31, 1967 and filed for record in Volume 1881, Page 395, in the Official Public Records of said County and State.

The unobstructed easement area(s) herein granted, hereinafter referred to as the "Easement Area", whether one or more, are described as follows:

1. An easement sixteen (16) feet wide and twenty-four (24) feet long for Grantee's pad-mounted transformer station, the location of which is shown by the crosshatched area on Plat No. 24-0216, attached hereto and made a part hereof.
2. An easement ten (10) feet wide, the location of the centerline of which is shown by the dot-dash symbol on said attached Plat No. 24- 0216.

Staff is requesting Board approval of CenterPoint's request for a perpetual easement for the transformer it placed to support the Health Sciences Building. This request is more detailed and specific concerning the actual location of the transformer than the "Short Form Blanket Easement 3-Phase Overhead and Underground" approved by the Board on 3/8/23, which allowed CenterPoint to begin to remove and add a power pole and install a transformer to power the new building. Please see Exhibit A – Electric Easement for additional details.

Following discussion, the Facilities Committee will determine a recommendation to the Board of Regents regarding the request from CenterPoint Energy for an electric easement for the Health Sciences Education Center Building Transformer.



The unobstructed easement area(s) herein granted, hereinafter referred to as the "Easement Area", whether one or more, are described as follows:

1. An easement sixteen (16) feet wide and twenty-four (24) feet long for Grantee's pad-mounted transformer station, the location of which is shown by the crosshatched area on Plat No. 24-0216, attached hereto and made a part hereof.
2. An easement ten (10) feet wide, the location of the centerline of which is shown by the dot-dash symbol on said attached Plat No. 24-0216.

Grantor shall observe and exercise all notification laws as per the Underground Facility Damage Prevention and Safety Act, also known as "ONE CALL" & "CALL BEFORE YOU DIG", when working in or near the Easement Area.

To the extent that such laws and codes apply to Grantor, its successors and assigns, Grantor, its successors and assigns shall observe all safety codes and laws which apply to working along, within and/or near the Easement Area and Facilities during construction activities and safe clearance from such Facilities, including the Occupational Safety and Health Administration ("OSHA"), Chapter 752 of the Texas Health and Safety Code ("THSC"), the National Electric Code ("NEC"), and the National Electrical Safety Code ("NESC").

Absent written authorization by the Grantee, all utility and aerial easements must be kept unobstructed from any non-utility improvements or obstructions by Grantor. Any unauthorized improvements or obstructions may be removed by Grantee at the Grantor's expense. While wooden posts and paneled wooden fences along the perimeter and back to back easements and alongside rear lots lines are permitted, they too may be removed by Grantee at the Grantor's expense should they be an obstruction. Grantee may put said wooden posts and paneled wooden fences back up, but generally will not replace them

with new fencing.

Grantee shall not deny or obstruct ingress or egress to or from Grantor's Property, and Grantor retains all rights to cross the Easement Area for access, but not interfering with the utility purpose for which the Easement is granted. Grantor shall have the right to construct or locate in a near perpendicular fashion, utilities, drainage, ditches, roadways, driveways, across, but not along or solely along, within or under the Easement Area herein granted. Grantor assumes all responsibility for the cost of constructing, paving and maintaining said roadways or driveways within easement crossing areas. In the event Grantor constructs, or causes to be constructed, any utilities, drainage, ditches, roadways, and/or driveways which results in the relocation of Grantee's Facilities, the Grantor will be responsible for all costs associated with the relocation and/or removal of Grantee's Facilities. Grantor is prohibited from using the Easement Area for stockpile, spoil, water retention or detention, or lay down areas.

Grantee shall also have reasonable rights of ingress and egress to and from said Easement Area, together with reasonable working space, for the purposes of erecting, installing, operating, maintaining, replacing, inspecting, and removing said Facilities, together with the additional right to remove from said Easement Area and Grantor's Property immediately adjoining thereto, all bushes, trees and parts thereof, or other structures or improvements which are within, protrude, bisect, encroach or overhang into said Easement Area and which, in the sole opinion of Grantee, endanger or may interfere with the efficient, safe and proper operation, and maintenance of said Facilities. Further, in the event dead or dangerous trees exist within the fall range of overhead electrical facilities, then Grantee shall have the right to take down dead or dangerous trees based on Grantee's discretion.

TO HAVE AND TO HOLD the above described Easement, together with all and singular the rights and appurtenances thereto in anywise belonging, unto Grantee, forever, and Grantor does hereby bind itself and its successors, heirs, assigns, and legal representatives, to fully warrant and forever defend all and singular the above described Easement and rights unto said Grantee, against every person whomsoever lawfully claiming or to claim the same or any part thereof, by, through or under Grantor, but not otherwise. In the event of a deficiency in title or actions taken by others which results in the relocation of Grantee's Facilities, the Grantor herein, its successors and assigns, will be responsible for all costs associated with the relocation and/or removal of Grantee's Facilities.

The terms, conditions and provisions contained herein constitute the complete and final agreement between Grantor and Grantee, (collectively the "Parties") with respect to the subject matter hereof and supersedes all prior agreements, representations and understandings of the Parties and, by Grantor's signature affixed hereto and Grantee's use of the Easement, the Parties evidence their agreement thereof. No oral or written agreements made or discussed prior to, or subsequent to, the execution of this Easement shall supersede those contained herein. Any and all revisions, amendments and/or exceptions to the terms, conditions and provisions contained in this Easement shall be in written, recordable form and executed by both parties, or their respective successors or assigns in order to be deemed valid.

EXECUTED this [ ] day of [ ], 20[ ].

GALVESTON JUNIOR COLLEGE DISTRICT OF GALVESTON COUNTY, TEXAS,  
A JUNIOR COLLEGE DISTRICT ORGANIZED UNDER THE LAWS OF TEXAS  
AND USUALLY KNOWN AS GALVESTON COMMUNITY COLLEGE

BY: [ ]  
Signature

[ ]  
Name typed or printed

[ ]  
Title

STATE OF TEXAS }

COUNTY OF [ ] }

BEFORE ME, the undersigned authority, a Notary Public in and for the State of Texas,  
on this day personally appeared [ ],  
[ ] of Galveston Junior College District of Galveston  
County, Texas, a Junior College District organized under the laws of Texas and usually  
known as Galveston Community College, known to me to be the person whose name is  
subscribed to the foregoing instrument and acknowledged to me that ( )he executed the  
same for the purposes and consideration therein expressed, in the capacity therein  
stated, and as the act and deed of said entity.

Given under my hand and seal of office this [ ] day of [ ], 20[ ].

[ ]  
Notary's Signature

[ ]  
Name typed or printed

[ ]  
Commission Expires

**AFTER RECORDING RETURN TO:  
SURVEYING & RIGHT OF WAY  
CENTERPOINT ENERGY HOUSTON ELECTRIC, LLC  
P. O. BOX 1700  
HOUSTON, TX 77251-1700**



**CITY OF GALVESTON**  
**OUTLOT - 109**  
 (UNRECORDED)

**GALVESTON JUNIOR COLLEGE DISTRICT OF GALVESTON COUNTY, TEXAS**  
 WEST ONE-HALF OF OUTLOT 109 AND THE WEST 40 FEET OF SOUTHEAST QUARTER OF OUTLOT 109  
 VOL. 1881 PG. 395 D.R.

**MICHAEL B. MENARD**  
**LEAGUE, A-628**

**GALVESTON COLLEGE**  
**ADDITION**  
 LOT 1  
 (CALLED 3.463 AC.)  
 C.C.F. #2018002253 M.R.

THIRTY NINTH STREET (80')

JACK JOHNSON BLVD (80')  
 F.K.A. FORTY FIRST STREET

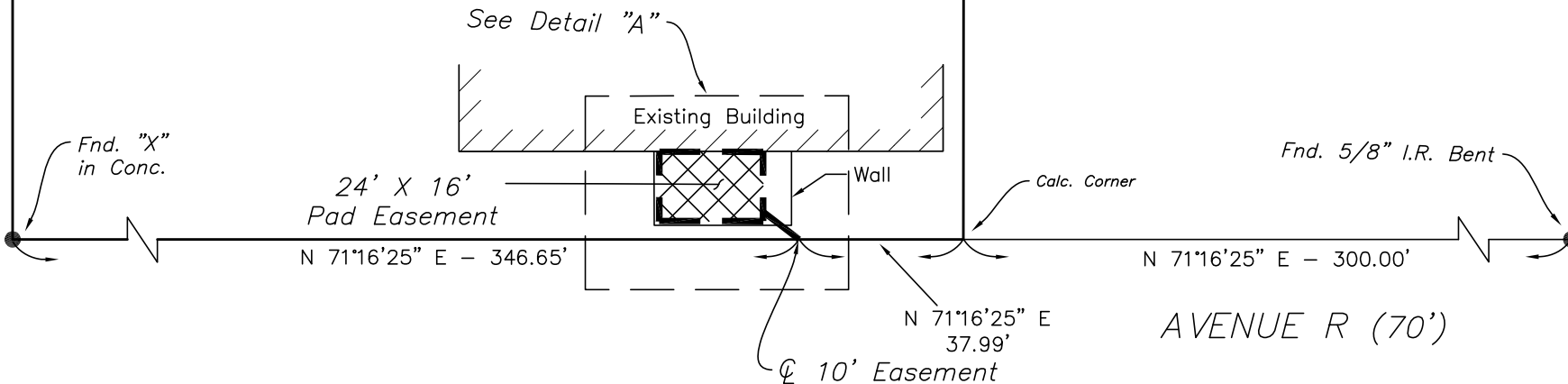

**OUTLOT - 134**

24' X 16'  
 Pad Easement  
 Wall  
 Detail "A"  
 Not to Scale

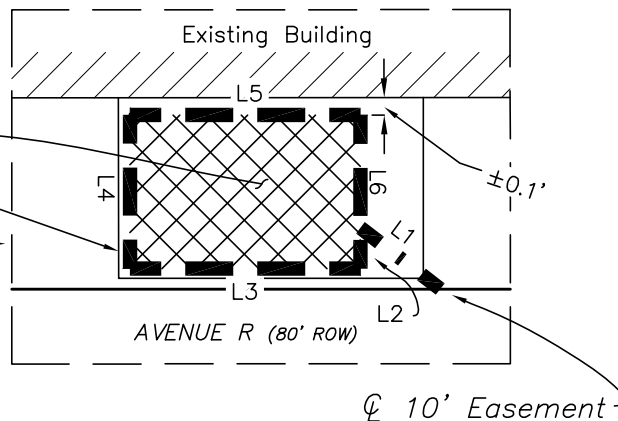

Line Table		
Line #	Length	Direction
L1	10.50'	N 71°19'16" W
L2	2.13'	S 18°41'00" E
L3	24.00'	S 71°19'00" W
L4	16.00'	N 18°41'00" W
L5	24.00'	N 71°19'00" E
L6	13.87'	S 18°41'00" E

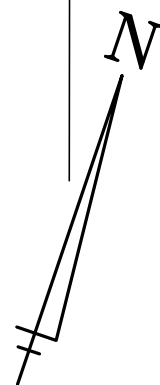

Bearing Basis:  
 Texas Coordinate System of  
 1983, South Central Zone  
 (TXSC Zone 4204); NAD 83

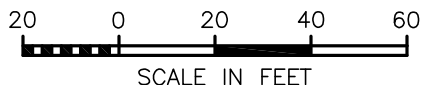

NOTE: THE EXTERIORS OF ALL EASEMENTS ARE TO INTERSECT WITH THE EXTERIORS OF ALL ADJOINING EASEMENTS OR WITH ADJOINING PROPERTY LINES.

REV.1:JOB NO.	BY:	DATE:	REV.2:JOB NO.	BY:	DATE:
EASEMENT - UNOBSTRUCTED					
COUNTY: GALVESTON		LAST PLOT DATE: 4-1-2024			
SURVEY DATE: 3-16-2024		DRAWN BY: J.R.P.			
SCALE: 1" = 40'		MAP5 NO: 6838			
FILE NO. - BOOK: 2022		JOB NO: 104283470A			
		CHECKED BY: A.B.			

**CenterPoint Energy**  
 SURVEYING & RIGHT OF WAY  
 P.O. Box 1700 Houston, TX 77251-1700  
 713-207-2222  
 Firm Number: 10027400  
 PLAT NO. 24-0216

Discussion and Update on Facilities Projects to Include the Health Science Education Center (HSEC), Backfill Renovation Project, and Softball Field

Dr. Shelton will provide an update on facilities projects, to include the Health Science Education Center (HSEC), the backfill renovation project, and the softball field.