



**MINOOKA COMMUNITY HIGH SCHOOL DISTRICT #111  
REGULAR BOARD MEETING  
WEDNESDAY, APRIL 17, 2024, 6:00 PM**

The Regular Board Meeting will be held at the  
Central Campus Library  
301 South Wabena Avenue  
Minooka, Illinois 60447

In order to make a public comment, please sign up 5 minutes prior to Roll Call. The public comment portion of the meeting will be in accordance with Policy 2:230. Please review said policy prior to the Board of Education Meeting. To view the meeting via YouTube, click [here](#).

**AGENDA**

1. **Call to Order**
2. **Roll Call**
3. **Pledge of Allegiance**
4. **Communications / Recognition**
  - **Technology Student Association (TSA) at State** – Justin Blackwell, Nathan Garbrecht, An Nguyen, Ayden Hollingsworth, Owen Kopecky, Ethan Minch, Jaisin Ramirez, Taylor Rodriguez, Kadence Range, Caelan Siebert, Kara Stodter, Emma Bozinovich, William Dykstra, Oliver Feltz, Brooklyn Hedberg, Aidan Jacques, Hudson Westlake
  - **Program of Excellence by the NHSSCA (National High School Strength & Conditioning Association)** - Nick Micetich
5. **Public Comments** - (Per Board Policy 2:230, comments shall be limited to 5 minutes.)
6. **Administrative Reports**

A. Superintendent	4
B. Principal	5
C. Assistant Superintendent of Business	6
D. Director of Curriculum & Instruction	19
E. Director of Community Relations	20
7. **Consent Agenda**

A. Approval of Open Session Minutes	23
B. Approval of Financial Reports	
1. Monthly Financial Report	35
2. Payment of Bills/Total	46
3. Employee Payroll	144
4. Imprest Fund Report/Total	145
5. Activity Fund Report	146
6. Treasurer's Report (Cash/YTD - Exp/Rev)	150

## 8. Committee Reports

265

- Buildings & Grounds (Mr. Shepard) - April 10, 2024 - Construction Meeting Minutes for April 9 and April 16, 2024 - Attached
- Co-Curricular (Mr. Spivey) -
- Curricular - (Mr. Grzetich) -
- Finance (Mrs. Hrechko) - April 10,2024
- Personnel (Mr. Brozovich) - April 10,2024
- Policy (Mr. Juskiewicz) - April 10, 2024
- Special Education (Mr. Hoyt) -
- Technology (Mr. Spivey) -
- Transportation (Mr. Juskiewicz) -
- GAVC (Mrs. Hrechko) - March 21, 2024
- GCSEC (Mr. Hoyt) - April 17, 2024
- Equity and Diversity (Mr. Brozovich) -

## 9. Discussion Items

- |   |     |
|---|-----|
| A. Educational Foundation Update        | 286 |
| B. Facilities Plan                      | 287 |
| C. Cooling Tower - Request for Proposal | 303 |
| D. Furniture - Central Campus Remodel   | 360 |
| E. Yearbook Contract                    | 363 |

## 10. Action Items

- |  |     |
|--|-----|
| A. Consideration and Possible Approval and Adoption of the Handbook Revision as presented.   | 367 |
| B. Consideration and Possible Approval to Award the Water Cooling Tower Bid Repair to Depue Mechanical Inc. in the amount of \$382,768 dollars as presented, subject to attorney review. | 370 |
| C. Consideration and Possible Approval of the Asbestos Abatement Agreements in the total amount of \$26,464 dollars as presented.  | 392 |
| D. Consideration and Possible Approval of the Furniture Purchase for the Central Campus Remodel with Frank Cooney Company in the total amount of \$65,120.60 as presented.               |     |
| E. Consideration and Possible Approval to Purchase 219 Band and 6 Drum Major Full Uniforms with Apollos, Plumes and Shipping in the total amount of \$122,400 dollars as presented.      | 405 |
| F. Consideration and Possible Approval of the Three-year Agreement with Varsity Yearbook in the amount of \$44,803.66 and for Supplement in the amount of \$5,295 dollars as presented.  |     |

11. **Executive Session** - To adjourn the meeting to executive session for discussion on matters related to minutes; the appointment, compensation, discipline, dismissal,

employment and performance of specific employees of the District; student discipline; litigation and collective bargaining.

**12. Action Items Following Executive Session**

- A. Consideration and Possible Approval of Closed Session Minutes
- B. Consideration and Possible Acceptance of Resignation(s)
- C. Consideration and Possible Approval of Paid/Unpaid Leave Request(s)
- D. Consideration and Possible Approval of Employment
- E. Consideration and Possible Approval of Volunteers
- F. Consideration and Possible Approval of Returning Coaches/Sponsors for the 2024/2025 School Year as presented
- G. Consideration and Possible Approval of 2-Year Contract Extensions as presented

**13. Announcements and Communications**

**14. Adjourn**

**Superintendent Report  
BOE Meeting  
4/17/2024**

**HB 5617 Update**

HB 5617 did not clear the committee action April 5 deadline. The sponsor of the bill could ask for an extension or there is a possibility that it could emerge on a shell bill at a later date. As for right now, this is a win for the Minooka Indians. I will continue to work with our legislators on this topic.

**State of the Villages**

I was able to attend the Channahon and Shorewood state of the village events. I will be attending the Minooka event on April 18, 2024. These are great events to hear about the great things that are happening in the communities MCHS serves. MCHS is very lucky to have such great partners.

**Facilities Committee Meeting**

On April 10, 2024 a joint facilities committee was held at the Central Campus. Representatives from DLA presented the conceptual plans for capital improvements at the South Campus and at the Central Campus. Committee members were given the opportunity to ask questions and talk with the representatives from DLA. This meeting was very well attended. It was a great opportunity to discuss the future of MCHS.

**FIOA Requests**

Michelle Kokalj- Requested the driver pay records of routes to Parkland Academy and Core Academy.



# MINOOKA

## COMMUNITY HIGH SCHOOL

District #111 mchs.net

*Mission: Strengthen **M**astery, **C**ollaboration, **H**igh Expectations, and **S**uccess for All Students.*

---

To: Dr. Robert Schiffbauer, Board of Education

From: Jamie Soliman

Date: April 17, 2024

Subject: April Board Report

**MCHS, You! We have a lot of great things going on around MCHS. I wanted to take this opportunity to share accomplishments, and to look ahead to end of year events and celebrations.**

- ★ March 19th we honored our **Illinois State Scholars** with a breakfast ceremony at Central Campus. To be an Illinois State Scholar, a student must perform in the top one-half of their high school class at the end of the third semester prior to graduation, and/or score at or above the 95th percentile on the ACT or SAT. This year, MCHS presented 61 students as Illinois State Scholars.
- ★ On March 20th, I had the honor to present the \$50,000 **Coady Scholarship** to senior Delaini Majetic. The Coady Scholarship committee members, administration, and Delaini's family gathered that morning to surprise her with the announcement. Delaini plans to attend Florida Atlantic and pursue her goal of becoming a Marine Veterinarian. She is beyond grateful for this opportunity.
- ★ Congratulations to **Matt Marino** who presented at the Illinois Communication and Theatre Association on "Keeping Our Fire Alive – Kickstart Our Hearts: Social Emotional Learning for Educators (Too)." Matt's presentation has now been selected and accepted by the Central States Communication Association!
- ★ Thank you to **Kevin Murphy, John Taylor**, and their team on providing South Campus staff with a relaxing outdoor eating area! To see a picture of the new eating area, click [HERE](#).
- ★ Congratulations to **Kristen North** on leading the **TSA team** to 49 medals at the State competition! This is a record number for TSA. What an outstanding accomplishment!
- ★ Our Strength and conditioning Program has been officially recognized as a Power of Excellence by the NHSSCA. **Nick Micetich**, your hard work is paying off for the students of MCHS! Thank you!
- ★ **Little Lunch Bites Professional Development** is a quick stop during lunch periods for teachers to learn instructional strategies that can be used immediately in their classrooms. This semester, we have provided staff with ten Lunch Bite opportunities. Thank you to **Sharon Richardson, Kristen North, Jamie Fisher, Steve Cerovac, Chris Pressler, Chrissy Burgess, and Hannah Keppner** for presenting to your colleagues!
- ★ **Upcoming events:**
  - ASL National Honor Society Induction - April 16
  - Science National Honor Society Induction - April 18
  - Run for Respect - April 21
  - Illinois Principal Association Student Recognition Breakfast - April 24
  - Prom - April 26
  - Faculty Appreciation Night @ Girls Soccer - April 29
  - Adaptive PE Student, Family, and Leader Banquet - May 1
  - Senior Honors Night - May 8

*John Troy*  
*Assistant Superintendent & General Counsel*

*Board Report*

April 12, 2024

1. **Cooling Tower Replacement Bids** - The district published a bid for the South campus cooling tower replacement and the bid opening was Friday, April 12th. Three contractors provided bids, DePue, Helm, and Core. This is on the agenda for approval at the Board meeting. The bids are provided in your board package and the administration is currently reviewing and will make a recommendation prior to the Board meeting.
2. **Equistar Property Valuation** - I met with our real estate valuation attorney who is assisting us and district 201 on a new valuation agreement with Equistar. The meeting was very productive and we are confident that we can obtain a fair and equitable valuation agreement.
3. **Transportation Negotiations** - The transportation negotiations meeting took place on Tuesday April 9th. The district's negotiation team consists of Dr. Schiffbauer, Kathi Norman, Cathy Haase, and myself. There are 6 drivers on the transportation association team who are represented by IEA UniServe director Christy Hagemaster. The team met for approximately two hours and reviewed ground rules, set future dates, and reviewed the association's first drafts.
4. **School Resource Officer Inter-Governmental Agreement Meeting** - On April 10th we met with Minooka and Channahon police departments to discuss a new intergovernmental agreement. The draft agreement was reviewed and discussed. After revisions the document will be presented to the Board for consideration and approval at the May board meeting.















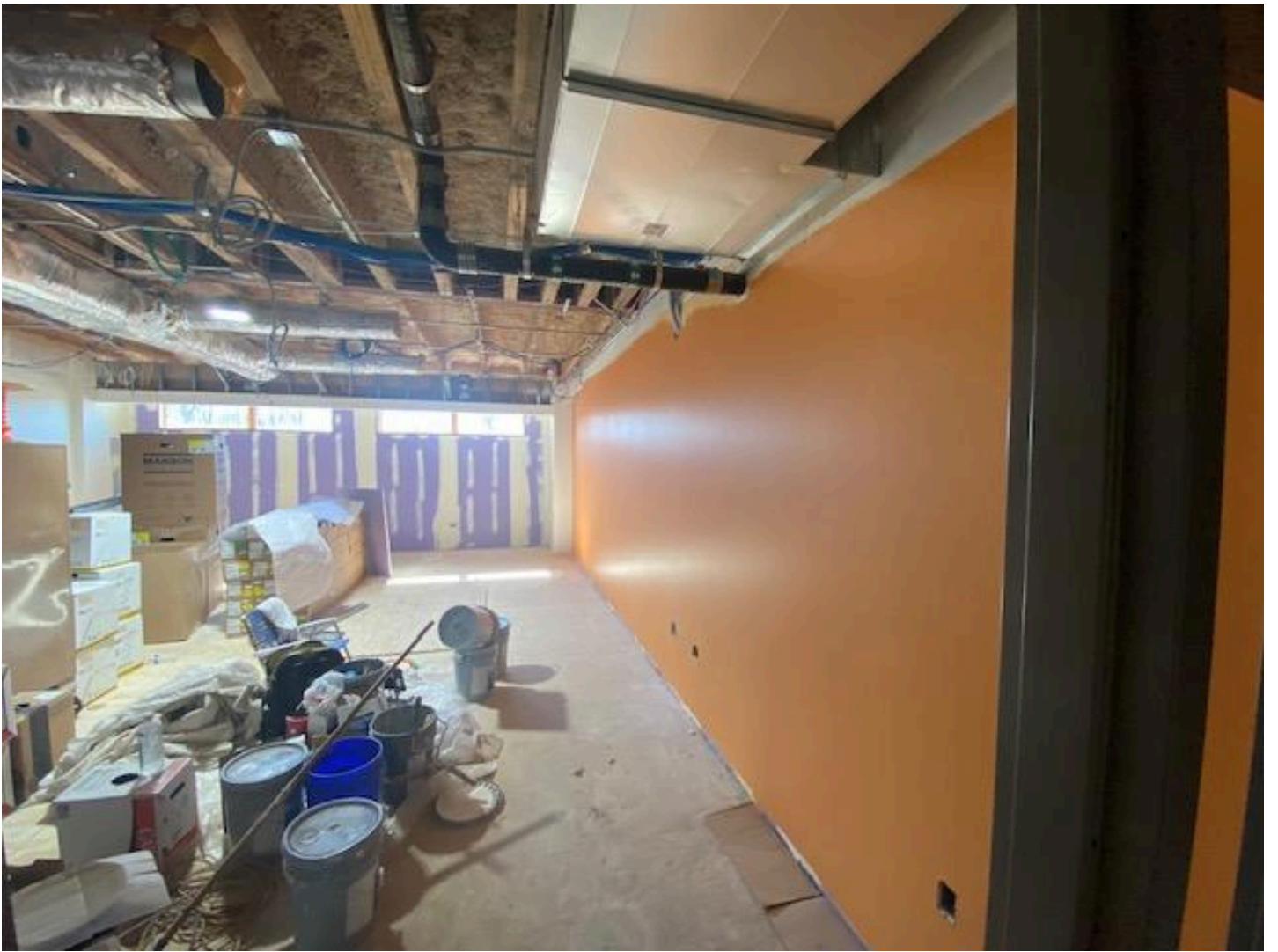











# MINOOKA

## COMMUNITY HIGH SCHOOL

District #111 mchs.net

*Mission: Strengthen **M**astery, **C**ollaboration, **H**igh Expectations, and **S**uccess for All Students.*

---

To: Dr. Robert Schiffbauer, Board of Education

From: Dr. Phil Pakowski

Date: April 17, 2024

Subject: April Board Report

### **Spring Testing Update**

On April 10th all freshman and sophomore students took the PSAT at South Campus while all Juniors took the SAT at Central Campus. A modified testing schedule was run that day and all students were released following the completion of exams. Our staff did an excellent job creating a positive testing environment for all students. A special thank you to Angela Ferro, Jessica Hopkins, Sarah Bonner, Matt Shanahan, Jen Hopman, Katie Engel, and Amy Hocking for coordinating testing for students that day. SAT and PSAT results will be sent to students electronically in May.

The Illinois Science Assessment is currently 80% complete. This test is given to Juniors in the Science classes over a three day period. We will be running a make up session for students that were absent from testing.

The last group of tests for the school year, AP Exams, will begin on May 6th and continue through May 17th. We will have 700 students taking 1700 exams during that two week period.

### **Evaluation Committee**

The evaluation committee will meet in April to review the current evaluation plan and make suggestions for changes to the 2024-2025 evaluation plan. Last year minor changes were suggested to clarify language in the current plan as well as making any changes from the previous year permanent moving forward.

### **Master Schedule Update**

Following the completion of sectioning and staffing meetings the master schedule is currently being developed for the 2024-2025 school year. This process is done electronically and requires several versions to be completed to make sure classes are running at optimal times so students are able to take the courses they have selected and to allow for staff schedule changes to be minimized.



Director of Community Relations Report to the Board of Education  
Aubrey Knight – April 17, 2024

**A. Processed FOIA Requests**

- Michelle Kokalj (received 3/19/24 | responded 3/22/24) “Please provide the pay rates for all 111 bus aides.”
- Michelle Kokalj (received 3/19/24 | responded 3/22/24) “Please provide the rate of reimbursement from the state and/or federal government for individual students (both special ed. and reg. ed.).”
- Jay Jones, SMART Local 265 (received 3/27/24 | extended; responded 4/9/24) “Under the Freedom of Information Act, I’m requesting information for the construction and/or maintenance work planned this year for any building owned or leased by your district which include the scopes listed below. In addition, if any contracts have already been awarded, please include the names, and contact information of those contractor(s) and/or sub-contractor(s). HVAC (Heating, Air Conditioning, Ventilation), Exhaust Systems. Roof work including architectural metals used for weatherproofing and/or ornamental purposes. Gutters and /or Downspouts. New installation and/or replacement of lockers. New installation and/or replacement of toilet partitions. Kitchen Renovations. Current HVAC Maintenance Contracts.”
- Michelle Kokalj (received 4/3/24 | responded 4/9/24) “I am requesting the amount of pay Pam Rabe is getting for her Parkland and Core routes daily.”

**B. Student Celebrations**

- Grundy Area Vocational Center Director Awards – Connor Davis, Cassie Fuhrman, Jesus Rodriguez Angel, Thomas Sullivan, Xavier Taylor
- Rotary Student of the Month – Bailey McIntyre
- Indoor/Outdoor Shot Put School Record – Laila Richardson
- Technology Student Association (TSA) at State – Justin Blackwell, Nathan Garbrecht, An Nguyen, Ayden Hollingsworth, Owen Kopecky, Ethan Minch, Jaisin Ramirez, Taylor Rodriguez, Kadence Range, Caelan Siebert, Kara Stoedter, Emma Bozinovich, William Dykstra, Oliver Feltz, Brooklyn Hedberg, Aidan Jacques, Hudson Westlake

**C. Communication/Social Media**

- **Top Facebook Post:** [Congratulations](#) Congratulations to sophomore Evan Mattison and junior Jack Igric whose 16UAA team won the State Championship for the Chicago Hawks Youth Hockey Club! Best of luck as they travel to Dallas for a shot at the National Title. #mchsproud

- **Top Instagram Post:** [Coady Scholarship](#) Congratulations! A massive and heartfelt congratulations to senior Delaini Majetic for earning the \$50,000 Coady Scholarship, an annual scholarship awarded to a student who demonstrates academic and character traits which indicate the likelihood of continued academic achievement and subsequent contributions to both career and community. We are grateful for this generous donation provided through the Charlene A. Coady Trust. #mchsproud
- **Top Twitter Post:** [Coady Scholarship](#) Congrats to Delaini Majetic for earning the \$50,000 Coady Scholarship that is awarded to a student who demonstrates academic and character traits which indicate the likelihood of continued academic achievement and subsequent contributions to both career and community. #mchsproud
- **Reach:**
  - Facebook: 97,200
  - Instagram: 5,900
  - Twitter – n/a
  - Messages to Parents (via Thrillshare) 24
- **Press Releases**
  - "Minooka Community High School Students Earn Director Awards from the Grundy Area Vocational Center" (April 5, 2024)
  - "Minooka Community High School Teacher to Participate in Summer Conference and Field Study in South Korea" (April 10, 2024)
  - "Minooka Community High School Earns National Recognition as a NHSSCA Program of Excellence" (April 12, 2024)
  - "Minooka Community High School Senior Named Rotary Club 'Student of the Month' for April" (April 15, 2024)

#### D. Events/Activities Promoted

- 9<sup>th</sup> Grade Illinois Dental Requirement (now-May 15)
- Summer Athletic Camps (now-end of semester)
- Student Services Lunch & Learns (now-end of semester)
- Student Services Career Talks (now-end of semester)
- Shorewood Troy Library Career-Con (March 25-27)
- Athletic Booster Meeting (April 8)
- Cap & Gown Pickup (April 8-9)
- Foundation of Academic Excellence (April 9)
- PSAT & SAT Testing (April 10)
- 2024 Orchestras Showcase (April 12)
- ACT Test Registration (April 13)
- JJC Annual LatinX Empowerment Conference (April 19)
- Transportation Job Fair (April 20)
- Special Olympics Run 4 Respect (April 21)
- Early Release Day (April 24)
- TALK Day (April 25)

- Junior/Senior Prom (April 26)
- Spring Blood Drive (May 2)
- Jazz & Percussion Concert (May 2)
- Poetry Night (May 3)
- Staff Appreciation Week (May 6-10)
- Spring Choir Concert & Awards (May 7)
- Senior Honors Night (May 8)
- Spring Band Concert (May 9)
- Athletic Booster Club Meeting (May 13)
- Seniors Last Day (May 14)
- Graduation Practice (May 17)
- Senior Sunset (May 17)
- Graduation (May 19)
- Diploma Pick Up (May 20-21)
- Final Assessments (May 22-24)
- Foundation of Educational Excellence Meeting (June 13)

**MINOOKA COMMUNITY HIGH SCHOOL  
DISTRICT #111  
COMMITTEE MEETING  
WEDNESDAY MARCH 13, 2024**

**CALL TO ORDER**

The meeting was called to order at 5:30 p.m. by Vice President Laura Hrechko. The meeting was held at Minooka Community High School-Central Campus in the library. A physical quorum was present with the following board members answering roll call:

	YES	NO
• Mike Brozovich		X
• Laura Hrechko	X	
• Tim Juskiewicz	X	
• Mike Hoyt	X	
• Jim Grzetich	X	
• Matt Shepard	X	
• Terry Spivey	X	

Additionally present were:

• Kristi Boe	X
• Jamie Soliman	X
• Phil Pakowski	X
• John Troy	X
• Robert Schiffbauer	X
• Michele Williamson	X

**PUBLIC COMMENTS**

There were no public comments heard.

**DISCUSSION**

Update 2023-2024 School Calendar:

A proposal for amending the 2023-2024 school calendar was provided in the board packet for review. Due to the SAT test being shortened for April 10, 2024. It is proposed to make the school day from a “C” day to a “Half Day” school improvement day. There is a provision within the school code that allows a half day/school improvement day. Dr. Schiffbauer added that this does not change anything except properly designating the day with the State. There were no concerns and it is anticipated for approval at the regular board meeting.

Board of Education Meeting Dates FY25:

A draft of the FY 25 Board of Education meeting dates was provided in the board packet for review. Dr. Schiffbauer stated in the past the regular meeting has been moved up due to the School Board Conference. This is achievable but it does affect the process approving bills. Dr. Schiffbauer asked for board members thoughts on the November meeting date. In addition, Committee of the whole meetings would be scheduled for August, September, January, March, and April. The meetings will take place in the boardroom at the new District Administration Building. If there are no concerns with the meeting dates proposed, it will be anticipated for approval at the regular board meeting.

**National Investigations:**

A Quote from the National Investigations Inc. for paperless residency /registration was provided in the board packet for review. This service provides residency screenings for MCHS families and proactively prevents students from outside the district to register. This also allows a more streamlined registration process and also eliminates the current service which offers less. This maintains the integrity of the district's boundaries. The average out of district student cost is \$17,000, flagging 1-2 out of district students will save the district more than the initial cost of the service. There were no concerns and it is anticipated for approval at the regular board meeting.

**Overnight Requests:**

The following overnight/out of state requests were provided in the board packet for review.

- Indoor Percussion Out of State Competition - Dayton, OH – April 17-20, 2024
- TSA State Conference – Bloomington, IL – April 4 and 5, 2024

There were no objections and it is anticipated for approval at the March regular board meeting.

**Policy****Revised Depreciation Policy – First Reading:**

The revised depreciation policy was provided in the board packet for review for a first reading. There were no concerns or objections and a second reading and possible adoption will be held at the March meeting.

**Handbook Revision:**

The School Improvement Team reviewed school handbook policies. The team focused on the Attendance Policy and excessive absences. The team felt that the academic punitive action should be removed and add steps for student attendance interventions. Mr. Wikoff and Mr. Kevin Murphy feels that this also aligns more with the school code. There were no concerns and it is anticipated for a second reading at the regular board meeting.

**Building and Grounds****Constructions Meeting Minutes for Office Remodel:**

The Office Remodel Construction Meeting Minutes were provided in the board packet for review. Dr. Schiffbauer reported that the new sign is on the administration building. Projects are moving along such as windows and HVAC units are being delivered. Dr. Schiffbauer added that elevator changes were presented and he will keep board members up to date with costs through meetings or his weekly updates. The projected timeframe of completion is the end of May with possible move to the building in early June.

**Technology****Internet and Security Technology for Office Building:**

The Internet and Security proposal was provided in the board packet for review. As discussed in a February 23<sup>rd</sup> memo to board members the district would like to subcontract internet and security technology for the office building. This includes access control, security video cameras, phones, automated lockdown system and internet access points/switches. The total cost is \$124,092. There were no objections from board members to proceed and it is anticipated for formal approval at the regular board meeting.

**Finance Committee**

Financial Reports:

Financial reports were provided in the board packet and reviewed.

Marching Band Uniforms:

Dr. Schiffbauer stated that band uniform quotes are being finalized. It is estimated that the cost for approximately 300 uniforms will be anywhere from the \$90,000 - \$100,000 range. The new uniforms are machine washable and no dry cleaning is involved. It was confirmed that the cost to dry clean the current uniforms is \$8,000 a year. Details are anticipated to be provided at the April meeting for consideration and possible approval. There were no concerns however it was asked if there were original uniforms from each uniform change.

**Personnel**

Other:

Mr. Troy reported that the Bus Lease Bids were received from Midwest Bus Sales and Central States. The district is requesting seven 71passenger busses and three wheelchair busses. Mr. Troy will review bids with District 201. This final recommendation will be provided for consideration and possible approval at the April regular meeting. There were no concerns or questions raised from board members.

**Announcements and Communication**

**ADJOURNMENT**

MOTION: by Juskiewicz, seconded by Hoyt to adjourn the meeting. Hearing no objections, the motion was approved. Time: 6:57 p.m.

\_\_\_\_\_  
LAURA HRECHKO, VICE PRESIDENT

\_\_\_\_\_  
TIM JUSKIEWICZ, SECRETARY

\_\_\_\_\_  
Date

\_\_\_\_\_  
Date

**MINOOKA COMMUNITY HIGH SCHOOL  
DISTRICT #111  
REGULAR MEETING  
WEDNESDAY, MARCH 20, 2024**

**CALL TO ORDER**

The regular meeting was called to order at 6:00 p.m. by Vice President Laura Hrechko. The meeting was held at Minooka Community High School-Central Campus in the Library. A physical quorum was present with the following board members answering roll call:

	YES	NO
• Mike Brozovich		X
• Laura Hrechko	X	
• Tim Juskiewicz	X	
• Mike Hoyt		X
• Jim Grzetich	X	
• Matt Shepard	X	
• Terry Spivey	X	

Additionally, present were:

- Dr. Rob Schiffbauer X
- John Troy X
- Dr. Phillip Pakowski X
- Kristi Boe X
- Jamie Soliman X
- Michele Williamson X

The Pledge of Allegiance was recited.

**COMMUNICATIONS/RECOGNITION**

Members of the Girls Bowling Team along with Coach Yudzentis and Coach Resner were recognized for their 2<sup>nd</sup> place finish at the IHSA State Championship.

**PUBLIC COMMENTS**

Board member Tim Juskiewicz acknowledged the Beauty and the Beast Musical students and staff on a fantastic job.

**ADMINISTRATIVE REPORTS**

Administrative reports were provided in the board packet for review.

Dr. Schiffbauer added that a Beauty and Beast Musical Senior Matinee was offered for senior citizens on March 13<sup>th</sup>. Approximately 300 senior citizens attended and a reception prior to the musical was held with refreshments and an opportunity to mingle with community and MCHS Staff. The Community Leaders Breakfast was held on March 1<sup>st</sup> with 117 community leaders in attendance.

Dr. Schiffbauer updated board members on information regarding HB 5617 which would ban all native mascots and imagery. This bill has been assigned to a committee. Dr. Schiffbauer added this would have a significant financial impact on the district. The legislative is currently written that any uniforms/fabric with the native logo would need to be cycled out by Fall 2027, in addition any building items would be required to be cycled out as the district remodels. Dr. Schiffbauer stated that a hearing will be heard tomorrow morning and he could submit a witness slip on behalf of the district. There were no objections from board members present to have Dr. Schiffbauer submit a witness slip against the bill. It was suggested and discussed to send out communication to the district/community to reach out to State Representatives and State Senators. There were no objections and Dr. Schiffbauer added that an awareness communication plan can be developed and he will keep board members updated.

### **CONSENT AGENDA**

MOTION: by Grzetich, seconded by Shepard, to approve the consent agenda as presented:

- A. Open Session Minutes
  - 1. February 21, 2024 Regular Board Meeting
- B. Financial Reports
  - 1. Monthly Financial Reports
  - 2. Payment of Bills/Total
  - 3. Employee Payroll
  - 4. Imprest Fund Report/Total
  - 5. Activity Fund Report
  - 6. Treasurer's Report (Cash/YTD – Exp/Rev)

Hearing no objections. Motion was approved. Time: 6:20 p.m.

### **COMMITTEE REPORTS**

Building and Grounds – Pre-construction and construction meeting minutes for the office building remodel were provided in the board packet for review. Mr. Shepard recapped the March 13<sup>th</sup> discussion items. In addition, an environmental consultant came in, asbestos was found in the main gym floor at Central and a bid proposal was received to abate the asbestos. Another consultant that DLA utilizes will also take a second look. Dr. Schiffbauer estimates the cost of a full abatement with consultant fees could be \$250,000. It is a 3-week process and when all the information is received, board members will be updated. There were no objections.

Finance – Mrs. Hrechko gave an update from the March 13<sup>th</sup> committee meeting.

Personnel – was held on March 13<sup>th</sup> and will continue in executive session.

Policy – was held on March 13<sup>th</sup>.

Technology – was held on March 13<sup>th</sup>.

GAVC – will be held on March 21, 2024

GCSEC – Dr. Schiffbauer reported that various students who are outplaced have decreased and certain students who currently utilize GCSEC could potentially be placed at Minooka Academy.

**DISCUSSION ITEMS**

## Educational Foundation Update:

The Educational Foundation update was included in the board packet for review. Dr. Schiffbauer stated the next meeting is scheduled for April 9<sup>th</sup>, 2024.

## Policy Review:

The March 2024 policy review was provided in the board packet for review. The following policies were reviewed:

- 2:100 Board Member Conflict of Interest
- 5:300 Schedules and Employment Year

## Bus Lease Bid:

Bus Lease Bids with Midwest Bus Sales, Midwest Transit and Central States were provided in the board packet for review Mr. Troy reported that the recommendation is to award the bus lease bids to the following:

Midwest Bus Sales; Purchase Two (2) 2023 New Mintour 18+1 Passenger Lift Bus;

Central States; Purchase Seven (7) 2025 New Bluebird 77 Passenger bus and One (1) 2023 used Bluebird 37 passenger lift bus

Lease Financing; Five (5) year lease Agreement with American Capital for 2 Mintours at \$19,270 bus/year, 7 77 Passenger Bluebirds at \$22,026 bus/year and 1 used 37 Passenger lift bus at \$24,008/year (lease to own)

There were no objections or concerns and it is anticipated for approval at the end of the regular board meeting.

## Handbook Revision – First Reading:

The proposed student handbook revisions were provided in the board packet for a first reading. There were no concerns or objections for a second reading at the April committee meeting.

## Pro Motion Contract:

The Mutual Release Agreement with Pro Motion was provided in the board packet for review. Dr. Schiffbauer reported that he and Mr. Troy met with Pro Motion and with the athletic training staffing issues it was a mutual decision to part ways. Administration's recommendation is to accept the release agreement and to hire the Athletic Trainer candidate who is a former MCHS graduate and has worked well Mr. Highbaugh. There were no concerns or objections and it is anticipated for approval at the end of the regular board meeting.

**ACTION ITEMS**

Approval of the update to the 2023-2024 School Calendar as presented:

MOTION: by Grzetich, seconded by Shepard to approve the update to the 2023-2024 School Calendar as presented. Hearing no objections. Motion was approved. Time: 6:35 p.m.

Approval of the FY25 Board of Education Meeting Dates as presented.

MOTION: by Juskiewicz, seconded by Grzetich, to approve the FY25 Board of Education Meeting Dates as presented. Hearing no objections. Motion was approved. Time: 6:35 p.m.

Approval of the Purchase of National Investigations, Inc. Services in the total amount of \$8,351.25 as presented.

MOTION: by Shepard, seconded by Spivey to approve the Purchase of National Investigations, Inc. Services in the total amount of \$8,351.25 as presented. Hearing no objections. Voting Aye: Juskiewicz, Hrechko, Grzetich, Shepard, and Spivey. Motion carried. Time: 6:36 p.m.

Approval and Adoption of the Revised Depreciation Policy as presented.

MOTION: by Grzetich, seconded by Shepard to approve and adopt the Revised Depreciation Policy as presented. Hearing no objections. Motion was approved. Time: 6:36 p.m.

Approval of the Transportation School Bus lease 2024-2025 school year as follows:

**Midwest Bus Sales**; Purchase Two (2) 2023 New Mintour 18+1 Passenger Lift Bus; **Central States**; Purchase Seven (7) 2025 New Bluebird 77 Passenger bus and One (1) 2023 used Bluebird 37 passenger lift bus

**Lease Financing**; Five (5) year lease Agreement with American Capital for 2 Mintours at \$19,270 bus/year, 7 77 Passenger Bluebirds at \$22,026 bus/year and 1 used 37 Passenger lift bus at \$24,008/year (lease to own)

MOTION: by Grzetich, seconded by Shepard to approve the Transportation School Bus lease 2024-2025 school year as follows:

**Midwest Bus Sales**; Purchase Two (2) 2023 New Mintour 18+1 Passenger Lift Bus; **Central States**; Purchase Seven (7) 2025 New Bluebird 77 Passenger bus and One (1) 2023 used Bluebird 37 passenger lift bus

**Lease Financing**; Five (5) year lease Agreement with American Capital for 2 Mintours at \$19,270 bus/year, 7 77 Passenger Bluebirds at \$22,026 bus/year and 1 used 37 Passenger lift bus at \$24,008/year (lease to own) as presented. Voting Aye: Shepard, Spivey, Juskiewicz, Hrechko, and Grzetich. Motion carried. Time: 6:37 p.m.

Approval of the Dissolution of the Pro Motion Contract as presented.

MOTION: by Shepard, seconded by Spivey to approve the Dissolution of the Pro Motion Contract as presented. Voting Aye: Grzetich, Shepard, Spivey, Juskiewicz, and Hrechko. Motion carried. Time: 6:37 p.m.

Approval to Purchase Access Control with ITR Systems in the amount of \$15,945 dollars as presented.

MOTION: by Juskiewicz, seconded by Grzetich to approve the purchase Access Control with ITR Systems in the amount of \$15,945 dollars as presented. Voting Aye: Spivey, Juskiewicz, Hrechko, Grzetich, and Shepard. Motion carried. Time: 6:37 p.m.

Approval to Purchase Video Cameras with ITR Systems in the amount of \$25,950 dollars as presented.

MOTION: by Grzetich, seconded by Shepard to approve the purchase Video Cameras with ITR Systems in the amount of \$25,950 dollars as presented. Voting Aye: Hrechko, Grzetich, Shepard, Spivey, and Juskiewicz. Motion carried. Time: 6:38 p.m.

Approval to Purchase Phones with Rival5 Technologies in the amount of \$7,044 dollars as presented.

MOTION: by Juskiewicz, seconded by Grzetich to approve the purchase Phones with Rival5 Technologies in the amount of \$7,044 dollars as presented. Voting Aye: Spivey, Juskiewicz, Hrechko, Grzetich, and Shepard. Motion carried. Time: 6:38 p.m.

Approval to Purchase the Automated System with ITR/Rival5 in the amount of \$21,983 dollars as presented.

MOTION: by Shepard, seconded by Juskiewicz to approve the Automated System with ITR/Rival 5 in the amount of \$21,983 dollars as presented. Voting Aye: Hrechko, Grzetich, Shepard, Spivey, and Juskiewicz. Motion carried. Time: 6:39 p.m.

Approval to Purchase Internet Access/Switches with Sentinel in the amount of \$53,170 dollars as presented.

MOTION: by Grzetich, seconded Shepard, to approve the purchase Internet Access/Switches with Sentinel in the amount of \$53,170 dollars as presented. Voting Aye: Spivey, Juskiewicz, Hrechko, Grzetich, and Shepard. Motion carried. Time: 6:39 p.m.

Approval of the Indoor Percussion Out of State Overnight Request as presented.

MOTION: by Juskiewicz, seconded by Grzetich to approve the Indoor Percussion Out of State Overnight Request as presented. Hearing no objections. Motion was approved. Time: 6:39 p.m.

Approval of the TSA State Conference Overnight Request as presented.

MOTION: by Grzetich, seconded by Juskiewicz to approve the TSA State Conference Overnight Request as presented. Hearing no objections. Motion was approved. Time: 6:40 p.m.

### **EXECUTIVE SESSION**

MOTION: by Juskiewicz, seconded by Shepard to adjourn the meeting to executive session for the purpose of discussing matters related to minutes, the appointment, compensation, discipline, dismissal, employment and performance of specific employees of the district, student discipline and collective bargaining. Hearing no objections. Motion was approved. Time: 6:40 p.m.

### **RETURN TO OPEN SESSION**

MOTION: by Shepard, seconded by Juskiewicz. Hearing no objections. Motion was approved. Time: 7:43 p.m.

### **ACTIONS FOLLOWING EXECUTIVE SESSION**

Laura Hrechko was appointed President Pro Tem for the regular board meeting. There were no objections.

MOTION: by Juskiewicz, seconded by Spivey, to approve the closed session minutes as presented:

February 21, 2024 Executive Regular Meeting

Hearing no objections, the motion was approved. Time: 7:47 p.m.

### Personnel

Resignation(s):

MOTION: by Juskiewicz, seconded by Shepard, to accept the following resignation/retirement(s) as presented:

Everlena Smith – Transportation Director – effective 3/8/2024

Kevin Marcano – Special Education Teacher – effective 5/24/2024

Hearing no objections, the motion was approved. Time: 7:47 p.m.

LOA:

MOTION: by Grzetich, seconded by Shepard, to accept the following LOA as presented

Dan Dawson – Custodian – 3/19/2024 – 8/31/2024 (Days TBD) under the Family Medical Leave Act (FMLA)

Hearing no objections, the motion was approved. Time: 7:48 p.m.

Employment:

MOTION: by Juskiewicz, seconded by Shepard to approve that the employment contracts of the following part-time teachers to be terminated at the conclusion of the 2023-2024 school term per customary practice, and that the Superintendent give written notice of termination to such:

Emily Vandergrift

Rhiannon Seaborg

Voting Aye: Spivey, Juskiewicz, Hrechko, Grzetich, and Shepard. Motion carried. Time: 7:48 p.m.

MOTION: by Spivey, seconded Juskiewicz to adopt the resolution for the non-renewal of probationary certified staff at the conclusion of the 2023/2024 school term, and that the Superintendent give written notice of this termination to such:

Stephanie McCollom

George Shimko

Voting Aye: Shepard, Spivey, Juskiewicz, Hrechko, and Grzetich. Motion carried. Time: 7:49 p.m.

MOTION: by Shepard, seconded by Juskiewicz to approve the reassignments as presented.

Emily Brown - From Athletic Director to Special Education Teacher

Karolyn Landstrom – From Spanish Teacher (part-time) to ELL Teacher (full-time)

Voting Aye: Hrechko, Grzetich, Shepard, Spivey and Juskiewicz. Motion carried. Time: 7:49 p.m.

MOTION: by Grzetich, seconded by Spivey to approve the affirmation of Returning Administrative Staff as presented:

- Tracey Adams - Department Chair - Math
- Kristi, Boe - Director of Human Resources
- Jon Calder - Department Chair - CTE
- Jeff Easton - Department Chair - World Languages, World and Art
- Chris Erickson - Department Chair - Science
- Hillary Holden - Director of Student Activities
- Kevin Murphy - Assistant Principal
- Kathi Norman - Director of Finance
- Phil Pakowski - Director of Curriculum and Instruction
- Chris Pendergast - Department Chair - Social Studies
- Matt Shanahan - Department Chair - Special Education
- JaRita Steward - Department Chair - English
- Matt Wikoff - Assistant Principal
- Matt Williams - Department Chair - P.E./Health/Driver's Ed

Voting Aye: Shepard, Spivey, Juskiewicz, Hrechko, and Grzetich. Motion carried. Time: 7:50 p.m.

MOTION: by Grzetich, seconded by Shepard to approve the affirmation of Returning Non-Certified Directors:

- Cathy Haase - Director of Transportation
- Aubrey Knight - Director of Community Relations
- Jim Kelly - Director of Technology
- Jason Piper - Director of Buildings and Grounds

Voting Aye: Juskiewicz, Hrechko, Grzetich, Shepard, and Spivey. Motion carried. Time: 7:50 p.m.

NO MOTION (Informational): the re-employment and placement of the presented certified staff on Probationary Status for the 2024/2025 school year:

Second Year Probationary

- Carter, Patrick
- Clancy, Meghan
- Curatolo, Nicholas
- Flynn, Shannon
- Gnat, Dylan
- Kanak, Tiffany
- Kelly, Alison
- Kovanda, JoDee
- Kunz, Bradley
- Marren, Nora
- Norman, Kathryn
- Pawlak, Abigail
- Pawlak, Ryan
- Reick, Samantha
- Rubino, Kayla

- Temple, Jenna
- Vahl, Michael
- Van Dyke, David

#### Third Year Probationary

- Bachmann, Bethany
- Barrera Maia
- Bednarz, Meghan
- Bell, Eleanore
- Boe, Kristi
- Davis, Robert
- Harrison, Timothy
- Heery, Shayla
- O'Sha, Rebecca
- Sallade, Michael
- Ward, Dani

#### Fourth Year Probationary

- Steward, JaRita

NO MOTION (Informational): that the presented certified staff be re-employed and placed on tenured status at the start of the 2024/2025 school year, pursuant to statutes of the Illinois School Code:

- Acosta, Brendan
- Baumann, Malarie
- Bell, Joshua
- Burton, Edson
- Cheney, Megan
- Flanagan, Ryan
- Kaminski, Georgia
- Baker, Candace
- Caldwell, Megan
- Cichon, Stephanie
- Erickson, Christopher
- Langhoff, Barbara
- Madding, Susanne
- Micetich, Nicholas
- Rink, Anthony
- Swiatek, Valerie
- Tagler, Christopher
- Watson, Patrick

MOTION: by Grzetich, seconded by Shepard, to approve the employment of the following certified staff member(s) for the 2024/2025 school year as presented, pending proper paperwork and background check deemed favorable by the MCHS #111 Administration:

Brett Hespell - First Year Probationary Teacher - Social Studies (MA+15) Step 18

Voting Aye: Spivey, Juskiewicz, Hrechko, Grzetich, and Shepard. Motion carried. Time: 7:52 p.m.

MOTION: by Grzetich, seconded Spivey to approve the employment of the following support staff member(s) as presented, pending proper paperwork and background check deemed favorable by the MCHS #111 Administration:

Hannah Midlock - Athletic Trainer - \$52,500

Voting Aye: Shepard, Spivey, Juskiewicz, Hrechko, and Grzetich. Motion carried. Time: 7:52 p.m.

MOTION: by Grzetich, seconded by Juskiewicz to approve the Memorandum of Understanding with Minooka Transportation Association as presented.

Voting Aye: Hrechko, Grzetich, Shepard, Spivey and Juskiewicz. Motion carried. Time: 7:52 p.m.

MOTION: by Shepard, seconded by Spivey to approve Administration, Non-Union Support Staff and Transportation Support Staff Raises for the 2024-2025 School Year as presented.

Voting Aye: Juskiewicz, Hrechko, Grzetich, Shepard, and Spivey. Motion carried. Time: 7:53 p.m.

**ADJOURNMENT**

MOTION: by Juskiewicz, seconded by Shepard to adjourn the meeting.

Voting Aye: Spivey, Juskiewicz, Hrechko, Grzetich, and Shepard. Motion carried. Time: 7:53 p.m.

---

LAURA HRECHKO, PRESIDENT PRO TEM

---

TIM JUSKIEWICZ, SECRETARY

---

Date

---

Date

# Monthly Financial Report - March, 2024

The revenues for the month of March in all funds were \$1,883,077.03 which is 2.55% of the annual budgeted revenue. Total revenue year-to-date was \$52,427,246.89, which is 71.04% of the annual budget revenue. Annual budgeted revenues for the year is \$73,800,295.50.

The expenditures for the month of March in all funds were \$4,804,746.26, which is 6.05% of the annual budgeted expenses. Total expenses year-to-date was \$51,461,179.13, which is 64.85% of the annual budget expense. Annual budgeted expense for the year is \$79,359,173.83.

Enrollment (May 31st)	2,952	South Campus	300,000 sq. ft. / 67 acres
Administrators	18	Central Campus	250,000 sq. ft. / 78 acres
Teachers Full-Time	179	Teachers Part-Time	4
Teachers LOA	0	Support Staff	121

Table 1: Year-to-Date Revenue Expense Summary

Year to Date Revenue Expenses vs. Budget	Revenue Budget	Year to Date Revenue	Expense Budget	Year to Date Expenses	Budget Deficit/Surplus	Current Deficit/Surplus
Education Fund *	45,752,766.57	33,756,519.85	45,749,758.99	31,494,514.25	3,007.58	2,262,005.60
Activity Fund	953,300.00	515,607.88	947,900.00	496,751.84	5,400.00	18,856.04
Operations & Maint Fund *	5,668,775.96	3,823,618.93	5,564,069.11	3,815,900.28	104,706.85	7,718.65
Debt Service Fund or Fund Group	8,776,628.32	5,845,845.59	8,543,500.00	6,304,400.00	233,128.32	(458,554.41)
Transportation Fund *	3,699,708.76	2,772,695.01	3,556,861.58	2,171,259.69	142,847.18	601,435.32
I.M.R.F./Soc. Sec. Fund	1,275,300.85	872,186.52	1,273,420.27	725,372.66	1,880.58	146,813.86
Capital Projects Fund or Fund Group	3,713,268.00	2,012,490.96	11,150,019.20	5,284,993.57	(7,436,751.20)	(3,272,502.61)
Working Cash Fund *	1,295,504.89	1,005,486.48	0.00	0.00	1,295,504.89	1,005,486.48
Tort Immunity and Judgment Fund	1,644,537.26	1,096,663.40	1,573,644.68	1,167,986.84	70,892.58	(71,323.44)
Fire Prevention & Safety Fund	1,020,504.89	726,132.27	1,000,000.00	0.00	20,504.89	726,132.27
<b>Total All Funds</b>	<b>73,800,295.50</b>	<b>52,427,246.89</b>	<b>79,359,173.83</b>	<b>51,461,179.13</b>	<b>(5,558,878.33)</b>	<b>966,067.76</b>
<b>* Total Operating Funds</b>	<b>56,416,756.18</b>	<b>41,358,320.27</b>	<b>54,870,689.68</b>	<b>37,481,674.22</b>	<b>1,546,066.50</b>	<b>3,876,646.05</b>

Table 2: Month Revenue and Expense

Mar	* Education Fund	* Operations & Maint Fund	Debt Service Fund or Fund Group	* Transportation Fund	I.M.R.F./Soc. Sec. Fund	Capital Projects Fund or Fund Group	* Working Cash Fund	Tort Immunity and Judgment	Fire Prevention & Safety Fund	Activity Fund	Total All Funds	* Total Operating Funds
Revenue	1,491,702	65,604	26,227	32,116	23,308	81,364	57,556	20,276	22,621	62,305	1,883,077	1,646,977
Expense	3,487,034	58,217	500	202,244	80,897	840,998	0	101,644	0	33,213	4,804,746	3,747,494
Net	(1,995,332)	7,387	25,727	(170,128)	(57,589)	(759,634)	57,556	(81,369)	22,621	29,092	(2,921,669)	(2,100,517)

Table 3: Expenses by Object - Monthly

Monthly Expenses by Object	Salaries	Employee Benefits	Purchased Services	Supplies And Materials	Capital Outlay	Other	Total
July	1,706,842.76	1,178,698.84	1,704,047.09	313,153.57	588,142.87	602,351.51	6,093,236.64
August	1,802,343.48	1,121,850.41	528,698.46	263,364.69	100,972.47	292,448.91	4,109,678.42
September	1,869,184.01	1,113,917.88	850,433.19	421,570.69	31,198.16	1,077,302.97	5,363,606.90
October	1,817,597.78	1,142,929.48	810,867.85	303,953.18	11,530.50	2,860,159.45	6,947,038.24
November	1,842,787.75	1,122,307.43	805,722.94	348,057.52	201,733.73	3,605,706.04	7,926,315.41
December	1,905,339.56	1,081,294.34	1,079,534.32	331,989.79	267,901.01	560,003.05	5,226,062.07
January	1,836,148.93	1,220,792.53	1,198,239.47	123,555.15	19,522.20	1,494,093.38	5,892,351.66
February	1,893,492.79	1,116,738.06	1,209,661.48	290,223.53	89,863.79	498,163.88	5,098,143.53
March	1,828,107.92	1,227,745.91	918,422.62	206,965.71	105,707.87	517,796.23	4,804,746.26
April	0.00	0.00	0.00	0.00	0.00	0.00	0.00
May	0.00	0.00	0.00	0.00	0.00	0.00	0.00
June	0.00	0.00	0.00	0.00	0.00	0.00	0.00
YTD	16,501,844.98	10,326,274.88	9,105,627.42	2,602,833.83	1,416,572.60	11,508,025.42	51,461,179.13

Chart 1: MTD, YTD, & Budget Expenses by Object

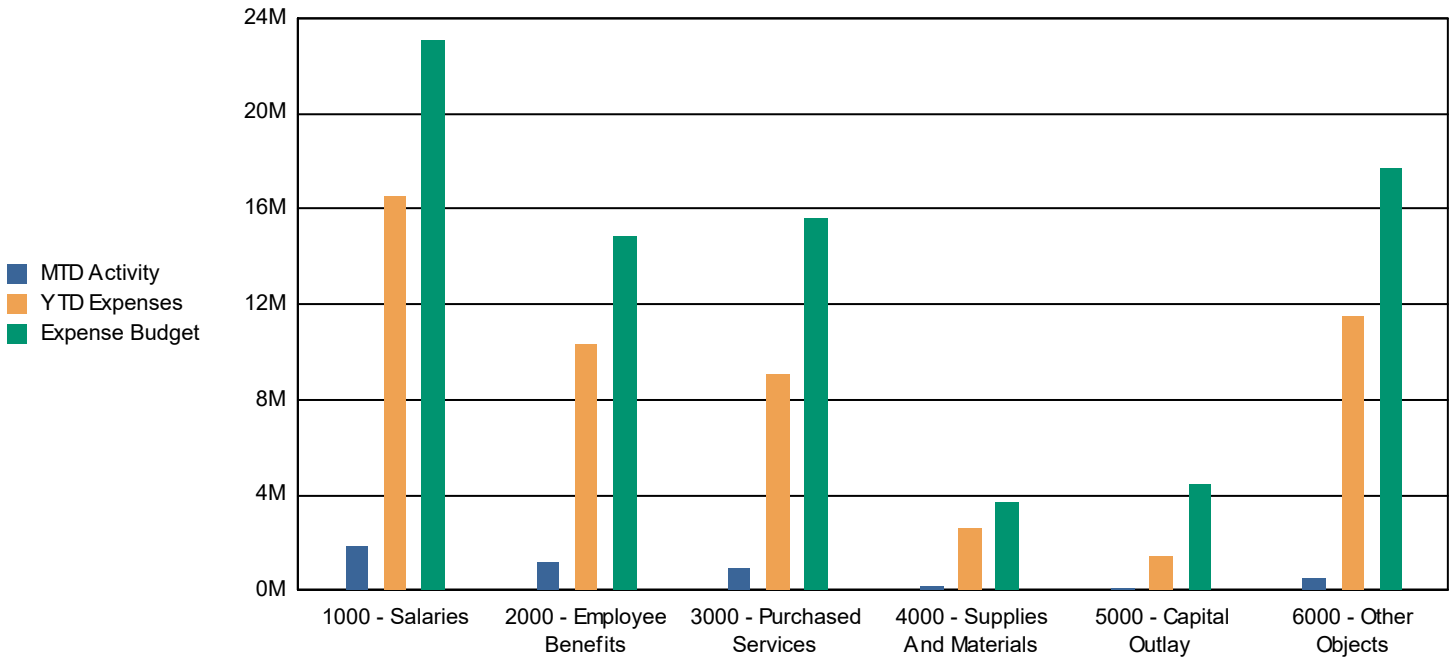
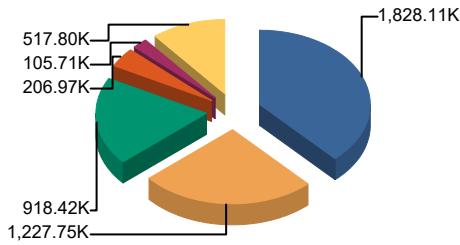

Table 4: Expenses by Object; Budget vs. Year to Date and Three Year History

Annual Expense Summary by Object	Budget 2023-2024	Actual Year to Date 2023-2024	Percent of Budget Expended	Actual Year End		
				2022-2023	2021-2022	2020-2021
Salaries	23,065,689.59	16,501,844.98	71.54%	21,016,995.85	19,915,521.64	18,915,448.18
Employee Benefits	14,850,913.26	10,326,274.88	69.53%	13,104,479.53	11,484,313.56	9,821,573.72
Purchased Services	15,581,322.78	9,105,627.42	58.44%	6,614,342.63	5,794,214.95	5,150,233.25
Supplies And Materials	3,740,218.00	2,602,833.83	69.59%	3,627,844.83	2,977,283.97	1,948,916.62
Capital Outlay	4,427,078.20	1,416,572.60	32.00%	6,982,731.12	2,946,524.65	6,922,233.77
0000	17,693,952.00	11,508,025.42	65.04%	45,546,655.14	25,632,133.79	13,500,021.63
<b>Total</b>	<b>79,359,173.83</b>	<b>51,461,179.13</b>	<b>64.85%</b>	<b>96,893,049.10</b>	<b>68,749,992.56</b>	<b>56,258,427.17</b>

Chart 2: Monthly Expense



1000 - Salaries 1,828.11K 38.0%  
 2000 - Employee Benefits 1,227.75K 25.6%  
 3000 - Purchased Services 918.42K 19.1%  
 4000 - Supplies And Materials 206.97K 4.3%  
 5000 - Capital Outlay 105.71K 2.2%  
 6000 - Other Objects 517.80K 10.8%  
 Total: 4,804.75K 100.0%

Chart 3: Year to Date Expense

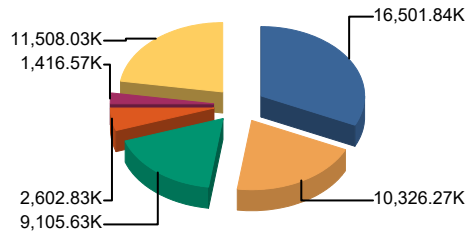

1000 - Salaries 16,501.84K 32.1%  
 2000 - Employee Benefits 10,326.27K 20.1%  
 3000 - Purchased Services 9,105.63K 17.7%  
 4000 - Supplies And Materials 2,602.83K 5.1%  
 5000 - Capital Outlay 1,416.57K 2.8%  
 6000 - Other Objects 11,508.03K 22.4%  
 Total: 51,461.18K 100.0%

Chart 4: Budget

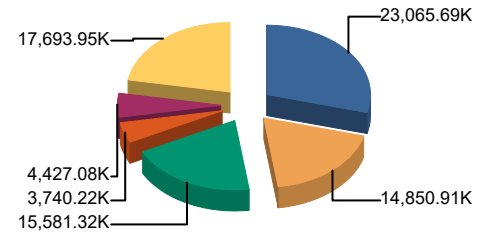

1000 - Salaries 23,065.69K 29.1%  
 2000 - Employee Benefits 14,850.91K 18.7%  
 3000 - Purchased Services 15,581.32K 19.6%  
 4000 - Supplies And Materials 3,740.22K 4.7%  
 5000 - Capital Outlay 4,427.08K 5.6%  
 6000 - Other Objects 17,693.95K 22.3%  
 Total: 79,359.17K 100.0%

Table 5: Expenses by Fund - Monthly

Monthly Expenses by Fund	Education Fund	Operations & Maint Fund	Debt Service Fund or Fund Group	Transportation Fund	I.M.R.F./Soc. Sec. Fund	Capital Projects Fund or Fund	Working Cash Fund	Tort Immunity and Judgment	Fire Prevention & Safety Fund	Total
July	3,888,555.64	516,437.20	0.00	720,709.35	71,505.51	775,800.84	0.00	82,545.03	0.00	6,093,236.64
August	3,139,485.19	501,585.10	0.00	18,252.51	76,506.79	0.00	0.00	348,208.89	0.00	4,109,678.42
September	3,852,423.34	512,291.35	0.00	234,918.78	83,844.39	495,970.09	0.00	103,102.57	0.00	5,363,606.90
October	3,426,240.35	318,777.52	2,332,775.00	197,630.17	82,760.08	412,282.86	0.00	85,808.81	0.00	6,947,038.24
November	3,274,374.81	728,180.37	3,155,125.00	257,147.63	79,758.54	235,437.16	0.00	108,489.89	0.00	7,926,315.41
December	3,470,552.30	390,188.25	0.00	216,391.14	86,275.18	924,451.00	0.00	91,977.37	0.00	5,226,062.07
January	3,502,064.19	388,023.83	816,000.00	165,984.36	78,542.49	790,428.32	0.00	125,733.45	0.00	5,892,351.66
February	3,453,784.54	402,199.89	0.00	157,982.18	85,282.93	809,625.15	0.00	120,476.40	0.00	5,098,143.53
March	3,487,033.89	58,216.77	500.00	202,243.57	80,896.75	840,998.15	0.00	101,644.43	0.00	4,804,746.26
April	0.00	0.00	0.00	0.00	0.00	0.00	0.00	0.00	0.00	0.00
May	0.00	0.00	0.00	0.00	0.00	0.00	0.00	0.00	0.00	0.00
June	0.00	0.00	0.00	0.00	0.00	0.00	0.00	0.00	0.00	0.00
YTD	31,494,514.25	3,815,900.28	6,304,400.00	2,171,259.69	725,372.66	5,284,993.57	0.00	1,167,986.84	0.00	51,461,179.13

Chart 5: MTD, YTD, & Budget Expenses by Fund

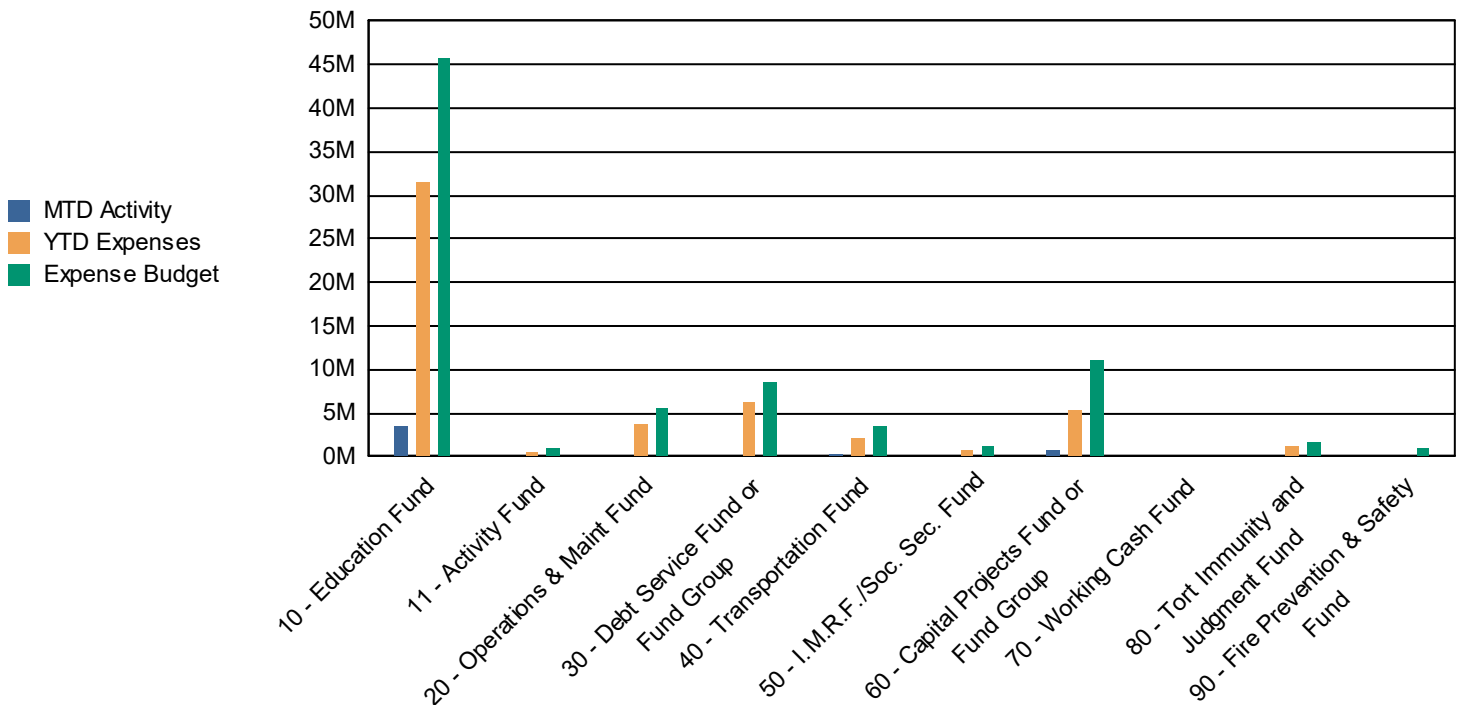

Table 6: Expenses by Fund; Budget vs. Year to Date and Three Year History

Annual Expense Summary by Fund	Budget 2023-2024	Actual Year to Date 2023-2024	Percent of Budget Expended	Actual Year End		
				2022-2023	2021-2022	2020-2021
10 - Education Fund	45,749,758.99	31,494,514.25	68.84%	50,174,254.48	37,713,360.55	32,886,815.25
11 - Activity Fund	947,900.00	496,751.84	52.41%	1,264,037.01	881,125.62	184,421.16
20 - Operations & Maint Fund	5,564,069.11	3,815,900.28	68.58%	12,813,744.53	4,055,952.76	3,542,666.07
30 - Debt Service Fund or Fund Group	8,543,500.00	6,304,400.00	73.79%	8,366,029.83	18,201,125.50	7,972,859.50
40 - Transportation Fund	3,556,861.58	2,171,259.69	61.04%	5,962,669.08	3,002,316.40	1,934,833.53
50 - I.M.R.F./Soc. Sec. Fund	1,273,420.27	725,372.66	56.96%	941,545.01	915,929.23	851,733.32
60 - Capital Projects Fund or Fund Group	11,150,019.20	5,284,993.57	47.40%	7,259,668.39	2,684,069.74	1,349,597.93
70 - Working Cash Fund	0.00	0.00	0.00%	7,000,000.00	0.00	0.00
80 - Tort Immunity and Judgment Fund	1,573,644.68	1,167,986.84	74.22%	3,111,100.77	1,296,112.76	1,281,258.00
90 - Fire Prevention & Safety Fund	1,000,000.00	0.00	0.00%	0.00	0.00	6,254,242.41
<b>Total</b>	<b>79,359,173.83</b>	<b>51,461,179.13</b>	<b>64.85%</b>	<b>96,893,049.10</b>	<b>68,749,992.56</b>	<b>56,258,427.17</b>

Chart 6: Monthly Expense

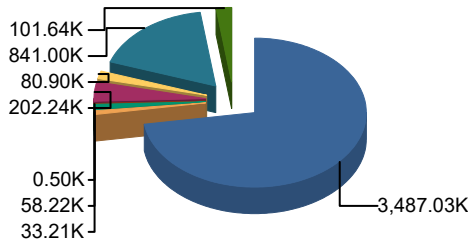

Chart 7: Year to Date Expense

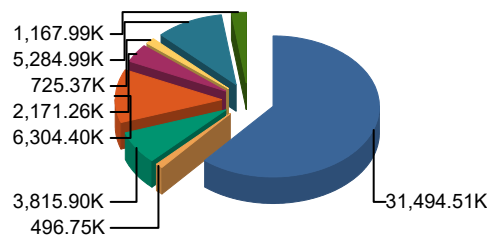
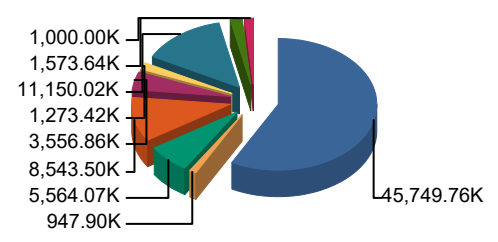

Chart 8: Budget



10 - Education Fund	3,487.03K	72.6%
11 - Activity Fund	33.21K	0.7%
20 - Operations & Maint Fund	58.22K	1.2%
30 - Debt Service Fund or Fund Group	0.50K	0.0%
40 - Transportation Fund	202.24K	4.2%
50 - I.M.R.F./Soc. Sec. Fund	80.90K	1.7%
60 - Capital Projects Fund or Fund Group	841.00K	17.5%
70 - Working Cash Fund	0.00K	0.0%
80 - Tort Immunity and Judgment Fund	101.64K	2.1%
90 - Fire Prevention & Safety Fund	0.00K	0.0%
<b>Total:</b>	<b>4,804.75K</b>	<b>100.0%</b>

10 - Education Fund	31,494.51K	61.2%
11 - Activity Fund	496.75K	1.0%
20 - Operations & Maint Fund	3,815.90K	7.4%
30 - Debt Service Fund or Fund Group	6,304.40K	12.3%
40 - Transportation Fund	2,171.26K	4.2%
50 - I.M.R.F./Soc. Sec. Fund	725.37K	1.4%
60 - Capital Projects Fund or Fund Group	5,284.99K	10.3%
70 - Working Cash Fund	0.00K	0.0%
80 - Tort Immunity and Judgment Fund	1,167.99K	2.3%
90 - Fire Prevention & Safety Fund	0.00K	0.0%
<b>Total:</b>	<b>51,461.18K</b>	<b>100.0%</b>

10 - Education Fund	45,749.76K	57.6%
11 - Activity Fund	947.90K	1.2%
20 - Operations & Maint Fund	5,564.07K	7.0%
30 - Debt Service Fund or Fund Group	8,543.50K	10.8%
40 - Transportation Fund	3,556.86K	4.5%
50 - I.M.R.F./Soc. Sec. Fund	1,273.42K	1.6%
60 - Capital Projects Fund or Fund Group	11,150.02K	14.1%
70 - Working Cash Fund	0.00K	0.0%
80 - Tort Immunity and Judgment Fund	1,573.64K	2.0%
90 - Fire Prevention & Safety Fund	1,000.00K	1.3%
<b>Total:</b>	<b>79,359.17K</b>	<b>100.0%</b>

Table 7: Revenues by Source - Monthly

Monthly Revenue by Source	Local Revenue Levy, CPPRT, Fees Etc.	Flow Through Funds	State Revenue GSA, Categoricals, Grants, Etc.	Federal Revenue IDEA, Grants, Lunch Program, Etc.	Working Cash Transfer/other	Total
July	9,553,798.42	0.00	549,551.29	9,537.95	0.00	10,112,887.66
August	5,623,023.35	0.00	689,350.00	223,226.77	0.00	6,535,600.12
September	15,413,065.74	0.00	713,284.57	22,020.89	0.00	16,148,371.20
October	2,868,622.45	0.00	1,324,069.13	311,677.00	0.00	4,504,368.58
November	1,574,906.68	0.00	689,350.00	0.00	0.00	2,264,256.68
December	1,087,082.96	0.00	708,383.38	852,947.65	0.00	2,648,413.99
January	4,355,190.72	0.00	1,235,284.49	257,051.00	0.00	5,847,526.21
February	1,777,394.61	1,441.60	703,909.21	0.00	0.00	2,482,745.42
March	1,172,589.80	0.00	709,322.83	1,164.40	0.00	1,883,077.03
April	0.00	0.00	0.00	0.00	0.00	0.00
May	0.00	0.00	0.00	0.00	0.00	0.00
June	0.00	0.00	0.00	0.00	0.00	0.00
YTD	43,425,674.73	1,441.60	7,322,504.90	1,677,625.66	0.00	52,427,246.89

Table 8: Revenue by Fund - Monthly

Monthly Revenue by Fund	Education Fund	Operations & Maint Fund	Debt Service Fund or Fund Group	Transportation Fund	I.M.R.F./Soc. Sec. Fund	Capital Projects Fund or Fund	Working Cash Fund	Tort Immunity and	Fire Prevention & Safety Fund	Total
July	5,718,110.14	981,611.37	1,575,490.41	778,792.71	234,363.21	55,700.60	213,447.23	277,555.46	181,003.35	10,112,887.66
August	4,299,051.71	507,467.01	873,876.55	241,436.09	112,639.43	48,995.47	130,798.83	155,049.87	101,148.25	6,535,600.12
September	9,476,576.97	1,546,847.37	2,780,469.98	750,424.78	330,972.48	49,200.49	343,645.45	478,239.33	313,706.09	16,148,371.20
October	3,069,343.63	289,135.19	352,112.95	437,011.16	82,099.14	46,098.01	76,447.48	67,307.78	45,996.15	4,504,368.58
November	1,708,337.02	101,204.16	142,179.91	51,957.31	21,372.16	61,236.87	59,038.47	34,959.89	27,477.97	2,264,256.68
December	1,763,354.00	75,340.89	39,569.91	32,084.69	21,318.68	582,894.05	43,645.31	21,468.64	13,024.17	2,648,413.99
January	4,151,548.45	117,379.06	36,212.10	416,568.28	37,671.51	966,927.52	41,156.86	21,883.33	10,457.64	5,847,526.21
February	2,078,496.37	139,030.37	19,707.13	32,304.03	8,442.34	120,073.63	39,750.94	19,923.22	10,697.92	2,482,745.42
March	1,491,701.56	65,603.51	26,226.65	32,115.96	23,307.57	81,364.32	57,555.91	20,275.88	22,620.73	1,883,077.03
April	0.00	0.00	0.00	0.00	0.00	0.00	0.00	0.00	0.00	0.00
May	0.00	0.00	0.00	0.00	0.00	0.00	0.00	0.00	0.00	0.00
June	0.00	0.00	0.00	0.00	0.00	0.00	0.00	0.00	0.00	0.00
YTD	33,756,519.85	3,823,618.93	5,845,845.59	2,772,695.01	872,186.52	2,012,490.96	1,005,486.48	1,096,663.40	726,132.27	52,427,246.89

Table 9: Revenue by Fund; Budget vs. Year to Date and Three Year History

Annual Revenue Summary by Fund	Budget 2023-2024	Actual Year to Date 2023-2024	Percent of Budget Expended	Actual Year End		
				2022-2023	2021-2022	2020-2021
10 - Education Fund	45,752,766.57	33,756,519.85	73.78%	52,913,313.94	39,846,707.08	33,859,587.81
11 - Activity Fund	953,300.00	515,607.88	54.09%	1,044,649.58	1,049,294.44	184,951.36
20 - Operations & Maint Fund	5,668,775.96	3,823,618.93	67.45%	10,143,192.39	5,117,365.59	4,260,424.45
30 - Debt Service Fund or Fund Group	8,776,628.32	5,845,845.59	66.61%	8,404,779.72	18,477,911.23	8,206,006.73
40 - Transportation Fund	3,699,708.76	2,772,695.01	74.94%	3,545,656.58	3,278,463.81	3,017,426.77
50 - I.M.R.F./Soc. Sec. Fund	1,275,300.85	872,186.52	68.39%	1,244,908.08	1,200,788.78	1,010,197.30
60 - Capital Projects Fund or Fund Group	3,713,268.00	2,012,490.96	54.20%	17,276,360.83	2,539,135.13	277,881.20
70 - Working Cash Fund	1,295,504.89	1,005,486.48	77.61%	1,183,701.24	876,183.58	793,663.47
80 - Tort Immunity and Judgment Fund	1,644,537.26	1,096,663.40	66.69%	1,390,884.12	1,322,196.06	1,287,598.09
90 - Fire Prevention & Safety Fund	1,020,504.89	726,132.27	71.15%	920,109.11	855,624.33	747,985.94
<b>Total</b>	<b>73,800,295.50</b>	<b>52,427,246.89</b>	<b>71.04%</b>	<b>98,067,555.59</b>	<b>74,563,670.03</b>	<b>53,645,723.12</b>

Table 10: Monthly Cash Report

Month: March 2024 Monthly Cash & Investment Report												
	Education	Oper/ Maint	Debt Service	Trans portation	IMFR/Soc Sec	Capital	Working Cash	Tort	Life & Safety	Total	Activities	Total All Funds
Checking	709,097	27,576	56,881	28,239	36,761	103,092	82,380	17,551	25,595	1,087,173	535,820	1,622,993
Food Service	906,539	-	-	-	-	-	-	-	-	906,539	-	906,539
Imprest	4,345	2,603	-	3,333	-	-	-	(250)	-	10,030	-	10,030
Insurance	1,191,377	449,647	-	174,852	-	-	-	38,781	-	1,854,658	-	1,854,658
PMA Cash Account	2,315,835	11,850	1,795,249	198,012	33,534	839,655	13,276	55,102	9,824	5,272,336	-	5,272,336
IPTIP	4,805,030	2,415,019	-	-	1,135,814	-	204,144	-	-	8,560,007	-	8,560,007
<b>Total Cash Accounts</b>	<b>9,932,223</b>	<b>2,906,695</b>	<b>1,852,131</b>	<b>404,436</b>	<b>1,206,110</b>	<b>942,747</b>	<b>299,799</b>	<b>111,184</b>	<b>35,419</b>	<b>17,690,744</b>	<b>535,820</b>	<b>18,226,563</b>
<b>Total Investments</b>	<b>9,183,632</b>	<b>347,288</b>	<b>2,828,489</b>	<b>2,564,958</b>	<b>379,891</b>	<b>12,400,534</b>	<b>11,230,264</b>	<b>604,395</b>	<b>4,226,150</b>	<b>43,765,601</b>	<b>270,815</b>	<b>44,036,415</b>
<b>Total Cash &amp; Investments</b>	<b>19,115,855</b>	<b>3,253,983</b>	<b>4,680,620</b>	<b>2,969,393</b>	<b>1,586,001</b>	<b>13,343,281</b>	<b>11,530,063</b>	<b>715,578</b>	<b>4,261,570</b>	<b>61,456,344</b>	<b>806,634</b>	<b>62,262,979</b>

Table 11: Historical Fund Balance (all funds)

Total Fund Balance	Jul	Aug	Sep	Oct	Nov	Dec	Jan	Feb	Mar	Apr	May	Jun
FY 2023-2024	64,396,672	66,853,692	77,646,041	75,255,318	69,614,743	67,027,657	66,960,685	64,399,760	61,456,344	-	-	-
FY 2022-2023	56,226,725	60,666,269	68,738,390	69,346,697	63,609,233	60,193,048	60,611,541	58,125,322	56,459,470	52,538,757	52,939,999	60,284,687
FY 2021-2022	54,664,996	53,716,676	58,203,136	63,374,492	58,934,118	57,213,855	58,024,520	58,512,930	56,398,456	53,304,392	52,808,385	58,668,575
FY 2020-2021	46,133,625	51,685,227	63,693,672	60,671,125	55,384,722	53,249,331	53,629,066	52,132,962	46,912,837	46,288,537	43,388,787	50,253,381

Chart 11: Historical Fund Balance (all funds)

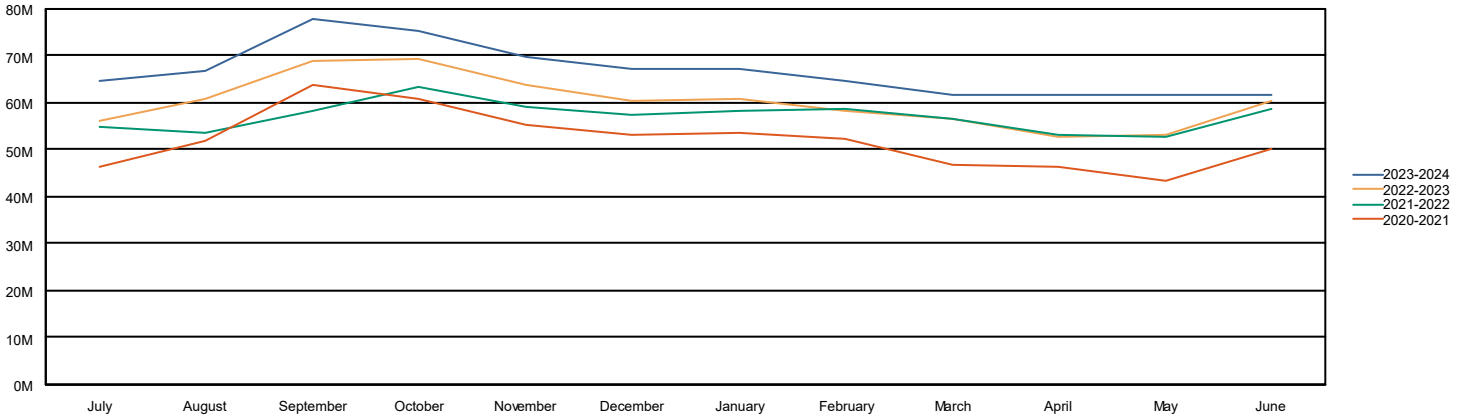

Table 12: Education Fund Fund Balance

Education Fund Balance	Jul	Aug	Sep	Oct	Nov	Dec	Jan	Feb	Mar	Apr	May	Jun
FY 2023-2024	18,610,948	19,840,972	25,469,674	25,112,777	23,502,089	21,794,940	22,444,424	21,069,136	19,115,855	-	-	-
FY 2022-2023	12,984,485	15,500,999	19,861,916	21,405,479	19,401,081	17,699,916	18,133,035	15,947,421	14,705,515	13,086,033	12,894,981	16,630,354
FY 2021-2022	13,545,310	12,519,104	14,479,427	18,539,351	17,520,842	16,169,386	17,582,562	15,737,544	14,256,451	12,692,753	12,042,247	13,671,673
FY 2020-2021	9,773,544	12,266,926	18,718,956	16,955,298	15,376,059	13,691,714	13,196,560	12,027,964	10,898,464	10,097,357	8,105,000	11,753,713

Chart 12: Education Fund Fund Balance

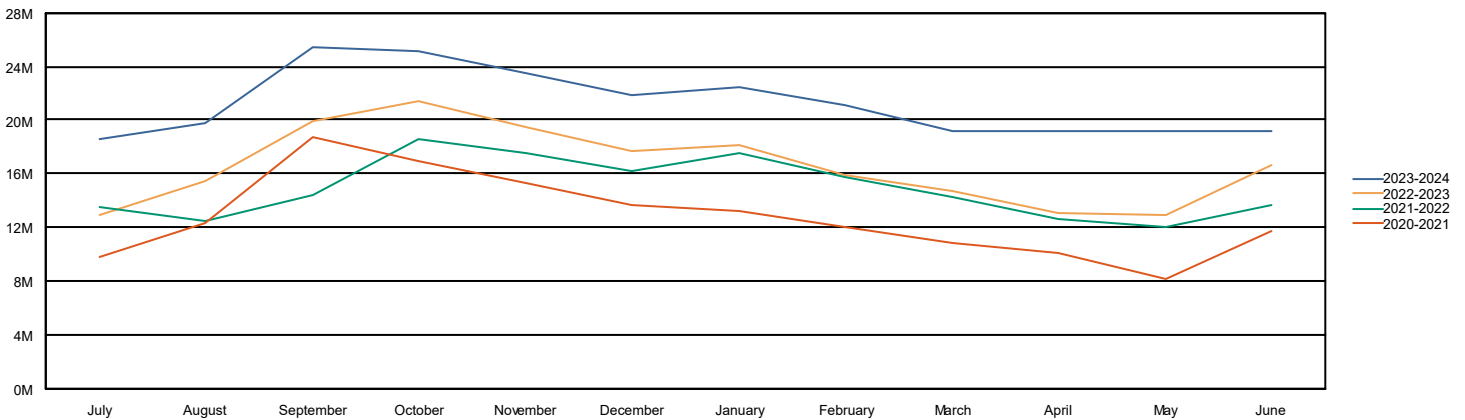

Table 13: Operations & Maint Fund Fund Balance

Operations & Maint Fund Balance	Jul	Aug	Sep	Oct	Nov	Dec	Jan	Feb	Mar	Apr	May	Jun
FY 2023-2024	3,711,337	3,717,183	4,751,877	4,722,234	4,130,083	3,815,236	3,544,591	3,281,422	3,253,983	-	-	-
FY 2022-2023	4,585,402	6,319,666	7,307,539	7,677,682	7,428,244	6,888,598	6,629,308	6,403,371	6,111,361	5,920,559	6,328,164	3,246,199
FY 2021-2022	5,310,410	5,245,008	5,670,229	6,546,693	6,344,108	6,569,792	6,299,224	5,999,020	5,679,385	5,425,342	5,510,661	5,915,245
FY 2020-2021	4,092,316	4,561,587	5,697,879	5,531,218	5,347,790	5,109,184	5,184,750	4,977,082	4,720,507	4,687,672	4,302,571	4,853,856

Chart 13: Operations & Maint Fund Fund Balance

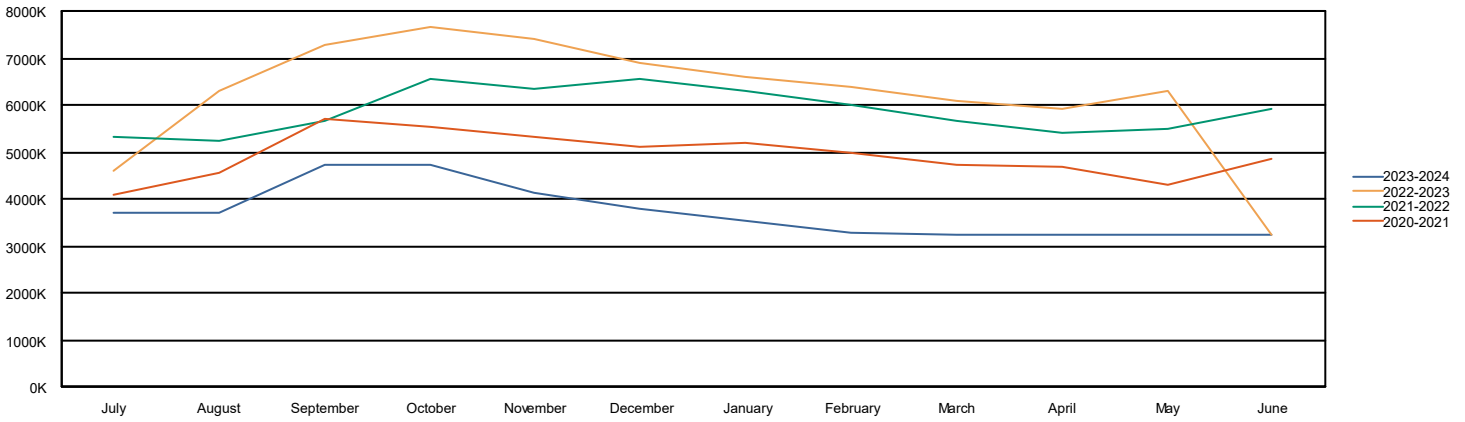

Table 14: Transportation Fund Fund Balance

Transportation Fund Balance	Jul	Aug	Sep	Oct	Nov	Dec	Jan	Feb	Mar	Apr	May	Jun
FY 2023-2024	2,426,041	2,649,225	3,164,731	3,404,112	3,198,921	3,014,615	3,265,199	3,139,521	2,969,393	-	-	-
FY 2022-2023	4,476,150	4,953,968	5,367,290	5,565,238	5,343,415	5,105,783	5,327,411	5,148,291	4,985,176	5,164,304	5,048,101	2,367,958
FY 2021-2022	4,986,229	4,794,301	4,909,083	5,419,930	5,251,598	5,086,340	5,178,897	4,973,216	4,754,917	4,789,435	4,679,735	4,783,863
FY 2020-2021	3,393,923	3,863,844	4,482,204	4,670,516	4,507,143	4,369,358	4,662,506	4,563,829	4,425,126	4,625,902	4,462,825	4,507,711

Chart 14: Transportation Fund Fund Balance

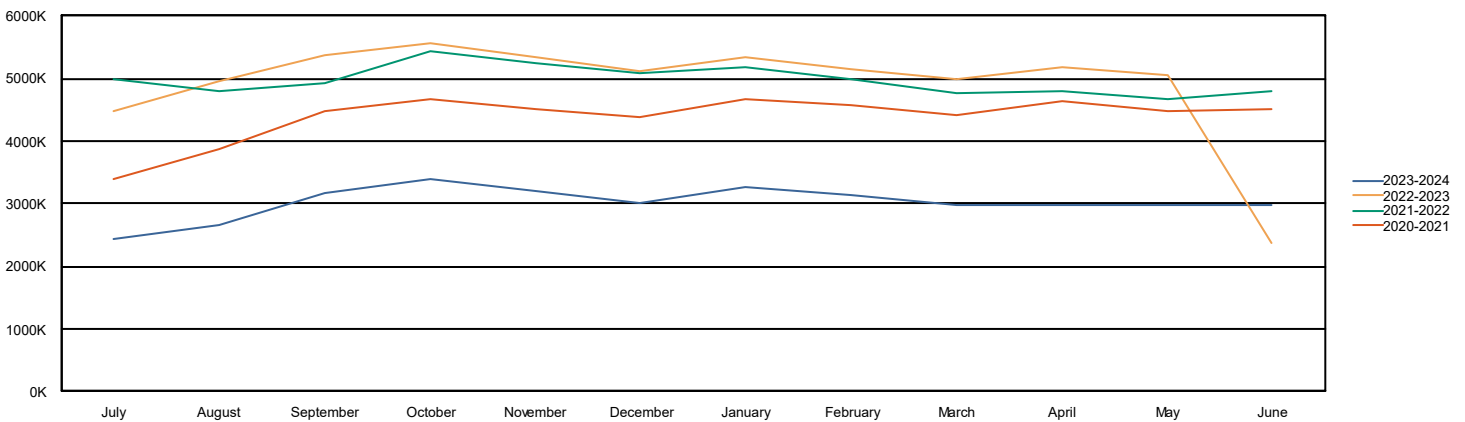
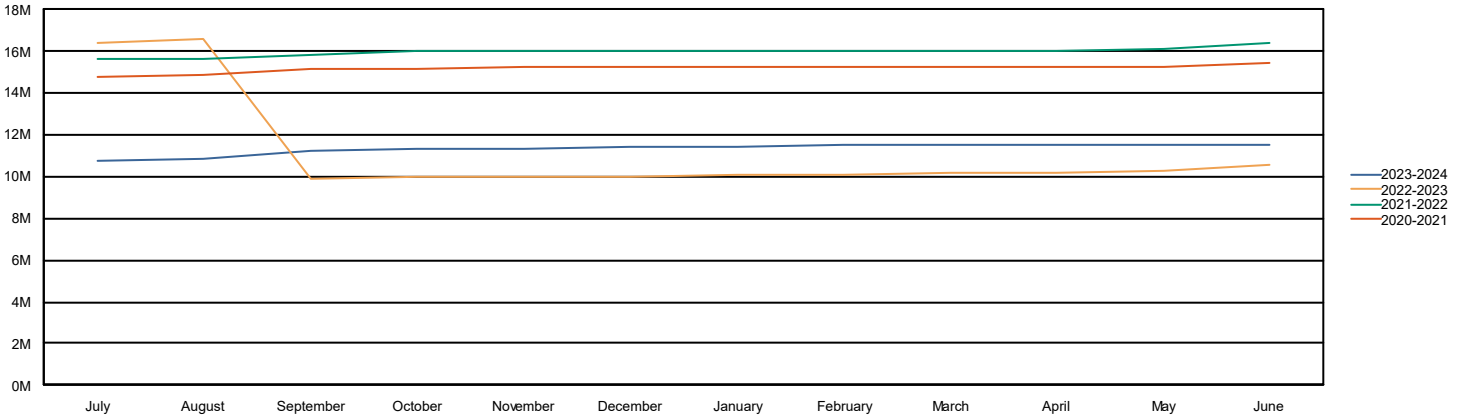

Table 15: Working Cash Fund Fund Balance

Working Cash Fund Balance	Jul	Aug	Sep	Oct	Nov	Dec	Jan	Feb	Mar	Apr	May	Jun
FY 2023-2024	10,738,024	10,868,823	11,212,468	11,288,916	11,347,954	11,391,599	11,432,756	11,472,507	11,530,063	-	-	-
FY 2022-2023	16,402,041	16,567,431	9,839,078	9,951,830	9,984,476	10,007,347	10,030,886	10,066,886	10,119,488	10,156,547	10,259,276	10,524,577
FY 2021-2022	15,594,578	15,631,321	15,763,868	15,983,343	16,011,675	16,033,009	16,035,262	16,035,464	16,036,253	16,038,551	16,085,435	16,340,895
FY 2020-2021	14,709,927	14,855,958	15,158,785	15,179,349	15,187,091	15,192,840	15,235,673	15,243,019	15,245,683	15,255,082	15,276,419	15,464,710

Chart 15: Working Cash Fund Fund Balance



### CONSUMER PRICE INDEX – FEBRUARY 2024

The Consumer Price Index for All Urban Consumers (CPI-U) increased 0.4 percent in February on a seasonally adjusted basis, after rising 0.3 percent in January, the U.S. Bureau of Labor Statistics reported today. Over the last 12 months, the all items index increased 3.2 percent before seasonal adjustment.

The index for shelter rose in February, as did the index for gasoline. Combined, these two indexes contributed over sixty percent of the monthly increase in the index for all items. The energy index rose 2.3 percent over the month, as all of its component indexes increased. The food index was unchanged in February, as was the food at home index. The food away from home index rose 0.1 percent over the month.

The index for all items less food and energy rose 0.4 percent in February, as it did in January. Indexes which increased in February include shelter, airline fares, motor vehicle insurance, apparel, and recreation. The index for personal care and the index for household furnishings and operations were among those that decreased over the month.

The all items index rose 3.2 percent for the 12 months ending February, a larger increase than the 3.1-percent increase for the 12 months ending January. The all items less food and energy index rose 3.8 percent over the last 12 months. The energy index decreased 1.9 percent for the 12 months ending February, while the food index increased 2.2 percent over the last year.

Chart 1. One-month percent change in CPI for All Urban Consumers (CPI-U), seasonally adjusted, Feb. 2023 - Feb. 2024

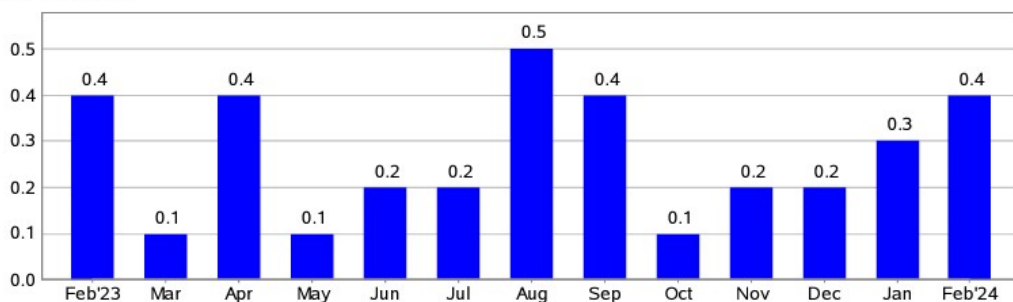
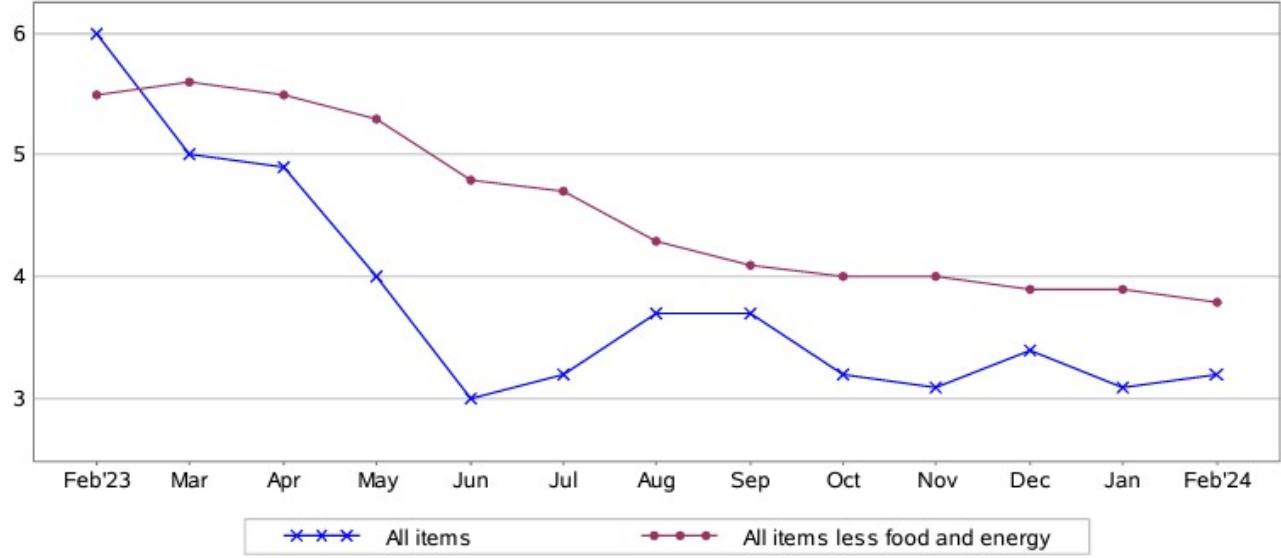

Chart 2. 12-month percent change in CPI for All Urban Consumers (CPI-U), not seasonally adjusted, Feb. 2023 - Feb. 2024  
Percent change



## Invoice Listing

COUNTY OF GRUNDY SCHOOL DIST 111

Vendor	PO Number	Invoice Number	Batch	Description	Invoice Date	Check Number	Net Amount	
Abdullah -Jones, Taura	1032400573	4/1 Volleyball Official	DFC	Boys Volleyball Official 4-1	04/01/2024	089014	114.00	
<b>Detail Description</b>				<b>Detail Account</b>		<b>Accounting Percent</b>		<b>Detail Amount</b>
Boys Volleyball Official 4-1				10 E 1500 3190 30 300 000009		100.0000%		114.00
<b>Total for Abdullah -Jones, Taura:</b>							<b>114.00</b>	
Abraham, Justin	1032400531	3/12 Baseball Official	DFC	Baseball official 3-12	03/12/2024	088989	72.00	
<b>Detail Description</b>				<b>Detail Account</b>		<b>Accounting Percent</b>		<b>Detail Amount</b>
Baseball official 3-12				10 E 1500 3190 30 300 000007		100.0000%		72.00
<b>Total for Abraham, Justin:</b>							<b>144.00</b>	
Abraham, Justin	1032400551	3/19 Baseball Official	DFC	Baseball Official 3-19	03/19/2024	089015	72.00	
<b>Detail Description</b>				<b>Detail Account</b>		<b>Accounting Percent</b>		<b>Detail Amount</b>
Baseball Official 3-19				10 E 1500 3190 30 300 000007		100.0000%		72.00
<b>Total for Abraham, Justin:</b>							<b>144.00</b>	
Alvarado, Alejandro	1032400557	3/23 Soccer Official	DFC	Girls Soccer Official 3-23	03/23/2024	089016	169.00	
<b>Detail Description</b>				<b>Detail Account</b>		<b>Accounting Percent</b>		<b>Detail Amount</b>
Girls Soccer Official 3-23				10 E 1500 3190 30 300 000012		100.0000%		169.00
<b>Total for Alvarado, Alejandro:</b>							<b>169.00</b>	
Alvey, Thane	1032400553	3/21 Baseball Official	DFC	Baseball Official 3-21	03/21/2024	089017	77.00	
<b>Detail Description</b>				<b>Detail Account</b>		<b>Accounting Percent</b>		<b>Detail Amount</b>
Baseball Official 3-21				10 E 1500 3190 30 300 000007		100.0000%		77.00
<b>Total for Alvey, Thane:</b>							<b>77.00</b>	
Cataudella, Frank	1032400535	3/13 Softball Official	DFC	Softball Official 3-13	03/13/2024	088990	77.00	
<b>Detail Description</b>				<b>Detail Account</b>		<b>Accounting Percent</b>		<b>Detail Amount</b>
Softball Official 3-13				10 E 1500 3190 30 300 000002		100.0000%		77.00
<b>Total for Cataudella, Frank:</b>							<b>77.00</b>	
CCC Holdings, Inc		Pay request 005	DFC	Admin Remodeling	03/13/2024	088991	417,075.77	
<b>Detail Description</b>				<b>Detail Account</b>		<b>Accounting Percent</b>		<b>Detail Amount</b>
Admin Remodeling				60 E 2535 3230 00 000 000000		100.0000%		417,075.77
<b>Total for CCC Holdings, Inc:</b>							<b>417,075.77</b>	
Cetera, Setphen	1032400562	3/20 Soccer Official	DFC	Girls Soccer Official 3-20	03/20/2024	089018	82.00	
<b>Detail Description</b>				<b>Detail Account</b>		<b>Accounting Percent</b>		<b>Detail Amount</b>
Girls Soccer Official 3-20				10 E 1500 3190 30 300 000012		100.0000%		82.00

## Invoice Listing

COUNTY OF GRUNDY SCHOOL DIST 111

Vendor	PO Number	Invoice Number	Batch	Description	Invoice Date	Check Number	Net Amount	
Cetera, Setphen	1032400565	3/25 Soccer Official	DFC	Girls Soccer Official 3-25	03/25/2024	089018	82.00	
<b>Detail Description</b>				<b>Detail Account</b>		<b>Accounting Percent</b>		<b>Detail Amount</b>
Girls Soccer Official 3-25				10 E 1500 3190 30 300 000012		100.0000%		82.00
<b>Total for Cetera, Setphen:</b>							<b>164.00</b>	
Chasing T's Inkooperated, LLC	2873		DFC	Tanks	05/10/2023	23582	1,157.00	
<b>Detail Description</b>				<b>Detail Account</b>		<b>Accounting Percent</b>		<b>Detail Amount</b>
Tanks				11 E 1999 4100 30 300 910012		100.0000%		1,157.00
<b>Total for Chasing T's Inkooperated, LLC:</b>							<b>1,157.00</b>	
Cook, Ashley R		Shoe Reimb	DFC	Shoe Reimb	03/18/2024	23583	446.54	
<b>Detail Description</b>				<b>Detail Account</b>		<b>Accounting Percent</b>		<b>Detail Amount</b>
Shoe Reimbursement				11 E 1999 4100 30 300 910012		100.0000%		446.54
<b>Total for Cook, Ashley R:</b>							<b>446.54</b>	
Crystal Lake Travel		0002012025	DFC	Transportation for UDA Nationals	01/28/2024	23587	7,915.40	
<b>Detail Description</b>				<b>Detail Account</b>		<b>Accounting Percent</b>		<b>Detail Amount</b>
Transportation for UDA Naitonals				11 E 1999 4100 30 300 910025		100.0000%		7,915.40
<b>Total for Crystal Lake Travel:</b>							<b>9,445.48</b>	
Crystal Lake Travel		0002012026	DFC	Resort Hotel Balance	01/28/2024	23587	1,530.08	
<b>Detail Description</b>				<b>Detail Account</b>		<b>Accounting Percent</b>		<b>Detail Amount</b>
Resort Hotel Balance				11 E 1999 4100 30 300 910025		100.0000%		1,530.08
<b>Total for Crystal Lake Travel:</b>							<b>9,445.48</b>	
Demaso, Arthur	1032400569	3/28 Baseball Official	DFC	Baseball Official 3-28	03/28/2024	089019	100.00	
<b>Detail Description</b>				<b>Detail Account</b>		<b>Accounting Percent</b>		<b>Detail Amount</b>
Baseball Official 3-28				10 E 1500 3190 30 300 000007		100.0000%		100.00
<b>Total for Demaso, Arthur:</b>							<b>100.00</b>	
Dieball, Kevin	1032400560	3/20 Volleyball Official	DFC	Boys Volleyball Official 3-20	04/20/2024	089020	124.00	
<b>Detail Description</b>				<b>Detail Account</b>		<b>Accounting Percent</b>		<b>Detail Amount</b>
Boys Volleyball Official 3-20				10 E 1500 3190 30 300 000009		100.0000%		124.00
<b>Total for Dieball, Kevin:</b>							<b>124.00</b>	
Dooley, Richard	1032400570	3/28 Baseball Official	DFC	Baseball Official 3-28	03/28/2024	089021	152.00	
<b>Detail Description</b>				<b>Detail Account</b>		<b>Accounting Percent</b>		<b>Detail Amount</b>
Lacrosse Official 3-28				10 E 1500 3190 30 300 000014		100.0000%		152.00
<b>Total for Dooley, Richard:</b>							<b>152.00</b>	

## Invoice Listing

COUNTY OF GRUNDY SCHOOL DIST 111

Vendor	PO Number	Invoice Number	Batch	Description	Invoice Date	Check Number	Net Amount	
Emmert, James	1032400545	3/15 Track Official	DFC	Boys Track Official 3-15	03/15/2024	088992	154.00	
<b>Detail Description</b>				<b>Detail Account</b>		<b>Accounting Percent</b>		<b>Detail Amount</b>
Boys Track Official 3-15				10 E 1500 3190 30 300 000011		100.0000%		154.00
<b>Total for Emmert, James:</b>							<b>154.00</b>	
Facko, Gary	1032400566	3/25 Soccer Official	DFC	Girls Soccer Official 3-25	03/25/2024	089022	82.00	
<b>Detail Description</b>				<b>Detail Account</b>		<b>Accounting Percent</b>		<b>Detail Amount</b>
Girls Soccer Official 3-25				10 E 1500 3190 30 300 000012		100.0000%		82.00
<b>Total for Facko, Gary:</b>							<b>82.00</b>	
Ferguson, Robert	1032400555	3/21 Softball Official	DFC	Softball Official 3-21	03/21/2024	089023	77.00	
<b>Detail Description</b>				<b>Detail Account</b>		<b>Accounting Percent</b>		<b>Detail Amount</b>
Softball Official 3-21				10 E 1500 3190 30 300 000002		100.0000%		77.00
<b>Total for Ferguson, Robert:</b>							<b>77.00</b>	
Gerkitz, Raymond	1032400561	3/20 Volleyball Official	DFC	Boys Volleyball Official 3-20	03/20/2024	089024	124.00	
<b>Detail Description</b>				<b>Detail Account</b>		<b>Accounting Percent</b>		<b>Detail Amount</b>
Boys Volleyball Official 3-20				10 E 1500 3190 30 300 000009		100.0000%		124.00
<b>Total for Gerkitz, Raymond:</b>							<b>124.00</b>	
Hamby, William	1032400563	3/20 Soccer Official	DFC	Girls Soccer Official 3-20	03/20/2024	089025	82.00	
<b>Detail Description</b>				<b>Detail Account</b>		<b>Accounting Percent</b>		<b>Detail Amount</b>
Girls Soccer Official 3-20				10 E 1500 3190 30 300 000012		100.0000%		82.00
<b>Total for Hamby, William:</b>							<b>82.00</b>	
Happy Daisy Art Studio		240228	DFC	Kids Paint Party	02/28/2024	23588	550.00	
<b>Detail Description</b>				<b>Detail Account</b>		<b>Accounting Percent</b>		<b>Detail Amount</b>
Kids Paint Party				11 E 1999 4100 70 300 900048		100.0000%		550.00
<b>Total for Happy Daisy Art Studio:</b>							<b>550.00</b>	
Harvey, Tyler	1032400530	3/12 Baseball Official	DFC	Baseball official 3-12	03/12/2024	088993	74.00	
<b>Detail Description</b>				<b>Detail Account</b>		<b>Accounting Percent</b>		<b>Detail Amount</b>
Baseball official 3-12				10 E 1500 3190 30 300 000007		100.0000%		74.00
<b>Total for Harvey, Tyler:</b>							<b>74.00</b>	
Hayen, Ray	1032400527	3/13 Softball Official	DFC	Softball Official - 3-13	03/13/2024	088994	77.00	
<b>Detail Description</b>				<b>Detail Account</b>		<b>Accounting Percent</b>		<b>Detail Amount</b>
Softball Official - 3-13				10 E 1500 3190 30 300 000002		100.0000%		77.00
<b>Total for Hayen, Ray:</b>							<b>77.00</b>	

## Invoice Listing

COUNTY OF GRUNDY SCHOOL DIST 111

Vendor	PO Number	Invoice Number	Batch	Description	Invoice Date	Check Number	Net Amount
Hug, Thomas	1032400528	3/13 Baseball Official	DFC	Baseball Official 3-13	03/13/2024	088995	77.00
<b>Detail Description</b>				<b>Detail Account</b>		<b>Accounting Percent</b>	<b>Detail Amount</b>
Baseball Official 3-13				10 E 1500 3190 30 300 000007		100.0000%	77.00
<b>Total for Hug, Thomas:</b>							<b>77.00</b>
IASC		2024 State Convention	DFC	2024 State Convention	03/20/2024	23584	690.00
<b>Detail Description</b>				<b>Detail Account</b>		<b>Accounting Percent</b>	<b>Detail Amount</b>
2024 State Convention				11 E 1999 4100 70 300 900048		100.0000%	690.00
<b>Total for IASC:</b>							<b>690.00</b>
Illinois Association of School Business Officials	0002400074	0050660	DFC	Individual School District Membership	03/21/2024	026548	835.00
<b>Detail Description</b>				<b>Detail Account</b>		<b>Accounting Percent</b>	<b>Detail Amount</b>
Individual School District Membership				10 E 2510 6400 00 300 000000		100.0000%	835.00
<b>Total for Illinois Association of School Business Officials:</b>							<b>835.00</b>
Illinois TSA		State Conference	DFC	State Conference	04/02/2024	23585	340.00
<b>Detail Description</b>				<b>Detail Account</b>		<b>Accounting Percent</b>	<b>Detail Amount</b>
State Conference				11 E 1999 4100 70 300 900049		100.0000%	340.00
<b>Total for Illinois TSA:</b>							<b>340.00</b>
IPA Three Rivers Region		2024 Student Breakfast	DFC	2024 IPA Three Rivers Region Student Recognition Celebration	03/21/2024	026549	210.00
<b>Detail Description</b>				<b>Detail Account</b>		<b>Accounting Percent</b>	<b>Detail Amount</b>
2024 IPA Three Rivers Region Student Recognition Celebration				10 E 2410 4100 00 300 000001		100.0000%	210.00
<b>Total for IPA Three Rivers Region:</b>							<b>210.00</b>
Jasionowski, Kevin	1032400529	3/13 Baseball Official	DFC	Baseball official 3-13	03/13/2024	088996	77.00
<b>Detail Description</b>				<b>Detail Account</b>		<b>Accounting Percent</b>	<b>Detail Amount</b>
Baseball official 3-13				10 E 1500 3190 30 300 000007		100.0000%	77.00
<b>Total for Jasionowski, Kevin:</b>							<b>77.00</b>
Johnson, Greg	1032400554	3/21 Baseball Official	DFC	Baseball Official 3-21	03/21/2024	089026	77.00
<b>Detail Description</b>				<b>Detail Account</b>		<b>Accounting Percent</b>	<b>Detail Amount</b>
Baseball Official 3-21				10 E 1500 3190 30 300 000007		100.0000%	77.00
<b>Total for Johnson, Greg:</b>							<b>77.00</b>

## Invoice Listing

COUNTY OF GRUNDY SCHOOL DIST 111

Vendor	PO Number	Invoice Number	Batch	Description	Invoice Date	Check Number	Net Amount
Johnson, Steven	1032400538	3/16 Track Official	DFC	Girls Track Official 3-16	03/16/2024	088997	154.00
<b>Detail Description</b>				<b>Detail Account</b>		<b>Accounting Percent</b>	<b>Detail Amount</b>
Girls Track Official 3-16				10 E 1500 3190 30 300 000010		100.0000%	154.00
<b>Total for Johnson, Steven:</b>							<b>154.00</b>
KaTom Restaurant Supply, Inc.	1062400020	631807	DFC	Fryer Oil dump station	04/03/2024	9100002309	2,807.68
<b>Detail Description</b>				<b>Detail Account</b>		<b>Accounting Percent</b>	<b>Detail Amount</b>
Fryer oil dump station				20 E 2540 4100 00 300 000000		100.0000%	2,807.68
KaTom Restaurant Supply, Inc.	1062400021	613807	DFC	Ice Machine for trainers office	04/03/2024	9100002309	7,106.59
<b>Detail Description</b>				<b>Detail Account</b>		<b>Accounting Percent</b>	<b>Detail Amount</b>
Ice Machine for Trainers office				20 E 2540 4100 00 300 000000		100.0000%	7,106.59
<b>Total for KaTom Restaurant Supply, Inc.:</b>							<b>9,914.27</b>
Kelly, Terry	1032400550	3/19 Baseball Official	DFC	Baseball Official 3-19	03/19/2024	089027	100.00
<b>Detail Description</b>				<b>Detail Account</b>		<b>Accounting Percent</b>	<b>Detail Amount</b>
Baseball Official 3-19				10 E 1500 3190 30 300 000007		100.0000%	100.00
<b>Total for Kelly, Terry:</b>							<b>100.00</b>
Mancilla, Jeremy	1032400534	3/15 Lacrosse Official	DFC	Boys Lacrosse Official 3-15	03/15/2024	088998	152.00
<b>Detail Description</b>				<b>Detail Account</b>		<b>Accounting Percent</b>	<b>Detail Amount</b>
Boys Lacrosse Official 3-15				10 E 1500 3190 30 300 000014		100.0000%	152.00
<b>Total for Mancilla, Jeremy:</b>							<b>152.00</b>
McKillip, Donald	1032400572	4/1 Volleyball Official	DFC	Boys Volleyball Official 4-1	04/01/2024	089028	114.00
<b>Detail Description</b>				<b>Detail Account</b>		<b>Accounting Percent</b>	<b>Detail Amount</b>
Boys Volleyball Official 4-1				10 E 1500 3190 30 300 000009		100.0000%	114.00
<b>Total for McKillip, Donald:</b>							<b>114.00</b>
O'Leary, Martin	1032400556	3/21 Softball Official	DFC	Softball Official 3-21	03/21/2024	089029	77.00
<b>Detail Description</b>				<b>Detail Account</b>		<b>Accounting Percent</b>	<b>Detail Amount</b>
Softball Official 3-21				10 E 1500 3190 30 300 000002		100.0000%	77.00
<b>Total for O'Leary, Martin:</b>							<b>77.00</b>
Pease, Christopher	1032400549	3/19 Soccer Official	DFC	Girls Soccer Official 3-19	03/19/2024	089030	82.00
<b>Detail Description</b>				<b>Detail Account</b>		<b>Accounting Percent</b>	<b>Detail Amount</b>
Girls Soccer Official 3-19				10 E 1500 3190 30 300 000012		100.0000%	82.00
<b>Total for Pease, Christopher:</b>							<b>82.00</b>

## Invoice Listing

COUNTY OF GRUNDY SCHOOL DIST 111

Vendor	PO Number	Invoice Number	Batch	Description	Invoice Date	Check Number	Net Amount
Pfeifer, Christian	1032400564	3/20 Soccer Official	DFC	Girls Soccer Official 3-20	03/20/2024	089031	82.00
<b>Detail Description</b>				<b>Detail Account</b>		<b>Accounting Percent</b>	<b>Detail Amount</b>
Girls Soccer Official 3-20				10 E 1500 3190 30 300 000012		100.0000%	82.00
<b>Total for Pfeifer, Christian:</b>							<b>82.00</b>
Pietrowiak, Russell	1032400558	3/23 Soccer Official	DFC	Girls Soccer Official 3-23	03/23/2024	089042	82.00
<b>Detail Description</b>				<b>Detail Account</b>		<b>Accounting Percent</b>	<b>Detail Amount</b>
Girls Soccer Official 3-23				10 E 1500 3190 30 300 000012		100.0000%	82.00
<b>Total for Pietrowiak, Russell:</b>							<b>82.00</b>
Plus 1 Designs LLC		SOW #006	DFC	Indoor Percussion Arrangement	02/28/2024	23589	1,500.00
<b>Detail Description</b>				<b>Detail Account</b>		<b>Accounting Percent</b>	<b>Detail Amount</b>
Indoor Percussion Arrangement				11 E 1999 4100 70 300 900041		100.0000%	1,500.00
<b>Total for Plus 1 Designs LLC:</b>							<b>1,500.00</b>
Reed-Custer High School	1152400087	IHSA Organizational Conte	DFC	IHSA Organizational Contest	03/09/2024	026550	175.00
<b>Detail Description</b>				<b>Detail Account</b>		<b>Accounting Percent</b>	<b>Detail Amount</b>
IHSA Organizational Contest Choir 1				10 E 1130 6400 12 300 000004		100.0000%	75.00
IHSA Organizational Contest Choir 2 and 3				10 E 1130 6400 12 300 000004		100.0000%	100.00
<b>Total for Reed-Custer High School:</b>							<b>175.00</b>
Rhode, James	1032400547	3/15 Track Official	DFC	Boys Track Official 3-15	03/15/2024	088999	154.00
<b>Detail Description</b>				<b>Detail Account</b>		<b>Accounting Percent</b>	<b>Detail Amount</b>
Boys Track Official 3-15				10 E 1500 3190 30 300 000011		100.0000%	154.00
<b>Total for Rhode, James:</b>							<b>154.00</b>
Riederer, Steven	1032400537	3/15 Track Official	DFC	Boys Track Official 3-15	03/15/2024	089000	154.00
<b>Detail Description</b>				<b>Detail Account</b>		<b>Accounting Percent</b>	<b>Detail Amount</b>
Boys Track Official 3-15				10 E 1500 3190 30 300 000011		100.0000%	154.00
Riederer, Steven	1032400540	3/16 Track Official	DFC	Girls Track Official 3-16	03/16/2024	089000	154.00
<b>Detail Description</b>				<b>Detail Account</b>		<b>Accounting Percent</b>	<b>Detail Amount</b>
Girls Track Official 3-16				10 E 1500 3190 30 300 000010		100.0000%	154.00
<b>Total for Riederer, Steven:</b>							<b>308.00</b>
Simpkins, Eugene	1032400536	3/18 Lacrosse Official	DFC	Girls lacrosse official 3-18	03/18/2024	089001	152.00
<b>Detail Description</b>				<b>Detail Account</b>		<b>Accounting Percent</b>	<b>Detail Amount</b>
Girls lacrosse official 3-18				10 E 1500 3190 30 300 000014		100.0000%	152.00
<b>Total for Simpkins, Eugene:</b>							<b>152.00</b>

## Invoice Listing

COUNTY OF GRUNDY SCHOOL DIST 111

Vendor	PO Number	Invoice Number	Batch	Description	Invoice Date	Check Number	Net Amount	
Snap! Mobile, Inc.		INV-501410	DFC	Subscription Fee	07/01/2023	026551	750.00	
<b>Detail Description</b>				<b>Detail Account</b>		<b>Accounting Percent</b>		<b>Detail Amount</b>
Subscription Fee				10 E 1500 4100 30 300 000017		100.0000%		750.00
<b>Total for Snap! Mobile, Inc.:</b>							<b>750.00</b>	
Story, Samuel	1032400571	3/15 Lacrosse Official	DFC	Lacrosse Official 3-15	03/15/2024	089032	152.00	
<b>Detail Description</b>				<b>Detail Account</b>		<b>Accounting Percent</b>		<b>Detail Amount</b>
Lacrosse Official 3-15				10 E 1500 3190 30 300 000014		100.0000%		152.00
<b>Total for Story, Samuel:</b>							<b>152.00</b>	
Struck, Peter	1032400539	3/15 Track Official	DFC	Boys Track Official 3-15	03/15/2024	089002	154.00	
<b>Detail Description</b>				<b>Detail Account</b>		<b>Accounting Percent</b>		<b>Detail Amount</b>
Boys Track Official 3-15				10 E 1500 3190 30 300 000011		100.0000%		154.00
<b>Total for Struck, Peter:</b>							<b>154.00</b>	
Valdez, Franklin	1032400526	3/13 Soccer Official	DFC	Girls Soccer official 3/14	03/13/2024	089003	72.00	
<b>Detail Description</b>				<b>Detail Account</b>		<b>Accounting Percent</b>		<b>Detail Amount</b>
Girls Soccer official 3/14				10 E 1500 3190 30 300 000012		100.0000%		72.00
<b>Total for Valdez, Franklin:</b>							<b>72.00</b>	
Verizon Wireless		9953155700	DFC	December Services	04/03/2024	089033	512.62	
<b>Detail Description</b>				<b>Detail Account</b>		<b>Accounting Percent</b>		<b>Detail Amount</b>
January Services				20 E 2540 3400 00 300 000001		100.0000%		512.62
<b>Total for Verizon Wireless:</b>							<b>512.62</b>	
Vinton, William	1032400548	3/19 Soccer Official	DFC	Girls Soccer Official 3-19	03/19/2024	089004	82.00	
<b>Detail Description</b>				<b>Detail Account</b>		<b>Accounting Percent</b>		<b>Detail Amount</b>
Girls Soccer Official 3-19				10 E 1500 3190 30 300 000012		100.0000%		82.00
<b>Total for Vinton, William:</b>							<b>82.00</b>	
Vorreyer, Jeffrey	1032400544	3/16 Track Official	DFC	Girls Track Official 3-16	03/16/2024	089005	154.00	
<b>Detail Description</b>				<b>Detail Account</b>		<b>Accounting Percent</b>		<b>Detail Amount</b>
Girls Track Official 3-16				10 E 1500 3190 30 300 000010		100.0000%		154.00
<b>Total for Vorreyer, Jeffrey:</b>							<b>154.00</b>	
Waecker, Steven	1032400559	3/23 Soccer Official	DFC	Girls Soccer Official 3-23	03/23/2024	089034	82.00	
<b>Detail Description</b>				<b>Detail Account</b>		<b>Accounting Percent</b>		<b>Detail Amount</b>
Girls Soccer Official 3-23				10 E 1500 3190 30 300 000012		100.0000%		82.00
<b>Total for Waecker, Steven:</b>							<b>82.00</b>	

## Invoice Listing

COUNTY OF GRUNDY SCHOOL DIST 111

Vendor	PO Number	Invoice Number	Batch	Description	Invoice Date	Check Number	Net Amount
Walker, Kellen J	1032400532	3/12 Baseball Official	DFC	Baseball official 3-12	03/12/2024	089006	72.00
<b>Detail Description</b>				<b>Detail Account</b>	<b>Accounting Percent</b>		<b>Detail Amount</b>
Baseball official 3-12				10 E 1500 3190 30 300 000007	100.0000%		72.00
<b>Total for Walker, Kellen J:</b>							<b>72.00</b>
Zein, Marwan	1032400567	3/25 Soccer Official	DFC	Girls Soccer Official 3-25	04/25/2024	089035	82.00
<b>Detail Description</b>				<b>Detail Account</b>	<b>Accounting Percent</b>		<b>Detail Amount</b>
Girls Soccer Official 3-25				10 E 1500 3190 30 300 000012	100.0000%		82.00
<b>Total for Zein, Marwan:</b>							<b>82.00</b>

### REPORT

<b>Total Number of Batch Invoices:</b>	0	0.00
<b>Total Number of Open Invoices:</b>	0	0.00
<b>Total Number of History Invoices:</b>	57	447,930.68
<b>Total Number of Update in Progress Batch Invoices:</b>	0	0.00
<b>Total Number of Update in Progress Batch Reversal Invoices:</b>	0	0.00
<b>Total Number of Reversal History Invoices:</b>	0	0.00
<b>Total Number of Deleted History Invoices:</b>	0	50.00
<b>Total Number of Batch Reversal Invoices:</b>	0	0.00
<b>Total Number of Unsubmitted Invoices:</b>	0	0.00
<b>Total Number of Awaiting for Approval Invoices:</b>	0	0.00
<b>Total Invoices:</b>	<b>57</b>	<b>447,930.68</b>

## Invoice Listing

COUNTY OF GRUNDY SCHOOL DIST 111

Vendor	PO Number	Invoice Number	Batch	Description	Invoice Date	Check Number	Net Amount
4N6 Fanatics		1150-6R-2024	DFC	4N6 Subscription	04/02/2024	9100002310	200.00
<b>Detail Description</b>		<b>Detail Account</b>		<b>Accounting Percent</b>		<b>Detail Amount</b>	
4N Subscription		10 E 1500 6400 70 300 000002		100.0000%		200.00	
<b>Total for 4N6 Fanatics:</b>							<b>200.00</b>
Acacia Academy		45119	DFC	Tuition	02/29/2024	089043	3,796.20
<b>Detail Description</b>		<b>Detail Account</b>		<b>Accounting Percent</b>		<b>Detail Amount</b>	
Tuition		10 E 1912 6700 00 300 000000		100.0000%		3,796.20	
<b>Total for Acacia Academy:</b>							<b>3,796.20</b>
Advertising Solutions		9161	DFC	Tumblers	04/01/2024	089044	300.00
<b>Detail Description</b>		<b>Detail Account</b>		<b>Accounting Percent</b>		<b>Detail Amount</b>	
Tumblers		10 E 1500 4100 70 300 000066		100.0000%		300.00	
<b>Total for Advertising Solutions:</b>							<b>300.00</b>
Albertsons / Safeway		724956-021324-3730	DFC	Water	02/13/2024	089045	45.37
<b>Detail Description</b>		<b>Detail Account</b>		<b>Accounting Percent</b>		<b>Detail Amount</b>	
Water		10 E 2310 4100 00 300 000000		100.0000%		45.37	
Albertsons / Safeway		727333-040224-3730	DFC	Connection Crew Supplies	04/02/2024	089045	54.99
<b>Detail Description</b>		<b>Detail Account</b>		<b>Accounting Percent</b>		<b>Detail Amount</b>	
Supplies		10 E 1500 4100 70 300 000066		100.0000%		4.99	
Albertsons / Safeway		727787-031224-3730	DFC	SAT Testing Supplies	03/12/2024	089045	51.72
<b>Detail Description</b>		<b>Detail Account</b>		<b>Accounting Percent</b>		<b>Detail Amount</b>	
SAT Testing Supplies		10 E 1130 4100 00 300 000002		100.0000%		51.72	
Albertsons / Safeway		728349-031324-3730	DFC	Connection Crew Supplies	03/13/2024	089045	88.13
<b>Detail Description</b>		<b>Detail Account</b>		<b>Accounting Percent</b>		<b>Detail Amount</b>	
Supplies		10 E 1500 4100 70 300 000066		100.0000%		88.13	
Albertsons / Safeway		802738-032224-3730	DFC	Water	03/22/2024	089045	38.87
<b>Detail Description</b>		<b>Detail Account</b>		<b>Accounting Percent</b>		<b>Detail Amount</b>	
Water		10 E 2310 4100 00 300 000000		100.0000%		38.87	
Albertsons / Safeway		809059-030424-3730	DFC	Water	03/04/2024	089045	135.00
<b>Detail Description</b>		<b>Detail Account</b>		<b>Accounting Percent</b>		<b>Detail Amount</b>	
Water		10 E 2310 4100 00 300 000000		100.0000%		135.00	
Albertsons / Safeway	1092400021	430362-031324-3730	DFC	Jewel Open PO	03/13/2024	089045	50.69
<b>Detail Description</b>		<b>Detail Account</b>		<b>Accounting Percent</b>		<b>Detail Amount</b>	
Jewel Open PO		10 E 1420 4100 09 300 000000		100.0000%		50.69	

## Invoice Listing

COUNTY OF GRUNDY SCHOOL DIST 111

Vendor	PO Number	Invoice Number	Batch	Description	Invoice Date	Check Number	Net Amount
Albertsons / Safeway	1092400021	433308-040324-3730	DFC	Jewel Open PO	04/03/2024	089045	87.84
<b>Detail Description</b>				<b>Detail Account</b>		<b>Accounting Percent</b>	<b>Detail Amount</b>
Jewel Open PO				10 E 1420 4100 09 300 000000		100.0000%	87.84
Albertsons / Safeway	1092400021	435357-020724-3730	DFC	Jewel Open PO	02/07/2024	089045	156.44
<b>Detail Description</b>				<b>Detail Account</b>		<b>Accounting Percent</b>	<b>Detail Amount</b>
Jewel Open PO				10 E 1420 4100 09 300 000000		100.0000%	156.44
Albertsons / Safeway	1092400021	436142-021324-3730	DFC	Jewel Open PO	02/13/2024	089045	73.96
<b>Detail Description</b>				<b>Detail Account</b>		<b>Accounting Percent</b>	<b>Detail Amount</b>
Jewel Open PO				10 E 1420 4100 09 300 000000		100.0000%	73.96
Albertsons / Safeway	1092400021	436795-021624-3730	DFC	Jewel Open PO	02/16/2024	089045	59.70
<b>Detail Description</b>				<b>Detail Account</b>		<b>Accounting Percent</b>	<b>Detail Amount</b>
Jewel Open PO				10 E 1420 4100 09 300 000000		100.0000%	59.70
Albertsons / Safeway	1092400021	437342-022124-3730	DFC	Jewel Open PO	02/21/2024	089045	51.39
<b>Detail Description</b>				<b>Detail Account</b>		<b>Accounting Percent</b>	<b>Detail Amount</b>
Jewel Open PO				10 E 1420 4100 09 300 000000		100.0000%	51.39
Albertsons / Safeway	1092400021	437943-022624-3730	DFC	Jewel Open PO	02/26/2024	089045	111.80
<b>Detail Description</b>				<b>Detail Account</b>		<b>Accounting Percent</b>	<b>Detail Amount</b>
Jewel Open PO				10 E 1420 4100 09 300 000000		100.0000%	111.80
Albertsons / Safeway	1092400021	438840-030424-3730	DFC	Jewel Open PO	03/04/2024	089045	260.07
<b>Detail Description</b>				<b>Detail Account</b>		<b>Accounting Percent</b>	<b>Detail Amount</b>
Jewel Open PO				10 E 1420 4100 09 300 000000		100.0000%	260.07
Albertsons / Safeway	1092400021	43991-031124-3730	DFC	Jewel Open PO	03/11/2024	089045	25.14
<b>Detail Description</b>				<b>Detail Account</b>		<b>Accounting Percent</b>	<b>Detail Amount</b>
Jewel Open PO				10 E 1420 4100 09 300 000000		100.0000%	25.14
Albertsons / Safeway	1092400021	666651-021524-3730	DFC	Jewel Open PO	02/15/2024	089045	20.15
<b>Detail Description</b>				<b>Detail Account</b>		<b>Accounting Percent</b>	<b>Detail Amount</b>
Jewel Open PO				10 E 1420 4100 09 300 000000		100.0000%	20.15
Albertsons / Safeway	1092400021	666727-021524-3730	DFC	Jewel Open PO	02/15/2024	089045	100.85
<b>Detail Description</b>				<b>Detail Account</b>		<b>Accounting Percent</b>	<b>Detail Amount</b>
Jewel Open PO				10 E 1420 4100 09 300 000000		100.0000%	100.85
Albertsons / Safeway	1092400021	667411-022124-3730	DFC	Jewel Open PO	02/21/2024	089045	50.89
<b>Detail Description</b>				<b>Detail Account</b>		<b>Accounting Percent</b>	<b>Detail Amount</b>
Jewel Open PO				10 E 1420 4100 09 300 000000		100.0000%	50.89

## Invoice Listing

COUNTY OF GRUNDY SCHOOL DIST 111

Vendor	PO Number	Invoice Number	Batch	Description	Invoice Date	Check Number	Net Amount
Albertsons / Safeway	1092400021	667512-022224-3730	DFC	Jewel Open PO	02/22/2024	089045	29.25
<b>Detail Description</b>				<b>Detail Account</b>		<b>Accounting Percent</b>	<b>Detail Amount</b>
Jewel Open PO				10 E 1420 4100 09 300 000000		100.0000%	29.25
Albertsons / Safeway	1092400021	669340-030624-3730	DFC	Jewel Open PO	03/06/2024	089045	57.24
<b>Detail Description</b>				<b>Detail Account</b>		<b>Accounting Percent</b>	<b>Detail Amount</b>
Jewel Open PO				10 E 1420 4100 09 300 000000		100.0000%	57.24
Albertsons / Safeway	1092400021	669538-030724-3730	DFC	Jewel Open PO	03/07/2024	089045	341.75
<b>Detail Description</b>				<b>Detail Account</b>		<b>Accounting Percent</b>	<b>Detail Amount</b>
Jewel Open PO				10 E 1420 4100 09 300 000000		100.0000%	341.75
Albertsons / Safeway	1092400021	669739-030824-3730	DFC	Jewel Open PO	03/08/2024	089045	165.40
<b>Detail Description</b>				<b>Detail Account</b>		<b>Accounting Percent</b>	<b>Detail Amount</b>
Jewel Open PO				10 E 1420 4100 09 300 000000		100.0000%	165.40
Albertsons / Safeway	1092400021	722070-020724-3730	DFC	Jewel Open PO	02/07/2024	089045	128.61
<b>Detail Description</b>				<b>Detail Account</b>		<b>Accounting Percent</b>	<b>Detail Amount</b>
Jewel Open PO				10 E 1420 4100 09 300 000000		100.0000%	128.61
Albertsons / Safeway	1092400021	722178-022824-3730	DFC	Jewel Open PO	02/28/2024	089045	52.41
<b>Detail Description</b>				<b>Detail Account</b>		<b>Accounting Percent</b>	<b>Detail Amount</b>
Jewel Open PO				10 E 1420 4100 09 300 000000		100.0000%	52.41
Albertsons / Safeway	1092400021	723347-020924-3730	DFC	Jewel Open PO	02/09/2024	089045	31.03
<b>Detail Description</b>				<b>Detail Account</b>		<b>Accounting Percent</b>	<b>Detail Amount</b>
Jewel Open PO				10 E 1420 4100 09 300 000000		100.0000%	31.03
Albertsons / Safeway	1092400021	724288-030424-3730	DFC	Jewel Open PO	03/04/2024	089045	168.10
<b>Detail Description</b>				<b>Detail Account</b>		<b>Accounting Percent</b>	<b>Detail Amount</b>
Jewel Open PO				10 E 1420 4100 09 300 000000		100.0000%	168.10
Albertsons / Safeway	1092400021	725617-021424-3730	DFC	Jewel Open PO	02/14/2024	089045	126.45
<b>Detail Description</b>				<b>Detail Account</b>		<b>Accounting Percent</b>	<b>Detail Amount</b>
Jewel Open PO				10 E 1420 4100 09 300 000000		100.0000%	126.45
Albertsons / Safeway	1092400021	725925-030724-3730	DFC	Jewel Open PO	03/07/2024	089045	73.95
<b>Detail Description</b>				<b>Detail Account</b>		<b>Accounting Percent</b>	<b>Detail Amount</b>
Jewel Open PO				10 E 1420 4100 09 300 000000		100.0000%	73.95
Albertsons / Safeway	1092400021	726119-021524-3730	DFC	Jewel Open PO	02/15/2024	089045	94.36
<b>Detail Description</b>				<b>Detail Account</b>		<b>Accounting Percent</b>	<b>Detail Amount</b>
Jewel Open PO				10 E 1420 4100 09 300 000000		100.0000%	94.36

## Invoice Listing

COUNTY OF GRUNDY SCHOOL DIST 111

Vendor	PO Number	Invoice Number	Batch	Description	Invoice Date	Check Number	Net Amount
Albertsons / Safeway	1092400021	727381-040224-3730	DFC	Jewel Open PO	04/02/2024	089045	126.99
<b>Detail Description</b>				<b>Detail Account</b>		<b>Accounting Percent</b>	<b>Detail Amount</b>
Jewel Open PO				10 E 1420 4100 09 300 000000		100.0000%	126.99
Albertsons / Safeway	1092400021	727438-040224-3730	DFC	Jewel Open PO	04/02/2024	089045	126.10
<b>Detail Description</b>				<b>Detail Account</b>		<b>Accounting Percent</b>	<b>Detail Amount</b>
Jewel Open PO				10 E 1420 4100 09 300 000000		100.0000%	126.10
Albertsons / Safeway	1092400021	728975-040524-3730	DFC	Jewel Open PO	04/05/2024	089045	95.36
<b>Detail Description</b>				<b>Detail Account</b>		<b>Accounting Percent</b>	<b>Detail Amount</b>
Jewel Open PO				10 E 1420 4100 09 300 000000		100.0000%	95.36
Albertsons / Safeway	1092400021	800222-031224-3730	DFC	Jewel Open PO	03/12/2024	089045	64.80
<b>Detail Description</b>				<b>Detail Account</b>		<b>Accounting Percent</b>	<b>Detail Amount</b>
Jewel Open PO				10 E 1420 4100 09 300 000000		100.0000%	64.80
Albertsons / Safeway	1092400021	801347-031924-3730	DFC	Jewel Open PO	03/19/2024	089045	26.24
<b>Detail Description</b>				<b>Detail Account</b>		<b>Accounting Percent</b>	<b>Detail Amount</b>
Jewel Open PO				10 E 1420 4100 09 300 000000		100.0000%	26.24
Albertsons / Safeway	1092400021	801440/032024-3730	DFC	Jewel Open PO	03/20/2024	089045	<del>47.98</del>
<b>Detail Description</b>				<b>Detail Account</b>		<b>Accounting Percent</b>	<b>Detail Amount</b>
Jewel Open PO				10 E 1420 4100 09 300 000000		100.0000%	47.98
Albertsons / Safeway	1092400021	801545-032024-3730	DFC	Jewel Open PO	03/20/2024	089045	74.27
<b>Detail Description</b>				<b>Detail Account</b>		<b>Accounting Percent</b>	<b>Detail Amount</b>
Jewel Open PO				10 E 1420 4100 09 300 000000		100.0000%	74.27
Albertsons / Safeway	1092400021	801891-032224-3730	DFC	Jewel Open PO	03/22/2024	089045	4.79
<b>Detail Description</b>				<b>Detail Account</b>		<b>Accounting Percent</b>	<b>Detail Amount</b>
Jewel Open PO				10 E 1420 4100 09 300 000000		100.0000%	4.79
Albertsons / Safeway	1092400021	802398-032124-3730	DFC	Jewel Open PO	03/21/2024	089045	114.79
<b>Detail Description</b>				<b>Detail Account</b>		<b>Accounting Percent</b>	<b>Detail Amount</b>
Jewel Open PO				10 E 1420 4100 09 300 000000		100.0000%	114.79
Albertsons / Safeway	1092400021	802876-020824-3730	DFC	Jewel Open PO	02/08/2024	089045	48.43
<b>Detail Description</b>				<b>Detail Account</b>		<b>Accounting Percent</b>	<b>Detail Amount</b>
Jewel Open PO				10 E 1420 4100 09 300 000000		100.0000%	48.43
Albertsons / Safeway	1092400021	805644-021424-3730	DFC	Jewel Open PO	02/14/2024	089045	91.69
<b>Detail Description</b>				<b>Detail Account</b>		<b>Accounting Percent</b>	<b>Detail Amount</b>
Jewel Open PO				10 E 1420 4100 09 300 000000		100.0000%	91.69

## Invoice Listing

COUNTY OF GRUNDY SCHOOL DIST 111

Vendor	PO Number	Invoice Number	Batch	Description	Invoice Date	Check Number	Net Amount
Albertsons / Safeway	1092400021	805671-020824-3730	DFC	Jewel Open PO	02/08/2024	089045	74.95
<b>Detail Description</b>				<b>Detail Account</b>		<b>Accounting Percent</b>	<b>Detail Amount</b>
Jewel Open PO				10 E 1420 4100 09 300 000000		100.0000%	74.95
Albertsons / Safeway	1092400021	806345-030824-3730	DFC	Jewel Open PO	03/08/2024	089045	20.86
<b>Detail Description</b>				<b>Detail Account</b>		<b>Accounting Percent</b>	<b>Detail Amount</b>
Jewel Open PO				10 E 1420 4100 09 300 000000		100.0000%	20.86
Albertsons / Safeway	1092400021	807855-022024-3730	DFC	Jewel Open PO	02/20/2024	089045	134.64
<b>Detail Description</b>				<b>Detail Account</b>		<b>Accounting Percent</b>	<b>Detail Amount</b>
Jewel Open PO				10 E 1420 4100 09 300 000000		100.0000%	134.64
Albertsons / Safeway	1092400021	808336-031324-3730	DFC	Jewel Open PO	03/13/2024	089045	222.69
<b>Detail Description</b>				<b>Detail Account</b>		<b>Accounting Percent</b>	<b>Detail Amount</b>
Jewel Open PO				10 E 1420 4100 09 300 000000		100.0000%	222.69
Albertsons / Safeway	1092400021	808594-022924-3730	DFC	Jewel Open PO	02/29/2024	089045	48.47
<b>Detail Description</b>				<b>Detail Account</b>		<b>Accounting Percent</b>	<b>Detail Amount</b>
Jewel Open PO				10 E 1420 4100 09 300 000000		100.0000%	48.47
<b>Total for Albertsons / Safeway:</b>							<b>4,064.60</b>
All Star Custom Awards	1032400533	6696	DFC	SPC Girls Indoor Track Awards	03/13/2024	9100002311	1,020.00
<b>Detail Description</b>				<b>Detail Account</b>		<b>Accounting Percent</b>	<b>Detail Amount</b>
SPC Girls Indoor Track Awards				10 E 1500 4100 30 300 000021		100.0000%	1,020.00
<b>Total for All Star Custom Awards:</b>							<b>1,020.00</b>
Amazon Capital Services, Inc.		1HVY-CC14-6DKK	DFC	Promotions & Discounts	03/26/2024	9100002312	-4.80
<b>Detail Description</b>				<b>Detail Account</b>		<b>Accounting Percent</b>	<b>Detail Amount</b>
Promotions & Discounts				10 E 1130 4100 00 300 000000		100.0000%	-4.80
Amazon Capital Services, Inc.		1P7K-FJ13-16JD	DFC	Promotions & Discounts	03/19/2024	9100002312	-90.01
<b>Detail Description</b>				<b>Detail Account</b>		<b>Accounting Percent</b>	<b>Detail Amount</b>
Promotions & Discounts				10 E 1130 4100 00 300 000000		100.0000%	-90.01
Amazon Capital Services, Inc.	0002400110	1NRD-KFGN-XK91	DFC	Electric Meter Safety Tags	03/12/2024	9100002312	17.98
<b>Detail Description</b>				<b>Detail Account</b>		<b>Accounting Percent</b>	<b>Detail Amount</b>
Electric Meter Security Seal Wire Padlock Pack of 50 (Red)				20 E 2540 4100 00 302 000000		100.0000%	12.99
Cost of shipping, not including shipping tax.				20 E 2540 4100 00 302 000000		100.0000%	4.99

## Invoice Listing

COUNTY OF GRUNDY SCHOOL DIST 111

Vendor	PO Number	Invoice Number	Batch	Description	Invoice Date	Check Number	Net Amount
Amazon Capital Services, Inc.	0002400111	1NRD-KFGN-XK91	DFC	Gas Hose	03/12/2024	9100002312	235.38
<b>Detail Description</b>		<b>Detail Account</b>		<b>Accounting Percent</b>		<b>Detail Amount</b>	
DORMONT Swivel Max 1 1/4" NPT Fitting S125		10 E 2560 3230 00 300 000000		100.0000%		235.38	
Amazon Capital Services, Inc.	0002400112	1P7K-FJ13-16JD	DFC	Gas Line Swivel	03/19/2024	9100002312	211.76
<b>Detail Description</b>		<b>Detail Account</b>		<b>Accounting Percent</b>		<b>Detail Amount</b>	
Dormont SM125 Swivel Max, 1-1/4 Inch		20 E 2540 4100 00 302 000000		100.0000%		211.76	
Amazon Capital Services, Inc.	0002400119	1HVY-CC14-6DKK	DFC	Replacement Light Bulbs	03/26/2024	9100002312	32.20
<b>Detail Description</b>		<b>Detail Account</b>		<b>Accounting Percent</b>		<b>Detail Amount</b>	
OCS Parts Hatco 02.30.043.00 Replacement Light Bulbs   60W E25 Torpedo Shape Replacement Lamps for Hatco Food Warmers (10-Pack)		20 E 2540 4100 00 302 000000		100.0000%		32.20	
Amazon Capital Services, Inc.	0002400120	1HVY-CC14-6DKK	DFC	Water Fountain and Filter	03/26/2024	9100002312	1,732.99
<b>Detail Description</b>		<b>Detail Account</b>		<b>Accounting Percent</b>		<b>Detail Amount</b>	
Halsey Taylor HTHB-HAC8BL-NF HydroBoost Wall Mounted Bi-Level Indoor Water, Platinum Vinyl		20 E 2540 4100 00 302 000000		100.0000%		1,732.99	
Amazon Capital Services, Inc.	0002400120	1KFK-NGVX-7T1X	DFC	Water Fountain and Filter	04/02/2024	9100002312	102.65
<b>Detail Description</b>		<b>Detail Account</b>		<b>Accounting Percent</b>		<b>Detail Amount</b>	
Halsey Taylor HWF3000 WaterSentry Plus Filter Kit (Bottle Fillers)		20 E 2540 4100 00 302 000000		100.0000%		91.65	
Cost of shipping, not including shipping tax.		20 E 2540 4100 00 302 000000		100.0000%		11.00	
Amazon Capital Services, Inc.	1002400018	1NRD-KFGN-XK91	DFC	Bluetooth headset	03/12/2024	9100002312	39.99
<b>Detail Description</b>		<b>Detail Account</b>		<b>Accounting Percent</b>		<b>Detail Amount</b>	
FIMITECH Bluetooth Headset, Wireless Earpiece V5.0 Bluetooth Earpiece Ultralight Hands Free for Business/Office/Driving/Sporting		10 E 2410 4100 00 300 000000		100.0000%		39.99	

## Invoice Listing

COUNTY OF GRUNDY SCHOOL DIST 111

Vendor	PO Number	Invoice Number	Batch	Description	Invoice Date	Check Number	Net Amount
Amazon Capital Services, Inc.	1012400014	1PNC-JGCP-W4N7	DFC	South Campus Library Supplies	04/09/2024	9100002312	214.25

Detail Description	Detail Account	Accounting Percent	Detail Amount
Pressman PRE-3018-06J Mastermind Strategy Game of Codemaker vs. Codebreaker, 5", Multi-colored	10 E 2222 4100 00 300 000000	100.0000%	17.99
Elmer's All Purpose School Glue Sticks, Washable, 7 Grams, 30 Count	10 E 2222 4100 00 300 000000	100.0000%	7.37
Business Source 32953 Invisible Tape Value Pk, 1-Inch Core, 3/4-Inch x1000-Inch , 12/PK, Clear	10 E 2222 4100 00 300 000000	100.0000%	12.09
Clorox Disinfecting Wipes Value Pack, Household Essentials, 75 Count (Pack of 3)(Package May Vary)	10 E 2222 4100 00 300 000000	100.0000%	12.47
SKKSTATIONERY Pre-sharpened pencils, Pencils Sharpened with eraser top, 2 HB pencil, 144/box.	10 E 2222 4100 00 300 000000	100.0000%	16.39
Prompta 400 Conversation Cards for Friends – Casual, Funny Get to Know You Conversation Starters to Connect with Friends	10 E 2222 4100 00 300 000000	100.0000%	24.99
20 Pieces Japanese Chinese Lanterns Decoration Includes 6 Cherry Flowers Japanese Paper Lanterns 14 Chinese Red Lanterns 12 Inch Cherry Blossom Lanterns Home Decor for New Year (White)	10 E 2222 4100 00 300 000000	100.0000%	18.99
52 Pcs Ramadan Mubarak Decorations Arabian Nights Party Decoration Eid Mubarak Hanging Swirls Ceiling Foil Party Decoration for Indian Moroccan Princess Birthday Supplies	10 E 2222 4100 00 300 000000	100.0000%	60
3 Pieces Purple and Gold Tablecloth Nights Tablecover Purple Plastic Tablecloth Purple and Gold Birthday Party Nights Decorations Supplies	10 E 2222 4100 00 300 000000	100.0000%	9.79
Ziploc Food Storage and Sandwich Bags Variety Pack, New Stay Open Design with Stand-Up Bottom, Easy to Fill, 166 Bags Total	10 E 2222 4100 00 300 000000	100.0000%	11.99
Asian Asian American and Pacific Islander Heritage Month Banner 3 x 6 ft Outdoor Yard Garden Flag Party Decoration Poster	10 E 2222 4100 00 300 000000	100.0000%	25.23
Trandraft 100 Pcs Flower Cut Outs Spring Bulletin Board Decorations with 200 Glue Point Spring Cutout for Bulletin Board Flower Bulletin Border Colorful Wall Decals for School Classroom (Hello Spring)	10 E 2222 4100 00 300 000000	100.0000%	12.99
MJUNM Clear Tape - Matte Transparent Tape Refills Invisible Tape, 900inches, Tear by Hand, Frosted and Invisible on Paper, Perfect for Correction and Labeling,	10 E 2222 4100 00 300 000000	100.0000%	13.98

## Invoice Listing

COUNTY OF GRUNDY SCHOOL DIST 111

Vendor	PO Number	Invoice Number	Batch	Description	Invoice Date	Check Number	Net Amount
<u>Detail Description</u>				<u>Detail Account</u>	<u>Accounting Percent</u>		<u>Detail Amount</u>
National Arab American Heritage Month Backdrop Party Banner Holiday Decoration Photo Booth Background Tapestry 70 * 35 Inches Decor Supplies Sign For Home Office				10 E 2222 4100 00 300 000000	100.0000%		10.99
Cost of shipping, not including shipping tax.				10 E 2222 4100 00 300 000000	100.0000%		6.00
Amazon Capital Services, Inc.	1012400015	1PNC-JGCP-W4N7	DFC	Central Campus Library Supplies	04/09/2024	9100002312	140.48
<u>Detail Description</u>				<u>Detail Account</u>	<u>Accounting Percent</u>		<u>Detail Amount</u>
Elmer's All Purpose School Glue Sticks, Washable, 7 Grams, 30 Count				10 E 2222 4100 00 300 000000	100.0000%		7.37
KWF-12 Charcoal Water Filters for Keurig Coffee Machines, 12 Count (Pack of 1), White				10 E 2222 4100 00 300 000000	100.0000%		7.99
SKKSTATIONERY Pre-sharpened pencils, Pencils Sharpened with eraser top, 2 HB pencil, 144/box.				10 E 2222 4100 00 300 000000	100.0000%		16.39
Prompta 400 Conversation Cards for Friends – Casual, Funny Get to Know You Conversation Starters to Connect with Friends				10 E 2222 4100 00 300 000000	100.0000%		24.99
20 Pieces Japanese Chinese Lanterns Decoration Includes 6 Cherry Flowers Japanese Paper Lanterns 14 Chinese Red Lanterns 12 Inch Cherry Blossom Lanterns Home Decor for New Year (White)				10 E 2222 4100 00 300 000000	100.0000%		18.99 61
52 Pcs Ramadan Mubarak Decorations Arabian Nights Party Decoration Eid Mubarak Hanging Swirls Ceiling Foil Party Decoration for Indian Moroccan Princess Birthday Supplies				10 E 2222 4100 00 300 000000	100.0000%		9.79
3 Pieces Purple and Gold Tablecloth Nights Tablecover Purple Plastic Tablecloth Purple and Gold Birthday Party Nights Decorations Supplies				10 E 2222 4100 00 300 000000	100.0000%		11.99
Asian Asian American and Pacific Islander Heritage Month Banner 3 x 6 ft Outdoor Yard Garden Flag Party Decoration Poster				10 E 2222 4100 00 300 000000	100.0000%		12.99
Trandraft 100 Pcs Flower Cut Outs Spring Bulletin Board Decorations with 200 Glue Point Spring Cutout for Bulletin Board Flower Bulletin Border Colorful Wall Decals for School Classroom (Hello Spring)				10 E 2222 4100 00 300 000000	100.0000%		12.99
National Arab American Heritage Month Backdrop Party Banner Holiday Decoration Photo Booth Background Tapestry 70 * 35 Inches Decor Supplies Sign For Home Office				10 E 2222 4100 00 300 000000	100.0000%		10.99
Cost of shipping, not including shipping tax.				10 E 2222 4100 00 300 000000	100.0000%		6.00

## Invoice Listing

COUNTY OF GRUNDY SCHOOL DIST 111

Vendor	PO Number	Invoice Number	Batch	Description	Invoice Date	Check Number	Net Amount
Amazon Capital Services, Inc.	1022400106	1PNC-JGCP-W4N7	DFC	Tripod Weights for Graduation Camera and Outdoor Ethernet for AP install at Football Stadium for Track.	04/09/2024	9100002312	298.60
<b>Detail Description</b>				<b>Detail Account</b>	<b>Accounting Percent</b>		<b>Detail Amount</b>
Logitech Wireless Presenter R400, Wireless Presentation Remote Clicker with Laser Pointer				10 E 2225 4100 00 300 000000	100.0000%		86.97
VIVO Black 500ft Bulk Cat6, CCA Ethernet Cable, 23 AWG, UTP Pull Box, Cat-6 Wire, Waterproof, Outdoor, Direct Burial CABLE-V012				10 E 2225 4100 00 300 000000	100.0000%		66.49
Highwings 4K60HZ 50 FT HDMI Cable Fiber Optic Long, Unidirectional 2.0 High-Speed HDMI Braided Cord Support HDR Video 4K 2160p 1080p 3D HDCP 2.2 ARC-Compatible with Ethernet Monitor PS4/3 Fire				10 E 2225 4100 00 300 000000	100.0000%		91.17
Tripod Sand Bag for Tripod/Easel,Tripod Stone Bag with 9 Extra Pockets,Tripod Weight Bag for Photography Painter,Heavy Duty Sandbag Tripod Hammock, Adjustable Buckles on The Tripod Legs				10 E 2225 4100 00 300 000000	100.0000%		53.97
Amazon Capital Services, Inc.	1022400108	1PNC-JGCP-W4N7	DFC	Fiber equipment for ADCTR to Central Campus	04/09/2024	9100002312	183.90 62
<b>Detail Description</b>				<b>Detail Account</b>	<b>Accounting Percent</b>		<b>Detail Amount</b>
10GBase-SR SFP+ Transceiver, 850nm MMF, up to 300 Meters, Compatible with Cisco SFP-10G-SR, Meraki MA-SFP-10GB-SR, Ubiquiti UniFi UF-MM-10G, Fortinet, Mikrotik, Netgear, TP-Link and More				10 E 2225 4100 00 300 000000	100.0000%		107.94
10Gtek 10GBase-LR SFP+ Transceiver, 10G 1310nm SMF SingleMode LC Fiber Optic Module, up to 10km, for Cisco SFP-10G-LR, Meraki MA-SFP-10GB-LR, Ubiquiti UniFi UF-SM-10G, Mikrotik, Fortinet, TP-Link				10 E 2225 4100 00 300 000000	100.0000%		75.96
Amazon Capital Services, Inc.	1042400031	1NRD-KFGN-XK91	DFC	Keypads Jim Kelly approved	03/12/2024	9100002312	64.52
<b>Detail Description</b>				<b>Detail Account</b>	<b>Accounting Percent</b>		<b>Detail Amount</b>
MOFii Wireless Keyboard and Mouse Combo, USB 2.4GHz Full Size Typewriter Keyboard with Number Pad and Sport Car Mouse for Office PC Computer Desktop Laptop Windows (Black Colorful)				10 E 1500 4100 70 300 000007	100.0000%		19.55
MOFII Wireless Number Pad - 2.4G Numeric Keypad Silent 19 Keys USB Keypads, Portable Financial Accounting Numpad 10 Key for Laptop/Notebook/Surface Pro/PC - Black				10 E 1500 4100 70 300 000007	100.0000%		44.97

## Invoice Listing

COUNTY OF GRUNDY SCHOOL DIST 111

Vendor	PO Number	Invoice Number	Batch	Description	Invoice Date	Check Number	Net Amount
Amazon Capital Services, Inc.	1042400033	1HVY-CC14-6DKK	DFC	First Aid Kit	03/26/2024	9100002312	41.01
<b>Detail Description</b>		<b>Detail Account</b>		<b>Accounting Percent</b>	<b>Detail Amount</b>		
276PCS First Aid Kit Home Car Camping Hiking Emergency Supplies Small Compact Lovely Bag for School Outdoor, Basic Outdoor Essentials Survival Kit for Travel AMORNING		10 E 1500 4100 70 300 000006		100.0000%	41.01		
Amazon Capital Services, Inc.	1052400038	1NRD-KFGN-XK91	DFC	Sped file room supplies	03/12/2024	9100002312	64.87
<b>Detail Description</b>		<b>Detail Account</b>		<b>Accounting Percent</b>	<b>Detail Amount</b>		
Avery TrueBlock Extra Large File Folder Labels, 15/16" x 3-7/16", 450 Printable Labels, White (5027)		10 E 1200 4100 00 300 000000		100.0000%	20.82		
Staples 117713 Interior File Folders Letter Size Manila 100/Box (117713)		10 E 1200 4100 00 300 000000		100.0000%	11.81		
100 Blue Summit Supplies Gray File Folders, Letter Size, 1/3 Cut Tab, Great Folder for Organizing and Easy File Storage, 100 Pack		10 E 1200 4100 00 300 000000		100.0000%	20.26		
Printable Sticker Paper for Inkjet Printer, 40 Sheets 8.5"x11" Matte Sticker Printer Paper Full Sheet Labels, Sticker Paper for Printer Sticker Labels, for Laser/Inkjet Printers, Letter Size		10 E 1200 4100 00 300 000000		100.0000%	11.98 63		
Amazon Capital Services, Inc.	1062400019	1HVY-CC14-6DKK	DFC	Duct lifter for removing/installing the Orchestra Pit cover	03/26/2024	9100002312	899.99
<b>Detail Description</b>		<b>Detail Account</b>		<b>Accounting Percent</b>	<b>Detail Amount</b>		
VEVOR Manual Winch Stacker, 41.7"L x 25.8"W Hand Winch Lift Trucks w/ 8.7" – 106.3" Height Range, with 441 lbs Capacity and Adjustable Straddle, Material Lifts for Warehouse and Factory		20 E 2540 4100 00 300 000000		100.0000%	899.99		
Amazon Capital Services, Inc.	1062400022	1PNC-JGCP-W4N7	DFC	Coaches/officials locker room bench	04/09/2024	9100002312	980.00
<b>Detail Description</b>		<b>Detail Account</b>		<b>Accounting Percent</b>	<b>Detail Amount</b>		
COATEDOUTDOORFURNITURE B6P-ORG Heavy Duty Park Bench Without Back Portable Frame, 6 Ft, Orange, Made in America		20 E 2540 4100 00 300 000000		100.0000%	980.00		

## Invoice Listing

COUNTY OF GRUNDY SCHOOL DIST 111

Vendor	PO Number	Invoice Number	Batch	Description	Invoice Date	Check Number	Net Amount
Amazon Capital Services, Inc.	1082400018	1P7K-FJ13-16JD	DFC	MadeGood Chocolate Chip Granola Bars (40 Count, 0.85oz Each) Non-GMO, Nut Free, Organic, Nutrients from Vegetables, Vegan, Gluten Free	03/19/2024	9100002312	105.56
<b>Detail Description</b>				<b>Detail Account</b>	<b>Accounting Percent</b>		<b>Detail Amount</b>
MadeGood Chocolate Chip Granola Bars (40 Count, 0.85oz Each) Non-GMO, Nut Free, Organic, Nutrients from Vegetables, Vegan, Gluten Free				10 E 2230 4100 00 300 000000	100.0000%		105.56
Amazon Capital Services, Inc.	1082400020	1HVY-CC14-6DKK	DFC	TALK Day Supplies	03/26/2024	9100002312	140.91
<b>Detail Description</b>				<b>Detail Account</b>	<b>Accounting Percent</b>		<b>Detail Amount</b>
Dixie Ultra, Large Paper Plates, 10 Inch, 100 Count, 3X Stronger*, Heavy Duty, Microwave-Safe, Soak-Proof, Cut Resistant, Great For Heavy, Messy Meals				10 E 2210 4000 00 300 000001	100.0000%		44.97
Avery Customizable Name Tags, 2-1/3" x 3-3/8", White with Blue Border, 100 Removable Name Badges (05144)				10 E 2210 4000 00 300 000001	100.0000%		13.56
Moretoes 48 Pack Treat Boxes, 6 x 3.5 x 3.5 Inch Party Favor Boxes, Multi-color Candy Gable Boxes for Kids, Snacks, Candy, Toys, Birthday Party, Wedding, Halloween, Christmas				10 E 2210 4000 00 300 000001	100.0000%		63.96
EDI PS Party Cups Red - 16 oz (100 pcs) (100, 16 Oz)				10 E 2210 4000 00 300 000001	100.0000%		64
							18.42

## Invoice Listing

COUNTY OF GRUNDY SCHOOL DIST 111

Vendor	PO Number	Invoice Number	Batch	Description	Invoice Date	Check Number	Net Amount
Amazon Capital Services, Inc.	1092400086	1NRD-KFGN-XK91	DFC	Industrial tech materials	03/12/2024	9100002312	643.88

Detail Description	Detail Account	Accounting Percent	Detail Amount
Kreg SPS-C1-100 Zinc Pocket-Hole Screws, 1-Inch #7 Coarse Thread, Pan Head (100 Count)	10 E 1400 4100 10 300 000001	100.0000%	12.96
Amazon Basics 3-Button Wired USB Computer Mouse, Single, Black	10 E 1400 4100 10 300 000001	100.0000%	60.50
Kreg SML-C125-250 Zinc Pocket Screws, 1 1/4 Inch #8 Coarse Thread, Maxi-Loc Head, (250 Count)	10 E 1400 4100 10 300 000001	100.0000%	112.00
1 Hole Punch, 5 Sheet Capacity, Comes in 2 Pack, Silver (90073)	10 E 1400 4100 10 300 000001	100.0000%	11.64
100 Pcs Plastic Roll 2mm Dia Shaft Toys Car Wheel for DIY Model Toy RC Car Truck Building Projects	10 E 1400 4100 10 300 000001	100.0000%	27.98
Wire Brush, Heavy Duty Stainless Steel Wire Scratch Brush for Cleaning Rust with 10" Curved Beechwood Handle, 2 Pieces	10 E 1400 4100 10 300 000001	100.0000%	24.32
Gebildet 6pcs DC3V-12V DC Prewired Geared Motor for Four-Wheel Drive Toy Car/Robotic Body/Aircraft Toys. Batch Number: Double Axis 1:48	10 E 1400 4100 10 300 000001	100.0000%	118.68
Stainless Steel C Clamps Small 1 1/2 Inch for Mounting, Heavy Duty U Clamps for Metal Working, Mini Desk Clamp with Stable Wide Jaw Opening & Protective Pads/I-Beam Design (2pcs)	10 E 1400 4100 10 300 000001	100.0000%	65 35.98
Basswood Sheets for Crafts 1/8 inch, 3mm Plywood Sheets for Laser Cutting, Wood Burning, Architectural Models, Drawing - 10 Pack Bass Wood 12 x 12 inch (SS Custom Products)	10 E 1400 4100 10 300 000001	100.0000%	185.10
VASTOOLS Single Flint Torch Striker, Single Flint Lighter Pack of 2, for Welding and Cutting, 20pcs Flint Replacements	10 E 1400 4100 10 300 000001	100.0000%	12.99
80pcs 2mm Shaft Sleeves Plastic Axle Sleeves DIY Toy Accessories (Orange, Soft)	10 E 1400 4100 10 300 000001	100.0000%	14.98
ThtRht 30 Pack Self-Lock Micro Push Button Switch Flat 2 PIN with Hole Mini ON/Off Push Button JIA Teng KAN-28 1.5A 250V for Flashlight SMD 18 X 12mm 1812-28A DIY Hiden Switches Model Car Block Toys	10 E 1400 4100 10 300 000001	100.0000%	13.76
EUDAX 100Pcs Dia.2mm STEM Toys Shaft Round Rod Axles for DIY Toy RC Car Boat Helicopter Model Part (2mmx150mm)	10 E 1400 4100 10 300 000001	100.0000%	12.99

## Invoice Listing

COUNTY OF GRUNDY SCHOOL DIST 111

Vendor	PO Number	Invoice Number	Batch	Description	Invoice Date	Check Number	Net Amount
Amazon Capital Services, Inc.	1092400087	1NRD-KFGN-XK91	DFC	Replacement cookware for central campus. The existing pans are peeling and no longer safe to use.	03/12/2024	9100002312	2,837.56
				<b>Detail Description</b>	<b>Detail Account</b>	<b>Accounting Percent</b>	<b>Detail Amount</b>
				All-Clad HA1 Hard Anodized Nonstick Cookware Set 10 Piece Induction Oven Broiler Safe 500F, Lid Safe 350F Pots and Pans Black	10 E 1420 5400 09 300 000000	100.0000%	735.78
				All-Clad HA1 Hard Anodized Nonstick Cookware Set 13 Piece Induction Oven Broiler Safe 500F, Lid Safe 350F Pots and Pans Black	10 E 1420 5400 09 300 000000	100.0000%	925.80
				All-Clad HA1 7-Piece Hard Anodized Nonstick Dishwasher Safe PFOA Free Cookware Set, Black	10 E 1420 5400 09 300 000000	100.0000%	876.00
				All-Clad HA1 Hard Anodized Nonstick Fry Pan Set 5 Piece, 8, 10, 12 Inch Induction Oven Broiler Safe 500F, Lid Safe 350F Pots and Pans, Cookware Black	10 E 1420 5400 09 300 000000	100.0000%	299.98
Amazon Capital Services, Inc.	1092400088	1HVY-CC14-6DKK	DFC	Foods equipment replacement. We had three food processors die and burn out, I need them for my advanced culinary class. We are hosting a breakfast for the Reach students and need chaffing dishes, these will be used for other events we host as well. Pyrex measuring cups have broken and need to be replaced.	03/26/2024	9100002312	289.19
							66
				<b>Detail Description</b>	<b>Detail Account</b>	<b>Accounting Percent</b>	<b>Detail Amount</b>
				OXO Good Grips 3-Piece Angled Measuring Cup Set, Black	10 E 1420 5400 09 300 000000	100.0000%	93.28
				TreeLen Broom and Dustpan Set with 52" Long Handle for Home Kitchen Room Office Lobby Floor Use Upright Stand Up Stand Up Broom with Dustpan Combo	10 E 1420 5400 09 300 000000	100.0000%	95.96
				Pastry Cutter, Biscuit Cutter, Dough Scraper, Silicone Baking Mats, Stainless Steel Pastry Blender Set, Dough Cutter Biscuit Cutter Baking Pastry Mat Dough Blender Tools & Pastry Utensils (5 Pcs/Set)	10 E 1420 5400 09 300 000000	100.0000%	99.95

## Invoice Listing

COUNTY OF GRUNDY SCHOOL DIST 111

Vendor	PO Number	Invoice Number	Batch	Description	Invoice Date	Check Number	Net Amount
Amazon Capital Services, Inc.	1092400090	1HVY-CC14-6DKK	DFC	Kitchen supplies for south, replacing worn out cookware old knives, towels that are old, stained aprons, etc, its been 5 years since its been updated/ replaced.	03/26/2024	9100002312	1,340.09

Detail Description	Detail Account	Accounting Percent	Detail Amount
IMUSA USA 14" Traditional Nonstick Coated Wok with Triangle Helper Handle	10 E 1420 4100 09 300 000000	100.0000%	79.95
Rachael Ray - 87630 Rachael Ray Cucina Hard Anodized Nonstick Cookware Pots and Pans Set, 12 Piece, Gray with Red Handles	10 E 1420 4100 09 300 000000	100.0000%	801.85
Syntus 12 Pack Bib Apron, Unisex Aprons Adjustable Waterdrop Resistant with 2 Pockets Cooking Kitchen Apron for Chef, BBQ Drawing Apron Bulk, Nautical Blue	10 E 1420 4100 09 300 000000	100.0000%	95.94
Infinitee Xclusives Premium Dish Cloth - Grey [Pack of 4] 100% Cotton 13 x 13 Inches Kitchen Cloth - Absorbent Kitchen Rags - Terry Dishcloth for Kitchen Household Cleaning	10 E 1420 4100 09 300 000000	100.0000%	62.40
6Pcs Kitchen Knife Set with In-Drawer Bamboo Knife Organizer- 3.5-8 Inch Set Kitchen Knives German High Carbon Stainless Steel Sharp Knife, Knives Set for Kitchen with Ergonomic Handle Gift Box	10 E 1420 4100 09 300 000000	100.0000%	299.95
			67

Amazon Capital Services, Inc.	1092400091	1HVY-CC14-6DKK	DFC	Replacement items - These were on a previous order and Amazon was out of stock and cancelled the order. It is replacement food processors, and chaffing dishes for the REACH breakfast.	03/26/2024	9100002312	633.42
-------------------------------	------------	----------------	-----	---	------------	------------	--------

Detail Description	Detail Account	Accounting Percent	Detail Amount
SUPER DEAL Newest 4 Pack 8QT Food Warmer, Rectangular Chafing Dish Buffet Set w/Foldable Frame Legs, Stainless Steel Full Size Chafer Dish for Parties	10 E 1420 5400 09 300 000000	100.0000%	73.49
Cost of shipping, not including shipping tax.	10 E 1420 5400 09 300 000000	100.0000%	49.99
Ninja NF701 Professional XL Food Processor, 1200 Peak-Watts, 4-in-1, Chopping, Slicing/Shredding, Purees, Dough, 12-Cup Processor Bowl, 2 Blades & 2 Discs, Feed Chute/Pusher, Silver	10 E 1420 5400 09 300 000000	100.0000%	509.94

## Invoice Listing

COUNTY OF GRUNDY SCHOOL DIST 111

Vendor	PO Number	Invoice Number	Batch	Description	Invoice Date	Check Number	Net Amount
Amazon Capital Services, Inc.	1092400092	1PNC-JGCP-W4N7	DFC	supplies for welding and electrical	04/09/2024	9100002312	408.04

Detail Description	Detail Account	Accounting Percent	Detail Amount
DEWALT DW4514 1/4" Thick Grinding Wheel with 4-1/2" Diameter and 7/8" Arbor	10 E 1400 4100 10 300 000001	100.0000%	7.32
DEWALT Angle Grinder, One-Touch Guard, 4-1/2 -Inch (DWE4011)	10 E 1401 4100 01 300 000000	100.0000%	79.00
Dremel 3000-1/25 Variable Speed Rotary Tool Kit- 1 Attachment and 25 Accessories- Grinder, Mini Sander, Polisher, Router, Engraver- Perfect for Routing, Metal Cutting, Wood Carving, Polishing	10 E 1400 4100 10 300 000001	100.0000%	113.56
WGGE WG-026 10 Pieces and 5 Colors Test Lead Set & Alligator Clips,20.5 inches / 22 AWG Wire (5 Pack)	10 E 1400 4100 10 300 000001	100.0000%	15.89
AUSTOR Aluminum Oxide Sanding Drum Set with Free Box Including 120 Pieces Drum Sander Sanding Sleeves and 12 Pieces Drum Mandrels for Dremel Rotary Tool, 132 Pieces	10 E 1400 4100 10 300 000001	100.0000%	8.59
BNTECHGO 22 Gauge Silicone Wire Spool red 25ft and Black 25ft Flexible 22 AWG Stranded Tinned Copper Wire	10 E 1400 4100 10 300 000001	100.0000%	37.92
YESWELDER TIG Welding Tungsten Electrode 2% Thoriated 3/32" x 7" (Red, WT20/EWTh-2) 10-pk	10 E 1400 4100 10 300 000001	100.0000%	68 45.78
Kuenuilr Cutting Wheel Set Compatible with Plastic 36pcs for Rotary Tool, HSS Circular Saw Blades 6pcs, Resin Cutting Discs 20pcs, 545 Diamond Cutting Wheels 10psc with 2 Screwdrivers	10 E 1400 4100 10 300 000001	100.0000%	9.99
Gas One 6 Hour Chafing Fuel - Food Warmer for Chafing Dish Buffet Set - Liquid Safe Fuel With Wick & Lid Opener 7.4 Oz (Pack of 12)	10 E 1400 4100 10 300 000001	100.0000%	25.99
AYAO 70 1/2 inch Bandsaw Blades, 5pk, Ground Tooth (70 1/2" X 1/4" X 6TPI, 5pk)	10 E 1400 4100 10 300 000001	100.0000%	64.00

Amazon Capital Services, Inc.	1102400011	1KFK-NGVX-7T1X	DFC	Women's History Month Door Decor for March. In alignment with the School Improvement Team initiative to celebrate diversity throughout departments.	04/02/2024	9100002312	16.99
-------------------------------	------------	----------------	-----	---	------------	------------	-------

Detail Description	Detail Account	Accounting Percent	Detail Amount
Women's History Month Decorations Door Banner with Hanging Sign, 71" X 12" Women's History Month Banner Door Decorations Yard Porch Sign, National Womens History Month Decor Porch Banner Indoor Outdoor	10 E 1130 4100 05 300 000000	100.0000%	16.99

## Invoice Listing

COUNTY OF GRUNDY SCHOOL DIST 111

Vendor	PO Number	Invoice Number	Batch	Description	Invoice Date	Check Number	Net Amount
Amazon Capital Services, Inc.	1102400011	1NRD-KFGN-XK91	DFC	Women's History Month Door Decor for March. In alignment with the School Improvement Team initiative to celebrate diversity throughout departments.	03/12/2024	9100002312	16.99
<b>Detail Description</b>				<b>Detail Account</b>	<b>Accounting Percent</b>		<b>Detail Amount</b>
Women's History Month Decorations Door Banner with Hanging Sign, 71" X 12" Women's History Month Banner Door Decorations Yard Porch Sign, National Womens History Month Decor Porch Banner Indoor Outdoor				10 E 1130 4100 05 300 000000	100.0000%		16.99
Amazon Capital Services, Inc.	1112400028	1HVY-CC14-6DKK	DFC	Label maker, markers, frames for math artwork in classrooms (pi day pictures), and measuring tapes for classroom activities.	03/26/2024	9100002312	114.34
<b>Detail Description</b>				<b>Detail Account</b>	<b>Accounting Percent</b>		<b>Detail Amount</b>
EXPO Low Odor Dry Erase Markers, Fine Tip, Assorted Colors, 12 Count				10 E 1130 4100 11 300 000000	100.0000%		38.15
LOUHUA Tape Measures 24 Pack Measuring Tape Bulk for Body Sewing Tailor Cloth Craft Supplies Knitting Projects Measurement Double Scale 150cm/60inch				10 E 1130 4100 11 300 000000	100.0000%		7.99
Giftgarden Black 8x10 Picture Frame Bulk, Multi 8 x 10 Photo Frames Set for Wall Hanging or Tabletop, 12 Pack				10 E 1130 4100 11 300 000000	100.0000%		69 28.21
Brother P-Touch Label Maker, PTD220, Thermal, Inkless Printer for Home & Office Organization, Portable & Lightweight, QWERTY Keyboard, One-Touch Keys & 25 Pre-Set Label Templates Label Memory				10 E 1130 4100 11 300 000000	100.0000%		39.99
Amazon Capital Services, Inc.	1112400029	1HVY-CC14-6DKK	DFC	Professional Development	03/26/2024	9100002312	39.21
<b>Detail Description</b>				<b>Detail Account</b>	<b>Accounting Percent</b>		<b>Detail Amount</b>
Modifying Your Thinking Classroom for Different Settings: A Supplement to Building Thinking Classrooms in Mathematics (Corwin Mathematics Series)				10 E 2210 3000 11 300 000000	100.0000%		39.21
Amazon Capital Services, Inc.	1122400037	1P7K-FJ13-16JD	DFC	Individual Sports Equipment for Unit/Curriculum	03/19/2024	9100002312	262.36
<b>Detail Description</b>				<b>Detail Account</b>	<b>Accounting Percent</b>		<b>Detail Amount</b>
GoSports 90 mm Backyard Bocce Set with 8 Balls, Pallino, Case and Measuring Rope - Made from Premium Resin				10 E 1130 4100 50 300 000000	100.0000%		262.36

## Invoice Listing

COUNTY OF GRUNDY SCHOOL DIST 111

Vendor	PO Number	Invoice Number	Batch	Description	Invoice Date	Check Number	Net Amount
Amazon Capital Services, Inc.	1132400026	1HVY-CC14-6DKK	DFC	General Classroom Supplies for the Science Department.	03/26/2024	9100002312	296.27

Detail Description	Detail Account	Accounting Percent	Detail Amount
EXPO Low Odor Dry Erase Markers, Chisel Tip, Black, 36 Count	10 E 1130 4100 13 300 000000	100.0000%	163.52
EXPO Low Odor Dry Erase Marker, Chisel Tip Markers, Whiteboard Markers, Assorted, 36 Count	10 E 1130 4100 13 300 000000	100.0000%	86.76
Amazon Basics White Board Eraser, Dry Erase Whiteboard Erasers for Office, Home and Classroom, Black, 4-Pack	10 E 1130 4100 13 300 000000	100.0000%	21.00
KTRIO 500 Pack Sheet Protectors 8.5 x 11 inch, Clear Page Protectors for 3 Ring Binder, Plastic Sleeves for Binders, Top Loading Paper Protector Letter Size	10 E 1130 4100 13 300 000000	100.0000%	24.99

Amazon Capital Services, Inc.	1152400079	1NRD-KFGN-XK91	DFC	Foreign Language Week Supplies	03/12/2024	9100002312	36.95
-------------------------------	------------	----------------	-----	--------------------------------	------------	------------	-------

Detail Description	Detail Account	Accounting Percent	Detail Amount
Assorted Candy Variety Pack - Individually Wrapped Party Candy Assortment - Candy For Every Occasion! (64 Ounces)	10 E 1130 4100 06 300 000000	100.0000%	36.95

70

## Invoice Listing

COUNTY OF GRUNDY SCHOOL DIST 111

Vendor	PO Number	Invoice Number	Batch	Description	Invoice Date	Check Number	Net Amount
Amazon Capital Services, Inc.	1152400084	1NRD-KFGN-XK91	DFC	Photo supplies	03/12/2024	9100002312	282.51

Detail Description	Detail Account	Accounting Percent	Detail Amount
P50 Model Trains Architectural 1:50 O Scale Painted Figures O Gauge Sitting and Standing People for Miniature Scenes New (100PCS)	10 E 1130 4100 02 300 000000	100.0000%	13.99
60pcs O Gauge Painted Figures P4310-60-NUS Model Trains Passengers 30 Different Poses People Model Railway for Miniature Scenes	10 E 1130 4100 02 300 000000	100.0000%	29.99
Zhanmai 24 Pieces Glow Fiber Wands Sticks LED Light Wands Fiber Optic Wands LED Flashing Sticks Glow Flashing Wands Fiber Optic Wands for Party Favors (Multicolor)	10 E 1130 4100 02 300 000000	100.0000%	18.99
GISELA D Acrylic Mirror Reflection Board Geometric Shape Photo Background Props Set Photography Ornaments Reflective Display Sheet (8Pcs)	10 E 1130 4100 02 300 000000	100.0000%	43.00
Kcgani Clear Polished Acrylic Cube Cylinder Round Photo Props, Transparent Solid Acrylic Display Blocks for Photography Boutique Jewelry Cosmetic Crafts Closet Show, 4 Pcs (Transparent Cylinder)	10 E 1130 4100 02 300 000000	100.0000%	47.98
3PCS Simulation Window Light Shadow Photography Background Board, Waterproof Reusable Photo Tabletop Backdrops for Food Cosmetics Jewelry Ornaments Makeup Skin Care Small Product	10 E 1130 4100 02 300 000000	100.0000%	95.98
Kasyat 10 Pieces Fiber Optic Light Wand Stick Glow Flashing Wands Fiber Optic Wands LED Flashing Sticks LED Fiber Wands Colorful Flashing LED Wands for Boys and Girls Party Favors (Vivid Color)	10 E 1130 4100 02 300 000000	100.0000%	25.58
Cost of shipping, not including shipping tax.	10 E 1130 4100 02 300 000000	100.0000%	7.00

## Invoice Listing

COUNTY OF GRUNDY SCHOOL DIST 111

Vendor	PO Number	Invoice Number	Batch	Description	Invoice Date	Check Number	Net Amount
Amazon Capital Services, Inc.	1152400088	1HVY-CC14-6DKK	DFC	Art supplies for sculpture	03/26/2024	9100002312	83.29

Detail Description	Detail Account	Accounting Percent	Detail Amount
J-B Weld 8277 WaterWeld Epoxy Putty Stick - 2 oz., Off White	10 E 1130 4100 02 300 000000	100.0000%	6.54
Kintsukuroi Glue, 25ml Kintsugi Instant Mix Epoxy Adhesives, High Viscosity Kintsugi for Kintsugi Art, Supplement for Special-purpose Glue in Kintsugi Repair Kit, High-strength Bonding, Repair Lasting	10 E 1130 4100 02 300 000000	100.0000%	10.99
YFDB Underglaze Pencils, (Black, 2ps) Underglaze Pencils for Pottery. Black Underglaze Pencil Precision Underglaze Pencil for Pottery	10 E 1130 4100 02 300 000000	100.0000%	53.97
VIKEYTIM Epoxy Putty, 120g Quick Leak Repair Epoxy Putty Plastic, Ceramic, Acrylic, Metal, Stone, Wood, Glass Bonding and Repair Putty Stick (White)	10 E 1130 4100 02 300 000000	100.0000%	11.79

72

## Invoice Listing

COUNTY OF GRUNDY SCHOOL DIST 111

Vendor	PO Number	Invoice Number	Batch	Description	Invoice Date	Check Number	Net Amount
Amazon Capital Services, Inc.	1152400090	1HVY-CC14-6DKK	DFC	Paint for Art class	03/26/2024	9100002312	487.65

Detail Description	Detail Account	Accounting Percent	Detail Amount
Apple Barrel Acrylic Paint in Assorted Colors (8 oz), 20429 Christmas Green	10 E 1130 4100 02 300 000000	100.0000%	5.34
Apple Barrel Acrylic Paint in Assorted Colors (8 Ounce), 20404 Black	10 E 1130 4100 02 300 000000	100.0000%	5.94
Apple Barrel Acrylic Paint in Assorted Colors (8 Ounce), 20403 White	10 E 1130 4100 02 300 000000	100.0000%	5.34
Apple Barrel Acrylic Paint in Assorted Colors (8 Ounce), J20432 Nutmeg	10 E 1130 4100 02 300 000000	100.0000%	5.94
Apple Barrel Acrylic Paint in Assorted Colors (8 oz), K2602 Bright Magenta	10 E 1130 4100 02 300 000000	100.0000%	5.94
Apple Barrel Acrylic Paint in Assorted Colors (8 oz), K2616 True Navy	10 E 1130 4100 02 300 000000	100.0000%	5.34
IRIS USA 10 Pack Medium Plastic Hobby Art Craft Supply Organizer Storage Containers with Latching Lid, for Pens & Pencils, Ribbons, Wahi Tape, Beads, Sticker, Yarn, Ornaments, Stackable, Clear	10 E 1130 4100 02 300 000000	100.0000%	19.99
Apple Barrel Acrylic Paint (8 Ounce), Bright Blue, 8 oz, 8 Fl Oz	10 E 1130 4100 02 300 000000	100.0000%	5.94
Apple Barrel 20745 Acrylic Paint (8-Ounce), 2075 Burnt Umber, 8 oz	10 E 1130 4100 02 300 000000	100.0000%	22.98
TECH-P Creative Life 2" Hexagon Shape Hand Press Album Cards Paper Craft Punch, Card Scrapbooking Engraving Kid Cut DIY Paper Craft Punch	10 E 1130 4100 02 300 000000	100.0000%	33.98
Craft Lever Punch 3 inch Ware Circle Punch DIY Handmade Paper Punch (3 inch Ware Circle ramdon Colour)	10 E 1130 4100 02 300 000000	100.0000%	49.98
3 Pieces Handheld Hole Paper Punch Metal Single Hole Paper Punch Punchers with Soft Grip and 0.25 Inch Circle 0.2 Inch Star 0.22 Inch Heart Holes for DIY Craft Tags Clothing Ticket Scrapbook Tool	10 E 1130 4100 02 300 000000	100.0000%	25.58
3 Pieces Handheld Hole Punch Tiny Shaped Circle Punchers Metal Single Hole Paper Punch with Plastic Handle for 10 Sheet Tags Clothing Ticket (Pink Purple Blue, Vivid Style)	10 E 1130 4100 02 300 000000	100.0000%	29.98
Apple Barrel Acrylic Craft Paint Set, Matte Finish, Set of 8, 8 Fl Oz (Pack of 8), Assorted	10 E 1130 4100 02 300 000000	100.0000%	46.72

## Invoice Listing

COUNTY OF GRUNDY SCHOOL DIST 111

Vendor	PO Number	Invoice Number	Batch	Description	Invoice Date	Check Number	Net Amount
				<b>Detail Description</b>			<b>Detail Account</b>
					<b>Accounting Percent</b>	<b>Detail Amount</b>	
				UCEC Paper Punches for Crafting, 1 Inch Paper Puncher, 6 Pcs Hole Punch Shapes Cutters for Paper Craft Heart, Circle, Star, Butterfly, Maple Leaf, Flower Paper Punch Sets for DIY Projects Scrapbook	100.0000%	50.58	
				Citylife 5 PCS Plastic Storage Bins with Latching Lids Portable Project Case Clear File Box Stackable Storage Containers for Organizing A4 Paper, Photo, Document, Scrapbook	100.0000%	93.34	
				Ecohu Set 3 Star Paper Punch 0.3" / 0.63" / 1", Scrapbooking Hole Punches Crafting, Design for Office Supplies, Card Making, DIY Photo Album.	100.0000%	26.90	
				Koogel 3PCS Paper Hole Punches, Craft Paper Punch Set Lever Punch Hole Punch Shapes for Scrapbooking Festival Paper Greeting Card DIY Albums Photos	100.0000%	19.96	
				Craft Punch Set 3 Pcs (5/8", 1", 1 1/2"), Heart Punch Shapes Craft Paper Cutter Hole Puncher for Crafting on Card Stock, Plain Paper, Corrugated Paper, Sponge Paper, Photo Paper, Vinyl Sticker	100.0000%	27.88	
Amazon Capital Services, Inc.	1172400023	1NRD-KFGN-XK91	DFC	Comics for South	03/12/2024	9100002312	<b>74.69</b>
				<b>Detail Description</b>			<b>Detail Account</b>
					<b>Accounting Percent</b>	<b>Detail Amount</b>	
				Disney Twisted-Wonderland, Vol. 3: The Manga: Book of Heartslabyul (3)	100.0000%	11.69	
Amazon Capital Services, Inc.	1172400042	1HVY-CC14-6DKK	DFC	Books for Central Campus	03/26/2024	9100002312	25.20
				<b>Detail Description</b>			<b>Detail Account</b>
					<b>Accounting Percent</b>	<b>Detail Amount</b>	
				James: A Novel	100.0000%	25.20	

## Invoice Listing

COUNTY OF GRUNDY SCHOOL DIST 111

Vendor	PO Number	Invoice Number	Batch	Description	Invoice Date	Check Number	Net Amount
Amazon Capital Services, Inc.	1172400045	1HVY-CC14-6DKK	DFC	Books for Central Campus	03/26/2024	9100002312	325.39

Detail Description	Detail Account	Accounting Percent	Detail Amount
A Thousand Mornings: Poems	10 E 2222 4300 00 300 000000	100.0000%	14.24
Owed (Penguin Poets)	10 E 2222 4300 00 300 000000	100.0000%	16.85
A Poetry Handbook	10 E 2222 4300 00 300 000000	100.0000%	15.29
Primer for Poets	10 E 2222 4300 00 300 000000	100.0000%	12.39
Chasers of the Light: Poems from the Typewriter Series	10 E 2222 4300 00 300 000000	100.0000%	12.50
No Place Like Home: Poems (Everyman's Library Pocket Poets Series)	10 E 2222 4300 00 300 000000	100.0000%	12.99
The Poetry Book (DK Big Ideas)	10 E 2222 4300 00 300 000000	100.0000%	23.80
More Than Meat and Raiment: Poems	10 E 2222 4300 00 300 000000	100.0000%	20.00
suddenly we (Wesleyan Poetry Series)	10 E 2222 4300 00 300 000000	100.0000%	15.18
Poems of Healing (Everyman's Library Pocket Poets Series)	10 E 2222 4300 00 300 000000	100.0000%	13.52
Weaving Sundown in a Scarlet Light: Fifty Poems for Fifty Years	10 E 2222 4300 00 300 000000	100.0000%	13.01
the witch doesn't burn in this one	10 E 2222 4300 00 300 000000	100.0000%	9.29
Inward (The Inward Trilogy)	10 E 2222 4300 00 300 000000	100.0000%	10.80
100 Poems That Matter	10 E 2222 4300 00 300 000000	100.0000%	15.99
The Path to Kindness: Poems of Connection and Joy	10 E 2222 4300 00 300 000000	100.0000%	9.88
Glory in the Margins: Sunday Poems	10 E 2222 4300 00 300 000000	100.0000%	22.00
5-Minute Poetry Writing Prompts: 301 Ideas to Spark Creativity, Build a Writing Habit, and Overcome Writer's Block	10 E 2222 4300 00 300 000000	100.0000%	8.99
Honeybee	10 E 2222 4300 00 300 000000	100.0000%	11.05
Exits	10 E 2222 4300 00 300 000000	100.0000%	13.87
Violet Bent Backwards Over the Grass	10 E 2222 4300 00 300 000000	100.0000%	19.78
Goldenrod: Poems	10 E 2222 4300 00 300 000000	100.0000%	12.05
Blue Ink Tears: A Collection of Poems	10 E 2222 4300 00 300 000000	100.0000%	5.97
How to Communicate: Poems	10 E 2222 4300 00 300 000000	100.0000%	15.95

Amazon Capital Services, Inc.	1172400045	1PNC-JGCP-W4N7	DFC	Books for Central Campus	04/09/2024	9100002312	16.18
-------------------------------	------------	----------------	-----	--------------------------	------------	------------	-------

Detail Description	Detail Account	Accounting Percent	Detail Amount
Poetry Unbound: 50 Poems to Open Your World	10 E 2222 4300 00 300 000000	100.0000%	16.18

## Invoice Listing

COUNTY OF GRUNDY SCHOOL DIST 111

Vendor	PO Number	Invoice Number	Batch	Description	Invoice Date	Check Number	Net Amount
Amazon Capital Services, Inc.	1172400048	1HVY-CC14-6DKK	DFC	Books for South Campus	03/26/2024	9100002312	383.06

Detail Description	Detail Account	Accounting Percent	Detail Amount
Cast Away: Poems of Our Time	10 E 2222 4300 00 300 000000	100.0000%	9.99
Dog Songs: Poems	10 E 2222 4300 00 300 000000	100.0000%	10.94
A Poetry Handbook	10 E 2222 4300 00 300 000000	100.0000%	15.29
Fierce Fairytales: Poems and Stories to Stir Your Soul	10 E 2222 4300 00 300 000000	100.0000%	10.38
Chasers of the Light: Poems from the Typewriter Series	10 E 2222 4300 00 300 000000	100.0000%	12.50
The Poetry Book (DK Big Ideas)	10 E 2222 4300 00 300 000000	100.0000%	23.80
Poems of Healing (Everyman's Library Pocket Poets Series)	10 E 2222 4300 00 300 000000	100.0000%	13.52
Promises of Gold	10 E 2222 4300 00 300 000000	100.0000%	17.99
Say Her Name (Poems to Empower)	10 E 2222 4300 00 300 000000	100.0000%	18.40
Naruto, Vol. 17: Itachi's Power	10 E 2222 4300 00 300 000000	100.0000%	9.79
Naruto, Vol. 18: Tsunade's Choice	10 E 2222 4300 00 300 000000	100.0000%	9.79
Naruto, Vol. 19: Successor	10 E 2222 4300 00 300 000000	100.0000%	9.89
Bleach, Vol. 29	10 E 2222 4300 00 300 000000	100.0000%	8.91
Bleach, Vol. 30	10 E 2222 4300 00 300 000000	100.0000%	9.99
Bleach, Vol. 31	10 E 2222 4300 00 300 000000	100.0000%	9.99
Pluto: Urasawa x Tezuka, Vol. 8 (8)	10 E 2222 4300 00 300 000000	100.0000%	11.96
Inward (The Inward Trilogy)	10 E 2222 4300 00 300 000000	100.0000%	10.80
These Are the Words	10 E 2222 4300 00 300 000000	100.0000%	11.48
The Path to Kindness: Poems of Connection and Joy	10 E 2222 4300 00 300 000000	100.0000%	9.88
5-Minute Poetry Writing Prompts: 301 Ideas to Spark Creativity, Build a Writing Habit, and Overcome Writer's Block	10 E 2222 4300 00 300 000000	100.0000%	8.99
Exits	10 E 2222 4300 00 300 000000	100.0000%	13.87
Boruto: Naruto Next Generations, Vol. 8 (8)	10 E 2222 4300 00 300 000000	100.0000%	7.24
My Hero Academia, Vol. 24 (24)	10 E 2222 4300 00 300 000000	100.0000%	7.39
Boruto: Naruto Next Generations, Vol. 9 (9)	10 E 2222 4300 00 300 000000	100.0000%	8.00
My Hero Academia, Vol. 25 (25)	10 E 2222 4300 00 300 000000	100.0000%	7.49
Boruto: Naruto Next Generations, Vol. 10 (10)	10 E 2222 4300 00 300 000000	100.0000%	8.50
My Hero Academia, Vol. 26 (26)	10 E 2222 4300 00 300 000000	100.0000%	7.95
Spy x Family, Vol. 11 (11)	10 E 2222 4300 00 300 000000	100.0000%	9.58
Violet Bent Backwards Over the Grass	10 E 2222 4300 00 300 000000	100.0000%	19.78

## Invoice Listing

COUNTY OF GRUNDY SCHOOL DIST 111

Vendor	PO Number	Invoice Number	Batch	Description	Invoice Date	Check Number	Net Amount
<b>Detail Description</b>				<b>Detail Account</b>		<b>Accounting Percent</b>	<b>Detail Amount</b>
				the sun will rise and so will we	10 E 2222 4300 00 300 000000	100.0000%	5.99
				Sonic the Hedgehog: The IDW Collection, Vol. 4	10 E 2222 4300 00 300 000000	100.0000%	42.99
Amazon Capital Services, Inc.	1172400048	1PNC-JGCP-W4N7	DFC	Books for South Campus	04/09/2024	9100002312	16.18
<b>Detail Description</b>				<b>Detail Account</b>		<b>Accounting Percent</b>	<b>Detail Amount</b>
				Poetry Unbound: 50 Poems to Open Your World	10 E 2222 4300 00 300 000000	100.0000%	16.18
Amazon Capital Services, Inc.	1192400008	1P7K-FJ13-16JD	DFC	Special Education math classroom supplies from ARP Supplies & furniture budgets	03/19/2024	9100002312	1,780.41
<b>Detail Description</b>				<b>Detail Account</b>		<b>Accounting Percent</b>	<b>Detail Amount</b>
				Learniture Adjustable-Height Dry-Erase Activity Whiteboard Top Table, 48" W x 72" L Kidney, White	10 E 1200 5000 00 300 223000	100.0000%	1,780.41

## Invoice Listing

COUNTY OF GRUNDY SCHOOL DIST 111

Vendor	PO Number	Invoice Number	Batch	Description	Invoice Date	Check Number	Net Amount
Amazon Capital Services, Inc.	2032400129	1NRD-KFGN-XK91	DFC	Boys Basketball Senior Books and Folders	03/12/2024	9500000206	270.84

Detail Description	Detail Account	Accounting Percent	Detail Amount
The Obstacle Is the Way: The Timeless Art of Turning Trials into Triumph	11 E 1999 4100 30 300 910005	100.0000%	91.14
Personalized Portfolio Padfolio, Business Portfolio w Magnetic Closure Organizer Folder Leather/Canvas, Custom Notepad Holder for Resume, Professional Business Gifts   3 Colors - 6 Designs - 9 x 12	11 E 1999 4100 30 300 910005	100.0000%	29.95
Personalized Portfolio Padfolio, Business Portfolio w Magnetic Closure Organizer Folder Leather/Canvas, Custom Notepad Holder for Resume, Professional Business Gifts   3 Colors - 6 Designs - 9 x 12	11 E 1999 4100 30 300 910005	100.0000%	29.95
Personalized Portfolio Padfolio, Business Portfolio w Magnetic Closure Organizer Folder Leather/Canvas, Custom Notepad Holder for Resume, Professional Business Gifts   3 Colors - 6 Designs - 9 x 12	11 E 1999 4100 30 300 910005	100.0000%	29.95
Personalized Portfolio Padfolio, Business Portfolio w Magnetic Closure Organizer Folder Leather/Canvas, Custom Notepad Holder for Resume, Professional Business Gifts   3 Colors - 6 Designs - 9 x 12	11 E 1999 4100 30 300 910005	100.0000%	29.95
Personalized Portfolio Padfolio, Business Portfolio w Magnetic Closure Organizer Folder Leather/Canvas, Custom Notepad Holder for Resume, Professional Business Gifts   3 Colors - 6 Designs - 9 x 12	11 E 1999 4100 30 300 910005	100.0000%	29.95
Personalized Portfolio Padfolio, Business Portfolio w Magnetic Closure Organizer Folder Leather/Canvas, Custom Notepad Holder for Resume, Professional Business Gifts   3 Colors - 6 Designs - 9 x 12	11 E 1999 4100 30 300 910005	100.0000%	29.95

## Invoice Listing

COUNTY OF GRUNDY SCHOOL DIST 111

Vendor	PO Number	Invoice Number	Batch	Description	Invoice Date	Check Number	Net Amount
Amazon Capital Services, Inc.	2032400135	1NRD-KFGN-XK91	DFC	Girls Soccer Equipment	03/12/2024	9500000206	452.25

Detail Description	Detail Account	Accounting Percent	Detail Amount
Champion Sports Spring Loaded Soccer Corner Flags	11 E 1999 4100 30 300 910019	100.0000%	93.75
Sterilite 56 Qt Storage Box, Stackable Bin with Lid, Plastic Container to Organize Clothes, Blankets, Towels in Closet, Clear with White Lid, 8-Pack	11 E 1999 4100 30 300 910019	100.0000%	72.64
adidas Men's Entrada 18 Soccer Jersey	11 E 1999 4100 30 300 910019	100.0000%	22.00
Rubbermaid Cleverstore 95 Quart Clear Stackable Large Plastic Storage Containers with Lids for Office and Home Organization, Clear (4 Pack)	11 E 1999 4100 30 300 910019	100.0000%	101.99
GRIPMODE Blackout Hybrid Goalkeeper Gloves Adult and Child with Griptec® Latex Lining I Suitable in All Weather I Football Goal Protection for Children, Teenagers & Adults I Size 10	11 E 1999 4100 30 300 910019	100.0000%	84.90
BROTOU Extra Large Sports Ball Bag Mesh, 5PCS Soccer Ball Bag Heavy Duty Drawstring Bags, Team Work for Holding Basketball, Volleyball, Baseball, Swimming Gear with Shoulder Strap	11 E 1999 4100 30 300 910019	100.0000%	45.99
Flysums Plastic Hangers 50 Pack Clothes Hangers Rubber Coated, 17.5 Inches Heavy Duty Slim Dorm Hangers for Coats, Dresses, Shirts, Black- Mom's Choice Awards Winner	11 E 1999 4100 30 300 910019	100.0000%	79 17.99
Qimoo 6Pcs Orange Soccer Captain Armband, Elastic Soccer Captain Armband Adjustable Outdoor Football Player Captain Armbands Sports Captain C Arm Band for Youth and Adult	11 E 1999 4100 30 300 910019	100.0000%	12.99

Amazon Capital Services, Inc.	2032400141	1HVY-CC14-6DKK	DFC	Boys Track Supplies	03/26/2024	9500000206	62.00
-------------------------------	------------	----------------	-----	---------------------	------------	------------	-------

Detail Description	Detail Account	Accounting Percent	Detail Amount
OCM Open Reel Fiberglass Tape Measure Inch Metric Scale, Impact Resistant ABS -100 Feet, 30 Meter	11 E 1999 4100 30 300 910010	100.0000%	62.00

Amazon Capital Services, Inc.	2032400141	1KFK-NGVX-7T1X	DFC	Boys Track Supplies	04/02/2024	9500000206	37.98
-------------------------------	------------	----------------	-----	---------------------	------------	------------	-------

Detail Description	Detail Account	Accounting Percent	Detail Amount
Katzco 300 Feet (100 Meters) Open Reel Measure Tape with Retractable Blade - Open Tape Measure for Track and Field, Long Jump, Construction, Workshop, Projects, Crafts - Dual-Sided Measuring Reel	11 E 1999 4100 30 300 910010	100.0000%	37.98

## Invoice Listing

COUNTY OF GRUNDY SCHOOL DIST 111

Vendor	PO Number	Invoice Number	Batch	Description	Invoice Date	Check Number	Net Amount
Amazon Capital Services, Inc.	2032400145	1HVY-CC14-6DKK	DFC	Girls Soccer Shorts	03/26/2024	9500000206	24.28
<b>Detail Description</b>				<b>Detail Account</b>	<b>Accounting Percent</b>		<b>Detail Amount</b>
Nike Women's Soccer Dri-FIT Park III Shorts (Black, Small)				11 E 1999 4100 30 300 910019	100.0000%		24.28
Amazon Capital Services, Inc.	2032400145	1KFK-NGVX-7T1X	DFC	Girls Soccer Shorts	04/02/2024	9500000206	120.00
<b>Detail Description</b>				<b>Detail Account</b>	<b>Accounting Percent</b>		<b>Detail Amount</b>
Nike Womens Park III Shorts White S				11 E 1999 4100 30 300 910019	100.0000%		120.00

## Invoice Listing

COUNTY OF GRUNDY SCHOOL DIST 111

Vendor	PO Number	Invoice Number	Batch	Description	Invoice Date	Check Number	Net Amount
Amazon Capital Services, Inc.	2042400041	1P7K-FJ13-16JD	DFC	Orchesis clothes	03/19/2024	9500000206	1,772.16
				Detail Description	Detail Account	Accounting Percent	Detail Amount
				EFAN Summer Tops for Women Preppy Clothes 2024 Vacation Outfits Sexy Sleeveless High Neck Racerback Cropped Tank Tops Trendy Cute Clothes for Teen Girls Bright Blue	11 E 1999 4100 70 300 900039	100.0000%	104.93
				EFAN Cute Shirts for Women Vacation Outfits Summer Tops 2024 Preppy Clothes Sexy Sleeveless High Neck Racerback Cropped Tank Tops Trendy Clothes for Teen Girls Bright Blue	11 E 1999 4100 70 300 900039	100.0000%	74.95
				EFAN Cute Tops for Women Preppy Clothes Vacation Outfits 2024 Sexy Sleeveless High Neck Racerback Cropped Tank Tops Trendy Clothes for Teen Girls Bright Blue	11 E 1999 4100 70 300 900039	100.0000%	89.94
				Abardsion Women's Casual Basic Going Out Crop Tops Slim Fit Short Sleeve Crew Neck Tight T Shirts (Hot Pink, S)	11 E 1999 4100 70 300 900039	100.0000%	104.93
				Abardsion Women's Casual Basic Going Out Crop Tops Slim Fit Short Sleeve Crew Neck Tight T Shirts (Hot Pink, L)	11 E 1999 4100 70 300 900039	100.0000%	14.99
				Abardsion Women's Casual Basic Going Out Crop Tops Slim Fit Short Sleeve Crew Neck Tight T Shirts (Hot Pink, M)	11 E 1999 4100 70 300 900039	100.0000%	104.93
				Lepunuo Cargo Pants Tactical Hiking Pants for Women Stretchy Waist Black	11 E 1999 4100 70 300 900039	100.0000%	81 255.92
				Lepunuo Cargo Pants for Women Baggy Zipper Y2K Pants Light Baggy Jogger Black	11 E 1999 4100 70 300 900039	100.0000%	449.85
				Lepunuo Cargo Pants for Women High Waisted Casual Pants Baggy Stretchy Wide Leg Y2K Streetwear with 6 Pockets Black	11 E 1999 4100 70 300 900039	100.0000%	149.95
				Abardsion Women's Casual Basic Going Out Crop Tops Slim Fit Short Sleeve Crew Neck Tight T Shirts (Hot Pink, 2XL)	11 E 1999 4100 70 300 900039	100.0000%	14.99
				Cargo Pants Women Wide Leg High Waisted Button Down Straight Long Trousers Black	11 E 1999 4100 70 300 900039	100.0000%	191.94
				Lepunuo Cargo Pants Women Casual Elastic Waist Pants Baggy Y2K Pants with Pockets Womens Fall Fashion 2023 Black	11 E 1999 4100 70 300 900039	100.0000%	65.98
				HULIJA Women Rhinestone Lyrical Dance Dress Irregular Flowy Tulle Skirt Leotard Figure Ice Skating Dancewear NavyBlue Small	11 E 1999 4100 70 300 900039	100.0000%	47.97
				HULIJA Women Rhinestone Lyrical Dance Dress Irregular Flowy Tulle Skirt Leotard Figure Ice Skating Dancewear NavyBlue Medium	11 E 1999 4100 70 300 900039	100.0000%	47.97

## Invoice Listing

COUNTY OF GRUNDY SCHOOL DIST 111

Vendor	PO Number	Invoice Number	Batch	Description	Invoice Date	Check Number	Net Amount
				<b>Detail Description</b>			<b>Detail Account</b>
				<b>Detail Description</b>			<b>Accounting Percent</b>
				<b>Detail Description</b>			<b>Detail Amount</b>
				HULIJA Women Rhinestone Lyrical Dance Dress Irregular Flowy Tulle Skirt Leotard Figure Ice Skating Dancewear NavyBlue Large	11 E 1999 4100 70 300 900039	100.0000%	15.99
				Cost of shipping, not including shipping tax.	11 E 1999 4100 70 300 900039	100.0000%	36.93
Amazon Capital Services, Inc.	2042400043	1P7K-FJ13-16JD	DFC	ODASDO Lyrical Dance Costume for Women Lace Sleeveless Leotard Sheer Flowy Long Wrap Skirt 2pcs Outfit	03/19/2024	9500000206	808.79
				<b>Detail Description</b>			<b>Detail Account</b>
				<b>Detail Description</b>			<b>Accounting Percent</b>
				<b>Detail Description</b>			<b>Detail Amount</b>
				Aloodor Dresses for Women 2024 V Neck Puff Sleeve Tunic Dress Casual Black S	11 E 1999 4100 70 300 900039	100.0000%	286.99
				Aloodor Dresses for Women 2024 V Neck Puff Sleeve T Shirt Dress Fashion Black M	11 E 1999 4100 70 300 900039	100.0000%	391.35
				Aloodor Dresses for Women 2024 V Neck Puff Sleeve Summer Dress Ladies Black L	11 E 1999 4100 70 300 900039	100.0000%	78.27
				Aloodor Summer Dresses for Women 2024 V Neck Puff Sleeve Midi Dress Cute Black XXL	11 E 1999 4100 70 300 900039	100.0000%	26.09
				Aloodor Dresses for Women 2024 V Neck Puff Sleeve Cocktail Dress Sexy Black XL	11 E 1999 4100 70 300 900039	100.0000%	86.09
Amazon Capital Services, Inc.	2042400044	1HVY-CC14-6DKK	DFC	Shirts Orchesis	03/26/2024	9500000206	58.97
				<b>Detail Description</b>			<b>Detail Account</b>
				<b>Detail Description</b>			<b>Accounting Percent</b>
				<b>Detail Description</b>			<b>Detail Amount</b>
				CSDAJIO Women's Floral Lace Long Sleeve Square Neck Crop Top T Shirt Strapless Tube Top and Bolero Set Lace Black X-Small	11 E 1999 4100 70 300 900039	100.0000%	14.99
				CSDAJIO Women's Floral Lace Long Sleeve Square Neck Crop Top T Shirt Strapless Tube Top and Bolero Set Lace Black Small	11 E 1999 4100 70 300 900039	100.0000%	43.98
Amazon Capital Services, Inc.	2042400046	1PNC-JGCP-W4N7	DFC	Cart Winterguard	04/09/2024	9500000206	34.99
				<b>Detail Description</b>			<b>Detail Account</b>
				<b>Detail Description</b>			<b>Accounting Percent</b>
				<b>Detail Description</b>			<b>Detail Amount</b>
				dbest products Quik Cart Sport Collapsible Rolling Crate on Wheels for Teachers Tote Basket 80 lbs Capacity, Made from Heavy Duty Plastic Used as a Seat, Black	11 E 1999 4100 70 300 900051	100.0000%	34.99
<b>Total for Amazon Capital Services, Inc.:</b>							<b>19,401.34</b>

## Invoice Listing

COUNTY OF GRUNDY SCHOOL DIST 111

Vendor	PO Number	Invoice Number	Batch	Description	Invoice Date	Check Number	Net Amount
Apptegy, Inc.		INV21902	DFC	Thrillshare Media Subscription	04/01/2024	089046	2,000.00
<b>Detail Description</b>				<b>Detail Account</b>		<b>Accounting Percent</b>	<b>Detail Amount</b>
Thrillshare Media Subscription				10 E 2633 3000 00 300 000000		100.0000%	2,000.00
<b>Total for Apptegy, Inc.:</b>							<b>2,000.00</b>
Aqualab Water Treatment, Inc.		13166	DFC	Water Treatment Chemicals	04/01/2024	089047	375.00
<b>Detail Description</b>				<b>Detail Account</b>		<b>Accounting Percent</b>	<b>Detail Amount</b>
Water Treatment Chemicals				20 E 2540 3900 00 302 000000		100.0000%	375.00
<b>Total for Aqualab Water Treatment, Inc.:</b>							<b>375.00</b>
Aramark Uniform Services Inc		6100261585	DFC	Uniforms & Supplies	02/28/2024	089048	309.97
<b>Detail Description</b>				<b>Detail Account</b>		<b>Accounting Percent</b>	<b>Detail Amount</b>
Uniforms & Supplies				40 E 2550 3220 00 300 000000		100.0000%	309.97
Aramark Uniform Services Inc		6100264006	DFC	Uniforms and Supplies	03/05/2024	089048	56.60
<b>Detail Description</b>				<b>Detail Account</b>		<b>Accounting Percent</b>	<b>Detail Amount</b>
Uniforms & Supplies				40 E 2550 3220 00 300 000000		100.0000%	56.60
Aramark Uniform Services Inc		6100266376	DFC	Uniforms & Supplies	03/13/2024	089048	129.25
<b>Detail Description</b>				<b>Detail Account</b>		<b>Accounting Percent</b>	<b>Detail Amount</b>
Uniforms & Supplies				40 E 2550 3220 00 300 000000		100.0000%	129.25
Aramark Uniform Services Inc		6100269175	DFC	Uniforms & Supplies	03/20/2024	089048	28.20
<b>Detail Description</b>				<b>Detail Account</b>		<b>Accounting Percent</b>	<b>Detail Amount</b>
Uniforms & Supplies				40 E 2550 3220 00 300 000000		100.0000%	28.20
Aramark Uniform Services Inc		6100271333	DFC	Uniforms & Supplies	03/27/2024	089048	129.15
<b>Detail Description</b>				<b>Detail Account</b>		<b>Accounting Percent</b>	<b>Detail Amount</b>
Uniforms & Supplies				40 E 2550 3220 00 300 000000		100.0000%	129.15
Aramark Uniform Services Inc		6100273577	DFC	Uniforms & Supplies	04/03/2024	089048	28.20
<b>Detail Description</b>				<b>Detail Account</b>		<b>Accounting Percent</b>	<b>Detail Amount</b>
Uniforms & Supplies				40 E 2550 3220 00 300 000000		100.0000%	28.20
<b>Total for Aramark Uniform Services Inc:</b>							<b>681.37</b>

## Invoice Listing

COUNTY OF GRUNDY SCHOOL DIST 111

Vendor	PO Number	Invoice Number	Batch	Description	Invoice Date	Check Number	Net Amount
ASLTA	2042400045	14501	DFC	ASLHS Embossed Seal and Honor Cords	03/22/2024	23590	608.50
<b>Detail Description</b>				<b>Detail Account</b>		<b>Accounting Percent</b>	<b>Detail Amount</b>
ASLHS Embossed Seal				11 E 1999 4100 70 300 900061		100.0000%	46.00
ASLHS Stole				11 E 1999 4100 70 300 900061		100.0000%	374.00
ASLHS Honor Cord				11 E 1999 4100 70 300 900061		100.0000%	188.50
<b>Total for ASLTA:</b>							<b>608.50</b>
Avalos, Yadira		Parking Permit Refund	DFC	Parking Permit Refund	03/20/2024	089049	33.00
<b>Detail Description</b>				<b>Detail Account</b>		<b>Accounting Percent</b>	<b>Detail Amount</b>
Parking Permit Refund				10 R 1724 0000 00 000 000000		100.0000%	33.00
<b>Total for Avalos, Yadira:</b>							<b>33.00</b>
Bannon Exterminating		150503	DFC	Exterminating	03/29/2024	089050	200.00
<b>Detail Description</b>				<b>Detail Account</b>		<b>Accounting Percent</b>	<b>Detail Amount</b>
Exterminating				20 E 2540 3000 00 302 000003		100.0000%	200.00
Bannon Exterminating		150503A	DFC	Exterminating	03/29/2024	089050	200.00
<b>Detail Description</b>				<b>Detail Account</b>		<b>Accounting Percent</b>	<b>Detail Amount</b>
Exterminating				20 E 2540 3000 00 300 000005		100.0000%	200.00
<b>Total for Bannon Exterminating:</b>							<b>400.00</b>
Batavia High School		2024 Windmill City	DFC	2024 Windmill City Weekend	04/05/2024	23591	250.00
<b>Detail Description</b>				<b>Detail Account</b>		<b>Accounting Percent</b>	<b>Detail Amount</b>
2024 Windmill City Weekend				11 E 1999 4100 30 300 910016		100.0000%	250.00
<b>Total for Batavia High School:</b>							<b>250.00</b>
Bates Water Solutions	0002400052	110287	DFC	Installation of Water Softener	04/04/2024	089051	40,336.73
<b>Detail Description</b>				<b>Detail Account</b>		<b>Accounting Percent</b>	<b>Detail Amount</b>
Install & Start up Services for new water softener per quote				20 E 2540 3230 00 302 000000		100.0000%	40,336.73
<b>Total for Bates Water Solutions:</b>							<b>40,336.73</b>
Bayer Piano Service		417	DFC	Piano Tuning	03/21/2024	089052	200.00
<b>Detail Description</b>				<b>Detail Account</b>		<b>Accounting Percent</b>	<b>Detail Amount</b>
Piano Tuning				10 E 1130 3230 12 300 000001		100.0000%	200.00
<b>Total for Bayer Piano Service:</b>							<b>200.00</b>

## Invoice Listing

COUNTY OF GRUNDY SCHOOL DIST 111

Vendor	PO Number	Invoice Number	Batch	Description	Invoice Date	Check Number	Net Amount
Big Frog Custom T-Shirts & More		ORD-55126	DFC	Orchesis apparel	04/02/2024	23592	1,628.02
				<b>Detail Description</b>			<b>Detail Account</b>
				Apparel			11 E 1999 4100 70 300 900039
							100.0000%
							1,628.02
<b>Total for Big Frog Custom T-Shirts &amp; More:</b>							<b>1,628.02</b>
Black Knight Industries		22242	DFC	Supplies	03/14/2024	9100002313	2,500.00
				<b>Detail Description</b>			<b>Detail Account</b>
				Supplies			10 E 1500 4100 70 300 000025
							100.0000%
							2,500.00
Black Knight Industries		22242	DFC	Supplies	03/14/2024	9500000207	527.70
				<b>Detail Description</b>			<b>Detail Account</b>
				Supplies			11 E 1999 4100 70 300 900032
							100.0000%
							527.70
<b>Total for Black Knight Industries:</b>							<b>3,027.70</b>
Blick Art Materials	1152400085	2678382	DFC	Art PHOTO supplies	03/15/2024	9100002314	1,424.73
				<b>Detail Description</b>			<b>Detail Account</b>
				20508-4809 PRISMACOLOR CLR PNCL ASRTD 48 CT SET			10 E 1130 4100 02 300 000000
				07008-5620 BLICK CANVAS PANEL 16X20 5PK			10 E 1130 4100 02 300 000000
				17269-1423 BLK MATBOARD PACKS 9X12 40/PK			10 E 1130 4100 02 300 000000
				20702-4035-12 PIGMA MICRON PEN 08 YLL .50MM			10 E 1130 4100 02 300 000000
				20702-4014-12 PIGMA MICRON PEN 05 YLW .45MM			10 E 1130 4100 02 300 000000
				20702-4515 PIGMA MICRON PEN 05 ORG .45MM			10 E 1130 4100 02 300 000000
				20702-4512 PIGMA MICRON PEN 005 ORG .20MM			10 E 1130 4100 02 300 000000
				20508-3041 PRISMACOLOR CLR PNCL 930 MAGENTA			10 E 1130 4100 02 300 000000
				20508-7241 PRISMACOLOR CLR PNCL 909 GRASS GRN			10 E 1130 4100 02 300 000000
				20508-5231 PRISMACOLOR CLR PNCL 902 ULTRAMARINE			10 E 1130 4100 02 300 000000
				20508-3161 PRISMACOLOR CLR PNCL 924 CRIMSON RED			10 E 1130 4100 02 300 000000
				20508-4261 PRISMACOLOR CLR PNCL 916 CANARY YELLOW			10 E 1130 4100 02 300 000000

## Invoice Listing

COUNTY OF GRUNDY SCHOOL DIST 111

Vendor	PO Number	Invoice Number	Batch	Description	Invoice Date	Check Number	Net Amount
Blick Art Materials	1152400086	2674316	DFC	Glaze for Art Room Central Campus	03/14/2024	9100002314	1,836.96
Detail Description				Detail Account	Accounting Percent		Detail Amount
30579-3376 TEACHRS PALTT LT GLZ TPL-59 RUBY PINT				10 E 1130 4100 02 300 000000	100.0000%		58.88
30579-1106 TEACHRS PALTT LT GLZ TPL-27 ZIRCON PINT				10 E 1130 4100 02 300 000000	100.0000%		58.88
30579-1526 TEACHRS PALTT LT GLZ TPL-5 QUARTZ PINT				10 E 1130 4100 02 300 000000	100.0000%		58.88
30413-3346 LG LIQ GLOSS GLAZE LG-50 MAROON PT				10 E 1130 4100 02 300 000000	100.0000%		72.42
30413-7156 LG LIQ GLOSS GLAZE LG-46 LEAF GRN PT				10 E 1130 4100 02 300 000000	100.0000%		71.32
30413-5016 LG LIQ GLOSS GLAZE LG-24 LT BLU PT				10 E 1130 4100 02 300 000000	100.0000%		35.66
30413-3756 LG LIQ GLOSS GLAZE LG-59 HOT RED PT				10 E 1130 4100 02 300 000000	100.0000%		48.28
30413-4616 LG LIQ GLOSS GLAZE LG-67 FIRE ORG PT				10 E 1130 4100 02 300 000000	100.0000%		48.28
30413-4946 LG LIQ GLOSS GLAZE LG-68 VIVD ORG PT				10 E 1130 4100 02 300 000000	100.0000%		48.28
30482-3706 BLICK GLOSS GLAZE SNAPDRAGON PT				10 E 1130 4100 02 300 000000	100.0000%		32.10
30482-7426 BLICK GLOSS GLAZE SEAFOAM PT				10 E 1130 4100 02 300 000000	100.0000%		42.80
30482-8556 BLICK GLOSS GLAZE SAND DUNE PT				10 E 1130 4100 02 300 000000	100.0000%		21.40
30482-8106 BLICK GLOSS GLAZE MILK CHOC PT				10 E 1130 4100 02 300 000000	100.0000%		21.40
30482-6036 BLICK GLOSS GLAZE LILAC PT				10 E 1130 4100 02 300 000000	100.0000%		32.10
30482-5106 BLICK GLOSS GLAZE LAGOON PT				10 E 1130 4100 02 300 000000	100.0000%		21.40
30482-5016 BLICK GLOSS GLAZE HYDRANGEA PT				10 E 1130 4100 02 300 000000	100.0000%		21.40
30482-4926 BLICK GLOSS GLAZE SUNFLOWER PT				10 E 1130 4100 02 300 000000	100.0000%		21.40
30482-7246 BLICK GLOSS GLAZE GRASS GRN PT				10 E 1130 4100 02 300 000000	100.0000%		21.40
30482-3066 BLICK GLOSS GLAZE GRAPFRUIT PT				10 E 1130 4100 02 300 000000	100.0000%		42.80
30482-7176 BLICK GLOSS GLAZE GRANNY SMITH PT				10 E 1130 4100 02 300 000000	100.0000%		21.40
30482-7056 BLICK GLOSS GLAZE EMRLD ISLE PT				10 E 1130 4100 02 300 000000	100.0000%		32.10
30482-2606 BLICK GLOSS GLAZE ELEPHANT GRAY PT				10 E 1130 4100 02 300 000000	100.0000%		21.40
30482-7916 BLICK GLOSS GLAZE CLOVER PT				10 E 1130 4100 02 300 000000	100.0000%		21.40
30482-3226 BLICK GLOSS GLAZE CARDNL PT				10 E 1130 4100 02 300 000000	100.0000%		32.10
30482-4076 BLICK GLOSS GLAZE BUTTERSCTCH PT				10 E 1130 4100 02 300 000000	100.0000%		21.40
30482-3196 BLICK GLOSS GLAZE CANDY APPLE PT				10 E 1130 4100 02 300 000000	100.0000%		64.20
30482-3716 BLICK GLOSS GLAZE BLUSH PT				10 E 1130 4100 02 300 000000	100.0000%		42.80
30443-5596 ELEMENTS GLAZES BLUE GROTTTO 16OZ				10 E 1130 4100 02 300 000000	100.0000%		46.64
30443-7236 ELEMENTS GLAZES AZTEC JADE PT				10 E 1130 4100 02 300 000000	100.0000%		23.32
30443-5936 ELEMENTS GLAZES BLUEGRASS PINT				10 E 1130 4100 02 300 000000	100.0000%		62.40
30443-8576 ELEMENTS GLAZES AUTUMN PT				10 E 1130 4100 02 300 000000	100.0000%		46.64

## Invoice Listing

COUNTY OF GRUNDY SCHOOL DIST 111

Vendor	PO Number	Invoice Number	Batch	Description	Invoice Date	Check Number	Net Amount
				Detail Description	Detail Account	Accounting Percent	Detail Amount
				30443-4916 ELEMENTS GLAZES AMBER ASH 16OZ	10 E 1130 4100 02 300 000000	100.0000%	23.32
				30443-9516 ELEMENTS GLAZES COPPER ADVNTRN 16OZ	10 E 1130 4100 02 300 000000	100.0000%	46.64
				30443-7316 ELEMENTS GLAZES DARK AMETHYST PT	10 E 1130 4100 02 300 000000	100.0000%	23.32
				30443-8406 ELEMENTS GLAZES GINGER ROOT PT	10 E 1130 4100 02 300 000000	100.0000%	23.32
				30443-5266 ELEMENTS GLAZES LAPIS LAGOON PT	10 E 1130 4100 02 300 000000	100.0000%	23.32
				30443-5336 ELEMENTS GLAZES LAVENDER FLOWER 16OZ	10 E 1130 4100 02 300 000000	100.0000%	23.32
				30443-7936 ELEMENTS GLAZES MLCHT GRN PT	10 E 1130 4100 02 300 000000	100.0000%	46.64
				30443-5546 ELEMENTS GLAZES MIRROR BLUE PT	10 E 1130 4100 02 300 000000	100.0000%	46.64
				30443-8016 ELEMENTS GLAZES MUDSLIDE 16OZ	10 E 1130 4100 02 300 000000	100.0000%	23.32
				30443-7946 ELEMENTS GLAZES PINE NEEDLES PINT	10 E 1130 4100 02 300 000000	100.0000%	62.40
				30443-1096 ELEMENTS GLAZES PATINA PT	10 E 1130 4100 02 300 000000	100.0000%	23.32
				30443-8336 ELEMENTS GLAZES RARE EARTH PT	10 E 1130 4100 02 300 000000	100.0000%	46.64
				30443-8556 ELEMENTS GLAZES SAHARA SANDS PT	10 E 1130 4100 02 300 000000	100.0000%	23.32
				30443-7846 ELEMENTS GLAZES SEA GREEN PT	10 E 1130 4100 02 300 000000	100.0000%	46.64
				30443-2606 ELEMENTS GLAZES SLATE PT	10 E 1130 4100 02 300 000000	100.0000%	23.32
				30443-7526 ELEMENTS GLAZES SPANISH MOSS 16OZ	10 E 1130 4100 02 300 000000	100.0000%	46.64
				30443-5926 ELEMENTS GLAZES STRMY BL PT	10 E 1130 4100 02 300 000000	100.0000%	46.64
				30443-8386 ELEMENTS GLAZES TOASTED ALMOND PT	10 E 1130 4100 02 300 000000	100.0000%	23.32
				<b>Total for Blick Art Materials:</b>			<b>3,261.69</b>

Blue Cross Blue Shield of IL - Dept. 1134	550745780178	DFC	March Insurance	03/31/2024	1312	427,020.23
---	--------------	-----	-----------------	------------	------	------------

Detail Description	Detail Account	Accounting Percent	Detail Amount
March coverage	10 E 1130 2220 00 000 000000	100.0000%	388,147.01
March Coverage	20 E 1130 2220 00 000 000000	100.0000%	13,356.32
March Coverage	40 E 1130 2220 00 000 000000	100.0000%	2,384.86
March Coverage	80 E 1130 2220 00 000 000000	100.0000%	8,200.15
March Coverage	10 E 1130 2230 00 000 000000	100.0000%	13,810.30
March Coverage	20 E 1130 2230 00 000 000000	100.0000%	551.53
March Coverage	40 E 1130 2230 00 000 000000	100.0000%	243.70
March Coverage	80 E 1130 2230 00 000 000000	100.0000%	326.36

**Total for Blue Cross Blue Shield of IL - Dept. 1134: 427,020.23**

## Invoice Listing

COUNTY OF GRUNDY SCHOOL DIST 111

Vendor	PO Number	Invoice Number	Batch	Description	Invoice Date	Check Number	Net Amount
BMO Harris		4/5/24 Statement	DFC	4/5/24 Statement	04/05/2024	8200000045	15,901.48
Detail Description		Detail Account		Accounting Percent	Detail Amount		
Haase - FSP Illinois Assoc		40 E 2550 6400 00 000 000000		100.0000%	200.00		
Haase - IL Tollway		40 E 2552 4100 00 300 000001		100.0000%	4.50		
Haase - Jewel		40 E 2552 4100 00 300 000000		100.0000%	158.02		
Haase - Dollar General		40 E 2552 4100 00 300 000000		100.0000%	9.56		
Haase - Dollar General		40 E 2552 4100 00 300 000000		100.0000%	8.77		
Haase - IL Tollway		40 E 2552 4100 00 300 000001		100.0000%	11.60		
Haase - IL Tollway		40 E 2552 4100 00 300 000001		100.0000%	17.25		
Haase - IL Tollway		40 E 2552 4100 00 300 000001		100.0000%	31.60		
Shiffbauer - Plainfield Shorewood Area Chamber of Commerce		10 E 2321 6400 00 300 000000		100.0000%	55.00		
Troy - Partition Plus		20 E 2540 4100 00 302 000000		100.0000%	62.50		
Troy - Choice Builder Solutions		20 E 2540 4100 00 302 000000		100.0000%	341.60		
Troy - IMotion		20 E 2540 4100 00 300 000000		100.0000%	46.86		
Troy - Runnings		10 E 1130 4100 50 300 000000		100.0000%	699.98		
Trans 1 - Hampton INN		10 E 1500 3320 70 300 000000		100.0000%	499.80		
Trans 1 - MCHSPard		10 E 1500 4100 70 300 000021		100.0000%	2,407.70		
Trans 2 - Jewel		10 E 2310 4100 00 300 000000		100.0000%	41.88		
Trans 2 - Joann		10 E 1420 4100 09 300 000000		100.0000%	713.87		
Trans 2 - MCHS PCard		10 E 1500 4100 70 300 000021		100.0000%	351.50		
Trans 3 - Dominos		10 E 1500 4100 70 300 000066		100.0000%	55.93		
Domino's		10 E 1500 4100 70 300 000066		100.0000%	71.91		
Dominos		10 E 1500 4100 70 300 000066		100.0000%	25.47		
Dominos		10 E 1500 4100 70 300 000066		100.0000%	22.28		
Trans 4 - Papa Johns		10 E 1500 3320 70 300 000000		100.0000%	157.52		
Trans 4 - Jimmy Johns		10 E 1500 3320 70 300 000000		100.0000%	75.90		
Trans 4 - Shell Oil		10 E 1500 3320 70 300 000000		100.0000%	90.87		
Trans 5 - MCHS PCard		10 E 1500 4100 70 300 000021		100.0000%	4,756.47		
Brown - MCHS Pcard		10 E 1500 4100 70 300 000021		100.0000%	2,419.02		
Brown - Fat Ricky's		10 E 1500 3900 30 300 000000		100.0000%	274.07		
Holden - MCHS PCard		10 E 1500 4100 70 300 000021		100.0000%	2,290.05		

## Invoice Listing

COUNTY OF GRUNDY SCHOOL DIST 111

Vendor	PO Number	Invoice Number	Batch	Description	Invoice Date	Check Number	Net Amount
BMO Harris	1002400019	4/5/24 Statement	DFC	P-Card	04/05/2024	8200000045	1,713.00
<b>Detail Description</b>		<b>Detail Account</b>		<b>Accounting Percent</b>		<b>Detail Amount</b>	
Donut Den		10 E 2410 4100 00 300 000001		100.0000%		59.05	
Jimmy Johns		10 E 2410 4100 00 300 000001		100.0000%		93.49	
Medici Dinner		10 E 2410 4100 00 300 000001		100.0000%		225.46	
Courtyard Hotel		10 E 2210 3120 00 300 000000		100.0000%		194.88	
Courtyard Hotel		10 E 2210 3120 00 300 000000		100.0000%		194.88	
Courtyard Hotel		10 E 2210 3120 00 300 000000		100.0000%		194.88	
Courtyard Hotel		10 E 2210 3120 00 300 000000		100.0000%		194.88	
Courtyard Hotel		10 E 2210 3120 00 300 000000		100.0000%		194.88	
Courtyard Hotel		10 E 2210 3120 00 300 000000		100.0000%		194.88	
Giordanos Pizza		10 E 2410 4100 00 300 000001		100.0000%		165.72	
BMO Harris	1032400525	4/5/24 Statement	DFC	Boys Track M-F Athletic	04/05/2024	8200000045	74.30
<b>Detail Description</b>		<b>Detail Account</b>		<b>Accounting Percent</b>		<b>Detail Amount</b>	
M-F Athletic		10 E 1500 5400 30 300 000004		100.0000%		74.30	
BMO Harris	1032400541	4/5/24 Statement	DFC	Lunch for coaches at SPC Girls Track Invite	04/05/2024	8200000045	269.97
<b>Detail Description</b>		<b>Detail Account</b>		<b>Accounting Percent</b>		<b>Detail Amount</b>	
Lunch for coaches at SPC Girls Track Invite		10 E 1500 3900 30 300 000000		100.0000%		269.97	
BMO Harris	1032400542	4/5/24 Statement	DFC	Breakfast for coaches at SPC Girls Track Invite	04/05/2024	8200000045	129.93
<b>Detail Description</b>		<b>Detail Account</b>		<b>Accounting Percent</b>		<b>Detail Amount</b>	
Breakfast for coaches at SPC Girls Track Invite		10 E 1500 3900 30 300 000000		100.0000%		129.93	
BMO Harris	1032400543	4/5/24 Statement	DFC	Girls Track Illinois Top Times Invitational	04/05/2024	8200000045	230.00
<b>Detail Description</b>		<b>Detail Account</b>		<b>Accounting Percent</b>		<b>Detail Amount</b>	
Girls Track Illinois Top Times Invitational		10 E 1500 3900 30 300 000000		100.0000%		230.00	

## Invoice Listing

COUNTY OF GRUNDY SCHOOL DIST 111

Vendor	PO Number	Invoice Number	Batch	Description	Invoice Date	Check Number	Net Amount
BMO Harris	1042400034	4/5/24 Statement	DFC	March Board Statement P-card	04/05/2024	8200000045	3,710.83
				<b>Detail Description</b>	<b>Detail Account</b>	<b>Accounting Percent</b>	<b>Detail Amount</b>
				Jewel	10 E 1500 4100 70 300 000006	100.0000%	69.46
				Fat Ricky's	10 E 1500 3320 70 300 000001	100.0000%	71.63
				Amazon	10 E 1500 4100 70 300 000004	100.0000%	86.95
				Amazon	10 E 1500 4100 70 300 000004	100.0000%	79.96
				Country Inn & Suites	10 E 1500 3320 70 300 000000	100.0000%	2,093.59
				Jewel 10E	10 E 1500 4100 70 300 000004	100.0000%	81.89
				Target Musical Supplies	10 E 1500 4100 70 300 000004	100.0000%	61.99
				Walgreens Musical Supplies	10 E 1500 4100 70 300 000004	100.0000%	41.17
				UPS STORE #15	10 E 1500 3000 70 300 000000	100.0000%	148.26
				UPS STORE #16	10 E 1500 3000 70 300 000000	100.0000%	156.07
				INFINITY #8	10 E 1500 3000 70 300 000000	100.0000%	711.86
				CAMPUS SUPPLY#18	10 E 1500 6400 70 300 000002	100.0000%	108.00
BMO Harris	1052400041	4/5/24 Statement	DFC	March 2024 P- Card purchases for the Director of Student Services, Joseph V. Pacetti	04/05/2024	8200000045	1,070.38
				<b>Detail Description</b>	<b>Detail Account</b>	<b>Accounting Percent</b>	<b>Detail Amount</b>
				3/8/2024-Hinckley Springs for South and Central Nurses Water Supply	10 E 2134 4100 00 300 000000	100.0000%	94.68
				IDFPR- C. Daurer license renewal	10 E 2210 3000 00 300 000002	100.0000%	81.80
				IDFPR-A. Muniz license renewal	10 E 2210 3000 00 300 000002	100.0000%	81.80
				Mender Hotel San Antonio Texas- Accommodations for L. Murdie & R. Krieger for 3 day special education convention of exceptional children	10 E 2210 3000 00 300 000002	100.0000%	812.10
BMO Harris	1082400022	4/5/24 Statement	DFC	Morris Bakery Donuts for Staff- PSAT/SAT	04/05/2024	8200000045	300.00
				<b>Detail Description</b>	<b>Detail Account</b>	<b>Accounting Percent</b>	<b>Detail Amount</b>
				Morris Bakery Donuts PSAT/SAT	10 E 1130 4100 00 300 000002	100.0000%	300.00
BMO Harris	1112400027	4/5/24 Statement	DFC	Membership subscriptions for two teachers	04/05/2024	8200000045	59.00
				<b>Detail Description</b>	<b>Detail Account</b>	<b>Accounting Percent</b>	<b>Detail Amount</b>
				Two basic memberships to NCTM for teachers.	10 E 2210 3000 11 300 000000	100.0000%	59.00
						<b>Total for BMO Harris:</b>	<b>23,458.89</b>

## Invoice Listing

COUNTY OF GRUNDY SCHOOL DIST 111

Vendor	PO Number	Invoice Number	Batch	Description	Invoice Date	Check Number	Net Amount
Boe, Kristi A		March '24 Cellphone	DFC	March '24 Cellphone Reimbursement	04/17/2024	089053	100.00
<b>Detail Description</b>				<b>Detail Account</b>		<b>Accounting Percent</b>	<b>Detail Amount</b>
Cell Phone Reimbursement				20 E 2540 3400 00 300 000001		100.0000%	100.00
<b>Total for Boe, Kristi A:</b>							<b>100.00</b>
BSN Sports Inc	2032400093	924869997	DFC	Football Travel Bags	02/22/2024	23593	596.00
<b>Detail Description</b>				<b>Detail Account</b>		<b>Accounting Percent</b>	<b>Detail Amount</b>
Team Equipment Bag - Black				11 E 1999 4100 30 300 910014		100.0000%	560.00
Freight				11 E 1999 4100 30 300 910014		100.0000%	36.00
BSN Sports Inc	2032400094	924741874	DFC	Football - Create Your Own G Series Package	02/08/2024	23593	990.00
<b>Detail Description</b>				<b>Detail Account</b>		<b>Accounting Percent</b>	<b>Detail Amount</b>
Create Your Own G Series Package				11 E 1999 4100 30 300 910014		100.0000%	990.00
BSN Sports Inc	2032400103	924869999	DFC	Boys Volleyball Gear	02/22/2024	23593	540.65
<b>Detail Description</b>				<b>Detail Account</b>		<b>Accounting Percent</b>	<b>Detail Amount</b>
Nike Club Pullover Fleece Hoodie Item # - NKCJ1611 010 - BLACK MED LRG 1 4				11 E 1999 4100 30 300 910011		100.0000%	284.95
Nike Women's Dry Franchise Polo Item # - NKCU3206 820 - TM ORNG MED 3				11 E 1999 4100 30 300 910011		100.0000%	137.97
Nike Dry Franchise Polo Item # - NKCI4470 891 - TM ORNG MED LRG 1 1				11 E 1999 4100 30 300 910011		100.0000%	91.98
Freight				11 E 1999 4100 30 300 910011		100.0000%	25.75
BSN Sports Inc	2032400110	924869998	DFC	Girls Wrestling State T-Shirts	02/22/2024	23593	450.00
<b>Detail Description</b>				<b>Detail Account</b>		<b>Accounting Percent</b>	<b>Detail Amount</b>
SAFE ORG-HEAVY COTTON 100% COTTON T-SHIRT SML MED LRG XLG XXL 3XL 4 10 5 8 2 1				11 E 1999 4100 30 300 910044		100.0000%	450.00
BSN Sports Inc	1032400381	924356094	DFC	Boys Tennis Balls	12/22/2023	089054	997.02
<b>Detail Description</b>				<b>Detail Account</b>		<b>Accounting Percent</b>	<b>Detail Amount</b>
Boys Tennis Balls				10 E 1500 4100 30 300 000002		100.0000%	972.00
Freight				10 E 1500 4100 30 300 000002		100.0000%	25.02

## Invoice Listing

COUNTY OF GRUNDY SCHOOL DIST 111

Vendor	PO Number	Invoice Number	Batch	Description	Invoice Date	Check Number	Net Amount	
BSN Sports Inc	1032400459	924687889	DFC	Girls Track Uniforms	02/02/2024	089054	500.00	
<b>Detail Description</b>				<b>Detail Account</b>		<b>Accounting Percent</b>		<b>Detail Amount</b>
NIKE Boy Cut Track Shorts				10 E 1500 4100 30 300 000034		100.0000%		500.00
BSN Sports Inc	1032400459	924897536	DFC	Girls Track Uniforms	02/26/2024	089054	862.50	
<b>Detail Description</b>				<b>Detail Account</b>		<b>Accounting Percent</b>		<b>Detail Amount</b>
BSN Custom Track Singlet				10 E 1500 4100 30 300 000034		100.0000%		862.50
BSN Sports Inc	1032400501	924830474	DFC	Baseball Tarp	02/19/2024	089054	660.00	
<b>Detail Description</b>				<b>Detail Account</b>		<b>Accounting Percent</b>		<b>Detail Amount</b>
Circular Home Plate Cover 26"				10 E 1500 4100 30 300 000010		100.0000%		600.00
Freight				10 E 1500 4100 30 300 000010		100.0000%		60.00
BSN Sports Inc	1032400512	924920185	DFC	Tennis Net	02/28/2024	089054	252.99	
<b>Detail Description</b>				<b>Detail Account</b>		<b>Accounting Percent</b>		<b>Detail Amount</b>
EDWARDS 30LS DOUBLE CENTER - TNET30LSDC				10 E 1500 4100 30 300 000008		100.0000%		229.99
Freight				10 E 1500 4100 30 300 000008		100.0000%		23.00
<b>Total for BSN Sports Inc:</b>							<b>5,849.16</b>	
C.R. Leonard Plumbing & Heating, Inc.		53980	DFC	Replaced toilet	03/07/2024	089055	800.45	
<b>Detail Description</b>				<b>Detail Account</b>		<b>Accounting Percent</b>		<b>Detail Amount</b>
Replaced Toilet				20 E 2540 3230 00 302 000000		100.0000%		800.45
<b>Total for C.R. Leonard Plumbing &amp; Heating, Inc.:</b>							<b>800.45</b>	
Camelot Therapeutic Schools, LLC		INV186437	DFC	Tuition	02/29/2024	089056	5,014.38	
<b>Detail Description</b>				<b>Detail Account</b>		<b>Accounting Percent</b>		<b>Detail Amount</b>
Tuition				10 E 1912 6700 00 300 000000		100.0000%		5,014.38
Camelot Therapeutic Schools, LLC		INV1896321	DFC	Tuition	03/06/2024	089056	33,053.84	
<b>Detail Description</b>				<b>Detail Account</b>		<b>Accounting Percent</b>		<b>Detail Amount</b>
Tuition				10 E 1912 6700 00 300 000000		100.0000%		33,053.84
<b>Total for Camelot Therapeutic Schools, LLC:</b>							<b>38,068.22</b>	
Canna Law Offices PC		1727	DFC	March Fees	04/01/2024	9100002315	12.50	
<b>Detail Description</b>				<b>Detail Account</b>		<b>Accounting Percent</b>		<b>Detail Amount</b>
March Fees				80 E 2310 3180 00 300 000000		100.0000%		12.50
<b>Total for Canna Law Offices PC:</b>							<b>12.50</b>	

## Invoice Listing

COUNTY OF GRUNDY SCHOOL DIST 111

Vendor	PO Number	Invoice Number	Batch	Description	Invoice Date	Check Number	Net Amount
Capital One - Walmart Community	1092400023	1654577574	DFC	Open PO	03/14/2024	089057	3.78
<b>Detail Description</b>				<b>Detail Account</b>		<b>Accounting Percent</b>	<b>Detail Amount</b>
Open PO				10 E 1420 4100 09 300 000000		100.0000%	3.78
Capital One - Walmart Community	1092400023	1654577574	DFC	Open PO	03/18/2024	089057	164.85
<b>Detail Description</b>				<b>Detail Account</b>		<b>Accounting Percent</b>	<b>Detail Amount</b>
Open PO				10 E 1420 4100 09 300 000000		100.0000%	164.85
Capital One - Walmart Community	1092400023	1654577574	DFC	Open PO	03/21/2024	089057	130.08
<b>Detail Description</b>				<b>Detail Account</b>		<b>Accounting Percent</b>	<b>Detail Amount</b>
Open PO				10 E 1420 4100 09 300 000000		100.0000%	130.08
<b>Total for Capital One - Walmart Community:</b>							<b>298.71</b>
Carlin Supply	1092400020	5010419-00	DFC	OPEN PO	03/21/2024	089058	465.64
<b>Detail Description</b>				<b>Detail Account</b>		<b>Accounting Percent</b>	<b>Detail Amount</b>
OPEN PO - Ag supply				10 E 1401 4100 01 300 000000		100.0000%	465.64
Carlin Supply	1092400020	5010911-00	DFC	OPEN PO	03/13/2024	089058	97.72
<b>Detail Description</b>				<b>Detail Account</b>		<b>Accounting Percent</b>	<b>Detail Amount</b>
OPEN PO - Ag supply				10 E 1401 4100 01 300 000000		100.0000%	97.72
<b>Total for Carlin Supply:</b>							<b>563.36</b>
Carrier Corporation		90348976	DFC	HVAC Maintenance	03/01/2024	089059	1,487.50
<b>Detail Description</b>				<b>Detail Account</b>		<b>Accounting Percent</b>	<b>Detail Amount</b>
HVAC Maintenance				20 E 2540 3230 00 302 000001		100.0000%	1,487.50
Carrier Corporation		90351143	DFC	Boiler repair	03/12/2024	089059	1,503.00
<b>Detail Description</b>				<b>Detail Account</b>		<b>Accounting Percent</b>	<b>Detail Amount</b>
Boiler Repair				20 E 2540 3230 00 302 000001		100.0000%	1,503.00
Carrier Corporation		90351150	DFC	Investigate Leaking Hot Water Heater	03/12/2024	089059	1,053.00
<b>Detail Description</b>				<b>Detail Account</b>		<b>Accounting Percent</b>	<b>Detail Amount</b>
Investigate Hot Water Heater				20 E 2540 3230 00 302 000001		100.0000%	1,053.00
Carrier Corporation		90351941	DFC	HVAC Repairs	03/15/2024	089059	1,953.00
<b>Detail Description</b>				<b>Detail Account</b>		<b>Accounting Percent</b>	<b>Detail Amount</b>
HVAC Repairs				20 E 2540 3230 00 302 000001		100.0000%	1,953.00

## Invoice Listing

COUNTY OF GRUNDY SCHOOL DIST 111

Vendor	PO Number	Invoice Number	Batch	Description	Invoice Date	Check Number	Net Amount	
Carrier Corporation		90352919	DFC	B-AHU-Line Repair	03/21/2024	089059	9,831.00	
<b>Detail Description</b>				<b>Detail Account</b>		<b>Accounting Percent</b>		<b>Detail Amount</b>
B-AHU Line Repair				20 E 2540 3230 00 302 000001		100.0000%		9,831.00
<b>Total for Carrier Corporation:</b>							<b>15,827.50</b>	
Catapult Sports Inc.	2032400140	INV48220	DFC	Football Vests	03/21/2024	23594	160.00	
<b>Detail Description</b>				<b>Detail Account</b>		<b>Accounting Percent</b>		<b>Detail Amount</b>
Catapult One M Vest				11 E 1999 4100 30 300 910014		100.0000%		80.00
Catapult One L Vest				11 E 1999 4100 30 300 910014		100.0000%		40.00
Catapult One XL Vest				11 E 1999 4100 30 300 910014		100.0000%		40.00
<b>Total for Catapult Sports Inc.:</b>							<b>160.00</b>	
Central States Bus Sales		IN611005	DFC	Supplies	03/19/2024	089060	157.00	
<b>Detail Description</b>				<b>Detail Account</b>		<b>Accounting Percent</b>		<b>Detail Amount</b>
Switch, Park Brake, Foot				40 E 2552 4100 00 300 000001		100.0000%		157.00
Central States Bus Sales		IN612709	DFC	Supplies	04/03/2024	089060	679.18	
<b>Detail Description</b>				<b>Detail Account</b>		<b>Accounting Percent</b>		<b>Detail Amount</b>
Supplies				40 E 2552 4100 00 300 000001		100.0000%		679.18
<b>Total for Central States Bus Sales:</b>							<b>836.18</b>	
Chasing T's Inkooperated, LLC		3841	DFC	TShirts & Sweatshirts	02/29/2024	23595	1,249.75	
<b>Detail Description</b>				<b>Detail Account</b>		<b>Accounting Percent</b>		<b>Detail Amount</b>
TShirts & Sweatshirts				11 E 1999 4100 30 300 910021		100.0000%		1,249.75
Chasing T's Inkooperated, LLC		3857	DFC	Foundation items	03/19/2024	089061	546.50	
<b>Detail Description</b>				<b>Detail Account</b>		<b>Accounting Percent</b>		<b>Detail Amount</b>
Foundation items				10 E 2310 4100 00 300 000001		100.0000%		546.50
Chasing T's Inkooperated, LLC		3858	DFC	Banners	03/19/2024	089061	388.00	
<b>Detail Description</b>				<b>Detail Account</b>		<b>Accounting Percent</b>		<b>Detail Amount</b>
Sponsor Banners				10 E 2633 3500 00 300 000000		100.0000%		388.00
<b>Total for Chasing T's Inkooperated, LLC:</b>							<b>2,184.25</b>	

## Invoice Listing

COUNTY OF GRUNDY SCHOOL DIST 111

Vendor	PO Number	Invoice Number	Batch	Description	Invoice Date	Check Number	Net Amount	
CIT Trucks		34148	DFC	Bus 55 Repairs	03/13/2024	089062	3,516.78	
				<b>Detail Description</b>	<b>Detail Account</b>		<b>Accounting Percent</b>	<b>Detail Amount</b>
				Bus 55 Repairs	40 E 2554 3230 00 300 000000		100.0000%	3,516.78
<b>Total for CIT Trucks:</b>							<b>3,516.78</b>	
CollegeBoard	1082400005	EA209789	DFC	Product Name: CollegeBoard Pre-AP English 1 SKU 190079172 Reference #00009521	08/02/2023	089063	6,000.00	
				<b>Detail Description</b>	<b>Detail Account</b>		<b>Accounting Percent</b>	<b>Detail Amount</b>
				Product Name: CollegeBoard Pre-AP English 1 SKU 190079172 Reference #00009521	10 E 2210 3000 00 300 000006		100.0000%	3,000.00
				Product Name: CollegeBoard Pre-AP English 2 SKU 190079173 Reference #00009521	10 E 2210 3000 00 300 000006		100.0000%	3,000.00
<b>Total for CollegeBoard:</b>							<b>6,000.00</b>	
Comcast		8771200230111706 3/24	DFC	Services 3/29-4/28	03/22/2024	089064	104.90	
				<b>Detail Description</b>	<b>Detail Account</b>		<b>Accounting Percent</b>	<b>Detail Amount</b>
				Services 3/29-4/28	10 E 2225 3000 00 300 000001		100.0000%	104.90
<b>Total for Comcast:</b>							<b>104.90</b>	
Comcast Business		198619290	DFC	April Services	04/01/2024	089065	5,044.80	
				<b>Detail Description</b>	<b>Detail Account</b>		<b>Accounting Percent</b>	<b>Detail Amount</b>
				April Services	10 E 2225 3000 00 300 000001		100.0000%	5,044.80
<b>Total for Comcast Business:</b>							<b>5,044.80</b>	
ComEd		1552430100 3/24	DFC	Services 2/20-3/19	03/19/2024	089066	551.52	
				<b>Detail Description</b>	<b>Detail Account</b>		<b>Accounting Percent</b>	<b>Detail Amount</b>
				Services 2/20-3/19	20 E 2540 4660 00 303 000000		100.0000%	551.52
<b>Total for ComEd:</b>							<b>551.52</b>	
Compass Health Center Oakbrook PLLC		859167	DFC	Homebound Tutoring	03/18/2024	089067	840.00	
				<b>Detail Description</b>	<b>Detail Account</b>		<b>Accounting Percent</b>	<b>Detail Amount</b>
				Homebound Tutoring	10 E 1200 6700 00 300 000002		100.0000%	840.00
<b>Total for Compass Health Center Oakbrook PLLC:</b>							<b>840.00</b>	

## Invoice Listing

COUNTY OF GRUNDY SCHOOL DIST 111

Vendor	PO Number	Invoice Number	Batch	Description	Invoice Date	Check Number	Net Amount
Constellation Energy Gas		3993129	DFC	February Services	03/21/2024	089068	8,586.70
		<b>Detail Description</b>	<b>Detail Account</b>		<b>Accounting Percent</b>		<b>Detail Amount</b>
		February Services	20 E 2540 4650 00 302 000000		40.2405%		3,455.33
		February Services	20 E 2540 4650 00 300 000000		59.7595%		5,131.37
		<b>Total for Constellation Energy Gas:</b>					<b>8,586.70</b>
Constellation New Energy		67723686702	DFC	Services 1/16-2/20	03/19/2024	089069	58.85
		<b>Detail Description</b>	<b>Detail Account</b>		<b>Accounting Percent</b>		<b>Detail Amount</b>
		Services 1/16-2/20	20 E 2540 3400 00 301 000000		100.0000%		58.85
Constellation New Energy		67736877702	DFC	Services 1/17-2/21	03/19/2024	089069	6,370.22
		<b>Detail Description</b>	<b>Detail Account</b>		<b>Accounting Percent</b>		<b>Detail Amount</b>
		Services 1/17-2/21	20 E 2540 4660 00 302 000000		100.0000%		6,370.22
Constellation New Energy		67940309301	DFC	Services 2/20-3/19	03/20/2024	089069	147.61
		<b>Detail Description</b>	<b>Detail Account</b>		<b>Accounting Percent</b>		<b>Detail Amount</b>
		Services 2/20-3/19	20 E 2540 3400 00 301 000000		100.0000%		147.61
Constellation New Energy		67966857901	DFC	Services 2/5-3/11	03/22/2024	089069	28,671.36
		<b>Detail Description</b>	<b>Detail Account</b>		<b>Accounting Percent</b>		<b>Detail Amount</b>
		Services 2/5-3/11	20 E 2540 4660 00 300 000000		100.0000%		28,671.36
		<b>Total for Constellation New Energy:</b>					<b>35,248.04</b>
Core Academy - Special Education Services		SESINV-036192	DFC	Tuition	03/22/2024	089070	2,545.27
		<b>Detail Description</b>	<b>Detail Account</b>		<b>Accounting Percent</b>		<b>Detail Amount</b>
		Tuition	10 E 1912 6700 00 300 000000		100.0000%		2,545.27
		<b>Total for Core Academy - Special Education Services:</b>					<b>2,545.27</b>
Creative Promotional Apparel Inc		18843	DFC	Promotions	04/02/2024	23596	1,258.00
		<b>Detail Description</b>	<b>Detail Account</b>		<b>Accounting Percent</b>		<b>Detail Amount</b>
		Promotions	11 E 1999 4100 70 300 900048		100.0000%		1,258.00
		<b>Total for Creative Promotional Apparel Inc:</b>					<b>1,258.00</b>

## Invoice Listing

COUNTY OF GRUNDY SCHOOL DIST 111

Vendor	PO Number	Invoice Number	Batch	Description	Invoice Date	Check Number	Net Amount
Cutting Edge Document Destruction		87259	DFC	Shredding	04/02/2024	9100002316	66.00
<b>Detail Description</b>		<b>Detail Account</b>		<b>Accounting Percent</b>		<b>Detail Amount</b>	
Shredding		10 E 2525 3000 00 300 000000		100.0000%		66.00	
<b>Total for Cutting Edge Document Destruction:</b>							<b>66.00</b>
Danielson, Sarah L		JV Socks Reimb	DFC	JV Socks Reimbursement	04/03/2024	23597	66.95
<b>Detail Description</b>		<b>Detail Account</b>		<b>Accounting Percent</b>		<b>Detail Amount</b>	
JV Socks		11 E 1999 4100 70 300 900051		100.0000%		66.95	
<b>Total for Danielson, Sarah L:</b>							<b>66.95</b>
Danielson, Scott		Bolt reimbursement	DFC	Bolt Reimbursement	04/03/2024	23598	49.64
<b>Detail Description</b>		<b>Detail Account</b>		<b>Accounting Percent</b>		<b>Detail Amount</b>	
Bolts for Prop Wheels		11 E 1999 4100 70 300 900051		100.0000%		49.64	
<b>Total for Danielson, Scott:</b>							<b>49.64</b>
Data-Based Consulting- DBC	1052400039	24101	DFC	Professional Development- Molly Highbaugh Section 504 Student Issues: A Basic Refresher-Focuses on the building blocks of an effective school program for students who are covered "only" by Section 504 and its sister statute, the Americans with Disabilities Act (ADA). "Only" in this context means that these students are not also covered by IDEA.	03/22/2024	089071	99.00
<b>Detail Description</b>		<b>Detail Account</b>		<b>Accounting Percent</b>		<b>Detail Amount</b>	
Professional Development- Molly Highbaugh Section 504 Student Issues: A Basic Refresher-Focuses on the building blocks of an effective school program for students who are covered "only" by Section 504 and its sister statute, the Americans with Disabilities Act (ADA). "Only" in this context means that these students are not also covered by IDEA.		10 E 2210 3000 00 300 000002		100.0000%		99.00	
<b>Total for Data-Based Consulting-DBC:</b>							<b>99.00</b>
DLA Ltd		240317	DFC	District Admin Building	03/31/2024	089072	13,098.59
<b>Detail Description</b>		<b>Detail Account</b>		<b>Accounting Percent</b>		<b>Detail Amount</b>	
District Admin Office		60 E 2533 3000 00 000 000000		100.0000%		13,098.59	

## Invoice Listing

COUNTY OF GRUNDY SCHOOL DIST 111

Vendor	PO Number	Invoice Number	Batch	Description	Invoice Date	Check Number	Net Amount
DLA Ltd		240336	DFC	District Mater Planning	03/31/2024	089072	1,462.82
<b>Detail Description</b>				<b>Detail Account</b>		<b>Accounting Percent</b>	<b>Detail Amount</b>
District Master Planning				60 E 2533 3000 00 000 000000		100.0000%	1,462.82
<b>Total for DLA Ltd:</b>							<b>14,561.41</b>
Ebsco	1172400035	1000227154-1	DFC	Flipster digital magazine renewal	03/17/2024	089073	976.83
<b>Detail Description</b>				<b>Detail Account</b>		<b>Accounting Percent</b>	<b>Detail Amount</b>
Flipster digital magazine renewal				10 E 2222 4400 00 300 000000		100.0000%	976.83
<b>Total for Ebsco:</b>							<b>976.83</b>
eMATHinstruction, Inc.	1112400030	10969	DFC	Supplemental materials for alg 1, geo, and alg 2. Looking to use for summer school and possibly next year.	04/05/2024	9100002317	150.00
<b>Detail Description</b>				<b>Detail Account</b>		<b>Accounting Percent</b>	<b>Detail Amount</b>
Common Core ALgebra 2 Membership				10 E 1130 4100 11 300 000000		100.0000%	150.00
<b>Total for eMATHinstruction, Inc.:</b>							<b>150.00</b>
ESI		1362583	DFC	Ice Machine Repairs & Maintenance	03/15/2024	9100002318	625.25
<b>Detail Description</b>				<b>Detail Account</b>		<b>Accounting Percent</b>	<b>Detail Amount</b>
Ice Machine Repair & Maintenance				20 E 2540 3230 00 302 000000		100.0000%	625.25
<b>Total for ESI:</b>							<b>625.25</b>
Feece Oil Company		2199743	DFC	Van 27 Fuel	03/06/2024	089074	42.21
<b>Detail Description</b>				<b>Detail Account</b>		<b>Accounting Percent</b>	<b>Detail Amount</b>
Van 27 Fuel				40 E 2550 4640 00 300 000000		100.0000%	42.21
Feece Oil Company		2199746	DFC	Bus 40 Fuel	03/06/2024	089074	81.88
<b>Detail Description</b>				<b>Detail Account</b>		<b>Accounting Percent</b>	<b>Detail Amount</b>
Bus 40 Fuel				40 E 2552 4640 00 300 000000		100.0000%	81.88
Feece Oil Company		2200643	DFC	Bus 72 Fuel	03/12/2024	089074	48.89
<b>Detail Description</b>				<b>Detail Account</b>		<b>Accounting Percent</b>	<b>Detail Amount</b>
Bus 72 Fuel				40 E 2552 4640 00 300 000000		100.0000%	48.89
Feece Oil Company		2200676	DFC	Bus 48 Fuel	03/13/2024	089074	57.81
<b>Detail Description</b>				<b>Detail Account</b>		<b>Accounting Percent</b>	<b>Detail Amount</b>
Bus 48 Fuel				40 E 2552 4640 00 300 000000		100.0000%	57.81
Feece Oil Company		2200710	DFC	Van 36 Fuel	03/13/2024	089074	42.51
<b>Detail Description</b>				<b>Detail Account</b>		<b>Accounting Percent</b>	<b>Detail Amount</b>
Van 36 Fuel				40 E 2550 4640 00 300 000000		100.0000%	42.51

## Invoice Listing

COUNTY OF GRUNDY SCHOOL DIST 111

Vendor	PO Number	Invoice Number	Batch	Description	Invoice Date	Check Number	Net Amount
Feece Oil Company		2200714	DFC	Bus 61 Fuel	03/13/2024	089074	73.28
<b>Detail Description</b>		<b>Detail Account</b>		<b>Accounting Percent</b>		<b>Detail Amount</b>	
				Bus 61 Fuel			73.28
				40 E 2552 4640 00 300 000000			100.0000%
Feece Oil Company		2200771	DFC	Van 27 Fuel	03/13/2024	089074	29.03
<b>Detail Description</b>		<b>Detail Account</b>		<b>Accounting Percent</b>		<b>Detail Amount</b>	
				Van 27 Fuel			29.03
				40 E 2550 4640 00 300 000000			100.0000%
Feece Oil Company		2200810	DFC	Bus 40 Fuel	03/13/2024	089074	78.62
<b>Detail Description</b>		<b>Detail Account</b>		<b>Accounting Percent</b>		<b>Detail Amount</b>	
				Bus 40 Fuel			78.62
				40 E 2552 4640 00 300 000000			100.0000%
Feece Oil Company		2200832	DFC	Bus 72 Fuel	03/13/2024	089074	47.11
<b>Detail Description</b>		<b>Detail Account</b>		<b>Accounting Percent</b>		<b>Detail Amount</b>	
				Bus 72 Fuel			47.11
				40 E 2552 4640 00 300 000000			100.0000%
Feece Oil Company		2200874	DFC	Bus 48 Fuel	03/14/2024	089074	56.62
<b>Detail Description</b>		<b>Detail Account</b>		<b>Accounting Percent</b>		<b>Detail Amount</b>	
				Bus 48 Fuel			56.62
				40 E 2552 4640 00 300 000000			100.0000%
Feece Oil Company		2200886	DFC	Bus 132 Fuel	03/14/2024	089074	66.40
<b>Detail Description</b>		<b>Detail Account</b>		<b>Accounting Percent</b>		<b>Detail Amount</b>	
				Bus 132 Fuel			66.40
				40 E 2552 4640 00 300 000000			100.0000%
Feece Oil Company		2200899	DFC	Bus 56 Fuel	03/14/2024	089074	53.90
<b>Detail Description</b>		<b>Detail Account</b>		<b>Accounting Percent</b>		<b>Detail Amount</b>	
				Bus 56 Fuel			53.90
				40 E 2552 4640 00 300 000000			100.0000%
Feece Oil Company		2200903	DFC	Bus 57 Fuel	03/14/2024	089074	24.60
<b>Detail Description</b>		<b>Detail Account</b>		<b>Accounting Percent</b>		<b>Detail Amount</b>	
				Bus 57 Fuel			24.60
				40 E 2552 4640 00 300 000000			100.0000%
Feece Oil Company		2200927	DFC	Maintenance Truck Fuel	03/14/2024	089074	127.26
<b>Detail Description</b>		<b>Detail Account</b>		<b>Accounting Percent</b>		<b>Detail Amount</b>	
				Maintenance Truck Fuel			127.26
				40 E 2550 4640 00 300 000000			100.0000%
Feece Oil Company		2200942	DFC	Car 5 Fuel	03/14/2024	089074	22.27
<b>Detail Description</b>		<b>Detail Account</b>		<b>Accounting Percent</b>		<b>Detail Amount</b>	
				Car 5 Fuel			22.27
				10 E 1700 4640 21 300 000000			100.0000%
Feece Oil Company		2200945	DFC	Van 27 Fuel	03/14/2024	089074	29.81
<b>Detail Description</b>		<b>Detail Account</b>		<b>Accounting Percent</b>		<b>Detail Amount</b>	
				Van 27 Fuel			29.81
				40 E 2550 4640 00 300 000000			100.0000%

## Invoice Listing

COUNTY OF GRUNDY SCHOOL DIST 111

Vendor	PO Number	Invoice Number	Batch	Description	Invoice Date	Check Number	Net Amount
Feece Oil Company		2200969	DFC	Van 8 Fuel	03/14/2024	089074	44.02
<b>Detail Description</b>		<b>Detail Account</b>		<b>Accounting Percent</b>		<b>Detail Amount</b>	
Van 8 Fuel		40 E 2550 4640 00 300 000000		100.0000%		44.02	
Feece Oil Company		2201005	DFC	Bus 72 Fuel	03/14/2024	089074	43.69
<b>Detail Description</b>		<b>Detail Account</b>		<b>Accounting Percent</b>		<b>Detail Amount</b>	
Bus 72 Fuel		40 E 2552 4640 00 300 000000		100.0000%		43.69	
Feece Oil Company		2201042	DFC	Bus 48 Fuel	03/15/2024	089074	55.85
<b>Detail Description</b>		<b>Detail Account</b>		<b>Accounting Percent</b>		<b>Detail Amount</b>	
Bus 48 Fuel		40 E 2552 4640 00 300 000000		100.0000%		55.85	
Feece Oil Company		2201075	DFC	Bus 56 Fuel	03/15/2024	089074	37.65
<b>Detail Description</b>		<b>Detail Account</b>		<b>Accounting Percent</b>		<b>Detail Amount</b>	
Bus 56 Fuel		40 E 2552 4640 00 300 000000		100.0000%		37.65	
Feece Oil Company		2201078	DFC	Bus 57 Fuel	03/15/2024	089074	53.34
<b>Detail Description</b>		<b>Detail Account</b>		<b>Accounting Percent</b>		<b>Detail Amount</b>	
Bus 57 Fuel		40 E 2552 4640 00 300 000000		100.0000%		53.34	
Feece Oil Company		2201094	DFC	Bus 61 Fuel	03/15/2024	089074	70.24
<b>Detail Description</b>		<b>Detail Account</b>		<b>Accounting Percent</b>		<b>Detail Amount</b>	
Bus 61 Fuel		40 E 2552 4640 00 300 000000		100.0000%		70.24	
Feece Oil Company		2201102	DFC	Van 27 Fuel	03/15/2024	089074	26.96
<b>Detail Description</b>		<b>Detail Account</b>		<b>Accounting Percent</b>		<b>Detail Amount</b>	
Van 27 Fuel		40 E 2550 4640 00 300 000000		100.0000%		26.96	
Feece Oil Company		2201155	DFC	Van 27 Fuel	03/15/2024	089074	35.33
<b>Detail Description</b>		<b>Detail Account</b>		<b>Accounting Percent</b>		<b>Detail Amount</b>	
Van 27 Fuel		40 E 2550 4640 00 300 000000		100.0000%		35.33	
Feece Oil Company		2201159	DFC	Bus 40 Fuel	03/15/2024	089074	59.65
<b>Detail Description</b>		<b>Detail Account</b>		<b>Accounting Percent</b>		<b>Detail Amount</b>	
Bus 40 Fuel		40 E 2552 4640 00 300 000000		100.0000%		59.65	
Feece Oil Company		2201200	DFC	Maintenance Truck Fuel	03/15/2024	089074	47.15
<b>Detail Description</b>		<b>Detail Account</b>		<b>Accounting Percent</b>		<b>Detail Amount</b>	
Maintenance Truck Fuel		40 E 2550 4640 00 300 000000		100.0000%		47.15	
Feece Oil Company		2201254	DFC	Bus 48 Fuel	03/18/2024	089074	54.99
<b>Detail Description</b>		<b>Detail Account</b>		<b>Accounting Percent</b>		<b>Detail Amount</b>	
Bus 48 Fuel		40 E 2552 4640 00 300 000000		100.0000%		54.99	

## Invoice Listing

COUNTY OF GRUNDY SCHOOL DIST 111

Vendor	PO Number	Invoice Number	Batch	Description	Invoice Date	Check Number	Net Amount
Feece Oil Company		2201255	DFC	Bus 84 Fuel	03/18/2024	089074	33.53
<b>Detail Description</b>		<b>Detail Account</b>		<b>Accounting Percent</b>		<b>Detail Amount</b>	
				Bus 84 Fuel			33.53
				40 E 2552 4640 00 300 000000			100.0000%
Feece Oil Company		2201295	DFC	Van 35 Fuel	03/18/2024	089074	66.28
<b>Detail Description</b>		<b>Detail Account</b>		<b>Accounting Percent</b>		<b>Detail Amount</b>	
				Van 35 Fuel			66.28
				40 E 2550 4640 00 300 000000			100.0000%
Feece Oil Company		2201302	DFC	Bus 56 Fuel	03/18/2024	089074	30.47
<b>Detail Description</b>		<b>Detail Account</b>		<b>Accounting Percent</b>		<b>Detail Amount</b>	
				Bus 56 Fuel			30.47
				40 E 2552 4640 00 300 000000			100.0000%
Feece Oil Company		2201305	DFC	Bus 57 Fuel	03/18/2024	089074	57.14
<b>Detail Description</b>		<b>Detail Account</b>		<b>Accounting Percent</b>		<b>Detail Amount</b>	
				Bus 57 Fuel			57.14
				40 E 2552 4640 00 300 000000			100.0000%
Feece Oil Company		2201339	DFC	Car 8 Fuel	03/18/2024	089074	28.37
<b>Detail Description</b>		<b>Detail Account</b>		<b>Accounting Percent</b>		<b>Detail Amount</b>	
				Car 8 Fuel			28.37
				10 E 1700 4640 21 300 000000			100.0000%
Feece Oil Company		2201354	DFC	Car 6 Fuel	03/18/2024	089074	26.37
<b>Detail Description</b>		<b>Detail Account</b>		<b>Accounting Percent</b>		<b>Detail Amount</b>	
				Car 6 Fuel			26.37
				10 E 1700 4640 21 300 000000			100.0000%
Feece Oil Company		2201375	DFC	Van 8 Fuel	03/18/2024	089074	41.40
<b>Detail Description</b>		<b>Detail Account</b>		<b>Accounting Percent</b>		<b>Detail Amount</b>	
				Van 8 Fuel			41.40
				40 E 2550 4640 00 300 000000			100.0000%
Feece Oil Company		2201409	DFC	Van 36 Fuel	03/18/2024	089074	26.07
<b>Detail Description</b>		<b>Detail Account</b>		<b>Accounting Percent</b>		<b>Detail Amount</b>	
				Van 36 Fuel			26.07
				40 E 2550 4640 00 300 000000			100.0000%
Feece Oil Company		2201419	DFC	Van 27 Fuel	03/18/2024	089074	43.59
<b>Detail Description</b>		<b>Detail Account</b>		<b>Accounting Percent</b>		<b>Detail Amount</b>	
				Van 27 Fuel			43.59
				40 E 2550 4640 00 300 000000			100.0000%
Feece Oil Company		2201424	DFC	Bus 72 Fuel	03/18/2024	089074	51.18
<b>Detail Description</b>		<b>Detail Account</b>		<b>Accounting Percent</b>		<b>Detail Amount</b>	
				Bus 72 Fuel			51.18
				40 E 2552 4640 00 300 000000			100.0000%
Feece Oil Company		2201452	DFC	Car 6 Fuel	03/18/2024	089074	-26.37
<b>Detail Description</b>		<b>Detail Account</b>		<b>Accounting Percent</b>		<b>Detail Amount</b>	
				Car 6 Fuel			-26.37
				10 E 1700 4640 21 300 000000			100.0000%

## Invoice Listing

COUNTY OF GRUNDY SCHOOL DIST 111

Vendor	PO Number	Invoice Number	Batch	Description	Invoice Date	Check Number	Net Amount
Feece Oil Company		2201453	DFC	Car 6 Fuel	03/18/2024	089074	28.77
<b>Detail Description</b>			<b>Detail Account</b>		<b>Accounting Percent</b>		<b>Detail Amount</b>
				Car 6 Fuel			28.77
				10 E 1700 4640 21 300 000000		100.0000%	28.77
Feece Oil Company		2201459	DFC	Bus 48 Fuel	03/19/2024	089074	64.68
<b>Detail Description</b>			<b>Detail Account</b>		<b>Accounting Percent</b>		<b>Detail Amount</b>
				Bus 48 Fuel			64.68
				40 E 2552 4640 00 300 000000		100.0000%	64.68
Feece Oil Company		2201498	DFC	Bus 57 Fuel	03/19/2024	089074	62.77
<b>Detail Description</b>			<b>Detail Account</b>		<b>Accounting Percent</b>		<b>Detail Amount</b>
				Bus 57 Fuel			62.77
				40 E 2552 4640 00 300 000000		100.0000%	62.77
Feece Oil Company		2201502	DFC	Bus 61 Fuel	03/19/2024	089074	76.59
<b>Detail Description</b>			<b>Detail Account</b>		<b>Accounting Percent</b>		<b>Detail Amount</b>
				Bus 61 Fuel			76.59
				40 E 2552 4640 00 300 000000		100.0000%	76.59
Feece Oil Company		2201542	DFC	Van 37 Fuel	03/19/2024	089074	42.03
<b>Detail Description</b>			<b>Detail Account</b>		<b>Accounting Percent</b>		<b>Detail Amount</b>
				Van 37 Fuel			42.03
				40 E 2550 4640 00 300 000000		100.0000%	42.03
Feece Oil Company		2201566	DFC	Activity Bus 1	03/19/2024	089074	75.82
<b>Detail Description</b>			<b>Detail Account</b>		<b>Accounting Percent</b>		<b>Detail Amount</b>
				Activity Bus 1 Fuel (Baseball)			75.82
				10 E 1500 3900 30 300 000000		100.0000%	75.82
Feece Oil Company		2201576	DFC	Car 3 Fuel	03/19/2024	089074	41.08
<b>Detail Description</b>			<b>Detail Account</b>		<b>Accounting Percent</b>		<b>Detail Amount</b>
				Car 3 Fuel			41.08
				10 E 1700 4640 21 300 000000		100.0000%	41.08
Feece Oil Company		2201578	DFC	Activity Bus 2	03/19/2024	089074	57.86
<b>Detail Description</b>			<b>Detail Account</b>		<b>Accounting Percent</b>		<b>Detail Amount</b>
				Activity Bus 2 (Baseball)			57.86
				10 E 1500 3900 30 300 000000		100.0000%	57.86
Feece Oil Company		2201590	DFC	Bus 76 Fuel	03/19/2024	089074	68.87
<b>Detail Description</b>			<b>Detail Account</b>		<b>Accounting Percent</b>		<b>Detail Amount</b>
				Bus 76 Fuel			68.87
				40 E 2552 4640 00 300 000000		100.0000%	68.87
Feece Oil Company		2201611	DFC	Car 9 Fuel	03/19/2024	089074	36.55
<b>Detail Description</b>			<b>Detail Account</b>		<b>Accounting Percent</b>		<b>Detail Amount</b>
				Car 9 Fuel			36.55
				10 E 1700 4640 21 300 000000		100.0000%	36.55
Feece Oil Company		2201645	DFC	Bus 40 Fuel	03/19/2024	089074	74.05
<b>Detail Description</b>			<b>Detail Account</b>		<b>Accounting Percent</b>		<b>Detail Amount</b>
				Bus 40 Fuel			74.05
				40 E 2552 4640 00 300 000000		100.0000%	74.05

## Invoice Listing

COUNTY OF GRUNDY SCHOOL DIST 111

Vendor	PO Number	Invoice Number	Batch	Description	Invoice Date	Check Number	Net Amount
Feece Oil Company		2201648	DFC	Bus 72 Fuel	03/19/2024	089074	51.98
<b>Detail Description</b>		<b>Detail Account</b>		<b>Accounting Percent</b>		<b>Detail Amount</b>	
Bus 72 Fuel		40 E 2552 4640 00 300 000000		100.0000%		51.98	
Feece Oil Company		2201683	DFC	Bus 48 Fuel	03/20/2024	089074	64.10
<b>Detail Description</b>		<b>Detail Account</b>		<b>Accounting Percent</b>		<b>Detail Amount</b>	
Bus 48 Fuel		40 E 2552 4640 00 300 000000		100.0000%		64.10	
Feece Oil Company		2201723	DFC	Bus 56	03/20/2024	089074	50.01
<b>Detail Description</b>		<b>Detail Account</b>		<b>Accounting Percent</b>		<b>Detail Amount</b>	
Bus 56 Fuel		40 E 2552 4640 00 300 000000		100.0000%		50.01	
Feece Oil Company		2201725	DFC	Bus 57 Fuel	03/20/2024	089074	59.55
<b>Detail Description</b>		<b>Detail Account</b>		<b>Accounting Percent</b>		<b>Detail Amount</b>	
Bus 57 Fuel		40 E 2552 4640 00 300 000000		100.0000%		59.55	
Feece Oil Company		2201726	DFC	Car 5 Fuel	03/20/2024	089074	24.39
<b>Detail Description</b>		<b>Detail Account</b>		<b>Accounting Percent</b>		<b>Detail Amount</b>	
Car 5 Fuel		10 E 1700 4640 21 300 000000		100.0000%		24.39	
Feece Oil Company		2201867	DFC	Car 7 Fuel	03/20/2024	089074	29.44
<b>Detail Description</b>		<b>Detail Account</b>		<b>Accounting Percent</b>		<b>Detail Amount</b>	
Car 7 Fuel		10 E 1700 4640 21 300 000000		100.0000%		29.44	
Feece Oil Company		2201869	DFC	Maintenance Truck Fuel	03/20/2024	089074	134.45
<b>Detail Description</b>		<b>Detail Account</b>		<b>Accounting Percent</b>		<b>Detail Amount</b>	
Maintenance Truck Fuel		40 E 2550 4640 00 300 000000		100.0000%		134.45	
Feece Oil Company		2201871	DFC	Van 36 Fuel	03/20/2024	089074	29.99
<b>Detail Description</b>		<b>Detail Account</b>		<b>Accounting Percent</b>		<b>Detail Amount</b>	
Van 36 Fuel		40 E 2550 4640 00 300 000000		100.0000%		29.99	
Feece Oil Company		2201884	DFC	Van 8 Fuel	03/20/2024	089074	53.79
<b>Detail Description</b>		<b>Detail Account</b>		<b>Accounting Percent</b>		<b>Detail Amount</b>	
Van 8 Fuel		40 E 2550 4640 00 300 000000		100.0000%		53.79	
Feece Oil Company		2201910	DFC	Bus 61 Fuel	03/20/2024	089074	61.74
<b>Detail Description</b>		<b>Detail Account</b>		<b>Accounting Percent</b>		<b>Detail Amount</b>	
Bus 61 Fuel		40 E 2552 4640 00 300 000000		100.0000%		61.74	
Feece Oil Company		2201916	DFC	Maintenance Truck Fuel	03/20/2024	089074	53.24
<b>Detail Description</b>		<b>Detail Account</b>		<b>Accounting Percent</b>		<b>Detail Amount</b>	
Maintenance Truck Fuel		40 E 2550 4640 00 300 000000		100.0000%		53.24	

## Invoice Listing

COUNTY OF GRUNDY SCHOOL DIST 111

Vendor	PO Number	Invoice Number	Batch	Description	Invoice Date	Check Number	Net Amount
Feece Oil Company		2201918	DFC	Van 27 Fuel	03/20/2024	089074	31.85
<b>Detail Description</b>		<b>Detail Account</b>		<b>Accounting Percent</b>		<b>Detail Amount</b>	
Van 27 Fuel		40 E 2550 4640 00 300 000000		100.0000%		31.85	
Feece Oil Company		2201953	DFC	Bus 48 Fuel	03/21/2024	089074	62.68
<b>Detail Description</b>		<b>Detail Account</b>		<b>Accounting Percent</b>		<b>Detail Amount</b>	
Bus 48 Fuel		40 E 2552 4640 00 300 000000		100.0000%		62.68	
Feece Oil Company		2201972	DFC	Van 35 Fuel	03/21/2024	089074	72.96
<b>Detail Description</b>		<b>Detail Account</b>		<b>Accounting Percent</b>		<b>Detail Amount</b>	
Van 35 Fuel		40 E 2550 4640 00 300 000000		100.0000%		72.96	
Feece Oil Company		2201975	DFC	Bus 56 Fuel	03/21/2024	089074	37.79
<b>Detail Description</b>		<b>Detail Account</b>		<b>Accounting Percent</b>		<b>Detail Amount</b>	
Bus 56 Fuel		40 E 2552 4640 00 300 000000		100.0000%		37.79	
Feece Oil Company		2201977	DFC	Bus 57 Fuel	03/21/2024	089074	60.84
<b>Detail Description</b>		<b>Detail Account</b>		<b>Accounting Percent</b>		<b>Detail Amount</b>	
Bus 57 Fuel		40 E 2552 4640 00 300 000000		100.0000%		60.84	
Feece Oil Company		2201982	DFC	Maintenance Truck Fuel	03/21/2024	089074	143.04
<b>Detail Description</b>		<b>Detail Account</b>		<b>Accounting Percent</b>		<b>Detail Amount</b>	
Maintenance Truck Fuel		40 E 2550 4640 00 300 000000		100.0000%		143.04	
Feece Oil Company		2201994	DFC	Bus 40 Fuel	03/21/2024	089074	71.67
<b>Detail Description</b>		<b>Detail Account</b>		<b>Accounting Percent</b>		<b>Detail Amount</b>	
Bus 40 Fuel		40 E 2552 4640 00 300 000000		100.0000%		71.67	
Feece Oil Company		2202071	DFC	Van 36 Fuel	03/21/2024	089074	33.21
<b>Detail Description</b>		<b>Detail Account</b>		<b>Accounting Percent</b>		<b>Detail Amount</b>	
Van 36 Fuel		40 E 2550 4640 00 300 000000		100.0000%		33.21	
Feece Oil Company		2202113	DFC	Bus 72 Fuel	03/21/2024	089074	51.05
<b>Detail Description</b>		<b>Detail Account</b>		<b>Accounting Percent</b>		<b>Detail Amount</b>	
Bus 72 Fuel		40 E 2552 4640 00 300 000000		100.0000%		51.05	
Feece Oil Company		2202143	DFC	Bus 48 Fuel	03/22/2024	089074	63.15
<b>Detail Description</b>		<b>Detail Account</b>		<b>Accounting Percent</b>		<b>Detail Amount</b>	
Bus 48 Fuel		40 E 2552 4640 00 300 000000		100.0000%		63.15	
Feece Oil Company		2202159	DFC	Bus 56 Fuel	03/22/2024	089074	34.23
<b>Detail Description</b>		<b>Detail Account</b>		<b>Accounting Percent</b>		<b>Detail Amount</b>	
Bus 56 Fuel		40 E 2552 4640 00 300 000000		100.0000%		34.23	

## Invoice Listing

COUNTY OF GRUNDY SCHOOL DIST 111

Vendor	PO Number	Invoice Number	Batch	Description	Invoice Date	Check Number	Net Amount
Feece Oil Company		2202164	DFC	Bus 57 Fuel	03/22/2024	089074	60.90
<b>Detail Description</b>		<b>Detail Account</b>		<b>Accounting Percent</b>		<b>Detail Amount</b>	
				Bus 57 Fuel			60.90
				40 E 2552 4640 00 300 000000			100.0000%
Feece Oil Company		2202174	DFC	Bus 61 Fuel	03/22/2024	089074	56.46
<b>Detail Description</b>		<b>Detail Account</b>		<b>Accounting Percent</b>		<b>Detail Amount</b>	
				Bus 61 Fuel			56.46
				40 E 2552 4640 00 300 000000			100.0000%
Feece Oil Company		2202302	DFC	Bus 72 Fuel	03/22/2024	089074	51.09
<b>Detail Description</b>		<b>Detail Account</b>		<b>Accounting Percent</b>		<b>Detail Amount</b>	
				Bus 72 Fuel			51.09
				40 E 2552 4640 00 300 000000			100.0000%
Feece Oil Company		2203921	DFC	Bus 72 Fuel	03/25/2024	089074	51.10
<b>Detail Description</b>		<b>Detail Account</b>		<b>Accounting Percent</b>		<b>Detail Amount</b>	
				Bus 72 Fuel			51.10
				40 E 2552 4640 00 300 000000			100.0000%
Feece Oil Company		2204198	DFC	Maintenance Truck Fuel	03/26/2024	089074	55.45
<b>Detail Description</b>		<b>Detail Account</b>		<b>Accounting Percent</b>		<b>Detail Amount</b>	
				Maintenance Truck Fuel			55.45
				40 E 2550 4640 00 300 000000			100.0000%
Feece Oil Company		2204207	DFC	Maintenance Truck Fuel	03/26/2024	089074	105.92
<b>Detail Description</b>		<b>Detail Account</b>		<b>Accounting Percent</b>		<b>Detail Amount</b>	
				Maintenance Truck Fuel			105.92
				40 E 2550 4640 00 300 000000			100.0000%
Feece Oil Company		2204315	DFC	Bus 72 Fuel	03/26/2024	089074	53.71
<b>Detail Description</b>		<b>Detail Account</b>		<b>Accounting Percent</b>		<b>Detail Amount</b>	
				Bus 72 Fuel			53.71
				40 E 2552 4640 00 300 000000			100.0000%
Feece Oil Company		2204414	DFC	Activity Bus 1	03/27/2024	089074	46.73
<b>Detail Description</b>		<b>Detail Account</b>		<b>Accounting Percent</b>		<b>Detail Amount</b>	
				Activity Bus 1			46.73
				10 E 1500 3900 30 300 000000			100.0000%
Feece Oil Company		2204415	DFC	Activity Bus 2	03/27/2024	089074	50.46
<b>Detail Description</b>		<b>Detail Account</b>		<b>Accounting Percent</b>		<b>Detail Amount</b>	
				Activity Bus 2 Fuel (Boys Baseball)			50.46
				10 E 1500 3900 30 300 000000			100.0000%
Feece Oil Company		2204481	DFC	Bus 72 Fuel	03/27/2024	089074	51.86
<b>Detail Description</b>		<b>Detail Account</b>		<b>Accounting Percent</b>		<b>Detail Amount</b>	
				Bus 72 Fuel			51.86
				40 E 2552 4640 00 300 000000			100.0000%
Feece Oil Company		2204677	DFC	Bus 72 Fuel	03/28/2024	089074	53.32
<b>Detail Description</b>		<b>Detail Account</b>		<b>Accounting Percent</b>		<b>Detail Amount</b>	
				Bus 72 Fuel			53.32
				40 E 2552 4640 00 300 000000			100.0000%

## Invoice Listing

COUNTY OF GRUNDY SCHOOL DIST 111

Vendor	PO Number	Invoice Number	Batch	Description	Invoice Date	Check Number	Net Amount
Feece Oil Company		2205102	DFC	Bus 72 Fuel	03/29/2024	089074	47.99
<b>Detail Description</b>		<b>Detail Account</b>		<b>Accounting Percent</b>		<b>Detail Amount</b>	
				Bus 72 Fuel			47.99
				40 E 2552 4640 00 300 000000			100.0000%
Feece Oil Company		2205308	DFC	Bus 48 Fuel	04/01/2024	089074	61.59
<b>Detail Description</b>		<b>Detail Account</b>		<b>Accounting Percent</b>		<b>Detail Amount</b>	
				Bus 48 Fuel			61.59
				40 E 2552 4640 00 300 000000			100.0000%
Feece Oil Company		2205351	DFC	Van 27 Fuel	04/01/2024	089074	49.42
<b>Detail Description</b>		<b>Detail Account</b>		<b>Accounting Percent</b>		<b>Detail Amount</b>	
				Van 27 Fuel			49.42
				40 E 2550 4640 00 300 000000			100.0000%
Feece Oil Company		2205414	DFC	Activity Bus 4 Fuel	04/01/2024	089074	86.90
<b>Detail Description</b>		<b>Detail Account</b>		<b>Accounting Percent</b>		<b>Detail Amount</b>	
				Activity Bus 4 Fuel			86.90
				10 E 1500 3900 30 300 000000			100.0000%
Feece Oil Company		2205416	DFC	Activity Bus 3 Fuel	04/01/2024	089074	96.78
<b>Detail Description</b>		<b>Detail Account</b>		<b>Accounting Percent</b>		<b>Detail Amount</b>	
				Activity Bus 3 Fuel (Boys Baseball)			96.78
				10 E 1500 3900 30 300 000000			100.0000%
Feece Oil Company		2205470	DFC	Bus 48 Fuel	04/02/2024	089074	65.16
<b>Detail Description</b>		<b>Detail Account</b>		<b>Accounting Percent</b>		<b>Detail Amount</b>	
				Bus 48 Fuel			65.16
				40 E 2552 4640 00 300 000000			100.0000%
Feece Oil Company		2205488	DFC	Bus 57 Fuel	04/02/2024	089074	63.84
<b>Detail Description</b>		<b>Detail Account</b>		<b>Accounting Percent</b>		<b>Detail Amount</b>	
				Bus 57 Fuel			63.84
				40 E 2552 4640 00 300 000000			100.0000%
Feece Oil Company		2205512	DFC	Bus 61 Fuel	04/02/2024	089074	74.43
<b>Detail Description</b>		<b>Detail Account</b>		<b>Accounting Percent</b>		<b>Detail Amount</b>	
				Bus 61 Fuel			74.43
				40 E 2552 4640 00 300 000000			100.0000%
Feece Oil Company		2205516	DFC	Van 8 Fuel	04/02/2024	089074	46.84
<b>Detail Description</b>		<b>Detail Account</b>		<b>Accounting Percent</b>		<b>Detail Amount</b>	
				Van 8 Fuel			46.84
				40 E 2550 4640 00 300 000000			100.0000%
Feece Oil Company		2205635	DFC	Van 36 Fuel	04/02/2024	089074	39.76
<b>Detail Description</b>		<b>Detail Account</b>		<b>Accounting Percent</b>		<b>Detail Amount</b>	
				Van 36 Fuel			39.76
				40 E 2550 4640 00 300 000000			100.0000%
Feece Oil Company		2205646	DFC	Van 27 Fuel	04/02/2024	089074	37.94
<b>Detail Description</b>		<b>Detail Account</b>		<b>Accounting Percent</b>		<b>Detail Amount</b>	
				Van 27 Fuel			37.94
				40 E 2550 4640 00 300 000000			100.0000%

## Invoice Listing

COUNTY OF GRUNDY SCHOOL DIST 111

Vendor	PO Number	Invoice Number	Batch	Description	Invoice Date	Check Number	Net Amount
Feece Oil Company		2205683	DFC	Bus 48 Fuel	04/03/2024	089074	73.30
<b>Detail Description</b>		<b>Detail Account</b>		<b>Accounting Percent</b>		<b>Detail Amount</b>	
Bus 48 Fuel		40 E 2552 4640 00 300 000000		100.0000%		73.30	
Feece Oil Company		2205701	DFC	Bus Fuel	04/03/2024	089074	73.38
<b>Detail Description</b>		<b>Detail Account</b>		<b>Accounting Percent</b>		<b>Detail Amount</b>	
Bus Fuel		40 E 2552 4640 00 300 000000		100.0000%		73.38	
Feece Oil Company		2205735	DFC	Bus 56 Fuel	04/03/2024	089074	51.76
<b>Detail Description</b>		<b>Detail Account</b>		<b>Accounting Percent</b>		<b>Detail Amount</b>	
Bus 56 Fuel		40 E 2552 4640 00 300 000000		100.0000%		51.76	
Feece Oil Company		2205738	DFC	Bus 57 Fuel	04/03/2024	089074	66.31
<b>Detail Description</b>		<b>Detail Account</b>		<b>Accounting Percent</b>		<b>Detail Amount</b>	
Bus 57 Fuel		40 E 2552 4640 00 300 000000		100.0000%		66.31	
Feece Oil Company		2205754	DFC	Car 8 Fuel	04/03/2024	089074	32.18
<b>Detail Description</b>		<b>Detail Account</b>		<b>Accounting Percent</b>		<b>Detail Amount</b>	
CAR 8 Fuel		10 E 1700 4640 21 300 000000		100.0000%		32.18	
Feece Oil Company		2205803	DFC	Car 5 Fuel	04/03/2024	089074	25.50
<b>Detail Description</b>		<b>Detail Account</b>		<b>Accounting Percent</b>		<b>Detail Amount</b>	
Car 5 Fuel		10 E 1700 4640 21 300 000000		100.0000%		25.50	
Feece Oil Company		2205827	DFC	Van 27 Fuel	04/03/2024	089074	44.85
<b>Detail Description</b>		<b>Detail Account</b>		<b>Accounting Percent</b>		<b>Detail Amount</b>	
Van 27 Fuel		40 E 2550 4640 00 300 000000		100.0000%		44.85	
Feece Oil Company		2205834	DFC	Bus 61 Fuel	04/03/2024	089074	65.78
<b>Detail Description</b>		<b>Detail Account</b>		<b>Accounting Percent</b>		<b>Detail Amount</b>	
Bus 61 Fuel		40 E 2552 4640 00 300 000000		100.0000%		65.78	
Feece Oil Company		2205863	DFC	Bus 48 Fuel	04/04/2024	089074	64.34
<b>Detail Description</b>		<b>Detail Account</b>		<b>Accounting Percent</b>		<b>Detail Amount</b>	
Bus 48 Fuel		40 E 2552 4640 00 300 000000		100.0000%		64.34	
Feece Oil Company		2205889	DFC	Van 35 Fuel	04/04/2024	089074	71.75
<b>Detail Description</b>		<b>Detail Account</b>		<b>Accounting Percent</b>		<b>Detail Amount</b>	
Van 35 Fuel		40 E 2550 4640 00 300 000000		100.0000%		71.75	
Feece Oil Company		2205896	DFC	Bus 57 Fuel	04/04/2024	089074	61.59
<b>Detail Description</b>		<b>Detail Account</b>		<b>Accounting Percent</b>		<b>Detail Amount</b>	
Bus 57 Fuel		40 E 2552 4640 00 300 000000		100.0000%		61.59	

## Invoice Listing

COUNTY OF GRUNDY SCHOOL DIST 111

Vendor	PO Number	Invoice Number	Batch	Description	Invoice Date	Check Number	Net Amount
Feece Oil Company		2205909	DFC	Van 27 Fuel	04/04/2024	089074	38.00
<b>Detail Description</b>		<b>Detail Account</b>		<b>Accounting Percent</b>		<b>Detail Amount</b>	
Van 27 Fuel		40 E 2550 4640 00 300 000000		100.0000%		38.00	
Feece Oil Company		2205912	DFC	Bus 40 Fuel	04/04/2024	089074	71.65
<b>Detail Description</b>		<b>Detail Account</b>		<b>Accounting Percent</b>		<b>Detail Amount</b>	
Bus 40 Fuel		40 E 2552 4640 00 300 000000		100.0000%		71.65	
Feece Oil Company		2205995	DFC	Van 36 Fuel	04/04/2024	089074	39.06
<b>Detail Description</b>		<b>Detail Account</b>		<b>Accounting Percent</b>		<b>Detail Amount</b>	
Van 36 Fuel		40 E 2550 4640 00 300 000000		100.0000%		39.06	
Feece Oil Company		2206027	DFC	Bus 48 Fuel	04/05/2024	089074	57.63
<b>Detail Description</b>		<b>Detail Account</b>		<b>Accounting Percent</b>		<b>Detail Amount</b>	
Bus 48 Fuel		40 E 2552 4640 00 300 000000		100.0000%		57.63	
Feece Oil Company		2206050	DFC	Van 8 Fuel	04/05/2024	089074	45.36
<b>Detail Description</b>		<b>Detail Account</b>		<b>Accounting Percent</b>		<b>Detail Amount</b>	
Van 8 Fuel		40 E 2550 4640 00 300 000000		100.0000%		45.36	
Feece Oil Company		2206054	DFC	Bus 56 Fuel	04/05/2024	089074	55.06
<b>Detail Description</b>		<b>Detail Account</b>		<b>Accounting Percent</b>		<b>Detail Amount</b>	
Bus 56 Fuel		40 E 2552 4640 00 300 000000		100.0000%		55.06	
Feece Oil Company		2206057	DFC	Car 9 Fuel	04/05/2024	089074	25.54
<b>Detail Description</b>		<b>Detail Account</b>		<b>Accounting Percent</b>		<b>Detail Amount</b>	
Car 9 Fuel		10 E 1700 4640 21 300 000000		100.0000%		25.54	
Feece Oil Company		2206058	DFC	Bus 57 Fuel	04/05/2024	089074	61.01
<b>Detail Description</b>		<b>Detail Account</b>		<b>Accounting Percent</b>		<b>Detail Amount</b>	
Bus 57 Fuel		40 E 2552 4640 00 300 000000		100.0000%		61.01	
Feece Oil Company		2206085	DFC	Bus 61 Fuel	04/05/2024	089074	56.20
<b>Detail Description</b>		<b>Detail Account</b>		<b>Accounting Percent</b>		<b>Detail Amount</b>	
Bus 61 Fuel		40 E 2552 4640 00 300 000000		100.0000%		56.20	
Feece Oil Company		2206128	DFC	Van 37 Fuel	04/05/2024	089074	84.35
<b>Detail Description</b>		<b>Detail Account</b>		<b>Accounting Percent</b>		<b>Detail Amount</b>	
Van 37 Fuel		40 E 2550 4640 00 300 000000		100.0000%		84.35	
Feece Oil Company		2206136	DFC	Bus 40 Fuel	04/05/2024	089074	45.55
<b>Detail Description</b>		<b>Detail Account</b>		<b>Accounting Percent</b>		<b>Detail Amount</b>	
Bus 40 Fuel		40 E 2552 4640 00 300 000000		100.0000%		45.55	

## Invoice Listing

COUNTY OF GRUNDY SCHOOL DIST 111

Vendor	PO Number	Invoice Number	Batch	Description	Invoice Date	Check Number	Net Amount
Feece Oil Company		2206166	DFC	Van 27 Fuel	04/05/2024	089074	23.34
<b>Detail Description</b>		<b>Detail Account</b>		<b>Accounting Percent</b>		<b>Detail Amount</b>	
Van 27 Fuel		40 E 2550 4640 00 300 000000		100.0000%		23.34	
Feece Oil Company		2206254	DFC	Band Trailer Fuel	04/06/2024	089074	61.21
<b>Detail Description</b>		<b>Detail Account</b>		<b>Accounting Percent</b>		<b>Detail Amount</b>	
Band Trailer Fuel		10 E 1500 3320 70 300 000000		100.0000%		61.21	
Feece Oil Company		2206275	DFC	Bus 48 Fuel	04/08/2024	089074	65.63
<b>Detail Description</b>		<b>Detail Account</b>		<b>Accounting Percent</b>		<b>Detail Amount</b>	
Bus 48 Fuel		40 E 2552 4640 00 300 000000		100.0000%		65.63	
Feece Oil Company		2206310	DFC	Van 35 Fuel	04/08/2024	089074	48.99
<b>Detail Description</b>		<b>Detail Account</b>		<b>Accounting Percent</b>		<b>Detail Amount</b>	
Van 35 Fuel		40 E 2550 4640 00 300 000000		100.0000%		48.99	
Feece Oil Company		2206324	DFC	Bus 57 Fuel	04/08/2024	089074	58.36
<b>Detail Description</b>		<b>Detail Account</b>		<b>Accounting Percent</b>		<b>Detail Amount</b>	
Bus 57 Fuel		40 E 2552 4640 00 300 000000		100.0000%		58.36	
Feece Oil Company		2206334	DFC	Van 27 Fuel	04/08/2024	089074	51.05
<b>Detail Description</b>		<b>Detail Account</b>		<b>Accounting Percent</b>		<b>Detail Amount</b>	
Van 27 Fuel		40 E 2550 4640 00 300 000000		100.0000%		51.05	
Feece Oil Company		2206388	DFC	Activity Bus 1	04/08/2024	089074	74.91
<b>Detail Description</b>		<b>Detail Account</b>		<b>Accounting Percent</b>		<b>Detail Amount</b>	
Activity Bus 1 Fuel (Baseball)		10 E 1500 3900 30 300 000000		100.0000%		74.91	
Feece Oil Company		2206394	DFC	Activity Bus 2 Fuel	04/08/2024	089074	79.40
<b>Detail Description</b>		<b>Detail Account</b>		<b>Accounting Percent</b>		<b>Detail Amount</b>	
Activity Bus 2 Fuel (Baseball)		10 E 1500 3900 30 300 000000		100.0000%		79.40	
Feece Oil Company		2206404	DFC	Bus 76 Fuel	04/08/2024	089074	72.95
<b>Detail Description</b>		<b>Detail Account</b>		<b>Accounting Percent</b>		<b>Detail Amount</b>	
Bus 76 Fuel		40 E 2552 4640 00 300 000000		100.0000%		72.95	
Feece Oil Company		2206437	DFC	Bus 72 Fuel	04/08/2024	089074	50.56
<b>Detail Description</b>		<b>Detail Account</b>		<b>Accounting Percent</b>		<b>Detail Amount</b>	
Bus 72 Fuel		40 E 2552 4640 00 300 000000		100.0000%		50.56	
Feece Oil Company		2206481	DFC	Bus 48 Fuel	04/09/2024	089074	62.21
<b>Detail Description</b>		<b>Detail Account</b>		<b>Accounting Percent</b>		<b>Detail Amount</b>	
Bus 48 Fuel		40 E 2552 4640 00 300 000000		100.0000%		62.21	

## Invoice Listing

COUNTY OF GRUNDY SCHOOL DIST 111

Vendor	PO Number	Invoice Number	Batch	Description	Invoice Date	Check Number	Net Amount
Feece Oil Company		2206504	DFC	Bus 56 Fuel	04/09/2024	089074	56.27
<b>Detail Description</b>		<b>Detail Account</b>		<b>Accounting Percent</b>		<b>Detail Amount</b>	
				Bus 56 Fuel			56.27
				40 E 2552 4640 00 300 000000			100.0000%
Feece Oil Company		2206505	DFC	Bus 57 Fuel	04/09/2024	089074	58.55
<b>Detail Description</b>		<b>Detail Account</b>		<b>Accounting Percent</b>		<b>Detail Amount</b>	
				Bus 57 Fuel			58.55
				40 E 2552 4640 00 300 000000			100.0000%
Feece Oil Company		2206516	DFC	Car 7 Fuel	04/09/2024	089074	26.44
<b>Detail Description</b>		<b>Detail Account</b>		<b>Accounting Percent</b>		<b>Detail Amount</b>	
				Car 7 Fuel			26.44
				10 E 1700 4640 21 300 000000			100.0000%
Feece Oil Company		2206518	DFC	Bus 61 Fuel	04/09/2024	089074	76.96
<b>Detail Description</b>		<b>Detail Account</b>		<b>Accounting Percent</b>		<b>Detail Amount</b>	
				Bus 61 Fuel			76.96
				40 E 2552 4640 00 300 000000			100.0000%
Feece Oil Company		2206524	DFC	Bus 40 Fuel	04/09/2024	089074	86.14
<b>Detail Description</b>		<b>Detail Account</b>		<b>Accounting Percent</b>		<b>Detail Amount</b>	
				Bus 40 Fuel			86.14
				40 E 2552 4640 00 300 000000			100.0000%
Feece Oil Company		2206546	DFC	Maintenance Truck Fuel	04/09/2024	089074	111.46
<b>Detail Description</b>		<b>Detail Account</b>		<b>Accounting Percent</b>		<b>Detail Amount</b>	
				Maintenance Truck Fuel			111.46
				40 E 2550 4640 00 300 000000			100.0000%
Feece Oil Company		2206585	DFC	Van 8 Fuel	04/09/2024	089074	53.11
<b>Detail Description</b>		<b>Detail Account</b>		<b>Accounting Percent</b>		<b>Detail Amount</b>	
				Van 8 Fuel			53.11
				40 E 2550 4640 00 300 000000			100.0000%
Feece Oil Company		2206628	DFC	Bus 72 Fuel	04/09/2024	089074	50.09
<b>Detail Description</b>		<b>Detail Account</b>		<b>Accounting Percent</b>		<b>Detail Amount</b>	
				Bus 72 Fuel			50.09
				40 E 2552 4640 00 300 000000			100.0000%
Feece Oil Company		2206662	DFC	Bus 48 Fuel	04/10/2024	089074	78.86
<b>Detail Description</b>		<b>Detail Account</b>		<b>Accounting Percent</b>		<b>Detail Amount</b>	
				Bus 48 Fuel			78.86
				40 E 2552 4640 00 300 000000			100.0000%
Feece Oil Company		2206663	DFC	Van 35 Fuel	04/10/2024	089074	29.91
<b>Detail Description</b>		<b>Detail Account</b>		<b>Accounting Percent</b>		<b>Detail Amount</b>	
				Van 35 Fuel			29.91
				40 E 2550 4640 00 300 000000			100.0000%
Feece Oil Company		4057629	DFC	On Road Hi Speed Diesel	03/15/2024	089074	4,220.63
<b>Detail Description</b>		<b>Detail Account</b>		<b>Accounting Percent</b>		<b>Detail Amount</b>	
				On Road Hi Speed Diesel			4,220.63
				40 E 2552 4640 00 300 000000			100.0000%

## Invoice Listing

COUNTY OF GRUNDY SCHOOL DIST 111

Vendor	PO Number	Invoice Number	Batch	Description	Invoice Date	Check Number	Net Amount
Feece Oil Company		4057926	DFC	BlueDef Exhaust Fluid	03/11/2024	089074	402.50
<b>Detail Description</b>				<b>Detail Account</b>		<b>Accounting Percent</b>	<b>Detail Amount</b>
BlueDef Exhaust Fluid				40 E 2552 4640 00 300 000000		100.0000%	402.50
Feece Oil Company		4058604	DFC	On Road High Speed Diesel	03/11/2024	089074	4,211.60
<b>Detail Description</b>				<b>Detail Account</b>		<b>Accounting Percent</b>	<b>Detail Amount</b>
On Road Hi Speed Diesel				40 E 2552 4640 00 300 000000		100.0000%	4,211.60
Feece Oil Company		4061533	DFC	On Road Hi Speed Diesel	03/22/2024	089074	6,233.74
<b>Detail Description</b>				<b>Detail Account</b>		<b>Accounting Percent</b>	<b>Detail Amount</b>
On Road Hi Speed Diesel				40 E 2552 4640 00 300 000000		100.0000%	6,233.74
Feece Oil Company		4062699	DFC	On Road Hi Speed Diesel	04/05/2024	089074	4,100.82
<b>Detail Description</b>				<b>Detail Account</b>		<b>Accounting Percent</b>	<b>Detail Amount</b>
On Road HI Speed Diesel				40 E 2552 4640 00 300 000000		100.0000%	4,100.82
Feece Oil Company		4065242	DFC	BlueDef Exhaust Fluid	04/08/2024	089074	232.65
<b>Detail Description</b>				<b>Detail Account</b>		<b>Accounting Percent</b>	<b>Detail Amount</b>
BlueDef Exhaust Fluid				40 E 2552 4640 00 300 000000		100.0000%	232.65
<b>Total for Feece Oil Company:</b>							<b>26,889.46</b>
Filter Shine Chicago		12466150	DFC	8 Week Filter Rental - Galvaniz	03/22/2024	9100002319	100.00
<b>Detail Description</b>				<b>Detail Account</b>		<b>Accounting Percent</b>	<b>Detail Amount</b>
8 Week Filter Rental - Galvaniz				20 E 2540 3900 00 300 000000		100.0000%	100.00
Filter Shine Chicago		12466151	DFC	8 Week Filter Rental - Stainless Steel	03/22/2024	9100002319	185.00
<b>Detail Description</b>				<b>Detail Account</b>		<b>Accounting Percent</b>	<b>Detail Amount</b>
8 Week Filter Rental - Stainless Steel				20 E 2540 3900 00 300 000000		100.0000%	185.00
Filter Shine Chicago		12466152	DFC	8 Week Filter Rental - Stainless	03/22/2024	9100002319	185.00
<b>Detail Description</b>				<b>Detail Account</b>		<b>Accounting Percent</b>	<b>Detail Amount</b>
8 Week Filter Rental - Stainless				20 E 2540 3900 00 302 000000		100.0000%	185.00
<b>Total for Filter Shine Chicago:</b>							<b>470.00</b>
Flood's Royal Flush		I34442	DFC	Unit Rental	03/21/2024	089075	1,310.00
<b>Detail Description</b>				<b>Detail Account</b>		<b>Accounting Percent</b>	<b>Detail Amount</b>
Porta Potty Unit Rental				20 E 2540 4100 00 300 000001		100.0000%	1,310.00
<b>Total for Flood's Royal Flush:</b>							<b>1,310.00</b>

## Invoice Listing

COUNTY OF GRUNDY SCHOOL DIST 111

Vendor	PO Number	Invoice Number	Batch	Description	Invoice Date	Check Number	Net Amount
Follett School Solutions Inc	1172400046	369497	DFC	Books for Central Campus	04/03/2024	089076	180.39
<b>Detail Description</b>				<b>Detail Account</b>		<b>Accounting Percent</b>	<b>Detail Amount</b>
Books for Central Campus				10 E 2222 4300 00 300 000000		100.0000%	180.39
Follett School Solutions Inc	1172400049	369494	DFC	Books for South Campus	03/28/2024	089076	172.26
<b>Detail Description</b>				<b>Detail Account</b>		<b>Accounting Percent</b>	<b>Detail Amount</b>
books for south campus				10 E 2222 4300 00 300 000000		100.0000%	172.26
<b>Total for Follett School Solutions Inc:</b>							<b>352.65</b>
Fox Valley Fire & Safety Co		IN00673715	DFC	Fire Sprinkler System Repair	04/01/2024	9100002320	2,021.00
<b>Detail Description</b>				<b>Detail Account</b>		<b>Accounting Percent</b>	<b>Detail Amount</b>
Fire Sprinkler System Repair				80 E 2365 3900 00 300 000002		100.0000%	2,021.00
<b>Total for Fox Valley Fire &amp; Safety Co:</b>							<b>2,021.00</b>
Frost, Kathy	1152400097	March 2024 Hours	DFC	Chorus Piano Accompanist Hours for March	03/31/2024	9100002321	756.00
<b>Detail Description</b>				<b>Detail Account</b>		<b>Accounting Percent</b>	<b>Detail Amount</b>
Chorus Piano Accompanist Hours for March (Hours)				10 E 1130 3000 12 300 000001		100.0000%	756.00
<b>Total for Frost, Kathy:</b>							<b>756.00</b>
Full Compass Systems, Ltd.	1042400027	CL-0071148	DFC	Pro Forma - Speaker Repair PAC ***PO Needed***	03/26/2024	089077	956.20
<b>Detail Description</b>				<b>Detail Account</b>		<b>Accounting Percent</b>	<b>Detail Amount</b>
Pro Forma Speaker Repair - PAC ***PO NEEDED***				10 E 1500 5400 70 300 000003		100.0000%	956.20
<b>Total for Full Compass Systems, Ltd.:</b>							<b>956.20</b>
Giant Steps		111-0324S	DFC	Tuition	03/22/2024	9100002322	6,159.68
<b>Detail Description</b>				<b>Detail Account</b>		<b>Accounting Percent</b>	<b>Detail Amount</b>
Tuition				10 E 1912 6700 00 300 000000		100.0000%	6,159.68
<b>Total for Giant Steps:</b>							<b>6,159.68</b>
Gil, Amanda		Lunch Refund	DFC	Lunch Refund	03/20/2024	2551	36.75
<b>Detail Description</b>				<b>Detail Account</b>		<b>Accounting Percent</b>	<b>Detail Amount</b>
Lunch Refund				10 R 1611 0000 00 000 000000		100.0000%	36.75
<b>Total for Gil, Amanda:</b>							<b>36.75</b>

## Invoice Listing

COUNTY OF GRUNDY SCHOOL DIST 111

Vendor	PO Number	Invoice Number	Batch	Description	Invoice Date	Check Number	Net Amount	
Gnat, Dylan		Office Depot Reimb	DFC	Office Depot Reimb	12/13/2023	089078	68.53	
<b>Detail Description</b>				<b>Detail Account</b>		<b>Accounting Percent</b>		<b>Detail Amount</b>
GiC Class Supplies				10 E 1400 4100 10 300 000001		100.0000%		68.53
<b>Total for Gnat, Dylan:</b>							<b>68.53</b>	
Go Bowl Inc	237		DFC	Girls Soccer outing	03/21/2024	23599	296.00	
<b>Detail Description</b>				<b>Detail Account</b>		<b>Accounting Percent</b>		<b>Detail Amount</b>
Outing				11 E 1999 4100 30 300 910019		100.0000%		296.00
Go Bowl Inc	1032400552	239	DFC	Girls Bowling Lane Usage for Bowling Season	03/22/2024	089079	8,837.00	
<b>Detail Description</b>				<b>Detail Account</b>		<b>Accounting Percent</b>		<b>Detail Amount</b>
Girls Bowling Lane Usage for Bowling Season				10 E 1500 3000 30 300 000008		100.0000%		8,837.00
<b>Total for Go Bowl Inc:</b>							<b>9,133.00</b>	
Gordon Food Service	1092400022	9007589414	DFC	GFS Open PO	03/12/2024	089080	204.22	
<b>Detail Description</b>				<b>Detail Account</b>		<b>Accounting Percent</b>		<b>Detail Amount</b>
GFS Open PO				10 E 1420 4100 09 300 000000		100.0000%		204.22
Gordon Food Service	1092400022	9007672340	DFC	GFS Open PO	03/14/2024	089080	52.13	
<b>Detail Description</b>				<b>Detail Account</b>		<b>Accounting Percent</b>		<b>Detail Amount</b>
GFS Open PO				10 E 1420 4100 09 300 000000		100.0000%		52.13
Gordon Food Service	1092400022	9007672342	DFC	GFS Open PO	03/14/2024	089080	631.82	
<b>Detail Description</b>				<b>Detail Account</b>		<b>Accounting Percent</b>		<b>Detail Amount</b>
GFS Open PO				10 E 1420 4100 09 300 000000		100.0000%		631.82
Gordon Food Service	1092400022	9007833325	DFC	GFS Open PO	03/19/2024	089080	243.14	
<b>Detail Description</b>				<b>Detail Account</b>		<b>Accounting Percent</b>		<b>Detail Amount</b>
GFS Open PO				10 E 1420 4100 09 300 000000		100.0000%		243.14
Gordon Food Service	1092400022	9008292111	DFC	GFS Open PO	04/02/2024	089080	163.37	
<b>Detail Description</b>				<b>Detail Account</b>		<b>Accounting Percent</b>		<b>Detail Amount</b>
GFS Open PO				10 E 1420 4100 09 300 000000		100.0000%		163.37
Gordon Food Service	1092400022	9008368438	DFC	GFS Open PO	04/04/2024	089080	568.10	
<b>Detail Description</b>				<b>Detail Account</b>		<b>Accounting Percent</b>		<b>Detail Amount</b>
GFS Open PO				10 E 1420 4100 09 300 000000		100.0000%		568.10

## Invoice Listing

COUNTY OF GRUNDY SCHOOL DIST 111

Vendor	PO Number	Invoice Number	Batch	Description	Invoice Date	Check Number	Net Amount	
Gordon Food Service	1092400022	9008533665	DFC	GFS Open PO	04/09/2024	089080	222.10	
<b>Detail Description</b>				<b>Detail Account</b>		<b>Accounting Percent</b>		<b>Detail Amount</b>
GFS Open PO				10 E 1420 4100 09 300 000000		100.0000%		222.10
<b>Total for Gordon Food Service:</b>							<b>2,084.88</b>	
Grawey-Beeler, Patricia E		Musical Supplies reimb	DFC	Musical Supplies Reimbursement	03/08/2024	9100002323	375.46	
<b>Detail Description</b>				<b>Detail Account</b>		<b>Accounting Percent</b>		<b>Detail Amount</b>
Musical Supplies Reimbursement				10 E 1500 4100 70 300 000004		100.0000%		375.46
<b>Total for Grawey-Beeler, Patricia E:</b>							<b>375.46</b>	
Grundy Area Vocational Ctr		March 2024	DFC	March 2024	03/31/2024	089081	118,775.00	
<b>Detail Description</b>				<b>Detail Account</b>		<b>Accounting Percent</b>		<b>Detail Amount</b>
March 2024				10 E 4140 6000 00 000 000000		76.1066%		90,395.57
March 2024				20 E 4140 6000 00 000 000000		23.8934%		28,379.43
<b>Total for Grundy Area Vocational Ctr:</b>							<b>118,775.00</b>	
Grundy Co Special Education		2024 Winter Formal	DFC	Extra Duties - Winter Formal	04/03/2024	9100002324	91.00 114	
<b>Detail Description</b>				<b>Detail Account</b>		<b>Accounting Percent</b>		<b>Detail Amount</b>
Extra Duties - Winter Formal				10 E 4220 6700 00 000 000000		100.0000%		91.00
Grundy Co Special Education		April 2024 IDEA Flow	DFC	April 2024 IDEA Flow Through	03/20/2024	9100002324	23,320.00	
<b>Detail Description</b>				<b>Detail Account</b>		<b>Accounting Percent</b>		<b>Detail Amount</b>
2024 IDEA Flow Through				10 E 4120 6000 00 000 000000		100.0000%		23,320.00
Grundy Co Special Education		April 2024 Tuition Bill	DFC	April 2024 Tuition Bill	03/20/2024	9100002324	184,895.48	
<b>Detail Description</b>				<b>Detail Account</b>		<b>Accounting Percent</b>		<b>Detail Amount</b>
April 2024 Tuition Bill				10 E 4220 6700 00 000 000000		100.0000%		184,895.48
Grundy Co Special Education		Extra Duties - Battle of	DFC	Extra Duties - Battle of the Classes	03/15/2024	9100002324	175.50	
<b>Detail Description</b>				<b>Detail Account</b>		<b>Accounting Percent</b>		<b>Detail Amount</b>
Extra Duties - Battle of the Classes				10 E 4220 6700 00 000 000000		100.0000%		175.50
Grundy Co Special Education		Extra Duties - MCHS	DFC	Extra Duties - MCHS Musical	03/15/2024	9100002324	182.00	
<b>Detail Description</b>				<b>Detail Account</b>		<b>Accounting Percent</b>		<b>Detail Amount</b>
Extra Duties - MCHS Musical				10 E 4220 6700 00 000 000000		100.0000%		182.00

## Invoice Listing

COUNTY OF GRUNDY SCHOOL DIST 111

Vendor	PO Number	Invoice Number	Batch	Description	Invoice Date	Check Number	Net Amount
Grundy Co Special Education		Winter formal	DFC	Extra Duties Winter Formal	04/04/2024	9100002324	91.00
<b>Detail Description</b>		<b>Detail Account</b>		<b>Accounting Percent</b>		<b>Detail Amount</b>	
Winter Formal Extra Duties		10 E 4220 6700 00 000 000000		100.0000%		91.00	
<b>Total for Grundy Co Special Education:</b>							<b>208,754.98</b>
Guiding Light Academy	6083		DFC	Tuition	04/01/2024	9100002325	14,392.20
<b>Detail Description</b>		<b>Detail Account</b>		<b>Accounting Percent</b>		<b>Detail Amount</b>	
Tuition		10 E 1912 6700 00 300 000000		100.0000%		14,392.20	
<b>Total for Guiding Light Academy:</b>							<b>14,392.20</b>
Helm Mechanical / Helm Service		CHI195744	DFC	Backflow Testing	02/25/2024	089082	3,411.08
<b>Detail Description</b>		<b>Detail Account</b>		<b>Accounting Percent</b>		<b>Detail Amount</b>	
Backflow Testing		20 E 2540 3230 00 300 000000		100.0000%		3,411.08	
<b>Total for Helm Mechanical / Helm Service:</b>							<b>3,411.08</b>
HES Facilities, LLC	104150		DFC	Additional Custodial Services	03/18/2024	089083	2,661.75
<b>Detail Description</b>		<b>Detail Account</b>		<b>Accounting Percent</b>		<b>Detail Amount</b>	
Additional Custodial Services - Winterguard Show		20 E 2540 3900 00 302 000001		100.0000%		2,661.75	
<b>Total for HES Facilities, LLC:</b>							<b>89,368.75</b>
HES Facilities, LLC	104260		DFC	March Services	03/31/2024	089083	86,707.00
<b>Detail Description</b>		<b>Detail Account</b>		<b>Accounting Percent</b>		<b>Detail Amount</b>	
March Services		20 E 2540 3900 00 302 000001		100.0000%		86,707.00	
<b>Total for HES Facilities, LLC:</b>							<b>89,368.75</b>
Hobart Services	35945188		DFC	Vulcan Range Repair	03/16/2024	089084	1,412.44
<b>Detail Description</b>		<b>Detail Account</b>		<b>Accounting Percent</b>		<b>Detail Amount</b>	
Vulcan Range repairs		20 E 2540 3230 00 302 000000		100.0000%		1,412.44	
<b>Total for Hobart Services:</b>							<b>1,412.44</b>
Holden, Hillary A	032024		DFC	Sunblock reimbursement	03/20/2024	9100002326	58.51
<b>Detail Description</b>		<b>Detail Account</b>		<b>Accounting Percent</b>		<b>Detail Amount</b>	
Choir Trip Supplies		10 E 1500 4100 70 300 000006		100.0000%		58.51	
<b>Total for Holden, Hillary A:</b>							<b>58.51</b>
Home Depot Credit Services	972120		DFC	Convection Ranges	03/07/2024	089085	4,119.00
<b>Detail Description</b>		<b>Detail Account</b>		<b>Accounting Percent</b>		<b>Detail Amount</b>	
Convections Ranges		10 E 1420 5400 09 300 000000		100.0000%		4,119.00	

## Invoice Listing

COUNTY OF GRUNDY SCHOOL DIST 111

Vendor	PO Number	Invoice Number	Batch	Description	Invoice Date	Check Number	Net Amount
Home Depot Credit Services	1092400014	2014280	DFC	Open PO	02/14/2024	089085	19.98
<b>Detail Description</b>				<b>Detail Account</b>	<b>Accounting Percent</b>		<b>Detail Amount</b>
Open PO				10 E 1400 4100 10 300 000001	100.0000%		19.98
Home Depot Credit Services	1092400014	3043330	DFC	Open PO	02/13/2024	089085	17.94
<b>Detail Description</b>				<b>Detail Account</b>	<b>Accounting Percent</b>		<b>Detail Amount</b>
Open PO				10 E 1400 4100 10 300 000001	100.0000%		17.94
Home Depot Credit Services	1092400014	4173983	DFC	Open PO	03/03/2024	089085	49.82
<b>Detail Description</b>				<b>Detail Account</b>	<b>Accounting Percent</b>		<b>Detail Amount</b>
Open PO				10 E 1400 4100 10 300 000001	100.0000%		49.82
Home Depot Credit Services	1092400014	5032774	DFC	Open PO	02/21/2024	089085	163.10
<b>Detail Description</b>				<b>Detail Account</b>	<b>Accounting Percent</b>		<b>Detail Amount</b>
Open PO				10 E 1400 4100 10 300 000001	100.0000%		163.10
Home Depot Credit Services	1092400014	6303318	DFC	Open PO	02/20/2024	089085	<del>83.32</del>
<b>Detail Description</b>				<b>Detail Account</b>	<b>Accounting Percent</b>		<b>Detail Amount</b>
Open PO				10 E 1400 4100 10 300 000001	100.0000%		83.32
Home Depot Credit Services	1092400014	7614771	DFC	Open PO	02/19/2024	089085	105.09
<b>Detail Description</b>				<b>Detail Account</b>	<b>Accounting Percent</b>		<b>Detail Amount</b>
Open PO				10 E 1400 4100 10 300 000001	100.0000%		105.09
Home Depot Credit Services	1092400014	9043299	DFC	Open PO	03/08/2024	089085	64.94
<b>Detail Description</b>				<b>Detail Account</b>	<b>Accounting Percent</b>		<b>Detail Amount</b>
Open PO				10 E 1400 4100 10 300 000001	100.0000%		64.94
<b>Total for Home Depot Credit Services:</b>							<b>4,623.19</b>
Hopewell Career Academy, Inc.		408803	DFC	Tuition	03/18/2024	9100002327	8,599.20
<b>Detail Description</b>				<b>Detail Account</b>	<b>Accounting Percent</b>		<b>Detail Amount</b>
Tuition				10 E 1912 6700 00 300 000000	100.0000%		8,599.20

## Invoice Listing

COUNTY OF GRUNDY SCHOOL DIST 111

Vendor	PO Number	Invoice Number	Batch	Description	Invoice Date	Check Number	Net Amount
Hopewell Career Academy, Inc.		4805	DFC	Tuition	03/18/2024	9100002327	39,886.74
<b>Detail Description</b>		<b>Detail Account</b>		<b>Accounting Percent</b>		<b>Detail Amount</b>	
Tuition		10 E 1912 6700 00 300 000000		100.0000%		39,886.74	
<b>Total for Hopewell Career Academy, Inc.:</b>							<b>48,485.94</b>
Illco		6201737	DFC	Filters	03/13/2024	089086	839.72
<b>Detail Description</b>		<b>Detail Account</b>		<b>Accounting Percent</b>		<b>Detail Amount</b>	
Filters		20 E 2540 3230 00 300 000000		100.0000%		839.72	
Illco		6201738	DFC	Supplies	03/13/2024	089086	742.13
<b>Detail Description</b>		<b>Detail Account</b>		<b>Accounting Percent</b>		<b>Detail Amount</b>	
Supplies		20 E 2540 3230 00 300 000000		100.0000%		742.13	
Illco		6201801	DFC	Supplies	03/15/2024	089086	70.30
<b>Detail Description</b>		<b>Detail Account</b>		<b>Accounting Percent</b>		<b>Detail Amount</b>	
Copper Clevis Hanger		20 E 2540 4100 00 300 000000		100.0000%		70.30	
<b>Total for Illco:</b>							<b>1,652.15</b>
Illinois Association of School Boards		430740	DFC	Illinois council of school attorneys	01/08/2024	089087	42.50 117
<b>Detail Description</b>		<b>Detail Account</b>		<b>Accounting Percent</b>		<b>Detail Amount</b>	
Illinois Council of School Attorneys		10 E 2510 6400 00 300 000000		100.0000%		42.50	
<b>Total for Illinois Association of School Boards:</b>							<b>42.50</b>
Illinois Principals Association	1192400012	443455	DFC	Illinois Principals Association Matthew Shanahan Professional Development-What Went Wrong: How to Avoid Special Ed Litigation	03/21/2024	089088	299.00
<b>Detail Description</b>		<b>Detail Account</b>		<b>Accounting Percent</b>		<b>Detail Amount</b>	
Illinois Principals Association Matthew Shanahan Professional Development-What Went Wrong: How to Avoid Special Ed Litigation		10 E 2210 3000 00 300 000002		100.0000%		299.00	
<b>Total for Illinois Principals Association:</b>							<b>299.00</b>
Illinois Public Risk Fund		85764	DFC	May Worker's Comp Insurance	03/18/2024	089089	19,518.00
<b>Detail Description</b>		<b>Detail Account</b>		<b>Accounting Percent</b>		<b>Detail Amount</b>	
May Worker's Comp Insurance		80 E 2362 3800 00 300 000000		100.0000%		19,518.00	
<b>Total for Illinois Public Risk Fund:</b>							<b>19,518.00</b>

## Invoice Listing

COUNTY OF GRUNDY SCHOOL DIST 111

Vendor	PO Number	Invoice Number	Batch	Description	Invoice Date	Check Number	Net Amount	
Illinois State Police		20240303074	DFC	March Fingerprinting	03/31/2024	089090	113.00	
<b>Detail Description</b>				<b>Detail Account</b>		<b>Accounting Percent</b>		<b>Detail Amount</b>
March Fingerprinting				10 E 2310 4100 00 300 000000		100.0000%		113.00
<b>Total for Illinois State Police:</b>							<b>113.00</b>	
Instrumentalist Awards		60447M2401	DFC	Awards	03/14/2024	089091	308.00	
<b>Detail Description</b>				<b>Detail Account</b>		<b>Accounting Percent</b>		<b>Detail Amount</b>
Awards				10 E 1130 4100 12 300 000000		100.0000%		308.00
<b>Total for Instrumentalist Awards:</b>							<b>308.00</b>	
ITR Systems - Division of AANEVCO, Inc.		107236-P	DFC	Wired Wall Clocks	03/26/2024	089092	460.00	
<b>Detail Description</b>				<b>Detail Account</b>		<b>Accounting Percent</b>		<b>Detail Amount</b>
Wired Wall Clocks				20 E 2540 4100 00 302 000000		100.0000%		460.00
ITR Systems - Division of AANEVCO, Inc.	1022400089	107207-S	DFC	AI Phone Install at back door (delivery door @ central campus).	03/18/2024	089092	7,480.00	
<b>Detail Description</b>				<b>Detail Account</b>		<b>Accounting Percent</b>		<b>Detail Amount</b>
AI Phone IX-DVM Door station and relay Equipment				80 E 2546 5400 00 300 000000		100.0000%		5,795.00
Cabling cat6e				80 E 2546 5400 00 300 000000		100.0000%		1,685.00
<b>Total for ITR Systems - Division of AANEVCO, Inc.:</b>							<b>7,940.00</b>	
J.W. Pepper & Son Inc.	1152400080	366309901	DFC	Chorus Spring Music	03/19/2024	9100002328	34.45	
<b>Detail Description</b>				<b>Detail Account</b>		<b>Accounting Percent</b>		<b>Detail Amount</b>
P 3295641 New York State of Mind-B. Joel/arr. S. Zegree (SSA)				10 E 1130 4100 12 300 000001		100.0000%		34.45
J.W. Pepper & Son Inc.	1152400089	366321615	DFC	Marching band piece	03/22/2024	9100002328	77.99	
<b>Detail Description</b>				<b>Detail Account</b>		<b>Accounting Percent</b>		<b>Detail Amount</b>
10045145 Marching Band - You give Love a Band Name- Bon Jovi UPC: 884088222932				10 E 1130 4100 12 300 000000		100.0000%		77.99
<b>Total for J.W. Pepper &amp; Son Inc.:</b>							<b>112.44</b>	
Kimball Midwest		102008553	DFC	Supplies	03/12/2024	9100002329	2,386.66	
<b>Detail Description</b>				<b>Detail Account</b>		<b>Accounting Percent</b>		<b>Detail Amount</b>
Supplies				20 E 2540 4100 00 300 000000		100.0000%		2,386.66
Kimball Midwest		102016250	DFC	Supplies	03/14/2024	9100002329	272.34	
<b>Detail Description</b>				<b>Detail Account</b>		<b>Accounting Percent</b>		<b>Detail Amount</b>
Supplies				20 E 2540 4100 00 300 000000		100.0000%		272.34

## Invoice Listing

COUNTY OF GRUNDY SCHOOL DIST 111

Vendor	PO Number	Invoice Number	Batch	Description	Invoice Date	Check Number	Net Amount
Kimball Midwest		102018186	DFC	Credit for item shorted	03/14/2024	9100002329	-23.75
<b>Detail Description</b>		<b>Detail Account</b>		<b>Accounting Percent</b>		<b>Detail Amount</b>	
Credit for item shorted		20 E 2540 4100 00 300 000000		100.0000%		-23.75	
<b>Total for Kimball Midwest:</b>							<b>2,635.25</b>
Learnwell		INV182766	DFC	Tutoring	03/08/2024	089093	472.80
<b>Detail Description</b>		<b>Detail Account</b>		<b>Accounting Percent</b>		<b>Detail Amount</b>	
Tutoring		10 E 1200 6700 00 300 000002		100.0000%		472.80	
Learnwell		INV182767	DFC	Tutoring	03/08/2024	089093	472.80
<b>Detail Description</b>		<b>Detail Account</b>		<b>Accounting Percent</b>		<b>Detail Amount</b>	
Tutoring		10 E 1200 6700 00 300 000002		100.0000%		472.80	
Learnwell		INV184111	DFC	Tutoring	03/15/2024	089093	236.40
<b>Detail Description</b>		<b>Detail Account</b>		<b>Accounting Percent</b>		<b>Detail Amount</b>	
Tutoring		10 E 1200 6700 00 300 000002		100.0000%		236.40	
Learnwell		INV184112	DFC	Tutoring	03/15/2024	089093	394.00
<b>Detail Description</b>		<b>Detail Account</b>		<b>Accounting Percent</b>		<b>Detail Amount</b>	
Tutoring		10 E 1200 6700 00 300 000002		100.0000%		394.00	
Learnwell		INV184113	DFC	Tutoring	03/15/2024	089093	118.20
<b>Detail Description</b>		<b>Detail Account</b>		<b>Accounting Percent</b>		<b>Detail Amount</b>	
Tutoring		10 E 1200 6700 00 300 000002		100.0000%		118.20	
Learnwell		INV185074	DFC	Tutoring	03/22/2024	089093	472.80
<b>Detail Description</b>		<b>Detail Account</b>		<b>Accounting Percent</b>		<b>Detail Amount</b>	
Tutoring		10 E 1200 6700 00 300 000002		100.0000%		472.80	
Learnwell		INV185075	DFC	Tutoring	03/22/2024	089093	472.80
<b>Detail Description</b>		<b>Detail Account</b>		<b>Accounting Percent</b>		<b>Detail Amount</b>	
Tutoring		10 E 1200 6700 00 300 000002		100.0000%		472.80	
Learnwell		INV185076	DFC	Tutoring	03/22/2024	089093	1,379.06
<b>Detail Description</b>		<b>Detail Account</b>		<b>Accounting Percent</b>		<b>Detail Amount</b>	
Tutoring		10 E 1200 6700 00 300 000002		100.0000%		1,379.06	
<b>Total for Learnwell:</b>							<b>4,018.86</b>

## Invoice Listing

COUNTY OF GRUNDY SCHOOL DIST 111

Vendor	PO Number	Invoice Number	Batch	Description	Invoice Date	Check Number	Net Amount
MARCIA BRENNER ASSOCIATES	1022400102	INV-2404411	DFC	MBA Reports Plugin to replace Phoenix Learning Software/Customizations. Prorated for 3 months and 1 time implementation fee.	03/14/2024	089094	2,531.25
				<b>Detail Description</b>			<b>Detail Account</b>
				One time Implementation Fee			10 E 2225 4700 00 300 000000
				Report Creator Plugin			10 E 2225 4700 00 300 000000
				<b>Total for MARCIA BRENNER ASSOCIATES:</b>			<b>2,531.25</b>
Marino, Matthew J, Sr		Conference Reimb	DFC	Annual Conference Reimbursement	04/05/2024	9100002330	185.00
				<b>Detail Description</b>			<b>Detail Account</b>
				CSCA Ticket Cost			10 E 2210 3000 15 300 000000
				<b>Total for Marino, Matthew J, Sr:</b>			<b>185.00</b>
McFee, Conda K		Reach Volleyball Team	DFC	Reach Volleyball Team	04/09/2024	089095	52.00
				<b>Detail Description</b>			<b>Detail Account</b>
				Reach Volleyball Team			10 E 1500 1300 30 300 000002
				<b>Total for McFee, Conda K:</b>			<b>52.00</b>
McHs Band Boosters	1152400092	041024	DFC	MCHS SOLO and ENSEMBLE reimbursement	04/10/2024	089096	1,400.00
				<b>Detail Description</b>			<b>Detail Account</b>
				MCHS SOLO and ENSEMBLE JUDGES Reimbursement			10 E 1130 3000 12 300 000000
				<b>Total for MchS Band Boosters:</b>			<b>1,400.00</b>
McHs P-Card		04/05/24 Statement	DFC	Winterguard Homeshow	04/05/2024	23600	4,756.47
				<b>Detail Description</b>			<b>Detail Account</b>
				Homeshow			11 E 1999 4100 70 300 900051
McHs P-Card		04/05/24 Statemetn	DFC	Flint Michigan Trip	04/05/2024	23600	2,407.70
				<b>Detail Description</b>			<b>Detail Account</b>
				Flint Michigan Trip			11 E 1999 4100 70 300 900051

## Invoice Listing

COUNTY OF GRUNDY SCHOOL DIST 111

Vendor	PO Number	Invoice Number	Batch	Description	Invoice Date	Check Number	Net Amount
McHs P-Card		4/5/24 Statement	DFC	Fair Oaks Field Trip	04/05/2024	23600	351.50
<b>Detail Description</b>		<b>Detail Account</b>		<b>Accounting Percent</b>		<b>Detail Amount</b>	
Fair Oaks Fieldtrip		11 E 1999 4100 70 300 900062		100.0000%		351.50	
McHs P-Card		4/5/24 Statement	DFC	Monthly Meeting & Breakfast	04/05/2024	23600	346.13
<b>Detail Description</b>		<b>Detail Account</b>		<b>Accounting Percent</b>		<b>Detail Amount</b>	
Monthly meeting & breakfast		11 E 1999 4100 30 300 910002		100.0000%		346.13	
McHs P-Card		4/5/24 Statement	DFC	2024 Spring Conference	04/05/2024	23600	100.00
<b>Detail Description</b>		<b>Detail Account</b>		<b>Accounting Percent</b>		<b>Detail Amount</b>	
2024 Spring Conference		11 E 1999 4100 30 300 910012		100.0000%		100.00	
McHs P-Card		4/5/24 Statement	DFC	EIBurrito	04/05/2024	23600	514.65
<b>Detail Description</b>		<b>Detail Account</b>		<b>Accounting Percent</b>		<b>Detail Amount</b>	
ELBurrito		11 E 1999 4100 30 300 910019		100.0000%		514.65	
McHs P-Card		4/5/24 Statement	DFC	Customlnk	04/05/2024	23600	483.07
<b>Detail Description</b>		<b>Detail Account</b>		<b>Accounting Percent</b>		<b>Detail Amount</b>	
Customlnk		11 E 1999 4100 30 300 910023		100.0000%		483.07	
McHs P-Card		4/5/24 Statement	DFC	Pizza For U	04/05/2024	23600	214.17
<b>Detail Description</b>		<b>Detail Account</b>		<b>Accounting Percent</b>		<b>Detail Amount</b>	
Pizza For U		11 E 1999 4100 30 300 910005		100.0000%		214.17	
McHs P-Card	2032400137	4/5/24 Statement	DFC	Girls Soccer Wristbands	04/05/2024	23600	64.00
<b>Detail Description</b>		<b>Detail Account</b>		<b>Accounting Percent</b>		<b>Detail Amount</b>	
Girls Soccer Wristbands		11 E 1999 4100 30 300 910019		100.0000%		64.00	
McHs P-Card	2032400144	4/5/24 Statement	DFC	Girls Basketball Olivet Summer Shootout	04/05/2024	23600	275.00
<b>Detail Description</b>		<b>Detail Account</b>		<b>Accounting Percent</b>		<b>Detail Amount</b>	
Girls Basketball Olivet Summer Shootout		11 E 1999 4100 30 300 910016		100.0000%		275.00	
McHs P-Card	2032400147	4/5/24 Statement	DFC	Baseball Mound Clay	04/05/2024	23600	422.00
<b>Detail Description</b>		<b>Detail Account</b>		<b>Accounting Percent</b>		<b>Detail Amount</b>	
Baseball Mound Clay		11 E 1999 4100 30 300 910004		100.0000%		422.00	

## Invoice Listing

COUNTY OF GRUNDY SCHOOL DIST 111

Vendor	PO Number	Invoice Number	Batch	Description	Invoice Date	Check Number	Net Amount
McHs P-Card	2042400047	4/5/24 Statement	DFC	March Activity Statement P-card	04/05/2024	23600	2,290.05
				<b>Detail Description</b>	<b>Detail Account</b>	<b>Accounting Percent</b>	<b>Detail Amount</b>
				Ace Hardware	11 E 1999 4100 70 300 900008	0.0000%	0.00
				Giordano's	11 E 1999 4100 70 300 900045	100.0000%	110.50
				Ready Refresh	11 E 1999 4100 70 300 900040	0.0000%	0.00
				Wyndham	11 E 1999 4100 70 300 900048	0.0000%	0.00
				Epic Sports	11 E 1999 4100 70 300 900048	100.0000%	1,023.38
				Gorden Foods	11 E 1999 4100 70 300 900040	100.0000%	109.46
				Gordon Foods Musical Supplies	11 E 1999 4100 70 300 900040	100.0000%	744.31
				TSA Store Order Confirmation #65084 #17	11 E 1999 4100 70 300 900049	100.0000%	297.00
				Eventlink	11 E 1999 4100 70 300 900051	100.0000%	5.40
				Winterguard test link			
<b>Total for McHs P-Card:</b>							<b>12,224.74</b>
Menards	21388		DFC	Supplies	02/29/2024	9100002331	905.94
				<b>Detail Description</b>	<b>Detail Account</b>	<b>Accounting Percent</b>	<b>Detail Amount</b>
				IPRF Grant	20 E 2540 4100 00 300 000001	100.0000%	905.94
Menards	21755		DFC	Supplies	03/06/2024	9100002331	57.07
				<b>Detail Description</b>	<b>Detail Account</b>	<b>Accounting Percent</b>	<b>Detail Amount</b>
				Supplies	20 E 2540 4100 00 302 000000	100.0000%	57.07
Menards	21793		DFC	Supplies	03/06/2024	9100002331	46.14
				<b>Detail Description</b>	<b>Detail Account</b>	<b>Accounting Percent</b>	<b>Detail Amount</b>
				Musical Supplies	10 E 1500 4100 70 300 000004	100.0000%	46.14
Menards	21831		DFC	Supplies	03/07/2024	9100002331	45.70
				<b>Detail Description</b>	<b>Detail Account</b>	<b>Accounting Percent</b>	<b>Detail Amount</b>
				Supplies	20 E 2540 4100 00 302 000000	100.0000%	45.70
Menards	22010		DFC	Musical Supplies	03/09/2024	9100002331	70.64
				<b>Detail Description</b>	<b>Detail Account</b>	<b>Accounting Percent</b>	<b>Detail Amount</b>
				Musical Supplies	10 E 1500 4100 70 300 000004	100.0000%	70.64
Menards	22089		DFC	Supplies	03/11/2024	9100002331	31.48
				<b>Detail Description</b>	<b>Detail Account</b>	<b>Accounting Percent</b>	<b>Detail Amount</b>
				Supplies	20 E 2540 4100 00 302 000000	100.0000%	31.48

## Invoice Listing

COUNTY OF GRUNDY SCHOOL DIST 111

Vendor	PO Number	Invoice Number	Batch	Description	Invoice Date	Check Number	Net Amount
Menards		22391	DFC	Supplies	03/15/2024	9100002331	162.86
<b>Detail Description</b>		<b>Detail Account</b>		<b>Accounting Percent</b>		<b>Detail Amount</b>	
				Supplies			162.86
				20 E 2540 4100 00 302 000000			100.0000%
Menards		22622	DFC	Return	03/19/2024	9100002331	-74.97
<b>Detail Description</b>		<b>Detail Account</b>		<b>Accounting Percent</b>		<b>Detail Amount</b>	
				Return			-74.97
				20 E 2540 4100 00 302 000000			100.0000%
Menards		22624	DFC	Supplies	03/19/2024	9100002331	89.96
<b>Detail Description</b>		<b>Detail Account</b>		<b>Accounting Percent</b>		<b>Detail Amount</b>	
				Supplies			89.96
				20 E 2540 4100 00 302 000000			100.0000%
Menards		22709	DFC	Supplies	03/20/2024	9100002331	167.03
<b>Detail Description</b>		<b>Detail Account</b>		<b>Accounting Percent</b>		<b>Detail Amount</b>	
				Supplies			167.03
				20 E 2540 4100 00 300 000000			100.0000%
Menards		22985	DFC	Supplies	03/25/2024	9100002331	199.92
<b>Detail Description</b>		<b>Detail Account</b>		<b>Accounting Percent</b>		<b>Detail Amount</b>	
				Supplies			199.92
				20 E 2540 4100 00 302 000000			100.0000%
Menards		23001	DFC	Supplies	03/25/2024	9100002331	240.65
<b>Detail Description</b>		<b>Detail Account</b>		<b>Accounting Percent</b>		<b>Detail Amount</b>	
				Supplies			240.65
				20 E 2540 4100 00 300 000000			100.0000%
Menards		23051	DFC	Supplies	03/26/2024	9100002331	45.52
<b>Detail Description</b>		<b>Detail Account</b>		<b>Accounting Percent</b>		<b>Detail Amount</b>	
				Supplies			45.52
				20 E 2540 4100 00 302 000000			100.0000%
Menards		23189	DFC	Supplies	03/28/2024	9100002331	85.33
<b>Detail Description</b>		<b>Detail Account</b>		<b>Accounting Percent</b>		<b>Detail Amount</b>	
				Supplies			85.33
				20 E 2540 4100 00 302 000000			100.0000%
Menards		23205	DFC	Supplies	03/28/2024	9100002331	377.37
<b>Detail Description</b>		<b>Detail Account</b>		<b>Accounting Percent</b>		<b>Detail Amount</b>	
				Salt Pellets			377.37
				20 E 2540 4100 00 302 000000			100.0000%
Menards		23264	DFC	Supplies	03/29/2024	9100002331	89.87
<b>Detail Description</b>		<b>Detail Account</b>		<b>Accounting Percent</b>		<b>Detail Amount</b>	
				Supplies			89.87
				20 E 2540 4100 00 302 000000			100.0000%

## Invoice Listing

COUNTY OF GRUNDY SCHOOL DIST 111

Vendor	PO Number	Invoice Number	Batch	Description	Invoice Date	Check Number	Net Amount	
Menards		23421	DFC	Supplies	04/01/2024	9100002331	334.48	
				<b>Detail Description</b>	<b>Detail Account</b>		<b>Accounting Percent</b>	<b>Detail Amount</b>
				Supplies	20 E 2540 4100 00 302 000000		100.0000%	334.48
							<b>Total for Menards:</b>	<b>2,874.99</b>
M-F Athletic Company Inc.	1032400546	INV277426	DFC	Girls Track Equipment	03/21/2024	089097	710.90	
				<b>Detail Description</b>	<b>Detail Account</b>		<b>Accounting Percent</b>	<b>Detail Amount</b>
				Implement Scale	10 E 1500 5400 30 300 000000		100.0000%	129.00
				First Place Mini Band 02 Pack of 10 Medium Green	10 E 1500 5400 30 300 000000		100.0000%	41.90
				Economy Open Reel Fiberglass Measuring Tape (100' / 30m) • LIFETIME WARRANTY	10 E 1500 5400 30 300 000000		100.0000%	24.00
				Komelon Fiberglass Measuring Tape 100'	10 E 1500 5400 30 300 000000		100.0000%	70.00
				Komelon Fiberglass Measuring Tape 200'	10 E 1500 5400 30 300 000000		100.0000%	58.00
				Official's Helper (Set of 4)	10 E 1500 5400 30 300 000000		100.0000%	60.00
				Sector Template	10 E 1500 5400 30 300 000000		100.0000%	<del>75.00</del>
				Pyramid Spikes Bag of 100 1/8"	10 E 1500 5400 30 300 000000		100.0000%	39.00
				Pyramid Spikes Bag of 100 1/4"	10 E 1500 5400 30 300 000000		100.0000%	26.00
				Pyramid Spikes Bag of 100 1/4" ** FREE SPECIAL **	10 E 1500 5400 30 300 000000		0.0000%	0.00
				Hip Numbers Lanes 10-18 (25 of each number)	10 E 1500 5400 30 300 000000		100.0000%	32.00
				Hip Numbers Lanes 1-8 (250 of each number)	10 E 1500 5400 30 300 000000		100.0000%	107.00
				Shipping	10 E 1500 5400 30 300 000000		100.0000%	49.00
							<b>Total for M-F Athletic Company Inc.:</b>	<b>710.90</b>
Midwest Bus Leasing		INV21284	DFC	Bus Lease	01/09/2024	089144	19,046.32	
				<b>Detail Description</b>	<b>Detail Account</b>		<b>Accounting Percent</b>	<b>Detail Amount</b>
				Bus Leases	40 E 2550 3200 00 000 000000		100.0000%	19,046.32
							<b>Total for Midwest Bus Leasing:</b>	<b>19,046.32</b>
Midwest Bus Sales		C050066963:01	DFC	Supplies	03/18/2024	089098	52.68	
				<b>Detail Description</b>	<b>Detail Account</b>		<b>Accounting Percent</b>	<b>Detail Amount</b>
				Valves	40 E 2552 4100 00 300 000001		100.0000%	52.68

## Invoice Listing

COUNTY OF GRUNDY SCHOOL DIST 111

Vendor	PO Number	Invoice Number	Batch	Description	Invoice Date	Check Number	Net Amount
Midwest Bus Sales		C050067023:01	DFC	Supplies	03/20/2024	089098	36.40
<b>Detail Description</b>		<b>Detail Account</b>		<b>Accounting Percent</b>		<b>Detail Amount</b>	
Supplies		40 E 2552 4100 00 300 000001		100.0000%		36.40	
Midwest Bus Sales		R050027830:01	DFC	Customer Lease Return Damage Penalty	08/17/2023	089098	3,805.80
<b>Detail Description</b>		<b>Detail Account</b>		<b>Accounting Percent</b>		<b>Detail Amount</b>	
Customer Lease Return Damage Penalty		40 E 2554 3230 00 300 000000		100.0000%		4,623.52	
Customer Lease Return Damage Penalty		40 E 2554 3230 00 300 000000		100.0000%		-817.72	
Midwest Bus Sales		R050027831:01	DFC	Customer Lease Return Damage Penalty	08/17/2023	089098	9,259.45
<b>Detail Description</b>		<b>Detail Account</b>		<b>Accounting Percent</b>		<b>Detail Amount</b>	
Customer Lease Return Damage Penalty		40 E 2554 3230 00 300 000000		100.0000%		9,753.85	
Customer Lease Return Damage Penalty		40 E 2554 3230 00 300 000000		100.0000%		-494.40	
Midwest Bus Sales		R050027832:01	DFC	Customer Lease Return Damage Penalty	08/17/2023	089098	10,911.91
<b>Detail Description</b>		<b>Detail Account</b>		<b>Accounting Percent</b>		<b>Detail Amount</b>	
Customer Lease Return Damage Penalty		40 E 2554 3230 00 300 000000		100.0000%		11,648.77	
Customer Lease Return Damage Penalty		40 E 2554 3230 00 300 000000		100.0000%		-736.86	
Midwest Bus Sales		R050027834:01	DFC	Customer Lease Return Damage Penalty	08/17/2023	089098	4,050.93
<b>Detail Description</b>		<b>Detail Account</b>		<b>Accounting Percent</b>		<b>Detail Amount</b>	
Customer Lease Return Damage Penalty		40 E 2554 3230 00 300 000000		100.0000%		4,572.75	
Customer Lease Return Damage Penalty		40 E 2554 3230 00 300 000000		100.0000%		-521.82	
Midwest Bus Sales		R050027838:01	DFC	Customer Lease Return Damage Penalty	08/17/2023	089098	6,454.60
<b>Detail Description</b>		<b>Detail Account</b>		<b>Accounting Percent</b>		<b>Detail Amount</b>	
Customer Lease Return Damage Penalty		40 E 2554 3230 00 300 000000		100.0000%		7,476.49	
Customer Lease Return Damage Penalty		40 E 2554 3230 00 300 000000		100.0000%		-1,021.89	
Midwest Bus Sales		R050027839:01	DFC	Customer Lease Return Damage Penalty	08/17/2023	089098	3,149.46
<b>Detail Description</b>		<b>Detail Account</b>		<b>Accounting Percent</b>		<b>Detail Amount</b>	
Customer Lease Return Damage Penalty		40 E 2554 3230 00 300 000000		100.0000%		4,490.08	
Customer Lease Return Damage Penalty		40 E 2554 3230 00 300 000000		100.0000%		-1,340.62	
Midwest Bus Sales		R050027840:01	DFC	Customer Lease Return Damage Penalty	08/17/2023	089098	6,026.18
<b>Detail Description</b>		<b>Detail Account</b>		<b>Accounting Percent</b>		<b>Detail Amount</b>	
Customer Lease Return Damage Penalty		40 E 2554 3230 00 300 000000		100.0000%		6,700.07	
Customer Lease Return Damage Penalty		40 E 2554 3230 00 300 000000		100.0000%		-673.89	

## Invoice Listing

COUNTY OF GRUNDY SCHOOL DIST 111

Vendor	PO Number	Invoice Number	Batch	Description	Invoice Date	Check Number	Net Amount
Midwest Bus Sales		R050027842:01	DFC	Customer Lease Return Damage Penalty	08/17/2023	089098	4,957.74
		<b>Detail Description</b>	<b>Detail Account</b>		<b>Accounting Percent</b>		<b>Detail Amount</b>
		Customer Lease Return Damage Penalty	40 E 2554 3230 00 300 000000		100.0000%		6,530.46
		Customer Lease Return Damage Penalty	40 E 2554 3230 00 300 000000		100.0000%		-1,572.72
Midwest Bus Sales		R050027843:01	DFC	Customer Lease Return Damage Penalty	08/17/2023	089098	10,230.22
		<b>Detail Description</b>	<b>Detail Account</b>		<b>Accounting Percent</b>		<b>Detail Amount</b>
		Customer Lease Return Damage Penalty	40 E 2554 3230 00 300 000000		100.0000%		11,496.32
		Customer Lease Return Damage Penalty	40 E 2554 3230 00 300 000000		100.0000%		-1,266.10
Midwest Bus Sales		R050027844:01	DFC	Customer Lease Return Damage Penalty	08/17/2023	089098	7,843.73
		<b>Detail Description</b>	<b>Detail Account</b>		<b>Accounting Percent</b>		<b>Detail Amount</b>
		Customer Lease Return Damage Penalty	40 E 2554 3230 00 300 000000		100.0000%		9,066.65
		Customer Lease Return Damage Penalty	40 E 2554 3230 00 300 000000		100.0000%		-1,222.92
						<b>Total for Midwest Bus Sales:</b>	<b>66,779.10</b>

## Invoice Listing

COUNTY OF GRUNDY SCHOOL DIST 111

Vendor	PO Number	Invoice Number	Batch	Description	Invoice Date	Check Number	Net Amount
Minooka CCSD #201		4/24 Transportation Split	DFC	Transportation Split	04/01/2024	9100002332	9,513.15
		<b>Detail Description</b>	<b>Detail Account</b>		<b>Accounting Percent</b>		<b>Detail Amount</b>
		Quench	40 E 2552 4100 00 300 000000		100.0000%		33.00
		Rival5	40 E 2550 3400 00 300 000000		100.0000%		55.80
		Nicor	40 E 2552 4650 00 300 000000		100.0000%		306.66
		Waste Management	40 E 2550 3210 00 300 000000		100.0000%		773.31
		Waste Management	40 E 2550 3210 00 300 000000		100.0000%		766.13
		Waste Management	40 E 2550 3210 00 300 000000		100.0000%		757.56
		Waste Management	40 E 2550 3210 00 300 000000		100.0000%		757.56
		Waste Management	40 E 2550 3210 00 300 000000		100.0000%		8.34
		Waste Management	40 E 2550 3210 00 300 000000		100.0000%		8.34
		Document Imaging	40 E 2552 4100 00 300 000000		100.0000%		205.00
		Document Imaging	40 E 2552 4100 00 300 000000		100.0000%		159.00
		Goldy Locks	40 E 2552 4100 00 300 000000		100.0000%		71.38
		Smithereen	40 E 2554 3000 00 300 000000		100.0000%		30.00
		Menards	40 E 2552 4100 00 300 000000		100.0000%		21.89
		Rival5	40 E 2550 3400 00 300 000000		100.0000%		55.80
		Radi-Link	40 E 2554 3230 00 300 000000		100.0000%		230.00
		Waste Management	40 E 2550 3210 00 300 000000		100.0000%		761.08
		Wunderlich Doors	40 E 2559 5300 00 300 000000		100.0000%		4,262.50
		Nicor	40 E 2552 4650 00 300 000000		100.0000%		249.80
						<b>Total for Minooka CCSD #201:</b>	<b>9,513.15</b>
Minooka Fire Protection District		04042024	DFC	HS 1st Aid Class	04/04/2024	089099	430.00
		<b>Detail Description</b>	<b>Detail Account</b>		<b>Accounting Percent</b>		<b>Detail Amount</b>
		HS 1st Aid Class	40 E 2540 3390 00 300 000000		100.0000%		430.00
						<b>Total for Minooka Fire Protection District:</b>	<b>430.00</b>
Minooka Grain Lumber & Sup.		269645	DFC	Supplies	04/02/2024	9100002333	151.96
		<b>Detail Description</b>	<b>Detail Account</b>		<b>Accounting Percent</b>		<b>Detail Amount</b>
		Supplies	20 E 2540 4100 00 300 000000		100.0000%		151.96

## Invoice Listing

COUNTY OF GRUNDY SCHOOL DIST 111

Vendor	PO Number	Invoice Number	Batch	Description	Invoice Date	Check Number	Net Amount
Minooka Grain Lumber & Sup.	1092400013	269496	DFC	Open PO	03/19/2024	9100002333	421.98
<b>Detail Description</b>				<b>Detail Account</b>		<b>Accounting Percent</b>	<b>Detail Amount</b>
Open PO				10 E 1400 4100 10 300 000001		100.0000%	421.98
Minooka Grain Lumber & Sup.	1092400013	269501	DFC	Open PO	03/19/2024	9100002333	19.98
<b>Detail Description</b>				<b>Detail Account</b>		<b>Accounting Percent</b>	<b>Detail Amount</b>
Open PO				10 E 1400 4100 10 300 000001		100.0000%	19.98
Minooka Grain Lumber & Sup.	1092400013	269653	DFC	Open PO	04/02/2024	9100002333	205.00
<b>Detail Description</b>				<b>Detail Account</b>		<b>Accounting Percent</b>	<b>Detail Amount</b>
Open PO				10 E 1400 4100 10 300 000001		100.0000%	205.00
Minooka Grain Lumber & Sup.	1092400013	269654	DFC	Open PO	04/02/2024	9100002333	123.00
<b>Detail Description</b>				<b>Detail Account</b>		<b>Accounting Percent</b>	<b>Detail Amount</b>
Open PO				10 E 1400 4100 10 300 000001		100.0000%	123.00
<b>Total for Minooka Grain Lumber &amp; Sup.:</b>							<b>921.92</b>
Morris Community High School		Ladies Summer Shootout	DFC	Ladies Summer Shootout	04/04/2024	23601	350.00
<b>Detail Description</b>				<b>Detail Account</b>		<b>Accounting Percent</b>	<b>Detail Amount</b>
Ladies Summer Shootout				11 E 1999 4100 30 300 910016		100.0000%	350.00
<b>Total for Morris Community High School:</b>							<b>350.00</b>
Morris Hospital		00027391-00	DFC	Bus Physical	01/11/2024	9100002334	141.00
<b>Detail Description</b>				<b>Detail Account</b>		<b>Accounting Percent</b>	<b>Detail Amount</b>
Bus Physical				40 E 2550 3100 00 300 000000		100.0000%	141.00
Morris Hospital		00028004-00	DFC	Drug Screenings	03/26/2024	9100002334	42.00
<b>Detail Description</b>				<b>Detail Account</b>		<b>Accounting Percent</b>	<b>Detail Amount</b>
Drug Screenings				40 E 2550 3100 00 300 000000		100.0000%	42.00
Morris Hospital		00028080-00	DFC	Drug Screenings & Physicals	04/02/2024	9100002334	312.00
<b>Detail Description</b>				<b>Detail Account</b>		<b>Accounting Percent</b>	<b>Detail Amount</b>
Drug Screenings & Physicals				40 E 2550 3100 00 300 000000		100.0000%	312.00

## Invoice Listing

COUNTY OF GRUNDY SCHOOL DIST 111

Vendor	PO Number	Invoice Number	Batch	Description	Invoice Date	Check Number	Net Amount	
Morris Hospital		00028081-00	DFC	Physical & DrugScreening	04/02/2024	9100002334	163.00	
<b>Detail Description</b>				<b>Detail Account</b>		<b>Accounting Percent</b>		<b>Detail Amount</b>
Physical & Drug Screening				40 E 2550 3100 00 300 000000		100.0000%		163.00
<b>Total for Morris Hospital:</b>							<b>658.00</b>	
Murnane Paper Company	1022400100	227225	DFC	Recycled Paper for Small Printers At Central Campus	03/14/2024	089100	1,856.00	
<b>Detail Description</b>				<b>Detail Account</b>		<b>Accounting Percent</b>		<b>Detail Amount</b>
White Smary Copy Recycled Paper for Small Printers				10 E 2632 3000 00 300 000000		100.0000%		1,856.00
<b>Total for Murnane Paper Company:</b>							<b>1,856.00</b>	
Murphy, Kevin R		Cellphone Reimb	DFC	March Cellphone Reimbursement	03/27/2024	9100002335	100.00	
<b>Detail Description</b>				<b>Detail Account</b>		<b>Accounting Percent</b>		<b>Detail Amount</b>
Cell Phone Reimbursement				20 E 2540 3400 00 300 000001		100.0000%		100.00
<b>Total for Murphy, Kevin R:</b>							<b>100.00</b>	
Music Theatre International		1091912	DFC	Disney's Beauty & the Beast	01/03/2024	089101	50.00	
<b>Detail Description</b>				<b>Detail Account</b>		<b>Accounting Percent</b>		<b>Detail Amount</b>
Disney Beauty & the Beast				10 E 1500 3000 70 300 000000		100.0000%		50.00
<b>Total for Music Theatre International:</b>							<b>50.00</b>	
Napa Auto Parts		145459	DFC	Supplies	03/27/2024	089102	42.98	
<b>Detail Description</b>				<b>Detail Account</b>		<b>Accounting Percent</b>		<b>Detail Amount</b>
Lamp				40 E 2552 4100 00 300 000001		100.0000%		42.98
Napa Auto Parts		145726	DFC	Supplies	04/03/2024	089102	625.78	
<b>Detail Description</b>				<b>Detail Account</b>		<b>Accounting Percent</b>		<b>Detail Amount</b>
Supplies				40 E 2552 4100 00 300 000001		100.0000%		625.78
<b>Total for Napa Auto Parts:</b>							<b>668.76</b>	
Naperville Psychiatric Ventures-Linden Oaks Tutoring Service		111-606	DFC	Tuition	03/31/2024	089103	873.60	
<b>Detail Description</b>				<b>Detail Account</b>		<b>Accounting Percent</b>		<b>Detail Amount</b>
Tuition				10 E 1200 6700 00 300 000002		100.0000%		873.60

## Invoice Listing

COUNTY OF GRUNDY SCHOOL DIST 111

Vendor	PO Number	Invoice Number	Batch	Description	Invoice Date	Check Number	Net Amount
Naperville Psychiatric Ventures-Linden Oaks Tutoring Service		111-607	DFC	Tutoring	03/31/2024	089103	312.00
<b>Detail Description</b>		<b>Detail Account</b>		<b>Accounting Percent</b>		<b>Detail Amount</b>	
Tuition		10 E 1200 6700 00 300 000002		100.0000%		312.00	
<b>Total for Naperville Psychiatric Ventures-Linden Oaks Tutoring Service:</b>							<b>1,185.60</b>
Nelco		9394383	DFC	Payroll Checks	03/22/2024	089104	271.10
<b>Detail Description</b>		<b>Detail Account</b>		<b>Accounting Percent</b>		<b>Detail Amount</b>	
Payroll Checks		10 E 2525 4100 00 300 000000		100.0000%		271.10	
<b>Total for Nelco:</b>							<b>271.10</b>
Nicor Gas		2785696 4/24	DFC	Services 3/4-4/2	04/02/2024	089105	356.84
<b>Detail Description</b>		<b>Detail Account</b>		<b>Accounting Percent</b>		<b>Detail Amount</b>	
Services 3/4-4/2		20 E 2540 4650 00 300 000000		100.0000%		356.84	
Nicor Gas		3891395 4/24	DFC	Services 3/1-4/1	04/02/2024	089105	1,358.84
<b>Detail Description</b>		<b>Detail Account</b>		<b>Accounting Percent</b>		<b>Detail Amount</b>	
Services 3/1-4/1		20 E 2540 4650 00 302 000000		100.0000%		1,358.84	
Nicor Gas		41874919 4/24	DFC	Services 3/4-4/2	04/03/2024	089105	59.48
<b>Detail Description</b>		<b>Detail Account</b>		<b>Accounting Percent</b>		<b>Detail Amount</b>	
Services 3/25-4/3		20 E 2540 3400 00 301 000000		100.0000%		59.48	
Nicor Gas		5139697 4/24	DFC	Services 3/1-4/1	04/02/2024	089105	2,032.31
<b>Detail Description</b>		<b>Detail Account</b>		<b>Accounting Percent</b>		<b>Detail Amount</b>	
Services 3/1-4/1		20 E 2540 4650 00 300 000000		100.0000%		2,032.31	
Nicor Gas		5302239 4/24	DFC	Services 3/4-4/2	04/02/2024	089105	359.86
<b>Detail Description</b>		<b>Detail Account</b>		<b>Accounting Percent</b>		<b>Detail Amount</b>	
Services 3/4-4/2		20 E 2540 4650 00 303 000000		100.0000%		359.86	
Nicor Gas		5419427 4/24	DFC	Service 3/4-4/2	04/03/2024	089105	672.23
<b>Detail Description</b>		<b>Detail Account</b>		<b>Accounting Percent</b>		<b>Detail Amount</b>	
Services 3/4-4/2		20 E 2540 4650 00 300 000000		100.0000%		672.23	
<b>Total for Nicor Gas:</b>							<b>4,839.56</b>
Norman, Kathryn A		Cellphone Reimb	DFC	Jan-March Cellphone Reimb	03/29/2024	089106	300.00
<b>Detail Description</b>		<b>Detail Account</b>		<b>Accounting Percent</b>		<b>Detail Amount</b>	
Phone January, February, March		20 E 2540 3400 00 300 000001		100.0000%		300.00	
<b>Total for Norman, Kathryn A:</b>							<b>300.00</b>

## Invoice Listing

COUNTY OF GRUNDY SCHOOL DIST 111

Vendor	PO Number	Invoice Number	Batch	Description	Invoice Date	Check Number	Net Amount
North American Safety, Inc.		INV86568	DFC	Supplies	03/28/2024	089107	221.00
<b>Detail Description</b>		<b>Detail Account</b>		<b>Accounting Percent</b>		<b>Detail Amount</b>	
Disposable Gloves		20 E 2540 4100 00 300 000000		100.0000%		221.00	
<b>Total for North American Safety, Inc.:</b>							<b>221.00</b>
Parkland Preparatory Academy Plainfield	6010		DFC	Tuition	03/22/2024	089108	3,644.16
<b>Detail Description</b>		<b>Detail Account</b>		<b>Accounting Percent</b>		<b>Detail Amount</b>	
Tuition		10 E 1912 6700 00 300 000000		100.0000%		3,644.16	
<b>Total for Parkland Preparatory Academy Plainfield:</b>							<b>3,644.16</b>
Petrarca, Gleason, Boyle & Izzo, Inc	34917		DFC	January Services	01/31/2024	089109	3,150.00
<b>Detail Description</b>		<b>Detail Account</b>		<b>Accounting Percent</b>		<b>Detail Amount</b>	
January Services		80 E 2310 3180 00 300 000000		100.0000%		3,150.00	
Petrarca, Gleason, Boyle & Izzo, Inc	35096		DFC	February Fees	02/29/2024	089109	200.00
<b>Detail Description</b>		<b>Detail Account</b>		<b>Accounting Percent</b>		<b>Detail Amount</b>	
February Fees		80 E 2310 3180 00 300 000000		100.0000%		200.00	
Petrarca, Gleason, Boyle & Izzo, Inc	35097		DFC	February Services	02/29/2024	089109	2,375.00
<b>Detail Description</b>		<b>Detail Account</b>		<b>Accounting Percent</b>		<b>Detail Amount</b>	
February Services		80 E 2310 3180 00 300 000000		100.0000%		2,375.00	
<b>Total for Petrarca, Gleason, Boyle &amp; Izzo, Inc:</b>							<b>5,725.00</b>
Pioneer Athletics	INV916680		DFC	Gameline Universal Aerosol	03/04/2024	089110	508.11
<b>Detail Description</b>		<b>Detail Account</b>		<b>Accounting Percent</b>		<b>Detail Amount</b>	
Gameline Universal Aerosol		20 E 2540 4100 00 300 000001		100.0000%		508.11	
<b>Total for Pioneer Athletics:</b>							<b>508.11</b>
PJMP LLC	#P-132570		DFC	Bus 132 Tow	03/18/2024	089111	300.00
<b>Detail Description</b>		<b>Detail Account</b>		<b>Accounting Percent</b>		<b>Detail Amount</b>	
Bus 132 Tow		40 E 2554 3230 00 300 000000		100.0000%		300.00	
<b>Total for PJMP LLC:</b>							<b>300.00</b>

## Invoice Listing

COUNTY OF GRUNDY SCHOOL DIST 111

Vendor	PO Number	Invoice Number	Batch	Description	Invoice Date	Check Number	Net Amount
Poms Tire Service		690133914	DFC	Bus 55 Repairs	03/15/2024	9100002336	1,887.44
<b>Detail Description</b>		<b>Detail Account</b>		<b>Accounting Percent</b>		<b>Detail Amount</b>	
Bus 55 Repairs		40 E 2554 3230 00 300 000000		100.0000%		1,887.44	
<b>Total for Poms Tire Service:</b>							<b>1,887.44</b>
Pro-Motion Physical Therapy LLC	103		DFC	3rd Quarter Athletic Training Services	03/27/2024	089112	3,048.80
<b>Detail Description</b>		<b>Detail Account</b>		<b>Accounting Percent</b>		<b>Detail Amount</b>	
3rd Quarter Athletic Training Services		10 E 1417 3900 00 300 000000		100.0000%		3,048.80	
<b>Total for Pro-Motion Physical Therapy LLC:</b>							<b>3,048.80</b>
Proven Business Systems		1160961	DFC	Printer Maintenance	03/25/2024	089113	5,288.88
<b>Detail Description</b>		<b>Detail Account</b>		<b>Accounting Percent</b>		<b>Detail Amount</b>	
Printer Maintenance		10 E 2632 3000 00 300 000000		100.0000%		5,288.88	
<b>Total for Proven Business Systems:</b>							<b>5,288.88</b>
Quadient Finance		7900044075299481 3/24	DFC	Postage	03/13/2024	089114	2,000.00
<b>Detail Description</b>		<b>Detail Account</b>		<b>Accounting Percent</b>		<b>Detail Amount</b>	
Postage		10 E 2410 3400 00 300 000000		100.0000%		2,000.00	
<b>Total for Quadient Finance:</b>							<b>2,000.00</b>
Quadient Leasing USA, Inc., Dept. 3682		Q1240124	DFC	Postage Machine Lease	03/10/2024	089115	767.67
<b>Detail Description</b>		<b>Detail Account</b>		<b>Accounting Percent</b>		<b>Detail Amount</b>	
Postage Machine Lease South Campus		10 E 2410 3400 00 300 000000		100.0000%		767.67	
Quadient Leasing USA, Inc., Dept. 3682		Q1240486	DFC	Postage meter lease	03/10/2024	089115	767.67
<b>Detail Description</b>		<b>Detail Account</b>		<b>Accounting Percent</b>		<b>Detail Amount</b>	
Lease postage meter Central		10 E 2410 3400 00 300 000000		100.0000%		767.67	
<b>Total for Quadient Leasing USA, Inc., Dept. 3682:</b>							<b>1,535.34</b>
Quest Food		IN122921	DFC	March Food Service	03/31/2024	9100002337	117,652.68
<b>Detail Description</b>		<b>Detail Account</b>		<b>Accounting Percent</b>		<b>Detail Amount</b>	
March Reimbursable Food		10 E 2560 3150 00 300 000000		3.5667%		4,196.28	
March Reimbursable Food		10 E 2560 3000 00 300 000000		96.4333%		113,456.40	
<b>Total for Quest Food:</b>							<b>117,652.68</b>

## Invoice Listing

COUNTY OF GRUNDY SCHOOL DIST 111

Vendor	PO Number	Invoice Number	Batch	Description	Invoice Date	Check Number	Net Amount
Rayner & Rinn-Scott Inc.	1092400089	58471	DFC	Hardwood order for woods	03/21/2024	089116	948.00
<b>Detail Description</b>				<b>Detail Account</b>		<b>Accounting Percent</b>	<b>Detail Amount</b>
HPO44001 4/4 RWL FAS 1F&BTR POPLAR RGH KD HOM 15/16" & SLR1E 10' Lengths				10 E 1400 4100 10 300 000001		100.0000%	460.00
HPO44004 4/4 8" & WDR FAS 1F&BTR POPLAR RGH KD HOM 15/16" & SLR1E 10' LENGTHS				10 E 1400 4100 10 300 000001		100.0000%	488.00
Rayner & Rinn-Scott Inc.	1092400089	58472	DFC	Hardwood order for woods	03/21/2024	089116	726.00
<b>Detail Description</b>				<b>Detail Account</b>		<b>Accounting Percent</b>	<b>Detail Amount</b>
HCH44001 4/4 RWL SEL&BTR CHERRY RGH KD 90/70 HOM 15/16" & SLR1E				10 E 1400 4100 10 300 000001		100.0000%	365.00
HHI44001 4/4 RWL SEL&BTR (CALICO) HICKORY RGH KD HOM 15/16" & SLR1E RW x 10' LENGTHS				10 E 1400 4100 10 300 000001		100.0000%	361.00
<b>Total for Rayner &amp; Rinn-Scott Inc.:</b>							<b>1,674.00</b>
Realityworks Inc	1092400068	55081	DFC	Babies and accessories for Child Development class.	03/25/2024	089117	2,933.40
<b>Detail Description</b>				<b>Detail Account</b>		<b>Accounting Percent</b>	<b>Detail Amount</b>
RealCare Baby with 5 Year Warranty, Accessories and Single Storage Case				10 E 1420 5400 09 300 000000		100.0000%	2,798.00
Shipping				10 E 1420 5400 09 300 000000		100.0000%	140.40
<b>Total for Realityworks Inc:</b>							<b>2,938.40</b>
Richland School District 88A		WICLO202404	DFC	4/10 Will County Organization Meeting	04/10/2024	089118	25.00
<b>Detail Description</b>				<b>Detail Account</b>		<b>Accounting Percent</b>	<b>Detail Amount</b>
4/10 Will County Organization Meeting				10 E 2510 6400 00 300 000000		100.0000%	25.00
<b>Total for Richland School District 88A:</b>							<b>25.00</b>
Rival5 Technologies	0002400117	22722	DFC	Lockdown System	04/01/2024	9100002338	7,749.98
<b>Detail Description</b>				<b>Detail Account</b>		<b>Accounting Percent</b>	<b>Detail Amount</b>
Lockdown system				80 E 2546 5400 00 300 000000		100.0000%	7,749.98
Rival5 Technologies		22642	DFC	Phones	04/01/2024	9100002339	5,361.80
<b>Detail Description</b>				<b>Detail Account</b>		<b>Accounting Percent</b>	<b>Detail Amount</b>
Phones				20 E 2540 3400 00 300 000001		100.0000%	5,361.80

## Invoice Listing

COUNTY OF GRUNDY SCHOOL DIST 111

Vendor	PO Number	Invoice Number	Batch	Description	Invoice Date	Check Number	Net Amount	
Rival5 Technologies		22643	DFC	Phones	04/01/2024	9100002340	215.04	
<b>Detail Description</b>				<b>Detail Account</b>		<b>Accounting Percent</b>		<b>Detail Amount</b>
Phones				20 E 2540 3400 00 300 000001		100.0000%		215.04
<b>Total for Rival5 Technologies:</b>							<b>13,326.82</b>	
Roberts Snowplowing		2024004	DFC	Central Campus Salt Spreading	02/29/2024	089119	650.00	
<b>Detail Description</b>				<b>Detail Account</b>		<b>Accounting Percent</b>		<b>Detail Amount</b>
Central Campus Salt Spreading				20 E 2540 3000 00 300 000004		100.0000%		650.00
Roberts Snowplowing		2024005	DFC	South Campus Salt Spreading	02/29/2024	089119	585.00	
<b>Detail Description</b>				<b>Detail Account</b>		<b>Accounting Percent</b>		<b>Detail Amount</b>
South Campus Salt Spreading				20 E 2540 3000 00 302 000002		100.0000%		585.00
<b>Total for Roberts Snowplowing:</b>							<b>1,235.00</b>	
Rock Valley Publishing		8221	DFC	Newspaper	03/30/2024	9100002341	749.00	
<b>Detail Description</b>				<b>Detail Account</b>		<b>Accounting Percent</b>		<b>Detail Amount</b>
Newspaper				10 E 1500 3000 70 300 000003		100.0000%		749.00
<b>Total for Rock Valley Publishing:</b>							<b>749.00</b>	
Rodgers Silk Screening Etc.		032224	DFC	Shirts	03/22/2024	089120	728.50	
<b>Detail Description</b>				<b>Detail Account</b>		<b>Accounting Percent</b>		<b>Detail Amount</b>
Shirts				40 E 2552 4100 00 300 000000		100.0000%		728.50
<b>Total for Rodgers Silk Screening Etc.:</b>							<b>728.50</b>	
Rogue Fitness	2032400130	12417660	DFC	Football Westside Scout Hyper Handle Extension Kit (Hardware Included) Westside Scout Hyper v1.3	03/19/2024	9500000208	2,563.05	
<b>Detail Description</b>				<b>Detail Account</b>		<b>Accounting Percent</b>		<b>Detail Amount</b>
Westside Scout Hyper Handle Extension Kit (Hardware Included)				11 E 1999 4100 30 300 910014		100.0000%		51.30
Westside Scout Hyper v1.3				11 E 1999 4100 30 300 910014		100.0000%		2,251.50
Shipping				11 E 1999 4100 30 300 910014		100.0000%		260.25
<b>Total for Rogue Fitness:</b>							<b>2,563.05</b>	
S.E.A.L. South		8458	DFC	Tuition	03/22/2024	089121	22,798.40	
<b>Detail Description</b>				<b>Detail Account</b>		<b>Accounting Percent</b>		<b>Detail Amount</b>
Tuition				10 E 1912 6700 00 300 000000		100.0000%		22,798.40

## Invoice Listing

COUNTY OF GRUNDY SCHOOL DIST 111

Vendor	PO Number	Invoice Number	Batch	Description	Invoice Date	Check Number	Net Amount	
S.E.A.L. South		8466	DFC	Tuition	03/22/2024	089121	8,834.38	
<b>Detail Description</b>				<b>Detail Account</b>		<b>Accounting Percent</b>		<b>Detail Amount</b>
Tuition				10 E 1912 6700 00 300 000000		100.0000%		8,834.38
<b>Total for S.E.A.L. South:</b>							<b>31,632.78</b>	
Salclay Truck and Trailer Repair		10202	DFC	State Inspections	10/03/2023	089122	357.00	
<b>Detail Description</b>				<b>Detail Account</b>		<b>Accounting Percent</b>		<b>Detail Amount</b>
State Inspections: 42, 133, 61, 57, 128, 71, 132				40 E 2554 3390 00 300 000000		100.0000%		357.00
Salclay Truck and Trailer Repair		11166	DFC	State Inspections	03/29/2024	089122	561.00	
<b>Detail Description</b>				<b>Detail Account</b>		<b>Accounting Percent</b>		<b>Detail Amount</b>
State Inspections				40 E 2554 3390 00 300 000000		100.0000%		561.00
<b>Total for Salclay Truck and Trailer Repair:</b>							<b>918.00</b>	
Salem Press		187641	DFC	Books for Central Campus	03/27/2024	089123	130.00	
<b>Detail Description</b>				<b>Detail Account</b>		<b>Accounting Percent</b>		<b>Detail Amount</b>
Books for Central				10 E 2222 4300 00 300 000000		100.0000%		130.00
Salem Press	1172400047	188142	DFC	Book for Central Campus	03/22/2024	089123	130.00	
<b>Detail Description</b>				<b>Detail Account</b>		<b>Accounting Percent</b>		<b>Detail Amount</b>
Book for Central Campus				10 E 2222 4300 00 300 000000		100.0000%		130.00
<b>Total for Salem Press:</b>							<b>260.00</b>	
Sanchez-Lyons, Isabel		2024 Jr High Play	DFC	Jr High Play 4/2-4/6	04/06/2024	089124	182.00	
<b>Detail Description</b>				<b>Detail Account</b>		<b>Accounting Percent</b>		<b>Detail Amount</b>
Jr High Play 4/2-4/6				10 E 1500 1300 70 300 000003		100.0000%		182.00
<b>Total for Sanchez-Lyons, Isabel:</b>							<b>182.00</b>	
Schneider Electric		0001011296	DFC	Repair AH6 Supply Fan	03/28/2024	089125	530.00	
<b>Detail Description</b>				<b>Detail Account</b>		<b>Accounting Percent</b>		<b>Detail Amount</b>
Repair AH6 Supply Fan				20 E 2540 3230 00 302 000001		100.0000%		530.00
Schneider Electric		0001011301	DFC	Comm Issue	03/28/2024	089125	1,945.00	
<b>Detail Description</b>				<b>Detail Account</b>		<b>Accounting Percent</b>		<b>Detail Amount</b>
Comm Issue				20 E 2540 3230 00 302 000001		100.0000%		1,945.00
<b>Total for Schneider Electric:</b>							<b>2,475.00</b>	

## Invoice Listing

COUNTY OF GRUNDY SCHOOL DIST 111

Vendor	PO Number	Invoice Number	Batch	Description	Invoice Date	Check Number	Net Amount		
Sentinel Technologies	0002400118	INV6797	DFC	Internet Access Points/Switches	04/03/2024	089126	36,846.14		
<b>Detail Description</b>				<b>Detail Account</b>		<b>Accounting Percent</b>		<b>Detail Amount</b>	
Internet Access Points & Switches for New Building				80 E 2546 4100 00 300 000000		100.0000%		36,846.14	
<b>Total for Sentinel Technologies:</b>							<b>36,846.14</b>		
Shanholtzer, Allison		2024 Musical Chaperone	DFC	2024 Musical Chaperone	03/18/2024	089127	91.00		
<b>Detail Description</b>				<b>Detail Account</b>		<b>Accounting Percent</b>		<b>Detail Amount</b>	
2024 Musical Chaperone				10 E 1500 1300 70 300 000003		100.0000%		91.00	
<b>Total for Shanholtzer, Allison:</b>							<b>91.00</b>		
Shaw Media		032410057672	DFC	March Advertising	03/31/2024	9100002342	72.92		
<b>Detail Description</b>				<b>Detail Account</b>		<b>Accounting Percent</b>		<b>Detail Amount</b>	
March Advertising				10 E 2310 4100 00 300 000000		100.0000%		72.92	
<b>Total for Shaw Media:</b>							<b>72.92</b>		
SHI International Corp	1022400105	B18136564	DFC	Battery Backup Replacement for Football Press Box.	03/08/2024	089128	112.20		
<b>Detail Description</b>				<b>Detail Account</b>		<b>Accounting Percent</b>		<b>Detail Amount</b>	
Tripp Lite 1U UPS Replacement Battery Cartridge				10 E 2225 4100 00 300 000000		100.0000%		112.20	
<b>Total for SHI International Corp:</b>							<b>112.20</b>		
Shorewood Home & Auto		01-403995	DFC	Tire for gator	03/15/2024	9100002343	683.40		
<b>Detail Description</b>				<b>Detail Account</b>		<b>Accounting Percent</b>		<b>Detail Amount</b>	
Tires for Gator				20 E 2540 4100 00 300 000001		100.0000%		683.40	
<b>Total for Shorewood Home &amp; Auto:</b>							<b>759.71</b>		
Shorewood Home & Auto		01-404034	DFC	Supplies	03/15/2024	9100002343	76.31		
<b>Detail Description</b>				<b>Detail Account</b>		<b>Accounting Percent</b>		<b>Detail Amount</b>	
Supplies				20 E 2540 4100 00 300 000001		100.0000%		76.31	
<b>Total for Shorewood Home &amp; Auto:</b>							<b>759.71</b>		
Skwarczynski, Andrew		2024 Jr High Play	DFC	Jr High Play 4/2-4/6	04/06/2024	089129	182.00		
<b>Detail Description</b>				<b>Detail Account</b>		<b>Accounting Percent</b>		<b>Detail Amount</b>	
Jr High Play 4/2-4/6				10 E 1500 1300 70 300 000003		100.0000%		182.00	
<b>Total for Skwarczynski, Andrew:</b>							<b>182.00</b>		
Smith, Glenda R		Play Reimb	DFC	Play Reimb	04/01/2024	9100002344	633.29		
<b>Detail Description</b>				<b>Detail Account</b>		<b>Accounting Percent</b>		<b>Detail Amount</b>	
Play Reimb				10 E 1500 4100 70 300 000004		100.0000%		633.29	
<b>Total for Smith, Glenda R:</b>							<b>633.29</b>		

## Invoice Listing

COUNTY OF GRUNDY SCHOOL DIST 111

Vendor	PO Number	Invoice Number	Batch	Description	Invoice Date	Check Number	Net Amount
Soliman, Jamie L		March Cellphone Reimb	DFC	March Cellphone Reimb	03/27/2024	9100002345	100.00
<b>Detail Description</b>		<b>Detail Account</b>		<b>Accounting Percent</b>		<b>Detail Amount</b>	
Cell phone - March		20 E 2540 3400 00 300 000001		100.0000%		100.00	
<b>Total for Soliman, Jamie L:</b>							<b>100.00</b>
Sports Huddle	90563		DFC	Red Out Shirts	01/12/2024	23602	710.00
<b>Detail Description</b>		<b>Detail Account</b>		<b>Accounting Percent</b>		<b>Detail Amount</b>	
Red Out Shirts		11 E 1999 4100 30 300 910005		100.0000%		710.00	
<b>Total for Sports Huddle:</b>							<b>710.00</b>
Sublime Wear USA	317563		DFC	Apparel	04/08/2024	23603	73.99
<b>Detail Description</b>		<b>Detail Account</b>		<b>Accounting Percent</b>		<b>Detail Amount</b>	
Apparel		11 E 1999 4100 70 300 900032		100.0000%		73.99	
<b>Total for Sublime Wear USA:</b>							<b>73.99</b>
Ten Briscoes Real Estate Group	1009		DFC	April Rent	04/01/2024	9100002346	1,827.00
<b>Detail Description</b>		<b>Detail Account</b>		<b>Accounting Percent</b>		<b>Detail Amount</b>	
April Rent		20 E 2540 3200 00 301 000000		100.0000%		1,827.00	
<b>Total for Ten Briscoes Real Estate Group:</b>							<b>1,827.00</b>
Thomson Reuters - West	849973766		DFC	March Monthly Software	04/01/2024	089130	461.42
<b>Detail Description</b>		<b>Detail Account</b>		<b>Accounting Percent</b>		<b>Detail Amount</b>	
March Monthly Software		10 E 2125 3000 00 302 000000		100.0000%		461.42	
<b>Total for Thomson Reuters - West:</b>							<b>461.42</b>
Tremco Roofing	97509372		DFC	Patch & Repair Roof	03/04/2024	089131	1,490.00
<b>Detail Description</b>		<b>Detail Account</b>		<b>Accounting Percent</b>		<b>Detail Amount</b>	
Patch & Repair Roof		20 E 2540 3230 00 302 000000		100.0000%		1,490.00	
<b>Total for Tremco Roofing:</b>							<b>8,890.00</b>
Tremco Roofing	97538535		DFC	Infrared Diagnostics	03/26/2024	089131	7,400.00
<b>Detail Description</b>		<b>Detail Account</b>		<b>Accounting Percent</b>		<b>Detail Amount</b>	
Infrared Diagnostics		60 E 2535 3230 00 000 000000		100.0000%		7,400.00	
<b>Total for Tremco Roofing:</b>							<b>8,890.00</b>
Tri-K Inc	123702		DFC	Supplies	02/27/2024	089132	1,927.40
<b>Detail Description</b>		<b>Detail Account</b>		<b>Accounting Percent</b>		<b>Detail Amount</b>	
Supplies		20 E 2540 4100 00 300 000000		100.0000%		1,927.40	

## Invoice Listing

COUNTY OF GRUNDY SCHOOL DIST 111

Vendor	PO Number	Invoice Number	Batch	Description	Invoice Date	Check Number	Net Amount
Tri-K Inc		123737	DFC	Supplies	03/04/2024	089132	787.00
<b>Detail Description</b>				<b>Detail Account</b>		<b>Accounting Percent</b>	<b>Detail Amount</b>
Supplies				20 E 2540 4100 00 300 000000		100.0000%	787.00
Tri-K Inc		123793	DFC	Supplies	03/12/2024	089132	1,717.60
<b>Detail Description</b>				<b>Detail Account</b>		<b>Accounting Percent</b>	<b>Detail Amount</b>
Supplies				20 E 2540 4100 00 300 000000		100.0000%	1,717.60
Tri-K Inc		123860	DFC	Supplies	03/20/2024	089132	1,710.30
<b>Detail Description</b>				<b>Detail Account</b>		<b>Accounting Percent</b>	<b>Detail Amount</b>
Supplies				20 E 2540 4100 00 300 000000		100.0000%	1,710.30
<b>Total for Tri-K Inc:</b>							<b>6,142.30</b>
Ultimate Mats	0002400087	INV4235	DFC	Mats	01/23/2024	089133	6,132.00
<b>Detail Description</b>				<b>Detail Account</b>		<b>Accounting Percent</b>	<b>Detail Amount</b>
SBCLEM 610 - Approved for quantity 11-25 : Super Berber Custom Logo Entrance Mat 6ftx10ft				20 E 2540 4100 00 302 000000		100.0000%	6,132.00
<b>Total for Ultimate Mats:</b>							<b>6,132.00</b>
Umb Bank	MIN2		DFC	MIN2 Interest	03/01/2024	9100002347	153,900.00
<b>Detail Description</b>				<b>Detail Account</b>		<b>Accounting Percent</b>	<b>Detail Amount</b>
MIN 2 Interest				30 E 5140 6210 00 300 000008		100.0000%	153,900.00
<b>Total for Umb Bank:</b>							<b>153,900.00</b>
United Laboratories		INV403524	DFC	Supplies	03/22/2024	9100002348	1,142.87
<b>Detail Description</b>				<b>Detail Account</b>		<b>Accounting Percent</b>	<b>Detail Amount</b>
Supplies				20 E 2540 4100 00 300 000000		100.0000%	1,142.87
<b>Total for United Laboratories:</b>							<b>1,142.87</b>
UNO Volleyball Club	2032400143	2024 Uno Summer League	DFC	Girls Volleyball Summer League Registration	03/19/2024	23604	480.00
<b>Detail Description</b>				<b>Detail Account</b>		<b>Accounting Percent</b>	<b>Detail Amount</b>
Girls Volleyball Summer League Registration				11 E 1999 4100 30 300 910022		100.0000%	480.00
<b>Total for UNO Volleyball Club:</b>							<b>480.00</b>
Us Bank		7263645	DFC	Bond Series 2014 Fees	03/25/2024	089134	550.00
<b>Detail Description</b>				<b>Detail Account</b>		<b>Accounting Percent</b>	<b>Detail Amount</b>
Bond Series 2014 Fees				30 E 5900 3900 00 300 000000		100.0000%	550.00

## Invoice Listing

COUNTY OF GRUNDY SCHOOL DIST 111

Vendor	PO Number	Invoice Number	Batch	Description	Invoice Date	Check Number	Net Amount
Us Bank		7263712	DFC	Bond Series 2016B Fees	03/25/2024	089134	550.00
<b>Detail Description</b>		<b>Detail Account</b>		<b>Accounting Percent</b>		<b>Detail Amount</b>	
Bond Series 2016B Fees		30 E 5900 3900 00 300 000000		100.0000%		550.00	
						<b>Total for Us Bank:</b>	<b>1,100.00</b>
Us Bank Operations Center		2532589	DFC	School Refunding Bond Series 2014, 2015B, & 2016B	03/11/2024	089135	1,887,700.00
<b>Detail Description</b>		<b>Detail Account</b>		<b>Accounting Percent</b>		<b>Detail Amount</b>	
School Refunding Bond Series 2014 Interest		30 E 5140 6210 00 300 000001		100.0000%		17,000.00	
Interest on Series 2015B		30 E 5140 6210 00 300 000003		100.0000%		182,600.00	
Principal and Interest on Bond 2016B		30 E 5300 6110 00 000 000012		93.5964%		1,580,000.00	
Principal and Interest on Bond 2016B		30 E 5140 6210 00 300 000005		6.4036%		108,100.00	
						<b>Total for Us Bank Operations Center:</b>	<b>1,887,700.00</b>
Verizon Wireless		9960578245	DFC	Services 3/2-4/1	04/01/2024	089136	504.34
<b>Detail Description</b>		<b>Detail Account</b>		<b>Accounting Percent</b>		<b>Detail Amount</b>	
Services 3/2-4/1		20 E 2540 3400 00 300 000001		100.0000%		504.34	
						<b>Total for Verizon Wireless:</b>	<b>504.34</b>
Vertical Endeavors - Glendale Heights		VEG030524jc1	DFC	Outdoor Ed Fieldtrip	03/05/2024	23586	2,680.00
<b>Detail Description</b>		<b>Detail Account</b>		<b>Accounting Percent</b>		<b>Detail Amount</b>	
Outdoor Ed Fieldtrip		11 E 1999 4100 30 300 910024		100.0000%		2,680.00	
						<b>Total for Vertical Endeavors - Glendale Heights:</b>	<b>2,680.00</b>

## Invoice Listing

COUNTY OF GRUNDY SCHOOL DIST 111

Vendor	PO Number	Invoice Number	Batch	Description	Invoice Date	Check Number	Net Amount
Vex Robotics	1092400073	715391	DFC	Robotics parts	01/26/2024	089137	791.83
				<b>Detail Description</b>			<b>Detail Account</b>
							<b>Accounting Percent</b>
							<b>Detail Amount</b>
				276-4812 V5 Robot Battery Charger			11.99
				276-4811 V5 Robot Battery Li-Ion 1100mAh			72.49
				276-6020 V5 Battery Clip (4-Pack)			11.58
				276-8354 VRC Over Under Full Game & Field Element Kit			574.99
				275-1089 Synthetic Rubber Band #32 (20-pack)			3.19
				228-6633 Silicone Rubber Band #32 (10-pack)			5.99
				Shipping			111.60
				<b>Total for Vex Robotics:</b>			<b>791.83</b>
Village Of Channahon	2405		DFC	March Officer Cerovac	03/31/2024	089138	8,940.87
				<b>Detail Description</b>			<b>Detail Account</b>
							<b>Accounting Percent</b>
							<b>Detail Amount</b>
				Officer Cerovac			8,940.87
Village Of Channahon	2407		DFC	Traffic Light	03/01/2024	089138	103.50
				<b>Detail Description</b>			<b>Detail Account</b>
							<b>Accounting Percent</b>
							<b>Detail Amount</b>
				Traffic Light			103.50
Village Of Channahon	2408		DFC	Extra Duties	03/31/2024	089138	301.25
				<b>Detail Description</b>			<b>Detail Account</b>
							<b>Accounting Percent</b>
							<b>Detail Amount</b>
				Extra Duties			301.25
Village Of Channahon	Balance due 2384		DFC	Balance due on invoice 2384	02/29/2024	089138	89.00
				<b>Detail Description</b>			<b>Detail Account</b>
							<b>Accounting Percent</b>
							<b>Detail Amount</b>
				Balance due on invoice 2384			89.00
Village Of Channahon	EAMS-026655-0000-01		DFC	March Services	03/31/2024	089138	3,114.29
				<b>Detail Description</b>			<b>Detail Account</b>
							<b>Accounting Percent</b>
							<b>Detail Amount</b>
				March Services			3,114.29
				<b>Total for Village Of Channahon:</b>			<b>12,548.91</b>
Village Of Minooka	1-08000188-00 4/24		DFC	Services 2/20-3/19	04/01/2024	9100002349	325.43
				<b>Detail Description</b>			<b>Detail Account</b>
							<b>Accounting Percent</b>
							<b>Detail Amount</b>
				Services 2/20-3/19			325.43

## Invoice Listing

COUNTY OF GRUNDY SCHOOL DIST 111

Vendor	PO Number	Invoice Number	Batch	Description	Invoice Date	Check Number	Net Amount	
Village Of Minooka		12834	DFC	Engineering Reimbursement	04/04/2024	9100002349	259.75	
<b>Detail Description</b>				<b>Detail Account</b>		<b>Accounting Percent</b>		<b>Detail Amount</b>
Engineering Reimbursement				60 E 2533 3000 00 000 000000		100.0000%		259.75
Village Of Minooka		1-80000200-01 4/24	DFC	Services 2/29-3/31	04/01/2024	9100002349	33.63	
<b>Detail Description</b>				<b>Detail Account</b>		<b>Accounting Percent</b>		<b>Detail Amount</b>
Services 2/29-3/31				20 E 2540 3700 00 303 000000		100.0000%		33.63
Village Of Minooka		1-80000400-01 4/24	DFC	Services 2/20-3/19	04/01/2024	9100002349	94.25	
<b>Detail Description</b>				<b>Detail Account</b>		<b>Accounting Percent</b>		<b>Detail Amount</b>
Services 2/20-3/19				40 E 2550 3700 00 300 000000		100.0000%		94.25
<b>Total for Village Of Minooka:</b>							<b>713.06</b>	
Visual Image Photography Inc		13812	DFC	Senior Banners	03/19/2024	089139	2,540.00	
<b>Detail Description</b>				<b>Detail Account</b>		<b>Accounting Percent</b>		<b>Detail Amount</b>
Boys Tennis, Girls Track, Boys Track, Girls Soccer, Boys Volleyball, Softball, Baseball, Boys Lacrosse, Girls Lacrosse Senior Banners				10 E 1500 4100 30 300 000021		100.0000%		2,540.00
Visual Image Photography Inc		13889	DFC	Banner	04/02/2024	089139	<del>40.00</del>	
<b>Detail Description</b>				<b>Detail Account</b>		<b>Accounting Percent</b>		<b>Detail Amount</b>
Banner				10 E 1500 4100 30 300 000021		100.0000%		40.00
<b>Total for Visual Image Photography Inc:</b>							<b>2,580.00</b>	
Waste Management Of IL		66000242-2007-2	DFC	Services 3/1-3/15	03/18/2024	089140	757.92	
<b>Detail Description</b>				<b>Detail Account</b>		<b>Accounting Percent</b>		<b>Detail Amount</b>
Services 3/1-3/15				20 E 2540 3210 00 300 000000		100.0000%		757.92
Waste Management Of IL		6602278-2007-4	DFC	Services 4/1-4/30	04/03/2024	089140	4,441.25	
<b>Detail Description</b>				<b>Detail Account</b>		<b>Accounting Percent</b>		<b>Detail Amount</b>
Services 4/1-4/30				20 E 2540 3210 00 300 000000		100.0000%		4,441.25
Waste Management Of IL		6602304-2007-8	DFC	Services 4/1-4/30	04/03/2024	089140	416.95	
<b>Detail Description</b>				<b>Detail Account</b>		<b>Accounting Percent</b>		<b>Detail Amount</b>
Services 4/1/4/30				20 E 2540 3210 00 300 000000		100.0000%		416.95

## Invoice Listing

COUNTY OF GRUNDY SCHOOL DIST 111

Vendor	PO Number	Invoice Number	Batch	Description	Invoice Date	Check Number	Net Amount	
Waste Management Of IL		6603018-2007-3	DFC	Services 4/1-4/30	04/11/2024	089140	6,076.73	
<b>Detail Description</b>				<b>Detail Account</b>		<b>Accounting Percent</b>		<b>Detail Amount</b>
Services 4/1-4/30				20 E 2540 3210 00 302 000000		100.0000%		6,076.73
<b>Total for Waste Management Of IL:</b>							<b>11,692.85</b>	
Weldstar Company	1092400012	0002268549	DFC	Open PO	03/11/2024	9100002350	170.38	
<b>Detail Description</b>				<b>Detail Account</b>		<b>Accounting Percent</b>		<b>Detail Amount</b>
Open PO				10 E 1400 4100 10 300 000001		100.0000%		170.38
Weldstar Company	1092400012	0002272620	DFC	Open PO	03/24/2024	9100002350	211.41	
<b>Detail Description</b>				<b>Detail Account</b>		<b>Accounting Percent</b>		<b>Detail Amount</b>
Open PO				10 E 1400 4100 10 300 000001		100.0000%		211.41
<b>Total for Weldstar Company:</b>							<b>381.79</b>	
Wheaton Warrenville South High School	1032400568	2024 Tiger Boys Volleybal	DFC	Boys Volleyball Tiger Classic Invite Entry Fee	03/27/2024	089141	350.00	
<b>Detail Description</b>				<b>Detail Account</b>		<b>Accounting Percent</b>		<b>Detail Amount</b>
Boys Volleyball Tiger Classic Invite Entry Fee				10 E 1500 3900 30 300 000000		100.0000%		350.00
<b>Total for Wheaton Warrenville South High School:</b>							<b>350.00</b>	
Whitmore Ace Hardware		122026	DFC	Supplies	04/01/2024	23605	43.98	
<b>Detail Description</b>				<b>Detail Account</b>		<b>Accounting Percent</b>		<b>Detail Amount</b>
Winterguard Supplies				11 E 1999 4100 70 300 900051		100.0000%		43.98
Whitmore Ace Hardware		122027	DFC	Supplies	04/01/2024	23605	14.97	
<b>Detail Description</b>				<b>Detail Account</b>		<b>Accounting Percent</b>		<b>Detail Amount</b>
Supplies				11 E 1999 4100 70 300 900051		100.0000%		14.97
Whitmore Ace Hardware		121704	DFC	Supplies	02/29/2024	089142	32.57	
<b>Detail Description</b>				<b>Detail Account</b>		<b>Accounting Percent</b>		<b>Detail Amount</b>
Supplies				20 E 2540 4100 00 300 000000		100.0000%		32.57
Whitmore Ace Hardware		121816	DFC	Supplies	03/13/2024	089142	29.99	
<b>Detail Description</b>				<b>Detail Account</b>		<b>Accounting Percent</b>		<b>Detail Amount</b>
Supplies				20 E 2540 4100 00 302 000000		100.0000%		29.99
Whitmore Ace Hardware		121823	DFC	Supplies	03/13/2024	089142	117.87	
<b>Detail Description</b>				<b>Detail Account</b>		<b>Accounting Percent</b>		<b>Detail Amount</b>
Supplies				20 E 2540 4100 00 300 000000		100.0000%		117.87

## Invoice Listing

COUNTY OF GRUNDY SCHOOL DIST 111

Vendor	PO Number	Invoice Number	Batch	Description	Invoice Date	Check Number	Net Amount
Whitmore Ace Hardware		121867	DFC	Supplies	03/16/2024	089142	26.00
<b>Detail Description</b>		<b>Detail Account</b>		<b>Accounting Percent</b>		<b>Detail Amount</b>	
Supplies		20 E 2540 4100 00 300 000001		100.0000%		26.00	
Whitmore Ace Hardware		121915	DFC	Supplies	03/21/2024	089142	69.96
<b>Detail Description</b>		<b>Detail Account</b>		<b>Accounting Percent</b>		<b>Detail Amount</b>	
Supplies		20 E 2540 4100 00 300 000000		100.0000%		69.96	
Whitmore Ace Hardware		121998	DFC	Supplies	03/28/2024	089142	31.98
<b>Detail Description</b>		<b>Detail Account</b>		<b>Accounting Percent</b>		<b>Detail Amount</b>	
Supplies		20 E 2540 4100 00 300 000000		100.0000%		31.98	
Whitmore Ace Hardware		122033	DFC	Supplies	04/02/2024	089142	9.18
<b>Detail Description</b>		<b>Detail Account</b>		<b>Accounting Percent</b>		<b>Detail Amount</b>	
Supplies		20 E 2540 4100 00 302 000000		100.0000%		9.18	
Whitmore Ace Hardware		122098	DFC	Supplies	04/09/2024	089142	36.72
<b>Detail Description</b>		<b>Detail Account</b>		<b>Accounting Percent</b>		<b>Detail Amount</b>	
Keys		20 E 2540 4100 00 302 000000		100.0000%		36.72	
<b>Total for Whitmore Ace Hardware:</b>							<b>413.32</b>
Wren, Michelle		Reach Volleyball Team	DFC	Reach Volleyball Team	04/09/2024	089143	52.00
<b>Detail Description</b>		<b>Detail Account</b>		<b>Accounting Percent</b>		<b>Detail Amount</b>	
Reach Volleyball Team		10 E 1500 1300 30 300 000002		100.0000%		52.00	
<b>Total for Wren, Michelle:</b>							<b>52.00</b>

### REPORT

<b>Total Number of Batch Invoices:</b>	0	0.00
<b>Total Number of Open Invoices:</b>	0	0.00
<b>Total Number of History Invoices:</b>	562	3,721,061.78
<b>Total Number of Update in Progress Batch Invoices:</b>	0	0.00
<b>Total Number of Update in Progress Batch Reversal Invoices:</b>	0	0.00
<b>Total Number of Reversal History Invoices:</b>	0	0.00
<b>Total Number of Deleted History Invoices:</b>	0	0.00
<b>Total Number of Batch Reversal Invoices:</b>	0	0.00
<b>Total Number of Unsubmitted Invoices:</b>	0	0.00
<b>Total Number of Awaiting for Approval Invoices:</b>	0	0.00
<b>Total Invoices:</b>	<b>562</b>	<b>3,721,061.78</b>

## Payroll Summaries

Check Date: 3/1/2024 12:00:00 AM - 3/31/2024 12:00:00 AM

COUNTY OF GRUNDY SCHOOL DIST 111

Payroll Run	Pay Gross	Fed Gross	Fed Tax	State Gross	State Tax	SS Gross	SS Tax	Med Gross	Med Tax
3/15/24 - 03/15/2024	909,150.04	842,831.27	81,581.88	842,831.27	40,479.87	179,644.15	11,137.94	873,055.41	12,659.42
3/15/24 - 3/15/2024 Void Tammy	-33.14	-33.14	0.00	-33.14	0.00	-33.14	-2.05	-33.14	-0.48
3/15/24 - 3/15/2024 Reissue	33.14	33.14	0.00	33.14	0.00	33.14	2.05	33.14	0.48
3/29/24 - 03/29/2024 Payroll	918,116.29	851,761.28	81,997.88	851,761.28	40,818.64	180,773.30	11,207.97	880,221.66	12,763.23
<b>Totals:</b>	<b>1,827,266.33</b>	<b>1,694,592.55</b>	<b>163,579.76</b>	<b>1,694,592.55</b>	<b>81,298.51</b>	<b>360,417.45</b>	<b>22,345.91</b>	<b>1,753,277.07</b>	<b>25,422.65</b>

IMPREST

3/31/2024

	EDUCATION	BUILDING	BOND & INT	TRANSPORTATION	SS/IMRF	TORT	TOTAL
BEG BALANCE	8107.65	2603.04	0.00	3332.76	0.00	0.00	14043.45
Transfer	0.00	0.00		0.00			0.00
	0.00	0.00		0.00	0.00		0.00
DEPOSITS	0.00						0.00
	0.00						0.00
TOTAL RECEIPTS	0.00	0.00	0.00	0.00	0.00	0.00	0.00
DISBURSEMENTS	0.00			0.00			
26544	170	0.00		0.00			0.00
26545	1123.09	0.00		0.00			
26546	200	0.00		0.00			
26547	300	0.00		0.00			
26548	835						
26549	210			0.00			
26550	175.00						
26551	750.00						
	0.00						
	0.00						
	0.00						
	0.00						
TOTAL DISBURSEMENTS	3763.09	0.00	0.00	0.00	0.00	0.00	3763.09
ENDING BALANCE	4344.56	2603.04	0.00	3332.76	0.00	0.00	10280.36

145

BANK BALANCE	15663.74		LEDGER BALANCE	10280.36
OUTSTANDING CHECKS	4250.10		OUTSTANDING CHECKS	4250.10
DIFFERENCE	1133.28		VOID	
REGISTER BALANCE	10280.36	BALANCE	DIFFERENCE	1133.28
			BANK BALANCE	15663.74
			BALANCE	

0.00

## Balance Sheet Detail by Fund

March	2023-2024	COUNTY OF GRUNDY SCHOOL DIST 111			
Account	Account Description	Beginning Balance	Debit	Credit	Ending Balance
<b>11 - Activity Fund</b>					
A - Asset					
11 A 1260 0000 00 000 000000	CASH-ACTIVITIES	508,880.24	61,334.51	34,394.89	535,819.86
11 A 1261 0000 00 000 000000	COADY SCHOLARSHIP	269,612.31	1,202.31	0.00	270,814.62
<b>Totals for: 11 A - Asset</b>		<b>778,492.55</b>	<b>62,536.82</b>	<b>34,394.89</b>	<b>806,634.48</b>
L - Liability					
11 L 4310 0000 00 000 000000	AP Liability	0.00	34,420.63	34,420.63	0.00
<b>Totals for: 11 L - Liability</b>		<b>0.00</b>	<b>34,420.63</b>	<b>34,420.63</b>	<b>0.00</b>
Q - Equity					
11 Q 7130 0000 00 000 000000	FUND BALANCE	(51,326.86)	7,452.84	30,465.81	(74,339.83)
11 Q 7131 0000 00 000 000000	FUND BALANCE	51,325.86	30,465.81	7,452.84	74,338.83
11 Q 7150 0000 01 000 900000	COADY SCHOLARSHIP	(269,612.31)	0.00	1,202.31	(270,814.62)
11 Q 7150 0000 30 300 910001	SPORTS - ATHLETIC HALL OF FAME	(5,460.86)	0.00	0.00	(5,460.86)
11 Q 7150 0000 30 300 910002	SPORTS - ATHLETIC POP	(4,767.20)	90.05	120.92	(4,798.07)
11 Q 7150 0000 30 300 910003	SPORTS - ATHLETIC TRAINING	(372.45)	0.00	0.00	(372.45)
11 Q 7150 0000 30 300 910004	SPORTS - BASEBALL	(26,132.29)	71.92	79.00	(26,139.37)
11 Q 7150 0000 30 300 910005	SPORTS - BOYS BASKETBALL	(16,704.06)	1,845.98	0.00	(14,858.08)
11 Q 7150 0000 30 300 910006	SPORTS - BOYS BOWLING	298.68	640.00	0.00	938.68
11 Q 7150 0000 30 300 910007	SPORTS - BOYS GOLF	(2,363.68)	0.00	0.00	(2,363.68)
11 Q 7150 0000 30 300 910008	SPORTS - BOYS SOCCER	(13,210.35)	0.00	0.00	(13,210.35)
11 Q 7150 0000 30 300 910009	SPORTS - BOYS TENNIS	(2,963.74)	0.00	0.00	(2,963.74)
11 Q 7150 0000 30 300 910010	SPORTS - BOYS TRACK	(10,458.81)	4,418.75	21,060.00	(27,100.06)
11 Q 7150 0000 30 300 910011	SPORTS - BOYS VOLLEYBALL	(8,691.43)	0.00	0.00	(8,691.43)
11 Q 7150 0000 30 300 910012	SPORTS - CHEERLEADERS	(20,683.32)	8,494.08	0.00	(12,189.24)
11 Q 7150 0000 30 300 910013	SPORTS - CROSS COUNTY CO ED	(4,965.52)	0.00	0.00	(4,965.52)
11 Q 7150 0000 30 300 910014	SPORTS - FOOTBALL	(70,150.85)	1,259.03	0.00	(68,891.82)
11 Q 7150 0000 30 300 910015	SPORTS - FOOTBALL JERSEYS	(2,741.97)	0.00	0.00	(2,741.97)
11 Q 7150 0000 30 300 910016	SPORTS - GIRLS BASKETBALL	(10,959.51)	2,918.06	0.00	(8,041.45)
11 Q 7150 0000 30 300 910017	SPORTS - GIRLS BOWLING	(4,549.78)	0.00	0.00	(4,549.78)
11 Q 7150 0000 30 300 910018	SPORTS - GIRLS GOLF	(1,371.89)	0.00	0.00	(1,371.89)
11 Q 7150 0000 30 300 910019	SPORTS - GIRLS SOCCER	(4,066.68)	894.98	0.00	(3,171.70)
11 Q 7150 0000 30 300 910020	SPORTS - GIRLS TENNIS	(4,775.09)	0.00	0.00	(4,775.09)

## Balance Sheet Detail by Fund

March 2023-2024		COUNTY OF GRUNDY SCHOOL DIST 111			
Account	Account Description	Beginning Balance	Debit	Credit	Ending Balance
<b>11 - Activity Fund</b>					
Q - Equity					
11 Q 7150 0000 30 300 910021	SPORTS - GIRLS TRACK	1,487.91	0.00	25.00	1,462.91
11 Q 7150 0000 30 300 910022	SPORTS - GIRLS VOLLEYBALL	(5,238.84)	950.31	0.00	(4,288.53)
11 Q 7150 0000 30 300 910023	SPORTS - LACROSSE	(2,805.75)	0.00	0.00	(2,805.75)
11 Q 7150 0000 30 300 910024	SPORTS - OUTDOOR ED TRIP	(7,546.70)	0.00	2,680.00	(10,226.70)
11 Q 7150 0000 30 300 910025	SPORTS - POMS	(2,791.22)	0.00	4,971.20	(7,762.42)
11 Q 7150 0000 30 300 910026	SPORTS - SOFTBALL	(1,925.45)	0.00	0.00	(1,925.45)
11 Q 7150 0000 30 300 910027	SPORTS - SWIMMING B&G	(1,730.56)	0.00	0.00	(1,730.56)
11 Q 7150 0000 30 300 910028	SPORTS - BOYS WRESTLING	(11,381.49)	73.84	0.00	(11,307.65)
11 Q 7150 0000 30 300 910039	SUMMER CAMPS - SOCCER	0.00	0.00	800.00	(800.00)
11 Q 7150 0000 30 300 910043	FOOTBALL TEAM CAMP	(240.00)	0.00	0.00	(240.00)
11 Q 7150 0000 30 300 910044	SPORTS - GIRLS WRESTLING	(10,209.40)	664.00	0.00	(9,545.40)
11 Q 7150 0000 30 300 920000	ATHLETIC BOOSTERS	1,713.90	0.00	0.00	1,713.90
11 Q 7150 0000 70 300 900001	ACTIVITIES - POP	(2,597.97)	51.98	120.92	(2,666.91)
11 Q 7150 0000 70 300 900002	ACTIVITIES - ART CLUB	(692.10)	0.00	0.00	(692.10)
11 Q 7150 0000 70 300 900003	ACTIVITIES - ATHLETIC LEADERSHIP	(342.50)	0.00	0.00	(342.50)
11 Q 7150 0000 70 300 900005	ACTIVITIES - CHESS	(14.00)	0.00	0.00	(14.00)
11 Q 7150 0000 70 300 900007	ACTIVITIES - CHORUS	(2,509.11)	0.00	0.00	(2,509.11)
11 Q 7150 0000 70 300 900008	ACTIVITIES - CLASS OF 2025	(15,476.33)	0.00	20.16	(15,496.49)
11 Q 7150 0000 70 300 900009	ACTIVITIES - CLASS OF 2026	(672.94)	0.00	0.00	(672.94)
11 Q 7150 0000 70 300 900010	ACTIVITIES - CLASS OF 2027	(4,782.35)	0.00	0.00	(4,782.35)
11 Q 7150 0000 70 300 900013	ACTIVITIES - CLASS OF 2024	(5,606.69)	0.00	20.16	(5,626.85)
11 Q 7150 0000 70 300 900014	ACTIVITIES - COMMUNITY GARDEN	(615.39)	0.00	0.00	(615.39)
11 Q 7150 0000 70 300 900015	ACTIVITIES - CULINARY ARTS	(876.96)	0.00	0.00	(876.96)
11 Q 7150 0000 70 300 900017	ACTIVITIES - DREAM	(500.90)	0.00	0.00	(500.90)
11 Q 7150 0000 70 300 900018	ACTIVITIES - FASHION MERCHANDISING	(223.31)	0.00	0.00	(223.31)
11 Q 7150 0000 70 300 900019	ACTIVITIES - FCCLA	(123.80)	0.00	0.00	(123.80)
11 Q 7150 0000 70 300 900020	ACTIVITIES - FFA	(5,292.59)	0.00	0.00	(5,292.59)
11 Q 7150 0000 70 300 900021	ACTIVITIES - FRENCH NHS	(305.91)	0.00	0.00	(305.91)
11 Q 7150 0000 70 300 900022	ACTIVITIES - FUTURE BUSINESS LEADERS	(140.86)	0.00	0.00	(140.86)

## Balance Sheet Detail by Fund

March 2023-2024		COUNTY OF GRUNDY SCHOOL DIST 111			
Account	Account Description	Beginning Balance	Debit	Credit	Ending Balance
<b>11 - Activity Fund</b>					
Q - Equity					
11 Q 7150 0000 70 300 900023	ACTIVITIES - I.O.T.A.	(2,287.67)	0.00	0.00	(2,287.67)
11 Q 7150 0000 70 300 900024	ACTIVITIES - INDIAN CLIMBING CLUB	(447.80)	0.00	0.00	(447.80)
11 Q 7150 0000 70 300 900025	ACTIVITIES - INDIAN NATION	(90.21)	0.00	0.00	(90.21)
11 Q 7150 0000 70 300 900026	ACTIVITIES - INT'L CLUB	(266.03)	0.00	0.00	(266.03)
11 Q 7150 0000 70 300 900027	ACTIVITIES - THEATER CLUB	(18,448.59)	83.03	0.00	(18,365.56)
11 Q 7150 0000 70 300 900028	ACTIVITIES - INTERACT	(344.98)	0.00	0.00	(344.98)
11 Q 7150 0000 70 300 900029	ACTIVITIES - INVESTMENT CLUB	(108.16)	0.00	0.00	(108.16)
11 Q 7150 0000 70 300 900030	ACTIVITIES - JUDO	(13,709.85)	0.00	0.00	(13,709.85)
11 Q 7150 0000 70 300 900031	ACTIVITIES - KALEIDOSOPE	(1,094.07)	0.00	0.00	(1,094.07)
11 Q 7150 0000 70 300 900032	ACTIVITIES - MAC	(4,967.18)	0.00	0.00	(4,967.18)
11 Q 7150 0000 70 300 900033	ACTIVITIES - MATH TEAM	(246.00)	0.00	0.00	(246.00)
11 Q 7150 0000 70 300 900034	ACTIVITIES - MCHS BOOK CLUB	(529.57)	0.00	0.00	(529.57)
11 Q 7150 0000 70 300 900035	ACTIVITIES - MEMORIAL GARDEN	(888.23)	0.00	0.00	(888.23)
11 Q 7150 0000 70 300 900036	ACTIVITIES - MUSICAL	(5,921.75)	0.00	428.70	(6,350.45)
11 Q 7150 0000 70 300 900037	ACTIVITIES - NEEDY FAMILIES	(7,766.26)	0.00	0.00	(7,766.26)
11 Q 7150 0000 70 300 900038	ACTIVITIES - NHS	(416.70)	0.00	0.00	(416.70)
11 Q 7150 0000 70 300 900039	ACTIVITIES - ORCHESIS	(5,944.83)	1,025.94	1,139.60	(6,058.49)
11 Q 7150 0000 70 300 900040	ACTIVITIES - PAC RESTORATION	(2,911.56)	565.25	1,333.00	(3,679.31)
11 Q 7150 0000 70 300 900041	ACTIVITIES - PERCUSSION	53.98	0.00	0.00	53.98
11 Q 7150 0000 70 300 900043	ACTIVITIES - NEWSPAPER	(1,159.26)	0.00	0.00	(1,159.26)
11 Q 7150 0000 70 300 900044	ACTIVITIES - SADD	(256.41)	0.00	0.00	(256.41)
11 Q 7150 0000 70 300 900045	ACTIVITIES - SCHOLASTIC BOWL	(313.55)	0.00	300.00	(613.55)
11 Q 7150 0000 70 300 900046	ACTIVITIES - SPANISH NHS	(1,049.36)	0.00	0.00	(1,049.36)
11 Q 7150 0000 70 300 900047	ACTIVITIES - SPEECH	(3,376.73)	0.00	0.00	(3,376.73)
11 Q 7150 0000 70 300 900048	ACTIVITIES - STUDENT COUNCIL	(79,058.54)	2,546.60	6,240.00	(82,751.94)
11 Q 7150 0000 70 300 900049	ACTIVITIES - TSA	(844.52)	0.00	0.00	(844.52)
11 Q 7150 0000 70 300 900050	ACTIVITIES - UNDERWATER ROBOTIC	(2,036.75)	0.00	0.00	(2,036.75)

## Balance Sheet Detail by Fund

March	2023-2024	COUNTY OF GRUNDY SCHOOL DIST 111			
Account	Account Description	Beginning Balance	Debit	Credit	Ending Balance
<b>11 - Activity Fund</b>					
Q - Equity					
11 Q 7150 0000 70 300 900051	ACTIVITIES - WINTERGUARD	(1,927.47)	4,506.14	21,675.76	(19,097.09)
11 Q 7150 0000 70 300 900052	ACTIVITIES - WYSE	(418.94)	0.00	0.00	(418.94)
11 Q 7150 0000 70 300 900053	ACTIVITIES - YEARBOOK	(35,533.27)	144.95	0.00	(35,388.32)
11 Q 7150 0000 70 300 900054	ACTIVITIES - ALLIES IN DIVERSITY	108.06	0.00	0.00	108.06
11 Q 7150 0000 70 300 900055	ACTIVITIES - CYBRARY	(1,238.29)	0.00	0.00	(1,238.29)
11 Q 7150 0000 70 300 900056	FACULTY POP	(2,366.14)	0.00	120.92	(2,487.06)
11 Q 7150 0000 70 300 900057	PROJECT INDIAN	(2,085.53)	0.00	0.00	(2,085.53)
11 Q 7150 0000 70 300 900058	ACTIVITIES - PROM	(4,853.19)	3,150.00	0.00	(1,703.19)
11 Q 7150 0000 70 300 900059	SCHOLARSHIP	(249.91)	0.00	0.00	(249.91)
11 Q 7150 0000 70 300 900061	ACTIVITIES - ASL - AMERICAN SIGN LANGUAGE CLUB/NHS	(1,844.86)	0.00	25.74	(1,870.60)
11 Q 7150 0000 70 300 900062	ACTIVITIES - GREEN HOUSE	(1,854.88)	0.00	0.00	(1,854.88)
11 Q 7150 0000 70 300 900064	FOUNDATION SCHOLARSHIP	(5,000.00)	0.00	0.00	(5,000.00)
11 Q 7150 0000 70 300 900065	FOUNDATION ASSIST MCHS ATHLETICS/ACTIVITIES	(1,825.00)	0.00	0.00	(1,825.00)
11 Q 7150 0000 70 300 900066	ACTIVITIES - CONNECTIONS CREW	173.43	0.00	173.43	0.00
11 Q 7150 0000 70 300 920001	BAND BOOSTERS	(24,309.77)	0.00	0.00	(24,309.77)
11 Q 7150 0000 70 300 920002	CHOIR BOOSTERS	25,309.21	0.00	0.00	25,309.21
<b>Totals for: 11 Q - Equity</b>		<b>(778,492.55)</b>	<b>72,313.54</b>	<b>100,455.47</b>	<b>(806,634.48)</b>
<b>Totals for Fund: 11 - Activity Fund</b>		<b>0.00</b>	<b>169,270.99</b>	<b>169,270.99</b>	<b>0.00</b>
		<b>Beginning Balance</b>	<b>Debit</b>	<b>Credit</b>	<b>Ending Balance</b>
<b>Totals for: A - Asset</b>		778,492.55	62,536.82	34,394.89	806,634.48
<b>Totals for: L - Liability</b>		0.00	34,420.63	34,420.63	0.00
<b>Totals for: Q - Equity</b>		(778,492.55)	72,313.54	100,455.47	(806,634.48)
<b>Grand Totals:</b>		<b>0.00</b>	<b>169,270.99</b>	<b>169,270.99</b>	<b>0.00</b>

Input Report

Date

3/31/2024

Cash and Investments Report

	Education	Oper/ Maint.	Debt Service *	Transportation	IMRF/ Soc Sec	Capital **	Working Cash	Tort	Life Safety	Total	Fund 11 Activities	Total Funds
Checking	\$711,647.47	\$27,576.15	\$56,881.22	\$28,238.71	\$36,642.00	\$103,092.33	\$82,379.54	\$17,551.07	\$25,595.40	<b>\$1,089,603.89</b>	\$535,819.86	<b>\$1,625,423.75</b>
Food Service Account	\$906,538.99									<b>\$906,538.99</b>	0	<b>\$906,538.99</b>
Imprest	\$4,344.56	\$2,603.04	\$0.00	\$3,332.76						<b>\$10,280.36</b>	0	<b>\$10,280.36</b>
Insurance Account	\$1,191,377.48	\$449,647.39	\$0.00	\$174,852.47	\$0.00	0	0	38,780.91		<b>\$1,854,658.25</b>	0	<b>\$1,854,658.25</b>
PMA Cash Account	\$2,315,835.15	\$11,849.50	\$1,795,249.34	\$198,011.65	\$33,533.92	\$839,654.74	\$13,275.80	\$55,101.55	\$9,824.05	<b>\$5,272,335.70</b>	0	<b>\$5,272,335.70</b>
IPTIP	\$4,805,029.67	\$2,415,019.37	\$0.00	\$0.00	\$1,135,814.39	\$0.00	\$204,143.59	\$0.00	\$0.00	<b>\$8,560,007.02</b>	0	<b>\$8,560,007.02</b>
<b>Total Cash accounts</b>	<b>\$9,934,773.32</b>	<b>\$2,906,695.45</b>	<b>\$1,852,130.56</b>	<b>\$404,435.59</b>	<b>\$1,205,990.31</b>	<b>\$942,747.07</b>	<b>\$299,798.93</b>	<b>\$111,433.53</b>	<b>\$35,419.45</b>	<b>\$17,693,424.21</b>	<b>\$535,819.86</b>	<b>\$18,229,244.07</b>
PMA Investments	<u>\$8,184,092.57</u>	<u>\$345,704.24</u>	<u>\$3,069,361.73</u>	<u>\$2,411,248.47</u>	<u>\$372,578.68</u>	<u>\$12,400,533.84</u>	<u>\$11,230,264.12</u>	<u>\$604,394.77</u>	<u>\$4,226,150.18</u>	<u>\$42,844,328.60</u>	<u>270,814.62</u>	<u>43,115,143.22</u>
PMA 101 Investments	\$7,543,732.39	\$8,344.51	\$2,411,923.24	\$1,867,189.90	\$344,118.72	\$12,338,154.57	\$5,088,218.79	\$344,363.66	\$3,765,267.45	\$33,711,313.23	-	\$33,711,313.23
PMA 62 (Working Cash)						\$0.00				\$0.00	-	\$0.00
PMA 202						\$0.00				\$0.00	-	\$0.00
PMA 203 - 2006 Bond			\$139,693.73							\$139,693.73	-	\$139,693.73
PMA 65 (Capital)										\$0.00	-	\$0.00
US Bank	\$0.00									\$0.00	-	\$0.00
PMA 205 Working Cash							\$6,052,613.55			\$6,052,613.55	-	\$6,052,613.55
PMA 68										\$0.00	0	\$0.00
PMA 104 - General Reserve	\$640,360.18	\$337,359.73	\$164,535.47	\$544,058.57	\$28,459.96	\$62,379.27	\$89,431.78	\$260,031.11	\$460,882.73	\$2,587,498.80	0	\$2,587,498.80
PMA - 105 Davidson Trust			\$353,209.29							\$353,209.29		\$353,209.29
PMA 208 - Health Life Safety									\$0.00	\$0.00	0	\$0.00
PMA 209 - Capital						\$0.00				\$0.00	0	\$0.00
Private Bank Investments	\$646,329.87	\$1,583.64	\$112,336.88	\$153,709.12	\$7,312.55	\$0.00	\$0.00	\$0.00	\$0.00	\$921,272.06	0	\$921,272.06
PMA 103 - Coady Scholarship										\$0.00	\$270,814.62	\$270,814.62
<b>Total Investments</b>	<b>\$8,830,422.44</b>	<b>\$347,287.88</b>	<b>\$3,181,698.61</b>	<b>\$2,564,957.59</b>	<b>\$379,891.23</b>	<b>\$12,400,533.84</b>	<b>\$11,230,264.12</b>	<b>\$604,394.77</b>	<b>\$4,226,150.18</b>	<b>\$43,765,600.66</b>	<b>270,814.62</b>	<b>\$44,036,415.28</b>
<b>Total Cash &amp; Investments</b>	<b>\$18,765,195.76</b>	<b>\$3,253,983.33</b>	<b>\$5,033,829.17</b>	<b>\$2,969,393.18</b>	<b>\$1,585,881.54</b>	<b>\$13,343,280.91</b>	<b>\$11,530,063.05</b>	<b>\$715,828.30</b>	<b>\$4,261,569.63</b>	<b>\$61,459,024.87</b>	<b>\$806,634.48</b>	<b>\$62,265,659.35</b>

## Expenditure Report

Fiscal Year: 2023-2024  
Month: March

COUNTY OF GRUNDY SCHOOL DIST 111

Fund Description	Account	Account Description	Revised Budget	MTD Activity	Encumbrance	Pending Activity	Available Funds	Year to Date Activity	Percent of Budget Used
Education Fund		TITLE IV SUPPLIES	2,000.00	2,000.00	0.00	0.00	0.00	2,000.00	100.00
Education Fund	111134900	ESSER I Digital Equity Grant	0.00	0.00	0.00	0.00	-87,909.82	87,909.82	0.00
Education Fund	111137000	ESSER I Digital Equity Grant	0.00	0.00	0.00	0.00	0.00	0.00	0.00
Education Fund	11130100	TITLE 1 SALARIES	6,566.10	0.00	0.00	0.00	0.00	6,566.10	100.00
Education Fund	1011130110	HIGH SCHOOL	0.00	0.00	0.00	0.00	0.00	0.00	0.00
Education Fund	11130110	DETENTION HALL SUPVSN	0.00	2,064.00	0.00	0.00	-10,616.00	10,616.00	0.00
Education Fund	11130127	ELL INSTRUCTION	0.00	0.00	0.00	0.00	0.00	0.00	0.00
Education Fund	1113011002	ART SALARY	247,513.20	20,626.10	0.00	0.00	63,626.10	183,887.10	74.29
Education Fund	1113011005	ENGLISH/DRAMA SALARY	1,891,149.84	157,303.58	0.00	0.00	490,341.21	1,400,808.63	74.07
Education Fund	1113011006	FOREIGN LANG SALARY	902,162.64	72,113.90	0.00	0.00	236,539.10	665,623.54	73.78
Education Fund	1113011011	MATH SALARY	1,574,758.56	131,268.88	0.00	0.00	414,031.31	1,160,727.25	15173.71
Education Fund	1113011012	MUSIC SALARY	252,110.52	20,106.90	0.00	0.00	68,441.65	183,668.87	72.85
Education Fund	1113011013	NATURAL SCIENCE	1,415,427.84	117,424.83	0.00	0.00	356,006.98	1,059,420.86	74.85
Education Fund	1113011015	SOCIAL SCIENCE SALARY	1,429,721.28	119,056.11	0.00	0.00	372,402.38	1,057,318.90	73.95
Education Fund	1113011027	DEPT CHAIR SALARY	800,196.24	66,683.02	0.00	0.00	205,711.04	594,485.20	74.29
Education Fund	1113011050	PHYS ED SALARY	1,184,820.30	89,386.46	0.00	0.00	362,162.67	822,657.63	69.43
Education Fund	11130111	OVERLOAD	143,000.00	9,874.94	0.00	0.00	62,636.60	80,363.40	56.20
Education Fund	11130112	PLAN TIME	210,375.00	17,671.92	0.00	0.00	53,321.73	157,053.27	74.65
Education Fund		Interventionist Salary	85,174.08	8,021.10	0.00	0.00	25,219.01	59,955.07	70.39
Education Fund	11130120	CAMPUS MONITOR	0.00	0.00	0.00	0.00	0.00	0.00	0.00
Education Fund	11130121	SUB TEACHER SALARY	375,000.00	27,472.86	0.00	0.00	188,177.22	186,822.78	49.82
Education Fund	11130122	MENTORING	34,056.00	2,268.00	0.00	0.00	12,391.25	21,664.75	63.62
Education Fund	11130125	SUMMER CURRIC	11,600.00	0.00	0.00	0.00	11,113.80	486.20	4.19
Education Fund	11130126	POST RETIREMENT	105,976.00	0.00	0.00	0.00	0.02	105,975.98	100.00

## Expenditure Report

Fiscal Year: 2023-2024  
Month: March

COUNTY OF GRUNDY SCHOOL DIST 111

Fund Description	Account	Account Description	Revised Budget	MTD Activity	Encumbrance	Pending Activity	Available Funds	Year to Date Activity	Percent of Budget Used
Education Fund	11130128	SUMMER SCHOOL SALARY	0.00	0.00	0.00	0.00	-672.38	672.38	0.00
Education Fund	11130130	HOMEBOUND	4,000.00	407.09	0.00	0.00	2,625.72	1,374.28	34.36
Education Fund	10-1130-211	OVERLOAD (IC)	0.00	0.00	0.00	0.00	-33.89	33.89	0.00
Education Fund	1113021	INSTRUCTIONAL TRS	16,708.56	1,232.13	0.00	0.00	6,910.10	9,798.46	58.64
Education Fund	11130211	SUB TEACHER TRS	60,000.00	5,115.29	0.00	0.00	21,101.84	38,898.16	64.83
Education Fund	11130212	MENTORING TRS	3,368.18	272.24	0.00	0.00	767.25	2,600.93	77.22
Education Fund	11130213	SUMMER CURRIC TRS	1,147.25	0.00	0.00	0.00	1,088.89	58.36	5.09
Education Fund	111302135	TRS PENALTY	4,000.00	0.00	0.00	0.00	3,037.00	963.00	24.08
Education Fund	1113021101	INSTRUCTIONAL TRS	0.00	0.00	0.00	0.00	0.00	0.00	0.00
Education Fund	1113021102	ART TRS	29,708.64	2,475.72	0.00	0.00	7,636.94	22,071.70	74.29
Education Fund	1113021105	ENGLISH/DRAMA TRS	226,992.00	18,880.86	0.00	0.00	58,830.36	168,161.64	15274.08
Education Fund	1113021106	FOREIGN LANGUAGE TRS	108,285.36	8,655.73	0.00	0.00	28,373.55	79,911.81	73.80
Education Fund	111302111	MATH TRS	189,017.04	15,756.11	0.00	0.00	49,695.87	139,321.17	73.71
Education Fund	1113021112	MUSIC TRS	30,909.72	2,413.40	0.00	0.00	8,864.30	22,045.42	71.32
Education Fund	1113021113	NAT SCI TRS	169,892.88	14,094.37	0.00	0.00	42,731.71	127,161.17	74.85
Education Fund	1113021115	SOC SCI TRS	171,608.16	14,290.13	0.00	0.00	44,681.60	126,926.56	73.96
Education Fund	1113021121	DRIVER ED TRS	0.00	0.00	0.00	0.00	0.00	0.00	0.00
Education Fund	1113021127	DEPT CHAIR TRS	98,046.72	8,170.56	0.00	0.00	25,205.46	72,841.26	74.29
Education Fund	1113021150	PHYS ED TRS	142,213.08	10,728.94	0.00	0.00	43,470.41	98,742.67	69.43
Education Fund	10-1130-	DEPT CHAIR SALARY (GTL)	0.00	0.00	0.00	0.00	0.00	0.00	0.00
Education Fund	10-1130-222	DIST 111 GROUP MEDICAL	5,134,532.70	444,144.84	0.00	0.00	1,672,554.22	3,461,978.48	67.43
Education Fund	10-1130-	HIGH SCHOOL	0.00	60.82	0.00	0.00	-92.20	92.20	0.00
Education Fund		TEACHING GROUP INS	0.00	0.00	0.00	0.00	-311.74	311.74	0.00
Education Fund		10 E 1130 2220 00 300	0.00	0.00	0.00	0.00	0.00	0.00	0.00

## Expenditure Report

Fiscal Year: 2023-2024  
Month: March

COUNTY OF GRUNDY SCHOOL DIST 111

Fund Description	Account	Account Description	Revised Budget	MTD Activity	Encumbrance	Pending Activity	Available Funds	Year to Date Activity	Percent of Budget Used
Education Fund		10 E 1130 2220 00 300	0.00	0.00	0.00	0.00	0.00	0.00	0.00
Education Fund	1113022201	TEACHING GROUP INS	0.00	0.00	0.00	0.00	0.00	0.00	0.00
Education Fund	1113022202	ART GROUP INS	71,852.62	5,913.34	0.00	0.00	21,452.32	50,400.30	70.14
Education Fund	1113022205	ENGLISH GROUP INS	552,154.94	46,513.54	0.00	0.00	161,634.80	390,520.14	70.73
Education Fund	1113022206	FOREIGN LANG GROUP	335,112.10	26,643.88	0.00	0.00	108,892.51	226,219.59	67.51
Education Fund	1113022211	MATH GROUP INS	470,313.10	37,914.18	0.00	0.00	146,104.73	324,208.37	68.93
Education Fund	1113022212	MUSIC GROUP INS	75,491.86	3,116.16	0.00	0.00	43,227.94	32,263.92	42.74
Education Fund	1113022213	NAT SCI GROUP INS	451,503.43	35,992.10	0.00	0.00	143,899.18	307,604.25	68.13
Education Fund	1113022215	SOC SCI GROUP INS	338,902.34	27,889.52	0.00	0.00	101,196.83	237,705.51	70.14
Education Fund	1113022221	DRIVER ED GROUP INS	0.00	0.00	0.00	0.00	0.00	0.00	0.00
Education Fund	1113022225	CAMPUS MONITOR GROUP	0.00	0.00	0.00	0.00	0.00	0.00	153 0.00
Education Fund	1113022227	DEPT CHAIR GROUP	267,746.69	21,956.56	0.00	0.00	80,550.52	187,196.17	69.92
Education Fund	1113022250	PHYS ED GROUP INS	471,288.58	32,905.48	0.00	0.00	186,767.21	284,521.37	60.37
Education Fund		DIST 111 GROUP DENTAL	210,000.00	15,434.90	0.00	0.00	80,825.38	129,174.62	61.51
Education Fund		10 E 1130 2230 00 300	0.00	2.60	0.00	0.00	-3.37	3.37	0.00
Education Fund		10 E 1130 2230 00 300	0.00	0.00	0.00	0.00	-3.76	3.76	0.00
Education Fund		10 E 1130 2230 00 300	0.00	0.00	0.00	0.00	0.00	0.00	0.00
Education Fund		10 E 1130 2230 00 300	0.00	0.00	0.00	0.00	0.00	0.00	0.00
Education Fund		ART DENTAL INSURANCE	1,428.08	120.78	0.00	0.00	385.70	1,042.38	72.99
Education Fund		ENGLISH DENTAL INS	9,818.17	830.36	0.00	0.00	2,651.77	7,166.40	72.99
Education Fund		FOREIGN LANG DENTAL	8,092.48	483.12	0.00	0.00	3,960.96	4,131.52	51.05
Education Fund		MATH DENTAL INS	952.06	644.16	0.00	0.00	-4,662.29	5,614.35	589.71
Education Fund		MUSIC DENTAL INS	1,428.08	80.52	0.00	0.00	657.60	770.48	53.95
Education Fund		NAT SCI DENTAL INS	9,282.55	684.42	0.00	0.00	3,243.50	6,039.05	65.06

## Expenditure Report

Fiscal Year: 2023-2024  
Month: March

COUNTY OF GRUNDY SCHOOL DIST 111

Fund Description	Account	Account Description	Revised Budget	MTD Activity	Encumbrance	Pending Activity	Available Funds	Year to Date Activity	Percent of Budget Used
Education Fund		SOC SCI DENTAL INS	7,318.84	619.00	0.00	0.00	1,976.95	5,341.89	72.99
Education Fund		DEPT CHAIR DENTAL INS	9,524.34	845.80	0.00	0.00	2,451.54	7,072.80	74.26
Education Fund		PHYS ED DENTAL INS	5,831.34	402.60	0.00	0.00	2,186.73	3,644.61	62.50
Education Fund	11131230	COLLEGE TUITION REIMB	0.00	3,735.00	0.00	0.00	-62,310.00	62,310.00	0.00
Education Fund		10 E 1130 2340 13 300	0.00	0.00	0.00	0.00	0.00	0.00	0.00
Education Fund	1113030006	FOREIGN LANG CONTR	400.00	0.00	0.00	0.00	400.00	0.00	0.00
Education Fund	1113030006	FOREIGN LANG CONT	0.00	0.00	0.00	0.00	0.00	0.00	0.00
Education Fund	1110030012	BAND PURCHASE SERV	13,000.00	400.00	0.00	0.00	7,007.40	5,992.60	46.10
Education Fund	1110030112	CHORUS PURCHASE SERV	14,750.00	1,747.25	941.00	0.00	6,137.61	7,671.39	52.01
Education Fund	1110030212	STRINGS PURCHASE	0.00	0.00	0.00	0.00	0.00	0.00	0.00
Education Fund	1110030012	BAND CONT SERV S	0.00	0.00	0.00	0.00	0.00	0.00	154 0.00
Education Fund	1110030112	CHORUS CONT SERV S	0.00	0.00	0.00	0.00	0.00	0.00	0.00
Education Fund	1110030212	STRINGS CONT SERV S	0.00	0.00	0.00	0.00	0.00	0.00	0.00
Education Fund	1113030021	DRIVER ED CONTRACT	0.00	0.00	0.00	0.00	0.00	0.00	0.00
Education Fund	1113031025	POLICE LIAISON	0.00	0.00	0.00	0.00	0.00	0.00	0.00
Education Fund	1113031125	EVENT SECURITY	0.00	0.00	0.00	0.00	0.00	0.00	0.00
Education Fund	11131314	CURRIC DEVEL/LRNG OBJ	0.00	0.00	0.00	0.00	-180.00	180.00	0.00
Education Fund	11131315	STAFF DEVELOPMENT	0.00	0.00	0.00	0.00	0.00	0.00	0.00
Education Fund	11130322	TOWEL CONTRACT SERV	0.00	0.00	0.00	0.00	0.00	0.00	0.00
Education Fund	1113032302	ART CONTRACT SERV	0.00	0.00	0.00	0.00	0.00	0.00	0.00
Education Fund	1113032302	ART CONT SERV S	0.00	0.00	0.00	0.00	0.00	0.00	0.00
Education Fund	1113032305	ENGLISH CONTRACT SERV	18,000.00	0.00	0.00	0.00	0.00	18,000.00	100.00
Education Fund	1113032305	ENGLISH CONT SERV S	0.00	0.00	0.00	0.00	0.00	0.00	0.00
Education Fund	1110032312	BAND REPAIR & MAINT	8,000.00	11.98	0.00	0.00	3,423.96	4,576.04	57.20

## Expenditure Report

Fiscal Year: 2023-2024  
Month: March

COUNTY OF GRUNDY SCHOOL DIST 111

Fund Description	Account	Account Description	Revised Budget	MTD Activity	Encumbrance	Pending Activity	Available Funds	Year to Date Activity	Percent of Budget Used
Education Fund	1110032412	CHORUS REPAIR & MAINT	1,905.00	240.00	85.00	0.00	900.00	920.00	48.29
Education Fund	1110032512	STRINGS REPAIR & MAINT	0.00	0.00	0.00	0.00	0.00	0.00	0.00
Education Fund	1110032312	BAND REPAIR & MAINT S	0.00	0.00	0.00	0.00	0.00	0.00	0.00
Education Fund	1110032412	CHORUS REPAIR & MAINT	0.00	0.00	0.00	0.00	0.00	0.00	0.00
Education Fund	1110032512	STRINGS REPAIR & MAINT	0.00	0.00	0.00	0.00	0.00	0.00	0.00
Education Fund	1113032313	NAT SCI CONTRACT SERV	3,014.00	0.00	0.00	0.00	-285.00	3,299.00	109.46
Education Fund	1113032313	NAT SCI CONT SERV S	0.00	0.00	0.00	0.00	0.00	0.00	0.00
Education Fund	1113032315	SOC SCI CONTRACT SERV	529.00	0.00	316.44	0.00	-103.88	316.44	59.82
Education Fund	1113032315	SOC SCI CONT SERV S	0.00	0.00	0.00	0.00	0.00	0.00	0.00
Education Fund	1113032350	PHYS ED CONTRACT SERV	6,750.00	0.00	0.00	0.00	2,461.90	4,288.10	63.53
Education Fund	1113032351	BOWING COSTS	0.00	0.00	0.00	0.00	0.00	0.00	155 0.00
Education Fund	1113032350	PHYS ED CONT SERV S	0.00	0.00	0.00	0.00	0.00	0.00	0.00
Education Fund	11130332	GENERAL EDUCATION	0.00	0.00	0.00	0.00	0.00	0.00	0.00
Education Fund	11131332	TYPE 75 TRAVEL	0.00	0.00	0.00	0.00	0.00	0.00	0.00
Education Fund	11130380	UNEMPLOYMENT	0.00	0.00	0.00	0.00	0.00	0.00	0.00
Education Fund	11130381	WORKERS COMP	0.00	0.00	0.00	0.00	0.00	0.00	0.00
Education Fund	1113038021	DRIVER ED CAR	0.00	0.00	0.00	0.00	0.00	0.00	0.00
Education Fund	11130400	TITLE I SUPPLIES	0.00	-10,011.32	0.00	0.00	-6,119.28	6,119.28	0.00
Education Fund	1113040005	ENGLISH RESALE	0.00	0.00	0.00	0.00	0.00	0.00	0.00
Education Fund	1113040011	MATH SUPPLIES RESALE	0.00	0.00	0.00	0.00	0.00	0.00	0.00
Education Fund	1113040050	PHYS ED RESALE	8,195.00	0.00	0.00	0.00	-589.68	8,784.68	107.20
Education Fund	1113040050	PHYS ED RESALE	0.00	0.00	0.00	0.00	0.00	0.00	0.00
Education Fund	11130410	GEN ED	25,000.00	-87.68	0.00	0.00	5,614.35	19,385.65	77.54
Education Fund	11130411	ECOLAB GRANT SUPPLIES	0.00	0.00	0.00	0.00	0.00	0.00	0.00

## Expenditure Report

Fiscal Year: 2023-2024  
Month: March

COUNTY OF GRUNDY SCHOOL DIST 111

Fund Description	Account	Account Description	Revised Budget	MTD Activity	Encumbrance	Pending Activity	Available Funds	Year to Date Activity	Percent of Budget Used
Education Fund	11131410	CURRIC DEVEL/LRNG	1,200.00	0.00	0.00	0.00	412.88	787.12	65.59
Education Fund	11131411	STAFF DEVELOPMENT	0.00	0.00	0.00	0.00	0.00	0.00	0.00
Education Fund	11131412	TPI GRANT SUPPLIES	0.00	0.00	0.00	0.00	0.00	0.00	0.00
Education Fund	111304102	GEN ED SUPPLIES S	0.00	0.00	0.00	0.00	0.00	0.00	0.00
Education Fund	1113041002	ART SUPPLIES	20,080.00	384.53	4,115.14	0.00	5,797.78	10,167.08	50.63
Education Fund	1113041102	ART/COMP TECH	2,100.00	0.00	0.00	0.00	600.15	1,499.85	71.42
Education Fund	1113041002	ART SUPPLIES S	0.00	0.00	0.00	0.00	0.00	0.00	0.00
Education Fund	1113041102	ART/COMP TECH SUPPLY	0.00	0.00	0.00	0.00	0.00	0.00	0.00
Education Fund	1113041005	ENGLISH/DRAMA	5,000.00	242.56	33.98	0.00	4,287.04	678.98	13.58
Education Fund	1113041505	ENGLISH/COMP TECH	0.00	0.00	0.00	0.00	0.00	0.00	0.00
Education Fund	1113041005	ENGLISH/DRAMA SUPPLY	0.00	0.00	0.00	0.00	0.00	0.00	156 0.00
Education Fund	1113041505	ENGLISH/COMP TECH SUP	0.00	0.00	0.00	0.00	0.00	0.00	0.00
Education Fund	1113041006	FOREIGN LANG SUPPLIES	6,381.00	564.53	1,811.55	0.00	217.03	4,352.42	68.21
Education Fund	1113041106	FOREIGN LANG/COMP	0.00	0.00	0.00	0.00	0.00	0.00	0.00
Education Fund	1113041006	FORN LANG SUPPLIES S	0.00	0.00	0.00	0.00	0.00	0.00	0.00
Education Fund	1113041106	FORN LANG COMP TECH S	0.00	0.00	0.00	0.00	0.00	0.00	0.00
Education Fund	1113041011	MATH SUPPLIES	22,333.00	622.57	114.34	0.00	18,364.86	3,853.80	17.26
Education Fund	1113041211	MATH/COMP TECH	1,000.00	0.00	0.00	0.00	1,000.00	0.00	0.00
Education Fund	1113041011	MATH SUPPLIES S	0.00	0.00	0.00	0.00	-1,261.84	1,261.84	0.00
Education Fund	1113041211	MATH/COMP TECH SUP S	0.00	0.00	0.00	0.00	0.00	0.00	0.00
Education Fund	1110041012	BAND SUPPLIES	5,500.00	705.98	152.95	0.00	2,752.92	2,594.13	47.17
Education Fund	1110041112	CHORUS SUPPLIES	3,250.00	19.70	485.48	0.00	2,239.53	524.99	16.15
Education Fund	1110041212	STRINGS SUPPLIES	1,000.00	53.98	0.00	0.00	891.55	108.45	10.85
Education Fund	1113041012	BAND-CHORUS/COMP	0.00	0.00	0.00	0.00	0.00	0.00	0.00

## Expenditure Report

Fiscal Year: 2023-2024  
Month: March

COUNTY OF GRUNDY SCHOOL DIST 111

Fund Description	Account	Account Description	Revised Budget	MTD Activity	Encumbrance	Pending Activity	Available Funds	Year to Date Activity	Percent of Budget Used
Education Fund	1110041012	BAND SUPPLIES S	0.00	0.00	0.00	0.00	0.00	0.00	0.00
Education Fund	1110041112	GENERAL MUSIC	5,750.00	0.00	1,999.98	0.00	1,993.59	1,756.43	30.55
Education Fund	1110041212	STRINGS SUPPLIES S	0.00	0.00	0.00	0.00	0.00	0.00	0.00
Education Fund	1113041012	BAND-CHORUS/COMP	0.00	0.00	0.00	0.00	0.00	0.00	0.00
Education Fund	1113041013	NAT SCI SUPPLIES	31,441.00	347.56	295.27	0.00	11,897.64	19,248.09	61.22
Education Fund	1113041113	NAT SCI/COMP TECH	0.00	0.00	0.00	0.00	0.00	0.00	0.00
Education Fund	1113041013	NAT SCI SUPPLIES S	0.00	0.00	0.00	0.00	0.00	0.00	0.00
Education Fund	1113041113	NAT SCI/COMP TECH S	0.00	0.00	0.00	0.00	0.00	0.00	0.00
Education Fund	1113041015	SOC SCI SUPPLIES	5,000.00	506.22	300.00	0.00	3,674.44	1,025.56	20.51
Education Fund	1113041115	SOC SCI/COMP TECH	0.00	0.00	0.00	0.00	0.00	0.00	0.00
Education Fund	1113041015	SOC SCI SUPPLIES S	0.00	0.00	0.00	0.00	0.00	0.00	157 0.00
Education Fund	1113041115	SCO SCI/COMP TECH S	0.00	0.00	0.00	0.00	0.00	0.00	0.00
Education Fund	1113041021	DRIVER ED SUPPLIES	2,000.00	0.00	0.00	0.00	2,000.00	0.00	0.00
Education Fund	1113041050	PHYS ED SUPPLIES	28,300.00	0.00	1,959.58	0.00	12,177.49	14,162.93	50.05
Education Fund	1113041150	PHYS ED COMP TECH	0.00	0.00	0.00	0.00	0.00	0.00	0.00
Education Fund	1113041050	PHS ED SUPPLIES S	0.00	0.00	0.00	0.00	0.00	0.00	0.00
Education Fund	1113041150	PHYS ED COMP TECH	0.00	0.00	0.00	0.00	0.00	0.00	0.00
Education Fund	11130420	GENERAL EDUC	0.00	0.00	0.00	0.00	0.00	0.00	0.00
Education Fund	111304202	GENERAL ED TEXTBOOKS	0.00	0.00	0.00	0.00	0.00	0.00	0.00
Education Fund	1113042002	ART TEXTBOOKS	0.00	0.00	0.00	0.00	0.00	0.00	0.00
Education Fund	1113042002	ART TEXTBOOKS S	0.00	0.00	0.00	0.00	0.00	0.00	0.00
Education Fund	1113042005	ENGLISH/DRAMA	7,000.00	0.00	0.00	0.00	5,467.07	1,532.93	21.90
Education Fund	1113042005	ENGLISH/DRAMA TEXTBKKS	0.00	0.00	0.00	0.00	-441.35	441.35	0.00
Education Fund	1113042006	FOREIGN LANG	52,115.00	43.80	139.49	0.00	6,724.94	45,250.57	86.83

## Expenditure Report

Fiscal Year: 2023-2024  
Month: March

COUNTY OF GRUNDY SCHOOL DIST 111

Fund Description	Account	Account Description	Revised Budget	MTD Activity	Encumbrance	Pending Activity	Available Funds	Year to Date Activity	Percent of Budget Used
Education Fund	1113042006	FORN LANG TEXTBOOKS S	0.00	0.00	0.00	0.00	0.00	0.00	0.00
Education Fund	1113042011	MATH TEXTBOOKS	40,492.00	0.00	0.00	0.00	3,280.76	37,211.24	91.90
Education Fund	1113042011	MATH TEXTBOOKS S	0.00	0.00	0.00	0.00	0.00	0.00	0.00
Education Fund	1110042012	BAND TEXTBOOKS	0.00	0.00	0.00	0.00	0.00	0.00	0.00
Education Fund	1110042112	MUSIC TEXTBOOKS	945.00	0.00	0.00	0.00	0.21	944.79	99.98
Education Fund	1110042212	STRINGS TEXTBOOKS	150.00	0.00	0.00	0.00	150.00	0.00	0.00
Education Fund	1110042012	BAND TEXTBOOKS S	0.00	0.00	0.00	0.00	0.00	0.00	0.00
Education Fund	1110042112	CHORUS TEXTBOOKS S	0.00	0.00	0.00	0.00	0.00	0.00	0.00
Education Fund	1110042212	STRINGS TEXTBOOKS S	0.00	0.00	0.00	0.00	0.00	0.00	0.00
Education Fund	1113042013	NAT SCI TEXTBOOKS	0.00	0.00	0.00	0.00	0.00	0.00	0.00
Education Fund	1113042013	NAT SCI TEXTBOOKS S	0.00	0.00	0.00	0.00	0.00	0.00	158 0.00
Education Fund	1113042015	SOC SCI TEXTBOOKS	17,000.00	0.00	0.00	0.00	1,421.20	15,578.80	91.64
Education Fund	1113042015	SOC SCI TEXTBOOKS S	0.00	0.00	0.00	0.00	0.00	0.00	0.00
Education Fund	1113042021	DRIVER ED TEXTBOOKS	0.00	0.00	0.00	0.00	0.00	0.00	0.00
Education Fund	1113042050	PHYS ED TEXTBOOKS	0.00	0.00	0.00	0.00	0.00	0.00	0.00
Education Fund	1113042050	PHS ED TEXTBOOKS S	0.00	0.00	0.00	0.00	0.00	0.00	0.00
Education Fund	1113043002	ART PERIODICALS	0.00	0.00	0.00	0.00	0.00	0.00	0.00
Education Fund	1113043002	ART PERIODICALS S	0.00	0.00	0.00	0.00	0.00	0.00	0.00
Education Fund	1113043005	ENGLISH PERIODICALS	0.00	0.00	0.00	0.00	0.00	0.00	0.00
Education Fund	1113043005	ENGLISH PERIODICALS S	0.00	0.00	0.00	0.00	0.00	0.00	0.00
Education Fund	1113043015	SOC SCI PERIODICALS	0.00	0.00	0.00	0.00	0.00	0.00	0.00
Education Fund	1113043015	SOC SCI PERIODICALS S	0.00	0.00	0.00	0.00	0.00	0.00	0.00
Education Fund	1113043050	PHYS ED PERIODICALS	0.00	0.00	0.00	0.00	0.00	0.00	0.00
Education Fund	1113043050	PHYS ED PERIODICALS S	0.00	0.00	0.00	0.00	0.00	0.00	0.00

## Expenditure Report

Fiscal Year: 2023-2024  
Month: March

COUNTY OF GRUNDY SCHOOL DIST 111

Fund Description	Account	Account Description	Revised Budget	MTD Activity	Encumbrance	Pending Activity	Available Funds	Year to Date Activity	Percent of Budget Used
Education Fund	1113049002	ART VIDEO/SOFTWARE	0.00	0.00	0.00	0.00	0.00	0.00	0.00
Education Fund	1113049002	ART VIDEO/SOFTWARE S	0.00	0.00	0.00	0.00	0.00	0.00	0.00
Education Fund	1113049005	ENGLISH	0.00	0.00	0.00	0.00	0.00	0.00	0.00
Education Fund	1113049005	ENGLISH	0.00	0.00	0.00	0.00	0.00	0.00	0.00
Education Fund	1113049006	FOREIGN LANG	0.00	0.00	0.00	0.00	0.00	0.00	0.00
Education Fund	1113049006	FORN LANG	0.00	0.00	0.00	0.00	0.00	0.00	0.00
Education Fund	1113049011	MATH VIDEO/SOFTWARE	480.00	0.00	0.00	0.00	480.00	0.00	0.00
Education Fund	1113049011	MATH VIDEO/SOFTWARE S	0.00	0.00	0.00	0.00	0.00	0.00	0.00
Education Fund	1110049112	BAND VIDEO/SOFTWARE	0.00	0.00	0.00	0.00	0.00	0.00	0.00
Education Fund	1110049212	CHORUS	0.00	0.00	0.00	0.00	0.00	0.00	0.00
Education Fund	1110049312	STRINGS	0.00	0.00	0.00	0.00	0.00	0.00	159 0.00
Education Fund	1110049112	BAND VIDEO/SOFTWARE S	0.00	0.00	0.00	0.00	0.00	0.00	0.00
Education Fund	1110049212	CHORUS	0.00	0.00	0.00	0.00	0.00	0.00	0.00
Education Fund	1110049312	STRINGS	0.00	0.00	0.00	0.00	0.00	0.00	0.00
Education Fund	1113049013	NAT SCI	8,115.00	0.00	0.00	0.00	164.36	7,950.64	97.97
Education Fund	1113049013	NAT SCI	0.00	0.00	0.00	0.00	0.00	0.00	0.00
Education Fund	1113049015	SOC SCI	0.00	0.00	0.00	0.00	0.00	0.00	0.00
Education Fund	1113049015	SOC SCI	0.00	0.00	0.00	0.00	0.00	0.00	0.00
Education Fund	1113049021	DRIVER ED	0.00	0.00	0.00	0.00	0.00	0.00	0.00
Education Fund	1113049050	PE/HEALTH	0.00	0.00	0.00	0.00	0.00	0.00	0.00
Education Fund	1113049050	PHYS ED	0.00	0.00	0.00	0.00	0.00	0.00	0.00
Education Fund	1113054002	ART EQUIPMENT	0.00	0.00	0.00	0.00	0.00	0.00	0.00
Education Fund	1113054002	ART EQUIPMENT S	0.00	0.00	0.00	0.00	0.00	0.00	0.00
Education Fund	1113054005	ENGLISH EQUIPMENT	0.00	0.00	0.00	0.00	-69.81	69.81	0.00

## Expenditure Report

Fiscal Year: 2023-2024  
Month: March

COUNTY OF GRUNDY SCHOOL DIST 111

Fund Description	Account	Account Description	Revised Budget	MTD Activity	Encumbrance	Pending Activity	Available Funds	Year to Date Activity	Percent of Budget Used
Education Fund	1113054005	ENGLISH EQUIPMENT S	0.00	0.00	0.00	0.00	0.00	0.00	0.00
Education Fund	1113054006	FOREIGN LANG	0.00	0.00	0.00	0.00	0.00	0.00	0.00
Education Fund	1113054006	FORN LANG EQUIPMENT S	0.00	0.00	0.00	0.00	0.00	0.00	0.00
Education Fund	1113054011	MATH EQUIPMENT	0.00	0.00	0.00	0.00	0.00	0.00	0.00
Education Fund	1113054011	MATH EQUIPMENT S	0.00	0.00	0.00	0.00	0.00	0.00	0.00
Education Fund	1110054012	BAND EQUIPMENT	11,000.00	0.00	0.00	0.00	11,000.00	0.00	0.00
Education Fund	1110054112	CHORUS EQUIPMENT	10,000.00	0.00	0.00	0.00	10,000.00	0.00	0.00
Education Fund	1110054212	STRINGS EQUIPMENT	0.00	0.00	0.00	0.00	0.00	0.00	0.00
Education Fund	1110054012	BAND EQUIPMENT S	0.00	0.00	0.00	0.00	0.00	0.00	0.00
Education Fund	1110054112	CHORUS EQUIPMENT S	0.00	0.00	0.00	0.00	0.00	0.00	0.00
Education Fund	1110054212	STRINGS EQUIPMENT S	0.00	0.00	0.00	0.00	0.00	0.00	160 0.00
Education Fund	1113054013	NAT SCI EQUIPMENT	0.00	0.00	0.00	0.00	0.00	0.00	0.00
Education Fund	1113054013	NAT SCI EQUIPMENT S	0.00	0.00	0.00	0.00	0.00	0.00	0.00
Education Fund	1113054015	SOC SCI EQUIPMENT	0.00	0.00	0.00	0.00	0.00	0.00	0.00
Education Fund	1113054015	SOC SCI EQUIPMENT S	0.00	0.00	0.00	0.00	0.00	0.00	0.00
Education Fund	1113054021	DRIVER ED EQUIPMENT	0.00	0.00	0.00	0.00	0.00	0.00	0.00
Education Fund	1113054050	PHYS ED EQUIPMENT	0.00	0.00	0.00	0.00	0.00	0.00	0.00
Education Fund	1113054050	PHYS ED EQUIPMENT S	0.00	0.00	0.00	0.00	0.00	0.00	0.00
Education Fund	1113055021	DRIVER ED VEHICLES	25,000.00	0.00	0.00	0.00	2,035.24	22,964.76	91.86
Education Fund	11130642	JJC TUITION	0.00	0.00	0.00	0.00	0.00	0.00	0.00
Education Fund	1113064002	ART DUES/FEES/LIT	0.00	0.00	0.00	0.00	0.00	0.00	0.00
Education Fund	1113064005	ENGLISH DUES/FEES	0.00	0.00	0.00	0.00	0.00	0.00	0.00
Education Fund	1113064005	ENGLISH DUES/FEES/LIT	0.00	0.00	0.00	0.00	0.00	0.00	0.00
Education Fund	1113064006	FOREIGN LANG	0.00	0.00	0.00	0.00	0.00	0.00	0.00

## Expenditure Report

Fiscal Year: 2023-2024  
Month: March

COUNTY OF GRUNDY SCHOOL DIST 111

Fund Description	Account	Account Description	Revised Budget	MTD Activity	Encumbrance	Pending Activity	Available Funds	Year to Date Activity	Percent of Budget Used
Education Fund	1113064006	FORN LANG	0.00	0.00	0.00	0.00	0.00	0.00	0.00
Education Fund	1113064011	MATH DUES & FEES	0.00	0.00	0.00	0.00	0.00	0.00	0.00
Education Fund	1113064011	MATH DUES/FEES/LIT S	0.00	0.00	0.00	0.00	0.00	0.00	0.00
Education Fund	1110064012	BAND CLINICS	1,000.00	0.00	0.00	0.00	1,000.00	0.00	0.00
Education Fund	1110064112	CHORUS CLINICS	1,000.00	-637.20	0.00	0.00	800.00	200.00	20.00
Education Fund	1110064212	STRINGS CLINICS	0.00	0.00	0.00	0.00	0.00	0.00	0.00
Education Fund	1110064312	BAND ENTRY FEES	5,585.00	0.00	250.00	0.00	689.56	4,645.44	83.18
Education Fund	1110064412	CHORUS ENTRY FEES	1,370.00	375.00	0.00	0.00	-119.00	1,489.00	108.69
Education Fund	1110064512	STRINGS ENTRY FEES	300.00	0.00	0.00	0.00	300.00	0.00	0.00
Education Fund	1110064012	BAND CLINICS S	0.00	0.00	0.00	0.00	0.00	0.00	0.00
Education Fund	1110064112	CHORUS CLINICS S	0.00	0.00	0.00	0.00	0.00	0.00	161 0.00
Education Fund	1110064212	STRINGS CLINICS S	0.00	0.00	0.00	0.00	0.00	0.00	0.00
Education Fund	1110064312	BAND ENTRY FEES S	0.00	0.00	0.00	0.00	0.00	0.00	0.00
Education Fund	1110064412	CHORUS ENTRY FEES S	0.00	0.00	0.00	0.00	0.00	0.00	0.00
Education Fund	1110064512	STRINGS ENTRY FEES S	0.00	0.00	0.00	0.00	0.00	0.00	0.00
Education Fund	1113064013	NAT SCI DUES/FEES/LIT	0.00	0.00	0.00	0.00	0.00	0.00	0.00
Education Fund	1113064113	SCIENCE FIELD TRIP	0.00	0.00	0.00	0.00	-300.00	300.00	0.00
Education Fund	1113064013	NAT SCI DUES/FEES/LIT S	0.00	0.00	0.00	0.00	0.00	0.00	0.00
Education Fund	1113064015	SOC SCI DUES/FEES/LIT	0.00	0.00	0.00	0.00	0.00	0.00	0.00
Education Fund	1113064015	SOC SCI DUES/FEES/LIT S	0.00	0.00	0.00	0.00	0.00	0.00	0.00
Education Fund	1113064021	DRIVER ED DUES/FEES/LIT	0.00	0.00	0.00	0.00	0.00	0.00	0.00
Education Fund	1113064050	PHYS ED DUES/FEES/LIT	0.00	0.00	0.00	0.00	0.00	0.00	0.00
Education Fund	1113064050	PHYS ED DUES/FEES/LIT S	0.00	0.00	0.00	0.00	0.00	0.00	0.00
Education Fund	11130800	HOMEBOUND/HOP REG ED	0.00	0.00	0.00	0.00	0.00	0.00	0.00

## Expenditure Report

Fiscal Year: 2023-2024  
Month: March

COUNTY OF GRUNDY SCHOOL DIST 111

Fund Description	Account	Account Description	Revised Budget	MTD Activity	Encumbrance	Pending Activity	Available Funds	Year to Date Activity	Percent of Budget Used
Education Fund	11130690	REFUND ACCOUNT	0.00	0.00	0.00	0.00	0.00	0.00	0.00
Education Fund	11200110	SPECIAL ED SALARY	1,388,517.36	116,217.40	0.00	0.00	371,980.56	1,016,536.80	73.21
Education Fund	11200111	SPECIAL ED AIDES	0.00	0.00	0.00	0.00	0.00	0.00	0.00
Education Fund	11200112	IDEA PART B SP ED	161,358.00	11,338.74	0.00	0.00	51,992.21	109,365.79	67.78
Education Fund	11200113	IDEA PART B SP ED	42,588.00	2,969.26	0.00	0.00	10,011.73	32,576.27	76.49
Education Fund	11200114	IDEA PART B SP ED	0.00	0.00	0.00	0.00	0.00	0.00	0.00
Education Fund		IDEA SALARIES - ARP	0.00	0.00	0.00	0.00	0.00	0.00	0.00
Education Fund	11200211	SPECIAL ED TRS	166,661.28	13,949.39	0.00	0.00	44,611.63	122,049.65	73.23
Education Fund		10 E 1200 2110 00 300	0.00	0.00	0.00	0.00	0.00	0.00	0.00
Education Fund	11200222	SPECIAL ED INSURANCE	417,040.54	42,267.50	0.00	0.00	128,027.30	289,013.24	69.30
Education Fund		SPECIAL ED AIDES INS	0.00	0.00	0.00	0.00	0.00	0.00	162 0.00
Education Fund		IDEA PART B SP ED	46,851.82	931.14	0.00	0.00	29,638.24	17,213.58	36.74
Education Fund		IDEA PART B SP ED	11,431.20	4.20	0.00	0.00	4,812.39	6,618.81	57.90
Education Fund	11200223	IDEA PART B SP ED	0.00	0.00	0.00	0.00	0.00	0.00	0.00
Education Fund		SPEC ED DENTAL INS	9,520.56	883.12	0.00	0.00	2,848.52	6,672.04	70.08
Education Fund		IDEA SEC DENTAL INS	476.03	40.26	0.00	0.00	68.44	407.59	85.62
Education Fund	11200300	SPECIAL ED PURCHASE	0.00	0.00	0.00	0.00	-854.23	854.23	0.00
Education Fund	11200301	IDEA GRANT PURCHASE	11,000.00	0.00	-598.92	0.00	5,717.76	5,881.16	53.47
Education Fund	11200311	COOP HOUSING ASSESS	0.00	0.00	0.00	0.00	0.00	0.00	0.00
Education Fund	11200312	COOP ADMIN ASSESS	0.00	0.00	0.00	0.00	0.00	0.00	0.00
Education Fund		ARP - IDEA PURCHASE	0.00	0.00	0.00	0.00	-3,599.00	3,599.00	0.00
Education Fund	11200410	SPECIAL ED SUPPLIES	3,500.00	1,169.82	64.87	0.00	1,173.22	2,261.91	64.63
Education Fund	11200411	SPECIAL ED COMP TECH	0.00	0.00	0.00	0.00	0.00	0.00	0.00
Education Fund	11200412	IDEA PART B SP ED	0.00	-13,743.95	0.00	0.00	-497.17	497.17	0.00

## Expenditure Report

Fiscal Year: 2023-2024  
Month: March

COUNTY OF GRUNDY SCHOOL DIST 111

Fund Description	Account	Account Description	Revised Budget	MTD Activity	Encumbrance	Pending Activity	Available Funds	Year to Date Activity	Percent of Budget Used
Education Fund		ARP - IDEA SUPPLIES	5,000.00	13,071.30	-52.49	0.00	-10,445.14	15,497.63	309.95
Education Fund	11200420	SPECIAL ED TEXTBOOKS	0.00	0.00	0.00	0.00	0.00	0.00	0.00
Education Fund	11200490	SPECIAL ED	0.00	0.00	0.00	0.00	0.00	0.00	0.00
Education Fund	11200500	IDEA PART B SP ED	0.00	0.00	0.00	0.00	0.00	0.00	0.00
Education Fund		ARP - IDEA EQUIPMENT	70,832.00	0.00	58,534.02	0.00	-53,499.40	65,797.38	92.89
Education Fund	11200641	SPECIAL ED - OTHER	0.00	0.00	0.00	0.00	0.00	0.00	0.00
Education Fund	11200640	SPECIAL ED	0.00	0.00	0.00	0.00	0.00	0.00	0.00
Education Fund	11200800	COOP TUITION	0.00	0.00	0.00	0.00	0.00	0.00	0.00
Education Fund	11200801	OUT OF DIST TUITION	0.00	0.00	0.00	0.00	0.00	0.00	0.00
Education Fund	11200802	COOP HOMEBOUND/HOSP	85,000.00	3,299.91	0.00	945.60	42,124.97	41,929.43	49.33
Education Fund	11250211	COOP TRS	0.00	0.00	0.00	0.00	0.00	0.00	163 0.00
Education Fund	11250311	COOP HOUSING ASSESS	0.00	0.00	0.00	0.00	0.00	0.00	0.00
Education Fund	11250312	COOP ADMN ASSESS	0.00	0.00	0.00	0.00	0.00	0.00	0.00
Education Fund	11250800	COOP TUITION	0.00	0.00	0.00	0.00	0.00	0.00	0.00
Education Fund	11250801	OUT OF DIST TUITION	0.00	0.00	0.00	0.00	0.00	0.00	0.00
Education Fund	11250802	COOP HOMEBOUND/HOSP	0.00	0.00	0.00	0.00	0.00	0.00	0.00
Education Fund	1140041011	CTE SALARY	319,343.28	26,825.02	0.00	0.00	80,986.11	238,357.17	74.64
Education Fund	1140011010	INDUSTRIAL TECH SALARY	236,775.12	19,731.26	0.00	0.00	59,099.07	177,676.05	75.04
Education Fund	11400211	CTE TRS	38,329.92	3,219.83	0.00	0.00	9,720.04	28,609.88	74.64
Education Fund	1140021110	INDUSTRIAL TECH TRS	28,488.00	2,368.30	0.00	0.00	7,161.90	21,326.10	74.86
Education Fund	1140021111	CTE TRS	0.00	0.00	0.00	0.00	0.00	0.00	0.00
Education Fund	10-1400-	CTE GROUP INS	108,667.94	8,943.82	0.00	0.00	32,463.77	76,204.17	70.13
Education Fund	1140022210	IND TECH GROUP INS	107,727.58	7,923.50	0.00	0.00	39,327.81	68,399.77	63.49
Education Fund		CTE DENTAL INS	1,904.11	161.04	0.00	0.00	514.77	1,389.34	72.97

## Expenditure Report

Fiscal Year: 2023-2024  
Month: March

COUNTY OF GRUNDY SCHOOL DIST 111

Fund Description	Account	Account Description	Revised Budget	MTD Activity	Encumbrance	Pending Activity	Available Funds	Year to Date Activity	Percent of Budget Used
Education Fund		IND TECH DENTAL INS	2,142.13	161.04	0.00	0.00	714.51	1,427.62	66.64
Education Fund	1140032310	IND TECH REPAIR/MAINT	10,500.00	3,937.50	13.00	0.00	2,320.07	8,166.93	77.78
Education Fund	1140032310	IND TECH REPAIR/MAINT S	0.00	0.00	0.00	0.00	0.00	0.00	0.00
Education Fund	1140041032	CTEIG SUPPLIES	0.00	0.00	0.00	0.00	0.00	0.00	0.00
Education Fund	11400410	VOC ED GRANT SUPPLIES	0.00	0.00	0.00	0.00	0.00	0.00	0.00
Education Fund	1140041010	IND ARTS COMP TECH	0.00	0.00	0.00	0.00	0.00	0.00	0.00
Education Fund	1140041110	IND TECH SUPPLIES	106,400.00	8,733.82	3,822.09	0.00	33,732.78	68,845.13	64.70
Education Fund	1140041210	ECO LAB GRANT	0.00	0.00	0.00	0.00	0.00	0.00	0.00
Education Fund	1140041010	IND TECH/COMP TECH S	0.00	0.00	0.00	0.00	0.00	0.00	0.00
Education Fund	1140041110	IND TECH SUPPLIES S	0.00	0.00	0.00	0.00	0.00	0.00	0.00
Education Fund	1140042010	IND TECH TEXTBOOKS	0.00	0.00	0.00	0.00	0.00	0.00	164 0.00
Education Fund	1140042010	IND TECH TEXTBOOKS S	0.00	0.00	0.00	0.00	0.00	0.00	0.00
Education Fund	11400490	IND TECH	0.00	0.00	0.00	0.00	0.00	0.00	0.00
Education Fund	114004902	IND TECH	0.00	0.00	0.00	0.00	0.00	0.00	0.00
Education Fund	1140054010	IND TECH EQUIPMENT	0.00	0.00	0.00	0.00	0.00	0.00	0.00
Education Fund	1140054010	IND TECH EQUIPMENT S	0.00	0.00	0.00	0.00	0.00	0.00	0.00
Education Fund	11400640	IND TECH DUES/FEES/LIT	3,200.00	0.00	0.00	0.00	3,200.00	0.00	0.00
Education Fund	114006402	IND TECH DUES/FEES/LIT	0.00	0.00	0.00	0.00	0.00	0.00	0.00
Education Fund	11459800	GAVC TUITION	0.00	0.00	0.00	0.00	0.00	0.00	0.00
Education Fund	1140111001	AG SALARY	222,651.30	14,892.72	0.00	0.00	86,768.37	135,882.93	61.03
Education Fund	1140121101	AG TRS	26,724.36	1,787.54	0.00	0.00	10,414.72	16,309.64	61.03
Education Fund	1140122201	AG GROUP INS	38,851.63	1,929.06	0.00	0.00	20,936.32	17,915.31	46.11
Education Fund		AG DENTAL INS	833.05	80.52	0.00	0.00	194.80	638.25	76.62
Education Fund	1140130001	AG CONTRACT SERV	1,500.00	0.00	0.00	0.00	1,500.00	0.00	0.00

## Expenditure Report

Fiscal Year: 2023-2024  
Month: March

COUNTY OF GRUNDY SCHOOL DIST 111

Fund Description	Account	Account Description	Revised Budget	MTD Activity	Encumbrance	Pending Activity	Available Funds	Year to Date Activity	Percent of Budget Used
Education Fund	1140130001	AG CONT SERVICE S	0.00	0.00	0.00	0.00	0.00	0.00	0.00
Education Fund	1140139001	AG GRANT PUR SERV	0.00	0.00	0.00	0.00	0.00	0.00	0.00
Education Fund	1140140001	AG RESALE SUPPLIES	0.00	0.00	0.00	0.00	0.00	0.00	0.00
Education Fund	1140141001	AG SUPPLIES	19,285.00	1,727.74	0.00	0.00	10,610.41	8,674.59	44.98
Education Fund	1140141101	AG COMP TECH SUPPLIES	0.00	0.00	0.00	0.00	-64.65	64.65	0.00
Education Fund	1140141001	AG SUPPLIES S	0.00	0.00	0.00	0.00	0.00	0.00	0.00
Education Fund	1140141101	AG/COMP TECH SUPPLIES	0.00	0.00	0.00	0.00	0.00	0.00	0.00
Education Fund	1140142001	AG TEXTBOOKS	0.00	0.00	0.00	0.00	0.00	0.00	0.00
Education Fund	1140142001	AG TEXTBOOKS S	0.00	0.00	0.00	0.00	0.00	0.00	0.00
Education Fund	11401430	AG PERIODICALS	0.00	0.00	0.00	0.00	0.00	0.00	0.00
Education Fund	114014302	AG PERIODICALS S	0.00	0.00	0.00	0.00	0.00	0.00	165 0.00
Education Fund	11401490	AG VIDEO/SOFTWARE	0.00	0.00	0.00	0.00	0.00	0.00	0.00
Education Fund	114014902	AG VIDEO/SOFTWARE S	0.00	0.00	0.00	0.00	0.00	0.00	0.00
Education Fund	1140150001	AG GRANT EQUIPMENT	0.00	0.00	0.00	0.00	0.00	0.00	0.00
Education Fund	1140154001	AG EQUIPMENT	0.00	0.00	0.00	0.00	0.00	0.00	0.00
Education Fund	1140154001	AG EQUIPMENT S	0.00	0.00	0.00	0.00	0.00	0.00	0.00
Education Fund	1140164001	AG DUES/FEES/LIT	3,850.00	0.00	0.00	0.00	3,670.00	180.00	4.68
Education Fund	1140164001	AG DUES/FEES/LIT S	0.00	0.00	0.00	0.00	0.00	0.00	0.00
Education Fund	1140711003	BUSINESS ED SALARY	248,521.20	20,710.10	0.00	0.00	63,854.08	184,667.12	74.31
Education Fund	1140721103	BUSINESS ED TRS	29,829.60	2,485.80	0.00	0.00	7,664.33	22,165.27	74.31
Education Fund	1140722203	BUSINESS ED GROUP INS	86,720.30	6,210.72	0.00	0.00	28,669.82	58,050.48	66.94
Education Fund		BUSINESS ED DENTAL INS	1,428.08	120.78	0.00	0.00	385.70	1,042.38	72.99
Education Fund	1140730003	BUSINESS ED PURCHASE	7,200.00	0.00	0.00	0.00	5,009.00	2,191.00	30.43
Education Fund	1140731003	TREES CETI GRANT	0.00	0.00	0.00	0.00	0.00	0.00	0.00

## Expenditure Report

Fiscal Year: 2023-2024  
Month: March

COUNTY OF GRUNDY SCHOOL DIST 111

Fund Description	Account	Account Description	Revised Budget	MTD Activity	Encumbrance	Pending Activity	Available Funds	Year to Date Activity	Percent of Budget Used
Education Fund	1140732303	BUSINESS ED	0.00	0.00	0.00	0.00	0.00	0.00	0.00
Education Fund	1140732303	BUSINESS ED	0.00	0.00	0.00	0.00	0.00	0.00	0.00
Education Fund	1140741003	BUSINESS ED SUPPLIES	3,500.00	0.00	0.00	0.00	3,387.74	112.26	3.21
Education Fund	1140741103	BUSINESS ED COMP TECH	0.00	0.00	0.00	0.00	0.00	0.00	0.00
Education Fund	1140741003	BUSINESS ED SUPPLIES S	0.00	0.00	0.00	0.00	0.00	0.00	0.00
Education Fund	1140741103	BUSINESS ED/COMP TECH	0.00	0.00	0.00	0.00	0.00	0.00	0.00
Education Fund	1140742003	BUSINESS ED TEXTBOOKS	0.00	0.00	0.00	0.00	0.00	0.00	0.00
Education Fund	1140742003	BUSINESS ED TEXTBOOKS	0.00	0.00	0.00	0.00	0.00	0.00	0.00
Education Fund	11407430	BUSINESS ED	0.00	0.00	0.00	0.00	0.00	0.00	0.00
Education Fund	114074302	BUSINESS ED	0.00	0.00	0.00	0.00	0.00	0.00	0.00
Education Fund	1140749003	BUSINESS ED	21,070.00	0.00	0.00	0.00	6,207.00	14,863.00	16670.54
Education Fund	1140749003	BUSINESS ED	0.00	0.00	0.00	0.00	0.00	0.00	0.00
Education Fund	1140754003	BUSINESS ED EQUIPMENT	0.00	0.00	0.00	0.00	0.00	0.00	0.00
Education Fund	1140754003	BUSINESS ED EQUIPMENT	0.00	0.00	0.00	0.00	0.00	0.00	0.00
Education Fund	1140764003	BUSINESS ED	0.00	0.00	0.00	0.00	0.00	0.00	0.00
Education Fund	1140764003	BUSINESS ED	0.00	0.00	0.00	0.00	0.00	0.00	0.00
Education Fund	11410110	VIDEO EDIT SALARY	0.00	0.00	0.00	0.00	0.00	0.00	0.00
Education Fund	11410211	VIDEO EDIT TRS	0.00	0.00	0.00	0.00	0.00	0.00	0.00
Education Fund	11410222	VIDEO EDIT GROUP INS	0.00	0.00	0.00	0.00	0.00	0.00	0.00
Education Fund	11410390	VIDEO EDIT PURCHASE	0.00	0.00	0.00	0.00	0.00	0.00	0.00
Education Fund	114103902	VIDEO EDIT CONT SERV S	0.00	0.00	0.00	0.00	0.00	0.00	0.00
Education Fund	11410400	VIDEO EDIT RESALE	0.00	0.00	0.00	0.00	0.00	0.00	0.00
Education Fund	11410410	VIDEO EDIT SUPPLIES	500.00	51.96	0.00	0.00	371.13	128.87	25.77
Education Fund	11410411	VIDEO EDIT COMP TECH	0.00	0.00	0.00	0.00	0.00	0.00	0.00

## Expenditure Report

Fiscal Year: 2023-2024  
Month: March

COUNTY OF GRUNDY SCHOOL DIST 111

Fund Description	Account	Account Description	Revised Budget	MTD Activity	Encumbrance	Pending Activity	Available Funds	Year to Date Activity	Percent of Budget Used
Education Fund	114104102	VIDEO EDIT SUPPLIES S	0.00	0.00	0.00	0.00	0.00	0.00	0.00
Education Fund	114104112	VIDEO EDIT/COMP TECH S	0.00	0.00	0.00	0.00	0.00	0.00	0.00
Education Fund	11410430	VIDEO EDIT PERIODICALS	0.00	0.00	0.00	0.00	0.00	0.00	0.00
Education Fund	114104302	VIDEO EDIT PERIODICALS	0.00	0.00	0.00	0.00	0.00	0.00	0.00
Education Fund	11410490	VIDEO EDIT	0.00	0.00	0.00	0.00	0.00	0.00	0.00
Education Fund	114104902	VIDEO EDIT	0.00	0.00	0.00	0.00	0.00	0.00	0.00
Education Fund	11410540	VIDEO EDIT EQUIPMENT	3,100.00	0.00	0.00	0.00	1,068.73	2,031.27	65.52
Education Fund	114105402	VIDEO EDIT EQUIPMENT S	0.00	0.00	0.00	0.00	0.00	0.00	0.00
Education Fund	11410640	VIDEO EDIT	0.00	0.00	0.00	0.00	0.00	0.00	0.00
Education Fund	114106402	VIDEO EDIT	0.00	0.00	0.00	0.00	0.00	0.00	0.00
Education Fund	11411110	INST. TECH SALARY	90,619.20	7,551.76	0.00	0.00	23,303.70	67,315.50	16774.28
Education Fund	11411211	INST TECH TRS	10,877.28	906.44	0.00	0.00	2,797.35	8,079.93	74.28
Education Fund	11411222	INST TECH INS	37,644.55	3,098.76	0.00	0.00	11,237.11	26,407.44	70.15
Education Fund		INST TEC DENTAL INS	476.03	40.26	0.00	0.00	128.57	347.46	72.99
Education Fund	11411390	INST TECH PUR SERV	0.00	0.00	0.00	0.00	0.00	0.00	0.00
Education Fund	11411410	INST TECH SUPPLIES	0.00	0.00	0.00	0.00	0.00	0.00	0.00
Education Fund	11411540	INST TECH EQUIPMENT	0.00	0.00	0.00	0.00	0.00	0.00	0.00
Education Fund	11417110	ATHLETIC TRAINER	64,989.01	7,449.54	0.00	0.00	13,462.67	51,526.34	79.28
Education Fund	11417221	ATHLETIC TRAINER INS	0.00	0.00	0.00	0.00	0.00	0.00	0.00
Education Fund	10-1417-	ATHLETIC TRAINER	37,644.55	3,098.76	0.00	0.00	11,237.11	26,407.44	70.15
Education Fund		ATHLETIC TRAINER	476.03	40.26	0.00	0.00	128.57	347.46	72.99
Education Fund	11417332	ATHLETIC TRAINER	0.00	0.00	0.00	0.00	0.00	0.00	0.00
Education Fund	11417390	ATHLETIC TRAINER PUR	0.00	0.00	0.00	0.00	-20,971.25	20,971.25	0.00
Education Fund	11417410	ATHLETIC TRAINER	0.00	0.00	0.00	0.00	-7,801.50	7,801.50	0.00

## Expenditure Report

Fiscal Year: 2023-2024  
Month: March

COUNTY OF GRUNDY SCHOOL DIST 111

Fund Description	Account	Account Description	Revised Budget	MTD Activity	Encumbrance	Pending Activity	Available Funds	Year to Date Activity	Percent of Budget Used
Education Fund	11417540	AHTLETIC TRAINER EQUIP	0.00	0.00	0.00	0.00	0.00	0.00	0.00
Education Fund	11417640	ATHLETIC TRAINER	0.00	0.00	0.00	0.00	0.00	0.00	0.00
Education Fund	1142011009	FAM/CONS SCIENCE	323,138.40	26,928.20	0.00	0.00	89,431.92	233,706.48	72.32
Education Fund	1142021109	FAM/CONS SCIENCE TRS	38,786.16	3,232.17	0.00	0.00	10,734.50	28,051.66	72.32
Education Fund	1142022209	FAM/CONS SCIENCE INS	37,958.18	3,133.56	0.00	0.00	11,295.38	26,662.80	70.24
Education Fund		FAM/CONS SCIENCE	1,666.10	161.04	0.00	0.00	314.04	1,352.06	81.15
Education Fund	1142032309	FAM/CONS SCIENCE	0.00	0.00	0.00	0.00	0.00	0.00	0.00
Education Fund	1142032309	FAM/CONS SCI	0.00	0.00	0.00	0.00	0.00	0.00	0.00
Education Fund	1142041009	FAM/CONS SCIENCE	70,065.00	3,749.08	2,010.97	0.00	35,722.03	32,332.00	46.15
Education Fund	1142041109	FAM/CONS SCI COMP	0.00	0.00	0.00	0.00	0.00	0.00	0.00
Education Fund	1142041009	FAM/CONS SCI SUPPLIES	0.00	0.00	0.00	0.00	0.00	0.00	168 0.00
Education Fund	1142041109	FAM/CONS SCI/COMP	0.00	0.00	0.00	0.00	0.00	0.00	0.00
Education Fund	1142042009	FAM/CONS SCIENCE	0.00	0.00	0.00	0.00	0.00	0.00	0.00
Education Fund	1142042009	FAM/CONS SCI	0.00	0.00	0.00	0.00	0.00	0.00	0.00
Education Fund	1142043009	FAM/CONS SCIENCE	0.00	0.00	0.00	0.00	0.00	0.00	0.00
Education Fund	1142043009	FAM/CONS SCI	0.00	0.00	0.00	0.00	0.00	0.00	0.00
Education Fund	1142049009	FAM/CONS SCI	0.00	0.00	0.00	0.00	0.00	0.00	0.00
Education Fund	1142049009	FAM/CONS SCI	0.00	0.00	0.00	0.00	0.00	0.00	0.00
Education Fund	1142054009	FAM/CONS SCIENCE	23,352.00	0.00	7,384.09	4,119.00	10,647.91	1,201.00	5.14
Education Fund	1142054009	FAM/CONS SCI	0.00	0.00	0.00	0.00	0.00	0.00	0.00
Education Fund	1142064009	FAM/CONS SCI	0.00	0.00	0.00	0.00	0.00	0.00	0.00
Education Fund	1142064009	FAM/CONS SCI	0.00	0.00	0.00	0.00	0.00	0.00	0.00
Education Fund	11421410	TECH PREP SUPPLIES	0.00	0.00	0.00	0.00	0.00	0.00	0.00
Education Fund	11421490	TECH PREP	0.00	0.00	0.00	0.00	0.00	0.00	0.00

## Expenditure Report

Fiscal Year: 2023-2024  
Month: March

COUNTY OF GRUNDY SCHOOL DIST 111

Fund Description	Account	Account Description	Revised Budget	MTD Activity	Encumbrance	Pending Activity	Available Funds	Year to Date Activity	Percent of Budget Used
Education Fund	11421540	TECH PREP EQUIPMENT	0.00	0.00	0.00	0.00	0.00	0.00	0.00
Education Fund	1150011030	ATHLETIC DIRECTOR	100,000.00	8,333.34	0.00	0.00	22,286.96	77,713.04	77.71
Education Fund	1150011130	ATHLETIC DIR SECY	45,922.50	3,826.88	0.00	0.00	11,480.58	34,441.92	75.00
Education Fund	1150011230	ASST ATHLETIC DIR	16,119.84	1,343.32	0.00	0.00	4,144.08	11,975.76	74.29
Education Fund	1150011070	ACTIVITY DIRECTOR	108,337.19	9,028.10	0.00	0.00	27,850.86	80,486.33	74.29
Education Fund	1150011170	ACTIVITY DIR SECY	51,729.30	4,310.78	0.00	0.00	12,932.28	38,797.02	75.00
Education Fund	1150011270	ASST ACTIVITY DIR	17,773.20	1,481.10	0.00	0.00	4,688.35	13,084.85	73.62
Education Fund	1150012170	MAIN OFFICE SECY	0.00	0.00	0.00	0.00	0.00	0.00	0.00
Education Fund	1150012930	WEIGHTROOM	2,500.00	234.00	0.00	0.00	1,296.20	1,203.80	48.15
Education Fund	1150013030	GIRLS BOWLING COACH	15,664.33	467.34	0.00	0.00	1,540.51	14,123.82	90.17
Education Fund	1150013130	EXTRA DUTY COMP-	80,000.00	1,300.00	0.00	0.00	12,349.00	67,651.00	16984.56
Education Fund	1150013230	BOYS GOLF COACH	13,294.32	1,111.50	0.00	0.00	3,385.25	9,909.07	74.54
Education Fund	1150013330	SOFTBALL COACH	41,624.67	1,469.64	0.00	0.00	28,600.76	13,023.91	31.29
Education Fund	1150013430	GIRLS TENNIS COACH	19,600.67	1,284.30	0.00	0.00	8,336.69	11,263.98	57.47
Education Fund	1150013530	BOYS TRACK COACH	38,944.96	5,449.92	0.00	0.00	10,828.11	28,116.85	72.20
Education Fund	1150013630	GIRLS SOCCER COACH	19,179.00	2,546.50	0.00	0.00	-2,129.62	21,308.62	111.10
Education Fund	1150013730	GIRLS VOLLEYBALL	36,600.64	2,155.94	0.00	0.00	7,054.49	29,546.15	80.73
Education Fund	1150013830	CROSS COUNTRY COACH	27,329.24	2,667.84	0.00	0.00	4,116.02	23,213.22	84.94
Education Fund	1150013930	FOOTBALL COACH	93,766.73	6,082.72	0.00	0.00	20,146.30	73,620.43	78.51
Education Fund	1150014030	BASEBALL COACH	45,365.80	3,424.74	0.00	0.00	14,867.09	30,498.71	67.23
Education Fund	1150014130	GIRLS BASKETBALL	38,190.89	2,871.68	0.00	0.00	13,052.06	25,138.83	65.82
Education Fund	1150014230	BOYS WRESTLING COACH	44,021.12	2,076.48	0.00	0.00	15,383.11	28,638.01	65.06
Education Fund	1150014330	BOYS TENNIS COACH	18,079.36	1,376.40	0.00	0.00	13,770.30	4,309.06	23.83
Education Fund	1150014430	BOYS SOCCER COACH	24,687.63	2,478.08	0.00	0.00	3,121.32	21,566.31	87.36

## Expenditure Report

Fiscal Year: 2023-2024  
Month: March

COUNTY OF GRUNDY SCHOOL DIST 111

Fund Description	Account	Account Description	Revised Budget	MTD Activity	Encumbrance	Pending Activity	Available Funds	Year to Date Activity	Percent of Budget Used
Education Fund	1150014530	CHEERLEADER COACH	29,729.12	0.00	0.00	0.00	846.24	28,882.88	97.15
Education Fund	1150014630	POMS COACH	32,742.53	698.20	0.00	0.00	1,510.31	31,232.22	95.39
Education Fund	1150014730	BOYS BASKETBALL	39,502.97	1,447.04	0.00	0.00	3,385.85	36,117.12	91.43
Education Fund	1150014830	BOYS BOWLING COACH	11,992.48	653.36	0.00	0.00	1,611.10	10,381.38	86.57
Education Fund	1150014930	GIRLS GOLF COACH	9,657.38	676.44	0.00	0.00	3,440.41	6,216.97	64.38
Education Fund	1150015030	GIRLS TRACK COACH	41,438.08	3,050.88	0.00	0.00	14,900.24	26,537.84	64.04
Education Fund	1150015130	BOYS VOLLEYBALL	38,427.26	2,601.64	0.00	0.00	16,201.38	22,225.88	57.84
Education Fund	1150015230	ATHLETIC SCHEDULER	0.00	0.00	0.00	0.00	0.00	0.00	0.00
Education Fund	1150015330	POST SEASON SALARY	0.00	0.00	0.00	0.00	0.00	0.00	0.00
Education Fund	1150015430	INVITATIONAL WKRS	0.00	0.00	0.00	0.00	0.00	0.00	0.00
Education Fund	1150015530	BOYS LACROSSE COACH	30,591.60	459.34	0.00	0.00	26,733.17	3,858.43	17012.61
Education Fund	1150015630	GIRLS LACROSSE COACH	22,268.48	843.34	0.00	0.00	13,527.64	8,740.84	39.25
Education Fund		GIRLS WRESTLING COACH	22,687.39	3,973.76	0.00	0.00	5,027.23	17,660.16	77.84
Education Fund		ATHLETIC PERFORMANCE	13,836.24	1,153.02	0.00	0.00	3,556.86	10,279.38	74.29
Education Fund	1150012970	STDNT ACT SENIOR	3,060.00	255.00	0.00	0.00	786.75	2,273.25	74.29
Education Fund	1150013070	FALL PLAY/CHLDRNS	5,529.20	370.34	0.00	0.00	-686.44	6,215.64	112.41
Education Fund	1150013170	TECH STDNT ASSOC	7,092.47	595.08	0.00	0.00	1,787.31	5,305.16	74.80
Education Fund	1150013171	EXTRA DUTY COMP-	32,000.00	3,613.00	0.00	91.00	9,794.50	22,114.50	69.11
Education Fund	1150013270	SCHOLASTIC BOWL	5,381.80	463.56	0.00	0.00	1,267.28	4,114.52	76.45
Education Fund	1150013370	SPEECH SPONSOR	13,040.48	836.62	0.00	0.00	2,468.41	10,572.07	81.07
Education Fund	1150013470	INTL CLUB SPONSOR	5,552.72	502.24	0.00	0.00	1,133.85	4,418.87	79.58
Education Fund	1150013570	INTL THESPIANS	1,800.00	150.00	0.00	0.00	568.95	1,231.05	68.39
Education Fund	1150013670	INDIANS ON THE AIR	2,611.19	219.08	0.00	0.00	658.00	1,953.19	74.80
Education Fund	1150013770	BAND ACTIVITIES	26,171.60	3,746.64	0.00	0.00	7,148.58	19,023.02	72.69

## Expenditure Report

Fiscal Year: 2023-2024  
Month: March

COUNTY OF GRUNDY SCHOOL DIST 111

Fund Description	Account	Account Description	Revised Budget	MTD Activity	Encumbrance	Pending Activity	Available Funds	Year to Date Activity	Percent of Budget Used
Education Fund	1150013870	CHOIR ACTIVITIES	10,475.79	872.74	0.00	0.00	2,695.29	7,780.50	74.27
Education Fund	1150013970	NHS SPONSOR	10,149.01	844.60	0.00	0.00	2,673.67	7,475.34	73.66
Education Fund	1150014070	YEARBOOK SPONSOR	5,772.45	663.48	0.00	0.00	124.52	5,647.93	97.84
Education Fund	1150014170	SENIOR CLASS SPONSOR	6,614.01	528.22	0.00	0.00	1,904.72	4,709.29	71.20
Education Fund	1150014270	FBLA SPONSOR	0.00	0.00	0.00	0.00	0.00	0.00	0.00
Education Fund	1150014370	STUDENT COUNCIL	18,696.87	1,611.40	0.00	0.00	4,331.07	14,365.80	76.84
Education Fund	1150014470	SOPH CLASS SPONSOR	0.00	0.00	0.00	0.00	0.00	0.00	0.00
Education Fund	1150014570	MUSICAL	15,016.39	296.26	0.00	0.00	12,401.44	2,614.95	17.41
Education Fund	1150014670	WYSE SPONSOR	2,444.63	222.20	0.00	0.00	489.79	1,954.84	79.96
Education Fund	1150014770	ENVIRONMENTAL CLUB	0.00	0.00	0.00	0.00	0.00	0.00	0.00
Education Fund	1150014870	JSA SPONSOR	0.00	0.00	0.00	0.00	0.00	0.00	171 0.00
Education Fund	1150014970	JUNIOR CLASS SPONSOR	7,719.03	689.00	0.00	0.00	1,641.63	6,077.40	78.73
Education Fund	1150015070	FRESHMAN CLASS	0.00	0.00	0.00	0.00	0.00	0.00	0.00
Education Fund	1150015170	SADD/TATU SPONSOR	3,825.18	321.54	0.00	0.00	958.68	2,866.50	74.94
Education Fund	1150015270	WEB SITE SPONSOR	0.00	0.00	0.00	0.00	0.00	0.00	0.00
Education Fund	1150015370	ART CLUB SPONSOR	2,340.54	195.00	0.00	0.00	602.19	1,738.35	74.27
Education Fund	1150015470	FFA SPONSOR	7,919.20	345.22	0.00	0.00	3,136.86	4,782.34	60.39
Education Fund	1150015570	MATH CLUB SPONSOR	5,674.12	491.26	0.00	0.00	1,320.82	4,353.30	76.72
Education Fund	1150015670	FLAG	8,838.66	229.66	0.00	0.00	-6,518.68	15,357.34	173.75
Education Fund	1150015770	FRENCH NHS SPONSOR	1,800.00	255.00	0.00	0.00	-324.75	2,124.75	118.04
Education Fund	1150015870	LITERARY MAGAZINE	3,111.37	259.24	0.00	0.00	800.32	2,311.05	74.28
Education Fund	1150015970	SPANISH NHS SPONSOR	3,060.69	255.00	0.00	0.00	787.44	2,273.25	74.27
Education Fund	1150016070	NEWSPAPER SPONSOR	6,391.31	857.04	0.00	0.00	-789.96	7,181.27	112.36
Education Fund	1150016170	INVESTMENT CLUB	3,060.69	255.00	0.00	0.00	787.44	2,273.25	74.27

## Expenditure Report

Fiscal Year: 2023-2024  
Month: March

COUNTY OF GRUNDY SCHOOL DIST 111

Fund Description	Account	Account Description	Revised Budget	MTD Activity	Encumbrance	Pending Activity	Available Funds	Year to Date Activity	Percent of Budget Used
Education Fund	1150016270	PIT ORCHESTRA	2,889.11	2,417.04	0.00	0.00	472.07	2,417.04	83.66
Education Fund	1150016370	MUSICAL VOCAL	4,222.54	351.78	0.00	0.00	1,086.32	3,136.22	74.27
Education Fund	1150016470	TECH DIRECTOR	1,625.27	0.00	0.00	0.00	1,455.04	170.23	10.47
Education Fund	1150016570	PERCUSSION	1,958.03	1,800.00	0.00	0.00	158.03	1,800.00	91.93
Education Fund	1150016670	ODESSEY BOOK CLUB	1,958.03	165.00	0.00	0.00	487.13	1,470.90	75.12
Education Fund	1150016770	MADRIGAL SPONSOR	1,980.43	0.00	0.00	0.00	1,980.43	0.00	0.00
Education Fund	1150016870	HOPE SPONSOR	0.00	0.00	0.00	0.00	0.00	0.00	0.00
Education Fund	1150016970	MARK SPONSOR	0.00	0.00	0.00	0.00	0.00	0.00	0.00
Education Fund	1150017070	IALC SPONSOR	2,160.47	195.00	0.00	0.00	443.27	1,717.20	79.48
Education Fund	1150017170	INTERACT CLUB SPONSOR	5,074.01	425.60	0.00	0.00	1,279.76	3,794.25	74.78
Education Fund	1150017270	STUDENT ACTIVITIES	0.00	0.00	0.00	0.00	0.00	0.00	172 0.00
Education Fund	1150017370	MADRIGAL HELPERS	0.00	0.00	0.00	0.00	0.00	0.00	0.00
Education Fund	1150017470	MAC SPONSOR	9,471.97	499.64	0.00	0.00	3,501.85	5,970.12	63.03
Education Fund	1150017570	CLIMBING CLUB SPONSOR	2,160.47	195.00	0.00	0.00	443.27	1,717.20	79.48
Education Fund	1150017670	INDOOR PERCUSSION	5,385.04	229.66	0.00	0.00	3,662.59	1,722.45	31.99
Education Fund	1150017770	ORCHESIS SPONSOR	4,831.60	402.64	0.00	0.00	1,220.67	3,610.93	74.74
Education Fund	1150017870	CHESS CLUB SPONSOR	2,666.40	222.20	0.00	0.00	685.50	1,980.90	74.29
Education Fund	1150017970	SUMMER CAMP COACHES	55,054.00	0.00	0.00	0.00	64,354.54	-9,300.54	-16.89
Education Fund	1150018070	JAZZ TRANSIT CHOIR	1,800.00	0.00	0.00	0.00	1,800.00	0.00	0.00
Education Fund	1150018170	UNDERWATER ROV	2,888.60	240.72	0.00	0.00	742.53	2,146.07	74.29
Education Fund	1150018270	PAC LIGHT/SOUND	6,063.20	459.34	0.00	0.00	614.15	5,449.05	89.87
Education Fund		YMCA TEEN ACHIEVERS	1,500.00	0.00	0.00	0.00	1,312.50	187.50	12.50
Education Fund	1150013007	E-SPORTS	7,368.00	614.00	0.00	0.00	1,894.02	5,473.98	74.29
Education Fund		ASL CLUB SPONSOR	3,780.00	315.00	0.00	0.00	993.00	2,787.00	73.73

## Expenditure Report

Fiscal Year: 2023-2024  
Month: March

COUNTY OF GRUNDY SCHOOL DIST 111

Fund Description	Account	Account Description	Revised Budget	MTD Activity	Encumbrance	Pending Activity	Available Funds	Year to Date Activity	Percent of Budget Used
Education Fund		ALLIES IN DIVERSITY	1,980.00	165.00	0.00	0.00	509.13	1,470.87	74.29
Education Fund		DISC GOLF SPONSOR	3,960.00	330.00	0.00	0.00	975.60	2,984.40	75.36
Education Fund		PHOTOGRAPHY	2,160.00	180.00	0.00	0.00	576.63	1,583.37	73.30
Education Fund		GAME CLUB SPONSOR	1,800.00	150.00	0.00	0.00	462.75	1,337.25	74.29
Education Fund		JUDO SPONSOR	2,666.40	222.20	0.00	0.00	685.50	1,980.90	74.29
Education Fund		MOCK TRIAL SPONSOR	2,444.20	203.68	0.00	0.00	628.47	1,815.73	74.29
Education Fund		CONNECTIONS CREW	5,512.00	459.32	0.00	0.00	2,067.10	3,444.90	62.50
Education Fund	10-1500-211	INVITATIONAL WORKERS	0.00	0.00	0.00	0.00	0.00	0.00	0.00
Education Fund	10-1500-	ASST ATHLETIC DIR	0.00	0.00	0.00	0.00	0.00	0.00	0.00
Education Fund	1150021130	ATHLETIC TRS	31,330.27	1,049.17	0.00	0.00	21,995.75	9,334.52	29.79
Education Fund	1150021230	ASST ATHLETIC DIRECTOR	1,950.96	56.10	0.00	0.00	1,307.49	643.47	17332.98
Education Fund		ATH/ACT	9,040.69	279.80	0.00	0.00	2,995.78	6,044.91	66.86
Education Fund		ATH/ACT	1,655.65	133.42	0.00	0.00	466.30	1,189.35	71.84
Education Fund		ATH/ACT	3,492.29	176.38	0.00	0.00	1,929.22	1,563.07	44.76
Education Fund		ATH/ACT	1,663.20	112.26	0.00	0.00	625.41	1,037.79	62.40
Education Fund		ATH/ACT	4,063.87	654.16	0.00	0.00	688.91	3,374.96	83.05
Education Fund		ATH/ACT	2,388.47	305.70	0.00	0.00	-169.31	2,557.78	107.09
Education Fund		ATH/ACT	3,981.66	258.76	0.00	0.00	435.50	3,546.16	89.06
Education Fund		ATH/ACT	3,281.07	320.24	0.00	0.00	494.69	2,786.38	84.92
Education Fund		ATH/ACT	8,121.47	731.51	0.00	0.00	1,693.78	6,427.69	79.14
Education Fund		ATH/ACT	5,260.48	412.32	0.00	0.00	1,588.78	3,671.70	69.80
Education Fund		ATH/ACT	3,792.69	237.40	0.00	0.00	1,655.90	2,136.79	56.34
Education Fund		ATH/ACT	4,075.49	187.95	0.00	0.00	2,410.93	1,664.56	40.84
Education Fund		ATH/ACT	1,619.13	165.23	0.00	0.00	1,101.83	517.30	31.95

## Expenditure Report

Fiscal Year: 2023-2024  
Month: March

COUNTY OF GRUNDY SCHOOL DIST 111

Fund Description	Account	Account Description	Revised Budget	MTD Activity	Encumbrance	Pending Activity	Available Funds	Year to Date Activity	Percent of Budget Used
Education Fund		ATH/ACT	2,856.27	232.00	0.00	0.00	856.60	1,999.67	70.01
Education Fund		ATH/ACT	3,933.66	83.80	0.00	0.00	3,043.06	890.60	22.64
Education Fund		ATH/ACT	4,517.54	173.68	0.00	0.00	788.73	3,728.81	82.54
Education Fund		ATH/ACT	1,446.37	78.42	0.00	0.00	747.25	699.12	48.34
Education Fund		ATH/ACT	1,164.42	81.22	0.00	0.00	418.05	746.37	64.10
Education Fund		ATH/ACT	4,115.00	366.17	0.00	0.00	929.92	3,185.08	77.40
Education Fund		ATH/ACT	3,970.73	312.24	0.00	0.00	1,303.25	2,667.48	67.18
Education Fund		ATH/ACT	661.44	55.12	0.00	0.00	198.43	463.01	70.00
Education Fund		10 E 1500 2110 30 300	0.00	0.00	0.00	0.00	0.00	0.00	0.00
Education Fund		ATH/ACT	1,547.97	171.60	0.00	0.00	31.06	1,516.91	97.99
Education Fund		ATH/ACT	1,660.32	138.36	0.00	0.00	426.74	1,233.58	17474.30
Education Fund	1150021171	ACTIVITIES TRS	14,463.93	1,136.78	0.00	0.00	4,329.39	10,134.54	70.07
Education Fund	1150021270	ATH/ACT	933.03	44.41	0.00	0.00	453.74	479.29	51.37
Education Fund		ATH/ACT	2,863.18	249.20	0.00	0.00	655.88	2,207.30	77.09
Education Fund		ATH/ACT	1,683.84	196.59	0.00	0.00	415.24	1,268.60	75.34
Education Fund		ATH/ACT	646.04	55.65	0.00	0.00	152.09	493.95	76.46
Education Fund		ATH/ACT	1,565.32	100.42	0.00	0.00	296.38	1,268.94	81.07
Education Fund		ATH/ACT	819.97	60.28	0.00	0.00	289.66	530.31	64.67
Education Fund		ATH/ACT	2,588.40	17.98	0.00	0.00	2,440.68	147.72	5.71
Education Fund		ATH/ACT	313.11	26.30	0.00	0.00	78.68	234.43	74.87
Education Fund		ATH/ACT	2,657.40	233.56	0.00	0.00	590.53	2,066.87	77.78
Education Fund		ATH/ACT	1,257.09	104.76	0.00	0.00	323.19	933.90	74.29
Education Fund		ATH/ACT	1,227.03	101.94	0.00	0.00	324.74	902.29	73.53
Education Fund		ATH/ACT	684.04	79.66	0.00	0.00	5.98	678.06	99.13

## Expenditure Report

Fiscal Year: 2023-2024  
Month: March

COUNTY OF GRUNDY SCHOOL DIST 111

Fund Description	Account	Account Description	Revised Budget	MTD Activity	Encumbrance	Pending Activity	Available Funds	Year to Date Activity	Percent of Budget Used
Education Fund		ATH/ACT	795.49	63.40	0.00	0.00	230.24	565.25	71.06
Education Fund		ATH/ACT	2,243.96	193.40	0.00	0.00	519.68	1,724.28	76.84
Education Fund		ATH/ACT	33.38	0.00	0.00	0.00	33.38	0.00	0.00
Education Fund		ATH/ACT	400.03	35.54	0.00	0.00	86.31	313.72	78.42
Education Fund		ATH/ACT	293.46	26.66	0.00	0.00	58.89	234.57	79.93
Education Fund		ATH/ACT	926.72	82.72	0.00	0.00	197.09	729.63	78.73
Education Fund		ATH/ACT	33.34	0.00	0.00	0.00	33.34	0.00	0.00
Education Fund		ATH/ACT	459.03	38.62	0.00	0.00	114.78	344.25	75.00
Education Fund		ATH/ACT	281.16	23.41	0.00	0.00	72.40	208.76	74.25
Education Fund		ATH/ACT	1,476.16	41.44	0.00	0.00	902.13	574.03	38.89
Education Fund		ATH/ACT	680.74	58.94	0.00	0.00	158.43	522.31	17576.73
Education Fund		ATH/ACT	266.90	27.58	0.00	0.00	28.58	238.32	89.29
Education Fund		ATH/ACT	189.49	30.64	0.00	0.00	-65.73	255.22	134.69
Education Fund		ATH/ACT	373.31	31.12	0.00	0.00	95.90	277.41	74.31
Education Fund		ATH/ACT	367.71	30.60	0.00	0.00	94.89	272.82	74.19
Education Fund		ATH/ACT	766.81	102.88	0.00	0.00	-95.18	861.99	112.41
Education Fund		ATH/ACT	367.65	30.60	0.00	0.00	94.83	272.82	74.21
Education Fund		ATH/ACT	346.80	0.00	0.00	0.00	346.79	0.01	0.00
Education Fund		ATH/ACT	507.47	42.26	0.00	0.00	130.73	376.74	74.24
Education Fund		ATH/ACT	195.00	0.00	0.00	0.00	174.57	20.43	10.48
Education Fund		ATH/ACT	234.97	19.82	0.00	0.00	58.32	176.65	75.18
Education Fund		ATH/ACT	259.54	23.40	0.00	0.00	53.46	206.08	79.40
Education Fund		ATH/ACT	609.33	51.10	0.00	0.00	153.73	455.60	74.77
Education Fund		ATH/ACT	713.22	59.98	0.00	0.00	178.48	534.74	74.98

## Expenditure Report

Fiscal Year: 2023-2024  
Month: March

COUNTY OF GRUNDY SCHOOL DIST 111

Fund Description	Account	Account Description	Revised Budget	MTD Activity	Encumbrance	Pending Activity	Available Funds	Year to Date Activity	Percent of Budget Used
Education Fund		ATH/ACT	259.14	23.40	0.00	0.00	53.03	206.11	79.54
Education Fund		ATH/ACT	363.99	27.58	0.00	0.00	157.14	206.85	56.83
Education Fund		ATH/ACT	33.37	18.00	0.00	0.00	-127.15	160.52	481.03
Education Fund		ATH/ACT	316.69	26.67	0.00	0.00	78.92	237.77	75.08
Education Fund		ATH/ACT	4,992.56	0.00	0.00	0.00	542.83	4,449.73	89.13
Education Fund		ATH/ACT	343.58	28.86	0.00	0.00	86.24	257.34	74.90
Education Fund		10 E 1500 2110 70 300	0.00	55.14	0.00	0.00	-413.55	413.55	0.00
Education Fund		ATH/ACT	202.81	0.00	0.00	0.00	180.32	22.49	11.09
Education Fund		ATH/ACT	940.21	73.70	0.00	0.00	283.15	657.06	69.88
Education Fund		ATH/ACT	378.08	37.82	0.00	0.00	43.49	334.59	88.50
Education Fund		ATH/ACT	0.00	0.00	0.00	0.00	0.00	0.00	176 0.00
Education Fund		ATH/ACT	453.64	39.63	0.00	0.00	95.23	358.41	79.01
Education Fund		ATH/ACT	207.64	21.62	0.00	0.00	17.54	190.10	91.55
Education Fund		ATH/ACT	189.04	18.00	0.00	0.00	28.57	160.47	84.89
Education Fund		ATH/ACT	279.99	26.68	0.00	0.00	42.18	237.81	84.94
Education Fund		ATH/ACT	256.84	24.44	0.00	0.00	38.97	217.87	84.83
Education Fund		ATH/ACT	661.44	55.12	0.00	0.00	248.04	413.40	62.50
Education Fund	10-1500-	ATHLETIC DIRECTOR	0.00	0.00	0.00	0.00	0.00	0.00	0.00
Education Fund	10-1500-	ACTIVITY DIRECTOR	0.00	0.00	0.00	0.00	0.00	0.00	0.00
Education Fund	10-1500-222	INVITATIONAL WKRS	0.00	0.00	0.00	0.00	0.00	0.00	0.00
Education Fund	11500222	MAIN OFFICE INS	0.00	0.00	0.00	0.00	0.00	0.00	0.00
Education Fund	10-1500-	ASST ATHLETIC DIR	0.00	0.00	0.00	0.00	0.00	0.00	0.00
Education Fund	1150022230	ATHLETIC DIR/SECY	24,270.31	1,986.92	0.00	0.00	7,325.80	16,944.51	69.82
Education Fund		ATH/ACT	21,985.60	988.92	0.00	0.00	13,553.56	8,432.04	38.35

## Expenditure Report

Fiscal Year: 2023-2024  
Month: March

COUNTY OF GRUNDY SCHOOL DIST 111

Fund Description	Account	Account Description	Revised Budget	MTD Activity	Encumbrance	Pending Activity	Available Funds	Year to Date Activity	Percent of Budget Used
Education Fund		ATH/ACT	283.09	0.00	0.00	0.00	-1,303.73	1,586.82	560.54
Education Fund		10 E 1500 2220 30 300	0.00	0.00	0.00	0.00	0.00	0.00	0.00
Education Fund		ATH/ACT	0.00	0.00	0.00	0.00	0.00	0.00	0.00
Education Fund		ATH/ACT	0.00	0.00	0.00	0.00	0.00	0.00	0.00
Education Fund		10 E 1500 2220 30 300	0.00	0.00	0.00	0.00	0.00	0.00	0.00
Education Fund		ATH/ACT	0.00	0.00	0.00	0.00	0.00	0.00	0.00
Education Fund		ATH/ACT	0.00	0.00	0.00	0.00	0.00	0.00	0.00
Education Fund		ATH/ACT	0.00	0.00	0.00	0.00	0.00	0.00	0.00
Education Fund		ATH/ACT	0.00	0.00	0.00	0.00	0.00	0.00	0.00
Education Fund	1150022270	STUDENT ACT/SECY	36,094.34	2,959.74	0.00	0.00	10,859.73	25,234.61	69.91
Education Fund		ATH/ACT	37,644.55	3,098.76	0.00	0.00	11,237.11	26,407.44	17770.15
Education Fund		ATH/ACT	0.00	0.00	0.00	0.00	0.00	0.00	0.00
Education Fund		ATH/ACT	0.00	0.00	0.00	0.00	-710.65	710.65	0.00
Education Fund		ATH/ACT	0.00	0.00	0.00	0.00	0.00	0.00	0.00
Education Fund		ATH/ACT	0.00	0.00	0.00	0.00	0.00	0.00	0.00
Education Fund		10 E 1500 2220 70 300	0.00	0.00	0.00	0.00	0.00	0.00	0.00
Education Fund		ATH/ACT	0.00	0.00	0.00	0.00	0.00	0.00	0.00
Education Fund		10 E 1500 2220 70 300	0.00	0.00	0.00	0.00	0.00	0.00	0.00
Education Fund		ATH/ACT	0.00	0.00	0.00	0.00	0.00	0.00	0.00
Education Fund		ATH/ACT	0.00	0.00	0.00	0.00	0.00	0.00	0.00
Education Fund		ATH/ACT	0.00	0.00	0.00	0.00	0.00	0.00	0.00
Education Fund		ATH/ACT	2,724.60	82.70	0.00	0.00	2,010.78	713.82	26.20
Education Fund		ATH/ACT	516.84	40.26	0.00	0.00	169.38	347.46	67.23
Education Fund		ATH/ACT	0.00	0.00	0.00	0.00	-17.02	17.02	0.00

## Expenditure Report

Fiscal Year: 2023-2024  
Month: March

COUNTY OF GRUNDY SCHOOL DIST 111

Fund Description	Account	Account Description	Revised Budget	MTD Activity	Encumbrance	Pending Activity	Available Funds	Year to Date Activity	Percent of Budget Used
Education Fund		10 E 1500 2230 30 300	0.00	0.00	0.00	0.00	0.00	0.00	0.00
Education Fund		10 E 1500 2230 30 300	0.00	0.00	0.00	0.00	0.00	0.00	0.00
Education Fund		ATH/ACT	0.00	0.00	0.00	0.00	0.00	0.00	0.00
Education Fund		ATH/ACT	1,527.30	128.46	0.00	0.00	418.68	1,108.62	72.59
Education Fund		ATH/ACT	516.84	40.26	0.00	0.00	169.38	347.46	67.23
Education Fund		ATH/ACT	0.00	0.00	0.00	0.00	-10.02	10.02	0.00
Education Fund		ATH/ACT	0.00	0.00	0.00	0.00	0.00	0.00	0.00
Education Fund		10 E 1500 2230 70 300	0.00	0.00	0.00	0.00	0.00	0.00	0.00
Education Fund		ATH/ACT	0.00	0.00	0.00	0.00	0.00	0.00	0.00
Education Fund		10 E 1500 2230 70 300	0.00	0.00	0.00	0.00	0.00	0.00	0.00
Education Fund		10 E 1500 2230 70 300	0.00	0.00	0.00	0.00	0.00	0.00	178 0.00
Education Fund		ATH/ACT	0.00	0.00	0.00	0.00	0.00	0.00	0.00
Education Fund	1150030030	GIRLS TRACK PUR SERV	0.00	0.00	0.00	0.00	0.00	0.00	0.00
Education Fund	1150030130	BOYS SOCCER PUR SERV	0.00	0.00	0.00	0.00	0.00	0.00	0.00
Education Fund	1150030230	BOYS BASKETBALL PUR	0.00	0.00	0.00	0.00	0.00	0.00	0.00
Education Fund	1150030330	WRESTLING PUR SERV	0.00	0.00	0.00	0.00	0.00	0.00	0.00
Education Fund	1150030430	BOYS VOLLEYBALL PUR	0.00	0.00	0.00	0.00	0.00	0.00	0.00
Education Fund	1150030530	SOFTBALL PUR SERV	0.00	0.00	0.00	0.00	0.00	0.00	0.00
Education Fund	1150030630	CHEERLEADER PUR SERV	0.00	0.00	0.00	0.00	0.00	0.00	0.00
Education Fund	1150030730	GIRLS VOLLEYBALL PUR	0.00	0.00	0.00	0.00	0.00	0.00	0.00
Education Fund	1150030830	GIRLS BOWLING PUR	8,500.00	0.00	0.00	0.00	8,500.00	0.00	0.00
Education Fund	1150030930	GOLF PURCHASE SERV	6,000.00	0.00	0.00	0.00	6,000.00	0.00	0.00
Education Fund	1150031030	CROSS COUNTRY PUR	0.00	0.00	0.00	0.00	0.00	0.00	0.00
Education Fund	1150031130	GIRLS BASKETBALL PUR	0.00	0.00	0.00	0.00	0.00	0.00	0.00

## Expenditure Report

Fiscal Year: 2023-2024  
Month: March

COUNTY OF GRUNDY SCHOOL DIST 111

Fund Description	Account	Account Description	Revised Budget	MTD Activity	Encumbrance	Pending Activity	Available Funds	Year to Date Activity	Percent of Budget Used
Education Fund	1150031230	BASEBALL PUR SERV	8,000.00	0.00	0.00	0.00	8,000.00	0.00	0.00
Education Fund	1150031330	GIRLS TENNIS PUR SERV	0.00	0.00	0.00	0.00	0.00	0.00	0.00
Education Fund	1150031430	POMS PUR SERV	1,200.00	0.00	0.00	0.00	1,200.00	0.00	0.00
Education Fund	1150031530	FOOTBALL PUR SERV	25,000.00	0.00	0.00	0.00	-734.61	25,734.61	102.94
Education Fund	1150031630	BOYS TRACK PUR SERV	0.00	0.00	0.00	0.00	0.00	0.00	0.00
Education Fund	1150031730	GIRLS SOCCER PUR SERV	0.00	0.00	0.00	0.00	0.00	0.00	0.00
Education Fund	1150032130	GEN ATHLETIC PUR SERV	0.00	0.00	0.00	0.00	0.00	0.00	0.00
Education Fund	1150033330	SUMMER BASEBALL PUR	0.00	0.00	0.00	0.00	0.00	0.00	0.00
Education Fund	1150033630	ATH TRAINER PUR SERV	0.00	0.00	0.00	0.00	0.00	0.00	0.00
Education Fund	1150033730	BOYS BOWLING PUR SERV	8,500.00	7,326.75	0.00	0.00	1,173.25	7,326.75	86.20
Education Fund	1150039330	BOYS TENNIS PUR SERV	0.00	0.00	0.00	0.00	0.00	0.00	179 0.00
Education Fund	1150039530	SWIMMING PUR SERVICE	30,000.00	0.00	0.00	0.00	17,556.00	12,444.00	41.48
Education Fund		GIRLS GOLF PURCH SERV	0.00	0.00	0.00	0.00	0.00	0.00	0.00
Education Fund		GIRLS WRESTLING PUR	0.00	0.00	0.00	0.00	0.00	0.00	0.00
Education Fund	1150031370	THESPIAN THEATRE FEST	0.00	0.00	0.00	0.00	-1,875.00	1,875.00	0.00
Education Fund	1150032170	FFA	0.00	0.00	0.00	0.00	0.00	0.00	0.00
Education Fund	1150030070	MUSICAL PUR SERV	11,000.00	53.12	0.00	50.00	1,507.95	9,442.05	85.84
Education Fund	1150030170	FALL PLAY PUR SERV	3,000.00	0.00	0.00	0.00	19.55	2,980.45	99.35
Education Fund	1150030270	STUDENT ACT PUR SERV	2,500.00	0.00	0.00	0.00	2,284.12	215.88	8.64
Education Fund	1150030370	NEWSPAPER PUR SERV	5,000.00	749.00	0.00	0.00	2,082.00	2,918.00	58.36
Education Fund	1150030470	CHILDRENS THEATRE PUR	1,500.00	0.00	0.00	0.00	1,159.00	341.00	22.73
Education Fund	1150030570	INTL CLUB PUR SERV	0.00	0.00	0.00	0.00	0.00	0.00	0.00
Education Fund	1150030670	WINTERGUARD PUR SERV	2,000.00	0.00	0.00	0.00	0.00	2,000.00	100.00
Education Fund	1150030770	NHS PUR SERV	0.00	0.00	0.00	0.00	0.00	0.00	0.00

## Expenditure Report

Fiscal Year: 2023-2024  
Month: March

COUNTY OF GRUNDY SCHOOL DIST 111

Fund Description	Account	Account Description	Revised Budget	MTD Activity	Encumbrance	Pending Activity	Available Funds	Year to Date Activity	Percent of Budget Used
Education Fund	1150030870	FFA PUR SERV	0.00	0.00	0.00	0.00	0.00	0.00	0.00
Education Fund	1150031070	BOOK CLUB SPEAKER	250.00	0.00	0.00	0.00	250.00	0.00	0.00
Education Fund	1150031670	MINOOKA ANGLERS	1,200.00	0.00	0.00	0.00	1,200.00	0.00	0.00
Education Fund	1150032070	FBLA	0.00	0.00	0.00	0.00	0.00	0.00	0.00
Education Fund	1150032270	FOOTBALL CLEANUP	1,200.00	0.00	0.00	0.00	0.00	1,200.00	100.00
Education Fund	1150032370	REVTRAK ACTIVITY	52,000.00	0.00	0.00	0.00	43,570.00	8,430.00	16.21
Education Fund	1150031930	GIRLS VOLLEYBALL	3,500.00	0.00	0.00	0.00	-1,413.00	4,913.00	140.37
Education Fund	1150032030	BOYS SOCCER OFFICIAL	3,750.00	0.00	0.00	0.00	-18.00	3,768.00	100.48
Education Fund	1150032230	SOFTBALL OFFICIAL	5,000.00	154.00	0.00	154.00	4,550.00	296.00	5.92
Education Fund	1150032330	FOOTBALL OFFICIAL	6,200.00	0.00	509.00	0.00	19.00	5,672.00	91.48
Education Fund	1150032430	BOYS BASKETBALL	7,000.00	0.00	0.00	0.00	826.00	6,174.00	18088.20
Education Fund	1150032530	GIRLS BASKETBALL	6,500.00	0.00	0.00	0.00	1,516.00	4,984.00	76.68
Education Fund	1150032630	BOYS WRESTLING	2,700.00	0.00	0.00	0.00	267.00	2,433.00	90.11
Education Fund	1150032730	BASEBALL OFFICIALS	6,700.00	372.00	146.00	154.00	6,028.00	372.00	5.55
Education Fund	1150032830	CROSS COUNTRY	1,000.00	0.00	0.00	0.00	164.00	836.00	83.60
Education Fund	1150032930	BOYS VOLLEYBALL	3,500.00	0.00	0.00	248.00	3,252.00	0.00	0.00
Education Fund	1150033030	GIRLS TRACK OFFICIAL	1,200.00	462.00	0.00	0.00	738.00	462.00	38.50
Education Fund	1150033130	BOYS TRACK OFFICIAL	1,600.00	616.00	0.00	0.00	964.32	635.68	39.73
Education Fund	1150033230	GIRLS SOCCER OFFICIAL	2,500.00	154.00	82.00	825.00	1,439.00	154.00	6.16
Education Fund	1150033830	INVITATIONAL OFFICIALS	0.00	0.00	0.00	0.00	-2,616.25	2,616.25	0.00
Education Fund	1150033930	LACROSSE OFFICIALS	3,000.00	304.00	0.00	0.00	2,547.00	453.00	15.10
Education Fund		GIRLS WRESTLING	1,200.00	0.00	0.00	0.00	-2,950.00	4,150.00	345.83
Education Fund	1150031970	STUDENT ACT	2,000.00	0.00	0.00	0.00	1,405.00	595.00	29.75
Education Fund	1150031830	ATHLETIC TOWEL	0.00	0.00	0.00	0.00	0.00	0.00	0.00

## Expenditure Report

Fiscal Year: 2023-2024  
Month: March

COUNTY OF GRUNDY SCHOOL DIST 111

Fund Description	Account	Account Description	Revised Budget	MTD Activity	Encumbrance	Pending Activity	Available Funds	Year to Date Activity	Percent of Budget Used
Education Fund	1150033430	GENERAL ATHLETIC	2,000.00	0.00	0.00	0.00	2,000.00	0.00	0.00
Education Fund	1150033530	ATHLETIC DIRECTOR	2,000.00	268.80	150.96	0.00	1,418.74	430.30	21.52
Education Fund	1150033270	STUDENT ACT/TRAVEL	14,000.00	3,402.26	0.00	0.00	7,293.02	6,706.98	47.91
Education Fund	1150033570	ACTIVITY DIRECTOR	1,000.00	263.95	0.00	0.00	450.61	549.39	54.94
Education Fund	1150039030	GEN ATHLETIC	62,000.00	720.00	629.90	350.00	9,529.48	51,490.62	83.05
Education Fund	1150039430	GEN ATHLETIC POST	55,000.00	12,586.25	0.00	0.00	-8,980.01	63,980.01	116.33
Education Fund	1150139030	GATE RECEIPTS CASH	0.00	0.00	0.00	0.00	0.00	0.00	0.00
Education Fund	1150041030	BOYS WRESTLING	7,000.00	0.00	120.00	0.00	2,091.00	4,789.00	68.41
Education Fund	1150041130	GIRLS TENNIS SUPPLIES	1,000.00	0.00	0.00	0.00	2.98	997.02	99.70
Education Fund	1150041230	BOYS TENNIS SUPPLIES	1,000.00	0.00	997.00	0.00	3.00	0.00	0.00
Education Fund	1150041330	CROSS COUNTRY	1,500.00	0.00	0.00	0.00	278.00	1,222.00	181.47
Education Fund	1150041430	CHEERLEADER SUPPLIES	3,000.00	0.00	0.00	0.00	2,680.40	319.60	10.65
Education Fund	1150041530	BOYS GOLF SUPPLIES	4,000.00	0.00	0.00	0.00	4,000.00	0.00	0.00
Education Fund	1150041630	BOYS TRACK SUPPLIES	2,000.00	0.00	0.00	0.00	12.60	1,987.40	99.37
Education Fund	1150041730	GIRLS TRACK SUPPLIES	2,000.00	1,944.00	0.00	0.00	56.00	1,944.00	97.20
Education Fund	1150041830	GEN ATHLETIC SUPPLIES	10,000.00	0.00	252.99	0.00	6,187.55	3,559.46	35.59
Education Fund	1150041930	GIRLS SOCCER SUPPLIES	3,300.00	0.00	690.00	0.00	6.77	2,603.23	78.89
Education Fund	1150042030	BASEBALL SUPPLIES	5,000.00	642.00	760.00	0.00	-82.00	4,322.00	86.44
Education Fund	1150042130	SOFTBALL SUPPLIES	5,000.00	0.00	3,920.00	0.00	920.02	159.98	3.20
Education Fund	1150042230	BOYS VOLLEYBALL	2,000.00	0.00	0.00	0.00	167.00	1,833.00	91.65
Education Fund	1150042330	GIRLS VOLLEYBALL	2,000.00	0.00	0.00	0.00	290.24	1,709.76	85.49
Education Fund	1150042430	GIRLS BASKETBALL	1,400.00	0.00	850.00	0.00	539.17	10.83	0.77
Education Fund	1150042530	BOYS SOCCER SUPPLIES	2,500.00	0.00	636.25	0.00	1.70	1,862.05	74.48
Education Fund	1150042630	BOYS BASKETBALL	1,400.00	0.00	0.00	0.00	1,375.66	24.34	1.74

## Expenditure Report

Fiscal Year: 2023-2024  
Month: March

COUNTY OF GRUNDY SCHOOL DIST 111

Fund Description	Account	Account Description	Revised Budget	MTD Activity	Encumbrance	Pending Activity	Available Funds	Year to Date Activity	Percent of Budget Used
Education Fund	1150042730	ATHLETIC DIRECTOR	4,000.00	750.00	0.00	0.00	1,757.51	2,242.49	56.06
Education Fund	1150042830	FOOTBALL SUPPLIES	44,000.00	0.00	12,802.00	0.00	-8,604.85	39,802.85	90.46
Education Fund	1150042930	GIRLS BOWLING SUPPLIES	500.00	0.00	0.00	0.00	500.00	0.00	0.00
Education Fund	1150043030	POMS SUPPLIES	2,500.00	0.00	0.00	0.00	2,500.00	0.00	0.00
Education Fund	1150043130	ATHLETIC AWARD	27,000.00	5,691.60	1,020.00	2,540.00	7,837.40	15,602.60	57.79
Education Fund	1150043230	GIRLS GOLF SUPPLIES	3,700.00	0.00	0.00	0.00	445.68	3,254.32	87.95
Education Fund	1150043330	SUMMER BASEBALL	1,400.00	0.00	0.00	0.00	1,400.00	0.00	0.00
Education Fund	1150043430	BOYS BOWLING SUPPLIES	500.00	0.00	0.00	0.00	500.00	0.00	0.00
Education Fund	1150043530	ATHLETIC COMP TECH	500.00	0.00	0.00	0.00	500.00	0.00	0.00
Education Fund	1150043630	BOYS LACROSSE	4,000.00	970.84	0.00	0.00	1,989.16	2,010.84	50.27
Education Fund	1150044030	BOYS GOLF UNIFORMS	4,000.00	0.00	0.00	0.00	4,000.00	0.00	182 0.00
Education Fund	1150044130	GIRLS GOLF UNIFORMS	4,000.00	0.00	0.00	0.00	4,000.00	0.00	0.00
Education Fund	1150044230	GIRLS TENNIS UNIFORMS	2,000.00	0.00	0.00	0.00	2,000.00	0.00	0.00
Education Fund	1150044330	BOYS BOWLING	0.00	0.00	0.00	0.00	0.00	0.00	0.00
Education Fund	1150044430	GIRLS BOWLING	0.00	0.00	0.00	0.00	0.00	0.00	0.00
Education Fund	1150044530	BOYS WRESTLING	0.00	0.00	0.00	0.00	0.00	0.00	0.00
Education Fund	1150044630	BOYS TRACK UNIFORMS	2,000.00	409.34	1,556.00	0.00	34.66	409.34	20.47
Education Fund	1150044730	GIRLS TRACK UNIFORMS	2,000.00	0.00	1,987.50	0.00	12.50	0.00	0.00
Education Fund	1150044830	BOYS TENNIS UNIFORMS	2,000.00	0.00	0.00	0.00	1,241.84	758.16	37.91
Education Fund	1150044930	BASEBALL UNIFORMS	4,400.00	0.00	0.00	0.00	816.00	3,584.00	81.45
Education Fund	1150045030	SOFTBALL UNIFORMS	4,400.00	0.00	0.00	0.00	4,400.00	0.00	0.00
Education Fund	1150045130	GIRLS BASKETBALL	2,800.00	0.00	0.00	0.00	2,381.00	419.00	14.96
Education Fund	1150045230	BOYS SOCCER UNIFORMS	3,000.00	0.00	0.00	0.00	54.00	2,946.00	98.20
Education Fund	1150045330	GIRLS VOLLEYBALL	2,500.00	0.00	0.00	0.00	157.00	2,343.00	93.72

## Expenditure Report

Fiscal Year: 2023-2024  
Month: March

COUNTY OF GRUNDY SCHOOL DIST 111

Fund Description	Account	Account Description	Revised Budget	MTD Activity	Encumbrance	Pending Activity	Available Funds	Year to Date Activity	Percent of Budget Used
Education Fund	1150045430	CROSS COUNTRY	2,200.00	0.00	0.00	0.00	83.08	2,116.92	96.22
Education Fund	1150045530	POMS UNIFORMS	6,700.00	0.00	0.00	0.00	-1,300.00	8,000.00	119.40
Education Fund	1150045630	BOYS BASKETBALL	0.00	0.00	0.00	0.00	0.00	0.00	0.00
Education Fund	1150045730	BOYS VOLLEYBALL	2,500.00	0.00	0.00	0.00	2,500.00	0.00	0.00
Education Fund	1150045830	GIRLS SOCCER UNIFORMS	2,500.00	0.00	0.00	0.00	2,500.00	0.00	0.00
Education Fund	1150045930	FOOTBALL UNIFORMS	0.00	0.00	40,000.00	0.00	-40,000.00	0.00	0.00
Education Fund	1150046030	CHEERLEADING	8,500.00	0.00	0.00	0.00	-1,406.12	9,906.12	116.54
Education Fund	1150046130	BOYS LACROSSE	4,000.00	0.00	0.00	0.00	-320.00	4,320.00	108.00
Education Fund	1150141030	ATHLETIC TRAINER	6,000.00	0.00	0.00	0.00	5,693.17	306.83	5.11
Education Fund		GIRLS WRESTLING	7,000.00	0.00	0.00	0.00	640.17	6,359.83	90.85
Education Fund		GIRLS WRESTLING	3,000.00	0.00	1,387.00	0.00	43.00	1,570.00	18352.33
Education Fund		GIRLS LACROSSE	4,000.00	0.00	0.00	0.00	4,000.00	0.00	0.00
Education Fund		GIRLS LACROSSE	4,000.00	0.00	0.00	0.00	4,000.00	0.00	0.00
Education Fund	1150042970	YEARBOOK SUPPLIES	1,000.00	0.00	0.00	0.00	37.21	962.79	96.28
Education Fund	1150041070	NEWSPAPER SUPPLIES	500.00	0.00	0.00	0.00	500.00	0.00	0.00
Education Fund	1150041170	SPEECH SUPPLIES	500.00	0.00	0.00	0.00	500.00	0.00	0.00
Education Fund	1150041270	KALEIDOSCOPE SUPPLIES	100.00	0.00	0.00	0.00	100.00	0.00	0.00
Education Fund	1150041370	NHS SUPPLIES	1,500.00	77.56	0.00	0.00	1,131.29	368.71	24.58
Education Fund	1150041470	MUSICAL SUPPLIES	5,500.00	1,322.99	0.00	0.00	4,046.15	1,453.85	26.43
Education Fund	1150041570	FALL PLAY SUPPLIES	1,500.00	0.00	0.00	0.00	174.32	1,325.68	88.38
Education Fund	1150041670	STUDENT ACT SUPPLIES	2,000.00	140.00	41.01	58.51	307.79	1,592.69	79.63
Education Fund	1150041770	ACTIVITY OFFICE	600.00	0.00	64.52	0.00	18.41	517.07	86.18
Education Fund	1150041870	CHILDRENS THEATRE	1,000.00	0.00	0.00	0.00	1,000.00	0.00	0.00
Education Fund	1150041970	INTL CLUB SUPPLIES	0.00	0.00	0.00	0.00	0.00	0.00	0.00

## Expenditure Report

Fiscal Year: 2023-2024  
Month: March

COUNTY OF GRUNDY SCHOOL DIST 111

Fund Description	Account	Account Description	Revised Budget	MTD Activity	Encumbrance	Pending Activity	Available Funds	Year to Date Activity	Percent of Budget Used
Education Fund	1150042070	WINTERGUARD SUPPLIES	5,000.00	88.40	0.00	0.00	40.84	4,959.16	99.18
Education Fund	1150042170	BOOK CLUB AWARDS	100.00	0.00	0.00	0.00	100.00	0.00	0.00
Education Fund	1150042270	FBLA SUPPLIES	0.00	0.00	0.00	0.00	0.00	0.00	0.00
Education Fund	1150042370	FNHS INDUCTION	100.00	0.00	0.00	0.00	100.00	0.00	0.00
Education Fund	1150042470	INVESTMENT CLUB	100.00	0.00	0.00	0.00	0.88	99.12	99.12
Education Fund	1150042570	SPANISH NHS INDUCTION	100.00	0.00	0.00	0.00	100.00	0.00	0.00
Education Fund	1150042670	SADD/TATU SUPPLIES	200.00	0.00	0.00	0.00	115.83	84.17	42.09
Education Fund	1150042870	SCHOLASTIC BOWL	100.00	0.00	0.00	0.00	100.00	0.00	0.00
Education Fund	1150043170	MADRIGAL SUPPLIES	0.00	0.00	0.00	0.00	0.00	0.00	0.00
Education Fund	1150043370	SENIOR MURAL	250.00	0.00	0.00	0.00	250.00	0.00	0.00
Education Fund	1150043470	COLOR PAPER SUPPLIES	500.00	0.00	0.00	0.00	500.00	0.00	184 0.00
Education Fund	1150043670	ACTIVITY P-CARD ORDERS	3,000.00	0.00	0.00	0.00	5,697.62	-2,697.62	-89.92
Education Fund	1150043770	INTL THESPIAN SUPPLIES	500.00	0.00	0.00	0.00	500.00	0.00	0.00
Education Fund	1150043870	CHESS TEAM SUPPLIES	100.00	0.00	0.00	0.00	13.45	86.55	86.55
Education Fund	1150043970	PAC SOUND ROOM	12,000.00	267.79	0.00	0.00	8,912.58	3,087.42	25.73
Education Fund		CONNECTIONS CREW	1,500.00	363.98	0.00	0.00	698.34	801.66	53.44
Education Fund	1150043070	STUDENT ACT	0.00	0.00	0.00	0.00	0.00	0.00	0.00
Education Fund	1150054030	GIRLS TRACK EQUIPMENT	3,000.00	70.10	2,747.90	0.00	182.00	70.10	2.34
Education Fund	1150054130	BOYS TENNIS EQUIPMENT	0.00	0.00	0.00	0.00	0.00	0.00	0.00
Education Fund	1150054230	FOOTBALL EQUIPMENT	0.00	0.00	0.00	0.00	0.00	0.00	0.00
Education Fund	1150054330	GIRLS TENNIS EQUIPMENT	0.00	0.00	0.00	0.00	0.00	0.00	0.00
Education Fund	1150054430	BOYS TRACK EQUIPMENT	3,000.00	395.00	2,420.30	0.00	184.70	395.00	13.17
Education Fund	1150054530	GENERAL ATHLETIC	20,000.00	8,160.60	267.00	0.00	2,902.05	16,830.95	84.15
Education Fund	1150054630	BASEBALL EQUIPMENT	0.00	0.00	0.00	0.00	0.00	0.00	0.00

## Expenditure Report

Fiscal Year: 2023-2024  
Month: March

COUNTY OF GRUNDY SCHOOL DIST 111

Fund Description	Account	Account Description	Revised Budget	MTD Activity	Encumbrance	Pending Activity	Available Funds	Year to Date Activity	Percent of Budget Used
Education Fund	1150054730	BOYS GOLF EQUIPMENT	0.00	0.00	0.00	0.00	0.00	0.00	0.00
Education Fund	1150054830	GIRLS VOLLEYBALL	0.00	0.00	0.00	0.00	0.00	0.00	0.00
Education Fund	1150054930	BOYS VOLLEYBALL	0.00	0.00	0.00	0.00	0.00	0.00	0.00
Education Fund	1150055030	BOYS BASKETBALL	0.00	0.00	0.00	0.00	0.00	0.00	0.00
Education Fund	1150055130	SOFTBALL EQUIPMENT	0.00	0.00	0.00	0.00	0.00	0.00	0.00
Education Fund	1150055230	WRESTLING EQUIPMENT	0.00	0.00	0.00	0.00	0.00	0.00	0.00
Education Fund	1150055330	GIRLS BASKETBALL	0.00	0.00	0.00	0.00	0.00	0.00	0.00
Education Fund	1150055430	CROSS COUNTRY	0.00	0.00	0.00	0.00	0.00	0.00	0.00
Education Fund	1150055530	GIRLS BOWLING	0.00	0.00	0.00	0.00	0.00	0.00	0.00
Education Fund	1150055630	BOYS SOCCER	0.00	0.00	0.00	0.00	0.00	0.00	0.00
Education Fund	1150055730	ATHLETIC DIRECTOR	0.00	0.00	0.00	0.00	0.00	0.00	185 0.00
Education Fund	1150055830	GIRLS SOCCER	0.00	0.00	0.00	0.00	0.00	0.00	0.00
Education Fund	1150055930	POMS EQUIPMENT	0.00	0.00	0.00	0.00	0.00	0.00	0.00
Education Fund	1150056030	GIRLS GOLF EQUIPMENT	0.00	0.00	0.00	0.00	0.00	0.00	0.00
Education Fund	1150056130	CHEERLEADER	0.00	0.00	0.00	0.00	0.00	0.00	0.00
Education Fund	1150056230	BOYS BOWLING	0.00	0.00	0.00	0.00	0.00	0.00	0.00
Education Fund	1150056330	SUMMER BASEBALL	0.00	0.00	0.00	0.00	0.00	0.00	0.00
Education Fund	1150056430	LACROSSE EQUIPMENT	0.00	0.00	0.00	0.00	0.00	0.00	0.00
Education Fund	1150154030	ATHLETIC TRAINER	5,000.00	0.00	0.00	0.00	5,000.00	0.00	0.00
Education Fund	1150054070	STUDENT ACT EQUIPMENT	0.00	0.00	0.00	0.00	0.00	0.00	0.00
Education Fund	1150054170	MAIN OFFICE EQUIPMENT	0.00	0.00	0.00	0.00	0.00	0.00	0.00
Education Fund	1150054270	WINTERGUARD	0.00	0.00	0.00	0.00	0.00	0.00	0.00
Education Fund	1150054370	PAC SOUND ROOM	20,775.00	0.00	956.20	0.00	16,488.53	3,330.27	16.03
Education Fund	1150039130	GEN ATHLETIC CLINICS	5,500.00	0.00	0.00	0.00	4,089.00	1,411.00	25.65

## Expenditure Report

Fiscal Year: 2023-2024  
Month: March

COUNTY OF GRUNDY SCHOOL DIST 111

Fund Description	Account	Account Description	Revised Budget	MTD Activity	Encumbrance	Pending Activity	Available Funds	Year to Date Activity	Percent of Budget Used
Education Fund	1150039230	ATHLETIC DIRECTOR	500.00	0.00	0.00	0.00	500.00	0.00	0.00
Education Fund	1150064030	ATHLETIC DUES/FEES	5,000.00	0.00	0.00	0.00	3,513.20	1,486.80	29.74
Education Fund	1150064570	TSA FEES	0.00	0.00	0.00	0.00	0.00	0.00	0.00
Education Fund	1150064970	FNHS DUES	0.00	0.00	0.00	0.00	0.00	0.00	0.00
Education Fund	1150039070	SPEECH ENTRY FEES	1,000.00	0.00	0.00	0.00	500.00	500.00	50.00
Education Fund	1150064070	SPEECH DUES/FEES	0.00	0.00	0.00	0.00	0.00	0.00	0.00
Education Fund	1150064170	STUDENT ACT	2,500.00	0.00	0.00	0.00	1,880.33	619.67	24.79
Education Fund	1150064270	ICTM REGIONAL/ORAL	300.00	0.00	0.00	0.00	0.00	300.00	100.00
Education Fund	1150064370	WYSE REGISTRATION	300.00	0.00	0.00	0.00	225.00	75.00	25.00
Education Fund	1150064470	FBLA COMPETITION FEES	0.00	0.00	0.00	0.00	0.00	0.00	0.00
Education Fund	1150064670	SPANISH NHS	100.00	0.00	0.00	0.00	100.00	0.00	186 0.00
Education Fund	1150064770	JOURNALISM FEES/STATE	500.00	0.00	0.00	0.00	500.00	0.00	0.00
Education Fund	1150064870	FFA	0.00	0.00	0.00	0.00	0.00	0.00	0.00
Education Fund	1150065170	WINTERGUARD CIRCUIT	3,100.00	0.00	0.00	0.00	40.00	3,060.00	98.71
Education Fund	1150065270	INDOOR PERCUSSION	1,500.00	300.00	0.00	0.00	-180.00	1,680.00	112.00
Education Fund	11600110	SUMMER SCHOOL SALARY	0.00	0.00	0.00	0.00	0.00	0.00	0.00
Education Fund	11600211	SUMMER SCHOOL TRS	0.00	0.00	0.00	0.00	0.00	0.00	0.00
Education Fund	10-1600-	SUMMER SCHOOL SALARY	0.00	0.00	0.00	0.00	0.00	0.00	0.00
Education Fund	11650390	GIFTED PUR SERV	0.00	0.00	0.00	0.00	0.00	0.00	0.00
Education Fund	11650410	GIFTED SUPPLIES	0.00	0.00	0.00	0.00	0.00	0.00	0.00
Education Fund	11650540	GIFTED EQUIPMENT	0.00	0.00	0.00	0.00	0.00	0.00	0.00
Education Fund	11700110	DRIVER ED SALARY	463,910.16	39,055.18	0.00	0.00	114,263.43	349,646.73	75.37
Education Fund	11700111	SUMMER DR ED SALARY	33,920.00	0.00	0.00	0.00	31,977.20	1,942.80	5.73
Education Fund	11700211	SUMMER DR ED TRS	4,049.21	0.00	0.00	0.00	3,816.02	233.19	5.76

## Expenditure Report

Fiscal Year: 2023-2024  
Month: March

COUNTY OF GRUNDY SCHOOL DIST 111

Fund Description	Account	Account Description	Revised Budget	MTD Activity	Encumbrance	Pending Activity	Available Funds	Year to Date Activity	Percent of Budget Used
Education Fund	1170021121	DRIVER ED TRS	55,682.40	4,687.75	0.00	0.00	13,714.72	41,967.68	75.37
Education Fund	11700222	DR ED INS	0.00	0.00	0.00	0.00	0.00	0.00	0.00
Education Fund	10-1700-	DRIVER ED MEDICAL INS	109,450.97	9,002.14	0.00	0.00	30,991.29	78,459.68	71.68
Education Fund		DRIVER ED DENTAL INS	3,101.04	201.30	0.00	0.00	1,288.18	1,812.86	58.46
Education Fund	1170030021	DRIVERS ED CONT SERV	0.00	0.00	0.00	0.00	0.00	0.00	0.00
Education Fund	1170030021	DRIVERS ED CONT SERV S	0.00	0.00	0.00	0.00	0.00	0.00	0.00
Education Fund	11700323	DRIVERS ED	14,000.00	1,209.54	0.00	0.00	7,986.63	6,013.37	42.95
Education Fund	1170038021	DRIVER ED CAR INS	0.00	0.00	0.00	0.00	0.00	0.00	0.00
Education Fund	1170041021	DRIVERS ED SUPPLIES	2,000.00	0.00	0.00	0.00	2,191.09	-191.09	-9.55
Education Fund	1170041021	DRIVERS ED SUPPLIES S	0.00	0.00	0.00	0.00	0.00	0.00	0.00
Education Fund	1170041121	DR ED COMP TECH	0.00	0.00	0.00	0.00	0.00	0.00	187 0.00
Education Fund	1170042021	DRIVERS ED TEXTBOOKS	0.00	0.00	0.00	0.00	0.00	0.00	0.00
Education Fund	1170042021	DRIVERS ED TEXTBOOKS	0.00	0.00	0.00	0.00	0.00	0.00	0.00
Education Fund	11700464	DR ED GAS	7,500.00	560.11	0.00	57.14	3,764.77	3,678.09	49.04
Education Fund	1170049021	DRIVERS ED	0.00	0.00	0.00	0.00	0.00	0.00	0.00
Education Fund	1170049021	DRIVERS ED	0.00	0.00	0.00	0.00	0.00	0.00	0.00
Education Fund	1170054021	DRIVERS ED EQUIPMENT	0.00	0.00	0.00	0.00	0.00	0.00	0.00
Education Fund	1170054021	DRIVERS ED EQUIPMENT	0.00	0.00	0.00	0.00	0.00	0.00	0.00
Education Fund	1170055021	DRIVERS ED VEHICLES	0.00	0.00	0.00	0.00	0.00	0.00	0.00
Education Fund	1170064021	DRIVERS ED	0.00	0.00	0.00	0.00	0.00	0.00	0.00
Education Fund	1170064021	DRIVERS ED	0.00	0.00	0.00	0.00	0.00	0.00	0.00
Education Fund	11800110	ELL INSTRUCTION	0.00	0.00	0.00	0.00	0.00	0.00	0.00
Education Fund	11800211	ELL TRS	0.00	0.00	0.00	0.00	0.00	0.00	0.00
Education Fund	11900110	MINOOKA ACADEMY DIR	112,165.20	9,347.10	0.00	0.00	28,863.51	83,301.69	74.27

## Expenditure Report

Fiscal Year: 2023-2024  
Month: March

COUNTY OF GRUNDY SCHOOL DIST 111

Fund Description	Account	Account Description	Revised Budget	MTD Activity	Encumbrance	Pending Activity	Available Funds	Year to Date Activity	Percent of Budget Used
Education Fund	11900112	MINOOKA ACADEMY AIDE	37,096.08	3,091.34	0.00	0.00	9,624.68	27,471.40	74.05
Education Fund	11900211	MINOOKA ACADEMY TRS	13,463.04	1,121.92	0.00	0.00	3,464.45	9,998.59	74.27
Education Fund	11900222	MINOOKA ACADEMY	37,644.55	1,972.40	0.00	0.00	27,050.59	10,593.96	28.14
Education Fund		MINOOKA ACADEMY AIDE	21,985.60	2,009.66	0.00	0.00	4,856.98	17,128.62	77.91
Education Fund		MINOOKA ACADEMY	516.84	40.26	0.00	0.00	169.38	347.46	67.23
Education Fund	11900390	MINOOKA ACADEMY PUR	500.00	0.00	0.00	0.00	500.00	0.00	0.00
Education Fund	11900332	MINOOKA ACADEMY	0.00	0.00	0.00	0.00	0.00	0.00	0.00
Education Fund	11900410	MINOOKA ACADEMY	500.00	0.00	0.00	0.00	500.00	0.00	0.00
Education Fund	11900411	MINOOKA ACADEMY COMP	0.00	0.00	0.00	0.00	0.00	0.00	0.00
Education Fund	11900420	MINOOKA ACADEMY	0.00	0.00	0.00	0.00	0.00	0.00	0.00
Education Fund	11900540	MINOOKA ACADEMY	0.00	0.00	0.00	0.00	0.00	0.00	188 0.00
Education Fund	11900640	MINOOKA ACADEMY	0.00	0.00	0.00	0.00	0.00	0.00	0.00
Education Fund	11912670	SPECIAL EDUCATION	2,000,000.00	212,242.85	0.00	53,500.32	248,163.22	1,698,336.46	84.92
Education Fund	12100112	ASST PRIN-LEARNING	0.00	0.00	0.00	0.00	0.00	0.00	0.00
Education Fund	12100113	MAIN OFFICE SECY	40,323.08	3,429.54	0.00	0.00	10,600.04	29,723.04	73.71
Education Fund	12100110	DIRECTOR STUDENT	141,991.44	11,832.62	0.00	0.00	35,497.86	106,493.58	75.00
Education Fund	12100111	DIR OF STUDENT SERV	0.00	0.00	0.00	0.00	0.00	0.00	0.00
Education Fund	12100120	SUMMER MAIN OFFICE	0.00	0.00	0.00	0.00	0.00	0.00	0.00
Education Fund	12100211	DIR OF STUDENT SERV	0.00	0.00	0.00	0.00	0.00	0.00	0.00
Education Fund	121002111	ASST PRIN-LEARNING TRS	0.00	0.00	0.00	0.00	0.00	0.00	0.00
Education Fund	10-2100-	DIRECTOR STUDENT SERV	17,397.85	1,449.82	0.00	0.00	4,349.43	13,048.42	75.00
Education Fund	10-2100-	DIRECTOR STUDENT	0.00	0.00	0.00	0.00	0.00	0.00	0.00
Education Fund	12100222	MAIN OFFICE GROUP INS	0.00	0.00	0.00	0.00	0.00	0.00	0.00
Education Fund		RECEPTIONSIT GROUP	29,092.27	4.20	0.00	0.00	26,926.82	2,165.45	7.44

## Expenditure Report

Fiscal Year: 2023-2024  
Month: March

COUNTY OF GRUNDY SCHOOL DIST 111

Fund Description	Account	Account Description	Revised Budget	MTD Activity	Encumbrance	Pending Activity	Available Funds	Year to Date Activity	Percent of Budget Used
Education Fund	12100223	DIRECTOR STUDENT	143.28	11.94	0.00	0.00	35.16	108.12	75.46
Education Fund		10 E 2100 2230 00 300	0.00	0.00	0.00	0.00	0.00	0.00	0.00
Education Fund	12100300	MAIN OFFICE PUR SERV	0.00	0.00	0.00	0.00	0.00	0.00	0.00
Education Fund	12100390	DIRECTOR STUDENT SERV	0.00	0.00	0.00	0.00	0.00	0.00	0.00
Education Fund	12100400	DIRECTOR STUDENT SERV	0.00	0.00	0.00	0.00	0.00	0.00	0.00
Education Fund	12100410	MAIN OFFICE SUPPLIES	0.00	0.00	0.00	0.00	0.00	0.00	0.00
Education Fund	12100540	MAIN OFFICE EQUIPMENT	0.00	0.00	0.00	0.00	0.00	0.00	0.00
Education Fund	12100640	CLINICS/WORKSHOPS	0.00	0.00	0.00	0.00	0.00	0.00	0.00
Education Fund	12100641	PROFESSIONAL DUES	0.00	0.00	0.00	0.00	0.00	0.00	0.00
Education Fund	12100642	DIR STUDENT SER	0.00	0.00	0.00	0.00	0.00	0.00	0.00
Education Fund	12100643	DIR STUDENT SERV	0.00	0.00	0.00	0.00	0.00	0.00	189 0.00
Education Fund	12110100	TITLE 1 SALARIES	39,196.43	1,260.00	0.00	0.00	11,396.00	27,800.43	70.93
Education Fund	10-2110-211	TITLE 1 SALARIES (IC)	571.43	284.77	0.00	0.00	-5,709.49	6,280.92	1,099.16
Education Fund	10-2110-222	TITLE 1 SALARIES (BMF 2)	1,656.75	0.00	0.00	0.00	0.00	1,656.75	100.00
Education Fund		TITLE I DENTAL INS	23.10	0.00	0.00	0.00	0.00	23.10	100.00
Education Fund		TITLE I SUPPLIES	10,000.00	0.00	0.00	0.00	158.46	9,841.54	98.42
Education Fund	12113110	SOCIAL WORKER SALARY	352,712.40	26,239.12	0.00	0.00	126,259.12	226,453.28	64.20
Education Fund	12113211	SOCIAL WORKER TRS	42,335.04	3,149.42	0.00	0.00	15,154.37	27,180.67	64.20
Education Fund	12113222	SOCIAL WORKERS GROUP	71,541.10	9,932.02	0.00	0.00	-8,739.46	80,280.56	112.22
Education Fund		SOCIAL WORKER DENTAL	2,380.90	161.04	0.00	0.00	1,051.94	1,328.96	55.82
Education Fund	12113390	SOCIAL WORKER PUR	0.00	0.00	0.00	0.00	0.00	0.00	0.00
Education Fund	121133902	SOCIAL WOKER CONT	0.00	0.00	0.00	0.00	0.00	0.00	0.00
Education Fund	12113332	SOCIAL WORKER	0.00	0.00	0.00	0.00	0.00	0.00	0.00
Education Fund	121133322	SOCIAL WORKER	0.00	0.00	0.00	0.00	0.00	0.00	0.00

## Expenditure Report

Fiscal Year: 2023-2024  
Month: March

COUNTY OF GRUNDY SCHOOL DIST 111

Fund Description	Account	Account Description	Revised Budget	MTD Activity	Encumbrance	Pending Activity	Available Funds	Year to Date Activity	Percent of Budget Used
Education Fund	12113410	SOCIAL WORKER	500.00	0.00	0.00	0.00	426.00	74.00	14.80
Education Fund	12113411	SOCIAL WKR COMP TECH	0.00	0.00	0.00	0.00	0.00	0.00	0.00
Education Fund	12113414	SOCIAL WORKER TESTING	0.00	0.00	0.00	0.00	0.00	0.00	0.00
Education Fund	121134102	SOCIAL WORKER	0.00	0.00	0.00	0.00	0.00	0.00	0.00
Education Fund	121134112	SOC WKR COMP TECK	0.00	0.00	0.00	0.00	0.00	0.00	0.00
Education Fund	121134142	SOCIAL WORKER TESTING	0.00	0.00	0.00	0.00	0.00	0.00	0.00
Education Fund	12113490	SOC WORKER	0.00	0.00	0.00	0.00	0.00	0.00	0.00
Education Fund	121134902	SOCIAL WORKER	0.00	0.00	0.00	0.00	0.00	0.00	0.00
Education Fund	12113640	SOC WORKER	0.00	0.00	0.00	0.00	0.00	0.00	0.00
Education Fund	121136402	SOCIAL WORKER	0.00	0.00	0.00	0.00	0.00	0.00	0.00
Education Fund	12120110	GUIDANCE SALARY	515,491.98	44,252.10	0.00	0.00	118,633.74	396,858.24	19076.99
Education Fund		ESSER III - GUIDANCE	6,325.02	0.00	0.00	0.00	-21.00	6,346.02	100.33
Education Fund	12120211	GUIDANCE TRS	63,161.92	5,311.58	0.00	0.00	15,812.76	47,349.16	74.96
Education Fund		ESSER TRS	1,356.67	0.00	0.00	0.00	-2.52	1,359.19	100.19
Education Fund	12120222	GUIDANCE GROUP INS	154,724.01	12,751.94	0.00	0.00	47,330.67	107,393.34	69.41
Education Fund		ESSER MEDICAL INS	1,299.00	0.00	0.00	0.00	0.00	1,299.00	100.00
Education Fund		GUIDANCE DENTAL INS	3,406.75	281.82	0.00	0.00	993.42	2,413.33	70.84
Education Fund		ESSER DENTAL INS	56.67	0.00	0.00	0.00	0.00	56.67	100.00
Education Fund	12120314	GUIDANCE PUR SERV	0.00	0.00	0.00	0.00	0.00	0.00	0.00
Education Fund	12120415	A.P. TESTING SERVICES	0.00	0.00	0.00	0.00	0.00	0.00	0.00
Education Fund	121203142	GUIDANCE CONT SERV S	0.00	0.00	0.00	0.00	0.00	0.00	0.00
Education Fund	121204152	A.P. TESTING SERVICES S	0.00	0.00	0.00	0.00	0.00	0.00	0.00
Education Fund	12120411	GUIDANCE COMP TECH	0.00	0.00	0.00	0.00	0.00	0.00	0.00
Education Fund	12120412	GUIDANCE SUPPLIES	4,000.00	0.00	0.00	0.00	3,060.95	939.05	23.48

## Expenditure Report

Fiscal Year: 2023-2024  
Month: March

COUNTY OF GRUNDY SCHOOL DIST 111

Fund Description	Account	Account Description	Revised Budget	MTD Activity	Encumbrance	Pending Activity	Available Funds	Year to Date Activity	Percent of Budget Used
Education Fund	12120414	GUIDANCE TESTING	0.00	0.00	0.00	0.00	0.00	0.00	0.00
Education Fund	1212041030	ALC SUPPLIES & S/W	0.00	0.00	0.00	0.00	0.00	0.00	0.00
Education Fund	121204112	GUIDANCE COMP TECH	0.00	0.00	0.00	0.00	0.00	0.00	0.00
Education Fund	121204122	GUIDANCE SUPPLIES S	0.00	0.00	0.00	0.00	-85.84	85.84	0.00
Education Fund	121204142	GUIDANCE TESTING S	0.00	0.00	0.00	0.00	0.00	0.00	0.00
Education Fund	12120420	GUIDANCE REF BOOKS	0.00	0.00	0.00	0.00	0.00	0.00	0.00
Education Fund	121204202	GUIDANCE REFERENCE	0.00	0.00	0.00	0.00	0.00	0.00	0.00
Education Fund	12120540	GUIDANCE EQUIPMENT	0.00	0.00	0.00	0.00	0.00	0.00	0.00
Education Fund	121205402	GUIDANCE EQUIPMENT S	0.00	0.00	0.00	0.00	0.00	0.00	0.00
Education Fund	12120640	GUIDANCE DUES	0.00	0.00	0.00	0.00	0.00	0.00	0.00
Education Fund	12120641	GUIDANCE	0.00	0.00	0.00	0.00	0.00	0.00	191 0.00
Education Fund	121206402	GUIDANCE DUES/FEES/LIT	0.00	0.00	0.00	0.00	0.00	0.00	0.00
Education Fund	121206412	GUIDANCE	0.00	0.00	0.00	0.00	0.00	0.00	0.00
Education Fund	12125110	REGISTRAR SALARY	55,044.62	4,119.38	0.00	0.00	15,143.66	39,900.96	72.49
Education Fund	12125111	ACADEMIC RESOURCE	50,767.20	4,230.60	0.00	0.00	13,329.30	37,437.90	73.74
Education Fund	12125112	ASST. REGISTRAR	38,629.50	3,219.12	0.00	0.00	9,657.42	28,972.08	75.00
Education Fund	12125211	CAREER CENTER TRS	0.00	0.00	0.00	0.00	0.00	0.00	0.00
Education Fund	12125222	REGISTRAR GROUP INS	32,517.67	2,944.46	0.00	0.00	7,424.89	25,092.78	77.17
Education Fund	12125223	CAREER CTR GROUP INS	32,359.68	2,931.26	0.00	0.00	7,386.06	24,973.62	77.18
Education Fund	10-2125-	ASST. REGISTRAR (BMF)	22,671.73	2,944.46	0.00	0.00	-1,918.89	24,590.62	108.46
Education Fund		REGISTRAR DENTAL INS	476.03	40.26	0.00	0.00	128.57	347.46	72.99
Education Fund		10 E 2125 2230 00 300	0.00	0.00	0.00	0.00	0.00	0.00	0.00
Education Fund		ASST. REGISTRAR DENTAL	0.00	40.26	0.00	0.00	-340.46	340.46	0.00
Education Fund	12125300	REGISTRAR PUR SERV	0.00	0.00	0.00	0.00	0.00	0.00	0.00

## Expenditure Report

Fiscal Year: 2023-2024  
Month: March

COUNTY OF GRUNDY SCHOOL DIST 111

Fund Description	Account	Account Description	Revised Budget	MTD Activity	Encumbrance	Pending Activity	Available Funds	Year to Date Activity	Percent of Budget Used
Education Fund	12125390	CAREER CTR PUR SERV	0.00	0.00	0.00	0.00	0.00	0.00	0.00
Education Fund	121253002	REGISTRAR CONT SERV S	5,000.00	461.42	0.00	0.00	-867.86	5,867.86	117.36
Education Fund	121253902	CAREER CTR CONT SERV	0.00	0.00	0.00	0.00	0.00	0.00	0.00
Education Fund	12125323	CAREER CTR	0.00	0.00	0.00	0.00	0.00	0.00	0.00
Education Fund	12125324	REGISTRAR REPAIR/MAINT	0.00	0.00	0.00	0.00	0.00	0.00	0.00
Education Fund	121253232	CAREER CTR	0.00	0.00	0.00	0.00	0.00	0.00	0.00
Education Fund	121253242	REGISTRAR REPAIR/MAINT	0.00	0.00	0.00	0.00	0.00	0.00	0.00
Education Fund	12125410	CAREER CENTER	0.00	0.00	0.00	0.00	0.00	0.00	0.00
Education Fund	121254101	CAREER CENTER COMP	0.00	0.00	0.00	0.00	0.00	0.00	0.00
Education Fund	12125411	REGISTRAR SUPPLIES	500.00	0.00	0.00	0.00	159.05	340.95	68.19
Education Fund	12125412	REGISTRAR COMP TECH	0.00	0.00	0.00	0.00	0.00	0.00	192 0.00
Education Fund	121254102	CAREER CTR SUPPLIES S	0.00	0.00	0.00	0.00	0.00	0.00	0.00
Education Fund	121254112	REGISTRAR SUPPLIES S	0.00	0.00	0.00	0.00	0.00	0.00	0.00
Education Fund	121254122	REGISTRAR COMP TECH	0.00	0.00	0.00	0.00	0.00	0.00	0.00
Education Fund	12125540	CAREER CTR EQUIPMENT	0.00	0.00	0.00	0.00	0.00	0.00	0.00
Education Fund	12125541	REGISTRAR EQUIPMENT	0.00	0.00	0.00	0.00	0.00	0.00	0.00
Education Fund	121255402	CAREER CTR EQUIPMENT	0.00	0.00	0.00	0.00	0.00	0.00	0.00
Education Fund	121255412	REGISTRAR EQUIPMENT S	0.00	0.00	0.00	0.00	0.00	0.00	0.00
Education Fund		IDEA - NURSE SUPPLIES	0.00	0.00	0.00	0.00	0.00	0.00	0.00
Education Fund		ARP - IDEA NURSE	0.00	0.00	0.00	0.00	0.00	0.00	0.00
Education Fund	12134110	NURSE SALARY	53,199.36	3,130.20	0.00	0.00	21,272.85	31,926.51	60.01
Education Fund	12134111	NURSE SALARY S.C.	74,043.12	8,690.65	0.00	0.00	11,250.83	62,792.29	84.81
Education Fund	12134211	NURSE TRS	0.00	0.00	0.00	0.00	0.00	0.00	0.00
Education Fund	10-2134-	NURSE SALARY S.C. (IC)	0.00	0.00	0.00	0.00	0.00	0.00	0.00

## Expenditure Report

Fiscal Year: 2023-2024  
Month: March

COUNTY OF GRUNDY SCHOOL DIST 111

Fund Description	Account	Account Description	Revised Budget	MTD Activity	Encumbrance	Pending Activity	Available Funds	Year to Date Activity	Percent of Budget Used
Education Fund	12134222	NURSE GROUP INS	55.44	4.20	0.00	0.00	17.64	37.80	68.18
Education Fund	10-2134-	NURSE SALARY S.C.	52.80	4.00	0.00	0.00	-1.19	53.99	102.25
Education Fund	12134300	NURSE PUR SERV	0.00	0.00	0.00	0.00	0.00	0.00	0.00
Education Fund	121343002	NURSE CONT SERV S	0.00	0.00	0.00	0.00	-28.80	28.80	0.00
Education Fund	12134323	NURSE REPAIR/MAINT	0.00	0.00	0.00	0.00	0.00	0.00	0.00
Education Fund	121343232	NURSE REPAIR/MAINT S	0.00	0.00	0.00	0.00	0.00	0.00	0.00
Education Fund	12134410	NURSE SUPPLIES	6,000.00	187.82	2,155.00	282.89	-2,061.00	5,623.11	93.72
Education Fund	12134411	NURSES SUPPLIES-BBP	0.00	0.00	0.00	0.00	0.00	0.00	0.00
Education Fund	12134412	NURSE COMP TECH	0.00	0.00	0.00	0.00	0.00	0.00	0.00
Education Fund	121344102	NURSE SUPPLIES S	750.00	0.00	0.00	216.72	166.00	367.28	48.97
Education Fund	121344112	NURSES SUPPLIES-BBP S	0.00	0.00	0.00	0.00	0.00	0.00	193 0.00
Education Fund	121344122	NURSE COMP TECH	0.00	0.00	0.00	0.00	0.00	0.00	0.00
Education Fund	12134420	RN REFERENCE BOOKS	0.00	0.00	0.00	0.00	0.00	0.00	0.00
Education Fund	121344202	NURSE REFERENCE	0.00	0.00	0.00	0.00	0.00	0.00	0.00
Education Fund	12134540	NURSE EQUIPMENT	0.00	0.00	0.00	0.00	0.00	0.00	0.00
Education Fund	121345402	NURSE EQUIPMENT S	0.00	0.00	0.00	0.00	0.00	0.00	0.00
Education Fund	12140110	PSYCHOLOGIST SALARY	178,653.84	13,544.84	0.00	0.00	56,845.90	121,807.94	68.18
Education Fund	10-2140-211	PSYCHOLOGIST TRS	21,443.52	1,625.76	0.00	0.00	6,823.12	14,620.40	68.18
Education Fund	12140222	PSYCHOLOGIST	100.80	8.40	0.00	0.00	25.20	75.60	75.00
Education Fund	12140400	PSYCHOLOGIST SUPPLIES	0.00	0.00	0.00	0.00	0.00	0.00	0.00
Education Fund	12142300	PSYCHOLOGICAL	0.00	0.00	0.00	0.00	0.00	0.00	0.00
Education Fund	10-2190-	CSBO SALARY (BIMRF)	0.00	0.00	0.00	0.00	0.00	0.00	0.00
Education Fund		TITLE II SALARIES	0.00	570.00	0.00	0.00	-4,425.00	4,425.00	0.00
Education Fund	12210110	DIRECTOR C/I SALARY	137,800.00	11,483.34	0.00	0.00	34,449.94	103,350.06	75.00

# Expenditure Report

Fiscal Year: 2023-2024  
Month: March

COUNTY OF GRUNDY SCHOOL DIST 111

Fund Description	Account	Account Description	Revised Budget	MTD Activity	Encumbrance	Pending Activity	Available Funds	Year to Date Activity	Percent of Budget Used
Education Fund	12210112	PROF. DEVELOPMENT	0.00	0.00	0.00	0.00	0.00	0.00	0.00
Education Fund	12210113	SPECIAL ED TEACHERS -	0.00	0.00	0.00	0.00	0.00	0.00	0.00
Education Fund	122101173	Title II Salaries	17,600.00	0.00	0.00	0.00	17,399.80	200.20	1.14
Education Fund	12210111	DIR C/I SEC. SALARY	37,459.50	3,121.62	0.00	0.00	9,364.92	28,094.58	75.00
Education Fund		TITLE II TRS	2,156.48	128.83	0.00	0.00	1,162.41	994.07	46.10
Education Fund	10-2210-	DIRECTOR C/I TRS	16,884.28	1,407.06	0.00	0.00	4,220.81	12,663.47	75.00
Education Fund	12210211	DIR OF C/I TRS	0.00	0.00	0.00	0.00	0.00	0.00	0.00
Education Fund		TITLE II TRS	45.05	0.00	0.00	0.00	0.00	45.05	100.00
Education Fund	10-2210-	DIRECTOR C/I SALARY	0.00	0.00	0.00	0.00	0.00	0.00	0.00
Education Fund	12210222	DIRECTOR C/I INS	36,158.76	2,962.18	0.00	0.00	10,901.24	25,257.52	69.85
Education Fund		10 E 2210 2220 00 300	0.00	0.00	0.00	0.00	0.00	0.00	194 0.00
Education Fund	12210223	DIR C/I SEC INSURANCE	35,770.68	2,944.46	0.00	0.00	10,871.50	24,899.18	69.61
Education Fund		DIRECTOR C/I DENTAL INS	1,518.80	128.46	0.00	0.00	410.18	1,108.62	72.99
Education Fund		10 E 2210 2230 00 300	0.00	0.00	0.00	0.00	0.00	0.00	0.00
Education Fund		DIR C/I SEC DENTAL INS	476.03	40.26	0.00	0.00	131.27	344.76	72.42
Education Fund	12210305	TITLE II PURCHASE	17,400.00	0.00	0.00	0.00	6,296.17	11,103.83	63.82
Education Fund	12200303	IDEA PART B SP ED PROF	0.00	0.00	0.00	0.00	0.00	0.00	0.00
Education Fund	12200304	IDEA PART B SP ED PROF	0.00	0.00	0.00	0.00	0.00	0.00	0.00
Education Fund	12210300	IDEA PART B SP ED PROF	13,387.00	1,039.48	398.00	0.00	6,083.36	6,905.64	51.58
Education Fund	12210302	IDEA PART B SP ED PROF	0.00	0.00	0.00	0.00	0.00	0.00	0.00
Education Fund	12210303	IDEA PART B SP ED PROF	0.00	0.00	0.00	0.00	0.00	0.00	0.00
Education Fund	12210304	IDEA PART B SP ED PROF	0.00	0.00	0.00	0.00	0.00	0.00	0.00
Education Fund	12210306	TESTING SERVICE	111,000.00	-2,000.00	113,277.00	0.00	-4,649.00	2,372.00	2.14
Education Fund	12210390	DIRECTOR C/I PURCHASE	0.00	0.00	0.00	0.00	0.00	0.00	0.00

## Expenditure Report

Fiscal Year: 2023-2024  
Month: March

COUNTY OF GRUNDY SCHOOL DIST 111

Fund Description	Account	Account Description	Revised Budget	MTD Activity	Encumbrance	Pending Activity	Available Funds	Year to Date Activity	Percent of Budget Used
Education Fund	1221031005	PROF DEVEL ENGLISH	3,800.00	0.00	595.00	0.00	1,692.00	1,513.00	39.82
Education Fund	1221031106	PROF DEVEL WORLD	3,800.00	0.00	400.00	0.00	524.56	2,875.44	75.67
Education Fund	1221031210	PROF DEVEL CTE	3,800.00	0.00	0.00	0.00	3,569.44	230.56	6.07
Education Fund	1221030811	PROF DELEV MATH	3,800.00	0.00	190.16	115.00	1,271.89	2,222.95	58.50
Education Fund	1221030913	PROF DEVEL SCIENCE	3,800.00	0.00	0.00	0.00	3,800.00	0.00	0.00
Education Fund	1221031315	PROF DEVEL SOCIAL	3,800.00	200.00	0.00	0.00	2,651.00	1,149.00	30.24
Education Fund	1221030750	PROF DEVEL	3,800.00	0.00	0.00	0.00	2,537.30	1,262.70	33.23
Education Fund	12210301	PROF. DEVELOPMENT	20,000.00	-239.00	344.00	0.00	16,923.10	2,732.90	13.66
Education Fund	12210401	SPECIAL ED GRANT	0.00	0.00	0.00	0.00	0.00	0.00	0.00
Education Fund	12210400	DIRECTOR C/I SUPPLIES	750.00	142.99	0.00	0.00	388.34	361.66	48.22
Education Fund	12210402	TITLE II SUPPLIES	4,500.00	0.00	772.73	0.00	-4,104.92	7,832.19	19574.05
Education Fund	12210640	DIRECTOR C/I	750.00	0.00	0.00	0.00	321.00	429.00	57.20
Education Fund	12210642	DIRECTOR C/I	0.00	0.00	0.00	0.00	0.00	0.00	0.00
Education Fund	12212211	CURR DEVLOP/LEARN	0.00	0.00	0.00	0.00	0.00	0.00	0.00
Education Fund	12213211	TYPE 75 TRS	0.00	0.00	0.00	0.00	0.00	0.00	0.00
Education Fund	12220400	LIBRARY CHAPTER II	0.00	0.00	0.00	0.00	0.00	0.00	0.00
Education Fund	12222110	CYBRARY AIDE SALARY	59,149.20	4,929.10	0.00	0.00	15,034.37	44,114.83	74.58
Education Fund	12222111	LIBRARY SALARY	59,608.08	4,681.34	0.00	0.00	15,891.26	43,716.82	73.34
Education Fund	12222112	CYBRARY AIDE SALARY S.	30,307.20	2,525.60	0.00	0.00	7,585.36	22,721.84	74.97
Education Fund	12222211	LIBRARY TRS	0.00	0.00	0.00	0.00	0.00	0.00	0.00
Education Fund		LIBRARY TRS	7,154.64	561.88	0.00	0.00	1,907.45	5,247.19	73.34
Education Fund	122222112	LIB ASST TRS S.C.	0.00	0.00	0.00	0.00	0.00	0.00	0.00
Education Fund	12222222	LIBRARY AIDE GROUP INS	42,592.56	3,858.20	0.00	0.00	9,721.68	32,870.88	77.18
Education Fund		LIBRARY GROUP INS	11,431.20	940.14	0.00	0.00	3,414.78	8,016.42	70.13

## Expenditure Report

Fiscal Year: 2023-2024  
Month: March

COUNTY OF GRUNDY SCHOOL DIST 111

Fund Description	Account	Account Description	Revised Budget	MTD Activity	Encumbrance	Pending Activity	Available Funds	Year to Date Activity	Percent of Budget Used
Education Fund	10-2222-	LIB ASST SALARY S.C.	35,595.65	2,931.26	0.00	0.00	10,622.03	24,973.62	70.16
Education Fund		LIBRARY DENT INS	476.03	40.26	0.00	0.00	128.57	347.46	72.99
Education Fund	12222300	LIBRARY CONTRACT SERV	0.00	0.00	0.00	0.00	0.00	0.00	0.00
Education Fund	122223002	LIBRARY CONT SERV S.C.	0.00	0.00	0.00	0.00	0.00	0.00	0.00
Education Fund	12222410	LIBRARY SUPPLIES	9,000.00	0.00	750.43	0.00	4,587.31	3,662.26	40.69
Education Fund	12222411	LIBRARY COMP TECH	0.00	0.00	0.00	0.00	0.00	0.00	0.00
Education Fund	122224102	LIBRARY SUPPLIES S.C.	0.00	0.00	0.00	0.00	0.00	0.00	0.00
Education Fund	122224112	LIBRARY COMP TECH	0.00	0.00	0.00	0.00	0.00	0.00	0.00
Education Fund	12222430	LIBRARY BOOKS	24,000.00	1,829.81	2,525.69	0.00	6,259.01	15,215.30	63.40
Education Fund	12222431	PER CAPITA GRANT	2,500.00	0.00	1,697.56	0.00	802.44	0.00	0.00
Education Fund	122224302	LIBRARY BOOKS S.C.	0.00	0.00	0.00	0.00	0.00	0.00	196 0.00
Education Fund	12222440	LIBRARY PERIODICALS	68,500.00	0.00	3,983.42	0.00	0.00	64,516.58	94.18
Education Fund	122224402	LIBRARY PERIODICALS S.	0.00	0.00	0.00	0.00	0.00	0.00	0.00
Education Fund	12222540	LIBRARY EQUIPMENT	0.00	0.00	0.00	0.00	0.00	0.00	0.00
Education Fund	122225402	LIBRARY EQUIPMENT S.C.	0.00	0.00	0.00	0.00	0.00	0.00	0.00
Education Fund	12222640	LIBRARY DUES/FEES/LIT	0.00	0.00	0.00	0.00	0.00	0.00	0.00
Education Fund	122226402	LIBRARY DUES/FEES/LIT S	0.00	0.00	0.00	0.00	0.00	0.00	0.00
Education Fund	12225110	TECH COORD SALARY	102,430.72	8,535.90	0.00	0.00	25,607.62	76,823.10	75.00
Education Fund	12225111	TECH ASST SALARY	87,812.10	7,507.67	0.00	0.00	21,205.29	66,606.81	75.85
Education Fund	12225112	TECH/CYBRARY AIDE	0.00	0.00	0.00	0.00	0.00	0.00	0.00
Education Fund	12225113	TECH ASST SALARY S.C.	71,548.62	5,962.38	0.00	0.00	18,259.20	53,289.42	74.48
Education Fund	12225120	SUMMER TECH HELPERS	16,000.00	0.00	0.00	0.00	4,267.50	11,732.50	73.33
Education Fund	12225211	TECH/CYBRARY AIDE TRS	344.86	0.00	0.00	0.00	0.00	344.86	100.00
Education Fund	10-2225-	TECH ASST SALARY S.C.	0.00	0.00	0.00	0.00	0.00	0.00	0.00

## Expenditure Report

Fiscal Year: 2023-2024  
Month: March

COUNTY OF GRUNDY SCHOOL DIST 111

Fund Description	Account	Account Description	Revised Budget	MTD Activity	Encumbrance	Pending Activity	Available Funds	Year to Date Activity	Percent of Budget Used
Education Fund	12225222	TECHNOLOGY GROUP INS	34,528.51	3,113.54	0.00	0.00	8,007.63	26,520.88	76.81
Education Fund		TECH ASST GROUP INS	34,072.64	3,098.76	0.00	0.00	7,665.20	26,407.44	77.50
Education Fund		TECH COORD GROUP INS	494.32	1,944.98	0.00	0.00	-16,086.50	16,580.82	3,354.27
Education Fund		TECH COORD DENTAL INS	1,518.80	128.46	0.00	0.00	534.32	984.48	64.82
Education Fund		TECH ASST DENTAL INS	474.16	40.26	0.00	0.00	126.70	347.46	73.28
Education Fund		TECH/HR DENTAL INS	714.17	60.40	0.00	0.00	192.89	521.28	72.99
Education Fund	12225300	COMPUTER CONTRACT	4,500.00	0.00	0.00	0.00	-1,477.98	5,977.98	132.84
Education Fund	12225301	INTERNET SERVICE	54,000.00	5,151.76	0.00	0.00	7,714.93	46,285.07	85.71
Education Fund	12225390	CLOSING THE GAP	0.00	0.00	0.00	0.00	0.00	0.00	0.00
Education Fund	12225393	POWER SCHOOL TECH	81,875.00	0.00	0.00	0.00	-406.05	82,281.05	100.50
Education Fund	12225400	COMPUTER RESALE	0.00	0.00	0.00	0.00	0.00	0.00	197 0.00
Education Fund	12225410	COMPUTER SUPPLIES	25,000.00	1,040.57	364.24	0.00	12,428.95	12,206.81	48.83
Education Fund	12225411	COMPUTER COMP TECH	0.00	0.00	0.00	0.00	0.00	0.00	0.00
Education Fund	12225420	COMPUTER TEXTBOOKS	0.00	0.00	0.00	0.00	0.00	0.00	0.00
Education Fund	12225490	COMPUTER SOFTWARE	221,000.00	5,554.50	3,781.25	0.00	2,759.91	214,458.84	97.04
Education Fund	12225540	COMPUTER EQUIPMENT	83,000.00	1,854.75	638.01	0.00	6,726.07	75,635.92	91.13
Education Fund	12225541	TECH COMPUTER LEASE	429,000.00	0.00	302,950.00	0.00	-302,756.15	428,806.15	99.95
Education Fund	12225542	COMPUTER LEASE	0.00	0.00	0.00	0.00	0.00	0.00	0.00
Education Fund	12225543	POWER SCHOOL	0.00	0.00	0.00	0.00	0.00	0.00	0.00
Education Fund	12225640	COMPUTER DUES &	0.00	0.00	0.00	0.00	0.00	0.00	0.00
Education Fund	12225710	COMPUTERS - NON	0.00	0.00	0.00	0.00	0.00	0.00	0.00
Education Fund		DIST 111 GROUP DENTAL	0.00	0.00	0.00	0.00	0.00	0.00	0.00
Education Fund		TITLE I TESTING SALARIES	1,800.00	0.00	0.00	0.00	1,800.00	0.00	0.00
Education Fund		TESTING SALARIES TRS	220.55	0.00	0.00	0.00	220.55	0.00	0.00

## Expenditure Report

Fiscal Year: 2023-2024  
Month: March

COUNTY OF GRUNDY SCHOOL DIST 111

Fund Description	Account	Account Description	Revised Budget	MTD Activity	Encumbrance	Pending Activity	Available Funds	Year to Date Activity	Percent of Budget Used
Education Fund	12230300	TITLE 1 PURCHASE	0.00	0.00	0.00	0.00	0.00	0.00	0.00
Education Fund	12230400	IDEA SUPPLIES SOC	375.00	0.00	0.00	0.00	-334.96	709.96	189.32
Education Fund		TITLE I TESTING SUPPLIES	10,500.00	10,011.32	105.56	0.00	383.12	10,011.32	95.35
Education Fund	12300100	TITLE 1 DIRECTOR	0.00	0.00	0.00	0.00	0.00	0.00	0.00
Education Fund	12300120	TEST PROCTOR	0.00	0.00	0.00	0.00	-273.00	273.00	0.00
Education Fund	10-2300-211	TEST PROCTOR (BT)	0.00	0.00	0.00	0.00	-32.76	32.76	0.00
Education Fund	10-2300-222	TEST PROCTOR (BME	0.00	0.00	0.00	0.00	0.00	0.00	0.00
Education Fund	12300500	IDEA GRANT DIR STUDENT	0.00	0.00	0.00	0.00	0.00	0.00	0.00
Education Fund	12310200	BOARD OF ED-OTHER	0.00	0.00	0.00	0.00	0.00	0.00	0.00
Education Fund	12310211	BOARD OF ED TRS	0.00	0.00	0.00	0.00	0.00	0.00	0.00
Education Fund	12310222	COBRA INSURANCE	0.00	0.00	0.00	0.00	0.00	0.00	198 0.00
Education Fund	12310301	FORMER EMPLOYEE	0.00	0.00	0.00	0.00	0.00	0.00	0.00
Education Fund	12310300	BOARD OF ED PUR SERV	35,000.00	540.00	0.00	0.00	21,636.30	13,363.70	38.18
Education Fund	12310302	COBRA INSURANCE	0.00	0.00	0.00	0.00	0.00	0.00	0.00
Education Fund	12310310	ARCHITECT FEES	0.00	0.00	0.00	0.00	0.00	0.00	0.00
Education Fund	12310311	HEARING OFFICER PUR	4,000.00	0.00	0.00	0.00	4,000.00	0.00	0.00
Education Fund	12310316	TREES ADMIN	5,000.00	0.00	0.00	0.00	-128.00	5,128.00	102.56
Education Fund	12310314	REVTRAK CREDIT CARD	40,000.00	6,856.41	0.00	0.00	-32,457.89	72,457.89	181.14
Education Fund	12310317	AUDIT SERVICES	25,000.00	0.00	0.00	0.00	6,150.00	18,850.00	75.40
Education Fund	12310315	ASSESSMENT APPEALS	0.00	0.00	0.00	0.00	0.00	0.00	0.00
Education Fund	12310318	ATTORNEY FEES	0.00	0.00	0.00	0.00	0.00	0.00	0.00
Education Fund	12310319	BACKGROUND INVEST	0.00	0.00	0.00	0.00	0.00	0.00	0.00
Education Fund	12310380	GEN LIABILITY INSURANCE	0.00	0.00	0.00	0.00	0.00	0.00	0.00
Education Fund	12310381	INSURANCE CONSULTING	0.00	0.00	0.00	0.00	0.00	0.00	0.00

## Expenditure Report

Fiscal Year: 2023-2024  
Month: March

COUNTY OF GRUNDY SCHOOL DIST 111

Fund Description	Account	Account Description	Revised Budget	MTD Activity	Encumbrance	Pending Activity	Available Funds	Year to Date Activity	Percent of Budget Used
Education Fund	12310382	TREASURERS BOND	14,000.00	0.00	0.00	0.00	1,104.00	12,896.00	92.11
Education Fund	12310390	BOARD OF ED/OTH PUR	0.00	0.00	0.00	0.00	0.00	0.00	0.00
Education Fund	12310411	DONATIONS	0.00	0.00	0.00	0.00	0.00	0.00	0.00
Education Fund	12310410	BOARD OF ED SUPPLIES	18,000.00	1,957.91	0.00	0.00	6,075.15	11,924.85	66.25
Education Fund	12310412	EDUCATION FOUNDATION	10,000.00	302.15	45.83	546.50	-3,654.68	13,062.35	130.62
Education Fund	12310540	BOARD OF ED EQUIPMENT	0.00	0.00	0.00	0.00	0.00	0.00	0.00
Education Fund	12310640	BOARD OF ED CLINICS	9,000.00	0.00	0.00	0.00	1,323.58	7,676.42	85.29
Education Fund	12310641	BOARD OF ED DUES	20,000.00	0.00	0.00	0.00	16,251.01	3,748.99	18.74
Education Fund	12312110	BOARD SECY SALARY	0.00	0.00	0.00	0.00	0.00	0.00	0.00
Education Fund	12313110	PERFORMANCE PAY	0.00	0.00	0.00	0.00	0.00	0.00	0.00
Education Fund	12313211	PERFORMANCE TRS	0.00	0.00	0.00	0.00	0.00	0.00	199 0.00
Education Fund	12313216	PERFORMANCE ANNUITY	0.00	0.00	0.00	0.00	0.00	0.00	0.00
Education Fund	12321110	SUPT SECY SALARY	58,246.50	4,853.88	0.00	0.00	13,706.64	44,539.86	76.47
Education Fund	12321111	SUPT SALARY	199,280.00	16,606.66	0.00	0.00	49,820.06	149,459.94	75.00
Education Fund	12321112	PRIOR SUPERINTENDENT	0.00	0.00	0.00	0.00	0.00	0.00	0.00
Education Fund	12321113	INTERIM SUPT SALARY	0.00	0.00	0.00	0.00	0.00	0.00	0.00
Education Fund	12321211		0.00	0.00	0.00	0.00	0.00	0.00	0.00
Education Fund	12321212	SUPT TRS	24,417.27	2,034.80	0.00	0.00	6,010.41	18,406.86	75.38
Education Fund	12321216	SUPT ANNUITY	0.00	0.00	0.00	0.00	0.00	0.00	0.00
Education Fund	10-2321-	SUPT SALARY (GTL)	0.00	0.00	0.00	0.00	0.00	0.00	0.00
Education Fund	12321222	SUPT GROUP INS	32,517.67	2,944.46	0.00	0.00	7,424.89	25,092.78	77.17
Education Fund	12321223	SUPT SECY GROUP INS	32,871.43	2,971.58	0.00	0.00	7,534.09	25,337.34	77.08
Education Fund		SUPT SEC DENTAL INS	476.03	40.26	0.00	0.00	128.57	347.46	72.99
Education Fund		SUPT DENTAL INS	1,518.80	128.46	0.00	0.00	410.18	1,108.62	72.99

## Expenditure Report

Fiscal Year: 2023-2024  
Month: March

COUNTY OF GRUNDY SCHOOL DIST 111

Fund Description	Account	Account Description	Revised Budget	MTD Activity	Encumbrance	Pending Activity	Available Funds	Year to Date Activity	Percent of Budget Used
Education Fund	12321390	SUPT CONTRACT SERV	0.00	0.00	0.00	0.00	0.00	0.00	0.00
Education Fund	12321310	SUPT PHYSICAL	0.00	0.00	0.00	0.00	0.00	0.00	0.00
Education Fund	12321323	SUPT REPAIR/MAINT	0.00	0.00	0.00	0.00	0.00	0.00	0.00
Education Fund	12321332	SUPT SECY MILEAGE	0.00	0.00	0.00	0.00	0.00	0.00	0.00
Education Fund	12321333	SUPT MILEAGE	0.00	0.00	0.00	0.00	0.00	0.00	0.00
Education Fund	12321410	SUPT SUPPLIES	1,500.00	0.00	0.00	0.00	-826.24	2,326.24	155.08
Education Fund	12321540	SUPT EQUIPMENT	0.00	0.00	0.00	0.00	0.00	0.00	0.00
Education Fund	12321640	SUPT DUES/LIT	3,500.00	50.00	0.00	0.00	2,003.85	1,496.15	42.75
Education Fund	12321641	SUPT SECY CLINIC	0.00	0.00	0.00	0.00	0.00	0.00	0.00
Education Fund	12321642	SUPT CLINIC	3,500.00	0.00	0.00	0.00	2,610.08	889.92	25.43
Education Fund	12300400	IDEA GRANT GENERAL	0.00	0.00	0.00	0.00	0.00	0.00	200 0.00
Education Fund	12410110	PRIN SECYS SALARY	37,459.50	3,179.25	0.00	0.00	9,528.21	27,931.29	74.56
Education Fund	12410111	PRINCIPAL SALARY	153,700.00	12,808.34	0.00	0.00	38,424.94	115,275.06	75.00
Education Fund	12410112	ASST PRIN SECY SALARY	58,999.84	4,882.72	0.00	0.00	14,949.70	44,050.14	74.66
Education Fund	12410113	ASST PRINCIPAL SALARY	136,199.65	11,349.98	0.00	0.00	34,049.83	102,149.82	75.00
Education Fund	12410115	DEANS SALARY	421,056.24	29,161.46	0.00	0.00	158,228.97	262,827.27	62.42
Education Fund	124101132	ASST PRIN SALARY S.C.	114,861.60	9,571.80	0.00	0.00	28,715.40	86,146.20	75.00
Education Fund	12410114	PRINCIPAL SALARY S.C.	0.00	0.00	0.00	0.00	0.00	0.00	0.00
Education Fund	12410211	PRINCIPAL TRS	0.00	0.00	0.00	0.00	0.00	0.00	0.00
Education Fund	12410212	PRINCIPAL TRS	18,832.47	1,569.38	0.00	0.00	4,708.07	14,124.40	75.00
Education Fund		ASST PRINCIPAL TRS	16,688.20	1,390.68	0.00	0.00	4,172.08	12,516.12	75.00
Education Fund		DEANS TRS	51,590.95	3,500.26	0.00	0.00	20,272.33	31,318.62	60.71
Education Fund	12410214	PRINCIPAL TRS S.C.	14,073.70	1,172.82	0.00	0.00	3,518.34	10,555.36	75.00
Education Fund	10-2410-	PRINCIPAL SALARY (GTL)	0.00	0.00	0.00	0.00	0.00	0.00	0.00

## Expenditure Report

Fiscal Year: 2023-2024  
Month: March

COUNTY OF GRUNDY SCHOOL DIST 111

Fund Description	Account	Account Description	Revised Budget	MTD Activity	Encumbrance	Pending Activity	Available Funds	Year to Date Activity	Percent of Budget Used
Education Fund	10-2410-	ASST PRIN SALARY S.C.	0.00	0.00	0.00	0.00	0.00	0.00	0.00
Education Fund	12410222	PRIN SEC GROUP INS	10,939.90	2,944.46	0.00	0.00	-12,837.65	23,777.55	217.35
Education Fund	12410223	PRINCIPAL GROUP INS	32,757.78	1,991.46	0.00	0.00	9,431.77	23,326.01	71.21
Education Fund	12410224	ASST PRIN SEC GROUP	22,203.06	2,009.66	0.00	0.00	5,074.44	17,128.62	77.15
Education Fund		ASST PRIN GROUP INS	34,443.02	3,116.38	0.00	0.00	7,871.76	26,571.26	77.15
Education Fund		DEANS GROUP INS	84,599.99	7,658.30	0.00	0.00	19,334.50	65,265.49	77.15
Education Fund	10-2410-	ASST PRIN S.C. MEDICAL	374.88	28.98	0.00	0.00	109.14	265.74	70.89
Education Fund		PRIN SEC DENTAL INS	476.03	40.26	0.00	0.00	146.90	329.13	69.14
Education Fund		PRINCIPAL DENTAL INS	1,518.80	82.70	0.00	0.00	501.70	1,017.10	66.97
Education Fund		ASST PRIN SEC DENTAL	476.03	40.26	0.00	0.00	128.57	347.46	72.99
Education Fund		ASST PRIN DENTAL INS	997.42	40.26	0.00	0.00	649.96	347.46	20134.84
Education Fund		DEANS DENTAL INS	1,822.43	140.88	0.00	0.00	606.53	1,215.90	66.72
Education Fund		ASST PRIN S.C. DENTAL	0.00	0.00	0.00	0.00	0.00	0.00	0.00
Education Fund	12410390	ASST PRIN PURCHASE	2,500.00	0.00	0.00	100.00	1,244.60	1,155.40	46.22
Education Fund	12410391	PRIN PURCHASE SERV	0.00	0.00	0.00	0.00	-662.20	662.20	0.00
Education Fund	124103902	ASST PRIN CONT SERV S	0.00	0.00	0.00	0.00	0.00	0.00	0.00
Education Fund	124103912	PRIN CONT SERV S	0.00	0.00	0.00	0.00	0.00	0.00	0.00
Education Fund	12410340	POSTAGE	25,000.00	2,000.00	0.00	3,535.34	10,393.98	11,070.68	44.28
Education Fund	12410410	ASST PRIN SUPPLIES	17,000.00	0.00	39.99	0.00	7,546.60	9,413.41	55.37
Education Fund	12410411	PRINCIPAL SUPPLIES	17,000.00	210.00	0.00	0.00	858.90	16,141.10	94.95
Education Fund	12410412	GRADUATION SUPPLIES	18,000.00	148.95	0.00	0.00	17,084.10	915.90	5.09
Education Fund	12410413	PRINCIPAL COMP TECH	0.00	0.00	0.00	0.00	0.00	0.00	0.00
Education Fund	12410414	ASST PRIN COMP TECH	0.00	0.00	0.00	0.00	0.00	0.00	0.00
Education Fund	12410415	IMTT GRANT SUPPLIES	0.00	0.00	0.00	0.00	0.00	0.00	0.00

## Expenditure Report

Fiscal Year: 2023-2024  
Month: March

COUNTY OF GRUNDY SCHOOL DIST 111

Fund Description	Account	Account Description	Revised Budget	MTD Activity	Encumbrance	Pending Activity	Available Funds	Year to Date Activity	Percent of Budget Used
Education Fund	124104102	ASST PRIN SUPPLIES S	8,000.00	0.00	0.00	0.00	578.78	7,421.22	92.77
Education Fund	124104112	PRINCIPAL SUPPLIES S	0.00	0.00	0.00	0.00	-2,492.96	2,492.96	0.00
Education Fund	124104132	PRINCIPAL COMP TECH	0.00	0.00	0.00	0.00	0.00	0.00	0.00
Education Fund	124104142	ASST PRIN COMP TECH	0.00	0.00	0.00	0.00	0.00	0.00	0.00
Education Fund	12410540	PRINCIPAL EQUIPMENT	0.00	0.00	0.00	0.00	0.00	0.00	0.00
Education Fund	12410541	ASST PRIN EQUIPMENT	0.00	0.00	0.00	0.00	0.00	0.00	0.00
Education Fund	124105402	PRINCIPAL EQUIPMENT S	0.00	0.00	0.00	0.00	0.00	0.00	0.00
Education Fund	124105412	ASST PRIN EQUIPMENT S	0.00	0.00	0.00	0.00	0.00	0.00	0.00
Education Fund	12410640	PRINCIPAL DUES/LIT	1,500.00	0.00	0.00	0.00	1,500.00	0.00	0.00
Education Fund	12410641	ASST PRIN DUES/LIT	1,500.00	0.00	0.00	0.00	1,081.00	419.00	27.93
Education Fund	12410642	PRINCIPAL	0.00	0.00	0.00	0.00	0.00	0.00	202 0.00
Education Fund	12410643	ASST PRIN	0.00	0.00	0.00	0.00	0.00	0.00	0.00
Education Fund	12410644	SPC DUES	9,000.00	0.00	0.00	0.00	500.00	8,500.00	94.44
Education Fund	124106402	PRINCIPAL DUES/LIT S	500.00	0.00	0.00	0.00	71.00	429.00	85.80
Education Fund	124106412	ASST PRIN DUES/LIT S	0.00	0.00	0.00	0.00	0.00	0.00	0.00
Education Fund	124106422	PRINCIPAL	0.00	0.00	0.00	0.00	0.00	0.00	0.00
Education Fund	124106432	ASST PRIN	0.00	0.00	0.00	0.00	0.00	0.00	0.00
Education Fund	12490110	DEANS SECY SALARY	69,615.60	5,556.56	0.00	0.00	21,605.52	48,010.08	68.96
Education Fund	12490112	DEANS SALARY	0.00	0.00	0.00	0.00	0.00	0.00	0.00
Education Fund	12490212	DEANS TRS	0.00	0.00	0.00	0.00	0.00	0.00	0.00
Education Fund	12490222	DEANS SEC INS	50,563.39	2,956.98	0.00	0.00	25,451.64	25,111.75	49.66
Education Fund	12490223	DEANS GROUP INS	0.00	0.00	0.00	0.00	0.00	0.00	0.00
Education Fund		DEAN SEC DENTAL INS	552.68	49.68	0.00	0.00	169.96	382.72	69.25
Education Fund	12490390	DEANS PURCHASE	0.00	0.00	0.00	0.00	0.00	0.00	0.00

## Expenditure Report

Fiscal Year: 2023-2024  
Month: March

COUNTY OF GRUNDY SCHOOL DIST 111

Fund Description	Account	Account Description	Revised Budget	MTD Activity	Encumbrance	Pending Activity	Available Funds	Year to Date Activity	Percent of Budget Used
Education Fund	124903902	DEANS CONT SERV S	0.00	0.00	0.00	0.00	0.00	0.00	0.00
Education Fund	12490410	DEANS SUPPLIES	2,000.00	0.00	0.00	0.00	-968.18	2,968.18	148.41
Education Fund	12490411	DEANS COMP TECH	0.00	0.00	0.00	0.00	0.00	0.00	0.00
Education Fund	124904102	DEANS SUPPLIES S	0.00	0.00	0.00	0.00	0.00	0.00	0.00
Education Fund	124904112	DEANS COMP TECH	0.00	0.00	0.00	0.00	0.00	0.00	0.00
Education Fund	12490540	DEANS EQUIPMENT	0.00	0.00	0.00	0.00	0.00	0.00	0.00
Education Fund	124905402	DEANS EQUIPMENT S	0.00	0.00	0.00	0.00	0.00	0.00	0.00
Education Fund	12490640	DEANS MILEAGE	0.00	0.00	0.00	17.55	-17.55	0.00	0.00
Education Fund	12490641	DEANS PROF DUES &	0.00	0.00	0.00	0.00	0.00	0.00	0.00
Education Fund	124906402	DEANS MILEAGE S	0.00	0.00	0.00	22.53	-22.53	0.00	0.00
Education Fund	124906412	DEANS DUES/LIT S	0.00	0.00	0.00	0.00	0.00	0.00	203 0.00
Education Fund	12510110	CSBO SALARY	63,586.09	5,299.90	0.00	0.00	15,887.00	47,699.09	75.01
Education Fund	12510211	CSBO TRS	7,791.04	0.00	0.00	0.00	3,200.47	4,590.57	58.92
Education Fund	10-2510-	CSBO SALARY (BIMRF)	0.00	0.00	0.00	0.00	0.00	0.00	0.00
Education Fund	10-2510-	CSBO SALARY (GTL)	0.00	0.00	0.00	0.00	0.00	0.00	0.00
Education Fund	12510222	CSBO GROUP INS	10,931.71	989.06	0.00	0.00	2,500.21	8,431.50	77.13
Education Fund		CSBO DENTAL INS	506.27	42.82	0.00	0.00	136.73	369.54	72.99
Education Fund	12510332	CSBO MILEAGE	500.00	0.00	0.00	0.00	500.00	0.00	0.00
Education Fund	12510640	CSBO DUES/CLINICS	2,500.00	1,080.00	0.00	0.00	-1,360.00	3,860.00	154.40
Education Fund	12510641	SECY SUPPORT CLINICS	0.00	0.00	0.00	0.00	0.00	0.00	0.00
Education Fund	12525110	BUSINESS OFFICE SALARY	337,497.26	28,124.76	0.00	0.00	84,374.36	253,122.90	75.00
Education Fund		BUSINESS OFFICE TRS	24,088.90	1,953.28	0.00	0.00	6,931.73	17,157.17	71.22
Education Fund	12525222	BUSINESS OFFICE GRP	14,825.98	5,758.18	0.00	0.00	-34,269.89	49,095.87	331.15
Education Fund		BUSINESS OFFICE DENTAL	1,384.51	136.88	0.00	0.00	186.23	1,198.28	86.55

## Expenditure Report

Fiscal Year: 2023-2024  
Month: March

COUNTY OF GRUNDY SCHOOL DIST 111

Fund Description	Account	Account Description	Revised Budget	MTD Activity	Encumbrance	Pending Activity	Available Funds	Year to Date Activity	Percent of Budget Used
Education Fund	12525390	BUSINESS OFFICE PUR	0.00	66.00	0.00	0.00	-681.10	681.10	0.00
Education Fund	12525323	BUSINESS OFFICE REPAIR	0.00	0.00	0.00	0.00	0.00	0.00	0.00
Education Fund	12525332	BOOKKEEPER MILEAGE	0.00	0.00	0.00	0.00	0.00	0.00	0.00
Education Fund	12525391	BUSINESS OFFICE CONT	0.00	0.00	0.00	0.00	0.00	0.00	0.00
Education Fund	12525411	BUSINESS OFFICE COMP	0.00	0.00	0.00	0.00	0.00	0.00	0.00
Education Fund	12525410	BUSINESS OFFICE	4,000.00	106.08	0.00	0.00	708.67	3,291.33	82.28
Education Fund	12525540	BUSINESS OFFICE	0.00	0.00	0.00	0.00	0.00	0.00	0.00
Education Fund	12525640	BOOKKEEPER CLINICS	500.00	0.00	0.00	0.00	500.00	0.00	0.00
Education Fund	12560300	CAFETERIA CONTRACT	1,500,000.00	0.00	0.00	0.00	692,990.59	807,009.41	53.80
Education Fund	12560302	CAFE TECH CONT SERV	0.00	0.00	0.00	0.00	0.00	0.00	0.00
Education Fund	125603002	CAFE PUR SER SOUTH	0.00	0.00	0.00	0.00	0.00	0.00	204 0.00
Education Fund	12560301	SPECIAL FUNCTION	35,000.00	160,502.36	0.00	0.00	-154,142.99	189,142.99	540.41
Education Fund	125603012	SPECIAL FUNCTION	0.00	0.00	0.00	0.00	0.00	0.00	0.00
Education Fund	12560323	CAFETERIA REPAIR/MAINT	15,000.00	12,417.03	235.38	0.00	-3,930.66	18,695.28	124.64
Education Fund	125603232	CAFE REPAIR/MAINT	0.00	0.00	0.00	0.00	0.00	0.00	0.00
Education Fund	12560410	CAFETERIA SUPPLIES	14,000.00	0.00	1,060.00	0.00	9,685.47	3,254.53	23.25
Education Fund	12560411	CAFE COMP TECH	0.00	0.00	0.00	0.00	0.00	0.00	0.00
Education Fund	125604102	CAFE SUPPLIES SOUTH	0.00	0.00	0.00	0.00	0.00	0.00	0.00
Education Fund	125604112	CAFE COMP TECH	0.00	0.00	0.00	0.00	0.00	0.00	0.00
Education Fund	12560540	CAFETERIA EQUIPMENT	15,000.00	0.00	0.00	0.00	14,539.95	460.05	3.07
Education Fund	125605402	CAFE EQUIPMENT SOUTH	0.00	0.00	0.00	0.00	0.00	0.00	0.00
Education Fund	125606902	CAFE SOUTH REFUND	0.00	0.00	0.00	0.00	0.00	0.00	0.00
Education Fund	12632110	PRINT ROOM SALARY	32,742.96	2,483.82	0.00	0.00	9,868.55	22,874.41	69.86
Education Fund	12632211	INTERNAL INFO TRS	0.00	0.00	0.00	0.00	0.00	0.00	0.00

## Expenditure Report

Fiscal Year: 2023-2024  
Month: March

COUNTY OF GRUNDY SCHOOL DIST 111

Fund Description	Account	Account Description	Revised Budget	MTD Activity	Encumbrance	Pending Activity	Available Funds	Year to Date Activity	Percent of Budget Used
Education Fund	12632222	PRINT ROOM GROUP INS	17,492.73	1,472.24	0.00	0.00	4,946.25	12,546.48	71.72
Education Fund		DEAN/PRINT ROOM	257.99	20.14	0.00	0.00	84.17	173.82	67.37
Education Fund	12632390	PRINTER PURCHASE	250,000.00	8,668.88	1,856.00	0.00	129,637.25	118,506.75	47.40
Education Fund	12632323	INTERNAL INFO	0.00	0.00	0.00	0.00	0.00	0.00	0.00
Education Fund	12632411	INTERNAL INFO COMP	0.00	0.00	0.00	0.00	0.00	0.00	0.00
Education Fund	12632410	INTERNAL INFO SUPPLIES	0.00	0.00	0.00	0.00	-976.20	976.20	0.00
Education Fund	12632540	INTERNAL INFO EQUIP	0.00	0.00	0.00	0.00	0.00	0.00	0.00
Education Fund	12633110	COMM RELATIONS	90,000.00	7,500.00	0.00	0.00	22,500.00	67,500.00	75.00
Education Fund	12633222	COMM RELATIONS GROUP	90.72	7.56	0.00	0.00	19.77	70.95	78.21
Education Fund		COMM RELATIONS	0.00	0.00	0.00	0.00	0.00	0.00	0.00
Education Fund	12633390	COMM RELATIONS PUR	18,000.00	0.00	0.00	100.00	1,965.00	15,935.00	20588.53
Education Fund	12633323	COMM RELATIONS	0.00	0.00	0.00	0.00	0.00	0.00	0.00
Education Fund	12633332	COMM RELATIONS	0.00	0.00	0.00	0.00	0.00	0.00	0.00
Education Fund		DISTRICT SCOREBOARD	2,000.00	0.00	0.00	388.00	952.00	660.00	33.00
Education Fund	12633410	COMM RELATIONS	1,200.00	0.00	14.99	0.00	1,105.02	79.99	6.67
Education Fund	12633540	COMM RELATIONS	0.00	0.00	0.00	0.00	0.00	0.00	0.00
Education Fund	12633640	COMM RELATIONS DUES	500.00	0.00	0.00	0.00	-115.00	615.00	123.00
Education Fund		TITLE II RECRUITMENT	1,546.00	0.00	0.00	0.00	1,546.00	0.00	0.00
Education Fund	12900400	TITLE 1 HOMELESS	0.00	0.00	0.00	0.00	0.00	0.00	0.00
Education Fund	13000300	TITLE 1 PARENT	0.00	0.00	0.00	0.00	0.00	0.00	0.00
Education Fund	13000400	TITLE 1 PARENT	0.00	0.00	0.00	0.00	0.00	0.00	0.00
Education Fund	13200130	WELLNESS	0.00	0.00	0.00	0.00	0.00	0.00	0.00
Education Fund	13200131	WELLNESS CNTR/PUBLIC	0.00	0.00	0.00	0.00	0.00	0.00	0.00
Education Fund	13200211	WELLNESS CENTER TRS	0.00	0.00	0.00	0.00	0.00	0.00	0.00

## Expenditure Report

Fiscal Year: 2023-2024  
Month: March

COUNTY OF GRUNDY SCHOOL DIST 111

Fund Description	Account	Account Description	Revised Budget	MTD Activity	Encumbrance	Pending Activity	Available Funds	Year to Date Activity	Percent of Budget Used
Education Fund	10-3200-	WELLNESS	0.00	0.00	0.00	0.00	0.00	0.00	0.00
Education Fund	13200500	WELLNESS CENTER	10,000.00	0.00	0.00	0.00	761.29	9,238.71	92.39
Education Fund		GCSEC Tuition IDEA Flow	246,887.00	23,320.00	0.00	0.00	37,006.40	209,880.60	85.01
Education Fund	14100110	TITLE I SALARY	0.00	0.00	0.00	0.00	0.00	0.00	0.00
Education Fund	14100300	TITLE I PUR SERV	0.00	0.00	0.00	0.00	0.00	0.00	0.00
Education Fund	14100332	TITLE II	2,600.00	0.00	0.00	0.00	-1,821.00	4,421.00	170.04
Education Fund	14100390	TITLE II-PART D	0.00	0.00	0.00	0.00	0.00	0.00	0.00
Education Fund	14100412	TITLE IV	0.00	0.00	0.00	0.00	0.00	0.00	0.00
Education Fund	14100411	TITLE V SUPPLIES	0.00	0.00	0.00	0.00	0.00	0.00	0.00
Education Fund	14100540	TITLE V EQUIPMENT	0.00	0.00	0.00	0.00	0.00	0.00	0.00
Education Fund	14120300	COOP HOUSING ASSESS	0.00	0.00	0.00	0.00	0.00	0.00	206 0.00
Education Fund	14120301	COOP ADMIN ASSESS	0.00	0.00	0.00	0.00	0.00	0.00	0.00
Education Fund	14120670	COOP HOMEBOUND/HOSP	0.00	0.00	0.00	0.00	0.00	0.00	0.00
Education Fund	14140600	GAVC ED EXPENSE	1,053,250.00	114,544.22	0.00	0.00	443,620.25	609,629.75	57.88
Education Fund	14180	DISBURSEMENTS/EXPEND	0.00	0.00	0.00	0.00	0.00	0.00	0.00
Education Fund	14190600	CHANNAHON TAX	0.00	0.00	0.00	0.00	-157,504.80	157,504.80	0.00
Education Fund	14210670	PAYMENTS FOR REGULAR	0.00	0.00	0.00	0.00	0.00	0.00	0.00
Education Fund	14220670	PAYMENTS SPECIAL ED	2,750,000.00	182,222.74	0.00	357.50	722,812.82	2,026,829.68	73.70
Education Fund	10-481-212-	IMRF (BIM)	0.00	0.00	0.00	0.00	0.00	0.00	0.00
Education Fund	10-481-212-	IMRF (BIM)	0.00	0.00	0.00	0.00	0.00	0.00	0.00
Education Fund	10-481-222-	IMRF (BMF 3000)	0.00	0.00	0.00	0.00	0.00	0.00	0.00
Education Fund	10-481-222-	IMRF (BMF 3000)	0.00	0.00	0.00	0.00	0.00	0.00	0.00
Education Fund		ESSER TRS	0.00	0.00	0.00	0.00	0.00	0.00	0.00
Education Fund	15900390	SERVICE CHARGE	2,712.78	0.00	0.00	2,712.98	0.00	-0.20	-0.01

## Expenditure Report

Fiscal Year: 2023-2024  
Month: March

COUNTY OF GRUNDY SCHOOL DIST 111

Fund Description	Account	Account Description	Revised Budget	MTD Activity	Encumbrance	Pending Activity	Available Funds	Year to Date Activity	Percent of Budget Used
Education Fund		CONTINGENCY - KENDALL	0.00	0.00	0.00	0.00	0.00	0.00	0.00
Education Fund		Transfer from other funds	2,000,000.00	0.00	0.00	0.00	2,000,000.00	0.00	0.00
Education Fund		TRANSFER TO CAPITAL	0.00	0.00	0.00	0.00	0.00	0.00	0.00
Education Fund	18130660	PERM TRANS TO O & M	0.00	0.00	0.00	0.00	0.00	0.00	0.00
Education Fund	18400660	TRANS TO DEBT	0.00	0.00	0.00	0.00	0.00	0.00	0.00
Education Fund	18500660	TRANS TO DEBT	0.00	0.00	0.00	0.00	0.00	0.00	0.00
<b>10 - -----</b>			<b>45,749,658.99</b>	<b>3,487,033.89</b>	<b>597,351.60</b>	<b>71,487.58</b>	<b>13,586,305.56</b>	<b>31,494,514.25</b>	
Activity Fund	111999	STUDENT ACTIVITY	0.00	0.00	0.00	0.00	0.00	0.00	0.00
Activity Fund		SPORTS - ATHLETIC HALL	0.00	0.00	0.00	0.00	0.00	0.00	0.00
Activity Fund		SPORTS - ATHLETIC POP	3,300.00	90.05	0.00	0.00	-138.07	3,438.07	104.18
Activity Fund		SPORTS - ATHLETIC	700.00	0.00	0.00	0.00	296.19	403.81	20757.69
Activity Fund		SPORTS - BASEBALL	5,300.00	71.92	0.00	422.00	1,290.28	3,587.72	67.69
Activity Fund		SPORTS - BOYS	15,000.00	1,845.98	270.84	0.00	8,620.14	6,109.02	40.73
Activity Fund		SPORTS - BOYS BOWLING	2,900.00	640.00	0.00	0.00	-22.73	2,922.73	100.78
Activity Fund		SPORTS - BOYS GOLF	3,000.00	0.00	0.00	0.00	2,277.50	722.50	24.08
Activity Fund		SPORTS - BOYS SOCCER	13,000.00	0.00	9,434.00	0.00	-5,627.16	9,193.16	70.72
Activity Fund		SPORTS - BOYS TENNIS	3,300.00	0.00	0.00	0.00	1,617.70	1,682.30	50.98
Activity Fund		SPORTS - BOYS TRACK	9,900.00	4,418.75	728.81	0.00	4,752.44	4,418.75	44.63
Activity Fund		SPORTS - BOYS	2,600.00	0.00	1,099.44	0.00	1,134.58	365.98	14.08
Activity Fund		SPORTS - CHEERLEADERS	51,100.00	8,494.08	0.00	0.00	9,198.36	41,901.64	82.00
Activity Fund		SPORTS - CROSS COUNTY	10,700.00	0.00	0.00	0.00	3,367.52	7,332.48	68.53
Activity Fund		SPORTS - FOOTBALL	90,000.00	1,259.03	48,519.05	417.50	-21,062.56	62,126.01	69.03
Activity Fund		SPORTS - FOOTBALL	0.00	0.00	1,824.72	0.00	-1,824.72	0.00	0.00
Activity Fund		SPORTS - GIRLS	10,100.00	2,918.06	553.00	0.00	-1,006.90	10,553.90	104.49

## Expenditure Report

Fiscal Year: 2023-2024  
Month: March

COUNTY OF GRUNDY SCHOOL DIST 111

Fund Description	Account	Account Description	Revised Budget	MTD Activity	Encumbrance	Pending Activity	Available Funds	Year to Date Activity	Percent of Budget Used
Activity Fund		SPORTS - GIRLS BOWLING	1,900.00	0.00	0.00	0.00	1,792.00	108.00	5.68
Activity Fund		SPORTS - GIRLS GOLF	600.00	0.00	0.00	0.00	192.04	407.96	67.99
Activity Fund		SPORTS - GIRLS SOCCER	8,800.00	894.98	8,129.53	0.00	-4,052.51	4,722.98	53.67
Activity Fund		SPORTS - GIRLS TENNIS	3,400.00	0.00	0.00	0.00	-253.15	3,653.15	107.45
Activity Fund		SPORTS - GIRLS TRACK	8,000.00	0.00	0.00	1,249.75	6,600.75	149.50	1.87
Activity Fund		SPORTS - GIRLS	5,000.00	0.00	480.00	0.00	-12,744.55	17,264.55	345.29
Activity Fund		SPORTS - LACROSSE	1,800.00	0.00	0.00	0.00	1,229.02	570.98	31.72
Activity Fund		SPORTS - OUTDOOR ED	2,200.00	0.00	0.00	0.00	-780.00	2,980.00	135.45
Activity Fund		SPORTS - POMS	60,000.00	0.00	0.00	0.00	23,239.49	36,760.51	61.27
Activity Fund		SPORTS - SOFTBALL	5,000.00	0.00	-1,448.75	0.00	-12,382.95	18,831.70	376.63
Activity Fund		SPORTS - SWIMMING B&G	300.00	0.00	0.00	0.00	300.00	0.00	208 0.00
Activity Fund		SPORTS - BOYS	7,500.00	73.84	60.00	0.00	-319.61	7,759.61	103.46
Activity Fund		SUMMER CAMPS - BAND	25,900.00	0.00	0.00	0.00	25,900.00	0.00	0.00
Activity Fund		SUMMER CAMPS -	0.00	0.00	0.00	0.00	0.00	0.00	0.00
Activity Fund		SUMMER CAMPS - BOYS	12,400.00	0.00	0.00	0.00	5,221.58	7,178.42	57.89
Activity Fund		SUMMER CAMPS - COED	0.00	0.00	0.00	0.00	0.00	0.00	0.00
Activity Fund		SUMMER CAMPS -	0.00	0.00	0.00	0.00	0.00	0.00	0.00
Activity Fund		SUMMER CAMPS - CROSS	3,500.00	0.00	0.00	0.00	88.17	3,411.83	97.48
Activity Fund		SUMMER CAMPS -	17,500.00	0.00	0.00	0.00	-10,800.25	28,300.25	161.72
Activity Fund		SUMMER CAMPS - GIRLS	6,500.00	0.00	0.00	0.00	1,813.89	4,686.11	72.09
Activity Fund		SUMMER CAMPS - GIRLS	7,500.00	0.00	0.00	0.00	-5,250.02	12,750.02	170.00
Activity Fund		SUMMER CAMPS - POMS	1,000.00	0.00	0.00	0.00	1,000.00	0.00	0.00
Activity Fund		SUMMER CAMPS -	3,900.00	0.00	0.00	0.00	2,141.72	1,758.28	45.08
Activity Fund		SUMMER CAMPS -	2,500.00	0.00	0.00	0.00	981.28	1,518.72	60.75

## Expenditure Report

Fiscal Year: 2023-2024  
Month: March

COUNTY OF GRUNDY SCHOOL DIST 111

Fund Description	Account	Account Description	Revised Budget	MTD Activity	Encumbrance	Pending Activity	Available Funds	Year to Date Activity	Percent of Budget Used
Activity Fund		SUMMER CAMPS - TENNIS	2,600.00	0.00	0.00	0.00	-2,536.84	5,136.84	197.57
Activity Fund		SUMMER CAMPS -	0.00	0.00	0.00	0.00	0.00	0.00	0.00
Activity Fund		FOOTBALL TEAM CAMP	20,200.00	0.00	0.00	0.00	19,960.00	240.00	1.19
Activity Fund		SPORTS - GIRLS	1,000.00	664.00	1,332.00	0.00	-4,413.99	4,081.99	408.20
Activity Fund		SUMMER CAMPS -	900.00	0.00	0.00	0.00	900.00	0.00	0.00
Activity Fund		SUMMER CAMPS - BOYS	0.00	0.00	0.00	0.00	0.00	0.00	0.00
Activity Fund		ATHLETIC BOOSTERS	8,300.00	0.00	0.00	0.00	8,300.00	0.00	0.00
Activity Fund		ACTIVITIES - POP	12,900.00	51.98	0.00	0.00	9,860.22	3,039.78	23.56
Activity Fund		ACTIVITIES - ART CLUB	0.00	0.00	0.00	0.00	0.00	0.00	0.00
Activity Fund		ACTIVITIES - ATHLETIC	0.00	0.00	0.00	0.00	0.00	0.00	0.00
Activity Fund		ACTIVITIES - BAND	20,000.00	0.00	0.00	0.00	20,000.00	0.00	209 0.00
Activity Fund		ACTIVITIES - CHESS	200.00	0.00	0.00	0.00	75.00	125.00	62.50
Activity Fund		ACTIVITIES -	0.00	0.00	0.00	0.00	0.00	0.00	0.00
Activity Fund		ACTIVITIES - CHORUS	900.00	0.00	0.00	0.00	900.00	0.00	0.00
Activity Fund		ACTIVITIES - CLASS OF	100.00	0.00	0.00	0.00	-4,175.53	4,275.53	4,275.53
Activity Fund		ACTIVITIES - CLASS OF	0.00	0.00	0.00	0.00	0.00	0.00	0.00
Activity Fund		ACTIVITIES - CLASS OF	0.00	0.00	0.00	0.00	0.00	0.00	0.00
Activity Fund		ACTIVITIES - CLASS OF	0.00	0.00	0.00	0.00	0.00	0.00	0.00
Activity Fund		ACTIVITIES - CLASS OF	2,800.00	0.00	0.00	0.00	2,800.00	0.00	0.00
Activity Fund		ACTIVITIES - CLASS OF	4,600.00	0.00	0.00	0.00	4,449.10	150.90	3.28
Activity Fund		ACTIVITIES - COMMUNITY	0.00	0.00	0.00	0.00	0.00	0.00	0.00
Activity Fund		ACTIVITIES - CULINARY	0.00	0.00	0.00	0.00	0.00	0.00	0.00
Activity Fund		ACTIVITIES - MOCK TRIAL	0.00	0.00	0.00	0.00	0.00	0.00	0.00
Activity Fund		ACTIVITIES - DREAM	0.00	0.00	0.00	0.00	0.00	0.00	0.00

## Expenditure Report

Fiscal Year: 2023-2024  
Month: March

COUNTY OF GRUNDY SCHOOL DIST 111

Fund Description	Account	Account Description	Revised Budget	MTD Activity	Encumbrance	Pending Activity	Available Funds	Year to Date Activity	Percent of Budget Used
Activity Fund		ACTIVITIES - FASHION	0.00	0.00	0.00	0.00	0.00	0.00	0.00
Activity Fund		ACTIVITIES - FCCLA	0.00	0.00	0.00	0.00	0.00	0.00	0.00
Activity Fund		ACTIVITIES - FFA	4,100.00	0.00	0.00	0.00	4,100.00	0.00	0.00
Activity Fund		ACTIVITIES - FRENCH NHS	0.00	0.00	0.00	0.00	0.00	0.00	0.00
Activity Fund		ACTIVITIES - FUTURE	0.00	0.00	0.00	0.00	0.00	0.00	0.00
Activity Fund		ACTIVITIES - I.O.T.A.	900.00	0.00	0.00	0.00	900.00	0.00	0.00
Activity Fund		ACTIVITIES - INDIAN	700.00	0.00	0.00	0.00	700.00	0.00	0.00
Activity Fund		ACTIVITIES - INDIAN	0.00	0.00	0.00	0.00	0.00	0.00	0.00
Activity Fund		ACTIVITIES - INT'L CLUB	4,200.00	0.00	0.00	0.00	4,200.00	0.00	0.00
Activity Fund		ACTIVITIES - THEATER	7,000.00	83.03	0.00	0.00	-208.41	7,208.41	102.98
Activity Fund		ACTIVITIES - INTERACT	0.00	0.00	0.00	0.00	-93.81	93.81	210 0.00
Activity Fund		ACTIVITIES - INVESTMENT	0.00	0.00	0.00	0.00	0.00	0.00	0.00
Activity Fund		ACTIVITIES - JUDO	0.00	0.00	0.00	0.00	-198.56	198.56	0.00
Activity Fund		ACTIVITIES -	0.00	0.00	0.00	0.00	0.00	0.00	0.00
Activity Fund		ACTIVITIES - MAC	8,000.00	0.00	0.00	0.00	2,885.35	5,114.65	63.93
Activity Fund		ACTIVITIES - MATH TEAM	0.00	0.00	0.00	0.00	0.00	0.00	0.00
Activity Fund		ACTIVITIES - MCHS BOOK	100.00	0.00	0.00	0.00	100.00	0.00	0.00
Activity Fund		ACTIVITIES - MEMORIAL	0.00	0.00	0.00	0.00	0.00	0.00	0.00
Activity Fund		ACTIVITIES - MUSICAL	600.00	0.00	0.00	0.00	600.00	0.00	0.00
Activity Fund		ACTIVITIES - NEEDY	6,600.00	0.00	0.00	0.00	2,310.32	4,289.68	65.00
Activity Fund		ACTIVITIES - NHS	1,700.00	0.00	0.00	0.00	1,458.20	241.80	14.22
Activity Fund		ACTIVITIES - ORCHESTRIS	2,600.00	1,025.94	2,639.92	0.00	-1,159.04	1,119.12	43.04
Activity Fund		ACTIVITIES - PAC	3,000.00	565.25	0.00	0.00	-514.35	3,514.35	117.15
Activity Fund		ACTIVITIES - PERCUSSION	20,100.00	0.00	0.00	0.00	4,157.13	15,942.87	79.32

## Expenditure Report

Fiscal Year: 2023-2024  
Month: March

COUNTY OF GRUNDY SCHOOL DIST 111

Fund Description	Account	Account Description	Revised Budget	MTD Activity	Encumbrance	Pending Activity	Available Funds	Year to Date Activity	Percent of Budget Used
Activity Fund		ACTIVITIES - GAME CLUB	0.00	0.00	0.00	0.00	0.00	0.00	0.00
Activity Fund		ACTIVITIES - NEWSPAPER	0.00	0.00	0.00	0.00	0.00	0.00	0.00
Activity Fund		ACTIVITIES - SADD	100.00	0.00	0.00	0.00	100.00	0.00	0.00
Activity Fund		ACTIVITIES - SCHOLASTIC	100.00	0.00	0.00	0.00	100.00	0.00	0.00
Activity Fund		ACTIVITIES - SPANISH NHS	2,300.00	0.00	0.00	0.00	1,874.50	425.50	18.50
Activity Fund		ACTIVITIES - SPEECH	0.00	0.00	0.00	0.00	0.00	0.00	0.00
Activity Fund		ACTIVITIES - STUDENT	48,100.00	2,546.60	107.77	0.00	1,723.89	46,268.34	96.19
Activity Fund		ACTIVITIES - TSA	3,400.00	0.00	0.00	0.00	2,687.34	712.66	20.96
Activity Fund		ACTIVITIES -	2,400.00	0.00	0.00	0.00	2,093.37	306.63	12.78
Activity Fund		ACTIVITIES -	22,000.00	4,300.00	0.00	34.99	-1,442.13	23,407.14	106.40
Activity Fund		ACTIVITIES - WYSE	0.00	0.00	0.00	0.00	0.00	0.00	211 0.00
Activity Fund		ACTIVITIES - YEARBOOK	11,700.00	144.95	0.00	0.00	8,354.80	3,345.20	28.59
Activity Fund		ACTIVITIES - ALLIES IN	100.00	0.00	0.00	0.00	73.94	26.06	26.06
Activity Fund		CYBRARY	0.00	0.00	0.00	0.00	0.00	0.00	0.00
Activity Fund		FACULTY POP	2,000.00	0.00	0.00	0.00	1,831.00	169.00	8.45
Activity Fund		MINOOKA ACADEMY	0.00	0.00	0.00	0.00	0.00	0.00	0.00
Activity Fund		PROM	176,800.00	3,150.00	0.00	0.00	126,708.86	50,091.14	28.33
Activity Fund		SCHOLARSHIP	34,000.00	0.00	0.00	0.00	27,000.00	7,000.00	20.59
Activity Fund		ACTIVITIES - DISC GOLF	0.00	0.00	0.00	0.00	0.00	0.00	0.00
Activity Fund		ACTIVITIES - ASL -	600.00	-25.74	608.50	0.00	-1,817.61	1,809.11	301.52
Activity Fund	1119997062	GREEN HOUSE	1,000.00	0.00	0.00	0.00	326.30	673.70	67.37
Activity Fund		FOUNDATION	0.00	0.00	0.00	0.00	0.00	0.00	0.00
Activity Fund		FOUNDATION ASSIST	1,100.00	0.00	0.00	0.00	1,100.00	0.00	0.00
Activity Fund		ACTIVITIES -	2,000.00	0.00	0.00	0.00	1,826.57	173.43	8.67

## Expenditure Report

Fiscal Year: 2023-2024  
Month: March

COUNTY OF GRUNDY SCHOOL DIST 111

Fund Description	Account	Account Description	Revised Budget	MTD Activity	Encumbrance	Pending Activity	Available Funds	Year to Date Activity	Percent of Budget Used
Activity Fund		BAND BOOSTERS	0.00	0.00	0.00	0.00	0.00	0.00	0.00
Activity Fund		CHOIR BOOSTERS	0.00	0.00	0.00	0.00	0.00	0.00	0.00
Activity Fund		COADY SCHOLARSHIP	100,000.00	0.00	0.00	0.00	100,000.00	0.00	0.00
<b>11 - -----</b>			<b>947,900.00</b>	<b>33,212.70</b>	<b>74,338.83</b>	<b>2,124.24</b>	<b>374,685.09</b>	<b>496,751.84</b>	
<b>1 - -----</b>			<b>46,697,558.99</b>	<b>3,520,246.59</b>	<b>671,690.43</b>	<b>73,611.82</b>	<b>13,960,990.65</b>	<b>31,991,266.09</b>	
Operations & Maint		DIST 111 GROUP MEDICAL	205,991.82	6,668.16	0.00	0.00	62,987.90	143,003.92	69.42
Operations & Maint		DIST 111 GROUP DENTAL	10,840.25	748.26	0.00	0.00	5,708.64	5,131.61	47.34
Operations & Maint	22310200	BOARD OF ED-OTHER	0.00	0.00	0.00	0.00	0.00	0.00	0.00
Operations & Maint	22510110	CSBO SALARY	63,586.09	5,298.32	0.00	0.00	15,901.24	47,684.85	74.99
Operations & Maint	22510211	CSBO TRS	7,791.04	0.00	0.00	0.00	3,201.93	4,589.11	58.90
Operations & Maint		CSBO IMRF	0.00	0.00	0.00	0.00	0.00	0.00	212 0.00
Operations & Maint	20-2510-	CSBO SALARY (GTL)	0.00	0.00	0.00	0.00	0.00	0.00	0.00
Operations & Maint	22510222	CSBO GROUP INS	10,928.54	988.76	0.00	0.00	2,499.50	8,429.04	77.13
Operations & Maint		CSBO DENTAL INS	506.27	42.82	0.00	0.00	136.73	369.54	72.99
Operations & Maint	22510332	CSBO MILEAGE	0.00	0.00	0.00	0.00	0.00	0.00	0.00
Operations & Maint	22510640	CSBO DUES/CLINICS	0.00	0.00	0.00	0.00	0.00	0.00	0.00
Operations & Maint	22540100	DIR OF BUILDING/GROUND	0.00	0.00	0.00	0.00	0.00	0.00	0.00
Operations & Maint	22540110	CUSTODIANS SALARY	836,123.52	61,720.50	0.00	0.00	286,855.99	549,267.53	65.69
Operations & Maint	22540111	CUSTODIAN SALARY S.C.	0.00	0.00	0.00	0.00	0.00	0.00	0.00
Operations & Maint	22540130	CUSTODIAN OVERTIME	20,000.00	1,393.33	0.00	0.00	2,575.61	17,424.39	87.12
Operations & Maint	22540131	BUILDING EXTRA PAY	0.00	0.00	0.00	0.00	0.00	0.00	0.00
Operations & Maint	20-2540-	CUSTODIANS SALARY (IC)	0.00	0.00	0.00	0.00	0.00	0.00	0.00
Operations & Maint	22540222	CUSTODIAN GROUP INS	0.00	0.00	0.00	0.00	-108.53	108.53	0.00
Operations & Maint		CUSTODIAN GROUP INS	239,431.61	23,600.40	0.00	0.00	40,062.78	199,368.83	83.27

## Expenditure Report

Fiscal Year: 2023-2024  
Month: March

COUNTY OF GRUNDY SCHOOL DIST 111

Fund Description	Account	Account Description	Revised Budget	MTD Activity	Encumbrance	Pending Activity	Available Funds	Year to Date Activity	Percent of Budget Used
Operations & Maint	20-2540-	CUSTODIAN GROUP INS S.	0.00	0.00	0.00	0.00	0.00	0.00	0.00
Operations & Maint		20 E 2540 2230 00 300	0.00	0.00	0.00	0.00	-4.73	4.73	0.00
Operations & Maint		CUSTODIAN DENTAL	6,909.97	692.10	0.00	0.00	1,017.20	5,892.77	85.28
Operations & Maint	22540303	LAWN CARE &	45,000.00	0.00	0.00	0.00	45,000.00	0.00	0.00
Operations & Maint	22540304	SNOW REMOVAL -	25,000.00	0.00	0.00	0.00	8,440.00	16,560.00	66.24
Operations & Maint	22540305	EXTERMINATING FEES -	3,000.00	200.00	0.00	0.00	1,235.00	1,765.00	58.83
Operations & Maint	225403032	LAWN CARE &	15,000.00	0.00	0.00	0.00	15,000.00	0.00	0.00
Operations & Maint	225403042	SNOW REMOVAL - SOUTH	25,000.00	0.00	0.00	0.00	11,618.25	13,381.75	53.53
Operations & Maint	225403052	EXTERMINATING FEES -	2,500.00	200.00	0.00	0.00	735.00	1,765.00	70.60
Operations & Maint		HVAC - MEDICAL BUILDING	0.00	0.00	0.00	0.00	0.00	0.00	0.00
Operations & Maint		SNOW REMOVAL -	5,000.00	0.00	0.00	0.00	5,000.00	0.00	213 0.00
Operations & Maint		EXTERMINATING FEES -	0.00	0.00	0.00	0.00	0.00	0.00	0.00
Operations & Maint	22540310	CUSTODIAN HEALTH	0.00	0.00	0.00	0.00	0.00	0.00	0.00
Operations & Maint	22540311	CUSTODIAN LICENSE	0.00	0.00	0.00	0.00	0.00	0.00	0.00
Operations & Maint	22540318	ARCH. & ENG. FEES	0.00	0.00	0.00	0.00	0.00	0.00	0.00
Operations & Maint	22540321	DISTRICT OFFICE LEASE	0.00	0.00	0.00	0.00	0.00	0.00	0.00
Operations & Maint	22540320	MINOOKA ACADEMY	20,000.00	1,827.00	0.00	0.00	4,222.60	15,777.40	78.89
Operations & Maint	225403211	GARBAGE - CENTRAL	61,000.00	4,902.07	0.00	0.00	16,434.02	44,565.98	73.06
Operations & Maint	225403212	GARBAGE - SOUTH	81,000.00	5,928.52	0.00	0.00	25,452.78	55,547.22	68.58
Operations & Maint		GARBAGE - MEDICAL	5,000.00	0.00	0.00	0.00	5,000.00	0.00	0.00
Operations & Maint	22540322	PCU LEASES	0.00	0.00	0.00	0.00	0.00	0.00	0.00
Operations & Maint	22540323	BLDG REPAIR/MAINT	100,000.00	-152,263.05	0.00	0.00	59,761.19	40,238.81	40.24
Operations & Maint	22540324	HVAC REPAIRS - CENTRAL	70,000.00	0.00	13,873.00	0.00	20,112.55	36,014.45	51.45
Operations & Maint	225403232	BLDG REPAIR/MAINT	80,000.00	-60,139.35	40,336.73	0.00	3,128.16	36,535.11	45.67

## Expenditure Report

Fiscal Year: 2023-2024  
Month: March

COUNTY OF GRUNDY SCHOOL DIST 111

Fund Description	Account	Account Description	Revised Budget	MTD Activity	Encumbrance	Pending Activity	Available Funds	Year to Date Activity	Percent of Budget Used
Operations & Maint	225403242	HVAC REPAIRS - SOUTH	70,000.00	-29,177.08	0.00	0.00	31,713.94	38,286.06	54.69
Operations & Maint		BLDG REPAIR/MAINT	0.00	0.00	0.00	0.00	-175.00	175.00	0.00
Operations & Maint		HVAC REPAIRS - MEDICAL	0.00	0.00	0.00	0.00	0.00	0.00	0.00
Operations & Maint	22540332	CUSTODIAN MILEAGE	0.00	0.00	0.00	0.00	0.00	0.00	0.00
Operations & Maint	22540340	DISTRICT OFF UTILITIES	0.00	0.00	0.00	0.00	0.00	0.00	0.00
Operations & Maint	22540342	PHONE	95,000.00	7,193.20	0.00	300.00	26,588.27	68,111.73	71.70
Operations & Maint	22540341	MINOOKA ACADEMY	5,000.00	205.72	0.00	0.00	2,683.61	2,316.39	46.33
Operations & Maint	22540370	WATER-SEWER SERVICES	24,000.00	2,639.45	0.00	0.00	7,362.45	16,637.55	69.32
Operations & Maint	225403702	WATER-SEWER SOUTH	61,000.00	3,520.00	0.00	0.00	17,594.84	43,405.16	71.16
Operations & Maint		WATER-SEWER MEDICAL	500.00	0.00	0.00	0.00	348.78	151.22	30.24
Operations & Maint	22540380	UNEMPLOY INSURANCE	0.00	0.00	0.00	0.00	0.00	0.00	214 0.00
Operations & Maint	22540381	WORKERS COMP	0.00	0.00	0.00	0.00	0.00	0.00	0.00
Operations & Maint	22540382	BLDG FLEET INSURANCE	0.00	0.00	0.00	0.00	0.00	0.00	0.00
Operations & Maint	22540391	CONTRACT SERV	175,000.00	1,285.00	0.00	0.00	53,565.57	121,434.43	69.39
Operations & Maint	225403902	CONTRACT SERV S.C.	85,000.00	628.50	0.00	0.00	19,273.22	65,726.78	77.33
Operations & Maint	225403903	SOUTH MAINTENANCE	950,000.00	88,337.50	0.00	2,661.75	130,755.69	816,582.56	85.96
Operations & Maint	225403912	BLDG SECURITY PS	0.00	0.00	0.00	0.00	0.00	0.00	0.00
Operations & Maint	22540392	PRECISION CONTROL -	0.00	0.00	0.00	0.00	0.00	0.00	0.00
Operations & Maint	225403932	SOUTH SITE CROP	0.00	0.00	0.00	0.00	0.00	0.00	0.00
Operations & Maint		CONTRAC SERV MEDICAL	0.00	0.00	0.00	0.00	-125.00	125.00	0.00
Operations & Maint	22540410	BUILDING SUPPLIES	200,000.00	16,335.18	11,131.00	980.00	49,843.71	138,045.29	69.02
Operations & Maint	22540411	GROUND SUPPLIES	125,000.00	2,717.38	0.00	0.00	-8,165.56	133,165.56	106.53
Operations & Maint	225404102	BLDG SUPPLIES SOUTH	85,000.00	12,946.78	8,229.58	162.86	15,923.40	60,684.16	71.39
Operations & Maint	225404122	SOUTH SITE CROP	15,000.00	0.00	0.00	0.00	12,548.66	2,451.34	16.34

## Expenditure Report

Fiscal Year: 2023-2024  
Month: March

COUNTY OF GRUNDY SCHOOL DIST 111

Fund Description	Account	Account Description	Revised Budget	MTD Activity	Encumbrance	Pending Activity	Available Funds	Year to Date Activity	Percent of Budget Used
Operations & Maint		GROUND SUPPLIES	25,000.00	0.00	12,000.00	0.00	12,966.02	33.98	0.14
Operations & Maint		BUILDING SUPPLIES	0.00	0.00	0.00	0.00	0.00	0.00	0.00
Operations & Maint	22540465	NATURAL GAS	85,000.00	12,659.64	0.00	0.00	40,506.02	44,493.98	52.35
Operations & Maint	225404652	NATURAL GAS SOUTH	50,000.00	7,763.18	0.00	0.00	22,120.23	27,879.77	55.76
Operations & Maint		NATURAL GAS MEDICAL	10,000.00	509.83	0.00	0.00	7,167.07	2,832.93	28.33
Operations & Maint	22540466	ELECTRICITY	250,000.00	25,169.92	0.00	0.00	33,063.53	216,936.47	86.77
Operations & Maint	225404662	ELECTRICITY SOUTH	250,000.00	22,074.07	0.00	0.00	26,053.22	223,946.78	89.58
Operations & Maint		ELECTRICITY MEDICAL	10,000.00	601.95	0.00	0.00	5,463.38	4,536.62	45.37
Operations & Maint	22540490	911 SOFTWARE	0.00	0.00	0.00	0.00	0.00	0.00	0.00
Operations & Maint	2254049001	ESSER I GRANT SUPPLIES	0.00	0.00	0.00	0.00	0.00	0.00	0.00
Operations & Maint	2254049002	ESSER II GRANT SUPPLIES	0.00	0.00	0.00	0.00	0.00	0.00	215 0.00
Operations & Maint	2254049003	ESSER III GRANT	0.00	0.00	0.00	0.00	0.00	0.00	0.00
Operations & Maint	22540541	BLDG EQUIPMENT	85,000.00	0.00	0.00	0.00	72,334.50	12,665.50	14.90
Operations & Maint	22540542	WAN EQUIPMENT	0.00	0.00	0.00	0.00	0.00	0.00	0.00
Operations & Maint	22540540	MINOOKA ACADEMY	5,000.00	0.00	0.00	0.00	5,000.00	0.00	0.00
Operations & Maint	225405412	BLDG EQUIPMENT SOUTH	35,000.00	0.00	0.00	0.00	34,410.10	589.90	1.69
Operations & Maint		BLDG EQUIPMENT	0.00	0.00	0.00	0.00	0.00	0.00	0.00
Operations & Maint	22540640	CUSTODIAN CLINIC	0.00	0.00	0.00	0.00	0.00	0.00	0.00
Operations & Maint	22540690	REAL ESTATE TAXES-	7,000.00	0.00	0.00	0.00	7,000.00	0.00	0.00
Operations & Maint		REAL ESTATE TAXES -	0.00	0.00	0.00	0.00	0.00	0.00	0.00
Operations & Maint	2254070001	ESSER II GRANT	0.00	0.00	0.00	0.00	0.00	0.00	0.00
Operations & Maint	2254070003	ESSER III GRANT	0.00	0.00	0.00	0.00	0.00	0.00	0.00
Operations & Maint	22541120	SUMMER CUSTODIAN	25,000.00	0.00	0.00	0.00	5,025.50	19,974.50	79.90
Operations & Maint	22541390	BLDG SECURITY	5,000.00	0.00	0.00	0.00	5,000.00	0.00	0.00

## Expenditure Report

Fiscal Year: 2023-2024  
Month: March

COUNTY OF GRUNDY SCHOOL DIST 111

Fund Description	Account	Account Description	Revised Budget	MTD Activity	Encumbrance	Pending Activity	Available Funds	Year to Date Activity	Percent of Budget Used
Operations & Maint	22541391	BLDG SECURITY/PUR	5,000.00	0.00	0.00	0.00	5,000.00	0.00	0.00
Operations & Maint	225413902	BLDG SECURITY CS	5,000.00	0.00	0.00	0.00	5,000.00	0.00	0.00
Operations & Maint	225413912	BLDG SECURITY PS	5,000.00	0.00	0.00	0.00	5,000.00	0.00	0.00
Operations & Maint		BLDG SECURITY CS	2,500.00	0.00	0.00	0.00	2,500.00	0.00	0.00
Operations & Maint		BLDG SECURITY PS	2,500.00	0.00	0.00	0.00	2,500.00	0.00	0.00
Operations & Maint	22541410	BLDG SECURITY SUPPLIES	7,500.00	0.00	0.00	0.00	7,500.00	0.00	0.00
Operations & Maint	225414102	BLDG SECURITY SUPPLY S	7,500.00	0.00	0.00	0.00	7,500.00	0.00	0.00
Operations & Maint		BLDG SECURITY SUPPLIES	0.00	0.00	0.00	0.00	0.00	0.00	0.00
Operations & Maint	22541540	BLDG SECURITY	25,000.00	0.00	7,395.00	0.00	1,906.20	15,698.80	62.80
Operations & Maint	225415402	BLDG SECURITY EQ	25,000.00	0.00	0.00	0.00	25,000.00	0.00	0.00
Operations & Maint		BLDG SECURITY EQUIP	0.00	0.00	0.00	0.00	0.00	0.00	216 0.00
Operations & Maint	22542530	SITE IMPROVEMENT	65,000.00	0.00	0.00	0.00	65,000.00	0.00	0.00
Operations & Maint	22542531	BLDG IMPROVEMENT	0.00	0.00	0.00	0.00	0.00	0.00	0.00
Operations & Maint	225425302	SITE IMPROVEMNT SOUTH	0.00	0.00	0.00	0.00	0.00	0.00	0.00
Operations & Maint	225425312	BLDG IMPROVEMNT	50,000.00	0.00	0.00	0.00	50,000.00	0.00	0.00
Operations & Maint		SITE IMPROVEMENT	0.00	0.00	0.00	0.00	0.00	0.00	0.00
Operations & Maint		BLDG IMPROVEMENT	0.00	0.00	0.00	0.00	0.00	0.00	0.00
Operations & Maint	22543540	ATHLETIC FIELDS	75,000.00	0.00	0.00	0.00	-5,128.60	80,128.60	106.84
Operations & Maint	2380600	COMMERCIAL LIAB	0.00	0.00	0.00	0.00	0.00	0.00	0.00
Operations & Maint	24140520	GAVC-BUILDING COSTS	0.00	0.00	0.00	0.00	0.00	0.00	0.00
Operations & Maint	24140600	GAVC BUILD EXPENSES	560,314.00	-19,001.29	0.00	0.00	195,001.34	365,312.66	65.20
Operations & Maint	24140620	GAVC NEW BLDG	56,646.00	0.00	0.00	0.00	6,500.01	50,145.99	88.53
Operations & Maint	20-481-222-	IMRF (BMF 3000)	0.00	0.00	0.00	0.00	0.00	0.00	0.00
Operations & Maint	20-481-222-	IMRF (BMF 3000)	0.00	0.00	0.00	0.00	0.00	0.00	0.00

# Expenditure Report

Fiscal Year: 2023-2024  
Month: March

COUNTY OF GRUNDY SCHOOL DIST 111

Fund Description	Account	Account Description	Revised Budget	MTD Activity	Encumbrance	Pending Activity	Available Funds	Year to Date Activity	Percent of Budget Used
Operations & Maint	Interfund	TRANSFERS	0.00	0.00	0.00	0.00	0.00	0.00	0.00
Operations & Maint	28130	TRANS TO TORT	0.00	0.00	0.00	0.00	0.00	0.00	0.00
Operations & Maint	28400	TRANS TO B & I	0.00	0.00	0.00	0.00	0.00	0.00	0.00
Operations & Maint	28800660	TRANS TO CAPITOL	0.00	0.00	0.00	0.00	0.00	0.00	0.00
<b>20 - -----</b>			<b>5,564,069.11</b>	<b>58,216.77</b>	<b>92,965.31</b>	<b>4,104.61</b>	<b>1,651,098.91</b>	<b>3,815,900.28</b>	
<b>2- - -----</b>			<b>5,564,069.11</b>	<b>58,216.77</b>	<b>92,965.31</b>	<b>4,104.61</b>	<b>1,651,098.91</b>	<b>3,815,900.28</b>	
Debt Service Fund or	34190690	DEVELOPMENT	0.00	0.00	0.00	0.00	0.00	0.00	0.00
Debt Service Fund or	35140620	INTEREST ON BONDS-2001	0.00	0.00	0.00	0.00	0.00	0.00	0.00
Debt Service Fund or	35140621	INTEREST ON BONDS-1999	0.00	0.00	0.00	0.00	0.00	0.00	0.00
Debt Service Fund or	35140622	INTEREST ON BONDS-2005	0.00	0.00	0.00	0.00	0.00	0.00	0.00
Debt Service Fund or	35140623	INTEREST ON CONST	0.00	0.00	0.00	0.00	0.00	0.00	217 0.00
Debt Service Fund or	35140624	INTEREST ON VAR RATE	0.00	0.00	0.00	0.00	0.00	0.00	0.00
Debt Service Fund or	35140626	INTEREST ON BONDS-2008	0.00	0.00	0.00	0.00	0.00	0.00	0.00
Debt Service Fund or	35140627	INTEREST ON BONDS 2010	0.00	0.00	0.00	0.00	0.00	0.00	0.00
Debt Service Fund or	35140628	INTEREST ON BONDS -	0.00	0.00	0.00	0.00	0.00	0.00	0.00
Debt Service Fund or	35140629	INTEREST ON BONDS	0.00	0.00	0.00	0.00	0.00	0.00	0.00
Debt Service Fund or	35140630	INTEREST ON BONDS	0.00	0.00	0.00	0.00	0.00	0.00	0.00
Debt Service Fund or	35140625	APPLE LEASE INTEREST	0.00	0.00	0.00	0.00	0.00	0.00	0.00
Debt Service Fund or	35140631	INTEREST ON BONDS 2014	75,175.00	0.00	0.00	0.00	17,000.00	58,175.00	77.39
Debt Service Fund or	35140632	INTEREST ON BONDS -	0.00	0.00	0.00	0.00	0.00	0.00	0.00
Debt Service Fund or	35140633	INTEREST ON BONDS -	365,200.00	0.00	0.00	0.00	182,600.00	182,600.00	50.00
Debt Service Fund or	35140634	INTEREST ON BONDS-	0.00	0.00	0.00	0.00	0.00	0.00	0.00
Debt Service Fund or	35140635	INTEREST ON BONDS-	216,200.00	0.00	0.00	0.00	108,100.00	108,100.00	50.00
Debt Service Fund or	35140636	INTEREST ON BONDS -	16,000.00	0.00	0.00	0.00	0.00	16,000.00	100.00

## Expenditure Report

Fiscal Year: 2023-2024  
Month: March

COUNTY OF GRUNDY SCHOOL DIST 111

Fund Description	Account	Account Description	Revised Budget	MTD Activity	Encumbrance	Pending Activity	Available Funds	Year to Date Activity	Percent of Budget Used
Debt Service Fund or	35140637	INTEREST ON BONDS 2019	468,125.00	0.00	0.00	0.00	198,000.00	270,125.00	57.70
Debt Service Fund or	35146218	INTEREST ON BONDS 2022	307,800.00	0.00	0.00	0.00	153,900.00	153,900.00	50.00
Debt Service Fund or		PAYMENT TO ESCROW	0.00	0.00	0.00	0.00	0.00	0.00	0.00
Debt Service Fund or	35200619	BONDS RETIRED 2011	0.00	0.00	0.00	0.00	0.00	0.00	0.00
Debt Service Fund or	35200620	BONDS RETIRED 2012A	0.00	0.00	0.00	0.00	0.00	0.00	0.00
Debt Service Fund or	35200621	BONDS RETIRED 2012B	0.00	0.00	0.00	0.00	0.00	0.00	0.00
Debt Service Fund or	35200622	BOND RETIRED THROUGH	0.00	0.00	0.00	0.00	0.00	0.00	0.00
Debt Service Fund or	35200610	BONDS RETIRED 2006B	0.00	0.00	0.00	0.00	0.00	0.00	0.00
Debt Service Fund or	35200611	BOND RETIRED-1999	0.00	0.00	0.00	0.00	0.00	0.00	0.00
Debt Service Fund or	35200612	BONDS RETIRED-2005	0.00	0.00	0.00	0.00	0.00	0.00	0.00
Debt Service Fund or	35200613	BOND RETIRED 2006A	0.00	0.00	0.00	0.00	0.00	0.00	218 0.00
Debt Service Fund or	35200614	BOND RETIRED 2010	0.00	0.00	0.00	0.00	0.00	0.00	0.00
Debt Service Fund or	35200615	APPLE LEASE PRINCIPAL	0.00	0.00	0.00	0.00	0.00	0.00	0.00
Debt Service Fund or	35200616	BONDS RETIRED - 2001	0.00	0.00	0.00	0.00	0.00	0.00	0.00
Debt Service Fund or	35200617	BONDS RETIRED	0.00	0.00	0.00	0.00	0.00	0.00	0.00
Debt Service Fund or	35200618	BONDS RETIRED 2008	0.00	0.00	0.00	0.00	0.00	0.00	0.00
Debt Service Fund or	35200629	PRINCIPAL ON BONDS	2,885,000.00	0.00	0.00	0.00	0.00	2,885,000.00	100.00
Debt Service Fund or	35200623	INTEREST PAYMENT ON	0.00	0.00	0.00	0.00	0.00	0.00	0.00
Debt Service Fund or	35300624	PRINCIPAL ON BONDS	800,000.00	0.00	0.00	0.00	0.00	800,000.00	100.00
Debt Service Fund or	35300611	BOND PRINCIPAL	0.00	0.00	0.00	0.00	0.00	0.00	0.00
Debt Service Fund or	35300612	COST OF BOND ISSUANCE	0.00	0.00	0.00	0.00	0.00	0.00	0.00
Debt Service Fund or	35300613	PRINCIPAL ON BOND	0.00	0.00	0.00	0.00	0.00	0.00	0.00
Debt Service Fund or	35300614	PRINCIPAL ON BOND 2008	0.00	0.00	0.00	0.00	0.00	0.00	0.00
Debt Service Fund or	35300615	PRINCIPAL ON BOND 2010	0.00	0.00	0.00	0.00	0.00	0.00	0.00

## Expenditure Report

Fiscal Year: 2023-2024  
Month: March

COUNTY OF GRUNDY SCHOOL DIST 111

Fund Description	Account	Account Description	Revised Budget	MTD Activity	Encumbrance	Pending Activity	Available Funds	Year to Date Activity	Percent of Budget Used
Debt Service Fund or	35300616	PRINCIPAL ON BONDS	0.00	0.00	0.00	0.00	0.00	0.00	0.00
Debt Service Fund or	35300617	PRINCIPAL ON BONDS	0.00	0.00	0.00	0.00	0.00	0.00	0.00
Debt Service Fund or	35300618	PRINCIPAL ON BONDS	0.00	0.00	0.00	0.00	0.00	0.00	0.00
Debt Service Fund or	35300619	PRINCIPAL ON BONDS	1,830,000.00	0.00	0.00	0.00	0.00	1,830,000.00	100.00
Debt Service Fund or	35300620	PRINCIPAL ON BONDS	0.00	0.00	0.00	0.00	0.00	0.00	0.00
Debt Service Fund or	35300621	PRINCIPAL ON BONDS	0.00	0.00	0.00	0.00	0.00	0.00	0.00
Debt Service Fund or	35300622	PRINCIPAL ON BONDS	0.00	0.00	0.00	0.00	0.00	0.00	0.00
Debt Service Fund or	35300623	PRINCIPAL ON BONDS	1,580,000.00	0.00	0.00	0.00	1,580,000.00	0.00	0.00
Debt Service Fund or	3530611013	PRINCIPAL ON BONDS	0.00	0.00	0.00	0.00	0.00	0.00	0.00
Debt Service Fund or	35300712	COMPUTER LEASE	0.00	0.00	0.00	0.00	0.00	0.00	0.00
Debt Service Fund or	35300710	PRINTROOM COPIER	0.00	0.00	0.00	0.00	0.00	0.00	219 0.00
Debt Service Fund or	35300711	OTHER COPIERS LEASE	0.00	0.00	0.00	0.00	0.00	0.00	0.00
Debt Service Fund or	35300714	DISTRICT OFFICE LEASE	0.00	0.00	0.00	0.00	0.00	0.00	0.00
Debt Service Fund or	35300715	MINOOKA ACADEMY	0.00	0.00	0.00	0.00	0.00	0.00	0.00
Debt Service Fund or	353007122	PRINTROOM COPIER	0.00	0.00	0.00	0.00	0.00	0.00	0.00
Debt Service Fund or	353007132	OTHER COPIERS LEASE S.	0.00	0.00	0.00	0.00	0.00	0.00	0.00
Debt Service Fund or	35900318	BOND LEGAL FEES	0.00	0.00	0.00	0.00	0.00	0.00	0.00
Debt Service Fund or	35900319	BOND CLOSING COSTS	0.00	0.00	0.00	0.00	0.00	0.00	0.00
Debt Service Fund or	35900320	BOND PREMIUM ESCROW	0.00	0.00	0.00	0.00	0.00	0.00	0.00
Debt Service Fund or	35900390	SERVICE CHARGE	0.00	500.00	0.00	0.00	-500.00	500.00	0.00
Debt Service Fund or	35900391	REMARKETING AGENT	0.00	0.00	0.00	0.00	0.00	0.00	0.00
Debt Service Fund or	35900611	ESCROW ADJUSTMENTS	0.00	0.00	0.00	0.00	0.00	0.00	0.00
Debt Service Fund or	38990000	OTHER MISC FINANCING	0.00	0.00	0.00	0.00	0.00	0.00	0.00
<b>30 - -----</b>			<b>8,543,500.00</b>	<b>500.00</b>	<b>0.00</b>	<b>0.00</b>	<b>2,239,100.00</b>	<b>6,304,400.00</b>	

## Expenditure Report

Fiscal Year: 2023-2024  
Month: March

COUNTY OF GRUNDY SCHOOL DIST 111

Fund Description	Account	Account Description	Revised Budget	MTD Activity	Encumbrance	Pending Activity	Available Funds	Year to Date Activity	Percent of Budget Used
<b>3- - - - -</b>			<b>8,543,500.00</b>	<b>500.00</b>	<b>0.00</b>	<b>0.00</b>	<b>2,239,100.00</b>	<b>6,304,400.00</b>	
Transportation Fund		DIST 111 GROUP MEDICAL	84,357.37	2,788.91	0.00	0.00	45,279.14	39,078.23	46.32
Transportation Fund		DIST 111 GROUP DENTAL	2,898.37	624.63	0.00	0.00	-1,096.70	3,995.07	137.84
Transportation Fund	42190110	CSBO SALARY	63,586.09	5,298.30	0.00	0.00	15,901.35	47,684.74	74.99
Transportation Fund	42190211	CSBO TRS	7,791.04	0.00	0.00	0.00	3,201.67	4,589.37	58.91
Transportation Fund		CSBO IMRF	0.00	0.00	0.00	0.00	0.00	0.00	0.00
Transportation Fund	40-2190-	CSBO SALARY (GTL)	0.00	0.00	0.00	0.00	0.00	0.00	0.00
Transportation Fund	42190222	CSBO GROUP INS	10,928.81	988.80	0.00	0.00	2,499.53	8,429.28	77.13
Transportation Fund		CSBO DENTAL INS	506.27	42.82	0.00	0.00	136.73	369.54	72.99
Transportation Fund	42190332	CSBO MILEAGE	0.00	0.00	0.00	0.00	0.00	0.00	0.00
Transportation Fund	42190640	CSBO DUES/CLINICS	0.00	0.00	0.00	0.00	0.00	0.00	220 0.00
Transportation Fund		BKKPER GROUP INS	0.00	0.00	0.00	0.00	0.00	0.00	0.00
Transportation Fund		DIST 111 GROUP DENTAL	0.00	0.00	0.00	0.00	0.00	0.00	0.00
Transportation Fund	42310200	BOARD OF ED-OTHER	0.00	0.00	0.00	0.00	0.00	0.00	0.00
Transportation Fund		Transportation Purchase	4,500.00	1,075.00	0.00	0.00	2,948.20	1,551.80	34.48
Transportation Fund	42550110	TRANS SECY SALARY	86,893.58	7,412.80	0.00	0.00	19,427.35	67,466.23	77.64
Transportation Fund	42550111	GAVC/PREMIER ROUTE	0.00	0.00	0.00	0.00	0.00	0.00	0.00
Transportation Fund	42550112	OUT OF DISTRICT ROUTE	545,691.68	44,141.38	0.00	0.00	151,297.39	394,394.29	72.27
Transportation Fund	42550113	REGULAR ROUTE SALARY	622,427.60	39,802.39	0.00	0.00	262,440.45	359,987.15	57.84
Transportation Fund	42550114	BKKPER TRANS SALARY	8,300.00	691.66	0.00	0.00	2,075.04	6,224.96	75.00
Transportation Fund	42550115	OUT OF DISTRICT BUS	107,555.55	7,210.12	0.00	0.00	34,625.80	72,929.75	67.81
Transportation Fund	42550116	SHUTTLE(S)	1,750.67	770.70	0.00	0.00	-7,056.38	8,807.05	503.07
Transportation Fund	42550117	BUS SUBS 201 FOR 111	0.00	0.00	0.00	0.00	0.00	0.00	0.00
Transportation Fund	42550118	IDEA PART B SP ED BUS	0.00	0.00	0.00	0.00	0.00	0.00	0.00

## Expenditure Report

Fiscal Year: 2023-2024  
Month: March

COUNTY OF GRUNDY SCHOOL DIST 111

Fund Description	Account	Account Description	Revised Budget	MTD Activity	Encumbrance	Pending Activity	Available Funds	Year to Date Activity	Percent of Budget Used
Transportation Fund	42550119	FULL TIME DRIVER	93,290.70	5,863.54	0.00	0.00	37,855.54	55,435.16	59.42
Transportation Fund	42550130	EXTRA DUTY (non-drive)	14,577.96	792.42	0.00	0.00	5,627.12	8,950.84	61.40
Transportation Fund	42550131	ACADEMIC TRIP(S)	57,152.03	2,601.78	0.00	0.00	41,249.08	15,902.95	27.83
Transportation Fund	42550132	ATHLETIC/ACTIVITES	81,831.28	4,943.92	0.00	0.00	26,256.11	55,575.17	67.91
Transportation Fund	42550133	ACTIVITIES TRIP	0.00	0.00	0.00	0.00	0.00	0.00	0.00
Transportation Fund		DIRECTOR OF FINANCE	1,016.98	84.74	0.00	0.00	301.26	715.72	70.38
Transportation Fund	42550223	TRANS SEC INSURANCE	0.00	0.00	0.00	0.00	0.00	0.00	0.00
Transportation Fund	42554223	TRANS. DIR. INSURANCE	0.00	0.00	0.00	0.00	0.00	0.00	0.00
Transportation Fund	40-2550-	TRANSPORTATION	52,647.50	5,888.92	0.00	0.00	6,399.46	46,248.04	87.84
Transportation Fund		FT BUS DRIVER GROUP	0.00	0.00	0.00	0.00	0.00	0.00	0.00
Transportation Fund	FULL TIME	FULL TIME DRIVER MED	0.00	0.00	0.00	0.00	0.00	0.00	221 0.00
Transportation Fund		DIR FINANCE TRANS	1,040.16	94.30	0.00	0.00	236.07	804.09	77.30
Transportation Fund		BUS DRIVER GROUP INS	17,050.67	2,788.18	0.00	0.00	-1,587.43	18,638.10	109.31
Transportation Fund		TRANS SEC DENTAL INS	693.64	80.52	0.00	0.00	-1.28	694.92	100.18
Transportation Fund		DIR FINANCE DENTAL INS	0.00	4.02	0.00	0.00	-36.63	36.63	0.00
Transportation Fund	42550230	COURSE	0.00	0.00	0.00	0.00	0.00	0.00	0.00
Transportation Fund	42550310	TRANS HEALTH EXAMS	12,000.00	2,148.00	0.00	0.00	2,042.50	9,957.50	82.98
Transportation Fund	42551310	TANK TESTING	0.00	0.00	0.00	0.00	0.00	0.00	0.00
Transportation Fund	42550320	BUS LEASES	550,000.00	0.00	0.00	0.00	150,880.50	399,119.50	72.57
Transportation Fund	42550321	GARBAGE DISPOSAL	9,000.00	0.00	0.00	0.00	5,270.25	3,729.75	41.44
Transportation Fund	42550322	CLEANING SERVICES	6,500.00	178.81	0.00	0.00	3,301.10	3,198.90	49.21
Transportation Fund	42551322	SNOW REMOVAL-BUS	15,000.00	0.00	0.00	0.00	15,000.00	0.00	0.00
Transportation Fund	42550331	SPECIAL ED TRANS	9,000.00	4,562.36	0.00	0.00	3,148.60	5,851.40	65.02
Transportation Fund	42550332	TRANS MILEAGE	1,000.00	0.00	0.00	0.00	705.16	294.84	29.48

## Expenditure Report

Fiscal Year: 2023-2024  
Month: March

COUNTY OF GRUNDY SCHOOL DIST 111

Fund Description	Account	Account Description	Revised Budget	MTD Activity	Encumbrance	Pending Activity	Available Funds	Year to Date Activity	Percent of Budget Used
Transportation Fund	42550340	PHONE-BUS GARAGE	1,000.00	0.00	0.00	0.00	431.90	568.10	56.81
Transportation Fund	42551340	TRANS POSTAGE	1,000.00	0.00	0.00	0.00	912.00	88.00	8.80
Transportation Fund	42550350	TRANS ADVERTISING	2,500.00	0.00	0.00	0.00	968.03	1,531.97	61.28
Transportation Fund	42550370	WATER-BUS GARAGE	800.00	71.75	0.00	0.00	457.21	342.79	42.85
Transportation Fund	42550380	UNEMPLOY INSURANCE	0.00	0.00	0.00	0.00	0.00	0.00	0.00
Transportation Fund	42550381	WORKERS COMP	0.00	0.00	0.00	0.00	0.00	0.00	0.00
Transportation Fund	42550382	BUS FLEET INSURANCE	0.00	0.00	0.00	0.00	0.00	0.00	0.00
Transportation Fund	42550390	MECHANICS	0.00	0.00	0.00	0.00	0.00	0.00	0.00
Transportation Fund	42550391	ROUTING SOFTWARE	0.00	0.00	0.00	0.00	-14,047.60	14,047.60	0.00
Transportation Fund	42550464	VAN FUEL	38,000.00	1,617.17	0.00	177.34	17,827.75	19,994.91	52.62
Transportation Fund	42550640	TRANS DIR	2,000.00	0.00	0.00	0.00	1,454.34	545.66	22227.28
Transportation Fund	42550690	REFUND ACCOUNT	0.00	0.00	0.00	0.00	0.00	0.00	0.00
Transportation Fund		NON CAPITAL OUTLAY	0.00	0.00	0.00	0.00	0.00	0.00	0.00
Transportation Fund	42552410	OFFICE & NON-REPAIR	25,000.00	2,360.29	0.00	0.00	16,480.55	8,519.45	34.08
Transportation Fund	42552411	BUS & VAN REPAIR	31,000.00	1,982.76	0.00	0.00	9,379.97	21,620.03	69.74
Transportation Fund	42552464	BUS FUEL	315,000.00	21,154.31	0.00	4,644.26	133,731.38	176,624.36	56.07
Transportation Fund	42552465	NATURAL GAS-BUS	3,000.00	0.00	0.00	0.00	1,582.21	1,417.79	47.26
Transportation Fund	42552466	ELECTRICITY-BUS	5,500.00	987.64	0.00	0.00	-1,249.27	6,749.27	122.71
Transportation Fund	42554110	BUS MECHANIC SALARY	108,549.70	5,718.68	0.00	0.00	47,226.91	61,322.79	56.49
Transportation Fund	42554111	TRANS DIRECTORS	84,285.85	12,787.07	0.00	0.00	1,523.44	82,762.41	98.19
Transportation Fund	42554222	BUS MECH GROUP INS	57,586.32	3,089.76	0.00	0.00	21,405.66	36,180.66	62.83
Transportation Fund		TRANS DIRECTORS	23,791.68	3,863.88	0.00	0.00	1,299.60	22,492.08	94.54
Transportation Fund		BUS MECH DENTAL INS	906.72	0.00	0.00	0.00	736.71	170.01	18.75
Transportation Fund		TRANS DIRECTOR DENTAL	453.36	122.96	0.00	0.00	-142.20	595.56	131.37

## Expenditure Report

Fiscal Year: 2023-2024  
Month: March

COUNTY OF GRUNDY SCHOOL DIST 111

Fund Description	Account	Account Description	Revised Budget	MTD Activity	Encumbrance	Pending Activity	Available Funds	Year to Date Activity	Percent of Budget Used
Transportation Fund	42554300	TRANS CONTR SERV	55,000.00	1,592.50	0.00	0.00	47,304.86	7,695.14	13.99
Transportation Fund	42554323	TRANS REPAIR/MAINT	75,000.00	5,595.41	0.00	66,690.02	-37,293.16	45,603.14	60.80
Transportation Fund	42554339	INSPECTION/LICENSE	7,500.00	0.00	0.00	0.00	2,913.00	4,587.00	61.16
Transportation Fund	42554540	TRANS EQUIPMENT	25,000.00	0.00	0.00	0.00	25,000.00	0.00	0.00
Transportation Fund	42554550	TRANS VEHICLES	150,000.00	0.00	0.00	0.00	150,000.00	0.00	0.00
Transportation Fund	42559520	BUS GARAGE ADDITION	0.00	0.00	0.00	0.00	0.00	0.00	0.00
Transportation Fund	42559530	TRANS BLDG IMPROVE	75,000.00	420.37	0.00	0.00	57,860.00	17,140.00	22.85
Transportation Fund	42559690	TRANS - OTHER	0.00	0.00	0.00	0.00	0.00	0.00	0.00
Transportation Fund	40-481-222-	IMRF (BMF 3000)	0.00	0.00	0.00	0.00	0.00	0.00	0.00
Transportation Fund	40-481-222-	IMRF (BMF 3000)	0.00	0.00	0.00	0.00	0.00	0.00	0.00
Transportation Fund		Interfund Transfers	0.00	0.00	0.00	0.00	0.00	0.00	223 0.00
Transportation Fund		TRANSFER AMONG FUNDS	0.00	0.00	0.00	0.00	0.00	0.00	0.00
<b>40 - -----</b>			<b>3,556,861.58</b>	<b>202,243.57</b>	<b>0.00</b>	<b>71,511.62</b>	<b>1,314,090.27</b>	<b>2,171,259.69</b>	
<b>4 - -----</b>			<b>3,556,861.58</b>	<b>202,243.57</b>	<b>0.00</b>	<b>71,511.62</b>	<b>1,314,090.27</b>	<b>2,171,259.69</b>	
I.M.R.F./Soc. Sec. Fund	50-1130-212	TITLE 1 SALARIES	662.31	0.00	0.00	0.00	0.00	662.31	100.00
I.M.R.F./Soc. Sec. Fund	51130212	CAMPUS MONITOR IMRF	23,210.00	2,791.90	0.00	0.00	1,322.02	21,887.98	94.30
I.M.R.F./Soc. Sec. Fund		NURSE IMRF	374.00	42.03	0.00	0.00	92.39	281.61	75.30
I.M.R.F./Soc. Sec. Fund		DEAN SEC IMRF	1,455.38	102.34	0.00	0.00	621.69	833.69	57.28
I.M.R.F./Soc. Sec. Fund		PI IMRF	0.00	0.00	0.00	0.00	0.00	0.00	0.00
I.M.R.F./Soc. Sec. Fund	5113021250	ATH TRAINER IMRF	0.00	0.00	0.00	0.00	0.00	0.00	0.00
I.M.R.F./Soc. Sec. Fund	50-1130-213	TITLE 1 FICA	452.75	0.00	0.00	0.00	0.00	452.75	100.00
I.M.R.F./Soc. Sec. Fund	51130213	CAMPUS MONITOR FICA	13,519.65	1,698.29	0.00	0.00	-114.31	13,633.96	100.85
I.M.R.F./Soc. Sec. Fund		NURSE FICA	303.90	46.96	0.00	0.00	19.40	284.50	93.62
I.M.R.F./Soc. Sec. Fund		DEAN SEC FICA	872.22	69.04	0.00	0.00	305.09	567.13	65.02

## Expenditure Report

Fiscal Year: 2023-2024  
Month: March

COUNTY OF GRUNDY SCHOOL DIST 111

Fund Description	Account	Account Description	Revised Budget	MTD Activity	Encumbrance	Pending Activity	Available Funds	Year to Date Activity	Percent of Budget Used
I.M.R.F./Soc. Sec. Fund		MONITOR FICA	0.00	0.00	0.00	0.00	0.00	0.00	0.00
I.M.R.F./Soc. Sec. Fund		SEC FICA	0.00	0.00	0.00	0.00	0.00	0.00	0.00
I.M.R.F./Soc. Sec. Fund	5113021305	ENGLISH/DRAMA FICA	0.00	0.00	0.00	0.00	0.00	0.00	0.00
I.M.R.F./Soc. Sec. Fund	5113021312	MUSIC SALARY FICA	0.00	0.00	0.00	0.00	0.00	0.00	0.00
I.M.R.F./Soc. Sec. Fund	5113021321	DRIVER ED FICA	0.00	0.00	0.00	0.00	0.00	0.00	0.00
I.M.R.F./Soc. Sec. Fund	50-1130-	INSTR LEADER SALARY	0.00	0.00	0.00	0.00	0.00	0.00	0.00
I.M.R.F./Soc. Sec. Fund	5113021350	ATH TRAINER FICA	0.00	0.00	0.00	0.00	0.00	0.00	0.00
I.M.R.F./Soc. Sec. Fund	50-1130-214	AIDE MEDICARE	726.40	0.00	0.00	0.00	618.36	108.04	14.87
I.M.R.F./Soc. Sec. Fund	51130214	INSTR MEDICARE	4,302.62	546.05	0.00	0.00	-68.51	4,371.13	101.59
I.M.R.F./Soc. Sec. Fund		INSTR MEDICARE	9,562.88	691.18	0.00	0.00	4,378.48	5,184.40	54.21
I.M.R.F./Soc. Sec. Fund		DEAN MEDICARE	1,390.02	105.66	0.00	0.00	433.93	956.09	22468.78
I.M.R.F./Soc. Sec. Fund		INSTR MEDICARE	2.28	0.00	0.00	0.00	-4.77	7.05	309.21
I.M.R.F./Soc. Sec. Fund		INSTR MEDICARE	1,012.20	0.00	0.00	0.00	-524.46	1,536.66	151.81
I.M.R.F./Soc. Sec. Fund		MEDICARE	0.00	0.00	0.00	0.00	0.00	0.00	0.00
I.M.R.F./Soc. Sec. Fund	5113021402	ART MEDICARE	3,675.01	283.98	0.00	0.00	1,142.98	2,532.03	68.90
I.M.R.F./Soc. Sec. Fund	5113021405	ENGLISH/DRAMA	28,986.41	2,193.67	0.00	0.00	9,423.87	19,562.54	67.49
I.M.R.F./Soc. Sec. Fund	5113021406	FOREIGN LANG MEDICARE	13,869.82	956.75	0.00	0.00	4,938.88	8,930.94	64.39
I.M.R.F./Soc. Sec. Fund	5113021411	MATH MEDICARE	23,262.83	1,817.77	0.00	0.00	7,166.36	16,096.47	69.19
I.M.R.F./Soc. Sec. Fund	5113021412	MUSIC MEDICARE	4,231.96	280.26	0.00	0.00	1,680.32	2,551.64	60.29
I.M.R.F./Soc. Sec. Fund	5113021413	NAT SCIENCE MEDICARE	22,567.88	1,619.45	0.00	0.00	7,947.85	14,620.03	64.78
I.M.R.F./Soc. Sec. Fund	5113021415	SOC SCIENCE MEDICARE	21,723.57	1,654.33	0.00	0.00	6,960.53	14,763.04	67.96
I.M.R.F./Soc. Sec. Fund	5113021421	DRIVER ED MEDICARE	0.00	0.00	0.00	0.00	0.00	0.00	0.00
I.M.R.F./Soc. Sec. Fund	5113021427	DEPT CHAIR MEDICARE	12,514.00	920.04	0.00	0.00	4,273.56	8,240.44	65.85
I.M.R.F./Soc. Sec. Fund	5113021450	PHYS ED MEDICARE	19,926.78	1,225.50	0.00	0.00	8,614.73	11,312.05	56.77

## Expenditure Report

Fiscal Year: 2023-2024  
Month: March

COUNTY OF GRUNDY SCHOOL DIST 111

Fund Description	Account	Account Description	Revised Budget	MTD Activity	Encumbrance	Pending Activity	Available Funds	Year to Date Activity	Percent of Budget Used
I.M.R.F./Soc. Sec. Fund	50-1200-	IDEA PART B SP ED	0.00	0.00	0.00	0.00	0.00	0.00	0.00
I.M.R.F./Soc. Sec. Fund	50-1200-	IDEA SP ED LOCAL (RM)	0.00	0.00	0.00	0.00	0.00	0.00	0.00
I.M.R.F./Soc. Sec. Fund		SPEC ED AIDE IMRF	12,872.75	1,042.02	0.00	0.00	2,910.81	9,961.94	77.39
I.M.R.F./Soc. Sec. Fund		SPEC ED SEC IMRF	4,036.56	272.88	0.00	0.00	1,068.31	2,968.25	73.53
I.M.R.F./Soc. Sec. Fund	50-1200-	IDEA PART B SP ED	0.00	0.00	0.00	0.00	0.00	0.00	0.00
I.M.R.F./Soc. Sec. Fund	50-1200-	IDEA SP ED LOCAL (FR)	0.00	0.00	0.00	0.00	0.00	0.00	0.00
I.M.R.F./Soc. Sec. Fund		SPEC ED AIDE FICA	8,286.18	699.94	0.00	0.00	1,561.83	6,724.35	81.15
I.M.R.F./Soc. Sec. Fund		SPEC ED SEC FICA	2,556.58	184.10	0.00	0.00	583.35	1,973.23	77.18
I.M.R.F./Soc. Sec. Fund	50-1200-	SPECIAL ED SALARY	20,505.80	1,613.23	0.00	0.00	6,303.63	14,202.17	69.26
I.M.R.F./Soc. Sec. Fund		SPEC ED MEDICARE	0.00	0.00	0.00	0.00	0.00	0.00	0.00
I.M.R.F./Soc. Sec. Fund		SPEC ED AIDE MEDICARE	1,946.60	163.68	0.00	0.00	374.12	1,572.48	22580.78
I.M.R.F./Soc. Sec. Fund		SPEC ED SEC MEDICARE	597.96	43.06	0.00	0.00	136.42	461.54	77.19
I.M.R.F./Soc. Sec. Fund	51250212	COOP HOMEBOUND/HOSP	0.00	0.00	0.00	0.00	0.00	0.00	0.00
I.M.R.F./Soc. Sec. Fund	51250213	COOP HOMEBOUND/HOSP	0.00	0.00	0.00	0.00	0.00	0.00	0.00
I.M.R.F./Soc. Sec. Fund	51250214	COOP HB/HOSP	0.00	0.00	0.00	0.00	0.00	0.00	0.00
I.M.R.F./Soc. Sec. Fund	50-1400-	CTE SALARY IMRF	0.00	0.00	0.00	0.00	0.00	0.00	0.00
I.M.R.F./Soc. Sec. Fund	51400213	VOC ED GRANT FICA	0.00	0.00	0.00	0.00	0.00	0.00	0.00
I.M.R.F./Soc. Sec. Fund	51400214	VOC ED GRANT MEDICARE	4,717.01	356.07	0.00	0.00	1,540.28	3,176.73	67.35
I.M.R.F./Soc. Sec. Fund	5140021410	IND TECH MEDICARE	3,926.59	274.04	0.00	0.00	1,454.50	2,472.09	62.96
I.M.R.F./Soc. Sec. Fund	5140121401	AG MEDICARE	4,071.35	209.74	0.00	0.00	2,170.49	1,900.86	46.69
I.M.R.F./Soc. Sec. Fund	5140721403	BUSINESS ED MEDICARE	3,856.82	285.14	0.00	0.00	1,306.94	2,549.88	66.11
I.M.R.F./Soc. Sec. Fund	51410214	VIDEO EDIT MEDICARE	0.00	0.00	0.00	0.00	0.00	0.00	0.00
I.M.R.F./Soc. Sec. Fund	5141121430	INST. TECH MEDICARE	1,384.75	103.72	0.00	0.00	460.21	924.54	66.77
I.M.R.F./Soc. Sec. Fund	51417212	ATHLETIC TRAINER IMRF	6,217.62	684.60	0.00	0.00	1,522.32	4,695.30	75.52

## Expenditure Report

Fiscal Year: 2023-2024  
Month: March

COUNTY OF GRUNDY SCHOOL DIST 111

Fund Description	Account	Account Description	Revised Budget	MTD Activity	Encumbrance	Pending Activity	Available Funds	Year to Date Activity	Percent of Budget Used
I.M.R.F./Soc. Sec. Fund	51417213	ATHLETIC TRAINER FICA	3,971.91	449.55	0.00	0.00	867.49	3,104.42	78.16
I.M.R.F./Soc. Sec. Fund	51417214	ATHLETIC TRAINER	928.95	105.13	0.00	0.00	202.92	726.03	78.16
I.M.R.F./Soc. Sec. Fund	5142021409	FAM/CONS SCI MEDICARE	4,132.03	384.81	0.00	0.00	790.11	3,341.92	80.88
I.M.R.F./Soc. Sec. Fund	50-1500-212	INVITATIONAL WKRS (RM)	0.00	0.00	0.00	0.00	0.00	0.00	0.00
I.M.R.F./Soc. Sec. Fund	5150021230	ATHLETIC DIR SECY IMRF	0.00	0.00	0.00	0.00	0.00	0.00	0.00
I.M.R.F./Soc. Sec. Fund		ATHLETIC DIR SECY IMRF	5,650.03	351.70	0.00	0.00	2,512.37	3,137.66	55.53
I.M.R.F./Soc. Sec. Fund		ATHLETIC IMRF	3,067.76	28.67	0.00	0.00	569.58	2,498.18	81.43
I.M.R.F./Soc. Sec. Fund		ATH/ACT	0.00	32.10	0.00	0.00	-238.82	238.82	0.00
I.M.R.F./Soc. Sec. Fund		ATH/ACT	623.19	82.14	0.00	0.00	-47.20	670.39	107.57
I.M.R.F./Soc. Sec. Fund		ATH/ACT	156.77	46.94	0.00	0.00	-212.10	368.87	235.29
I.M.R.F./Soc. Sec. Fund		TECH DIR IMRF	536.05	50.10	0.00	0.00	89.11	446.94	22683.38
I.M.R.F./Soc. Sec. Fund		ATH/ACT	0.00	0.00	0.00	0.00	0.00	0.00	0.00
I.M.R.F./Soc. Sec. Fund		ATH/ACT	1,017.53	77.48	0.00	0.00	221.81	795.72	78.20
I.M.R.F./Soc. Sec. Fund	51500212	MAIN OFFICE IMRF	0.00	0.00	0.00	0.00	0.00	0.00	0.00
I.M.R.F./Soc. Sec. Fund	5150021270	ACTIVITY DIR SECY IMRF	5,088.82	396.16	0.00	0.00	1,554.41	3,534.41	69.45
I.M.R.F./Soc. Sec. Fund		ATH/ACT	0.00	0.00	0.00	0.00	0.00	0.00	0.00
I.M.R.F./Soc. Sec. Fund		ATH/ACT	873.68	105.73	0.00	0.00	343.29	530.39	60.71
I.M.R.F./Soc. Sec. Fund		ATH/ACT	0.00	0.00	0.00	0.00	0.00	0.00	0.00
I.M.R.F./Soc. Sec. Fund		ATH/ACT	0.00	0.00	0.00	0.00	0.00	0.00	0.00
I.M.R.F./Soc. Sec. Fund		ATH/ACT	271.28	23.22	0.00	0.00	64.10	207.18	76.37
I.M.R.F./Soc. Sec. Fund		ATH/ACT	185.79	0.00	0.00	0.00	17.43	168.36	90.62
I.M.R.F./Soc. Sec. Fund		ATH/ACT	169.42	15.16	0.00	0.00	35.45	133.97	79.08
I.M.R.F./Soc. Sec. Fund	50-1500-213	INVITATIONAL WKRS (FR)	0.00	0.00	0.00	0.00	0.00	0.00	0.00
I.M.R.F./Soc. Sec. Fund	5150021330	GOLF COACH FICA	0.00	0.00	0.00	0.00	0.00	0.00	0.00

## Expenditure Report

Fiscal Year: 2023-2024  
Month: March

COUNTY OF GRUNDY SCHOOL DIST 111

Fund Description	Account	Account Description	Revised Budget	MTD Activity	Encumbrance	Pending Activity	Available Funds	Year to Date Activity	Percent of Budget Used
I.M.R.F./Soc. Sec. Fund		ATH/ACT	3,482.74	227.80	0.00	0.00	1,431.63	2,051.11	58.89
I.M.R.F./Soc. Sec. Fund		ATH/ACT	1,979.84	19.35	0.00	0.00	285.32	1,694.52	85.59
I.M.R.F./Soc. Sec. Fund		ATH/ACT	695.94	0.00	0.00	0.00	695.94	0.00	0.00
I.M.R.F./Soc. Sec. Fund		ATH/ACT	0.00	21.66	0.00	0.00	-162.40	162.40	0.00
I.M.R.F./Soc. Sec. Fund		ATH/ACT	0.00	0.00	0.00	0.00	0.00	0.00	0.00
I.M.R.F./Soc. Sec. Fund		ATH/ACT	793.03	0.00	0.00	0.00	-457.72	1,250.75	157.72
I.M.R.F./Soc. Sec. Fund		ATH/ACT	0.00	0.00	0.00	0.00	0.00	0.00	0.00
I.M.R.F./Soc. Sec. Fund		ATH/ACT	405.33	55.44	0.00	0.00	-50.89	456.22	112.56
I.M.R.F./Soc. Sec. Fund		ATH/ACT	1,010.74	31.66	0.00	0.00	94.94	915.80	90.61
I.M.R.F./Soc. Sec. Fund		ATH/ACT	296.74	0.00	0.00	0.00	296.74	0.00	0.00
I.M.R.F./Soc. Sec. Fund		ATH/ACT	350.32	33.80	0.00	0.00	46.15	304.17	22786.83
I.M.R.F./Soc. Sec. Fund		ATH/ACT	2,090.23	0.00	0.00	0.00	299.51	1,790.72	85.67
I.M.R.F./Soc. Sec. Fund		ATH/ACT	997.23	0.00	0.00	0.00	-0.65	997.88	100.07
I.M.R.F./Soc. Sec. Fund		ATH/ACT	356.07	0.00	0.00	0.00	42.95	313.12	87.94
I.M.R.F./Soc. Sec. Fund		ATH/ACT	270.62	0.00	0.00	0.00	-11.90	282.52	104.40
I.M.R.F./Soc. Sec. Fund		50 E 1500 2130 30 300	161.85	0.00	0.00	0.00	161.85	0.00	0.00
I.M.R.F./Soc. Sec. Fund		ATH/ACT	647.37	0.00	0.00	0.00	647.37	0.00	0.00
I.M.R.F./Soc. Sec. Fund		ATH/ACT	800.01	0.00	0.00	0.00	800.01	0.00	0.00
I.M.R.F./Soc. Sec. Fund		ATH/ACT	896.47	52.28	0.00	0.00	354.57	541.90	60.45
I.M.R.F./Soc. Sec. Fund		50 E 1500 2130 30 300	0.00	158.32	0.00	0.00	-316.64	316.64	0.00
I.M.R.F./Soc. Sec. Fund	51500213	MAIN OFFICE FICA	0.00	0.00	0.00	0.00	0.00	0.00	0.00
I.M.R.F./Soc. Sec. Fund	5150021370	ACTIVITIES FICA	3,442.64	248.76	0.00	0.00	1,064.05	2,378.59	69.09
I.M.R.F./Soc. Sec. Fund		ATH/ACT	0.00	0.00	0.00	0.00	0.00	0.00	0.00
I.M.R.F./Soc. Sec. Fund		ATH/ACT	620.36	71.35	0.00	0.00	262.35	358.01	57.71

## Expenditure Report

Fiscal Year: 2023-2024  
Month: March

COUNTY OF GRUNDY SCHOOL DIST 111

Fund Description	Account	Account Description	Revised Budget	MTD Activity	Encumbrance	Pending Activity	Available Funds	Year to Date Activity	Percent of Budget Used
I.M.R.F./Soc. Sec. Fund		ATH/ACT	0.00	0.00	0.00	0.00	0.00	0.00	0.00
I.M.R.F./Soc. Sec. Fund		50 E 1500 2130 70 300	0.00	111.60	0.00	0.00	-111.60	111.60	0.00
I.M.R.F./Soc. Sec. Fund		ATH/ACT	157.25	0.00	0.00	0.00	157.25	0.00	0.00
I.M.R.F./Soc. Sec. Fund		ATH/ACT	425.57	0.00	0.00	0.00	-403.56	829.13	194.83
I.M.R.F./Soc. Sec. Fund		50 E 1500 2130 70 300	0.00	149.86	0.00	0.00	-149.86	149.86	0.00
I.M.R.F./Soc. Sec. Fund		ATH/ACT	115.81	111.60	0.00	0.00	4.21	111.60	96.36
I.M.R.F./Soc. Sec. Fund		ATH/ACT	127.38	0.00	0.00	0.00	127.38	0.00	0.00
I.M.R.F./Soc. Sec. Fund		ATH/ACT	195.05	0.00	0.00	0.00	101.07	93.98	48.18
I.M.R.F./Soc. Sec. Fund		ATH/ACT	142.95	0.00	0.00	0.00	142.95	0.00	0.00
I.M.R.F./Soc. Sec. Fund		ATH/ACT	177.39	15.66	0.00	0.00	36.44	140.95	79.46
I.M.R.F./Soc. Sec. Fund		ATH/ACT	248.47	0.00	0.00	0.00	16.20	232.27	22893.48
I.M.R.F./Soc. Sec. Fund		ATH/ACT	138.96	0.00	0.00	0.00	138.96	0.00	0.00
I.M.R.F./Soc. Sec. Fund		ATH/ACT	446.57	0.00	0.00	0.00	322.32	124.25	27.82
I.M.R.F./Soc. Sec. Fund		50 E 1500 2130 70 300	111.55	10.23	0.00	0.00	20.29	91.26	81.81
I.M.R.F./Soc. Sec. Fund	50-1500-214	INVITATIONAL WKRS (MR)	0.00	0.00	0.00	0.00	0.00	0.00	0.00
I.M.R.F./Soc. Sec. Fund	5150021530	ASST ATHLETIC DIR	0.00	0.00	0.00	0.00	0.00	0.00	0.00
I.M.R.F./Soc. Sec. Fund	50-1500-	ASST ATHLETIC DIR	0.00	0.00	0.00	0.00	0.00	0.00	0.00
I.M.R.F./Soc. Sec. Fund	5150021430	ATHLETIC MEDICARE	3,668.80	122.50	0.00	0.00	2,578.78	1,090.02	29.71
I.M.R.F./Soc. Sec. Fund		ATH/ACT	1,069.18	60.04	0.00	0.00	384.82	684.36	64.01
I.M.R.F./Soc. Sec. Fund		ATH/ACT	1,485.13	38.34	0.00	0.00	358.40	1,126.73	75.87
I.M.R.F./Soc. Sec. Fund		ATH/ACT	216.24	16.12	0.00	0.00	72.64	143.60	66.41
I.M.R.F./Soc. Sec. Fund		ATH/ACT	605.87	21.32	0.00	0.00	416.92	188.95	31.19
I.M.R.F./Soc. Sec. Fund		ATH/ACT	213.48	18.64	0.00	0.00	50.11	163.37	76.53
I.M.R.F./Soc. Sec. Fund		ATH/ACT	530.61	78.99	0.00	0.00	123.17	407.44	76.79

## Expenditure Report

Fiscal Year: 2023-2024  
Month: March

COUNTY OF GRUNDY SCHOOL DIST 111

Fund Description	Account	Account Description	Revised Budget	MTD Activity	Encumbrance	Pending Activity	Available Funds	Year to Date Activity	Percent of Budget Used
I.M.R.F./Soc. Sec. Fund		ATH/ACT	316.43	36.94	0.00	0.00	7.40	309.03	97.66
I.M.R.F./Soc. Sec. Fund		ATH/ACT	525.67	31.27	0.00	0.00	97.25	428.42	81.50
I.M.R.F./Soc. Sec. Fund		ATH/ACT	446.93	38.70	0.00	0.00	110.23	336.70	75.34
I.M.R.F./Soc. Sec. Fund		ATH/ACT	1,235.53	88.19	0.00	0.00	168.16	1,067.37	86.39
I.M.R.F./Soc. Sec. Fund		ATH/ACT	710.57	49.66	0.00	0.00	268.36	442.21	62.23
I.M.R.F./Soc. Sec. Fund		ATH/ACT	520.77	41.64	0.00	0.00	156.18	364.59	70.01
I.M.R.F./Soc. Sec. Fund		ATH/ACT	537.42	30.10	0.00	0.00	122.22	415.20	77.26
I.M.R.F./Soc. Sec. Fund		ATH/ACT	219.70	19.95	0.00	0.00	157.24	62.46	28.43
I.M.R.F./Soc. Sec. Fund		ATH/ACT	381.28	35.94	0.00	0.00	68.52	312.76	82.03
I.M.R.F./Soc. Sec. Fund		ATH/ACT	488.85	0.00	0.00	0.00	70.05	418.80	85.67
I.M.R.F./Soc. Sec. Fund		ATH/ACT	555.38	10.12	0.00	0.00	102.55	452.83	22981.54
I.M.R.F./Soc. Sec. Fund		ATH/ACT	612.78	20.98	0.00	0.00	89.08	523.70	85.46
I.M.R.F./Soc. Sec. Fund		ATH/ACT	189.67	9.48	0.00	0.00	39.08	150.59	79.40
I.M.R.F./Soc. Sec. Fund		ATH/ACT	156.97	9.82	0.00	0.00	66.74	90.23	57.48
I.M.R.F./Soc. Sec. Fund		ATH/ACT	598.11	44.28	0.00	0.00	213.16	384.95	64.36
I.M.R.F./Soc. Sec. Fund		ATH/ACT	542.39	37.76	0.00	0.00	219.97	322.42	59.44
I.M.R.F./Soc. Sec. Fund		ATH/ACT	235.44	6.64	0.00	0.00	179.64	55.80	23.70
I.M.R.F./Soc. Sec. Fund		ATH/ACT	209.75	12.22	0.00	0.00	83.06	126.69	60.40
I.M.R.F./Soc. Sec. Fund		ATH/ACT	212.30	57.60	0.00	0.00	-43.66	255.96	120.57
I.M.R.F./Soc. Sec. Fund		ATH/ACT	182.25	16.74	0.00	0.00	33.03	149.22	81.88
I.M.R.F./Soc. Sec. Fund	5150021470	ACTIVITIES MEDICARE	1,733.08	130.26	0.00	0.00	571.23	1,161.85	67.04
I.M.R.F./Soc. Sec. Fund		ATH/ACT	874.04	63.55	0.00	0.00	259.84	614.20	70.27
I.M.R.F./Soc. Sec. Fund		ATH/ACT	388.39	30.09	0.00	0.00	121.79	266.60	68.64
I.M.R.F./Soc. Sec. Fund		ATH/ACT	352.28	40.41	0.00	0.00	115.41	236.87	67.24

## Expenditure Report

Fiscal Year: 2023-2024  
Month: March

COUNTY OF GRUNDY SCHOOL DIST 111

Fund Description	Account	Account Description	Revised Budget	MTD Activity	Encumbrance	Pending Activity	Available Funds	Year to Date Activity	Percent of Budget Used
I.M.R.F./Soc. Sec. Fund		ATH/ACT	87.59	6.71	0.00	0.00	27.98	59.61	68.06
I.M.R.F./Soc. Sec. Fund		ATH/ACT	212.29	12.14	0.00	0.00	58.91	153.38	72.25
I.M.R.F./Soc. Sec. Fund		ATH/ACT	103.61	7.28	0.00	0.00	39.62	63.99	61.76
I.M.R.F./Soc. Sec. Fund		ATH/ACT	11.78	2.17	0.00	0.00	-6.05	17.83	151.36
I.M.R.F./Soc. Sec. Fund		ATH/ACT	42.41	3.18	0.00	0.00	14.06	28.35	66.85
I.M.R.F./Soc. Sec. Fund		ATH/ACT	359.63	54.34	0.00	0.00	83.68	275.95	76.73
I.M.R.F./Soc. Sec. Fund		ATH/ACT	170.74	12.66	0.00	0.00	57.88	112.86	66.10
I.M.R.F./Soc. Sec. Fund		ATH/ACT	169.47	12.24	0.00	0.00	61.14	108.33	63.92
I.M.R.F./Soc. Sec. Fund		ATH/ACT	92.95	9.64	0.00	0.00	10.91	82.04	88.26
I.M.R.F./Soc. Sec. Fund		ATH/ACT	110.13	7.66	0.00	0.00	41.89	68.24	61.96
I.M.R.F./Soc. Sec. Fund		ATH/ACT	299.17	23.36	0.00	0.00	90.81	208.36	23069.65
I.M.R.F./Soc. Sec. Fund		ATH/ACT	6.95	0.00	0.00	0.00	6.95	0.00	0.00
I.M.R.F./Soc. Sec. Fund		ATH/ACT	151.29	4.28	0.00	0.00	113.48	37.81	24.99
I.M.R.F./Soc. Sec. Fund		ATH/ACT	40.04	3.22	0.00	0.00	11.60	28.44	71.03
I.M.R.F./Soc. Sec. Fund		ATH/ACT	125.77	10.00	0.00	0.00	37.58	88.19	70.12
I.M.R.F./Soc. Sec. Fund		ATH/ACT	7.01	0.00	0.00	0.00	7.01	0.00	0.00
I.M.R.F./Soc. Sec. Fund		ATH/ACT	62.27	4.66	0.00	0.00	20.70	41.57	66.76
I.M.R.F./Soc. Sec. Fund		ATH/ACT	38.04	2.83	0.00	0.00	12.85	25.19	66.22
I.M.R.F./Soc. Sec. Fund		ATH/ACT	199.88	5.02	0.00	0.00	130.46	69.42	34.73
I.M.R.F./Soc. Sec. Fund		ATH/ACT	92.61	7.12	0.00	0.00	29.49	63.12	68.16
I.M.R.F./Soc. Sec. Fund		ATH/ACT	135.82	3.34	0.00	0.00	-86.93	222.75	164.00
I.M.R.F./Soc. Sec. Fund		ATH/ACT	23.79	3.70	0.00	0.00	-7.04	30.83	129.59
I.M.R.F./Soc. Sec. Fund		ATH/ACT	50.62	3.76	0.00	0.00	17.11	33.51	66.20
I.M.R.F./Soc. Sec. Fund		ATH/ACT	49.76	3.70	0.00	0.00	16.79	32.97	66.26

## Expenditure Report

Fiscal Year: 2023-2024  
Month: March

COUNTY OF GRUNDY SCHOOL DIST 111

Fund Description	Account	Account Description	Revised Budget	MTD Activity	Encumbrance	Pending Activity	Available Funds	Year to Date Activity	Percent of Budget Used
I.M.R.F./Soc. Sec. Fund		ATH/ACT	103.87	12.42	0.00	0.00	-0.16	104.03	100.15
I.M.R.F./Soc. Sec. Fund		ATH/ACT	49.76	3.70	0.00	0.00	16.79	32.97	66.26
I.M.R.F./Soc. Sec. Fund		ATH/ACT	43.26	35.05	0.00	0.00	8.20	35.06	81.04
I.M.R.F./Soc. Sec. Fund		ATH/ACT	68.87	5.10	0.00	0.00	23.49	45.38	65.89
I.M.R.F./Soc. Sec. Fund		ATH/ACT	28.02	0.00	0.00	0.00	25.56	2.46	8.78
I.M.R.F./Soc. Sec. Fund		ATH/ACT	27.08	26.10	0.00	0.00	0.98	26.10	96.38
I.M.R.F./Soc. Sec. Fund		ATH/ACT	31.74	2.40	0.00	0.00	10.37	21.37	67.33
I.M.R.F./Soc. Sec. Fund		ATH/ACT	29.79	0.00	0.00	0.00	29.79	0.00	0.00
I.M.R.F./Soc. Sec. Fund		ATH/ACT	35.28	2.84	0.00	0.00	10.31	24.97	70.78
I.M.R.F./Soc. Sec. Fund		ATH/ACT	82.39	6.16	0.00	0.00	27.44	54.95	66.69
I.M.R.F./Soc. Sec. Fund		ATH/ACT	141.80	7.24	0.00	0.00	55.29	86.51	23161.01
I.M.R.F./Soc. Sec. Fund		ATH/ACT	35.15	2.82	0.00	0.00	10.29	24.86	70.73
I.M.R.F./Soc. Sec. Fund		ATH/ACT	79.05	3.34	0.00	0.00	54.00	25.05	31.69
I.M.R.F./Soc. Sec. Fund		ATH/ACT	51.83	5.84	0.00	0.00	-0.52	52.35	101.00
I.M.R.F./Soc. Sec. Fund		ATH/ACT	42.75	3.22	0.00	0.00	14.05	28.70	67.13
I.M.R.F./Soc. Sec. Fund		ATH/ACT	742.85	0.00	0.00	0.00	151.60	591.25	79.59
I.M.R.F./Soc. Sec. Fund		ATH/ACT	32.51	0.00	0.00	0.00	32.51	0.00	0.00
I.M.R.F./Soc. Sec. Fund		ATH/ACT	46.40	3.50	0.00	0.00	15.23	31.17	67.18
I.M.R.F./Soc. Sec. Fund		ATH/ACT	104.45	6.66	0.00	0.00	25.44	79.01	75.64
I.M.R.F./Soc. Sec. Fund		ATH/ACT	28.50	0.00	0.00	0.00	25.76	2.74	9.61
I.M.R.F./Soc. Sec. Fund		ATH/ACT	131.37	8.92	0.00	0.00	51.87	79.50	60.52
I.M.R.F./Soc. Sec. Fund		ATH/ACT	47.59	4.58	0.00	0.00	7.15	40.44	84.98
I.M.R.F./Soc. Sec. Fund		ATH/ACT	26.11	2.40	0.00	0.00	4.73	21.38	81.88
I.M.R.F./Soc. Sec. Fund		ATH/ACT	56.84	4.82	0.00	0.00	13.43	43.41	76.37

## Expenditure Report

Fiscal Year: 2023-2024  
Month: March

COUNTY OF GRUNDY SCHOOL DIST 111

Fund Description	Account	Account Description	Revised Budget	MTD Activity	Encumbrance	Pending Activity	Available Funds	Year to Date Activity	Percent of Budget Used
I.M.R.F./Soc. Sec. Fund		ATH/ACT	26.10	2.62	0.00	0.00	3.07	23.03	88.24
I.M.R.F./Soc. Sec. Fund		ATH/ACT	23.79	2.18	0.00	0.00	4.35	19.44	81.72
I.M.R.F./Soc. Sec. Fund		ATH/ACT	35.12	3.22	0.00	0.00	6.41	28.71	81.75
I.M.R.F./Soc. Sec. Fund		ATH/ACT	32.11	2.96	0.00	0.00	5.74	26.37	82.12
I.M.R.F./Soc. Sec. Fund		ATH/ACT	0.00	6.66	0.00	0.00	-49.96	49.96	0.00
I.M.R.F./Soc. Sec. Fund	50-1600-	SUMMER SCHOOL SALARY	0.00	0.00	0.00	0.00	0.00	0.00	0.00
I.M.R.F./Soc. Sec. Fund	50-1600-	SUMMER SCHOOL SALARY	0.00	0.00	0.00	0.00	0.00	0.00	0.00
I.M.R.F./Soc. Sec. Fund	51600214	SUMMER SCHOOL	0.00	0.00	0.00	0.00	0.00	0.00	0.00
I.M.R.F./Soc. Sec. Fund	50-1700-	SUMMER DR ED SALARY	0.00	0.00	0.00	0.00	0.00	0.00	0.00
I.M.R.F./Soc. Sec. Fund	50-1700-	SUMMER DR ED SALARY	0.00	0.00	0.00	0.00	0.00	0.00	0.00
I.M.R.F./Soc. Sec. Fund	5170021430	SUMMER DR ED	507.65	0.00	0.00	0.00	479.49	28.16	232 5.55
I.M.R.F./Soc. Sec. Fund	5170021421	DRIVER ED MEDICARE	7,295.13	535.51	0.00	0.00	2,505.75	4,789.38	65.65
I.M.R.F./Soc. Sec. Fund	51900212	MINOOKA ACADEMY SECY	0.00	0.00	0.00	0.00	0.00	0.00	0.00
I.M.R.F./Soc. Sec. Fund		MINOOKA ACADEMY SECY	3,862.55	284.10	0.00	0.00	1,359.76	2,502.79	64.80
I.M.R.F./Soc. Sec. Fund	51900213	MINOOKA ACADEMY SECY	0.00	0.00	0.00	0.00	0.00	0.00	0.00
I.M.R.F./Soc. Sec. Fund		MINOOKA ACADEMY SECY	2,241.75	172.42	0.00	0.00	711.72	1,530.03	68.25
I.M.R.F./Soc. Sec. Fund	51900214	MINOOKA ACADEMY	1,738.51	130.41	0.00	0.00	576.48	1,162.03	66.84
I.M.R.F./Soc. Sec. Fund		MINOOKA ACADEMY SECY	524.33	40.32	0.00	0.00	166.51	357.82	68.24
I.M.R.F./Soc. Sec. Fund	50-2100-	MAIN OFFICE SECY	0.00	0.00	0.00	0.00	0.00	0.00	0.00
I.M.R.F./Soc. Sec. Fund		MAIN OFFICE SECY	4,066.26	315.18	0.00	0.00	1,358.03	2,708.23	66.60
I.M.R.F./Soc. Sec. Fund	521002121	MINOOKA ACADEMY DIR	0.00	0.00	0.00	0.00	0.00	0.00	0.00
I.M.R.F./Soc. Sec. Fund	50-2100-	DIR OF STUDENT SERV	0.00	0.00	0.00	0.00	0.00	0.00	0.00
I.M.R.F./Soc. Sec. Fund	50-2100-	MAIN OFFICE SECY	0.00	0.00	0.00	0.00	0.00	0.00	0.00
I.M.R.F./Soc. Sec. Fund		MAIN OFFICE SECY	2,570.74	212.62	0.00	0.00	735.63	1,835.11	71.38

## Expenditure Report

Fiscal Year: 2023-2024  
Month: March

COUNTY OF GRUNDY SCHOOL DIST 111

Fund Description	Account	Account Description	Revised Budget	MTD Activity	Encumbrance	Pending Activity	Available Funds	Year to Date Activity	Percent of Budget Used
I.M.R.F./Soc. Sec. Fund	521002131	MINOOKA ACADEMY DIR	0.00	0.00	0.00	0.00	0.00	0.00	0.00
I.M.R.F./Soc. Sec. Fund	50-2100-	DIR OF STUDENT SERV	0.00	0.00	0.00	0.00	0.00	0.00	0.00
I.M.R.F./Soc. Sec. Fund	52100214	ASST PRIN-LEARN MED	0.00	0.00	0.00	0.00	0.00	0.00	0.00
I.M.R.F./Soc. Sec. Fund		MAIN OFFICE SECY	601.38	49.74	0.00	0.00	172.11	429.27	71.38
I.M.R.F./Soc. Sec. Fund	50-2100-	DIR STUDENT SERV. SA	2,138.75	171.58	0.00	0.00	591.92	1,546.83	72.32
I.M.R.F./Soc. Sec. Fund	52100215	DIR OF STUD SER	0.00	0.00	0.00	0.00	0.00	0.00	0.00
I.M.R.F./Soc. Sec. Fund	50-2110-212	TITLE 1 SALARIES IMRF	0.00	0.00	0.00	0.00	0.00	0.00	0.00
I.M.R.F./Soc. Sec. Fund	50-2110-213	TITLE 1 SALARIES FICA	0.00	0.00	0.00	0.00	0.00	0.00	0.00
I.M.R.F./Soc. Sec. Fund	50-2110-214	TITLE 1 SALARIES	340.90	18.27	0.00	0.00	-61.38	402.28	118.01
I.M.R.F./Soc. Sec. Fund	52113214	SOCIAL WORKER	3,938.81	376.02	0.00	0.00	690.07	3,248.74	82.48
I.M.R.F./Soc. Sec. Fund	50-2120-	GUIDANCE SALARY (RM)	0.00	0.00	0.00	0.00	0.00	0.00	233 0.00
I.M.R.F./Soc. Sec. Fund	50-2120-	GUIDANCE SALARY (FR)	0.00	0.00	0.00	0.00	0.00	0.00	0.00
I.M.R.F./Soc. Sec. Fund		50 E 2120 2130 00 300	0.00	0.00	0.00	0.00	0.00	0.00	0.00
I.M.R.F./Soc. Sec. Fund	52120214	GUIDANCE MEDICARE	8,018.75	614.80	0.00	0.00	2,498.00	5,520.75	68.85
I.M.R.F./Soc. Sec. Fund		ESSER MEDICARE	1,573.96	0.00	0.00	0.00	1,484.13	89.83	5.71
I.M.R.F./Soc. Sec. Fund	521252120	REGISTRAR IMRF	5,082.06	378.57	0.00	0.00	1,448.21	3,633.85	71.50
I.M.R.F./Soc. Sec. Fund	521252121	STDNT CENTER IMRF	4,461.18	388.80	0.00	0.00	1,050.30	3,410.88	76.46
I.M.R.F./Soc. Sec. Fund	521252122	ASST REGISTRAR IMRF S.	3,622.51	295.84	0.00	0.00	983.23	2,639.28	72.86
I.M.R.F./Soc. Sec. Fund	52125213	REGISTRAR FICA	2,954.06	227.59	0.00	0.00	728.50	2,225.56	75.34
I.M.R.F./Soc. Sec. Fund	521252131	STDNT CENTER FICA	2,828.87	246.92	0.00	0.00	602.92	2,225.95	78.69
I.M.R.F./Soc. Sec. Fund	521252132	ASST REGISTRAR FICA S.	2,262.76	187.28	0.00	0.00	573.01	1,689.75	74.68
I.M.R.F./Soc. Sec. Fund	52125214	REGISTRAR MEDICARE	690.90	53.22	0.00	0.00	170.44	520.46	75.33
I.M.R.F./Soc. Sec. Fund		ACAD RESOURCE CTR	661.50	57.76	0.00	0.00	140.85	520.65	78.71
I.M.R.F./Soc. Sec. Fund		ASST REGISTRAR	529.19	43.80	0.00	0.00	134.00	395.19	74.68

## Expenditure Report

Fiscal Year: 2023-2024  
Month: March

COUNTY OF GRUNDY SCHOOL DIST 111

Fund Description	Account	Account Description	Revised Budget	MTD Activity	Encumbrance	Pending Activity	Available Funds	Year to Date Activity	Percent of Budget Used
I.M.R.F./Soc. Sec. Fund	52134212	NURSE IMRF	5,644.40	287.66	0.00	0.00	2,737.43	2,906.97	51.50
I.M.R.F./Soc. Sec. Fund	521342122	NURSE IMRF S.C.	7,729.80	798.68	0.00	0.00	2,006.34	5,723.46	74.04
I.M.R.F./Soc. Sec. Fund	52134213	NURSE FICA	3,674.96	194.08	0.00	0.00	1,695.44	1,979.52	53.87
I.M.R.F./Soc. Sec. Fund	521342132	NURSE FICA S.C.	5,039.06	538.81	0.00	0.00	1,145.98	3,893.08	77.26
I.M.R.F./Soc. Sec. Fund	50-2134-	NURSE SALARY (MR)	839.53	45.38	0.00	0.00	376.63	462.90	55.14
I.M.R.F./Soc. Sec. Fund	50-2134-	NURSE SALARY S.C. (MR)	1,178.40	126.00	0.00	0.00	268.05	910.35	77.25
I.M.R.F./Soc. Sec. Fund	50-2140-214	PSYCHOLOGIST SALARY	2,728.73	196.40	0.00	0.00	962.53	1,766.20	64.73
I.M.R.F./Soc. Sec. Fund	50-2190-	CSBO SALARY IMRF	4,180.57	0.00	0.00	0.00	4,180.57	0.00	0.00
I.M.R.F./Soc. Sec. Fund	50-2190-	CSBO SALARY FICA	3,404.71	0.00	0.00	0.00	3,404.71	0.00	0.00
I.M.R.F./Soc. Sec. Fund	52190214	BUSINESS MGR MEDICARE	945.34	73.30	0.00	0.00	280.48	664.86	70.33
I.M.R.F./Soc. Sec. Fund	50-2210-	PROF. DEVELOPMENT	0.00	0.00	0.00	0.00	0.00	0.00	234 0.00
I.M.R.F./Soc. Sec. Fund	50-2210-	DIR C/I SEC. SALARY IMRF	3,568.93	286.88	0.00	0.00	1,009.46	2,559.47	71.72
I.M.R.F./Soc. Sec. Fund	50-2210-	PROF. DEVELOPMENT	0.00	0.00	0.00	0.00	0.00	0.00	0.00
I.M.R.F./Soc. Sec. Fund		50 E 2210 2130 00 300	0.00	0.00	0.00	0.00	0.00	0.00	0.00
I.M.R.F./Soc. Sec. Fund	50-2210-	DIR C/I SEC. SALARY (FR)	1,898.34	144.54	0.00	0.00	572.98	1,325.36	69.82
I.M.R.F./Soc. Sec. Fund		TITLE II MEDICARE	0.00	8.29	0.00	0.00	-64.41	64.41	0.00
I.M.R.F./Soc. Sec. Fund	50-2210-	DIRECTOR C/I SALARY	1,833.78	161.44	0.00	0.00	378.69	1,455.09	79.35
I.M.R.F./Soc. Sec. Fund		TITLE II MEDICARE	185.88	0.00	0.00	0.00	182.98	2.90	1.56
I.M.R.F./Soc. Sec. Fund		DIRECTOR C/I SEC	443.95	33.80	0.00	0.00	133.98	309.97	69.82
I.M.R.F./Soc. Sec. Fund	52212214	CURR DEVLOP/LEARN OBJ	0.00	0.00	0.00	0.00	0.00	0.00	0.00
I.M.R.F./Soc. Sec. Fund	52213212	STAFF DEVELOPMENT	0.00	0.00	0.00	0.00	0.00	0.00	0.00
I.M.R.F./Soc. Sec. Fund	52213213	STAFF DEVELOPMENT	0.00	0.00	0.00	0.00	0.00	0.00	0.00
I.M.R.F./Soc. Sec. Fund	52213214	TYPE 75 MEDICARE	0.00	0.00	0.00	0.00	0.00	0.00	0.00
I.M.R.F./Soc. Sec. Fund	52222212	LIBRARY IMRF	6,135.84	453.00	0.00	0.00	2,116.79	4,019.05	65.50

## Expenditure Report

Fiscal Year: 2023-2024  
Month: March

COUNTY OF GRUNDY SCHOOL DIST 111

Fund Description	Account	Account Description	Revised Budget	MTD Activity	Encumbrance	Pending Activity	Available Funds	Year to Date Activity	Percent of Budget Used
I.M.R.F./Soc. Sec. Fund	522222122	LIBRARY IMRF S.C.	3,130.84	232.10	0.00	0.00	1,060.85	2,069.99	66.12
I.M.R.F./Soc. Sec. Fund	52222213	LIBRARY FICA	3,996.69	305.60	0.00	0.00	1,261.61	2,735.08	68.43
I.M.R.F./Soc. Sec. Fund	522222132	LIB ASST FICA S.C.	1,880.12	144.94	0.00	0.00	573.31	1,306.81	69.51
I.M.R.F./Soc. Sec. Fund	52222214	LIBRARY MEDICARE	934.56	71.48	0.00	0.00	294.86	639.70	68.45
I.M.R.F./Soc. Sec. Fund		LIB ASST FICA	907.40	65.70	0.00	0.00	288.78	618.62	68.18
I.M.R.F./Soc. Sec. Fund	522222142	LIB ASST MEDICARE S.C.	439.69	33.90	0.00	0.00	134.01	305.68	69.52
I.M.R.F./Soc. Sec. Fund	52225212	TECH IMRF	10,104.79	784.44	0.00	0.00	3,106.26	6,998.53	69.26
I.M.R.F./Soc. Sec. Fund		NTSPEC IMRF	8,761.93	689.96	0.00	0.00	2,694.09	6,067.84	69.25
I.M.R.F./Soc. Sec. Fund	522252122	TECH IMRF S.C.	6,883.86	547.96	0.00	0.00	2,028.94	4,854.92	70.53
I.M.R.F./Soc. Sec. Fund	52225213	TECH FICA	7,221.08	513.72	0.00	0.00	2,058.36	5,162.72	71.50
I.M.R.F./Soc. Sec. Fund		NTSPEC FICA	5,506.59	446.96	0.00	0.00	1,541.56	3,965.03	23572.01
I.M.R.F./Soc. Sec. Fund	522252132	TECH ASST FICA S.C.	4,441.16	353.68	0.00	0.00	1,280.61	3,160.55	71.16
I.M.R.F./Soc. Sec. Fund	52225214	TECH/CYBRARY AIDE	1,704.04	120.14	0.00	0.00	455.03	1,249.01	73.30
I.M.R.F./Soc. Sec. Fund		TECH ASST MEDICARE	1,287.80	104.53	0.00	0.00	360.49	927.31	72.01
I.M.R.F./Soc. Sec. Fund	50-2225-	TECH ASST SALARY S.C.	1,038.77	82.72	0.00	0.00	299.54	739.23	71.16
I.M.R.F./Soc. Sec. Fund		TESTING SALARIES	26.10	0.00	0.00	0.00	26.10	0.00	0.00
I.M.R.F./Soc. Sec. Fund	50-2300-212	TEST PROCTOR IMRF	0.00	0.00	0.00	0.00	0.00	0.00	0.00
I.M.R.F./Soc. Sec. Fund	50-2300-213	TEST PROCTOR FICA	0.00	0.00	0.00	0.00	0.00	0.00	0.00
I.M.R.F./Soc. Sec. Fund	50-2300-214	TEST PROCTOR	0.00	0.00	0.00	0.00	-3.96	3.96	0.00
I.M.R.F./Soc. Sec. Fund	52310213	BOARD OF ED FICA	0.00	0.00	0.00	0.00	0.00	0.00	0.00
I.M.R.F./Soc. Sec. Fund	52310214	BOARD OF ED MEDICARE	0.00	0.00	0.00	0.00	0.00	0.00	0.00
I.M.R.F./Soc. Sec. Fund	52312212	BOARD SECY IMRF	0.00	0.00	0.00	0.00	0.00	0.00	0.00
I.M.R.F./Soc. Sec. Fund	52312213	BOARD SECY FICA	0.00	0.00	0.00	0.00	0.00	0.00	0.00
I.M.R.F./Soc. Sec. Fund	52313214	PERFORMANCE	0.00	0.00	0.00	0.00	0.00	0.00	0.00

## Expenditure Report

Fiscal Year: 2023-2024  
Month: March

COUNTY OF GRUNDY SCHOOL DIST 111

Fund Description	Account	Account Description	Revised Budget	MTD Activity	Encumbrance	Pending Activity	Available Funds	Year to Date Activity	Percent of Budget Used
I.M.R.F./Soc. Sec. Fund	52321212	SUPT SECY IMRF	5,877.80	446.08	0.00	0.00	1,819.54	4,058.26	69.04
I.M.R.F./Soc. Sec. Fund	52321213	SUPT SECY FICA	3,271.35	251.94	0.00	0.00	924.61	2,346.74	71.74
I.M.R.F./Soc. Sec. Fund	52321214	SUPT SECY MEDICARE	765.03	58.92	0.00	0.00	216.22	548.81	71.74
I.M.R.F./Soc. Sec. Fund		SUPT MEDICARE	2,905.68	233.54	0.00	0.00	789.86	2,115.82	72.82
I.M.R.F./Soc. Sec. Fund	52367212	CAMPUS MONITOR IMRF	0.00	0.00	0.00	0.00	0.00	0.00	0.00
I.M.R.F./Soc. Sec. Fund		NURSE IMRF	0.00	0.00	0.00	0.00	0.00	0.00	0.00
I.M.R.F./Soc. Sec. Fund		DEANS SECY IMRF	0.00	0.00	0.00	0.00	0.00	0.00	0.00
I.M.R.F./Soc. Sec. Fund	52367213	CAMPUS MONITOR FICA	0.00	0.00	0.00	0.00	0.00	0.00	0.00
I.M.R.F./Soc. Sec. Fund		NURSE FICE	0.00	0.00	0.00	0.00	0.00	0.00	0.00
I.M.R.F./Soc. Sec. Fund		DEANS SECY FICA	0.00	0.00	0.00	0.00	0.00	0.00	0.00
I.M.R.F./Soc. Sec. Fund	52367214	CAMPUS MONITOR	0.00	0.00	0.00	0.00	0.00	0.00	236 0.00
I.M.R.F./Soc. Sec. Fund		NURSE MEDICARE	0.00	0.00	0.00	0.00	0.00	0.00	0.00
I.M.R.F./Soc. Sec. Fund		DEANS SECY MEDICARE	0.00	0.00	0.00	0.00	0.00	0.00	0.00
I.M.R.F./Soc. Sec. Fund	52410212	PRINCIPAL SECY IMRF	4,473.96	292.17	0.00	0.00	1,929.23	2,544.73	56.88
I.M.R.F./Soc. Sec. Fund		AP SECY IMRF	6,157.54	448.72	0.00	0.00	2,144.64	4,012.90	65.17
I.M.R.F./Soc. Sec. Fund	52140213	PRINCIPAL SECY FICA	2,801.77	184.81	0.00	0.00	1,173.00	1,628.77	58.13
I.M.R.F./Soc. Sec. Fund		AP SECY FICA	3,974.11	299.58	0.00	0.00	1,270.38	2,703.73	68.03
I.M.R.F./Soc. Sec. Fund	52410214	PRINCIPAL SECY	655.26	43.22	0.00	0.00	274.35	380.91	58.13
I.M.R.F./Soc. Sec. Fund		PRINCIPAL MEDICARE	2,195.88	175.70	0.00	0.00	608.03	1,587.85	72.31
I.M.R.F./Soc. Sec. Fund		AP SECY MEDICARE	929.41	70.06	0.00	0.00	297.10	632.31	68.03
I.M.R.F./Soc. Sec. Fund		ASST PRINCIPAL	1,936.80	154.56	0.00	0.00	534.57	1,402.23	72.40
I.M.R.F./Soc. Sec. Fund		DEANS MEDICARE	5,339.59	396.22	0.00	0.00	1,780.11	3,559.48	66.66
I.M.R.F./Soc. Sec. Fund	524102142	PRINCIPAL MEDICARE S.C.	1,729.39	138.80	0.00	0.00	479.14	1,250.25	72.29
I.M.R.F./Soc. Sec. Fund	52490212	DEANS SECY IMRF	7,146.93	510.62	0.00	0.00	2,772.59	4,374.34	61.21

## Expenditure Report

Fiscal Year: 2023-2024  
Month: March

COUNTY OF GRUNDY SCHOOL DIST 111

Fund Description	Account	Account Description	Revised Budget	MTD Activity	Encumbrance	Pending Activity	Available Funds	Year to Date Activity	Percent of Budget Used
I.M.R.F./Soc. Sec. Fund	52490213	DEANS SECY FICA	4,204.52	320.02	0.00	0.00	1,405.44	2,799.08	66.57
I.M.R.F./Soc. Sec. Fund	52490214	DEANS OFFICE MEDICARE	983.28	74.82	0.00	0.00	328.81	654.47	66.56
I.M.R.F./Soc. Sec. Fund	50-2510-	CSBO SALARY IMRF	0.00	0.00	0.00	0.00	0.00	0.00	0.00
I.M.R.F./Soc. Sec. Fund	50-2510-	CSBO SALARY FICA	0.00	0.00	0.00	0.00	0.00	0.00	0.00
I.M.R.F./Soc. Sec. Fund	52510214	CSBO MEDICARE	2,765.99	146.62	0.00	0.00	1,436.00	1,329.99	48.08
I.M.R.F./Soc. Sec. Fund	52525212	BUSINESS OFFICE IMRF	18,008.64	1,119.60	0.00	0.00	7,707.13	10,301.51	57.20
I.M.R.F./Soc. Sec. Fund	52525213	BOOKKEEPER FICA	9,312.23	738.72	0.00	0.00	2,487.11	6,825.12	73.29
I.M.R.F./Soc. Sec. Fund		BOOKKEEPER MEDICARE	5,014.06	388.26	0.00	0.00	1,498.52	3,515.54	70.11
I.M.R.F./Soc. Sec. Fund	52540212	CUSTODIAN IMRF	1,680.67	128.04	0.00	0.00	94.02	1,586.65	94.41
I.M.R.F./Soc. Sec. Fund		CUSTODIAN IMRF	64,866.07	5,568.20	0.00	0.00	16,563.88	48,302.19	74.46
I.M.R.F./Soc. Sec. Fund	525402122	CUSTODIAN IMRF S.C.	0.00	0.00	0.00	0.00	0.00	0.00	237 0.00
I.M.R.F./Soc. Sec. Fund	52540213	CUSTODIAN FICA	1,299.14	86.39	0.00	0.00	218.84	1,080.30	83.16
I.M.R.F./Soc. Sec. Fund		CUSTODIAN FICA	41,870.38	3,720.29	0.00	0.00	9,056.87	32,813.51	78.37
I.M.R.F./Soc. Sec. Fund	525402132	CUSTODIAN FICA S.C.	0.00	0.00	0.00	0.00	0.00	0.00	0.00
I.M.R.F./Soc. Sec. Fund	50-2540-	CUSTODIANS SALARY	220.13	20.23	0.00	0.00	-32.74	252.87	114.87
I.M.R.F./Soc. Sec. Fund		CUSTODIANS MEDICARE	9,792.44	870.01	0.00	0.00	2,118.57	7,673.87	78.37
I.M.R.F./Soc. Sec. Fund		CUSTODIAN MEDICARE	0.00	0.00	0.00	0.00	0.00	0.00	0.00
I.M.R.F./Soc. Sec. Fund	52541212	SUMMER CUSTODIAN	230.55	0.00	0.00	0.00	-308.31	538.86	233.73
I.M.R.F./Soc. Sec. Fund	52541213	SUMMER CUSTODIAN FICA	1,213.36	0.00	0.00	0.00	-25.09	1,238.45	102.07
I.M.R.F./Soc. Sec. Fund		SUMMER CUSTODIAN	283.75	0.00	0.00	0.00	-5.87	289.62	102.07
I.M.R.F./Soc. Sec. Fund	52550212	TRANS SECY IMRF	9,579.03	745.69	0.00	0.00	3,320.40	6,258.63	65.34
I.M.R.F./Soc. Sec. Fund		BUS DRIVER IMRF	5,156.67	227.69	0.00	0.00	3,851.41	1,305.26	25.31
I.M.R.F./Soc. Sec. Fund		BUS DRIVER OOD ROUTE	60,667.33	4,366.71	0.00	0.00	21,263.10	39,404.23	64.95
I.M.R.F./Soc. Sec. Fund		BUS DRIVER REG ROUTE	56,893.10	3,412.98	0.00	0.00	26,271.79	30,621.31	53.82

## Expenditure Report

Fiscal Year: 2023-2024  
Month: March

COUNTY OF GRUNDY SCHOOL DIST 111

Fund Description	Account	Account Description	Revised Budget	MTD Activity	Encumbrance	Pending Activity	Available Funds	Year to Date Activity	Percent of Budget Used
I.M.R.F./Soc. Sec. Fund		BOOKKEEPER IMRF	724.68	0.00	0.00	0.00	689.93	34.75	4.80
I.M.R.F./Soc. Sec. Fund		BUS AID OOD IMRF	8,007.30	609.67	0.00	0.00	2,317.12	5,690.18	71.06
I.M.R.F./Soc. Sec. Fund		BUS SHUTTLES IMRF	44.61	68.91	0.00	0.00	-650.67	695.28	1,558.57
I.M.R.F./Soc. Sec. Fund		FULL TIME DRIVER IMRF	9,060.30	538.86	0.00	0.00	4,010.51	5,049.79	55.74
I.M.R.F./Soc. Sec. Fund	52550213	TRANS SECY FICA	6,410.89	486.55	0.00	0.00	2,563.55	3,847.34	60.01
I.M.R.F./Soc. Sec. Fund		BUS DRIVER FICA	3,677.27	161.34	0.00	0.00	2,691.22	986.05	26.81
I.M.R.F./Soc. Sec. Fund		BUS DRIVER OOD ROUTE	40,374.80	3,043.25	0.00	0.00	12,476.56	27,898.24	69.10
I.M.R.F./Soc. Sec. Fund		BUS DRIVER REG ROUTE	39,985.58	2,467.75	0.00	0.00	17,719.34	22,266.24	55.69
I.M.R.F./Soc. Sec. Fund		BOOKKEEPER FICA	441.28	0.00	0.00	0.00	421.71	19.57	4.43
I.M.R.F./Soc. Sec. Fund		BUS AID OOD FICA	6,920.16	447.04	0.00	0.00	2,398.39	4,521.77	65.34
I.M.R.F./Soc. Sec. Fund		BUS SHUTTLES FICE	112.66	47.79	0.00	0.00	-433.40	546.06	2384.70
I.M.R.F./Soc. Sec. Fund		FULL TIME DRIVER FICA	5,795.30	350.46	0.00	0.00	2,470.89	3,324.41	57.36
I.M.R.F./Soc. Sec. Fund		TRANS SECY MEDICARE	1,468.31	113.76	0.00	0.00	568.53	899.78	61.28
I.M.R.F./Soc. Sec. Fund		BUS DRIVER MEDICARE	860.16	37.74	0.00	0.00	629.50	230.66	26.82
I.M.R.F./Soc. Sec. Fund		BUS DRIVER OOD ROUTE	9,441.99	711.78	0.00	0.00	2,917.39	6,524.60	69.10
I.M.R.F./Soc. Sec. Fund		BUS DRIVER REG ROUTE	9,351.62	577.10	0.00	0.00	4,144.39	5,207.23	55.68
I.M.R.F./Soc. Sec. Fund		BOOKKEEPER MEDICARE	103.09	9.40	0.00	0.00	18.11	84.98	82.43
I.M.R.F./Soc. Sec. Fund		BUS AID OOD MEDICARE	1,618.50	104.57	0.00	0.00	560.85	1,057.65	65.35
I.M.R.F./Soc. Sec. Fund		BUS SHUTTLES MEDICARE	26.35	11.16	0.00	0.00	-101.29	127.64	484.40
I.M.R.F./Soc. Sec. Fund		FULL TIME DRIVER	1,355.34	81.97	0.00	0.00	577.85	777.49	57.36
I.M.R.F./Soc. Sec. Fund	52554212	BUS MECHANIC IMRF	11,246.85	525.55	0.00	0.00	5,667.11	5,579.74	49.61
I.M.R.F./Soc. Sec. Fund		TRANS DIRECTORS IMRF	8,296.21	1,175.12	0.00	0.00	740.95	7,555.26	91.07
I.M.R.F./Soc. Sec. Fund	52554213	BUS MECHANIC FICA	6,630.47	317.35	0.00	0.00	3,227.13	3,403.34	51.33
I.M.R.F./Soc. Sec. Fund		TRANS DIRECTORS FICA	6,950.27	783.32	0.00	0.00	1,900.20	5,050.07	72.66

## Expenditure Report

Fiscal Year: 2023-2024  
Month: March

COUNTY OF GRUNDY SCHOOL DIST 111

Fund Description	Account	Account Description	Revised Budget	MTD Activity	Encumbrance	Pending Activity	Available Funds	Year to Date Activity	Percent of Budget Used
I.M.R.F./Soc. Sec. Fund		BUS MECHANIC MEDICARE	1,520.38	74.22	0.00	0.00	724.43	795.95	52.35
I.M.R.F./Soc. Sec. Fund		TRANS DIRECTORS	1,386.61	183.21	0.00	0.00	205.53	1,181.08	85.18
I.M.R.F./Soc. Sec. Fund	52632212	DEAN SEC IMRF	3,128.63	228.28	0.00	0.00	1,044.82	2,083.81	66.60
I.M.R.F./Soc. Sec. Fund	52632213	DEAN SECY FICA	1,796.10	129.50	0.00	0.00	552.37	1,243.73	69.25
I.M.R.F./Soc. Sec. Fund	52632214	DEAN SECY MEDICARE	420.29	30.30	0.00	0.00	129.32	290.97	69.23
I.M.R.F./Soc. Sec. Fund	52633212	PUBLIC INFO IMRF	8,163.00	689.26	0.00	0.00	2,013.68	6,149.32	75.33
I.M.R.F./Soc. Sec. Fund	52633213	PUBLIC INFO FICA	5,580.00	465.00	0.00	0.00	1,392.34	4,187.66	75.05
I.M.R.F./Soc. Sec. Fund		PUBLIC INFO MEDICARE	1,305.00	108.76	0.00	0.00	325.56	979.44	75.05
I.M.R.F./Soc. Sec. Fund	53200212	WELLNESS CENTER IMRF	0.00	0.00	0.00	0.00	0.00	0.00	0.00
I.M.R.F./Soc. Sec. Fund	53200213	WELLNESS CENTER	0.00	0.00	0.00	0.00	0.00	0.00	0.00
I.M.R.F./Soc. Sec. Fund	532002131	WELLNESS CENTER	0.00	0.00	0.00	0.00	0.00	0.00	239 0.00
I.M.R.F./Soc. Sec. Fund	53200214	WELLNESS CENTER	0.00	0.00	0.00	0.00	0.00	0.00	0.00
I.M.R.F./Soc. Sec. Fund	50-4100-	TITLE I SALARY (RM)	0.00	0.00	0.00	0.00	0.00	0.00	0.00
I.M.R.F./Soc. Sec. Fund	50-4100-	TITLE I SALARY (FR)	0.00	0.00	0.00	0.00	0.00	0.00	0.00
I.M.R.F./Soc. Sec. Fund	54120214	SPEC ED HB MEDICARE	0.00	0.00	0.00	0.00	0.00	0.00	0.00
I.M.R.F./Soc. Sec. Fund	50-481-212-	IMRF (RM)	0.00	0.00	0.00	0.00	0.00	0.00	0.00
I.M.R.F./Soc. Sec. Fund	50-481-212-	IMRF (RM)	0.00	0.00	0.00	0.00	0.00	0.00	0.00
I.M.R.F./Soc. Sec. Fund	50-481-213-	IMRF (FR)	0.00	0.00	0.00	0.00	0.00	0.00	0.00
I.M.R.F./Soc. Sec. Fund	50-481-213-	IMRF (FR)	0.00	0.00	0.00	0.00	0.00	0.00	0.00
I.M.R.F./Soc. Sec. Fund		ESSER IMRF	60.98	0.00	0.00	0.00	0.00	60.98	100.00
I.M.R.F./Soc. Sec. Fund		ESSER FICA	41.69	0.00	0.00	0.00	0.00	41.69	100.00
I.M.R.F./Soc. Sec. Fund		ESSER MEDICARE	19.20	0.00	0.00	0.00	9.45	9.75	50.78
I.M.R.F./Soc. Sec. Fund		UNFUNDED LIABILITY	200,000.00	0.00	0.00	0.00	200,000.00	0.00	0.00
<b>50 - -----</b>			<b>1,273,420.27</b>	<b>80,896.75</b>	<b>0.00</b>	<b>0.00</b>	<b>548,047.61</b>	<b>725,372.66</b>	

## Expenditure Report

Fiscal Year: 2023-2024  
Month: March

COUNTY OF GRUNDY SCHOOL DIST 111

Fund Description	Account	Account Description	Revised Budget	MTD Activity	Encumbrance	Pending Activity	Available Funds	Year to Date Activity	Percent of Budget Used
<b>5- - - - -</b>			<b>1,273,420.27</b>	<b>80,896.75</b>	<b>0.00</b>	<b>0.00</b>	<b>548,047.61</b>	<b>725,372.66</b>	
Capital Projects Fund or	62530500	FAC ACQ & CONSTR SERV	19.20	0.00	0.00	0.00	19.20	0.00	0.00
Capital Projects Fund or	62530501	FAC ACQ & CONSTR SERV	0.00	0.00	0.00	0.00	0.00	0.00	0.00
Capital Projects Fund or	62532390	REIMB EXPENSES	0.00	0.00	0.00	0.00	0.00	0.00	0.00
Capital Projects Fund or	62532520	BULDING PURCHASE LAND	0.00	0.00	0.00	0.00	0.00	0.00	0.00
Capital Projects Fund or	62532530	SIGNALIZATION	0.00	0.00	0.00	0.00	0.00	0.00	0.00
Capital Projects Fund or	62533316	A & E FEES	650,000.00	78,738.51	0.00	0.00	45,037.91	604,962.09	93.07
Capital Projects Fund or	62533314	TCC CONST FEES	0.00	0.00	0.00	0.00	0.00	0.00	0.00
Capital Projects Fund or	62533310	A & E FEES/PROJECT 2279	0.00	0.00	0.00	0.00	0.00	0.00	0.00
Capital Projects Fund or	62533311	A & E FEES/PROJECT 2299	0.00	0.00	0.00	0.00	0.00	0.00	0.00
Capital Projects Fund or	62533312	A & E FEES/PROJECT 2386	0.00	0.00	0.00	0.00	0.00	0.00	240 0.00
Capital Projects Fund or	62533313	A & E FEES/PROJECT 6003	0.00	0.00	0.00	0.00	0.00	0.00	0.00
Capital Projects Fund or	62533315	A & E FEES/2009	0.00	0.00	0.00	0.00	0.00	0.00	0.00
Capital Projects Fund or	62533320	A & E FEES/PROJECT	0.00	0.00	0.00	0.00	0.00	0.00	0.00
Capital Projects Fund or	62533318	LEGAL SERVICES	0.00	0.00	0.00	0.00	0.00	0.00	0.00
Capital Projects Fund or	62533319	PROF TECH SERV	0.00	0.00	0.00	0.00	0.00	0.00	0.00
Capital Projects Fund or	62533390	OTHER PUR SERV-STRC	0.00	0.00	0.00	0.00	0.00	0.00	0.00
Capital Projects Fund or	62533391	OTHER PUR SERV-STRC	0.00	0.00	0.00	0.00	0.00	0.00	0.00
Capital Projects Fund or	62535315	BLDRS RISK COVERAGE	0.00	0.00	0.00	0.00	0.00	0.00	0.00
Capital Projects Fund or	62535325	CAPITAL IMPROVEMENT	8,500,000.00	667,452.59	1,097,396.20	0.00	3,378,850.75	4,023,753.05	47.34
Capital Projects Fund or	62535323	BLEACHER REPAIR &	0.00	0.00	0.00	0.00	0.00	0.00	0.00
Capital Projects Fund or	62535324	CENTRAL PAC	0.00	0.00	0.00	0.00	0.00	0.00	0.00
Capital Projects Fund or	62535523	BLEACHER CAPITAL	0.00	0.00	0.00	0.00	0.00	0.00	0.00
Capital Projects Fund or	62535525	CAPITAL IMPROVEMENTS	2,000,000.00	94,807.05	12,294.00	0.00	1,331,427.57	656,278.43	32.81

## Expenditure Report

Fiscal Year: 2023-2024  
Month: March

COUNTY OF GRUNDY SCHOOL DIST 111

Fund Description	Account	Account Description	Revised Budget	MTD Activity	Encumbrance	Pending Activity	Available Funds	Year to Date Activity	Percent of Budget Used
Capital Projects Fund or	62535554	CONTINGENCY COSTS	0.00	0.00	0.00	0.00	0.00	0.00	0.00
Capital Projects Fund or	62535555	CONSTR COSTS #6003	0.00	0.00	0.00	0.00	0.00	0.00	0.00
Capital Projects Fund or		ESSER III CAPITAL	0.00	0.00	0.00	0.00	0.00	0.00	0.00
Capital Projects Fund or	62535559	CONSTRUCTION COST	0.00	0.00	0.00	0.00	0.00	0.00	0.00
Capital Projects Fund or	62535558	TRANSPORTATION COST	0.00	0.00	0.00	0.00	0.00	0.00	0.00
Capital Projects Fund or	62535558	CONSTRUCTION COST	0.00	0.00	0.00	0.00	0.00	0.00	0.00
Capital Projects Fund or	62535550	CONSTR COSTS #2279	0.00	0.00	0.00	0.00	0.00	0.00	0.00
Capital Projects Fund or	62535551	CONSTR COSTS #2299	0.00	0.00	0.00	0.00	0.00	0.00	0.00
Capital Projects Fund or	62535552	CONTINGENCY COSTS	0.00	0.00	0.00	0.00	0.00	0.00	0.00
Capital Projects Fund or	62535553	CONTINGENCY COSTS	0.00	0.00	0.00	0.00	0.00	0.00	0.00
Capital Projects Fund or	62535556	FF & E COSTS #6003	0.00	0.00	0.00	0.00	0.00	0.00	241.00
Capital Projects Fund or	62535557	CONSTR COSTS/2009	0.00	0.00	0.00	0.00	0.00	0.00	0.00
Capital Projects Fund or	68140	TRANS OF INTEREST	0.00	0.00	0.00	0.00	0.00	0.00	0.00
Capital Projects Fund or	68180611	PERM TRANS FROM W/C	0.00	0.00	0.00	0.00	0.00	0.00	0.00
<b>60 - -----</b>			<b>11,150,019.20</b>	<b>840,998.15</b>	<b>1,109,690.20</b>	<b>0.00</b>	<b>4,755,335.43</b>	<b>5,284,993.57</b>	
<b>6- - -----</b>			<b>11,150,019.20</b>	<b>840,998.15</b>	<b>1,109,690.20</b>	<b>0.00</b>	<b>4,755,335.43</b>	<b>5,284,993.57</b>	
Working Cash Fund	78180611	PERM TRANS FROM W/C	0.00	0.00	0.00	0.00	0.00	0.00	0.00
Working Cash Fund	78180710	PERM TRANS OF W/C-	0.00	0.00	0.00	0.00	0.00	0.00	0.00
Working Cash Fund	78990	OTHER USES NOT	0.00	0.00	0.00	0.00	0.00	0.00	0.00
<b>70 - -----</b>			<b>0.00</b>	<b>0.00</b>	<b>0.00</b>	<b>0.00</b>	<b>0.00</b>	<b>0.00</b>	
<b>7- - -----</b>			<b>0.00</b>	<b>0.00</b>	<b>0.00</b>	<b>0.00</b>	<b>0.00</b>	<b>0.00</b>	
Tort Immunity and	81130100	CAMPUS MONITOR	246,046.56	22,358.67	0.00	0.00	65,146.13	180,900.43	73.52
Tort Immunity and	81130101	NURSE SALARY	3,073.92	457.40	0.00	0.00	-14.73	3,088.65	100.48
Tort Immunity and	81130102	DEANS SALARY	73,514.16	5,279.52	0.00	0.00	26,761.20	46,752.96	63.60

## Expenditure Report

Fiscal Year: 2023-2024  
Month: March

COUNTY OF GRUNDY SCHOOL DIST 111

Fund Description	Account	Account Description	Revised Budget	MTD Activity	Encumbrance	Pending Activity	Available Funds	Year to Date Activity	Percent of Budget Used
Tort Immunity and		DEANS TRS	9,007.50	500.00	0.00	0.00	4,494.07	4,513.43	50.11
Tort Immunity and		DIST 111 GROUP MEDICAL	104,396.57	6,076.03	0.00	0.00	46,369.08	58,027.49	55.58
Tort Immunity and		CAMPUS MONITOR	104,582.93	14,697.22	0.00	0.00	3,860.77	100,722.16	96.31
Tort Immunity and		NURSE MEDICAL INS	4.20	0.20	0.00	0.00	1.49	2.71	64.52
Tort Immunity and		DEANS MEDICAL INS	24,773.06	1,632.08	0.00	0.00	11,141.27	13,631.79	55.03
Tort Immunity and		DIST 111 GROUP DENTAL	5,664.70	34.98	0.00	0.00	3,002.26	2,662.44	47.00
Tort Immunity and		DEANS DENTAL INS	381.08	30.86	0.00	0.00	135.09	245.99	64.55
Tort Immunity and	82310200	BOARD OF ED-OTHER	0.00	0.00	0.00	0.00	0.00	0.00	0.00
Tort Immunity and	82310318	ATTORNEY FEES	70,000.00	734.50	0.00	0.00	38,073.80	31,926.20	45.61
Tort Immunity and	82362381	WORK COMP PREMIUMS	230,000.00	19,518.00	0.00	0.00	44,393.00	185,607.00	80.70
Tort Immunity and	82363380	UNEMPLOYMENT INS	0.00	0.00	0.00	0.00	0.00	0.00	242 0.00
Tort Immunity and	82364382	PROPERTY INLAND	0.00	0.00	0.00	0.00	0.00	0.00	0.00
Tort Immunity and	82364383	GEN LIABILITY INS	275,000.00	0.00	0.00	0.00	-9,688.89	284,688.89	103.52
Tort Immunity and	82364384	SLEO/SMM	0.00	0.00	0.00	0.00	0.00	0.00	0.00
Tort Immunity and	82364385	UMBRELLA	24,000.00	0.00	0.00	0.00	584.86	23,415.14	97.56
Tort Immunity and	82364386	STUDENT CATASTROPHIC	3,200.00	0.00	0.00	0.00	-1,093.50	4,293.50	134.17
Tort Immunity and	82365395	SAFETY/INSURANCE	15,000.00	0.00	0.00	0.00	-17,795.00	32,795.00	218.63
Tort Immunity and	82365390	EVENT SECURITY POLICE	50,000.00	5,986.70	0.00	0.00	9,919.29	40,080.71	80.16
Tort Immunity and	82365391	SRO	65,000.00	11,526.09	0.00	0.00	16,109.41	48,890.59	75.22
Tort Immunity and	82365393	BUILD REPAIR MAINT/FIRE	20,000.00	1,871.31	0.00	0.00	-823.93	20,823.93	104.12
Tort Immunity and	82365394	BUILD REPAIR/COMM	0.00	0.00	0.00	0.00	0.00	0.00	0.00
Tort Immunity and	823653922	SRO - S.C.	75,000.00	8,940.87	0.00	0.00	21,354.78	53,645.22	71.53
Tort Immunity and		BUILD REPAIR MAINT/FIRE	15,000.00	0.00	0.00	0.00	15,000.00	0.00	0.00
Tort Immunity and		BUILD REPAIR/MAINT FIRE	5,000.00	0.00	0.00	0.00	4,850.00	150.00	3.00

## Expenditure Report

Fiscal Year: 2023-2024  
Month: March

COUNTY OF GRUNDY SCHOOL DIST 111

Fund Description	Account	Account Description	Revised Budget	MTD Activity	Encumbrance	Pending Activity	Available Funds	Year to Date Activity	Percent of Budget Used
Tort Immunity and	82367110	CAMPUS MONITOR SUB	0.00	0.00	0.00	0.00	0.00	0.00	0.00
Tort Immunity and	82367130	CAMPUS MON. EXTRA	0.00	0.00	0.00	0.00	0.00	0.00	0.00
Tort Immunity and	82367211	DEANS TRS	0.00	0.00	0.00	0.00	0.00	0.00	0.00
Tort Immunity and		DEANS TRS	0.00	0.00	0.00	0.00	0.00	0.00	0.00
Tort Immunity and	80-2367-	DEANS SALARY (BCE-P)	0.00	0.00	0.00	0.00	0.00	0.00	0.00
Tort Immunity and		NURSE GROUP INS	0.00	0.00	0.00	0.00	0.00	0.00	0.00
Tort Immunity and		DEANS INS	0.00	0.00	0.00	0.00	0.00	0.00	0.00
Tort Immunity and		DEANS DENTAL	0.00	0.00	0.00	0.00	0.00	0.00	0.00
Tort Immunity and	82542301	BUILDING SECURITY	25,000.00	2,000.00	0.00	0.00	1,117.39	23,882.61	95.53
Tort Immunity and	82542320	BUILDING INSPECTIONS	0.00	0.00	0.00	0.00	0.00	0.00	0.00
Tort Immunity and	82546410	SECURITY SUPPLIES	50,000.00	0.00	60,214.40	0.00	-10,214.40	0.00	243 0.00
Tort Immunity and	825464102	SECURITY SUPPLIES	0.00	0.00	0.00	0.00	0.00	0.00	0.00
Tort Immunity and	82546540	SECURITY EQUIPMENT	40,000.00	0.00	71,359.38	0.00	-38,599.38	7,240.00	18.10
Tort Immunity and	825465402	SECURITY EQUIPMENT	40,000.00	0.00	0.00	0.00	40,000.00	0.00	0.00
Tort Immunity and		Interfund Transfer	0.00	0.00	0.00	0.00	0.00	0.00	0.00
Tort Immunity and		TRANSFER AMONG FUNDS	0.00	0.00	0.00	0.00	0.00	0.00	0.00
<b>80 - -----</b>			<b>1,573,644.68</b>	<b>101,644.43</b>	<b>131,573.78</b>	<b>0.00</b>	<b>274,084.06</b>	<b>1,167,986.84</b>	
<b>8- - -----</b>			<b>1,573,644.68</b>	<b>101,644.43</b>	<b>131,573.78</b>	<b>0.00</b>	<b>274,084.06</b>	<b>1,167,986.84</b>	
Fire Prevention & Safety	92542310	LIFE SAFETY A & E	0.00	0.00	0.00	0.00	0.00	0.00	0.00
Fire Prevention & Safety	92542311	SAFETY CONSULTATION	0.00	0.00	0.00	0.00	0.00	0.00	0.00
Fire Prevention & Safety	92542312	GAVC PROJECT	0.00	0.00	0.00	0.00	0.00	0.00	0.00
Fire Prevention & Safety	92542530	LIFE SAFETY REPAIRS	1,000,000.00	0.00	0.00	0.00	1,000,000.00	0.00	0.00

## Expenditure Report

Fiscal Year: 2023-2024  
 Month: March

COUNTY OF GRUNDY SCHOOL DIST 111

Fund Description	Account	Account Description	Revised Budget	MTD Activity	Encumbrance	Pending Activity	Available Funds	Year to Date Activity	Percent of Budget Used
Fire Prevention & Safety	92542531	LIFE SAFETY - ROOFING	0.00	0.00	0.00	0.00	0.00	0.00	0.00
<b>90 - -----</b>			<b>1,000,000.00</b>	<b>0.00</b>	<b>0.00</b>	<b>0.00</b>	<b>1,000,000.00</b>	<b>0.00</b>	
<b>9- - -----</b>			<b>1,000,000.00</b>	<b>0.00</b>	<b>0.00</b>	<b>0.00</b>	<b>1,000,000.00</b>	<b>0.00</b>	
<b>Account Monthly Activity Grand Totals:</b>			<b>79,359,073.83</b>	<b>4,804,746.26</b>	<b>2,005,919.72</b>	<b>149,228.05</b>	<b>25,742,746.93</b>	<b>51,461,179.13</b>	



# Revenue Report

Fiscal Year: 2023-2024  
Month: March

COUNTY OF GRUNDY SCHOOL DIST 111

Fund Description	Account Number	Account Description	Revised Budget	Monthly Activity	Pending Activity	Available Funds	Year to Date Activity	Percent of Budget Used
Education Fund	10 R 1110 0000 00 000 000000	PRIOR YEAR TAXES	0.00	0.00		0.00	0.00	0.00
Education Fund	10 R 1111 0000 00 000 000000	GRUNDY CO TAXES	8,123,979.00	0.00	0.00	-22,583.76	8,146,562.76	100.28
Education Fund	10 R 1112 0000 00 000 000000	KENDALL CO TAXES	1,164,829.00	0.00	0.00	-10,332.79	1,175,161.79	100.89
Education Fund	10 R 1113 0000 00 000 000000	WILL CO TAXES	6,005,651.00	0.00	0.00	303,938.66	5,701,712.34	94.94
Education Fund	10 R 1114 0000 00 000 000000	GRUNDY CO EDPA SURPLUS	560,000.00	0.00	0.00	-61,213.25	621,213.25	110.93
Education Fund	10 R 1122 0000 00 000 000000	KENDALL CO - EARLY DISTR	1,737,915.60	0.00		1,737,915.60	0.00	0.00
Education Fund	10 R 1123 0000 00 000 000000	WILL CO - EARLY DISTR	6,038,082.81	0.00		6,038,082.81	0.00	0.00
Education Fund	10 R 1210 0000 00 000 000000	MOBILE HOME TAX	0.00	0.00		0.00	0.00	0.00
Education Fund	10 R 1211 0000 00 000 000000	MOBILE HOME TAX SPECIAL ED	0.00	0.00		0.00	0.00	0.00
Education Fund	10 R 1211 0000 00 000 000001	GRUNDY CO TORT	0.00	0.00		0.00	0.00	0.00
Education Fund	10 R 1212 0000 00 000 000000	MOBILE HOME TAX - LEASE	0.00	0.00		0.00	0.00	0.00
Education Fund	10 R 1212 0000 00 000 000001	KENDALL CO TORT	0.00	0.00		0.00	0.00	246 0.00
Education Fund	10 R 1213 0000 00 000 000000	WILL CO TORT	0.00	0.00		0.00	0.00	0.00
Education Fund	10 R 1222 0000 00 000 000000	KENDALL CO TORT-EARLY DISTR	0.00	0.00		0.00	0.00	0.00
Education Fund	10 R 1223 0000 00 000 000000	WILL CO TORT-EARLY DISTR	0.00	0.00		0.00	0.00	0.00
Education Fund	10 R 1230 0000 00 000 000000	CPPRT	871,379.00	64,746.17	0.00	263,062.40	608,316.60	69.81
Education Fund	10 R 1290 0000 00 000 000000	PAYMENTS IN LIEU OF TAXES	0.00	0.00		0.00	0.00	0.00
Education Fund	10 R 1291 0000 00 000 000000	LAG FEES	0.00	0.00		0.00	0.00	0.00
Education Fund	10 R 1292 0000 00 000 000000	PAYMENT IN LIEU OF TAXES SP ED	0.00	0.00		0.00	0.00	0.00
Education Fund	10 R 1293 0000 00 000 000000	PAYMENT IN LIEU OF TAXES LEASE	0.00	0.00		0.00	0.00	0.00
Education Fund	10 R 1311 0000 00 000 000000	NON-RESIDENT TUITION	0.00	0.00		0.00	0.00	0.00
Education Fund	10 R 1311 0000 00 000 000001	GRUNDY CO LEASE	187,045.00	0.00	0.00	-8,275.82	195,320.82	104.42
Education Fund	10 R 1312 0000 00 000 000000	KENDALL CO LEASE	28,010.00	0.00	0.00	-254.49	28,264.49	100.91
Education Fund	10 R 1313 0000 00 000 000000	WILL CO LEASE	141,843.00	0.00	0.00	5,375.79	136,467.21	96.21
Education Fund	10 R 1314 0000 00 000 000000	GRUNDY CO LEASE EDPA SURPLUS	0.00	0.00		0.00	0.00	0.00
Education Fund	10 R 1321 0000 00 000 000000	TOTAL SUMMER SCHOOL TUITION	0.00	0.00		0.00	0.00	0.00

# Revenue Report

Fiscal Year: 2023-2024  
Month: March

COUNTY OF GRUNDY SCHOOL DIST 111

Fund Description	Account Number	Account Description	Revised Budget	Monthly Activity	Pending Activity	Available Funds	Year to Date Activity	Percent of Budget Used
Education Fund	10 R 1322 0000 00 000 000000	KENDALL CO LEASE-EARLY DISTR	41,798.53	0.00		41,798.53	0.00	0.00
Education Fund	10 R 1323 0000 00 000 000000	WILL CO LEASE-EARLY DISTR	144,518.05	0.00		144,518.05	0.00	0.00
Education Fund	10 R 1411 0000 00 000 000000	GRUNDY CO SPEC ED	133,178.00	0.00	0.00	-379.05	133,557.05	100.28
Education Fund	10 R 1411 0000 00 000 000001	GRUNDY CO SPEC ED TIF	0.00	0.00		0.00	0.00	0.00
Education Fund	10 R 1412 0000 00 000 000000	KENDALL CO SPEC ED	19,096.00	0.00	0.00	-168.96	19,264.96	100.88
Education Fund	10 R 1413 0000 00 000 000000	WILL CO SPEC ED	98,453.00	0.00	0.00	4,982.29	93,470.71	94.94
Education Fund	10 R 1414 0000 00 000 000000	GRUNDY CO SPEC ED EDPA SURPLUS	0.00	0.00		0.00	0.00	0.00
Education Fund	10 R 1422 0000 00 000 000000	KENDALL CO SPEC ED-EARLY DISTR	28,490.19	0.00		28,490.19	0.00	0.00
Education Fund	10 R 1423 0000 00 000 000000	WILL CO SPEC ED-EARLY DISTR	98,984.95	0.00		98,984.95	0.00	0.00
Education Fund	10 R 1510 0000 00 000 000000	CHECKING INTEREST	0.00	0.00		0.00	0.00	0.00
Education Fund	10 R 1511 0000 00 000 000000	INVESTMENT INTEREST	825,000.00	101,769.12	0.00	64,681.50	760,318.50	92.16
Education Fund	10 R 1611 0000 00 000 000000	CAFETERIA SALES CASH	250,000.00	17,994.75	0.00	68,942.74	181,057.26	72.42
Education Fund	10 R 1612 0000 00 000 000000	CAFETERIA SALES CREDIT CARD	1,135,000.00	110,690.62	0.00	250,340.39	884,659.61	77.94
Education Fund	10 R 1620 0000 00 000 000000	COFFEE SALES	0.00	0.00		0.00	0.00	0.00
Education Fund	10 R 1709 0000 00 000 000000	POST SEASON GATE RECEIPTS	15,000.00	0.00	0.00	-3,664.56	18,664.56	124.43
Education Fund	10 R 1710 0000 00 000 000000	ATHLETIC ENTRY FEES RECD	25,000.00	2,050.00	0.00	-8,974.05	33,974.05	135.90
Education Fund	10 R 1711 0000 00 000 000000	SOCCER ADMISSIONS	0.00	0.00	0.00	-6,136.00	6,136.00	0.00
Education Fund	10 R 1712 0000 00 000 000000	FOOTBALL ADMISSIONS	28,000.00	0.00	0.00	15,619.00	12,381.00	44.22
Education Fund	10 R 1713 0000 00 000 000000	XC ADMISSIONS	0.00	0.00		0.00	0.00	0.00
Education Fund	10 R 1714 0000 00 000 000000	WRESTLING ADMISSIONS	2,400.00	0.00	0.00	-1,489.00	3,889.00	162.04
Education Fund	10 R 1715 0000 00 000 000000	BOYS BASKETBALL ADMISSIONS	4,500.00	0.00	0.00	226.00	4,274.00	94.98
Education Fund	10 R 1716 0000 00 000 000000	GIRLS BSKTBLL ADMISSIONS	3,000.00	0.00	0.00	420.00	2,580.00	86.00
Education Fund	10 R 1717 0000 00 000 000000	VOLLEYBALL ADMISSIONS	4,500.00	0.00	0.00	340.00	4,160.00	92.44
Education Fund	10 R 1718 0000 00 000 000000	SPORT PASSES	10,075.00	0.00	0.00	-7,950.00	18,025.00	178.91
Education Fund	10 R 1719 0000 00 000 000000	TRACK ADMISSIONS	0.00	0.00		0.00	0.00	0.00
Education Fund	10 R 1720 0000 00 000 000000	DRIVER EDUC FEES	51,000.00	2,710.00	0.00	5,480.53	45,519.47	89.25

247

# Revenue Report

Fiscal Year: 2023-2024  
Month: March

COUNTY OF GRUNDY SCHOOL DIST 111

Fund Description	Account Number	Account Description	Revised Budget	Monthly Activity	Pending Activity	Available Funds	Year to Date Activity	Percent of Budget Used
Education Fund	10 R 1721 0000 00 000 000000	LOCK FEES	3,000.00	0.00	0.00	-480.30	3,480.30	116.01
Education Fund	10 R 1722 0000 00 000 000000	MISCELLANEOUS FEES	50,000.00	1,510.63	0.00	42,118.98	7,881.02	15.76
Education Fund	10 R 1723 0000 00 000 000000	P.E. UNIFORMS	0.00	0.00		0.00	0.00	0.00
Education Fund	10 R 1724 0000 00 000 000000	STUDENT PARKING FEES	110,000.00	1,170.00	0.00	-22,513.71	132,513.71	120.47
Education Fund	10 R 1725 0000 00 000 000000	BOWLING ADMISSIONS	0.00	0.00		0.00	0.00	0.00
Education Fund	10 R 1726 0000 00 000 000000	SPRING MUSICAL ADMISSIONS	18,000.00	0.00		18,000.00	0.00	0.00
Education Fund	10 R 1727 0000 00 000 000000	FALL PLAY ADMISSIONS	4,500.00	0.00	0.00	-243.00	4,743.00	105.40
Education Fund	10 R 1728 0000 00 000 000000	STUDENT PURCHASES	0.00	0.00		0.00	0.00	0.00
Education Fund	10 R 1729 0000 00 000 000000	INVITE ADMISSIONS	0.00	0.00	0.00	-4,506.00	4,506.00	0.00
Education Fund	10 R 1730 0000 00 000 000000	MADRIGALS ADMISSIONS	6,500.00	0.00	0.00	-1,930.00	8,430.00	129.69
Education Fund	10 R 1731 0000 00 000 000000	ACTIVITY MISC	0.00	0.00		0.00	0.00	0.00
Education Fund	10 R 1732 0000 00 000 000000	SPORT PASSES	0.00	0.00		0.00	0.00	0.00
Education Fund	10 R 1733 0000 00 000 000000	LACROSSE ADMISSIONS	0.00	0.00		0.00	0.00	248 0.00
Education Fund	10 R 1734 0000 00 000 000000	GIRLS WRESTLING ADMISSIONS	0.00	0.00		0.00	0.00	0.00
Education Fund	10 R 1790 0000 00 000 000000	OTHER PUPIL ACT REVENUE	0.00	0.00		0.00	0.00	0.00
Education Fund	10 R 1811 0000 00 000 000000	TEXTBOOK FEES	950,000.00	33,230.45	0.00	109,748.31	840,251.69	88.45
Education Fund	10 R 1825 0000 00 000 000000	AP TESTING FEE	0.00	0.00		0.00	0.00	0.00
Education Fund	10 R 1826 0000 00 000 000000	SAT TESTING FEES	6,000.00	0.00		6,000.00	0.00	0.00
Education Fund	10 R 1827 0000 00 000 000000	SALE OF EQUIPMENT	2,000.00	0.00		2,000.00	0.00	0.00
Education Fund	10 R 1828 0000 00 000 000000	A/P TEST FEES	105,000.00	462.50	0.00	-1,179.50	106,179.50	101.12
Education Fund	10 R 1829 0000 00 000 000000	MATH RESALE REVENUE	0.00	0.00		0.00	0.00	0.00
Education Fund	10 R 1920 0000 00 000 000000	IMTT GRANT	0.00	0.00		0.00	0.00	0.00
Education Fund	10 R 1950 0000 00 000 000000	REFUND OF PRIOR YR EXPENSES	75,000.00	0.00	0.00	-190,361.41	265,361.41	353.82
Education Fund	10 R 1960 0000 00 000 000000	GRUNDY COUNTY EDUCATION TIF	2,000,000.00	0.00	0.00	-7,403.60	2,007,403.60	100.37
Education Fund	10 R 1962 0000 00 000 000000	GRUNDY CO LEASE TIF	0.00	0.00	0.00	0.00	0.00	0.00
Education Fund	10 R 1963 0000 00 000 000000	GRUNDY CO SPEC ED TIF	0.00	0.00	0.00	0.00	0.00	0.00
Education Fund	10 R 1964 0000 00 000 000000	I55 & RT 6 TIF	700.00	0.00	0.00	121.06	578.94	82.71

# Revenue Report

Fiscal Year: 2023-2024  
Month: March

COUNTY OF GRUNDY SCHOOL DIST 111

Fund Description	Account Number	Account Description	Revised Budget	Monthly Activity	Pending Activity	Available Funds	Year to Date Activity	Percent of Budget Used
Education Fund	10 R 1971 0000 00 000 000000	SUMMER DR ED FEES	31,850.00	3,450.00	0.00	-3,550.00	35,400.00	111.15
Education Fund	10 R 1993 0000 00 000 000000	DISTRICT SCOREBOARD ADVERTISING	14,500.00	0.00	0.00	7,000.00	7,500.00	51.72
Education Fund	10 R 1998 0000 00 000 000000	EDUCATION FOUNDATION GRANTS	10,000.00	0.00		10,000.00	0.00	0.00
Education Fund	10 R 1999 0000 00 000 000000	OTHER-LOCAL SOURCES	50,000.00	0.00	0.00	-208,247.35	258,247.35	516.49
Education Fund	10 R 1999 2220 00 000 000000	DIST 111 GROUP MEDICAL REVENUE	4,657,108.34	424,383.72	0.00	1,074,201.85	3,582,906.49	76.93
Education Fund	10 R 1999 2230 00 000 000000	DIST 111 GROUP DENTAL REVENUE	205,918.10	17,046.37	0.00	60,383.99	145,534.11	70.68
Education Fund	10 R 2100 0000 00 000 000000	ECO LAB GRANT	0.00	0.00		0.00	0.00	0.00
Education Fund	10 R 2905 0000 00 000 000000	TRYON ST TIF	0.00	0.00	0.00	-1,441.60	1,441.60	0.00
Education Fund	10 R 3001 0000 00 000 000000	EVIDENCE BASED FUNDING	7,582,854.00	709,116.83	0.00	2,048,287.17	5,534,566.83	72.99
Education Fund	10 R 3002 0000 00 000 000000	GSA HOLD HARMLESS	0.00	0.00		0.00	0.00	0.00
Education Fund	10 R 3030 0000 00 000 000000	FAST GROWTH GRANTS	0.00	0.00		0.00	0.00	0.00
Education Fund	10 R 3099 0000 00 000 000000	TRANSITION ASSISTANCE	0.00	0.00		0.00	0.00	0.00
Education Fund	10 R 3100 0000 00 000 000000	SPEC ED-PRIVATE FACILITY	900,000.00	0.00	0.00	220,980.99	679,019.01	75.45
Education Fund	10 R 3105 0000 00 000 000000	SPEC ED- EXTRAORDINARY	0.00	0.00		0.00	0.00	0.00
Education Fund	10 R 3110 0000 00 000 000000	SPEC ED- PERSONNEL	0.00	0.00		0.00	0.00	0.00
Education Fund	10 R 3120 0000 00 000 000000	SPEC ED- ORPHANAGE/INDIV	8,000.00	0.00	0.00	3,827.88	4,172.12	52.15
Education Fund	10 R 3130 0000 00 000 000000	SP ED ORPHANAGE SUMMER IND	0.00	0.00		0.00	0.00	0.00
Education Fund	10 R 3145 0000 00 000 000000	SPEC ED- SUMMER SCHOOL	0.00	0.00		0.00	0.00	0.00
Education Fund	10 R 3215 0000 00 000 000000	VOC ED-FORMULA	0.00	0.00		0.00	0.00	0.00
Education Fund	10 R 3220 0000 00 000 000000	CAREER/TECH EDUC IMPR GRNT	72,000.00	0.00	0.00	-24,146.00	96,146.00	133.54
Education Fund	10 R 3225 0000 00 000 000000	VOC ED FORMULA REIMB.	0.00	0.00		0.00	0.00	0.00
Education Fund	10 R 3226 0000 00 000 000000	VOC ED PROGRAM IMPROVMT.	0.00	0.00		0.00	0.00	0.00
Education Fund	10 R 3235 0000 00 000 000000	VOC ED AG EDUC INCENTIVE	0.00	0.00	0.00	0.00	0.00	0.00
Education Fund	10 R 3305 0000 00 000 000000	BILINGUAL ED-DOWNSTATE	0.00	0.00		0.00	0.00	0.00

249

# Revenue Report

Fiscal Year: 2023-2024  
Month: March

COUNTY OF GRUNDY SCHOOL DIST 111

Fund Description	Account Number	Account Description	Revised Budget	Monthly Activity	Pending Activity	Available Funds	Year to Date Activity	Percent of Budget Used
Education Fund	10 R 3350 0000 00 000 000000	GIFTED EDUCATION	0.00	0.00		0.00	0.00	0.00
Education Fund	10 R 3360 0000 00 000 000000	STATE FREE LUNCH & BRKFST	500.00	206.00	0.00	-1,010.11	1,510.11	302.02
Education Fund	10 R 3370 0000 00 000 000000	DRIVERS ED REIMBURSEMENT	94,000.00	0.00	0.00	41,660.03	52,339.97	55.68
Education Fund	10 R 3610 0000 00 000 000000	LEARNING IMPR-CHANGE GRNT	0.00	0.00		0.00	0.00	0.00
Education Fund	10 R 3640 0000 00 000 000000	PROF DEVELOP BLOCK GRANT	0.00	0.00		0.00	0.00	0.00
Education Fund	10 R 3696 0000 00 000 000000	REGIONAL SAFE SCHOOLS PROGRAM	0.00	0.00		0.00	0.00	0.00
Education Fund	10 R 3740 0000 00 000 000000	CRIM BACKGROUND CHECKS	0.00	0.00		0.00	0.00	0.00
Education Fund	10 R 3775 0000 00 000 000000	ADA SAFETY BLOCK GRANT	0.00	0.00		0.00	0.00	0.00
Education Fund	10 R 3781 0000 00 000 000000	TECH INTEGRATION GRANT	0.00	0.00		0.00	0.00	0.00
Education Fund	10 R 3792 0000 00 000 000000	TECH-CLOSING THE GAP	0.00	0.00		0.00	0.00	0.00
Education Fund	10 R 3800 0000 00 000 000000	STATE LIBRARY GRANT	0.00	0.00		0.00	0.00	0.00
Education Fund	10 R 3998 0000 00 000 000000	RECEIPTS/REVENUE ON BEHALF PAYMENTS	0.00	0.00	0.00	0.00	0.00	0.00
Education Fund	10 R 3999 0000 00 000 000000	OTH GRANTS-IN-AID/STATE SOURCE	0.00	0.00		0.00	0.00	0.00
Education Fund	10 R 4100 0000 00 000 000000	TITLE V	0.00	0.00		0.00	0.00	0.00
Education Fund	10 R 4101 0000 00 000 000000	HOMELESS GRANT	0.00	0.00		0.00	0.00	0.00
Education Fund	10 R 4215 0000 00 000 000000	SPECIAL MILK PROGRAM	0.00	0.00		0.00	0.00	0.00
Education Fund	10 R 4225 0000 00 000 000000	Summer Foods Program	0.00	0.00		0.00	0.00	0.00
Education Fund	10 R 4300 0000 00 000 000000	TITLE I	58,956.00	0.00	0.00	-24,169.00	83,125.00	140.99
Education Fund	10 R 4400 0000 00 000 000000	TITLE IV DRUG FREE GRANT	2,000.00	0.00	0.00	2,000.00	0.00	0.00
Education Fund	10 R 4620 0000 00 000 000000	SPEC ED-IDEA FLOW THRU	493,774.00	-75,832.00	0.00	-12,088.00	505,862.00	102.45
Education Fund	10 R 4620 0000 00 000 223000	ARP IDEA FLOW-THROUGH	0.00	75,832.00	0.00	-75,832.00	75,832.00	0.00
Education Fund	10 R 4625 0000 00 000 000000	SPEC ED-IDEA-RM & BOARD	0.00	0.00	0.00	0.00	0.00	0.00
Education Fund	10 R 4745 0000 00 000 000000	AG EDUC GRANT	0.00	0.00	0.00	0.00	0.00	0.00
Education Fund	10 R 4850 0000 00 000 000000	ARRA - GENERAL STATE AID	0.00	0.00		0.00	0.00	0.00
Education Fund	10 R 4870 0000 00 000 000000	ARRA -GSA-SFSF	0.00	0.00		0.00	0.00	0.00

250

# Revenue Report

Fiscal Year: 2023-2024  
Month: March

COUNTY OF GRUNDY SCHOOL DIST 111

Fund Description	Account Number	Account Description	Revised Budget	Monthly Activity	Pending Activity	Available Funds	Year to Date Activity	Percent of Budget Used
Education Fund	10 R 4880 0000 00 000 000000	ARRA-Educ Jobs Fund Prgm	0.00	0.00		0.00	0.00	0.00
Education Fund	10 R 4930 0000 00 000 000000	TITLE II EISENHWR PROF DVLPMT	0.00	0.00		0.00	0.00	0.00
Education Fund	10 R 4932 0000 00 000 000000	Title II - Teacher Quality	41,046.00	0.00	0.00	-11,885.00	52,931.00	128.96
Education Fund	10 R 4935 0000 00 000 000000	TITLE II EISENHWR MATH/SCI	0.00	0.00		0.00	0.00	0.00
Education Fund	10 R 4971 0000 00 000 000000	TITLE II PART D TECH GRANT	0.00	0.00		0.00	0.00	0.00
Education Fund	10 R 4991 0000 00 000 000000	MEDICAID/ADMN OUTREACH	22,000.00	1,164.40	0.00	10,927.34	11,072.66	50.33
Education Fund	10 R 4992 0000 00 000 000000	MEDICAID MATCHING	0.00	0.00	0.00	0.00	0.00	0.00
Education Fund	10 R 4998 0000 00 000 223000	ARP - IDEA	75,832.00	0.00	0.00	46,702.00	29,130.00	38.41
Education Fund	10 R 4998 0000 00 000 499801	DIGITAL EQUITY GRANT	0.00	0.00	0.00	-89,160.00	89,160.00	0.00
Education Fund	10 R 4998 0000 00 000 499803	ESSER III	325,000.00	0.00	0.00	30,656.00	294,344.00	90.57
Education Fund	10 R 7110 0000 00 000 000000	PERM TRANS FROM W/C-ABATEMENT	0.00	0.00		0.00	0.00	0.00
Education Fund	10 R 7180 0000 00 000 000000	PERM TRANS FROM W/C-ABATEMENT	0.00	0.00		0.00	0.00	0.00
Education Fund	10 R 7900 0000 00 000 000000	DEBT PROCEEDS	0.00	0.00		0.00	0.00	0.00
Education Fund	10 R 9601 0000 00 000 000000	TIF SURPLUS DONATION	0.00	0.00		0.00	0.00	0.00
<b>10 - -----</b>	<b>Education Fund</b>	<b>TIF SURPLUS DONATION</b>	<b>45,752,766.57</b>	<b>1,491,701.56</b>	<b>0.00</b>	<b>11,996,246.72</b>	<b>33,756,519.85</b>	<b>251</b>
Activity Fund	11 R 1799 0000 00 000 000000	ACTIVITY FUND ACCOUNT	0.00	0.00		0.00	0.00	0.00
Activity Fund	11 R 1799 0000 01 000 900000	COADY SCHOLARSHIP	10,000.00	1,202.31	0.00	-542.34	10,542.34	105.42
Activity Fund	11 R 1799 0000 30 300 910001	SPORTS - ATHLETIC HALL OF FAME	0.00	0.00		0.00	0.00	0.00
Activity Fund	11 R 1799 0000 30 300 910002	SPORTS - ATHLETIC POP	7,000.00	120.92	0.00	6,279.31	720.69	10.30
Activity Fund	11 R 1799 0000 30 300 910003	SPORTS - ATHLETIC TRAINING	0.00	0.00	0.00	-300.00	300.00	0.00
Activity Fund	11 R 1799 0000 30 300 910004	SPORTS - BASEBALL	18,100.00	79.00	0.00	17,421.00	679.00	3.75
Activity Fund	11 R 1799 0000 30 300 910005	SPORTS - BOYS BASKETBALL	17,200.00	0.00	0.00	5,906.22	11,293.78	65.66
Activity Fund	11 R 1799 0000 30 300 910006	SPORTS - BOYS BOWLING	3,700.00	0.00		3,700.00	0.00	0.00
Activity Fund	11 R 1799 0000 30 300 910007	SPORTS - BOYS GOLF	3,200.00	0.00	0.00	2,800.00	400.00	12.50
Activity Fund	11 R 1799 0000 30 300 910008	SPORTS - BOYS SOCCER	20,100.00	0.00	0.00	5,861.27	14,238.73	70.84
Activity Fund	11 R 1799 0000 30 300 910009	SPORTS - BOYS TENNIS	1,800.00	0.00	0.00	1,055.92	744.08	41.34

# Revenue Report

Fiscal Year: 2023-2024  
Month: March

COUNTY OF GRUNDY SCHOOL DIST 111

Fund Description	Account Number	Account Description	Revised Budget	Monthly Activity	Pending Activity	Available Funds	Year to Date Activity	Percent of Budget Used
Activity Fund	11 R 1799 0000 30 300 910010	SPORTS - BOYS TRACK	16,700.00	21,060.00	0.00	-5,370.00	22,070.00	132.16
Activity Fund	11 R 1799 0000 30 300 910011	SPORTS - BOYS VOLLEYBALL	6,500.00	0.00	0.00	6,240.00	260.00	4.00
Activity Fund	11 R 1799 0000 30 300 910012	SPORTS - CHEERLEADERS	46,400.00	0.00	0.00	-2,429.06	48,829.06	105.24
Activity Fund	11 R 1799 0000 30 300 910013	SPORTS - CROSS COUNTY CO ED	4,400.00	0.00	0.00	-3,156.29	7,556.29	171.73
Activity Fund	11 R 1799 0000 30 300 910014	SPORTS - FOOTBALL	85,000.00	0.00	0.00	-35,407.45	120,407.45	141.66
Activity Fund	11 R 1799 0000 30 300 910015	SPORTS - FOOTBALL JERSEYS	0.00	0.00		0.00	0.00	0.00
Activity Fund	11 R 1799 0000 30 300 910016	SPORTS - GIRLS BASKETBALL	8,800.00	0.00	0.00	-1,553.36	10,353.36	117.65
Activity Fund	11 R 1799 0000 30 300 910017	SPORTS - GIRLS BOWLING	3,400.00	0.00	0.00	2,126.00	1,274.00	37.47
Activity Fund	11 R 1799 0000 30 300 910018	SPORTS - GIRLS GOLF	600.00	0.00	0.00	275.00	325.00	54.17
Activity Fund	11 R 1799 0000 30 300 910019	SPORTS - GIRLS SOCCER	11,100.00	0.00	0.00	10,800.00	300.00	2.70
Activity Fund	11 R 1799 0000 30 300 910020	SPORTS - GIRLS TENNIS	3,800.00	0.00	0.00	36.92	3,763.08	99.03
Activity Fund	11 R 1799 0000 30 300 910021	SPORTS - GIRLS TRACK	3,400.00	25.00	0.00	2,649.43	750.57	252 22.08
Activity Fund	11 R 1799 0000 30 300 910022	SPORTS - GIRLS VOLLEYBALL	11,400.00	0.00	0.00	-2,019.45	13,419.45	117.71
Activity Fund	11 R 1799 0000 30 300 910023	SPORTS - LACROSSE	2,300.00	0.00	0.00	2,580.00	-280.00	-12.17
Activity Fund	11 R 1799 0000 30 300 910024	SPORTS - OUTDOOR ED TRIP	2,200.00	2,680.00	0.00	-3,360.00	5,560.00	252.73
Activity Fund	11 R 1799 0000 30 300 910025	SPORTS - POMS	61,600.00	4,971.20	0.00	18,632.15	42,967.85	69.75
Activity Fund	11 R 1799 0000 30 300 910026	SPORTS - SOFTBALL	17,700.00	0.00	0.00	14,244.43	3,455.57	19.52
Activity Fund	11 R 1799 0000 30 300 910027	SPORTS - SWIMMING B&G	600.00	0.00	0.00	-100.00	700.00	116.67
Activity Fund	11 R 1799 0000 30 300 910028	SPORTS - BOYS WRESTLING	10,300.00	0.00	0.00	448.00	9,852.00	95.65
Activity Fund	11 R 1799 0000 30 300 910029	SUMMER CAMPS - BAND CAMP	25,400.00	0.00		25,400.00	0.00	0.00
Activity Fund	11 R 1799 0000 30 300 910030	SUMMER CAMPS - BASEBALL	0.00	0.00		0.00	0.00	0.00
Activity Fund	11 R 1799 0000 30 300 910031	SUMMER CAMPS - BOYS BASKETBALL	10,900.00	0.00	0.00	10,941.58	-41.58	-0.38
Activity Fund	11 R 1799 0000 30 300 910032	SUMMER CAMPS - COED POLE VAULT	700.00	0.00	0.00	1,420.00	-720.00	-102.86
Activity Fund	11 R 1799 0000 30 300 910033	SUMMER CAMPS - CHEERLEADING	2,300.00	0.00	0.00	2,650.00	-350.00	-15.22
Activity Fund	11 R 1799 0000 30 300 910034	SUMMER CAMPS - CROSS COUNTRY	11,000.00	0.00	0.00	11,803.29	-803.29	-7.30

# Revenue Report

Fiscal Year: 2023-2024  
Month: March

COUNTY OF GRUNDY SCHOOL DIST 111

Fund Description	Account Number	Account Description	Revised Budget	Monthly Activity	Pending Activity	Available Funds	Year to Date Activity	Percent of Budget Used
Activity Fund	11 R 1799 0000 30 300 910035	SUMMER CAMPS - FOOTBALL	47,700.00	0.00	0.00	56,114.75	-8,414.75	-17.64
Activity Fund	11 R 1799 0000 30 300 910036	SUMMER CAMPS - GIRLS BASKETBALL	5,600.00	0.00	0.00	5,034.69	565.31	10.09
Activity Fund	11 R 1799 0000 30 300 910037	SUMMER CAMPS - GIRLS VOLLEYBALL	17,500.00	0.00	0.00	15,179.98	2,320.02	13.26
Activity Fund	11 R 1799 0000 30 300 910038	SUMMER CAMPS - POMS	6,100.00	0.00	0.00	6,350.00	-250.00	-4.10
Activity Fund	11 R 1799 0000 30 300 910039	SUMMER CAMPS - SOCCER	4,800.00	800.00	0.00	3,659.72	1,140.28	23.76
Activity Fund	11 R 1799 0000 30 300 910040	SUMMER CAMPS - CONDITIONING	3,100.00	0.00	0.00	2,762.28	337.72	10.89
Activity Fund	11 R 1799 0000 30 300 910041	SUMMER CAMPS - TENNIS CO-ED	7,200.00	0.00	0.00	5,813.16	1,386.84	19.26
Activity Fund	11 R 1799 0000 30 300 910042	SUMMER CAMPS - WOMENS FITNESS	0.00	0.00	0.00	0.00	0.00	0.00
Activity Fund	11 R 1799 0000 30 300 910043	FOOTBALL TEAM CAMP	22,400.00	0.00	0.00	21,920.00	480.00	2.14
Activity Fund	11 R 1799 0000 30 300 910044	SPORTS - GIRLS WRESTLING	4,800.00	0.00	0.00	-5,004.40	9,804.40	204.26
Activity Fund	11 R 1799 0000 30 300 910045	SUMMER CAMPS - SOFTBALL	3,600.00	0.00	0.00	6,240.00	-2,640.00	253 -73.33
Activity Fund	11 R 1799 0000 30 300 910046	SUMMER CAMPS - BOYS VOLLEYBALL	100.00	0.00	0.00	-20.00	120.00	120.00
Activity Fund	11 R 1799 0000 30 300 920000	ATHLETIC BOOSTERS	10,000.00	0.00	0.00	10,000.00	0.00	0.00
Activity Fund	11 R 1799 0000 70 300 900001	ACTIVITIES - POP	19,600.00	120.92	0.00	15,502.78	4,097.22	20.90
Activity Fund	11 R 1799 0000 70 300 900002	ACTIVITIES - ART CLUB	0.00	0.00	0.00	0.00	0.00	0.00
Activity Fund	11 R 1799 0000 70 300 900003	ACTIVITIES - ATHLETIC LEADERSHIP	0.00	0.00	0.00	0.00	0.00	0.00
Activity Fund	11 R 1799 0000 70 300 900004	ACTIVITIES - BAND	0.00	0.00	0.00	0.00	0.00	0.00
Activity Fund	11 R 1799 0000 70 300 900005	ACTIVITIES - CHESS	0.00	0.00	0.00	0.00	0.00	0.00
Activity Fund	11 R 1799 0000 70 300 900006	ACTIVITIES - PHOTOGRAPHY	0.00	0.00	0.00	0.00	0.00	0.00
Activity Fund	11 R 1799 0000 70 300 900007	ACTIVITIES - CHORUS	900.00	0.00	0.00	900.00	0.00	0.00
Activity Fund	11 R 1799 0000 70 300 900008	ACTIVITIES - CLASS OF 2025	14,000.00	20.16	0.00	-1,517.47	15,517.47	110.84
Activity Fund	11 R 1799 0000 70 300 900009	ACTIVITIES - CLASS OF 2026	2,500.00	0.00	0.00	2,500.00	0.00	0.00
Activity Fund	11 R 1799 0000 70 300 900010	ACTIVITIES - CLASS OF 2027	0.00	0.00	0.00	0.00	0.00	0.00
Activity Fund	11 R 1799 0000 70 300 900011	ACTIVITIES - CLASS OF 2028	0.00	0.00	0.00	0.00	0.00	0.00

# Revenue Report

Fiscal Year: 2023-2024  
Month: March

COUNTY OF GRUNDY SCHOOL DIST 111

Fund Description	Account Number	Account Description	Revised Budget	Monthly Activity	Pending Activity	Available Funds	Year to Date Activity	Percent of Budget Used
Activity Fund	11 R 1799 0000 70 300 900012	ACTIVITIES - CLASS OF 2023	0.00	0.00		0.00	0.00	0.00
Activity Fund	11 R 1799 0000 70 300 900013	ACTIVITIES - CLASS OF 2024	5,000.00	20.16	0.00	4,651.53	348.47	6.97
Activity Fund	11 R 1799 0000 70 300 900014	ACTIVITIES - COMMUNITY GARDEN	0.00	0.00		0.00	0.00	0.00
Activity Fund	11 R 1799 0000 70 300 900015	ACTIVITIES - CULINARY ARTS	0.00	0.00		0.00	0.00	0.00
Activity Fund	11 R 1799 0000 70 300 900016	ACTIVITIES - MOCK TRIAL	0.00	0.00		0.00	0.00	0.00
Activity Fund	11 R 1799 0000 70 300 900017	ACTIVITIES - DREAM	0.00	0.00		0.00	0.00	0.00
Activity Fund	11 R 1799 0000 70 300 900018	ACTIVITIES - FASHION MERCHANDISING	0.00	0.00		0.00	0.00	0.00
Activity Fund	11 R 1799 0000 70 300 900019	ACTIVITIES - FCCLA	0.00	0.00		0.00	0.00	0.00
Activity Fund	11 R 1799 0000 70 300 900020	ACTIVITIES - FFA	4,300.00	0.00	0.00	3,225.00	1,075.00	25.00
Activity Fund	11 R 1799 0000 70 300 900021	ACTIVITIES - FRENCH NHS	0.00	0.00		0.00	0.00	0.00
Activity Fund	11 R 1799 0000 70 300 900022	ACTIVITIES - FUTURE BUSINESS LEADERS	0.00	0.00		0.00	0.00	0.00
Activity Fund	11 R 1799 0000 70 300 900023	ACTIVITIES - I.O.T.A.	500.00	0.00	0.00	220.00	280.00	56.00
Activity Fund	11 R 1799 0000 70 300 900024	ACTIVITIES - INDIAN CLIMBING CLUB	600.00	0.00		600.00	0.00	0.00
Activity Fund	11 R 1799 0000 70 300 900025	ACTIVITIES - INDIAN NATION	0.00	0.00		0.00	0.00	0.00
Activity Fund	11 R 1799 0000 70 300 900026	ACTIVITIES - INT'L CLUB	4,200.00	0.00	0.00	4,020.00	180.00	4.29
Activity Fund	11 R 1799 0000 70 300 900027	ACTIVITIES - THEATER CLUB	8,700.00	0.00	0.00	-954.13	9,654.13	110.97
Activity Fund	11 R 1799 0000 70 300 900028	ACTIVITIES - INTERACT	0.00	0.00	0.00	-300.00	300.00	0.00
Activity Fund	11 R 1799 0000 70 300 900029	ACTIVITIES - INVESTMENT CLUB	0.00	0.00		0.00	0.00	0.00
Activity Fund	11 R 1799 0000 70 300 900030	ACTIVITIES - JUDO	200.00	0.00		200.00	0.00	0.00
Activity Fund	11 R 1799 0000 70 300 900031	ACTIVITIES - KALEIDOSOPE	0.00	0.00		0.00	0.00	0.00
Activity Fund	11 R 1799 0000 70 300 900032	ACTIVITIES - MAC	5,000.00	0.00	0.00	409.68	4,590.32	91.81
Activity Fund	11 R 1799 0000 70 300 900033	ACTIVITIES - MATH TEAM	0.00	0.00		0.00	0.00	0.00
Activity Fund	11 R 1799 0000 70 300 900034	ACTIVITIES - MCHS BOOK CLUB	0.00	0.00		0.00	0.00	0.00
Activity Fund	11 R 1799 0000 70 300 900035	ACTIVITIES - MEMORIAL GARDEN	0.00	0.00		0.00	0.00	0.00
Activity Fund	11 R 1799 0000 70 300 900036	ACTIVITIES - MUSICAL	1,500.00	428.70	0.00	1,071.30	428.70	28.58

254

# Revenue Report

Fiscal Year: 2023-2024  
Month: March

COUNTY OF GRUNDY SCHOOL DIST 111

Fund Description	Account Number	Account Description	Revised Budget	Monthly Activity	Pending Activity	Available Funds	Year to Date Activity	Percent of Budget Used
Activity Fund	11 R 1799 0000 70 300 900037	ACTIVITIES - NEEDY FAMILIES	8,500.00	0.00	0.00	1,580.44	6,919.56	81.41
Activity Fund	11 R 1799 0000 70 300 900038	ACTIVITIES - NHS	2,000.00	0.00	0.00	2,000.00	0.00	0.00
Activity Fund	11 R 1799 0000 70 300 900039	ACTIVITIES - ORCHESIS	4,100.00	1,139.60	0.00	2,960.40	1,139.60	27.80
Activity Fund	11 R 1799 0000 70 300 900040	ACTIVITIES - PAC RESTORATION	4,500.00	1,333.00	0.00	2,248.17	2,251.83	50.04
Activity Fund	11 R 1799 0000 70 300 900041	ACTIVITIES - PERCUSSION	18,000.00	0.00	0.00	5,950.00	12,050.00	66.94
Activity Fund	11 R 1799 0000 70 300 900042	ACTIVITIES - GAME CLUB	0.00	0.00		0.00	0.00	0.00
Activity Fund	11 R 1799 0000 70 300 900043	ACTIVITIES - NEWSPAPER	100.00	0.00	0.00	-567.00	667.00	667.00
Activity Fund	11 R 1799 0000 70 300 900044	ACTIVITIES - SADD	0.00	0.00		0.00	0.00	0.00
Activity Fund	11 R 1799 0000 70 300 900045	ACTIVITIES - SCHOLASTIC BOWL	0.00	300.00	0.00	-300.00	300.00	0.00
Activity Fund	11 R 1799 0000 70 300 900046	ACTIVITIES - SPANISH NHS	1,900.00	0.00	0.00	1,335.00	565.00	29.74
Activity Fund	11 R 1799 0000 70 300 900047	ACTIVITIES - SPEECH	0.00	0.00		0.00	0.00	0.00
Activity Fund	11 R 1799 0000 70 300 900048	ACTIVITIES - STUDENT COUNCIL	70,200.00	6,240.00	0.00	-2,197.37	72,397.37	255 103.13
Activity Fund	11 R 1799 0000 70 300 900049	ACTIVITIES - TSA	2,400.00	0.00		2,400.00	0.00	0.00
Activity Fund	11 R 1799 0000 70 300 900050	ACTIVITIES - UNDERWATER ROBOTIC	2,500.00	0.00	0.00	2,200.00	300.00	12.00
Activity Fund	11 R 1799 0000 70 300 900051	ACTIVITIES - WINTERGUARD	29,000.00	21,469.62	0.00	-799.62	29,799.62	102.76
Activity Fund	11 R 1799 0000 70 300 900052	ACTIVITIES - WYSE	0.00	0.00		0.00	0.00	0.00
Activity Fund	11 R 1799 0000 70 300 900053	ACTIVITIES - YEARBOOK	2,900.00	0.00	0.00	-12,553.84	15,453.84	532.89
Activity Fund	11 R 1799 0000 70 300 900054	ACTIVITIES - ALLIES IN DIVERSITY	0.00	0.00		0.00	0.00	0.00
Activity Fund	11 R 1799 0000 70 300 900055	CYBRARY	0.00	0.00		0.00	0.00	0.00
Activity Fund	11 R 1799 0000 70 300 900056	FACULTY POP	1,200.00	120.92	0.00	339.93	860.07	71.67
Activity Fund	11 R 1799 0000 70 300 900057	PROJECT INDIAN	0.00	0.00		0.00	0.00	0.00
Activity Fund	11 R 1799 0000 70 300 900058	PROM	136,900.00	0.00	0.00	136,400.00	500.00	0.37
Activity Fund	11 R 1799 0000 70 300 900059	SCHOLARSHIP	39,500.00	0.00		39,500.00	0.00	0.00
Activity Fund	11 R 1799 0000 70 300 900060	ACTIVITIES - DISC GOLF	0.00	0.00		0.00	0.00	0.00
Activity Fund	11 R 1799 0000 70 300 900061	ACTIVITIES - ASL - AMERICAN SIGN LANGUAGE CLUB/NHS	900.00	0.00	0.00	-1,442.00	2,342.00	260.22
Activity Fund	11 R 1799 0000 70 300 900062	GREEN HOUSE	1,100.00	0.00		1,100.00	0.00	0.00

# Revenue Report

Fiscal Year: 2023-2024  
Month: March

COUNTY OF GRUNDY SCHOOL DIST 111

Fund Description	Account Number	Account Description	Revised Budget	Monthly Activity	Pending Activity	Available Funds	Year to Date Activity	Percent of Budget Used
Activity Fund	11 R 1799 0000 70 300 900064	FOUNDATION SCHOLARSHIP	0.00	0.00		0.00	0.00	0.00
Activity Fund	11 R 1799 0000 70 300 900065	FOUNDATION ASSIST MCHS ATHLETICS/ACTIVITIES	100.00	0.00		100.00	0.00	0.00
Activity Fund	11 R 1799 0000 70 300 900066	ACTIVITIES - CONNECTIONS CREW	0.00	173.43	0.00	-173.43	173.43	0.00
Activity Fund	11 R 1799 0000 70 300 920001	BAND BOOSTERS	0.00	0.00		0.00	0.00	0.00
Activity Fund	11 R 1799 0000 70 300 920002	CHOIR BOOSTERS	0.00	0.00		0.00	0.00	0.00
<b>11 - -----</b>	<b>Activity Fund</b>	<b>CHOIR BOOSTERS</b>	<b>953,300.00</b>	<b>62,304.94</b>	<b>0.00</b>	<b>437,692.12</b>	<b>515,607.88</b>	
Operations & Maint Fund	20 R 1110 0000 00 000 000000	PRIOR YEAR TAXES	0.00	0.00		0.00	0.00	0.00
Operations & Maint Fund	20 R 1111 0000 00 000 000000	GRUNDY CO TAXES	1,664,728.00	0.00	0.00	-4,650.09	1,669,378.09	100.28
Operations & Maint Fund	20 R 1112 0000 00 000 000000	KENDALL CO TAXES	238,695.00	0.00	0.00	-2,116.85	240,811.85	100.89
Operations & Maint Fund	20 R 1113 0000 00 000 000000	WILL CO TAXES	1,230,666.00	0.00	0.00	62,282.32	1,168,383.68	94.94
Operations & Maint Fund	20 R 1114 0000 00 000 000000	GRUNDY CO EDPA SURPLUS	0.00	0.00		0.00	0.00	256
Operations & Maint Fund	20 R 1122 0000 00 000 000000	KENDALL CO - EARLY DISTR	356,129.53	0.00		356,129.53	0.00	0.00
Operations & Maint Fund	20 R 1123 0000 00 000 000000	WILL CO - EARLY DISTR	1,237,312.04	0.00		1,237,312.04	0.00	0.00
Operations & Maint Fund	20 R 1210 0000 00 000 000000	MOBILE HOME TAX	0.00	0.00		0.00	0.00	0.00
Operations & Maint Fund	20 R 1211 0000 00 000 000000	GRUNDY CO TORT	0.00	0.00		0.00	0.00	0.00
Operations & Maint Fund	20 R 1212 0000 00 000 000000	KENDALL CO TORT	0.00	0.00		0.00	0.00	0.00
Operations & Maint Fund	20 R 1213 0000 00 000 000000	WILL CO TORT	0.00	0.00		0.00	0.00	0.00
Operations & Maint Fund	20 R 1222 0000 00 000 000000	KENDALL CO TORT-EARLY DIST	0.00	0.00		0.00	0.00	0.00
Operations & Maint Fund	20 R 1223 0000 00 000 000000	WILL CO TORT-EARLY DISTR	0.00	0.00		0.00	0.00	0.00
Operations & Maint Fund	20 R 1230 0000 00 000 000000	CPPRT	383,407.00	28,488.32	0.00	115,747.69	267,659.31	69.81
Operations & Maint Fund	20 R 1290 0000 00 000 000000	ESCROW PMTS/LIEU OF TAXES	0.00	0.00		0.00	0.00	0.00
Operations & Maint Fund	20 R 1311 0000 00 000 000000	GRUNDY CO LEASE	0.00	0.00		0.00	0.00	0.00
Operations & Maint Fund	20 R 1312 0000 00 000 000000	KENDALL CO LEASE	0.00	0.00		0.00	0.00	0.00
Operations & Maint Fund	20 R 1313 0000 00 000 000000	WILL CO LEASE	0.00	0.00		0.00	0.00	0.00
Operations & Maint Fund	20 R 1322 0000 00 000 000000	KENDALL CO LEASE-EARLY DISTR	0.00	0.00		0.00	0.00	0.00

# Revenue Report

Fiscal Year: 2023-2024  
Month: March

COUNTY OF GRUNDY SCHOOL DIST 111

Fund Description	Account Number	Account Description	Revised Budget	Monthly Activity	Pending Activity	Available Funds	Year to Date Activity	Percent of Budget Used
Operations & Maint Fund	20 R 1323 0000 00 000 000000	WILL CO LEASE-EARLY DISTR	0.00	0.00		0.00	0.00	0.00
Operations & Maint Fund	20 R 1510 0000 00 000 000000	CHECKING INTEREST	0.00	0.00		0.00	0.00	0.00
Operations & Maint Fund	20 R 1511 0000 00 000 000000	INVESTMENT INTEREST	200,000.00	11,614.97	0.00	4,036.63	195,963.37	97.98
Operations & Maint Fund	20 R 1910 0000 00 000 000000	CLASSROOM RENTAL	0.00	0.00		0.00	0.00	0.00
Operations & Maint Fund	20 R 1911 0000 00 000 000000	BUILDING RENTAL	25,000.00	0.00	0.00	13,659.51	11,340.49	45.36
Operations & Maint Fund	20 R 1912 0000 00 000 000000	FARM LEASE PAYMENTS	47,000.00	0.00	0.00	-1,566.78	48,566.78	103.33
Operations & Maint Fund	20 R 1950 0000 00 000 000000	REFUND OF PRIOR YR EXPENSES	0.00	0.00		0.00	0.00	0.00
Operations & Maint Fund	20 R 1960 0000 00 000 000000	GRUNDY COUNTY EDUCATION TIF	0.00	0.00	0.00	0.00	0.00	0.00
Operations & Maint Fund	20 R 1991 0000 00 000 000000	SP ED HOUSING ASSESMENT	0.00	0.00		0.00	0.00	0.00
Operations & Maint Fund	20 R 1996 0000 00 000 000000	SALE OF CROPS	0.00	0.00		0.00	0.00	0.00
Operations & Maint Fund	20 R 1997 0000 00 000 000000	INSURANCE	0.00	0.00		0.00	0.00	0.00
Operations & Maint Fund	20 R 1998 0000 00 000 000000	SALE OF EQUIPMENT	0.00	0.00		0.00	0.00	257
Operations & Maint Fund	20 R 1999 0000 00 000 000000	OTHER-LOCAL SOURCES	13,000.00	0.00	0.00	8,861.45	4,138.55	31.84
Operations & Maint Fund	20 R 1999 2220 00 000 000000	DIST 111 GROUP MEDICAL REVENUE	261,080.51	24,378.70	0.00	53,381.54	207,698.97	79.55
Operations & Maint Fund	20 R 1999 2230 00 000 000000	DIST 111 GROUP DENTAL REVENUE	11,757.88	1,121.52	0.00	2,080.04	9,677.84	82.31
Operations & Maint Fund	20 R 3925 0000 00 000 000000	SCHOOL MAINTENANCE PROJECTS	0.00	0.00		0.00	0.00	0.00
Operations & Maint Fund	20 R 3999 0000 00 000 000000	OTH GRANTS-IN-AID/STATE SOURCE	0.00	0.00		0.00	0.00	0.00
Operations & Maint Fund	20 R 4590 0000 00 000 000000	COPS GRANT - MINOOKA	0.00	0.00		0.00	0.00	0.00
Operations & Maint Fund	20 R 4998 0000 00 000 499801	ESSER 1	0.00	0.00		0.00	0.00	0.00
Operations & Maint Fund	20 R 4998 0000 00 000 499802	ESSER II	0.00	0.00		0.00	0.00	0.00
Operations & Maint Fund	20 R 4998 0000 00 000 499803	ESSER III	0.00	0.00		0.00	0.00	0.00
Operations & Maint Fund	20 R 7110 0000 00 000 000000	PERM TRANS FROM W/C- ABATEMENT	0.00	0.00		0.00	0.00	0.00
Operations & Maint Fund	20 R 7130 0000 00 000 000000	PERM TRANS AMONG FUNDS	0.00	0.00	0.00	0.00	0.00	0.00
Operations & Maint Fund	20 R 7900 0000 00 000 000000	DEBT PROCEEDS	0.00	0.00		0.00	0.00	0.00
Operations & Maint Fund	20 R 8410 0000 00 000 000000	TAXES PLEDGED/PRINC-CAP LEASE	0.00	0.00		0.00	0.00	0.00

# Revenue Report

Fiscal Year: 2023-2024  
Month: March

COUNTY OF GRUNDY SCHOOL DIST 111

Fund Description	Account Number	Account Description	Revised Budget	Monthly Activity	Pending Activity	Available Funds	Year to Date Activity	Percent of Budget Used
Operations & Maint Fund	20 R 9601 0000 00 000 000000	TIF SURPLUS DONATION	0.00	0.00		0.00	0.00	0.00
<b>20 - -----</b>	<b>Operations &amp; Maint Fund</b>	<b>TIF SURPLUS DONATION</b>	<b>5,668,775.96</b>	<b>65,603.51</b>	<b>0.00</b>	<b>1,845,157.03</b>	<b>3,823,618.93</b>	
Debt Service Fund or Fund Group	30 R 1110 0000 00 000 000000	PRIOR YEAR TAXES	0.00	0.00		0.00	0.00	0.00
Debt Service Fund or Fund Group	30 R 1111 0000 00 000 000000	GRUNDY CO TAXES	3,055,577.00	0.00	0.00	-8,465.36	3,064,042.36	100.28
Debt Service Fund or Fund Group	30 R 1112 0000 00 000 000000	KENDALL CO TAXES	435,112.00	0.00	0.00	-3,859.11	438,971.11	100.89
Debt Service Fund or Fund Group	30 R 1113 0000 00 000 000000	WILL CO TAXES	2,195,738.00	0.00	0.00	79,561.50	2,116,176.50	96.38
Debt Service Fund or Fund Group	30 R 1114 0000 00 000 000000	GRUNDY CO EPDA SURPLUS	0.00	0.00		0.00	0.00	0.00
Debt Service Fund or Fund Group	30 R 1122 0000 00 000 000000	KENDALL CO - EARLY DISTR	649,181.73	0.00		649,181.73	0.00	0.00
Debt Service Fund or Fund Group	30 R 1123 0000 00 000 000000	WILL CO - EARLY DISTR	2,241,019.59	0.00		2,241,019.59	0.00	0.00
Debt Service Fund or Fund Group	30 R 1210 0000 00 000 000000	MOBILE HOME TAX	0.00	0.00		0.00	0.00	0.00
Debt Service Fund or Fund Group	30 R 1290 0000 00 000 000000	PAYMENT IN LIEU OF TAXES BONDS	0.00	0.00		0.00	0.00	0.00
Debt Service Fund or Fund Group	30 R 1301 0000 00 000 000000	GRUNDY CO LEASE	0.00	0.00		0.00	0.00	0.00
Debt Service Fund or Fund Group	30 R 1302 0000 00 000 000000	KENDALL CO LEASE	0.00	0.00		0.00	0.00	0.00
Debt Service Fund or Fund Group	30 R 1303 0000 00 000 000000	WILL CO LEASE	0.00	0.00		0.00	0.00	0.00
Debt Service Fund or Fund Group	30 R 1323 0000 00 000 000000	WILL CO LEASE-EARLY DIST	0.00	0.00		0.00	0.00	0.00
Debt Service Fund or Fund Group	30 R 1510 0000 00 000 000000	CHECKING INTEREST	0.00	0.00		0.00	0.00	0.00
Debt Service Fund or Fund Group	30 R 1511 0000 00 000 000000	INVESTMENT INTEREST	200,000.00	26,226.65	0.00	-26,655.62	226,655.62	113.33
Debt Service Fund or Fund Group	30 R 1512 0000 00 000 000000	BOND INTEREST	0.00	0.00		0.00	0.00	0.00
Debt Service Fund or Fund Group	30 R 1960 0000 00 000 000000	GRUNDY COUNTY EDUCATION TIF	0.00	0.00	0.00	0.00	0.00	0.00
Debt Service Fund or Fund Group	30 R 1999 0000 00 000 000000	OTHER-LOCAL SOURCES	0.00	0.00		0.00	0.00	0.00
Debt Service Fund or Fund Group	30 R 7210 0000 00 000 000000	PRINCIPAL ON BONDS SOLD	0.00	0.00		0.00	0.00	0.00
Debt Service Fund or Fund Group	30 R 7210 0000 00 000 000001	PREMIUM ON BONDS SOLD	0.00	0.00		0.00	0.00	0.00

258

# Revenue Report

Fiscal Year: 2023-2024  
Month: March

COUNTY OF GRUNDY SCHOOL DIST 111

Fund Description	Account Number	Account Description	Revised Budget	Monthly Activity	Pending Activity	Available Funds	Year to Date Activity	Percent of Budget Used
Debt Service Fund or Fund Group	30 R 7220 0000 00 000 000000	PREMIUM ON BONDS SOLD	0.00	0.00		0.00	0.00	0.00
Debt Service Fund or Fund Group	30 R 7230 0000 00 000 000000	INTEREST ON BONDS SOLD	0.00	0.00		0.00	0.00	0.00
Debt Service Fund or Fund Group	30 R 7400 0000 00 000 000000	TRANS FROM OTHER FUNDS	0.00	0.00		0.00	0.00	0.00
Debt Service Fund or Fund Group	30 R 7401 0000 00 000 000000	TRANS FROM OBM LEASE	0.00	0.00		0.00	0.00	0.00
Debt Service Fund or Fund Group	30 R 7500 0000 00 000 000000	TRANS FROM OTHER FUNDS	0.00	0.00		0.00	0.00	0.00
Debt Service Fund or Fund Group	30 R 8990 0000 00 000 000000	DISCOUNT ON BONDS SOLD	0.00	0.00		0.00	0.00	0.00
Debt Service Fund or Fund Group	30 R 8991 0000 00 000 000000	REFUNDED PRINCIPAL	0.00	0.00		0.00	0.00	0.00
Debt Service Fund or Fund Group	30 R 8992 0000 00 000 000000	REFUNDED INTEREST	0.00	0.00		0.00	0.00	0.00
Debt Service Fund or Fund Group	30 R 9601 0000 00 000 000000	TIF SURPLUS DONATION	0.00	0.00		0.00	0.00	0.00
<b>30 - -----</b>	<b>Debt Service Fund or Fund</b>	<b>TIF SURPLUS DONATION</b>	<b>8,776,628.32</b>	<b>26,226.65</b>	<b>0.00</b>	<b>2,930,782.73</b>	<b>5,845,845.59</b>	<b>259</b>
Transportation Fund	40 R 1110 0000 00 000 000000	PRIOR YEAR TAXES	0.00	0.00		0.00	0.00	0.00
Transportation Fund	40 R 1111 0000 00 000 000000	GRUNDY CO TAXES	799,069.00	0.00	0.00	-2,226.91	801,295.91	100.28
Transportation Fund	40 R 1112 0000 00 000 000000	KENDALL CO TAXES	114,574.00	0.00	0.00	-1,015.68	115,589.68	100.89
Transportation Fund	40 R 1113 0000 00 000 000000	WILL CO TAXES	590,720.00	0.00	0.00	29,895.83	560,824.17	94.94
Transportation Fund	40 R 1114 0000 00 000 000000	GRUNDY CO EPDA SURPLUS	0.00	0.00		0.00	0.00	0.00
Transportation Fund	40 R 1122 0000 00 000 000000	KENDALL CO-EARLY DISTR	170,942.21	0.00		170,942.21	0.00	0.00
Transportation Fund	40 R 1123 0000 00 000 000000	WILL CO-EARLY DISTR	593,909.79	0.00		593,909.79	0.00	0.00
Transportation Fund	40 R 1210 0000 00 000 000000	MOBILE HOME TAX	0.00	0.00		0.00	0.00	0.00
Transportation Fund	40 R 1211 0000 00 000 000000	GRUNDY CO TORT	0.00	0.00		0.00	0.00	0.00
Transportation Fund	40 R 1212 0000 00 000 000000	KENDALL CO TORT	0.00	0.00		0.00	0.00	0.00
Transportation Fund	40 R 1213 0000 00 000 000000	WILL CO TORT	0.00	0.00		0.00	0.00	0.00
Transportation Fund	40 R 1223 0000 00 000 000000	WILL CO TORT-EARLY DISTR	0.00	0.00		0.00	0.00	0.00
Transportation Fund	40 R 1230 0000 00 000 000000	CPPRT	0.00	0.00		0.00	0.00	0.00
Transportation Fund	40 R 1290 0000 00 000 000000	PAYMENT IN LIEU OF TAXES TRANS	0.00	0.00		0.00	0.00	0.00
Transportation Fund	40 R 1442 0000 00 000 000000	SP ED TRAN OTHER DISTRICT	0.00	0.00		0.00	0.00	0.00

# Revenue Report

Fiscal Year: 2023-2024  
Month: March

COUNTY OF GRUNDY SCHOOL DIST 111

Fund Description	Account Number	Account Description	Revised Budget	Monthly Activity	Pending Activity	Available Funds	Year to Date Activity	Percent of Budget Used
Transportation Fund	40 R 1510 0000 00 000 000000	CHECKING INTEREST	0.00	0.00		0.00	0.00	0.00
Transportation Fund	40 R 1511 0000 00 000 000000	INVESTMENT INTEREST	125,000.00	14,934.12	0.00	37,611.00	87,389.00	69.91
Transportation Fund	40 R 1950 0000 00 000 000000	REFUND OF PRIOR YR EXPENSES	0.00	0.00	0.00	-30,754.25	30,754.25	0.00
Transportation Fund	40 R 1960 0000 00 000 000000	GRUNDY COUNTY EDUCATION TIF	0.00	0.00	0.00	0.00	0.00	0.00
Transportation Fund	40 R 1998 0000 00 000 000000	SALE OF EQUIPMENT	0.00	0.00		0.00	0.00	0.00
Transportation Fund	40 R 1999 0000 00 000 000000	OTHER-LOCAL SOURCES	0.00	0.00	0.00	-85,397.51	85,397.51	0.00
Transportation Fund	40 R 1999 2220 00 000 000000	DIST 111 GROUP MEDICAL REVENUE	174,421.20	16,629.61	0.00	42,276.18	132,145.02	75.76
Transportation Fund	40 R 1999 2230 00 000 000000	DIST 111 GROUP DENTAL REVENUE	6,072.56	552.23	0.00	1,523.95	4,548.61	74.90
Transportation Fund	40 R 3500 0000 00 000 000000	TRANS - REGULAR REIMB	150,000.00	0.00	0.00	575.81	149,424.19	99.62
Transportation Fund	40 R 3505 0000 00 000 000000	TRANS - VOCATIONAL REIMB	0.00	0.00		0.00	0.00	0.00
Transportation Fund	40 R 3510 0000 00 000 000000	TRANS-SPEC ED REIMB	975,000.00	0.00	0.00	169,673.33	805,326.67	82.60
Transportation Fund	40 R 3999 0000 00 000 000000	OTHER RESTRICTED REV STATE	0.00	0.00		0.00	0.00	0.00
Transportation Fund	40 R 4999 0000 00 000 000000	OTHER RESTRICTED REV FEDERAL	0.00	0.00	0.00	0.00	0.00	0.00
Transportation Fund	40 R 7130 0000 00 000 000000	PERM TRANS AMONG FUNDS	0.00	0.00		0.00	0.00	0.00
Transportation Fund	40 R 7140 0000 00 000 000000	INT TRANS FROM SITE/CONST	0.00	0.00		0.00	0.00	0.00
Transportation Fund	40 R 9601 0000 00 000 000000	TIF SURPLUS DONATION	0.00	0.00		0.00	0.00	0.00
<b>40 - ----</b>	<b>Transportation Fund</b>	<b>TIF SURPLUS DONATION</b>	<b>3,699,708.76</b>	<b>32,115.96</b>	<b>0.00</b>	<b>927,013.75</b>	<b>2,772,695.01</b>	<b>260</b>
I.M.R.F./Soc. Sec. Fund	50 R 1110 0000 00 000 000000	PRIOR YEAR TAXES	0.00	0.00		0.00	0.00	0.00
I.M.R.F./Soc. Sec. Fund	50 R 1111 0000 00 000 000000	GRUNDY CO IMRF	161,145.00	0.00	0.00	-448.34	161,593.34	100.28
I.M.R.F./Soc. Sec. Fund	50 R 1112 0000 00 000 000000	KENDALL CO IMRF	23,173.00	0.00	0.00	-205.02	23,378.02	100.88
I.M.R.F./Soc. Sec. Fund	50 R 1113 0000 00 000 000000	WILL CO IMRF	118,179.00	0.00	0.00	5,079.47	113,099.53	95.70
I.M.R.F./Soc. Sec. Fund	50 R 1114 0000 00 000 000000	GRUNDY CO IMRF EDPA SURPLUS	0.00	0.00		0.00	0.00	0.00
I.M.R.F./Soc. Sec. Fund	50 R 1122 0000 00 000 000000	KENDALL CO-EARLY DISTR	34,573.25	0.00		34,573.25	0.00	0.00
I.M.R.F./Soc. Sec. Fund	50 R 1123 0000 00 000 000000	WILL CO-EARLY DISTR	119,771.80	0.00		119,771.80	0.00	0.00
I.M.R.F./Soc. Sec. Fund	50 R 1210 0000 00 000 000000	MOBILE HOME TAX	0.00	0.00		0.00	0.00	0.00
I.M.R.F./Soc. Sec. Fund	50 R 1211 0000 00 000 000000	MOBILE HOME TAX IMRF	0.00	0.00		0.00	0.00	0.00

# Revenue Report

Fiscal Year: 2023-2024  
Month: March

COUNTY OF GRUNDY SCHOOL DIST 111

Fund Description	Account Number	Account Description	Revised Budget	Monthly Activity	Pending Activity	Available Funds	Year to Date Activity	Percent of Budget Used
I.M.R.F./Soc. Sec. Fund	50 R 1212 0000 00 000 000000	MOBILE HOME TAX SOC SEC	0.00	0.00		0.00	0.00	0.00
I.M.R.F./Soc. Sec. Fund	50 R 1230 0000 00 000 000000	CPPRT	197,513.00	14,675.80	0.00	59,627.91	137,885.09	69.81
I.M.R.F./Soc. Sec. Fund	50 R 1290 0000 00 000 000000	PAYMENT IN LIEU OF TAXES IMRF	0.00	0.00		0.00	0.00	0.00
I.M.R.F./Soc. Sec. Fund	50 R 1291 0000 00 000 000000	PAYMENT IN LIEU OF TAXES SOC SEC	0.00	0.00		0.00	0.00	0.00
I.M.R.F./Soc. Sec. Fund	50 R 1510 0000 00 000 000000	CHECKING INTEREST	0.00	0.00		0.00	0.00	0.00
I.M.R.F./Soc. Sec. Fund	50 R 1511 0000 00 000 000000	INVESTMENT INTEREST	70,000.00	8,631.77	0.00	-6,180.82	76,180.82	108.83
I.M.R.F./Soc. Sec. Fund	50 R 1511 0000 00 000 000001	GRUNDY CO SS	194,777.00	0.00	0.00	-543.82	195,320.82	100.28
I.M.R.F./Soc. Sec. Fund	50 R 1512 0000 00 000 000000	KENDALL CO SS	28,013.00	0.00	0.00	-248.69	28,261.69	100.89
I.M.R.F./Soc. Sec. Fund	50 R 1513 0000 00 000 000000	WILL CO SS	141,842.00	0.00	0.00	5,374.79	136,467.21	96.21
I.M.R.F./Soc. Sec. Fund	50 R 1514 0000 00 000 000000	GRUNDY CO SS EDPA SURPLUS	0.00	0.00		0.00	0.00	0.00
I.M.R.F./Soc. Sec. Fund	50 R 1522 0000 00 000 000000	KENDALL CO SS-EARLY DISTR	41,795.75	0.00		41,795.75	0.00	0.00
I.M.R.F./Soc. Sec. Fund	50 R 1523 0000 00 000 000000	WILL CO SS-EARLY DISTR	144,518.05	0.00		144,518.05	0.00	0.00
I.M.R.F./Soc. Sec. Fund	50 R 1960 0000 00 000 000000	GRUNDY COUNTY EDUCATION TIF	0.00	0.00	0.00	0.00	0.00	0.00
I.M.R.F./Soc. Sec. Fund	50 R 1962 0000 00 000 000000		0.00	0.00	0.00	0.00	0.00	0.00
I.M.R.F./Soc. Sec. Fund	50 R 1999 0000 00 000 000000	OTHER-LOCAL SOURCES	0.00	0.00		0.00	0.00	0.00
I.M.R.F./Soc. Sec. Fund	50 R 9601 0000 00 000 000000	TIF SURPLUS DONATION	0.00	0.00		0.00	0.00	0.00
<b>50 - -----</b>	<b>I.M.R.F./Soc. Sec. Fund</b>	<b>TIF SURPLUS DONATION</b>	<b>1,275,300.85</b>	<b>23,307.57</b>	<b>0.00</b>	<b>403,114.33</b>	<b>872,186.52</b>	<b>261</b>
Capital Projects Fund or Fund Group	60 R 1291 0000 00 000 000000	FACILITIES IMPACT FEES	70,000.00	0.00	0.00	48,976.57	21,023.43	30.03
Capital Projects Fund or Fund Group	60 R 1292 0000 00 000 000000	SCHOOL SITE FEES	55,000.00	0.00	0.00	51,892.42	3,107.58	5.65
Capital Projects Fund or Fund Group	60 R 1510 0000 00 000 000000	CHECKING INTEREST	0.00	0.00		0.00	0.00	0.00
Capital Projects Fund or Fund Group	60 R 1511 0000 00 000 000000	INVESTMENT INTEREST	180,000.00	81,364.32	0.00	-315,894.31	495,894.31	275.50
Capital Projects Fund or Fund Group	60 R 1520 0000 00 000 000000	GAIN/LOSS ON INVESTMENTS	0.00	0.00		0.00	0.00	0.00
Capital Projects Fund or Fund Group	60 R 1930 0000 00 000 000000	IMPACT FEES	3,000.00	0.00	0.00	-3,579.00	6,579.00	219.30
Capital Projects Fund or Fund Group	60 R 1960 0000 00 000 000000	GRUNDY COUNTY EDUCATION TIF	900,000.00	0.00	0.00	0.00	900,000.00	100.00

# Revenue Report

Fiscal Year: 2023-2024  
Month: March

COUNTY OF GRUNDY SCHOOL DIST 111

Fund Description	Account Number	Account Description	Revised Budget	Monthly Activity	Pending Activity	Available Funds	Year to Date Activity	Percent of Budget Used
Capital Projects Fund or Fund Group	60 R 1997 0000 00 000 000000	Insurance	0.00	0.00	0.00	-49,717.64	49,717.64	0.00
Capital Projects Fund or Fund Group	60 R 1999 0000 00 000 000000	OTHER-LOCAL SOURCES	0.00	0.00		0.00	0.00	0.00
Capital Projects Fund or Fund Group	60 R 4590 0000 00 000 000000	COPS GRANT - CHANNAHON	0.00	0.00		0.00	0.00	0.00
Capital Projects Fund or Fund Group	60 R 4998 0000 00 000 499803	ESSER III	505,268.00	0.00	0.00	-30,901.00	536,169.00	106.12
Capital Projects Fund or Fund Group	60 R 7110 0000 00 000 000000	PERM TRANS FROM W/C- ABATEMENT	0.00	0.00		0.00	0.00	0.00
Capital Projects Fund or Fund Group	60 R 7210 0000 00 000 000000	PRINCIPAL ON BONDS SOLD	0.00	0.00		0.00	0.00	0.00
Capital Projects Fund or Fund Group	60 R 7800 0000 00 000 000000	TRANS FROM OTHER FUNDS	0.00	0.00	0.00	0.00	0.00	0.00
Capital Projects Fund or Fund Group	60 R 7840 0000 00 000 000000	Fund Balance Transfer for Capital Projects	2,000,000.00	0.00	0.00	2,000,000.00	0.00	0.00
<b>60 - -----</b>	<b>Capital Projects Fund or</b>	<b>Fund Balance Transfer for</b>	<b>3,713,268.00</b>	<b>81,364.32</b>	<b>0.00</b>	<b>1,700,777.04</b>	<b>2,012,490.96</b>	
Working Cash Fund	70 R 1110 0000 00 000 000000	PRIOR YEAR TAXES	0.00	0.00		0.00	0.00	0.00
Working Cash Fund	70 R 1111 0000 00 000 000000	GRUNDY CO TAXES	332,945.00	0.00	0.00	-924.40	333,869.40	100.28
Working Cash Fund	70 R 1112 0000 00 000 000000	KENDALL CO TAXES	47,739.00	0.00	0.00	-423.37	48,162.37	100.89
Working Cash Fund	70 R 1113 0000 00 000 000000	WILL CO TAXES	246,133.00	0.00	0.00	12,456.27	233,676.73	94.94
Working Cash Fund	70 R 1114 0000 00 000 000000	GRUNDY CO EDPA SURPLUS	0.00	0.00		0.00	0.00	0.00
Working Cash Fund	70 R 1122 0000 00 000 000000	KENDALL CO-EARLY DISTR	71,225.47	0.00		71,225.47	0.00	0.00
Working Cash Fund	70 R 1123 0000 00 000 000000	WILL CO-EARLY DISTR	247,462.42	0.00		247,462.42	0.00	0.00
Working Cash Fund	70 R 1210 0000 00 000 000000	MOBILE HOME TAX	0.00	0.00		0.00	0.00	0.00
Working Cash Fund	70 R 1230 0000 00 000 000000	CPPRT	0.00	0.00		0.00	0.00	0.00
Working Cash Fund	70 R 1290 0000 00 000 000000	PAYMENT IN LIEU OF TAXES WORKING CASH	0.00	0.00		0.00	0.00	0.00
Working Cash Fund	70 R 1510 0000 00 000 000000	CHECKING INTEREST	0.00	0.00		0.00	0.00	0.00
Working Cash Fund	70 R 1511 0000 00 000 000000	INVESTMENT INTEREST	350,000.00	57,555.91	0.00	-39,777.98	389,777.98	111.37
Working Cash Fund	70 R 1960 0000 00 000 000000	TIF SURPLUS DONATION	0.00	0.00		0.00	0.00	0.00
Working Cash Fund	70 R 1999 0000 99 000 000000	OTHER-LOCAL SOURCES	0.00	0.00		0.00	0.00	0.00
Working Cash Fund	70 R 7210 0000 00 000 000000	PRIN ON BONDS SOLD	0.00	0.00		0.00	0.00	0.00
Working Cash Fund	70 R 7220 0000 00 000 000000	PREMIUM ON BONDS SOLD	0.00	0.00		0.00	0.00	0.00
Working Cash Fund	70 R 8110 0000 00 000 000000	ABATEMENT OF W/C FUND	0.00	0.00		0.00	0.00	0.00

# Revenue Report

Fiscal Year: 2023-2024  
Month: March

COUNTY OF GRUNDY SCHOOL DIST 111

Fund Description	Account Number	Account Description	Revised Budget	Monthly Activity	Pending Activity	Available Funds	Year to Date Activity	Percent of Budget Used
<b>70 - -----</b>	<b>Working Cash Fund</b>	<b>ABATEMENT OF W/C FUND</b>	<b>1,295,504.89</b>	<b>57,555.91</b>	<b>0.00</b>	<b>290,018.41</b>	<b>1,005,486.48</b>	
Tort Immunity and Judgment Fund	80 R 1110 0000 00 000 000000	PRIOR YEAR TAXES	0.00	0.00		0.00	0.00	0.00
Tort Immunity and Judgment Fund	80 R 1111 0000 00 000 000000	GRUNDY CO TORT	513,469.00	0.00	0.00	-1,430.96	514,899.96	100.28
Tort Immunity and Judgment Fund	80 R 1112 0000 00 000 000000	KENDALL CO TORT	73,852.00	0.00	0.00	-655.18	74,507.18	100.89
Tort Immunity and Judgment Fund	80 R 1113 0000 00 000 000000	WILL CO TORT	373,804.00	0.00	0.00	14,409.18	359,394.82	96.15
Tort Immunity and Judgment Fund	80 R 1114 0000 00 000 000000	GRUNDY CO TORT EDPA SURPLUS	0.00	0.00		0.00	0.00	0.00
Tort Immunity and Judgment Fund	80 R 1122 0000 00 000 000000	KENDALL CO TORT-EARLY DISTR	110,186.51	0.00		110,186.51	0.00	0.00
Tort Immunity and Judgment Fund	80 R 1123 0000 00 000 000000	WILL CO TORT-EARLY DISTR	380,597.20	0.00		380,597.20	0.00	0.00
Tort Immunity and Judgment Fund	80 R 1210 0000 00 000 000000	MOBILE HOME TAX	0.00	0.00		0.00	0.00	0.00
Tort Immunity and Judgment Fund	80 R 1290 0000 00 000 000000	PAYMENT IN LIEU OF TAXES LIABILITY	0.00	0.00		0.00	0.00	263 0.00
Tort Immunity and Judgment Fund	80 R 1510 0000 00 000 000000	CHECKING INTEREST	0.00	0.00		0.00	0.00	0.00
Tort Immunity and Judgment Fund	80 R 1511 0000 00 000 000000	INVESTMENT INTEREST	70,000.00	3,384.07	0.00	39,267.80	30,732.20	43.90
Tort Immunity and Judgment Fund	80 R 1960 0000 00 000 000000	GRUNDY CO ED TIF	0.00	0.00		0.00	0.00	0.00
Tort Immunity and Judgment Fund	80 R 1999 0000 00 000 000000	OTHER-LOCAL SOURCES	0.00	0.00		0.00	0.00	0.00
Tort Immunity and Judgment Fund	80 R 1999 2220 00 000 000000	DIST 111 GROUP MEDICAL REVENUE	120,125.50	16,315.70	0.00	5,852.96	114,272.54	95.13
Tort Immunity and Judgment Fund	80 R 1999 2230 00 000 000000	DIST 111 GROUP DENTAL REVENUE	2,503.05	576.11	0.00	-353.65	2,856.70	114.13
Tort Immunity and Judgment Fund	80 R 4008 0000 00 000 000000	COPS GRANT CHANNAHON	0.00	0.00		0.00	0.00	0.00
Tort Immunity and Judgment Fund	80 R 4009 0000 00 000 000000	COPS GRANT MINOOKA	0.00	0.00		0.00	0.00	0.00
Tort Immunity and Judgment Fund	80 R 7130 0000 00 000 000000	TRANS FROM ED TORT	0.00	0.00		0.00	0.00	0.00
Tort Immunity and Judgment Fund	80 R 7990 0000 00 000 000000	TRANS FROM OBM TORT	0.00	0.00		0.00	0.00	0.00
<b>80 - -----</b>	<b>Tort Immunity and Judgment</b>	<b>TRANS FROM OBM TORT</b>	<b>1,644,537.26</b>	<b>20,275.88</b>	<b>0.00</b>	<b>547,873.86</b>	<b>1,096,663.40</b>	
Fire Prevention & Safety Fund	90 R 1110 0000 00 000 000000	PRIOR YEAR TAXES	0.00	0.00		0.00	0.00	0.00

# Revenue Report

Fiscal Year: 2023-2024  
Month: March

COUNTY OF GRUNDY SCHOOL DIST 111

Fund Description	Account Number	Account Description	Revised Budget	Monthly Activity	Pending Activity	Available Funds	Year to Date Activity	Percent of Budget Used
Fire Prevention & Safety Fund	90 R 1111 0000 00 000 000000	GRUNDY CO TAXES	332,945.00	0.00	0.00	-924.40	333,869.40	100.28
Fire Prevention & Safety Fund	90 R 1112 0000 00 000 000000	KENDALL CO TAXES	47,739.00	0.00	0.00	-423.37	48,162.37	100.89
Fire Prevention & Safety Fund	90 R 1113 0000 00 000 000000	WILL CO TAXES	246,133.00	0.00	0.00	12,456.27	233,676.73	94.94
Fire Prevention & Safety Fund	90 R 1114 0000 00 000 000000	GRUNDY CO EDPA SURPLUS	0.00	0.00		0.00	0.00	0.00
Fire Prevention & Safety Fund	90 R 1122 0000 00 000 000000	KENDALL CO-EARLY DISTR	71,225.47	0.00		71,225.47	0.00	0.00
Fire Prevention & Safety Fund	90 R 1123 0000 00 000 000000	WILL CO-EARLY DISTR	247,462.42	0.00		247,462.42	0.00	0.00
Fire Prevention & Safety Fund	90 R 1210 0000 00 000 000000	MOBIL HOME TAX	0.00	0.00		0.00	0.00	0.00
Fire Prevention & Safety Fund	90 R 1290 0000 00 000 000000	PAYMENT IN LIEU OF TAXES FIRE SAFETY	0.00	0.00		0.00	0.00	0.00
Fire Prevention & Safety Fund	90 R 1510 0000 00 000 000000	CHECKING INTEREST	0.00	0.00		0.00	0.00	0.00
Fire Prevention & Safety Fund	90 R 1511 0000 00 000 000000	INVESTMENT INTEREST	75,000.00	22,620.73	0.00	-35,423.77	110,423.77	147.23
Fire Prevention & Safety Fund	90 R 1960 0000 00 000 000000	GRUNDY CO ED TIF	0.00	0.00		0.00	0.00	0.00
Fire Prevention & Safety Fund	90 R 1999 0000 00 000 000000	OTHER-LOCAL SOURCES	0.00	0.00		0.00	0.00	0.00
Fire Prevention & Safety Fund	90 R 7210 0000 00 000 000000	PRIN ON BONDS SOLD	0.00	0.00		0.00	0.00	0.00
Fire Prevention & Safety Fund	90 R 7220 0000 00 000 000000	PREMIUM ON BONDS SOLD	0.00	0.00		0.00	0.00	0.00
<b>90 - -----</b>	<b>Fire Prevention &amp; Safety</b>	<b>PREMIUM ON BONDS SOLD</b>	<b>1,020,504.89</b>	<b>22,620.73</b>	<b>0.00</b>	<b>294,372.62</b>	<b>726,132.27</b>	<b>264</b>
<b>Grand Totals:</b>			<b>73,800,295.50</b>	<b>1,883,077.03</b>	<b>0.00</b>	<b>21,373,048.61</b>	<b>52,427,246.89</b>	



CCC Holdings, Inc.  
 18660 Graphics Drive #200  
 Tinley Park, Illinois 60477  
 P: (773) 721-2500

Project: 23-26-1000 District Admin Building Minooka  
 Community HS District 111  
 201 S Wabena Ave  
 Minooka, Illinois 60447

## OAC Weekly Meetings Agenda: Meeting #18

**Meeting Date** Apr 9, 2024 **Meeting Time** 10:00 AM - 10:30 AM Central Time (US & Canada)

**Meeting Location** 201 S. Wabena Ave Minooka, IL 60447

**Overview** We will be holding a weekly meeting for the Minooka Administration Building project.

**Attachments**

### Scheduled Attendees

Name	Company	Phone Number	Email
Lance Beeler	CCC Holdings, Inc.	P: (773) 721-2500 ext. 6573	lbeeler@ccc-chicago.com
Danny Chiavola	CCC Holdings, Inc.	P: (773) 721-2500 ext. 3925	dchiavola@ccc-chicago.com
Lisa Fortin	CCC Holdings, Inc.	P: (773) 721-2500	lfortin@ccc-chicago.com
Dave Hesse	CCC Holdings, Inc.	P: (773) 721-2500	dhesse@ccc-chicago.com
Pete Muschong	CCC Holdings, Inc.	P: (773) 721-2500	pmuschong@ccc-chicago.com
Lou Noto	DLA Architects Ltd		l.noto@dla-ltd.com
Peter Pontarelli	DLA Architects Ltd		p.pontarelli@dla-ltd.com
Kathi Norman	MINOOKA COMMUNITY HIGH SCHOOL		knorman@mchs.net
Jason Piper	MINOOKA COMMUNITY HIGH SCHOOL		jpiper@mchs.net
Rob Schiffbauer	MINOOKA COMMUNITY HIGH SCHOOL		rschiffbauer@mchs.net
Jamie Soliman	MINOOKA COMMUNITY HIGH SCHOOL		jsoliman@mchs.net
John Troy	MINOOKA COMMUNITY HIGH SCHOOL		jtroy@mchs.net
Matt Wikoff	MINOOKA COMMUNITY HIGH SCHOOL		mwikoff@mchs.net

### School Board Meetings

No.	Mtg Origin	Title	Assignment	Due Date	Priority	Status
1.1	1	School Board Meetings				Open
<b>Description</b>						
<ul style="list-style-type: none"> <li>• March 20, 2024</li> <li>• April 17, 2024</li> </ul>						
<b>Previous Meeting Minutes</b>						
<b>Apr 2, 2024</b>						
<ul style="list-style-type: none"> <li>• April 17, 2024</li> </ul>						

<p><b>Mar 26, 2024</b></p> <ul style="list-style-type: none"> <li>• April 17, 2024</li> </ul> <p><b>Mar 19, 2024</b></p> <ul style="list-style-type: none"> <li>• March 20, 2024</li> </ul> <p><b>Mar 12, 2024</b></p> <ul style="list-style-type: none"> <li>• March 20, 2024</li> </ul> <p><b>Mar 5, 2024</b> March 20, 2024 April 17, 2024 May 15, 2024</p>
--

**Safety**

No.	Mtg Origin	Title	Assignment	Due Date	Priority	Status
1.2	1	General Requirements				Open
<p><b>Description</b> Safety Items</p>						
<p><b>Previous Meeting Minutes</b> <b>Apr 2, 2024</b> Ni issues</p>						
<p><b>Mar 26, 2024</b> No issues</p>						
<p><b>Mar 19, 2024</b> Ni issues</p>						
<p><b>Mar 12, 2024</b> (None)</p>						

**School Issues or Concerns**

No.	Mtg Origin	Title	Assignment	Due Date	Priority	Status
1.3	1	Items or Concerns				Open
<p><b>Description</b> District 111 Discussion on Issues or Concerns</p>						
<p><b>Previous Meeting Minutes</b> <b>Apr 2, 2024</b> CCC submitted cost for core swap out to meet the districts request.</p>						
<p><b>Mar 26, 2024</b> CCC is working on a response for the Schlage cores vs. Corbin Russwin cores.</p>						
<p><b>Mar 19, 2024</b> We had our keying schedule conference today. The owners locksmith discovered the submitted and approved Schlage cores need to be the Corbin Russwin 59A1.</p>						

CCC to determine if we can swap the Schlage cores for the Corbin Russwin cores.

**Mar 12, 2024**

No issue

**Schedule**

No.	Mtg Origin	Title	Assignment	Due Date	Priority	Status
1.4	1	Project Schedule	Danny Chiavola (CCC Holdings, Inc.)	Oct 23, 2023	High	Open
<p><b>Description</b> Both the CPM Schedule and 3 week look ahead schedule discussions.</p>						
<p><b>Attachments</b> <a href="#">Minooka_HS_03.01.24.pdf</a></p>						
<p><b>Previous Meeting Minutes</b> <b>Apr 2, 2024</b> Updated schedule meeting to be scheduled</p>						
<p><b>Mar 26, 2024</b> To be updated... CPM is the fire alarm.</p>						
<p><b>Mar 19, 2024</b> Key topics for todays schedule were the fire alarm change order, re-review per the 3rd party reviewer for the Minooka township, fire sprinkler review and procurement of material, trash enclosure change order, fabrication of casework. The mile stone for this work to start is April 8th to complete project by May 3.</p>						
<p><b>Mar 12, 2024</b> To be updated once elevator work commences.</p>						

No.	Mtg Origin	Title	Assignment	Due Date	Priority	Status
1.5	1	Three week Look Ahead				Open
<p><b>Description</b> Attached is the 3 week look ahead</p>						
<p><b>Previous Meeting Minutes</b> <b>Apr 2, 2024</b> see attached</p>						
<p><b>Mar 26, 2024</b> (None)</p>						
<p><b>Mar 19, 2024</b> (None)</p>						
<p><b>Mar 5, 2024</b> see attached</p>						

**Pre-Installation Meetings**

No.	Mtg Origin	Title	Assignment	Due Date	Priority	Status
1.6	1	Required Pre-Installation Meetings				Open
<p><b>Description</b> All Pre-Installation Meeting schedule. Meeting Minutes to be delivered separate from these meeting minutes.</p>						

<p><b>Previous Meeting Minutes</b> <b>Apr 2, 2024</b> None this week</p> <p><b>Mar 26, 2024</b> March 25 Glazing Preinstallation meeting-Completed</p> <p>March 12 RTU pre-installation meeting- Completed</p> <p>Keying Conference next week (TBD) March 11- Completed</p> <p><b>Mar 19, 2024</b> Keying Conference next week (TBD) March 19 Completed</p> <p>March 25 Glazing Preinstallation meeting</p> <p><b>Mar 12, 2024</b> (None)</p> <p><b>Mar 5, 2024</b> March 12 RTU pre-installation meeting</p> <p>Keying Conference next week (TBD) March 11</p> <p>March 19 Glazing Preinstallation meeting</p>
---

**Required Inspections**

No.	Mtg Origin	Title	Assignment	Due Date	Priority	Status
1.7	1	Required Inspections				Open
<p><b>Description</b> Inspection Schedule</p> <p><b>Previous Meeting Minutes</b> <b>Apr 2, 2024</b> Above ceiling two weeks</p> <p><b>Mar 26, 2024</b> IDPH  Health Department</p> <p><b>Mar 19, 2024</b> Nothing scheduled</p> <p><b>Mar 12, 2024</b> (None)</p> <p><b>Mar 5, 2024</b> Nothing scheduled this week.</p>						

**Submittals**

No.	Mtg Origin	Title	Assignment	Due Date	Priority	Status
1.8	1	Submittal Log				Open
<p><b>Description</b> Submittals are on Procore - HOT submittals will be the discussion</p>						

<p><b>Previous Meeting Minutes</b>  <b>Apr 2, 2024</b>                  Wall covering ***HOT***</p> <p><b>Mar 26, 2024</b>                  Carroll Seating to confirm SD for record.</p> <p><b>Mar 19, 2024</b>                  Casework SD ***HOT***</p> <p><b>Mar 12, 2024</b>                  (None)</p> <p><b>Mar 5, 2024</b>                  Casework SD ***HOT***</p> <p>Metal ceiling panels.</p>
--

**Change Orders**

No.	Mtg Origin	Title	Assignment	Due Date	Priority	Status
1.10	1	Change Orders				Open
<b>Description</b>						
Change Order Log attached						
<b>Attachments</b>						
<a href="#">Minooka Allowance Recap log3-26-24.pdf</a>						
<b>Previous Meeting Minutes</b>						
<b>Apr 2, 2024</b>						
See attached						
Some change orders have impacted schedule.						
Elevator interiors						
Fire Alarm						
Fire sprinkler						
<b>Mar 26, 2024</b>						
See attached						
<b>Mar 19, 2024</b>						
See attached						
<b>Feb 6, 2024</b>						
RFP #8 Fire Alarm open						
CCC directed to move forward with elevator pit investigation on T&M.						
<b>Jan 23, 2024</b>						
No open change orders.						
Trash compactor forthcoming.						
<b>Jan 9, 2024</b>						
See attached						

**Pay Application**

No.	Mtg Origin	Title	Assignment	Due Date	Priority	Status
1.11	1	Pay Application Status				Open
<p><b>Description</b> Status of the Pay Application Discussion</p> <p><b>Previous Meeting Minutes</b> <b>Apr 2, 2024</b> Pencil to be submitted this week to review.</p> <p><b>Mar 26, 2024</b> Approved</p> <p><b>Mar 19, 2024</b> Pay application submitted and approved 3/8/24</p> <p><b>Feb 6, 2024</b> To be submitted by 2/9/24</p> <p><b>Jan 23, 2024</b> Pencil due February 5, 2024.</p> <p><b>Jan 9, 2024</b> Submitted January 3, 2024 DLA under review</p>						

**RFI Log**

No.	Mtg Origin	Title	Assignment	Due Date	Priority	Status
1.12	1	Open RFI's				Open
<p><b>Description</b> Discussion on RFI Log</p> <p><b>Attachments</b> <a href="#">RFI LOG 3-26-24.pdf</a></p> <p><b>Previous Meeting Minutes</b> <b>Apr 2, 2024</b> see attached</p> <p><b>Mar 26, 2024</b> see attached</p> <p><b>Mar 19, 2024</b> See attached</p> <p><b>Feb 6, 2024</b> See attached open RFI's</p> <p><b>Jan 23, 2024</b> RFI 23 1st floor lighting cans.  RFI 17 AV heights</p> <p><b>Jan 9, 2024</b> RFI #17 AV locations - OPEN District to review AV heights in field with CCC</p>						

**Open Items**

No.	Mtg Origin	Title	Assignment	Due Date	Priority	Status
13.4	13	Furniture Delivery	Dave Hesse (CCC Holdings, Inc.)	Mar 15, 2024	High	Open
<b>Description</b> Coordination of furniture install						
<b>Previous Meeting Minutes</b> <b>Apr 2, 2024</b> Furniture delivery scheduled for May 15th looks good. To use elevator before the interiors are completed.						
<b>Mar 26, 2024</b> DLA will review contract on delivery						
<b>Mar 19, 2024</b> May 15th schedule delivery by furniture contractor.						

No.	Mtg Origin	Title	Assignment	Due Date	Priority	Status
13.5	13	Dumpster Enclosure Drawings	Peter Pontarelli (DLA Architects Ltd)	Mar 15, 2024	High	Open
<b>Description</b> DLA submitted to city for review.						
<b>Previous Meeting Minutes</b> <b>Apr 2, 2024</b> Cost to be reviewed again by contractors to sharpen pencil for best pricing.						
<b>Mar 26, 2024</b> CCC working on break down of pricing.						
<b>Mar 19, 2024</b> CCC waiting on fencing cost and asphalt						



CCC Holdings, Inc.

Printed on Tue Apr 9, 2024 at 07:28 am CDT  
 Job #: 23-26-1000 District Admin Building Minooka Community HS District 111  
 201 S Wabena Ave  
 Minooka, Illinois 60447

**RFI LOG**

#	Subject	Status	Responsible Contractor	Received From	Assignee	Date Initiated	RFI Manager	Due Date	Closed Date	Ball In Court	Location	Schedule Impact	Cost Code	Cost Impact
34	T'rack in Basement	Open	CSN Electric LLC	Hughes, Phil (CSN Electric LLC)	Pontarelli, Peter...	04/08/2024	Dave Hesse	04/13/2024		Pontarelli, Peter...	Basement	TBD		TBD







**CCC Holdings, Inc.**  
 18660 Graphics Drive #200  
 Tinley Park, Illinois 60477  
 P: (773) 721-2500

**Project: 23-26-1000 District Admin Building Minooka**  
**Community HS District 111**  
 201 S Wabena Ave  
 Minooka, Illinois 60447

## OAC Weekly Meetings Agenda: Meeting #19

**Meeting Date** Apr 16, 2024      **Meeting Time** 10:00 AM - 10:30 AM Central Time (US & Canada)

**Meeting Location** 201 S. Wabena Ave Minooka, IL 60447

**Overview** We will be holding a weekly meeting for the Minooka Administration Building project.

**Attachments**

### Scheduled Attendees

Name	Company	Phone Number	Email
Lance Beeler	CCC Holdings, Inc.	P: (773) 721-2500 ext. 6573	lbeeler@ccc-chicago.com
Danny Chiavola	CCC Holdings, Inc.	P: (773) 721-2500 ext. 3925	dchiavola@ccc-chicago.com
Dave Hesse	CCC Holdings, Inc.	P: (773) 721-2500	dhesse@ccc-chicago.com
Pete Muschong	CCC Holdings, Inc.	P: (773) 721-2500	pmuschong@ccc-chicago.com
Lou Noto	DLA Architects Ltd		l.noto@dla-ltd.com
Peter Pontarelli	DLA Architects Ltd		p.pontarelli@dla-ltd.com
Kathi Norman	MINOOKA COMMUNITY HIGH SCHOOL		knorman@mchs.net
Jason Piper	MINOOKA COMMUNITY HIGH SCHOOL		jpiper@mchs.net
Rob Schiffbauer	MINOOKA COMMUNITY HIGH SCHOOL		rschiffbauer@mchs.net
Jamie Soliman	MINOOKA COMMUNITY HIGH SCHOOL		jsoliman@mchs.net
John Troy	MINOOKA COMMUNITY HIGH SCHOOL		jtroy@mchs.net
Matt Wikoff	MINOOKA COMMUNITY HIGH SCHOOL		mwikoff@mchs.net

### School Board Meetings

No.	Mtg Origin	Title	Assignment	Due Date	Priority	Status
1.1	1	School Board Meetings				Open
<b>Description</b>						
<ul style="list-style-type: none"> <li>• March 20, 2024</li> <li>• April 17, 2024</li> </ul>						
<b>Previous Meeting Minutes</b>						
<b>Apr 9, 2024</b>						
<ul style="list-style-type: none"> <li>• April 17, 2024</li> </ul>						

<p><b>Apr 2, 2024</b></p> <ul style="list-style-type: none"> <li>• April 17, 2024</li> </ul> <p><b>Mar 26, 2024</b></p> <ul style="list-style-type: none"> <li>• April 17, 2024</li> </ul> <p><b>Mar 12, 2024</b></p> <ul style="list-style-type: none"> <li>• March 20, 2024</li> </ul> <p><b>Mar 5, 2024</b>                  March 20, 2024                  April 17, 2024                  May 15, 2024</p>
--

**Safety**

No.	Mtg Origin	Title	Assignment	Due Date	Priority	Status
1.2	1	General Requirements				Open
<p><b>Description</b> Safety Items</p>						
<p><b>Previous Meeting Minutes</b></p> <p><b>Apr 9, 2024</b> No issues</p> <p><b>Apr 2, 2024</b> Ni issues</p> <p><b>Mar 26, 2024</b> No issues</p> <p><b>Mar 12, 2024</b> (None)</p>						

**School Issues or Concerns**

No.	Mtg Origin	Title	Assignment	Due Date	Priority	Status
1.3	1	Items or Concerns				Open
<p><b>Description</b> District 111 Discussion on Issues or Concerns</p>						
<p><b>Previous Meeting Minutes</b></p> <p><b>Apr 9, 2024</b> No issues</p> <p><b>Apr 2, 2024</b> CCC submitted cost for core swap out to meet the districts request.</p> <p><b>Mar 26, 2024</b> CCC is working on a response for the Schlage cores vs. Corbin Russwin cores.</p>						

Mar 12, 2024  
No issue

**Schedule**

No.	Mtg Origin	Title	Assignment	Due Date	Priority	Status
1.4	1	Project Schedule	Danny Chiavola (CCC Holdings, Inc.)	Oct 23, 2023	High	Open
<p><b>Description</b> Both the CPM Schedule and 3 week look ahead schedule discussions.</p> <p><b>Attachments</b> <a href="#">Minooka_HS_03.01.24.pdf</a></p> <p><b>Previous Meeting Minutes</b>  <b>Apr 9, 2024</b> Updated overall schedule will be issued next week.   <b>Apr 2, 2024</b> Updated schedule meeting to be scheduled   <b>Mar 26, 2024</b> To be updated... CPM is the fire alarm.   <b>Mar 12, 2024</b> To be updated once elevator work commences.</p>						

No.	Mtg Origin	Title	Assignment	Due Date	Priority	Status
1.5	1	Three week Look Ahead				Open
<p><b>Description</b> Attached is the 3 week look ahead</p> <p><b>Attachments</b> <a href="#">Copy of 3 WEEK LOOK AHEAD Minooka 4_8_24 .xls</a></p> <p><b>Previous Meeting Minutes</b>  <b>Apr 9, 2024</b> see attached.   <b>Apr 2, 2024</b> see attached   <b>Mar 26, 2024</b> (None)   <b>Mar 5, 2024</b> see attached</p>						

**Pre-Installation Meetings**

**Required Inspections**

No.	Mtg Origin	Title	Assignment	Due Date	Priority	Status
1.7	1	Required Inspections				Open
<b>Description</b> Inspection Schedule						
<b>Previous Meeting Minutes</b> <b>Apr 9, 2024</b> Above ceiling inspection scheduled for this Friday 4/12/24						
<b>Apr 2, 2024</b> Above ceiling two weeks						
<b>Mar 26, 2024</b> IDPH						
Health Department ( Look at permit ) ↳ Everything done, thermometers in fridge						
<b>Mar 12, 2024</b> (None)						
<b>Mar 5, 2024</b> Nothing scheduled this week.						

**Submittals**

No.	Mtg Origin	Title	Assignment	Due Date	Priority	Status
1.8	1	Submittal Log				Open
<b>Description</b> Submittals are on Procore - HOT submittals will be the discussion						
<b>Previous Meeting Minutes</b> <b>Apr 9, 2024</b> Wall covering ***HOT***						
<b>Apr 2, 2024</b> Wall covering ***HOT***						
<b>Mar 26, 2024</b> Carroll Seating to confirm SD for record.						
<b>Mar 12, 2024</b> (None)						
<b>Mar 5, 2024</b> Casework SD ***HOT***						
Metal ceiling panels.						

**Change Orders**

No.	Mtg Origin	Title	Assignment	Due Date	Priority	Status
1.10	1	Change Orders				Open
<b>Description</b> Change Order Log attached						

**Attachments**

[Minooka Allowance Recap log 4.8.24.pdf](#)

**Previous Meeting Minutes**

**Apr 9, 2024**

See attached

**Apr 2, 2024**

See attached

Some change orders have impacted schedule.

Elevator interiors

Fire Alarm

Fire sprinkler

**Mar 26, 2024**

See attached

**Feb 6, 2024**

RFP #8 Fire Alarm open

CCC directed to move forward with elevator pit investigation on T&M.

**Jan 23, 2024**

No open change orders.

Trash compactor forthcoming.

*dumpster*

**Jan 9, 2024**

See attached

**Pay Application**

No.	Mtg Origin	Title	Assignment	Due Date	Priority	Status
1.11	1	Pay Application Status				Open
<b>Description</b>						
Status of the Pay Application Discussion						
<b>Previous Meeting Minutes</b>						
<b>Apr 9, 2024</b>						
Pencil review, adjusted change order view.						
<b>Apr 2, 2024</b>						
Pencil to be submitted this week to review.						
<b>Mar 26, 2024</b>						
Approved						
<b>Feb 6, 2024</b>						
To be submitted by 2/9/24						
<b>Jan 23, 2024</b>						
Pencil due February 5, 2024.						
<b>Jan 9, 2024</b>						
Submitted January 3, 2024 DLA under review						

**RFI Log**

No.	Mtg Origin	Title	Assignment	Due Date	Priority	Status
1.12	1	Open RFI's				Open
<p><b>Description</b> Discussion on RFI Log</p>						
<p><b>Attachments</b> <a href="#">RFI LOG 3-26-24.pdf</a></p>						
<p><b>Previous Meeting Minutes</b> <b>Apr 9, 2024</b> RFI #35: Finish at Exposed Beam &amp; Columns</p>						
<p><b>Apr 2, 2024</b> see attached</p>						
<p><b>Mar 26, 2024</b> see attached</p>						
<p><b>Feb 6, 2024</b> See attached open RFI's</p>						
<p><b>Jan 23, 2024</b> RFI 23 1st floor lighting cans.  RFI 17 AV heights</p>						
<p><b>Jan 9, 2024</b> RFI #17 AV locations - OPEN District to review AV heights in field with CCC</p>						

**Open Items**

No.	Mtg Origin	Title	Assignment	Due Date	Priority	Status
13.4	13	Furniture Delivery	Dave Hesse (CCC Holdings, Inc.)	Mar 15, 2024	High	Open
<p><b>Description</b> Coordination of furniture install</p>						
<p><b>Previous Meeting Minutes</b> <b>Apr 9, 2024</b> Rescheduled for June 6 2024</p>						
<p><b>Apr 2, 2024</b> Furniture delivery scheduled for May 15th looks good. To use elevator before the interiors are completed.</p>						
<p><b>Mar 26, 2024</b> DLA will review contract on delivery</p>						

No.	Mtg Origin	Title	Assignment	Due Date	Priority	Status
13.5	13	Dumpster Enclosure Drawings	Peter Pontarelli (DLA Architects Ltd)	Mar 15, 2024	High	Open
<p><b>Description</b> DLA submitted to city for review.</p>						

**Previous Meeting Minutes**

**Apr 9, 2024**

Pricing maybe be out of budget. District to notify CCC of status after meeting.

**Apr 2, 2024**

Cost to be reviewed again by contractors to sharpen pencil for best pricing.

**Mar 26, 2024**

CCC working on break down of pricing.





CCC Holdings, Inc.

Job #: 23-26-1000 District Admin Building Minooka Community HS District 111  
 201 S Wabena Ave  
 Minooka, Illinois 60447

Printed on Tue Apr 16, 2024 at 06:32 am CDT

## RFI LOG

#	Subject	Status	Responsible Contractor	Received From	Assignee	Date Initiated	RFI Manager	Due Date	Closed Date	Ball In Court	Location	Schedule Impact	Cost Code	Cost Impact
35	Finish at Exposed Beam & Columns	Open		None	Portarelli, Peter...	04/11/2024	Danny Chivova	04/15/2024		Portarelli, Peter...	1st floor			



## Minooka HS Admin Building Dist 111

Name of Project	PERI 04/15/24 to ###																															
Minooka HS Admin Build	Projected Schedule																															
	4/16/2024																															
March	1				2				3				4																			
WEEK #	M	T	W	T	F	S	M	T	W	T	F	S	M	T	W	T	F	S	M	T	W	T	F	S	M	T	W	T	F	S		
DESCRIPTION OF WORK	15	16	17	18	19	20	21	22	23	24	25	26	27	28	29	30	01	02	03	04	05	06	07	08	09	10	11	12	13	14	15	
Lighting install 1st floor																																
Lighting install 2nd floor																																
Water Heater Install																																

### **The District #111 Foundation for Educational Excellence**

The foundation held a meeting on April 9, 2024. The foundation accepted the resignations of Chris Papesh and Katie Uphoff. The foundation would like to thank Chris and Katie for their service on the foundation. The foundation discussed future fundraising events and membership. The next Foundation for Educational Excellence meeting is Thursday, June 13, 2024. The Foundation is currently accepting grant applications.

---

# Facilities Plan





---

# Input from Stakeholders

- Faculty
- Students
- Parents
- Community members



---

# Facilities Plan

## Two Phases

- **Phase 1**
  - Central Campus Industrial Technology addition
  - South Campus Fieldhouse addition
- **Phase 2**
  - South Campus Performing Arts Center
  - South Campus Pool
  - Central Campus classroom remodel
  - Central Campus classroom addition
  - Central Campus general remodeling



# Phase I: Central Campus Industrial Technology Addition

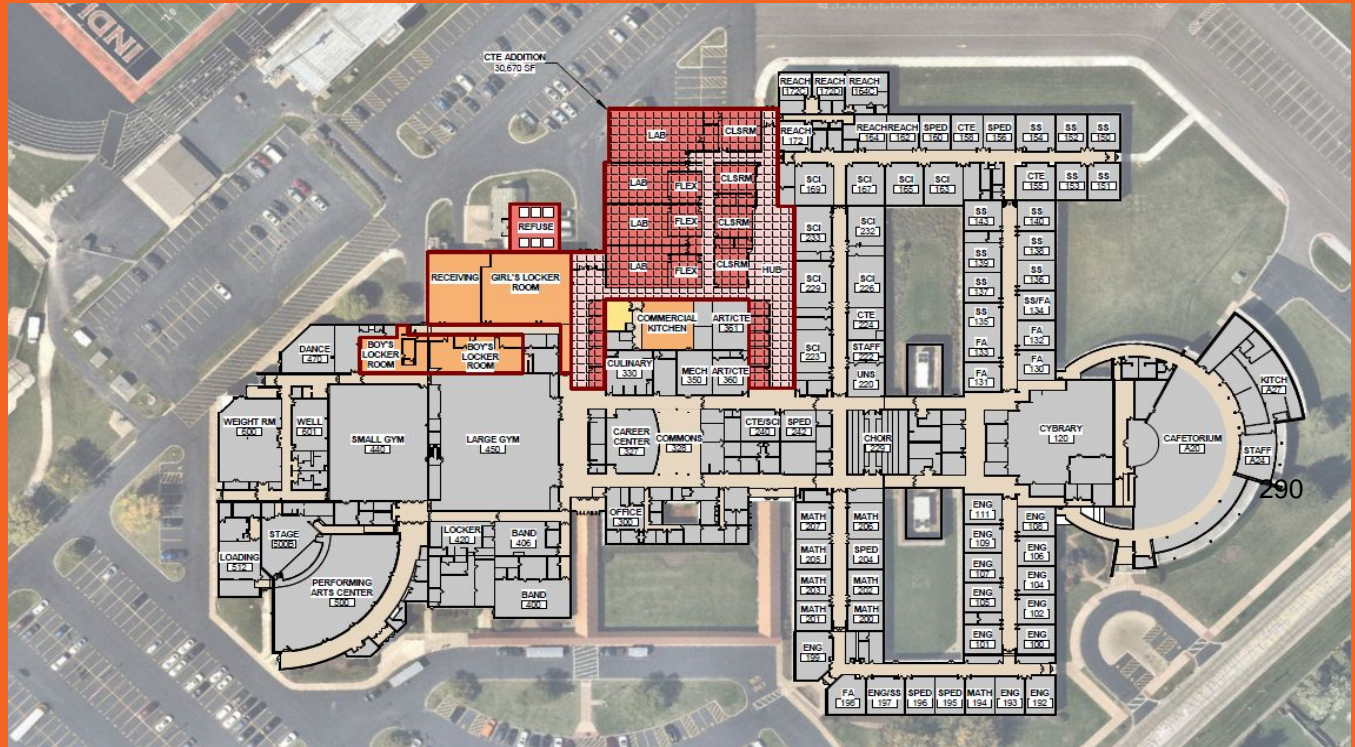

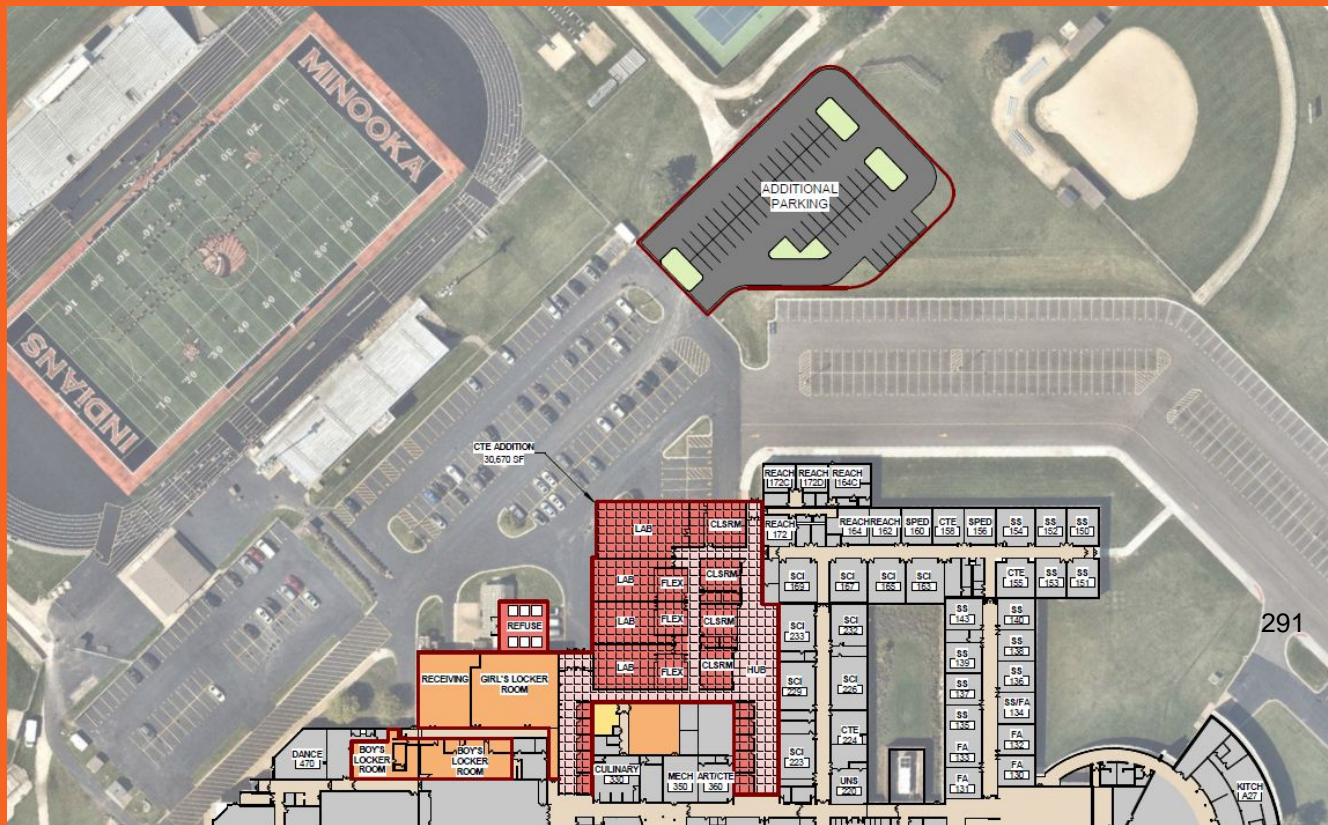



---

## Why an Industrial Technology addition?

- Current facilities are undersized
- Current facilities have not seen significant upgrades since their construction over 50 years ago
- GVAC is unable, in its current configuration, to accommodate all of the MCHS students who wish to pursue Industrial Technology
- Transportation to GAVC



# South Campus Fieldhouse Addition

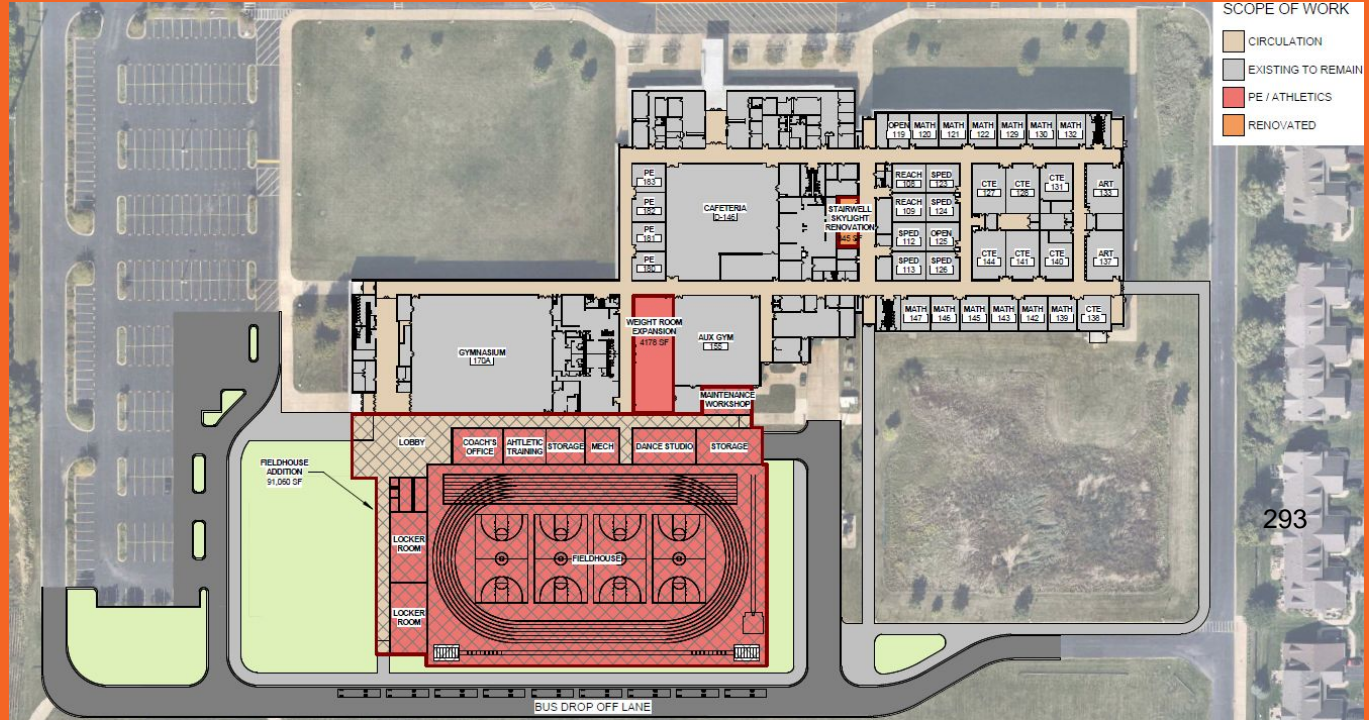

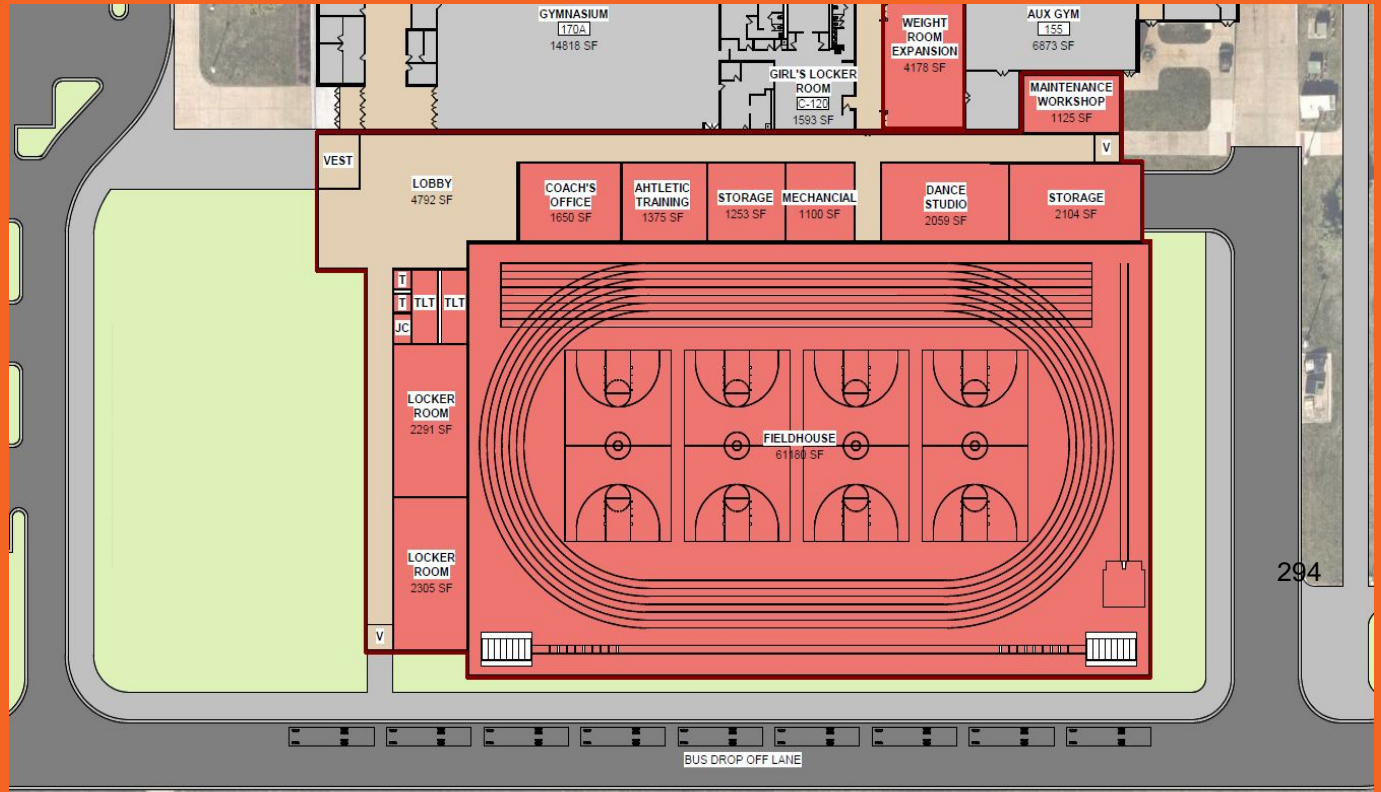



---

## Why a Field House at South Campus?

- Physical Education is out of space for classes
- Physical Education is out of locker room space to accommodate all students
- There is not enough space to accommodate the practice/competition needs of athletic teams
- Would allow MCHS to add Badminton to our athletic offerings for girls
- Would be an asset for the community to utilize for various purposes



---

## Financing Phase I

- \$20 million in current fund balances
- \$27 million can be borrowed through working cash bonds
- \$30 million can be borrowed through the use of debt certificates

**\$77 million available**



---

# Timeline for Phase I finances

## Debt Certificates

- September 2024: Due diligence review
- October 2024: Board approves resolution and signs final term sheet for debt certificates.
- October 2024: District closes on debt certificates.

## Working Cash Bonds

- November 2024: Board approves resolution of intent to issue Working Cash and Funding Bonds.
- December 2024: Board holds a Bond Issue Notification Public Hearing.
- January 2025: Board approves the sales resolution and signs<sup>297</sup> bond purchase agreement.
- February 2025: Closing on the bonds.



# Current Tax Rate Will Be Maintained

Fund	2016	2017	2018	2019	2020	2021	2022	Estimated 2023 Rate
Education	\$1.22	\$1.22	\$1.22	\$1.22	\$1.20	\$1.22	\$1.22	\$1.2200
Bonds and Interest	0.72259	0.68887	0.60912	0.55914	0.5213	0.4804	0.45887	\$0.4191
Operations and Maintenance	0.25	0.25	0.25	0.25	0.25	0.25	0.25	\$0.2500
IMRF	0.03043	0.02905	0.02892	0.02668	0.02519	0.0236	0.0242	\$0.0245
Transportation	0.12	0.12	0.12	0.12	0.12	0.12	0.12	\$0.1200
Special Education	0.02	0.02	0.02	0.02	0.02	0.02	0.02	\$0.0200
Tort Liability	0.09735	0.09295	0.08389	0.0774	0.07218	0.0675	0.07711	\$0.0735
Social Security/Medicare	0.03854	0.0368	0.03606	0.03327	0.03133	0.0295	0.02925	\$0.0294
Lease	0.05	0.05	0.05	0.03294	0.03133	0.0295	0.02925	\$0.0294
Working Cash	0.05	0.05	0.05	0.05	0.05	0.05	0.05	298 \$0.0500
Fire Prevention/Safety	0.05	0.05	0.05	0.05	0.05	0.05	0.05	\$0.0500
<b>Total District Tax Rate</b>	<b>\$2.65</b>	<b>\$2.61</b>	<b>\$2.52</b>	<b>\$2.44</b>	<b>\$2.37</b>	<b>\$2.34</b>	<b>\$2.33</b>	<b>\$2.286</b>



# Phase II Central Campus

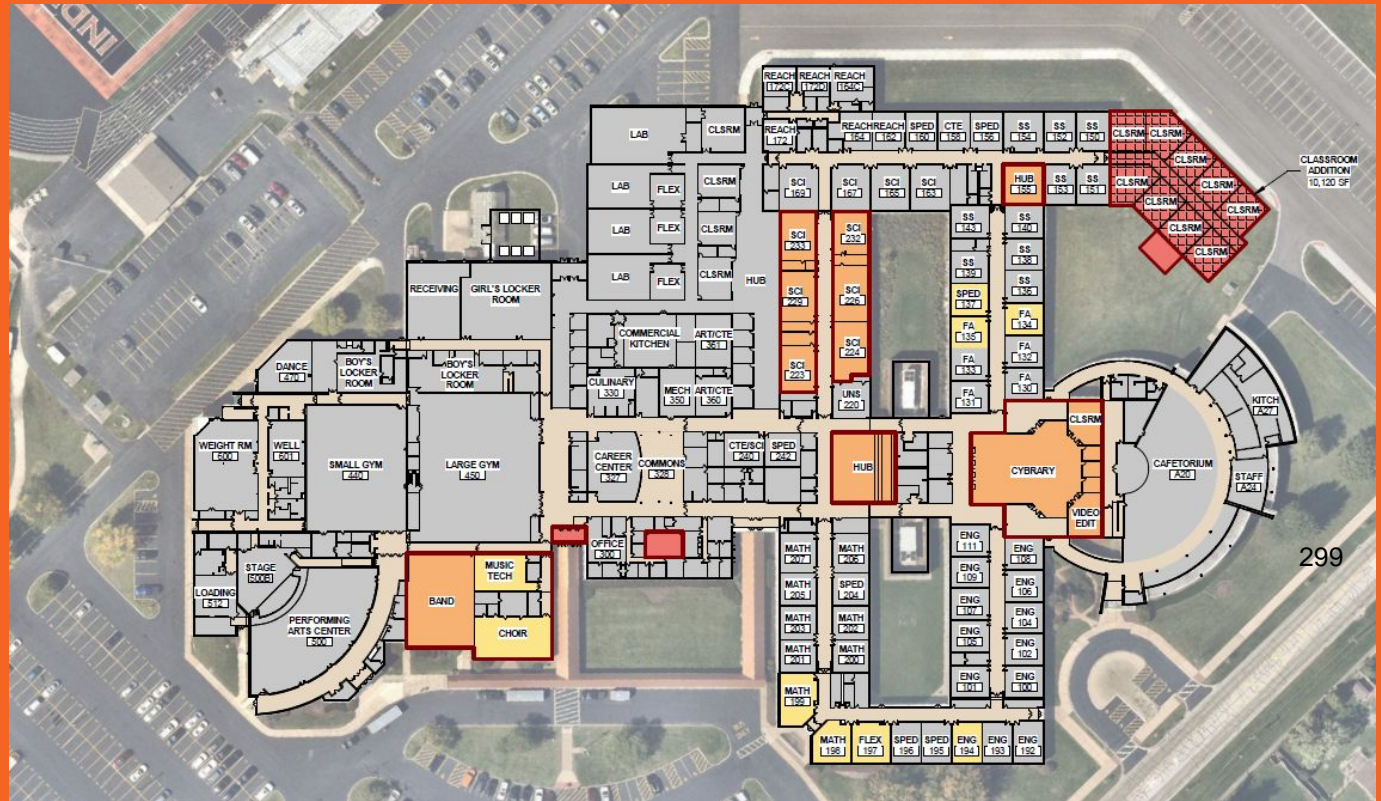



# Phase II South Campus

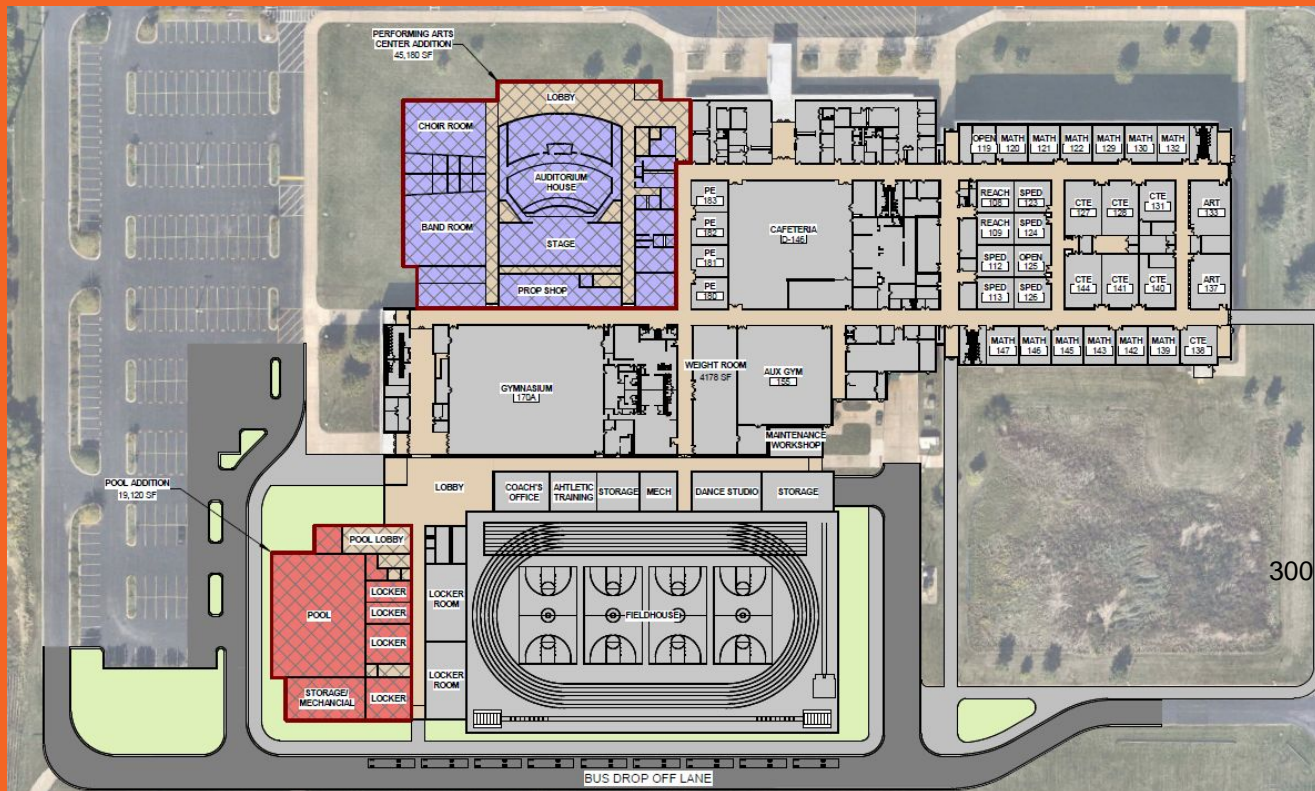



---

## Phase II Financing

- Referendum

Or

- Working Cash Bonds/Debt Certificates



---

## Next steps...

- Hire a construction manager
- Authorize DLA to begin designing the project
- Authorize Stifel Financial to begin preparing for the financing of the project
- Launch web page that details the project

## Proposal: PC6497

DePue Mechanical, Inc.  
PO Box 857  
Minooka, IL 60447



Revision: 0

# Minooka Community High School South Campus - Cooling Tower Replacement



**MINOOKA**  
COMMUNITY HIGH SCHOOL

### Customer:

Minooka Community High School South Campus  
26655 W. Eames St  
Channahon, IL 60410

**Valid Until: 4/30/2024**

# Proposal: PC6497

DePue Mechanical, Inc.  
PO Box 857  
Minooka, IL 60447



---

## Investment Summary

We herewith submit our proposal to furnish all necessary labor, supervision, materials, tools, equipment, and consumables to complete the scope of work as described below and in the Invitation to bid sent via email on April 2, 2024, Addendum 1 sent via email on April 8, 2024 and the Jobsite Walk on February 9, 2024

The below mentioned scope of work can be completed for the firm, Lump Sum Investment of:

**Three Hundred Eighty Two Thousand Seven Hundred Sixty Eight Dollars and Zero Cents:**

**(\$382,768.00)**

---

## Scope of Work

### Mechanical:

- Disconnect of existing cooling tower piping
- Demo and removal of existing cooling tower
- Furnish and install of One (1) new 2 cell cooling tower (Please see attached Cooling Tower Specs for reference)
- Installation of shipped loose items for cooling tower (i.e. handrail, fan guards, etc.)
- Fabrication and installation of approximately 100 ft of 8" CS Sch. 40 pipe with grooved ends
- Fabricate and install approximately 60 ft of 6" CS Sch. 40 pipe with grooved ends
- Fabricate and install approximately 20 ft of 10" CS Sch. 40 pipe with grooved ends
- Furnish and install all required new vic clamps with gaskets (water service)
- Furnish and install 10" equalization line including drain valve
- Furnish and install water make up line using pro-press copper
- Furnish and install overflow drain using PVC schedule 40

### Electrical:

- Demolition of conduits & wiring supported to existing tower
- Cooling tower motor disconnects
- Pull wire & cable back to junction boxes located inside building
- Two (2) new NEMA 3R 60amp disconnects
- Two (2) motor disconnects
- Six (6) instrument connections
- All new rigid conduit, fittings & wire

# Proposal: PC6497

DePue Mechanical, Inc.  
PO Box 857  
Minooka, IL 60447



- All terminations, testing & labels
- Background Checks
- Commissioning assistance (8 hours)

## Painting:

- All Carbon Steel pipe to be wired brushed and solvent wiped clean
- Roller apply one (1) coat of PPG's Amerlock 2 epoxy and two coats of PPG's durethane
- All painting to be completed in the field after installation of piping

## Exclusions, Assumptions, Clarifications

### General

1. Pipe System - Cleaning or Flushing is not included
2. Disassembly or Reassembly of any equipment furnished by Owner/Others - unless specifically identified in DePue Scope-of-Work.
3. Furnishing of glycol, freon, or refrigerant is excluded
4. Site Temporary Dumpsters, Port-o-Lets, Power (Power to be made available to DePue at no charge), and Office or Lunch Space to be provided by owner/other
5. No relocation of existing piping or systems to accommodate work - unless specifically identified in DePue Scope-of-Work.
6. Furnishing of Temporary Heating or Cooling is not included
7. Roof Penetrations are not included
8. Motor Starters, Disconnects, VFD are excluded (N.I.S.) unless specifically indicated otherwise in the scope-of-work section of DePue Proposal.
9. Winter and Weather Protection - excluded (N.I.S)
10. Furnishing or Installation of Roof Curbs is not included - DePue to set new towers on existing roof steel supports
11. Piping System - Identification, Labels and/or Valve Markers & Tags/ID are not included
12. ADDER OPTION: The SPX Cooling Tech, LLC Certification of Limited Warranty ("Warranty Certificate") shall include a 5 year labor warranty. All other terms of the Warranty Certificate remain unchanged and in effect. Please ADD \$13,490.00 if required
13. Additional service calls after start-up, including diagnostic issues - billed hourly as needed
14. DePue Mechanical Requires a 15% down payment at time of Purchase Order
15. Current Product Lead time of Cooling Tower (from date of written release to shipment from factory) is approximately 25 weeks
16. Please note there will be a material price increase of the cooling tower of 4% if not released by March 22, 2024
17. ADDER OPTION: Furnish (2) VFD 20 HP 3/50/60 480 NEMA 1 indoor painted steel enclosure ABB ACH580 w/ options NFD + E-Clipse bypass. Demo of existing and re hook up of new. If new VFD's are required Please ADD \$11,950.00 if required
18. Please see attached EXHIBIT B for existing cooling tower catalog

### Subcontractors

1. Furnishing of scaffolding of any kind is excluded (N.I.S.) unless specifically indicated otherwise in the scope-of-work section of DePue Proposal.
2. No Fire Protection work of any kind has been included in Proposal
3. No Structural Steel work of any kind has been Included in Proposal
4. No Roofing work of any kind has been Included in Proposal
5. Fire alarms, exterior lighting, Instruments, Instrument calibrating or bench testing, BAS Terminations are not included in proposal

# Proposal: PC6497

DePue Mechanical, Inc.  
PO Box 857  
Minooka, IL 60447



6. Insulation of make up water only has been included

## Labor

1. Start-up Assistance and/or Standby Assistance except as specifically included under Scope-of-Work (the services can be furnished on a Time and Material basis at additional cost to the contract.)
2. Premium, Overtime and/or Shift Work to Meet Schedule - excluded (N.I.S.)

## Finanical

1. Performance Bond has been included in proposal pricing
2. State Sales and Use Tax. If work is to be tax exempt - Owner to furnish appropriate documentation to support, evidence that project/Owner facility is "Tax Exempt."
3. Permit Fees & Permitting Assistance by Owner/Others
4. Bid Bond EXHIBIT C attached

## Materials

1. Due to the current Volatility of the Market, All Material Pricing will need to be Re-quoted once Depue Mechanical has been Awarded the Project Additional Cost may be Added to the Project.

## QA/QC

1. NDE (Radiography, dye penetrant, ultrasonic, etc.) is not included in this proposal. All piping to be in service tested

## Engineering

1. Floor or Wall Scanning, X-raying of any type is not Included in Proposal
2. Seismic Bracing of any kind - work or calculations are not included
3. Furnish of Coordination Drawings is not Included in Proposal
4. Furnishing of CAD As-Built Drawings (other than manual marked-up 'red-line')
5. Engineering and Professional Design Services are excluded (N.I.S.) unless specifically indicated otherwise.
6. Stamped drawings by Licensed Professional Engineers

## Safety

1. LOTO, isolation and making lines safe for tie-ins to be performed by Owner with coordination by Depue Mechanical
2. Roof and/or Building Fall Protection and Access Engineering Controls and/or Other Controls are - excluded (N.I.S) and to be furnished Owner/Others as required.

## Thank you !!

Mr. Troy, Thank you for the opportunity to provide you with a proposal for this work! Please, anything you need, just let us know. We take a lot of pride in our long-term relationships with client-friends just like you and not only constructing projects but engaging as a resource in the project budgeting and design-development stages as well to ensure maximum project success.

DePue Mechanical is very eager to start this project with you !

If there are any questions in regard to our proposal, please let me know! You can call me anytime on my cell phone (815) 514-0103.

## Proposal: PC6497

DePue Mechanical, Inc.  
PO Box 857  
Minooka, IL 60447



Thank you Mr. Troy!

Very Respectfully,

**Niko Capodice**

niko.capodice@depuemechanical.com

(815) 514-0103 (cell)

(815) 255-2500 (office)

26655 W. Eames Street  
Channahon, IL 60410

# Assurances and Certifications

## PART 1

### STATEMENT OF ETHICS CERTIFICATION

By submission of this bid or proposal, the bidder certifies that:

1. This bid or proposal has been independently arrived at without collusion with any other bidder or with any competitor.
2. This bid or proposal has not been knowingly disclosed and will not be knowingly disclosed, prior to the opening of bids or proposals for this project, to any other bidder, competitor or potential competitor.
3. No attempt has been made or will be made to induce any other person, partnership or corporation to submit or not to submit a bid or proposal.
4. Bidder has not been convicted of price fixing nor pleaded "no contest" to such charges within the last five (5) years.
5. Bidder is not subsidiary of a company that has been convicted of price fixing nor pleaded "no contest" to such charges within the last five (5) years.

By:   
Authorized Agent

SUBSCRIBED and SWORN TO before me

this 11 day of April, 2024

  
NOTARY PUBLIC



This page must be returned signed and notarized for the bid to be considered.

**Minooka Community High School District 111**

26655 W. Eames Street  
Channahon, IL 60410

## Assurances and Certifications PART 2

### SUPPLIER'S/CONTRACTOR'S CERTIFICATION

As part of its bid, the supplier/contractor does hereby certify that said supplier/contractor is not barred from bidding on the contract as a result of violation of either Section 33E-3 or 33E-4 of Article 33E of Chapter 38 of the Illinois Revised Statutes.

By:   
Authorized Agent

### CERTIFICATE OF COMPLIANCE WITH ILLINOIS DRUG-FREE WORKPLACE ACT (Suppliers/Contractors with 25 or More Employees)

As part of its bid, the supplier/contractor does hereby certify pursuant to section 3 of the *Illinois Drug-Free Workplace Act* (Ill.Rev.Stat. ch 127. para. 132.313) that [he, she, it] shall provide a drug-free workplace for all employees engaged in the performance or work under the contract by complying with the requirements of the *Illinois Drug-Free Workplace Act* and, further certifies, that [he, she, it] is not ineligible for award of this contract by reason of debarment for a violation of the *Illinois Drug-Free Workplace Act*.

By:   
Authorized Agent

Does Not Apply (Less than 25 Employees)

By: \_\_\_\_\_  
Authorized Agent

SUBSCRIBED and SWORN TO before me

this 11 day of April, 2024

  
NOTARY PUBLIC

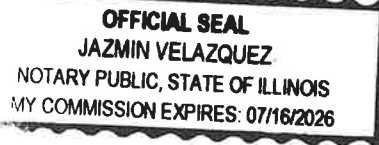

This page must be returned signed and notarized for the bid to be considered.

Minooka Community High School District 111  
26655 W. Eames Street  
Channahon, IL 60410  
**Assurances and Certifications**  
**PART 3**

CERTIFICATE OF COMPLIANCE WITH ILLINOIS HUMAN RIGHTS ACT

Sexual Harassment Policies

As part of its bid, the supplier/contractor does hereby certify pursuant to 775 ILCS 5/2-105 that [he, she, it] has written sexual harassment policies that include at least the minimum information as required by law; that a copy of the policies shall be provided to the Department of Human Rights upon request; and that [he, she, it] is not ineligible for award of this contract by reason of debarment for a violation of the *Illinois Human Rights Act*.

By:   
Authorized Agent

Equal Employment Opportunity

As part of its bid, the supplier/contractor does hereby certify pursuant to 775 ILCS 5/2-104 that [he, she, it] complies with the procedures and requirement of the Illinois Department of Human Rights regulations concerning equal employment opportunities and affirmative action, shall provide such information with respect to its employees and applicants for employment and assistance as the Department may reasonably request, and that [he, she, it] is not ineligible for award of this contract by reason of debarment for a violation of the *Illinois Human Rights Act*.

By:   
Authorized Agent

SUBSCRIBED and SWORN TO before me

this 11 day of April, 2021

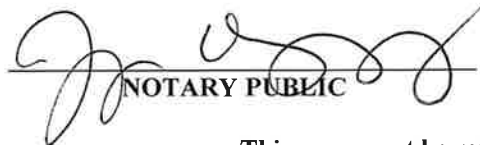
  
NOTARY PUBLIC



This page must be returned signed and notarized for the bid to be considered.

Minooka Community High School District 111  
26655 W. Eames Street  
Channahon, IL 60410

## Assurances and Certifications PART 4

### AGREEMENT TO BE BOUND BY THE TERMS OF THE BID

If the contract is awarded to the contractor, the contractor hereby adopts, accepts, and agrees to be bound by all the terms and conditions of the MINOOKA COMMUNITY HIGH SCHOOL DISTRICT 111 WATER COOLING TOWER REPLACEMENT bid.

By:   
Authorized Agent

### Equal Employment Opportunity

SUBSCRIBED and SWORN TO before me

this 11 day of April, 2024

  
NOTARY PUBLIC



This page must be returned signed and notarized for the bid to be considered.

# EXHIBIT A





**WINDY CITY REPRESENTATIVES  
ENGINEERED SYSTEMS**

**Subject: Minooka HS CT Replacement  
Existing S/N 818648  
SD 111 RFP for Cooling Tower Replacement**

**Terms:** F.O.B. Factory, Freight Allowed and Prepaid, Progress Payments: 30% at Time of Order and 70% at Time of Shipment, Net 30 Day Terms, Taxes NOT Included, Quote Valid for 30 Days

**ITEM I  
COOLING TOWER**

TOWER MODEL	PERFORMANCE CONDITIONS	MOTOR DATA	TOWER DIMENSIONS	WEIGHTS
Quantity of (1) Marley NC Class model <b>NC8405QAN</b> factory assembled 2-Cell crossflow cooling tower	Per 2-cell tower: 2,400 gpm 95.0 °F Hot Water 85.0 °F Cold Water 78.0 °F Entering WB	NEMA 20 HP 1 speed / 1 wind 3 phase / 60 Hz / <b>230/460v</b> 1.15sf / TEFC 1800 RPM Premium Efficiency Inverter duty nameplated <i>Site Voltage: 480</i>	Each cell: (without options) Length 9' - 10 3/4" Width 19' - 11" Height 11' - 11 3/4" Per 2-cell tower: (with options) Length 20' - 9 15/16" Width 19' - 11" Height 15' - 0 7/8"	Per cell: Shipping: 9,352 lb Operating: 20,148 lb Per 2-cell tower: Shipping: 18,704 lb Operating: 40,296 lb

*Quantities shown below are per tower.*

**Base Tower Construction/Equipment:**

- Stainless Steel casing.
- Stainless Steel structure.
- Stainless Steel (per SS Grade) collection basin.
- Stainless Steel (per SS Grade) distribution basin.
- All stainless steel is series 300.
- Custom anchorage design to fit customer's grillage at 220.50 in spacing.
- Low Sound fan with aluminum blades.
- Marley designed Geareducer® with 5-year warranty.
- PVC film fill with integral louvers and drift eliminators designed and manufactured by Marley.
- Published sound data is independently verified by a CTI licensed test agency.
- CTI certification per STD-201.
- 12 in fan cylinder extension.
- HDG steel fan guard.

**Collection Basin Connections and Accessories:**

- All flanges are to Class 125 ANSI B16.1 standard.
- All threads are to American Standard Pipe Taper Thread.
- (2) 8 in (203 mm) diameter bevel and groove cased face outlet(s) with trash screen(s).
- 10 in (254 mm) diameter hole and bolt circle(s) for equalization, One per Cell
- 4 in (102 mm) diameter combination drain and overflow in each cell
- (2) 1 in (25.4 mm) water make-up float valve(s)
- Probe type electronic water level sensor, in cells with outlets, with the following events: make-up, low-alarm, high-alarm

**Distribution Basin Inlet and Accessories:**

- (2) 6 in (152 mm) diameter top inlet connections per cell.
- (2) 6 in (152 mm) horizontal flow control valves per cell.
- Variable flow nozzles.

**Maintenance & Maintenance Access Features:**

- Tower is designed in accordance with OSHA safety standards.

This quotation does not include features which are available to allow safe access on the fan deck while the fan is still operating. If this is a desired feature for your intended operation, please contact your sales representative.

Convenient access to the collection basin and plenum area is provided via a large access door located on each endwall

Easy fitting perimeter guardrail, kneerail & toeboard

(1) Cased face ladder

Ladders extended 60 in below base of tower

Easy fitting ladder safety cage(s)

**Control Systems:**

(1) IMI 685A Mechanical sw, DPDT, manual reset + 30' cord vibration cutoff switch per cell

**Warranty:**

5 year parts-only warranty included standard with SS constructed tower

**Freight:**

Included

ITEMS NOT INCLUDED

- Installation, owner training or commissioning/supervision
- Labor warranty or extended warranties not mentioned above
- Additional service calls after start-up, including diagnostic issues - billed hourly as needed
- Items not mentioned above

Current product lead time (from date of written release to shipment from factory):

23-24 weeks

# EXHIBIT B

# TOWER SCHEMATIC

NC8301 NC8302 NC8303 NC8304 **NC8305** NC8306

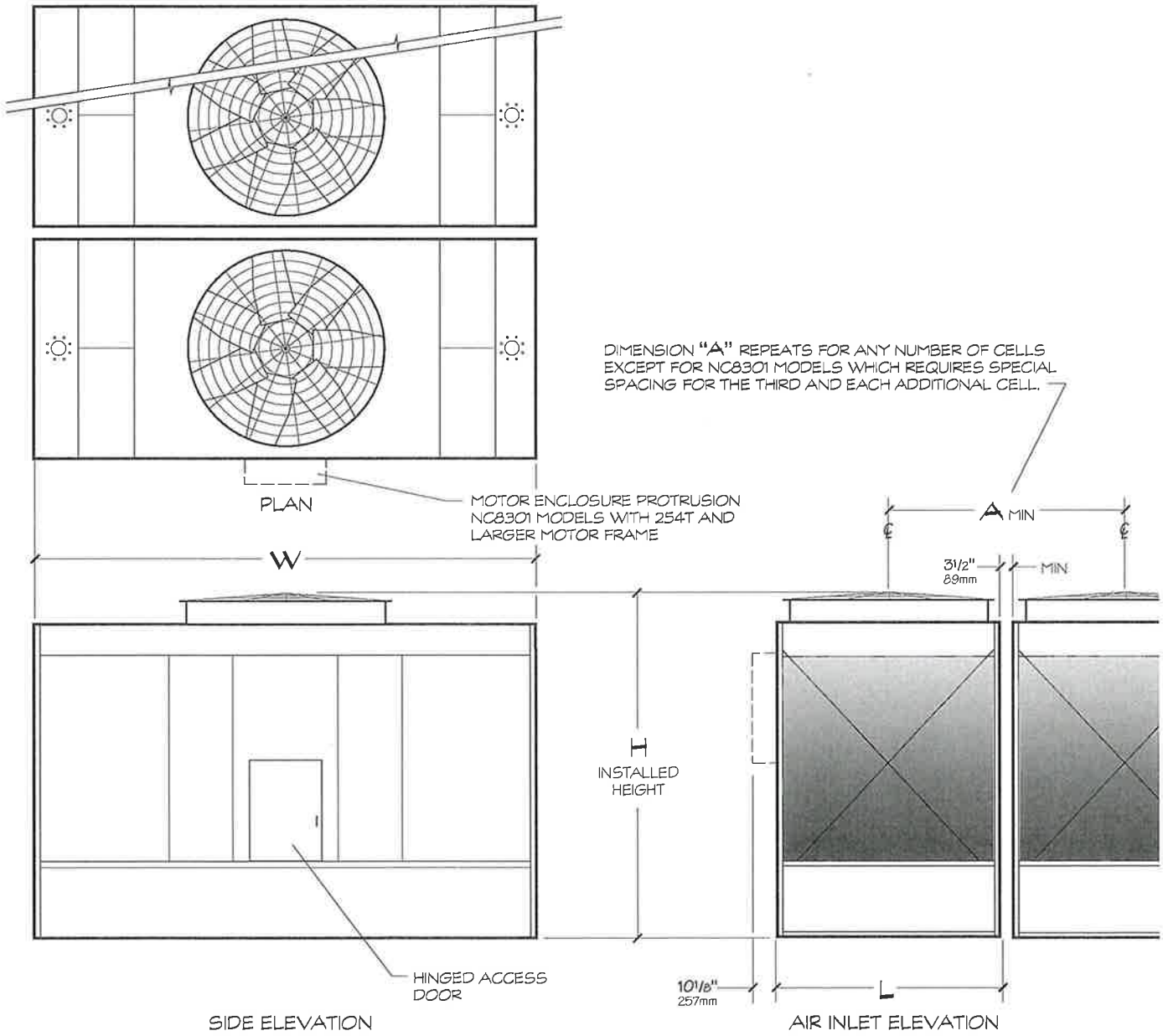

Tower Model Note 2	Nominal Tons Note 3	Motor hp	dBA 5'-0" from air inlet face	Design Operating Wt/Cell lb	Shipping Weight lb	DIMENSIONS			
						W	L	H	A
NC8301C-1	131	5	76	8654	4066	14'-0" 4268mm	6'-4 3/4" 1950mm	10'-1 5/8" 3090mm	6'-8 1/4" 2039mm
NC8301DL-1	150	7 1/2	75	8792	4204				
NC8301EL-1	167	10	78	8798	4210				
NC8302D-1	184	7 1/2	74	11075	4818	15'-6" 4725mm	7'-10 3/4" 2407mm	10'-2 3/8" 3109mm	8'-2 1/4" 2496mm
NC8302E-1	204	10	76	11101	4844				
NC8302FL-1	229	15	76	11256	4999				
NC8303DL-1	204	7 1/2	72	11656	5399	15'-6" 4725mm	7'-10 3/4" 2407mm	11'-11 1/4" 3639mm	8'-2 1/4" 2496mm
NC8303E-1	229	10	76	11501	5244				
NC8303FL-1	259	15	76	11656	5399				
NC8303G-1	284	20	80	11717	5460	17'-0" 5182mm	8'-10 3/4" 2712mm	12'-11 3/4" 3956mm	9'-2 1/4" 2801mm
NC8303H-1	297	25	81	12022	5765				
NC8304CL-1	247	7 1/2	66	14003	6328				
NC8304D-1	270	10	72	13817	6142				
NC8304E-1	310	15	76	13983	6308				
NC8304EL-1	311	15	72	14092	6417				
NC8304F-1	339	20	77	14044	6369				
NC8304FL-1	339	20	73	14154	6479				
NC8304G-1	362	25	82	14072	6397				
NC8304GL-1	363	25	76	14303	6628				
NC8304H-1	370	30	83	14463	6788	18'-9" 5715mm	10'-10 3/4" 3321mm	12'-11 3/4" 3956mm	11'-2 1/4" 3410mm
NC8305CL-1	281	7 1/2	66	18563	8268				
NC8305D-1	316	10	72	18414	8119				
NC8305E-1	363	15	76	18543	8248				
NC8305F-1	403	20	77	18604	8309				
NC8305FL-1	393	20	73	18744	8449				
NC8305G-1	431	25	82	18662	8367				
NC8305GL-1	431	25	76	18892	8597				
NC8305H-1	453	30	83	18724	8429				
NC8305HL-1	450	30	77	18958	8663				
NC8305J-1	501	40	86	18872	8577	19'-10" 6046mm	11'-10 3/4" 3626mm	12'-11 3/4" 3956mm	12'-2 1/4" 3715mm
NC8306EL-1	405	15	71	22221	10408				
NC8306F-1	441	20	74	21725	9912				
NC8306G-1	474	25	77	21827	10014				
NC8306H-1	503	30	79	21862	10049				
NC8306J-1	557	40	81	22053	10240				
NC8306JL-1	556	40	78	22706	10893				
NC8306K-1	582	50	82	22969	11156				

**NOTE**

- Use this bulletin for preliminary layouts only. Obtain current drawings from your Marley sales representative. All table data is per cell.
- Last numeral of model number indicates number of cells. Change as appropriate for your selection.
- Nominal tons are based upon 95°F HW, 85°F CW, 78°F WB and 3 GPM/ton.
- Standard overflow is a 4" dia. standpipe in the collection basin floor. The standpipe removes for flush-out and draining. See page 22 for side overflow option.
- Outlet sizes vary according to GPM and arrangement. See pages 22 and 23 for outlet sizes and details.
- Makeup water connection may be 1" or 2" dia., depending upon tower heat load, water pressure, and desired connections. See page 17 for additional information.

# SYSTEM CONNECT

## DUAL INLET CONNECTION

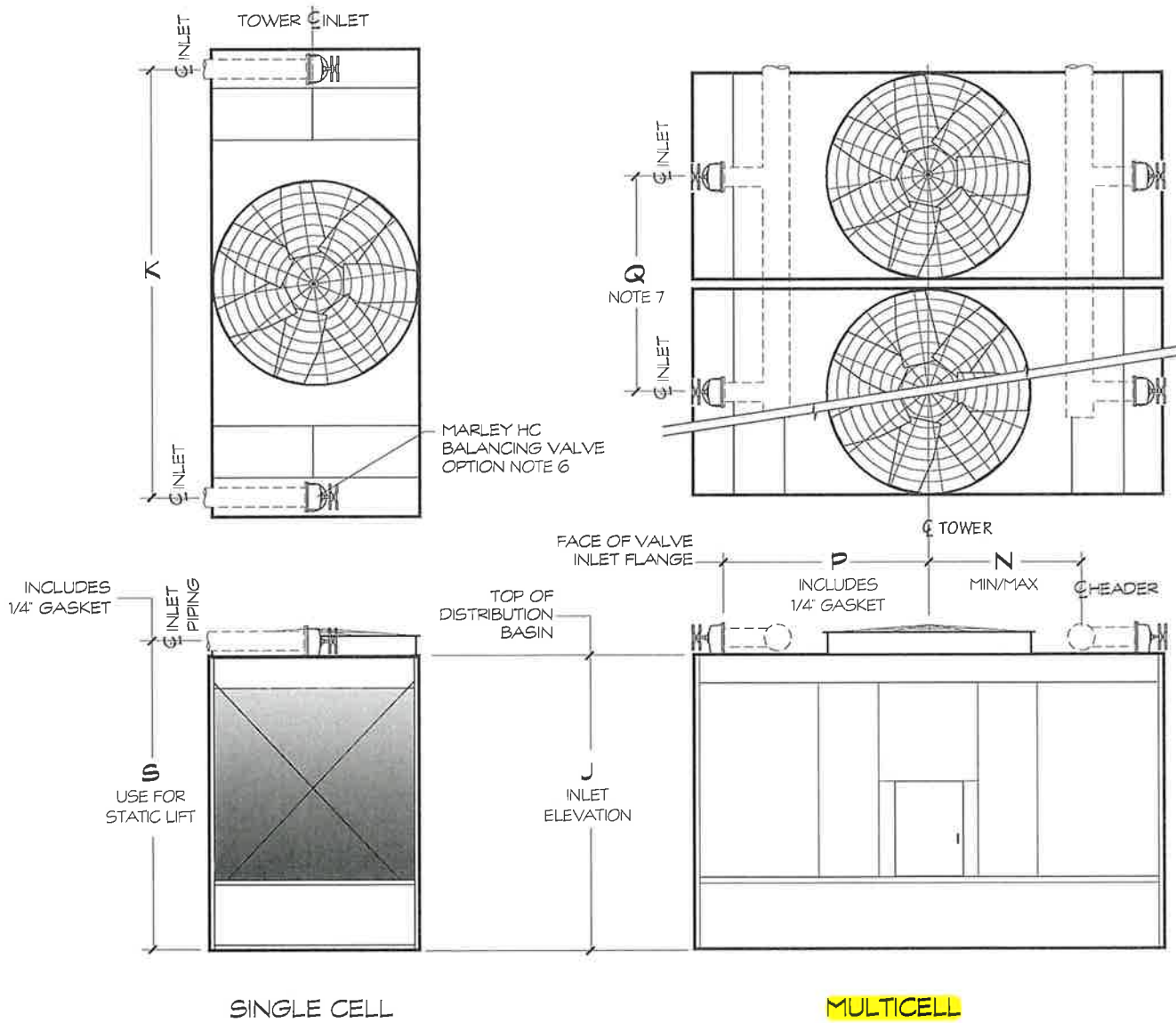

Tower Model	DIMENSIONS						Inlet Diameter	
	J	K	S	N MIN/MAX	P	Q		
NC8301	8'-8 1/16"	12'-3"	9'-4 15/16"	3'-11 1/2"	4'-10"	5'-10"	6'-8 1/4"	2 at 6"
NC8302	8'-8 1/16"	13'-9"	9'-4 15/16"	5'-10 1/4"	Fit "P"	6'-7"	8'-2 1/4"	2 at 6"
NC8303	10'-5 9/16"	13'-9"	11'-1 13/16"	5'-10 1/4"	Fit "P"	6'-7"	8'-2 1/4"	2 at 6"
NC8304	11'-5 9/16"	15'-3"	12'-1 13/16"	5'-10 1/4"	Fit "P"	7'-4"	9'-2 1/4"	2 at 6"
<b>NC8305</b>	<b>11'-5 9/16"</b>	<b>16'-10"</b>	<b>12'-2 13/16"</b>	<b>5'-11 3/4"</b>	<b>Fit "P"</b>	<b>8'-1 1/2"</b>	<b>11'-2 1/4"</b>	<b>2 at 8"</b>
NC8306	11'-5 9/16"	17'-11"	12'-2 13/16"	6'-1 5/8"	Fit "P"	8'-8"	12'-2 1/4"	2 at 8"
NC8307	11'-9 9/16"	20'-6"	12'-6 13/16"	6'-1 5/8"	Fit "P"	9'-11 1/2"	12'-2 1/4"	2 at 8"
NC8309	11'-9 9/16"	20'-3 1/2"	12'-8 13/16"	6'-10 5/8"	Fit "P"	9'-9 1/2"	14'-2 1/4"	2 at 10"

# SYSTEM CONNECT

## OUTLET CONNECTION

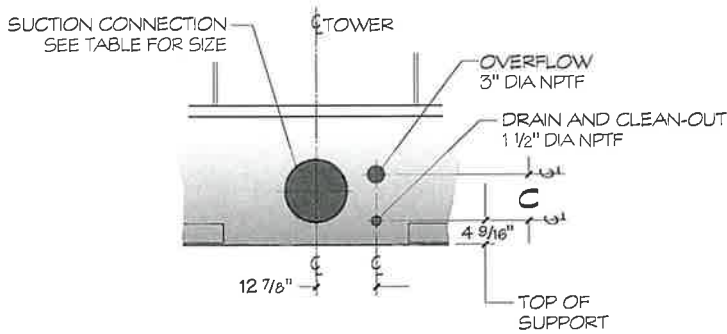

**DRAIN AND OVERFLOW CONNECTION**  
OPTION

Tower Model	DIMENSIONS		
	A	B	C
NC8301	10"	3'-3 3/16"	6 7/8"
NC8302	10"	4'-0 3/16"	6 7/8"
NC8303	10"	4'-0 3/16"	6 7/8"
NC8304	10"	4'-6 3/16"	6 7/8"
NC8305	10"	5'-6 3/16"	6 7/8"
NC8306	10"	6'-0 3/16"	6 7/8"
NC8307	11 1/4"	6'-0 3/16"	10 3/16"
NC8309	11 1/4"	7'-0 3/16"	10 3/16"
NC8310	11 1/4"	5'-6 3/16"	10 3/16"
NC8311	11 1/4"	6'-0 3/16"	10 3/16"
NC8312	11 1/4"	7'-0 3/16"	10 3/16"

**NOTE**

Standard overflow is a 4" dia. standpipe in the collection basin floor. The standpipe removes for flush-out and draining.

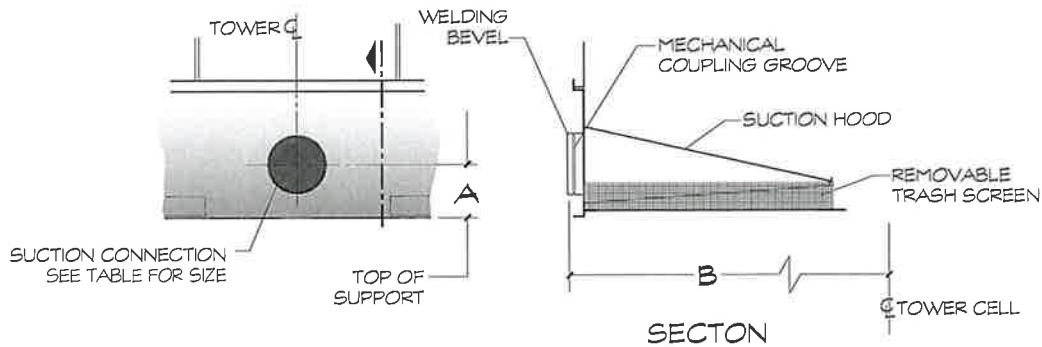

**SIDE-OUTLET SUCTION CONNECTION**

# TOWER SUPPORT

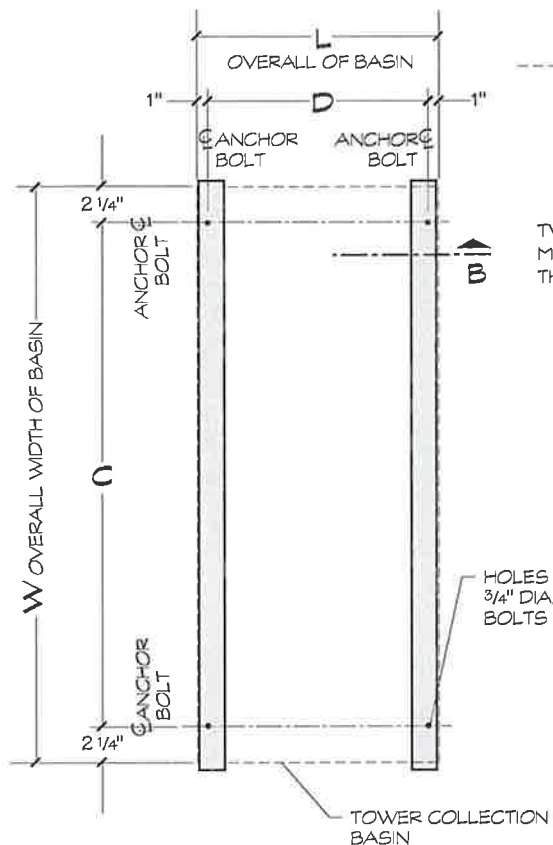

**SUPPORTING STEEL**  
SINGLE CELL

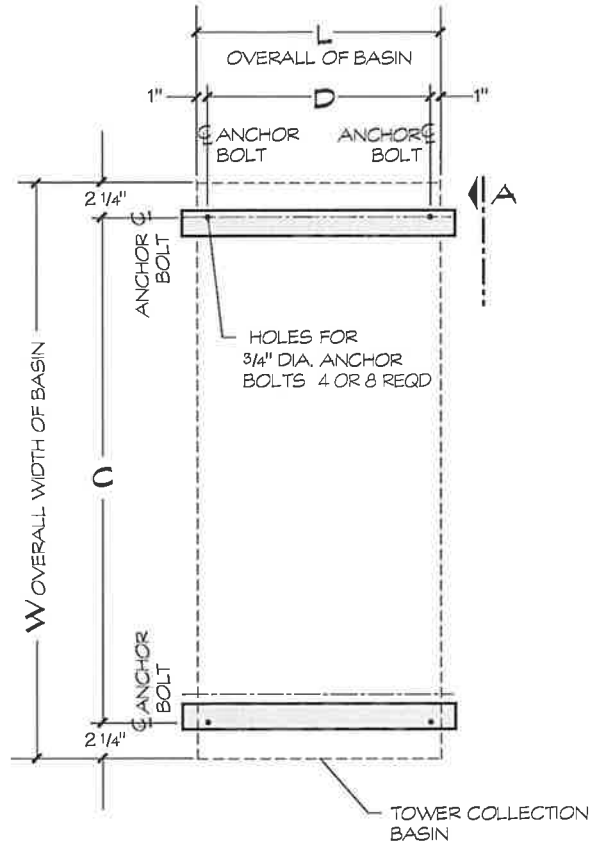

**SUPPORTING STEEL ALTERNATE**  
SINGLE CELL

Tower Model	DIMENSIONS					Design Operating Wt/Cell lb	Design Operating Load at Anchor lb	Wind/Seismic Loads lb Note 4	
	W	L	C	D	E Note 7			Max. Vertical Reaction at Anchor	Max. Horizontal Reaction at Anchor
NC8301	14'-0" 4268mm	6'-4 3/4" 1950mm	13'-7 1/2" 4153mm	6'-2 3/4" 1899mm	5 1/2" 140mm	8842	2211	1364/3461	943/2278
NC8302	15'-6" 4725mm	7'-10 3/4" 2407mm	15'-1 1/2" 4611mm	7'-8 3/4" 2356mm	5 1/2" 140mm	11256	2814	1221/3399	1046/2767
NC8303	15'-6" 4725mm	7'-10 3/4" 2407mm	15'-1 1/2" 4611mm	7'-8 3/4" 2356mm	5 1/2" 140mm	12022	3006	1737/4622	1248/3005
NC8304	17'-0" 5182mm	8'-10 3/4" 2712mm	16'-7 1/2" 5068mm	8'-8 3/4" 2661mm	5 1/2" 140mm	14463	3616	2019/5979	1498/3675
<b>NC8305</b>	<b>18'-9" 5715mm</b>	<b>10'-10 3/4" 3321mm</b>	<b>18'-4 1/2" 5601mm</b>	<b>10'-8 3/4" 3271mm</b>	<b>5 1/2" 140mm</b>	<b>18958</b>	<b>4740</b>	<b>1803/8606</b>	<b>1648/4877</b>
NC8306	19'-10" 6046mm	11'-10 3/4" 3626mm	19'-5 1/2" 5931mm	11'-8 3/4" 3576mm	5 1/2" 140mm	22969	5742	1759/9965	1750/5742
NC8307	22'-5" 6833mm	11'-10 3/4" 3626mm	22'-0 1/2" 6719mm	11'-8 3/4" 3576mm	5 1/2" 140mm	27256	6814	2090/8624	2029/6814
NC8309CL thru NC8309JL	22'-5" 6833mm	13'-10 3/4" 4236mm	22'-0 1/2" 6719mm	13'-8 3/4" 4185mm	5 1/2" 140mm	32097	8024	1801/10170	2037/7925
NC8309K and NC8309KL	22'-5" 6833mm	13'-10 3/4" 4236mm	22'-0 1/2" 6719mm	13'-8 3/4" 4185mm	5 1/2" 140mm	32261	8065	2271/10516	2256/8065
NC8310C thru NC8310H	22'-5" 6833mm	10'-10 3/4" 3321mm	22'-0 1/2" 6719mm	10'-8 3/4" 3271mm	5 1/2" 140mm	34087	8522	5405/16343	3121/8631
NC8310K	22'-5" 6833mm	10'-10 3/4" 3321mm	22'-0 1/2" 6719mm	10'-8 3/4" 3271mm	1'-0 3/4" 324mm	34330	8583	5606/16343	3304/8631
NC8311AL thru NC8311J	22'-5" 6833mm	11'-10 3/4" 3626mm	22'-0 1/2" 6719mm	11'-8 3/4" 3576mm	5 1/2" 140mm	37058	9265	4958/17503	3126/9286
NC8311K and NC8311KL	22'-5" 6833mm	11'-10 3/4" 3626mm	22'-0 1/2" 6719mm	11'-8 3/4" 3576mm	1'-0 3/4" 324mm	37305	9326	5779/18328	3353/9630
NC8312BL thru NC8312JL	22'-5" 6833mm	13'-10 3/4" 4236mm	22'-0 1/2" 6719mm	13'-8 3/4" 4185mm	5 1/2" 140mm	42981	10745	4248/21064	3131/10745
NC8312K thru NC8312R	22'-5" 6833mm	13'-10 3/4" 4236mm	22'-0 1/2" 6719mm	13'-8 3/4" 4185mm	5 1/2" 140mm	44427	10607	4971/21932	3364/11107

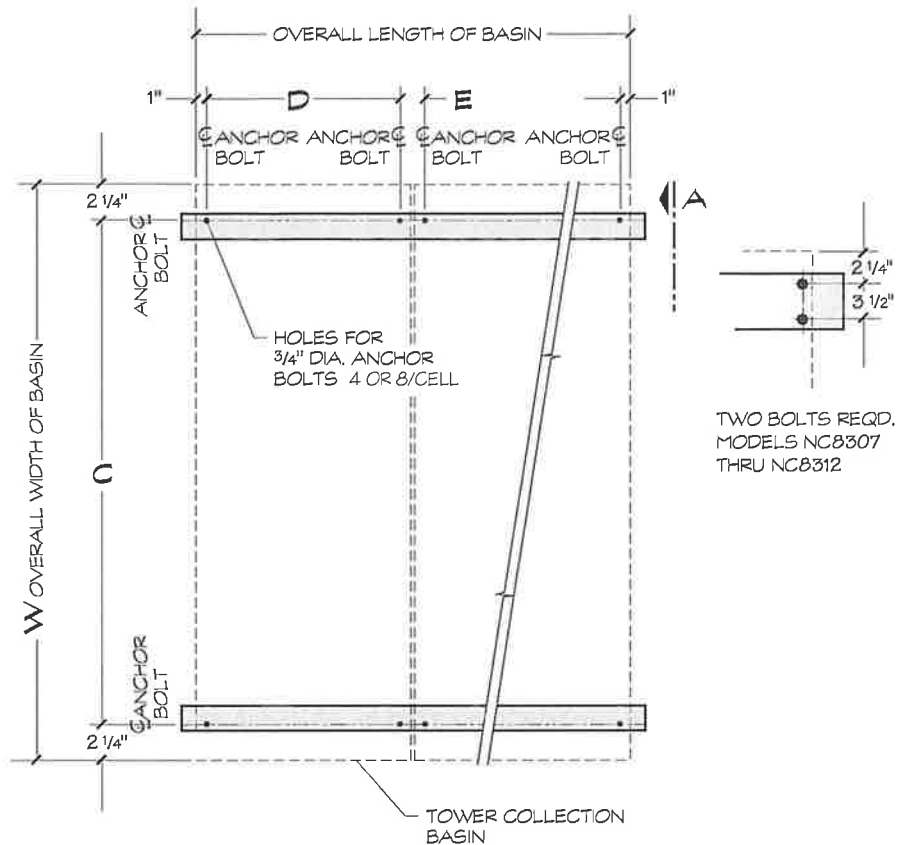

**SUPPORTING STEEL  
MULTICELL**

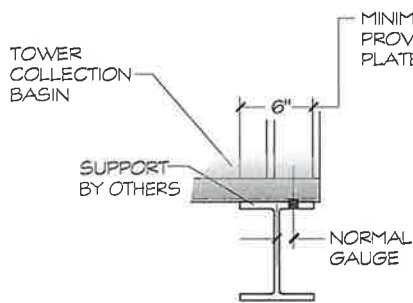

VIEW A

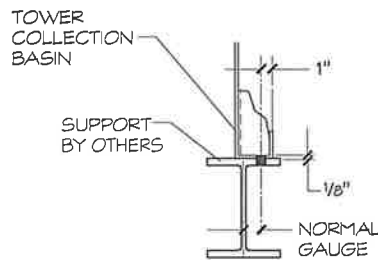

SECTION B

**NOTE**

- 1 Use this bulletin for preliminary layouts only. Obtain current drawings from your Marley sales representative for final design.
- 2 Purchaser to provide tower support complete with holes and anchor bolts. Do not use studs! Anchor points must be framed flush and level at top.
- 3 Design operating weight occurs with collection basin full to overflow level. Actual operating weight varies with GPM and piping scheme.
- 4 Wind loads are based on 30 psf and are additive to operating loads. Seismic loads will satisfy Zone 2B with importance factor of 1.0 per the 1997 UBC. Seismic reactions shown are for a 1g acceleration and may be factored down.
- 5 Tower may be placed on a flat concrete slab. Side outlet and optional side drain and overflow must be specified. See pages 16 and 22 and consult your Marley sales representative.
- 6 Tower may be supported from piers at each anchor bolt location, as a support alternative.
- 7 Dimensions between anchor bolts "E" may vary depending on the number of cells and options. Dimensions shown are for a standard two cell arrangement. Obtain current drawings from your Marley sales representative for final dimension.

# EXHIBIT C



# Document A310™ – 2010

Conforms with The American Institute of Architects AIA Document 310

## Bid Bond

### CONTRACTOR:

(Name, legal status and address)

DePue Mechanical, Inc.  
P. O. Box 857  
Minooka, IL 60447

### SURETY:

(Name, legal status and principal place of business)

The Cincinnati Insurance Company  
P.O. Box 145496  
Cincinnati, OH 45250-5496  
**Mailing Address for Notices**  
Same as above

This document has important legal consequences. Consultation with an attorney is encouraged with respect to its completion or modification.

### OWNER:

(Name, legal status and address)

Minooka Community High School District 111  
26655 W. Eames Street  
Channahon, IL 60410

Any singular reference to Contractor, Surety, Owner or other party shall be considered plural where applicable.

**BOND AMOUNT:** 10% Ten Percent of Amount Bid

### PROJECT:

(Name, location or address, and Project number, if any)

Water Cooling Tower Replacement

The Contractor and Surety are bound to the Owner in the amount set forth above, for the payment of which the Contractor and Surety bind themselves, their heirs, executors, administrators, successors and assigns, jointly and severally, as provided herein. The conditions of this Bond are such that if the Owner accepts the bid of the Contractor within the time specified in the bid documents, or within such time period as may be agreed to by the Owner and Contractor, and the Contractor either (1) enters into a contract with the Owner in accordance with the terms of such bid, and gives such bond or bonds as may be specified in the bidding or Contract Documents, with a surety admitted in the jurisdiction of the Project and otherwise acceptable to the Owner, for the faithful performance of such Contract and for the prompt payment of labor and material furnished in the prosecution thereof; or (2) pays to the Owner the difference, not to exceed the amount of this Bond, between the amount specified in said bid and such larger amount for which the Owner may in good faith contract with another party to perform the work covered by said bid, then this obligation shall be null and void, otherwise to remain in full force and effect. The Surety hereby waives any notice of an agreement between the Owner and Contractor to extend the time in which the Owner may accept the bid. Waiver of notice by the Surety shall not apply to any extension exceeding sixty (60) days in the aggregate beyond the time for acceptance of bids specified in the bid documents, and the Owner and Contractor shall obtain the Surety's consent for an extension beyond sixty (60) days.

If this Bond is issued in connection with a subcontractor's bid to a Contractor, the term Contractor in this Bond shall be deemed to be Subcontractor and the term Owner shall be deemed to be Contractor.

When this Bond has been furnished to comply with a statutory or other legal requirement in the location of the Project, any provision in this Bond conflicting with said statutory or legal requirement shall be deemed deleted herefrom and provisions conforming to such statutory or other legal requirement shall be deemed incorporated herein. When so furnished, the intent is that this Bond shall be construed as a statutory bond and not as a common law bond.

Signed and sealed this 12th day of April, 2024.

  
\_\_\_\_\_  
(Witness)

  
\_\_\_\_\_  
(Witness) Dave Roth

DePue Mechanical, Inc.  
\_\_\_\_\_  
(Principal) (Seal)

By:   
\_\_\_\_\_  
(Title) VP of Business Development

The Cincinnati Insurance Company  
\_\_\_\_\_  
(Surety) (Seal)

By:   
\_\_\_\_\_  
(Title) Quanda Warren, Attorney-in-Fact



THE CINCINNATI INSURANCE COMPANY  
THE CINCINNATI CASUALTY COMPANY

Fairfield, Ohio

POWER OF ATTORNEY

KNOW ALL MEN BY THESE PRESENTS: That THE CINCINNATI INSURANCE COMPANY and THE CINCINNATI CASUALTY COMPANY, corporations organized under the laws of the State of Ohio, and having their principal offices in the City of Fairfield, Ohio (herein collectively called the "Companies"), do hereby constitute and appoint **Quanda Warren** its true and legal Attorney-in-Fact to sign and deliver on behalf of the Companies as Surety, at any place within the United States, the following surety bond:

Surety Bond Number: Bid Bond  
Principal: DePue Mechanical, Inc.  
Obligee: Minooka Community High School District 111

This appointment is made under and by authority of the following resolutions adopted by the Boards of Directors of The Cincinnati Insurance Company and The Cincinnati Casualty Company, which resolutions are now in full force and effect, reading as follows:

RESOLVED, that the President or any Senior Vice President be hereby authorized, and empowered to appoint Attorneys-in-Fact of the Company to execute any and all bonds, policies, undertakings, or other like instruments on behalf of the Corporation, and may authorize any officer or any such Attorney-in-Fact to affix the corporate seal; and may with or without cause modify or revoke any such appointment or authority. Any such writings so executed by such Attorneys-in-Fact shall be binding upon the Company as if they had been duly executed and acknowledged by the regularly elected officers of the Company.

RESOLVED, that the signature of the President or any Senior Vice President and the seal of the Company may be affixed by facsimile on any power of attorney granted, and the signature of the Secretary or Assistant Vice-President and the Seal of the Company may be affixed by facsimile to any certificate of any such power and any such power of certificate bearing such facsimile signature and seal shall be valid and binding on the Company. Any such power so executed and sealed and certified by certificate so executed and sealed shall, with respect to any bond or undertaking to which it is attached, continue to be valid and binding on the Company.

IN WITNESS WHEREOF, the Companies have caused these presents to be sealed with their corporate seals, duly attested by their President or any Senior Vice President this 16th day of March, 2021.



STATE OF OHIO )SS:  
COUNTY OF BUTLER )

THE CINCINNATI INSURANCE COMPANY  
THE CINCINNATI CASUALTY COMPANY

*Stephen A. Ventre*

On this 16th day of March, 2021 before me came the above-named President or Senior Vice President of The Cincinnati Insurance Company and The Cincinnati Casualty Company, to me personally known to be the officer described herein, and acknowledged that the seals affixed to the preceding instrument are the corporate seals of said Companies and the corporate seals and the signature of the officer were duly affixed and subscribed to said instrument by the authority and direction of said corporations.



*Keith Collett*  
Keith Collett, Attorney at Law  
Notary Public - State of Ohio  
My commission has no expiration date.  
Section 147.03 O.R.C.

I, the undersigned Secretary or Assistant Vice-President of The Cincinnati Insurance Company and The Cincinnati Casualty Company, hereby certify that the above is the Original Power of Attorney issued by said Companies, and do hereby further certify that the said Power of Attorney is still in full force and effect.

Given under my hand and seal of said Companies at Fairfield, Ohio, this 12th day of April, 2024.



*Ed H.*



04/12/2024

REVISION: 0

ATTN: Minooka Community High School District 111

RE: Water Cooling Tower Replacement  
Helm quote #24-0740

**HELM SERVICE** is pleased to provide the following proposal for the **MECHANICAL** scope for the above referenced project.

Addenda: Addendum 1 – Received

**GENERAL SCOPE:**

The following proposed amount is all inclusive with labor, material and equipment necessary to replace the colling tower at Minooka Community High School District 111, South Campus.

**Cooling tower replacement scope**

- i. Cooling tower replaced
- ii. Piping from cooling tower to piping on the exterior wall.
- iii. Pipe insulation

New Tower Spec’s (we have a copy of the equipment specifics for the existing tower avail if needed)

TOWER MODEL	PERFORMANCE CONDITIONS	MOTOR DATA	TOWER DIMENSIONS	WEIGHTS
Quantity of (1) Marley NC Class model <b>NC8405QAN</b> factory assembled 2-Cell crossflow cooling tower	Per 2-cell tower: 2,400 gpm 95.0 °F Hot Water 85.0 °F Cold Water 78.0 °F Entering WB	NEMA 20 HP 1 speed / 1 wind 3 phase / 60 Hz / <b>230/460v</b> 1.15sf / TEFC 1800 RPM Premium Efficiency Inverter duty nameplated Site Voltage; 480	Each cell: (without options) Length 9' - 10 3/4" Width 19' - 11" Height 11' - 11 3/4" Per 2-cell tower: (with options) Length 20' - 9 15/16" Width 19' - 11" Height 15' - 0 7/8"	Per cell: Shipping: 9,352 lb Operating: 20,148 lb Per 2-cell tower: Shipping: 18,704 lb Operating: 40,296 lb

- The new cooling tower shall be **stainless steel casing, structure, and basins.**
- Variable frequency Drive (VFD) included for tower fan.
- The cooling tower shall have liquid alarms for Makeup, High Alarm, and Low Alarm with feedback to the BAS.

**Mechanical:**

- i. Demo and install new cooling tower
- ii. install all shipped loose items such as ladder, handrails, fan guards, etc. (caged ladder, handrails, and fan guards are required as per original unit)
- iii. fabricate and install approx. 100 ft of 8” cs sch 40 pipe with grooved ends
- iv. fabricate and install approx. 60 feet of 6” cs sch 40 pipe with grooved ends
- v. fabricate and install approx. 20 ft of 10” cs 40 pipe with grooved ends
- vi. furnish and install all required vic clamps with gaskets (water service)
- vii. furnish and install 10’ equalization line including drain valve
- viii. furnish and install water make up line using pro-press copper
- ix. furnish and install overflow drain using pvc schedule 40 pipe.
- x. Install new cooling tower and all loose shipped items, ( i.e. handrails, fan guards, etc.)



xi. all piping to wire brushed and solvent cleaned. Roller apply one (1) coat PPG's Amerlock 2 epoxy and two coats of PPG's durethane. All painting to be completed after installation of

**Electrical**

- i. Demolition of conduits and wiring supported to existing tower.
- ii. cooling tower motor disconnects
- iii. Pull wire and cable back to junction boxes located inside building
- iv. Two (2) new NEM 3R 60 amp disconnects
- v. Two (2) motor disconnects
- vi. Six (6) instrument connections
- vii. All new rigid conduit, fittings, and wire
- viii. all terminations, testing and labels

**Demolition & Installation**

- a. Demolition and installation shall be coordinated with School District. It is anticipated that this work will occur while the building is occupied. Contractor to coordinate all staging, craning, and demolition work in a manner to ensure safety and well-being of students and staff.
- b. Any and all work shown to be carried out in accordance with all governing federal, state, and local codes, including OSHA.
- c. Contractor to shore and support any existing construction to remain until all new construction and imposed loads are in place.
- d. Anything removed that can be recycled shall be recycled.
- e. All removed equipment must be disposed of by contractor
- f. all lifts and cranes to be supplied by contractor.

**.Testing, Commissioning, Water Treatment**

- a. Testing and commissioning to be conducted by contractor. The contractor must submit a comprehensive testing and commissioning plan with checkoff lists. This testing and commissioning plan shall ensure that the unit once turned over to the School District complies with the operational needs of the School District and the manufacturers design and installation specifications.
- b. Contractor will review and document whether the District's current water treatment system is compatible with the operation of the cooling tower and appropriate in accordance with the cooling tower manufacturer instructions and warranty. If changes to the District's water treatment system are necessary contractor shall promptly notify the District.

**Training & Documentation**

- a. Supply District training for proper use and maintenance of all new equipment including winterization.
- b. Provide owner with operation and service manuals for all new installed equipment including "as-built" drawings.

**Warranty**

**-Marley designed Geareducer® with 5-year warranty.  
-5 year parts-only warranty included standard with SS constructed tower**

**Exclusions:**

- |   |  |
|---|--|
| 1. Bonds, permits, or allowances                      | 8. Concrete work of any type (i.e. housekeeping pads)                              |
| 2. Utility fees                                       | 9. Grouting of any kind (i.e. vessels, equipment bases, floor support stands, etc) |
| 3. MBE/WBE or workforce requirements                  | 10. Seismic restraints / seismic calculations                                      |
| 4. Saw cutting or patching floors, drives, walks etc. | 11. Temporary Heat, Ventilation, & Air Conditioning                                |
| 5. Rock or frost excavation                           | 12. Loose motor starters / disconnects   |
| 6. Temporary water piping or heat tracing             |  |
| 7. Temporary storm drains                             |  |

- 13. Final electrical connections to our equipment
- 14. Structural roof support steel
- 15. Overtime premium
- 16. Toilet accessories or backing
- 17. Indoor air quality testing
- 18. Equipment warranty extension past mfr's std

- 19. Architectural sheet metal & equipment screens
- 20. Painting of any kind
- 21. Smoke and Fire Dampers not shown on drawings
- 22. Anchorage testing

**Notes:**

- Helm is not responsible for delays due to supply chain issues or material lead times.
- This proposal is valid for 60 days from date of proposal after which time it is subject to review & confirmation.
- All ductwork fabricated to current SMACNA duct construction standards.
- All available construction drawing files, in REVIT and dwg format, provided to us at no cost. All addenda & pre-contract RFI items shall be integrated into the files prior to release to us.
- Temporary sanitation facilities and OSHA approved temp lighting & power provided by others.
- Structural members shall be designed to carry MEP hanger loads. No special hangers or supplemental steel is included.
- Dumpsters for our use shall be provided by others.
- Terms: monthly progress payments, payable Net 30. Payments allowed for stored material either on jobsite, at shop, or at insured warehouse.

**BASE BID FOR THE ABOVE HVAC SCOPE OF WORK .....\$413,201.00(excl tax)**

**\*\*We are including an allowance of \$10k for painting**

**\*\*We recommend carrying an additional allowance for DDC of .....\$10,000.00**

**\*\*Additional cost for SPX Cooling Tech, LLC Certification of Limited Warranty ("Warranty Certificate") 5 year labor warranty. All other terms of the Warranty Certificate remain unchanged and in effect.....\$15,710.00**

If you have any questions or need additional information, please feel free to contact me.

Sincerely,

Tom Burke  
[tburke@helmgroupp.com](mailto:tburke@helmgroupp.com)  
 815-990-0064

26655 W. Eames Street  
Channahon, IL 60410

# Assurances and Certifications

## PART 1

### STATEMENT OF ETHICS CERTIFICATION

By submission of this bid or proposal, the bidder certifies that:

1. This bid or proposal has been independently arrived at without collusion with any other bidder or with any competitor.
2. This bid or proposal has not been knowingly disclosed and will not be knowingly disclosed, prior to the opening of bids or proposals for this project, to any other bidder, competitor or potential competitor.
3. No attempt has been made or will be made to induce any other person, partnership or corporation to submit or not to submit a bid or proposal.
4. Bidder has not been convicted of price fixing nor pleaded "no contest" to such charges within the last five (5) years.
5. Bidder is not subsidiary of a company that has been convicted of price fixing nor pleaded "no contest" to such charges within the last five (5) years.

By: Jeffery E. McCoy Jeffery E. McCoy - President  
Authorized Agent

SUBSCRIBED and SWORN TO before me

this 10<sup>th</sup> day of April, 20 21

Andrea Rezich  
NOTARY PUBLIC



This page must be returned signed and notarized for the bid to be considered.

Minooka Community High School District 111

26655 W. Eames Street  
Channahon, IL 60410

## Assurances and Certifications PART 2

### SUPPLIER'S/CONTRACTOR'S CERTIFICATION

As part of its bid, the supplier/contractor does hereby certify that said supplier/contractor is not barred from bidding on the contract as a result of violation of either Section 33E-3 or 33E-4 of Article 33E of Chapter 38 of the Illinois Revised Statutes.

By: Jeffery E. McCoy Jeffery E. McCoy - President  
Authorized Agent

### CERTIFICATE OF COMPLIANCE WITH ILLINOIS DRUG-FREE WORKPLACE ACT (Suppliers/Contractors with 25 or More Employees)

As part of its bid, the supplier/contractor does hereby certify pursuant to section 3 of the *Illinois Drug-Free Workplace Act* (Ill.Rev.Stat. ch 127. para. 132.313) that [he, she, it] shall provide a drug-free workplace for all employees engaged in the performance or work under the contract by complying with the requirements of the *Illinois Drug-Free Workplace Act* and, further certifies, that [he, she, it] is not ineligible for award of this contract by reason of debarment for a violation of the *Illinois Drug-Free Workplace Act*.

By: Jeffery E. McCoy Jeffery E. McCoy - President  
Authorized Agent

Does Not Apply (Less than 25 Employees)

By: Jeffery E. McCoy Jeffery E. McCoy - President  
Authorized Agent

SUBSCRIBED and SWORN TO before me

this 10<sup>th</sup> day of April, 2024

Andrea Rezych  
NOTARY PUBLIC



This page must be returned signed and notarized for the bid to be considered.

Minooka Community High School District 111  
26655 W. Eames Street  
Channahon, IL 60410  
**Assurances and Certifications**  
**PART 3**

CERTIFICATE OF COMPLIANCE WITH ILLINOIS HUMAN RIGHTS ACT

**Sexual Harassment Policies**

As part of its bid, the supplier/contractor does hereby certify pursuant to 775 ILCS 5/2-105 that [he, she, it] has written sexual harassment policies that include at least the minimum information as required by law; that a copy of the policies shall be provided to the Department of Human Rights upon request; and that [he, she, it] is not ineligible for award of this contract by reason of debarment for a violation of the *Illinois Human Rights Act*.

By: Jeffery E. McCoy Jeffery E. McCoy - President  
Authorized Agent

**Equal Employment Opportunity**

As part of its bid, the supplier/contractor does hereby certify pursuant to 775 ILCS 5/2-104 that [he, she, it] complies with the procedures and requirement of the Illinois Department of Human Rights regulations concerning equal employment opportunities and affirmative action, shall provide such information with respect to its employees and applicants for employment and assistance as the Department may reasonably request, and that [he, she, it] is not ineligible for award of this contract by reason of debarment for a violation of the *Illinois Human Rights Act*.

By: Jeffery E. McCoy Jeffery E. McCoy - President  
Authorized Agent

SUBSCRIBED and SWORN TO before me

this 10<sup>th</sup> day of April, 20 24

Andrea Rezych  
NOTARY PUBLIC



**This page must be returned signed and notarized for the bid to be considered.**

Minooka Community High School District 111  
26655 W. Eames Street  
Channahon, IL 60410  
**Assurances and Certifications**  
**PART 4**

AGREEMENT TO BE BOUND BY THE TERMS OF THE BID

If the contract is awarded to the contractor, the contractor hereby adopts, accepts, and agrees to be bound by all the terms and conditions of the MINOOKA COMMUNITY HIGH SCHOOL DISTRICT 111 WATER COOLING TOWER REPLACEMENT bid.

By: Jeffery E. McCoy Jeffery E. McCoy - President  
Authorized Agent

**Equal Employment Opportunity**

SUBSCRIBED and SWORN TO before me

this 10th day of April, 2024

Andrea Rezich  
NOTARY PUBLIC



**This page must be returned signed and notarized for the bid to be considered.**



4632 W. Lawrence Avenue – Chicago, IL 60630  
Phone # (773) 267-6300 Fax # (773) 267-6333  
[info@coremechanicalinc.com](mailto:info@coremechanicalinc.com)

**MINOOKA COMMUNITY HIGH SCHOOL DISTRICT 111  
ATTENTION: MR. JOHN TROY  
ASSISTANT SUPERINTENDENT OF BUSINESS &  
GENERAL COUNCIL  
26655 W. EAMES STREET  
CHANNAHON, IL 60410**

***MINOOKA COMMUNITY HIGH SCHOOL DISTRICT 111***

***WATER COOLING TOWER  
REPLACEMENT***

**SUBMITTED BY:  
CORE MECHANICAL, INC.  
4632 W. LAWRENCE AVENUE  
CHICAGO, IL 60630**

**INVITATION TO BID ON THE  
MINOOKA COMMUNITY HIGH SCHOOL DISTRICT 111  
WATER COOLING TOWER REPLACEMENT**

Addendum #1

The following language is hereby added and included in the bid document:

**BID BOND**

Contractor shall submit with the bid a Bid Bond satisfactory to the District, executed by Surety Company authorized to do business in the state or otherwise secured in a manner satisfactory to the District, in an amount equal to 10% of the price specified.

**Minooka Community High School District 111  
26655 W. Eames St.  
Channahon, IL 60410**

**INVITATION TO BID ON THE  
MINOOKA COMMUNITY HIGH SCHOOL DISTRICT 111  
WATER COOLING TOWER REPLACEMENT**

Minooka Community High School District 111 is soliciting bids for replacement of the District's water cooling tower at the District's South Campus. **Deadline for Return is Friday April 12, 2024 at 10:00am.**

**BIDS ARE TO BE SUBMITTED TO**

Minooka Community High School District 111  
Attn: Mr. John Troy, Assistant Superintendent of Business & General Counsel  
26655 W. Eames St.,  
Channahon, IL 60410

Marked with "Cooling Tower Proposal" on the outside of envelope

**1. OPENING OF BIDS**

Minooka Community High School District 111, Grundy County, Illinois is requesting bids per the attached specifications for a **water cooling tower replacement**. Bids must be mailed to Mr. John Troy, Assistant Superintendent of Business & General Counsel no later than 10:00 am Friday, April 12, 2024, at which time they will be opened and acknowledged. Bids will be studied and reviewed and it is anticipated that a recommendation will be made to the Board of Education for award of Bid on Wednesday, April 17, 2024. The Board of Education reserves the right to waive any informalities, irregularities, or defects in any proposal should it be in the best interest of the school District to do so.

**2. PREPARATION OF PROPOSAL**

Proposal must be submitted on the prescribed Bid Form at the end of this document. Proposals will be opened immediately after the deadline. The method of transmittal of the proposal is at the seller's risk of untimely receipt by the Board. The District will not be responsible for delays in delivery due to electronic means. All bids will be acknowledged received, if you submitted a bid and did not receive an acknowledgement contact John Troy at 815-521-4294. Late bids will be returned unopened to the sender.

**3. METHODS OF AWARD**

The Board of Education reserves the right to reject any and all bids or to accept a bid in whole or in divisible part if deemed to be in the best interest of the School District. The Board of Education reserves the right to choose alternates it deems to be in the best interest of the School District. The Board of Education shall have the right and authority to award orders to the bidder or bidders best meeting all specifications and conditions based upon the sole judgment of the Board. Bids may be accepted in whole or in part, i.e., depending on the cost the District may decide not to do one or more or aspects of the bid.

In making its determination the following qualifications in addition to price will be considered by the Board:

- a. The ability, capacity and skill of the Bidder to perform the service required.
- b. Whether the Bidder can perform the contract or provide the service promptly, or within the time specified, without delay or interference
- c. The character, integrity, reputation, judgment, experience and efficiency of the Bidder.
- d. The quality of performance of previous contracts or services.
- e. The previous and existing compliance by the Bidder with laws and ordinances relating to the contract or service
- f. The sufficiency of the financial resources and ability of the Bidder to perform the contract or provide the service
- g. The quality, availability and adaptability of the supplies, or services, to the particular use required
- h. The ability of the Bidder to provide future maintenance and service for the use of the subject of the contract
- i. Past history and performance that the Bidder may have with the District.
- j. References from past school District clients of Bidder.
- k. Such other information as may be secured having a bearing on the decision to make the award
- l. Consideration will be given to standardization, interchangeability and availability of parts, if applicable to bid.
- m. In determining a bidder's responsiveness, the Board shall consider material deviations from the advertised specifications which materially affect price, quantity or limit the bidder's liability

Proposers and other interested parties are cordially invited to be present at the public proposal opening to be held at the time the sealed proposals are due. Proposals will be publicly opened and results announced.

#### **4. DURATION AND WITHDRAWAL OF BIDS**

All bids shall be binding for 60 calendar days following the bid opening date, unless the bidder, upon request of the District, agrees to an extension. A written request for the withdrawal of the bid or any part thereof may be granted if the request is received by the District prior to the specified time of bid opening. No bids may be withdrawn after they have been opened.

#### **5. CERTIFICATES & ASSURANCES**

All bidders shall submit all certificates herein contained and as required by law.

#### **6. INVOICES**

The successful Contractor shall submit three copies of invoices. Payment to the contractor shall be made within 30 days after receipt of invoice and approval by the Board of Education. Payments are approved by the Board of Education at its monthly Board meeting (typically the third Wednesday of each month) provided a valid invoice is received at least two weeks prior to the Board meeting and said service has been provided and accepted by the Board of Education. **Invoices must be accompanied by certified payroll.**

#### **7. COMPLETION DELIVERY TIME**

All work must be scheduled with the building & grounds department and must be completed by November 1, 2024.

**8. LATE BIDS**

Formal bids, amendments thereto, or requests for withdrawal of bids received by the District after the time specified for bid opening will not be considered.

**9. PERFORMANCE BOND:**

The following bonds shall be delivered to the District and shall become binding with the acceptance of the bid. Performance bond satisfactory to the District, executed by Surety Company authorized to do business in the state or otherwise secured in a manner satisfactory to the District, in an amount equal to 110% of the price specified.

**10. COMPLETENESS**

All information required by the Invitation to Bid must be supplied to constitute a proper bid.

**11. AUTHORITY TO ACT AS AGENT**

Upon request, the bidder will provide proof to the District that the signatory on the proposal form has the authority to bind the bidder to the price(s) quoted.

**12. DEVIATIONS**

In the event that the Bidder intends to deviate from the specifications, all such deviations must be listed and attached to the bid. The absence of a submitted deviations will assure the District that no deviations from specifications exist.

**13. QUESTIONS REGARDING SPECIFICATIONS**

Should a bidder find discrepancies or omissions in the specifications or instructions, or should he/she be in doubt as to their true meaning, he/she should notify the Assistant Superintendent who will, in turn, clarify such specifications and notify other bidders of any material change or clarification. The Board of Education shall not be held responsible for oral instruction to bidders. **No questions will be accepted 24 hours prior to the bid opening.**

**14. SUBLETTING CONTRACT**

It is mutually understood and agreed that the Bidder shall not assign, transfer, convey, sublet, or otherwise dispose of his/her contract or right, title or interest therein, or power to execute such contract, to any other person, firm or corporation, without the previous written consent of the District, but in no case shall such consent relieve the Bidder from his/her obligation, or change the terms of the Contract.

Furthermore, the contractor shall not allow a subcontractor to commence work on any portion of the project without evidence that the subcontractor has insurance coverage equal to coverages required of the contractor by the District.

**15. NON-DISCRIMINATION**

No bidder who is the recipient of the District's funds, or proposes to perform any work or furnish any goods under this agreement shall discriminate against any worker, employee or applicant or any member of the public because of religion, race, sex, color, or national origin, nor otherwise commit any unfair employment practice. Bidder further agrees that this article will be incorporated by the bidder into all contracts entered into with

suppliers of materials or services, contractors and subcontractors and all labor organizations furnishing skilled, unskilled, and craft union skilled labor, or who may perform any such labor or services in connection with this contract.

**16. SEXUAL HARASSMENT POLICY**

Every party to a public contract and every eligible bidder must have a written sexual harassment policy that shall include, at a minimum, the following information: (i) the illegality of sexual harassment; (ii) the definition of sexual harassment under state law; (iii) a description of sexual harassment, utilizing examples; (iv) the recourse, investigative and complain process available through the Illinois Department of Human Rights and the Human Rights Commission; (v) directions on how to contact the Department and Commission; and (vi) protection against retaliation as provided by Section 6-101 of the Human Rights Act.

**17. INDEMNITY**

Contractor shall indemnify, keep and save harmless the District, its agents, officials and employees, against all injuries, death, loss, damages, claims, patent claims, suits, liabilities, judgments, cost and expenses, which may in any way accrue against the District in consequence of the granting of this contract or which in any way result therefrom, whether or not it shall be alleged or determined that the act was caused through negligence or omission of the Contractor or his employees, and the contractor shall, at his/her own expense, appear, defend and pay all charges of attorneys and all costs and other expenses arising therefrom or incurred in connection therewith, and if any judgment shall be rendered against the District in any such action, the contractor shall, at his/her own expense, satisfy and discharge the same. Contractor expressly understands and agrees that any performance bond or insurance protection required by this contract, or otherwise provided by bidder, shall in no way limit the responsibility to indemnify, keep or save harmless and defend the District as herein provided.

**18. COLLUSIVE BIDDING**

The bidder certifies that his/her bid is made without any previous understanding, agreement or connection with any person, firm, or corporation making bid for the same project, and is in all respects fair, without outside control, collusion, fraud, or otherwise illegal action.

**19. IDENTICAL BIDDING - EXECUTIVE ORDER NO. 10946**

All identical bids submitted to the District as a result of advertised procurement for materials, supplies, equipment or services exceeding \$2,500.00 in total amount shall, at the discretion of the District, be reported to the Attorney General of the United States in accordance with Form DJ-1510 and the Presidential Order dated April 24, 1961 for possible violation and enforcement of antitrust laws.

**20. CONTRACTOR NOT AN AGENT**

The contractor shall not be held or deemed in any way to be an agent, employee, or official of the District, but rather an independent contractor furnishing services to the District.

**21. RESPONSIBILITY FOR MATERIALS SHIPPED**

The contractor shall be responsible for the materials or supplies covered by this contract until they are installed and turned over to the District. The contractor shall bear all risk on rejected materials and supplies after notice of rejection. Rejected materials or supplies must be promptly removed by and at the expense of the contractor after notification of rejection.

## **22. INSPECTIONS**

If applicable, for supplies and materials purchases - inspection and acceptance of will be made after delivery. Final inspection shall be conclusive except as regards latent defects, fraud, or such gross mistakes as amount to fraud. Final inspection and acceptance or rejection of the materials or equipment will be made as promptly as practicable, but failure to inspect or accept or reject materials or equipment shall not impose liability on the District for such materials or equipment as are not in accordance with the specifications. All delivered materials shall be accepted subject to inspection and physical count.

Contractors or vendors should be aware that the District is required by state law to follow and adhere to all local municipal building and zoning codes.

## **23. PREVAILING WAGE**

The awarded Contractor is required to pay all applicable wage rates as required and stipulated by Federal, State and Local laws and **Contractor agrees to pay prevailing wages for all work completed under this contract.**

The contractor and all subcontractors shall use the "CERTIFIED TRANSCRIPT OF PAYROLL" and "AFFIDAVIT" forms as prepared by the Illinois Department of Labor. Electronic Versions of these forms are available from the Illinois Department of Labor. Pay requests will not be processed until current certified payrolls are provided for contractor and subcontractors.

## **24. INSURANCE**

The District upon awarding a project requires a Certificate of Insurance with "Additional Insured Endorsement in such amounts as deemed acceptable by the District . Proposed insurance limits must be submitted with the proposal. You must require your insurance company to list the District as "Additional Insured". In the "Description of Operations locations/Vehicles/Special Items" section of the Certificate it must state: "Minooka Community High School District 111 and its Board of Education are added as additional insured and included on an Additional Insured Endorsement.

### **Contractor must submit a Certificate of Liability Insurance "Accord" form with Liability Insurance Limits**

Minimum occurrence based insurance requirements are as follows:

- (i) Workers' Compensation and Employer's Liability Insurance as required by applicable State of Illinois law.
- (ii) Commercial General Liability Insurance, including contractual liability, Bodily Injury \$2 million per occurrence, and \$4 million aggregate; Property Damage \$2 million occurrence, and \$4 million aggregate; Personal Injury \$2 million per occurrence and \$4 million aggregate.
- (iii) Comprehensive Automobile Liability Insurance, including owned, non-owned and hired automotive equipment of, Bodily Injury per person, \$1 million occurrence per and \$3 million aggregate, Property Damage \$1 million per occurrence and \$3 million aggregate.
- (iv) Limits on General Liability and Comprehensive Auto Liability may be less if providing an Umbrella liability policy of not less than \$5 million covering all claims under subparagraphs (ii) and (iii).

**25. SAFETY**

The contractor shall provide all barricades, security, and signage necessary to control vehicle and pedestrian traffic and to protect the project and staging area while work is in progress.

**26. CRIMINAL BACKGROUND INVESTIGATIONS**

Due to performing work during the time students are in session criminal background checks of contractor and subcontractor employees are required. Contractor hereby represents, warrants and certifies that no officer or director of vendor has any knowledge that any employee thereof has been convicted of committing or attempting to commit any one or more of the following offenses set forth in Section 5/21-23a of the Illinois School Code or who falsifies, or omits facts from his or her employment documents.

Contractor agrees that it shall not employ on this project any person for whom a criminal background investigation has not been conducted pursuant hereto, and further represents and agrees that all employees or applicants who work on District grounds shall be required to furnish a written "Authorization for Criminal Background Information" on forms provided by the District authorizing the Board of Education to request a criminal background investigation of said person pursuant to 105 ILCS 5/10-21-9 as amended by P.A. 96-1452 and to receive criminal history record information pursuant thereto to determine if the applicant has been convicted of committing or attempting to commit any of the criminal or drug offenses enumerated above or any other matter which the District finds objectionable. The District has sole discretion for approving or disapproving background checks. Any persons found objectionable by the District will be prevented and/or removed from the school grounds at contractor's expense. Contractor further agrees to submit with said authorization payment for any costs and expenses associated with the criminal background investigation.

Contractor further represents, warrants and certifies that no employee or applicant with respect to whom the criminal investigation reveals any conviction for committing and/or attempting to commit any of the above enumerated offenses, including the Sex Offender Registry Act, and the Statewide Child Murder and Violent Offender Against Youth Database shall be employed thereby in any position that involves or may involve contact with the students of the school District.

**27. WARRANTY**

The Contractor shall provide a warranty for materials and workmanship covering a period of 2 years after final completion and final acceptance of Work. The Warranty shall be against defects due to faulty materials or workmanship and shall agree to replace defective work without cost to Owner. Any deviations or exceptions to this warranty shall be fully detailed. The Contractor shall provide options for optional additional warranty terms and costs associated

**28. GOVERNING LAW AND VENUE**

This Agreement and bid shall be governed by and construed and enforced in accordance with the laws of the State of Illinois, without regard to its conflicts of laws principles. Venue for any action to enforce the terms and conditions of this agreement shall be in the court of competent jurisdiction in Grundy County, Illinois.

**29. SURVIVAL**

The obligations of the Parties contained in this Bid/Agreement which by their nature survive after the term of the Bid/Agreement, such as indemnity, warranties, confidentiality, and audit provisions, shall survive the termination or expiration of this Agreement and continue on indefinitely or as otherwise provided by this Bid/Agreement.

### **30. GENERAL**

The contractor will be responsible for the procurement of all construction permits. The contractor shall give all notices necessary and incident to the due and lawful prosecution of the Work.

A. All work shall be conducted in accordance with the Occupational Safety and Health Administration (OSHA) requirements and Grundy County regulations. The contractor shall be fully responsible for coordination of his work and the work of his employees, subcontractors, and suppliers, and to assure compliance with schedules. The Occupational Safety & Health Administration (OSHA) Hazardous Communication Standard (29 CFR 1910.1200) states that contractors/suppliers must be informed of the hazardous chemicals their employees may be exposed to while performing their work and any appropriate protective measures. In order to comply with this requirement, the District has developed a list of all the hazardous chemicals known to be present in our facility. A Material Safety Data Sheet (MSDS/SDS) is also on file for each of these chemicals and/or hazardous substances. This information is available to you and to your employees upon request.

B. In order to protect the safety and health of our own employees as well as the employees of contractors/suppliers, contractor/suppliers must maintain and provide, upon request, an MSDS/SDS on any hazardous chemical(s) or material(s) which they bring to the facility. Failure to maintain an MSDS/SDS and provide this information in a timely manner will result in the removal of the contractor/supplier from the premises.

C. Each employer is also responsible for notifying any subcontractor they employ regarding the requirements of OSHA's Hazard Communication Standard.

D. The contractor shall schedule work with the authorized District representative with at least Seven (7) days advance notice. The contractor shall at all times conduct the work in such manner as to insure the least obstruction to the school day environment. The convenience and safety of the employees, students, and public shall be provided for in an adequate and satisfactory manner.

E. Any unforeseen site conditions that are encountered in the field that warrant a modification in the plans and/or design shall be brought to the attention of the District's authorized representative.

F. Any construction items that are not represented in the plans or summary of quantities but can be reasonably be expected to be included in the scope of work of an already specified item shall be considered incidental to the Contract and no additional expense shall be permitted.

G. It shall be the sole responsibility of the contractor to restore the project or disturbed areas to conditions prior the commencement of construction activities.

H. To the fullest extent permitted by law, the contractor shall be responsible for any and all injuries or damages to property due to the activities of the contractor, its subcontractors, suppliers, agents and employees arising out of or resulting from performance of the contract, or any activity in connection therewith. The contractor shall indemnify and hold harmless the District, including the Board of Education, its employees, officers and agents from any and all claims, lawsuits, actions, costs and fees, including reasonable attorney's fees and expenses of every nature and description, arising from, growing out of, or connected with the work, or on account of or in consequence of any neglect in safeguarding the work, or on account of or in consequent of using unacceptable materials in construction of the work of because of any act, omission, neglect, or misconduct of contractor, its officers, employees, agents, subcontractors, or anyone directly or indirectly employed by them and/or anyone for whose acts they may be liable for because of any claims or amount of recovered by reason

of any infringement of patent, trademark, or copyright, or by reason of the violation of any law, ordinance, order, or decree.

I. The contractor shall be responsible for meeting any requirement for any machine, device or part thereof, which is regulated by or becomes regulated by Federal or State of Illinois Noise Standards, shall conform to those standards. All other equipment shall operate under the noise requirements of the County of Grundy, IL.

J. The contractor acknowledges by signing and submitting this invitation to bid that the contractor agrees with the terms herein and acknowledges to be bound by said terms. The terms of this invitation to bid shall be incorporated into any subsequent contract between the parties and shall take precedence over any contradicting terms. Nothing in this bid/contract between the District and the contractor or anyone else is intended or shall be construed, unless otherwise expressly stated, to reduce the responsibility of the contractor, subcontractor, anyone directly or indirectly employed by them or anyone for whose acts they may be liable, from full and complete supervision and achievement of work place safety.

K. Any inspection of the work conducted by an authorized representative of the District, employee, or officer whether notice of the results thereof is provided to anyone or not provided to anyone, shall neither establish any duty on their parts nor create any expectation of duty to anyone, including but not limited to third parties, regarding work place safety. In order to insure this and other duties of the contractor, certain indemnifications and insure is required by the contract. Additionally, the contractor guarantees to the owner a safe work place shall be provided for all employees of the contractor, subcontractor, anyone directly or indirectly employed by them or anyone for whose acts they may be liable of the applicable standards of the Occupational Safety and Health Act and any work place safety act of the State of Illinois. Contractor agrees to require this work place safety guarantee of all subcontractors and expressly require the District and Board of Education to be third party beneficiaries of each guarantee.

L. Working Hours Unless authorization for extended hours has been obtained in writing from Engineer, or is specifically provided for within these specifications, Contractor shall restrict his working operations to the hours between 6:00 o'clock a.m. and 5:00 o'clock p.m., Monday through Saturday. These restrictions shall not apply to the maintenance or operation of any and all safety and traffic control devices which are required to remain in place during non-working hours, or to work of an emergency nature.

M. Occupation and Use of Work Site Contractor shall: a.) Confine operations at the Work Site to areas permitted by law, ordinances, permits, and the Contract Documents. b.) Not load or permit any part of a structure to be subjected to any force that will endanger its safety. c.) Comply with and enforce Owner's instructions regarding signs, advertisements, fires, and smoke. d.) Assume responsibility for protection and safekeeping of equipment, materials, or products stored at the Work Site. e.) Not discharge smoke, dust, or other contaminants into the atmosphere, or fluids or materials into any waterway as will violate regulations of any legally constituted authority. f.) At all times keep the Work Site free from accumulating waste materials and rubbish caused by his work or employees. All materials and equipment required on the site shall be kept in such a manner so as to cause a minimum of inconvenience and nuisance to other Contractors and the general public. g.) Move stored materials or products which interfere with the operations of Owner or other Contractors, or impede the safe movement of vehicular traffic or pedestrians. h.) Obtain and pay for additional storage or work areas needed for operations. i.) Not permit the consumption of alcohol, illegal drug use, smoking, and vaping at the Work Site.

N. Protection of Existing Drainage Facilities and Water System Appurtenances During Construction Whenever during construction operations any loose material is deposited in the flow line of gutters, drainage structures, or ditches such that the natural flow line of water is obstructed, this loose material shall be removed at the close of each working day. At the conclusion of construction operations all drainage structures and flow

lines shall be free from dirt and debris. This work shall be considered incidental to the contract, and no additional compensation will be allowed.

O. Unless reconstruction or adjustment of an existing manhole, catch basin, inlet or adjustment to the frame and grate of the aforementioned structure is called for or is ordered by Engineer, the proposed work should meet the existing elevations of these structures. Contractor shall take the necessary precautions when working near or above existing sewers to protect these sewers from any damage resulting from his operations.

P. Co-operation with Utilities Contractor shall notify all utilities utilizing the JULIE One-Call system at least 48 hours prior to commencement of any construction. Underground utilities may not be shown on the Plans. Contractor shall be responsible to determine the existence, nature and location of all utilities and appurtenances. Contractor shall exercise all reasonable precautions against damage to existing utilities. The operation of existing utilities shall not be interrupted as a routine part of Contractor's operation. In the event of an interruption of any utility, Contractor shall be responsible for identifying the appropriate utility and shall lend all possible assistance in restoring service. Contractor shall assume all costs connected with the repair of any damaged utility. Where the location of utilities interferes with the proposed Work to the extent that the Drawings must be altered, Owner shall be notified so that appropriate changes can be implemented. Contractor shall cooperate with the Owner and all utility companies involved with the removal, temporary relocation, reconstruction, or abandonment by these agencies of any and all services or facilities owned or operated by them within the limits of this improvement. Costs associated with bracing, identifying, protecting or moving any facility shall be considered incidental to the Contract

Q. Protection of Trees, Shrubs, and Grass Every effort shall be made by Contractor when working near trees, shrubs, and grass to preserve same from harm. Contractor shall be responsible for damage to or loss of any tree, shrub, and grass and shall replace and or repair any damage and return it to the same condition or better.

R. Cleanup and Restoration Contractor shall prepare and clean up all loose concrete and rubble, excavated materials, forms, tools and any other miscellaneous debris as soon as work is completed at construction site.

R. Dust Control At the end of each day's operations, or as required by Owner, Contractor shall take appropriate measures to control dust throughout the project limits. The cost for dust control shall be considered incidental to the Contract, and no additional compensation will be made.

S. Contractor shall, during the duration of the project, maintain an emergency phone number where a contact person can be notified at any time, weekends and holidays included, of an emergency condition due to the work which requires immediate repair or protection.

**Minooka Community High School District 111**  
**26655 W. Eames Street**  
**Channahon, IL 60410**

**SPECIFICATIONS**

**PURPOSE**

It will be the bidder's sole responsibility to be all inclusive with labor, material and equipment necessary to replace the cooling tower at the Minooka Community High School District 111, South Campus.

**DESCRIPTION AND IMPROVEMENTS**

**A. Cooling tower**

- a. The following equipment is a list of items the School District believes needs to be replaced, and shall be done in a manner that complies with current local building codes:
  - i. Cooling tower replaced
  - ii. Piping from cooling tower to piping on the exterior wall.
  - iii. Pipe insulation
  - iv. Anything else pertaining to this project that is deficient or required for safe operation all of which will be detailed in the quote.
- c. The new unit shall be of comparable brand and model or better than the existing unit.
- d. The new unit shall be of comparable ratings and tons of cooling. Exceptions shall be explained in detail. **Contractor shall provide the School District with a side-by-side comparison of specifications of the current unit and the unit being installed.**
- e. The existing unit is a Marley NC Class, serial number 818648-A2-NC8305CB-07 (see pictures).
- f. The new cooling tower shall be **stainless steel casing, structure, and basins.**
- g. Piping, valves, and disconnects shall be prominently labeled.
- h. The cooling tower shall have a variable frequency Drive (VFD) system included.
- i. The cooling tower shall have liquid alarms for Makeup, High Alarm, and Low Alarm with feedback to the BAS.
- j. Furnish and install the following:

**Mechanical:**

- i. Demo and install new cooling tower
- ii. install all shipped loose items such as ladder, handrails, fan guards, etc. (caged ladder, handrails, and fan guards are required as per original unit)
- iii. fabricate and install approx. 100 ft of 8" cs sch 40 pipe with grooved ends
- iv. fabricate and install approx. 60 feet of 6" cs sch 40 pipe with grooved ends
- v. fabricate and install approx. 20 ft of 10" cs 40 pipe with grooved ends
- vi. furnish and install all required vic clamps with gaskets (water service)
- vii. furnish and install 10' equalization line including drain valve
- viii. furnish and install water make up line using pro-press copper
- ix. furnish and install overflow drain using pvc schedule 40 pipe.
- x. Install new cooling tower and all loose shipped items, ( i.e. handrails, fan guards, etc.)
- xi. all piping to wire brushed and solvent cleaned. Roller apply one (1) coat PPG's Amerlock 2 epoxy and two coats of PPG's durethane. All painting to be completed after installation of piping.

**Electrical**

- i. Demolition of conduits and wiring supported to existing tower.

- ii. cooling tower motor disconnects
- iii. Pull wire and cable back to junction boxes located inside building
- iv. Two (2) new NEM 3R 60 amp disconnects
- v. Two (2) motor disconnects
- vi. Six (6) instrument connections
- vii. All new rigid conduit, fittings, and wire
- viii. all terminations, testing and labels

**B. Roof Structure & Supports**

- a. Contractor to inspect existing roof structure and supports to determine suitability and include in quote any necessary infrastructure improvements necessary.
- b. Contractor to inspect the existing supports and I-Beams to determine suitability and include in quote any necessary infrastructure improvements necessary. Supports must be level prior to installation.
- c. Any damage caused to the roof structure during the installation of the cooling tower shall be repaired by the contractor at their cost and by a licensed roofing contractor.

**C. Demolition & Installation**

- a. Demolition and installation shall be coordinated with School District. It is anticipated that this work will occur while the building is occupied. Contractor to coordinate all staging, craning, and demolition work in a manner to ensure safety and well-being of students and staff.
- b. Any and all work shown to be carried out in accordance with all governing federal, state, and local codes, including OSHA.
- c. Contractor to shore and support any existing construction to remain until all new construction and imposed loads are in place.
- d. Anything removed that can be recycled shall be recycled.
- e. All removed equipment must be disposed of by contractor
- f. all lifts and cranes to be supplied by contractor.
- g. The unit shall be completely installed no later than November 1, 2024

**D. Testing, Commissioning, Water Treatment**

- a. Testing and commissioning to be conducted by contractor. The contractor must submit a comprehensive testing and commissioning plan with checkoff lists. This testing and commissioning plan shall ensure that the unit once turned over to the School District complies with the operational needs of the School District and the manufacturers design and installation specifications.
- b. Contractor will review and document whether the District's current water treatment system is compatible with the operation of the cooling tower and appropriate in accordance with the cooling tower manufacturer instructions and warranty. If changes to the District's water treatment system are necessary contractor shall promptly notify the District.

**E. Training & Documentation**

- a. Supply District training for proper use and maintenance of all new equipment including winterization.
- b. Provide owner with operation and service manuals for all new installed equipment including "as-built" drawings.

**E. Warranty**

- a. The contractor shall provide complete details of the warranty as required by terms of RFP included with the price as well as the cost for additional/extended warranties as an Add-On.















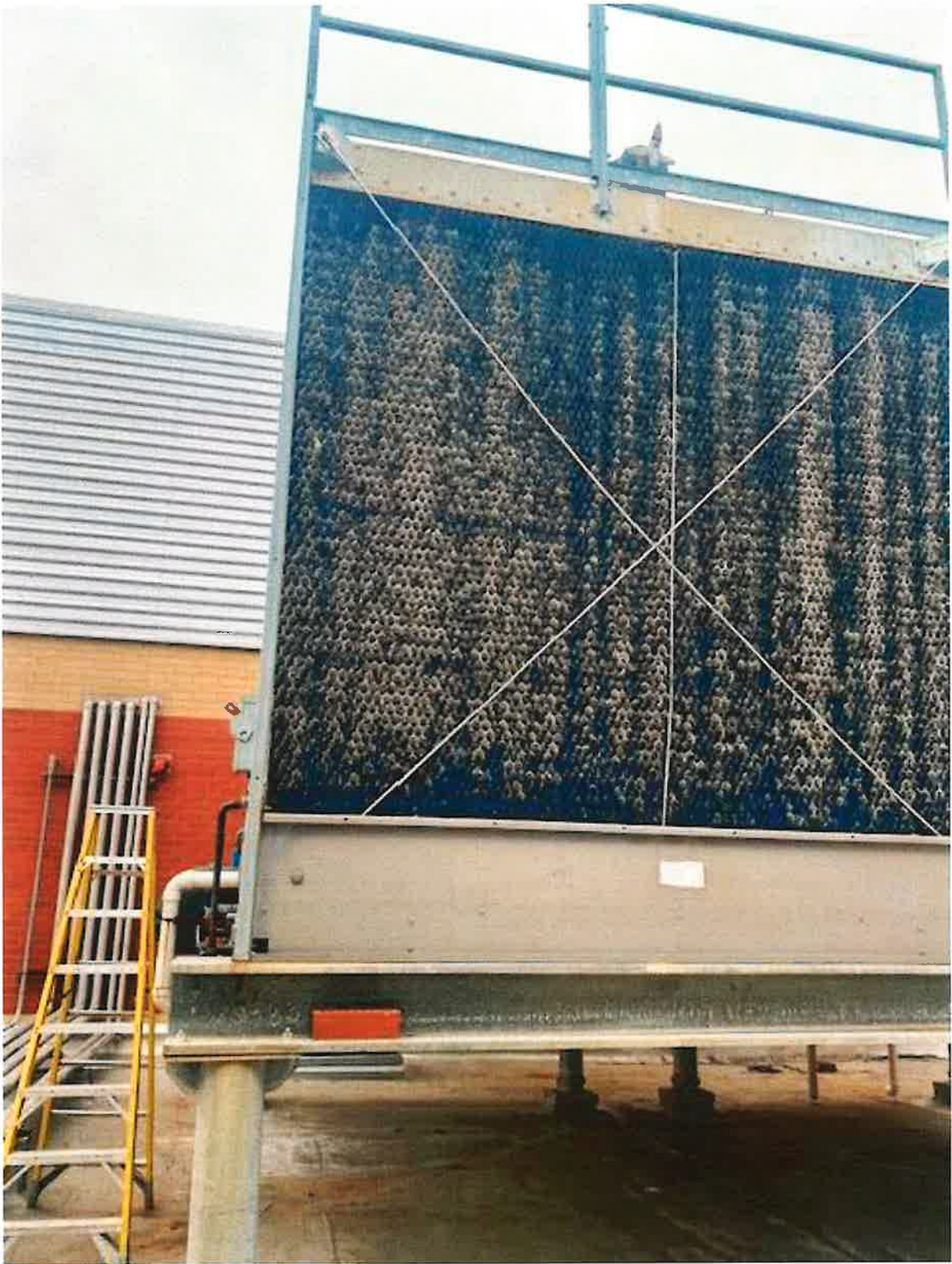



**Minooka Community High School District 111**

26655 W. Eames Street  
Channahon, IL 60410

# Assurances and Certifications PART 1

## STATEMENT OF ETHICS CERTIFICATION

By submission of this bid or proposal, the bidder certifies that:

1. This bid or proposal has been independently arrived at without collusion with any other bidder or with any competitor.
2. This bid or proposal has not been knowingly disclosed and will not be knowingly disclosed, prior to the opening of bids or proposals for this project, to any other bidder, competitor or potential competitor.
3. No attempt has been made or will be made to induce any other person, partnership or corporation to submit or not to submit a bid or proposal.
4. Bidder has not been convicted of price fixing nor pleaded "no contest" to such charges within the last five (5) years.
5. Bidder is not subsidiary of a company that has been convicted of price fixing nor pleaded "no contest" to such charges within the last five (5) years.

By: *Tracy Mainz*  
Authorized Agent

SUBSCRIBED and SWORN TO before me

this 11<sup>th</sup> day of April, 20 24

*Steven C Franz*  
NOTARY PUBLIC



This page must be returned signed and notarized for the bid to be considered.

**Minooka Community High School District 111**

26655 W. Eames Street  
Channahon, IL 60410

## Assurances and Certifications PART 2

### SUPPLIER'S/CONTRACTOR'S CERTIFICATION

As part of its bid, the supplier/contractor does hereby certify that said supplier/contractor is not barred from bidding on the contract as a result of violation of either Section 33E-3 or 33E-4 of Article 33E of Chapter 38 of the Illinois Revised Statutes.

By: Christy Maria  
Authorized Agent

### CERTIFICATE OF COMPLIANCE WITH ILLINOIS DRUG-FREE WORKPLACE ACT (Suppliers/Contractors with 25 or More Employees)

As part of its bid, the supplier/contractor does hereby certify pursuant to section 3 of the *Illinois Drug-Free Workplace Act* (Ill.Rev.Stat. ch 127, para. 132.313) that [he, she, it] shall provide a drug-free workplace for all employees engaged in the performance or work under the contract by complying with the requirements of the *Illinois Drug-Free Workplace Act* and, further certifies, that [he, she, it] is not ineligible for award of this contract by reason of debarment for a violation of the *Illinois Drug-Free Workplace Act*.

By: Christy Maria  
Authorized Agent

Does Not Apply (Less than 25 Employees)

By: Christy Maria  
Authorized Agent

SUBSCRIBED and SWORN TO before me

this 11<sup>th</sup> day of April, 20 24

Steven C Franz  
NOTARY PUBLIC



This page must be returned signed and notarized for the bid to be considered.

Minooka Community High School District 111  
26655 W. Eames Street  
Channahon, IL 60410

## Assurances and Certifications PART 3

### CERTIFICATE OF COMPLIANCE WITH ILLINOIS HUMAN RIGHTS ACT

#### Sexual Harassment Policies

As part of its bid, the supplier/contractor does hereby certify pursuant to 775 ILCS 5/2-105 that [he, she, it] has written sexual harassment policies that include at least the minimum information as required by law; that a copy of the policies shall be provided to the Department of Human Rights upon request; and that [he, she, it] is not ineligible for award of this contract by reason of debarment for a violation of the *Illinois Human Rights Act*.

By:   
Authorized Agent

#### Equal Employment Opportunity

As part of its bid, the supplier/contractor does hereby certify pursuant to 775 ILCS 5/2-104 that [he, she, it] complies with the procedures and requirement of the Illinois Department of Human Rights regulations concerning equal employment opportunities and affirmative action, shall provide such information with respect to its employees and applicants for employment and assistance as the Department may reasonably request, and that [he, she, it] is not ineligible for award of this contract by reason of debarment for a violation of the *Illinois Human Rights Act*.

By:   
Authorized Agent

SUBSCRIBED and SWORN TO before me

this 11<sup>th</sup> day of April, 20 24

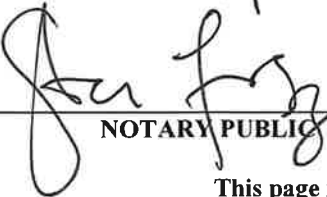
  
NOTARY PUBLIC



This page must be returned signed and notarized for the bid to be considered.

Minooka Community High School District 111  
26655 W. Eames Street  
Channahon, IL 60410

# Assurances and Certifications PART 4

AGREEMENT TO BE BOUND BY THE TERMS OF THE BID

If the contract is awarded to the contractor, the contractor hereby adopts, accepts, and agrees to be bound by all the terms and conditions of the MINOOKA COMMUNITY HIGH SCHOOL DISTRICT 111 WATER COOLING TOWER REPLACEMENT bid.

By: Quincy Murray  
Authorized Agent

Equal Employment Opportunity

SUBSCRIBED and SWORN TO before me

this 11<sup>th</sup> day of April, 2024

Steven C Franz  
NOTARY PUBLIC



This page must be returned signed and notarized for the bid to be considered.



# ESTIMATE

4632 W. Lawrence Avenue  
Chicago, IL 60630

DATE	ESTIMATE #
4/11/2024	65965

CUSTOMER
Minooka Community High School District 111 2665 W. Eames Street Channahon, IL 60410

PROJECT ADDRESS
Minooka Community High School District 111 2665 W. Eames Street Channahon, IL 60410

Thank you for allowing Core Mechanical, Inc., the opportunity to bid on your current job. We will always provide you with the best quality and service as possible!

LOCATION
Water Cooling Tower Replacement

DESCRIPTION	PRICE
SCOPE OF WORK - WATER COOLING TOWER REPLACEMENT - BASE BID - Perform the Work Provided in the Specifications Provided by Minooka Community High School District 111 for the Cooling Tower Replacement Project.  NOTE: 23 - 24 WEEK LEAD TIME ON EQUIPMENT	543,725.00

Thank you for your business!	<b>TOTAL</b>	\$543,725.00
------------------------------	--------------	--------------



# ESTIMATE

4632 W. Lawrence Avenue  
Chicago, IL 60630

DATE	ESTIMATE #
4/11/2024	65966

CUSTOMER
Minooka Community High School District 111 2665 W. Eames Street Channahon, IL 60410

PROJECT ADDRESS
Minooka Community High School District 111 2665 W. Eames Street Channahon, IL 60410

Thank you for allowing Core Mechanical, Inc., the opportunity to bid on your current job. We will always provide you with the best quality and service as possible!

LOCATION
Water Cooling Tower Replacement

DESCRIPTION	PRICE
SCOPE OF WORK - WATER COOLING TOWER REPLACEMENT - ADDITIONAL LABOR WARRANTY - Provide the SPX Cooling Tech, LLC Certification of Limited Warranty (Warranty Certificate) 5 Year Labor Warranty.	14,795.00

<i>Thank you for your business!</i>	<b>TOTAL</b>	<b>\$14,795.00</b>
-------------------------------------	--------------	--------------------

**Proposal For:**  
Minooka C.H.S.D. 111  
26655 W. Eames Street  
Channahon, IL

**Deliver To:**  
Minooka H.S. - Central Campus  
301 S. Wabena Avenue  
Minooka, IL

MARK	LOCATION	Product Type	Manufacturer	Series	Product	Model #	QTY	\$/Unit	Extended Price	Finish 1	Finish 2	Finish 3	Finish 4	Finish 5	Finish 6	Finish 7	Finish 8	NOTES
FN-1	Registrar's Office (Rm# B3)	Guest Chair	HON	Ignition	Multipurpose Chair	HIGS6	6	\$264.50	\$1,587.00	Mesh: Black	Seat Fabric: Grade 3 - Moxie - Tangerine	Arms & Legs: Black						Same specs as the Admin
FN-2A	Registrar's Office (Rm# B3)	Guest Table	HON	Arrange	36" Table Top	HCTRND36	1	\$184.40	\$184.40	Laminate: Silver Mesh (B9V)	Edge Band: Loft (LOFT)							Same specs as the Admin
FN-2B	Registrar's Office (Rm# B3)	Guest Table	HON	Arrange	X-Base	HCT29MX	1	\$264.40	\$264.40	Base: Textured Platinum Metallic (PLAT)								Same specs as the Admin
FN-3A	Registrar's Office (Rm# B3)	Lateral File	HON	Brigade 800	3-drawer lateral, 36"W	H883	6	\$658.70	\$3,952.20	Paint: Loft								
FN-3A.1	Registrar's Office (Rm# B3)	Lateral File	HON	Brigade 800	Front to back filing rails	H919491	9	\$35.50	\$319.50									
	Registrar's Office (Rm# B3)	Lateral File	HON		Key Core	HF23S.X101	6	\$17.80	\$106.80									
FN-3B	Registrar's Office (Rm# B3)	Lateral File Top	HON		Laminate Top, 36"W x 36"D	HSISLAUTPNB3636S1	3	\$303.80	\$911.40	Laminate: Silver Mesh (B9V)	Edge Band: Loft (LOFT)							
FN-4	Registrar's Office (Rm# B3)	Lateral File	HON	Brigade 800	4-drawer	H884	6	\$811.50	\$4,869.00	Paint: Loft								
FN-4.1	Registrar's Office (Rm# B3)	Lateral File	HON	Brigade 800	Front to back filing rails	H919491	12	\$35.50	\$426.00									
	Registrar's Office (Rm# B3)	Lateral File	HON		Key Core	HF23S.X102	4	\$17.80	\$71.20									
FN-5A	Registrar's Office (Rm# B3)	L-Desk	HON	10500 Series	72"x36" Rectangle Shell, 2 grommets	H10594	2	\$390.90	\$781.80	Laminate: Pinnacle (PINC)	Edge Band: Pinnacle (PINC)							
FN-5B	Registrar's Office (Rm# B3)	L-Desk Return	HON	10500 Series	48"W x24"D Return, 1 grommet	H10561	2	\$254.10	\$508.20	Laminate: Pinnacle (PINC)	Edge Band: Pinnacle (PINC)							
h	Registrar's Office (Rm# B3)	BBF Pedestal	HON	10500 Series	15.75"W x 22.75"D x 28.24"H, Mobile	H105102	2	\$414.00	\$828.00	Laminate: Pinnacle (PINC)	Edge Band: Pinnacle (PINC)							Same specs as the Admin
FN-7	Registrar's Office (Rm# B3)	FF Pedestal	HON	10500 Series	15.75"W x 22.75"D x 28.24"H, Mobile	H105104	2	\$414.00	\$828.00	Laminate: Pinnacle (PINC)	Edge Band: Pinnacle (PINC)							Same specs as the Admin
	Registrar's Office (Rm# B3)	L-Desk	HON		Key Core	HF23S.X103	3	\$17.80	\$53.40									
	Registrar's Office (Rm# B3)	L-Desk	HON		Key Core	HF23S.X104	3	\$17.80	\$53.40									360
FN-8	Conference Room (Rm# 261C)	Meeting Chair	HON	Ignition 2	Task Chair	HITLM	8	\$326.70	\$2,613.60	Mesh: Black	Seat Fabric: Grade 3 - Moxie - Terracotta	Arms & Legs: Black						Same specs as the other task chairs
FN-9	Conference Room (Rm# 261C)	Credenza	HON	Preside	72" W x 20"D x 36"H, No refrigeration	HTLCRED72S	1	\$1,365.80	\$1,365.80	Laminate: Pinnacle (PINC)	Edge Band: Pinnacle (PINC)							Same specs as the Admin
FN-10A	Conference Room (Rm# 261C)	Meeting Table Top	HON	Preside	108"W x 48"D x 29.5"H, Boat Shape top	HTL(B)48108	1	\$527.70	\$527.70	Laminate: Pinnacle (PINC)	Edge Band: Pinnacle (PINC)							
FN-10B	Conference Room (Rm# 261C)	Meeting Table Base	HON	Preside	Y-Base	HT29FB48108	1	\$750.10	\$750.10	Base: Textured Platinum Metallic (PLAM)								
FN-10C	Conference Room (Rm# 261C)	Meeting Table Base	HON	Preside	Power Module	HTG1PWR-3P-1B	2	\$187.60	\$375.20									Same specs as the Admin
FN-5A	Reception room (Rm# 261)	L-Desk	HON	10500 Series	72"x36" Rectangle Shell, 2 grommets	H10594	1	\$390.90	\$390.90	Laminate: Pinnacle (PINC)	Edge Band: Pinnacle (PINC)							
FN-5B	Reception room (Rm# 261)	L-Desk Return	HON	10500 Series	48"W x24"D Return, 1 grommet	H10561	1	\$254.10	\$254.10	Laminate: Pinnacle (PINC)	Edge Band: Pinnacle (PINC)							
FN-6	Reception room (Rm# 261)	BBF Pedestal	HON	10500 Series	15.75"W x 22.75"D x 28.24"H, Mobile	H105102	1	\$414.00	\$414.00	Laminate: Pinnacle (PINC)	Edge Band: Pinnacle (PINC)							Same specs as the Admin
FN-7	Reception room (Rm# 261)	FF Pedestal	HON	10500 Series	15.75"W x 22.75"D x 28.24"H, Mobile	H105104	1	\$414.00	\$414.00	Laminate: Pinnacle (PINC)	Edge Band: Pinnacle (PINC)							Same specs as the Admin
	Reception room (Rm# 261)	L-Desk	HON		Key Core	HF23S.X105	2	\$17.80	\$35.60									
FN-11	Reception room (Rm# 261)	Sofa	Global	River +	3-seat, High Back, with Arms, No clean-out channel	R27808B	1	\$5,093.30	\$5,093.30	Back Fabric: GRADE 10 - Arc Com - Apex - Tangerine	Arm Fabric: GRADE 10 - Arc Com - Apex - Tangerine	Seat Fabric: GRADE 5 - Stinson Tessuto Strada	Leg: Tungsten (ITU)					
FN-1	Reception room (Rm# 261)	Guest Chair	HON	Ignition	Multipurpose Chair	HIGS6	4	\$264.50	\$1,058.00	Mesh: Black	Seat Fabric: Grade 3 - Moxie - Tangerine	Arms & Legs: Black						Same specs as the Admin
FN-2A	Reception room (Rm# 261)	Guest Table	HON	Arrange	36" Table Top	HCTRND36	1	\$184.40	\$184.40	Laminate: Silver Mesh (B9V)	Edge Band: Loft (LOFT)							Same specs as the Admin
FN-2B	Reception room (Rm# 261)	Guest Table	HON	Arrange	X-Base	HCT29MX	1	\$264.40	\$264.40	Base: Textured Platinum Metallic (PLAM)								Same specs as the Admin
FN-12.1	Reception room (Rm# 261)	Bookcase	HON	10500 Series	3-shelf, 36"W x13"D x 43.3"H	H105533	1	\$292.10	\$292.10	Laminate: Pinnacle (PINC)	Edge Band: Pinnacle (PINC)							
FN-12.2	Athletic Director (Rm# 261B)	Bookcase	HON	10500 Series	5-shelf, 36"W x13"D x 71"H	H105535	1	\$399.40	\$399.40	Laminate: Pinnacle (PINC)	Edge Band: Pinnacle (PINC)							Same specs as the Admin
FN-13	Athletic Director (Rm# 261B)	Wardrobe	HON	10500 Series	Left-Handed, 18"W x 24"D x 66.625"H	H105296L	1	\$741.50	\$741.50	Laminate: Pinnacle (PINC)	Edge Band: Pinnacle (PINC)	Lock: Silver						Same specs as the Admin
FN-1	Athletic Director (Rm# 261B)	Guest Chair	HON	Ignition	Multipurpose Chair	HIGS6	3	\$264.50	\$793.50	Mesh: Black	Seat Fabric: Grade 3 - Moxie - Tangerine							Same specs as the Admin
FN-2A	Athletic Director (Rm# 261B)	Guest Table	HON	Arrange	36" Table Top	HCTRND36	1	\$184.40	\$184.40	Laminate: Silver Mesh (B9V)	Edge Band: Loft (LOFT)							Same specs as the Admin
FN-2B	Athletic Director (Rm# 261B)	Guest Table	HON	Arrange	X-Base	HCT29MX	1	\$264.40	\$264.40	Base: Textured Platinum Metallic (PLAT)								Same specs as the Admin
FN-14A	Athletic Director (Rm# 261B)	U-Desk	HON	10500 Series	72"W x 36"D x 29"H Rectangle Desk Shell, 2 grommets	H10594	1	\$390.90	\$390.90	Laminate: Pinnacle (PINC)	Edge Band: Pinnacle (PINC)							Same specs as the Admin
FN-14B	Athletic Director (Rm# 261B)	U-Desk Bridge	HON	10500 Series	48"W x 24"D Bridge	H10570	1	\$177.20	\$177.20	Laminate: Pinnacle (PINC)	Edge Band: Pinnacle (PINC)							Same specs as the Admin
FN-14C	Athletic Director (Rm# 261B)	U-Desk Credenza	HON	10500 Series	72"W x 24"D x 29"H Rectangle Desk Shell, 10" modesty panel, grommets	H10541X	1	\$337.10	\$337.10	Laminate: Pinnacle (PINC)	Edge Band: Pinnacle (PINC)							Same specs as the Admin
FN-6	Athletic Director (Rm# 261B)	BBF Pedestal	HON	10500 Series	15.75"W x 22.75"D x 28.24"H, Mobile	H105102	1	\$414.00	\$414.00	Laminate: Pinnacle (PINC)	Edge Band: Pinnacle (PINC)							Same specs as the Admin
FN-7	Athletic Director (Rm# 261B)	FF Pedestal	HON	10500 Series	15.75"W x 22.75"D x 28.24"H, Mobile	H105104	1	\$414.00	\$414.00	Laminate: Pinnacle (PINC)	Edge Band: Pinnacle (PINC)							Same specs as the Admin

MARK	LOCATION	Product Type	Manufacturer	Series	Product	Model #	QTY	\$/Unit	Extended Price	Finish 1	Finish 2	Finish 3	Finish 4	Finish 5	Finish 6	Finish 7	Finish 8	NOTES
	Athletic Director (Rm# 261B)	U-Desk	HON		Key Core	HF23S.X106	3	\$17.80	\$53.40									
FN-12.2	Activity Director (Rm# 261A)	Bookcase	HON	10500 Series	5-shelf, 36"W x 13"D x 71"H	H105535	1	\$399.40	\$399.40	Laminate: Pinnacle (PINC)	Edge Band: Pinnacle (PINC)							Same specs as the Admin
FN-13	Activity Director (Rm# 261A)	Wardrobe	HON	10500 Series	Left-Handed, 18"W x 24"D x 66.625"H	H105296L	1	\$741.50	\$741.50	Laminate: Pinnacle (PINC)	Edge Band: Pinnacle (PINC)	Lock: Silver						Same specs as the Admin
FN-1	Activity Director (Rm# 261A)	Guest Chair	HON	Ignition	Multipurpose Chair	HIGS6	3	\$264.50	\$793.50	Mesh: Black	Seat Fabric: Grade 3 - Moxie - Tangerine							Same specs as the Admin
FN-2A	Activity Director (Rm# 261A)	Guest Table	HON	Arrange	36" Table Top	HCTRND36	1	\$184.40	\$184.40	Laminate: Silver Mesh (B9V)	Edge Band: Loft (LOFT)							Same specs as the Admin
FN-2B	Activity Director (Rm# 261A)	Guest Table	HON	Arrange	X-Base	HCT29MX	1	\$264.40	\$264.40	Base: Textured Platinum Metallic (PLAM)								Same specs as the Admin
FN-14A	Activity Director (Rm# 261A)	U-Desk	HON	10500 Series	72"W x 36"D x 29"H Rectangle Desk Shell, 2 grommets	H10594	1	\$390.90	\$390.90	Laminate: Pinnacle (PINC)	Edge Band: Pinnacle (PINC)							Same specs as the Admin
FN-14B	Activity Director (Rm# 261A)	U-Desk Bridge	HON	10500 Series	48"W x 24"D Bridge	H10570	1	\$177.20	\$177.20	Laminate: Pinnacle (PINC)	Edge Band: Pinnacle (PINC)							Same specs as the Admin
FN-14C	Activity Director (Rm# 261A)	U-Desk Credenza	HON	10500 Series	72"W x 24"D x 29"H Rectangle Desk Shell, 10" modesty panel, grommets	H10541X	1	\$337.10	\$337.10	Laminate: Pinnacle (PINC)	Edge Band: Pinnacle (PINC)							Same specs as the Admin
FN-6	Activity Director (Rm# 261A)	BBF Pedestal	HON	10500 Series	15.75"W x 22.75"D x 28.24"H, Mobile	H105102	1	\$414.00	\$414.00	Laminate: Pinnacle (PINC)	Edge Band: Pinnacle (PINC)							Same specs as the Admin
FN-7	Activity Director (Rm# 261A)	FF Pedestal	HON	10500 Series	15.75"W x 22.75"D x 28.24"H, Mobile	H105104	1	\$414.00	\$414.00	Laminate: Pinnacle (PINC)	Edge Band: Pinnacle (PINC)							Same specs as the Admin
	Activity Director (Rm# 261A)	U-Desk	HON		Key Core	HF23S.X107	3	\$17.80	\$53.40									
FN-15A	Conference Room (Rm# 263)	Group Table	HON	Huddle	72"W x 30"D Table Top	HMT3072G	6	\$239.30	\$1,435.80	Laminate: Silver Mesh (B9V)	Edge Band: Loft (LOFT)							Same specs as the Admin
FN-15B	Conference Room (Rm# 263)	Group Table	HON	Huddle	29"H Table Base, Mobile, Flip & Nest	HMBFLIP30L	6	\$334.40	\$2,006.40	Base: Platinum Metallic (T1)								Same specs as the Admin
FN-16	Conference Room (Rm# 263)	Chairs	HON	Motivate	Armless (N), With All Surface Casters (S)	HMG1	36	\$143.20	\$5,155.20	Seat Shell: Lava	Base: Textured Platinum Metallic (PLAT)							
FN-17	Conference Room (Rm# 263)	Lectern	Moore Co	Avid		91198	1	\$821.50	\$821.50	Laminate: Fusion Maple	Edge Band: Gray	Base: Standard Silver						Same specs as the Admin
FN-18A	PE Office (Rm# 432)	Desk	HON	10500 Series	72"W x 30"D Table Top, no modesty panel	H105R3072	4	\$195.30	\$781.20	Laminate: Silver Mesh (B9V)	Edge Band: Loft (LOFT)							
FN-18B	PE Office (Rm# 432)	Desk	HON	10500 Series	O-Leg	HLSL3028O	8	\$191.80	\$1,534.40	Base: Textured Platinum Metallic (PLAT)								
FN-19	PE Office (Rm# 432)	BBF Pedestal	HON	Brigade 800	15"W x 22.75"D x 28"H, Mobile	H33723R	4	\$242.40	\$969.60	Paint: Loft								
FN-20	PE Office (Rm# 432)	FF Pedestal	HON	Brigade 800	15"W x 22.75"D x 28"H, Mobile	H33823R	4	\$242.40	\$969.60	Paint: Loft								
	PE Office (Rm# 432)	Desk	HON		Key Core	HF23S.X108	2	\$17.80	\$35.60									
	PE Office (Rm# 432)	Desk	HON		Key Core	HF23S.X109	2	\$17.80	\$35.60									
	PE Office (Rm# 432)	Desk	HON		Key Core	HF23S.X110	2	\$17.80	\$35.60									
	PE Office (Rm# 432)	Desk	HON		Key Core	HF23S.X111	2	\$17.80	\$35.60									
FN-21A	Trainers Room (Rm# 459)	Treatment Table	Proteam	Pro-Options	<a href="https://www.hausmann.com/product/proteam-pro-options-table/">https://www.hausmann.com/product/proteam-pro-options-table/</a>		1	NO BID	NO BID	Laminate: Slate Gray (L08)	Vinyl Color: Black (V23)	Cabinet Style (CAB): Access Both Sides (A9075)	Top Style (TOP): Gas Spring Backrest with Split Leg (A61 and A69)	Head Unit (COMP1): Left/Right Double Doors with wire handle (1-A62-WIRE)	Middle Unit (COMP2): Left/Right Open Shelf (2-OPEN)	Foot Unit (COMP3): Right 2 Drawers with wire handle (3-A65-WIRE)	Locks (LOCKS): No Locks (NOLOCKS)	CUSTOM LOGO: TBD
FN-21B	Trainers Room (Rm# 459)	Treatment Table	Proteam	Pro-Options	<a href="https://www.hausmann.com/product/proteam-pro-options-table/">https://www.hausmann.com/product/proteam-pro-options-table/</a>		1	NO BID	NO BID	Laminate: Slate Gray (L08)	Vinyl Color: Black (V23)	Cabinet Style (CAB): Access Both Sides (A9075)	Top Style (TOP): Gas Spring Backrest with Split Leg (A61 and A69)	Head Unit (COMP1): Left/Right Double Doors with wire handle (1-A62-WIRE)	Middle Unit (COMP2): Left/Right Modality Drawer (2-A64)	Foot Unit (COMP3): Right 2 Drawers with wire handle (3-A65-WIRE)	Locks (LOCKS): No Locks (NOLOCKS)	CUSTOM LOGO: TBD
FN-22	Trainers Room (Rm# 459)	Hi-Lo Table	Proteam	Hi-Lo Extra Long Trainers Table	<a href="https://www.hausmann.com/product/hi-lo-extra-long-trainers-table/">https://www.hausmann.com/product/hi-lo-extra-long-trainers-table/</a>		1	NO BID	NO BID	Laminate: Slate Gray (L08)	Vinyl Color: Black (V23)							CUSTOM LOGO: TBD
FN-23	Trainers Room (Rm# 459)	Taping Station	Proteam	Modular Taping Stations	<a href="https://www.hausmann.com/product/custom-modular-taping-stations/">https://www.hausmann.com/product/custom-modular-taping-stations/</a>		1	NO BID	NO BID	Laminate: Slate Gray (L08), Vinyl Color: Black (V23)	SEATS: 3 Seats (SEATS3), Height: 42" (H42), Depth: 42" (D42)	Seat 1 Front: Extra Drawer (SEAT1-Front-A14), Backrest: Fixed 75 degree Upholstered back (SEAT1-A26)	Storage 1 Front: Standard (STORE1-FRONT-STANDARD), Top: Waste Hamper (STORE1-TOP-A24)	Seat 2 Front: Extra Drawer (SEAT2-Front-A14), Backrest: Fixed 75 degree Upholstered back (SEAT2-A26)	Storage 2 Front: Standard (STORE2-FRONT-STANDARD), Top: Waste Hamper (STORE2-TOP-A24)	Seat 3 Front: Extra Drawer (SEAT3-Front-A14), Backrest: Fixed 75 degree Upholstered back (SEAT3-A26)	Side Right: Standard (SIDEL-STANDARD)	CUSTOM LOGO: TBD
FN-24	Trainers Room (Rm# 459)	Stools	Proform	Heavy-Duty Air-Lift Stool with Control Handle	<a href="https://www.hausmann.com/product/heavy-duty-air-lift-stool/">https://www.hausmann.com/product/heavy-duty-air-lift-stool/</a>	2151	2	NO BID	NO BID	Vinyl Color: Black (V23)	Logo: (NO-LOGO)							
FN-5A	Trainers Office (Rm# 459A)	L-Desk	HON	10500 Series	72"x36" Rectangle Shell, 2 grommets	H10594	1	\$390.90	\$390.90	Laminate: Pinnacle (PINC)	Edge Band: Pinnacle (PINC)							
FN-5B	Trainers Office (Rm# 459A)	L-Desk Return	HON	10500 Series	48"W x 24"D Return, 1 grommet	H10561	1	\$254.10	\$254.10	Laminate: Pinnacle (PINC)	Edge Band: Pinnacle (PINC)							
FN-6	Trainers Office (Rm# 459A)	BBF Pedestal	HON	10500 Series	15.75"W x 22.75"D x 28.24"H, Mobile	H105102	1	\$414.00	\$414.00	Laminate: Pinnacle (PINC)	Edge Band: Pinnacle (PINC)							
FN-7	Trainers Office (Rm# 459A)	FF Pedestal	HON	10500 Series	15.75"W x 22.75"D x 28.24"H, Mobile	H105104	1	\$414.00	\$414.00	Laminate: Pinnacle (PINC)	Edge Band: Pinnacle (PINC)							
	Trainers Office (Rm# 459A)	L-Desk	HON		Key Core	HF23S.X112	2	\$17.80	\$35.60									
FN-5A	Trainers Office (Rm# 459A)	Rectangle Desk	HON	10500 Series	72"x36" Rectangle Shell, 2 grommets	H10594	1	\$390.90	\$390.90	Laminate: Pinnacle (PINC)	Edge Band: Pinnacle (PINC)							

MARK	LOCATION	Product Type	Manufacturer	Series	Product	Model #	QTY	\$/Unit	Extended Price	Finish 1	Finish 2	Finish 3	Finish 4	Finish 5	Finish 6	Finish 7	Finish 8	NOTES
FN-6	Trainers Office (Rm# 459A)	BBF Pedestal	HON	10500 Series	15.75"W x 22.75"D x 28.24"H, Mobile	H105102	1	\$414.00	\$414.00	Laminate: Pinnacle (PINC)	Edge Band: Pinnacle (PINC)							
FN-7	Trainers Office (Rm# 459A)	FF Pedestal	HON	10500 Series	15.75"W x 22.75"D x 28.24"H, Mobile	H105104	1	\$414.00	\$414.00	Laminate: Pinnacle (PINC)	Edge Band: Pinnacle (PINC)							
	Trainers Office (Rm# 459A)	Rectangle Desk	HON		Key Core	HF23S.X113	2	\$17.80	\$35.60									
FN-1	Trainers Office (Rm# 459A)	Guest Chair	HON	Ignition	Multipurpose Chair	HIGS6	2	\$264.50	\$529.00	Mesh: Black	Seat Fabric: Grade 3 - Moxie - Tangerine							Same specs as the Admin
FN-24A	Trainers Office (Rm# 459A)	Wardrobe/Storage	HON	Brigade	36"W x 24"D x 72"H	HSC2472	3	\$666.90	\$2,000.70	Paint: Loft	Handle: Silver							
FN-24B	Trainers Office (Rm# 459A)	Conversion Bar	HON	Brigade	36"W	HWC72	1	\$59.20	\$59.20									
									<b>Furniture Subtotal:</b>	<b>\$57,285.60</b>								
									<b>Installation:</b>	<b>\$7,835.00</b>								
									<b>Total:</b>	<b>\$65,120.60</b>								
<b>NOTES:</b>																		
All Pricing per OMNIA Contract# 07-91																		
UNION Installation																		
Straight Time																		
No Stair Carry																		
All Trash Removed off site																		
<b>Accepted By:</b>																		
Signature _____																		
Printed Name _____																		
Dated _____																		



Joelle Sexton  
 226 S 5th St - Dekalb, IL 60115-3815  
 (815) 212-5736 - jlsexton@herffjones.com

# PRINTING AGREEMENT

Year(s) Covered:  2025  2026  2027  2028  2029  
 New  Renewal

Date: 2/26/2024

Three-year agreement includes an additional 15 extra books at no cost valued at \$545. Ongoing service and training with 5 Star also included valued at \$1000!

Subject to the terms hereof, the Customer (school) named below hereby engages Hercules Achievement, LLC. d/b/a Varsity Yearbook ("Company"), and Company agrees, to print and bind the specified publication during the Years Covered (specified above).

**School Name: Minooka High School**

Address: 301 South Wabena  
 City/State/Zip: Minooka, IL 60447  
 Job Number: 8202  
 Title/Publication:  
 Current Enrollment: 2525

**Specifications**

Program: 900 All Color  
 Trim Size: 9 X 12  
 Pages: 252  
 Copies: 1200  
 Submission Method: Web (eDesign)  
 Cover: Litho  
 Multi Year Award Free Copies

**Correspond With**

Name : Mr. Ron Maruszak  
 Title:  
 Address: 301 S Wabena Ave  
 City/State/Zip: Minooka, IL 60447-9466  
 Phone Number:  
 Fax Number:  
 Email: rmaruszak@mchs.net

Binding: Squarebacked  
 Endsheets: Vibracolor  
 Digital E/S Proof in Wrike

Paper: 80# Gloss

Proofs: eProofs on CD (with 4-C hard copies)  
 Self Proof (eDesign)

**Send Invoice To**

Name : Mr. Ron Maruszak  
 Title:  
 Address: 301 S Wabena Ave  
 City/State/Zip: Minooka, IL 60447-9466  
 Phone Number:  
 Tax Exemption Number: E9996-7571-07  
 Pre-Payment Option Desired:  Yes  No

**Base Price: \$44,803.66**

**Additional Features**

Camp Scholarship	\$0.00
Color Plus	\$0.00
Early Renewal Discount by 6/1 -\$600	\$0.00
eBusiness Merchandising Software	\$0.00
Regular Service Visits	\$0.00
Sales and Marketing Materials	\$0.00
Unlimited Technical Support	\$0.00
Unlimited Use of HJ Software	\$0.00
Yearbook Curriculum Materials	\$0.00

**Printing Agreement Total: \$44,803.66**

**Shipping Information**

Requested Book Ship Date: May 10, 2025  
 Ship Book To : Mr. Ron Maruszak  
 Requested Kit Ship Date:  
 Ship Kit To : Mr. Ron Maruszak

Thank you for choosing Herff Jones as your yearbook printer. Your customer loyalty is greatly appreciated! Specifications can be changed to meet customers' needs.

This agreement is subject to the terms shown on the reverse side and is binding on Company and the Customer for the Years Covered, subject to such terms.

Ron Maruszak

YEARBOOK PLANT USE \_\_\_\_\_  
 Customer Number \_\_\_\_\_ Date Received \_\_\_\_\_

John Troy  
 363   
 Joelle Sexton Company Representative

## Terms and Conditions of This Yearbook Printing Agreement

This **Yearbook Printing Agreement** will be governed by Texas law. The "Years Covered" by this **Yearbook Printing Agreement** are shown at the top of the facing page. The Base Specifications on the facing page apply to the publication for the first Year Covered and shall likewise apply to each Book(s) for each subsequent Year Covered, as applicable, unless modified specifications for subsequent years are agreed in writing ("Modified Base Specifications"). Modified Base Specifications shall be conclusively authorized by **Customer** when signed only by an Authorized School Representative named on the facing page (or his or her successor). Base Specifications (or any Modified Base Specifications) shall only become final and binding upon **Hercules Achievement, LLC. d/b/a Varsity Yearbook ("Company")** upon written acceptance by the **Company** printing facility of such specifications (including price). **Company** printing facility will determine shipment date upon confirmation of specifications for a Year Covered. For each Year Covered after the first year, the deadline for submission of Modified Specifications is October 1 of the prior school year. If **Customer** has not provided signed Modified Specifications by such date, the Base Specifications on the facing page shall apply to such Year Covered and **Company** shall print the Book(s) for such year on such basis. **Customer** agrees to prepare all copy in strict accordance with instructions and materials furnished by **Company**.

If this **Yearbook Printing Agreement** covers more than one (1) year, then, **Company** shall provide to **Customer** fifteen (15) additional copies of each year's Book free of charge for the term of the **Yearbook Printing Agreement**. If this **Yearbook Printing Agreement** covers more than one (1) year, the **Customer** acknowledges that **Company** is relying upon the **Customer's** commitment herein for the following: To purchase supplies of paper, ink, and cover manufacturing materials; To determine staffing levels based upon expected production demands and timelines, given known capacities; To make financial investments in its programs, processes and technology improvements.

**Company** will not be liable for losses or delays as a result of strikes, accidents, acts of God, government restrictions, or any other cause beyond its control and such delays shall not constitute a breach of contract.

**Ship Date** will be maintained as specified herein, provided that the Submission Deadlines approved and/or published by **Company** have been met as specified. **Ship Date** for subsequent years covered will remain in same week, adjusted for calendar date shift. All Shipments are F.O.B. the printing facility, including extra copies should they be available.

For each year covered, **Customer** agrees to pay a first deposit equal to 40% of the total contract price at the time of the first copy deadline, and a second deposit equal to 50% of the total contract price at the time of the final copy deadline, bringing the total deposits to 90% of the contract price. All final invoices will be issued upon shipment of the books and are due upon receipt of the invoice. A service charge of 1.5% per month (18% annual percentage rate) will be applied on all unpaid balances after 90 days.

**Customer** represents and warrants that it has all necessary rights to any materials provided to **Company** for inclusion in **Customer's** Book(s). **Customer** will not provide any materials to **Company** which are or may be in violation of any right or any third party, including copyright. **Company** does not knowingly intend to print any material which is in violation of any copyright or proprietary rights, or is tortuous or illegal. **Company** reserves the right to refuse to print or otherwise prepare for publication any material which, in its sole discretion, could result in legal liability, and such refusal shall not constitute a breach of contract. To the extent permitted by the laws of the state in which **Customer** is located (as identified herein), **Customer** agrees to indemnify, defend, and hold harmless **Company** and its agents or employees in connection with claims, suits, damages, losses, liabilities, costs and expenses, including attorney's fees resulting from or arising out of printing of any material submitted to **Company** by **Customer** or its representative.

**Customer** acknowledges and agrees that **Company** may use reproduction, samples or copies of **Customer's** Book(s) for educational, recognition, marketing or other promotional purposes without compensation to **Customer**. Any future sales of the Book(s) or other uses of the Book(s) may be made by **Company** in its sole discretion and without any compensation to **Customer**.

If **Customer** elects to use **Company's** proprietary computer software (eDesign) to submit copy for the Book(s) to **Company** (the "eDesign System"), then **Customer** agrees as follows:

- a) **Company** will provide **Customer** the eDesign System User Subscription Agreement and Privacy Agreement (the "eDesign Agreements");
- b) **Customer's** acceptance of the eDesign Agreements creates a binding contract;
- c) any violation of the terms of the eDesign Agreements by **Customer** will constitute a default by **Customer** of the terms of this **Yearbook Printing Agreement**.

This **Yearbook Printing Agreement** and any amendments may be executed in one or more counterparts, all of which constitute one and the same instrument. Any such counterpart signature may be delivered by means of an application on a mobile device, attachment to electronic mail or other lawful electronic means and shall be treated in all respects as an original executed counterpart and shall have the same binding legal effect as if it were the original signed and delivered in person.

Initial below:

\_\_\_\_\_  
Company Representative



Joelle Sexton  
226 S 5th St - Dekalb, IL 60115-3815  
(815) 212-5736 - jlsexton@herffjones.com

# PRINTING AGREEMENT

Year(s) Covered:  2025  2026  2027  2028  2029

Date: 2/26/2024

Subject to the terms hereof, the Customer (school) named below hereby engages Hercules Achievement, LLC. d/b/a Varsity Yearbook ("Company"), and Company agrees, to print and bind the specified publication during the Years Covered (specified above).

### School Name: Minooka HS Supplement

Address: 301 South Wabena  
City/State/Zip: Minooka, IL 60447  
Job Number: 8202

### Specifications

Program: 900 Quick Turn Supplement  
Trim Size: 9 X 12  
Pages: 36  
Copies: 1200  
Submission Method: Web (eDesign)  
Cover: Self Cover w/Kleenstick

### Correspond With

Name : Mr. Ron Maruszak  
Title:  
Address: 301 S Wabena Ave  
City/State/Zip: Minooka, IL 60447-9466  
Phone Number:  
Fax Number:  
Email: rmaruszak@mchs.net

Binding: Saddle Stitched Binding

Endsheet:

Paper: 80# Gloss Paper

Proofs: Proofing method for eDesign schools

**Base Price: \$5,295.00**

### Send Invoice To

Name : Mr. Ron Maruszak  
Title:  
Address: 301 S Wabena Ave  
City/State/Zip: Minooka, IL 60447-9466  
Phone Number:  
Tax Exemption Number: E9996-7571-07

### Additional Features

2 Wks without image enhancement Included

**Printing Agreement Total: \$5,295.00**

### Shipping Information

Requested Supplement Ship Date: August 02, 2025  
Ship Book To : Mr. Ron Maruszak

This agreement is subject to the terms shown on the reverse side and is binding on Company and the Customer for the Years Covered, subject to such terms.

\_\_\_\_\_  
Ron Maruszak

YEARBOOK PLANT USE

Customer Number \_\_\_\_\_ Date Received \_\_\_\_\_

John Troy Assistant Superintendent of Business and General Counsel  
365

Joelle Sexton

Company Representative

**Terms and Conditions of This Yearbook Printing Agreement**

This **Yearbook Printing Agreement** will be governed by Texas law. The "Years Covered" by this **Yearbook Printing Agreement** are shown at the top of the facing page. The Base Specifications on the facing page apply to the publication for the first Year Covered and shall likewise apply to each Book(s) for each subsequent Year Covered, as applicable, unless modified specifications for subsequent years are agreed in writing ("Modified Base Specifications"). Modified Base Specifications shall be conclusively authorized by **Customer** when signed only by an Authorized School Representative named on the facing page (or his or her successor). Base Specifications (or any Modified Base Specifications) shall only become final and binding upon **Hercules Achievement, LLC. d/b/a Varsity Yearbook ("Company")** upon written acceptance by the **Company** printing facility of such specifications (including price). **Company** printing facility will determine shipment date upon confirmation of specifications for a Year Covered. For each Year Covered after the first year, the deadline for submission of Modified Specifications is October 1 of the prior school year. If **Customer** has not provided signed Modified Specifications by such date, the Base Specifications on the facing page shall apply to such Year Covered and **Company** shall print the Book(s) for such year on such basis. **Customer** agrees to prepare all copy in strict accordance with instructions and materials furnished by **Company**.

If this **Yearbook Printing Agreement** covers more than one (1) year, then, **Company** shall provide to **Customer** fifteen (15) additional copies of each year's Book free of charge for the term of the **Yearbook Printing Agreement**. If this **Yearbook Printing Agreement** covers more than one (1) year, the **Customer** acknowledges that **Company** is relying upon the **Customer's** commitment herein for the following: To purchase supplies of paper, ink, and cover manufacturing materials; To determine staffing levels based upon expected production demands and timelines, given known capacities; To make financial investments in its programs, processes and technology improvements.

**Company** will not be liable for losses or delays as a result of strikes, accidents, acts of God, government restrictions, or any other cause beyond its control and such delays shall not constitute a breach of contract.

**Ship Date** will be maintained as specified herein, provided that the Submission Deadlines approved and/or published by **Company** have been met as specified. **Ship Date** for subsequent years covered will remain in same week, adjusted for calendar date shift. All Shipments are F.O.B. the printing facility, including extra copies should they be available.

For each year covered, **Customer** agrees to pay a first deposit equal to 40% of the total contract price at the time of the first copy deadline, and a second deposit equal to 50% of the total contract price at the time of the final copy deadline, bringing the total deposits to 90% of the contract price. All final invoices will be issued upon shipment of the books and are due upon receipt of the invoice. A service charge of 1.5% per month (18% annual percentage rate) will be applied on all unpaid balances after 90 days.

**Customer** represents and warrants that it has all necessary rights to any materials provided to **Company** for inclusion in **Customer's** Book(s). **Customer** will not provide any materials to **Company** which are or may be in violation of any right or any third party, including copyright. **Company** does not knowingly intend to print any material which is in violation of any copyright or proprietary rights, or is tortuous or illegal. **Company** reserves the right to refuse to print or otherwise prepare for publication any material which, in its sole discretion, could result in legal liability, and such refusal shall not constitute a breach of contract. To the extent permitted by the laws of the state in which **Customer** is located (as identified herein), **Customer** agrees to indemnify, defend, and hold harmless **Company** and its agents or employees in connection with claims, suits, damages, losses, liabilities, costs and expenses, including attorney's fees resulting from or arising out of printing of any material submitted to **Company** by **Customer** or its representative.

**Customer** acknowledges and agrees that **Company** may use reproduction, samples or copies of **Customer's** Book(s) for educational, recognition, marketing or other promotional purposes without compensation to **Customer**. Any future sales of the Book(s) or other uses of the Book(s) may be made by **Company** in its sole discretion and without any compensation to **Customer**.

If **Customer** elects to use **Company's** proprietary computer software (eDesign) to submit copy for the Book(s) to **Company** (the "eDesign System"), then **Customer** agrees as follows:

- a) **Company** will provide **Customer** the eDesign System User Subscription Agreement and Privacy Agreement (the "eDesign Agreements");
- b) **Customer's** acceptance of the eDesign Agreements creates a binding contract;
- c) any violation of the terms of the eDesign Agreements by **Customer** will constitute a default by **Customer** of the terms of this **Yearbook Printing Agreement**.

This **Yearbook Printing Agreement** and any amendments may be executed in one or more counterparts, all of which constitute one and the same instrument. Any such counterpart signature may be delivered by means of an application on a mobile device, attachment to electronic mail or other lawful electronic means and shall be treated in all respects as an original executed counterpart and shall have the same binding legal effect as if it were the original signed and delivered in person.

Initial below:

  
\_\_\_\_\_  
Company Representative

  
\_\_\_\_\_  
Assistant Superintendent of Business and General Counsel

Assistant Superintendent of Business and General Counsel

# Minooka Community High School Handbook Revisions

2024/2025

## Proposed Procedures/Language

### 1. Excessive Absences - Page 24

## Proposed New Language & Changes

### **ATTENDANCE POLICY**

Regular school attendance is essential for academic success, and is required in all classes held at MCHS attendance centers, including JJC and GAVC courses. The state of Illinois compulsory attendance laws are very specific concerning the matters of student attendance in public schools.

### **EXCUSED ABSENCES**

Based on Section (26-2A) of the Illinois School Code VALID CAUSES for an excused absence include the following:

- a. Personal illness or physical disability. This includes hospitalization, outpatient treatment, mandatory doctor consultation, and emergency appointments (each request will be dealt with individually) if verified by a student's doctor/dentist. Students must present a card/note from the doctor/dentist to verify the appointment.
- b. Critical illness or death in the immediate family. This includes funerals and necessary travel.
- c. Mental and behavioral health of the student (maximum of 5 days per school year).
- d. Approved school activities. This includes all field trips, both co and extracurricular events scheduled during school hours, college visitations with proper documentation and other sanctioned events.
- e. Absences from class period due to conferences with Minooka Community High School administrators, counselors, nurses, or other staff members.
- f. Court appearances. Students must present a statement from the court showing appearances.
- g. Others as determined by MCHS Deans and/or Administration.

### **EXCESSIVE ABSENCES**

Excessive absences can interfere with student achievement. As defined by Illinois School Code(26-2a), a student who has been absent without valid cause for 5% or more of the previous 180 regular attendance days is considered to be truant.

### **STUDENT ATTENDANCE INTERVENTIONS**

When a student reaches each of the following accumulated days of absence from school, a letter will be sent home and the following interventions will take place:

1. **4 Days:** Attendance Letter Notification from Deans' Office regarding attendance requirements.

2. **8 Days:** Attendance Letter Notification from Deans' Office regarding attendance requirements. Medical documentation may be required after 8 absences. Attendance meetings may be required to discuss attendance expectations.
  3. **14 Days:** Parent/Student meeting with Student Support Team to discuss attendance concerns, formulate attendance plan, and discuss future implications for continued excessive absences. Social Suspension may be issued if continued excessive absences accumulate.
  4. **18 Days:** Truancy referral to Grundy County Regional Office of Education. Truancy Caseworker for the following reasons:  
*Chronic absenteeism* (Sec. 26-18) means absences that total 10% or more of school days of the most recent academic school year, including absences *with and without valid cause*.  
*Chronic or habitual truant* (Sec. 26-2a) shall be defined as a child who is subject to compulsory school attendance and who is absent without valid cause from such attendance for 5% or more of the previous 180 regular attendance days.
- All of the following current attendance policies will remain the same for the 2024-2025 school year:
    1. Excused Absences
    2. Reporting an Absence
    3. Tardy
    4. Truancy
    5. Unexcused Absences

## Current Language - Remove

### **EXCESSIVE ABSENCES**

~~A student may accumulate seven (7) absences within each semester. Any absence following the seventh absence will be unexcused. In order for the absence to be excused, a student will be required to provide documentation from the list below. This policy will apply to a student being absent from a single class period seven times and/or a student missing two or more class periods, which will count as a full day absence, for seven days. Seven (7) absences does not equal seven (7) days. Absence from one class is equal to a ½ day absence per the ISBE attendance policy. Note that vacation days will be included as part of the 7 total days allowed per semester. Be advised extended vacation beyond seven days will turn into unexcused absences, which will prevent credit for make up work. A Vacation Form (available in the Deans' Office) must be submitted. Arrangements for absences due to doctor appointments, court appearances, vacations, etc., should be made in advance. It is recommended to bring in documentation for any absence listed below every time an absence of this type occurs in order to avoid an accumulation of unexcused absences due to lack of documentation. Provided documentation, from the list below, will not count towards a student's seven (7) absences allowed per semester. Documentation must be provided within 48 hours.~~

- ~~1. Doctor/Dentist Note~~
- ~~2. Death in the family~~
- ~~3. Court appearance~~
- ~~4. College visit~~
- ~~5. Hospitalization~~

~~Example of absences that **will** count towards a student's seven (7) absences allowed per semester:~~

- ~~1. Sick without Doctor note~~
- ~~2. Vacation~~
- ~~3. Tardy/late to school greater than 30 minutes~~
- ~~4. Student sent home through the nurse's office~~
- ~~5. Unexcused absence~~

~~Again, an UNEXCUSED ABSENCE even with a parent phone call prevents the student from earning academic credit for that absence, and the student may receive disciplinary consequences:~~

## Proposal: PC6497

DePue Mechanical, Inc.  
PO Box 857  
Minooka, IL 60447



Revision: 0

# Minooka Community High School South Campus - Cooling Tower Replacement



**MINOOKA**  
COMMUNITY HIGH SCHOOL

### Customer:

Minooka Community High School South Campus  
26655 W. Eames St  
Channahon, IL 60410

**Valid Until: 4/30/2024**

# Proposal: PC6497

DePue Mechanical, Inc.  
PO Box 857  
Minooka, IL 60447



---

## Investment Summary

We herewith submit our proposal to furnish all necessary labor, supervision, materials, tools, equipment, and consumables to complete the scope of work as described below and in the Invitation to bid sent via email on April 2, 2024, Addendum 1 sent via email on April 8, 2024 and the Jobsite Walk on February 9, 2024

The below mentioned scope of work can be completed for the firm, Lump Sum Investment of:

**Three Hundred Eighty Two Thousand Seven Hundred Sixty Eight Dollars and Zero Cents:**

**(\$382,768.00)**

---

## Scope of Work

### Mechanical:

- Disconnect of existing cooling tower piping
- Demo and removal of existing cooling tower
- Furnish and install of One (1) new 2 cell cooling tower (Please see attached Cooling Tower Specs for reference)
- Installation of shipped loose items for cooling tower (i.e. handrail, fan guards, etc.)
- Fabrication and installation of approximately 100 ft of 8" CS Sch. 40 pipe with grooved ends
- Fabricate and install approximately 60 ft of 6" CS Sch. 40 pipe with grooved ends
- Fabricate and install approximately 20 ft of 10" CS Sch. 40 pipe with grooved ends
- Furnish and install all required new vic clamps with gaskets (water service)
- Furnish and install 10" equalization line including drain valve
- Furnish and install water make up line using pro-press copper
- Furnish and install overflow drain using PVC schedule 40

### Electrical:

- Demolition of conduits & wiring supported to existing tower
- Cooling tower motor disconnects
- Pull wire & cable back to junction boxes located inside building
- Two (2) new NEMA 3R 60amp disconnects
- Two (2) motor disconnects
- Six (6) instrument connections
- All new rigid conduit, fittings & wire

# Proposal: PC6497

DePue Mechanical, Inc.  
PO Box 857  
Minooka, IL 60447



- All terminations, testing & labels
- Background Checks
- Commissioning assistance (8 hours)

## Painting:

- All Carbon Steel pipe to be wired brushed and solvent wiped clean
- Roller apply one (1) coat of PPG's Amerlock 2 epoxy and two coats of PPG's durethane
- All painting to be completed in the field after installation of piping

## Exclusions, Assumptions, Clarifications

### General

1. Pipe System - Cleaning or Flushing is not included
2. Disassembly or Reassembly of any equipment furnished by Owner/Others – unless specifically identified in DePue Scope-of-Work.
3. Furnishing of glycol, freon, or refrigerant is excluded
4. Site Temporary Dumpsters, Port-o-Lets, Power (Power to be made available to DePue at no charge), and Office or Lunch Space to be provided by owner/other
5. No relocation of existing piping or systems to accommodate work – unless specifically identified in DePue Scope-of-Work.
6. Furnishing of Temporary Heating or Cooling is not included
7. Roof Penetrations are not included
8. Motor Starters, Disconnects, VFD are excluded (N.I.S.) unless specifically indicated otherwise in the scope-of-work section of DePue Proposal.
9. Winter and Weather Protection – excluded (N.I.S)
10. Furnishing or Installation of Roof Curbs is not included - DePue to set new towers on existing roof steel supports
11. Piping System – Identification, Labels and/or Valve Markers & Tags/ID are not included
12. ADDER OPTION: The SPX Cooling Tech, LLC Certification of Limited Warranty ("Warranty Certificate") shall include a 5 year labor warranty. All other terms of the Warranty Certificate remain unchanged and in effect. Please ADD \$13,490.00 if required
13. Additional service calls after start-up, including diagnostic issues - billed hourly as needed
14. DePue Mechanical Requires a 15% down payment at time of Purchase Order
15. Current Product Lead time of Cooling Tower (from date of written release to shipment from factory) is approximately 25 weeks
16. Please note there will be a material price increase of the cooling tower of 4% if not released by March 22, 2024
17. ADDER OPTION: Furnish (2) VFD 20 HP 3/50/60 480 NEMA 1 indoor painted steel enclosure ABB ACH580 w/ options NFD + E-Clipse bypass. Demo of existing and re hook up of new. If new VFD's are required Please ADD \$11,950.00 if required
18. Please see attached EXHIBIT B for existing cooling tower catalog

### Subcontractors

1. Furnishing of scaffolding of any kind is excluded (N.I.S.) unless specifically indicated otherwise in the scope-of-work section of DePue Proposal.
2. No Fire Protection work of any kind has been included in Proposal
3. No Structural Steel work of any kind has been Included in Proposal
4. No Roofing work of any kind has been Included in Proposal
5. Fire alarms, exterior lighting, Instruments, Instrument calibrating or bench testing, BAS Terminations are not included in proposal

# Proposal: PC6497

DePue Mechanical, Inc.  
PO Box 857  
Minooka, IL 60447



6. Insulation of make up water only has been included

## Labor

1. Start-up Assistance and/or Standby Assistance except as specifically included under Scope-of-Work (the services can be furnished on a Time and Material basis at additional cost to the contract.)
2. Premium, Overtime and/or Shift Work to Meet Schedule - excluded (N.I.S.)

## Finanical

1. Performance Bond has been included in proposal pricing
2. State Sales and Use Tax. If work is to be tax exempt - Owner to furnish appropriate documentation to support, evidence that project/Owner facility is "Tax Exempt."
3. Permit Fees & Permitting Assistance by Owner/Others
4. Bid Bond EXHIBIT C attached

## Materials

1. Due to the current Volatility of the Market, All Material Pricing will need to be Re-quoted once Depue Mechanical has been Awarded the Project Additional Cost may be Added to the Project.

## QA/QC

1. NDE (Radiography, dye penetrant, ultrasonic, etc.) is not included in this proposal. All piping to be in service tested

## Engineering

1. Floor or Wall Scanning, X-raying of any type is not Included in Proposal
2. Seismic Bracing of any kind - work or calculations are not included
3. Furnish of Coordination Drawings is not Included in Proposal
4. Furnishing of CAD As-Built Drawings (other than manual marked-up 'red-line')
5. Engineering and Professional Design Services are excluded (N.I.S.) unless specifically indicated otherwise.
6. Stamped drawings by Licensed Professional Engineers

## Safety

1. LOTO, isolation and making lines safe for tie-ins to be performed by Owner with coordination by Depue Mechanical
2. Roof and/or Building Fall Protection and Access Engineering Controls and/or Other Controls are - excluded (N.I.S) and to be furnished Owner/Others as required.

## Thank you !!

Mr. Troy, Thank you for the opportunity to provide you with a proposal for this work! Please, anything you need, just let us know. We take a lot of pride in our long-term relationships with client-friends just like you and not only constructing projects but engaging as a resource in the project budgeting and design-development stages as well to ensure maximum project success.

DePue Mechanical is very eager to start this project with you !

If there are any questions in regard to our proposal, please let me know! You can call me anytime on my cell phone (815) 514-0103.

# Proposal: PC6497

DePue Mechanical, Inc.  
PO Box 857  
Minooka, IL 60447



Thank you Mr. Troy!

Very Respectfully,

**Niko Capodice**

niko.capodice@depuemechanical.com

(815) 514-0103 (cell)

(815) 255-2500 (office)

26655 W. Eames Street  
Channahon, IL 60410

# Assurances and Certifications

## PART 1

### STATEMENT OF ETHICS CERTIFICATION

By submission of this bid or proposal, the bidder certifies that:

1. This bid or proposal has been independently arrived at without collusion with any other bidder or with any competitor.
2. This bid or proposal has not been knowingly disclosed and will not be knowingly disclosed, prior to the opening of bids or proposals for this project, to any other bidder, competitor or potential competitor.
3. No attempt has been made or will be made to induce any other person, partnership or corporation to submit or not to submit a bid or proposal.
4. Bidder has not been convicted of price fixing nor pleaded "no contest" to such charges within the last five (5) years.
5. Bidder is not subsidiary of a company that has been convicted of price fixing nor pleaded "no contest" to such charges within the last five (5) years.

By:   
Authorized Agent

SUBSCRIBED and SWORN TO before me

this 11 day of April, 2024

  
NOTARY PUBLIC

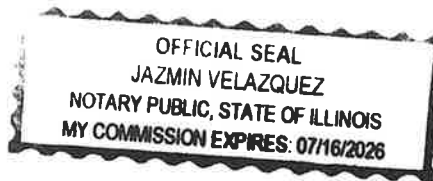

This page must be returned signed and notarized for the bid to be considered.

**Minooka Community High School District 111**

26655 W. Eames Street  
Channahon, IL 60410

## Assurances and Certifications PART 2

### SUPPLIER'S/CONTRACTOR'S CERTIFICATION

As part of its bid, the supplier/contractor does hereby certify that said supplier/contractor is not barred from bidding on the contract as a result of violation of either Section 33E-3 or 33E-4 of Article 33E of Chapter 38 of the Illinois Revised Statutes.

By:   
Authorized Agent

### CERTIFICATE OF COMPLIANCE WITH ILLINOIS DRUG-FREE WORKPLACE ACT (Suppliers/Contractors with 25 or More Employees)

As part of its bid, the supplier/contractor does hereby certify pursuant to section 3 of the *Illinois Drug-Free Workplace Act* (Ill.Rev.Stat. ch 127. para. 132.313) that [he, she, it] shall provide a drug-free workplace for all employees engaged in the performance or work under the contract by complying with the requirements of the *Illinois Drug-Free Workplace Act* and, further certifies, that [he, she, it] is not ineligible for award of this contract by reason of debarment for a violation of the *Illinois Drug-Free Workplace Act*.

By:   
Authorized Agent

Does Not Apply (Less than 25 Employees)

By: \_\_\_\_\_  
Authorized Agent

SUBSCRIBED and SWORN TO before me

this 11 day of April, 2024

  
NOTARY PUBLIC

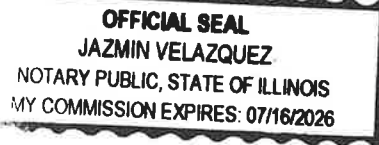

This page must be returned signed and notarized for the bid to be considered.

Minooka Community High School District 111  
26655 W. Eames Street  
Channahon, IL 60410

## Assurances and Certifications PART 3

### CERTIFICATE OF COMPLIANCE WITH ILLINOIS HUMAN RIGHTS ACT

#### Sexual Harassment Policies

As part of its bid, the supplier/contractor does hereby certify pursuant to 775 ILCS 5/2-105 that [he, she, it] has written sexual harassment policies that include at least the minimum information as required by law; that a copy of the policies shall be provided to the Department of Human Rights upon request; and that [he, she, it] is not ineligible for award of this contract by reason of debarment for a violation of the *Illinois Human Rights Act*.

By:   
Authorized Agent

#### Equal Employment Opportunity

As part of its bid, the supplier/contractor does hereby certify pursuant to 775 ILCS 5/2-104 that [he, she, it] complies with the procedures and requirement of the Illinois Department of Human Rights regulations concerning equal employment opportunities and affirmative action, shall provide such information with respect to its employees and applicants for employment and assistance as the Department may reasonably request, and that [he, she, it] is not ineligible for award of this contract by reason of debarment for a violation of the *Illinois Human Rights Act*.

By:   
Authorized Agent

SUBSCRIBED and SWORN TO before me

this 11 day of April, 2021

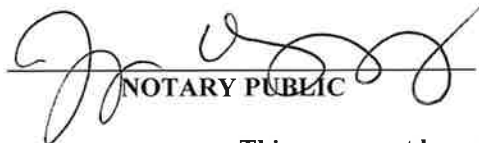
  
NOTARY PUBLIC



This page must be returned signed and notarized for the bid to be considered.

Minooka Community High School District 111  
26655 W. Eames Street  
Channahon, IL 60410

# Assurances and Certifications PART 4

AGREEMENT TO BE BOUND BY THE TERMS OF THE BID

If the contract is awarded to the contractor, the contractor hereby adopts, accepts, and agrees to be bound by all the terms and conditions of the MINOOKA COMMUNITY HIGH SCHOOL DISTRICT 111 WATER COOLING TOWER REPLACEMENT bid.

By:   
Authorized Agent

Equal Employment Opportunity

SUBSCRIBED and SWORN TO before me

this 11 day of April, 2024

  
NOTARY PUBLIC



This page must be returned signed and notarized for the bid to be considered.

# EXHIBIT A





**WINDY CITY REPRESENTATIVES  
ENGINEERED SYSTEMS**

**Subject: Minooka HS CT Replacement  
Existing S/N 818648  
SD 111 RFP for Cooling Tower Replacement**

**Terms:** F.O.B. Factory, Freight Allowed and Prepaid, Progress Payments: 30% at Time of Order and 70% at Time of Shipment, Net 30 Day Terms, Taxes NOT Included, Quote Valid for 30 Days

**ITEM I  
COOLING TOWER**

TOWER MODEL	PERFORMANCE CONDITIONS	MOTOR DATA	TOWER DIMENSIONS	WEIGHTS
Quantity of (1) Marley NC Class model <b>NC8405QAN</b> factory assembled 2-Cell crossflow cooling tower	Per 2-cell tower: 2,400 gpm 95.0 °F Hot Water 85.0 °F Cold Water 78.0 °F Entering WB	NEMA 20 HP 1 speed / 1 wind 3 phase / 60 Hz / <b>230/460v</b> 1.15sf / TEFC 1800 RPM Premium Efficiency Inverter duty nameplated <i>Site Voltage: 480</i>	Each cell: (without options) Length 9' - 10 3/4" Width 19' - 11" Height 11' - 11 3/4" Per 2-cell tower: (with options) Length 20' - 9 15/16" Width 19' - 11" Height 15' - 0 7/8"	Per cell: Shipping: 9,352 lb Operating: 20,148 lb Per 2-cell tower: Shipping: 18,704 lb Operating: 40,296 lb

*Quantities shown below are per tower.*

**Base Tower Construction/Equipment:**

- Stainless Steel casing.
- Stainless Steel structure.
- Stainless Steel (per SS Grade) collection basin.
- Stainless Steel (per SS Grade) distribution basin.
- All stainless steel is series 300.
- Custom anchorage design to fit customer's grillage at 220.50 in spacing.
- Low Sound fan with aluminum blades.
- Marley designed Geareducer® with 5-year warranty.
- PVC film fill with integral louvers and drift eliminators designed and manufactured by Marley.
- Published sound data is independently verified by a CTI licensed test agency.
- CTI certification per STD-201.
- 12 in fan cylinder extension.
- HDG steel fan guard.

**Collection Basin Connections and Accessories:**

- All flanges are to Class 125 ANSI B16.1 standard.
- All threads are to American Standard Pipe Taper Thread.
- (2) 8 in (203 mm) diameter bevel and groove cased face outlet(s) with trash screen(s).
- 10 in (254 mm) diameter hole and bolt circle(s) for equalization, One per Cell
- 4 in (102 mm) diameter combination drain and overflow in each cell
- (2) 1 in (25.4 mm) water make-up float valve(s)
- Probe type electronic water level sensor, in cells with outlets, with the following events: make-up, low-alarm, high-alarm

**Distribution Basin Inlet and Accessories:**

- (2) 6 in (152 mm) diameter top inlet connections per cell.
- (2) 6 in (152 mm) horizontal flow control valves per cell.
- Variable flow nozzles.

**Maintenance & Maintenance Access Features:**

- Tower is designed in accordance with OSHA safety standards.

This quotation does not include features which are available to allow safe access on the fan deck while the fan is still operating. If this is a desired feature for your intended operation, please contact your sales representative.

Convenient access to the collection basin and plenum area is provided via a large access door located on each endwall

Easy fitting perimeter guardrail, kneerail & toeboard

(1) Cased face ladder

Ladders extended 60 in below base of tower

Easy fitting ladder safety cage(s)

**Control Systems:**

(1) IMI 685A Mechanical sw, DPDT, manual reset + 30' cord vibration cutoff switch per cell

**Warranty:**

5 year parts-only warranty included standard with SS constructed tower

**Freight:**

Included

ITEMS NOT INCLUDED

- Installation, owner training or commissioning/supervision
- Labor warranty or extended warranties not mentioned above
- Additional service calls after start-up, including diagnostic issues - billed hourly as needed
- Items not mentioned above

Current product lead time (from date of written release to shipment from factory):

23-24 weeks

# EXHIBIT B

# TOWER SCHEMATIC

NC8301 NC8302 NC8303 NC8304 **NC8305** NC8306

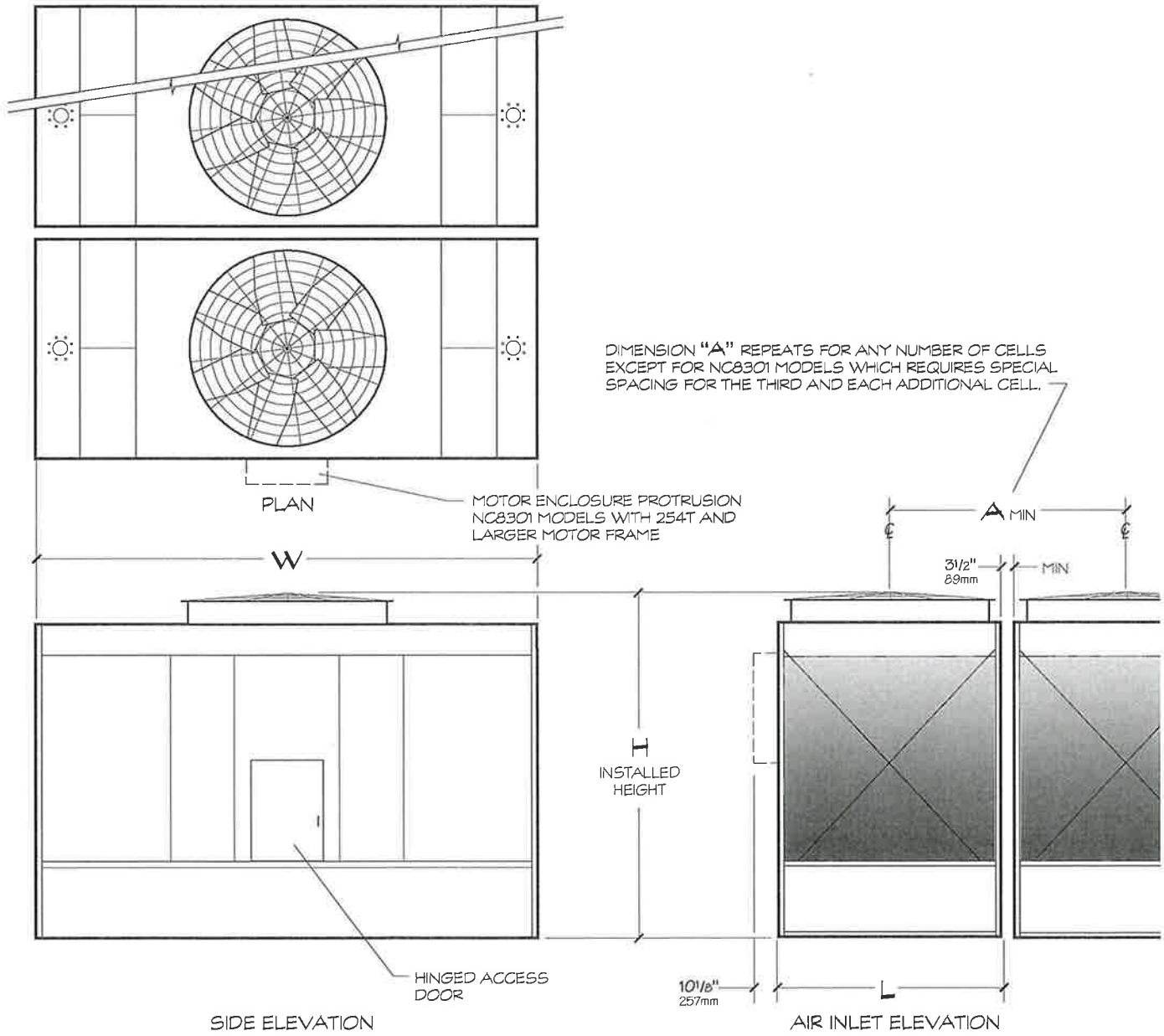

Tower Model Note 2	Nominal Tons Note 3	Motor hp	dBA 5'-0" from air inlet face	Design Operating Wt/Cell lb	Shipping Weight lb	DIMENSIONS			
						W	L	H	A
NC8301C-1	131	5	76	8654	4066	14'-0" 4268mm	6'-4 3/4" 1950mm	10'-1 5/8" 3090mm	6'-8 1/4" 2039mm
NC8301DL-1	150	7 1/2	75	8792	4204				
NC8301EL-1	167	10	78	8798	4210				
NC8302D-1	184	7 1/2	74	11075	4818	15'-6" 4725mm	7'-10 3/4" 2407mm	10'-2 3/8" 3109mm	8'-2 1/4" 2496mm
NC8302E-1	204	10	76	11101	4844				
NC8302FL-1	229	15	76	11256	4999				
NC8303DL-1	204	7 1/2	72	11656	5399	15'-6" 4725mm	7'-10 3/4" 2407mm	11'-11 1/4" 3639mm	8'-2 1/4" 2496mm
NC8303E-1	229	10	76	11501	5244				
NC8303FL-1	259	15	76	11656	5399				
NC8303G-1	284	20	80	11717	5460	17'-0" 5182mm	8'-10 3/4" 2712mm	12'-11 3/4" 3956mm	9'-2 1/4" 2801mm
NC8303H-1	297	25	81	12022	5765				
NC8304CL-1	247	7 1/2	66	14003	6328				
NC8304D-1	270	10	72	13817	6142				
NC8304E-1	310	15	76	13983	6308				
NC8304EL-1	311	15	72	14092	6417				
NC8304F-1	339	20	77	14044	6369				
NC8304FL-1	339	20	73	14154	6479				
NC8304G-1	362	25	82	14072	6397				
NC8304GL-1	363	25	76	14303	6628				
NC8304H-1	370	30	83	14463	6788	18'-9" 5715mm	10'-10 3/4" 3321mm	12'-11 3/4" 3956mm	11'-2 1/4" 3410mm
NC8305CL-1	281	7 1/2	66	18563	8268				
NC8305D-1	316	10	72	18414	8119				
NC8305E-1	363	15	76	18543	8248				
NC8305F-1	403	20	77	18604	8309				
NC8305FL-1	393	20	73	18744	8449				
NC8305G-1	431	25	82	18662	8367				
NC8305GL-1	431	25	76	18892	8597				
NC8305H-1	453	30	83	18724	8429				
NC8305HL-1	450	30	77	18958	8663				
NC8305J-1	501	40	86	18872	8577	19'-10" 6046mm	11'-10 3/4" 3626mm	12'-11 3/4" 3956mm	12'-2 1/4" 3715mm
NC8306EL-1	405	15	71	22221	10408				
NC8306F-1	441	20	74	21725	9912				
NC8306G-1	474	25	77	21827	10014				
NC8306H-1	503	30	79	21862	10049				
NC8306J-1	557	40	81	22053	10240				
NC8306JL-1	556	40	78	22706	10893				
NC8306K-1	582	50	82	22969	11156				

**NOTE**

- Use this bulletin for preliminary layouts only. Obtain current drawings from your Marley sales representative. All table data is per cell.
- Last numeral of model number indicates number of cells. Change as appropriate for your selection.
- Nominal tons are based upon 95°F HW, 85°F CW, 78°F WB and 3 GPM/ton.
- Standard overflow is a 4" dia. standpipe in the collection basin floor. The standpipe removes for flush-out and draining. See page 22 for side overflow option.
- Outlet sizes vary according to GPM and arrangement. See pages 22 and 23 for outlet sizes and details.
- Makeup water connection may be 1" or 2" dia., depending upon tower heat load, water pressure, and desired connections. See page 17 for additional information.

# SYSTEM CONNECT

## DUAL INLET CONNECTION

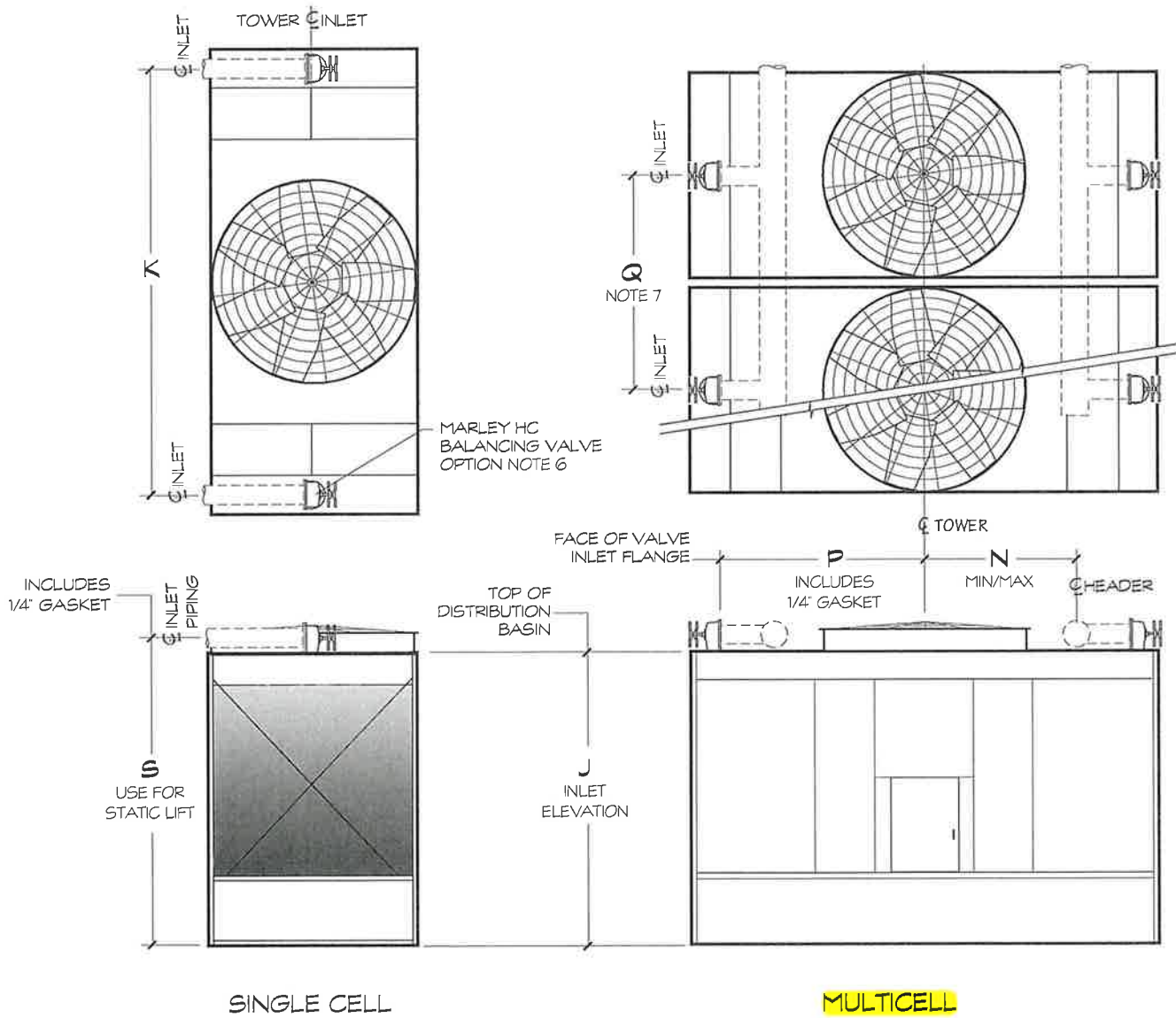

SINGLE CELL

MULTICELL

Tower Model	DIMENSIONS						Inlet Diameter	
	J	K	S	N MIN/MAX		P		Q
NC8301	8'-8 1/16"	12'-3"	9'-4 15/16"	3'-11 1/2"	4'-10"	5'-10"	6'-8 1/4"	2 at 6"
NC8302	8'-8 1/16"	13'-9"	9'-4 15/16"	5'-10 1/4"	Fit "P"	6'-7"	8'-2 1/4"	2 at 6"
NC8303	10'-5 9/16"	13'-9"	11'-1 13/16"	5'-10 1/4"	Fit "P"	6'-7"	8'-2 1/4"	2 at 6"
NC8304	11'-5 9/16"	15'-3"	12'-1 13/16"	5'-10 1/4"	Fit "P"	7'-4"	9'-2 1/4"	2 at 6"
<b>NC8305</b>	<b>11'-5 9/16"</b>	<b>16'-10"</b>	<b>12'-2 13/16"</b>	<b>5'-11 3/4"</b>	<b>Fit "P"</b>	<b>8'-1 1/2"</b>	<b>11'-2 1/4"</b>	<b>2 at 8"</b>
NC8306	11'-5 9/16"	17'-11"	12'-2 13/16"	6'-1 5/8"	Fit "P"	8'-8"	12'-2 1/4"	2 at 8"
NC8307	11'-9 9/16"	20'-6"	12'-6 13/16"	6'-1 5/8"	Fit "P"	9'-11 1/2"	12'-2 1/4"	2 at 8"
NC8309	11'-9 9/16"	20'-3 1/2"	12'-8 13/16"	6'-10 5/8"	Fit "P"	9'-9 1/2"	14'-2 1/4"	2 at 10"

# SYSTEM CONNECT

## OUTLET CONNECTION

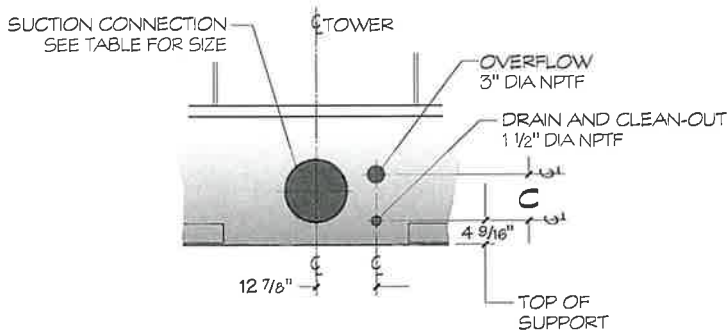

DRAIN AND OVERFLOW CONNECTION  
OPTION

Tower Model	DIMENSIONS		
	A	B	C
NC8301	10"	3'-3 3/16"	6 7/8"
NC8302	10"	4'-0 3/16"	6 7/8"
NC8303	10"	4'-0 3/16"	6 7/8"
NC8304	10"	4'-6 3/16"	6 7/8"
NC8305	10"	5'-6 3/16"	6 7/8"
NC8306	10"	6'-0 3/16"	6 7/8"
NC8307	11 1/4"	6'-0 3/16"	10 3/16"
NC8309	11 1/4"	7'-0 3/16"	10 3/16"
NC8310	11 1/4"	5'-6 3/16"	10 3/16"
NC8311	11 1/4"	6'-0 3/16"	10 3/16"
NC8312	11 1/4"	7'-0 3/16"	10 3/16"

NOTE

Standard overflow is a 4" dia. standpipe in the collection basin floor. The standpipe removes for flush-out and draining.

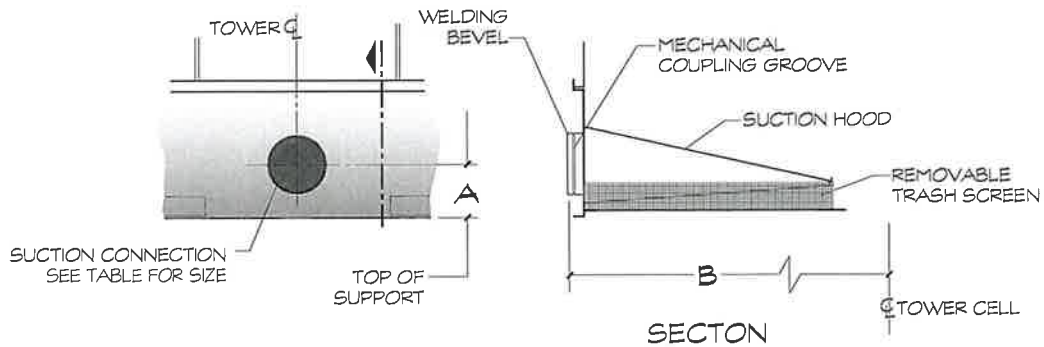

SIDE-OUTLET SUCTION CONNECTION

# TOWER SUPPORT

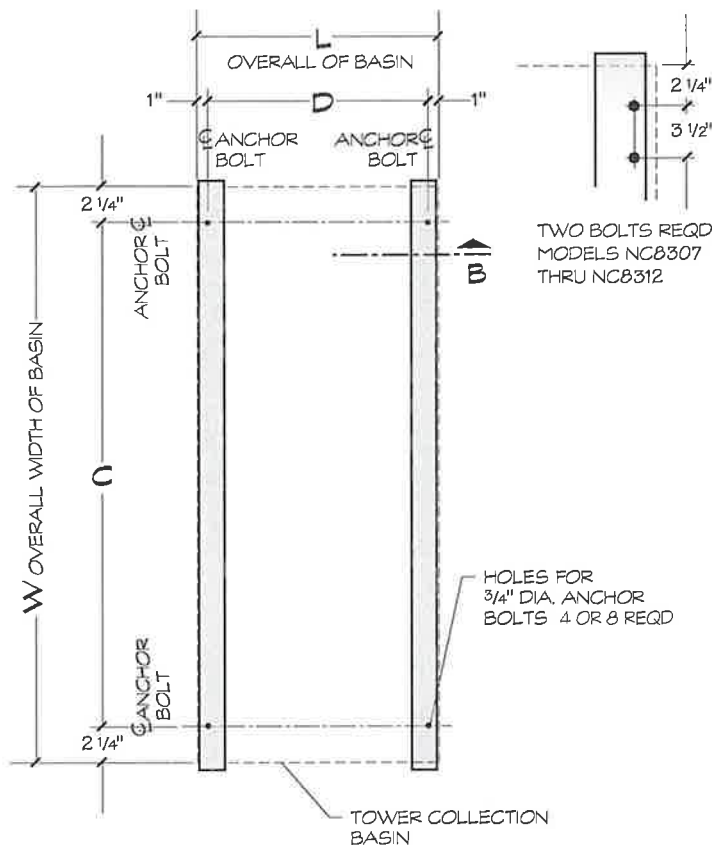

**SUPPORTING STEEL**  
SINGLE CELL

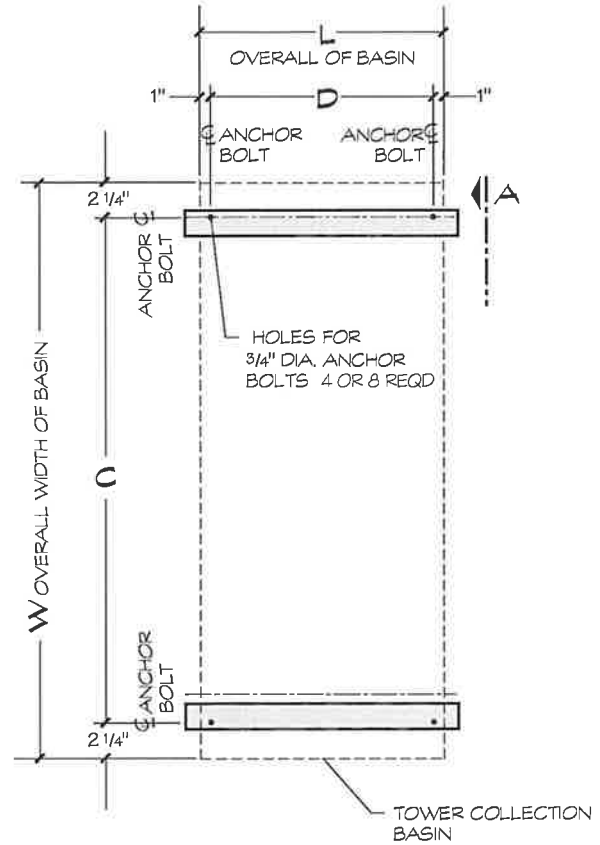

**SUPPORTING STEEL ALTERNATE**  
SINGLE CELL

Tower Model	DIMENSIONS					Design Operating Wt/Cell lb	Design Operating Load at Anchor lb	Wind/Seismic Loads lb Note 4	
	W	L	C	D	E Note 7			Max. Vertical Reaction at Anchor	Max. Horizontal Reaction at Anchor
NC8301	14'-0" 4268mm	6'-4 3/4" 1950mm	13'-7 1/2" 4153mm	6'-2 3/4" 1899mm	5 1/2" 140mm	8842	2211	1364/3461	943/2278
NC8302	15'-6" 4725mm	7'-10 3/4" 2407mm	15'-1 1/2" 4611mm	7'-8 3/4" 2356mm	5 1/2" 140mm	11256	2814	1221/3399	1046/2767
NC8303	15'-6" 4725mm	7'-10 3/4" 2407mm	15'-1 1/2" 4611mm	7'-8 3/4" 2356mm	5 1/2" 140mm	12022	3006	1737/4622	1248/3005
NC8304	17'-0" 5182mm	8'-10 3/4" 2712mm	16'-7 1/2" 5068mm	8'-8 3/4" 2661mm	5 1/2" 140mm	14463	3616	2019/5979	1498/3675
<b>NC8305</b>	<b>18'-9" 5715mm</b>	<b>10'-10 3/4" 3321mm</b>	<b>18'-4 1/2" 5601mm</b>	<b>10'-8 3/4" 3271mm</b>	<b>5 1/2" 140mm</b>	<b>18958</b>	<b>4740</b>	<b>1803/8606</b>	<b>1648/4877</b>
NC8306	19'-10" 6046mm	11'-10 3/4" 3626mm	19'-5 1/2" 5931mm	11'-8 3/4" 3576mm	5 1/2" 140mm	22969	5742	1759/9965	1750/5742
NC8307	22'-5" 6833mm	11'-10 3/4" 3626mm	22'-0 1/2" 6719mm	11'-8 3/4" 3576mm	5 1/2" 140mm	27256	6814	2090/8624	2029/6814
NC8309CL thru NC8309JL	22'-5" 6833mm	13'-10 3/4" 4236mm	22'-0 1/2" 6719mm	13'-8 3/4" 4185mm	5 1/2" 140mm	32097	8024	1801/10170	2037/7925
NC8309K and NC8309KL	22'-5" 6833mm	13'-10 3/4" 4236mm	22'-0 1/2" 6719mm	13'-8 3/4" 4185mm	5 1/2" 140mm	32261	8065	2271/10516	2256/8065
NC8310C thru NC8310H	22'-5" 6833mm	10'-10 3/4" 3321mm	22'-0 1/2" 6719mm	10'-8 3/4" 3271mm	5 1/2" 140mm	34087	8522	5405/16343	3121/8631
NC8310K	22'-5" 6833mm	10'-10 3/4" 3321mm	22'-0 1/2" 6719mm	10'-8 3/4" 3271mm	1'-0 3/4" 324mm	34330	8583	5606/16343	3304/8631
NC8311AL thru NC8311J	22'-5" 6833mm	11'-10 3/4" 3626mm	22'-0 1/2" 6719mm	11'-8 3/4" 3576mm	5 1/2" 140mm	37058	9265	4958/17503	3126/9286
NC8311K and NC8311KL	22'-5" 6833mm	11'-10 3/4" 3626mm	22'-0 1/2" 6719mm	11'-8 3/4" 3576mm	1'-0 3/4" 324mm	37305	9326	5779/18328	3353/9630
NC8312BL thru NC8312JL	22'-5" 6833mm	13'-10 3/4" 4236mm	22'-0 1/2" 6719mm	13'-8 3/4" 4185mm	5 1/2" 140mm	42981	10745	4248/21064	3131/10745
NC8312K thru NC8312R	22'-5" 6833mm	13'-10 3/4" 4236mm	22'-0 1/2" 6719mm	13'-8 3/4" 4185mm	5 1/2" 140mm	44427	10607	4971/21932	3364/11107

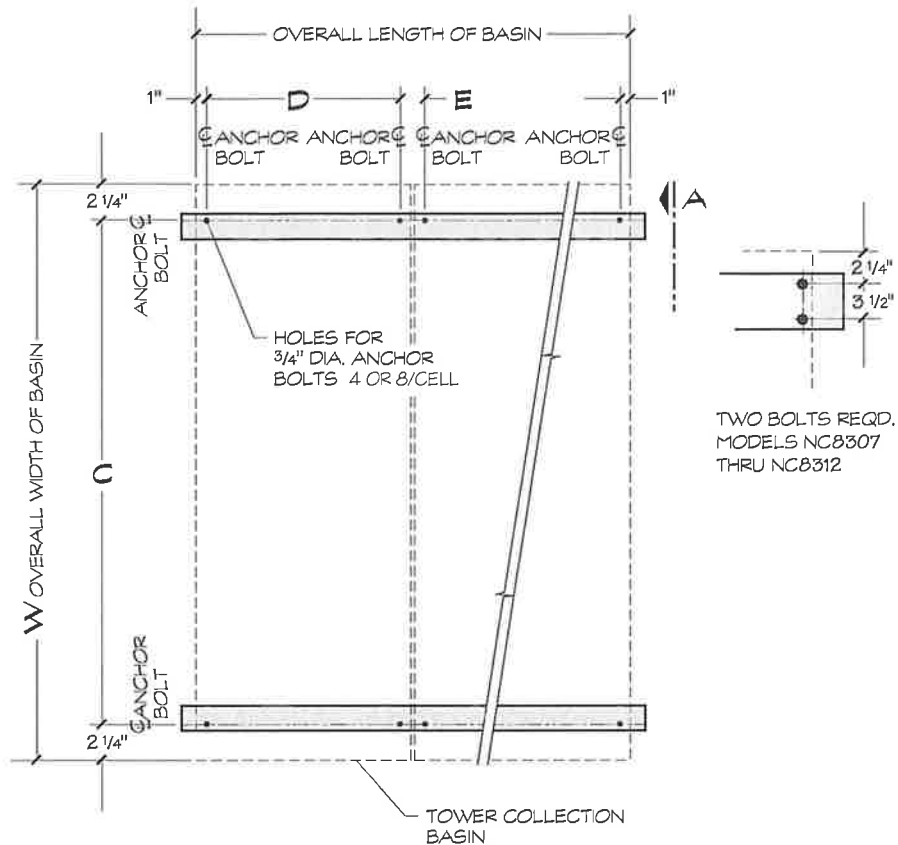

TWO BOLTS REQD.  
MODELS NC8307  
THRU NC8312

**SUPPORTING STEEL**  
**MULTICELL**

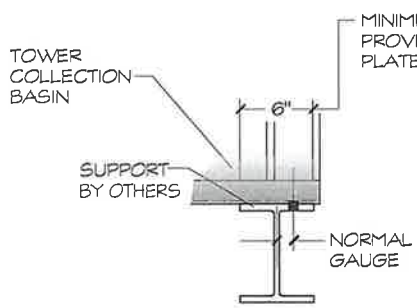

VIEW A

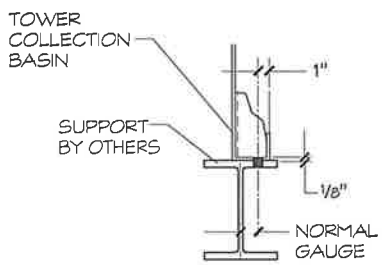

SECTION B

**NOTE**

- 1 Use this bulletin for preliminary layouts only. Obtain current drawings from your Marley sales representative for final design.
- 2 Purchaser to provide tower support complete with holes and anchor bolts. Do not use studs! Anchor points must be framed flush and level at top.
- 3 Design operating weight occurs with collection basin full to overflow level. Actual operating weight varies with GPM and piping scheme.
- 4 Wind loads are based on 30 psf and are additive to operating loads. Seismic loads will satisfy Zone 2B with importance factor of 1.0 per the 1997 UBC. Seismic reactions shown are for a 1g acceleration and may be factored down.
- 5 Tower may be placed on a flat concrete slab. Side outlet and optional side drain and overflow must be specified. See pages 16 and 22 and consult your Marley sales representative.
- 6 Tower may be supported from piers at each anchor bolt location, as a support alternative.
- 7 Dimensions between anchor bolts "E" may vary depending on the number of cells and options. Dimensions shown are for a standard two cell arrangement. Obtain current drawings from your Marley sales representative for final dimension.

# EXHIBIT C

# Document A310™ – 2010

Conforms with The American Institute of Architects AIA Document 310

## Bid Bond

### CONTRACTOR:

(Name, legal status and address)

DePue Mechanical, Inc.  
P. O. Box 857  
Minooka, IL 60447

### SURETY:

(Name, legal status and principal place of business)

The Cincinnati Insurance Company  
P.O. Box 145496  
Cincinnati, OH 45250-5496  
**Mailing Address for Notices**  
Same as above

This document has important legal consequences. Consultation with an attorney is encouraged with respect to its completion or modification.

### OWNER:

(Name, legal status and address)

Minooka Community High School District 111  
26655 W. Eames Street  
Channahon, IL 60410

Any singular reference to Contractor, Surety, Owner or other party shall be considered plural where applicable.

**BOND AMOUNT:** 10% Ten Percent of Amount Bid

### PROJECT:

(Name, location or address, and Project number, if any)

Water Cooling Tower Replacement

The Contractor and Surety are bound to the Owner in the amount set forth above, for the payment of which the Contractor and Surety bind themselves, their heirs, executors, administrators, successors and assigns, jointly and severally, as provided herein. The conditions of this Bond are such that if the Owner accepts the bid of the Contractor within the time specified in the bid documents, or within such time period as may be agreed to by the Owner and Contractor, and the Contractor either (1) enters into a contract with the Owner in accordance with the terms of such bid, and gives such bond or bonds as may be specified in the bidding or Contract Documents, with a surety admitted in the jurisdiction of the Project and otherwise acceptable to the Owner, for the faithful performance of such Contract and for the prompt payment of labor and material furnished in the prosecution thereof; or (2) pays to the Owner the difference, not to exceed the amount of this Bond, between the amount specified in said bid and such larger amount for which the Owner may in good faith contract with another party to perform the work covered by said bid, then this obligation shall be null and void, otherwise to remain in full force and effect. The Surety hereby waives any notice of an agreement between the Owner and Contractor to extend the time in which the Owner may accept the bid. Waiver of notice by the Surety shall not apply to any extension exceeding sixty (60) days in the aggregate beyond the time for acceptance of bids specified in the bid documents, and the Owner and Contractor shall obtain the Surety's consent for an extension beyond sixty (60) days.

If this Bond is issued in connection with a subcontractor's bid to a Contractor, the term Contractor in this Bond shall be deemed to be Subcontractor and the term Owner shall be deemed to be Contractor.

When this Bond has been furnished to comply with a statutory or other legal requirement in the location of the Project, any provision in this Bond conflicting with said statutory or legal requirement shall be deemed deleted herefrom and provisions conforming to such statutory or other legal requirement shall be deemed incorporated herein. When so furnished, the intent is that this Bond shall be construed as a statutory bond and not as a common law bond.

Signed and sealed this 12th day of April, 2024.

  
\_\_\_\_\_  
(Witness)

DePue Mechanical, Inc.  
\_\_\_\_\_  
(Principal) (Seal)

By:   
\_\_\_\_\_  
(Title) VP of Business Development

The Cincinnati Insurance Company  
\_\_\_\_\_  
(Surety) (Seal)

By:   
\_\_\_\_\_  
(Title) Quanda Warren, Attorney-in-Fact



THE CINCINNATI INSURANCE COMPANY  
THE CINCINNATI CASUALTY COMPANY

Fairfield, Ohio

POWER OF ATTORNEY

KNOW ALL MEN BY THESE PRESENTS: That THE CINCINNATI INSURANCE COMPANY and THE CINCINNATI CASUALTY COMPANY, corporations organized under the laws of the State of Ohio, and having their principal offices in the City of Fairfield, Ohio (herein collectively called the "Companies"), do hereby constitute and appoint **Quanda Warren** its true and legal Attorney-in-Fact to sign and deliver on behalf of the Companies as Surety, at any place within the United States, the following surety bond:

Surety Bond Number: Bid Bond  
Principal: DePue Mechanical, Inc.  
Obligee: Minooka Community High School District 111

This appointment is made under and by authority of the following resolutions adopted by the Boards of Directors of The Cincinnati Insurance Company and The Cincinnati Casualty Company, which resolutions are now in full force and effect, reading as follows:

RESOLVED, that the President or any Senior Vice President be hereby authorized, and empowered to appoint Attorneys-in-Fact of the Company to execute any and all bonds, policies, undertakings, or other like instruments on behalf of the Corporation, and may authorize any officer or any such Attorney-in-Fact to affix the corporate seal; and may with or without cause modify or revoke any such appointment or authority. Any such writings so executed by such Attorneys-in-Fact shall be binding upon the Company as if they had been duly executed and acknowledged by the regularly elected officers of the Company.

RESOLVED, that the signature of the President or any Senior Vice President and the seal of the Company may be affixed by facsimile on any power of attorney granted, and the signature of the Secretary or Assistant Vice-President and the Seal of the Company may be affixed by facsimile to any certificate of any such power and any such power of certificate bearing such facsimile signature and seal shall be valid and binding on the Company. Any such power so executed and sealed and certified by certificate so executed and sealed shall, with respect to any bond or undertaking to which it is attached, continue to be valid and binding on the Company.

IN WITNESS WHEREOF, the Companies have caused these presents to be sealed with their corporate seals, duly attested by their President or any Senior Vice President this 16th day of March, 2021.



STATE OF OHIO )SS:  
COUNTY OF BUTLER )

THE CINCINNATI INSURANCE COMPANY  
THE CINCINNATI CASUALTY COMPANY

*Stephen A. Ventre*

On this 16th day of March, 2021 before me came the above-named President or Senior Vice President of The Cincinnati Insurance Company and The Cincinnati Casualty Company, to me personally known to be the officer described herein, and acknowledged that the seals affixed to the preceding instrument are the corporate seals of said Companies and the corporate seals and the signature of the officer were duly affixed and subscribed to said instrument by the authority and direction of said corporations.



*Keith Collett*  
Keith Collett, Attorney at Law  
Notary Public – State of Ohio  
My commission has no expiration date.  
Section 147.03 O.R.C.

I, the undersigned Secretary or Assistant Vice-President of The Cincinnati Insurance Company and The Cincinnati Casualty Company, hereby certify that the above is the Original Power of Attorney issued by said Companies, and do hereby further certify that the said Power of Attorney is still in full force and effect.

Given under my hand and seal of said Companies at Fairfield, Ohio, this 12th day of April, 2024.



*Ed H.*



March 27, 2024

Mr. John Troy  
Assistant Superintendent & General Counsel  
Minooka Community High School District#111  
301 S Wabena Ave  
Minooka, Illinois 60447

*Via Email at: [jtroy@mchs.net](mailto:jtroy@mchs.net)*

**RE: Proposal for Asbestos Abatement Design  
Gymnasium – Minooka High School  
Minooka, IL**

Dear Mr. Troy,

TRC Environmental Corporation (TRC) is pleased to present this proposal to Minooka Community High School District#111 (hereinafter referred to as the “Client”) to perform an asbestos abatement design of the abatement area in the gymnasium at the above-referenced subject property. Please find below our project understanding, anticipated project scope, fees, proposed project schedule, and business terms.

#### **SCOPE OF WORK**

The asbestos abatement design will include the following:

- Development of technical asbestos abatement specifications that are compliant with all Illinois Department of Public Health (IDPH), EPA, and OSHA regulations.
- Drawings of the asbestos abatement work area in the gymnasium including negative air locations, water, electric, negative air discharge locations, asbestos locations, etc.
- Clearance sampling methodology and criteria.
- Work practices.
- Containment and work area specifications.
- Abatement contractor bidding documents.

#### **FEES**

The total cost estimate for the project is **\$2,607.00**, unless additional tasks or mobilizations are required, and will be invoiced as lump sum. TRC will inform Client of the anticipated costs of completing any additional work prior to completion of the additional work.

#### **ASSUMPTIONS**

The following assumptions provide the basis upon which TRC’s proposed costs were developed for the project:

- No delays beyond TRC’s control are encountered in performing the scope of work during the scheduled site visit day(s). TRC will have timely, complete and unobstructed access to the subject property, as applicable to perform the requested scope of work.
- The scope is limited to the Gymnasium only.

- Any activities beyond those specified in the scope of work will be considered supplemental services and will be invoiced on a time-and-material basis or covered under a separate, written proposal. However, no such services will be undertaken without Client's authorization.

**AUTHORIZATION**

TRC will initiate project activities upon receipt of written authorization from you. If this proposal meets with your approval, please indicate your authorization to proceed by signing and returning one copy of this letter proposal in the authorization block below and at the end of the attached TRC General Terms and Conditions for Services, which are part of this proposal, or by returning a purchase order or contract with mutually agreeable terms and conditions. The receipt of the signed document by TRC will serve as our authorization to proceed with the scope of work described in this proposal. It is assumed that the project will be scheduled within a mutually agreed upon time frame.

**CLOSING**

TRC appreciates the opportunity to be of service to Minooka Community High School District #111 on this project. If you have any questions regarding this proposal, please contact the undersigned at (847) 721-7582

Respectfully submitted,

  
Mitchell Pendergrass  
Central Region Practice Leader

  
Jeff Voorhees  
Sr. Project Manager

This Agreement is effective on the last day signed.

**TRC ENVIRONMENTAL CORPORATION**

**CLIENT**

By:   
Name: Mitchell Pendergrass  
Title: Central Region Practice Leader  
Date: 03/27/24

By:   
Name: John Troy  
Title: Asst. Supt + Gen. Counsel  
Date: 4/4/24



## TERMS AND CONDITIONS

These Terms and Conditions are incorporated into the proposal to which these Terms and Conditions are attached (the “**Proposal**”). The term “**TRC**” herein shall mean the entity submitting the proposal. The term “**Client**” herein shall mean the person or entity for whom the Work will be performed. Sometimes herein Client and TRC are referred to individually as a “**Party**” and collectively as the “**Parties**.” As used herein, the term “**Affiliate**” means any direct or indirect, current or future, subsidiary of a Party, or any other entity which is controlled by a Party, or which controls a Party directly or through one or more intermediary. The term “**control**” as used in the prior sentence means possession, directly or indirectly, of at least fifty percent (50%) of the voting equity of another entity (or other comparable interest for an entity other than a corporation), or the power to direct or cause the direction of the management or policies of an entity, whether through ownership of securities, by contract, or otherwise.

### ARTICLE 1. WORK, AGREEMENT DOCUMENTS, AND PROJECT INFORMATION

- 1.1 **Work, Deliverables, Materials.** TRC will perform the consulting, engineering, and/or other professional services (the “**Work**”), provide the Deliverables (defined below in Section 12.1), and/or procure the materials and/or equipment (“**Materials**”), as set forth in detail in the Proposal.
- 1.2 **Agreement Documents.** These Terms and Conditions, together with the Proposal, form the Agreement pursuant to which TRC will perform. If Client issues a purchase order or similar document authorizing the Work (“**Client Authorization**”), any pre-printed terms included in any Client Authorization shall be of no effect and are expressly excluded from this Agreement.
- 1.3 **Interpretation.** In the event of any conflict or inconsistency between or among any of the Agreement Documents, these Terms and Conditions shall take precedence, followed by the Proposal, unless expressly stated otherwise herein or in the Proposal. In the event of any conflict or inconsistency between or among the terms or conditions established in a Change Order or amendment and the Agreement, the terms of such Change Order or amendment will take precedence over those of the Agreement. No other terms or conditions shall be applicable to the Work.
- 1.4 **Defined Terms.** Some capitalized terms used in the Agreement may be defined in the Proposal. Any term defined in the Proposal will have the same meaning throughout the Agreement, and any term defined in the Agreement will have the same meaning in the Proposal. As used herein, the term “**day**” means “**calendar day**.”

### ARTICLE 2. COMPENSATION AND INVOICING

- 2.1 **Compensation.** Client shall pay the Contract Price set forth in the Proposal.
- 2.2 **Invoicing.** TRC will bill for its Work, and Client shall compensate TRC, as provided in the Proposal. TRC will submit monthly invoices for Work rendered and expenses incurred in the prior month.
  - (a) **Time and Expense.** Any Work performed on a time and expense or time and materials basis will be invoiced as follows:
    - (i) Rates shall be as set forth in the Proposal. Rates are subject to increase on an annual basis.
    - (ii) TRC will keep accurate and daily records of all labor, equipment, and materials furnished. TRC will summarize daily records on a weekly and/or monthly basis and will submit for review upon Client’s written request.
    - (iii) **Reimbursable Expenses:**
      - **Project Expenses.** Expenses reasonably incurred in connection with the Work will be invoiced at 6% of Labor (includes in-house reproduction, office materials, telecommunications, standard software, postage, computer expenses, and field expendables).
      - **Insurance.** A charge of 2% will be applied to all invoiced amounts for the cost of TRC’s insurance coverage.
      - **Subcontractors.** A fee of 15% will be added to the invoice cost of subcontracts managed by TRC —
      - **Client Requested Expenses.** Outside services such as, but not limited to, outside reprographic services, materials, and equipment, will be invoiced at cost plus 10%.
      - **Mileage.** Personal automobile travel from portal to portal or between locations will be charged at current IRS mileage rates per mile.
      - **Travel Expenses.** Airfare, car rental, taxi, parking, tolls, and incidental expenses will be invoiced at cost plus 10%, with receipts provided for any expense over \$25.00.
      - **Lodging and Meals.** Lodging and meals will be charged either:
        - o at cost plus 10%, with receipts provided for any expense over \$25.00, or
        - o on a per diem basis, using the GSA per diem rates found here: <https://www.gsa.gov/travel/plan-book/per-diem-rates>. When lodging and meals are charged on a per diem basis, a flat per diem rate will be charged and receipts will not be provided for actual lodging and meal expenses.
    - (iv) Unless otherwise stated, the Contract Price does not include any present or future federal, state, or local property, license, privilege, sales, use, excise, gross receipts or other like taxes or assessments which may be applicable to, measured by, imposed upon, or resulting from the performance of the Work.
  - (b) **Lump Sum or Unit Prices.** If Work is performed on a lump sum or unit price basis, TRC will invoice on the schedule provided for in the Proposal or, if no invoicing schedule is included in the Proposal, based on percentage of completion of Work or number of units completed, as applicable.
  - (c) **Disputed Invoices.** If Client objects to all or any portion of an invoice, it must notify TRC in writing detailing the nature of the objection within seven (7) days from the date of receipt of the invoice, and must pay any undisputed portion of the invoice as provided in Section 2.3 below. The Parties will confer immediately after Client advises of a dispute and the Parties will make every effort to immediately resolve the disputed portion of the invoice. If the Parties fail to reach

4/4/24



agreement at the project level on a disputed invoice within thirty (30) days of the date of the invoice, either Party has the option of proceeding in accordance with Article 15, Dispute Resolution.

- 2.3 **Payment Terms.** Except as provided in Section 2.2(c) above, Client must pay all invoices as set forth in the remittance instructions in Section 16.12 below no later than thirty (30) days after the date of the invoice.
- 2.4 **Failure to Pay.** Except as provided in Section 2.2(c) above, interest will accrue on all delinquent payments at the rate of 1.5% per month, or the highest rate permissible under applicable law, whichever is less, starting on the 31<sup>st</sup> day after the date of an invoice. Additionally, if Client does not pay TRC within forty-five (45) days of the date of an invoice, then, upon seven (7) days' written notice to Client, TRC may suspend performance of the Work and any Deliverables until it receives payment of the amount owing. Additionally, Client will reimburse TRC for all reasonable costs incurred by TRC in collecting any overdue payments and related interest, including, without limitation, reasonable attorneys' fees, other legal costs, court costs, and collection agency fees.
- 2.5 **Records/Audit.** TRC will keep complete and accurate records in accordance with generally accepted accounting practices with respect to all amounts invoiced by TRC under this Agreement. TRC will keep such records pertaining to each invoice for two (2) years after the date of the invoice. If an audit is commenced within such two (2) year period, Client must provide TRC with advance written notice of the audit, such audit may only be performed during normal business hours, and such audit shall not extend to TRC's overhead, markups, profit/loss information, fixed rates, unit prices, prices expressed as percentages, efficiency in performing Work, or any trade secrets.

### ARTICLE 3. TIME FOR PERFORMANCE

- 3.1 **Time for Performance.** TRC will use commercially reasonable efforts to perform the Work within the Contract Time stated in the Proposal to the extent consistent with the terms of this Agreement, the Standard of Care defined below, and the orderly progress of the Work.
- 3.2 **Completion.** TRC's Work will be considered complete at the earlier of: (i) the date when TRC's Deliverables are reasonably accepted by Client; or (ii) thirty (30) days after the date when the last of TRC's Deliverables are submitted for final acceptance if Client does not notify TRC in writing within such 30-day period that the Deliverables fail to conform to the requirements of the Agreement.

### ARTICLE 4. ADDITIONAL AND CHANGED WORK, DELAYS

- 4.1 **Work Added or Changed by Client.** Client shall provide TRC with an equitable adjustment in compensation and time for performance for any Work added or changed by Client. Any changes or additions to the Work shall be set forth in a written document signed by both Parties ("Change Order"). TRC has no obligation to proceed with changed or additional work until the Parties execute a Change Order.
- 4.2 **Force Majeure Events.** No Party will be liable or responsible to the other Party, nor be deemed to have defaulted under this Agreement, for any failure or delay in fulfilling or performing any term of this Agreement (except for any obligations to make payments to the other Party hereunder), to the extent such failure or delay is caused by a Force Majeure Event. The term "Force Majeure Event" means any event which: (a) is not within the reasonable control of the affected Party; and (b) causes the affected Party to be delayed in performance of, or unable to perform, its obligations under this Agreement. Subject to the foregoing, Force Majeure Events include, but are not limited to: drought; fire; flood; extreme weather conditions; earthquake; lightning; epidemic; war (whether declared or undeclared); acts of terrorism, or damage resulting therefrom; acts of God or the public enemy; explosion; rebellion; riot; civil disturbance; sabotage; vandalism; actions of third parties; actions of a court or other governmental entity; actions of, or failure to act by, regulatory agencies; strikes or other concerted acts of workers; accidents in shipping or transportation; and the closing or congestion (beyond reasonably foreseeable levels) in any harbor, dock, port, canal, or other adjunct of the shipping or navigation of or within any place; or pandemic, epidemic, or governmental activity in response to such pandemic or epidemic that impacts a Party's ability to perform. The Party affected by a Force Majeure Event: (i) must promptly notify the other Party by email; (ii) is relieved from fulfilling its contractual obligations during the continuance of the Force Majeure Event to the extent the inability to perform is caused by the Force Majeure Event; (iii) as soon as reasonably possible after the Force Majeure, must fulfill or resume fulfilling its obligations hereunder; (iv) must promptly notify the other Party by email of the cessation or partial cessation of the Force Majeure Event; and (v) will be entitled to equitable compensation and an equitable adjustment of the Contract Time to neutralize the effect of the Force Majeure Event. Within a reasonable time after cessation of the Force Majeure Event, any Party claiming additional time and/or compensation must provide the other Party with supporting information to substantiate its position. If the Parties fail to reach agreement at the project level on an amendment or a Change Order within thirty (30) days of the submission of supporting information, either Party has the option of proceeding in accordance with Article 15, Dispute Resolution.
- 4.3 **Impacts to the Work.** TRC will be entitled to equitable compensation for, and an equitable adjustment of the Contract Time, to the extent the Work is impacted by any additional or changed Work as a result of any actions or circumstances not the fault of TRC, including, but not limited to: a failure of Client to perform or cause performance of its obligations in accordance with the Agreement, including, but not limited to, failure to provide necessary access or Information (defined below); failure to provide necessary comments in connection with the development of any Deliverables (defined below); interference with or delay of any Work caused by Client, or other party for whom Client is responsible; any error, omission, or ambiguity in Information; changes in site conditions; delays in obtaining, or the absence, suspension, termination, or failure of renewal of, any permit, license, or governmental authorization; and encountering any unforeseen conditions.
- 4.4 **Notice of Impacts to the Work.** Whenever TRC discovers an event or a condition has impacted its Work so as to constitute a basis for a change in compensation or schedule, TRC will notify Client by email promptly after discovery of the event or condition, advising Client of the nature of the impact and requesting a Change Order. Within a reasonable time thereafter, TRC will provide Client supporting information to substantiate TRC's position. If the Parties fail to reach agreement at the project level on a Change Order request within thirty (30) days' of TRC's submission of supporting information, either Party has the option of proceeding in accordance with Article 15, Dispute Resolution.
- 4.5 **Delays by TRC.** If the Work is not progressing in accordance with the project schedule due to TRC's fault, TRC will take appropriate corrective measures to recover the schedule at TRC's expense, to the extent the delays are caused by TRC's fault.

**ARTICLE 5. CLIENT'S RESPONSIBILITIES**

- 5.1 **Client Information.** Client will furnish to TRC all existing studies, reports, surveys, inspections, Project Site evaluations, data, and other information available or that becomes available to Client and pertinent to TRC's performance of the Work ("**Information**"), authorize TRC to obtain additional Information as required; and furnish the services of others where necessary for the performance of the Work. TRC will be entitled to use and rely on the completeness and accuracy of all such Information.
- 5.2 **Access.** Where necessary for performance of the Work, Client will arrange for TRC access to any site or property.
- 5.3 **Subsurface Investigations.** If the Work involves subsurface investigation, excavation, or drilling, Client must provide TRC with assistance in locating underground structures or utilities in the vicinity of any such activities. If despite commercially appropriate practices neither Client nor TRC can confirm the location of such underground structures or utilities, Client agrees that TRC is not responsible for any costs associated with, and accepts all liability and costs associated with, the repair, replacement, or restoration of any damage caused by the performance of the Work.
- 5.4 **Communication.** Client will designate an authorized representative who will be responsible for communications and consultation with TRC and who will have the authority to make decisions necessary for TRC to perform its Work.

**ARTICLE 6. TRC'S OBLIGATIONS AND WARRANTY**

- 6.1 **Standard of Care.** TRC will perform the Work consistent with the professional skill and care ordinarily provided by the same type of professional, for a project of similar size, scope, and complexity during the time which the Work is provided, and in a similar locality, under similar circumstances ("**Standard of Care**").
- 6.2 **Warranty for Materials.** In the event TRC procures Materials pursuant to this Agreement, TRC warrants to Client that the Materials will be new and free of defects in workmanship ("**Warranty**").
- 6.3 **Remedies.** If TRC's Work fails to meet the Standard of Care ("**Nonconforming Work**"), or if any Materials fail to meet the Warranty ("**Defective Materials**"), and if Client provides written notice to TRC of such failure no later than one (1) year after completion of the Work ("**Correction Period**"), at TRC's option TRC will within a reasonable time after receipt of written notice: (a) re-perform the Non-conforming Work; (b) repair or replace the Defective Materials; or (c) refund the amount of compensation paid to TRC for such Non-conforming Work and/or Defective Materials. Client will provide TRC access to the Project Site so TRC can perform its obligations under this Section 6.3.
- 6.4 **Warranty Limitation.** THE STANDARD OF CARE IS NOT A WARRANTY OR GUARANTEE, AND TRC HAS NO SUCH OBLIGATION, EXPRESS OR IMPLIED, WITH RESPECT TO PROFESSIONAL SERVICES. NOTHING IN THIS AGREEMENT WILL BE INTERPRETED TO REQUIRE TRC TO PERFORM PROFESSIONAL SERVICES TO ANY HIGHER STANDARD OR HAVE ANY OBLIGATION IN THE PERFORMANCE OF PROFESSIONAL SERVICES IN EXCESS OF WHAT IS REQUIRED BY THE STANDARD OF CARE, AND THIS SECTION WILL CONTROL OVER ANY CONTRARY PROVISION. OTHER THAN THE EXPRESS WARRANTIES CONTAINED HEREIN, TRC DISCLAIMS ALL WARRANTIES, WHETHER STATUTORY, EXPRESS, OR IMPLIED, INCLUDING ALL WARRANTIES OF MERCHANTABILITY AND FITNESS FOR A PARTICULAR PURPOSE, AND ALL WARRANTIES ARISING FROM COURSE OF DEALING OR USAGE IN TRADE. SUBJECT TO TRC'S LIABILITY UNDER SECTION 9.2, CLIENT'S EXCLUSIVE REMEDIES AND TRC'S ONLY OBLIGATIONS ARISING OUT OF A CLAIM FOR NONCONFORMING WORK AND/OR DEFECTIVE MATERIALS FOLLOWING SUBSTANTIAL COMPLETION OF THE WORK WILL BE THOSE STATED IN THIS ARTICLE 6.
- 6.5 **Licenses.** TRC will obtain in TRC's name the known licenses, permits, or other approvals from any governmental agency or regulatory body that are necessary for TRC to perform the Work.
- 6.6 **Resources.** TRC will obtain all tools, equipment, materials, software, and licenses that are necessary for TRC to perform the Work.
- 6.7 **Employees.** TRC will employ, discharge, pay, control, and direct its employees. TRC will employ only skilled professionals for Work requiring special qualifications.
- 6.8 **Inspections.** If the Work includes inspections during or after construction based upon TRC-prepared drawings or specifications, notwithstanding anything to the contrary herein, consistent with the Standard of Care, TRC will visit the Project Site at intervals appropriate to the state of the contractor's operations, or as specifically provided in TRC's Work, (1) to become generally familiar with and to keep Client informed about the progress and quality of the portion of the construction work completed, (2) to endeavor to guard Client against defects and deficiencies in the construction work, and (3) to determine in general if the construction work is being performed in a manner indicating that, when fully completed, will be in accordance with the applicable contract documents, but the sole responsibility for compliance with drawings and specifications will be with the entity performing the construction. TRC shall not have control of, nor be in charge of, nor shall be responsible for, the means, methods, techniques, sequences, procedures, construction, or safety precautions and programs in connection with any construction work, as these are solely the construction contractor's rights and responsibilities. Furthermore, TRC shall not be responsible for the failure of Client, or any party under contract with Client, including, but not limited to, any architect, engineer, consultant, contractor, or subcontractor, to carry out their respective responsibilities in accordance with their legal and contractual obligations.
- 6.9 **Communication.** TRC will designate an authorized representative who will be responsible for communications and consultation with Client and who will have the authority to make decisions necessary for TRC to perform its Work. TRC will advise Client at regular intervals of the status of the Work.

**ARTICLE 7. CONFIDENTIALITY**

- 7.1 **Confidentiality Agreement.** The Party receiving Confidential Information may include that Party's Representatives ("**Recipient**"). The term "**Representatives**" means a Party's Affiliates and their respective employees, agents, subcontractors, and advisors. Recipient is not permitted to reveal Confidential Information (defined in Section 7.2 below) to any third party without written consent from an authorized representative of the Party disclosing the Confidential Information ("**Discloser**"). Notwithstanding the foregoing, Client acknowledges that TRC's review of Client's Confidential Information will inevitably enhance TRC's knowledge and understanding of Client's business in a way that cannot be separated from TRC's other knowledge, and Client agrees that this Agreement shall not restrict TRC in connection with the purchase, sale, or consideration of, or decisions related to, other investments.



- 7.2 **Confidential Information.** The term “**Confidential Information**” includes: (i) all non-public information, materials, or products developed pursuant to this Agreement; and (ii) information about a Party’s or its Representatives’ business affairs, employees, finances, client and supplier relationships, rates, pricing, means and methods of work, services, intellectual property, trade secrets, and other sensitive, marketing, or proprietary information, whether disclosed orally or in written, electronic, or other form or media. Notwithstanding the foregoing, however, Confidential Information shall not include the following: (i) information which at the time of disclosure is or becomes publicly available other than as a result of a disclosure by an act or omission of Recipient; (ii) information which is or becomes available to Recipient on a nonconfidential basis from a source (other than from Discloser) which is not prohibited from disclosing such information pursuant to a legal, contractual or fiduciary obligation to Discloser; (iii) information which was already known to Recipient; or (iv) information which is independently developed by Recipient.
- 7.3 **Legal Obligation to Disclose.** If Recipient is required by applicable law, regulation, or legal process to disclose any of the Confidential Information, Recipient will notify Discloser promptly so Discloser may (i) seek a protective order or other appropriate remedy, (ii) take action to assure confidential handling of such information, and/or (iii) in its sole discretion, waive compliance with the terms of this Agreement. In the event such protective order or other remedy is not obtained, or Discloser waives compliance with the terms hereof, Recipient (i) may so disclose only that portion of the Confidential Information which it is legally required to disclose and shall, upon request, reasonably assist Discloser with Discloser’s efforts to obtain reliable assurance that confidential treatment will be afforded such Confidential Information, and (ii) shall not be liable for such disclosure. Notwithstanding the foregoing, Client acknowledges that one or more of TRC’s Affiliates is a registered investment adviser and that TRC may be subject to routine examinations, investigations, regulatory sweeps, or other regulatory inquiries by applicable regulatory and self-regulatory authorities. Client agrees that TRC may make such disclosures as may be requested by any such authority (or examiner thereof) and will not be required to comply with the process described in this paragraph; provided that if the request by such authority (or examiner thereof) is specifically targeted at Client, TRC will notify Client (to the extent not prohibited by such authority or examiner or by applicable rule, regulation, or law) as promptly as practicable following such request.
- 7.4 **Remedy.** Each Party agrees the actual or threatened disclosure or use of any Confidential Information, other than as permitted under this Agreement, will cause irreparable harm to Discloser, and Discloser will be entitled, without prejudice or limit to any other remedy, to obtain injunctive relief to prevent such unauthorized use or disclosure.
- 7.5 **Communications with Third Parties.** To the extent the Work requires TRC to communicate with any third party including, but not limited to, owners of the Project Site or other locations, former employees, current employees, or government authorities, TRC shall so inform Client. For all such communications, Client releases TRC from claims of breach of confidentiality, waiver of privilege, or otherwise associated with any such communications.

#### ARTICLE 8. INSURANCE

- 8.1 **Required Insurance Coverage.** TRC will obtain and maintain insurance of the types and amounts set forth herein. The insurance will be in effect before Work commences, and will remain in effect until completion of the Work. TRC will require any subcontractors to obtain and maintain coverages appropriate to their scope of work. TRC will have the following insurance coverage:
- (a) **Worker’s Compensation Insurance and Employer’s Liability Insurance** as required by the law of the state in which the Project is located, but Employer’s Liability coverage will be in the amount of \$1,000,000 each accident;
  - (c) **Automobile Liability Insurance** in the amount of \$1,000,000 combined single limit per accident;
  - (d) **Commercial General Liability Insurance** in the amount of \$1,000,000 each occurrence, \$2,000,000 general aggregate, and \$2,000,000 products-completed operations aggregate; and,
  - (e) **Professional Liability Insurance** in the amount of \$1,000,000 each claim and \$2,000,000 annual aggregate.
- 8.2 **Additional Insured.** TRC shall provide additional insured coverage to Client under TRC’s auto and CGL policies coverage using ISO endorsement form CG 20 10 12 19.
- 8.3 **Certificates of Insurance.** Prior to commencing Work, TRC will furnish Client with certificate(s) of insurance evidencing compliance with the insurance requirements herein. Renewal certificates will be provided to Client upon the expiration of any required insurance policies. No policy will be cancelled or not renewed without thirty (30) days’ prior written notice to Client.

#### ARTICLE 9. INDEMNITY

- 9.1 **Definitions.**
- (a) “**TRC Group**” means TRC and its subcontractors of all tiers, and each of their Affiliates, and all their officers, directors, and employees.
  - (b) “**Client Group**” means Client and its Affiliates, and all their officers, directors, and employees.
  - (c) “**Losses**” means any and all damages, costs, or expenses, including, but not limited to, reasonable attorneys’ fees, expert fees, and expenses and costs of litigation.
  - (d) “**Claims**” means all third party claims, lawsuits, demands, or actions.
- 9.2 **TRC’S INDEMNITY OBLIGATIONS.**
- (a) **TRC WILL INDEMNIFY AND HOLD HARMLESS CLIENT GROUP FROM ANY AND ALL LOSSES ARISING OUT OF CLAIMS TO THE EXTENT SUCH CLAIMS ARE CAUSED BY TRC’S NEGLIGENT ACTS, ERRORS, OR OMISSIONS IN THE PERFORMANCE OF ITS PROFESSIONAL SERVICES UNDER THIS AGREEMENT.**
  - (b) **WITH THE EXCEPTION OF CLAIMS ARISING UNDER SECTION 9.2(a), TRC WILL INDEMNIFY AND HOLD HARMLESS CLIENT GROUP FROM LOSSES, AND WILL DEFEND CLIENT GROUP FROM CLAIMS, DUE TO BODILY INJURY, DISEASE, DEATH, OR PROPERTY DAMAGE TO THE EXTENT SUCH BODILY INJURY, DISEASE, DEATH, OR PROPERTY DAMAGE IS CAUSED BY THE NEGLIGENCE OR INTENTIONAL MISCONDUCT OF TRC IN THE PERFORMANCE OF ITS WORK.**
- 9.3 **CLIENT’S INDEMNITY OBLIGATIONS.** **CLIENT WILL INDEMNIFY AND HOLD HARMLESS TRC GROUP FROM LOSSES ARISING OUT OF CLAIMS DUE TO BODILY INJURY, DISEASE, DEATH, OR PROPERTY DAMAGE TO THE EXTENT SUCH BODILY INJURY, DISEASE, DEATH, OR PROPERTY DAMAGE IS CAUSED BY THE NEGLIGENCE OR INTENTIONAL MISCONDUCT OF CLIENT IN THE PERFORMANCE OF THIS AGREEMENT. ADDITIONALLY, NOTWITHSTANDING ANYTHING TO THE CONTRARY HEREIN, IN THE EVENT TRC PERFORMS INTRUSIVE GROUND EXPLORATIONS OR INVESTIGATIONS, INCLUDING BUT NOT LIMITED TO, EXCAVATION, DRILLING, BORING, OR PROBING**

("SUBSURFACE INVESTIGATION") AS PART OF THE WORK, CLIENT WILL INDEMNIFY TRC GROUP FROM AND AGAINST LOSSES RESULTING FROM, OR ARISING OUT OF, CLAIMS FOR DAMAGES TO SUBSURFACE OR UNDERGROUND UTILITIES OR STRUCTURES, INCLUDING BUT NOT LIMITED TO, GAS, TELEPHONE, ELECTRIC, WATER, OR SEWER UTILITIES, WHOSE LOCATIONS WERE NOT DESIGNATED OR IDENTIFIED TO TRC PRIOR TO THE COMMENCEMENT OF ANY SUBSURFACE INVESTIGATION.

9.4 **RISK OF LOSS TO THE WORK.** ADDITIONALLY, NOTWITHSTANDING ANYTHING TO THE CONTRARY CONTAINED HEREIN, IT IS UNDERSTOOD AND AGREED THAT CLIENT BEARS ALL RISK OF LOSS OF OR DAMAGE TO THE WORK AND THE FACILITIES WHICH ARE THE SUBJECT OF THE WORK INCLUDING ALL MATERIALS AND EQUIPMENT TO BE INCORPORATED THEREIN, AND CLIENT HEREBY RELEASES AND SHALL DEFEND, INDEMNIFY, AND HOLD TRC GROUP HARMLESS FROM ANY SUCH LOSS OR DAMAGE, HOWEVER SUCH LOSS OR DAMAGE SHALL OCCUR.

9.5 **CONDITIONS PRECEDENT.** EACH PARTY AGREES THAT AS A CONDITION PRECEDENT TO ITS OBLIGATIONS TO INDEMNIFY AND HOLD HARMLESS, THE INDEMNIFIED PARTY MUST GIVE PROMPT WRITTEN NOTICE TO THE INDEMNIFYING PARTY OF ANY CLAIM COVERED BY ARTICLES 9 OR 10, OR ANY OTHER INDEMNIFICATION CLAUSE IN THIS AGREEMENT. AS AN ADDITIONAL CONDITION PRECEDENT, FOR ANY CLAIM OTHER THAN A CLAIM ARISING OUT OF TRC'S ALLEGED PROFESSIONAL NEGLIGENCE, THE INDEMNIFIED PARTY MUST ALLOW THE INDEMNIFYING PARTY TO REPRESENT THE INTERESTS OF EVERY INDEMNITEE IN DEFENDING AND SETTLING SUCH CLAIM. IN THE EVENT ANY INDEMNITEE FAILS OR REFUSES TO TENDER THE DEFENSE OF ANY SUCH CLAIM TO THE INDEMNIFYING PARTY, SUCH PARTY'S DEFENSE, HOLD HARMLESS, AND INDEMNITY OBLIGATIONS RELATED TO THAT CLAIM WILL BE NULL AND VOID.

9.6 **APPORTIONMENT OF ATTORNEYS' FEES.** NOTWITHSTANDING ANYTHING TO THE CONTRARY HEREIN, AFTER RESOLUTION OF A CLAIM UNDER ARTICLES 9 OR 10, OR ANY OTHER PROVISION HEREIN PROVIDING FOR ONE PARTY TO PROVIDE A DEFENSE, IF THE NEGLIGENCE OR OTHER LEGAL FAULT OF ANY INDEMNITEE IS DETERMINED EITHER BY MUTUAL AGREEMENT OF THE PARTIES, OR BY FINAL ADJUDICATION, TO HAVE BEEN A CONTRIBUTING CAUSE OF THE LOSSES RELATED TO SUCH CLAIM, THEN THE INDEMNIFIED PARTY MUST REIMBURSE THE DEFENDING PARTY FOR THE COSTS, ATTORNEYS' FEES, OTHER LEGAL EXPENSES, AND EXPERT FEES EXPENDED FOR DEFENSE IN THE SAME PROPORTION AS THE INDEMNITEES' PROPORTION OF NEGLIGENCE OR OTHER LEGAL FAULT.

#### ARTICLE 10. HAZARDOUS SUBSTANCES AND POLLUTION

10.1 **Pre-existing Conditions.** Client and TRC acknowledge that, prior to the start of this Agreement, TRC has not generated, handled, stored, treated, transported, disposed of, or in any way taken responsibility for any toxic or hazardous substance, including any contaminated soils, wastes, or substances, as defined by law ("Hazardous Substances") at the Project Site. Any Hazardous Substances originating with or generated by Client, or any pre-existing Hazardous Substances which are in, on, under, or migrating from the Project Site, or any Hazardous Substances introduced to the Project Site by any party other than TRC Group (collectively, "Non-TRC Hazardous Substances"), shall, as between TRC and Client, remain the sole and exclusive property of Client, it being the intention of the Parties that Client be solely responsible for such Non-TRC Hazardous Substances and shall be regarded as the owner and generator of all such Non-TRC Hazardous Substances for the purposes of this Agreement and all Work performed hereunder.

10.2 **Hazardous Substances Encountered During the Work; Disposition of Samples.** If TRC encounters unexpected Hazardous Substances during performance of the Work, and if, in TRC's sole and exclusive judgment, such Hazardous Substances impede the performance of the Work, the Parties shall proceed as provided above in Section 4.4, and TRC shall suspend performance of the Work until such Hazardous Substances are properly contained and/or removed. When containerization and labeling of Hazardous Substances is included in TRC's original scope of Work or is added by Change Order, TRC will appropriately contain and label such materials; and leave the containers on the Project Site for proper, lawful removal, transport, and disposal by Client. All samples of soil, groundwater, waste, rock, or other materials collected from the Project Site will remain the property of Client and will be returned to Client by TRC within thirty (30) days after submission of TRC's report, unless applicable law requires the retention or other disposition of such samples. All costs associated with the disposition or returning of samples will be charged to Client. TRC will not sign any hazardous waste manifests or bills of lading, and all such manifests and generator numbers will be in the name of, and signed by, Client. Nothing contained in this Agreement will be construed or interpreted as requiring TRC, its officers, agents, servants, or employees to assume the status of a generator, storer, treater, transporter, or disposer of hazardous substances, or an arranger for disposal of hazardous substances, or a disposal facility as those terms appear within the Resource Conservation Recovery Act, 42 USCA, Section 6901, et seq. (RCRA), or within any state statute of similar effect governing the treatment, storage, transportation or disposal of waste.

10.3 **TRC INDEMNITY FOR HAZARDOUS SUBSTANCES AND POLLUTION.** TO THE FULLEST EXTENT PERMITTED BY LAW, TRC SHALL ASSUME ALL RESPONSIBILITY FOR, INCLUDING CONTROL AND REMOVAL OF, AND SHALL RELEASE, DEFEND, INDEMNIFY, AND HOLD HARMLESS, ALL MEMBERS OF CLIENT GROUP FROM AND AGAINST ANY LOSSES ARISING OUT OF OR RELATING TO ANY HAZARDOUS SUBSTANCES BROUGHT TO OR RELEASED AT THE PROJECT SITE BY TRC GROUP.

10.4 **CLIENT INDEMNITY FOR HAZARDOUS SUBSTANCES AND POLLUTION.** TO THE FULLEST EXTENT PERMITTED BY LAW, CLIENT SHALL RELEASE, DEFEND, INDEMNIFY, AND HOLD TRC GROUP HARMLESS FROM AND AGAINST ANY LOSSES ARISING OUT OF OR RELATING TO THE PRESENCE AT THE PROJECT SITE OF NON-TRC HAZARDOUS SUBSTANCES. CLIENT SHALL ASSUME ALL RESPONSIBILITY FOR, INCLUDING CONTROL AND REMOVAL OF, AND SHALL RELEASE, DEFEND, PROTECT, INDEMNIFY AND HOLD HARMLESS ALL MEMBERS OF TRC GROUP FROM AND AGAINST ANY LOSSES ARISING OUT OF OR RELATING TO, ANY NON-TRC HAZARDOUS SUBSTANCES DISCOVERED AT, BROUGHT TO, OR RELEASED AT THE PROJECT SITE, OR LEFT ON THE PROJECT SITE AFTER CONTAINERIZATION BY TRC.

#### ARTICLE 11. ALLOCATION OF RISK

11.1 **Client's Separate Contractors.** The Parties expressly acknowledge and agree that unless otherwise expressly provided for in the Proposal, during the performance of the Work TRC shall not (a) supervise, direct or control Client's other contractors or subcontractors at any tier; (b) have authority over or responsibility for the means, methods, techniques or sequences of work performed by such other contractors or subcontractors; (c) be responsible for job site safety or enforcement of federal, state, local or other safety requirements in connection with the work performed by such other contractors or subcontractors; (d) be responsible for

inspecting equipment or tools used by such other contractors or subcontractors; (e) be liable for any failure of such other contractors or subcontractors to comply with applicable laws, rules, regulations, ordinances, codes, permit stipulations, or orders; or (f) be liable for the acts or omissions of such other contractors or subcontractors including their failure to perform in accordance with their contractual responsibilities.

- 11.2 **Mutual Waiver of Consequential Damages.** Notwithstanding anything to the contrary in this Agreement, TRC and Client waive any and all claims against each other and each other's Affiliates, and under no circumstances shall either Party or its Affiliates be liable to the other, for incidental, consequential, special, multiple, and punitive damages arising out of or relating to this Agreement, regardless of whether such damages were foreseeable and whether or not the culpable Party was advised of the possibility of such damages, and regardless of whether a Party's claim against the other Party is based in contract (including contract termination), indemnity, warranty, tort (including negligence), strict liability or otherwise. This mutual waiver includes, but is not limited to, rental expenses, loss of use, loss of production, loss of income, loss of profit (except profit arising directly from the Work), loss of financing, loss of business, and loss of reputation.
- 11.3 **Limitation of Liability.** To the fullest extent permitted by law, the total liability in the aggregate of TRC and its Affiliates, and each of their employees, officers, directors, subcontractors, or suppliers to Client and anyone claiming by, through or under Client, on all claims of any kind arising out of or in any way related to TRC's Work, from any cause or causes whatsoever, including, but not limited to, negligence, errors, omissions, strict liability, indemnity, or breach of contract, will not exceed the compensation received by TRC under this Agreement. All such liability will terminate upon the expiration of the Correction Period specified in Section 6.3. THIS SECTION SETS FORTH TRC'S SOLE LIABILITY AND ENTIRE OBLIGATION AND CLIENT'S EXCLUSIVE REMEDY FOR ANY ACTION BROUGHT AGAINST TRC IN RELATION TO THIS AGREEMENT.

#### ARTICLE 12. DELIVERABLES

- 12.1 **Ownership of Deliverables.** All Deliverables shall become the sole and entire property of Client after TRC receives payment for such Deliverables. As used herein, the term "Deliverable" means completed instruments of professional services prepared solely and exclusively for Client pursuant to the requirements of this Agreement, such as stamped reports, drawings, designs, completed calculations, recommendations, and evaluations in association with the Project, which are provided in PDF format or via email or other format required by the Agreement. The term "Deliverable" does not apply to TRC's internal notes or documentation, field data, laboratory test data, calculations, estimates, or any work-in-progress except to the extent the Agreement requires submission of preliminary or progress designs. Notwithstanding anything to the contrary herein, to the extent any Deliverables include proprietary information that is not prepared solely and exclusively for Client, such proprietary information shall remain the exclusive property of TRC, but Client will have unrestricted and non-exclusive rights and license to use such information. TRC's proprietary information, includes, but is not limited to, its seal, stamp, or certification; know-how; methodologies; techniques; processes; tools, pre-existing documents; trade secrets, patents, patents pending, standard details, templates, figures, or specifications; computer programs; software; inventions; intellectual property; or systems (a) utilized or developed prior to the effective date of the Agreement; (b) developed for work being provided to any person or entity other than Client, and/or (c) owned or duly licensed by TRC and used in the performance of the Work and/or embedded in the Deliverables; (d) improved, modified, developed, or created by TRC in the course of or as a consequence of performing the Work. Furthermore, Client understands and agrees that TRC is a developer of computer software and that TRC may use its own proprietary software, as well as others properly licensed to TRC, in the performance of the Work, and may develop other proprietary software during the course of performing the Work, which may include preliminary database formats and spreadsheets as well as programming procedures and code. Client understands and agrees that all such programs, efforts, and materials are and will be the exclusive property of TRC (and/or third parties).
- 12.2 **Use of Deliverables.** Any Deliverable will be prepared solely for use of Client for this Project. The Deliverables are not intended or represented to be suitable to be reused by Client, or used or relied upon by others outside of Client or on extensions of the Project or on any other project. In the event Client, its employees, permitted assigns, successors, consultants, or contractors subsequently reproduces or otherwise uses the Deliverables or creates a derivative work based upon the Deliverables, unless prohibited by law, Client must remove or completely obliterate the original professional seals, trademarks, logos, and other indications on said Deliverables of the identity of TRC, its employees, and sub-consultants. TRC will be entitled to equitable compensation in connection with documenting any consent for Client or third parties to rely on the Deliverables for any purpose other than the purpose for which TRC prepared them.
- 12.3 **Unauthorized Use of Deliverables.** Client is prohibited from providing examples of TRC's Work to any individual or entity known by, or that reasonably should be known by, Client to be a competitor of TRC for the purpose of reducing or eliminating the Work associated with this Agreement. Furthermore, Client is prohibited from providing any statistical sampling information on assessment issues, including but not limited to statistical sampling information on production rates, remedy rates, numbers of pole change outs, types of violations, etc., that is provided to Client by TRC, all of which must be treated by Client as Confidential Information. In the event any Deliverables are utilized or disclosed by Client in any manner outside the scope of, or prohibited by, this Agreement, TRC reserves the right to notify directly any third party of the limitations of its unauthorized use of the Deliverables. Client expressly acknowledges that this reservation by TRC is necessary to protect and preserve TRC's professional reputation with respect to its work product.

#### ARTICLE 13. SAFETY

- 13.1 **Client's Safety Requirements.** Client must inform TRC of any written safety procedures and regulations applicable to the Project Site known to Client, as well as any special safety concerns or dangerous conditions at the Project Site. TRC and its employees will adhere to the written safety procedures and regulations provided by Client.
- 13.2 **Project Site Safety.** TRC commits to providing a safe and healthy work environment for its personnel and will require the same of its subcontractors. TRC shall be responsible for the health and safety of its employees and be responsible for its activities, and shall at all times conduct its operations under this Agreement in a manner to avoid risk of endangerment to the health and safety of persons and property. Unless expressly included in the scope of Work, TRC will not have any responsibility for overall job safety for the Project or at the Project Site. If TRC determines that its field personnel are unable to access required locations or perform required

Work in conformance with applicable safety standards, TRC may suspend performance until its personnel can safely perform their work. TRC will promptly provide Client with written notice of the location and nature of the unsafe conditions. If Client fails to provide safe access within a reasonable time, TRC may terminate or suspend its performance in accordance with Article 14.

- 13.3 **Reporting of Incidents.** In the event TRC is involved in any loss, injury, or damage on Client's premises, or if such injury, loss or damage involves property, equipment, or personnel of Client, or if such accident involves any third party in any manner whatsoever while TRC is performing any duties within the scope of this Agreement, TRC will promptly report such injury, loss, or damage to the attention of Client's designated representative. If the matter involves loss of life, serious injury, or substantial property loss or damage, this report will be made by telephone call, followed immediately by a report in writing sent via email. If the matter is of a less serious nature, notification may be made by email or by letter posted in regular United States mail. All injuries, loss or damage must be reported. The reporting of any such matter will not imply any admission of liability on the part of TRC.

#### ARTICLE 14. TERMINATION AND SUSPENSION

- 14.1 **Termination for Default.** In the event of a material breach of this Agreement by either Party, the nonbreaching Party may give written notice to the breaching Party of the nature of the default and demand for cure. If the breaching Party fails to cure or materially commence to cure within ten (10) days from receipt of the default notice, the non-breaching Party may provide a written notice of termination of the Agreement to the breaching Party.
- 14.2 **Termination or Suspension for Convenience.** Either Party may terminate or suspend this Agreement, in whole or in part, by providing written notice to the other Party at least thirty (30) days prior to the effective date of termination.
- 14.3 **Termination for Insolvency.** Either Party has the right to immediately terminate the Agreement, by providing written notice to the other Party, in the event that (a) the other Party becomes insolvent, enters into receivership, is the subject of a voluntary or involuntary bankruptcy proceeding, or makes an assignment for the benefit of creditors; or (b) a substantial part of the other Party's property becomes subject to any levy, seizure, assignment or sale for or by any creditor or government agency.
- 14.4 **Payments Due Post-Termination.** TRC will be entitled to receive payment for all Work performed prior to the effective date of the suspension or termination, plus all reasonable costs associated with the suspension or termination, including, but not limited to, demobilization costs, re-stocking fees, cancellation fees, and costs incurred with respect to non-cancellable commitments. If the suspension or termination is the result of TRC's breach, prior to paying TRC Client will be entitled to offset its reasonable, direct, documented losses to the extent caused by TRC's breach. If the suspension or termination is the result of Client's breach, in addition to all other compensation to which TRC is entitled, TRC will be entitled to receive payment for its reasonable, direct, documented losses to the extent caused by Client's breach.

#### ARTICLE 15. DISPUTE RESOLUTION

- 15.1 **Negotiation by Executives.** The Parties will attempt in good faith to resolve any dispute, controversy, or claim arising out of or relating to the Project or the Agreement or the breach thereof ("Dispute") promptly by negotiation. When either Party determines it has exhausted its efforts to resolve a Dispute at the Project level, that Party may provide written notice to the other Party of the Dispute. Within fifteen (15) days after the date of such notice, executives of both Parties who have authority to agree to a settlement of the Dispute and who are at a higher level of management than the persons with direct responsibility for administration of this Agreement will meet at a mutually acceptable time and place (or, otherwise, at the Project Site), and thereafter as often as they reasonably deem necessary, to attempt to resolve the Dispute. All negotiations pursuant to this subsection are confidential and will be treated as compromise and settlement negotiations for purposes of applicable rules of evidence. If the Parties do not resolve the Dispute within sixty (60) days of a Party notifying the other of the Dispute, unless extended by mutual agreement, either Party may commence litigation.
- 15.2 **Governing Law, Jurisdiction, Venue.** Unless otherwise required by law, this Agreement, and any act or transactions to which it will apply, or which are contemplated hereby or hereunder, will be governed by, and construed and interpreted in accordance with, the laws of the State of Connecticut without regard to choice of law or conflicts of law principles. This choice of law expressly includes the applicable statutes of limitation. Venue for all actions under the Agreement will be in Hartford, Connecticut.
- 15.3 **Prevailing Party.** In the event of any binding dispute resolution proceeding, declaratory or otherwise, brought by a Party arising out of or relating to this Agreement, including but not limited to any breach or default of the Agreement, the prevailing Party will be entitled to recover from the other Party any and all expenses of litigation, court costs, expert and consultant fees, employee time and expenses, and reasonable attorneys' and other legal fees associated with such proceedings (collectively, "Litigation Expenses"), accruing as of commencement of the proceeding and including execution and collection of any award or judgment. Notwithstanding the foregoing, if a written offer of compromise is made by either Party that is not accepted by the other Party within thirty (30) days after receipt and the Party not accepting such offer fails to obtain a more favorable judgment or award, the non-accepting Party will not be entitled to recover its Litigation Expenses (even if it is the prevailing Party) and will be obligated to pay the Litigation Expenses of the offering Party.

#### ARTICLE 16. MISCELLANEOUS

- 16.1 **Independent Contractor and Waiver of Benefits.** TRC is an independent contractor and will not be regarded as an employee or agent of Client. TRC agrees that it will not receive, and is not eligible to participate in, any employee benefit plan, insurance program, disability plan, medical benefits plan, or any other fringe benefit program sponsored and maintained by Client for its regular active employees, and TRC hereby waives any rights or claims related thereto.
- 16.2 **Compliance with Laws.** TRC will observe all applicable provisions of the federal, state, and local laws and regulations, including those relating to equal opportunity employment.
- 16.3 **Severability.** If any term, covenant, condition, or provision of this Agreement is found by a court of competent jurisdiction to be invalid, void, or unenforceable, the remainder of this Agreement will remain in full force and effect, and will in no way be affected, impaired, or invalidated thereby.
- 16.4 **Waiver.** No waiver of any provision of this Agreement, or consent to any departure therefrom, shall be effective unless in writing and signed by the waiving Party, and then such waiver or consent shall be effective only in the specific instance and for the specific purpose for which given. No failure or delay on the part of any Party in exercising any right, power or remedy hereunder shall operate

as a waiver thereof, nor shall any single or partial exercise of any such right, power or remedy preclude any other or further exercise thereof or the exercise of any other right, power or remedy hereunder.

- 16.5 **Assignment.** Neither Party will assign or transfer this Agreement without the prior written consent of the other Party. Moreover, as a condition of any such written consent, such assignment will be subject to the terms and conditions herein and no greater rights or remedies will be available to the assignee. In the event of an assignment by Client, Client will provide TRC with the information necessary for notices and invoicing (as applicable) prior to the effective date of the assignment. Client hereby agrees that TRC may subcontract and/or assign some or all of the Work to one or more of its Affiliates to the extent necessary to provide sufficient staffing and/or to comply with applicable insurance or professional licensing requirements.
- 16.6 **Captions.** The captions of the articles and sections in this Agreement are intended solely for the convenience of reference and will not define, limit, or affect in any way the provisions, terms, and conditions hereof or their interpretation.
- 16.7 **Integration.** This Agreement represents the entire understanding and agreement between the Parties and supersedes any and all prior or contemporaneous agreements, whether written or oral, and may be amended or modified only by a written amendment signed by both Parties.
- 16.8 **Amendments.** This Agreement may be modified only by a Change Order or an amendment executed in writing by a duly authorized representative for each Party.
- 16.9 **No Third Party Beneficiaries.** Except as otherwise specifically provided for herein, this Agreement shall not be construed to confer any benefit on any third party not a Party to this Agreement, nor shall it provide any rights to such third party to enforce its provisions. Notwithstanding the foregoing, all liability-limiting provisions of this Agreement shall extend and inure to the benefit of all members of TRC.
- 16.10 **Signatures.** The Proposal may be executed electronically and/or in counterparts, each of which will be deemed an original, and all of which together will be deemed to be one and the same instrument. A copy of the Proposal delivered of electronic transmission will be deemed to have the same legal effect as delivery of a manually signed original. Each person executing the Proposal warrants that he/she is authorized to do so on behalf of the Party for whom he/she signs the Proposal.
- 16.11 **Notices.** Any notice permitted to be given by email shall be sent to the below representative. Any other notice required to be given pursuant to this Agreement must be in writing and sent by overnight delivery via USPS or a nationally recognized courier and delivered to the address set forth in the first paragraph above to the attention of the representative below:  
If to TRC, send to the attention of: the person signing the Proposal  
If to Client, send to the attention of: the recipient of the Proposal  
Any notice so given will be deemed effective upon receipt. Either Party may change its representative or address effective ten (10) days after written notice thereof to the other Party.
- 16.12 **Remittance Information.** TRC remittance information for making payments is as follows:

**U.S. Postal Service:**

TRC Lockbox  
PO Box 536282  
Pittsburgh PA 15253-5904

**Overnight Packages:**

TRC Lockbox  
Attn: 536282  
307 23<sup>rd</sup> Street Extension, Suite 950  
Pittsburgh, PA 15215  
877-550-5933

**Wire Instructions (PREFERRED METHOD OF PAYMENT)**

<b>Beneficiary Account Name:</b>	TRC Companies, Inc. – Concentration
<b>Beneficiary Account Number:</b>	2232037090
<b>Bank Codes:</b>	
<b>ABA Number:</b>	011500120 (Wires only)
<b>Routing Number:</b>	211170114 (ACH only)
<b>Swift Code:</b>	CTZIUS33
<b>Bank Name:</b>	Citizens Bank

<b>Remittance Detail Email:</b>	<a href="mailto:ARemitdetail@trccompanies.com">ARemitdetail@trccompanies.com</a>
<b>TRC Contact:</b>	Dawn Dostie
<b>Contact Phone Number:</b>	207-660-7222



March 28, 2024

Mr. John Troy  
Assistant Superintendent & General Counsel  
Minooka Community High School District #111  
301 S Wabena Ave  
Minooka, Illinois 60447

*Via Email at: [jtroy@mchs.net](mailto:jtroy@mchs.net)*

**RE: Proposal for Asbestos Abatement Oversight and Clearance Air Sampling  
GYMNASIUM  
Minooka High School  
Minooka, IL**

Dear Mr. Troy,

TRC Environmental Corporation (TRC) is pleased to present this proposal to Minooka Community High School District #111 (hereinafter referred to as the "Client") to perform asbestos abatement oversight and clearance air sampling services at the above-referenced property. Please find below our project understanding, anticipated project scope, fees, proposed project schedule, and business terms.

#### **PROJECT UNDERSTANDING**

TRC understands that the client has a gymnasium replacement project upcoming at the school. The replacement project involves the removal of the gym plank flooring, support girts and underlayment and mastic underneath. The scope of this project is removing the asbestos-containing back mastic which is located beneath the underlayment. TRC has been requested to provide environmental consulting services including; asbestos abatement oversight, air monitoring services and final clearance sampling of abatement activities.

#### **SCOPE OF WORK**

TRC proposes to complete the following scope of work, including delivery of final report, as described herein. Upon receipt of notice to proceed, TRC will coordinate with Client regarding the project schedule and deliverables.

##### **Task 1: Abatement Contractor Oversight**

TRC will perform project management and asbestos abatement oversight activities to help ensure satisfactory completion of necessary abatement activities in accordance with the specification and Client requirements as well as applicable federal, state and local regulations. TRC's scope of work will include the following:

- Coordinate with the Client and/or Client designated representatives, construction and abatement contractor in scheduling and coordinating abatement activities via phone/email support.
- Provide on-site oversight during abatement contractor activities to help ensure that the abatement activities are being conducted in accordance with applicable regulations and provide daily email updates to the project team. This will include collecting ambient air samples at containment entrances and waste load out areas.



- Work with the project management team/Client to implement a punch-list as needed.
- TRC will have a representative on-site during the abatement activities.

### **Task 2: Final Visual Inspections and Clearance Sampling**

TRC will provide an asbestos air sampling professional for maintaining communication with the project manager and the Client and performing final visual inspections and a visual clearance. Consultant proposed services involve daily air monitoring, work area inspections, final inspections and a visual clearance. Consultant will collect daily air samples. The daily air sample analysis and will be analyzed by Phase Contrast Microscopy (PCM). The clearance air sample analysis will be analyzed by Transmission Electron Microscopy (TEM). The project is estimated for a duration of approximately 15 shifts.

The project will be monitored by the consultant's project managers, who are licensed by the IDPH as asbestos project managers and air sampling professionals. The consultant's staff will be managed by the consultant's project manager, with oversight and consultation by a TRC Senior Project Manager.

### **Task 3: Project Management and Consulting Services**

TRC will provide professional consulting services as needed to assist and support the Client with respect to this type of project.

### **Task 4: Close-Out Reporting**

TRC will prepare a summary close-out report to include: air sampling results; a description of abatement activities; abatement contractor submittals, waste manifests, disposal receipts, reclamation receipts; and recommendations (if any). One electronic final written close-out report will be provided to Client within 60 days after completion of final abatement activity.

### **FEES**

The total cost estimate for the project is **\$23,857.00**, unless additional tasks or mobilizations are required, and will be invoiced as lump sum and based on the fee breakdown below. TRC will inform Client of the anticipated costs of completing any additional work prior to completion of the additional work.

#### Labor & Expenses

##### Labor:

Principal - \$211.00/hr

Sr PM – \$140.00/hr

Illinois Certified Asbestos Project Manager / Inspector - \$133.00/hr

Clerical - \$90.00/hr

##### Expenses (Sample Analysis and Travel):

TEM analysis standard (24-hour) – \$90.00/sample

Mileage - \$0.66/mile

TRC appreciates the opportunity to be of service to Minooka Community High School District #111 on this project. If you have any questions regarding this proposal, please contact the undersigned at (847) 721-7582.

Respectfully submitted,



Mitchell Pendergrass  
Central Region Practice Leader

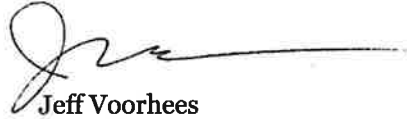

Jeff Voorhees  
Sr. Project Manager

Agreed to and Authorized by:

  
\_\_\_\_\_

Client

  
\_\_\_\_\_

Date

**Fred J Miller**  
 8765 Washington Church Rd  
 Miamisburg, OH 45342  
 800-444-3524  
 amber.waugh@fjminc.com  
 www.fjminc.com



# INVOICE

**BILL TO**

Minooka High School  
 Band Department  
 301 S. Wabena Ave  
 Minooka, IL 60447

**SHIP TO**

Minooka High School  
 Kyle Adelmann / Band  
 301 S. Wabena Ave  
 Minooka, IL 60447

**INVOICE #** #13275

**DATE** 03/19/2024

**DUE DATE** 04/18/2024

**TERMS** Net 30

**ORDER NUMBER**

FJM13314

DATE	ACTIVITY	DESCRIPTION	QTY	RATE	AMOUNT
	<b>Cesario Uniform</b>	219 Band and 6 DM full uniforms with Apollos and plumes and shipping	1	122,400.00	122,400.00

50% Deposit due upfront for uniforms to be placed on production schedule unless a purchase order is used.  
 50% of this order = \$61,200

SUBTOTAL	122,400.00
TAX	0.00
TOTAL	122,400.00
<b>BALANCE DUE</b>	<b>\$122,400.00</b>