



**MINOOKA COMMUNITY HIGH SCHOOL DISTRICT #111
REGULAR BOARD MEETING
TUESDAY, MAY 4, 2021, 6:00 PM**

The Regular Board Meeting will be held at the
Academic Resource Center
301 South Wabena Avenue
Minooka, Illinois 60447

Attendance - Limited seating will be available on a first-come, first-serve basis. Therefore, members of the public are welcome to attend this meeting in person. The meeting can also be viewed via YouTube. Click here.

For planning purposes, MCHS #111 would appreciate advance notice of in-person attendance. Please contact the district office at 815/521-4311 or cward@mchs.net by 3:00 p.m. on May 4, to RSVP, or for additional information regarding attendance or public comments.

Public Comments - Members of the public that wish to make a public comment can do so in person or by email. To submit by email, the subject line must read "For Public Comment". Send to Colleen Ward (cward@mchs.net) with public comment by 3:00 PM on May 4. Public comments submitted via email will be included with the next regular board meeting packet.

AGENDA

1. **Call to Order**
2. **Roll Call**
3. **Pledge of Allegiance**
4. **Consent Agenda - Approval of Open Session Minutes** 5
5. **Declaration of Winners**
 - A. Declaration of Winners in the Election of Members to the Board of Education of the Minooka Community High School District #111
 - Deirdra Crye - 2-year unexpired term
 - James Grzetich - 4-year full term
 - Matt Shepard - 4-year full term
 - Michael Brozovich - 4-year full term
 - B. Declare Board of Education Vacancy for Unincorporated Member - Board member Mike Brozovich is from the unincorporated area. A board vacancy is declared, as this does not fulfill the board's requirement to have at least two individuals from that area serving on the board (no action required).
 - C. Administration of Oath of Office to New Board Members 21
6. **Recognition of Retiring Board Members**
 - Ms. Cherie Barnes (2017-2021)
 - Mrs. Wendi Arlis (2014-2021 and Secretary 2015-2021)

- Mrs. Patti Ruettinger (Secretary 2005-2009 and Vice-President 2013-2021)

7. Adjourn Sine Die

B R E A K

REORGANIZATION AGENDA

8. Call to Order	
9. Reorganization	22
A. Appointment of Pro Tem	
• President	
• Secretary	
B. Election of Officers	
• President	
• Vice-President	
• Secretary	
10. Reorganization Action Items	
A. Name the School District Depositories as presented	31
B. Appointment of the School District Treasurer – John Troy	
C. Appointment of Delegate to the IASB Convention	
D. Appointment of GAVC Representative	
E. Appointment of GCSEC Representative	
F. Appointment of Attorneys	
• Scariano & Himes	
• Hauser Izzo, LLC	
• Franczek P.C.	
G. Set Dates, Times, and Locations of Regular Board Meetings	32
H. Committee Structure	35
I. Adopt Code of Conduct	37
11. Communications / Recognition	
12. Public Comments - (Per Board Policy 2:230, comments shall be limited to 5 minutes.)	
13. Administrative Reports	
A. Superintendent	38

B. Principal	42
C. Assistant Superintendent of Business	43
D. Director of Curriculum & Instruction	44
E. Community Relations Director	45
14. Consent Agenda	
A. Approval of Financial Reports	
1. Payment of Bills/Total	50
2. Employee Payroll	221
3. Imprest Fund Report/Total	222
4. Activity Fund Report	226
5. Treasurer's Report (Cash/YTD - Exp/Rev)	232
B. IHSA Membership Renewal	315
15. Committee Reports	
• Buildings & Grounds (_____, Heap, Hrechko) - Wednesday, April 14, 2021, 5:30 p.m.	
• Co-Curricular (_____, _____, Crye) - None	
• Curricular (Heap, _____, Crye) - None	
• Finance (Crye, Heap, Brozovich) - Wednesday, April 14, 2021, 5:30 p.m.	
• Personnel (Brozovich, _____, Hrechko) - Wednesday, April 14, 2021, 5:30 p.m.	
• Policy (Hrechko, _____, Brozovich) - Wednesday, April 14, 2021, 5:30 p.m.	
• Special Education (_____, _____, Crye) - None	
• Technology (_____, Crye, _____) - None	
• Transportation (_____, Hrechko, _____) - None	
• GAVC (_____) - None	
16. Discussion Items	
A. RTL Update	316
B. Educational Foundation Update	319
C. Strategic Plan Update	320
D. Policy Review	321
E. Transportation Drainage Project	322
17. Action Items - Consideration and Possible Approval to Award the Transportation Draining Project Bid to the Low Bidder, Winner Excavating, in the amount of \$88,901 as Presented	
18. Executive Session - To adjourn the meeting to executive session for discussion on matters related to minutes; the appointment, compensation, discipline, dismissal, employment and performance of specific employees of the District; the purchase or lease	

of real property for the use of the public body; litigation; and collective bargaining.

19. Action Items Following Executive Session

- A. Consideration and Possible Approval of Closed Session Minutes
- B. Consideration and Possible Acceptance of Resignation(s)
- C. Consideration and Possible Approval of Paid/Unpaid Leave Request(s)
- D. Consideration and Possible Approval of Employment
- E. Consideration and Possible Approval of Volunteers
- F. Consideration and Possible Approval of Employment Termination of Non-certified Staff Member as Presented
- G. Consideration and Possible Approval of MOU as Presented

20. Announcements and Communications

- A. Other - Upcoming Events (Graduation, BOE Pictures, IASB Training)

21. Adjourn

**MINOOKA COMMUNITY HIGH SCHOOL
DISTRICT #111
COMMITTEE OF THE WHOLE MEETING
WEDNESDAY, MARCH 10, 2021**

CALL TO ORDER

The committee meeting was called to order at 5:30 p.m. by Vice-President Patti Ruettiger. The meeting was held at Minooka Community High School-Central Campus in the ARC (Academic Resource Center). . Members of the public were welcome to attend in person (with social distancing measures in place). Public comments were accepted in person or via email. A physical quorum was present with the following board members answering roll call:

	<u>YES</u>	<u>NO</u>
• Mike Brozovich	X (arrived at 5:40 pm)	
• Laura Hrechko	X (arrived at 5:39 pm)	
• Patti Ruettiger	X	
• Dee Crye	X (arrived at 5:35 pm)	
• Cherie Barnes	X (arrived at 5:32 pm)	
• Wendi Arlis	X	
• Dustin Heap	X	

Additionally present were:

- Bryan Zwemke X
- John Troy X
- Kenny Lee X
- Colleen Ward X

Additionally, at the meeting were Brent Edwards, Joe Pacetti, Matt Wikoff, and Jamie Soliman.

PUBLIC COMMENTS

There were no comments from the audience.

DISCUSSION

EQUITY AND DIVERSITY COMMITTEE UPDATE

Erika Thomas-Walker addressed the board remotely regarding equity and diversity.

SPECIAL COMMITTEE/TASK FORCE UPDATE

Dr. Lee provided an update on the special committee/task force regarding the cultural assessment. He noted that two meetings have been held thus far and outside guests have come in to speak

RETURN TO LEARN

Dr. Lee provided an update on the return to learn status and options were discussed for returning to 5 days a week, dismissal time and whether or not to include lunches.

POLICY

Parent/Student Handbook:

Assistant Principal Matt Wikoff addressed the board regarding recommendations for changes to the Parent/Student Handbook. Discussion took place and suggestions were made for revisions to the recommendations. It is anticipated that the handbook will be brought forward and at the board meeting for a first reading and subsequent approval at the April meeting.

AP Manual Project:

Dr. Lee reported that the AP Manual Project (Administrative Procedures) is underway.

BUILDINGS & GROUNDS - ESG

ESG Account Executive Kimberly Brisley addressed the board to give an update on the status of current projects as well as to provide information on a 5-year master plan. She also addressed CoVid-19 and indoor air quality improvements.

FINANCE COMMITTEE

Financial Reports:

Financial reports were provided in the board packet.

1:1 Plan Implementation/Financing (Chromebooks Purchase):

Information was provided in the board packets regarding chromebooks purchasing. It is anticipated to be recommended for approval at the board meeting.

Student Fees:

Information was provided in the board packets regarding student fees based on the cost of chromebooks. As the district continues with the 1:1 laptop program, the cost of the chromebooks will impact student fees. . It is anticipated to be recommended for approval at the board meeting.

Printers Refresh:

Information was provided in the board packets regarding the printers and a new lease. It is anticipated to be recommended for approval at the board meeting.

Request for Proposals - Food Service:

Information was provided regarding renewing the contract with Quest Management Food Services for the 2021-2022 school year. It is anticipated to be recommended for approval at the board meeting.

Request for Proposals - Buses:

Information was provided regarding purchasing (replacing) 10 buses. It is anticipated to be recommended for approval at the board meeting.

Request for Proposals – Audit Bid:

John Troy reported that it is time to seek audit bids per customary practice.

OTHER

Discussion took place regarding the date of the April board meeting and the timeline regarding the election and canvassing of the results. Consensus was reached to move the April 21 board meeting to Tuesday, May 4, at 6:00 p.m.

EXECUTIVE SESSION

MOTION: by Arlis, seconded by Heap, to adjourn the meeting to executive session for the purpose of discussing personnel, real property, collective bargaining, and litigation. Voting Aye: Arlis, Hrechko, Crye, Ruettiger, Heap, Barnes, and Brozovich. Motion carried. Time: 7:44 p.m.

RETURN TO OPEN SESSION

MOTION: by Hrechko, seconded by Heap, to return to open session. Voting Aye: Arlis, Hrechko, Crye, Ruettiger, Heap, Barnes, and Brozovich. Motion carried. Time: 8:52 p.m.

UPCOMING EVENTS

Discussion took place regarding upcoming events. Consensus was reached that final exams would not be held for second semester. Additionally, prom and graduation options were discussed.

ADJOURNMENT

MOTION: by Heap, seconded by Barnes, to adjourn the meeting. Voting Aye: Arlis, Hrechko, Crye, Ruettiger, Heap, Barnes, and Brozovich. Motion carried. Time: 9:03 p.m.

**MINOOKA COMMUNITY HIGH SCHOOL
DISTRICT #111
REGULAR MEETING
WEDNESDAY, MARCH 17, 2021**

CALL TO ORDER

The regular meeting was called to order at 6:00 p.m. by Vice-President Patti Ruettiger. The meeting was held at Minooka Community High School-Central Campus in the ARC (Academic Resource Center). Members of the public were welcome to attend in person (with social distancing measures in place) or to view via YouTube. Public comments were accepted in person or via phone or email. A physical quorum was present with the following board members answering roll call:

	YES	NO
• Mike Brozovich		X
• Laura Hrechko	X	
• Patti Ruettiger	X	
• Dee Crye	X	
• Cherie Barnes	X (arrived at 6:39 pm)	
• Wendi Arlis	X	
• Dustin Heap	X	

Additionally present were:

- | | |
|-----------------|---|
| • Brent Edwards | X |
| • Bryan Zwemke | X |
| • John Troy | X |
| • Kenny Lee | X |
| • Colleen Ward | X |

Additionally at the meeting were Janel Grzetch, Joe Pacetti, Jamie Soliman, and Kevin Murphy.

The Pledge of Allegiance was recited.

Due to the pandemic, the agenda for the meeting was reduced.

COMMUNICATIONS/RECOGNITION

Board members were pleased to recognize the following:

- Girls Bowling Coach of the Year by the National Federation of State High School Associations - Frank Yudzentis
- 3rd Place Finish at IHSA Dance State Finals - MCHS Arrowettes

PUBLIC COMMENTS

- MEA President Dave Barney addressed the board to speak in support of a teacher whose contract is not being renewed.
- Student Evelyn Maruszak spoke in support of maintaining the current learning schedule for MCHS.
- Teacher Adrianna Walker spoke in support of maintaining the current learning schedule for MCHS.
- Student Jacob Pursell thanked the board of education for moving their regular meetings out of the PAC and into the ARC to allow the spring musical to set up and practice.

ADMINISTRATIVE REPORTS

Administrative reports were provided to the board members in the packets.

CONSENT AGENDA

MOTION: by Heap, seconded by Hrechko, to approve the consent agenda as presented:

- A. Open Session Minutes
 - 1. February 10, 2021 – Committee Meeting
 - 2. February 17, 2021 – Regular Meeting
- B. Financial Reports
 - 1. Payment of Bills/Total
 - 2. Employee Payroll
 - 3. Imprest Fund Report/Total
 - 4. Activity Fund Report
 - 5. Treasurer's Report (Cash/YTD – Exp/Rev)
- C. One-time CoVid Stipend

Voting Aye: Arlis, Ruettiger, Heap, Hrechko, and Crye. Motion carried. Time: 6:33 p.m.

DISCUSSION ITEMS

Return to Learn Update:

Discussion took place regarding options for the Return to Learn Plan. Suggestions regarded the number of days per week, the purpose of Wednesdays, and whether or not to include period and space for lunches.

Educational Foundation Update:

Dr. Lee reported that the next scheduled meeting is April 20, and the Foundation continues to encourage staff to request grants.

Strategic Plan Update:

Dr. Lee reported that Goal Leaders held a meeting on March 4. He added that they will meet one more time to review the school year and then report progress, as well as preview next school year, with the Board of Education. That will be tentatively scheduled for the June meeting.

Policy Review:

A brief synopsis was provided in the board packet reviewing selected MCHS #111 Board of Education Policies as part of an ongoing review of the BOE policy manual.

Parent/Student Handbook:

The parent/student handbook was presented as a first reading with anticipation to be presented for second reading and adoption at the April board meeting.

1:1 Plan Implementation/Financing (Chromebooks Purchase):

Information was provided in the board packets regarding the recommendation for purchase of chromebooks. The recommendation is for 770 chromebooks from Trafera with a four-year lease with American Capital.

Student Fees:

Information was provided in the board packets regarding the recommendation for student fees for the 2021/2022 school year. The recommendation would be to keep the fees the same as the prior year for sophomores, juniors, and seniors. The fee for freshmen students would be \$120.

Printers Refresh:

Information was provided in the board packets regarding the recommendation for a new printers lease. The recommendation would be for a contract with Proven in the amount of \$407,977 and service in the amount of \$3,950/mo and approve entering into a 5-year purchase lease agreement with American Capital in the annual lease amount of \$85,264.80.

Request for Proposals – Food Service:

Information was provided in the board packets regarding the recommendation to renew the food service contract with Quest Management Services. The contract would maintain the terms and conditions as the previous year.

Request for Proposals – Buses:

Information was provided in the board packets regarding the recommendation to accept the bid for the purchase of eleven, 71-passenger school buses from Central States for \$89,040 per bus and a Guaranteed Buy Back at the end of 5 years for \$30,000 and also to approve entering into a 5-year purchase lease agreement with American Capital in the annual lease amount of \$12,868 per bus.

ACTION ITEMS**Return to Learn Instructional Model:**

MOTION: by Hrechko, seconded by Crye, to approve the adjustment to the 2020/2021 Instructional Model regarding the Return to Learn Plan as presented, in-person learning 5 days a week with the same daily schedule/dismissal time for students (approximately 8am-1pm). Voting Aye: Heap, Hrechko, Arlis, Ruettiger, Crye, and Barnes. Motion carried. Time: 7:01 p.m.

MOTION: by Arlis, seconded by Hrechko, to approve an amendment to the motion to note that the adjustment to the Return to Learn Instructional Model of five days a week begins after spring break. Voting Aye: Heap, Hrechko, Arlis, Ruettiger, Crye, and Barnes. Motion carried. Time: 7:52 p.m. Note: the amended motion was approved later in the meeting following executive session, however, was also included here in the minutes for continuity of the agenda item.

Chromebook Purchase:

MOTION: by Arlis, seconded by Barnes, to approve the Purchase of 770 Chromebooks from Trafera in the amount of \$237,930 and enter into a 4-year lease agreement with American Capital in the amount of \$67,044.95 per year. Voting Aye: Heap, Hrechko, Arlis, Ruettiger, Crye, and Barnes. Motion carried. Time: 7:02 p.m.

Student Fees:

MOTION: by Barnes, seconded by Arlis, to approve setting the student fees for the 2021/2022 school year as presented, with fees remaining the same as the prior year for sophomores, juniors, and seniors. The fee for freshmen students would be \$120. Voting Aye: Heap, Hrechko, Arlis, Ruettiger, Crye, and Barnes. Motion carried. Time: 7:02 p.m.

Printer Refresh:

MOTION: by Arlis, seconded by Heap, to approve a contract for the printer refresh with Proven in the amount of \$407,977 and service in the Amount of \$3,950/mo, and to approve entering into a 5-year lease purchase agreement with American Capital in the annual lease amount of \$85,624.80. Voting Aye: Heap, Hrechko, Arlis, Ruettiger, Crye, and Barnes. Motion carried. Time: 7:03 p.m.

Food Service:

MOTION: by Crye, seconded by Hrechko, to approve renewal of the contract with Quest Food Management Services for the 2021/2022 school year as presented, to maintain the terms and conditions as the previous year. Voting Aye: Heap, Hrechko, Arlis, Ruettiger, Crye, and Barnes. Motion carried. Time: 7:03 p.m.

Buses:

MOTION: by Heap, seconded by Arlis, to approve the Bus Bid as presented, the purchase of eleven (11) 71-passenger school buses from Central States for \$89,040 per bus and a Guaranteed Buy Back of at the end of 5 years for \$30,000 and approve entering into a 5-year lease purchase agreement with American Capital in the annual lease amount of \$12,868 per bus. Voting Aye: Heap, Hrechko, Arlis, Ruettiger, Crye, and Barnes. Motion carried. Time: 7:04 p.m.

EXECUTIVE SESSION

MOTION: by Heap, seconded by Crye, to adjourn the meeting to executive session for the purpose of discussing matters related to minutes; the appointment, compensation, discipline, dismissal, employment and performance of specific employees of the District; the purchase or lease of real property for the use of the public body; pending litigation; and negotiations. Voting Aye: Heap, Hrechko, Arlis, Ruettiger, Crye, and Barnes. Motion carried. Time: 7:04 p.m.

RETURN TO OPEN SESSION

MOTION: by Arlis, seconded by Heap, to return the meeting to open session. Voting Aye: Heap, Hrechko, Arlis, Ruettiger, Crye, and Barnes. Motion carried. Time: 7:44 p.m.

ACTIONS FOLLOWING EXECUTIVE SESSION**Motion Amendment**

MOTION: by Arlis, seconded by Hrechko, to approve an amendment to the motion to note that the adjustment to the Return to Learn Instructional Model of five days a week begins after spring break. Voting Aye: Heap, Hrechko, Arlis, Ruettiger, Crye, and Barnes. Motion carried. Time: 7:52 p.m.

Closed Session Minutes

MOTION: by Heap, seconded by Crye, to approve the closed session minutes as presented:

- February 10, 2021, Committee Meeting
- February 17, 2021, Regular Meeting

Hearing no objections, the motion was approved. Time: 7:53 p.m.

Personnel

Resignations:

MOTION: by Hrechko, seconded by Crye, to accept the following resignation(s) as presented:

- Julia Riedmaier - Teacher-English - eff. 6/30/25 (due to retirement)
- Hannah Patton - Bus Aide - eff. 2/22/21
- Cassie Pershall - Bus Aide - eff. 3/4/21
- Bobby Kallien - Track -- Boys Assistant Coach - eff. 3/8/21
- Consuelo Ramirez-Arroyo - Interventionist (Math) - eff. 3/26/21

Hearing no objections, the motion was approved. Time: 7:54 p.m.

MOTION: by Crye, seconded by Barnes, to rescind the following resignation(s) as presented: Bob Marshall - Bus Driver - eff 2/16/21. The action was previously approved in error as the employee was only resigning from the *position* of bus driver to become an aide. Hearing no objections, the motion was approved. Time: 7:54 p.m.

Termination of Part-time Employment:

MOTION: by Heap, seconded by Hrechko, to approve that the employment contracts of the following part-time teachers be terminated at the conclusion of the 2020/2021 school term per customary practice, and that the Superintendent give written notice of this termination to such: Voting Aye: Heap, Hrechko, Arlis, Ruettiger, Crye, and Barnes. Motion carried. Time: 7:55 p.m.

Honorable Dismissal of Probationary Staff:

MOTION: by Hrechko, seconded by Arlis, to adopt the resolution for the honorable dismissal of probationary certified staff at the conclusion of the 2020/2021 school term, and that the Superintendent give written notice of this termination to such: Gomez, Darlena. Voting Aye: Heap, Hrechko, Arlis, Ruettiger, Crye, and Barnes. Motion carried. Time: 7:55 p.m.

Non-Renewal of Certified Staff:

MOTION: by Arlis, seconded by Barnes, to adopt the resolution for the non-renewal of probationary certified staff at the conclusion of the 2020/2021 school term, and that the Superintendent give written notice of this termination to such: Serpe, Carli. Voting Aye: Heap, Hrechko, Arlis, Ruettiger, Crye, and Barnes. Motion carried. Time: 7:56 p.m.

Leaves of Absence:

MOTION: by Arlis, seconded by Heap, to approve the following leaves of absence under the Family Medical Leave Act (FMLA) as presented:

- Tracey Adams - DC-Math, from approximately 5/3 - 8/2/21 (20 days)
- Lynn Koza - Teacher-Spec. Ed., from approximately 3/3 - 5/24/21 (60 days; intermittent)
- Rick Undesser - Teacher-Spanish, from approximately 2/19 - 6/1/21 (60 days; intermittent)
- Adam Yakush - Teacher-CTE, from approximately 5/24 - 5/28/21 (5 days)
- Elizabeth Zurava - Teacher-Spec. Ed., from approximately 3/5 - 5/24/21 (60 days; intermittent)

Hearing no objections, the motion was approved. Time: 7:57 p.m.

Re-employment of Probationary Staff (no motions are required and these are just for informational purposes):

NO MOTION (Informational): the re-employment and placement of the presented certified staff on Probationary Status for the 2021/2022 school year:

- Second Year Probationary
 - Baker, Candace
 - Caldwell, Megan
 - Cichon, Stephanie
 - Erickson, Christopher
 - Madding, Susanne
 - Micetich, Nicholas
 - Murphy, Lenora
 - Nealon, James
 - Rink, Anthony
 - Slusher, Matthew
 - Swiatek, Valerie
 - Tagler, Christopher
 - Watson, Patrick
- Third Year Probationary
 - Calder, Jonathan
 - Clark, Matthew
 - Gierke, Brooke
 - Hamiti, Jennifer
 - Highbaugh, Margaret
 - Kozola, Sarah
 - Smith, Matthew
 - Swallow, Megan
 - Welch, Marissa
 - Williams, Matthew
- Fourth Year Probationary
 - Adelman, Kyle
 - Cain, Kevin
 - Cassidy, Kathleen
 - Kipp, Kathy
 - Krol, Karolyn
 - Olszta, Andrea

NO MOTION (Informational): that the presented certified staff be re-employed and placed on tenured status at the start of the 2021/2022 school year, pursuant to statutes of the Illinois School Code: None at this time

Affirmation of Returning Administrative Staff:

MOTION: by Hrechko, seconded by Heap, to approve the affirmation of returning administrative staff as presented:

- Adams, Tracey
- Calder, Jon
- Easthon, Jeff
- Engel, Donna
- Hackney, Sean
- Holden, Hillary
- Pendergast, Chris
- Tyrell, Bob
- Wikoff, Matt
- Williams, Matt

Voting Aye: Heap, Hrechko, Arlis, Ruettiger, Crye, and Barnes. Motion carried. Time: 7:58 p.m.

Affirmation of Returning Non-Certified Directors:

MOTION: by Crye, seconded by Hrechko, to approve the affirmation of returning non-certified directors as presented:

- Edwards, Brent - Community Relations Director
- Haase, Cathy - Transportation Director
- Kelly, Jim - Technology Director
- Piper, Jason - B&G Director

Voting Aye: Heap, Hrechko, Arlis, Ruettiger, Crye, and Barnes. Motion carried. Time: 7:58 p.m.

Employment:

MOTION: by Arlis, seconded by Barnes, to approve the extracurricular appointments of returning sponsors and coaches for the 2020/21 and the 2021/2022 school year as presented:

Pavelka, Sam	FY21	SADD	Sponsor	Group IV/11	\$3,380.00	Renewal
Kelley, Ryan	FY21	Track--Boys	Asst. Coach	Group I/2 (Shared)	\$2,373.10	Renewal
Gummerson, Kevin	FY22	Cross Country	Head Coach	Group II/23	\$8,840.00	Renewal
Hencinski, Leslie	FY22	Cross Country	Asst. Coach	Group II/17	\$5,928.00	Renewal
Hopkins, Jessica	FY22	Cross Country	Asst. Coach	Group II/7	\$4,742.40	Renewal
Lundin, Nick	FY22	Cross Country	Asst. Coach	Group II/14	\$5,532.80	Renewal
Petrovic, Brian	FY22	Golf--Boys	Head Coach	Group III/21	\$6,961.60	Renewal
Petrovic, Jeff	FY22	Golf--Boys	Asst. Coach	Group III/19	\$5,290.82	Renewal
Yudzentis, Frank	FY22	Golf--Girls	Head Coach	Group III/3	\$4,351.00	Renewal
Dorick, Brad	FY22	Golf--Girls	Asst. Coach	Group III/2	\$3,306.76	Renewal
Shields, Trevor	FY22	Tennis--Girls	Head Coach	Group III/5	\$4,786.10	Renewal
Marino, Matt	FY22	Tennis--Girls	Asst. Coach	Group III/13	\$4,629.46	Renewal

Voting Aye: Heap, Hrechko, Arlis, Ruettiger, Crye, and Barnes. Motion carried. Time: 7:59 p.m.

MOTION: by Hrechko, seconded by Heap, to approve the employment of the following administrative staff member(s) for the 2021/22 school year as presented, pending proper paperwork and background check deemed favorable by the MCHS #111 Administration: Kevin Murphy - Assistant Principal (\$105,000 Annually). Voting Aye: Heap, Hrechko, Arlis, Ruettiger, Crye, and Barnes. Motion carried. Time: 8:00 p.m.

MOTION: by Arlis, seconded by Crye, to approve the employment of the following support staff member(s) as presented, pending proper paperwork and background check deemed favorable by the MCHS #111 Administration: Marlene Kirsch - Secretary to the Transportation Director (\$15.64 hr.) Voting Aye: Heap, Hrechko, Arlis, Ruettiger, Crye, and Barnes. Motion carried. Time: 8:00 p.m.

MOTION: by Arlis, seconded by Barnes, to approve the following extracurricular appointments for the 2020/21 school year as presented, pending proper paperwork and background check deemed favorable by the MCHS #111 Administration:

Matt Fisher	Lacrosse--Boys Asst. Coach	Group III/1 \$3,306.76
Karla Jacobs	Lacrosse--Boys Asst. Coach	Group III/3 \$3,306.76
Audrey Hanouw	Softball Asst. Coach	Group I/2 \$4,746.20
Nick Micetich	Track--Boys Asst. Coach	Group I/1 \$2,373.10 (shared)
Megan Caldwell	Track--Girls Asst. Coach	Group I/1 \$2,373.10 (shared)

Voting Aye: Heap, Hrechko, Arlis, Ruettiger, Crye, and Barnes. Motion carried. Time: 8:01 p.m.

FY22 Staffing:

MOTION: by Arlis, seconded by Hrechko, to approve the staffing requests for FY22 based on enrollment as presented, 1 FTE in the CTE Dept. (growth); .75 FTE in the Art Dept. (growth); 3 FTE in the Spec. Ed. Dept. (growth); RIF of part-time music and full-time Spanish teacher. Voting Aye: Heap, Hrechko, Arlis, Ruettiger, Crye, and Barnes. Motion carried. Time: 8:02 p.m.

Extracurricular Proposals:

MOTION: by Hrechko, seconded by Barnes, to approve the athletic/activity proposals as presented, creation of assistant sponsor for Winterguard and adjust and break up the stipend into two seasons (Groups 4 and 5); creation of assistant sponsor for Indoor Percussion and adjust stipend (Groups 4 and 5); creation of assistant Interact Club Sponsor at Group 6; addition of assistant coaches in Boys and Girls Basketball, Softball, and Boys and Girls Tennis. Voting Aye: Heap, Hrechko, Arlis, Ruettiger, Crye, and Barnes. Motion carried. Time: 8:02 p.m.

Salary Compensation for Non-bargaining Unit Members:

MOTION: by Barnes, seconded by Crye, to set salaries for non-bargaining unit members (administrators, support staff, and transportation) as presented. Voting Aye: Heap, Hrechko, Arlis, Ruettiger, Crye, and Barnes. Motion carried. Time: 8:03 p.m.

ADJOURNMENT

MOTION: by Heap, seconded by Hrechko, to adjourn the meeting. Voting Aye: Heap, Hrechko, Arlis, Ruettiger, Crye, and Barnes. Motion carried. Time: 8:03 p.m.

ABSTRACT OF VOTES

GRUNDY
(COUNTY)

FOR CANDIDATES ONLY

_____ Party
(For Primary only)

I, Kay T. Olson, the Election Authority of Grundy County for the Minooka Community High School District No. 111 do hereby certify that on April 21, 2021, I canvassed the returns of an election held on April 6, 2021 and I proclaim that a total of 3,204 voters requested and received ballots and I do further certify that the following list of candidates each received the number of votes herein recorded for the office listed below.

USE ONLY ONE SHEET PER OFFICE

Canvassing Board: Please list the number of votes for each candidate and include all persons receiving write-in votes. In addition, please denote the candidate(s) that have been elected to office. The canvass, must reflect the *total* number of votes received by each candidate.

OFFICE TITLE	CANDIDATE NAME (place an * next to the name(s) of candidate(s) elected)	VOTES RECEIVED
<i>Board Member (2 year unexpired term)</i>	<i>Deirdra Crye*</i>	<i>2,204</i>

I further certify that the above is a true and complete Abstract of Votes and was prepared in my presence on

April 21, 2021
(Insert Date)

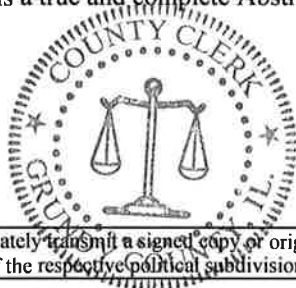

Kay T. Olson
(Grundy County Clerk)

* Each election authority shall immediately transmit a signed copy or original duplicate of its complete Abstract of Votes to each election authority having jurisdiction over any of the territory of the respective political subdivision, and to the State Board of Elections . . . " 10 ILCS 5/22-18.

ABSTRACT OF VOTES

GRUNDY
(COUNTY)

FOR CANDIDATES ONLY

Party
(For Primary only)

I, Kay T. Olson, the Election Authority of Grundy County for the Minooka Community High School District No. 111 do hereby certify that on April 21, 2021, I canvassed the returns of an election held on April 6, 2021 and I proclaim that a total of 3,204 voters requested and received ballots and I do further certify that the following list of candidates each received the number of votes herein recorded for the office listed below.

USE ONLY ONE SHEET PER OFFICE

Canvassing Board: Please list the number of votes for each candidate and include all persons receiving write-in votes. In addition, please denote the candidate(s) that have been elected to office. The canvass, must reflect the *total* number of votes received by each candidate.

OFFICE TITLE	CANDIDATE NAME (place an * next to the name(s) of candidate(s) elected)	VOTES RECEIVED
Board Member (Full 4 year term)	Cherie Barnes	1,412
	James A. Grzetic*	1,562
	John Sartori	1,517
	Owen Quast	994
	Matt Shepard*	1,637
	Michael Brozovich*	1,559

I further certify that the above is a true and complete Abstract of Votes and was prepared in my presence on

April 21, 2021
(Insert Date)



Kay T. Olson

(Grundy County Clerk)

* Each election authority shall immediately transmit a signed copy or original duplicate of its complete Abstract of Votes to each election authority having jurisdiction over any of the territory of the respective political subdivision, and to the State Board of Elections . . ." 10 ILCS 5/22-18.

STATE OF ILLINOIS }
 } SS
COUNTY OF GRUNDY }

CERTIFICATE OF ELECTION

This is to Certify, that **Deirdra Crye**

was duly Elected to the Office of **Board Member (2 year unexpired term)**

in and for the **Minooka Community High School District No. 111**

in the County of Grundy and State of Illinois, at the Consolidated Election
held on April 6, 2021.

In Witness whereof, I have hereunto set my hand and seal on April 21, 2021.



Kay T. Olson
Grundy County Clerk

STATE OF ILLINOIS }
 } ss
COUNTY OF GRUNDY }

CERTIFICATE OF ELECTION

This is to Certify, that **James A. Grzetich**
was duly Elected to the Office of **Board Member**
in and for the **Minooka Community High School District No. 111**
in the County of Grundy and State of Illinois, at the Consolidated Election
held on April 6, 2021.

In Witness whereof, I have hereunto set my hand and seal on April 21, 2021.



A handwritten signature in black ink that reads "Kay T. Olson". The signature is written in a cursive style.

Kay T. Olson
Grundy County Clerk

STATE OF ILLINOIS }
 }
COUNTY OF GRUNDY } SS

CERTIFICATE OF ELECTION

This is to Certify, that **Matt Shepard**
was duly Elected to the Office of **Board Member**
in and for the **Minooka Community High School District No. 111**
in the County of Grundy and State of Illinois, at the Consolidated Election
held on April 6, 2021.

In Witness whereof, I have hereunto set my hand and seal on April 21, 2021.



A handwritten signature in black ink that reads "Kay T. Olson".

Kay T. Olson
Grundy County Clerk

STATE OF ILLINOIS }
 }
 } SS
COUNTY OF GRUNDY }

CERTIFICATE OF ELECTION

This is to Certify, that **Michael Brozovich**
was duly Elected to the Office of **Board Member**
in and for the **Minooka Community High School District No. 111**
in the County of Grundy and State of Illinois, at the Consolidated Election
held on April 6, 2021.

In Witness whereof, I have hereunto set my hand and seal on April 21, 2021.



A handwritten signature in black ink that reads "Kay T. Olson".

Kay T. Olson
Grundy County Clerk

School Board Member Oath of Office



“I, _____, do solemnly swear (or affirm) that I will faithfully discharge the duties of the office of member of the Board of Education (or Board of School Directors) of _____, in accordance with the Constitution of the United States, the Constitution of the State of Illinois, and the laws of the State of Illinois, to the best of my ability.

“I further swear (or affirm) that:

“I shall respect taxpayer interests by serving as a faithful protector of the school district's assets;

“I shall encourage and respect the free expression of opinion by my fellow board members and others who seek a hearing before the board, while respecting the privacy of students and employees;

“I shall recognize that a board member has no legal authority as an individual and that decisions can be made only by a majority vote at a public board meeting; and

“I shall abide by majority decisions of the board, while retaining the right to seek changes in such decisions through ethical and constructive channels.”

BOARD MEMBER

DISTRICT

BOARD PRESIDENT

SUPERINTENDENT

DATE



Organizing the Board

Your Guide to Seating New
Members, Electing Officers, and
Administering the Oath of Office

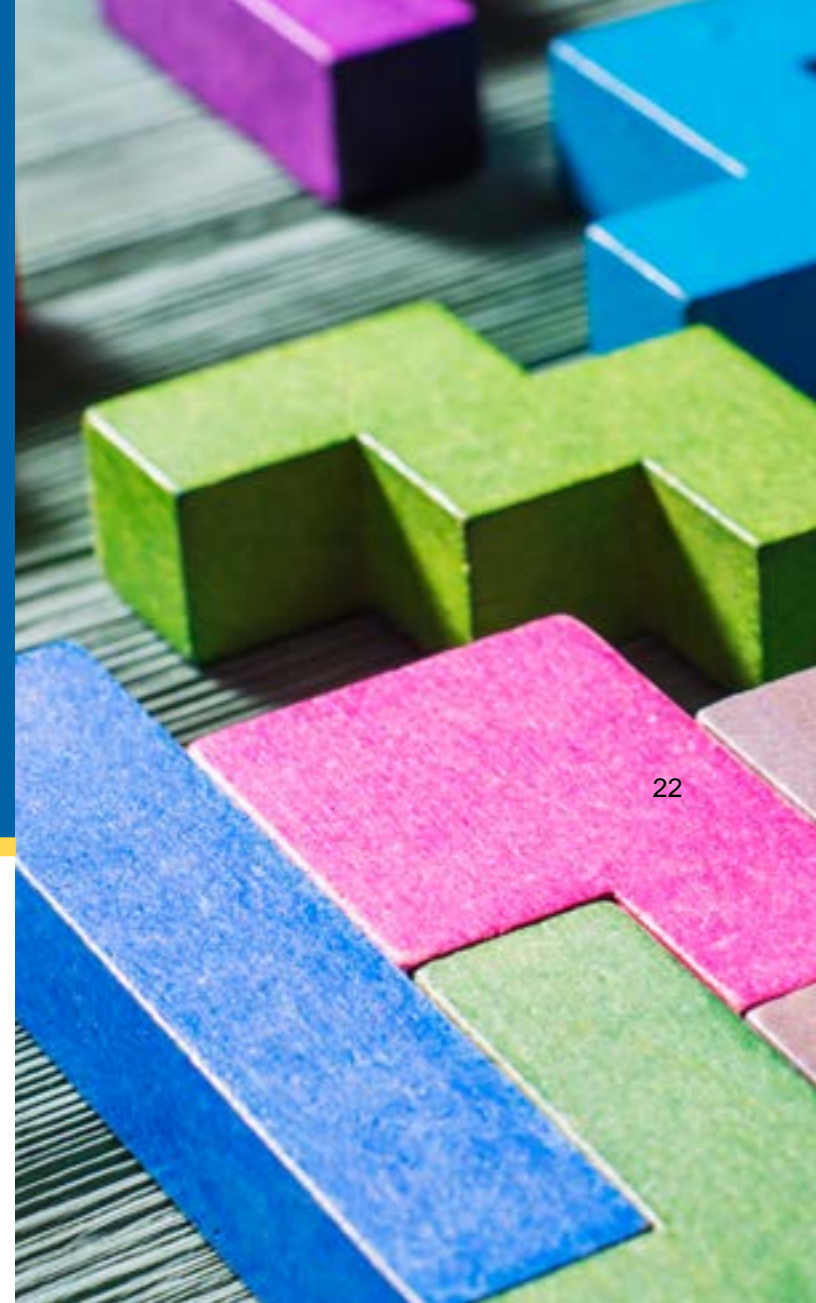

Introduction

State law requires each school board to hold an organizational meeting following the consolidated election held in odd-numbered years. This document describes those legal requirements and provides a process for smoothly and efficiently seating new board members and organizing the school board.

The board should have a policy in place to address the organizational meeting and will want to ensure the processes used in the organizational meeting are aligned with that policy. In addition to the legally required process, board members may weigh other considerations, including a show of respect for the traditions of the board and expressions of gratitude for retiring members.

The organizational meeting must be held in open session, and the board must:



Administer the oath of office



Elect officers



Seat new members



Set a time and place for regular meetings.

If officers are elected to one-year terms, the board must hold an organizational meeting every year primarily for the purpose of electing officers.

Even though its members change, a school board is a continuing entity. The board does not need to re-hire district staff, re-approve contracts, or re-adopt the board policy manual. These unnecessary actions may cause confusion and could create legal issues for the district.



Seating the New Board Members

Within 21 days following the consolidated election, the district will receive an abstract of votes from the election authority or election commission. In most cases, the election authority is the county clerk. The abstract of votes is official notification to the district of the election winners. It provides the basis for announcing the new members who will be seated on the board.

The board must seat its new members within 28 days of the consolidated election. If a regular board meeting date falls after receiving the abstract of votes and prior to 28 days following the election, the board may choose to seat its new members at its regular meeting. If no regular meeting falls in that time frame, by law a special meeting must be called.

Before the new board members are seated, outgoing board members may approve the minutes of board meetings that have not yet come up for approval. This action is merely an approval of the record of business already conducted. No business other than seating new members should be transacted by the outgoing board members at the organizational meeting.

Before an individual takes a seat on the board, he or she must take an official oath, administered as determined by the board, in

substantially the form as written in the School Code. Districts often ask whether this applies only to newly elected board members or to all members elected and/or re-elected. To assure compliance, members that are newly elected or appointed and returning by re-appointment and/or re-election should take the oath.



Boards should check their local board policy to determine how the oath is taken. School boards may develop whatever process²⁴ and/or ceremony they choose and include it in board policy. Some options are

- The oath is administered by the board president, the board secretary, the superintendent, or the board's attorney, etc.
- Each individual taking the oath may read the oath aloud.
- A group of members or the entire board may take the oath simultaneously.

For districts that choose to formally observe this occasion, IASB has created an Oath of Office certificate located at www.iasb.com/training/oath.cfm.

Each School Board member, before taking his or her seat on the Board, shall take the following oath of office:

I, (name), do solemnly swear (or affirm) that I will faithfully discharge the duties of the office of member of the Board of Education of *(name of School District)*, in accordance with the Constitution of the United States, the Constitution of the State of Illinois, and the laws of the State of Illinois, to the best of my ability.

I further swear (or affirm) that:

I shall respect taxpayer interests by serving as a faithful protector of the school district's assets;

I shall encourage and respect the free expression of opinion by my fellow board members and others who seek a hearing before the board, while respecting the privacy of students and employees;

I shall recognize that a board member has no legal authority as an individual and that decisions can be made only by a majority vote at a public board meeting;

I shall abide by majority decisions of the board, while retaining the right to seek changes in such decisions through ethical and constructive channels;

As part of the Board of Education, I shall accept the responsibility for my role in the equitable and quality education of every student in the school district;

I shall foster with the Board extensive participation of the community, formulate goals, define outcomes, and set the course for *(name of school district)*;

I shall assist in establishing a structure and an environment designed to ensure all students have the opportunity to attain their maximum potential through a sound organizational framework;

I shall strive to ensure a continuous assessment of student achievement and all conditions affecting the education of our children, in compliance with State law;

I shall serve as education's key advocate on behalf of students and our community's school *(or schools)* to advance the vision for *(name of school district)*; and

I shall strive to work together with the district superintendent to lead the school district toward fulfilling the vision the board has created, fostering excellence for every student in the areas of academic skills, knowledge, citizenship, and personal development.

105 ILCS 5/10-16.5





Election of Board Officers

The law does not establish a method for electing officers. Each board must establish its own policy regarding the organizational meeting, including terms of office, selection of officers, and nominating and voting processes. The Open Meetings Act requires the election of officers by open vote,

not by secret ballot.

To launch the process of electing officers, someone should be selected to serve as the president pro tempore (temporary president) until the board elects a permanent president. The president of the board is the first officer to be elected and immediately assumes duties of the chair to preside over the election of other officers.

Appointment of President Pro Tem and Secretary Pro Tem

The board may establish its own process for selecting a president pro tem. Any seated board member can serve as a president pro tem. Best practice would indicate choosing a board member who

has been through an organizational meeting in the past. Some boards appoint the current president or vice president as the president pro tem if he or she is still on the board.

If a board does not use a recording secretary (superintendent's secretary or other district employee), the board should appoint a secretary pro tem to keep a record of the board's actions until a new board secretary is elected.

Nominations and Voting

26

Board President

The board's local process determines how nominations and voting are done; a simple process works best. The first order of business is nominations. Anyone can make a nomination, including self-nominations. Nominations do not require a second. Election of an officer requires a majority of those voting. This entire process must occur during an open meeting, and voting must not be by secret ballot.

- If only one member is nominated for president, the president pro tem may 1) cast a unanimous ballot and declare that can-

didate elected, or 2) ask for a show of hands or a voice vote in which each member has an opportunity to vote “yes” or “no” for the nominated candidate.

- If two or more members are nominated for president, a show of hands or roll call voice vote is necessary. The member receiving a majority of the votes cast is elected. If there is a tie or no one receives a majority of votes cast, a second vote must be taken. Additional votes must be taken as necessary to elect one candidate. If no candidate is elected, the president pro tem continues to serve until a president elected.

Vice President, Secretary, and Treasurer

Once elected, the board president presides over the meeting as the board proceeds to elect its vice president, secretary, and treasurer (if the board elects a secretary and/or treasurer from among its members), using the same nomination and voting process that the board used to elect the president.

State law assigns specific duties to board officers; however, each school board may require its officers to perform other duties. Board policy should be consulted for officer duties.



Choosing Officers

Choosing the best individuals to lead the board is important. Some things to consider when choosing board officers include:

President

The board president presides at all meetings and calls special meetings, in addition to many other duties. Because the president becomes the public face of the board, members may want to select someone with recognized leadership skills and the abilities to effectively speak for the board and to work together with the superintendent to plan and conduct successful meetings. Basing the choice on these considerations is generally more effective than either basing the choice upon longevity or rotating the office so that each board member takes a turn serving as president. The individual chosen for the post should possess the qualities to do the job well and be prepared to satisfy the major time commitment required.

Vice President

The vice president performs the duties of the president in the event of a vacancy or if the president is absent or unable to perform his or her duties. A board is well advised to select a vice president who has many of the same skills and qualities of the president.

Secretary

The secretary may be a board member or non-member at the discretion of the board. The secretary is the only officer who may receive compensation. Compensation of a board member chosen as secretary is limited, however, to a maximum set by statute, and the amount must be established at least 180 days before the term of office begins. Compensation of a non-member board secretary is not subject to a statutory maximum. Even when a board member is elected board secretary, best practice dictates that a recording secretary be used to keep the minutes, freeing all elected board members to take an active role in board discussion and deliberation.

Treasurer

The School Code specifies the qualifications and term lengths for treasurer. In some districts, but not all, a school board member may be elected treasurer. An appointed treasurer (non-member of the board) serves at the pleasure of the board rather than for a fixed term.

The following sample scripts illustrate several of the concepts in this publication.

Taking the oath of office

Continuing president or president pro tem: "I will now administer the oath of office to the newly elected members of the board of education."

Continuing president or president pro tem (to new board members):
"Please repeat after me: ... "

Nominations

President pro tem: "Nominations are now in order for the office of president."

Member: "I nominate Helen Smith." 28

President pro tem: "Helen Smith is nominated."

Are there any other nominations for the office of president?"

President pro tem: "Hearing no further nominations, the nominations for the office of president are closed."

Electing the president (if there is only one nomination, the president pro tem may recognize the election without asking for votes.)

President pro tem: "Helen Smith being the only candidate nominated for the office of president, the chair hereby declares her elected by acclamation and directs the secretary to so record in the minutes."

(continued next page)

Electing the president (if there are several nominations, the candidate receiving the majority of votes cast wins. Abstentions should be counted with the majority of votes cast.)

President pro tem: "All in favor of Helen Smith for the office of president raise their hands."

Then: "All in favor of Paul Jones for the office of president raise their hands."

Then: "The secretary (or secretary pro tem) reports the vote is 5-2 in favor of Helen Smith. By receiving a majority of the votes cast, Helen Smith is elected president of this board of education."

Electing the president (if more than two candidates are nominated, one candidate must receive a majority of the votes cast to declare a winner.)

President pro tem: "[The secretary reports that] Three candidates have split the vote [3-2-2 or 3-3-1]. No one candidate has received a majority of the votes cast. Voting will continue until one candidate receives a majority of the votes cast. At this time, does any candidate choose to drop out of the contest for the office of president before we vote again?"

Establishing Regular Meetings



All school boards are required to hold regular meetings, establish a schedule for them, and provide public notice as required by the Open Meetings Act. Once the newly elected members have been seated and the permanent board officers are elected, the board sets the dates and location(s) for its regular meet-

ings.

29

After new board members have taken the oath, officers have been elected, and the meeting dates and locations have been set, the board goes on to any items of business remaining on the agenda.

Board Traditions

Some school boards have established the tradition of adjourning sine die before reorganizing, as detailed in Roberts Rules of Order. "Sine die" is a Latin expression meaning "indefinitely or without a date set for a future meeting." This procedure is not required by law and has no legal significance. The implication

is that an “old board” is permanently adjourned and that a “new board” is convened. However, in regard to contracts, formally adopted board policy, and other agreements, the board is seen as a corporate body that continues regardless of changes in its membership.

Another tradition in many districts is that once the new board members have been seated, members retiring from the board who are present are recognized for their service to the district. Boards provide this recognition in a small ceremony after the new board members have been seated. This can take the form of a presentation of a plaque, framed certificate, or other memento acknowledging board service. The specifics of the ceremony are a matter of local tradition or preference.

Some districts host a social function for both the incoming and outgoing board members, either before or after the organizational meeting. The reception, which does not need to be elaborate, is an opportunity to recognize the contributions of the outgoing board member(s) as well as to welcome the new member(s) of the board and introduce them to the public and district employees.

Sources

Illinois Election Code

- Article 17, Conduct of Elections and Making Returns (10 ILCS 5/17-22)
- Article 22, Canvassing Votes, (10 ILCS 5/22-17 and 5/22-18)

Illinois School Code

- Article 10, School Boards (105 ILCS 5/10-1 et seq.)

Illinois School Law Survey

- Chapter 4, School Election Procedures
- Chapter 5, School Board Officers 30
- Chapter 6, School Board Meetings

Coming to Order: A Guide to Successful School Board Meetings

- Chapter 10, The New Team: Reorganizing the School Board



MINOOKA COMMUNITY HIGH SCHOOL DISTRICT #111

Mission: To inspire and motivate our students with an educational experience that leads to achievement and success.

To: Kenny Lee, Superintendent

From: John Troy, Assistant Superintendent

Date: May 4, 2021

Re: List of depositories

The following financial institutions are approved depositories for district funds, as well any agency funds the district may oversee:

CIBC
120 South LaSalle Street
Chicago, IL 60603

U.S. Bank
800 Nicollet Mall
Minneapolis, MN 55402

BMO Harris Bank
111 West Monroe Street
Chicago IL 60603

ISDLAF (Illinois School District Liquid asset fund)
2135 CityGate Lane
7th Floor
Naperville, IL 60563

Mesirow Financial
353 North Clark Street
Chicago, IL 60654

MINOOKA COMMUNITY HIGH SCHOOL
DISTRICT #111
BOARD OF EDUCATION MEETINGS

Board meetings are scheduled on the third Wednesday of each month. Exceptions are noted. All meetings are held at 6:00 p.m. in the Academic Resource Center of Minooka Community High School, unless moved elsewhere, as posted below:

BOARD MEETINGS-Wednesdays

June 16, 2021

July 21, 2021

August 18, 2021

September 15, 2021

October 20, 2021

November 17, 2021

December 15, 2021

January 19, 2022

February 16, 2022

March 16, 2022

April 20, 2022

May 18, 2022

June 15, 2022

*Exceptions

**Additionally, committee of the whole meetings will be held on the second Wednesday of each month at 5:30 p.m. and are held in Room 263 at Central Campus.

Copies to: Morris Herald News

Cc: Supt. – DO
Dir. B&F – DO
Principal – Central
Dir. C&I
Asst. Principal – South/Central
AD Athletics - Central
AD Activities – South
Secretary to the Principal – Central
Secretary to the AD – Central
Secretary to the AD – South (bldg. usage)
Secretary to the Dir. C&I
Comm. Rel. – Central/South
B&G Dir. – Central (bldg. usage)
B&G Dir. – South (bldg. usage)
Accts. Pay. – DO
MEA President
SSU President
Quest
Web Site
MDH
Grundy News

Approved 5/4/2021

E-mailed

Db(FM)
Bd Cal
Website
EventLink

Committee Meetings 2 nd Wednesday 5:30 P.M.	Board Meetings 3 rd Wednesday 6:00 P.M.
Committee Meetings	Board Meetings
June 9, 2021	June 16, 2021
July 14, 2021	July 21, 2021
August 11, 2021	August 18, 2021
September 8, 2021	September 15, 2021
October 13, 2021	October 20, 2021
November 10, 2021	November 17, 2021
December 8, 2021	December 15, 2021
January 12, 2022	January 19, 2022
February 9, 2022	February 16, 2022
March 9, 2022	March 16, 2022
April 13, 2022	April 20, 2022
May 11, 2022	May 18, 2022
June 8, 2022	June 15, 2022

*Exceptions

**MINOOKA COMMUNITY HIGH SCHOOL
BOARD OF EDUCATION COMMITTEE ASSIGNMENTS
2021-2023**

* * *

<u>B & G</u>	<u>CO-CURR</u>	<u>CURR</u>	<u>FIN</u>	<u>PERS</u>	<u>POL</u>	<u>SPEC ED</u>	<u>TECH</u>	<u>TRNS</u>	
		Heap	Crye	Brozovich	Hrechko				
Hrechko			Heap				Crye	Hrechko	
Heap	Crye	Crye	Brozovich	Hrechko	Brozovich	Crye			

GAVC Representative:

GCSEC Representative:

IASB Representative:

Equity & Diversity Committee – Implementation and board member assignment

FINANCE

The finance committee typically meets monthly on the second Wednesday of the month (the Wednesday prior to the board meeting). The committee reviews bills and payments, leases and contracts, budget information, as well as other financial implications for the district.

BUILDINGS & GROUNDS

The buildings and grounds committee typically meets on an as needed basis to review building projects.

PERSONNEL

The personnel committee typically meets monthly on the second Wednesday of the month (the Wednesday prior to the board meeting) to review personnel actions (resignations, employments, leaves, etc.).

POLICY

The policy committee typically meets quarterly to review recommendations from the Illinois Association of School Boards regarding district policies as well as any other topics for overall district governance.

TRANSPORTATION

The transportation committee typically meets on an as needed basis for such items as reviewing the district's fleet of vehicles and the transportation facility.

36

CURRICULAR

The curricular committee typically meets 2-3 times in the fall to review course additions/deletions/changes as well as textbooks.

CO-CURRICULAR

The co-curricular committee typically meets on an as needed basis for reviewing the district's clubs and teams.

TECHNOLOGY

The technology committee typically meets on an as needed basis for reviewing the district's technology plans.

SPECIAL EDUCATION

In addition to the board having a representative on the Grundy County Special Education Cooperative Board, the committee meets quarterly to review the special education department at MCHS.

GAVC

Typically, a representative of the board attends the Grundy Area Vocation Center Board monthly meetings.

Code of Conduct

for members of school boards

As a member of my local school board, I will do my utmost to represent the public interest in education by adhering to the following standards and principles:

1. I will represent all school district constituents honestly and equally and refuse to surrender my responsibilities to special interest or partisan political groups.
2. I will avoid any conflict of interest or the appearance of impropriety which could result from my position, and will not use my board membership for personal gain or publicity.
3. I will recognize that a board member has no legal authority as an individual and that decisions can be made only by a majority vote at a board meeting.
4. I will take no private action that might compromise the board or administration and will respect the confidentiality of privileged information.
5. I will abide by majority decisions of the board, while retaining the right to seek changes in such decisions through ethical and constructive channels.
6. I will encourage and respect the free expression of opinion by my fellow board members and will participate in board discussions in an open, honest and respectful manner, honoring differences of opinion or perspective.
7. I will prepare for, attend and actively participate in school board meetings.
8. I will be sufficiently informed about and prepared to act on the specific issues before the board, and remain reasonably knowledgeable about local, state, national, and global education issues.
9. I will respectfully listen to those who communicate with the board, seeking to understand their views, while recognizing my responsibility to represent the interests of the entire community.
10. I will strive for a positive working relationship with the superintendent, respecting the superintendent's authority to advise the board, implement board policy, and administer the district.
11. I will model continuous learning and work to ensure good governance by taking advantage of board member development opportunities, such as those sponsored by my state and national school board associations, and encourage my fellow board members to do the same.
12. I will strive to keep my board focused on its primary work of clarifying the district purpose, direction and goals, and monitoring district performance.

Superintendent Report BOE Meeting 05.04.21

Principal

MCHS Honors Class of 2021

In a year like no other, we plan on celebrating our Class of 2021. Our students will be celebrated in with the following events:

- May 6: Senior Scholar Night
- May 14: Senior Sunset
- May 16: Graduation

All events will follow IDPH guidelines and will practice social distancing.

Parent University

MCHS is proud to offer a Parent University on Wednesday, May 5, as parents prepare for their student's high school experience by attending information sessions on the services and opportunities MCHS has to offer. Topics include: technology, activities and athletics, college 101, managing emotions, and a virtual tour of In Plain Sight. Thank you to Jamie Soliman, Matt Wikoff and the members of Strategic Plan Goal Two.

#MCHSProud

- Thank you to Heather Paulsen and Marci Jordan for planning and supporting the Senior Scholarship Event and all our sponsors supporting our students financially.
- Thank you to our class sponsors, graduation committee members, and Hillary Holden for all their hard work and efforts to provide a safe and meaningful experience for our students and their families as we celebrate the Class of 2021.

Curriculum and Instruction

JJC has begun partnerships with several high schools, including Minooka, to discuss their Equity in Dual Credit Initiative. During our initial meeting, representatives from JJC explained how they wish to contribute, as part of our

partnership, to efforts to increase dual credit participation rates among historically underrepresented students of color.

The New Teacher Mentor program will have its final meeting of the year on May 6, and Brad Dorick and Andres Torres have done excellent work this year to provide support and professional learning opportunities to new teachers in our district.

Assessment coordination was a large focus of March and April. The SAT was administered at Central Campus on April 13 to all junior students, and the makeup exam was given on April 27. Thanks to Jessica Hopkins and Kristin Carlson for their help with test coordination. AP testing begins May 4 and continues throughout the month of May. Thanks to Bobbi White and Chris Pendergast for their test coordination help since this year's AP testing was offered in both paper and digital formats.

Finance

Audit - We have put our audit for the 2020-2021 school year out to bid. Last year the board approved a 1-year contract with our current Auditor, Mack & Associates. Responses are due on May 11, 2021. We will present the bid responses to the finance committee on May 12, 2021, and seek approval for awarding the audit bid at the May 19, 2021, Board meeting.

Transportation Building Drainage - The transportation drainage project was put out to bid and the low bidder was Winninger Excavating. District 201 Board of Education, who owns 50% of the transportation building, approved the award of the bid to Winninger at their meeting on April 19. The administration is requesting that our Board also award the bid to Winninger. Work is expected to start immediately. The Board package contains the details of the bid.

Amended Budget - A tentative amended budget will be presented to the Board at the May 12, 2021, committee meeting. In accordance with school code a notice of the

amended budget will be published and the tentative amended budget will be available for public review for 30 days prior to approval on June 16, 2021.

Community Relations

MCHS The Nook 111 Live Stream Session:

Hosted a Live Streaming session on Facebook and YouTube:

The session included discussions on the Return to Learn Update for students when they returned from Spring Break. Guests included Dr. Kenny Lee and Dr. Bryan Zwemke. The session explained the new 5-day a week school model, social and emotional support resources for students, and various upcoming events such as prom, football, soccer, and the spring musical. To date the video has been viewed over **2,300** times.

Student of the Term - Q3

Produced the “Student of the Term” video for third term award recipients - The Student of the Term award recognizes one student from each department for his or her outstanding performance throughout the nine-week period. The post had a reach of **1,200**.

Miscellaneous Items

- Celebrated the following: Assistant Principal Week, Dean Appreciation Week, National Librarian Day, and Administrative Professionals Day.
- Posted Opening Day photos and videos of the Track and Baseball season on our social media channels: To date the videos have been viewed **1,902** times and the posts received **6,974** impressions.

4) Press Releases

Wrote and submitted 3 press releases that were picked up by the Morris Herald New, Joliet Herald News, and WCSJ News. The 3 press releases included:

Minooka Community High School Announces Student of the Term Nominations for 3rd Quarter

Minooka Community High School Senior Named Rotary Club “Student of the Month” for March

Minooka Community High School Varsity Dance Team Places Third at the IHSA Dance State Finals



MINOOKA

COMMUNITY HIGH SCHOOL

District #111 mchs.net

*Mission: Strengthen **M**astery, **C**ollaboration, **H**igh Expectations, and **S**uccess for All Students.*

To: Dr. Kenny Lee, Board of Education

From: Dr. Bryan Zwemke

Date: May 4, 2021

Subject: May Board Report

MCHS Honors Class of 2021

In a year like no other, we plan on celebrating our Class of 2021. Our students will be celebrated in with the following events:

- May 6: Senior Scholar Night
- May 14: Senior Sunset
- May 16: Graduation

All events will follow IDPH guidelines and will practice social distancing.

Return to Learn 2021 Tentative Plans

We are in the process of meeting with stakeholders to determine the best course of action for next school year. Remote learning may be significantly different from the experience MCHS students received this school year. Courses may be offered through an MCHS staff member online, or via Edgenuity, which are online courses that include all lessons and assessments. Our Department Chairs, Instructional Team, Administration and MEA have engaged in meaningful dialogue to help support our students and staff for next school year. Communication to outline our next school year and application are included below:

- [Return to Learn 2021 Communication](#)
- [Remote Learning Application](#)

Parent University

MCHS is proud to offer a Parent University on Wednesday, May 5, as parents prepare for their student's high school experience by attending information sessions on the services and opportunities MCHS has to offer. Topics include: technology, activities and athletics, college 101, managing emotions, and a virtual tour of In Plain Sight. Thank you to Jamie Soliman, Matt Wikoff and the members of Strategic Plan Goal Two.

#MCHSProud

- Thank you to Heather Paulsen and Marci Jordan for planning and supporting the Senior Scholarship Event and all our sponsors supporting our students financially.
- Thank you to our class sponsors, graduation committee members, and Hillary Holden for all their hard work and efforts to provide a safe and meaningful experience for our students and their families as we celebrate the Class of 2021.

John Troy
Assistant Superintendent & General Counsel

Board Report

April 29, 2021

1. **Audit** - We have put our audit for the 2020-2021 school year out to bid. Last year the board approved a 1-year contract with our current Auditor, Mack & Associates. Responses are due on May 11, 2021. We will present the bid responses to the finance committee on May 12, 2021, and seek approval for awarding the audit bid at the May 19, 2021, Board meeting.
2. **Transportation Building Drainage** - The transportation drainage project was put out to bid and the low bidder was Winninger Excavating. District 201 Board of Education, who owns 50% of the transportation building, approved the award of the bid to Winninger at their meeting on April 19. The administration is requesting that our Board also award the bid to Winninger. Work is expected to start immediately. The Board package contains the details of the bid.
3. **Amended Budget** - A tentative amended budget will be presented to the Board at the May 12, 2021, committee meeting. In accordance with school code a notice of the amended budget will be published and the tentative amended budget will be available for public review for 30 days prior to approval on June 16, 2021.



MINOOKA

COMMUNITY HIGH SCHOOL

District #111 mchs.net

*Mission: Strengthen **M**astery, **C**ollaboration, **H**igh Expectations, and **S**uccess for All Students.*

Dr. Janel Grzetich, Director of Curriculum and Instruction
Board Report May 4, 2021

Curriculum

I recently joined the group, Illinois Coalition of Educational Equity Leaders, and attended a meeting to hear connections to ISBE's strategic plan. During the meeting, several districts shared their work related to equity and inclusion. I also attended several Chicagoland Area Directors of Curriculum and Assessment meetings, during which districts shared ongoing plans for summer and fall learning.

JJC has begun partnerships with several high schools, including Minooka, to discuss their Equity in Dual Credit Initiative. During our initial meeting, representatives from JJC explained how they wish to contribute, as part of our partnership, to efforts to increase dual credit participation rates among historically underrepresented students of color.

The New Teacher Mentor program will have its final meeting of the year on May 6th, and Brad Dorick and Andres Torres have done excellent work this year to provide support and professional learning opportunities to new teachers in our district.

Assessment

Assessment coordination was a large focus of March and April. The SAT was administered at Central Campus on April 13th to all junior students, and the makeup exam was given on April 27th. Thanks to Jessica Hopkins and Kristin Carlson for their help with test coordination. AP testing begins May 4th and continues throughout the month of May. Thanks to Bobbi White and Chris Pendergast for their test coordination help since this year's AP testing was offered in both paper and digital formats.



MINOOKA

COMMUNITY HIGH SCHOOL

Director of Community Relations Report To The Board Of Education *Brent Edwards - May 4, 2021*

A. Recognitions

- None

B. Processed FOIA Requests

- **Ted Trujillo (received 3/9/2021 | responded 3/16/2021)**

...Requesting the exact amount paid to the Native American Guardians Association or anyone representing NAGA. Exactly who paid for this speaker and who recommended NAGA to speak to the Minooka high school mascot taskforce.

...Requesting any and all notes taken during the meeting with the speaker during the time the speaker was addressing the Minooka high school mascot taskforce by:

Mike Brozovich
Brent Edwards
Laura Hrechko
Kenny Lee
John Troy
Bryan Zwemke

...Requesting any and all correspondence with NAGA, and or any representative of the Native American guardian association by anyone representing Minooka high school and or anyone on the Minooka high school mascot taskforce.

...The full name of the speaker that represented NAGA and any and all credentials that were provided by the speaker or anyone representing NAGA. This should include tribal affiliation and exactly what tribe the speaker is claiming to represent. This should also include any proof provided to Minooka high school by the speaker that shows actual tribal enrollment.

.... Any and all verifications that Minooka high school did to verify that the speaker is actually Native American and is a member of a Federally recognized Tribe.

... Was this speaker and taskforce members recorded? If not then why was this not recorded? If it was recorded then the exact link where it can be viewed.

.... Any and all contact information including anyone that has had any voice, phone, email, or any other communication with anyone from Minooka high school.

.... Any and all proof that anyone on the Minooka high school mascot taskforce that claims to be Native has provided to back up the claim of being Native.

... Any and all verification that Minooka high school has done to verify anyone claiming to be Native on the mascot taskforce is actually Native.

... Exactly how many participants on the Minooka high school mascot taskforce are actually enrolled tribal members and exactly how many members that claim to be Native are self identifying?

- **Ted Trujillo (received 3/10/2021 | responded 3/16/2021)**

... Requesting the exact amount that Eunice Davidson was paid to speak to the Minooka high school mascot taskforce and exactly who paid for her to speak.

... Requesting any and all contact information for Eunice and any information that she provided to prove any tribal affiliation including proof that she is an enrolled tribal member and exactly what tribe she is claiming to be enrolled with.

...Requesting if she disclosed the fact that she is a NAGA member and if she did disclose this information then exactly who was the person that this disclosure was made to that was representing Minooka high school?

...Any and all communication between anyone representing Minooka high school and Eunice Davidson which must include notes from any phone calls faxes emails etc.

...The exact link to the recording of Eunice speaking to the Minooka high school mascot taskforce.

- **Lori Lakota (received 3/11/2021 | responded 3/16/2021)**

...Closed session recordings for all regular board meetings and committee meetings from April 1, 2019 to June 1, 2019.

- **Joe Sutton (received 3/22/2021 | responded 3/17/2021)**

...Requesting the district's current website and/or content management system (CMS) provider contract.

- The district's current alerts and/or emergency notification provider contract.
- The district's current mobile app provider contract.
- The district's current learning management system (LMS) provider contract.

- **Ted Trujillo (received 3/15/2021 | responded 3/19/2021)**

... The exact amount charged and or paid to John Kane for speaking to the Minooka high school mascot taskforce on 3/15/2021.

...The exact link of where the recording can be found of John Kane talking to the Minooka high school Native taskforce on 3/15/2021

- **Lori Lakota (received 3/17/2021 | responded 3/19/2021)**

...I am requesting a copy of the MCHS Regular Board of Education written minutes from April 1,2019 to June 30th 2019.

- **Ted Trujillo (received 3/15/2021 | responded 3/19/2021)**
 ...This is a FOIA request for the recording of the Minooka high school mascot taskforce meeting that took place on 3/22/2021.

- **SMART Local 265 (received 4/8/2021 | responded 4/9/2021)**
 ...Requesting information for the new construction, renovation and/or maintenance work planned for any building owned or leased by your district which includes the scopes listed below. In addition, if any contracts have already been awarded, please include the names and contact information of those contractor(s) and/or sub-contractor(s).
 - HVAC (Heating, Air Conditioning, Ventilation), Exhaust Systems.
 - Architectural Metals used for weatherproofing and/or ornamental purposes.
 - Gutters and /or Downspouts.
 - New installation and/or replacement of lockers.
 - New installation and/or replacement of toilet partitions.
 - Kitchen Renovations.
 - Current HVAC Maintenance Contracts.

- **Illinois Farmers Insurance Company (received 4/9/2021 | responded 4/16/2021)**
 ...Respecting the school board meetings which took place on or about May 21, 2019 and March 14, 2019, I am seeking the following:
 - Any video or audio recordings
 - Copies of transcripts of the meetings
 - Copies of the minutes of the meetings
 - The agenda of the meetings
 - A list of those in attendance at each meeting representing the board, or any other known participants.
 ...In addition to the above, I'm requesting the following:
 - Any non-privileged communications between the board and former Principal Kiesewetter regarding his resignation.
 - Any emails or other communications regarding the resignation of former school board member Lori Lakota or the events leading to her resignation.

- **Ted Trujillo (received 4/26/2021 | responded 4/30/2021)**
 ...the sample syllabus that Minooka high school received from the Native American Guardian's Association (NAGA) on their educational program and any and all correspondence that accompanied this sample syllabus to Minooka high school and or Kenny Lee from the Native American Guardians Association (NAGA).

C. Social Media Update – (Last 28 days)

1. Facebook*

Followers:	4,878
New Followers:	21
Reach:	11,068
Post Engagement:	4,293
Videos:	754
2. Twitter**

Followers:	2,450
Impressions:	51.9K

3. Instagram	
Followers:	1,980
4. MCHS.net***	
Unique Pageviews	46,886
Pageviews	56,746
5. YouTube	
Subscribers	375
Views	1,046
Impressions	15.2K

D. Update Item

1) MCHS The Nook 111 Live Stream Session:

Hosted a Live Streaming session on Facebook and YouTube:

The session included discussions on the Return to Learn Update for students when they returned from Spring Break. Guests included Dr. Kenny Lee and Dr. Bryan Zwemke. The session explained the new 5-day a week school model, social and emotional support resources for students, and various upcoming events such as prom, football, soccer, and the spring musical. To date the video has been viewed over **2,300** times.

2) Student of the Term - Q3

Produced the “Student of the Term” video for third term award recipients - The Student of the Term award recognizes one student from each department for his or her outstanding performance throughout the nine-week period. The post had a reach of 1,200. Congratulations to the following students:

CTE - Madison Hanna
 English - Chris Johnson
 English - Yuanjie Li
 Math - Jada Evans
 Music - Evelyn Maruszak
 Phs. Ed. - Casey Swanson
 Driver Ed. - Anthony Ortega
 Science (South Campus) - Sana Polizzi
 Science (Central Campus) - Rachel Boehning
 Social Studies - Ramon Vazquez
 World Language - Faith Hayes
 World Language - Paige Yance

3) Miscellaneous Items

Celebrated the following: Assistant Principal Week, Dean Appreciation Week, National Librarian Day, and Administrative Professionals Day.

Posted Opening Day photos and videos of the Track and Baseball season on our social media channels: To date the videos have been viewed **1,902** times and the posts received **6,974** impressions.

4) Press Releases

Wrote and submitted 3 press release that were picked up by the Morris Herald New, Joliet Herald News, and WCSJ News. The 3 press releases included:

MCHS Announces Student of the Term Nominations for 3rd Quarter
MCHS Senior Named Rotary Club “Student of the Month” for March

MCHS Varsity Dance Team Places Third at the IHSA Dance State Finals

Additional Items

- Routine website maintenance and uploading information
- Homepage and Social Media banner designs
- 44 Facebook Posts
- 22 School Messenger posts to MCHS families
- 75 Tweets and Re-Tweets

*Facebook terms: (Reach) Number of people who had any posts from our page enter their screen. (Post Engagement) Number of times people have engaged with our posts through likes, comments, shares, and more. (Video) Number of times our videos were played for at least 3 seconds.

**Twitter terms: (Impressions) Number of times users saw the tweet.

***MCHS.net (Unique Pageviews) Unique Pageviews is the number of sessions during which the specified page was viewed at least once.

Invoice Listing

COUNTY OF GRUNDY SCHOOL DIST 111

Full Name	PO Number	Invoice Number	Batch	Description	Invoice Date	Check Number	Net Amount
Grand Ball Costumes	1042100026	3/24/21 Musical	KAS	Musical Costume Rental	03/24/2021	026426	4,863.30
				<i>Musical Costume Rental</i>			<i>4,863.30</i>
				<i>10 E 1500 3000 70 300 000000</i>			<i>4,863.30</i>
Grand Ball Costumes			4,863.30				
Jesse White, Secretary		N 7173-099-9 2021	KAS	N 7173-099-9 Annual Report - District #111 Foundation for Educational Excellence	03/23/2021	026427	10.00
				<i>N 7173-099-9 Annual Report - District</i>			<i>10.00</i>
				<i>10 E 2310 4100 00 300 000000</i>			<i>10.00</i>
Jesse White, Secretary of			10.00				
				50			
Total Number of Batch Invoices:				0	\$0.00		
Total Number of Open Invoices:				0	\$0.00		
Total Number of History Invoices:				2	\$4,873.30		
Total Number of Update in Progress Batch Invoices:				0	\$0.00		
Total Number of Update in Progress Batch Reversal Invoices:				0	\$0.00		
Total Number of Reversal History Invoices:				0	\$0.00		
Total Number of Deleted History Invoices:				0	\$0.00		
Total Number of Batch Reversal Invoices:				0	\$0.00		
Total Number of Unsubmitted Invoices:				0	\$0.00		
Total Number of Awaiting for Approval Invoices:				0	\$0.00		
Total Invoices:				2	4,873.30		

Invoice Listing

COUNTY OF GRUNDY SCHOOL DIST 111

Full Name	PO Number	Invoice Number	Batch	Description	Invoice Date	Check Number	Net Amount
BMO Harris		4491 4/5/21	KAS	P-Card Purchases March 2021	04/05/2021	8200000009	9,888.91
				<i>2665 Jewel - Water for Safety Meeting</i>			10.10
				<i>2665 Dunkin Donuts - Donuts for Safety</i>			110.42
				<i>2110 Project Lead the Way - Vex</i>			989.00
				<i>2110 Amazon - Champion Sports</i>			72.71
				<i>2110 Quickbooks - Activity/Athletic</i>			40.00
				<i>2110 Quickbooks - Insurance</i>			40.00
				<i>2110 Quickbooks - Coady Scholarship</i>			40.00
				<i>2110 Illinois High School - Journalism</i>			100.00
				<i>2110 Zoom Monthly</i>			358.98
				<i>2110 Safetysign.com - Signs for Posting</i>			807.04
				<i>2110 Fat Boys Pizza - Maint/Custodial</i>			80.42
				<i>2110 Fat Boys Pizza - Maint/Custodial</i>			10.36
				<i>2110 Fat Boys Pizza - Maint/Custodial</i>			111.89
				<i>2110 SP Gilder Lehrman - Historical</i>			61.97
				<i>9180 Jewel - Water</i>			72.72
				<i>9180 Education Week Subscription</i>			79.00
				<i>9180 Amazon - Index Cards</i>			10.05
				<i>9180 Amazon - Address Labels</i>			20.11

51

Invoice Listing

COUNTY OF GRUNDY SCHOOL DIST 111

Full Name	PO Number	Invoice Number	Batch	Description	Invoice Date	Check Number	Net Amount
				9180 Giordanos - Math Luncheon			175.30
				9180 Sweetwater - Microphones			468.00
				9180 Amazon - Beer Bottle Prop			89.01
				9180 Baudville Inc. - Certificate Paper			68.93
				9180 Amazon - American Flag			26.99
				9180 Paper Direct - Certificate Folio			117.95
				9180 NASSP - NHS Tassels			378.00
				2053 Amazon - Inflatable Movie Screen			939.99
				2053 Amazon - Batteries			21.39
				2053 Amazon - FM Transmitter			88.98
				2053 Amazon - Table Covers			47.97
				2053 Amazon - Batteries			20.53
				2053 Amazon - Audio De-embedder			75.69
				2053 Dunkin Donuts - E-gift Cards			10.00
				2053 Sweetwater - Musical Supplies			46.67
				2053 Amazon - American Flags			112.88
				2053 Amazon - Bird Landyards			469.92
				2053 Amazon - Childrens Theatre			39.95
				2053 Sq Square Weebly - Student			144.00

Invoice Listing

COUNTY OF GRUNDY SCHOOL DIST 111

Full Name	PO Number	Invoice Number	Batch	Description	Invoice Date	Check Number	Net Amount	
				2053 Wristbandexpress.com - Tyvek			79.80	
				2053 Amazon - Refund Bird Landyards			-234.96	
				2053 Amazon - Refund Bird Landyards			-234.96	
				2053 Playbillonline - Musical			53.12	
				2053 Playbillonline - Musical			70.00	
				2053 Campus Supply - Student Activity			249.00	
				2053 Amazon - Prom Table Covers			17.99	
				2053 Amazon - Prom Table Covers			399.00	
				2053 Amazon - Prom Table Covers			161.49	53
				2053 Amazon - Prom Table Covers			17.99	
				2053 Amazon - Prom Supplies			391.30	
				2053 Amazon - Prom Table Covers,			508.86	
				2053 OTC Brands - Prom Decorations			992.41	
				2053 Amazon - Refund American Flags			-112.88	
				2053 TCT Andersons - Prom Masks,			620.24	
				0208 Hinckley Springs Water			100.17	
				02085 Amazon - Label Maker, Labels,			188.03	
				0208 Giordano's - Social Worker			65.45	
				0208 Amazon - Laminating Pouches,			59.95	

Invoice Listing

COUNTY OF GRUNDY SCHOOL DIST 111

Full Name	PO Number	Invoice Number	Batch	Description	Invoice Date	Check Number	Net Amount
				0208 Amazon - Bookcase			139.99
				40 E 2552 4100 00 300 000000			10.10
				40 E 2552 4100 00 300 000000			110.42
				10 E 1400 4100 10 300 000001			989.00
				10 E 1500 4100 30 300 000036			72.71
				10 E 2225 3000 00 300 000000			40.00
				10 E 2225 3000 00 300 000000			40.00
				10 E 2225 3000 00 300 000000			40.00
				10 E 1500 6400 70 300 000007			100.00
				10 E 2225 4700 00 300 000000			358.98
				20 E 2542 5300 00 302 000001			807.04
				40 E 2552 4100 00 300 000001			80.42
				40 E 2552 4100 00 300 000001			10.36
				40 E 2552 4100 00 300 000001			111.89
				10 E 1130 4100 15 300 000000			61.97
				10 E 2310 4100 00 300 000000			72.72
				10 E 2410 6400 00 300 000000			79.00
				10 E 2410 4100 00 300 000001			10.05
				10 E 2410 4100 00 300 000001			20.11
				10 E 2410 4100 00 300 000001			175.30
				10 E 1500 4100 70 300 000004			468.00

54

Invoice Listing

COUNTY OF GRUNDY SCHOOL DIST 111

Full Name	PO Number	Invoice Number	Batch	Description	Invoice Date	Check Number	Net Amount
				10 E 1500 4100 70 300 000004			89.01
				10 E 2410 4100 00 300 000001			68.93
				20 E 2540 4100 00 300 000000			26.99
				10 E 2410 4100 00 300 000001			117.95
				10 E 1500 4100 70 300 000003			378.00
				10 E 1500 3000 70 300 000000			939.99
				10 E 1500 4100 70 300 000004			21.39
				10 E 1500 4100 70 300 000004			88.98
				10 E 1500 4100 70 300 000021			47.97
				10 E 1500 4100 70 300 000004			20.53
				10 E 1500 4100 70 300 000004			75.69
				10 E 1500 4100 70 300 000021			10.00
				10 E 1500 4100 70 300 000004			46.67
				10 E 1500 4100 70 300 000021			112.88
				10 E 1500 4100 70 300 000021			469.92
				10 E 1500 4100 70 300 000008			39.95
				10 E 1500 3000 70 300 000002			144.00
				10 E 1500 4100 70 300 000021			79.80
				10 E 1500 4100 70 300 000021			-234.96
				10 E 1500 4100 70 300 000021			-234.96
				10 E 1500 3000 70 300 000000			53.12

55

Invoice Listing

COUNTY OF GRUNDY SCHOOL DIST 111

Full Name	PO Number	Invoice Number	Batch	Description	Invoice Date	Check Number	Net Amount
				10 E 1500 3000 70 300 000000			70.00
				10 E 1500 3320 70 300 000000			249.00
				10 E 1500 4100 70 300 000021			17.99
				10 E 1500 4100 70 300 000021			399.00
				10 E 1500 4100 70 300 000021			161.49
				10 E 1500 4100 70 300 000021			17.99
				10 E 1500 4100 70 300 000021			391.30
				10 E 1500 4100 70 300 000021			508.86
				10 E 1500 4100 70 300 000021			992.41
				10 E 1500 4100 70 300 000021			-112.88
				10 E 1500 4100 70 300 000021			620.24
				10 E 2134 3000 00 300 000000			100.17
				10 E 2100 4000 00 302 000000			188.03
				10 E 2100 4000 00 302 000000			65.45
				10 E 1200 4100 00 300 000002			59.95
				10 E 1200 4100 00 300 000002			139.99
	BMO Harris						9,888.91

56

Invoice Listing

COUNTY OF GRUNDY SCHOOL DIST 111

Full Name	PO Number	Invoice Number	Batch	Description	Invoice Date	Check Number	Net Amount
Total Number of Batch Invoices:			0				\$0.00
Total Number of Open Invoices:			0				\$0.00
Total Number of History Invoices:			1				\$9,888.91
Total Number of Update in Progress Batch Invoices:			0				\$0.00
Total Number of Update in Progress Batch Reversal Invoices:			0				\$0.00
Total Number of Reversal History Invoices:			0				\$0.00
Total Number of Deleted History Invoices:			0				\$0.00
Total Number of Batch Reversal Invoices:			0				\$0.00
Total Number of Unsubmitted Invoices:			0				\$0.00
Total Number of Awaiting for Approval Invoices:			0				\$0.00
Total Invoices:			1				9,888.91

Invoice Listing

COUNTY OF GRUNDY SCHOOL DIST 111

Full Name	PO Number	Invoice Number	Batch	Description	Invoice Date	Check Number	Net Amount
Blue Cross Blue Shield		550747984930	KAS	Minooka Community High School District 111, IL 1-015160, 5507466927, 3/1 - 3/31/21 Medical and Dental Insurance	03/31/2021		364,573.03
				<i>IL 1-015160, 5507466927, 3/1 - 3/31/21</i>		314,561.64	
				<i>IL 1-015160, 5507466927, 3/1 - 3/31/21</i>		6,012.21	
				<i>IL 1-015160, 5507466927, 3/1 - 3/31/21</i>		1,380.87	
				<i>IL 1-015160, 5507466927, 3/1 - 3/31/21</i>		24,984.14	
				<i>IL 1-015160, 5507466927, 3/1 - 3/31/21</i>		16,612.94	
				<i>IL 1-015160, 5507466927, 3/1 - 3/31/21</i>		809.15	
				<i>IL 1-015160, 5507466927, 3/1 - 3/31/21</i>		20.59	
				<i>IL 1-015160, 5507466927, 3/1 - 3/31/21</i>		191.49	58
				<i>10 E 1130 2220 00 000 000000</i>		314,561.64	
				<i>20 E 1130 2220 00 000 000000</i>		6,012.21	
				<i>40 E 1130 2220 00 000 000000</i>		1,380.87	
				<i>80 E 1130 2220 00 000 000000</i>		24,984.14	
				<i>10 E 1130 2230 00 000 000000</i>		16,612.94	
				<i>20 E 1130 2230 00 000 000000</i>		809.15	
				<i>40 E 1130 2230 00 000 000000</i>		20.59	
				<i>80 E 1130 2230 00 000 000000</i>		191.49	
Blue Cross Blue Shield of IL -			364,573.03				

Invoice Listing

COUNTY OF GRUNDY SCHOOL DIST 111

Full Name	PO Number	Invoice Number	Batch	Description	Invoice Date	Check Number	Net Amount
Total Number of Batch Invoices:			0				\$0.00
Total Number of Open Invoices:			0				\$0.00
Total Number of History Invoices:			1				\$364,573.03
Total Number of Update in Progress Batch Invoices:			0				\$0.00
Total Number of Update in Progress Batch Reversal Invoices:			0				\$0.00
Total Number of Reversal History Invoices:			0				\$0.00
Total Number of Deleted History Invoices:			0				\$0.00
Total Number of Batch Reversal Invoices:			0				\$0.00
Total Number of Unsubmitted Invoices:			0				\$0.00
Total Number of Awaiting for Approval Invoices:			0				\$0.00
Total Invoices:			1				364,573.03

Invoice Listing

COUNTY OF GRUNDY SCHOOL DIST 111

Full Name	PO Number	Invoice Number	Batch	Description	Invoice Date	Check Number	Net Amount
Blue Arrow Motors	0002100050	616	KAS	2011 Chevrolet Silverado WT, 1500 Work Trl, Silver Metallic, Vin: 1GCNCPE04BZ319222	03/23/2021	082188	13,376.00
				<i>2011 Chevrolet Silverado WT, 1500</i>			<i>13,376.00</i>
				<i>20 E 2540 5400 00 302 000000</i>			<i>13,376.00</i>
Blue Arrow Motors			13,376.00				
Total Number of Batch Invoices:				0			\$0.00
Total Number of Open Invoices:				0			\$0.00
Total Number of History Invoices:				1			\$13,376.00
Total Number of Update in Progress Batch Invoices:				0			\$0.00
Total Number of Update in Progress Batch Reversal Invoices:				0			\$0.00
Total Number of Reversal History Invoices:				0			\$0.00
Total Number of Deleted History Invoices:				0			\$0.00
Total Number of Batch Reversal Invoices:				0			\$0.00
Total Number of Unsubmitted Invoices:				0			\$0.00
Total Number of Awaiting for Approval Invoices:				0			\$0.00
Total Invoices:				1			13,376.00

Invoice Listing

COUNTY OF GRUNDY SCHOOL DIST 111

Full Name	PO Number	Invoice Number	Batch	Description	Invoice Date	Check Number	Net Amount
A Beep		100841	KAS	Antennas, Cords, Fuses for Buses	03/26/2021	082194	630.60
				<i>Antennas, Cords, Fuses for Buses</i>			630.60
				<i>40 E 2554 3230 00 300 000000</i>			630.60
A Beep			630.60				
A&M Products	1042100028	67892	KAS	Speech Ribbons	04/15/2021	082344	31.00
				<i>Speech Ribbons</i>			31.00
				<i>10 E 1500 4100 70 300 000001</i>			31.00
A&M Products			31.00				
ABM		1096290	KAS	Custodial Services for April 2021	04/01/2021	082195	52,059.83
				<i>Custodial Services for April 2021</i>			52,059.83
				<i>20 E 2540 3900 00 302 000001</i>			52,059.83
ABM			52,059.83				
ACDC Leadership	1012100091	0001683	KAS	Professional Development Workshop for AP Economics	04/06/2021	082196	590.00
				<i>AP Econ Conference Attendance</i>			590.00
				<i>10 E 2210 3000 15 300 000000</i>			590.00
ACDC Leadership			590.00				

Invoice Listing

COUNTY OF GRUNDY SCHOOL DIST 111

Full Name	PO Number	Invoice Number	Batch	Description	Invoice Date	Check Number	Net Amount
Alarm Detection		43740-1085	KAS	Quarterly Charges - Feb-Apr 2021	01/10/2021	9100000329	3,773.97
				<i>Quarterly Charges - Feb-Apr 2021</i>			3,773.97
				<i>80 E 2365 3900 00 300 000002</i>			3,773.97
Alarm Detection		SI-539580	KAS	Install Camera	12/08/2020	9100000329	1,995.49
				<i>Install Camera</i>			1,995.49
				<i>80 E 2546 5400 00 300 000000</i>			1,995.49
Alarm Detection		SI-545286	KAS	Replace existing Fire Alarm Panel and Pipe	03/12/2021	9100000329	1,853.41
				<i>Replace existing Fire Alarm Panel and</i>			62
				<i>80 E 2365 3900 00 300 000002</i>			1,853.41
Alarm Detection Systems Inc			7,622.87				

Invoice Listing

COUNTY OF GRUNDY SCHOOL DIST 111

Full Name	PO Number	Invoice Number	Batch	Description	Invoice Date	Check Number	Net Amount
Albertsons / Safeway		185499 4/3/21	KAS	Groceries 3/12, 3/19, 3/26, Water 3/23/21	04/03/2021	082197	519.99
				<i>Groceries 3/12/21</i>			43.86
				<i>Groceries 3/19/21</i>			52.36
				<i>Groceries 3/19/21</i>			303.48
				<i>Water 3/23/21</i>			31.68
				<i>Groceries 3/26/21</i>			88.61
				<i>10 E 1420 4100 09 300 000000</i>			43.86
				<i>10 E 1420 4100 09 300 000000</i>			52.36
				<i>10 E 1420 4100 09 300 000000</i>			303.48
				<i>10 E 2310 4100 00 300 000000</i>			31.68
				<i>10 E 1420 4100 09 300 000000</i>			88.61
Albertsons / Safeway		185500 4/3/21	KAS	Groceries 3/15, 3/22/21	04/03/2021	082197	110.77
				<i>Groceries 3/15/21</i>			85.90
				<i>Groceries 3/22/21</i>			24.87
				<i>10 E 1420 4100 09 300 000000</i>			85.90
				<i>10 E 1420 4100 09 300 000000</i>			24.87
Albertsons / Safeway			630.76				

Invoice Listing

COUNTY OF GRUNDY SCHOOL DIST 111

Full Name	PO Number	Invoice Number	Batch	Description	Invoice Date	Check Number	Net Amount
Alexander, John	1032100206	31886 4/13/21	KAS	Official-Baseball-4-13-21	04/13/2021	082345	65.00
				<i>Official-Baseball-4-13-21</i>			65.00
				<i>10 E 1500 3190 30 300 000007</i>			65.00
Alexander, John	1032100220	31886 4/15/21	KAS	Official-SO BB-4/15/21	04/15/2021	082345	56.00
				<i>Official-SO BB-4/15/21</i>			56.00
				<i>10 E 1500 3190 30 300 000007</i>			56.00
Alexander, John			121.00				
Amazon Capital		1NJR-9VM4-NMQV	KAS	A People and a Nation: A History of the United States, 8th Edition	03/11/2021	9100000330	-12.18
				<i>A People and a Nation: A History of the</i>			-12.18
				<i>10 E 1130 4200 15 300 000000</i>			-12.18
Amazon Capital	1012100079	1NJR-9VM4-NMQV 1	KAS	JJC US 103 and 104	03/16/2021	9100000330	12.95
				<i>A People and a Nation: A History of the</i>			12.95
				<i>10 E 1130 4200 15 300 000000</i>			12.95
Amazon Capital	1012100079	1NJR-9VM4-NMQV 2	KAS	JJC US 103 and 104	03/16/2021	9100000330	12.13
				<i>A People and a Nation: A History of the</i>			12.13
				<i>10 E 1130 4200 15 300 000000</i>			12.13

Invoice Listing

COUNTY OF GRUNDY SCHOOL DIST 111

Full Name	PO Number	Invoice Number	Batch	Description	Invoice Date	Check Number	Net Amount
Amazon Capital	1012100079	1NJR-9VM4-NMQV 3	KAS	JJC US 103 and 104	03/16/2021	9100000330	8.19
				<i>A People and a Nation: A History of the</i>			8.19
				<i>10 E 1130 4200 15 300 000000</i>			8.19
Amazon Capital	1012100079	1NJR-9VM4-NMQV 48	KAS	JJC US 103 and 104	03/16/2021	9100000330	54.44
				<i>A People and a Nation: A History of the</i>			54.44
				<i>10 E 1130 4200 15 300 000000</i>			54.44
Amazon Capital	1012100079	1NJR-9VM4-NMQV 52	KAS	JJC US 103 and 104	03/16/2021	9100000330	3.99
				<i>Cost of shipping, not including shipping</i>			3.99
				<i>10 E 1130 4200 15 300 000000</i>			3.99
Amazon Capital	1012100082	1NJR-9VM4-NMQV 10	KAS	Maker Space Supplies for Library	03/16/2021	9100000330	5.99
				<i>AIEX 10 PACK Clear Plastic Ruler 15cm</i>			5.99
				<i>10 E 2222 4100 00 300 000000</i>			5.99
Amazon Capital	1012100082	1NJR-9VM4-NMQV 11	KAS	Maker Space Supplies for Library	03/16/2021	9100000330	19.96
				<i>Diecuts with a View 12 inches by 12</i>			19.96
				<i>10 E 2222 4100 00 300 000000</i>			19.96

Invoice Listing

COUNTY OF GRUNDY SCHOOL DIST 111

Full Name	PO Number	Invoice Number	Batch	Description	Invoice Date	Check Number	Net Amount
Amazon Capital	1012100082	1NJR-9VM4-NMQV 12	KAS	Maker Space Supplies for Library	03/16/2021	9100000330	14.99
				<i>Scotch Double Sided Tape, 3/4 in x 1296</i>			14.99
				<i>10 E 2222 4100 00 300 000000</i>			14.99
Amazon Capital	1012100082	1NJR-9VM4-NMQV 13	KAS	Maker Space Supplies for Library	03/16/2021	9100000330	7.44
				<i>Mod Podge CS11302 Waterbase Sealer,</i>			7.44
				<i>10 E 2222 4100 00 300 000000</i>			7.44
Amazon Capital	1012100082	1NJR-9VM4-NMQV 14	KAS	Maker Space Supplies for Library	03/16/2021	9100000330	11.49
				<i>Roots Circle All-Natural Citric Acid </i>			11.49
				<i>10 E 2222 4100 00 300 000000</i>			11.49
Amazon Capital	1012100082	1NJR-9VM4-NMQV 15	KAS	Maker Space Supplies for Library	03/16/2021	9100000330	21.99
				<i>Amazon Basics Clear Thermal</i>			21.99
				<i>10 E 2222 4100 00 300 000000</i>			21.99
Amazon Capital	1012100082	1NJR-9VM4-NMQV 16	KAS	Maker Space Supplies for Library	03/16/2021	9100000330	47.12
				<i>Oxford Ruled Index Cards, 3" x 5",</i>			47.12
				<i>10 E 2222 4100 00 300 000000</i>			47.12

Invoice Listing

COUNTY OF GRUNDY SCHOOL DIST 111

Full Name	PO Number	Invoice Number	Batch	Description	Invoice Date	Check Number	Net Amount
Amazon Capital	1012100082	1NJR-9VM4-NMQV 17	KAS	Maker Space Supplies for Library	03/16/2021	9100000330	19.81
				<i>Scotch Double Sided Tape with Deluxe</i>			19.81
				<i>10 E 2222 4100 00 300 000000</i>			19.81
Amazon Capital	1012100082	1NJR-9VM4-NMQV 18	KAS	Maker Space Supplies for Library	03/16/2021	9100000330	17.57
				<i>Officemate 2-in-1 Heavy Duty Tape</i>			17.57
				<i>10 E 2222 4100 00 300 000000</i>			17.57
Amazon Capital	1012100082	1NJR-9VM4-NMQV 19	KAS	Maker Space Supplies for Library	03/16/2021	9100000330	6.98
				<i>Crayola Construction Paper, Assorted</i>			6.98
				<i>10 E 2222 4100 00 300 000000</i>			6.98
Amazon Capital	1012100082	1NJR-9VM4-NMQV 20	KAS	Maker Space Supplies for Library	03/16/2021	9100000330	11.90
				<i>Desktop Tape Dispenser Adhesive Roll</i>			11.90
				<i>10 E 2222 4100 00 300 000000</i>			11.90
Amazon Capital	1012100082	1NJR-9VM4-NMQV 21	KAS	Maker Space Supplies for Library	03/16/2021	9100000330	14.99
				<i>SunWorks Construction Paper, 10</i>			14.99
				<i>10 E 2222 4100 00 300 000000</i>			14.99

Invoice Listing

COUNTY OF GRUNDY SCHOOL DIST 111

Full Name	PO Number	Invoice Number	Batch	Description	Invoice Date	Check Number	Net Amount
Amazon Capital	1012100082	1NJR-9VM4-NMQV 22	KAS	Maker Space Supplies for Library	03/16/2021	9100000330	10.99
				<i>Glue Dots Project Pack, 200 (.375")</i>			10.99
				<i>10 E 2222 4100 00 300 000000</i>			10.99
Amazon Capital	1012100082	1NJR-9VM4-NMQV 24	KAS	Maker Space Supplies for Library	03/16/2021	9100000330	11.99
				<i>9 Inch H-Band Silicone Rubber Bands</i>			11.99
				<i>10 E 2222 4100 00 300 000000</i>			11.99
Amazon Capital	1012100082	1NJR-9VM4-NMQV 25	KAS	Maker Space Supplies for Library	03/16/2021	9100000330	6.98
				<i>Arm & Hammer Pure Baking Soda</i>			6.98
				<i>10 E 2222 4100 00 300 000000</i>			6.98
Amazon Capital	1012100082	1NJR-9VM4-NMQV 26	KAS	Maker Space Supplies for Library	03/16/2021	9100000330	11.99
				<i>Aoibrloy 5 x 7 Inch Wooden Paper</i>			11.99
				<i>10 E 2222 4100 00 300 000000</i>			11.99
Amazon Capital	1012100082	1NJR-9VM4-NMQV 27	KAS	Maker Space Supplies for Library	03/16/2021	9100000330	22.00
				<i>excell EX-17/3IN JVCC EX-17 Steel</i>			22.00
				<i>10 E 2222 4100 00 300 000000</i>			22.00

Invoice Listing

COUNTY OF GRUNDY SCHOOL DIST 111

Full Name	PO Number	Invoice Number	Batch	Description	Invoice Date	Check Number	Net Amount
Amazon Capital	1012100082	1NJR-9VM4-NMQV 28	KAS	Maker Space Supplies for Library	03/16/2021	9100000330	17.19
				<i>Elmer Super Slime Bundle - Glow-in-</i>			17.19
				<i>10 E 2222 4100 00 300 000000</i>			17.19
Amazon Capital	1012100082	1NJR-9VM4-NMQV 29	KAS	Maker Space Supplies for Library	03/16/2021	9100000330	9.99
				<i>24 PCS Silicone Rubber Bands Planner</i>			9.99
				<i>10 E 2222 4100 00 300 000000</i>			9.99
Amazon Capital	1012100082	1NJR-9VM4-NMQV 30	KAS	Maker Space Supplies for Library	03/16/2021	9100000330	9.99
				<i>Aluminum Pans 9x13 Disposable Foil</i>			9.99
				<i>10 E 2222 4100 00 300 000000</i>			9.99
Amazon Capital	1012100082	1NJR-9VM4-NMQV 31	KAS	Maker Space Supplies for Library	03/16/2021	9100000330	7.99
				<i>Epsoak Epsom Salt - 2 lbs. USP</i>			7.99
				<i>10 E 2222 4100 00 300 000000</i>			7.99
Amazon Capital	1012100082	1NJR-9VM4-NMQV 32	KAS	Maker Space Supplies for Library	03/16/2021	9100000330	6.99
				<i>Double Sided Tape 2 Pack Heavy Duty -</i>			6.99
				<i>10 E 2222 4100 00 300 000000</i>			6.99

Invoice Listing

COUNTY OF GRUNDY SCHOOL DIST 111

Full Name	PO Number	Invoice Number	Batch	Description	Invoice Date	Check Number	Net Amount
Amazon Capital	1012100082	1NJR-9VM4-NMQV 33	KAS	Maker Space Supplies for Library	03/16/2021	9100000330	5.88
				<i>ColorBok 71876B Cardstock Paper Pad</i>			5.88
				<i>10 E 2222 4100 00 300 000000</i>			5.88
Amazon Capital	1012100082	1NJR-9VM4-NMQV 34	KAS	Maker Space Supplies for Library	03/16/2021	9100000330	6.58
				<i>NOW Solutions, Sweet Almond Oil,</i>			6.58
				<i>10 E 2222 4100 00 300 000000</i>			6.58
Amazon Capital	1012100082	1NJR-9VM4-NMQV 35	KAS	Maker Space Supplies for Library	03/16/2021	9100000330	223.15
				<i>Bankers Box STOR/File Storage Boxes,</i>			70
				<i>10 E 2222 4100 00 300 000000</i>			223.15
Amazon Capital	1012100082	1NJR-9VM4-NMQV 4	KAS	Maker Space Supplies for Library	03/16/2021	9100000330	14.64
				<i>Amazon Basics Liquid Washable Glitter</i>			14.64
				<i>10 E 2222 4100 00 300 000000</i>			14.64
Amazon Capital	1012100082	1NJR-9VM4-NMQV 5	KAS	Maker Space Supplies for Library	03/16/2021	9100000330	9.49
				<i>Bloss [8 Pieces] Bath Bomb Mold,DIY</i>			9.49
				<i>10 E 2222 4100 00 300 000000</i>			9.49

Invoice Listing

COUNTY OF GRUNDY SCHOOL DIST 111

Full Name	PO Number	Invoice Number	Batch	Description	Invoice Date	Check Number	Net Amount
Amazon Capital	1012100082	1NJR-9VM4-NMQV 6	KAS	Maker Space Supplies for Library	03/16/2021	9100000330	13.98
				<i>Fabric Markers Pen, 32 Colors</i>			13.98
				<i>10 E 2222 4100 00 300 000000</i>			13.98
Amazon Capital	1012100082	1NJR-9VM4-NMQV 7	KAS	Maker Space Supplies for Library	03/16/2021	9100000330	34.29
				<i>Numbers 1-5 Bulk Pack Office</i>			34.29
				<i>10 E 2222 4100 00 300 000000</i>			34.29
Amazon Capital	1012100082	1NJR-9VM4-NMQV 8	KAS	Maker Space Supplies for Library	03/16/2021	9100000330	9.79
				<i>White Circle with Black Number 6</i>			9.79
				<i>10 E 2222 4100 00 300 000000</i>			9.79
Amazon Capital	1012100082	1NJR-9VM4-NMQV 9	KAS	Maker Space Supplies for Library	03/16/2021	9100000330	6.98
				<i>365pcs Jewels StickersGem Stickers</i>			6.98
				<i>10 E 2222 4100 00 300 000000</i>			6.98
Amazon Capital	1012100083	1NJR-9VM4-NMQV 36	KAS	Maker Space supplies for Library Student as creator based activities	03/16/2021	9100000330	9.99
				<i>Elmer's Disappearing Purple School</i>			9.99
				<i>10 E 2222 4100 00 300 000000</i>			9.99

Invoice Listing

COUNTY OF GRUNDY SCHOOL DIST 111

Full Name	PO Number	Invoice Number	Batch	Description	Invoice Date	Check Number	Net Amount
Amazon Capital	1012100083	1NJR-9VM4-NMQV 37	KAS	Maker Space supplies for Library Student as creator based activities	03/16/2021	9100000330	14.99
				<i>SunWorks Construction Paper, 10</i>			14.99
				<i>10 E 2222 4100 00 300 000000</i>			14.99
Amazon Capital	1012100083	1NJR-9VM4-NMQV 38	KAS	Maker Space supplies for Library Student as creator based activities	03/16/2021	9100000330	5.88
				<i>ColorBok 71876B Cardstock Paper Pad</i>			5.88
				<i>10 E 2222 4100 00 300 000000</i>			5.88
Amazon Capital	1012100083	1NJR-9VM4-NMQV 39	KAS	Maker Space supplies for Library Student as creator based activities	03/16/2021	9100000330	14.99
							72
				<i>Scotch Double Sided Tape, 3/4 in x 1296</i>			14.99
				<i>10 E 2222 4100 00 300 000000</i>			14.99
Amazon Capital	1012100083	1NJR-9VM4-NMQV 40	KAS	Maker Space supplies for Library Student as creator based activities	03/16/2021	9100000330	19.81
				<i>Scotch Double Sided Tape with Deluxe</i>			19.81
				<i>10 E 2222 4100 00 300 000000</i>			19.81
Amazon Capital	1012100083	1NJR-9VM4-NMQV 41	KAS	Maker Space supplies for Library Student as creator based activities	03/16/2021	9100000330	10.99
				<i>Glue Dots Project Pack, 200 (.375")</i>			10.99
				<i>10 E 2222 4100 00 300 000000</i>			10.99

Invoice Listing

COUNTY OF GRUNDY SCHOOL DIST 111

Full Name	PO Number	Invoice Number	Batch	Description	Invoice Date	Check Number	Net Amount
Amazon Capital	1012100083	1NJR-9VM4-NMQV 42	KAS	Maker Space supplies for Library Student as creator based activities	03/16/2021	9100000330	6.99
				<i>Double Sided Tape 2 Pack Heavy Duty -</i>			6.99
				<i>10 E 2222 4100 00 300 000000</i>			6.99
Amazon Capital	1012100083	1NJR-9VM4-NMQV 43	KAS	Maker Space supplies for Library Student as creator based activities	03/16/2021	9100000330	17.57
				<i>Officemate 2-in-1 Heavy Duty Tape</i>			17.57
				<i>10 E 2222 4100 00 300 000000</i>			17.57
Amazon Capital	1012100083	1NJR-9VM4-NMQV 44	KAS	Maker Space supplies for Library Student as creator based activities	03/16/2021	9100000330	3.49
				<i>Crayola Construction Paper, Assorted</i>			3.49
				<i>10 E 2222 4100 00 300 000000</i>			3.49
Amazon Capital	1012100083	1NJR-9VM4-NMQV 45	KAS	Maker Space supplies for Library Student as creator based activities	03/16/2021	9100000330	9.99
				<i>24 PCS Silicone Rubber Bands Planner</i>			9.99
				<i>10 E 2222 4100 00 300 000000</i>			9.99
Amazon Capital	1012100083	1NJR-9VM4-NMQV 46	KAS	Maker Space supplies for Library Student as creator based activities	05/04/2021	9100000330	19.96
				<i>Diecuts with a View 12 inches by 12</i>			19.96
				<i>10 E 2222 4100 00 300 000000</i>			19.96

Invoice Listing

COUNTY OF GRUNDY SCHOOL DIST 111

Full Name	PO Number	Invoice Number	Batch	Description	Invoice Date	Check Number	Net Amount
Amazon Capital	1012100083	1NJR-9VM4-NMQV 47	KAS	Maker Space supplies for Library Student as creator based activities	03/16/2021	9100000330	11.99
				<i>9 Inch H-Band Silicone Rubber Bands</i>			11.99
				<i>10 E 2222 4100 00 300 000000</i>			11.99
Amazon Capital	1012100093	1WJ3-4PKF-K9PF 1	KAS	Social Studies Teacher Supply Request	04/06/2021	9100000330	13.58
				<i>Cabepow iPhone Charger Cable, 3ft</i>			13.58
				<i>10 E 1130 4100 15 300 000000</i>			13.58
Amazon Capital	1012100093	1WJ3-4PKF-K9PF 2	KAS	Social Studies Teacher Supply Request	04/06/2021	9100000330	6.99
				<i>RCA Extension Cable - Gold Plated 3</i>			6.99
				<i>10 E 1130 4100 15 300 000000</i>			6.99
Amazon Capital	1012100093	1WJ3-4PKF-K9PF 5	KAS	Social Studies Teacher Supply Request	04/06/2021	9100000330	14.99
				<i>Storage Bag for USB Flash Drive JBOS</i>			14.99
				<i>10 E 1130 4100 15 300 000000</i>			14.99
Amazon Capital	1012100095	1WJ3-4PKF-K9PF 4	KAS	Social Studies Teacher Supply Request	04/06/2021	9100000330	35.98
				<i>Samsung FIT Plus USB 3.1 Flash Drive</i>			35.98
				<i>10 E 1130 4100 15 300 000000</i>			35.98

Invoice Listing

COUNTY OF GRUNDY SCHOOL DIST 111

Full Name	PO Number	Invoice Number	Batch	Description	Invoice Date	Check Number	Net Amount
Amazon Capital	1022100054	1LDV-WN3P-LPX9 1	KAS	Blank keystone plates for Press box.	03/30/2021	9100000330	34.76
				<i>Legrand - On-Q WP3455GY Blank</i>			34.76
				<i>10 E 2225 4100 00 300 000000</i>			34.76
Amazon Capital	1022100054	1NJR-9VM4-NMQV 49	KAS	Blank keystone plates for Press box.	03/16/2021	9100000330	17.99
				<i>TRENDnet Punch Down Tool with 110</i>			17.99
				<i>10 E 2225 4100 00 300 000000</i>			17.99
Amazon Capital	1022100056	1LDV-WN3P-LPX9 2	KAS	On field XLR Connector for on field sports (Cheerleading/POMS/Football/Soccer)	03/30/2021	9100000330	165.08
				<i>Rapco Horizon LTIBLOX Laptop</i>			165.08
				<i>10 E 2225 4100 00 300 000000</i>			165.08
Amazon Capital	1062100007	1NJR-9VM4-NMQV 50	KAS	Flags (4)	03/16/2021	9100000330	159.80
				<i>G128 - American USA US Flag 6x10 ft</i>			159.80
				<i>20 E 2540 4100 00 300 000000</i>			159.80
Amazon Capital	1062100007	1NJR-9VM4-NMQV 51	KAS	Flags (4)	03/16/2021	9100000330	16.95
				<i>G128 - American USA US Flag 3x5 ft</i>			16.95
				<i>20 E 2540 4100 00 300 000000</i>			16.95

Invoice Listing

COUNTY OF GRUNDY SCHOOL DIST 111

Full Name	PO Number	Invoice Number	Batch	Description	Invoice Date	Check Number	Net Amount
Amazon Capital	1092100029	1NJR-9VM4-NMQV 23	KAS	Replacement tools for wood shop	03/16/2021	9100000330	472.00
				<i>DEWALT Random Orbit Sander, 5-Inch</i>			472.00
				<i>10 E 1400 4100 10 300 000001</i>			472.00
Amazon Capital	1092100030	1LDV-WN3P-LPX9 3	KAS	Welding supplies	03/30/2021	9100000330	179.50
				<i>Channellock 440 Tongue and Groove</i>			179.50
				<i>10 E 1400 4100 10 300 000001</i>			179.50
Amazon Capital	1092100030	1LDV-WN3P-LPX9 4	KAS	Welding supplies	03/30/2021	9100000330	139.96
				<i>Industrial Argon Regulator/Flowmeter</i>			76
				<i>10 E 1400 4100 10 300 000001</i>			139.96
Amazon Capital	1092100032	1LDV-WN3P-LPX9 5	KAS	Welding Supply	03/30/2021	9100000330	89.42
				<i>Steiner 332-6X8 Arcview 14 Mil Flame</i>			89.42
				<i>10 E 1400 4100 10 300 000001</i>			89.42
Amazon Capital	1092100033	1LDV-WN3P-LPX9 12	KAS	Fashion and Sewing cricut supplies	03/30/2021	9100000330	20.48
				<i>Cricut Easy 12"x12" EasyPress,</i>			20.48
				<i>10 E 1420 4100 09 300 000000</i>			20.48

Invoice Listing

COUNTY OF GRUNDY SCHOOL DIST 111

Full Name	PO Number	Invoice Number	Batch	Description	Invoice Date	Check Number	Net Amount
Amazon Capital	1092100033	1LDV-WN3P-LPX9 13	KAS	Fashion and Sewing cricut supplies	03/30/2021	9100000330	14.34
				<i>Cricut 2006695 Tools Basic CORE</i>			14.34
				<i>10 E 1420 4100 09 300 000000</i>			14.34
Amazon Capital	1092100033	1LDV-WN3P-LPX9 14	KAS	Fashion and Sewing cricut supplies	03/30/2021	9100000330	29.68
				<i>HOMEST Lightweight Carrying Case</i>			29.68
				<i>10 E 1420 4100 09 300 000000</i>			29.68
Amazon Capital	1092100033	1LDV-WN3P-LPX9 15	KAS	Fashion and Sewing cricut supplies	03/30/2021	9100000330	25.96
							77
				<i>CAREGY Heat Transfer Vinyl HTV</i>			25.96
				<i>10 E 1420 4100 09 300 000000</i>			25.96
Amazon Capital	1092100033	1LDV-WN3P-LPX9 16	KAS	Fashion and Sewing cricut supplies	03/30/2021	9100000330	30.40
				<i>Cricut SCORING WHEEL COMBO</i>			30.40
				<i>10 E 1420 4100 09 300 000000</i>			30.40
Amazon Capital	1092100033	1LDV-WN3P-LPX9 17	KAS	Fashion and Sewing cricut supplies	03/30/2021	9100000330	24.99
				<i>Cricut Knife Housing & Blade, Original</i>			24.99
				<i>10 E 1420 4100 09 300 000000</i>			24.99

Invoice Listing

COUNTY OF GRUNDY SCHOOL DIST 111

Full Name	PO Number	Invoice Number	Batch	Description	Invoice Date	Check Number	Net Amount
Amazon Capital	1092100033	1LDV-WN3P-LPX9 18	KAS	Fashion and Sewing cricut supplies	03/30/2021	9100000330	20.47
				<i>Cricut Ultimate Fine Point Pen Set, 30</i>			20.47
				<i>10 E 1420 4100 09 300 000000</i>			20.47
Amazon Capital	1092100033	1LDV-WN3P-LPX9 19	KAS	Fashion and Sewing cricut supplies	03/30/2021	9100000330	14.48
				<i>Cricut Washable Fabric Pen, Blue, 5</i>			14.48
				<i>10 E 1420 4100 09 300 000000</i>			14.48
Amazon Capital	1092100033	1LDV-WN3P-LPX9 20	KAS	Fashion and Sewing cricut supplies	03/30/2021	9100000330	17.86
				<i>Klutz Sew Mini Animals Craft Kit</i>			17.86
				<i>10 E 1420 4100 09 300 000000</i>			17.86
Amazon Capital	1092100033	1LDV-WN3P-LPX9 21	KAS	Fashion and Sewing cricut supplies	03/30/2021	9100000330	11.85
				<i>Klutz Sew Mini Treats Craft Kit</i>			11.85
				<i>10 E 1420 4100 09 300 000000</i>			11.85
Amazon Capital	1092100033	1LDV-WN3P-LPX9 22	KAS	Fashion and Sewing cricut supplies	03/30/2021	9100000330	74.99
				<i>Cricut Easy Press Mini - Raspberry Heat</i>			74.99
				<i>10 E 1420 4100 09 300 000000</i>			74.99

Invoice Listing

COUNTY OF GRUNDY SCHOOL DIST 111

Full Name	PO Number	Invoice Number	Batch	Description	Invoice Date	Check Number	Net Amount
Amazon Capital	1112100002	1LDV-WN3P-LPX9 23	KAS	Dry erase markers for classrooms	03/30/2021	9100000330	179.84
				<i>Mobile Whiteboard - 48x36 Large Height</i>			179.84
				<i>10 E 1130 4100 11 300 000000</i>			179.84
Amazon Capital	1112100002	1LDV-WN3P-LPX9 6	KAS	Dry erase markers for classrooms	03/30/2021	9100000330	21.98
				<i>Amazon Basics 36 Pack AAA High-</i>			21.98
				<i>10 E 1130 4100 11 300 000000</i>			21.98
Amazon Capital	1112100002	1LDV-WN3P-LPX9 7	KAS	Dry erase markers for classrooms	03/30/2021	9100000330	430.20
				<i>Arteza Dry Erase Markers, Bulk Pack of</i>			430.20
				<i>10 E 1130 4100 11 300 000000</i>			430.20
Amazon Capital	1122100021	17F4-FHTM-KDDW 1	KAS	2 TV's & 2 Carts for instructional purposes.	03/23/2021	9100000330	325.96
				<i>Rolling/Mobile TV Cart with Wheels for</i>			325.96
				<i>10 E 1130 4100 50 300 000000</i>			325.96
Amazon Capital	1122100024	1LDV-WN3P-LPX9 24	KAS	2 TVs for Instructional Purposes	03/30/2021	9100000330	1,293.98
				<i>LG 65UN7300PUF Alexa Built-In UHD</i>			1,293.98
				<i>10 E 1130 4100 50 300 000000</i>			1,293.98

Invoice Listing

COUNTY OF GRUNDY SCHOOL DIST 111

Full Name	PO Number	Invoice Number	Batch	Description	Invoice Date	Check Number	Net Amount
Amazon Capital	1122100025	1LDV-WN3P-LPX9 25	KAS	Fitness Equipment for South Campus Teachers. SC Teachers received \$500 for doing a national tobacco survey and this is the fitness equipment they want to purchase with that money. <i>YUNMAI Yoga Block Set of 2 Foam</i>	03/30/2021	9100000330	9.99
				<i>10 E 1130 4100 50 300 000000</i>			9.99
Amazon Capital	1122100025	1LDV-WN3P-LPX9 35	KAS	Fitness Equipment for South Campus Teachers. SC Teachers received \$500 for doing a national tobacco survey and this is the fitness equipment they want to purchase with that money. <i>RitFit Set of Two Neoprene Dumbbells</i>	03/30/2021	9100000330	195.96
				<i>10 E 1130 4100 50 300 000000</i>			195.96
Amazon Capital	1122100025	1LDV-WN3P-LPX9 8	KAS	Fitness Equipment for South Campus Teachers. SC Teachers received \$500 for doing a national tobacco survey and this is the fitness equipment they want to purchase with that money. <i>Hello Fit Yoga Mats, Bulk 10 Pack,</i>	03/30/2021	9100000330	159.98
				<i>10 E 1130 4100 50 300 000000</i>			159.98
Amazon Capital	1132100008	1LDV-WN3P-LPX9 26	KAS	AP Physics Supplies <i>3B Scientific GmbH 1000598 Diffraction</i>	03/30/2021	9100000330	15.42
				<i>10 E 1130 4100 13 300 000000</i>			15.42

Invoice Listing

COUNTY OF GRUNDY SCHOOL DIST 111

Full Name	PO Number	Invoice Number	Batch	Description	Invoice Date	Check Number	Net Amount
Amazon Capital	1132100008	1LDV-WN3P-LPX9 27	KAS	AP Physics Supplies	03/30/2021	9100000330	22.19
				<i>Diaphragm with 4 Double Slits of</i>			22.19
				<i>10 E 1130 4100 13 300 000000</i>			22.19
Amazon Capital	1132100008	1WJ3-4PKF-K9PF 3	KAS	AP Physics Supplies	04/06/2021	9100000330	28.07
				<i>American 3B Scientific U14100</i>			28.07
				<i>10 E 1130 4100 13 300 000000</i>			28.07
Amazon Capital	1132100009	1LDV-WN3P-LPX9 28	KAS	Mousetrap cars for Classical Physics	03/30/2021	9100000330	99.90
				<i>TACKLIFE Mini Hot Glue Gun 20w with</i>			81
				<i>10 E 1130 4100 13 300 000000</i>			99.90
				<i>10 E 1130 4100 13 300 000000</i>			99.90
Amazon Capital	1132100009	1LDV-WN3P-LPX9 29	KAS	Mousetrap cars for Classical Physics	03/30/2021	9100000330	7.99
				<i>WP-TT 100pcs Plastic Roll 2mm Dia</i>			7.99
				<i>10 E 1130 4100 13 300 000000</i>			7.99
Amazon Capital	1132100009	1LDV-WN3P-LPX9 30	KAS	Mousetrap cars for Classical Physics	03/30/2021	9100000330	20.78
				<i>Perfect Stix - PS 12" CRAFT/ PAINT</i>			20.78
				<i>10 E 1130 4100 13 300 000000</i>			20.78

Invoice Listing

COUNTY OF GRUNDY SCHOOL DIST 111

Full Name	PO Number	Invoice Number	Batch	Description	Invoice Date	Check Number	Net Amount
Amazon Capital	1132100009	1LDV-WN3P-LPX9 31	KAS	Mousetrap cars for Classical Physics	03/30/2021	9100000330	30.99
				<i>Victor M156 Metal Pedal Mouse Trap –</i>			30.99
				<i>10 E 1130 4100 13 300 000000</i>			30.99
Amazon Capital	1132100009	1LDV-WN3P-LPX9 33	KAS	Mousetrap cars for Classical Physics	03/30/2021	9100000330	6.88
				<i>Lehigh Group NST1514HD Nylon Seine</i>			6.88
				<i>10 E 1130 4100 13 300 000000</i>			6.88
Amazon Capital	1132100010	1LDV-WN3P-LPX9 10	KAS	classical physics supplies	03/30/2021	9100000330	19.97
				<i>SHLA THE RIGHT CONNECTION</i>			19.97
				<i>10 E 1130 4100 13 300 000000</i>			19.97
Amazon Capital	1132100010	1LDV-WN3P-LPX9 11	KAS	classical physics supplies	03/30/2021	9100000330	23.97
				<i>WP-TT 100pcs Plastic Roll 2mm Dia</i>			23.97
				<i>10 E 1130 4100 13 300 000000</i>			23.97
Amazon Capital	1132100010	1LDV-WN3P-LPX9 34	KAS	classical physics supplies	03/30/2021	9100000330	13.76
				<i>Lehigh Group NST1514HD Nylon Seine</i>			13.76
				<i>10 E 1130 4100 13 300 000000</i>			13.76

Invoice Listing

COUNTY OF GRUNDY SCHOOL DIST 111

Full Name	PO Number	Invoice Number	Batch	Description	Invoice Date	Check Number	Net Amount
Amazon Capital	1132100010	1LDV-WN3P-LPX9 9	KAS	classical physics supplies	03/30/2021	9100000330	31.96
				<i>WP-TT 100pcs Plastic Roll 2mm Dia</i>			31.96
				<i>10 E 1130 4100 13 300 000000</i>			31.96
Amazon Capital	1132100011	1LDV-WN3P-LPX9 32	KAS	classical physics supplies	03/30/2021	9100000330	115.96
				<i>Victor M156 Metal Pedal Mouse Trap –</i>			115.96
				<i>10 E 1130 4100 13 300 000000</i>			115.96
Amazon Capital		1LDV-WN3P-LPX9	KAS	Credit - Mobile Whiteboard 48x36 (PO 1112100002)	04/13/2021	9100000357	-179.84
				<i>Credit - Mobile Whiteboard 48x36 (PO</i>			-179.84
				<i>10 E 1130 4100 11 300 000000</i>			-179.84
Amazon Capital	0002100051	1QTF-JYNV-MGG1 4	KAS	Roundup QuickPro Herbicide Packets - 30	04/13/2021	9100000357	77.95
				<i>Roundup QuikPro 1 case Net 30 (1.5oz)</i>			77.95
				<i>20 E 2540 3000 00 302 000001</i>			77.95
Amazon Capital	0002100052	1QTF-JYNV-MGG1 11	KAS	Disposable Face Masks	04/13/2021	9100000357	126.80
				<i>Disposable Face Mask, Face Masks of</i>			126.80
				<i>20 E 2540 4100 00 300 000000</i>			63.40
				<i>20 E 2540 4100 00 302 000000</i>			63.40

Invoice Listing

COUNTY OF GRUNDY SCHOOL DIST 111

Full Name	PO Number	Invoice Number	Batch	Description	Invoice Date	Check Number	Net Amount
Amazon Capital	1012100099	1QTF-JYNV-MGG1 12	KAS	AP Human Geography Additional textbooks	04/13/2021	9100000357	7.98
				<i>Cost of shipping, not including shipping</i>			7.98
				<i>10 E 1130 4200 15 300 000000</i>			7.98
Amazon Capital	1012100099	1QTF-JYNV-MGG1 5	KAS	AP Human Geography Additional textbooks	04/13/2021	9100000357	111.78
				<i>The Cultural Landscape: An Introduction</i>			111.78
				<i>10 E 1130 4200 15 300 000000</i>			111.78
Amazon Capital	1012100099	1QTF-JYNV-MGG1 6	KAS	AP Human Geography Additional textbooks	04/13/2021	9100000357	59.88
				<i>The Cultural Landscape: An Introduction</i>			59.88
				<i>10 E 1130 4200 15 300 000000</i>			59.88
Amazon Capital	1012100099	1QTF-JYNV-MGG1 7	KAS	AP Human Geography Additional textbooks	04/13/2021	9100000357	59.99
				<i>The Cultural Landscape: An Introduction</i>			59.99
				<i>10 E 1130 4200 15 300 000000</i>			59.99
Amazon Capital	1012100099	1QTF-JYNV-MGG1 8	KAS	AP Human Geography Additional textbooks	04/13/2021	9100000357	59.88
				<i>The Cultural Landscape: An Introduction</i>			59.88
				<i>10 E 1130 4200 15 300 000000</i>			59.88

Invoice Listing

COUNTY OF GRUNDY SCHOOL DIST 111

Full Name	PO Number	Invoice Number	Batch	Description	Invoice Date	Check Number	Net Amount
Amazon Capital	1012100099	1QTF-JYNV-MGG1 9	KAS	AP Human Geography Additional textbooks	04/13/2021	9100000357	64.58
				<i>The Cultural Landscape: An Introduction</i>			64.58
				<i>10 E 1130 4200 15 300 000000</i>			64.58
Amazon Capital	1022100057	1QTF-JYNV-MGG1 10	KAS	4 boxes of Cat6 patch cable for upcoming projects	04/13/2021	9100000357	239.96
				<i>Dripstone - 600003 CAT6 Solid UTP</i>			239.96
				<i>10 E 2225 4100 00 300 000000</i>			239.96
Amazon Capital	1022100058	1QTF-JYNV-MGG1 1	KAS	XLR Adapters	04/13/2021	9100000357	163.32
							85
				<i>Rapco Horizon LTIBLOX Laptop</i>			163.32
				<i>10 E 2225 4100 00 300 000000</i>			163.32
Amazon Capital	1022100059	1QTF-JYNV-MGG1 2	KAS	XLR Cables and Bluetooth Headset for Dr. Lee.	04/13/2021	9100000357	41.97
				<i>Amazon Basics XLR Male to Female</i>			41.97
				<i>10 E 2225 4100 00 300 000000</i>			41.97
Amazon Capital	1022100059	1QTF-JYNV-MGG1 3	KAS	XLR Cables and Bluetooth Headset for Dr. Lee.	04/13/2021	9100000357	35.99
				<i>Bluetooth Headset 5.0 with CVC8.0 Dual</i>			35.99
				<i>10 E 2225 4100 00 300 000000</i>			35.99
Amazon Capital Services, Inc.			6,425.74				

Invoice Listing

COUNTY OF GRUNDY SCHOOL DIST 111

Full Name	PO Number	Invoice Number	Batch	Description	Invoice Date	Check Number	Net Amount
American Muscle Docks	1122100026	3251052	KAS	Floats for new deck at the pond.	03/25/2021	082346	1,105.00
				<i>Float 2x4x12 Flanged UPS</i>			<i>784.00</i>
				<i>Shipping</i>			<i>321.00</i>
				<i>10 E 1130 4100 50 300 000000</i>			<i>784.00</i>
				<i>10 E 1130 4100 50 300 000000</i>			<i>321.00</i>
American Muscle Docks &			1,105.00				
Anagnos Door Co.		90323	KAS	Annual Fire Door Drop Testing	04/01/2021	082198	899.00
				<i>Annual Fire Door Drop Testing</i>			<i>899.00</i>
				<i>20 E 2540 3900 00 302 000000</i>			<i>899.00</i>
Anagnos Door Co.			899.00				
Andrew High School		2/13/21 Dance	KAS	Competitive Dance G V and JV vs Andrew Tournament Virtual Invitational	02/13/2021	082199	400.00
				<i>Dance Varsity</i>			<i>200.00</i>
				<i>Dance Jr. Varsity</i>			<i>200.00</i>
				<i>10 E 1500 3900 30 300 000000</i>			<i>200.00</i>
				<i>10 E 1500 3900 30 300 000000</i>			<i>200.00</i>
Andrew High School			400.00				

Invoice Listing

COUNTY OF GRUNDY SCHOOL DIST 111

Full Name	PO Number	Invoice Number	Batch	Description	Invoice Date	Check Number	Net Amount
Aqualab Water		6453	KAS	Water Treatment Chemicals - April 2021	04/01/2021	082200	375.00
				<i>Water Treatment Chemicals - April 2021</i>			375.00
				<i>20 E 2540 3900 00 302 000000</i>			375.00
Aqualab Water Treatment,			375.00				
Arriola, Jose	1032100146	63184 3/25/21	KAS	BSOC-V-3/25/21	03/25/2021	082201	65.00
				<i>BSOC-V-3/25/21</i>			65.00
				<i>10 E 1500 3190 30 300 000001</i>			65.00
Arriola, Jose	1032100174	63184 4-6-21	KAS	Official-BSOC-V-4/6	04/06/2021	082201	65.00
				<i>Official-BSOC-V-4/6</i>			65.00
				<i>10 E 1500 3190 30 300 000001</i>			65.00
Arriola, Jose			130.00				
Athletic Outfitters		16592	KAS	Clocks, Cones	04/14/2021	082347	410.95
				<i>Clocks, Cones</i>			410.95
				<i>10 E 2310 4100 00 300 000000</i>			410.95
Athletic Outfitters			410.95				

Invoice Listing

COUNTY OF GRUNDY SCHOOL DIST 111

Full Name	PO Number	Invoice Number	Batch	Description	Invoice Date	Check Number	Net Amount
Avant Assessment, LLC	1082100010	18170	KAS	testing materials	04/09/2021	082348	1,333.30
				<i>Testing materials for Jeffrey Easthon</i>			1,333.30
				<i>10 E 2210 3000 00 300 000006</i>			1,333.30
Avant Assessment, LLC			1,333.30				
Band Shoppe	1042100023	SIV1820848	KAS	Crutch Style Flag Polo Caps	03/25/2021	9100000331	1,672.20
				<i>Crutch Style Flag Polo Caps</i>			1,672.20
				<i>10 E 1500 4100 70 300 000010</i>			1,672.20
Band Shoppe			1,672.20				
Bannon Exterminating		12916	KAS	Exterminating 3/31/21 - South	03/31/2021	082202	175.00
				<i>Exterminating 3/31/21 - South</i>			175.00
				<i>20 E 2540 3000 00 302 000003</i>			175.00
Bannon Exterminating		12917	KAS	Exterminating 3/31/21 - Central	03/31/2021	082202	185.00
				<i>Exterminating 3/31/21 - Central</i>			185.00
				<i>20 E 2540 3000 00 300 000005</i>			185.00
Bannon Exterminating			360.00				

Invoice Listing

COUNTY OF GRUNDY SCHOOL DIST 111

Full Name	PO Number	Invoice Number	Batch	Description	Invoice Date	Check Number	Net Amount
Bauer, Nathan	1032100222	34465 4/15/21	KAS	Official-FR GVB-4/15/21	04/15/2021	082349	88.00
				<i>Official-FR GVB-4/15/21</i>			88.00
				<i>10 E 1500 3190 30 300 000000</i>			88.00
Bauer, Nathan			88.00				
Bayer Piano Service	1012100097	244	KAS	Piano Tuning	04/06/2021	082203	215.00
				<i>Piano tunings</i>			215.00
				<i>10 E 1130 3230 12 300 000001</i>			215.00
Bayer Piano Service			215.00				
Becker, Dana R		3/9/21 Walmart	KAS	Fish tanks, clear containers, fake flowers, tempera paint for Photo Classes: Stop Motion Photography	03/09/2021	9100000332	89 110.54
				<i>Fish tanks, clear containers, fake</i>			110.54
				<i>10 E 1130 4100 02 300 000000</i>			110.54
Becker, Dana R			110.54				
Besse, Steve	1032100125	23561 3/6/21	KAS	Girls Basketball-VAR-3-6-21	03/06/2021	082204	67.00
				<i>Girls Basketball-VAR-3-6-21</i>			67.00
				<i>10 E 1500 3190 30 300 000005</i>			67.00
Besse, Steve			67.00				

Invoice Listing

COUNTY OF GRUNDY SCHOOL DIST 111

Full Name	PO Number	Invoice Number	Batch	Description	Invoice Date	Check Number	Net Amount
Bialko, Mark	1032100151	83937 3/26/21	KAS	FB-SO-3-26	03/26/2021	082205	59.00
				<i>FB-SO-3-26</i>			<i>59.00</i>
				<i>10 E 1500 3190 30 300 000003</i>			<i>59.00</i>
	Bialko, Mark		59.00				
Blair, Peter	1032100185	34875 4/2/21	KAS	Official-FB-V-4/2/21	04/02/2021	082350	77.00
				<i>Official-FB-V-4/2/21</i>			<i>77.00</i>
				<i>10 E 1500 3190 30 300 000003</i>			<i>77.00</i>
	Blair, Peter		77.00				
Boardman, Troy	1032100107	59186 3/5/21	KAS	Boys Basketball VAR-3-5-21	03/05/2021	082206	90 67.00
				<i>Boys Basketball VAR-3-5-21</i>			<i>67.00</i>
				<i>10 E 1500 3190 30 300 000004</i>			<i>67.00</i>
	Boardman, Troy		67.00				

Invoice Listing

COUNTY OF GRUNDY SCHOOL DIST 111

Full Name	PO Number	Invoice Number	Batch	Description	Invoice Date	Check Number	Net Amount
Bonnar, Sarah J		2014100 570.00	KAS	ET5083 Educational Technology Systems Management, DL5023 The Digital Educator, DL5103 Instructional Models for the Digital Learners - American College of Education	03/22/2021	9100000358	1,665.00
				<i>ET5083 Educational Technology</i>			555.00
				<i>DL5023 The Digital Educator</i>			555.00
				<i>DL5103 Instructional Models for the</i>			555.00
				<i>10 E 1130 2300 00 300 000000</i>			555.00
				<i>10 E 1130 2300 00 300 000000</i>			555.00
				<i>10 E 1130 2300 00 300 000000</i>			555.00
Bonnar, Sarah J			1,665.00				91
Boor, John	1032100209	84961 4/13/21	KAS	Official-TR&FLD-4-13-21	04/13/2021	082351	97.00
				<i>Official-TR&FLD-4-13-21</i>			97.00
				<i>10 E 1500 3190 30 300 000010</i>			97.00
Boor, John	1032100226	84961 4/19/21	KAS	Official-BTR-4/19/21	04/19/2021	082351	97.00
				<i>Official-BTR-4/19/21</i>			97.00
				<i>10 E 1500 3190 30 300 000011</i>			97.00
Boor, John			194.00				

Invoice Listing

COUNTY OF GRUNDY SCHOOL DIST 111

Full Name	PO Number	Invoice Number	Batch	Description	Invoice Date	Check Number	Net Amount
Braner, Diane	1032100166	60760 3/30/21	KAS	GVB-3-30-21	03/30/2021	082207	89.00
				<i>GVB-3-30-21</i>			<i>89.00</i>
				<i>10 E 1500 3190 30 300 000000</i>			<i>89.00</i>
	Braner, Diane		89.00				
Broderick, James	1032100225	24579 4/15/21	KAS	Official-JV GSOC-4/15/21	04/15/2021	082352	61.00
				<i>Official-JV GSOC-4/15/21</i>			<i>61.00</i>
				<i>10 E 1500 3190 30 300 000012</i>			<i>61.00</i>
	Broderick, James		61.00				
BSN Sports Inc		911923610	KAS	Vertical Bar Holder	03/10/2021	082208	261.04
				<i>Vertical Bar Holder</i>			<i>261.04</i>
				<i>10 E 1130 4100 50 300 000000</i>			<i>261.04</i>
BSN Sports Inc		911952623	KAS	Diamond Turf Pitch Mat 4X12	03/12/2021	082208	297.00
				<i>Diamond Turf Pitch Mat 4X12</i>			<i>297.00</i>
				<i>10 E 1500 3000 30 300 000012</i>			<i>297.00</i>

92

Invoice Listing

COUNTY OF GRUNDY SCHOOL DIST 111

Full Name	PO Number	Invoice Number	Batch	Description	Invoice Date	Check Number	Net Amount	
BSN Sports Inc	1032100024	911498939	KAS	Wilson baseballs	01/23/2021	082208	1,428.32	
				Program jackets				
				<i>Wilson baseballs</i>				<i>1,400.00</i>
				<i>Freight for Baseballs and Jackets</i>				<i>28.32</i>
				<i>10 E 1500 4100 30 300 000010</i>				<i>1,400.00</i>
<i>10 E 1500 4100 30 300 000036</i>	<i>28.32</i>							
BSN Sports Inc	1032100026	911515352	KAS	Pitching screen.	01/26/2021	082208	521.00	
				<i>Pitching screen</i>				<i>521.00</i>
				<i>10 E 1500 4100 30 300 000036</i>				<i>521.00</i>
							93	

Invoice Listing

COUNTY OF GRUNDY SCHOOL DIST 111

Full Name	PO Number	Invoice Number	Batch	Description	Invoice Date	Check Number	Net Amount
BSN Sports Inc	1122100020	911864504	KAS	Fitness Equipment	03/04/2021	082208	4,114.96
				<i>Reactor 75CM Anti Burst Fitness Ball</i>			168.00
				<i>Large Ball/Fitness Cart</i>			220.00
				<i>Kettlebell Storage Rack</i>			550.00
				<i>Commercial Suspension Trainers</i>			2,028.00
				<i>3 in 1 Plyo Cube</i>			700.00
				<i>6 Tier Rolling Medicine Ball Rack</i>			275.00
				<i>Shipping</i>			173.96
				<i>10 E 1130 4100 50 300 000000</i>			168.00
				<i>10 E 1130 4100 50 300 000000</i>			220.00
				<i>10 E 1130 4100 50 300 000000</i>			550.00
				<i>10 E 1130 4100 50 300 000000</i>			2,028.00
				<i>10 E 1130 4100 50 300 000000</i>			700.00
				<i>10 E 1130 4100 50 300 000000</i>			275.00
				<i>10 E 1130 4100 50 300 000000</i>			173.96
							94

Invoice Listing

COUNTY OF GRUNDY SCHOOL DIST 111

Full Name	PO Number	Invoice Number	Batch	Description	Invoice Date	Check Number	Net Amount
BSN Sports Inc		012337292	KAS	Lacrosse Balls, Lacrosse Coach's Brd, Mens Lacrosse (26 matches)	04/15/2021	082353	175.50
				<i>Lacrosse Balls</i>			150.00
				<i>Lacrosse Coach's Brd</i>			8.00
				<i>Mens Lacrosse (26 matches)</i>			17.50
				<i>10 E 1500 4100 30 300 000026</i>			150.00
				<i>10 E 1500 4100 30 300 000026</i>			8.00
				<i>10 E 1500 4100 30 300 000026</i>			17.50
BSN Sports Inc		912445161	KAS	SS Flex Polos	04/22/2021	082353	240.75 95
				<i>SS Flex Polos</i>			240.75
				<i>10 E 2310 4100 00 300 000000</i>			240.75
BSN Sports Inc			7,038.57				
Buckley, Robert	1032100241	30900 4/23/21	KAS	Official-FB-VAR-4/23/21	04/23/2021	082354	77.00
				<i>Official-FB-VAR-4/23/21</i>			77.00
				<i>10 E 1500 3190 30 300 000003</i>			77.00
Buckley, Robert			77.00				

Invoice Listing

COUNTY OF GRUNDY SCHOOL DIST 111

Full Name	PO Number	Invoice Number	Batch	Description	Invoice Date	Check Number	Net Amount
Buffalo Grove High		1/29/21 Cheerleading	KAS	Cheerleading Bison Invite - 2 teams	01/29/2021	082209	450.00
				<i>Cheerleading Bison Invite - 2 teams</i>			450.00
				<i>10 E 1500 3900 30 300 000000</i>			450.00
Buffalo Grove High School			450.00				
Buzenski, Brad	1032100136	18942 3/18/21	KAS	Girls Volleyball-JV&V-3/18/21	03/18/2021	082210	89.00
				<i>Girls Volleyball-JV&V-3/18/21</i>			89.00
				<i>10 E 1500 3190 30 300 000000</i>			89.00
Buzenski, Brad	1032100204	18942 4/14/21	KAS	Official-GVB-4/14/21	04/14/2021	082355	89.00
				<i>Official-GVB-4/14/21</i>			89.00
				<i>10 E 1500 3190 30 300 000000</i>			89.00
Buzenski, Brad	1032100239	18942 4/24/21	KAS	Official-GVB-4/24/21	04/24/2021	082355	56.00
				<i>Official-GVB-4/24/21</i>			56.00
				<i>10 E 1500 3190 30 300 000000</i>			56.00
Buzenski, Brad			234.00				

Invoice Listing

COUNTY OF GRUNDY SCHOOL DIST 111

Full Name	PO Number	Invoice Number	Batch	Description	Invoice Date	Check Number	Net Amount
Canna Law Offices P.C.		587	KAS	Legal Services - Tennis Court Litigation	04/01/2021	9100000359	225.00
				<i>Legal Services - Tennis Court Litigation</i>			225.00
				<i>80 E 2310 3180 00 300 000000</i>			225.00
Canna Law Offices P.C.			225.00				
Carlin Supply		5000810-00	KAS	Supplies for horticulture explorations	04/01/2021	082211	155.10
				<i>Supplies for horticulture explorations</i>			155.10
				<i>10 E 1401 4100 01 300 000000</i>			155.10
Carlin Supply		599373-00	KAS	Supplies for horticulture explorations, greenhouse planters.	03/16/2021	082211	295.00
				<i>Supplies for horticulture explorations,</i>			295.00
				<i>10 E 1401 4100 01 300 000000</i>			295.00
Carlin Supply			450.10				
Cathelyn, Kevin	1032100201	68462 4/12/21	KAS	Official-BSOC-4/12/21	04/12/2021	082356	65.00
				<i>Official-BSOC-4/12/21</i>			65.00
				<i>10 E 1500 3190 30 300 000001</i>			65.00
Cathelyn, Kevin			65.00				

Invoice Listing

COUNTY OF GRUNDY SCHOOL DIST 111

Full Name	PO Number	Invoice Number	Batch	Description	Invoice Date	Check Number	Net Amount
Central States Bus		IN495278	KAS	Clutch	03/05/2021	082212	1,052.18
				<i>Clutch</i>			<i>1,052.18</i>
				<i>40 E 2554 3230 00 300 000000</i>			<i>1,052.18</i>
Central States Bus		IN496242	KAS	Belt	03/12/2021	082212	92.55
				<i>Belt</i>			<i>92.55</i>
				<i>40 E 2554 3230 00 300 000000</i>			<i>92.55</i>
Central States Bus		IN496245	KAS	Alternator, Automatic Belt Tensioner	03/12/2021	082212	663.44
				<i>Alternator</i>			<i>522.74</i>
				<i>Automatic Belt Tensioner</i>			<i>140.70</i>
				<i>40 E 2554 3230 00 300 000000</i>			<i>522.74</i>
				<i>40 E 2554 3230 00 300 000000</i>			<i>140.70</i>
Central States Bus		IN500203	KAS	Arm Crossing Polyrod, Base Crossing Electric	04/14/2021	082357	896.33
				<i>Arm Crossing Polyrod</i>			<i>183.90</i>
				<i>Base Crossing Electric</i>			<i>712.43</i>
				<i>40 E 2554 3230 00 300 000000</i>			<i>183.90</i>
				<i>40 E 2554 3230 00 300 000000</i>			<i>712.43</i>

Invoice Listing

COUNTY OF GRUNDY SCHOOL DIST 111

Full Name	PO Number	Invoice Number	Batch	Description	Invoice Date	Check Number	Net Amount
Central States Bus		IN500206	KAS	Clutch Fan	04/14/2021	082357	1,295.17
				<i>Clutch Fan</i>			1,295.17
				<i>40 E 2554 3230 00 300 000000</i>			1,295.17
Central States Bus Sales			3,999.67				
Cetera, Stephen	1032100121	59543 3/12/21	KAS	Soccer-FR 3-12-21	03/12/2021	082213	61.00
				<i>Soccer-FR 3-12-21</i>			61.00
				<i>10 E 1500 3190 30 300 000001</i>			61.00
Cetera, Stephen	1032100173	59543 4/6/21	KAS	Official-BSOC-V-4/6	04/06/2021	082213	65.00
				<i>Official-BSOC-V-4/6</i>			65.00
				<i>10 E 1500 3190 30 300 000001</i>			65.00
Cetera, Stephen			126.00				
Childress, Derrick	1032100180	28255 4/2/21	KAS	Official-FB-S-4/2/21	04/02/2021	082358	59.00
				<i>Official-FB-S-4/2/21</i>			59.00
				<i>10 E 1500 3190 30 300 000003</i>			59.00
Childress, Derrick			59.00				

Invoice Listing

COUNTY OF GRUNDY SCHOOL DIST 111

Full Name	PO Number	Invoice Number	Batch	Description	Invoice Date	Check Number	Net Amount
Cladis, Nick	1032100110	11997 3/8/21	KAS	Boys Basketball VAR-3-8-21	03/08/2021	082214	67.00
				<i>Boys Basketball VAR-3-8-21</i>			67.00
				<i>10 E 1500 3190 30 300 000004</i>			67.00
Cladis, Nick			67.00				
Clennon Electric		39688	KAS	Troubleshoot NE Parking Lot Fixtures	04/20/2021	9100000360	2,400.50
				<i>Troubleshoot NE Parking Lot Fixtures</i>			2,400.50
				<i>20 E 2540 3230 00 302 000000</i>			2,400.50
Clennon Electric		39697	KAS	Repair Parking Lot Lighting	04/21/2021	9100000360	1,520.37
				<i>Repair Parking Lot Lighting</i>			1,520.37
				<i>20 E 2540 3230 00 302 000000</i>			1,520.37
Clennon Electric			3,920.87				
Collegeboard	1012100094	2ZWNWY328SG	KAS	Professional Development AP course	03/26/2021	082215	175.00
				<i>AP Conference</i>			175.00
				<i>10 E 2210 3000 15 300 000000</i>			175.00
Collegeboard			175.00				

Invoice Listing

COUNTY OF GRUNDY SCHOOL DIST 111

Full Name	PO Number	Invoice Number	Batch	Description	Invoice Date	Check Number	Net Amount
Comcast		8771200230111706	KAS	Internet for Project Indian 3/29 to 4/28/21	03/22/2021	082216	88.40
				<i>Internet for Project Indian 3/29 to 4/28/21</i>			88.40
				<i>10 E 2225 3000 00 300 000001</i>			88.40
Comcast			88.40				
Comcast Business		118327191	KAS	Internet Service through 2/28/21	03/01/2021	082217	5,005.66
				<i>Internet Service through 2/28/21</i>			5,005.66
				<i>10 E 2225 3000 00 300 000001</i>			5,005.66
Comcast Business		120189100	KAS	Internet Service through 3/31/21	04/01/2021	082359	5,009.49
				<i>Internet Service through 3/31/21</i>			5,009.49
				<i>10 E 2225 3000 00 300 000001</i>			5,009.49
Comcast Business			10,015.15				
Condon, Joyce	1032100172	51329 4/6/21	KAS	Official-GVB-V&JV-4/6	04/06/2021	082360	89.00
				<i>Official-GVB-V&JV-4/6</i>			89.00
				<i>10 E 1500 3190 30 300 000000</i>			89.00
Condon, Joyce	1032100205	51329 4/14/21	KAS	Official-GVB-4/14/21	04/14/2021	082360	89.00
				<i>Official-GVB-4/14/21</i>			89.00
				<i>10 E 1500 3190 30 300 000000</i>			89.00

Invoice Listing

COUNTY OF GRUNDY SCHOOL DIST 111

Full Name	PO Number	Invoice Number	Batch	Description	Invoice Date	Check Number	Net Amount
Condon, Joyce	1032100230	51329 4/21/21	KAS	Official-GVB-V-4/21/21	04/21/2021	082361	56.00
				<i>Official-GVB-V-4/21/21</i>			56.00
				<i>10 E 1500 3190 30 300 000000</i>			56.00
Condon, Joyce			234.00				
Constellation New		19611115901	KAS	Electric Supply 2/5 to 3/8/21 Central Campus	03/09/2021	082218	21,008.85
				<i>Electric Supply 2/5 to 3/8/21 Central</i>			21,008.85
				<i>20 E 2540 4660 00 300 000000</i>			21,008.85
Constellation New		19697239001	KAS	Electric Supply 2/16 to 3/17/21 South Campus	03/19/2021	082218	22,470.90
				<i>Electric Supply 2/16 to 3/17/21 South</i>			22,470.90
				<i>20 E 2540 4660 00 302 000000</i>			22,470.90
Constellation New		7287504-3	KAS	Electricity Supply 2/15 to 3/16/2021 Project Indian	03/17/2021	082218	109.21
				<i>Electricity Supply 2/15 to 3/16/2021</i>			109.21
				<i>20 E 2540 3400 00 301 000000</i>			109.21
Constellation New Energy			43,588.96				
Crescent Electric		S508919183.001	KAS	Leviton Wh Pir Occ Sens Wall	03/22/2021	082219	163.94
				<i>Leviton Wh Pir Occ Sens Wall</i>			163.94
				<i>20 E 2540 4100 00 302 000000</i>			163.94

Invoice Listing

COUNTY OF GRUNDY SCHOOL DIST 111

Full Name	PO Number	Invoice Number	Batch	Description	Invoice Date	Check Number	Net Amount
Crescent Electric		S508992562.001	KAS	Buss Fusetron Dual Element Fuse, E-flex, Thhn 2 blk, Burndy Side Unitap	04/09/2021	082362	475.33
				<i>Buss Fusetron Dual Element Fuse</i>			248.70
				<i>E-flex 10 ft.</i>			9.51
				<i>Thhn 2 blk 40 ft.</i>			97.17
				<i>Burndy Side Unitap</i>			119.95
				<i>20 E 2540 4100 00 302 000000</i>			248.70
				<i>20 E 2540 4100 00 302 000000</i>			9.51
				<i>20 E 2540 4100 00 302 000000</i>			97.17
				<i>20 E 2540 4100 00 302 000000</i>			119.95
							103
Crescent Electric Supply			639.27				
Culligan		202103138811	KAS	Solar Salt Delivery 3/9, 3/23/21	03/31/2021	082220	243.18
				<i>Solar Salt Delivery 3/9, 3/23/21</i>			243.18
				<i>20 E 2540 3900 00 302 000000</i>			243.18
Culligan			243.18				
Cummins Sales and		E3-72332	KAS	Insite Pro	03/26/2021	082221	770.00
				<i>Insite Pro</i>			770.00
				<i>40 E 2552 4100 00 300 000000</i>			770.00
Cummins Sales and Service			770.00				

Invoice Listing

COUNTY OF GRUNDY SCHOOL DIST 111

Full Name	PO Number	Invoice Number	Batch	Description	Invoice Date	Check Number	Net Amount
Curran, Jeff	1032100243	12829 4/23/21	KAS	Official-FB-VAR-4/23/21	04/23/2021	082363	77.00
				<i>Official-FB-VAR-4/23/21</i>			77.00
				<i>10 E 1500 3190 30 300 000003</i>			77.00
Curran, Jeff			77.00				
Currier, Cara	1032100133	34963 3/17/21	KAS	Volleyball-Girls FR A&B - 3/17/21	03/17/2021	082222	88.00
				<i>Volleyball-Girls FR A&B - 3/17/21</i>			88.00
				<i>10 E 1500 3190 30 300 000000</i>			88.00
Currier, Cara			88.00				
Cutting Edge Document		m13568	KAS	Records Shred March 2021	03/16/2021	9100000333	104 60.00
				<i>Records Shred March 2021</i>			60.00
				<i>10 E 2525 3000 00 300 000000</i>			60.00
Cutting Edge Document		m13888	KAS	Records Shred April 2021	04/06/2021	9100000333	60.00
				<i>Records Shred April 2021</i>			60.00
				<i>10 E 2525 3000 00 300 000000</i>			60.00
Cutting Edge Document			120.00				

Invoice Listing

COUNTY OF GRUNDY SCHOOL DIST 111

Full Name	PO Number	Invoice Number	Batch	Description	Invoice Date	Check Number	Net Amount
D'Arcy Chevrolet Buick		68140	KAS	Control	03/18/2021	082223	163.59
				<i>Control</i>			163.59
				<i>40 E 2554 3230 00 300 000000</i>			163.59
D'Arcy Chevrolet Buick			163.59				
Darst, Scott	1032100231	84011 4/10/21	KAS	Official-FB-FR-4/10/21	04/10/2021	082364	74.00
				<i>Official-FB-FR-4/10/21</i>			74.00
				<i>10 E 1500 3190 30 300 000003</i>			74.00
Darst, Scott			74.00				
Defreitas, John	1032100203	13196 4/14/21	KAS	Official-GVB-4/14/21	04/14/2021	082365	105 88.00
				<i>Official-GVB-4/14/21</i>			88.00
				<i>10 E 1500 3190 30 300 000000</i>			88.00
Defreitas, John			88.00				
Demco Inc.	1012100077	6919478	KAS	Library Supplies Order for Genre Project	03/09/2021	082224	744.55
				<i>Library Supplies order for Genre Project</i>			744.55
				<i>10 E 2222 4100 00 300 000000</i>			744.55
Demco Inc.			744.55				

Invoice Listing

COUNTY OF GRUNDY SCHOOL DIST 111

Full Name	PO Number	Invoice Number	Batch	Description	Invoice Date	Check Number	Net Amount
Depue Mechanical		2020/1061	KAS	Inspect Equipment	10/31/2020	082366	2,160.00
				<i>Inspect Equipment</i>			2,160.00
				<i>20 E 2540 3230 00 302 000001</i>			2,160.00
Depue Mechanical		2020/2060	KAS	Hot Water Circ. Pump - repair wiring and pump	10/31/2020	082366	2,000.00
				<i>Hot Water Circ. Pump - repair wiring and</i>			2,000.00
				<i>20 E 2540 3230 00 302 000001</i>			2,000.00
Depue Mechanical			4,160.00				
Dimitri, Justin	1032100214	88244 4/17/21	KAS	Official-FR FB-4/17/21	04/17/2021	082367	59.00
				<i>Official-FR FB-4/17/21</i>			59.00
				<i>10 E 1500 3190 30 300 000003</i>			59.00
Dimitri, Justin			59.00				
Dorick, Bradley A		3/26/21 Menards	KAS	Pollinator Garden Supplies for Science from Menards	03/25/2021	9100000334	66.95
				<i>Pollinator Garden Supplies for Science</i>			66.95
				<i>10 E 1130 4100 13 300 000000</i>			66.95

Invoice Listing

COUNTY OF GRUNDY SCHOOL DIST 111

Full Name	PO Number	Invoice Number	Batch	Description	Invoice Date	Check Number	Net Amount
Dorick, Bradley A		4/19/21 Menards	KAS	Scrub Brushes and Hedge Shears for Pollinator Garden from Menards	04/16/2021	9100000361	20.55
				<i>Scrub Brushes and Hedge Shears for</i>			20.55
				<i>10 E 1130 4100 13 300 000000</i>			20.55
Dorick, Bradley A			87.50				
Downers Grove South	1012100084	3/17/21 Music Bowl	KAS	Music Bowl Marching Band Competition	03/17/2021	082225	200.00
				<i>Marching Band Competition "Music</i>			200.00
				<i>10 E 1130 6400 12 300 000003</i>			200.00
Downers Grove South Hs			200.00				
Eamon, Ervin	1032100215	70603 4/17/21	KAS	Official-FR FB-4/17/21	04/17/2021	082368	107 59.00
				<i>Official-FR FB-4/17/21</i>			59.00
				<i>10 E 1500 3190 30 300 000003</i>			59.00
Eamon, Ervin	1032100234	70603 4/24/21	KAS	Official-Boys Lacrosse - 4/24/21	04/24/2021	082368	68.00
				<i>Official-Boys Lacrosse - 4/24/21</i>			68.00
				<i>10 E 1500 3190 30 300 000014</i>			68.00
Eamon, Ervin			127.00				

Invoice Listing

COUNTY OF GRUNDY SCHOOL DIST 111

Full Name	PO Number	Invoice Number	Batch	Description	Invoice Date	Check Number	Net Amount
Ebsco	1012100062	1000151199-1	KAS	Flipster Online Periodicals Renewal	03/12/2021	082226	976.83
				<i>Flipster Online Periodicals Renewal</i>			976.83
				<i>10 E 2222 4400 00 300 000000</i>			976.83
Ebsco			976.83				
Echo Bowling Lanes		3/12/21 Conference	KAS	Boys Bowling Tournament 3/12 and 3/13/21	03/13/2021	082227	1,876.00
				<i>Boys Bowling Tournament 3/12/21</i>			1,008.00
				<i>Boys Bowling Tournament 3/13/21</i>			868.00
				<i>10 E 1500 3900 30 300 000001</i>			1,008.00
				<i>10 E 1500 3900 30 300 000001</i>			868.00
Echo Bowling Lanes			1,876.00				
Edwards, Jerry B		3/24/21 Postage	KAS	Post Office Mailing - MCHS Foundation Filing	03/24/2021	082228	26.35
				<i>Post Office Mailing - MCHS Foundation</i>			26.35
				<i>10 E 2410 3400 00 300 000000</i>			26.35
Edwards, Jerry B			26.35				
El Khatib, Ahmad		3/22/21 Khatib	KAS	Deposition with Canna Law Offices - Tennis Court Litigation	03/22/2021	082229	1,991.25
				<i>Deposition with Canna Law Offices -</i>			1,991.25
				<i>80 E 2310 3180 00 300 000000</i>			1,991.25
El Khatib, Ahmad			1,991.25				

Invoice Listing

COUNTY OF GRUNDY SCHOOL DIST 111

Full Name	PO Number	Invoice Number	Batch	Description	Invoice Date	Check Number	Net Amount
Energy Systems Group		99001784	KAS	Payment Application #5 Guaranteed Energy Savings Performance Contract 2/20/20	04/19/2021	082369	61,302.36
				<i>Payment Application #5 Guaranteed</i>			61,302.36
				<i>90 E 2542 5300 00 300 000000</i>			61,302.36
Energy Systems Group			61,302.36				
Evans, Craig	1032100235	68848 4/24/21	KAS	Official-Boys Lacrosse - 4/24/21	04/24/2021	082370	68.00
				<i>Official-Boys Lacrosse - 4/24/21</i>			68.00
				<i>10 E 1500 3190 30 300 000014</i>			68.00
Evans, Craig			68.00				
Ewerts Automotive		10647	KAS	Replaced Catalytic Converter Assembly	03/19/2021	9100000335	1,868.63
				<i>Replaced Catalytic Converter Assembly</i>			1,868.63
				<i>40 E 2554 3230 00 300 000000</i>			1,868.63
Ewerts Automotive			1,868.63				
Facko, Gary	1032100161	46677 3/29/21	KAS	Boys Soccer-VAR-3/29/21	03/29/2021	082230	65.00
				<i>Boys Soccer-VAR-3/29/21</i>			65.00
				<i>10 E 1500 3190 30 300 000001</i>			65.00
Facko, Gary			65.00				

Invoice Listing

COUNTY OF GRUNDY SCHOOL DIST 111

Full Name	PO Number	Invoice Number	Batch	Description	Invoice Date	Check Number	Net Amount
Feece Oil Company		3770062	KAS	Prem Hwy DSL Fuel 1405 Gal.	04/05/2021	082231	3,684.12
				<i>Prem Hwy DSL Fuel 1405 Gal.</i>			3,684.12
				<i>40 E 2552 4640 00 300 000000</i>			3,684.12
Feece Oil Company		3771656	KAS	Prem Hwy DSL Fuel 1500 Gal.	03/13/2021	082231	4,017.21
				<i>Prem Hwy DSL Fuel 1500 Gal.</i>			4,017.21
				<i>40 E 2552 4640 00 300 000000</i>			4,017.21
Feece Oil Company		3773907	KAS	Prem Hwy DSL Fuel 1500 Gal.	03/25/2021	082231	3,777.21
				<i>Prem Hwy DSL Fuel 1500 Gal.</i>			3,777.21
				<i>40 E 2552 4640 00 300 000000</i>			3,777.21

110

Invoice Listing

COUNTY OF GRUNDY SCHOOL DIST 111

Full Name	PO Number	Invoice Number	Batch	Description	Invoice Date	Check Number	Net Amount
Feece Oil Company		467690 3/31/21	KAS	Bus, Driver's Ed, Van and Grounds Gasoline	03/31/2021	082231	4,190.22
				1950398 bus 76			32.42
				1950469 bus 22			43.25
				1950566 bus 132			40.23
				1950581 bus 76			40.03
				1950650 bus 132			35.27
				1950655 bus 40			41.44
				1950732 bus 61			49.82
				1950743 bus 72			51.64
				1950747 bus 72			54.66
				1950765 bus 1			44.08
				1950764 bus 22			29.94
				1950836 bus 132			39.54
				1950901 bus 48			37.53
				1950910 bus 76			36.90
				1950997 bus 132			36.32
				1951038 bus 1			38.80
				1951077 bus 76			33.92
				1951070 bus 72			27.24

111

Invoice Listing

COUNTY OF GRUNDY SCHOOL DIST 111

Full Name	PO Number	Invoice Number	Batch	Description	Invoice Date	Check Number	Net Amount	
				1951156 bus 132			35.52	
				1951186 bus 1			38.69	
				1951203 bus 72			62.05	
				1951298 bus 76			30.62	
				1951311 bus 48			43.70	
				1951463 bus 132			38.88	
				1951491 bus 57			45.07	
				1951478 bus 76			37.58	
				1951557 bus 72			20.50	112
				1951634 bus 132			27.22	
				1951673 bus 48			39.27	
				1951761 bus 72			55.98	
				1951830 bus 76			35.72	
				1952003 bus 61			55.98	
				1951998 bus 72			44.92	
				1951996 bus 132			38.85	
				1952011 bus 76			32.56	
				1952024 bus 48			37.97	
				1952144 bus 84			66.15	

Invoice Listing

COUNTY OF GRUNDY SCHOOL DIST 111

Full Name	PO Number	Invoice Number	Batch	Description	Invoice Date	Check Number	Net Amount	
				1952274 bus 132			37.62	
				1952291 bus 76			31.40	
				1952369 bus 72			46.74	
				1952427 bus 132			41.19	
				1952439 bus 76			35.83	
				1952460 bus 48			43.06	
				1952513 bus 57			56.02	
				1952574 bus 132			36.49	
				1952683 bus 61			37.44	113
				1952733 bus 132			36.73	
				1952748 bus 76			37.06	
				1952766 bus 48			35.44	
				1952813 bus 1			42.73	
				1952834 bus 72			61.59	
				1952904 bus 132			41.75	
				1952908 bus 84			61.05	
				1952920 bus 76			36.28	
				1953184 bus 132			32.43	
				1953202 bus 76			31.84	

Invoice Listing

COUNTY OF GRUNDY SCHOOL DIST 111

Full Name	PO Number	Invoice Number	Batch	Description	Invoice Date	Check Number	Net Amount	
				1953221 bus 84			42.82	
				1953197 bus 72			72.05	
				1953361 bus 72			40.76	
				1953365 bus 76			37.79	
				1953350 bus 132			44.37	
				1953456 bus 57			56.18	
				1953532 bus 132			36.69	
				1953567 bus 48			37.95	
				1953584 bus 56			45.02	114
				1953715 bus 132			36.37	
				1953727 bus 76			37.44	
				1953757 bus 56			36.96	
				1953802 bus 72			58.36	
				1955046 bus 84			56.20	
				1955105 bus 132			36.58	
				1955111 bus 61			51.78	
				1955144 bus 48			40.38	
				1955115 bus 76			30.36	
				1955151 bus 56			38.02	

Invoice Listing

COUNTY OF GRUNDY SCHOOL DIST 111

Full Name	PO Number	Invoice Number	Batch	Description	Invoice Date	Check Number	Net Amount
				1955202 bus 72			43.15
				1955211 bus 57			27.45
				1950584 van 30			31.74
				1950726 van 8			16.54
				1950917 shop truck			61.81
				1950916 grounds			32.71
				1951269 gas cans			74.20
				1951923 van 27			37.21
				1952009 van 30			36.55
				1952471 van 36			24.78
				1952612 van 35			35.83
				1952763 van 37			64.83
				1952910 shop truck			58.25
				1953395 maintenance			76.59
				1950429 car 5			19.61
				1950418 car 6			20.96
				1950416 car 25			31.05
				1950759 car 3			22.95
				1951096 car 5			19.17

115

Invoice Listing

COUNTY OF GRUNDY SCHOOL DIST 111

Full Name	PO Number	Invoice Number	Batch	Description	Invoice Date	Check Number	Net Amount	
				1951138 car 25			32.09	
				1951320 car 6			21.40	
				1951500 car 3			30.52	
				1951883 car 5			19.14	
				1952128 car 25			30.16	
				1952109 car 6			23.37	
				1952303 car 3			31.15	
				1952804 car 2			29.95	
				1952940 car 5			17.06	116
				1953378 car 3			34.50	
				1953790 car 6			21.10	
				1951813 bus 132			45.37	
				40 E 2552 4640 00 300 000000			32.42	
				40 E 2552 4640 00 300 000000			43.25	
				40 E 2552 4640 00 300 000000			40.23	
				40 E 2552 4640 00 300 000000			40.03	
				40 E 2552 4640 00 300 000000			35.27	
				40 E 2552 4640 00 300 000000			41.44	
				40 E 2552 4640 00 300 000000			49.82	
				40 E 2552 4640 00 300 000000			51.64	

Invoice Listing

COUNTY OF GRUNDY SCHOOL DIST 111

Full Name	PO Number	Invoice Number	Batch	Description	Invoice Date	Check Number	Net Amount
				40 E 2552 4640 00 300 000000			54.66
				40 E 2552 4640 00 300 000000			44.08
				40 E 2552 4640 00 300 000000			29.94
				40 E 2552 4640 00 300 000000			39.54
				40 E 2552 4640 00 300 000000			37.53
				40 E 2552 4640 00 300 000000			36.90
				40 E 2552 4640 00 300 000000			36.32
				40 E 2552 4640 00 300 000000			38.80
				40 E 2552 4640 00 300 000000			33.92
				40 E 2552 4640 00 300 000000			27.24
				40 E 2552 4640 00 300 000000			35.52
				40 E 2552 4640 00 300 000000			38.69
				40 E 2552 4640 00 300 000000			62.05
				40 E 2552 4640 00 300 000000			30.62
				40 E 2552 4640 00 300 000000			43.70
				40 E 2552 4640 00 300 000000			38.88
				40 E 2552 4640 00 300 000000			45.07
				40 E 2552 4640 00 300 000000			37.58
				40 E 2552 4640 00 300 000000			20.50
				40 E 2552 4640 00 300 000000			27.22
				40 E 2552 4640 00 300 000000			39.27

117

Invoice Listing

COUNTY OF GRUNDY SCHOOL DIST 111

Full Name	PO Number	Invoice Number	Batch	Description	Invoice Date	Check Number	Net Amount
				40 E 2552 4640 00 300 000000			55.98
				40 E 2552 4640 00 300 000000			35.72
				40 E 2552 4640 00 300 000000			55.98
				40 E 2552 4640 00 300 000000			44.92
				40 E 2552 4640 00 300 000000			38.85
				40 E 2552 4640 00 300 000000			32.56
				40 E 2552 4640 00 300 000000			37.97
				40 E 2552 4640 00 300 000000			66.15
				40 E 2552 4640 00 300 000000			37.62
				40 E 2552 4640 00 300 000000			31.40
				40 E 2552 4640 00 300 000000			46.74
				40 E 2552 4640 00 300 000000			41.19
				40 E 2552 4640 00 300 000000			35.83
				40 E 2552 4640 00 300 000000			43.06
				40 E 2552 4640 00 300 000000			56.02
				40 E 2552 4640 00 300 000000			36.49
				40 E 2552 4640 00 300 000000			37.44
				40 E 2552 4640 00 300 000000			36.73
				40 E 2552 4640 00 300 000000			37.06
				40 E 2552 4640 00 300 000000			35.44
				40 E 2552 4640 00 300 000000			42.73

118

Invoice Listing

COUNTY OF GRUNDY SCHOOL DIST 111

Full Name	PO Number	Invoice Number	Batch	Description	Invoice Date	Check Number	Net Amount
				40 E 2552 4640 00 300 000000			61.59
				40 E 2552 4640 00 300 000000			41.75
				40 E 2552 4640 00 300 000000			61.05
				40 E 2552 4640 00 300 000000			36.28
				40 E 2552 4640 00 300 000000			32.43
				40 E 2552 4640 00 300 000000			31.84
				40 E 2552 4640 00 300 000000			42.82
				40 E 2552 4640 00 300 000000			72.05
				40 E 2552 4640 00 300 000000			40.76
				40 E 2552 4640 00 300 000000			37.79
				40 E 2552 4640 00 300 000000			44.37
				40 E 2552 4640 00 300 000000			56.18
				40 E 2552 4640 00 300 000000			36.69
				40 E 2552 4640 00 300 000000			37.95
				40 E 2552 4640 00 300 000000			45.02
				40 E 2552 4640 00 300 000000			36.37
				40 E 2552 4640 00 300 000000			37.44
				40 E 2552 4640 00 300 000000			36.96
				40 E 2552 4640 00 300 000000			58.36
				40 E 2552 4640 00 300 000000			56.20
				40 E 2552 4640 00 300 000000			36.58

119

Invoice Listing

COUNTY OF GRUNDY SCHOOL DIST 111

Full Name	PO Number	Invoice Number	Batch	Description	Invoice Date	Check Number	Net Amount
				40 E 2552 4640 00 300 000000			51.78
				40 E 2552 4640 00 300 000000			40.38
				40 E 2552 4640 00 300 000000			30.36
				40 E 2552 4640 00 300 000000			38.02
				40 E 2552 4640 00 300 000000			43.15
				40 E 2552 4640 00 300 000000			27.45
				40 E 2550 4640 00 300 000000			31.74
				40 E 2550 4640 00 300 000000			16.54
				40 E 2550 4640 00 300 000000			61.81
				40 E 2550 4640 00 300 000000			32.71
				40 E 2550 4640 00 300 000000			74.20
				40 E 2550 4640 00 300 000000			37.21
				40 E 2550 4640 00 300 000000			36.55
				40 E 2550 4640 00 300 000000			24.78
				40 E 2550 4640 00 300 000000			35.83
				40 E 2550 4640 00 300 000000			64.83
				40 E 2550 4640 00 300 000000			58.25
				40 E 2550 4640 00 300 000000			76.59
				40 E 2550 4640 00 300 000000			19.61
				40 E 2550 4640 00 300 000000			20.96
				40 E 2550 4640 00 300 000000			31.05

120

Invoice Listing

COUNTY OF GRUNDY SCHOOL DIST 111

Full Name	PO Number	Invoice Number	Batch	Description	Invoice Date	Check Number	Net Amount
				40 E 2550 4640 00 300 000000			22.95
				40 E 2550 4640 00 300 000000			19.17
				40 E 2550 4640 00 300 000000			32.09
				40 E 2550 4640 00 300 000000			21.40
				40 E 2550 4640 00 300 000000			30.52
				40 E 2550 4640 00 300 000000			19.14
				40 E 2550 4640 00 300 000000			30.16
				40 E 2550 4640 00 300 000000			23.37
				40 E 2550 4640 00 300 000000			31.15
				40 E 2550 4640 00 300 000000			29.95
				40 E 2550 4640 00 300 000000			17.06
				40 E 2550 4640 00 300 000000			34.50
				40 E 2550 4640 00 300 000000			21.10
				40 E 2552 4640 00 300 000000			45.37
Feece Oil Company		3777457	KAS	Prem Hwy DSL Fuel 1600 Gal.	04/12/2021	082371	4,003.42
				Prem Hwy DSL Fuel 1600 Gal.			4,003.42
				40 E 2552 4640 00 300 000000			4,003.42

121

Invoice Listing

COUNTY OF GRUNDY SCHOOL DIST 111

Full Name	PO Number	Invoice Number	Batch	Description	Invoice Date	Check Number	Net Amount
Feece Oil Company		3779393	KAS	Prem Hwy DSL Fuel 800 Gal.	04/19/2021	082371	2,062.51
				<i>Prem Hwy DSL Fuel 800 Gal.</i>			<i>2,062.51</i>
				<i>40 E 2552 4640 00 300 000000</i>			<i>2,062.51</i>
Feece Oil Company		3780029	KAS	BlueDEF Exhaust Fluid, Bulk 231 gal.	04/22/2021	082371	353.43
				<i>BlueDEF Exhaust Fluid, Bulk 231 gal.</i>			<i>353.43</i>
				<i>40 E 2552 4640 00 300 000000</i>			<i>353.43</i>
Feece Oil Company			22,088.12				
Feed Loft Inc.		2	KAS	Ag Supplies	04/24/2020	082232	140.91
				<i>Ag Supplies</i>			<i>140.91</i>
				<i>10 E 1401 4100 01 300 000000</i>			<i>140.91</i>
Feed Loft Inc.		3	KAS	Ag Supplies	04/23/2020	082232	86.22
				<i>Ag Supplies</i>			<i>86.22</i>
				<i>10 E 1401 4100 01 300 000000</i>			<i>86.22</i>
Feed Loft Inc.			227.13				

Invoice Listing

COUNTY OF GRUNDY SCHOOL DIST 111

Full Name	PO Number	Invoice Number	Batch	Description	Invoice Date	Check Number	Net Amount
Feeney, Dan	1032100192	19262 4/9/21	KAS	Official-GVB-4-9-21	04/09/2021	082372	89.00
				<i>Official-GVB-4-9-21</i>			89.00
				<i>10 E 1500 3190 30 300 000000</i>			89.00
	Feeney, Dan		89.00				
Fitzgerald, Michael	1032100213	85962 4/17/21	KAS	Official-FR FB-4/17/21	04/17/2021	082373	59.00
				<i>Official-FR FB-4/17/21</i>			59.00
				<i>10 E 1500 3190 30 300 000003</i>			59.00
	Fitzgerald, Michael		59.00				
							123

Invoice Listing

COUNTY OF GRUNDY SCHOOL DIST 111

Full Name	PO Number	Invoice Number	Batch	Description	Invoice Date	Check Number	Net Amount
Flinn Scientific	1132100007	2548512	KAS	Lab Supplies	03/25/2021	082233	207.96
				<i>.1 M Silver nitrate Solution</i>			74.52
				<i>magnet wire</i>			6.44
				<i>Lab Kit - Leftover Aluminum Wire</i>			53.55
				<i>zinc strips</i>			24.30
				<i>Lead strips</i>			24.44
				<i>.1 M Copper (II) nitrate Solution</i>			10.82
				<i>.1 M Magnesium nitrate solution</i>			6.75
				<i>.1 M zinc nitrate solution</i>			7.14
				<i>10 E 1130 4100 13 300 000000</i>			74.52
				<i>10 E 1130 4100 13 300 000000</i>			6.44
				<i>10 E 1130 4100 13 300 000000</i>			53.55
				<i>10 E 1130 4100 13 300 000000</i>			24.30
				<i>10 E 1130 4100 13 300 000000</i>			24.44
				<i>10 E 1130 4100 13 300 000000</i>			10.82
				<i>10 E 1130 4100 13 300 000000</i>			6.75
				<i>10 E 1130 4100 13 300 000000</i>			7.14
Flinn Scientific			207.96				

124

Invoice Listing

COUNTY OF GRUNDY SCHOOL DIST 111

Full Name	PO Number	Invoice Number	Batch	Description	Invoice Date	Check Number	Net Amount
Follett School Solutions		785592	KAS	Books for Library	12/23/2020	082234	930.12
				<i>Books for Library</i>			930.12
				<i>10 E 2222 4300 00 300 000000</i>			930.12
Follett School Solutions		785592A	KAS	Books for Library	01/11/2021	082234	427.31
				<i>Books for Library</i>			427.31
				<i>10 E 2222 4300 00 300 000000</i>			427.31
Follett School Solutions Inc			1,357.43				
Frost, Kathy	1012100098	3/31/21 Piano	KAS	Chorus Piano Accompanist Hours	04/06/2021	9100000336	699.00 125
				<i>Chorus Piano Accompanist Hours</i>			699.00
				<i>10 E 1130 3000 12 300 000001</i>			699.00
Frost, Kathy			699.00				
Gerk, Olivia D		4/12/21 Custom Ink	KAS	Speech Team Award Shirts for end of the season from Custom Ink	04/12/2021	9100000362	308.99
				<i>Speech Team Award Shirts for end of</i>			308.99
				<i>10 E 1500 6400 70 300 000000</i>			308.99
Gerk, Olivia D			308.99				

Invoice Listing

COUNTY OF GRUNDY SCHOOL DIST 111

Full Name	PO Number	Invoice Number	Batch	Description	Invoice Date	Check Number	Net Amount
Gerkitz, Raymond	1032100127	23619 3/6/21	KAS	Girls Basketball-VAR-3-6-21	03/06/2021	082235	67.00
				<i>Girls Basketball-VAR-3-6-21</i>			67.00
				<i>10 E 1500 3190 30 300 000005</i>			67.00
Gerkitz, Raymond			67.00				
Glenbrook South High		2/28/21 Poms Dance	KAS	Poms Dance Challenge Virtual	02/28/2021	082236	200.00
				<i>Poms Dance Challenge Virtual</i>			200.00
				<i>10 E 1500 3900 30 300 000000</i>			200.00
Glenbrook South High School			200.00				
Gordon Food Service		208538729	KAS	Grocery	03/11/2021	082237	126 55.20
				<i>Grocery</i>			55.20
				<i>10 E 1420 1100 09 300 000000</i>			55.20
Gordon Food Service		208637720	KAS	Grocery	03/16/2021	082237	128.17
				<i>Grocery</i>			128.17
				<i>10 E 1420 4100 09 300 000000</i>			128.17
Gordon Food Service		208851927	KAS	Disposables	03/25/2021	082237	208.26
				<i>Disposables</i>			208.26
				<i>10 E 1420 4100 09 300 000000</i>			208.26

Invoice Listing

COUNTY OF GRUNDY SCHOOL DIST 111

Full Name	PO Number	Invoice Number	Batch	Description	Invoice Date	Check Number	Net Amount
Gordon Food Service		209161196	KAS	Grocery, Dairy	04/08/2021	082237	351.10
				<i>Grocery, Dairy</i>			<i>351.10</i>
				<i>10 E 1420 4100 09 300 000000</i>			<i>351.10</i>
Gordon Food Service		209267627	KAS	Frozen	04/13/2021	082374	176.26
				<i>Frozen</i>			<i>176.26</i>
				<i>10 E 1420 4100 09 300 000000</i>			<i>176.26</i>
Gordon Food Service		209425169	KAS	Grocery, Meat, Dairy, Disposables, Sanitation, Produce	04/20/2021	082374	406.80
				<i>Grocery, Meat, Dairy, Disposables,</i>			<i>406.80</i>
				<i>10 E 1420 4100 09 300 000000</i>			<i>406.80</i>
							127
							1,325.79
Gorecki, Abigail	1032100171	83433 4/6/21	KAS	Official-GVB-FR-4/6	04/04/2021	082375	88.00
				<i>Official-GVB-FR-4/6</i>			<i>88.00</i>
				<i>10 E 1500 3190 30 300 000000</i>			<i>88.00</i>
							88.00

Invoice Listing

COUNTY OF GRUNDY SCHOOL DIST 111

Full Name	PO Number	Invoice Number	Batch	Description	Invoice Date	Check Number	Net Amount
Grainger		9828899261	KAS	Eagle Util Sink Square, Drainboard 430SS	03/08/2021	082238	1,063.56
				<i>Eagle Util Sink Square</i>			897.60
				<i>Drainboard 430SS</i>			165.96
				<i>20 E 2540 3230 00 300 000000</i>			897.60
				<i>20 E 2540 3230 00 300 000000</i>			165.96
Grainger		9849521043	KAS	Coupling, Conduit Outlet, Elbow	03/26/2021	082238	52.32
				<i>Coupling 2 in. PVC</i>			2.17
				<i>Conduit Outlet Body PVC</i>			30.81
				<i>Elbow 90 Degree PVC</i>			19.34
				<i>20 E 2540 4100 00 300 000001</i>			2.17
				<i>20 E 2540 4100 00 300 000001</i>			30.81
				<i>20 E 2540 4100 00 300 000001</i>			19.34
Grainger		9853387083	KAS	Coupling 2 in. PVC	03/31/2021	082238	10.85
				<i>Coupling 2 in. PVC</i>			10.85
				<i>20 E 2540 4100 00 300 000001</i>			10.85

Invoice Listing

COUNTY OF GRUNDY SCHOOL DIST 111

Full Name	PO Number	Invoice Number	Batch	Description	Invoice Date	Check Number	Net Amount
Grainger		9867305733	KAS	Cable Coupler, Coaxial Cable	04/13/2021	082376	174.65
				<i>Cable Coupler</i>			<i>15.49</i>
				<i>Coaxial Cable</i>			<i>159.16</i>
				<i>20 E 2540 4100 00 300 000001</i>			<i>15.49</i>
				<i>20 E 2540 4100 00 300 000001</i>			<i>159.16</i>
Grainger			1,301.38				
Grawey-Beeler, Patricia		4/14/21 Walmart	KAS	Make-up and Supplies for Musical	04/06/2021	9100000363	95.15
				<i>Make-up and Supplies for Musical</i>			<i>95.15</i>
				<i>10 E 1500 4100 70 300 000004</i>			<i>129</i>
							<i>95.15</i>
Grawey-Beeler, Patricia E			95.15				
Grund, Brian	1032100152	84023 3/26/21	KAS	FB-SO-3-26	03/26/2021	082239	59.00
				<i>FB-SO-3-26</i>			<i>59.00</i>
				<i>10 E 1500 3190 30 300 000003</i>			<i>59.00</i>
Grund, Brian			59.00				

Invoice Listing

COUNTY OF GRUNDY SCHOOL DIST 111

Full Name	PO Number	Invoice Number	Batch	Description	Invoice Date	Check Number	Net Amount
Grundy Area Vocational		March-21	KAS	Ed and Building Fund Costs for March 2021	03/26/2021	082240	67,617.15
				<i>Ed Fund Costs for March 2021</i>			52,193.97
				<i>Building Fund Costs for March 2021</i>			15,423.18
				<i>10 E 4140 6000 00 000 000000</i>			52,193.97
				<i>20 E 4140 6000 00 000 000000</i>			15,423.18
Grundy Area Vocational Ctr			67,617.15				
Guisinger, Aaron	1032100179	84001 4/2/21	KAS	Official-FB-S-4/2/21	04/02/2021	082377	59.00
				<i>Official-FB-S-4/2/21</i>			59.00
				<i>10 E 1500 3190 30 300 000003</i>			59.00
Guisinger, Aaron			59.00				
Hanouw, Ken	1032100197	58981 4/10/21	KAS	Official-GVB-4/10/21	04/10/2021	082378	89.00
				<i>Official-GVB-4/10/21</i>			89.00
				<i>10 E 1500 3190 30 300 000000</i>			89.00
Hanouw, Ken	1032100224	58981 4/15/21	KAS	Official-JV/V GVB-4/15/21	04/15/2021	082378	89.00
				<i>Official-JV/V GVB-4/15/21</i>			89.00
				<i>10 E 1500 3190 30 300 000000</i>			89.00
Hanouw, Ken			178.00				

Invoice Listing

COUNTY OF GRUNDY SCHOOL DIST 111

Full Name	PO Number	Invoice Number	Batch	Description	Invoice Date	Check Number	Net Amount
Hauser Izzo Petrarca		27310	KAS	Legal Services - Property Taxes	02/28/2021	082241	897.00
				<i>Legal Services - Property Taxes</i>			897.00
				<i>80 E 2310 3180 00 300 000000</i>			897.00
Hauser Izzo Petrarca		27434	KAS	Legal Services - Property Taxes	03/31/2021	082241	92.00
				<i>Legal Services - Property Taxes</i>			92.00
				<i>80 E 2310 3180 00 300 000000</i>			92.00
Hauser Izzo Petrarca Gleason			989.00				
Head, Chris	1032100122	17233 3/6/21	KAS	Boys Basketball-FR-3-6-21	03/06/2021	082242	53.00
				<i>Boys Basketball-FR-3-6-21</i>			53.00
				<i>10 E 1500 3190 30 300 000004</i>			53.00
Head, Chris			53.00				
Held, Melinda Jane	1032100162	34081 3/30/21	KAS	GVB-3-30-21	03/30/2021	082243	89.00
				<i>GVB-3-30-21</i>			89.00
				<i>10 E 1500 3190 30 300 000000</i>			89.00
Held, Melinda Jane			89.00				

Invoice Listing

COUNTY OF GRUNDY SCHOOL DIST 111

Full Name	PO Number	Invoice Number	Batch	Description	Invoice Date	Check Number	Net Amount
Helm Mechanical / Helm		CHI181101	KAS	Piping for Outside Speakers on Bleachers	03/07/2021	082244	1,400.00
				<i>Piping for Outside Speakers on</i>			<i>1,400.00</i>
				<i>20 E 2540 4100 00 300 000001</i>			<i>1,400.00</i>
Helm Mechanical / Helm			1,400.00				
Hensley, Jr., Bobby	1032100141	63976 3/20/21	KAS	Football-FR-3-20-21	03/20/2021	082379	92.00
				<i>Football-FR-3-20-21</i>			<i>92.00</i>
				<i>10 E 1500 3190 30 300 000003</i>			<i>92.00</i>
Hensley, Jr., Bobby	1032100194	63976 4/10/21	KAS	Official-FB-FR-4/10/21	04/10/2021	082379	74.00 132
				<i>Official-FB-FR-4/10/21</i>			<i>74.00</i>
				<i>10 E 1500 3190 30 300 000003</i>			<i>74.00</i>
Hensley, Jr., Bobby			166.00				
Himes Petrarca Fester		44826	KAS	Legal Services through 3/31/21	04/01/2021	9100000337	282.50
				<i>Legal Services through 3/31/21</i>			<i>282.50</i>
				<i>80 E 2310 3180 00 300 000000</i>			<i>282.50</i>
Himes Petrarca Fester			282.50				

Invoice Listing

COUNTY OF GRUNDY SCHOOL DIST 111

Full Name	PO Number	Invoice Number	Batch	Description	Invoice Date	Check Number	Net Amount
Holmes, McLean A		4/14/21 Musical	KAS	Clear Masks for Musical from Amazon, reimbursement of food for picking up costumes and stage crew when stripping/painting stage floor from Jimmy John's and Dairy Queen	04/14/2021	082380	284.92
				<i>Clear Masks for Musical from Amazon,</i>			<i>284.92</i>
				<i>10 E 1500 4100 70 300 000004</i>			<i>284.92</i>
Holmes, McLean A			284.92				
Home Depot Credit		3511611	KAS	Woodshop Supplies	03/12/2021	082245	29.97
				<i>Woodshop Supplies</i>			<i>29.97</i>
				<i>10 E 1400 4100 10 300 000001</i>			<i>29.97</i>
Home Depot Credit		9623149, 4073196	KAS	Supplies for CTE and Groark	04/13/2021	082381	133 1,007.01
				<i>Supplies for CTE</i>			<i>283.46</i>
				<i>Supplies for Groark</i>			<i>723.55</i>
				<i>10 E 1400 4100 10 300 000001</i>			<i>283.46</i>
				<i>10 E 1400 4100 10 300 000001</i>			<i>723.55</i>
Home Depot Credit Services			1,036.98				
Horvath, Bob	1032100111	20654 3/8/21	KAS	Boys Basketball VAR-3-8-21	03/08/2021	082246	67.00
				<i>Boys Basketball VAR-3-8-21</i>			<i>67.00</i>
				<i>10 E 1500 3190 30 300 000004</i>			<i>67.00</i>
Horvath, Bob			67.00				

Invoice Listing

COUNTY OF GRUNDY SCHOOL DIST 111

Full Name	PO Number	Invoice Number	Batch	Description	Invoice Date	Check Number	Net Amount
Huey, Doug	1032100187	23673 4/1/21	KAS	Official-BSOC-V-4/1/21	04/01/2021	082382	65.00
				<i>Official-BSOC-V-4/1/21</i>			65.00
				<i>10 E 1500 3190 30 300 000001</i>			65.00
Huey, Doug			65.00				
Hughes, Howie	1032100120	33579 3/13/21	KAS	Football - 3-13-21	03/13/2021	082247	77.00
				<i>Football - 3-13-21</i>			77.00
				<i>10 E 1500 3190 30 300 000003</i>			77.00
Hughes, Howie			77.00				
IHSA - Illinois High		EF21-2144	KAS	IHSA Sports Fees 2020-21	03/11/2021	082248	900.00
				<i>IHSA Sports Fees 2020-21</i>			900.00
				<i>10 E 1500 3900 30 300 000001</i>			900.00
IHSA - Illinois High School			900.00				

134
900.00

Invoice Listing

COUNTY OF GRUNDY SCHOOL DIST 111

Full Name	PO Number	Invoice Number	Batch	Description	Invoice Date	Check Number	Net Amount
Illco		6170154	KAS	Start Capacitor, Relay, Overload	03/03/2021	082249	157.09
				<i>Start Capacitor</i>			27.97
				<i>Relay</i>			58.28
				<i>Relay</i>			35.58
				<i>Overload</i>			35.26
				<i>20 E 2540 4100 00 300 000000</i>			27.97
				<i>20 E 2540 4100 00 300 000000</i>			58.28
				<i>20 E 2540 4100 00 300 000000</i>			35.58
				<i>20 E 2540 4100 00 300 000000</i>			35.26
							135
Illco		6170527	KAS	Mc Taste Odor & Sediment Cartridge, No Rinse Evap Foam	03/17/2021	082249	203.77
				<i>Mc Taste Odor & Sediment Cartridge</i>			144.05
				<i>No Rinse Evap Foam</i>			59.72
				<i>20 E 2540 4100 00 300 000000</i>			144.05
				<i>20 E 2540 4100 00 300 000000</i>			59.72

Invoice Listing

COUNTY OF GRUNDY SCHOOL DIST 111

Full Name	PO Number	Invoice Number	Batch	Description	Invoice Date	Check Number	Net Amount
Illco		6171069	KAS	Control, Motor	04/08/2021	082383	178.87
				<i>Control</i>			94.35
				<i>Motor</i>			84.52
				<i>20 E 2540 4100 00 300 000000</i>			94.35
				<i>20 E 2540 4100 00 300 000000</i>			84.52
Illco		6171247	KAS	Float Valve, Float Ball	04/15/2021	082383	217.35
				<i>Float Valve</i>			129.24
				<i>Float Ball 5"</i>			88.11
				<i>20 E 2540 3000 00 302 000000</i>			129.24
				<i>20 E 2540 3000 00 302 000000</i>			88.11

Invoice Listing

COUNTY OF GRUNDY SCHOOL DIST 111

Full Name	PO Number	Invoice Number	Batch	Description	Invoice Date	Check Number	Net Amount
Illco		6171248	KAS	Press Ball Valve, Press, Press Old, Hard Copper Open End, Brass Bush	04/15/2021	082383	513.99
				<i>Press Ball Valve</i>			164.88
				<i>Press</i>			64.44
				<i>Press Old</i>			103.39
				<i>Hard Copper Open End</i>			112.00
				<i>Press Old</i>			69.28
				<i>20 E 2540 3000 00 302 000000</i>			164.88
				<i>20 E 2540 3000 00 302 000000</i>			64.44
				<i>20 E 2540 3000 00 302 000000</i>			103.39
				<i>20 E 2540 3000 00 302 000000</i>			112.00
				<i>20 E 2540 3000 00 302 000000</i>			69.28
Illco		6171280	KAS	Press, Press Old, Hard Copper Open End, T/PRV 3", Deburring Tool, Tubing Cutter, Brass Nip, Ball Valve	04/16/2021	082383	1,215.45
				<i>Press, Press Old, Hard Copper Open</i>			1,215.45
				<i>20 E 2540 4100 00 300 000000</i>			1,215.45
Illco			2,486.52				

Invoice Listing

COUNTY OF GRUNDY SCHOOL DIST 111

Full Name	PO Number	Invoice Number	Batch	Description	Invoice Date	Check Number	Net Amount
Illinois Office of the		9642520	KAS	Boiler Certificate Fee and State Inspection Fee	03/16/2021	082250	100.00
				<i>Boiler Certificate Fee</i>			<i>70.00</i>
				<i>Boiler State Inspection Fee</i>			<i>30.00</i>
				<i>20 E 2540 5400 00 302 000000</i>			<i>70.00</i>
				<i>20 E 2540 5400 00 302 000000</i>			<i>30.00</i>
Illinois Office of the State Fire			100.00				
Illinois Prep Top Timing		030321	KAS	Fat Timing 4/20, 5/11, 5/21, 5/25/21	03/03/2021	082251	3,300.00
				<i>Fat Timing 4/20/21</i>			<i>700.00</i>
				<i>Fat Timing 5/11/21</i>			<i>700.00</i>
				<i>Fat Timing 5/21/21</i>			<i>1,200.00</i>
				<i>Fat Timing 5/25/21</i>			<i>700.00</i>
				<i>10 E 1500 3900 30 300 000001</i>			<i>700.00</i>
				<i>10 E 1500 3900 30 300 000001</i>			<i>700.00</i>
				<i>10 E 1500 3900 30 300 000001</i>			<i>1,200.00</i>
				<i>10 E 1500 3900 30 300 000001</i>			<i>700.00</i>
Illinois Prep Top Timing			3,300.00				

Invoice Listing

COUNTY OF GRUNDY SCHOOL DIST 111

Full Name	PO Number	Invoice Number	Batch	Description	Invoice Date	Check Number	Net Amount
Illinois Public Risk Fund		65312	KAS	May 2021 Workers' Compensation, Administrative Fee	03/15/2021	082252	13,693.00
				<i>May 2021 Workers' Compensation</i>			<i>13,293.00</i>
				<i>May 2021 Administrative Fee</i>			<i>400.00</i>
				<i>80 E 2362 3800 00 300 000000</i>			<i>13,293.00</i>
				<i>80 E 2362 3800 00 300 000000</i>			<i>400.00</i>
Illinois Public Risk Fund			13,693.00				
Illinois Tollway		VN5902478285	KAS	Vehicle Plate 103903SB Unpaid Tolls, Invoice Fee	04/09/2021	082384	30.40
				<i>Vehicle Plate 103903SB Unpaid Tolls</i>			<i>10.40</i>
				<i>Vehicle Plate 103903SB Invoice Fee</i>			<i>20.00</i>
				<i>40 E 2550 6400 00 000 000000</i>			<i>10.40</i>
				<i>40 E 2550 6400 00 000 000000</i>			<i>20.00</i>
Illinois Tollway			30.40				
Image Systems &		M0316A21	KAS	Color Laser Gloss Paper, Astrobrights Colored Card Stock	03/19/2021	082253	356.30
				<i>Color Laser Gloss Paper</i>			<i>162.50</i>
				<i>Astrobrights Colored Card Stock</i>			<i>193.80</i>
				<i>10 E 2632 4100 00 300 000000</i>			<i>162.50</i>
				<i>10 E 2632 4100 00 300 000000</i>			<i>193.80</i>
Image Systems & Business			356.30				

Invoice Listing

COUNTY OF GRUNDY SCHOOL DIST 111

Full Name	PO Number	Invoice Number	Batch	Description	Invoice Date	Check Number	Net Amount
Instrumentalist Awards		2101	KAS	Sousa/Conductors, Choral, Jazz, L Bernstein Awards	03/15/2021	082254	259.00
				<i>Sousa/Conductors Award</i>			70.00
				<i>Choral Award</i>			61.00
				<i>Jazz Award</i>			61.00
				<i>L Bernstein Award</i>			67.00
				<i>10 E 1130 5400 12 300 000000</i>			70.00
				<i>10 E 1130 5400 12 300 000000</i>			61.00
				<i>10 E 1130 5400 12 300 000000</i>			61.00
				<i>10 E 1130 5400 12 300 000000</i>			67.00
							140
Instrumentalist Awards			259.00				
ITR Systems - Division		102143	KAS	Sound System for Football Stadium, Digital Wireless Headset Microphone System	03/18/2021	082255	33,425.00
				<i>Sound System for Football Stadium</i>			29,475.00
				<i>Digital Wireless Headset Microphone</i>			3,950.00
				<i>20 E 2540 5400 00 300 000000</i>			29,475.00
				<i>20 E 2540 5400 00 300 000000</i>			3,950.00
ITR Systems - Division		102212	KAS	Service on Intercom System	04/06/2021	082255	3,165.30
				<i>Service on Intercom System</i>			3,165.30
				<i>20 E 2540 3230 00 300 000000</i>			3,165.30

Invoice Listing

COUNTY OF GRUNDY SCHOOL DIST 111

Full Name	PO Number	Invoice Number	Batch	Description	Invoice Date	Check Number	Net Amount
ITR Systems - Division		102314	KAS	Service on Intercom System	04/21/2021	082385	345.30
				<i>Service on Intercom System</i>			345.30
				<i>10 E 2225 3000 00 300 000000</i>			345.30
ITR Systems - Division of			36,935.60				
J.W. Pepper	1012100069	363275913	KAS	Chorus music	03/05/2021	9100000338	71.98
				<i>Chorus Music</i>			71.98
				<i>10 E 1130 4100 12 300 000001</i>			71.98
J.W. Pepper	1012100069	363277170	KAS	Chorus music	03/05/2021	9100000338	355.95
				<i>Chorus Music</i>			355.95
				<i>10 E 1130 4100 12 300 000001</i>			355.95
J.W. Pepper			427.93				
Jerrys Glass & Lock		40682	KAS	Repair glass in door	03/16/2021	082256	100.00
				<i>Repair glass in door</i>			100.00
				<i>20 E 2540 3230 00 302 000000</i>			100.00
Jerrys Glass & Lock			100.00				

Invoice Listing

COUNTY OF GRUNDY SCHOOL DIST 111

Full Name	PO Number	Invoice Number	Batch	Description	Invoice Date	Check Number	Net Amount
Johnstone, Hannah		4/13/21 Party City	KAS	Decorations and supplies, Disneylap for NHS Walk for a Cure	04/13/2021	082386	82.47
				<i>Decorations and supplies, Disneylap for</i>			82.47
				<i>10 E 1500 4100 70 300 000003</i>			82.47
Johnstone, Hannah			82.47				
Joliet West High School		3/11/21 Bowling Boys	KAS	Boys JV Bowling Tournament	03/11/2021	082257	100.00
				<i>Boys JV Bowling Tournament</i>			100.00
				<i>10 E 1500 3900 30 300 000000</i>			100.00
Joliet West High School			100.00				
Jones III, Robert	1032100142	86863 3/20/21	KAS	Football-FR A&B -3/20/21	03/20/2021	082258	142 92.00
				<i>Football FR A&B - 3/20/21</i>			92.00
				<i>10 E 1500 3190 30 300 000003</i>			92.00
Jones III, Robert	1032100195	86863 4/10/21	KAS	Official-FB-FR-4/10/21	04/10/2021	082387	74.00
				<i>Official-FB-FR-4/10/21</i>			74.00
				<i>10 E 1500 3190 30 300 000003</i>			74.00
Jones III, Robert			166.00				

Invoice Listing

COUNTY OF GRUNDY SCHOOL DIST 111

Full Name	PO Number	Invoice Number	Batch	Description	Invoice Date	Check Number	Net Amount
Jostens		25829860	KAS	Diploma	03/15/2021	082259	2,621.35
				<i>Diploma</i>			2,621.35
				<i>10 E 2410 4100 00 300 000002</i>			2,621.35
Jostens		25943316	KAS	Certificate of Attendance	03/25/2021	082259	14.29
				<i>Certificate of Attendance</i>			14.29
				<i>10 E 2410 4100 00 300 000002</i>			14.29
Jostens		26187450	KAS	Cord in Gold, Orange, Purple, Silver Gray	04/15/2021	082388	1,369.32
							143
				<i>Cord in Gold, Orange, Purple, Silver</i>			1,369.32
				<i>10 E 2410 4100 00 300 000002</i>			1,369.32
Jostens			4,004.96				

Invoice Listing

COUNTY OF GRUNDY SCHOOL DIST 111

Full Name	PO Number	Invoice Number	Batch	Description	Invoice Date	Check Number	Net Amount
Kennicott Brothers		501960705	KAS	Carnation, Cushion Maisy White, Daisy Atlantis Lavender, Hydranea, Limonium Misty Blue	04/12/2021	082389	178.53
				<i>Carnation Assorted</i>			68.75
				<i>Cushion Maisy White</i>			22.50
				<i>Daisy Atlantis Lavender</i>			22.50
				<i>Hydranea Assorted</i>			7.80
				<i>Limonium Misty Blue</i>			56.98
				<i>10 E 1401 4100 01 300 000000</i>			68.75
				<i>10 E 1401 4100 01 300 000000</i>			22.50
				<i>10 E 1401 4100 01 300 000000</i>			22.50
				<i>10 E 1401 4100 01 300 000000</i>			7.80
				<i>10 E 1401 4100 01 300 000000</i>			56.98
Kennicott Brothers			178.53				
Kiefer, Timothy	1032100183	18338 4/2/21	KAS	Official-FB-V-4/2/21	04/02/2021	082390	77.00
				<i>Official-FB-V-4/2/21</i>			77.00
				<i>10 E 1500 3190 30 300 000003</i>			77.00
Kiefer, Timothy			77.00				

Invoice Listing

COUNTY OF GRUNDY SCHOOL DIST 111

Full Name	PO Number	Invoice Number	Batch	Description	Invoice Date	Check Number	Net Amount
Kimball Midwest		8768395	KAS	Building Supplies - Central, South	04/01/2021	082391	3,009.21
				<i>Building Supplies - Central</i>			1,504.61
				<i>Building Supplies - South</i>			1,504.60
				<i>20 E 2540 4100 00 300 000000</i>			1,504.61
				<i>20 E 2540 4100 00 300 000000</i>			1,504.60
	Kimball Midwest		3,009.21				
Knapp, Robert	1032100154	65880 3/26/21	KAS	FB-VAR-3-26	03/26/2021	082260	77.00
				<i>FB-VAR-3-26</i>			77.00
				<i>10 E 1500 3190 30 300 000003</i>			77.00
	Knapp, Robert		77.00				
Kruse, Shelly L		2/24/21 Walmart	KAS	Fabric and ingredients for FACS/CTE programs from Walmart	02/24/2021	9100000339	45.00
				<i>Fabric and ingredients for FACS/CTE</i>			45.00
				<i>10 E 1420 4100 09 300 000000</i>			45.00
	Kruse, Shelly L		45.00				
Kruswicki, John	1032100041	57522 2/9/21	KAS	2/9/21 Basketball-Boys Var Official	02/09/2021	082261	67.00
				<i>2/9/21 Basketball - Boys Var Official</i>			67.00
				<i>10 E 1500 3190 30 300 000004</i>			67.00
	Kruswicki, John		67.00				

Invoice Listing

COUNTY OF GRUNDY SCHOOL DIST 111

Full Name	PO Number	Invoice Number	Batch	Description	Invoice Date	Check Number	Net Amount
Kwasny, Tracy A		2008158 538.00	KAS	REAL 694 Strategies to Support Blended Learning - Univ. of St. Francis	04/13/2021	9100000364	555.00
				<i>REAL 694 Strategies to Support Blended</i>			555.00
				<i>10 E 1130 2300 00 300 000000</i>			555.00
Kwasny, Tracy A			555.00				
Laforce	1122100023	1157311	KAS	Physical Education Student Padlocks Please use the address below for Payment LAFORCE 7501 S. Quincy St. Willowbrook, IL 630-325-1950	03/23/2021	9100000340	3,035.00
				<i>American Lock A400K- Blue Padlock</i>			2,800.00
				<i>American Lock A400Key-960</i>			195.00
				<i>Shipping</i>			40.00
				<i>10 E 1130 4000 50 300 000000</i>			2,800.00
				<i>10 E 1130 4000 50 300 000000</i>			195.00
				<i>10 E 1130 4000 50 300 000000</i>			40.00
Laforce			3,035.00				
Lee, Kenneth C		3/21 Mileage	KAS	Mileage for March 2021	03/25/2021	9100000341	57.68
				<i>Mileage for March 2021</i>			57.68
				<i>10 E 2321 3320 00 300 000001</i>			57.68

Invoice Listing

COUNTY OF GRUNDY SCHOOL DIST 111

Full Name	PO Number	Invoice Number	Batch	Description	Invoice Date	Check Number	Net Amount
Lee, Kenneth C		4/21 Phone	KAS	Phone Reimbursement for 4/21	04/01/2021	9100000341	100.00
				<i>Phone Reimbursement for 4/21</i>			<i>100.00</i>
				<i>20 E 2540 3400 00 300 000001</i>			<i>100.00</i>
Lee, Kenneth C			157.68				
Lincoln-Way East High		1/27/21 Cheerleading	KAS	Cheerleading"North Pole" Invitational - 2 teams	01/27/2021	082262	400.00
				<i>Cheerleading"North Pole" Invitational - 2</i>			<i>400.00</i>
				<i>10 E 1500 3900 30 300 000000</i>			<i>400.00</i>
Lincoln-Way East High			400.00				
Lopez, Raul	1032100178	60898 4/2/21	KAS	Official-FB-S-4/2/21	04/02/2021	082392	147 59.00
				<i>Official-FB-S-4/2/21</i>			<i>59.00</i>
				<i>10 E 1500 3190 30 300 000003</i>			<i>59.00</i>
Lopez, Raul			59.00				
Lucas, Tim	1032100131	36182 3/13/21	KAS	Football-Var-3-13-21	03/13/2021	082263	77.00
				<i>Football-Var-3-13-21</i>			<i>77.00</i>
				<i>10 E 1500 3190 30 300 000003</i>			<i>77.00</i>
Lucas, Tim			77.00				

Invoice Listing

COUNTY OF GRUNDY SCHOOL DIST 111

Full Name	PO Number	Invoice Number	Batch	Description	Invoice Date	Check Number	Net Amount
Lyons, Amy J		2008161 537.00	KAS	REAL 694G Strategies to support Blended Learning - Univ. of St. Francis	04/12/2021	9100000365	555.00
				<i>REAL 694G Strategies to support</i>			555.00
				<i>10 E 1130 2300 00 300 000000</i>			555.00
	Lyons, Amy J		555.00				
Lyons, Keith	1032100155	47544 3/26/21	KAS	FB-VAR-3-26	03/26/2021	082264	77.00
				<i>FB-VAR-3-26</i>			77.00
				<i>10 E 1500 3190 30 300 000003</i>			77.00
	Lyons, Keith		77.00				
Lyons, Michael	1032100105	82485 3/5/21	KAS	Boys Basketball So-3-5-21	03/05/2021	082265	148 53.00
				<i>Boys Basketball So-3-5-21</i>			53.00
				<i>10 E 1500 3190 30 300 000004</i>			53.00
	Lyons, Michael		53.00				
Majchrowski, Stacy	1032100112	72764 3/8/21	KAS	Girls Basketball VAR-3-8-21	03/08/2021	082266	67.00
				<i>Girls Basketball VAR-3-8-21</i>			67.00
				<i>10 E 1500 3190 30 300 000005</i>			67.00
	Majchrowski, Stacy		67.00				

Invoice Listing

COUNTY OF GRUNDY SCHOOL DIST 111

Full Name	PO Number	Invoice Number	Batch	Description	Invoice Date	Check Number	Net Amount
Makerbot Industries	1092100031	INV91850342	KAS	Filament for 3D Printers	03/29/2021	082267	494.00
				<i>Filament for 3d Printer for PLTW</i>			494.00
				<i>10 E 1400 4100 10 300 000001</i>			494.00
Makerbot Industries		INV91851396	KAS	Filament for 3D Printers	04/20/2021	082393	468.00
				<i>Filament for 3D Printers</i>			468.00
				<i>10 E 1400 4100 10 300 000001</i>			468.00
Makerbot Industries			962.00				
Malone, Dan	1032100132	32051 3/6/21	KAS	Girls Basketball-JV-3-6-21	03/06/2021	082268	53.00
				<i>Football-Var-3-13-21</i>			53.00
				<i>10 E 1500 3190 30 300 000005</i>			53.00
Malone, Dan			53.00				
Marchese, Steven	1032100157	60427 3/26/21	KAS	FB-VAR-3/26	03/26/2021	082269	77.00
				<i>FB-VAR-3/26</i>			77.00
				<i>10 E 1500 3190 30 300 000003</i>			77.00
Marchese, Steven			77.00				

Invoice Listing

COUNTY OF GRUNDY SCHOOL DIST 111

Full Name	PO Number	Invoice Number	Batch	Description	Invoice Date	Check Number	Net Amount
Marginean, Dan	1032100129	65253 3/9/21	KAS	Boys Soccer-JV-3-9-21	03/09/2021	082270	61.00
				<i>Boys Soccer-JV-3-9-21</i>			<i>61.00</i>
				<i>10 E 1500 3190 30 300 000001</i>			<i>61.00</i>
Marginean, Dan	1032100169	65253 4-1-21	KAS	BSOC-JV-4/1	04/01/2021	082270	61.00
				<i>BSOC-JV-4/1</i>			<i>61.00</i>
				<i>10 E 1500 3190 30 300 000001</i>			<i>61.00</i>
Marginean, Dan			122.00				
Mark, Jaqueline	1032100163	59154 3/30/21	KAS	GVB-3-30-21 *Note Address change - 305 Derby Ct. Wilmington, IL 60481	03/30/2021	082271	89.00 150
				<i>GVB-3-30-21</i>			<i>89.00</i>
				<i>10 E 1500 3190 30 300 000000</i>			<i>89.00</i>
Mark, Jaqueline			89.00				
Marron, Neil	1032100191	48077 4/9/21	KAS	Official-GVB-4-9-21	04/09/2021	082394	89.00
				<i>Official-GVB-4-9-21</i>			<i>89.00</i>
				<i>10 E 1500 3190 30 300 000000</i>			<i>89.00</i>
Marron, Neil			89.00				

Invoice Listing

COUNTY OF GRUNDY SCHOOL DIST 111

Full Name	PO Number	Invoice Number	Batch	Description	Invoice Date	Check Number	Net Amount
Matuszewski, Allen	1032100108	73953 3/5/21	KAS	Boys Basketball VAR-3-5-21	03/05/2021	082272	67.00
				<i>Boys Basketball VAR-3-5-21</i>			67.00
				<i>10 E 1500 3190 30 300 000004</i>			67.00
Matuszewski, Allen			67.00				
Matuszewski, Gregory	1032100123	25628 3/6/21	KAS	Boys Basketball-FR-3-6-21	03/06/2021	082273	53.00
				<i>Boys Basketball-FR-3-6-21</i>			53.00
				<i>10 E 1500 3190 30 300 000004</i>			53.00
Matuszewski, Gregory			53.00				
McCammack, Devan	1032100160	85273 3/29/21	KAS	Boys Soccer-VAR-3/29/21	03/29/2021	082274	151 65.00
				<i>Boys Soccer-VAR-3/29/21</i>			65.00
				<i>10 E 1500 3190 30 300 000001</i>			65.00
McCammack, Devan	1032100165	85273 3/31/21	KAS	BSOC-FR 3-31-21	03/31/2021	082274	61.00
				<i>BSOC-FR 3-31-21</i>			61.00
				<i>10 E 1500 3190 30 300 000001</i>			61.00

Invoice Listing

COUNTY OF GRUNDY SCHOOL DIST 111

Full Name	PO Number	Invoice Number	Batch	Description	Invoice Date	Check Number	Net Amount
McCammack, Devan	1032100257	85273 4/26/21	KAS	Official-GSOC-V-4/26/21	04/26/2021	082395	65.00
				<i>Official-GSOC-V-4/26/21</i>			65.00
				<i>10 E 1500 3190 30 300 000012</i>			65.00
McCammack, Devan			191.00				
McDermott, Mike	1032100137	52466 3/19/21	KAS	Boys Soccer - FR - 3-19-21	03/19/2021	082275	61.00
				<i>Boys Soccer - FR - 3-19-21</i>			61.00
				<i>10 E 1500 3190 30 300 000001</i>			61.00
McDermott, Mike			61.00				
McKillip, Donald	1032100193	51586 4/9/21	KAS	Official-GVB-4-9-21	04/09/2021	082396	152 88.00
				<i>Official-GVB-4-9-21</i>			88.00
				<i>10 E 1500 3190 30 300 000000</i>			88.00
McKillip, Donald	1032100198	51586 4/10/21	KAS	Official-GVB-4/10/21	04/10/2021	082396	89.00
				<i>Official-GVB-4/10/21</i>			89.00
				<i>10 E 1500 3190 30 300 000000</i>			89.00

Invoice Listing

COUNTY OF GRUNDY SCHOOL DIST 111

Full Name	PO Number	Invoice Number	Batch	Description	Invoice Date	Check Number	Net Amount
McKillip, Donald	1032100240	51586 4/24/21	KAS	Official-GVB-4/24/21	04/24/2021	082396	56.00
				<i>Official-GVB-4/24/21</i>			56.00
				<i>10 E 1500 3190 30 300 000000</i>			56.00
McKillip, Donald			233.00				
McKinley Woods Road		Apr. 2021 Lease	KAS	Monthly Lease for Project Indian - April 2021	04/01/2021	9100000342	1,660.80
				<i>Monthly Lease for Project Indian - April</i>			1,660.80
				<i>20 E 2540 3200 00 301 000000</i>			1,660.80
McKinley Woods Road			1,660.80				
Meadows, Katie M		3/28/21 Comprehended	KAS	Comprehended Online Conference 3/28 to 6/28/21	04/16/2021	9100000366	153 179.00
				<i>Comprehended Online Conference 3/28</i>			179.00
				<i>10 E 2210 3000 06 300 000000</i>			179.00
Meadows, Katie M			179.00				
Menards		45877	KAS	Supplies for Guys and Dolls	03/28/2021	082276	79.20
				<i>Supplies for Guys and Dolls</i>			79.20
				<i>10 E 1500 4100 70 300 000004</i>			79.20

Invoice Listing

COUNTY OF GRUNDY SCHOOL DIST 111

Full Name	PO Number	Invoice Number	Batch	Description	Invoice Date	Check Number	Net Amount
Menards		48025	KAS	Supplies for Guys and Dolls	03/19/2021	082276	73.77
				<i>Supplies for Guys and Dolls</i>			73.77
				<i>10 E 1500 4100 70 300 000004</i>			73.77
Menards		48844	KAS	Industrial Tech Supplies	04/01/2021	082276	44.85
				<i>Industrial Tech Supplies</i>			44.85
				<i>10 E 1400 4100 10 300 000001</i>			44.85
Menards		48884	KAS	Supplies for Stage	04/02/2021	082276	78.08
				<i>Supplies for Stage</i>			78.08
				<i>10 E 1500 4100 70 300 000004</i>			78.08
Menards			275.90				
Messina, Chris	1032100144	58722 3/25/21	KAS	BSOC-V-3/25/21	03/25/2021	082277	65.00
				<i>BSOC-V-3/25/21</i>			65.00
				<i>10 E 1500 3190 30 300 000001</i>			65.00
Messina, Chris			65.00				

Invoice Listing

COUNTY OF GRUNDY SCHOOL DIST 111

Full Name	PO Number	Invoice Number	Batch	Description	Invoice Date	Check Number	Net Amount
Meyer Laboratory, Inc.		0776509-IN	KAS	Lambswool Duster, Extendable Lambs, Deluxe Heavy Duty, 4" Replacement, Perlex Light, Perfex Heavy, Perfex Handles	03/11/2021	082278	417.60
				<i>Lambswool Duster</i>			31.32
				<i>Extendable Lambs</i>			35.04
				<i>Deluxe Heavy Duty</i>			52.50
				<i>4" Replacement</i>			41.16
				<i>Perlex Light</i>			57.90
				<i>Perfex Heavy</i>			57.90
				<i>Perfex Handles</i>			141.78
				<i>20 E 2540 4100 00 300 000000</i>			31.32
				<i>20 E 2540 4100 00 300 000000</i>			35.04
				<i>20 E 2540 4100 00 300 000000</i>			52.50
				<i>20 E 2540 4100 00 300 000000</i>			41.16
				<i>20 E 2540 4100 00 300 000000</i>			57.90
				<i>20 E 2540 4100 00 300 000000</i>			57.90
				<i>20 E 2540 4100 00 300 000000</i>			141.78
Meyer Laboratory, Inc.			417.60				

Invoice Listing

COUNTY OF GRUNDY SCHOOL DIST 111

Full Name	PO Number	Invoice Number	Batch	Description	Invoice Date	Check Number	Net Amount
Micetich, Nick		2014365 552.00	KAS	ED5303 Principles of Human Learning, HLTH5443 Technology, Leadership, and Health Informatics - American College of Education	02/19/2021	9100000367	1,110.00
				<i>ED5303 Principles of Human Learning</i>			555.00
				<i>HLTH5443 Technology, Leadership, and</i>			555.00
				<i>10 E 1130 2300 00 300 000000</i>			555.00
				<i>10 E 1130 2300 00 300 000000</i>			555.00
Micetich, Nick			1,110.00				
Midwest Bus Sales		C050047207.01	KAS	Light, Stop tail turn red	03/09/2021	082279	125.63
				<i>Light, Stop tail turn red</i>			125.63
				<i>40 E 2554 3230 00 300 000000</i>			125.63
Midwest Bus Sales		Co50047512.01	KAS	Mirror, Crossview C2 w/Harness	03/31/2021	082397	127.78
				<i>Mirror, Crossview C2 w/Harness</i>			127.78
				<i>40 E 2554 3230 00 300 000000</i>			127.78
Midwest Bus Sales			253.41				
Milnes, Erik R		114-5361516-6420206	KAS	Supplies for Sensory Therapy from Amazon	03/08/2021	9100000343	74.79
				<i>Supplies for Sensory Therapy from</i>			74.79
				<i>10 E 1200 4100 00 300 000002</i>			74.79
Milnes, Erik R			74.79				

Invoice Listing

COUNTY OF GRUNDY SCHOOL DIST 111

Full Name	PO Number	Invoice Number	Batch	Description	Invoice Date	Check Number	Net Amount
Minooka CCSD #201		130	KAS	Share of Bus Garage costs for March 2021	04/12/2021	082398	9,487.80
				<i>AT&T 815R17-02614960</i>			9.06
				<i>Call One #390789</i>			29.50
				<i>Cross Points Sales #43136</i>			75.00
				<i>Cross Points Sales #21093</i>			155.00
				<i>Correct Electric #21150</i>			136.70
				<i>Dynegy #1459122092</i>			582.61
				<i>Gordon Flesch #13267997</i>			25.88
				<i>KCG Management #75684 Plowing, salt</i>			1,810.50
				<i>KCG Management #75693 Plowing, salt</i>			691.25
				<i>KCG Management #75733 Plowing, salt</i>			1,570.00
				<i>KCG Management #75753 Plowing, salt</i>			691.25
				<i>KCG Management #75754 Plowing, salt</i>			1,252.50
				<i>Nelson Fire Protection Co. #23565</i>			291.25
				<i>Nicor Gas 84-80-23-41705</i>			1,386.83
				<i>Quench #02994577</i>			30.00
				<i>Waste Management #6167181-2007-7</i>			506.36
				<i>Uline #52272599</i>			244.11
				<i>40 E 2550 3400 00 300 000000</i>			9.06

157

Invoice Listing

COUNTY OF GRUNDY SCHOOL DIST 111

Full Name	PO Number	Invoice Number	Batch	Description	Invoice Date	Check Number	Net Amount
				40 E 2550 3400 00 300 000000			29.50
				40 E 2554 3230 00 300 000000			75.00
				40 E 2554 3230 00 300 000000			155.00
				40 E 2554 3000 00 300 000000			136.70
				40 E 2552 4660 00 300 000000			582.61
				40 E 2554 3000 00 300 000000			25.88
				40 E 2550 3220 00 300 000001			1,810.50
				40 E 2550 3220 00 300 000001			691.25
				40 E 2550 3220 00 300 000001			1,570.00
				40 E 2550 3220 00 300 000001			691.25
				40 E 2550 3220 00 300 000001			1,252.50
				80 E 2365 3900 00 300 000002			291.25
				40 E 2552 4650 00 300 000000			1,386.83
				40 E 2550 3700 00 300 000000			30.00
				40 E 2550 3210 00 300 000000			506.36
				40 E 2552 4100 00 300 000000			244.11
	Minooka CCSD #201						9,487.80

158

Invoice Listing

COUNTY OF GRUNDY SCHOOL DIST 111

Full Name	PO Number	Invoice Number	Batch	Description	Invoice Date	Check Number	Net Amount
Minooka Grade School		3/26/21 Long	KAS	Wendy Long Salary and Benefits - Jan. 1 thru Mar. 31, 2021	03/26/2021	9100000344	4,334.82
				<i>Long Salary</i>		3,233.41	
				<i>Long FICA</i>		247.35	
				<i>Long IMRF</i>		281.06	
				<i>Long Insurance</i>		573.00	
				40 E 2550 1100 00 300 000000		3,233.41	
				50 E 2554 2130 00 300 000000		247.35	
				50 E 2554 2120 00 300 000000		281.06	
				40 E 2554 2220 00 300 000000		573.00	159
Minooka Grade School		3/26/21 Tilghman	KAS	Aurora Tilghman Salary and Benefits - Jan. 1 thru Mar. 31, 2021	04/26/2021	9100000344	3,190.41
				<i>Tilgham Salary</i>		2,738.88	
				<i>Tilghman FICA</i>		209.53	
				<i>Tilghman IMRF</i>		239.93	
				<i>Tilghman Insurance</i>		2.07	
				40 E 2550 1100 00 300 000000		2,738.88	
				50 E 2554 2130 00 300 000000		209.53	
				50 E 2554 2120 00 300 000000		239.93	
				40 E 2554 2220 00 300 000000		2.07	
Minooka Grade School			7,525.23				

Invoice Listing

COUNTY OF GRUNDY SCHOOL DIST 111

Full Name	PO Number	Invoice Number	Batch	Description	Invoice Date	Check Number	Net Amount
Morgan, Jenny A		2008079 530.00	KAS	REAL694G Strategies to Support Blended Learning	04/07/2021	9100000368	555.00
				<i>REAL694G Strategies to Support</i>			555.00
				<i>10 E 1130 2300 00 300 000000</i>			555.00
Morgan, Jenny A			555.00				
Moroney, Joseph	1032100147	15198 3/25/21	KAS	Boys Soccer - JV - 3/25/21	03/25/2021	082280	61.00
				<i>Boys Soccer - JV - 3/25/21</i>			61.00
				<i>10 E 1500 3190 30 300 000001</i>			61.00
Moroney, Joseph			61.00				
Morris Community High		2020-21 Boys Swimming	KAS	Boys Swim Participants 2020-21 Season	03/29/2021	082281	9,320.00
				<i>Boys Swim Participants 2020-21 Season</i>			9,320.00
				<i>10 E 1500 3000 30 300 000023</i>			9,320.00
Morris Community High			9,320.00				
Motykowski, Mark	1032100199	80862 4/10/21	KAS	Official-GVB-4/10/21	04/10/2021	082399	88.00
				<i>Official-GVB-4/10/21</i>			88.00
				<i>10 E 1500 3190 30 300 000000</i>			88.00
Motykowski, Mark			88.00				

Invoice Listing

COUNTY OF GRUNDY SCHOOL DIST 111

Full Name	PO Number	Invoice Number	Batch	Description	Invoice Date	Check Number	Net Amount
Munns, Marty	1032100130	33814 3/13/21	KAS	Football-Var-3-13-21	03/13/2021	082282	77.00
				<i>Football-Var-3-13-21</i>			77.00
				<i>10 E 1500 3190 30 300 000003</i>			77.00
Munns, Marty			77.00				
Murzyn, Gary	1032100175	21692 4/6/21	KAS	Official-GVB-V/JV-4-6-21	04/06/2021	082400	89.00
				<i>Official-GVB-V/JV-4-6-21</i>			89.00
				<i>10 E 1500 3190 30 300 000000</i>			89.00
Murzyn, Gary			89.00				
Napa Auto Parts		104156	KAS	Belt - Serpentine	03/08/2021	082283	161 41.13
				<i>Belt - Serpentine</i>			41.13
				<i>40 E 2554 3230 00 300 000000</i>			41.13
Napa Auto Parts		104393	KAS	V-Belt	03/12/2021	082283	95.14
				<i>V-Belt</i>			95.14
				<i>40 E 2554 3230 00 300 000000</i>			95.14
Napa Auto Parts		104821	KAS	Oil Fil	03/23/2021	082283	32.74
				<i>Oil Fil</i>			32.74
				<i>40 E 2554 3230 00 300 000000</i>			32.74

Invoice Listing

COUNTY OF GRUNDY SCHOOL DIST 111

Full Name	PO Number	Invoice Number	Batch	Description	Invoice Date	Check Number	Net Amount
Napa Auto Parts		105100	KAS	Wiper Blades	03/30/2021	082283	29.96
				<i>Wiper Blades</i>			29.96
				<i>40 E 2554 3230 00 300 000000</i>			29.96
Napa Auto Parts		105749	KAS	Battery, Core Deposit	04/14/2021	082401	140.99
				<i>Battery</i>			122.99
				<i>Core Deposit</i>			18.00
				<i>40 E 2554 3230 00 300 000000</i>			122.99
				<i>40 E 2554 3230 00 300 000000</i>			18.00
Napa Auto Parts		106190	KAS	Quality Htr/Hose	04/26/2021	082401	55.86
				<i>Quality Htr/Hose</i>			55.86
				<i>40 E 2554 3230 00 300 000000</i>			55.86
Napa Auto Parts			395.82				
Narayan, Rabindra	1032100115	34196 3/9/21	KAS	Boys Soccer-Var-3-9-21	03/09/2021	082284	65.00
				<i>Boys Soccer-Var-3-9-21</i>			65.00
				<i>10 E 1500 3190 30 300 000001</i>			65.00
Narayan, Rabindra			65.00				

Invoice Listing

COUNTY OF GRUNDY SCHOOL DIST 111

Full Name	PO Number	Invoice Number	Batch	Description	Invoice Date	Check Number	Net Amount
Neff		N002862778	KAS	Plaque Award Senior Band, Qualifying Plates	07/13/2020	082402	637.56
				<i>Plaque Award Senior Band, Qualifying</i>			637.56
				<i>10 E 1130 5400 12 300 000000</i>			637.56
Neff			637.56				
Nevsimal, Kevin	1012100087	3/20/21 Drill Design	KAS	Drill writing for Marching Band, In the Stone - first installment	03/20/2021	082285	1,500.00
				<i>Drill writing for Marching Band, In the</i>			1,500.00
				<i>10 E 1130 3000 12 300 000000</i>			1,500.00
Nevsimal, Kevin			1,500.00				
Newberry, Larry	1032100119	24859 3/13/21	KAS	Football - 3-13-21	03/13/2021	082286	163 77.00
				<i>Football - 3-13-21</i>			77.00
				<i>10 E 1500 3190 30 300 000003</i>			77.00
Newberry, Larry			77.00				
Nicor Gas		3891395 4/1/21	KAS	Gas supply South Campus 3/1 - 4/1/21	04/01/2021	082287	843.20
				<i>Gas supply South Campus 3/1 - 4/1/21</i>			843.20
				<i>20 E 2540 4650 00 302 000000</i>			843.20

Invoice Listing

COUNTY OF GRUNDY SCHOOL DIST 111

Full Name	PO Number	Invoice Number	Batch	Description	Invoice Date	Check Number	Net Amount
Nicor Gas		5139697 4/1/21	KAS	Gas supply Central Campus 3/1 - 4/1/21	04/01/2021	082287	1,467.78
				<i>Gas supply Central Campus 3/1 - 4/1/21</i>			<i>1,467.78</i>
				<i>20 E 2540 4650 00 300 000000</i>			<i>1,467.78</i>
Nicor Gas		2785696 4/6/21	KAS	Gas supply Central Cafeteria 3/4/21 - 4/5/21	04/06/2021	082403	314.51
				<i>Gas supply Central Cafeteria 3/4/21 -</i>			<i>314.51</i>
				<i>20 E 2540 4650 00 300 000000</i>			<i>314.51</i>
Nicor Gas		3774126 4/6/21	KAS	Gas supply Central Campus 3/4/21 - 4/5/21	04/06/2021	082403	493.76
				<i>Gas supply Central Campus 3/4/21 -</i>			<i>493.76</i>
				<i>20 E 2540 4650 00 300 000000</i>			<i>493.76</i>
Nicor Gas		4874919 4/6/21	KAS	Gas supply Central Project Indian 3/4/21 - 4/5/21	04/06/2021	082403	51.72
				<i>Gas supply Central Project Indian 3/4/21</i>			<i>51.72</i>
				<i>20 E 2540 3400 00 301 000000</i>			<i>51.72</i>
	Nicor Gas		3,170.97				
Nykiel, Keith	1032100156	14249 3/26/21	KAS	*New Address* 875 Bluestem Dr. Bolingbrook, IL 60440 FB-VAR-3/26	03/26/2021	082288	77.00
				<i>FB-VAR-3/26</i>			<i>77.00</i>
				<i>10 E 1500 3190 30 300 000003</i>			<i>77.00</i>
	Nykiel, Keith		77.00				

Invoice Listing

COUNTY OF GRUNDY SCHOOL DIST 111

Full Name	PO Number	Invoice Number	Batch	Description	Invoice Date	Check Number	Net Amount
Oak Forest High School		1/28/21 Cheerleading	KAS	Cheerleading Oak Forest Invite Virtual - 2 teams	01/28/2021	082289	450.00
				<i>Cheerleading Oak Forest Invite Virtual -</i>			<i>450.00</i>
				<i>10 E 1500 3900 30 300 000000</i>			<i>450.00</i>
Oak Forest High School			450.00				
O'Leary, Martin	1032100211	29120 4/17/21	KAS	Official-FR FB-4/17/21	04/17/2021	082404	59.00
				<i>Official-FR FB-4/17/21</i>			<i>59.00</i>
				<i>10 E 1500 3190 30 300 000003</i>			<i>59.00</i>
O'Leary, Martin			59.00				
Osborne, Steve	1032100170	17278 4/1/21	KAS	BSOC-V-4/1	04/01/2021	082290	165 65.00
				<i>BSOC-V-4/1</i>			<i>65.00</i>
				<i>10 E 1500 3190 30 300 000001</i>			<i>65.00</i>
Osborne, Steve			65.00				
Oswego High School		2/27/21 Cheerleading	KAS	Cheerleading C V vs SPC Cheer Meet hosted by Oswego Spc Meet Varsity	02/27/2021	082291	55.00
				<i>Cheerleading C V vs SPC Cheer Meet</i>			<i>55.00</i>
				<i>10 E 1500 3900 30 300 000000</i>			<i>55.00</i>

Invoice Listing

COUNTY OF GRUNDY SCHOOL DIST 111

Full Name	PO Number	Invoice Number	Batch	Description	Invoice Date	Check Number	Net Amount
Oswego High School		2/27/21 Cheerleading Jr.	KAS	Cheerleading C V vs SPC Cheer Meet hosted by Oswego Spc Meet Jr. Varsity	02/27/2021	082291	55.00
				<i>Cheerleading C V vs SPC Cheer Meet</i>			<i>55.00</i>
				<i>10 E 1500 3900 30 300 000000</i>			<i>55.00</i>
Oswego High School			110.00				
Otis Elevator		100400340783	KAS	Maintenance Service from 5/1/21 to 4/30/22	04/11/2021	082405	3,092.88
				<i>Maintenance Service from 5/1/21 to</i>			<i>3,092.88</i>
				<i>20 E 2540 3900 00 302 000000</i>			<i>3,092.88</i>
Otis Elevator			3,092.88				
Paisley, Sam	1032100116	68504 3/9/21	KAS	Boys Soccer-Var-3-9-21	03/09/2021	082292	166 65.00
				<i>Boys Soccer-Var-3-9-21</i>			<i>65.00</i>
				<i>10 E 1500 3190 30 300 000001</i>			<i>65.00</i>
Paisley, Sam			65.00				
Parts Town, LLC		26546337	KAS	Pump, Motor	03/17/2021	082293	1,520.97
				<i>Pump, Motor</i>			<i>1,520.97</i>
				<i>20 E 2540 3230 00 300 000000</i>			<i>1,520.97</i>
Parts Town, LLC			1,520.97				

Invoice Listing

COUNTY OF GRUNDY SCHOOL DIST 111

Full Name	PO Number	Invoice Number	Batch	Description	Invoice Date	Check Number	Net Amount
Perspectives Ltd		98246	KAS	Employee Assistance Services - Monthly	04/01/2021	9100000345	540.00
				<i>Employee Assistance Services - Monthly</i>			540.00
				<i>10 E 2310 3000 00 300 000000</i>			540.00
Perspectives Ltd			540.00				
Peterson, Brian	1032100182	86005 4/2/21	KAS	Official-FB-V-4/2/21	04/02/2021	082406	77.00
				<i>Official-FB-V-4/2/21</i>			77.00
				<i>10 E 1500 3190 30 300 000003</i>			77.00
Peterson, Brian			77.00				
Pioneer Athletics		INV785824	KAS	Tournament Light Green 5 GL.	04/19/2021	082407	159.23
				<i>Tournament Light Green 5 GL.</i>			159.23
				<i>20 E 2540 4100 00 300 000001</i>			159.23
Pioneer Athletics			159.23				
Pizzo Native Plant	1132100004	SI-16088	KAS	Plants for Pollinator Garden	04/20/2021	082408	1,144.90
				<i>Plant order</i>			1,144.90
				<i>10 E 1130 4100 13 300 000000</i>			1,144.90
Pizzo Native Plant Nursery			1,144.90				

Invoice Listing

COUNTY OF GRUNDY SCHOOL DIST 111

Full Name	PO Number	Invoice Number	Batch	Description	Invoice Date	Check Number	Net Amount
PJMP LLC dba Rendels		P-119020	KAS	Tow Bus 48 3/4/21	03/04/2021	082294	187.50
				<i>Tow Bus 48 3/4/21</i>			<i>187.50</i>
				<i>40 E 2554 3230 00 300 000000</i>			<i>187.50</i>
PJMP LLC dba Rendels			187.50				
Platform Athletics	1122100022	2155	KAS	Platform is a yearly software subscription for our Weight Room classes. Please use the address below for billing. 39 John H Finley III Way Framingham, MA 01701 Phone 18558625502 Email billing@plt4m.com <i>PLT4M 1 Year Subscription</i>	03/16/2021	082295	1,500.00
				<i>10 E 1130 4100 50 300 000000</i>			<i>1,500.00</i>
Platform Athletics			1,500.00				
Plattos, Nicholas	1032100150	84019 3/26/21	KAS	FB-SO-3-26	03/26/2021	082296	59.00
				<i>FB-SO-3-26</i>			<i>59.00</i>
				<i>10 E 1500 3190 30 300 000003</i>			<i>59.00</i>
Plattos, Nicholas			59.00				
Plumbmaster		520-02619260	KAS	Zum E-Z Flush Sensor Kit, Metal Cover	03/04/2021	9100000346	1,109.08
				<i>Zum E-Z Flush Sensor Kit, Metal Cover</i>			<i>1,109.08</i>
				<i>20 E 2540 4100 00 302 000000</i>			<i>1,109.08</i>

Invoice Listing

COUNTY OF GRUNDY SCHOOL DIST 111

Full Name	PO Number	Invoice Number	Batch	Description	Invoice Date	Check Number	Net Amount
Plumbmaster		520-02619883	KAS	Sloan A-37-A Drop-in Kit, 1.5 GPF Urinal	03/04/2021	9100000346	151.08
				<i>Sloan A-37-A Drop-in Kit, 1.5 GPF Urinal</i>			151.08
				<i>20 E 2540 4100 00 302 000000</i>			151.08
Plumbmaster		520-02651594	KAS	Delta 701 Basin Fct.	04/08/2021	9100000369	542.52
				<i>Delta 701 Basin Fct.</i>			542.52
				<i>20 E 2540 4100 00 302 000000</i>			542.52
	Plumbmaster		1,802.68				
Powell, Willie	1032100113	63903 3/8/21	KAS	Girls Basketball VAR-3-8-21	03/08/2021	082297	67.00
				<i>Girls Basketball VAR-3-8-21</i>			67.00
				<i>10 E 1500 3190 30 300 000005</i>			67.00
	Powell, Willie		67.00				
Precision Control		SV34476	KAS	Mechanic's Labor and Travel to repair Flower Walk in Cooler	03/09/2021	082298	291.00
				<i>Mechanic's Labor and Travel to repair</i>			291.00
				<i>20 E 2540 3230 00 300 000000</i>			291.00

Invoice Listing

COUNTY OF GRUNDY SCHOOL DIST 111

Full Name	PO Number	Invoice Number	Batch	Description	Invoice Date	Check Number	Net Amount
Precision Control		SV34477	KAS	Mechanic's Labor and Travel to repair Reach in Kitchen Cooler	03/09/2021	082298	493.00
				<i>Mechanic's Labor and Travel to repair</i>			<i>493.00</i>
				<i>20 E 2540 3230 00 300 000000</i>			<i>493.00</i>
Precision Control Systems			784.00				
Prosek, Carrie M		2008163 557.00	KAS	HLTH5443 Technology, Leadership & Health Informatics - American College of Education	01/04/2021	9100000347	555.00
				<i>HLTH5443 Technology, Leadership &</i>			<i>555.00</i>
				<i>10 E 1130 2300 00 300 000000</i>			<i>555.00</i>
Prosek, Carrie M			555.00				
Prospect High School	1032100232	4/26/21 Boys Track	KAS	April 30, 2021 - Boys Track Invitational	04/26/2021	082409	170 300.00
				<i>April 30, 2021 - Boys Track Invitational</i>			<i>300.00</i>
				<i>10 E 1500 3900 30 300 000000</i>			<i>300.00</i>
Prospect High School			300.00				
Proven Business		787501	KAS	HP Copy Machines Contract 1/3/21 to 4/2/21 - Service calls, parts, labor, drums, rollers, blades, developer, toner bags, toner	04/14/2021	082410	50.39
				<i>HP Copy Machines Contract 1/3/21 to</i>			<i>50.39</i>
				<i>10 E 2632 3000 00 300 000000</i>			<i>50.39</i>
Proven Business Systems			50.39				

Invoice Listing

COUNTY OF GRUNDY SCHOOL DIST 111

Full Name	PO Number	Invoice Number	Batch	Description	Invoice Date	Check Number	Net Amount
Quadient Finance		3/14/21 11290896	KAS	Postage 2/22/21	03/14/2021	082299	883.69
				<i>Postage 2/22/21</i>			<i>1,000.00</i>
				<i>Postage - Credit</i>			<i>-116.31</i>
				<i>10 E 2410 3400 00 300 000000</i>			<i>1,000.00</i>
				<i>10 E 2410 3400 00 300 000000</i>			<i>-116.31</i>
Quadient Finance		4/12/21 11290896	KAS	Postage 3/18/21	04/12/2021	082411	5.00
				<i>Postage 3/18/21</i>			<i>5.00</i>
				<i>10 E 2410 3400 00 300 000000</i>			<i>5.00</i>
Quadient Finance		4/8/21 11290886	KAS	Postage 3/18/21, Supplies	04/08/2021	082411	1,042.72
				<i>Postage 3/18/21</i>			<i>1,000.00</i>
				<i>Supplies</i>			<i>42.72</i>
				<i>10 E 2410 3400 00 300 000000</i>			<i>1,000.00</i>
				<i>10 E 2410 3400 00 300 000000</i>			<i>42.72</i>
Quadient Finance			1,931.41				
Quadient Leasing USA,		N8769588	KAS	Lease Postage Machine - Central Campus 4-11-21 to 7-10-21	03/10/2021	082300	825.00
				<i>Lease Postage Machine - Central</i>			<i>825.00</i>
				<i>10 E 2410 3400 00 300 000000</i>			<i>825.00</i>

Invoice Listing

COUNTY OF GRUNDY SCHOOL DIST 111

Full Name	PO Number	Invoice Number	Batch	Description	Invoice Date	Check Number	Net Amount
Quadient Leasing USA,		N8769617	KAS	Lease Postage Machine - South Campus 4-11-21 to 7-10-21	03/11/2021	082300	825.00
				<i>Lease Postage Machine - South Campus</i>			825.00
				<i>10 E 2410 3400 00 300 000000</i>			825.00
Quadient Leasing USA, Inc.,			1,650.00				
Quantum Labs		INV-512448	KAS	Trueform Aloeform Nitrile Exam Glove	04/06/2021	9100000370	170.06
				<i>Trueform Aloeform Nitrile Exam Glove</i>			170.06
				<i>20 E 2540 4100 00 300 000000</i>			170.06
Quantum Labs			170.06				
Quest Food		IN109641	KAS	Catering - C. Ward Board Mtg. 3/17/21, J. Brockett Football Dinner 3/26/21	03/31/2021	9100000348	516.83
				<i>C. Ward Board Mtg. 3/17/21</i>			39.83
				<i>J. Brockett Football Dinner 3/26/21</i>			477.00
				<i>10 E 2560 3150 00 300 000000</i>			39.83
				<i>10 E 2560 3150 00 300 000000</i>			477.00

Invoice Listing

COUNTY OF GRUNDY SCHOOL DIST 111

Full Name	PO Number	Invoice Number	Batch	Description	Invoice Date	Check Number	Net Amount
Quest Food		IN109671	KAS	SFSP Lunch Meals, Management Fee March 2021	03/31/2021	9100000371	73,314.68
				<i>SFSP Lunch Meals, March 2021</i>			69,514.68
				<i>Management Fee, March 2021</i>			3,800.00
				<i>10 E 2560 3000 00 300 000000</i>			69,514.68
				<i>10 E 2560 3000 00 300 000000</i>			3,800.00
	Quest Food		73,831.51				
Quill Corporation		15183961	KAS	3x5 Index Cards, Self-stick Notes 3x3	03/09/2021	082301	39.93
				<i>3x5 Index Cards</i>			9.95
				<i>Self-stick Notes 3x3</i>			29.98
				<i>10 E 2525 4100 00 300 000000</i>			9.95
				<i>10 E 2525 4100 00 300 000000</i>			29.98
Quill Corporation		15612734	KAS	Flags & tabs	03/26/2021	082412	11.33
				<i>Flags & tabs</i>			11.33
				<i>40 E 2552 4100 00 300 000000</i>			11.33
Quill Corporation		15615487	KAS	Folders, dry erase markers, inkjoy gel, clips, Expo 16 color set	03/26/2021	082412	95.13
				<i>Folders, dry erase markers, inkjoy gel,</i>			95.13
				<i>40 E 2552 4100 00 300 000000</i>			95.13

Invoice Listing

COUNTY OF GRUNDY SCHOOL DIST 111

Full Name	PO Number	Invoice Number	Batch	Description	Invoice Date	Check Number	Net Amount
Quill Corporation		15627479	KAS	Labels	03/29/2021	082412	198.89
				<i>Labels</i>			198.89
				<i>40 E 2552 4100 00 300 000000</i>			198.89
Quill Corporation			345.28				
R & R Septic & Sewer		21-1935	KAS	Hydrojetting to open clog in grease trap line	04/23/2021	082413	600.00
				<i>Hydrojetting to open clog in grease trap</i>			600.00
				<i>20 E 2540 3230 00 300 000000</i>			600.00
R & R Septic & Sewer			600.00				
Radi-Link, Inc.		108077	KAS	Gia Tronics Remote Deskset, Bench labor, Labor	03/24/2021	082302	1,165.00
				<i>Gia Tronics Remote Deskset</i>			995.00
				<i>Bench labor</i>			85.00
				<i>Labor</i>			85.00
				<i>40 E 2554 3230 00 300 000000</i>			995.00
				<i>40 E 2554 3230 00 300 000000</i>			85.00
				<i>40 E 2554 3230 00 300 000000</i>			85.00
Radi-Link, Inc.			1,165.00				

Invoice Listing

COUNTY OF GRUNDY SCHOOL DIST 111

Full Name	PO Number	Invoice Number	Batch	Description	Invoice Date	Check Number	Net Amount
Rainbow Printing		00157915	KAS	2021-2022 Parking Passes	04/21/2021	082414	1,287.00
				<i>2021-2022 Parking Passes</i>			<i>1,287.00</i>
				<i>10 E 2490 4100 00 300 000000</i>			<i>1,287.00</i>
Rainbow Printing			1,287.00				
Reynolds, Charles	1032100117	57646 3/9/21	KAS	Boys Soccer-Var-3-9-21	03/09/2021	082303	65.00
				<i>Boys Soccer-Var-3-9-21</i>			<i>65.00</i>
				<i>10 E 1500 3190 30 300 000001</i>			<i>65.00</i>
Reynolds, Charles			65.00				
Rival5 Technologies		17678	KAS	Phone Service	04/01/2021	9100000349	175 729.07
				<i>Phone Service</i>			<i>729.07</i>
				<i>20 E 2540 3400 00 300 000001</i>			<i>729.07</i>
Rival5 Technologies		17733	KAS	Phone Service	04/01/2021	9100000349	4,380.29
				<i>Phone Service</i>			<i>4,380.29</i>
				<i>20 E 2540 3400 00 300 000001</i>			<i>4,380.29</i>

Invoice Listing

COUNTY OF GRUNDY SCHOOL DIST 111

Full Name	PO Number	Invoice Number	Batch	Description	Invoice Date	Check Number	Net Amount
Rival5 Technologies		17773	KAS	Algo 8301 Paging Adapter	04/01/2021	9100000349	442.48
				<i>Algo 8301 Paging Adapter</i>			442.48
				<i>20 E 2540 3400 00 300 000001</i>			442.48
Rival5 Technologies			5,551.84				
Rodriguez, Ruben	1032100252	34604 4/26/21	KAS	Official-BVB-V/JV-4/26/21	04/26/2021	082415	89.00
				<i>Official-BVB-V/JV-4/26/21</i>			89.00
				<i>10 E 1500 3190 30 300 000009</i>			89.00
Rodriguez, Ruben			89.00				
Rojas, Michael	1032100090	70294 2/27/21	KAS	Boys Basketball Official - SO - 2/27/21	02/27/2021	082304	176 53.00
				<i>Boys Basketball Official - SO - 2/27/21</i>			53.00
				<i>10 E 1500 3190 30 300 000004</i>			53.00
Rojas, Michael			53.00				
Ryan, Jonathan J	1032100140	26014 3/20/21	KAS	Football-FR-3-20-21	03/20/2021	082305	92.00
				<i>Football-FR-3-20-21</i>			92.00
				<i>10 E 1500 3190 30 300 000003</i>			92.00

Invoice Listing

COUNTY OF GRUNDY SCHOOL DIST 111

Full Name	PO Number	Invoice Number	Batch	Description	Invoice Date	Check Number	Net Amount
Ryan, Jonathan J	1032100167	26014 4/2/21	KAS	FB-S-4/2	04/02/2021	082305	59.00
				<i>FB-S-4/2</i>			59.00
				<i>10 E 1500 3190 30 300 000003</i>			59.00
Ryan, Jonathan J	1032100248	26014 4/23/21	KAS	Official-FB-SO - 4/23/21	04/23/2021	082416	59.00
				<i>Official-FB-SO - 4/23/21</i>			59.00
				<i>10 E 1500 3190 30 300 000003</i>			59.00
Ryan, Jonathan J			210.00				
Ryan, Tim	1032100114	13840 3/8/21	KAS	Girls Basketball VAR-3-8-21	03/08/2021	082306	67.00 177
				<i>Girls Basketball VAR-3-8-21</i>			67.00
				<i>10 E 1500 3190 30 300 000005</i>			67.00
Ryan, Tim			67.00				
Sachnoff, Donald	1032100126	13982 3/6/21	KAS	Girls Basketball-VAR-3-6-21	03/06/2021	082307	67.00
				<i>Girls Basketball-VAR-3-6-21</i>			67.00
				<i>10 E 1500 3190 30 300 000005</i>			67.00

Invoice Listing

COUNTY OF GRUNDY SCHOOL DIST 111

Full Name	PO Number	Invoice Number	Batch	Description	Invoice Date	Check Number	Net Amount
Sachnoff, Donald	1032100229	13982 4/21/21	KAS	Official-GVB-V-4/21/21	04/21/2021	082417	56.00
				<i>Official-GVB-V-4/21/21</i>			56.00
				<i>10 E 1500 3190 30 300 000000</i>			56.00
Sachnoff, Donald			123.00				
Satorius, Adam P	1032100207	55723 4/13/21	KAS	Official-Baseball-4-13-21	04/13/2021	9100000372	65.00
				<i>Official-Baseball-4-13-21</i>			65.00
				<i>10 E 1500 3190 30 300 000007</i>			65.00
Satorius, Adam P			65.00				
Schaefer, Tom	1032100186	30836 4/1/21	KAS	Official-BSOC-V-4/1/21	04/01/2021	082418	178 65.00
				<i>Official-BSOC-V-4/1/21</i>			65.00
				<i>10 E 1500 3190 30 300 000001</i>			65.00
Schaefer, Tom	1032100218	30836 4/15/21	KAS	Officials GSOC-V-4-15-21	04/15/2021	082418	65.00
				<i>Officials GSOC-V-4-15-21</i>			65.00
				<i>10 E 1500 3190 30 300 000012</i>			65.00
Schaefer, Tom			130.00				

Invoice Listing

COUNTY OF GRUNDY SCHOOL DIST 111

Full Name	PO Number	Invoice Number	Batch	Description	Invoice Date	Check Number	Net Amount
Schneider Electric		835007	KAS	Overvoltage Controller ahv3	02/25/2021	082308	3,204.32
				<i>Overvoltage Controller ahv3</i>			3,204.32
				<i>20 E 2540 3900 00 302 000000</i>			3,204.32
Schneider Electric			3,204.32				
Scholastic Library	1012100060	26972839	KAS	Scholastic Go Database Renewal	02/01/2021	082419	1,323.00
				<i>Scholastic Go Database renewal</i>			1,323.00
				<i>10 E 2222 4400 00 300 000000</i>			1,323.00
Scholastic Library Publishing			1,323.00				
Screencastify		SC-288734	KAS	Record and Edit Unlimited District Plan 8/27/20 to 8/27/21	08/27/2020	082309	1,500.00
				<i>Record Unlimited District Plan</i>			750.00
				<i>Edit Unlimited District Plan</i>			750.00
				<i>10 E 2225 4700 00 300 000000</i>			750.00
				<i>10 E 2225 4700 00 300 000000</i>			750.00
Screencastify			1,500.00				
Sebenik, William	1032100168	53612 4/2/21	KAS	FB-S-4/2	04/02/2021	082420	59.00
				<i>FB-S-4/2</i>			59.00
				<i>10 E 1500 3190 30 300 000003</i>			59.00

Invoice Listing

COUNTY OF GRUNDY SCHOOL DIST 111

Full Name	PO Number	Invoice Number	Batch	Description	Invoice Date	Check Number	Net Amount
Sebenik, William	1032100246	53612 4/23/21	KAS	Official-FB-SO - 4/23/21	04/23/2021	082420	59.00
				<i>Official-FB-SO - 4/23/21</i>			59.00
				<i>10 E 1500 3190 30 300 000003</i>			59.00
Sebenik, William			118.00				
Semega, Lawrence	1032100255	84992 4/26/21	KAS	Official-SB-VAR-4/26/21	04/26/2021	082421	65.00
				<i>Official-SB-VAR-4/26/21</i>			65.00
				<i>10 E 1500 3190 30 300 000002</i>			65.00
Semega, Lawrence			65.00				
Senor, Kevin	1032100109	22895 3/5/21	KAS	Boys Basketball VAR-3-5-21	03/05/2021	082310	180 67.00
				<i>Boys Basketball VAR-3-5-21</i>			67.00
				<i>10 E 1500 3190 30 300 000004</i>			67.00
Senor, Kevin			67.00				
Shaw Media		1874003	KAS	Parking Lot Drainage Bid	04/16/2021	082422	71.18
				<i>Parking Lot Drainage Bid</i>			71.18
				<i>10 E 2310 4100 00 300 000000</i>			71.18

Invoice Listing

COUNTY OF GRUNDY SCHOOL DIST 111

Full Name	PO Number	Invoice Number	Batch	Description	Invoice Date	Check Number	Net Amount
Shaw Media		1875458ROP	KAS	Annual Statement of Affairs 2020	04/26/2021	082422	1,130.40
				<i>Annual Statement of Affairs 2020</i>			<i>1,130.40</i>
				<i>10 E 2310 4100 00 300 000000</i>			<i>1,130.40</i>
Shaw Media			1,201.58				
Sherrick, Elizabeth M		2011118 558.00	KAS	HLTH5443 Technology, Leadership & Health Informatics - American College of Education	02/02/2021	9100000350	555.00
				<i>HLTH5443 Technology, Leadership &</i>			<i>555.00</i>
				<i>10 E 1130 2300 00 300 000000</i>			<i>555.00</i>
Sherrick, Elizabeth M			555.00				
Shields, Trevor C	1012100089	35778227	KAS	The Washington Post Subscription for teacher use for course materials Trevor Shields	03/31/2021	9100000351	181 29.00
				<i>The Washington Post Subscription for</i>			<i>29.00</i>
				<i>10 E 1130 4100 15 300 000000</i>			<i>29.00</i>
Shields, Trevor C			29.00				
Simpkins, Eugene	1032100159	58999 3/29/21	KAS	Boys Soccer-VAR-3/29/21	03/29/2021	082311	65.00
				<i>Boys Soccer-VAR-3/29/21</i>			<i>65.00</i>
				<i>10 E 1500 3190 30 300 000001</i>			<i>65.00</i>
Simpkins, Eugene			65.00				

Invoice Listing

COUNTY OF GRUNDY SCHOOL DIST 111

Full Name	PO Number	Invoice Number	Batch	Description	Invoice Date	Check Number	Net Amount
Skrabis, Mike	1032100128	25540 3/8/21	KAS	Boys Basketball - Var - 3-8-21	03/08/2021	082312	67.00
				<i>Boys Basketball - Var - 3-8-21</i>			67.00
				<i>10 E 1500 3190 30 300 000004</i>			67.00
Skrabis, Mike			67.00				
Slusher, Matthew W		2014364 554.00	KAS	ED5303 Principles of Human Learning, HLTH5443 Technology, Leadership & Health Informatics - American College of Education	04/12/2021	9100000373	1,110.00
				<i>ED5303 Principles of Human Learning</i>			555.00
				<i>HLTH5443 Technology, Leadership &</i>			555.00
				<i>10 E 1130 2300 00 300 000000</i>			555.00
				<i>10 E 1130 2300 00 300 000000</i>			555.00
Slusher, Matthew W			1,110.00				
Smith, Glenda R		4/14/21 Musical	KAS	Musical Props and Supplies from Amazon and Oriental Trading	04/14/2021	9100000374	284.25
				<i>Musical Props and Supplies from</i>			284.25
				<i>10 E 1500 4100 70 300 000004</i>			284.25
Smith, Glenda R			284.25				
Smith, Matthew B		2014306 555.00	KAS	HLTH 5443 Technology, Leadership and Health Informatics - American College of Education	01/07/2021	9100000352	555.00
				<i>HLTH 5443 Technology, Leadership and</i>			555.00
				<i>10 E 1130 2300 00 300 000000</i>			555.00
Smith, Matthew B			555.00				

Invoice Listing

COUNTY OF GRUNDY SCHOOL DIST 111

Full Name	PO Number	Invoice Number	Batch	Description	Invoice Date	Check Number	Net Amount
South Elgin High School		2/13/21 Dance	KAS	Competitive Dance G V and JV vs Invitational South Elgin	02/13/2021	082313	250.00
				<i>Dance Varsity</i>			125.00
				<i>Dance Jr. Varsity</i>			125.00
				<i>10 E 1500 3900 30 300 000000</i>			125.00
				<i>10 E 1500 3900 30 300 000000</i>			125.00
South Elgin High School			250.00				
Spiezio, Joseph	1032100237	25935 4/24/21	KAS	Official - Baseball-SO - 4/24/21 (D/H)	04/24/2021	082423	100.00
				<i>Official - Baseball-SO - 4/24/21 (D/H)</i>			100.00
				<i>10 E 1500 3190 30 300 000007</i>			100.00
Spiezio, Joseph			100.00				
Spinelli, Arthur	1032100254	72167 4/26/21	KAS	Official-SB-VAR-4/26/21	04/26/2021	082424	65.00
				<i>Official-SB-VAR-4/26/21</i>			65.00
				<i>10 E 1500 3190 30 300 000002</i>			65.00
Spinelli, Arthur	1032100261	72167 4/27/21	KAS	Official-SB-JV-4/27/21	04/27/2021	082424	56.00
				<i>Official-SB-JV-4/27/21</i>			56.00
				<i>10 E 1500 3190 30 300 000002</i>			56.00
Spinelli, Arthur			121.00				

Invoice Listing

COUNTY OF GRUNDY SCHOOL DIST 111

Full Name	PO Number	Invoice Number	Batch	Description	Invoice Date	Check Number	Net Amount
Sports Huddle		56296	KAS	Lacrosse Balls, Decals, Pinnies	07/17/2020	082314	1,680.00
				<i>Lacrosse Balls</i>			<i>190.00</i>
				<i>Decals</i>			<i>60.00</i>
				<i>Pinnies</i>			<i>1,430.00</i>
				<i>10 E 1500 4100 30 300 000026</i>			<i>190.00</i>
				<i>10 E 1500 4100 30 300 000026</i>			<i>60.00</i>
				<i>10 E 1500 4100 30 300 000026</i>			<i>1,430.00</i>
Sports Huddle		57057	KAS	Signs for Football Stadium with Stakes - Home, Visitors, Students 15 of each	03/26/2021	082425	1,035.00 184
				<i>Signs for Football Stadium with Stakes -</i>			<i>1,035.00</i>
				<i>20 E 2540 4100 00 300 000001</i>			<i>1,035.00</i>
Sports Huddle			2,715.00				
Spreitzer, Keith	1032100238	74829 4/24/21	KAS	Official - Baseball-FR - 4/24/21 (D/H)	04/24/2021	082426	100.00
				<i>Official - Baseball-FR - 4/24/21 (D/H)</i>			<i>100.00</i>
				<i>10 E 1500 3190 30 300 000007</i>			<i>100.00</i>
Spreitzer, Keith	1032100263	74829 4/27/21	KAS	Official-BB-FR-4/27/21 *NEW ADDRESS* 527 Lloyd Dr. Dwight, IL 60420	04/27/2021	082426	62.00
				<i>Official-BB-FR-4/27/21</i>			<i>62.00</i>
				<i>10 E 1500 3190 30 300 000007</i>			<i>62.00</i>
Spreitzer, Keith			162.00				

Invoice Listing

COUNTY OF GRUNDY SCHOOL DIST 111

Full Name	PO Number	Invoice Number	Batch	Description	Invoice Date	Check Number	Net Amount
Stewart, Paul	1032100148	72609 3/26/21	KAS	FB-SO-3-26	03/26/2021	082315	59.00
				<i>FB-SO-3-26</i>			59.00
				<i>10 E 1500 3190 30 300 000003</i>			59.00
Stewart, Paul	1032100233	42609 4/24/21	KAS	Official-Baseball-FR - 4/24/21 (D/H)	04/24/2021	082427	100.00
				<i>Official-Baseball-FR - 4/24/21 (D/H)</i>			100.00
				<i>10 E 1500 3190 30 300 000007</i>			100.00
Stewart, Paul			159.00				
Stiff, Deveon	1032100153	49294 3/26/21	KAS	FB-VAR-3-26	03/26/2021	082316	77.00
				<i>FB-VAR-3-26</i>			77.00
				<i>10 E 1500 3190 30 300 000003</i>			77.00
Stiff, Deveon			77.00				
Strawberry Plant		3/23/21 Flowers	KAS	Sympathy Flowers - Laverne Tischer	04/23/2021	082317	75.00
				<i>Sympathy Flowers - Laverne Tischer</i>			75.00
				<i>10 E 2310 4100 00 300 000000</i>			75.00
Strawberry Plant Boutique			75.00				

Invoice Listing

COUNTY OF GRUNDY SCHOOL DIST 111

Full Name	PO Number	Invoice Number	Batch	Description	Invoice Date	Check Number	Net Amount
Struck, Peter	1032100208	35834 4/13/21	KAS	Official-TR&FLD-4-13-21	04/13/2021	082428	112.00
				<i>Official-TR&FLD-4-13-21</i>			112.00
				<i>10 E 1500 3190 30 300 000010</i>			112.00
Struck, Peter	1032100227	35834 4/19/21	KAS	Official-BTR-4/19/21	04/19/2021	082428	112.00
				<i>Official-BTR-4/19/21</i>			112.00
				<i>10 E 1500 3190 30 300 000011</i>			112.00
Struck, Peter			224.00				
Sudd, Robert	1032100106	77098 3/5/21	KAS	Boys Basketball So-3-5-21	03/05/2021	082318	53.00
				<i>Boys Basketball So-3-5-21</i>			53.00
				<i>10 E 1500 3190 30 300 000004</i>			53.00
Sudd, Robert			53.00				
Thomas, James	1032100135	14765 3/18/21	KAS	Girls Volleyball-FR A&B-3/18/21	03/18/2021	082319	88.00
				<i>Girls Volleyball-FR A&B-3/18/21</i>			88.00
				<i>10 E 1500 3190 30 300 000000</i>			88.00
Thomas, James			88.00				

Invoice Listing

COUNTY OF GRUNDY SCHOOL DIST 111

Full Name	PO Number	Invoice Number	Batch	Description	Invoice Date	Check Number	Net Amount
Thompson Electronics		97645	KAS	Work on fire pumps - reset water flow switch that was stuck	04/22/2021	082429	180.00
				<i>Work on fire pumps - reset water flow</i>			180.00
				<i>20 E 2540 3900 00 302 000000</i>			180.00
Thompson Electronics			180.00				
Thomson Reuters -		844112952	KAS	West Information Charges 3/1 to 3/31/21	04/01/2021	082320	387.45
				<i>West Information Charges 3/1 to 3/31/21</i>			387.45
				<i>10 E 2125 3000 00 302 000000</i>			387.45
Thomson Reuters - West			387.45				
Timberline Billing		21350	KAS	Monthly Billing Fee - Medicaid check for March 2021 \$756.95	03/31/2021	9100000353	187.52.99
				<i>Monthly Billing Fee - Medicaid check for</i>			52.99
				<i>10 E 1200 3000 00 300 000000</i>			52.99
Timberline Billing Service			52.99				

Invoice Listing

COUNTY OF GRUNDY SCHOOL DIST 111

Full Name	PO Number	Invoice Number	Batch	Description	Invoice Date	Check Number	Net Amount
Total Fitness	1122100015	2021035	KAS	Wellness Room Cardio Equipment	01/14/2021	082321	11,092.40
				<i>Sports Art T645 Treadmill</i>		4,450.00	
				<i>Body Solid R300 Rower</i>		1,870.00	
				<i>Body Solid Endurance Fan Bike</i>		3,557.40	
				<i>Rower & Treadmill Installation</i>		375.00	
				<i>Fan Bike Installation</i>		360.00	
				<i>Freight</i>		480.00	
				<i>10 E 3200 5000 00 300 000000</i>		4,450.00	188
				<i>10 E 3200 5000 00 300 000000</i>		1,870.00	
				<i>10 E 3200 5000 00 300 000000</i>		3,557.40	
				<i>10 E 3200 5000 00 300 000000</i>		375.00	
				<i>10 E 3200 5000 00 300 000000</i>		360.00	
				<i>10 E 3200 5000 00 300 000000</i>		480.00	
Total Fitness			11,092.40				
Transport Safety Lane		44904	KAS	Vehicle Safety Inspections	02/03/2021	082322	585.00
				<i>Vehicle Safety Inspections</i>		585.00	
				<i>40 E 2554 3390 00 300 000000</i>		585.00	

Invoice Listing

COUNTY OF GRUNDY SCHOOL DIST 111

Full Name	PO Number	Invoice Number	Batch	Description	Invoice Date	Check Number	Net Amount
Transport Safety Lane		44949	KAS	Vehicle Safety Inspections	03/01/2021	082430	351.00
				<i>Vehicle Safety Inspections</i>			351.00
				<i>40 E 2554 3390 00 300 000000</i>			351.00
Transport Safety Lane			936.00				
Tri-K Inc		115472	KAS	Tri-Kling, Foam Soap, Roll Towels, 9" Tissue, Microfiber Towels	03/09/2021	082323	936.36
				<i>Tri-Kling</i>			85.20
				<i>Foam Soap</i>			207.36
				<i>Roll Towels</i>			236.80
				<i>9" Tissue</i>			291.20
				<i>Microfiber towels</i>			115.80
				<i>20 E 2540 4100 00 300 000000</i>			85.20
				<i>20 E 2540 4100 00 300 000000</i>			207.36
				<i>20 E 2540 4100 00 300 000000</i>			236.80
				<i>20 E 2540 4100 00 300 000000</i>			291.20
				<i>20 E 2540 4100 00 300 000000</i>			115.80

Invoice Listing

COUNTY OF GRUNDY SCHOOL DIST 111

Full Name	PO Number	Invoice Number	Batch	Description	Invoice Date	Check Number	Net Amount
Tri-K Inc		115518	KAS	Virex, Kitchen towels, Roll Towels, 9" Tissue, Steriphone	03/16/2021	082323	1,574.98
				<i>Virex</i>		468.00	
				<i>Kitchen towels</i>		340.80	
				<i>Roll towels</i>		296.00	
				<i>9" Tissue</i>		291.20	
				<i>Steriphone</i>		178.98	
				<i>20 E 2540 4100 00 300 000000</i>		468.00	
				<i>20 E 2540 4100 00 300 000000</i>		340.80	190
				<i>20 E 2540 4100 00 300 000000</i>		296.00	
				<i>20 E 2540 4100 00 300 000000</i>		291.20	
				<i>20 E 2540 4100 00 300 000000</i>		178.98	
Tri-K Inc		115582	KAS	Kitchen Roll Towels	03/25/2021	082323	113.60
				<i>Kitchen Roll Towels</i>		113.60	
				<i>20 E 2540 4100 00 302 000000</i>		113.60	

Invoice Listing

COUNTY OF GRUNDY SCHOOL DIST 111

Full Name	PO Number	Invoice Number	Batch	Description	Invoice Date	Check Number	Net Amount
Tri-K Inc		115671	KAS	Roll Towels, Tissue, Kitchen Towels, Virex, Steriphene, Soap	04/06/2021	082431	1,391.78
				<i>Roll Towels</i>		296.00	
				<i>Tissue</i>		145.60	
				<i>Kitchen Towels</i>		113.60	
				<i>Virex</i>		312.00	
				<i>Steriphene</i>		178.98	
				<i>Soap</i>		345.60	
				<i>20 E 2540 4100 00 300 000000</i>		296.00	191
				<i>20 E 2540 4100 00 300 000000</i>		145.60	
				<i>20 E 2540 4100 00 300 000000</i>		113.60	
				<i>20 E 2540 4100 00 300 000000</i>		312.00	
				<i>20 E 2540 4100 00 300 000000</i>		178.98	
				<i>20 E 2540 4100 00 300 000000</i>		345.60	
Tri-K Inc		115715	KAS	Bottles, Triggers	04/12/2021	082431	66.72
				<i>Bottles</i>		21.36	
				<i>Triggers</i>		45.36	
				<i>20 E 2540 4100 00 302 000000</i>		21.36	
				<i>20 E 2540 4100 00 302 000000</i>		45.36	

Invoice Listing

COUNTY OF GRUNDY SCHOOL DIST 111

Full Name	PO Number	Invoice Number	Batch	Description	Invoice Date	Check Number	Net Amount
Tri-K Inc		115739	KAS	Tri-king, Liners, Tissue, Towels	04/14/2021	082431	1,126.80
				<i>Tri-king</i>		85.20	
				<i>Liners</i>		475.20	
				<i>Liners</i>		236.40	
				<i>Tissue</i>		182.00	
				<i>Towels</i>		148.00	
				<i>20 E 2540 4100 00 300 000000</i>		85.20	
				<i>20 E 2540 4100 00 300 000000</i>		475.20	192
				<i>20 E 2540 4100 00 300 000000</i>		236.40	
				<i>20 E 2540 4100 00 300 000000</i>		182.00	
				<i>20 E 2540 4100 00 300 000000</i>		148.00	

Invoice Listing

COUNTY OF GRUNDY SCHOOL DIST 111

Full Name	PO Number	Invoice Number	Batch	Description	Invoice Date	Check Number	Net Amount
Tri-K Inc		115774	KAS	Red Pads, Tennant Parts	04/19/2021	082431	398.40
				<i>Red Pads</i>			216.00
				<i>Tennant Parts 86859</i>			90.60
				<i>Tennant Parts 390943</i>			37.80
				<i>Tennant Parts 390942</i>			54.00
				<i>20 E 2540 4100 00 300 000000</i>			216.00
				<i>20 E 2540 4100 00 300 000000</i>			90.60
				<i>20 E 2540 4100 00 300 000000</i>			37.80
				<i>20 E 2540 4100 00 300 000000</i>			54.00
							193
	Tri-K Inc		5,608.64				
Ulmer, David	1032100149	83640 3/26/21	KAS	FB-SO-3-26	03/26/2021	082324	59.00
				<i>FB-SO-3-26</i>			59.00
				<i>10 E 1500 3190 30 300 000003</i>			59.00
	Ulmer, David		59.00				
Umb Bank		MIN9 4/2/21	KAS	Registered Interest and Matured Bonds payments	04/02/2021	9100000375	397,425.00
				<i>Registered Interest</i>			397,425.00
				<i>30 E 5140 6200 00 300 000005</i>			397,425.00
	Umb Bank		397,425.00				

Invoice Listing

COUNTY OF GRUNDY SCHOOL DIST 111

Full Name	PO Number	Invoice Number	Batch	Description	Invoice Date	Check Number	Net Amount
United Laboratories		INV312145	KAS	Devour Power F/Drain Maint.	03/10/2021	9100000354	1,074.12
				<i>Devour Power F/Drain Maint.</i>			<i>1,074.12</i>
				<i>20 E 2540 4100 00 300 000000</i>			<i>1,074.12</i>
United Laboratories			1,074.12				
University of Illinois,		S2890494	KAS	Christina M. Daurer UIN 650169460 Tuition, Fees	02/13/2021	082432	5,820.00
				<i>Christina M. Daurer UIN 650169460</i>			<i>5,649.00</i>
				<i>Christina M. Daurer UIN 650169460</i>			<i>126.00</i>
				<i>Christina M. Daurer UIN 650169460</i>			<i>45.00</i>
				<i>10 E 1130 2300 00 300 000000</i>			<i>5,649.00</i>
				<i>10 E 1130 2300 00 300 000000</i>			<i>126.00</i>
				<i>10 E 1130 2300 00 300 000000</i>			<i>45.00</i>
University of Illinois, Attn:			5,820.00				
UPS		Y75060131	KAS	Package pick-up	03/27/2021	082325	4.44
				<i>Package pick-up</i>			<i>4.44</i>
				<i>10 E 2410 3400 00 300 000000</i>			<i>4.44</i>
UPS			4.44				

Invoice Listing

COUNTY OF GRUNDY SCHOOL DIST 111

Full Name	PO Number	Invoice Number	Batch	Description	Invoice Date	Check Number	Net Amount
Us Bank		6071755	KAS	G.O. Refunding School Bonds, Series 2014	03/25/2021	082326	550.00
				<i>G.O. Refunding School Bonds, Series</i>			<i>550.00</i>
				<i>30 E 5900 3900 00 300 000000</i>			<i>550.00</i>
Us Bank		6071846	KAS	G.O. Refunding School Bonds, Series 2016B	03/25/2021	082326	500.00
				<i>G.O. Refunding School Bonds, Series</i>			<i>500.00</i>
				<i>30 E 5900 3900 00 300 000000</i>			<i>500.00</i>
Us Bank			1,050.00				
Us Bank Equipment		439417171	KAS	Canon Copiers 3/20 to 4/20/21	04/20/2021	082327	16,406.06
				<i>Canon Copiers 3/20 to 4/20/21</i>			<i>16,406.06</i>
				<i>10 E 2632 3000 00 300 000000</i>			<i>16,406.06</i>
Us Bank Equipment Finance			16,406.06				
Vandermoon, Scott	1032100181	47414 4/2/21	KAS	Official-FB-V-4/2/21	04/02/2021	082433	77.00
				<i>Official-FB-V-4/2/21</i>			<i>77.00</i>
				<i>10 E 1500 3190 30 300 000003</i>			<i>77.00</i>
Vandermoon, Scott			77.00				

Invoice Listing

COUNTY OF GRUNDY SCHOOL DIST 111

Full Name	PO Number	Invoice Number	Batch	Description	Invoice Date	Check Number	Net Amount
Verizon Wireless		9876718437	KAS	Cell Phone Services 3/2 - 4/1/21	04/01/2021	082328	693.76
				<i>Cell Phone Services 3/2 - 4/1/21</i>			693.76
				<i>20 E 2540 3400 00 300 000001</i>			693.76
Verizon Wireless			693.76				
Vestal, Danny	1032100139	68246 3/20/21	KAS	Football-FR-3-20-21	03/20/2021	082329	92.00
				<i>Football-FR-3-20-21</i>			92.00
				<i>10 E 1500 3190 30 300 000003</i>			92.00
Vestal, Danny			92.00				
Village Of Channahon		0000001407	KAS	Officer Hartmann Feb. 2021	02/28/2021	082330	4,668.07
				<i>Officer Hartmann Feb. 2021</i>			4,668.07
				<i>80 E 2365 3900 00 302 000000</i>			4,668.07
Village Of Channahon		0000001411	KAS	Officer Hartmann Mar. 2021	03/31/2021	082330	4,668.07
				<i>Officer Hartmann Mar. 2021</i>			4,668.07
				<i>80 E 2365 3900 00 302 000000</i>			4,668.07

Invoice Listing

COUNTY OF GRUNDY SCHOOL DIST 111

Full Name	PO Number	Invoice Number	Batch	Description	Invoice Date	Check Number	Net Amount
Village Of Channahon		0000001412	KAS	Officer Hartmann Games 2/23, 2/27, 3/5, 3/6, 3/8/21	03/31/2021	082330	973.16
				<i>Hartman Game 2/23/21</i>			249.53
				<i>Hartman Game 2/27/21</i>			249.53
				<i>Hartman Game 3/5/21</i>			199.62
				<i>Hartman Game 3/6/21</i>			199.62
				<i>Hartman Game 3/8/21</i>			74.86
				80 E 2365 3900 00 302 000000			249.53
				80 E 2365 3900 00 302 000000			249.53
				80 E 2365 3900 00 302 000000			199.62
				80 E 2365 3900 00 302 000000			199.62
				80 E 2365 3900 00 302 000000			74.86
Village Of Channahon		0000001416	KAS	Traffic Light Maintenance - Mar. 2021	03/31/2021	082330	100.00
				<i>Traffic Light Maintenance - Mar. 2021</i>			100.00
				20 E 2540 3900 00 302 000000			100.00
Village Of Channahon		EAMS-026655-0000-01	KAS	Utility Bill - Water and Sewer from 3/1 to 3/31/21	04/01/2021	082330	1,578.39
				<i>Utility Bill - Water and Sewer from 3/1 to</i>			1,578.39
				20 E 2540 3700 00 302 000000			1,578.39
Village Of Channahon			11,987.69				

Invoice Listing

COUNTY OF GRUNDY SCHOOL DIST 111

Full Name	PO Number	Invoice Number	Batch	Description	Invoice Date	Check Number	Net Amount
Village Of Minooka		10619	KAS	Resource Officer Larson - 137.50 hrs. 3/4 and 3/18/21 Payroll Periods	03/30/2021	9100000355	7,140.34
				<i>Resource Officer Larson - 137.50 hrs.</i>			<i>7,140.34</i>
				<i>80 E 2365 3900 00 300 000001</i>			<i>7,140.34</i>
Village Of Minooka		10620	KAS	Resource Officer Larson OT - 71.00 hrs. 3/4 and 3/18/21 Payroll Periods	03/30/2021	9100000355	5,530.96
				<i>Resource Officer Larson OT - 71.00 hrs.</i>			<i>5,530.96</i>
				<i>80 E 2365 3900 00 300 000001</i>			<i>5,530.96</i>
Village Of Minooka		1-08000400-01 3/1/21	KAS	Water and Sewer 12/18/20 to 2/19/21 - Bus Garage	03/01/2021	9100000355	63.02
				<i>Water and Sewer 10/20 to 12/18/20 -</i>			<i>63.02</i>
				<i>40 E 2550 3700 00 300 000000</i>			<i>63.02</i>
Village Of Minooka			12,734.32				
Villani, Kimberly E		2008220 517.00	KAS	EEND 725 Legendary Teacher Traits - Univ. of St. Francis	04/15/2021	9100000376	555.00
				<i>EEND 725 Legendary Teacher Traits -</i>			<i>555.00</i>
				<i>10 E 1130 2300 00 300 000000</i>			<i>555.00</i>
Villani, Kimberly E			555.00				
Villegas, Jose	1032100177	71367 4/6/21	KAS	Official-BSOC-V-4/6/21	04/06/2021	082434	65.00
				<i>Official-BSOC-V-4/6/21</i>			<i>65.00</i>
				<i>10 E 1500 3190 30 300 000001</i>			<i>65.00</i>

Invoice Listing

COUNTY OF GRUNDY SCHOOL DIST 111

Full Name	PO Number	Invoice Number	Batch	Description	Invoice Date	Check Number	Net Amount
Villegas, Jose	1032100256	71367 4/26/21	KAS	Official-GSOC-V-4/26/21	04/26/2021	082434	65.00
				<i>Official-GSOC-V-4/26/21</i>			65.00
				<i>10 E 1500 3190 30 300 000012</i>			65.00
Villegas, Jose			130.00				
Vinton, William	1032100145	49676 3/25/21	KAS	BSOC-V-3/25/21	03/25/2021	082331	65.00
				<i>BSOC-V-3/25/21</i>			65.00
				<i>10 E 1500 3190 30 300 000001</i>			65.00
Vinton, William	1032100217	49676 4/15/21	KAS	Officials GSOC-V-4-15-21	04/15/2021	082435	65.00
				<i>Officials GSOC-V-4-15-21</i>			65.00
				<i>10 E 1500 3190 30 300 000012</i>			65.00
Vinton, William	1032100258	60543 4/26/21	KAS	Official-GSOC-V-4/26/21	04/26/2021	082435	65.00
				<i>Official-GSOC-V-4/26/21</i>			65.00
				<i>10 E 1500 3190 30 300 000012</i>			65.00
Vinton, William			195.00				

Invoice Listing

COUNTY OF GRUNDY SCHOOL DIST 111

Full Name	PO Number	Invoice Number	Batch	Description	Invoice Date	Check Number	Net Amount
Vision Service Plan		811883893	KAS	Robert VanDolson - Family, Anne Blanco - Children April 2021	03/17/2021	082332	38.92
				<i>Robert VanDolson April 2021 Family</i>			19.46
				<i>Anne Blanco April 2021 Children</i>			19.46
				<i>20 E 2540 2220 00 300 000000</i>			19.46
				<i>10 E 1130 2220 05 300 000000</i>			19.46
Vision Service Plan			38.92				
Waecker, Steven	1032100202	34858 4/12/21	KAS	Official-BSOC-4/12/21	04/12/2021	082436	65.00
				<i>Official-BSOC-4/12/21</i>			65.00
				<i>10 E 1500 3190 30 300 000001</i>			65.00
Waecker, Steven			65.00				
Walker Thomas Group		0724	KAS	In-house Suspension Mutual Respect, Inclusion and Belonging for Students 4/15/21, Monthly Consulting Retainer 4/21	04/18/2021	082437	5,000.00
				<i>In-house Suspension Mutual Respect,</i>			4,500.00
				<i>Monthly Consulting Retainer 4/21</i>			500.00
				<i>10 E 2310 3000 00 300 000000</i>			4,500.00
				<i>10 E 2310 3000 00 300 000000</i>			500.00
Walker Thomas Group			5,000.00				

Invoice Listing

COUNTY OF GRUNDY SCHOOL DIST 111

Full Name	PO Number	Invoice Number	Batch	Description	Invoice Date	Check Number	Net Amount
Walker, Kellen J	1032100221	83934 4/15/21	KAS	Official-SO BB-4/15/21	04/15/2021	082438	56.00
				<i>Official-SO BB-4/15/21</i>			56.00
				<i>10 E 1500 3190 30 300 000007</i>			56.00
Walker, Kellen J	1032100262	83934 4/27/21	KAS	Official-BB-SO-4/27/21	04/27/2021	082438	62.00
				<i>Official-BB-SO-4/27/21</i>			62.00
				<i>10 E 1500 3190 30 300 000007</i>			62.00
Walker, Kellen J			118.00				

201

Invoice Listing

COUNTY OF GRUNDY SCHOOL DIST 111

Full Name	PO Number	Invoice Number	Batch	Description	Invoice Date	Check Number	Net Amount
Walmart Community /		6097652010099793	KAS	Items and Breakfast Items for IHSA Dance, Items for Boys Bowling, Items for Fam/Cons Science	03/24/2021	082333	374.35
				<i>Items for IHSA Dance</i>			50.23
				<i>Breakfast Items for IHSA Dance</i>			20.85
				<i>Items for IHSA Dance</i>			58.08
				<i>Breakfast Items for IHSA Dance</i>			35.80
				<i>Items for Boys Bowling, East</i>			21.85
				<i>Items for Boys Bowling, West</i>			17.99
				<i>Items for Fam/Cons Science</i>			29.82
				<i>Items for Fam/Cons Science</i>			139.73
				<i>10 E 1500 3900 30 300 000001</i>			50.23
				<i>10 E 1500 3900 30 300 000001</i>			20.85
				<i>10 E 1500 3900 30 300 000001</i>			58.08
				<i>10 E 1500 3900 30 300 000001</i>			35.80
				<i>10 E 1500 3900 30 300 000001</i>			21.85
				<i>10 E 1500 3900 30 300 000001</i>			17.99
				<i>10 E 1420 4100 09 300 000000</i>			29.82
				<i>10 E 1420 4100 09 300 000000</i>			139.73
Walmart Community / SYNCB			374.35				

Invoice Listing

COUNTY OF GRUNDY SCHOOL DIST 111

Full Name	PO Number	Invoice Number	Batch	Description	Invoice Date	Check Number	Net Amount
Waste Management Of		6165980-2007-4	KAS	Garbage Service - Central, Overage Service Fel, 2 yd. Fel, 6 yd. Compactor, 8 yd. Fel 4/1 to 4/30/21	03/31/2021	082334	2,833.25
				<i>Garbage Service - Central, Overage</i>			2,833.25
				<i>20 E 2540 3210 00 300 000000</i>			2,833.25
Waste Management Of		6166004-2007-2	KAS	Garbage Service - Central, 6 yd. Fel Rcy. 4/1 to 4/30/21	03/31/2021	082334	162.04
				<i>Garbage Service - Central, 6 yd. Fel</i>			162.04
				<i>20 E 2540 3210 00 300 000000</i>			162.04
Waste Management Of		6166781-2007-5	KAS	Garbage Service - South 4/1 to 4/30/21	03/31/2021	082334	4,449.60
				<i>Garbage Service - South 4/1 to 4/30/21</i>			203
				<i>20 E 2540 3210 00 302 000000</i>			4,449.60
Waste Management Of IL			7,444.89				
Weldstar Company		0001945541	KAS	Cylinder Rental	03/24/2021	9100000356	154.56
				<i>Cylinder Rental</i>			154.56
				<i>10 E 1400 4100 10 300 000001</i>			154.56
Weldstar Company		01941769	KAS	Cylinder Rental	03/10/2021	9100000356	755.82
				<i>Cylinder Rental</i>			755.82
				<i>10 E 1400 4100 10 300 000001</i>			755.82
Weldstar Company			910.38				

Invoice Listing

COUNTY OF GRUNDY SCHOOL DIST 111

Full Name	PO Number	Invoice Number	Batch	Description	Invoice Date	Check Number	Net Amount
Wesco Receivables		397581	KAS	Building Supplies - PVC, CTX BND STD, CTX ADAPT, T&B LOCKNUT, CRS DEGREE C, CTX CPLG, CRS HANGER, GEL, T&B CEMENT	03/24/2021	082335	450.72
				<i>Building Supplies - PVC, CTX BND STD,</i>			450.72
				<i>20 E 2540 4100 00 300 000001</i>			450.72
Wesco Receivables		397582	KAS	T&B PVC JUNC	03/24/2021	082335	484.05
				<i>T&B PVC JUNC</i>			484.05
				<i>20 E 2540 4100 00 300 000001</i>			484.05
Wesco Receivables		412030	KAS	Gel	03/31/2021	082335	38.80 204
				<i>Gel</i>			38.80
				<i>20 E 2540 4100 00 300 000001</i>			38.80
Wesco Receivables Corp			973.57				
White, Jackson	1032100138	85946 3/20/21	KAS	Football-FR-3-20-21	03/20/2021	082336	92.00
				<i>Football-FR-3-20-21</i>			92.00
				<i>10 E 1500 3190 30 300 000003</i>			92.00
White, Jackson			92.00				

Invoice Listing

COUNTY OF GRUNDY SCHOOL DIST 111

Full Name	PO Number	Invoice Number	Batch	Description	Invoice Date	Check Number	Net Amount
White, Tyler R		2011087 502.00	KAS	Mus470 Foundations of American Music - Illinois State University (no tuition for Mus452, Mus393.21, Tch401, Mus472)	07/12/2020	9100000377	370.00
				<i>Mus470 Foundations of American Music</i>			370.00
				10 E 1130 2300 00 300 000000			370.00
	White, Tyler R		370.00				

Invoice Listing

COUNTY OF GRUNDY SCHOOL DIST 111

Full Name	PO Number	Invoice Number	Batch	Description	Invoice Date	Check Number	Net Amount
Whitmore Ace		300099 3/31/21	KAS	Building Supplies - Central	03/31/2021	082337	1,741.78
				<i>109286 Shims Toilet, Ring Wax</i>			15.56
				<i>109310 Plugs</i>			10.36
				<i>109337 Chicago Key</i>			14.95
				<i>109338 Ant/Roach Raid, Ant Combat</i>			35.95
				<i>109382 Outlet Box, Blank Cover, Ground</i>			153.24
				<i>109388 Nipple Conduit, Screw, Strap,</i>			37.84
				<i>109390 Key Blank, Angle Broom,</i>			125.83
				<i>109406 Plug, Pntbrsh, Nipple, Vlv Ball,</i>			53.94
				<i>109417 M Copper, Splyfct, Supply Line,</i>			147.43
				<i>109426 Tailpieces, Cplg Str, Ptrap Flex</i>			19.96
				<i>109436 60W Led, Repair Valve</i>			35.97
				<i>109447 Mesh Strain, Wrench Pipe</i>			91.15
				<i>109465 Work Light Fluor, Wheel,</i>			59.75
				<i>109474 Elbw, Nipple, Pipe</i>			18.75
				<i>109498 Hardware, Thread Rod, Bar Flat,</i>			81.84
				<i>109515 Ace 2Cyc</i>			9.98
				<i>109516 Conduit, Clamp, Conn Liquid,</i>			126.71
				<i>109530 Tie Down</i>			39.98
							206

Invoice Listing

COUNTY OF GRUNDY SCHOOL DIST 111

Full Name	PO Number	Invoice Number	Batch	Description	Invoice Date	Check Number	Net Amount
				109556 Drill			249.98
				109559 Couple PVC, Rope			17.95
				109560 Sealr, Caulk			13.98
				109563 Surge Protector			84.95
				109573 Roller			16.77
				109580 Conduit, Wire, Box, Cover,			278.96
				20 E 2540 4100 00 300 000000			15.56
				20 E 2540 4100 00 300 000000			10.36
				20 E 2540 4100 00 300 000000			14.95
				20 E 2540 4100 00 300 000000			35.95
				20 E 2540 4100 00 300 000000			153.24
				20 E 2540 4100 00 300 000000			37.84
				20 E 2540 4100 00 300 000000			125.83
				20 E 2540 4100 00 300 000000			53.94
				20 E 2540 4100 00 300 000000			147.43
				20 E 2540 4100 00 300 000000			19.96
				20 E 2540 4100 00 300 000000			35.97
				20 E 2540 4100 00 300 000000			91.15
				20 E 2540 4100 00 300 000000			59.75
				20 E 2540 4100 00 300 000000			18.75

207

Invoice Listing

COUNTY OF GRUNDY SCHOOL DIST 111

<u>Full Name</u>	<u>PO Number</u>	<u>Invoice Number</u>	<u>Batch</u>	<u>Description</u>	<u>Invoice Date</u>	<u>Check Number</u>	<u>Net Amount</u>
				20 E 2540 4100 00 300 000000			81.84
				20 E 2540 4100 00 300 000000			9.98
				20 E 2540 4100 00 300 000000			126.71
				20 E 2540 4100 00 300 000000			39.98
				20 E 2540 4100 00 300 000000			249.98
				20 E 2540 4100 00 300 000000			17.95
				20 E 2540 4100 00 300 000000			13.98
				20 E 2540 4100 00 300 000000			84.95
				20 E 2540 4100 00 300 000000			16.77
				20 E 2540 4100 00 300 000000			278.96
							208

Invoice Listing

COUNTY OF GRUNDY SCHOOL DIST 111

Full Name	PO Number	Invoice Number	Batch	Description	Invoice Date	Check Number	Net Amount
Whitmore Ace		300242 3/31/21	KAS	Building Supplies - South	03/31/2021	082337	237.49
				109274 Wrench			18.99
				109285 Hoses, Work Lite Fluor			77.56
				109294 Packing Sheet			5.99
				109348 Filter, Vac Bag, Dryer Duct			34.97
				109409 Hardware			18.05
				109431 Anchor			59.97
				109482 Oil			3.99
				109548 Ant Control			17.97
				20 E 2540 4100 00 302 000000			18.99
				20 E 2540 4100 00 302 000000			77.56
				20 E 2540 4100 00 302 000000			5.99
				20 E 2540 4100 00 302 000000			34.97
				20 E 2540 4100 00 302 000000			18.05
				20 E 2540 4100 00 302 000000			59.97
				20 E 2540 4100 00 302 000000			3.99
				20 E 2540 4100 00 302 000000			17.97
							209

Invoice Listing

COUNTY OF GRUNDY SCHOOL DIST 111

Full Name	PO Number	Invoice Number	Batch	Description	Invoice Date	Check Number	Net Amount
Whitmore Ace		300304 3/31/21	KAS	Building Supplies - Bus Garage	03/31/2021	082337	63.11
				<i>109408 Batteries, Gloves</i>			35.16
				<i>109292 Spoons, Plates, Water</i>			14.97
				<i>109545 Sprayer, Water</i>			12.98
				<i>40 E 2554 3230 00 300 000000</i>			35.16
				<i>40 E 2552 4100 00 300 000001</i>			14.97
				<i>40 E 2554 3230 00 300 000000</i>			12.98
Whitmore Ace Hardware			2,042.38				
Williams, Edward	1032100190	49599 4/9/21	KAS	Official -BSOC-F-4/9/21	04/09/2021	082439	2100
				<i>Official -BSOC-F-4/9/21</i>			61.00
				<i>10 E 1500 3190 30 300 000001</i>			61.00
Williams, Edward			61.00				
Williams, Matthew D		2/17/21 Home Depot	KAS	PVC piping for training the fundamentals of Olympic lifts in Athletic Fitness from Home Depot	02/17/2021	9100000378	49.20
				<i>PVC piping for training the fundamentals</i>			49.20
				<i>10 E 1130 4100 50 300 000000</i>			49.20
Williams, Matthew D			49.20				

Invoice Listing

COUNTY OF GRUNDY SCHOOL DIST 111

Full Name	PO Number	Invoice Number	Batch	Description	Invoice Date	Check Number	Net Amount
Wilmington High School		2/21/21 Cheerleading	KAS	Competitive Cheerleading C V vs ICCA Cheer Invite	02/21/2021	082341	125.00
				<i>Competitive Cheerleading C V vs ICCA</i>			125.00
				<i>10 E 1500 3900 30 300 000000</i>			125.00
Wilmington High School			125.00				
Woods, Aaron	1032100134	61529 3/18/21	KAS	Girls Volleyball-JV&V-3/18/21 Please note new address of 20520 Erie Ct. Crest Hill, IL 60403	03/18/2021	082342	89.00
				<i>Girls Volleyball-JV&V-3/18/21</i>			89.00
				<i>10 E 1500 3190 30 300 000000</i>			89.00
Woods, Aaron	1032100253	61529 4/26/21	KAS	Official-BVB-V/JV-4/26/21	04/26/2021	082440	89.00 21
				<i>Official-BVB-V/JV-4/26/21</i>			89.00
				<i>10 E 1500 3190 30 300 000009</i>			89.00
Woods, Aaron			178.00				
Ybarra, Robert	1032100118	17679 3/13/21	KAS	Football - 3-13-21	03/13/2021	082343	77.00
				<i>Football - 3-13-21</i>			77.00
				<i>10 E 1500 3190 30 300 000003</i>			77.00
Ybarra, Robert			77.00				

Invoice Listing

COUNTY OF GRUNDY SCHOOL DIST 111

Full Name	PO Number	Invoice Number	Batch	Description	Invoice Date	Check Number	Net Amount
Zack, Steven	1032100176	80355 4/6/21	KAS	Official-GVB-FR-4-6-21	04/06/2021	082441	61.00
				<i>Official-GVB-FR-4-6-21</i>			<i>61.00</i>
				<i>10 E 1500 3190 30 300 000000</i>			<i>61.00</i>
Zack, Steven			61.00				
Total Number of Batch Invoices:				0			\$0.00
Total Number of Open Invoices:				0			\$0.00
Total Number of History Invoices:				502			\$1,033,881.36
Total Number of Update in Progress Batch Invoices:				0			\$0.00
Total Number of Update in Progress Batch Reversal Invoices:				0			\$0.00 212
Total Number of Reversal History Invoices:				0			\$0.00
Total Number of Deleted History Invoices:				0			\$0.00
Total Number of Batch Reversal Invoices:				0			\$0.00
Total Number of Unsubmitted Invoices:				0			\$0.00
Total Number of Awaiting for Approval Invoices:				0			\$0.00
Total Invoices:			502				1,033,881.36

Invoice Listing

COUNTY OF GRUNDY SCHOOL DIST 111

Full Name	PO Number	Invoice Number	Batch	Description	Invoice Date	Check Number	Net Amount
Masokas, Samantha		4/29/21 Prom	KAS	Prom Music	04/30/2021	026428	400.00
				<i>Prom Music</i>			<i>400.00</i>
				<i>10 E 1500 4100 70 300 000021</i>			<i>400.00</i>
Masokas, Samantha			400.00				
Raczykowski, Leo		4/29/21 Prom	KAS	DJ for Prom	04/30/2021	026429	1,400.00
				<i>DJ for Prom</i>			<i>1,400.00</i>
				<i>10 E 1500 4100 70 300 000021</i>			<i>1,400.00</i>
Raczykowski, Leo			1,400.00				
Total Number of Batch Invoices:				0			213 \$0.00
Total Number of Open Invoices:				0			\$0.00
Total Number of History Invoices:				2			\$1,800.00
Total Number of Update in Progress Batch Invoices:				0			\$0.00
Total Number of Update in Progress Batch Reversal Invoices:				0			\$0.00
Total Number of Reversal History Invoices:				0			\$0.00
Total Number of Deleted History Invoices:				0			\$0.00
Total Number of Batch Reversal Invoices:				0			\$0.00
Total Number of Unsubmitted Invoices:				0			\$0.00
Total Number of Awaiting for Approval Invoices:				0			\$0.00
Total Invoices:				2			1,800.00

Invoice Listing

COUNTY OF GRUNDY SCHOOL DIST 111

Full Name	PO Number	Invoice Number	Batch	Description	Invoice Date	Check Number	Net Amount
Blue Cross Blue Shield		550747984930	KAS	Minooka Community High School District 111, IL 1-015160, 5507466927, 3/1 - 3/31/21 Medical and Dental Insurance	03/31/2021	1257	364,573.03
				<i>IL 1-015160, 5507466927, 3/1 - 3/31/21</i>			314,561.64
				<i>IL 1-015160, 5507466927, 3/1 - 3/31/21</i>			6,012.21
				<i>IL 1-015160, 5507466927, 3/1 - 3/31/21</i>			1,380.87
				<i>IL 1-015160, 5507466927, 3/1 - 3/31/21</i>			24,984.14
				<i>IL 1-015160, 5507466927, 3/1 - 3/31/21</i>			16,612.94
				<i>IL 1-015160, 5507466927, 3/1 - 3/31/21</i>			809.15
				<i>IL 1-015160, 5507466927, 3/1 - 3/31/21</i>			20.59
				<i>IL 1-015160, 5507466927, 3/1 - 3/31/21</i>			191.49
				<i>10 E 1130 2220 00 000 000000</i>			314,561.64
				<i>20 E 1130 2220 00 000 000000</i>			6,012.21
				<i>40 E 1130 2220 00 000 000000</i>			1,380.87
				<i>80 E 1130 2220 00 000 000000</i>			24,984.14
				<i>10 E 1130 2230 00 000 000000</i>			16,612.94
				<i>20 E 1130 2230 00 000 000000</i>			809.15
				<i>40 E 1130 2230 00 000 000000</i>			20.59
				<i>80 E 1130 2230 00 000 000000</i>			191.49
Blue Cross Blue Shield of IL -			364,573.03				

214

Invoice Listing

COUNTY OF GRUNDY SCHOOL DIST 111

Full Name	PO Number	Invoice Number	Batch	Description	Invoice Date	Check Number	Net Amount
Total Number of Batch Invoices:			0				\$0.00
Total Number of Open Invoices:			0				\$0.00
Total Number of History Invoices:			1				\$364,573.03
Total Number of Update in Progress Batch Invoices:			0				\$0.00
Total Number of Update in Progress Batch Reversal Invoices:			0				\$0.00
Total Number of Reversal History Invoices:			0				\$0.00
Total Number of Deleted History Invoices:			0				\$0.00
Total Number of Batch Reversal Invoices:			0				\$0.00
Total Number of Unsubmitted Invoices:			0				\$0.00
Total Number of Awaiting for Approval Invoices:			0				\$0.00
Total Invoices:			1				364,573.03

Invoice Listing

COUNTY OF GRUNDY SCHOOL DIST 111

Full Name	PO Number	Invoice Number	Batch	Description	Invoice Date	Check Number	Net Amount
Connellan, Christine		4/28/21 Mealtime	KAS	Shane Connellan Mealtime Refund	04/28/2021	1625	38.50
				<i>Shane Connellan Mealtime Refund</i>			38.50
				<i>10 R 1612 0000 00 000 000000</i>			38.50
Connellan, Christine			38.50				
Dailey, Julissa		4/27/21 Mealtime	KAS	Matthew Dailey Mealtime Refund	04/27/2021	1626	49.35
				<i>Matthew Dailey Mealtime Refund</i>			49.35
				<i>10 R 1612 0000 00 000 000000</i>			49.35
Dailey, Julissa			49.35				
Scholtes, Stacey J		4/26/21 Mealtime	KAS	Marlo Scholtes Mealtime Refund	04/26/2021	1627	27.15
				<i>Marlo Scholtes Mealtime Refund</i>			27.15
				<i>10 R 1612 0000 00 000 000000</i>			27.15
Scholtes, Stacey J			27.15				

Invoice Listing

COUNTY OF GRUNDY SCHOOL DIST 111

Full Name	PO Number	Invoice Number	Batch	Description	Invoice Date	Check Number	Net Amount
Total Number of Batch Invoices:			0				\$0.00
Total Number of Open Invoices:			0				\$0.00
Total Number of History Invoices:			3				\$115.00
Total Number of Update in Progress Batch Invoices:			0				\$0.00
Total Number of Update in Progress Batch Reversal Invoices:			0				\$0.00
Total Number of Reversal History Invoices:			0				\$0.00
Total Number of Deleted History Invoices:			0				\$0.00
Total Number of Batch Reversal Invoices:			0				\$0.00
Total Number of Unsubmitted Invoices:			0				\$0.00
Total Number of Awaiting for Approval Invoices:			0				\$0.00
Total Invoices:			3				115.00

Invoice Listing

COUNTY OF GRUNDY SCHOOL DIST 111

Full Name	PO Number	Invoice Number	Batch	Description	Invoice Date	Check Number	Net Amount
5 Alarm Fireworks Co.		4/26/21 Senior Sunset	KAS	Fireworks Display	04/26/2021	22571	3,000.00
				<i>Fireworks Display</i>			<i>3,000.00</i>
				<i>11 E 1999 4100 70 300 900010</i>			<i>3,000.00</i>
5 Alarm Fireworks Co.			3,000.00				
Bezaire, Ava		4/23/21 Senior Sunset	KAS	Senior Awards from Walmart	04/23/2021	22572	14.96
				<i>Senior Awards from Walmart</i>			<i>14.96</i>
				<i>11 E 1999 4100 70 300 900010</i>			<i>14.96</i>
Bezaire, Ava			14.96				
Boombah		661539	KAS	Freshman Practice Jerseys	04/27/2021	22573	218 599.78
				<i>Freshman Practice Jerseys</i>			<i>599.78</i>
				<i>11 E 1999 4100 30 300 910016</i>			<i>599.78</i>
Boombah			599.78				
BSN Sports Inc		912493159	KAS	Field Material and Equipment	04/27/2021	22574	961.75
				<i>Field Material and Equipment</i>			<i>961.75</i>
				<i>11 E 1999 4100 30 300 910004</i>			<i>961.75</i>
BSN Sports Inc			961.75				

Invoice Listing

COUNTY OF GRUNDY SCHOOL DIST 111

Full Name	PO Number	Invoice Number	Batch	Description	Invoice Date	Check Number	Net Amount
Charlebois, Gabriella		4/28/21 Football Filming	KAS	Filming during Football Games	04/28/2021	22575	395.00
				<i>Filming during Football Games</i>			395.00
				<i>11 E 1999 4100 30 300 910002</i>			395.00
Charlebois, Gabriella			395.00				
Gumabong, Alayna		4/23/21 Sr. Awards	KAS	Sr. Award Gifts from Target, Five Below	04/23/2021	22576	21.15
				<i>Sr. Award Gifts from Target, Five Below</i>			21.15
				<i>11 E 1999 4100 70 300 900010</i>			21.15
Gumabong, Alayna			21.15				
Petrovic, Jeffrey		4/26/21 Baseball Dinner	KAS	Team Dinner from Little Caesars	04/26/2021	22577	219 51.00
				<i>Team Dinner from Little Caesars</i>			51.00
				<i>11 E 1999 4100 30 300 910004</i>			51.00
Petrovic, Jeffrey			51.00				
Reed, Lydia		4/23/21 Sr. Awards	KAS	Sr. Award Gifts from Party City, Five BELOW	04/23/2021	22578	21.08
				<i>4391913hay@comcast.net</i>			21.08
				<i>11 E 1999 4100 70 300 900010</i>			21.08
Reed, Lydia			21.08				

Invoice Listing

COUNTY OF GRUNDY SCHOOL DIST 111

Full Name	PO Number	Invoice Number	Batch	Description	Invoice Date	Check Number	Net Amount
Sublime Wear USA		S12698	KAS	Prizes for Winners of the Minooka Team Series (2 hoodies)	04/28/2021	22579	210.36
				<i>Prizes for Winners of the Minooka Team</i>			<i>210.36</i>
				<i>11 E 1999 4100 70 300 900032</i>			<i>210.36</i>
Sublime Wear USA			210.36				
Total Number of Batch Invoices:			0				\$0.00
Total Number of Open Invoices:			0				\$0.00
Total Number of History Invoices:			9				\$5,275.08
Total Number of Update in Progress Batch Invoices:			0				\$0.00
Total Number of Update in Progress Batch Reversal Invoices:			0				\$0.00 220
Total Number of Reversal History Invoices:			0				\$0.00
Total Number of Deleted History Invoices:			0				\$0.00
Total Number of Batch Reversal Invoices:			0				\$0.00
Total Number of Unsubmitted Invoices:			0				\$0.00
Total Number of Awaiting for Approval Invoices:			0				\$0.00
Total Invoices:			9				5,275.08

Payroll Summaries

Payroll Run Description: 03-30-21 Payroll; Covid; 3-15-21 Payroll

COUNTY OF GRUNDY SCHOOL DIST 111

Payroll Run	Pay Gross	Fed Gross	Fed Tax	State Gross	State Tax	SS Gross	SS Tax	Med Gross	Med Tax
3/15/21 - 3-15-21 Payroll	782,729.11	726,391.79	76,826.02	726,391.79	35,030.03	152,403.53	9,449.06	753,769.39	10,929.61
3/18/21 - Covid	6,000.00	5,797.50	406.18	5,797.50	252.69	4,500.00	279.00	6,000.00	87.00
3/30/21 - 03-30-21 Payroll	808,154.88	751,890.48	78,906.75	751,890.48	36,250.44	165,351.64	10,251.85	779,184.36	11,298.08
Totals:	1,596,883.99	1,484,079.77	156,138.95	1,484,079.77	71,533.16	322,255.17	19,979.91	1,538,953.75	22,314.69

IMPREST

3/31/2021

	EDUCATION	BUILDING	BOND & INT	TRANSPORTATION
BEG BALANCE	18637.20	100.00	0.00	16184.00
RECEIPTS				
DEPOSITS	0.00	0.00		0.00
DEPOSITS				
VOID				
TOTAL RECEIPTS	0.00	0.00	0.00	0.00
DISBURSEMENTS				
AP CHECK	4873.30	0.00		
TOTAL DISBURSEMENTS	4873.30	0.00	0.00	0.00
ENDING BALANCE	13763.90	100.00	0.00	16184.00
BANK BALANCE	38649.58			LEDGER BALANCE
OUTSTANDING CHECKS	7468.40			OUTSTANDING CHECKS
DIFFERENCE	1133.28			VOID
REGISTER BALANCE	30047.90 B			DIFFERENCE
				BANK BALANCE

SS/IMRF	TORT	TOTAL
0.00	0.00	34921.20
		0.00
0.00		0.00
		0.00
		0.00
0.00	0.00	0.00
		4873.30
0.00	0.00	4873.30
0.00	0.00	30047.90
30047.90		
7468.40		
1133.28		
38649.58	BALANCE	

AP Check Register

AP Run: 3/24/21 AP Imprest — Post Date: 2021-03-24 — AP Run Type: R

COUNTY OF GRUNDY SCHOOL DIST 111

Check Date	Check Number	Payment Type	Name	Check Amount	
03/24/2021	026426	Check	Grand Ball Costumes	4,863.30	
Invoice Number	Description	Invoice Date	Invoice Amount	Account	Amount
3/24/21 Musical	Musical Costume Rental	03/24/2021	4,863.30	10 E 1500 3000 70 300 000000	4,863.30
03/24/2021	026427	Check	Jesse White, Secretary of State - Dept. of Business Services	10.00	
Invoice Number	Description	Invoice Date	Invoice Amount	Account	Amount
N 7173-099-9 2021	N 7173-099-9 Annual Report - District #111 Foundation for Educational Excellence	03/23/2021	10.00	10 E 2310 4100 00 300 000000	10.00
				Total:	\$4,873.30

3/24/21 AP Imprest Summary

Type	Count	Amount
Regular	2	4,873.30
ACH Checks:	0	0.00
Wire Transfers:	0	0.00
Epayables:	0	0.00
Total:	2	\$4,873.30

AP Check Register

Summary by Fund

COUNTY OF GRUNDY SCHOOL DIST 111

<u>Fund</u>	<u>Total</u>
10 - Education Fund	4,873.30
	\$4,873.30

225

Balance Sheet Detail by Fund

March 2020-2021		COUNTY OF GRUNDY SCHOOL DIST 111				
Fund	Account	Account Description	Beginning Balance	Debit	Credit	Ending Balance
11 - Activity Fund						
A - Asset						
	11 A 1260 0000 00 000 000000	CASH-ACTIVITIES	\$279,919.46	\$830.97	\$12,352.47	\$268,397.96
	11 A 1261 0000 00 000 000000	COADY SCHOLARSHIP	\$398,795.33	\$6.82	\$0.00	\$398,802.15
Totals for: 11 A - Asset			\$678,714.79	\$837.79	\$12,352.47	\$667,200.11
L - Liability						
	11 L 4310 0000 00 000 000000	AP Liability	\$0.00	\$12,352.47	\$12,352.47	\$0.00
Totals for: 11 L - Liability			\$0.00	\$12,352.47	\$12,352.47	\$0.00
Q - Equity						
	11 Q 7150 0000 01 000 900000	COADY SCHOLARSHIP	(\$398,795.33)	\$0.00	\$6.82	(\$398,802.15)
	11 Q 7150 0000 30 300 910001	SPORTS - ATHLETIC HALL OF FAME	(\$5,460.86)	\$0.00	\$0.00	(\$5,460.86)
	11 Q 7150 0000 30 300 910002	SPORTS - ATHLETIC POP	(\$3,674.74)	\$1,872.50	\$6.35	(\$1,808.59)
	11 Q 7150 0000 30 300 910003	SPORTS - ATHLETIC TRAINING	(\$1,319.36)	\$0.00	\$0.00	(\$1,319.36)
	11 Q 7150 0000 30 300 910004	SPORTS - BASEBALL	(\$34,452.43)	\$75.00	\$0.00	(\$34,377.43)
	11 Q 7150 0000 30 300 910005	SPORTS - BOYS BASKETBALL	(\$4,493.60)	\$500.00	\$0.00	(\$3,993.60)
	11 Q 7150 0000 30 300 910006	SPORTS - BOYS BOWLING	(\$2,593.05)	\$0.00	\$0.00	(\$2,593.05)
	11 Q 7150 0000 30 300 910007	SPORTS - BOYS GOLF	(\$2,548.18)	\$0.00	\$0.00	(\$2,548.18)
	11 Q 7150 0000 30 300 910008	SPORTS - BOYS SOCCER	(\$237.70)	\$10.88	\$0.00	(\$226.82)
	11 Q 7150 0000 30 300 910009	SPORTS - BOYS TENNIS	(\$1,636.90)	\$0.00	\$0.00	(\$1,636.90)
	11 Q 7150 0000 30 300 910010	SPORTS - BOYS TRACK	(\$5,713.58)	\$0.00	\$0.00	(\$5,713.58)
	11 Q 7150 0000 30 300 910011	SPORTS - BOYS VOLLEYBALL	(\$6,762.71)	\$0.00	\$0.00	(\$6,762.71)

Balance Sheet Detail by Fund

March 2020-2021		COUNTY OF GRUNDY SCHOOL DIST 111				
Fund	Account	Account Description	Beginning Balance	Debit	Credit	Ending Balance
11 - Activity Fund						
Q - Equity						
	11 Q 7150 0000 30 300 910012	SPORTS - CHEERLEADERS	(\$7,535.23)	\$1,536.50	\$0.00	(\$5,998.73)
	11 Q 7150 0000 30 300 910013	SPORTS - CROSS COUNTY CO ED	(\$8,432.67)	\$86.38	\$0.00	(\$8,346.29)
	11 Q 7150 0000 30 300 910014	SPORTS - FOOTBALL	(\$7,697.54)	\$3,392.59	\$0.00	(\$4,304.95)
	11 Q 7150 0000 30 300 910015	SPORTS - FOOTBALL JERSEYS	(\$4,065.97)	\$0.00	\$0.00	(\$4,065.97)
	11 Q 7150 0000 30 300 910016	SPORTS - GIRLS BASKETBALL	(\$4,767.45)	\$0.00	\$0.00	(\$4,767.45)
	11 Q 7150 0000 30 300 910017	SPORTS - GIRLS BOWLING	(\$2,025.57)	\$0.00	\$0.00	(\$2,025.57)
	11 Q 7150 0000 30 300 910018	SPORTS - GIRLS GOLF	(\$1,413.85)	\$0.00	\$0.00	(\$1,413.85)
	11 Q 7150 0000 30 300 910019	SPORTS - GIRLS SOCCER	(\$1,346.18)	\$0.00	\$0.00	(\$1,346.18)
	11 Q 7150 0000 30 300 910020	SPORTS - GIRLS TENNIS	(\$1,621.95)	\$0.00	\$0.00	(\$1,621.95)
	11 Q 7150 0000 30 300 910021	SPORTS - GIRLS TRACK	(\$4,161.00)	\$300.00	\$0.00	(\$3,861.00)
	11 Q 7150 0000 30 300 910022	SPORTS - GIRLS VOLLEYBALL	(\$1,276.50)	\$535.00	\$0.00	(\$741.50)
	11 Q 7150 0000 30 300 910023	SPORTS - LACROSSE	(\$243.07)	\$0.00	\$0.00	(\$243.07)
	11 Q 7150 0000 30 300 910024	SPORTS - OUTDOOR ED TRIP	(\$5,212.00)	\$0.00	\$0.00	(\$5,212.00)
	11 Q 7150 0000 30 300 910025	SPORTS - POMS	(\$520.92)	\$520.00	\$300.00	(\$300.92)
	11 Q 7150 0000 30 300 910026	SPORTS - SOFTBALL	\$1,109.57	\$0.00	\$0.00	\$1,109.57
	11 Q 7150 0000 30 300 910027	SPORTS - SWIMMING B&G	(\$760.49)	\$0.00	\$0.00	(\$760.49)
	11 Q 7150 0000 30 300 910028	SPORTS - WRESTLING	(\$3,266.12)	\$0.00	\$0.00	(\$3,266.12)
	11 Q 7150 0000 70 300 900001	ACTIVITIES - POP	(\$2,167.34)	\$0.00	\$16.14	(\$2,183.48)

Balance Sheet Detail by Fund

March 2020-2021		COUNTY OF GRUNDY SCHOOL DIST 111				
Fund	Account	Account Description	Beginning Balance	Debit	Credit	Ending Balance
11 - Activity Fund						
	Q - Equity					
	11 Q 7150 0000 70 300 900002	ACTIVITIES - ART CLUB	(\$692.10)	\$0.00	\$0.00	(\$692.10)
	11 Q 7150 0000 70 300 900003	ACTIVITIES - ATHLETIC LEADERSHIP	(\$342.50)	\$0.00	\$0.00	(\$342.50)
	11 Q 7150 0000 70 300 900004	ACTIVITIES - BAND	(\$126.00)	\$0.00	\$0.00	(\$126.00)
	11 Q 7150 0000 70 300 900005	ACTIVITIES - CHESS	(\$421.00)	\$0.00	\$0.00	(\$421.00)
	11 Q 7150 0000 70 300 900006	ACTIVITIES - CHOIR PROJECTS	(\$62.29)	\$0.00	\$0.00	(\$62.29)
	11 Q 7150 0000 70 300 900007	ACTIVITIES - CHORUS	(\$2,494.82)	\$0.00	\$0.00	(\$2,494.82)
	11 Q 7150 0000 70 300 900010	ACTIVITIES - CLASS OF 2021	(\$3,774.97)	\$0.00	\$1.06	(\$3,776.03)
	11 Q 7150 0000 70 300 900011	ACTIVITIES - CLASS OF 2022	(\$1,534.21)	\$35.00	\$1.06	(\$1,500.27)
	11 Q 7150 0000 70 300 900012	ACTIVITIES - CLASS OF 2023	(\$1,000.00)	\$509.00	\$0.00	(\$491.00)
	11 Q 7150 0000 70 300 900013	ACTIVITIES - CLASS OF 2024	(\$1,000.00)	\$20.00	\$0.00	(\$980.00)
	11 Q 7150 0000 70 300 900014	ACTIVITIES - COMMUNITY GARDEN	(\$615.39)	\$0.00	\$0.00	(\$615.39)
	11 Q 7150 0000 70 300 900015	ACTIVITIES - CULINARY ARTS	(\$816.30)	\$0.00	\$0.00	(\$816.30)
	11 Q 7150 0000 70 300 900017	ACTIVITIES - DREAM	(\$500.90)	\$0.00	\$0.00	(\$500.90)
	11 Q 7150 0000 70 300 900018	ACTIVITIES - FASHION MERCHANDISING	(\$223.31)	\$0.00	\$0.00	(\$223.31)
	11 Q 7150 0000 70 300 900019	ACTIVITIES - FCCLA	(\$187.80)	\$0.00	\$0.00	(\$187.80)
	11 Q 7150 0000 70 300 900020	ACTIVITIES - FFA	(\$3,696.02)	\$0.00	\$0.00	(\$3,696.02)
	11 Q 7150 0000 70 300 900021	ACTIVITIES - FRENCH NHS	(\$305.91)	\$0.00	\$0.00	(\$305.91)
	11 Q 7150 0000 70 300 900022	ACTIVITIES - FUTURE BUSINESS LEADERS	(\$140.86)	\$0.00	\$0.00	(\$140.86)

Balance Sheet Detail by Fund

March 2020-2021		COUNTY OF GRUNDY SCHOOL DIST 111				
Fund	Account	Account Description	Beginning Balance	Debit	Credit	Ending Balance
11 - Activity Fund						
Q - Equity						
	11 Q 7150 0000 70 300 900023	ACTIVITIES - I.O.T.A.	(\$2,706.38)	\$0.00	\$0.00	(\$2,706.38)
	11 Q 7150 0000 70 300 900024	ACTIVITIES - INDIAN CLIMBING CLUB	(\$1,216.86)	\$0.00	\$0.00	(\$1,216.86)
	11 Q 7150 0000 70 300 900025	ACTIVITIES - INDIAN NATION	(\$90.21)	\$0.00	\$0.00	(\$90.21)
	11 Q 7150 0000 70 300 900026	ACTIVITIES - INT'L CLUB	(\$755.31)	\$0.00	\$0.00	(\$755.31)
	11 Q 7150 0000 70 300 900027	ACTIVITIES - INT'L THESPIANS	(\$11,850.52)	\$0.00	\$0.00	(\$11,850.52)
	11 Q 7150 0000 70 300 900028	ACTIVITIES - INTERACT	(\$215.97)	\$0.00	\$0.00	(\$215.97)
	11 Q 7150 0000 70 300 900029	ACTIVITIES - INVESTMENT CLUB	(\$108.16)	\$0.00	\$0.00	(\$108.16)
	11 Q 7150 0000 70 300 900030	ACTIVITIES - JUDO	(\$13,550.21)	\$0.00	\$0.00	(\$13,550.21)
	11 Q 7150 0000 70 300 900031	ACTIVITIES - KALEIDOSOPE	(\$1,094.07)	\$0.00	\$0.00	(\$1,094.07)
	11 Q 7150 0000 70 300 900032	ACTIVITIES - MAC	(\$8,866.84)	\$1,284.65	\$0.00	(\$7,582.19)
	11 Q 7150 0000 70 300 900033	ACTIVITIES - MATH TEAM	(\$230.00)	\$0.00	\$0.00	(\$230.00)
	11 Q 7150 0000 70 300 900034	ACTIVITIES - MCHS BOOK CLUB	(\$598.77)	\$0.00	\$0.00	(\$598.77)
	11 Q 7150 0000 70 300 900035	ACTIVITIES - MEMORIAL GARDEN	(\$888.23)	\$0.00	\$0.00	(\$888.23)
	11 Q 7150 0000 70 300 900036	ACTIVITIES - MUSICAL	(\$4,011.20)	\$0.00	\$0.00	(\$4,011.20)
	11 Q 7150 0000 70 300 900037	ACTIVITIES - NEEDY FAMILIES	(\$1,204.56)	\$0.00	\$0.00	(\$1,204.56)
	11 Q 7150 0000 70 300 900038	ACTIVITIES - NHS	(\$166.88)	\$0.00	\$0.00	(\$166.88)
	11 Q 7150 0000 70 300 900039	ACTIVITIES - ORCHESIS	(\$6,255.19)	\$0.00	\$0.00	(\$6,255.19)
	11 Q 7150 0000 70 300 900040	ACTIVITIES - PAC RESTORATION	(\$1,096.81)	\$0.00	\$0.00	(\$1,096.81)

Balance Sheet Detail by Fund

March 2020-2021		COUNTY OF GRUNDY SCHOOL DIST 111				
Fund	Account	Account Description	Beginning Balance	Debit	Credit	Ending Balance
11 - Activity Fund						
Q - Equity						
	11 Q 7150 0000 70 300 900041	ACTIVITIES - PERCUSSION	(\$3,490.89)	\$0.00	\$0.00	(\$3,490.89)
	11 Q 7150 0000 70 300 900043	ACTIVITIES - PPC	(\$392.26)	\$0.00	\$0.00	(\$392.26)
	11 Q 7150 0000 70 300 900044	ACTIVITIES - SADD	(\$381.95)	\$0.00	\$0.00	(\$381.95)
	11 Q 7150 0000 70 300 900045	ACTIVITIES - SCHOLASTIC BOWL	(\$400.47)	\$0.00	\$0.00	(\$400.47)
	11 Q 7150 0000 70 300 900046	ACTIVITES - SPANISH NHS	(\$226.32)	\$0.00	\$0.00	(\$226.32)
	11 Q 7150 0000 70 300 900047	ACTIVITIES - SPEECH	(\$3,698.13)	\$0.00	\$0.00	(\$3,698.13)
	11 Q 7150 0000 70 300 900048	ACTIVITIES - STUDENT COUNCIL	(\$26,374.64)	\$1,674.97	\$0.00	(\$24,699.67)
	11 Q 7150 0000 70 300 900049	ACTIVITIES - TSA	(\$1,322.31)	\$0.00	\$0.00	(\$1,322.31)
	11 Q 7150 0000 70 300 900050	ACTIVITIES - UNDERWATER ROBOTIC	(\$181.93)	\$0.00	\$0.00	(\$181.93)
	11 Q 7150 0000 70 300 900051	ACTIVITIES - WINTERGUARD	(\$6,395.06)	\$0.00	\$0.00	(\$6,395.06)
	11 Q 7150 0000 70 300 900052	ACTIVITIES - WYSE	(\$418.94)	\$0.00	\$0.00	(\$418.94)
	11 Q 7150 0000 70 300 900053	ACTIVITIES - YEARBOOK	(\$24,135.25)	\$0.00	\$0.00	(\$24,135.25)
	11 Q 7150 0000 70 300 900055	CYBRARY	(\$1,238.29)	\$0.00	\$0.00	(\$1,238.29)
	11 Q 7150 0000 70 300 900056	FACULTY POP	(\$2,559.04)	\$0.00	\$6.36	(\$2,565.40)
	11 Q 7150 0000 70 300 900057	PROJECT INDIAN	(\$2,085.53)	\$0.00	\$0.00	(\$2,085.53)
	11 Q 7150 0000 70 300 900058	PROM	(\$5,220.00)	\$0.00	\$0.00	(\$5,220.00)
	11 Q 7150 0000 70 300 900059	SCHOLARSHIP	(\$4,249.91)	\$0.00	\$500.00	(\$4,749.91)

Balance Sheet Detail by Fund

March 2020-2021		COUNTY OF GRUNDY SCHOOL DIST 111				
Fund	Account	Account Description	Beginning Balance	Debit	Credit	Ending Balance
11 - Activity Fund						
	Q - Equity					
	11 Q 7150 0000 70 300 900060	TV PRODUCTION	(\$10.60)	\$0.00	\$0.00	(\$10.60)
Totals for: 11 Q - Equity			(\$678,714.79)	\$12,352.47	\$837.79	(\$667,200.11)
Totals for Fund: 11 - Activity Fund			\$0.00	\$25,542.73	\$25,542.73	\$0.00
			Beginning Balance	Debit	Credit	Ending Balance
Totals for: A - Asset			\$678,714.79	\$837.79	\$12,352.47	\$667,200.11
Totals for: L - Liability			\$0.00	\$12,352.47	\$12,352.47	\$0.00
Totals for: Q - Equity			(\$678,714.79)	\$12,352.47	\$837.79	(\$667,200.11)
Grand Totals:			\$0.00	\$25,542.73	\$25,542.73	\$0.00

Input Report Date 3/31/2021

Cash and Investments Report

	Education	Oper/ Maint.	Debt Service *	Transporation	IMRF/ Soc Sec	Capital **	Working Cash	Tort	Life Safety	Total	Fund 11 Activities	Total Funds
Checking	\$1,038,343.06	\$234,879.74	\$1,305,500.72	\$1,077,752.40	\$249,148.87	\$15,868.60	\$632,379.54	\$232,119.30	(\$2,709,846.41)	\$2,076,145.82	\$268,397.96	\$2,344,543.78
Food Service Account	\$681,839.89									\$681,839.89	0	\$681,839.89
Imprest	\$13,763.90	\$100.00		\$16,184.00						\$30,047.90	0	\$30,047.90
Insurance Account	\$1,373,898.60	\$202,679.51		\$74,134.00				(\$23,927.42)		\$1,626,784.69	0	\$1,626,784.69
PMA Cash Account	\$10,773.46	\$1,648,007.29	(\$921,356.84)	\$2,051,006.81	(\$66,859.68)	\$0.00	\$1,602,599.58	\$1,651,162.90	\$617,513.90	\$6,592,847.42	0	\$6,592,847.42
IPPIP	\$1,344,610.46	\$848,194.36	\$0.00	\$0.00	\$331,414.70	\$0.00	\$183,421.18	\$0.00	\$0.00	\$2,707,640.70	0	\$2,707,640.70
Total Cash accounts	\$4,463,229.37	\$2,933,860.90	\$384,143.88	\$3,219,077.21	\$513,703.89	\$15,868.60	\$2,418,400.30	\$1,859,354.78	(\$2,092,332.51)	\$13,715,306.42	\$268,397.96	\$13,983,704.38
PMA Investments	\$5,196,360.19	\$1,785,268.06	\$2,709,321.78	\$1,057,529.14	\$276,145.65	\$377,053.61	\$12,827,282.37	\$617,971.86	\$3,715,551.50	\$28,562,484.16	398,802.15	28,961,286.31
PMA 101 Investments	\$4916,325.92	\$1,108,234.18	\$2,425,814.36	\$523,796.34	\$258,011.36	\$325,000.00	\$195,401.67	\$368,266.36	\$218,779.56	\$10,339,629.75	-	\$10,339,629.75
PMA 62 (Working Cash)						\$0.00				\$0.00	-	\$0.00
PMA 202						\$0.00				\$0.00	-	\$0.00
PMA 203 - 2006 Bond			\$129,297.75							\$129,297.75	-	\$129,297.75
PMA 65 (Capital)										\$0.00	-	\$0.00
US Bank	\$615,000.00									\$615,000.00	-	\$615,000.00
PMA 205 Working Cash							\$12,552,774.57			\$12,552,774.57	-	\$12,552,774.57
PMA 68										\$0.00	0	\$0.00
PMA 104 - General Reserve	\$280,034.27	\$677,033.88	\$154,209.67	\$533,732.80	\$18,134.29	\$52,053.61	\$79,106.13	\$249,705.50	\$450,557.13	\$2,494,567.28	0	\$2,494,567.28
PMA 208 - Health Life Safety									\$3,046,214.81	\$3,046,214.81	0	\$3,046,214.81
PMA 209 - Capital						\$6,176,996.88				\$6,176,996.88	0	\$6,176,996.88
Private Bank Investments	\$623,874.73	\$1,377.63	\$108,449.16	\$148,519.77	\$7,043.29	\$0.00	\$0.00	\$0.00	\$0.00	\$889,264.58	0	\$889,264.58
PMA 103 - Coady Scholarship										\$0.00	398802.15	\$398,802.15
Total Investments	\$6,435,234.92	\$1,786,645.69	\$2,817,770.94	\$1,206,048.91	\$283,188.94	\$6,554,050.49	\$12,827,282.37	\$617,971.86	\$3,715,551.50	\$36,243,745.62	398,802.15	\$36,642,547.77
Total Cash & Investments	\$10,898,464.29	\$4,720,506.59	\$3,201,914.82	\$4,425,126.12	\$796,892.83	\$6,569,919.09	\$15,245,682.67	\$2,477,326.64	\$1,623,218.99	\$49,959,052.04	\$667,200.11	\$50,626,252.15

	Education	Oper/ Maint.	Debt Service *	Transportation	IMRF/ Soc Sec	Capital **	Working Cash	Tort	Life Safety	Total
Checking	\$1,038,343	\$234,880	\$1,305,501	\$1,077,752	\$249,149	\$15,869	\$632,380	\$232,119	(\$2,709,846)	\$ 2,076,146
Food Service Account	\$681,840	\$0	\$0	\$0	\$0	\$0	\$0	\$0	\$0	\$ 681,840
Imprest	\$13,764	\$100	\$0	\$16,184	\$0	\$0	\$0	\$0	\$0	\$ 30,048
Insurance Account	\$1,373,899	\$202,680	\$0	\$74,134	\$0	\$0	\$0	(\$23,927)	\$0	\$ 1,626,785
PMA Cash Account	\$10,773	\$1,648,007	(\$921,357)	\$2,051,007	(\$66,860)	\$0	\$1,602,600	\$1,651,163	\$617,514	\$ 6,592,847
IPTIP	\$1,344,610	\$848,194	\$0	\$0	\$331,415	\$0	\$183,421	\$0	\$0	\$ 2,707,641
Total Cash accounts	\$4,463,229	\$2,933,861	\$384,144	\$3,219,077	\$513,704	\$15,869	\$2,418,400	\$1,859,355	(\$2,092,333)	\$ 13,715,306
Total Investments	\$6,435,235	\$1,786,646	\$2,817,771	\$1,206,049	\$283,189	\$6,554,050	\$12,827,282	\$617,972	\$3,715,552	\$ 36,243,746
Total Cash & Investme	\$10,898,464	\$4,720,507	\$3,201,915	\$4,425,126	\$796,893	\$6,569,919	\$15,245,683	\$2,477,327	\$1,623,219	\$ 49,959,052

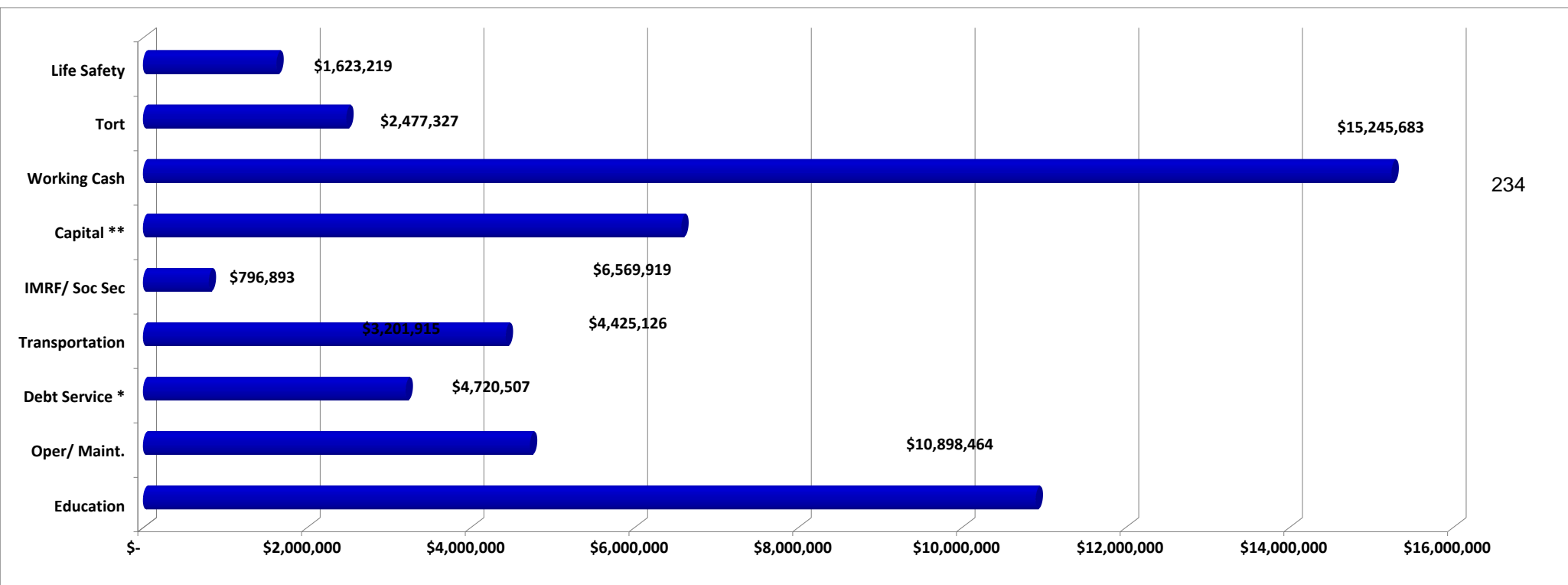

	Education	Oper/ Maint.	Debt Service *	Transportatio n	IMRF/ Soc Sec	Capital **	Working Cash	Tort	Life Safety	Total
Checking	\$1,038,343	\$234,880	\$1,305,501	\$1,077,752	\$249,149	\$15,869	\$632,380	\$232,119	(\$2,709,846)	\$ 2,076,146
Food Service Account	\$681,840									\$ 681,840
Imprest	\$13,764	\$100	\$0	\$16,184	\$0	\$0	\$0	\$0	\$0	\$ 30,048
Insurance Account	\$1,373,899									\$ 1,373,899
PMA Cash Account	\$10,773	\$1,648,007	(\$921,357)	\$2,051,007	(\$66,860)	\$0	\$1,602,600	\$1,651,163	\$617,514	\$ 6,592,847
IPTIP	\$1,344,610	\$848,194	\$0	\$0	\$331,415	\$0	\$183,421	\$0	\$0	\$ 2,707,641
Total Cash accounts	\$4,463,229	\$2,731,181	\$384,144	\$3,144,943	\$513,704	\$15,869	\$2,418,400	\$1,883,282	(\$2,092,333)	\$ 13,462,420
Total Investments	\$6,435,235	\$1,786,646	\$2,817,771	\$1,206,049	\$283,189	\$6,554,050	\$12,827,282	\$617,972	\$3,715,552	\$ 36,243,746
Total Cash & Investmer	\$10,898,464	\$4,517,827	\$3,201,915	\$4,350,992	\$796,893	\$6,569,919	\$15,245,683	\$2,501,254	\$1,623,219	\$ 49,706,166
Percent invested	59%	40%	88%	28%	36%	100%	84%	25%	229%	73%

Graph Data

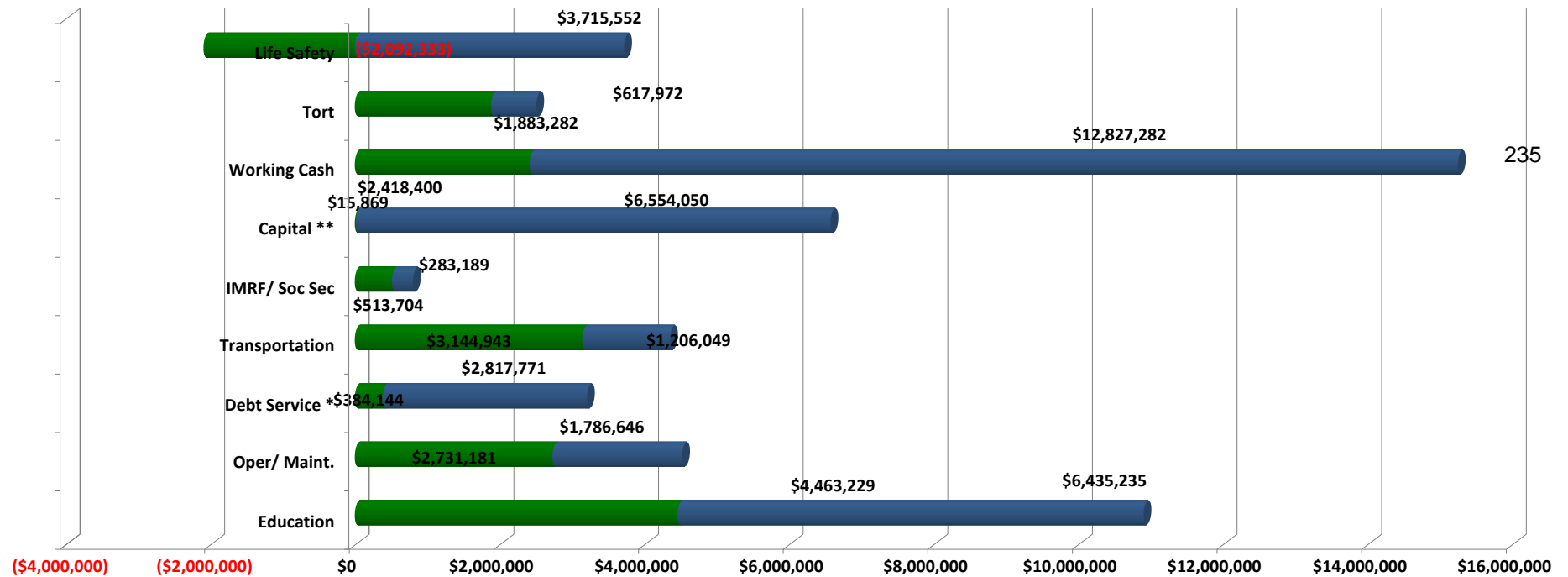

Expenditure Report

Fiscal Year: 2020-2021
Month: March

COUNTY OF GRUNDY SCHOOL DIST 111

Fund Description	Account Number	Revised Budget	MTD Activity	Encumbrance	Pending Activity	Available Funds	Year to Date Activity	Percent of Budget Used
Education Fund	10 E 1130 1000 00 000 000000	71,738.00	5,517.92	0.00	0.00	31,688.42	40,049.58	55.83
Education Fund	10 E 1130 1100 00 300 000000	0.00	0.00	0.00	0.00	0.00	0.00	0.00
Education Fund	10 E 1130 1100 00 300 000001	7,000.00	0.00	0.00	0.00	7,000.00	0.00	0.00
Education Fund	10 E 1130 1100 00 300 000002	0.00	0.00	0.00	0.00	0.00	0.00	0.00
Education Fund	10 E 1130 1100 02 300 000000	180,512.00	15,042.68	0.00	0.00	45,866.29	134,645.71	74.59
Education Fund	10 E 1130 1100 05 300 000000	1,525,409.00	127,561.86	0.00	0.00	381,839.26	1,143,569.74	74.97
Education Fund	10 E 1130 1100 06 300 000000	761,586.00	63,565.58	0.00	0.00	201,650.67	559,935.33	73.52
Education Fund	10 E 1130 1100 11 300 000000	1,413,807.00	117,817.30	0.00	0.00	365,592.11	1,048,214.89	74.14
Education Fund	10 E 1130 1100 12 300 000000	281,815.00	23,599.66	0.00	0.00	71,676.68	210,138.32	74.57
Education Fund	10 E 1130 1100 13 300 000000	1,345,048.00	112,237.40	0.00	0.00	344,091.21	1,000,956.79	74.42
Education Fund	10 E 1130 1100 15 300 000000	1,259,428.00	105,102.42	0.00	0.00	318,221.58	941,206.42	74.73
Education Fund	10 E 1130 1100 21 300 000000	0.00	0.00	0.00	0.00	0.00	0.00	0.00
Education Fund	10 E 1130 1100 21 300 000001	0.00	0.00	0.00	0.00	0.00	0.00	0.00
Education Fund	10 E 1130 1100 27 300 000000	658,685.00	54,890.46	0.00	0.00	159,004.83	499,680.17	75.86
Education Fund	10 E 1130 1100 50 300 000000	1,109,505.00	92,483.78	0.00	0.00	281,742.88	827,762.12	74.61
Education Fund	10 E 1130 1120 00 300 000000	96,967.00	8,079.72	0.00	0.00	20,760.78	76,206.22	78.59
Education Fund	10 E 1130 1120 00 300 000001	193,923.00	16,829.03	0.00	0.00	47,166.94	146,756.06	75.68
Education Fund	10 E 1130 1200 00 300 000000	0.00	0.00	0.00	0.00	0.00	0.00	0.00
Education Fund	10 E 1130 1200 00 300 000001	225,000.00	45,293.33	0.00	0.00	36,492.89	188,507.11	83.78
Education Fund	10 E 1130 1200 00 300 000002	15,250.00	0.00	0.00	0.00	12,254.98	2,995.02	19.64
Education Fund	10 E 1130 1200 00 300 000003	9,515.00	0.00	0.00	0.00	1,893.10	7,621.90	80.10
Education Fund	10 E 1130 1200 00 300 000004	139,076.00	0.00	0.00	0.00	-0.09	139,076.09	100.00
Education Fund	10 E 1130 1200 00 300 000005	13,000.00	0.00	0.00	0.00	12,594.11	405.89	3.12
Education Fund	10 E 1130 1300 00 300 000000	4,000.00	0.00	0.00	0.00	4,000.00	0.00	0.00
Education Fund	10 E 1130 2110 00 000 000000	12,242.00	0.00	0.00	0.00	12,242.00	0.00	0.00
Education Fund	10 E 1130 2110 00 300 000000	69,369.62	1,020.22	0.00	0.00	61,666.69	7,702.93	11.10
Education Fund	10 E 1130 2110 00 300 000001	22,096.00	6,951.62	0.00	0.00	-14,941.90	37,037.90	167.62
Education Fund	10 E 1130 2110 00 300 000002	1,920.00	0.00	0.00	0.00	531.80	1,388.20	72.30
Education Fund	10 E 1130 2110 00 300 000003	0.00	0.00	0.00	0.00	-518.24	518.24	0.00
Education Fund	10 E 1130 2110 00 300 000005	0.00	0.00	0.00	0.00	-12,768.55	12,768.55	0.00
Education Fund	10 E 1130 2110 01 300 000000	0.00	0.00	0.00	0.00	0.00	0.00	0.00
Education Fund	10 E 1130 2110 02 300 000000	22,792.00	1,899.34	0.00	0.00	7,849.10	14,942.90	65.56
Education Fund	10 E 1130 2110 05 300 000000	192,604.00	16,106.46	0.00	0.00	67,017.72	125,586.28	65.20

Expenditure Report

Fiscal Year: 2020-2021
Month: March

COUNTY OF GRUNDY SCHOOL DIST 111

Fund Description	Account Number	Revised Budget	MTD Activity	Encumbrance	Pending Activity	Available Funds	Year to Date Activity	Percent of Budget Used
Education Fund	10 E 1130 2110 06 300 000000	96,160.00	8,026.03	0.00	0.00	33,504.10	62,655.90	65.16
Education Fund	10 E 1130 2110 11 300 000000	178,512.00	14,876.04	0.00	0.00	62,045.66	116,466.34	65.24
Education Fund	10 E 1130 2110 12 300 000000	35,583.00	2,979.76	0.00	0.00	12,237.36	23,345.64	65.61
Education Fund	10 E 1130 2110 13 300 000000	169,831.00	14,171.47	0.00	0.00	58,239.73	111,591.27	65.71
Education Fund	10 E 1130 2110 15 300 000000	159,020.00	13,270.64	0.00	0.00	54,940.49	104,079.51	65.45
Education Fund	10 E 1130 2110 21 300 000000	0.00	0.00	0.00	0.00	0.00	0.00	0.00
Education Fund	10 E 1130 2110 27 300 000000	84,977.00	7,081.46	0.00	0.00	27,846.83	57,130.17	67.23
Education Fund	10 E 1130 2110 50 300 000000	140,090.00	11,677.34	0.00	0.00	48,423.43	91,666.57	65.43
Education Fund	10 E 1130 2210 27 300 000000	0.00	0.00	0.00	0.00	0.00	0.00	0.00
Education Fund	10 E 1130 2220 00 000 000000	0.00	340,868.83	0.00	314,561.64	-2,525,935.97	2,211,374.33	0.00
Education Fund	10 E 1130 2220 00 300 000000	74,176.39	0.00	0.00	0.00	74,176.39	0.00	0.00
Education Fund	10 E 1130 2220 00 300 000001	0.00	175.62	0.00	0.00	-2,046.99	2,046.99	0.00
Education Fund	10 E 1130 2220 01 300 000000	0.00	0.00	0.00	0.00	0.00	0.00	0.00
Education Fund	10 E 1130 2220 02 300 000000	41,446.57	3,745.50	0.00	-4.52	9,126.98	32,324.11	23777.99
Education Fund	10 E 1130 2220 05 300 000000	313,247.25	24,667.79	0.00	-61.07	65,877.97	247,430.35	78.99
Education Fund	10 E 1130 2220 06 300 000000	167,399.54	18,261.30	0.00	-43.72	9,797.53	157,645.73	94.17
Education Fund	10 E 1130 2220 11 300 000000	306,056.62	28,426.26	0.00	-71.72	56,148.84	249,979.50	81.68
Education Fund	10 E 1130 2220 12 300 000000	49,101.22	4,682.30	0.00	-11.72	8,596.17	40,516.77	82.52
Education Fund	10 E 1130 2220 13 300 000000	276,268.64	30,577.12	0.00	-72.52	70,716.93	205,624.23	74.43
Education Fund	10 E 1130 2220 15 300 000000	219,457.67	20,149.16	0.00	-64.52	41,791.94	177,730.25	80.99
Education Fund	10 E 1130 2220 21 300 000000	0.00	0.00	0.00	0.00	-727.49	727.49	0.00
Education Fund	10 E 1130 2220 25 300 000000	0.00	0.00	0.00	0.00	0.00	0.00	0.00
Education Fund	10 E 1130 2220 27 300 000000	140,202.33	15,242.42	0.00	-49.00	22,357.83	117,893.50	84.09
Education Fund	10 E 1130 2220 50 300 000000	193,226.37	21,821.34	0.00	-68.52	25,252.78	168,042.11	86.97
Education Fund	10 E 1130 2230 00 000 000000	0.00	10,466.51	0.00	16,612.94	-145,451.92	128,838.98	0.00
Education Fund	10 E 1130 2230 02 300 000000	0.00	73.60	0.00	0.00	-220.80	220.80	0.00
Education Fund	10 E 1130 2230 05 300 000000	0.00	685.40	0.00	0.00	-2,056.20	2,056.20	0.00
Education Fund	10 E 1130 2230 06 300 000000	0.00	397.44	0.00	0.00	-1,192.32	1,192.32	0.00
Education Fund	10 E 1130 2230 11 300 000000	0.00	625.60	0.00	0.00	-1,876.80	1,876.80	0.00
Education Fund	10 E 1130 2230 12 300 000000	0.00	110.40	0.00	0.00	-331.20	331.20	0.00
Education Fund	10 E 1130 2230 13 300 000000	0.00	699.20	0.00	0.00	-1,950.40	1,950.40	0.00
Education Fund	10 E 1130 2230 15 300 000000	0.00	529.00	0.00	0.00	-1,587.00	1,587.00	0.00
Education Fund	10 E 1130 2230 27 300 000000	0.00	660.50	0.00	0.00	-1,981.50	1,981.50	0.00

Expenditure Report

Fiscal Year: 2020-2021
Month: March

COUNTY OF GRUNDY SCHOOL DIST 111

Fund Description	Account Number	Revised Budget	MTD Activity	Encumbrance	Pending Activity	Available Funds	Year to Date Activity	Percent of Budget Used
Education Fund	10 E 1130 2230 50 300 000000	0.00	441.60	0.00	0.00	-1,324.80	1,324.80	0.00
Education Fund	10 E 1130 2300 00 300 000000	70,000.00	2,095.00	0.00	1,665.00	36,881.88	31,453.12	44.93
Education Fund	10 E 1130 3000 06 300 000000	800.00	0.00	0.00	0.00	800.00	0.00	0.00
Education Fund	10 E 1130 3000 06 302 000000	0.00	0.00	0.00	0.00	0.00	0.00	0.00
Education Fund	10 E 1130 3000 12 300 000000	8,500.00	0.00	1,500.00	0.00	7,000.00	0.00	0.00
Education Fund	10 E 1130 3000 12 300 000001	10,000.00	672.00	699.00	0.00	5,859.35	3,441.65	34.42
Education Fund	10 E 1130 3000 12 300 000002	0.00	0.00	0.00	0.00	0.00	0.00	0.00
Education Fund	10 E 1130 3000 12 302 000000	0.00	0.00	0.00	0.00	0.00	0.00	0.00
Education Fund	10 E 1130 3000 12 302 000001	0.00	0.00	0.00	0.00	0.00	0.00	0.00
Education Fund	10 E 1130 3000 12 302 000002	0.00	0.00	0.00	0.00	0.00	0.00	0.00
Education Fund	10 E 1130 3000 21 300 000000	0.00	0.00	0.00	0.00	0.00	0.00	0.00
Education Fund	10 E 1130 3100 25 300 000000	0.00	0.00	0.00	0.00	0.00	0.00	0.00
Education Fund	10 E 1130 3100 25 300 000001	0.00	0.00	0.00	0.00	0.00	0.00	0.00
Education Fund	10 E 1130 3140 00 300 000000	0.00	0.00	0.00	0.00	0.00	0.00	0.00
Education Fund	10 E 1130 3140 00 300 000001	0.00	0.00	0.00	0.00	0.00	0.00	238 0.00
Education Fund	10 E 1130 3220 00 300 000000	0.00	0.00	0.00	0.00	0.00	0.00	0.00
Education Fund	10 E 1130 3230 02 300 000000	0.00	0.00	0.00	0.00	0.00	0.00	0.00
Education Fund	10 E 1130 3230 02 302 000000	0.00	0.00	0.00	0.00	0.00	0.00	0.00
Education Fund	10 E 1130 3230 05 300 000000	350.00	0.00	0.00	0.00	350.00	0.00	0.00
Education Fund	10 E 1130 3230 05 302 000000	0.00	0.00	0.00	0.00	0.00	0.00	0.00
Education Fund	10 E 1130 3230 12 300 000000	4,600.00	375.00	0.00	0.00	1,959.00	2,641.00	57.41
Education Fund	10 E 1130 3230 12 300 000001	2,200.00	0.00	215.00	0.00	1,730.00	255.00	11.59
Education Fund	10 E 1130 3230 12 300 000002	0.00	0.00	0.00	0.00	0.00	0.00	0.00
Education Fund	10 E 1130 3230 12 302 000000	0.00	0.00	0.00	0.00	0.00	0.00	0.00
Education Fund	10 E 1130 3230 12 302 000001	0.00	0.00	0.00	0.00	0.00	0.00	0.00
Education Fund	10 E 1130 3230 12 302 000002	0.00	0.00	0.00	0.00	0.00	0.00	0.00
Education Fund	10 E 1130 3230 13 300 000000	3,000.00	0.00	0.00	0.00	3,000.00	0.00	0.00
Education Fund	10 E 1130 3230 13 302 000000	0.00	0.00	0.00	0.00	0.00	0.00	0.00
Education Fund	10 E 1130 3230 15 300 000000	0.00	0.00	0.00	0.00	0.00	0.00	0.00
Education Fund	10 E 1130 3230 15 302 000000	0.00	0.00	0.00	0.00	0.00	0.00	0.00
Education Fund	10 E 1130 3230 50 300 000000	10,000.00	0.00	0.00	0.00	9,310.00	690.00	6.90
Education Fund	10 E 1130 3230 50 300 000001	0.00	0.00	0.00	0.00	0.00	0.00	0.00
Education Fund	10 E 1130 3230 50 302 000000	0.00	0.00	0.00	0.00	0.00	0.00	0.00

Expenditure Report

Fiscal Year: 2020-2021
Month: March

COUNTY OF GRUNDY SCHOOL DIST 111

Fund Description	Account Number	Revised Budget	MTD Activity	Encumbrance	Pending Activity	Available Funds	Year to Date Activity	Percent of Budget Used
Education Fund	10 E 1130 3320 00 300 000000	1,000.00	0.00	0.00	0.00	1,000.00	0.00	0.00
Education Fund	10 E 1130 3320 00 300 000001	0.00	0.00	0.00	0.00	0.00	0.00	0.00
Education Fund	10 E 1130 3800 00 300 000000	0.00	0.00	0.00	0.00	-5,979.00	5,979.00	0.00
Education Fund	10 E 1130 3800 00 300 000001	0.00	0.00	0.00	0.00	0.00	0.00	0.00
Education Fund	10 E 1130 3800 21 300 000000	0.00	0.00	0.00	0.00	0.00	0.00	0.00
Education Fund	10 E 1130 4000 00 300 000000	0.00	0.00	0.00	0.00	0.00	0.00	0.00
Education Fund	10 E 1130 4000 05 300 000000	0.00	0.00	0.00	0.00	0.00	0.00	0.00
Education Fund	10 E 1130 4000 11 300 000000	0.00	0.00	0.00	0.00	0.00	0.00	0.00
Education Fund	10 E 1130 4000 50 300 000000	8,150.00	0.00	3,035.00	0.00	1,115.00	4,000.00	49.08
Education Fund	10 E 1130 4000 50 302 000000	0.00	0.00	0.00	0.00	0.00	0.00	0.00
Education Fund	10 E 1130 4100 00 300 000000	20,000.00	0.00	0.00	0.00	7,726.95	12,273.05	61.37
Education Fund	10 E 1130 4100 00 300 000001	0.00	0.00	0.00	0.00	0.00	0.00	0.00
Education Fund	10 E 1130 4100 00 300 000002	0.00	0.00	0.00	0.00	0.00	0.00	0.00
Education Fund	10 E 1130 4100 00 300 000003	0.00	0.00	0.00	0.00	0.00	0.00	0.00
Education Fund	10 E 1130 4100 00 300 000004	0.00	0.00	0.00	0.00	0.00	0.00	0.00
Education Fund	10 E 1130 4100 00 302 000000	0.00	0.00	0.00	0.00	0.00	0.00	0.00
Education Fund	10 E 1130 4100 02 300 000000	15,000.00	168.62	0.00	110.54	5,953.07	8,936.39	59.58
Education Fund	10 E 1130 4100 02 300 000001	3,150.00	0.00	0.00	0.00	230.00	2,920.00	92.70
Education Fund	10 E 1130 4100 02 302 000000	0.00	0.00	0.00	0.00	0.00	0.00	0.00
Education Fund	10 E 1130 4100 02 302 000001	0.00	0.00	0.00	0.00	0.00	0.00	0.00
Education Fund	10 E 1130 4100 05 300 000000	1,744.00	43.92	1,649.97	0.00	50.11	43.92	2.52
Education Fund	10 E 1130 4100 05 300 000001	0.00	0.00	0.00	0.00	0.00	0.00	0.00
Education Fund	10 E 1130 4100 05 302 000000	0.00	0.00	0.00	0.00	0.00	0.00	0.00
Education Fund	10 E 1130 4100 05 302 000001	0.00	0.00	0.00	0.00	0.00	0.00	0.00
Education Fund	10 E 1130 4100 06 300 000000	4,000.00	0.00	0.00	0.00	1,635.97	2,364.03	59.10
Education Fund	10 E 1130 4100 06 300 000001	0.00	0.00	0.00	0.00	0.00	0.00	0.00
Education Fund	10 E 1130 4100 06 302 000000	0.00	0.00	0.00	0.00	0.00	0.00	0.00
Education Fund	10 E 1130 4100 06 302 000001	0.00	0.00	0.00	0.00	0.00	0.00	0.00
Education Fund	10 E 1130 4100 11 300 000000	2,200.00	0.00	632.02	0.00	1,505.84	62.14	2.82
Education Fund	10 E 1130 4100 11 300 000001	0.00	0.00	0.00	0.00	0.00	0.00	0.00
Education Fund	10 E 1130 4100 11 302 000000	0.00	0.00	0.00	0.00	0.00	0.00	0.00
Education Fund	10 E 1130 4100 11 302 000001	0.00	0.00	0.00	0.00	0.00	0.00	0.00
Education Fund	10 E 1130 4100 12 300 000000	3,500.00	419.13	0.00	0.00	1,093.13	2,406.87	68.77

239

Expenditure Report

Fiscal Year: 2020-2021
Month: March

COUNTY OF GRUNDY SCHOOL DIST 111

Fund Description	Account Number	Revised Budget	MTD Activity	Encumbrance	Pending Activity	Available Funds	Year to Date Activity	Percent of Budget Used
Education Fund	10 E 1130 4100 12 300 000001	3,500.00	0.00	994.49	0.00	886.38	1,619.13	46.26
Education Fund	10 E 1130 4100 12 300 000002	1,000.00	0.00	0.00	0.00	933.58	66.42	6.64
Education Fund	10 E 1130 4100 12 300 000003	0.00	0.00	0.00	0.00	0.00	0.00	0.00
Education Fund	10 E 1130 4100 12 302 000000	0.00	0.00	0.00	0.00	0.00	0.00	0.00
Education Fund	10 E 1130 4100 12 302 000001	8,590.00	0.00	0.00	0.00	1,026.25	7,563.75	88.05
Education Fund	10 E 1130 4100 12 302 000002	0.00	0.00	11.90	0.00	-69.98	58.08	0.00
Education Fund	10 E 1130 4100 12 302 000003	0.00	0.00	0.00	0.00	0.00	0.00	0.00
Education Fund	10 E 1130 4100 13 300 000000	23,000.00	466.98	2,902.10	66.95	14,794.39	5,236.56	22.77
Education Fund	10 E 1130 4100 13 300 000001	0.00	0.00	0.00	0.00	-120.00	120.00	0.00
Education Fund	10 E 1130 4100 13 302 000000	0.00	0.00	0.00	0.00	0.00	0.00	0.00
Education Fund	10 E 1130 4100 13 302 000001	0.00	0.00	0.00	0.00	0.00	0.00	0.00
Education Fund	10 E 1130 4100 15 300 000000	5,000.00	509.30	224.48	-61.97	4,004.99	832.50	16.65
Education Fund	10 E 1130 4100 15 300 000001	0.00	0.00	0.00	0.00	0.00	0.00	0.00
Education Fund	10 E 1130 4100 15 302 000000	0.00	0.00	0.00	0.00	0.00	0.00	0.00
Education Fund	10 E 1130 4100 15 302 000001	0.00	0.00	0.00	0.00	0.00	0.00	240 0.00
Education Fund	10 E 1130 4100 21 300 000000	0.00	0.00	0.00	0.00	0.00	0.00	0.00
Education Fund	10 E 1130 4100 50 300 000000	30,000.00	-207.72	11,536.29	231.05	9,961.63	8,271.03	27.57
Education Fund	10 E 1130 4100 50 300 000001	500.00	0.00	0.00	0.00	500.00	0.00	0.00
Education Fund	10 E 1130 4100 50 302 000000	0.00	0.00	0.00	0.00	0.00	0.00	0.00
Education Fund	10 E 1130 4100 50 302 000001	0.00	0.00	0.00	0.00	0.00	0.00	0.00
Education Fund	10 E 1130 4200 00 300 000000	0.00	0.00	12,213.99	0.00	-12,213.99	0.00	0.00
Education Fund	10 E 1130 4200 00 302 000000	0.00	0.00	0.00	0.00	0.00	0.00	0.00
Education Fund	10 E 1130 4200 02 300 000000	0.00	0.00	0.00	0.00	0.00	0.00	0.00
Education Fund	10 E 1130 4200 02 302 000000	0.00	0.00	0.00	0.00	0.00	0.00	0.00
Education Fund	10 E 1130 4200 05 300 000000	10,500.00	0.00	206.36	-369.75	4,552.77	6,110.62	58.20
Education Fund	10 E 1130 4200 05 302 000000	0.00	0.00	0.00	0.00	-509.70	509.70	0.00
Education Fund	10 E 1130 4200 06 300 000000	11,104.00	0.00	0.00	0.00	-1,019.42	12,123.42	109.18
Education Fund	10 E 1130 4200 06 302 000000	0.00	0.00	0.00	0.00	0.00	0.00	0.00
Education Fund	10 E 1130 4200 11 300 000000	135,000.00	0.00	0.00	0.00	124,863.60	10,136.40	7.51
Education Fund	10 E 1130 4200 11 302 000000	0.00	0.00	0.00	0.00	0.00	0.00	0.00
Education Fund	10 E 1130 4200 12 300 000000	0.00	0.00	0.00	0.00	0.00	0.00	0.00
Education Fund	10 E 1130 4200 12 300 000001	1,200.00	0.00	0.00	0.00	854.20	345.80	28.82
Education Fund	10 E 1130 4200 12 300 000002	0.00	0.00	0.00	0.00	0.00	0.00	0.00

Expenditure Report

Fiscal Year: 2020-2021
Month: March

COUNTY OF GRUNDY SCHOOL DIST 111

Fund Description	Account Number	Revised Budget	MTD Activity	Encumbrance	Pending Activity	Available Funds	Year to Date Activity	Percent of Budget Used
Education Fund	10 E 1130 4200 12 302 000000	0.00	0.00	0.00	0.00	0.00	0.00	0.00
Education Fund	10 E 1130 4200 12 302 000001	0.00	0.00	0.00	0.00	0.00	0.00	0.00
Education Fund	10 E 1130 4200 12 302 000002	0.00	0.00	0.00	0.00	0.00	0.00	0.00
Education Fund	10 E 1130 4200 13 300 000000	12,000.00	0.00	0.00	0.00	719.70	11,280.30	94.00
Education Fund	10 E 1130 4200 13 302 000000	0.00	0.00	0.00	0.00	0.00	0.00	0.00
Education Fund	10 E 1130 4200 15 300 000000	14,900.00	428.60	1,197.27	-12.18	12,388.02	1,326.89	8.91
Education Fund	10 E 1130 4200 15 302 000000	0.00	0.00	0.00	0.00	0.00	0.00	0.00
Education Fund	10 E 1130 4200 21 300 000000	0.00	0.00	0.00	0.00	0.00	0.00	0.00
Education Fund	10 E 1130 4200 50 300 000000	0.00	0.00	0.00	0.00	0.00	0.00	0.00
Education Fund	10 E 1130 4200 50 302 000000	0.00	0.00	0.00	0.00	0.00	0.00	0.00
Education Fund	10 E 1130 4400 02 300 000000	0.00	0.00	0.00	0.00	0.00	0.00	0.00
Education Fund	10 E 1130 4400 02 302 000000	0.00	0.00	0.00	0.00	0.00	0.00	0.00
Education Fund	10 E 1130 4400 05 300 000000	700.00	0.00	0.00	0.00	700.00	0.00	0.00
Education Fund	10 E 1130 4400 05 302 000000	0.00	0.00	0.00	0.00	0.00	0.00	241 0.00
Education Fund	10 E 1130 4400 15 300 000000	0.00	0.00	0.00	0.00	0.00	0.00	0.00
Education Fund	10 E 1130 4400 15 302 000000	0.00	0.00	0.00	0.00	0.00	0.00	0.00
Education Fund	10 E 1130 4400 50 300 000000	0.00	0.00	0.00	0.00	0.00	0.00	0.00
Education Fund	10 E 1130 4400 50 302 000000	0.00	0.00	0.00	0.00	0.00	0.00	0.00
Education Fund	10 E 1130 4700 02 300 000000	0.00	0.00	0.00	0.00	0.00	0.00	0.00
Education Fund	10 E 1130 4700 02 302 000000	0.00	0.00	0.00	0.00	0.00	0.00	0.00
Education Fund	10 E 1130 4700 05 300 000000	0.00	0.00	0.00	0.00	0.00	0.00	0.00
Education Fund	10 E 1130 4700 05 302 000000	0.00	0.00	0.00	0.00	0.00	0.00	0.00
Education Fund	10 E 1130 4700 06 300 000000	0.00	0.00	0.00	0.00	0.00	0.00	0.00
Education Fund	10 E 1130 4700 06 302 000000	0.00	0.00	0.00	0.00	0.00	0.00	0.00
Education Fund	10 E 1130 4700 11 300 000000	0.00	0.00	0.00	0.00	0.00	0.00	0.00
Education Fund	10 E 1130 4700 11 302 000000	0.00	0.00	0.00	0.00	0.00	0.00	0.00
Education Fund	10 E 1130 4700 12 300 000000	0.00	0.00	0.00	0.00	0.00	0.00	0.00
Education Fund	10 E 1130 4700 12 300 000001	0.00	0.00	0.00	0.00	0.00	0.00	0.00
Education Fund	10 E 1130 4700 12 300 000002	0.00	0.00	0.00	0.00	0.00	0.00	0.00
Education Fund	10 E 1130 4700 12 302 000000	0.00	0.00	7,034.80	0.00	-7,034.80	0.00	0.00
Education Fund	10 E 1130 4700 12 302 000001	0.00	0.00	0.00	0.00	0.00	0.00	0.00
Education Fund	10 E 1130 4700 12 302 000002	0.00	0.00	0.00	0.00	0.00	0.00	0.00
Education Fund	10 E 1130 4700 13 300 000000	6,700.00	0.00	0.00	0.00	50.00	6,650.00	99.25

Expenditure Report

Fiscal Year: 2020-2021
Month: March

COUNTY OF GRUNDY SCHOOL DIST 111

Fund Description	Account Number	Revised Budget	MTD Activity	Encumbrance	Pending Activity	Available Funds	Year to Date Activity	Percent of Budget Used
Education Fund	10 E 1130 4700 13 302 000000	0.00	0.00	0.00	0.00	0.00	0.00	0.00
Education Fund	10 E 1130 4700 15 300 000000	0.00	0.00	0.00	0.00	0.00	0.00	0.00
Education Fund	10 E 1130 4700 15 302 000000	0.00	0.00	0.00	0.00	0.00	0.00	0.00
Education Fund	10 E 1130 4700 21 300 000000	0.00	0.00	0.00	0.00	0.00	0.00	0.00
Education Fund	10 E 1130 4700 50 300 000000	0.00	0.00	0.00	0.00	0.00	0.00	0.00
Education Fund	10 E 1130 4700 50 302 000000	0.00	0.00	0.00	0.00	0.00	0.00	0.00
Education Fund	10 E 1130 5400 02 300 000000	0.00	0.00	0.00	0.00	0.00	0.00	0.00
Education Fund	10 E 1130 5400 02 302 000000	0.00	0.00	0.00	0.00	0.00	0.00	0.00
Education Fund	10 E 1130 5400 05 300 000000	0.00	0.00	0.00	0.00	0.00	0.00	0.00
Education Fund	10 E 1130 5400 05 302 000000	0.00	0.00	0.00	0.00	0.00	0.00	0.00
Education Fund	10 E 1130 5400 06 300 000000	0.00	0.00	0.00	0.00	0.00	0.00	0.00
Education Fund	10 E 1130 5400 06 302 000000	0.00	0.00	0.00	0.00	0.00	0.00	0.00
Education Fund	10 E 1130 5400 11 300 000000	0.00	0.00	0.00	0.00	0.00	0.00	0.00
Education Fund	10 E 1130 5400 11 302 000000	0.00	0.00	0.00	0.00	0.00	0.00	0.00
Education Fund	10 E 1130 5400 12 300 000000	21,000.00	0.00	0.00	259.00	8,111.11	12,629.89	60.14
Education Fund	10 E 1130 5400 12 300 000001	2,900.00	0.00	0.00	0.00	2,900.00	0.00	0.00
Education Fund	10 E 1130 5400 12 300 000002	0.00	0.00	0.00	0.00	0.00	0.00	0.00
Education Fund	10 E 1130 5400 12 302 000000	0.00	0.00	0.00	0.00	0.00	0.00	0.00
Education Fund	10 E 1130 5400 12 302 000001	0.00	0.00	0.00	0.00	0.00	0.00	0.00
Education Fund	10 E 1130 5400 12 302 000002	0.00	0.00	0.00	0.00	0.00	0.00	0.00
Education Fund	10 E 1130 5400 13 300 000000	0.00	0.00	0.00	0.00	0.00	0.00	0.00
Education Fund	10 E 1130 5400 13 302 000000	0.00	0.00	0.00	0.00	0.00	0.00	0.00
Education Fund	10 E 1130 5400 15 300 000000	0.00	0.00	0.00	0.00	0.00	0.00	0.00
Education Fund	10 E 1130 5400 15 302 000000	0.00	0.00	0.00	0.00	0.00	0.00	0.00
Education Fund	10 E 1130 5400 21 300 000000	0.00	0.00	0.00	0.00	0.00	0.00	0.00
Education Fund	10 E 1130 5400 50 300 000000	0.00	0.00	0.00	0.00	0.00	0.00	0.00
Education Fund	10 E 1130 5400 50 302 000000	0.00	0.00	0.00	0.00	0.00	0.00	0.00
Education Fund	10 E 1130 5600 21 300 000000	0.00	0.00	0.00	0.00	0.00	0.00	0.00
Education Fund	10 E 1130 6400 00 300 000000	0.00	0.00	0.00	0.00	0.00	0.00	0.00
Education Fund	10 E 1130 6400 02 300 000000	0.00	0.00	0.00	0.00	0.00	0.00	0.00
Education Fund	10 E 1130 6400 02 300 000000	0.00	0.00	0.00	0.00	0.00	0.00	0.00
Education Fund	10 E 1130 6400 05 300 000000	0.00	0.00	0.00	-5.00	-144.89	149.89	0.00
Education Fund	10 E 1130 6400 05 302 000000	0.00	0.00	0.00	0.00	0.00	0.00	0.00
Education Fund	10 E 1130 6400 06 300 000000	0.00	0.00	0.00	0.00	0.00	0.00	0.00

Expenditure Report

Fiscal Year: 2020-2021
Month: March

COUNTY OF GRUNDY SCHOOL DIST 111

Fund Description	Account Number	Revised Budget	MTD Activity	Encumbrance	Pending Activity	Available Funds	Year to Date Activity	Percent of Budget Used
Education Fund	10 E 1130 6400 06 302 000000	0.00	0.00	0.00	0.00	0.00	0.00	0.00
Education Fund	10 E 1130 6400 11 300 000000	0.00	0.00	0.00	0.00	0.00	0.00	0.00
Education Fund	10 E 1130 6400 11 302 000000	0.00	0.00	0.00	0.00	0.00	0.00	0.00
Education Fund	10 E 1130 6400 12 300 000000	1,500.00	0.00	0.00	0.00	1,500.00	0.00	0.00
Education Fund	10 E 1130 6400 12 300 000001	750.00	0.00	0.00	0.00	750.00	0.00	0.00
Education Fund	10 E 1130 6400 12 300 000002	0.00	0.00	0.00	0.00	0.00	0.00	0.00
Education Fund	10 E 1130 6400 12 300 000003	5,485.00	625.00	1,640.00	0.00	3,395.00	450.00	8.20
Education Fund	10 E 1130 6400 12 300 000004	1,500.00	60.00	0.00	0.00	815.00	685.00	45.67
Education Fund	10 E 1130 6400 12 300 000005	2,100.00	0.00	0.00	0.00	2,100.00	0.00	0.00
Education Fund	10 E 1130 6400 12 302 000000	0.00	0.00	0.00	0.00	0.00	0.00	0.00
Education Fund	10 E 1130 6400 12 302 000001	0.00	0.00	0.00	0.00	0.00	0.00	0.00
Education Fund	10 E 1130 6400 12 302 000002	0.00	0.00	0.00	0.00	0.00	0.00	0.00
Education Fund	10 E 1130 6400 12 302 000003	0.00	0.00	0.00	0.00	0.00	0.00	0.00
Education Fund	10 E 1130 6400 12 302 000004	0.00	0.00	0.00	0.00	0.00	0.00	0.00
Education Fund	10 E 1130 6400 12 302 000005	0.00	0.00	0.00	0.00	0.00	0.00	0.00
Education Fund	10 E 1130 6400 13 300 000000	750.00	0.00	0.00	0.00	750.00	0.00	0.00
Education Fund	10 E 1130 6400 13 300 000001	0.00	0.00	0.00	0.00	0.00	0.00	0.00
Education Fund	10 E 1130 6400 13 302 000000	0.00	0.00	0.00	0.00	0.00	0.00	0.00
Education Fund	10 E 1130 6400 15 300 000000	0.00	0.00	0.00	0.00	0.00	0.00	0.00
Education Fund	10 E 1130 6400 15 302 000000	0.00	0.00	0.00	0.00	0.00	0.00	0.00
Education Fund	10 E 1130 6400 21 300 000000	0.00	0.00	0.00	0.00	0.00	0.00	0.00
Education Fund	10 E 1130 6400 50 300 000000	0.00	0.00	0.00	0.00	0.00	0.00	0.00
Education Fund	10 E 1130 6400 50 302 000000	0.00	0.00	0.00	0.00	0.00	0.00	0.00
Education Fund	10 E 1130 6700 00 300 000000	0.00	0.00	0.00	0.00	0.00	0.00	0.00
Education Fund	10 E 1130 6900 00 300 000000	5,000.00	0.00	0.00	0.00	5,000.00	0.00	0.00
Education Fund	10 E 1200 1100 00 300 000000	1,116,819.00	93,276.42	0.00	0.00	289,650.71	827,168.29	74.06
Education Fund	10 E 1200 1100 00 300 000001	80,000.00	0.00	0.00	0.00	80,000.00	0.00	0.00
Education Fund	10 E 1200 1100 00 300 000002	114,216.00	9,518.00	0.00	0.00	30,430.80	83,785.20	73.36
Education Fund	10 E 1200 1100 00 300 000003	36,114.00	3,009.50	0.00	0.00	9,028.50	27,085.50	75.00
Education Fund	10 E 1200 1100 00 300 000004	0.00	0.00	0.00	0.00	0.00	0.00	0.00
Education Fund	10 E 1200 2110 00 300 000000	141,014.00	11,777.51	0.00	0.00	48,906.53	92,107.47	65.32
Education Fund	10 E 1200 2220 00 300 000000	283,025.90	24,780.22	0.00	-72.52	67,698.60	215,399.82	76.11
Education Fund	10 E 1200 2220 00 300 000001	0.00	0.00	0.00	0.00	0.00	0.00	0.00

243

Expenditure Report

Fiscal Year: 2020-2021
Month: March

COUNTY OF GRUNDY SCHOOL DIST 111

Fund Description	Account Number	Revised Budget	MTD Activity	Encumbrance	Pending Activity	Available Funds	Year to Date Activity	Percent of Budget Used
Education Fund	10 E 1200 2220 00 300 000002	0.00	733.62	0.00	0.00	-6,250.50	6,250.50	0.00
Education Fund	10 E 1200 2220 00 300 000003	0.00	710.00	0.00	0.00	-5,977.20	5,977.20	0.00
Education Fund	10 E 1200 2220 00 302 000000	0.00	0.00	0.00	-0.52	-274.10	274.62	0.00
Education Fund	10 E 1200 2230 00 300 000000	0.00	662.40	0.00	0.00	-1,987.20	1,987.20	0.00
Education Fund	10 E 1200 2230 00 300 000003	0.00	36.80	0.00	0.00	-110.40	110.40	0.00
Education Fund	10 E 1200 3000 00 300 000000	27,000.00	0.00	0.00	52.99	23,475.24	3,471.77	12.86
Education Fund	10 E 1200 3000 00 300 000001	6,300.00	0.00	0.00	0.00	3,250.47	3,049.53	48.41
Education Fund	10 E 1200 3000 00 300 000002	0.00	0.00	0.00	0.00	0.00	0.00	0.00
Education Fund	10 E 1200 3000 00 300 000003	184,853.00	0.00	0.00	0.00	184,853.00	0.00	0.00
Education Fund	10 E 1200 4100 00 300 000000	3,500.00	0.00	0.00	0.00	3,305.67	194.33	5.55
Education Fund	10 E 1200 4100 00 300 000001	2,600.00	0.00	0.00	0.00	2,600.00	0.00	0.00
Education Fund	10 E 1200 4100 00 300 000002	2,713.00	141.46	0.00	74.79	1,959.55	678.66	25.02
Education Fund	10 E 1200 4200 00 300 000000	150.00	0.00	0.00	0.00	150.00	0.00	0.00
Education Fund	10 E 1200 4700 00 300 000000	0.00	0.00	0.00	0.00	0.00	0.00	0.00
Education Fund	10 E 1200 5000 00 300 000000	9,500.00	0.00	0.00	0.00	8,034.11	1,465.89	15.43
Education Fund	10 E 1200 6400 00 000 000000	1,800.00	0.00	0.00	0.00	1,800.00	0.00	0.00
Education Fund	10 E 1200 6400 00 300 000000	0.00	0.00	0.00	0.00	0.00	0.00	0.00
Education Fund	10 E 1200 6700 00 300 000000	0.00	0.00	0.00	0.00	0.00	0.00	0.00
Education Fund	10 E 1200 6700 00 300 000001	0.00	0.00	0.00	0.00	0.00	0.00	0.00
Education Fund	10 E 1200 6700 00 300 000002	0.00	8,660.71	0.00	0.00	-35,614.16	35,614.16	0.00
Education Fund	10 E 1250 2110 00 300 000000	0.00	0.00	0.00	0.00	0.00	0.00	0.00
Education Fund	10 E 1250 3000 00 300 000000	0.00	0.00	0.00	0.00	-13,875.00	13,875.00	0.00
Education Fund	10 E 1250 3000 00 300 000001	0.00	0.00	0.00	0.00	0.00	0.00	0.00
Education Fund	10 E 1250 6700 00 300 000000	0.00	0.00	0.00	0.00	0.00	0.00	0.00
Education Fund	10 E 1250 6700 00 300 000001	0.00	0.00	0.00	0.00	0.00	0.00	0.00
Education Fund	10 E 1250 6700 00 300 000002	0.00	0.00	0.00	0.00	0.00	0.00	0.00
Education Fund	10 E 1400 1100 00 300 000000	231,232.00	19,319.34	0.00	0.00	56,401.42	174,830.58	75.61
Education Fund	10 E 1400 1100 10 300 000000	174,125.00	14,535.42	0.00	0.00	50,705.41	123,419.59	70.88
Education Fund	10 E 1400 2110 00 300 000000	21,985.00	2,439.34	0.00	0.00	2,679.65	19,305.35	87.81
Education Fund	10 E 1400 2110 10 300 000000	28,190.00	1,835.30	0.00	0.00	13,996.76	14,193.24	50.35
Education Fund	10 E 1400 2110 11 300 000000	0.00	0.00	0.00	0.00	0.00	0.00	0.00
Education Fund	10 E 1400 2220 00 300 000000	51,275.47	4,520.20	0.00	0.00	12,979.28	38,296.19	74.69
Education Fund	10 E 1400 2220 10 300 000000	48,357.24	5,260.04	0.00	-8.52	3,056.81	45,308.95	93.70

244

Expenditure Report

Fiscal Year: 2020-2021
Month: March

COUNTY OF GRUNDY SCHOOL DIST 111

Fund Description	Account Number	Revised Budget	MTD Activity	Encumbrance	Pending Activity	Available Funds	Year to Date Activity	Percent of Budget Used
Education Fund	10 E 1400 2230 00 300 000000	0.00	110.40	0.00	0.00	-331.20	331.20	0.00
Education Fund	10 E 1400 2230 10 300 000000	0.00	110.40	0.00	0.00	-331.20	331.20	0.00
Education Fund	10 E 1400 3230 10 300 000000	25,000.00	129.83	0.00	0.00	24,870.17	129.83	0.52
Education Fund	10 E 1400 3230 10 302 000000	0.00	0.00	0.00	0.00	0.00	0.00	0.00
Education Fund	10 E 1400 4000 00 300 320000	0.00	0.00	0.00	0.00	0.00	0.00	0.00
Education Fund	10 E 1400 4100 00 300 000000	0.00	0.00	0.00	0.00	0.00	0.00	0.00
Education Fund	10 E 1400 4100 10 300 000000	0.00	0.00	0.00	0.00	0.00	0.00	0.00
Education Fund	10 E 1400 4100 10 300 000001	68,412.00	658.08	2,912.88	1,423.26	17,037.41	47,038.45	68.76
Education Fund	10 E 1400 4100 10 300 000002	0.00	0.00	0.00	0.00	0.00	0.00	0.00
Education Fund	10 E 1400 4100 10 302 000000	0.00	0.00	0.00	0.00	0.00	0.00	0.00
Education Fund	10 E 1400 4100 10 302 000001	0.00	0.00	0.00	0.00	0.00	0.00	0.00
Education Fund	10 E 1400 4200 10 300 000000	0.00	0.00	0.00	0.00	0.00	0.00	0.00
Education Fund	10 E 1400 4200 10 302 000000	0.00	0.00	0.00	0.00	0.00	0.00	0.00
Education Fund	10 E 1400 4700 10 300 000000	0.00	0.00	0.00	0.00	0.00	0.00	0.00
Education Fund	10 E 1400 4700 10 302 000000	0.00	0.00	0.00	0.00	0.00	0.00	245 0.00
Education Fund	10 E 1400 5400 10 300 000000	0.00	0.00	0.00	0.00	0.00	0.00	0.00
Education Fund	10 E 1400 5400 10 302 000000	0.00	0.00	0.00	0.00	0.00	0.00	0.00
Education Fund	10 E 1400 6400 10 300 000000	3,200.00	0.00	0.00	0.00	0.00	3,200.00	100.00
Education Fund	10 E 1400 6400 10 302 000000	0.00	0.00	0.00	0.00	0.00	0.00	0.00
Education Fund	10 E 1400 6700 00 300 000000	0.00	0.00	0.00	0.00	0.00	0.00	0.00
Education Fund	10 E 1401 1100 01 300 000000	214,851.00	18,630.56	0.00	0.00	48,265.16	166,585.84	77.54
Education Fund	10 E 1401 2110 01 300 000000	27,170.44	2,352.40	0.00	0.00	8,728.49	18,441.95	67.88
Education Fund	10 E 1401 2220 01 300 000000	31,788.60	2,963.70	0.00	-4.52	6,126.15	25,666.97	80.74
Education Fund	10 E 1401 2230 01 300 000000	0.00	73.60	0.00	0.00	-220.80	220.80	0.00
Education Fund	10 E 1401 3000 01 300 000000	1,500.00	0.00	0.00	0.00	1,500.00	0.00	0.00
Education Fund	10 E 1401 3000 01 302 000000	0.00	0.00	0.00	0.00	0.00	0.00	0.00
Education Fund	10 E 1401 3900 01 300 000000	0.00	0.00	0.00	0.00	0.00	0.00	0.00
Education Fund	10 E 1401 4000 01 300 000000	0.00	0.00	0.00	0.00	0.00	0.00	0.00
Education Fund	10 E 1401 4100 01 300 000000	17,000.00	629.21	7,500.00	677.23	3,171.92	5,650.85	33.24
Education Fund	10 E 1401 4100 01 300 000001	0.00	0.00	0.00	0.00	0.00	0.00	0.00
Education Fund	10 E 1401 4100 01 302 000000	0.00	0.00	0.00	0.00	0.00	0.00	0.00
Education Fund	10 E 1401 4100 01 302 000001	0.00	0.00	0.00	0.00	0.00	0.00	0.00
Education Fund	10 E 1401 4200 01 300 000000	0.00	0.00	0.00	0.00	0.00	0.00	0.00

Expenditure Report

Fiscal Year: 2020-2021
Month: March

COUNTY OF GRUNDY SCHOOL DIST 111

Fund Description	Account Number	Revised Budget	MTD Activity	Encumbrance	Pending Activity	Available Funds	Year to Date Activity	Percent of Budget Used
Education Fund	10 E 1401 4200 01 302 000000	0.00	0.00	0.00	0.00	0.00	0.00	0.00
Education Fund	10 E 1401 4400 01 300 000000	0.00	0.00	0.00	0.00	0.00	0.00	0.00
Education Fund	10 E 1401 4400 01 302 000000	0.00	0.00	0.00	0.00	0.00	0.00	0.00
Education Fund	10 E 1401 4700 01 300 000000	0.00	0.00	0.00	0.00	0.00	0.00	0.00
Education Fund	10 E 1401 4700 01 302 000000	0.00	0.00	0.00	0.00	0.00	0.00	0.00
Education Fund	10 E 1401 5000 01 300 000000	0.00	0.00	0.00	0.00	0.00	0.00	0.00
Education Fund	10 E 1401 5400 01 300 000000	23,352.00	0.00	0.00	0.00	23,352.00	0.00	0.00
Education Fund	10 E 1401 5400 01 302 000000	0.00	0.00	0.00	0.00	0.00	0.00	0.00
Education Fund	10 E 1401 6400 01 300 000000	3,850.00	0.00	0.00	0.00	3,850.00	0.00	0.00
Education Fund	10 E 1401 6400 01 302 000000	0.00	0.00	0.00	0.00	0.00	0.00	0.00
Education Fund	10 E 1407 1100 03 300 000000	211,175.00	17,647.94	0.00	0.00	48,968.50	162,206.50	76.81
Education Fund	10 E 1407 2110 03 300 000000	26,638.00	2,228.27	0.00	0.00	8,965.13	17,672.87	66.34
Education Fund	10 E 1407 2220 03 300 000000	65,256.96	4,545.36	0.00	-12.52	25,560.84	39,708.64	60.85
Education Fund	10 E 1407 2230 03 300 000000	0.00	108.28	0.00	0.00	-324.84	324.84	0.00
Education Fund	10 E 1407 3000 03 300 000000	0.00	0.00	0.00	0.00	3,000.00	-3,000.00	0.00
Education Fund	10 E 1407 3000 03 300 000001	0.00	0.00	0.00	0.00	0.00	0.00	0.00
Education Fund	10 E 1407 3230 03 300 000000	0.00	0.00	0.00	0.00	0.00	0.00	0.00
Education Fund	10 E 1407 3230 03 302 000000	0.00	0.00	0.00	0.00	0.00	0.00	0.00
Education Fund	10 E 1407 4100 03 300 000000	3,500.00	0.00	0.00	0.00	3,500.00	0.00	0.00
Education Fund	10 E 1407 4100 03 300 000001	0.00	0.00	0.00	0.00	0.00	0.00	0.00
Education Fund	10 E 1407 4100 03 302 000000	0.00	0.00	0.00	0.00	0.00	0.00	0.00
Education Fund	10 E 1407 4100 03 302 000001	0.00	0.00	0.00	0.00	0.00	0.00	0.00
Education Fund	10 E 1407 4200 03 300 000000	0.00	0.00	0.00	0.00	0.00	0.00	0.00
Education Fund	10 E 1407 4200 03 302 000000	0.00	0.00	0.00	0.00	0.00	0.00	0.00
Education Fund	10 E 1407 4400 03 300 000000	0.00	0.00	0.00	0.00	0.00	0.00	0.00
Education Fund	10 E 1407 4400 03 302 000000	0.00	0.00	0.00	0.00	0.00	0.00	0.00
Education Fund	10 E 1407 4700 03 300 000000	13,275.00	0.00	0.00	0.00	2,180.00	11,095.00	83.58
Education Fund	10 E 1407 4700 03 302 000000	0.00	0.00	0.00	0.00	0.00	0.00	0.00
Education Fund	10 E 1407 5400 03 300 000000	0.00	0.00	0.00	0.00	0.00	0.00	0.00
Education Fund	10 E 1407 5400 03 302 000000	0.00	0.00	0.00	0.00	0.00	0.00	0.00
Education Fund	10 E 1407 6400 03 300 000000	315.00	0.00	0.00	0.00	315.00	0.00	0.00
Education Fund	10 E 1407 6400 03 302 000000	0.00	0.00	0.00	0.00	0.00	0.00	0.00
Education Fund	10 E 1410 1100 00 300 000000	0.00	0.00	0.00	0.00	0.00	0.00	0.00

Expenditure Report

Fiscal Year: 2020-2021
Month: March

COUNTY OF GRUNDY SCHOOL DIST 111

Fund Description	Account Number	Revised Budget	MTD Activity	Encumbrance	Pending Activity	Available Funds	Year to Date Activity	Percent of Budget Used
Education Fund	10 E 1410 2110 00 300 000000	0.00	0.00	0.00	0.00	0.00	0.00	0.00
Education Fund	10 E 1410 2220 00 300 000000	565.00	0.00	0.00	-0.52	290.89	274.63	48.61
Education Fund	10 E 1410 3000 00 300 000000	0.00	0.00	0.00	0.00	0.00	0.00	0.00
Education Fund	10 E 1410 3000 00 302 000000	0.00	0.00	0.00	0.00	0.00	0.00	0.00
Education Fund	10 E 1410 4000 00 300 000000	0.00	0.00	0.00	0.00	0.00	0.00	0.00
Education Fund	10 E 1410 4100 00 300 000000	500.00	0.00	0.00	0.00	500.00	0.00	0.00
Education Fund	10 E 1410 4100 00 300 000001	0.00	0.00	0.00	0.00	0.00	0.00	0.00
Education Fund	10 E 1410 4100 00 302 000000	0.00	0.00	0.00	0.00	0.00	0.00	0.00
Education Fund	10 E 1410 4100 00 302 000001	0.00	0.00	0.00	0.00	0.00	0.00	0.00
Education Fund	10 E 1410 4400 00 300 000000	0.00	0.00	0.00	0.00	0.00	0.00	0.00
Education Fund	10 E 1410 4400 00 302 000000	0.00	0.00	0.00	0.00	0.00	0.00	0.00
Education Fund	10 E 1410 4700 00 300 000000	0.00	0.00	0.00	0.00	0.00	0.00	0.00
Education Fund	10 E 1410 4700 00 302 000000	0.00	0.00	0.00	0.00	0.00	0.00	0.00
Education Fund	10 E 1410 5400 00 300 000000	3,500.00	0.00	0.00	0.00	3,707.57	-207.57	247 -5.93
Education Fund	10 E 1410 5400 00 302 000000	0.00	0.00	0.00	0.00	0.00	0.00	0.00
Education Fund	10 E 1410 6400 00 300 000000	0.00	0.00	0.00	0.00	0.00	0.00	0.00
Education Fund	10 E 1410 6400 00 302 000000	0.00	0.00	0.00	0.00	0.00	0.00	0.00
Education Fund	10 E 1411 1100 00 300 000000	79,441.00	6,620.08	0.00	0.00	20,249.49	59,191.51	74.51
Education Fund	10 E 1411 2110 00 300 000000	10,030.00	835.86	0.00	0.00	3,477.23	6,552.77	65.33
Education Fund	10 E 1411 2220 00 300 000000	17,819.56	2,333.02	0.00	0.00	-1,985.93	19,805.49	111.14
Education Fund	10 E 1411 2230 00 300 000000	0.00	34.12	0.00	0.00	-102.36	102.36	0.00
Education Fund	10 E 1411 3900 00 300 000000	0.00	0.00	0.00	0.00	0.00	0.00	0.00
Education Fund	10 E 1411 4100 00 300 000000	0.00	0.00	0.00	0.00	0.00	0.00	0.00
Education Fund	10 E 1411 5400 00 300 000000	0.00	0.00	0.00	0.00	0.00	0.00	0.00
Education Fund	10 E 1417 1000 00 300 000000	53,702.00	5,975.24	0.00	0.00	10,158.84	43,543.16	81.08
Education Fund	10 E 1417 2210 00 300 000000	592.58	0.00	0.00	-0.52	318.47	274.63	46.34
Education Fund	10 E 1417 2220 00 300 000000	25,874.47	2,333.02	0.00	0.00	6,068.98	19,805.49	76.54
Education Fund	10 E 1417 2230 00 300 000000	0.00	36.80	0.00	0.00	-110.40	110.40	0.00
Education Fund	10 E 1417 3320 00 300 000000	500.00	0.00	0.00	0.00	500.00	0.00	0.00
Education Fund	10 E 1417 3900 00 300 000000	35,000.00	0.00	0.00	0.00	24,500.00	10,500.00	30.00
Education Fund	10 E 1417 4100 00 300 000000	12,000.00	0.00	1,182.31	0.00	1,456.93	9,360.76	78.01
Education Fund	10 E 1417 5400 00 300 000000	0.00	0.00	0.00	0.00	0.00	0.00	0.00
Education Fund	10 E 1417 6400 00 300 000000	0.00	0.00	0.00	0.00	0.00	0.00	0.00

Expenditure Report

Fiscal Year: 2020-2021
Month: March

COUNTY OF GRUNDY SCHOOL DIST 111

Fund Description	Account Number	Revised Budget	MTD Activity	Encumbrance	Pending Activity	Available Funds	Year to Date Activity	Percent of Budget Used
Education Fund	10 E 1420 1100 09 300 000000	203,446.00	11,842.84	0.00	55.20	73,552.37	129,838.43	63.82
Education Fund	10 E 1420 2110 09 300 000000	25,687.00	1,495.32	0.00	0.00	11,625.66	14,061.34	54.74
Education Fund	10 E 1420 2220 09 300 000000	32,538.28	2,346.08	0.00	-12.52	8,248.18	24,302.62	74.69
Education Fund	10 E 1420 2230 09 300 000000	0.00	73.60	0.00	0.00	-220.80	220.80	0.00
Education Fund	10 E 1420 3230 09 300 000000	1,500.00	0.00	0.00	0.00	1,500.00	0.00	0.00
Education Fund	10 E 1420 3230 09 302 000000	0.00	0.00	0.00	0.00	0.00	0.00	0.00
Education Fund	10 E 1420 4100 09 300 000000	37,500.00	1,203.16	295.74	3,296.21	24,930.10	8,977.95	23.94
Education Fund	10 E 1420 4100 09 300 000001	0.00	0.00	0.00	0.00	0.00	0.00	0.00
Education Fund	10 E 1420 4100 09 302 000000	0.00	0.00	0.00	0.00	0.00	0.00	0.00
Education Fund	10 E 1420 4100 09 302 000001	0.00	0.00	0.00	0.00	0.00	0.00	0.00
Education Fund	10 E 1420 4200 09 300 000000	0.00	0.00	0.00	0.00	0.00	0.00	0.00
Education Fund	10 E 1420 4200 09 302 000000	0.00	0.00	0.00	0.00	0.00	0.00	0.00
Education Fund	10 E 1420 4400 09 300 000000	0.00	0.00	0.00	0.00	0.00	0.00	0.00
Education Fund	10 E 1420 4400 09 302 000000	0.00	0.00	0.00	0.00	0.00	0.00	0.00
Education Fund	10 E 1420 4700 09 300 000000	0.00	0.00	0.00	0.00	0.00	0.00	0.00
Education Fund	10 E 1420 4700 09 302 000000	0.00	0.00	0.00	0.00	0.00	0.00	0.00
Education Fund	10 E 1420 5400 09 300 000000	0.00	0.00	0.00	0.00	0.00	0.00	0.00
Education Fund	10 E 1420 5400 09 302 000000	0.00	0.00	0.00	0.00	0.00	0.00	0.00
Education Fund	10 E 1420 6400 09 300 000000	0.00	0.00	0.00	0.00	0.00	0.00	0.00
Education Fund	10 E 1420 6400 09 302 000000	0.00	0.00	0.00	0.00	0.00	0.00	0.00
Education Fund	10 E 1421 4100 00 300 000000	0.00	0.00	0.00	0.00	0.00	0.00	0.00
Education Fund	10 E 1421 4700 00 300 000000	0.00	0.00	0.00	0.00	0.00	0.00	0.00
Education Fund	10 E 1421 5400 00 300 000000	0.00	0.00	0.00	0.00	0.00	0.00	0.00
Education Fund	10 E 1500 1100 30 300 000000	131,450.00	10,954.16	0.00	0.00	32,862.56	98,587.44	75.00
Education Fund	10 E 1500 1100 30 300 000001	47,397.00	3,949.82	0.00	0.00	11,848.62	35,548.38	75.00
Education Fund	10 E 1500 1100 30 300 000002	15,812.00	1,317.68	0.00	0.00	3,885.63	11,926.37	75.43
Education Fund	10 E 1500 1100 70 300 000000	89,504.00	7,458.74	0.00	0.00	22,805.66	66,698.34	74.52
Education Fund	10 E 1500 1100 70 300 000001	45,395.00	3,782.92	0.00	0.00	10,631.66	34,763.34	76.58
Education Fund	10 E 1500 1100 70 300 000002	15,055.45	1,281.42	0.00	0.00	3,642.01	11,413.44	75.81
Education Fund	10 E 1500 1100 70 300 000003	0.00	0.00	0.00	0.00	0.00	0.00	0.00
Education Fund	10 E 1500 1300 30 300 000000	6,660.00	1,248.00	0.00	0.00	3,132.00	3,528.00	52.97
Education Fund	10 E 1500 1300 30 300 000001	13,516.05	1,146.66	0.00	0.00	3,299.52	10,216.53	75.59
Education Fund	10 E 1500 1300 30 300 000002	47,111.70	9,870.48	0.00	0.00	32,807.70	14,304.00	30.36

248

Expenditure Report

Fiscal Year: 2020-2021
Month: March

COUNTY OF GRUNDY SCHOOL DIST 111

Fund Description	Account Number	Revised Budget	MTD Activity	Encumbrance	Pending Activity	Available Funds	Year to Date Activity	Percent of Budget Used
Education Fund	10 E 1500 1300 30 300 000003	12,460.72	993.48	0.00	0.00	3,519.38	8,941.34	71.76
Education Fund	10 E 1500 1300 30 300 000004	35,181.56	1,294.80	0.00	0.00	22,778.82	12,402.74	35.25
Education Fund	10 E 1500 1300 30 300 000005	9,995.99	757.08	0.00	0.00	3,780.58	6,215.41	62.18
Education Fund	10 E 1500 1300 30 300 000006	28,355.71	2,323.13	0.00	0.00	7,056.44	21,299.27	75.11
Education Fund	10 E 1500 1300 30 300 000007	17,188.08	1,430.00	0.00	0.00	4,416.74	12,771.34	74.30
Education Fund	10 E 1500 1300 30 300 000008	30,887.92	1,625.78	0.00	0.00	11,094.30	19,793.62	64.08
Education Fund	10 E 1500 1300 30 300 000009	24,504.48	2,202.02	0.00	0.00	5,072.05	19,432.43	79.30
Education Fund	10 E 1500 1300 30 300 000010	93,394.80	4,493.28	0.00	0.00	45,512.45	47,882.35	51.27
Education Fund	10 E 1500 1300 30 300 000011	52,948.58	4,122.02	0.00	0.00	16,014.13	36,934.45	69.76
Education Fund	10 E 1500 1300 30 300 000012	30,573.17	6,675.90	0.00	0.00	6,283.19	24,289.98	79.45
Education Fund	10 E 1500 1300 30 300 000013	38,297.76	1,600.80	0.00	0.00	10,901.85	27,395.91	71.53
Education Fund	10 E 1500 1300 30 300 000014	8,720.38	757.08	0.00	0.00	1,577.19	7,143.19	81.91
Education Fund	10 E 1500 1300 30 300 000015	21,774.48	1,804.40	0.00	0.00	5,649.14	16,125.34	74.06
Education Fund	10 E 1500 1300 30 300 000016	27,518.40	6,552.00	0.00	0.00	14,414.40	13,104.00	47.62
Education Fund	10 E 1500 1300 30 300 000017	29,494.94	3,958.96	0.00	0.00	9,209.60	20,285.34	68.78
Education Fund	10 E 1500 1300 30 300 000018	36,059.42	4,448.52	0.00	0.00	12,526.20	23,533.22	65.26
Education Fund	10 E 1500 1300 30 300 000019	11,071.88	2,564.19	0.00	0.00	1,882.55	9,189.33	83.00
Education Fund	10 E 1500 1300 30 300 000020	10,945.31	708.90	0.00	0.00	5,115.99	5,829.32	53.26
Education Fund	10 E 1500 1300 30 300 000021	35,231.16	2,476.93	0.00	0.00	14,693.13	20,538.03	58.30
Education Fund	10 E 1500 1300 30 300 000022	33,287.88	1,736.84	0.00	0.00	17,175.94	16,111.94	48.40
Education Fund	10 E 1500 1300 30 300 000023	0.00	0.00	0.00	0.00	0.00	0.00	0.00
Education Fund	10 E 1500 1300 30 300 000024	9,786.17	0.00	0.00	0.00	9,786.17	0.00	0.00
Education Fund	10 E 1500 1300 30 300 000025	3,646.62	0.00	0.00	0.00	3,646.62	0.00	0.00
Education Fund	10 E 1500 1300 30 300 000026	18,456.94	0.00	0.00	0.00	18,456.94	0.00	0.00
Education Fund	10 E 1500 1300 30 300 000027	11,946.76	0.00	0.00	0.00	11,946.76	0.00	0.00
Education Fund	10 E 1500 1300 70 300 000000	2,852.64	226.40	0.00	0.00	815.04	2,037.60	71.43
Education Fund	10 E 1500 1300 70 300 000001	8,206.80	0.00	0.00	0.00	5,346.80	2,860.00	34.85
Education Fund	10 E 1500 1300 70 300 000002	5,939.12	499.64	0.00	0.00	1,484.80	4,454.32	75.00
Education Fund	10 E 1500 1300 70 300 000003	15,516.88	883.24	0.00	0.00	12,168.23	3,348.65	21.58
Education Fund	10 E 1500 1300 70 300 000004	4,931.21	393.56	0.00	0.00	1,389.25	3,541.96	71.83
Education Fund	10 E 1500 1300 70 300 000005	11,879.95	967.72	0.00	0.00	3,406.83	8,473.12	71.32
Education Fund	10 E 1500 1300 70 300 000006	5,423.88	438.74	0.00	0.00	1,666.43	3,757.45	69.28
Education Fund	10 E 1500 1300 70 300 000007	0.00	0.00	0.00	0.00	0.00	0.00	0.00

249

Expenditure Report

Fiscal Year: 2020-2021
Month: March

COUNTY OF GRUNDY SCHOOL DIST 111

Fund Description	Account Number	Revised Budget	MTD Activity	Encumbrance	Pending Activity	Available Funds	Year to Date Activity	Percent of Budget Used
Education Fund	10 E 1500 1300 70 300 000008	2,317.77	183.96	0.00	0.00	662.21	1,655.56	71.43
Education Fund	10 E 1500 1300 70 300 000009	20,348.55	1,677.24	0.00	0.00	5,333.46	15,015.09	73.79
Education Fund	10 E 1500 1300 70 300 000010	9,828.00	780.00	0.00	0.00	2,808.00	7,020.00	71.43
Education Fund	10 E 1500 1300 70 300 000011	11,977.08	1,015.94	0.00	0.00	2,924.82	9,052.26	75.58
Education Fund	10 E 1500 1300 70 300 000012	5,398.47	426.26	0.00	0.00	1,562.05	3,836.42	71.06
Education Fund	10 E 1500 1300 70 300 000013	7,810.46	647.08	0.00	0.00	2,019.71	5,790.75	74.14
Education Fund	10 E 1500 1300 70 300 000014	0.00	0.00	0.00	0.00	0.00	0.00	0.00
Education Fund	10 E 1500 1300 70 300 000015	12,315.59	969.24	0.00	0.00	3,592.31	8,723.28	70.83
Education Fund	10 E 1500 1300 70 300 000016	2,200.80	174.66	0.00	0.00	628.78	1,572.02	71.43
Education Fund	10 E 1500 1300 70 300 000017	14,522.94	262.00	0.00	0.00	11,531.84	2,991.10	20.60
Education Fund	10 E 1500 1300 70 300 000018	2,200.80	192.12	0.00	0.00	497.96	1,702.84	77.37
Education Fund	10 E 1500 1300 70 300 000019	0.00	0.00	0.00	0.00	0.00	0.00	0.00
Education Fund	10 E 1500 1300 70 300 000020	0.00	0.00	0.00	0.00	0.00	0.00	0.00
Education Fund	10 E 1500 1300 70 300 000021	7,098.00	606.68	0.00	0.00	1,702.76	5,395.24	76.01
Education Fund	10 E 1500 1300 70 300 000022	2,200.80	174.66	0.00	0.00	628.78	1,572.02	71.43
Education Fund	10 E 1500 1300 70 300 000023	7,029.75	563.32	0.00	0.00	1,959.71	5,070.04	72.12
Education Fund	10 E 1500 1300 70 300 000024	0.00	0.00	0.00	0.00	0.00	0.00	0.00
Education Fund	10 E 1500 1300 70 300 000025	2,139.48	169.80	0.00	0.00	611.28	1,528.20	71.43
Education Fund	10 E 1500 1300 70 300 000026	10,428.29	891.00	0.00	0.00	2,431.25	7,997.04	76.69
Education Fund	10 E 1500 1300 70 300 000027	5,220.60	431.80	0.00	0.00	1,360.63	3,859.97	73.94
Education Fund	10 E 1500 1300 70 300 000028	5,025.41	0.00	0.00	0.00	5,025.41	0.00	0.00
Education Fund	10 E 1500 1300 70 300 000029	1,827.47	141.50	0.00	0.00	553.97	1,273.50	69.69
Education Fund	10 E 1500 1300 70 300 000030	2,861.04	227.06	0.00	0.00	817.42	2,043.62	71.43
Education Fund	10 E 1500 1300 70 300 000031	2,852.64	226.40	0.00	0.00	815.04	2,037.60	71.43
Education Fund	10 E 1500 1300 70 300 000032	5,877.90	488.16	0.00	0.00	1,516.95	4,360.95	74.19
Education Fund	10 E 1500 1300 70 300 000033	2,852.64	226.40	0.00	0.00	815.04	2,037.60	71.43
Education Fund	10 E 1500 1300 70 300 000034	2,200.80	174.66	0.00	0.00	576.45	1,624.35	73.81
Education Fund	10 E 1500 1300 70 300 000035	3,961.44	314.40	0.00	0.00	1,131.84	2,829.60	71.43
Education Fund	10 E 1500 1300 70 300 000036	2,200.80	228.66	0.00	0.00	714.51	1,486.29	67.53
Education Fund	10 E 1500 1300 70 300 000037	1,782.90	0.00	0.00	0.00	1,782.90	0.00	0.00
Education Fund	10 E 1500 1300 70 300 000038	1,947.98	141.50	0.00	0.00	674.48	1,273.50	65.38
Education Fund	10 E 1500 1300 70 300 000039	2,087.70	0.00	0.00	0.00	389.70	1,698.00	81.33
Education Fund	10 E 1500 1300 70 300 000040	0.00	0.00	0.00	0.00	0.00	0.00	0.00

Expenditure Report

Fiscal Year: 2020-2021
Month: March

COUNTY OF GRUNDY SCHOOL DIST 111

Fund Description	Account Number	Revised Budget	MTD Activity	Encumbrance	Pending Activity	Available Funds	Year to Date Activity	Percent of Budget Used
Education Fund	10 E 1500 1300 70 300 000041	0.00	0.00	0.00	0.00	0.00	0.00	0.00
Education Fund	10 E 1500 1300 70 300 000042	1,961.19	169.80	0.00	0.00	454.28	1,506.91	76.84
Education Fund	10 E 1500 1300 70 300 000043	2,968.89	238.34	0.00	0.00	823.87	2,145.02	72.25
Education Fund	10 E 1500 1300 70 300 000044	0.00	0.00	0.00	0.00	0.00	0.00	0.00
Education Fund	10 E 1500 1300 70 300 000045	1,058.40	0.00	0.00	0.00	1,058.40	0.00	0.00
Education Fund	10 E 1500 1300 70 300 000046	7,799.98	673.44	0.00	0.00	2,096.53	5,703.45	73.12
Education Fund	10 E 1500 1300 70 300 000047	1,803.17	169.80	0.00	0.00	317.42	1,485.75	82.40
Education Fund	10 E 1500 1300 70 300 000048	1,782.90	0.00	0.00	0.00	1,782.90	0.00	0.00
Education Fund	10 E 1500 1300 70 300 000049	4,338.02	448.34	0.00	0.00	692.54	3,645.48	84.04
Education Fund	10 E 1500 1300 70 300 000050	2,200.80	192.14	0.00	0.00	497.68	1,703.12	77.39
Education Fund	10 E 1500 1300 70 300 000051	17,857.88	0.00	0.00	0.00	12,683.39	5,174.49	28.98
Education Fund	10 E 1500 1300 70 300 000052	1,961.19	0.00	0.00	0.00	1,961.19	0.00	0.00
Education Fund	10 E 1500 1300 70 300 000053	2,613.44	209.60	0.00	0.00	727.04	1,886.40	72.18
Education Fund	10 E 1500 1300 70 300 000054	5,460.00	0.00	0.00	0.00	2,188.00	3,272.00	59.93
Education Fund	10 E 1500 2110 00 000 000000	0.00	0.00	0.00	0.00	0.00	0.00	0.00
Education Fund	10 E 1500 2110 30 000 000000	0.00	0.00	0.00	0.00	0.00	0.00	0.00
Education Fund	10 E 1500 2110 30 300 000000	88,017.93	1,571.06	0.00	0.00	74,668.01	13,349.92	15.17
Education Fund	10 E 1500 2110 30 300 000001	0.00	144.80	0.00	0.00	-1,134.11	1,134.11	0.00
Education Fund	10 E 1500 2110 30 300 000002	0.00	958.80	0.00	0.00	-2,611.57	2,611.57	0.00
Education Fund	10 E 1500 2110 30 300 000003	0.00	125.46	0.00	0.00	-985.31	985.31	0.00
Education Fund	10 E 1500 2110 30 300 000004	0.00	163.51	0.00	0.00	-1,306.36	1,306.36	0.00
Education Fund	10 E 1500 2110 30 300 000005	0.00	95.60	0.00	0.00	-733.08	733.08	0.00
Education Fund	10 E 1500 2110 30 300 000006	0.00	293.32	0.00	0.00	-2,095.83	2,095.83	0.00
Education Fund	10 E 1500 2110 30 300 000007	0.00	180.53	0.00	0.00	-1,414.84	1,414.84	0.00
Education Fund	10 E 1500 2110 30 300 000008	0.00	205.28	0.00	0.00	-2,269.61	2,269.61	0.00
Education Fund	10 E 1500 2110 30 300 000009	0.00	278.04	0.00	0.00	-2,172.01	2,172.01	0.00
Education Fund	10 E 1500 2110 30 300 000010	0.00	568.63	0.00	0.00	-4,453.64	4,453.64	0.00
Education Fund	10 E 1500 2110 30 300 000011	0.00	520.46	0.00	0.00	-4,082.61	4,082.61	0.00
Education Fund	10 E 1500 2110 30 300 000012	0.00	545.00	0.00	0.00	-2,199.78	2,199.78	0.00
Education Fund	10 E 1500 2110 30 300 000013	0.00	202.12	0.00	0.00	-1,617.76	1,617.76	0.00
Education Fund	10 E 1500 2110 30 300 000014	0.00	95.60	0.00	0.00	-760.57	760.57	0.00
Education Fund	10 E 1500 2110 30 300 000015	0.00	177.92	0.00	0.00	-1,394.02	1,394.02	0.00
Education Fund	10 E 1500 2110 30 300 000017	0.00	499.87	0.00	0.00	-2,315.35	2,315.35	0.00

Expenditure Report

Fiscal Year: 2020-2021
Month: March

COUNTY OF GRUNDY SCHOOL DIST 111

Fund Description	Account Number	Revised Budget	MTD Activity	Encumbrance	Pending Activity	Available Funds	Year to Date Activity	Percent of Budget Used
Education Fund	10 E 1500 2110 30 300 000018	0.00	262.00	0.00	0.00	-2,015.01	2,015.01	0.00
Education Fund	10 E 1500 2110 30 300 000019	0.00	73.26	0.00	0.00	-575.35	575.35	0.00
Education Fund	10 E 1500 2110 30 300 000020	0.00	89.48	0.00	0.00	-686.38	686.38	0.00
Education Fund	10 E 1500 2110 30 300 000021	0.00	312.74	0.00	0.00	-2,255.02	2,255.02	0.00
Education Fund	10 E 1500 2110 30 300 000022	0.00	220.72	0.00	0.00	-1,993.01	1,993.01	0.00
Education Fund	10 E 1500 2110 70 300 000000	41,980.50	990.84	0.00	0.00	34,186.97	7,793.53	18.56
Education Fund	10 E 1500 2110 70 300 000001	0.00	0.00	0.00	0.00	-361.11	361.11	0.00
Education Fund	10 E 1500 2110 70 300 000002	0.00	224.90	0.00	0.00	-1,761.38	1,761.38	0.00
Education Fund	10 E 1500 2110 70 300 000003	0.00	27.27	0.00	0.00	-233.34	233.34	0.00
Education Fund	10 E 1500 2110 70 300 000004	0.00	49.72	0.00	0.00	-390.43	390.43	0.00
Education Fund	10 E 1500 2110 70 300 000005	0.00	122.16	0.00	0.00	-929.50	929.50	0.00
Education Fund	10 E 1500 2110 70 300 000006	0.00	32.82	0.00	0.00	-265.36	265.36	0.00
Education Fund	10 E 1500 2110 70 300 000008	0.00	23.24	0.00	0.00	-182.52	182.52	0.00
Education Fund	10 E 1500 2110 70 300 000009	0.00	211.80	0.00	0.00	-1,661.01	1,661.01	0.00
Education Fund	10 E 1500 2110 70 300 000010	0.00	98.48	0.00	0.00	-773.40	773.40	0.00
Education Fund	10 E 1500 2110 70 300 000011	0.00	130.18	0.00	0.00	-1,021.88	1,021.88	0.00
Education Fund	10 E 1500 2110 70 300 000012	0.00	53.84	0.00	0.00	-422.85	422.85	0.00
Education Fund	10 E 1500 2110 70 300 000013	0.00	82.76	0.00	0.00	-650.22	650.22	0.00
Education Fund	10 E 1500 2110 70 300 000015	0.00	122.38	0.00	0.00	-961.10	961.10	0.00
Education Fund	10 E 1500 2110 70 300 000016	0.00	22.04	0.00	0.00	-173.12	173.12	0.00
Education Fund	10 E 1500 2110 70 300 000017	0.00	33.09	0.00	0.00	-280.60	280.60	0.00
Education Fund	10 E 1500 2110 70 300 000018	0.00	24.28	0.00	0.00	-189.93	189.93	0.00
Education Fund	10 E 1500 2110 70 300 000021	0.00	76.62	0.00	0.00	-599.52	599.52	0.00
Education Fund	10 E 1500 2110 70 300 000022	0.00	22.06	0.00	0.00	-173.25	173.25	0.00
Education Fund	10 E 1500 2110 70 300 000023	0.00	71.10	0.00	0.00	-558.38	558.38	0.00
Education Fund	10 E 1500 2110 70 300 000025	0.00	21.44	0.00	0.00	-168.37	168.37	0.00
Education Fund	10 E 1500 2110 70 300 000026	0.00	112.50	0.00	0.00	-882.82	882.82	0.00
Education Fund	10 E 1500 2110 70 300 000027	0.00	54.48	0.00	0.00	-427.15	427.15	0.00
Education Fund	10 E 1500 2110 70 300 000029	0.00	17.88	0.00	0.00	-140.43	140.43	0.00
Education Fund	10 E 1500 2110 70 300 000030	0.00	28.68	0.00	0.00	-225.24	225.24	0.00
Education Fund	10 E 1500 2110 70 300 000031	0.00	28.58	0.00	0.00	-224.43	224.43	0.00
Education Fund	10 E 1500 2110 70 300 000032	0.00	61.64	0.00	0.00	-483.14	483.14	0.00
Education Fund	10 E 1500 2110 70 300 000033	0.00	28.60	0.00	0.00	-224.58	224.58	0.00

252

Expenditure Report

Fiscal Year: 2020-2021
Month: March

COUNTY OF GRUNDY SCHOOL DIST 111

Fund Description	Account Number	Revised Budget	MTD Activity	Encumbrance	Pending Activity	Available Funds	Year to Date Activity	Percent of Budget Used
Education Fund	10 E 1500 2110 70 300 000034	0.00	22.06	0.00	0.00	-174.81	174.81	0.00
Education Fund	10 E 1500 2110 70 300 000035	0.00	39.70	0.00	0.00	-311.77	311.77	0.00
Education Fund	10 E 1500 2110 70 300 000036	0.00	28.88	0.00	0.00	-187.72	187.72	0.00
Education Fund	10 E 1500 2110 70 300 000038	0.00	17.88	0.00	0.00	-140.43	140.43	0.00
Education Fund	10 E 1500 2110 70 300 000042	0.00	21.44	0.00	0.00	-167.78	167.78	0.00
Education Fund	10 E 1500 2110 70 300 000043	0.00	30.10	0.00	0.00	-236.38	236.38	0.00
Education Fund	10 E 1500 2110 70 300 000046	0.00	54.96	0.00	0.00	-431.64	431.64	0.00
Education Fund	10 E 1500 2110 70 300 000047	0.00	21.45	0.00	0.00	-167.24	167.24	0.00
Education Fund	10 E 1500 2110 70 300 000049	0.00	22.04	0.00	0.00	-181.88	181.88	0.00
Education Fund	10 E 1500 2110 70 300 000050	0.00	24.26	0.00	0.00	-189.75	189.75	0.00
Education Fund	10 E 1500 2110 70 300 000051	0.00	0.00	0.00	0.00	-1,311.91	1,311.91	0.00
Education Fund	10 E 1500 2110 70 300 000053	0.00	26.46	0.00	0.00	-207.81	207.81	0.00
Education Fund	10 E 1500 2210 30 300 000000	0.00	0.00	0.00	0.00	0.00	0.00	0.00
Education Fund	10 E 1500 2210 70 300 000000	0.00	0.00	0.00	0.00	0.00	0.00	0.00
Education Fund	10 E 1500 2220 00 000 000000	0.00	0.00	0.00	0.00	0.00	0.00	0.00
Education Fund	10 E 1500 2220 00 300 000000	0.00	0.00	0.00	0.00	0.00	0.00	0.00
Education Fund	10 E 1500 2220 30 000 000000	0.00	0.00	0.00	0.00	0.00	0.00	0.00
Education Fund	10 E 1500 2220 30 300 000000	143,520.36	2,349.98	0.00	-11.08	122,562.70	20,968.74	14.61
Education Fund	10 E 1500 2220 30 300 000001	0.00	1,514.16	0.00	0.00	-12,828.69	12,828.69	0.00
Education Fund	10 E 1500 2220 30 300 000002	0.00	184.70	0.00	0.00	-1,646.71	1,646.71	0.00
Education Fund	10 E 1500 2220 30 300 000006	0.00	0.00	0.00	0.00	0.00	0.00	0.00
Education Fund	10 E 1500 2220 30 300 000010	0.00	0.00	0.00	0.00	0.00	0.00	0.00
Education Fund	10 E 1500 2220 30 300 000022	0.00	146.82	0.00	0.00	-1,250.95	1,250.95	0.00
Education Fund	10 E 1500 2220 70 300 000000	71,340.74	16.26	0.00	-7.72	70,724.59	623.87	0.87
Education Fund	10 E 1500 2220 70 300 000001	0.00	2,333.02	0.00	0.00	-19,805.49	19,805.49	0.00
Education Fund	10 E 1500 2220 70 300 000002	0.00	168.96	0.00	0.00	-1,924.11	1,924.11	0.00
Education Fund	10 E 1500 2220 70 300 000051	0.00	0.00	0.00	0.00	-1,074.64	1,074.64	0.00
Education Fund	10 E 1500 2230 30 300 000000	0.00	117.38	0.00	0.00	-352.14	352.14	0.00
Education Fund	10 E 1500 2230 30 300 000001	0.00	36.80	0.00	0.00	-110.40	110.40	0.00
Education Fund	10 E 1500 2230 30 300 000002	0.00	4.80	0.00	0.00	-14.40	14.40	0.00
Education Fund	10 E 1500 2230 70 300 000000	0.00	36.80	0.00	0.00	-110.40	110.40	0.00
Education Fund	10 E 1500 2230 70 300 000001	0.00	36.80	0.00	0.00	-110.40	110.40	0.00
Education Fund	10 E 1500 3000 30 300 000000	0.00	0.00	0.00	0.00	0.00	0.00	0.00

253

Expenditure Report

Fiscal Year: 2020-2021
Month: March

COUNTY OF GRUNDY SCHOOL DIST 111

Fund Description	Account Number	Revised Budget	MTD Activity	Encumbrance	Pending Activity	Available Funds	Year to Date Activity	Percent of Budget Used
Education Fund	10 E 1500 3000 30 300 000001	0.00	0.00	0.00	0.00	0.00	0.00	0.00
Education Fund	10 E 1500 3000 30 300 000002	0.00	0.00	0.00	0.00	0.00	0.00	0.00
Education Fund	10 E 1500 3000 30 300 000003	0.00	0.00	0.00	0.00	0.00	0.00	0.00
Education Fund	10 E 1500 3000 30 300 000004	0.00	0.00	0.00	0.00	0.00	0.00	0.00
Education Fund	10 E 1500 3000 30 300 000005	0.00	0.00	0.00	0.00	0.00	0.00	0.00
Education Fund	10 E 1500 3000 30 300 000006	0.00	0.00	0.00	0.00	0.00	0.00	0.00
Education Fund	10 E 1500 3000 30 300 000007	0.00	0.00	0.00	0.00	0.00	0.00	0.00
Education Fund	10 E 1500 3000 30 300 000008	2,200.00	0.00	0.00	0.00	2,200.00	0.00	0.00
Education Fund	10 E 1500 3000 30 300 000009	2,000.00	0.00	0.00	0.00	2,000.00	0.00	0.00
Education Fund	10 E 1500 3000 30 300 000010	0.00	0.00	0.00	0.00	0.00	0.00	0.00
Education Fund	10 E 1500 3000 30 300 000011	0.00	0.00	0.00	0.00	0.00	0.00	0.00
Education Fund	10 E 1500 3000 30 300 000012	8,000.00	0.00	0.00	297.00	7,703.00	0.00	0.00
Education Fund	10 E 1500 3000 30 300 000013	0.00	0.00	0.00	0.00	0.00	0.00	0.00
Education Fund	10 E 1500 3000 30 300 000014	0.00	1,200.00	0.00	0.00	-1,200.00	1,200.00	0.00
Education Fund	10 E 1500 3000 30 300 000015	25,000.00	0.00	0.00	0.00	10,953.70	14,046.30	56.19
Education Fund	10 E 1500 3000 30 300 000016	0.00	0.00	0.00	0.00	0.00	0.00	0.00
Education Fund	10 E 1500 3000 30 300 000017	0.00	0.00	0.00	0.00	0.00	0.00	0.00
Education Fund	10 E 1500 3000 30 300 000018	0.00	0.00	0.00	0.00	-859.80	859.80	0.00
Education Fund	10 E 1500 3000 30 300 000019	0.00	0.00	0.00	0.00	0.00	0.00	0.00
Education Fund	10 E 1500 3000 30 300 000020	0.00	0.00	0.00	0.00	0.00	0.00	0.00
Education Fund	10 E 1500 3000 30 300 000021	4,000.00	0.00	0.00	0.00	4,000.00	0.00	0.00
Education Fund	10 E 1500 3000 30 300 000022	0.00	0.00	0.00	0.00	0.00	0.00	0.00
Education Fund	10 E 1500 3000 30 300 000023	24,000.00	0.00	0.00	9,320.00	-6,414.00	21,094.00	87.89
Education Fund	10 E 1500 3000 70 000 000000	0.00	0.00	0.00	0.00	0.00	0.00	0.00
Education Fund	10 E 1500 3000 70 000 000001	0.00	0.00	0.00	0.00	0.00	0.00	0.00
Education Fund	10 E 1500 3000 70 000 000002	0.00	0.00	0.00	0.00	0.00	0.00	0.00
Education Fund	10 E 1500 3000 70 000 000003	0.00	0.00	0.00	0.00	0.00	0.00	0.00
Education Fund	10 E 1500 3000 70 000 000004	0.00	0.00	0.00	0.00	0.00	0.00	0.00
Education Fund	10 E 1500 3000 70 000 000005	0.00	0.00	0.00	0.00	0.00	0.00	0.00
Education Fund	10 E 1500 3000 70 000 000006	0.00	0.00	0.00	0.00	0.00	0.00	0.00
Education Fund	10 E 1500 3000 70 000 000007	0.00	0.00	0.00	0.00	0.00	0.00	0.00
Education Fund	10 E 1500 3000 70 300 000000	11,000.00	6,113.30	0.00	0.00	2,002.01	8,997.99	81.80
Education Fund	10 E 1500 3000 70 300 000001	3,000.00	0.00	325.00	0.00	640.88	2,034.12	67.80

Expenditure Report

Fiscal Year: 2020-2021
Month: March

COUNTY OF GRUNDY SCHOOL DIST 111

Fund Description	Account Number	Revised Budget	MTD Activity	Encumbrance	Pending Activity	Available Funds	Year to Date Activity	Percent of Budget Used
Education Fund	10 E 1500 3000 70 300 000002	2,500.00	0.00	0.00	0.00	608.79	1,891.21	75.65
Education Fund	10 E 1500 3000 70 300 000003	5,000.00	0.00	0.00	0.00	5,000.00	0.00	0.00
Education Fund	10 E 1500 3000 70 300 000004	1,500.00	0.00	0.00	0.00	1,500.00	0.00	0.00
Education Fund	10 E 1500 3000 70 300 000005	0.00	0.00	0.00	0.00	0.00	0.00	0.00
Education Fund	10 E 1500 3000 70 300 000006	2,000.00	0.00	0.00	0.00	2,000.00	0.00	0.00
Education Fund	10 E 1500 3000 70 300 000007	0.00	0.00	0.00	0.00	0.00	0.00	0.00
Education Fund	10 E 1500 3000 70 300 000008	0.00	0.00	0.00	0.00	-290.00	290.00	0.00
Education Fund	10 E 1500 3000 70 300 000009	0.00	0.00	0.00	0.00	0.00	0.00	0.00
Education Fund	10 E 1500 3000 70 300 000010	250.00	0.00	0.00	0.00	250.00	0.00	0.00
Education Fund	10 E 1500 3000 70 300 000011	1,200.00	100.00	0.00	0.00	1,100.00	100.00	8.33
Education Fund	10 E 1500 3000 70 300 000012	0.00	0.00	0.00	0.00	0.00	0.00	0.00
Education Fund	10 E 1500 3000 70 300 000013	1,200.00	0.00	0.00	0.00	1,200.00	0.00	0.00
Education Fund	10 E 1500 3000 70 300 000014	50,000.00	825.08	0.00	0.00	55,498.99	-5,498.99	-11.00
Education Fund	10 E 1500 3190 30 300 000000	2,822.40	0.00	798.00	0.00	2,024.40	0.00	255 0.00
Education Fund	10 E 1500 3190 30 300 000001	3,614.10	0.00	1,268.00	0.00	2,346.10	0.00	0.00
Education Fund	10 E 1500 3190 30 300 000002	0.00	0.00	0.00	0.00	0.00	0.00	0.00
Education Fund	10 E 1500 3190 30 300 000003	5,217.45	0.00	2,282.00	0.00	2,935.45	0.00	0.00
Education Fund	10 E 1500 3190 30 300 000004	6,805.05	2,519.00	734.00	0.00	3,552.05	2,519.00	37.02
Education Fund	10 E 1500 3190 30 300 000005	4,625.25	1,866.00	628.00	0.00	2,131.25	1,866.00	40.34
Education Fund	10 E 1500 3190 30 300 000006	2,710.05	0.00	0.00	0.00	2,710.05	0.00	0.00
Education Fund	10 E 1500 3190 30 300 000007	756.00	0.00	0.00	0.00	756.00	0.00	0.00
Education Fund	10 E 1500 3190 30 300 000008	449.40	0.00	0.00	0.00	-425.60	875.00	194.70
Education Fund	10 E 1500 3190 30 300 000009	81.90	0.00	0.00	0.00	81.90	0.00	0.00
Education Fund	10 E 1500 3190 30 300 000010	0.00	0.00	0.00	0.00	0.00	0.00	0.00
Education Fund	10 E 1500 3190 30 300 000011	0.00	0.00	0.00	0.00	-20.00	20.00	0.00
Education Fund	10 E 1500 3190 30 300 000012	192.15	0.00	0.00	0.00	192.15	0.00	0.00
Education Fund	10 E 1500 3190 30 300 000013	304.50	0.00	0.00	0.00	304.50	0.00	0.00
Education Fund	10 E 1500 3190 30 300 000014	0.00	0.00	0.00	0.00	0.00	0.00	0.00
Education Fund	10 E 1500 3190 70 300 000000	1,443.75	0.00	0.00	0.00	833.75	610.00	42.25
Education Fund	10 E 1500 3220 30 300 000000	0.00	0.00	0.00	0.00	0.00	0.00	0.00
Education Fund	10 E 1500 3320 30 300 000000	0.00	0.00	0.00	0.00	0.00	0.00	0.00
Education Fund	10 E 1500 3320 30 300 000001	175.00	0.00	0.00	0.00	175.00	0.00	0.00
Education Fund	10 E 1500 3320 70 300 000000	3,390.91	250.33	0.00	0.00	3,140.58	250.33	7.38

Expenditure Report

Fiscal Year: 2020-2021
Month: March

COUNTY OF GRUNDY SCHOOL DIST 111

Fund Description	Account Number	Revised Budget	MTD Activity	Encumbrance	Pending Activity	Available Funds	Year to Date Activity	Percent of Budget Used
Education Fund	10 E 1500 3320 70 300 000001	408.39	0.00	0.00	0.00	326.31	82.08	20.10
Education Fund	10 E 1500 3900 30 300 000000	20,000.00	43.62	160.00	2,485.00	20,976.38	-3,621.38	-18.11
Education Fund	10 E 1500 3900 30 300 000001	30,000.00	0.00	0.00	2,980.80	23,113.99	3,905.21	13.02
Education Fund	10 E 1500 3900 30 300 000002	0.00	0.00	0.00	0.00	2,300.00	-2,300.00	0.00
Education Fund	10 E 1500 4100 30 300 000000	6,500.00	0.00	0.00	0.00	612.00	5,888.00	90.58
Education Fund	10 E 1500 4100 30 300 000001	1,000.00	0.00	0.00	0.00	-1,186.98	2,186.98	218.70
Education Fund	10 E 1500 4100 30 300 000002	1,000.00	1,000.00	0.00	0.00	0.00	1,000.00	100.00
Education Fund	10 E 1500 4100 30 300 000003	1,500.00	0.00	0.00	0.00	1,500.00	0.00	0.00
Education Fund	10 E 1500 4100 30 300 000004	2,000.00	0.00	0.00	0.00	2,000.00	0.00	0.00
Education Fund	10 E 1500 4100 30 300 000005	3,800.00	0.00	0.00	0.00	3,800.00	0.00	0.00
Education Fund	10 E 1500 4100 30 300 000006	1,700.00	0.00	0.00	0.00	963.20	736.80	43.34
Education Fund	10 E 1500 4100 30 300 000007	2,000.00	0.00	0.00	0.00	2,000.00	0.00	0.00
Education Fund	10 E 1500 4100 30 300 000008	4,500.00	0.00	0.00	0.00	-895.80	5,395.80	119.91
Education Fund	10 E 1500 4100 30 300 000009	3,300.00	255.22	0.00	0.00	3,044.78	255.22	7.73
Education Fund	10 E 1500 4100 30 300 000010	4,500.00	0.00	4,100.00	0.00	0.00	400.00	8.89
Education Fund	10 E 1500 4100 30 300 000011	4,500.00	0.00	0.00	0.00	3,578.00	922.00	20.49
Education Fund	10 E 1500 4100 30 300 000012	2,000.00	0.00	0.00	0.00	2,000.00	0.00	0.00
Education Fund	10 E 1500 4100 30 300 000013	2,000.00	0.00	0.00	0.00	-12.94	2,012.94	100.65
Education Fund	10 E 1500 4100 30 300 000014	1,400.00	0.00	0.00	0.00	850.22	549.78	39.27
Education Fund	10 E 1500 4100 30 300 000015	1,750.00	0.00	0.00	0.00	-156.05	1,906.05	108.92
Education Fund	10 E 1500 4100 30 300 000016	1,350.00	0.00	0.00	0.00	67.61	1,282.39	94.99
Education Fund	10 E 1500 4100 30 300 000017	5,500.00	0.00	0.00	0.00	2,607.42	2,892.58	52.59
Education Fund	10 E 1500 4100 30 300 000018	40,000.00	0.00	0.00	0.00	12.88	39,987.12	99.97
Education Fund	10 E 1500 4100 30 300 000019	200.00	0.00	0.00	0.00	200.00	0.00	0.00
Education Fund	10 E 1500 4100 30 300 000020	2,500.00	0.00	0.00	0.00	858.45	1,641.55	65.66
Education Fund	10 E 1500 4100 30 300 000021	22,500.00	0.00	0.00	0.00	15,074.03	7,425.97	33.00
Education Fund	10 E 1500 4100 30 300 000022	3,700.00	0.00	0.00	0.00	2,642.41	1,057.59	28.58
Education Fund	10 E 1500 4100 30 300 000023	1,400.00	0.00	0.00	0.00	1,400.00	0.00	0.00
Education Fund	10 E 1500 4100 30 300 000024	200.00	0.00	0.00	0.00	200.00	0.00	0.00
Education Fund	10 E 1500 4100 30 300 000025	0.00	0.00	0.00	0.00	0.00	0.00	0.00
Education Fund	10 E 1500 4100 30 300 000026	4,000.00	0.00	741.00	1,680.00	1,579.00	0.00	0.00
Education Fund	10 E 1500 4100 30 300 000027	0.00	0.00	0.00	0.00	0.00	0.00	0.00
Education Fund	10 E 1500 4100 30 300 000028	0.00	0.00	0.00	0.00	0.00	0.00	0.00

Expenditure Report

Fiscal Year: 2020-2021
Month: March

COUNTY OF GRUNDY SCHOOL DIST 111

Fund Description	Account Number	Revised Budget	MTD Activity	Encumbrance	Pending Activity	Available Funds	Year to Date Activity	Percent of Budget Used
Education Fund	10 E 1500 4100 30 300 000029	0.00	0.00	0.00	0.00	-696.00	696.00	0.00
Education Fund	10 E 1500 4100 30 300 000030	0.00	0.00	0.00	0.00	0.00	0.00	0.00
Education Fund	10 E 1500 4100 30 300 000031	0.00	0.00	0.00	0.00	0.00	0.00	0.00
Education Fund	10 E 1500 4100 30 300 000032	1,800.00	0.00	0.00	0.00	1,800.00	0.00	0.00
Education Fund	10 E 1500 4100 30 300 000033	1,800.00	0.00	0.00	0.00	1,800.00	0.00	0.00
Education Fund	10 E 1500 4100 30 300 000034	5,100.00	0.00	0.00	0.00	5,100.00	0.00	0.00
Education Fund	10 E 1500 4100 30 300 000035	0.00	0.00	0.00	0.00	-1,096.00	1,096.00	0.00
Education Fund	10 E 1500 4100 30 300 000036	4,400.00	116.58	4,096.65	-69.00	255.77	116.58	2.65
Education Fund	10 E 1500 4100 30 300 000037	0.00	0.00	0.00	0.00	0.00	0.00	0.00
Education Fund	10 E 1500 4100 30 300 000038	0.00	0.00	0.00	0.00	0.00	0.00	0.00
Education Fund	10 E 1500 4100 30 300 000039	2,500.00	0.00	0.00	0.00	3.00	2,497.00	99.88
Education Fund	10 E 1500 4100 30 300 000040	2,500.00	0.00	0.00	0.00	2,500.00	0.00	0.00
Education Fund	10 E 1500 4100 30 300 000041	4,500.00	0.00	0.00	0.00	4,500.00	0.00	0.00
Education Fund	10 E 1500 4100 30 300 000042	5,500.00	0.00	0.00	0.00	5,500.00	0.00	0.00
Education Fund	10 E 1500 4100 30 300 000043	0.00	0.00	0.00	0.00	0.00	0.00	0.00
Education Fund	10 E 1500 4100 30 300 000044	0.00	0.00	0.00	0.00	0.00	0.00	0.00
Education Fund	10 E 1500 4100 30 300 000045	0.00	0.00	0.00	0.00	0.00	0.00	0.00
Education Fund	10 E 1500 4100 30 300 000046	0.00	0.00	0.00	0.00	0.00	0.00	0.00
Education Fund	10 E 1500 4100 30 300 000047	2,500.00	0.00	0.00	0.00	2,500.00	0.00	0.00
Education Fund	10 E 1500 4100 30 300 000048	2,500.00	0.00	0.00	0.00	2,500.00	0.00	0.00
Education Fund	10 E 1500 4100 30 300 000049	0.00	0.00	0.00	0.00	0.00	0.00	0.00
Education Fund	10 E 1500 4100 70 000 000000	0.00	0.00	0.00	0.00	0.00	0.00	0.00
Education Fund	10 E 1500 4100 70 000 000001	0.00	0.00	0.00	0.00	0.00	0.00	0.00
Education Fund	10 E 1500 4100 70 000 000002	0.00	0.00	0.00	0.00	0.00	0.00	0.00
Education Fund	10 E 1500 4100 70 000 000003	0.00	0.00	0.00	0.00	0.00	0.00	0.00
Education Fund	10 E 1500 4100 70 300 000000	100.00	0.00	0.00	0.00	100.00	0.00	0.00
Education Fund	10 E 1500 4100 70 300 000001	100.00	0.00	0.00	0.00	80.50	19.50	19.50
Education Fund	10 E 1500 4100 70 300 000002	100.00	0.00	0.00	0.00	100.00	0.00	0.00
Education Fund	10 E 1500 4100 70 300 000003	1,500.00	0.00	0.00	0.00	807.00	693.00	46.20
Education Fund	10 E 1500 4100 70 300 000004	5,000.00	1,266.69	0.00	231.05	3,502.26	1,266.69	25.33
Education Fund	10 E 1500 4100 70 300 000005	1,400.00	0.00	0.00	0.00	1,221.81	178.19	12.73
Education Fund	10 E 1500 4100 70 300 000006	1,800.00	307.73	0.00	0.00	1,280.71	519.29	28.85
Education Fund	10 E 1500 4100 70 300 000007	500.00	0.00	0.00	0.00	481.03	18.97	3.79

257

Expenditure Report

Fiscal Year: 2020-2021
Month: March

COUNTY OF GRUNDY SCHOOL DIST 111

Fund Description	Account Number	Revised Budget	MTD Activity	Encumbrance	Pending Activity	Available Funds	Year to Date Activity	Percent of Budget Used
Education Fund	10 E 1500 4100 70 300 000008	1,000.00	0.00	0.00	0.00	1,000.00	0.00	0.00
Education Fund	10 E 1500 4100 70 300 000009	0.00	0.00	0.00	0.00	0.00	0.00	0.00
Education Fund	10 E 1500 4100 70 300 000010	5,000.00	2,820.00	1,672.20	0.00	507.80	2,820.00	56.40
Education Fund	10 E 1500 4100 70 300 000011	100.00	0.00	0.00	0.00	100.00	0.00	0.00
Education Fund	10 E 1500 4100 70 300 000012	0.00	0.00	0.00	0.00	0.00	0.00	0.00
Education Fund	10 E 1500 4100 70 300 000013	100.00	0.00	0.00	0.00	100.00	0.00	0.00
Education Fund	10 E 1500 4100 70 300 000014	100.00	0.00	0.00	0.00	0.56	99.44	99.44
Education Fund	10 E 1500 4100 70 300 000015	100.00	0.00	0.00	0.00	100.00	0.00	0.00
Education Fund	10 E 1500 4100 70 300 000016	100.00	0.00	0.00	0.00	100.00	0.00	0.00
Education Fund	10 E 1500 4100 70 300 000017	100.00	0.00	0.00	0.00	100.00	0.00	0.00
Education Fund	10 E 1500 4100 70 300 000018	0.00	0.00	0.00	0.00	0.00	0.00	0.00
Education Fund	10 E 1500 4100 70 300 000019	250.00	0.00	0.00	0.00	250.00	0.00	0.00
Education Fund	10 E 1500 4100 70 300 000020	400.00	0.00	0.00	0.00	400.00	0.00	0.00
Education Fund	10 E 1500 4100 70 300 000021	3,000.00	0.00	0.00	-77.77	2,674.74	403.03	13.43
Education Fund	10 E 1500 4100 70 300 000022	500.00	0.00	0.00	0.00	371.00	129.00	25.80
Education Fund	10 E 1500 4100 70 300 000023	100.00	0.00	0.00	0.00	100.00	0.00	0.00
Education Fund	10 E 1500 4100 70 300 000024	500.00	110.83	0.00	-200.50	188.67	511.83	102.37
Education Fund	10 E 1500 4400 70 300 000000	0.00	0.00	0.00	0.00	0.00	0.00	0.00
Education Fund	10 E 1500 4700 70 300 000000	0.00	0.00	0.00	0.00	0.00	0.00	0.00
Education Fund	10 E 1500 5400 30 300 000000	0.00	0.00	0.00	0.00	0.00	0.00	0.00
Education Fund	10 E 1500 5400 30 300 000001	0.00	0.00	0.00	0.00	0.00	0.00	0.00
Education Fund	10 E 1500 5400 30 300 000002	0.00	0.00	0.00	0.00	0.00	0.00	0.00
Education Fund	10 E 1500 5400 30 300 000003	0.00	0.00	0.00	0.00	0.00	0.00	0.00
Education Fund	10 E 1500 5400 30 300 000004	0.00	0.00	0.00	0.00	0.00	0.00	0.00
Education Fund	10 E 1500 5400 30 300 000005	20,000.00	4,686.90	0.00	0.00	6,741.31	13,258.69	66.29
Education Fund	10 E 1500 5400 30 300 000006	0.00	0.00	0.00	0.00	0.00	0.00	0.00
Education Fund	10 E 1500 5400 30 300 000007	0.00	0.00	0.00	0.00	0.00	0.00	0.00
Education Fund	10 E 1500 5400 30 300 000008	0.00	0.00	0.00	0.00	0.00	0.00	0.00
Education Fund	10 E 1500 5400 30 300 000009	0.00	0.00	0.00	0.00	0.00	0.00	0.00
Education Fund	10 E 1500 5400 30 300 000010	0.00	0.00	0.00	0.00	0.00	0.00	0.00
Education Fund	10 E 1500 5400 30 300 000011	0.00	0.00	0.00	0.00	0.00	0.00	0.00
Education Fund	10 E 1500 5400 30 300 000012	0.00	0.00	0.00	0.00	0.00	0.00	0.00
Education Fund	10 E 1500 5400 30 300 000013	0.00	0.00	0.00	0.00	0.00	0.00	0.00

Expenditure Report

Fiscal Year: 2020-2021
Month: March

COUNTY OF GRUNDY SCHOOL DIST 111

Fund Description	Account Number	Revised Budget	MTD Activity	Encumbrance	Pending Activity	Available Funds	Year to Date Activity	Percent of Budget Used
Education Fund	10 E 1500 5400 30 300 000014	0.00	0.00	0.00	0.00	0.00	0.00	0.00
Education Fund	10 E 1500 5400 30 300 000015	0.00	0.00	0.00	0.00	0.00	0.00	0.00
Education Fund	10 E 1500 5400 30 300 000016	0.00	0.00	0.00	0.00	0.00	0.00	0.00
Education Fund	10 E 1500 5400 30 300 000017	0.00	0.00	0.00	0.00	0.00	0.00	0.00
Education Fund	10 E 1500 5400 30 300 000018	0.00	0.00	0.00	0.00	0.00	0.00	0.00
Education Fund	10 E 1500 5400 30 300 000019	0.00	0.00	0.00	0.00	0.00	0.00	0.00
Education Fund	10 E 1500 5400 30 300 000020	0.00	0.00	0.00	0.00	0.00	0.00	0.00
Education Fund	10 E 1500 5400 30 300 000021	0.00	0.00	0.00	0.00	0.00	0.00	0.00
Education Fund	10 E 1500 5400 30 300 000022	0.00	0.00	0.00	0.00	0.00	0.00	0.00
Education Fund	10 E 1500 5400 30 300 000023	0.00	0.00	0.00	0.00	0.00	0.00	0.00
Education Fund	10 E 1500 5400 30 300 000024	5,000.00	0.00	0.00	0.00	5,000.00	0.00	0.00
Education Fund	10 E 1500 5400 30 300 000025	0.00	0.00	0.00	0.00	0.00	0.00	0.00
Education Fund	10 E 1500 5400 70 300 000000	0.00	0.00	0.00	0.00	0.00	0.00	0.00
Education Fund	10 E 1500 5400 70 300 000001	0.00	0.00	0.00	0.00	0.00	0.00	259 0.00
Education Fund	10 E 1500 5400 70 300 000002	0.00	0.00	0.00	0.00	0.00	0.00	0.00
Education Fund	10 E 1500 5400 70 300 000003	5,000.00	0.00	0.00	0.00	251.27	4,748.73	94.97
Education Fund	10 E 1500 6400 30 300 000000	5,500.00	0.00	0.00	0.00	5,415.00	85.00	1.55
Education Fund	10 E 1500 6400 30 300 000001	500.00	0.00	0.00	0.00	500.00	0.00	0.00
Education Fund	10 E 1500 6400 30 300 000002	200.00	0.00	0.00	0.00	-105.00	305.00	152.50
Education Fund	10 E 1500 6400 70 000 000000	0.00	0.00	0.00	0.00	0.00	0.00	0.00
Education Fund	10 E 1500 6400 70 000 000001	0.00	0.00	0.00	0.00	0.00	0.00	0.00
Education Fund	10 E 1500 6400 70 000 000002	0.00	0.00	0.00	0.00	0.00	0.00	0.00
Education Fund	10 E 1500 6400 70 300 000000	1,000.00	30.00	0.00	0.00	540.00	460.00	46.00
Education Fund	10 E 1500 6400 70 300 000001	0.00	0.00	0.00	0.00	0.00	0.00	0.00
Education Fund	10 E 1500 6400 70 300 000002	0.00	0.00	0.00	0.00	0.00	0.00	0.00
Education Fund	10 E 1500 6400 70 300 000003	300.00	0.00	0.00	0.00	150.00	150.00	50.00
Education Fund	10 E 1500 6400 70 300 000004	300.00	0.00	0.00	0.00	140.00	160.00	53.33
Education Fund	10 E 1500 6400 70 300 000005	0.00	0.00	0.00	0.00	0.00	0.00	0.00
Education Fund	10 E 1500 6400 70 300 000006	100.00	0.00	0.00	0.00	100.00	0.00	0.00
Education Fund	10 E 1500 6400 70 300 000007	250.00	0.00	100.00	0.00	150.00	0.00	0.00
Education Fund	10 E 1500 6400 70 300 000008	0.00	0.00	0.00	0.00	0.00	0.00	0.00
Education Fund	10 E 1500 6400 70 300 000009	2,100.00	0.00	50.00	0.00	2,050.00	0.00	0.00
Education Fund	10 E 1500 6400 70 300 000010	1,500.00	0.00	0.00	0.00	1,500.00	0.00	0.00

Expenditure Report

Fiscal Year: 2020-2021
Month: March

COUNTY OF GRUNDY SCHOOL DIST 111

Fund Description	Account Number	Revised Budget	MTD Activity	Encumbrance	Pending Activity	Available Funds	Year to Date Activity	Percent of Budget Used
Education Fund	10 E 1600 1100 00 300 000000	0.00	0.00	0.00	0.00	0.00	0.00	0.00
Education Fund	10 E 1600 2110 00 300 000000	0.00	0.00	0.00	0.00	0.00	0.00	0.00
Education Fund	10 E 1600 2220 00 300 000000	0.00	0.00	0.00	0.00	0.00	0.00	0.00
Education Fund	10 E 1650 3000 00 300 000000	0.00	0.00	0.00	0.00	0.00	0.00	0.00
Education Fund	10 E 1650 4100 00 300 000000	0.00	0.00	0.00	0.00	0.00	0.00	0.00
Education Fund	10 E 1650 5400 00 300 000000	0.00	0.00	0.00	0.00	0.00	0.00	0.00
Education Fund	10 E 1700 1100 21 300 000000	414,650.00	34,554.16	0.00	0.00	74,004.59	340,645.41	82.15
Education Fund	10 E 1700 1110 00 300 000000	22,066.00	0.00	0.00	0.00	8,031.40	14,034.60	63.60
Education Fund	10 E 1700 2110 00 300 000000	2,787.00	0.00	0.00	0.00	1,111.84	1,675.16	60.11
Education Fund	10 E 1700 2110 21 300 000000	52,355.00	4,362.90	0.00	0.00	17,160.52	35,194.48	67.22
Education Fund	10 E 1700 2220 00 300 000000	5,239.82	0.00	0.00	-4.52	5,134.03	110.31	2.11
Education Fund	10 E 1700 2220 21 300 000000	84,463.26	6,644.54	0.00	0.00	27,333.64	57,129.62	67.64
Education Fund	10 E 1700 2230 21 300 000000	0.00	220.80	0.00	0.00	-662.40	662.40	0.00
Education Fund	10 E 1700 3000 21 300 000000	0.00	0.00	0.00	0.00	0.00	0.00	0.00
Education Fund	10 E 1700 3000 21 302 000000	0.00	0.00	0.00	0.00	0.00	0.00	260 0.00
Education Fund	10 E 1700 3230 00 000 000000	0.00	102.99	0.00	0.00	-728.93	728.93	0.00
Education Fund	10 E 1700 3800 21 300 000000	0.00	0.00	0.00	0.00	0.00	0.00	0.00
Education Fund	10 E 1700 4100 21 300 000000	4,173.00	1,595.00	0.00	0.00	1,586.51	2,586.49	61.98
Education Fund	10 E 1700 4100 21 302 000000	0.00	0.00	0.00	0.00	0.00	0.00	0.00
Education Fund	10 E 1700 4100 21 302 000001	0.00	0.00	0.00	0.00	0.00	0.00	0.00
Education Fund	10 E 1700 4200 21 300 000000	1,673.00	0.00	0.00	0.00	-100.60	1,773.60	106.01
Education Fund	10 E 1700 4200 21 302 000000	0.00	0.00	0.00	0.00	0.00	0.00	0.00
Education Fund	10 E 1700 4640 21 300 000000	7,700.00	296.52	0.00	0.00	5,671.45	2,028.55	26.34
Education Fund	10 E 1700 4900 21 300 000000	0.00	0.00	0.00	0.00	0.00	0.00	0.00
Education Fund	10 E 1700 4900 21 302 000000	0.00	0.00	0.00	0.00	0.00	0.00	0.00
Education Fund	10 E 1700 5400 21 300 000000	0.00	0.00	0.00	0.00	0.00	0.00	0.00
Education Fund	10 E 1700 5400 21 302 000000	0.00	0.00	0.00	0.00	0.00	0.00	0.00
Education Fund	10 E 1700 5500 21 300 000000	50,000.00	0.00	0.00	0.00	60,185.57	-10,185.57	-20.37
Education Fund	10 E 1700 6400 21 300 000000	0.00	0.00	0.00	0.00	0.00	0.00	0.00
Education Fund	10 E 1700 6400 21 302 000000	0.00	0.00	0.00	0.00	0.00	0.00	0.00
Education Fund	10 E 1800 1100 00 000 000000	0.00	0.00	0.00	0.00	0.00	0.00	0.00
Education Fund	10 E 1800 2110 00 000 000000	0.00	0.00	0.00	0.00	0.00	0.00	0.00
Education Fund	10 E 1900 1100 00 301 000000	88,394.00	8,338.02	0.00	0.00	14,836.73	73,557.27	83.22

Expenditure Report

Fiscal Year: 2020-2021
Month: March

COUNTY OF GRUNDY SCHOOL DIST 111

Fund Description	Account Number	Revised Budget	MTD Activity	Encumbrance	Pending Activity	Available Funds	Year to Date Activity	Percent of Budget Used
Education Fund	10 E 1900 1100 00 301 000001	32,005.00	2,667.08	0.00	0.00	8,155.57	23,849.43	74.52
Education Fund	10 E 1900 2110 00 301 000000	11,160.00	1,052.78	0.00	0.00	2,860.13	8,299.87	74.37
Education Fund	10 E 1900 2220 00 301 000000	33,733.39	2,333.02	0.00	-4.52	13,579.48	20,158.43	59.76
Education Fund	10 E 1900 2220 00 301 000001	0.00	1,514.16	0.00	0.00	-12,828.69	12,828.69	0.00
Education Fund	10 E 1900 2230 00 301 000000	0.00	36.80	0.00	0.00	-110.40	110.40	0.00
Education Fund	10 E 1900 3000 00 301 000000	0.00	0.00	0.00	0.00	0.00	0.00	0.00
Education Fund	10 E 1900 3320 00 301 000000	0.00	0.00	0.00	0.00	0.00	0.00	0.00
Education Fund	10 E 1900 4100 00 301 000000	0.00	0.00	0.00	0.00	0.00	0.00	0.00
Education Fund	10 E 1900 4100 00 301 000001	0.00	0.00	0.00	0.00	0.00	0.00	0.00
Education Fund	10 E 1900 4200 00 301 000000	0.00	0.00	0.00	0.00	0.00	0.00	0.00
Education Fund	10 E 1900 5400 00 301 000000	0.00	0.00	0.00	0.00	0.00	0.00	0.00
Education Fund	10 E 1900 6400 00 301 000000	0.00	0.00	0.00	0.00	0.00	0.00	0.00
Education Fund	10 E 1912 6700 00 300 000000	1,791,134.00	225,177.86	0.00	0.00	331,059.45	1,460,074.55	81.52
Education Fund	10 E 2100 1100 00 300 000000	0.00	0.00	0.00	0.00	0.00	0.00	0.00
Education Fund	10 E 2100 1100 00 300 000001	40,996.50	3,398.76	0.00	0.00	9,662.68	31,333.82	76.43
Education Fund	10 E 2100 1100 00 302 000000	125,651.76	11,920.64	0.00	0.00	30,366.00	95,285.76	75.83
Education Fund	10 E 2100 1100 00 302 000001	0.00	0.00	0.00	0.00	0.00	0.00	0.00
Education Fund	10 E 2100 1200 00 300 000000	2,952.96	0.00	0.00	0.00	2,952.96	0.00	0.00
Education Fund	10 E 2100 2110 00 300 000000	0.00	0.00	0.00	0.00	0.00	0.00	0.00
Education Fund	10 E 2100 2110 00 300 000001	0.00	0.00	0.00	0.00	0.00	0.00	0.00
Education Fund	10 E 2100 2110 00 302 000000	16,210.52	1,537.92	0.00	0.00	3,741.55	12,468.97	76.92
Education Fund	10 E 2100 2210 00 302 000000	0.00	0.00	0.00	0.00	0.00	0.00	0.00
Education Fund	10 E 2100 2220 00 300 000000	601.15	0.00	0.00	0.00	601.15	0.00	0.00
Education Fund	10 E 2100 2220 00 302 000000	99.84	8.00	0.00	-6.52	31.32	75.04	75.16
Education Fund	10 E 2100 3000 00 300 000000	0.00	0.00	0.00	0.00	0.00	0.00	0.00
Education Fund	10 E 2100 3000 00 302 000000	2,919.51	0.00	0.00	0.00	2,919.51	0.00	0.00
Education Fund	10 E 2100 4000 00 302 000000	350.00	0.00	0.00	0.00	350.00	0.00	0.00
Education Fund	10 E 2100 4100 00 300 000000	250.00	0.00	0.00	0.00	250.00	0.00	0.00
Education Fund	10 E 2100 5400 00 300 000000	0.00	0.00	0.00	0.00	0.00	0.00	0.00
Education Fund	10 E 2100 6400 00 300 000000	0.00	0.00	0.00	0.00	0.00	0.00	0.00
Education Fund	10 E 2100 6400 00 300 000001	0.00	0.00	0.00	0.00	0.00	0.00	0.00
Education Fund	10 E 2100 6400 00 302 000000	400.00	0.00	0.00	0.00	-124.64	524.64	131.16
Education Fund	10 E 2100 6400 00 302 000001	750.00	0.00	0.00	0.00	750.00	0.00	0.00

261

Expenditure Report

Fiscal Year: 2020-2021
Month: March

COUNTY OF GRUNDY SCHOOL DIST 111

Fund Description	Account Number	Revised Budget	MTD Activity	Encumbrance	Pending Activity	Available Funds	Year to Date Activity	Percent of Budget Used
Education Fund	10 E 2110 0000 00 000 000000	0.00	0.00	0.00	0.00	0.00	0.00	0.00
Education Fund	10 E 2110 1000 00 000 000000	48,513.29	3,425.90	0.00	0.00	17,612.52	30,900.77	63.70
Education Fund	10 E 2110 2110 00 000 000000	6,241.53	371.94	0.00	0.00	3,059.25	3,182.28	50.99
Education Fund	10 E 2110 2220 00 000 000000	13,210.31	926.28	0.00	0.00	4,967.18	8,243.13	62.40
Education Fund	10 E 2110 2230 00 000 000000	0.00	15.38	0.00	0.00	-44.74	44.74	0.00
Education Fund	10 E 2113 1100 00 300 000000	198,376.84	17,283.66	0.00	0.00	44,398.42	153,978.42	77.62
Education Fund	10 E 2113 2110 00 300 000000	26,601.19	2,182.32	0.00	0.00	9,420.65	17,180.54	64.59
Education Fund	10 E 2113 2220 00 300 000000	45,755.58	4,337.76	0.00	-12.52	8,537.66	37,230.44	81.37
Education Fund	10 E 2113 2230 00 300 000000	0.00	95.02	0.00	0.00	-286.46	286.46	0.00
Education Fund	10 E 2113 3000 00 300 000000	0.00	0.00	0.00	0.00	0.00	0.00	0.00
Education Fund	10 E 2113 3000 00 302 000000	0.00	0.00	0.00	0.00	0.00	0.00	0.00
Education Fund	10 E 2113 3320 00 300 000000	0.00	0.00	0.00	0.00	0.00	0.00	0.00
Education Fund	10 E 2113 3320 00 302 000000	0.00	0.00	0.00	0.00	0.00	0.00	0.00
Education Fund	10 E 2113 4100 00 300 000000	1,300.00	0.00	0.00	0.00	1,273.37	26.63	2.05
Education Fund	10 E 2113 4100 00 300 000001	0.00	0.00	0.00	0.00	0.00	0.00	0.00
Education Fund	10 E 2113 4100 00 300 000002	1,300.00	0.00	0.00	0.00	1,300.00	0.00	0.00
Education Fund	10 E 2113 4100 00 302 000000	0.00	0.00	0.00	0.00	0.00	0.00	0.00
Education Fund	10 E 2113 4100 00 302 000001	0.00	0.00	0.00	0.00	0.00	0.00	0.00
Education Fund	10 E 2113 4100 00 302 000002	0.00	0.00	0.00	0.00	0.00	0.00	0.00
Education Fund	10 E 2113 4700 00 300 000000	0.00	0.00	0.00	0.00	0.00	0.00	0.00
Education Fund	10 E 2113 4700 00 302 000000	0.00	0.00	0.00	0.00	0.00	0.00	0.00
Education Fund	10 E 2113 6400 00 300 000000	0.00	0.00	0.00	0.00	0.00	0.00	0.00
Education Fund	10 E 2113 6400 00 302 000000	0.00	0.00	0.00	0.00	0.00	0.00	0.00
Education Fund	10 E 2120 1100 00 300 000000	509,454.32	44,810.78	0.00	0.00	120,286.62	389,167.70	76.39
Education Fund	10 E 2120 2110 00 300 000000	66,344.62	5,658.02	0.00	0.00	22,793.57	43,551.05	65.64
Education Fund	10 E 2120 2220 00 300 000000	108,647.62	9,704.84	0.00	-24.52	24,734.04	83,938.10	77.26
Education Fund	10 E 2120 2230 00 300 000000	0.00	220.80	0.00	0.00	-662.40	662.40	0.00
Education Fund	10 E 2120 3140 00 300 000000	1,606.80	0.00	0.00	0.00	1,506.80	100.00	6.22
Education Fund	10 E 2120 3140 00 300 000001	0.00	0.00	0.00	0.00	0.00	0.00	0.00
Education Fund	10 E 2120 3140 00 302 000000	0.00	0.00	0.00	0.00	0.00	0.00	0.00
Education Fund	10 E 2120 3140 00 302 000001	0.00	0.00	0.00	0.00	0.00	0.00	0.00
Education Fund	10 E 2120 4100 00 300 000000	0.00	0.00	0.00	0.00	0.00	0.00	0.00
Education Fund	10 E 2120 4100 00 300 000001	500.00	0.00	0.00	0.00	4.90	495.10	99.02

Expenditure Report

Fiscal Year: 2020-2021
Month: March

COUNTY OF GRUNDY SCHOOL DIST 111

Fund Description	Account Number	Revised Budget	MTD Activity	Encumbrance	Pending Activity	Available Funds	Year to Date Activity	Percent of Budget Used
Education Fund	10 E 2120 4100 00 300 000002	500.00	0.00	0.00	0.00	500.00	0.00	0.00
Education Fund	10 E 2120 4100 00 301 000000	0.00	0.00	0.00	0.00	0.00	0.00	0.00
Education Fund	10 E 2120 4100 00 302 000000	0.00	0.00	0.00	0.00	0.00	0.00	0.00
Education Fund	10 E 2120 4100 00 302 000001	0.00	0.00	0.00	0.00	0.00	0.00	0.00
Education Fund	10 E 2120 4100 00 302 000002	0.00	0.00	0.00	0.00	0.00	0.00	0.00
Education Fund	10 E 2120 4200 00 300 000000	0.00	0.00	0.00	0.00	0.00	0.00	0.00
Education Fund	10 E 2120 4200 00 302 000000	0.00	0.00	0.00	0.00	0.00	0.00	0.00
Education Fund	10 E 2120 5400 00 300 000000	0.00	0.00	0.00	0.00	0.00	0.00	0.00
Education Fund	10 E 2120 5400 00 302 000000	0.00	0.00	0.00	0.00	0.00	0.00	0.00
Education Fund	10 E 2120 6400 00 300 000000	0.00	0.00	0.00	0.00	0.00	0.00	0.00
Education Fund	10 E 2120 6400 00 300 000001	500.00	0.00	0.00	0.00	500.00	0.00	0.00
Education Fund	10 E 2120 6400 00 302 000000	0.00	0.00	0.00	0.00	0.00	0.00	0.00
Education Fund	10 E 2120 6400 00 302 000001	0.00	0.00	0.00	0.00	-357.00	357.00	0.00
Education Fund	10 E 2125 1100 00 300 000000	78,739.82	6,687.84	0.00	0.00	18,549.26	60,190.56	76.44
Education Fund	10 E 2125 1100 00 300 000001	35,653.37	3,942.40	0.00	0.00	844.48	34,808.89	97.63
Education Fund	10 E 2125 1100 00 302 000000	41,143.41	3,370.26	0.00	0.00	9,820.73	31,322.68	76.13
Education Fund	10 E 2125 2110 00 300 000000	0.00	0.00	0.00	0.00	0.00	0.00	0.00
Education Fund	10 E 2125 2220 00 300 000000	1,172.77	13.06	0.00	-4.52	581.89	595.40	50.77
Education Fund	10 E 2125 2220 00 300 000001	0.00	696.94	0.00	0.00	-2,725.56	2,725.56	0.00
Education Fund	10 E 2125 2220 00 302 000000	23,954.57	2,217.02	0.00	0.00	5,137.49	18,817.08	78.55
Education Fund	10 E 2125 2230 00 300 000000	0.00	36.80	0.00	0.00	-110.40	110.40	0.00
Education Fund	10 E 2125 2230 00 302 000000	0.00	36.80	0.00	0.00	-110.40	110.40	0.00
Education Fund	10 E 2125 3000 00 300 000000	0.00	0.00	0.00	0.00	0.00	0.00	0.00
Education Fund	10 E 2125 3000 00 300 000001	0.00	0.00	0.00	0.00	0.00	0.00	0.00
Education Fund	10 E 2125 3000 00 302 000000	8,347.42	387.45	0.00	387.45	1,271.82	6,688.15	80.12
Education Fund	10 E 2125 3000 00 302 000001	0.00	175.00	0.00	0.00	-240.00	240.00	0.00
Education Fund	10 E 2125 3230 00 300 000000	0.00	0.00	0.00	0.00	0.00	0.00	0.00
Education Fund	10 E 2125 3230 00 300 000001	0.00	0.00	0.00	0.00	0.00	0.00	0.00
Education Fund	10 E 2125 3230 00 302 000000	0.00	0.00	0.00	0.00	0.00	0.00	0.00
Education Fund	10 E 2125 3230 00 302 000001	0.00	0.00	0.00	0.00	0.00	0.00	0.00
Education Fund	10 E 2125 4100 00 300 000000	0.00	0.00	0.00	0.00	0.00	0.00	0.00
Education Fund	10 E 2125 4100 00 300 000001	0.00	0.00	0.00	0.00	0.00	0.00	0.00
Education Fund	10 E 2125 4100 00 300 000002	1,500.00	59.92	0.00	0.00	506.52	993.48	66.23

Expenditure Report

Fiscal Year: 2020-2021
Month: March

COUNTY OF GRUNDY SCHOOL DIST 111

Fund Description	Account Number	Revised Budget	MTD Activity	Encumbrance	Pending Activity	Available Funds	Year to Date Activity	Percent of Budget Used
Education Fund	10 E 2125 4100 00 300 000003	0.00	0.00	0.00	0.00	0.00	0.00	0.00
Education Fund	10 E 2125 4100 00 302 000000	0.00	0.00	0.00	0.00	0.00	0.00	0.00
Education Fund	10 E 2125 4100 00 302 000001	0.00	0.00	0.00	0.00	0.00	0.00	0.00
Education Fund	10 E 2125 4100 00 302 000002	0.00	0.00	0.00	0.00	0.00	0.00	0.00
Education Fund	10 E 2125 5400 00 300 000000	0.00	0.00	0.00	0.00	0.00	0.00	0.00
Education Fund	10 E 2125 5400 00 300 000001	0.00	0.00	0.00	0.00	0.00	0.00	0.00
Education Fund	10 E 2125 5400 00 302 000000	0.00	0.00	0.00	0.00	0.00	0.00	0.00
Education Fund	10 E 2125 5400 00 302 000001	0.00	0.00	0.00	0.00	0.00	0.00	0.00
Education Fund	10 E 2134 1100 00 300 000000	42,204.85	5,574.03	0.00	0.00	9,610.52	32,594.33	77.23
Education Fund	10 E 2134 1100 00 302 000000	39,370.04	4,383.33	0.00	0.00	11,456.47	27,913.57	70.90
Education Fund	10 E 2134 2110 00 300 000000	0.00	0.00	0.00	0.00	0.00	0.00	0.00
Education Fund	10 E 2134 2110 00 302 000000	0.00	0.00	0.00	0.00	0.00	0.00	0.00
Education Fund	10 E 2134 2220 00 300 000000	425.47	3.80	0.00	-4.52	377.55	52.44	12.33
Education Fund	10 E 2134 2220 00 302 000000	3,560.89	3.80	0.00	0.00	3,549.49	11.40	0.32
Education Fund	10 E 2134 3000 00 300 000000	500.00	18.36	0.00	0.00	229.27	270.73	54.15
Education Fund	10 E 2134 3000 00 302 000000	0.00	0.00	0.00	0.00	0.00	0.00	0.00
Education Fund	10 E 2134 3230 00 300 000000	0.00	0.00	0.00	0.00	0.00	0.00	0.00
Education Fund	10 E 2134 3230 00 302 000000	0.00	0.00	0.00	0.00	0.00	0.00	0.00
Education Fund	10 E 2134 4100 00 300 000000	8,000.00	0.00	0.00	0.00	6,829.69	1,170.31	14.63
Education Fund	10 E 2134 4100 00 300 000001	0.00	0.00	0.00	0.00	0.00	0.00	0.00
Education Fund	10 E 2134 4100 00 300 000002	0.00	0.00	0.00	0.00	0.00	0.00	0.00
Education Fund	10 E 2134 4100 00 302 000000	0.00	0.00	0.00	0.00	0.00	0.00	0.00
Education Fund	10 E 2134 4100 00 302 000001	0.00	0.00	0.00	0.00	0.00	0.00	0.00
Education Fund	10 E 2134 4100 00 302 000002	0.00	0.00	0.00	0.00	0.00	0.00	0.00
Education Fund	10 E 2134 4200 00 300 000000	0.00	0.00	0.00	0.00	0.00	0.00	0.00
Education Fund	10 E 2134 4200 00 302 000000	0.00	0.00	0.00	0.00	0.00	0.00	0.00
Education Fund	10 E 2134 5400 00 300 000000	500.00	0.00	0.00	0.00	-171.96	671.96	134.39
Education Fund	10 E 2134 5400 00 302 000000	0.00	0.00	0.00	0.00	0.00	0.00	0.00
Education Fund	10 E 2140 1100 00 000 000000	135,805.92	11,873.84	0.00	0.00	25,652.47	110,153.45	81.11
Education Fund	10 E 2140 2110 00 000 000000	18,467.34	1,499.28	0.00	0.00	6,042.84	12,424.50	67.28
Education Fund	10 E 2140 2220 00 000 000000	49.92	8.00	0.00	-4.52	-10.60	65.04	130.29
Education Fund	10 E 2140 4000 00 300 000000	750.00	0.00	0.00	0.00	731.02	18.98	2.53
Education Fund	10 E 2142 3000 00 000 000000	0.00	0.00	0.00	0.00	0.00	0.00	0.00

Expenditure Report

Fiscal Year: 2020-2021
Month: March

COUNTY OF GRUNDY SCHOOL DIST 111

Fund Description	Account Number	Revised Budget	MTD Activity	Encumbrance	Pending Activity	Available Funds	Year to Date Activity	Percent of Budget Used
Education Fund	10 E 2190 2120 00 300 000000	1,829.13	0.00	0.00	0.00	1,829.13	0.00	0.00
Education Fund	10 E 2210 1100 00 300 000000	106,399.25	7,301.92	0.00	0.00	32,858.57	73,540.68	69.12
Education Fund	10 E 2210 1100 00 300 000001	0.00	0.00	0.00	0.00	0.00	0.00	0.00
Education Fund	10 E 2210 1100 00 300 000002	0.00	0.00	0.00	0.00	0.00	0.00	0.00
Education Fund	10 E 2210 1100 00 300 000073	0.00	0.00	0.00	0.00	-8,000.00	8,000.00	0.00
Education Fund	10 E 2210 1100 00 302 000000	61,449.42	2,796.62	0.00	0.00	36,004.48	25,444.94	41.41
Education Fund	10 E 2210 2110 00 300 000000	13,726.34	942.06	0.00	0.00	2,578.59	11,147.75	81.21
Education Fund	10 E 2210 2110 00 300 000001	0.00	0.00	0.00	0.00	0.00	0.00	0.00
Education Fund	10 E 2210 2210 00 300 000000	0.00	0.00	0.00	0.00	0.00	0.00	0.00
Education Fund	10 E 2210 2220 00 300 000000	23,513.30	2,085.16	0.00	-5.08	5,570.93	17,947.45	76.33
Education Fund	10 E 2210 2220 00 302 000000	162.08	1,412.48	0.00	-0.52	-8,918.36	9,080.96	5,602.76
Education Fund	10 E 2210 2230 00 300 000000	0.00	117.38	0.00	0.00	-352.14	352.14	0.00
Education Fund	10 E 2210 2230 00 302 000000	0.00	36.80	0.00	0.00	-110.40	110.40	0.00
Education Fund	10 E 2210 3000 00 000 000000	17,837.54	-140.67	0.00	0.00	-7,954.46	25,792.00	144.59
Education Fund	10 E 2210 3000 00 300 000000	10,000.00	0.00	0.00	0.00	10,000.00	0.00	0.00
Education Fund	10 E 2210 3000 00 300 000001	0.00	0.00	0.00	0.00	0.00	0.00	0.00
Education Fund	10 E 2210 3000 00 300 000002	0.00	0.00	0.00	0.00	-1,678.88	1,678.88	0.00
Education Fund	10 E 2210 3000 00 300 000003	0.00	0.00	0.00	0.00	0.00	0.00	0.00
Education Fund	10 E 2210 3000 00 300 000004	0.00	0.00	0.00	0.00	0.00	0.00	0.00
Education Fund	10 E 2210 3000 00 300 000005	0.00	0.00	0.00	0.00	0.00	0.00	0.00
Education Fund	10 E 2210 3000 00 300 000006	90,000.00	90.00	0.00	0.00	89,910.00	90.00	0.10
Education Fund	10 E 2210 3000 00 300 000007	10,500.00	0.00	0.00	0.00	10,500.00	0.00	0.00
Education Fund	10 E 2210 3000 05 300 000000	3,800.00	0.00	0.00	0.00	3,800.00	0.00	0.00
Education Fund	10 E 2210 3000 06 300 000000	3,800.00	0.00	0.00	0.00	3,800.00	0.00	0.00
Education Fund	10 E 2210 3000 10 300 000000	3,800.00	0.00	0.00	0.00	3,192.30	607.70	15.99
Education Fund	10 E 2210 3000 11 300 000000	3,800.00	0.00	0.00	0.00	3,800.00	0.00	0.00
Education Fund	10 E 2210 3000 13 300 000000	3,800.00	0.00	0.00	0.00	3,800.00	0.00	0.00
Education Fund	10 E 2210 3000 15 300 000000	3,800.00	1,425.00	765.00	0.00	594.00	2,441.00	64.24
Education Fund	10 E 2210 3000 50 300 000000	3,800.00	0.00	0.00	0.00	3,800.00	0.00	0.00
Education Fund	10 E 2210 3120 00 300 000000	17,000.00	605.67	300.00	-300.00	10,693.73	6,306.27	37.10
Education Fund	10 E 2210 4000 00 000 000000	7,000.00	0.00	0.00	0.00	7,000.00	0.00	0.00
Education Fund	10 E 2210 4000 00 300 000000	0.00	0.00	0.00	0.00	-34,951.19	34,951.19	0.00
Education Fund	10 E 2210 4000 00 300 000001	0.00	449.94	78.89	0.00	-1,622.03	1,543.14	0.00

Expenditure Report

Fiscal Year: 2020-2021
Month: March

COUNTY OF GRUNDY SCHOOL DIST 111

Fund Description	Account Number	Revised Budget	MTD Activity	Encumbrance	Pending Activity	Available Funds	Year to Date Activity	Percent of Budget Used
Education Fund	10 E 2210 6400 00 300 000000	500.00	0.00	0.00	0.00	500.00	0.00	0.00
Education Fund	10 E 2210 6400 00 300 000001	500.00	0.00	0.00	0.00	300.00	200.00	40.00
Education Fund	10 E 2212 2110 00 300 000000	0.00	0.00	0.00	0.00	0.00	0.00	0.00
Education Fund	10 E 2213 2110 00 300 000000	0.00	0.00	0.00	0.00	0.00	0.00	0.00
Education Fund	10 E 2220 0000 00 000 000000	0.00	0.00	0.00	0.00	0.00	0.00	0.00
Education Fund	10 E 2220 1100 00 300 000000	0.00	0.00	0.00	0.00	0.00	0.00	0.00
Education Fund	10 E 2220 4000 00 300 000000	0.00	0.00	0.00	0.00	0.00	0.00	0.00
Education Fund	10 E 2222 1100 00 300 000000	50,214.68	4,189.90	0.00	0.00	13,506.23	36,708.45	73.10
Education Fund	10 E 2222 1100 00 300 000001	62,549.20	4,103.84	0.00	0.00	25,083.84	37,465.36	59.90
Education Fund	10 E 2222 1100 00 302 000000	25,726.27	2,152.70	0.00	0.00	6,400.44	19,325.83	75.12
Education Fund	10 E 2222 2110 00 300 000000	0.00	0.00	0.00	0.00	0.00	0.00	0.00
Education Fund	10 E 2222 2110 00 300 000001	6,817.36	518.14	0.00	0.00	2,825.31	3,992.05	58.56
Education Fund	10 E 2222 2110 00 302 000000	0.00	0.00	0.00	0.00	0.00	0.00	0.00
Education Fund	10 E 2222 2220 00 300 000000	10,366.52	2,203.96	0.00	-0.52	1,473.29	8,893.75	85.79
Education Fund	10 E 2222 2220 00 300 000001	0.00	710.00	0.00	0.00	-5,977.20	5,977.20	0.00
Education Fund	10 E 2222 2220 00 302 000000	0.00	2,203.96	0.00	0.00	-8,619.12	8,619.12	0.00
Education Fund	10 E 2222 2230 00 300 000001	0.00	36.80	0.00	0.00	-110.40	110.40	0.00
Education Fund	10 E 2222 3000 00 300 000000	0.00	0.00	0.00	0.00	0.00	0.00	0.00
Education Fund	10 E 2222 3000 00 302 000000	0.00	0.00	0.00	0.00	0.00	0.00	0.00
Education Fund	10 E 2222 4100 00 300 000000	7,800.14	0.00	1,647.83	0.00	4,662.07	1,490.24	19.11
Education Fund	10 E 2222 4100 00 300 000001	0.00	0.00	0.00	0.00	0.00	0.00	0.00
Education Fund	10 E 2222 4100 00 302 000000	0.00	0.00	0.00	0.00	0.00	0.00	0.00
Education Fund	10 E 2222 4100 00 302 000001	0.00	0.00	0.00	0.00	0.00	0.00	0.00
Education Fund	10 E 2222 4300 00 300 000000	20,000.00	0.00	2,235.31	785.58	711.64	16,267.47	81.34
Education Fund	10 E 2222 4300 00 300 000001	2,050.00	0.00	0.00	0.00	2,050.00	0.00	0.00
Education Fund	10 E 2222 4300 00 302 000000	0.00	0.00	0.00	0.00	0.00	0.00	0.00
Education Fund	10 E 2222 4400 00 300 000000	60,134.86	0.00	9,773.47	0.00	0.00	50,361.39	83.75
Education Fund	10 E 2222 4400 00 302 000000	0.00	0.00	0.00	0.00	0.00	0.00	0.00
Education Fund	10 E 2222 5400 00 300 000000	0.00	0.00	0.00	0.00	0.00	0.00	0.00
Education Fund	10 E 2222 5400 00 302 000000	0.00	0.00	0.00	0.00	0.00	0.00	0.00
Education Fund	10 E 2222 6400 00 300 000000	0.00	0.00	0.00	0.00	0.00	0.00	0.00
Education Fund	10 E 2222 6400 00 302 000000	0.00	0.00	0.00	0.00	0.00	0.00	0.00
Education Fund	10 E 2225 1100 00 300 000000	85,995.00	7,235.16	0.00	0.00	20,878.56	65,116.44	75.72

Expenditure Report

Fiscal Year: 2020-2021
Month: March

COUNTY OF GRUNDY SCHOOL DIST 111

Fund Description	Account Number	Revised Budget	MTD Activity	Encumbrance	Pending Activity	Available Funds	Year to Date Activity	Percent of Budget Used
Education Fund	10 E 2225 1100 00 300 000001	125,000.00	5,668.64	0.00	0.00	73,835.09	51,164.91	40.93
Education Fund	10 E 2225 1100 00 300 000002	0.00	0.00	0.00	0.00	0.00	0.00	0.00
Education Fund	10 E 2225 1100 00 302 000000	0.00	1,836.30	0.00	0.00	-8,263.35	8,263.35	0.00
Education Fund	10 E 2225 1200 00 300 000000	7,000.00	0.00	0.00	0.00	-6,607.50	13,607.50	194.39
Education Fund	10 E 2225 2110 00 300 000000	0.00	0.00	0.00	0.00	0.00	0.00	0.00
Education Fund	10 E 2225 2110 00 302 000000	0.00	0.00	0.00	0.00	0.00	0.00	0.00
Education Fund	10 E 2225 2220 00 300 000000	50,303.24	896.24	0.00	-12.52	37,414.16	12,901.60	25.65
Education Fund	10 E 2225 2220 00 300 000001	0.00	2,333.02	0.00	0.00	-19,805.49	19,805.49	0.00
Education Fund	10 E 2225 2220 00 302 000000	0.00	710.00	0.00	0.00	-3,399.48	3,399.48	0.00
Education Fund	10 E 2225 2230 00 300 000000	0.00	36.80	0.00	0.00	-110.40	110.40	0.00
Education Fund	10 E 2225 2230 00 300 000001	0.00	36.80	0.00	0.00	-110.40	110.40	0.00
Education Fund	10 E 2225 2230 00 302 000000	0.00	36.80	0.00	0.00	-110.40	110.40	0.00
Education Fund	10 E 2225 3000 00 300 000000	13,000.00	751.97	0.00	0.00	358.63	12,641.37	97.24
Education Fund	10 E 2225 3000 00 300 000001	54,000.00	88.40	0.00	5,094.06	10,415.36	38,490.58	2671.28
Education Fund	10 E 2225 3000 00 300 000002	0.00	0.00	0.00	0.00	0.00	0.00	0.00
Education Fund	10 E 2225 3900 00 300 000000	44,000.00	0.00	0.00	0.00	17,835.06	26,164.94	59.47
Education Fund	10 E 2225 4000 00 300 000000	0.00	0.00	0.00	0.00	0.00	0.00	0.00
Education Fund	10 E 2225 4100 00 300 000000	32,000.00	843.77	5,544.49	-139.63	4,971.64	21,623.50	67.57
Education Fund	10 E 2225 4100 00 300 000001	0.00	0.00	0.00	0.00	0.00	0.00	0.00
Education Fund	10 E 2225 4200 00 300 000000	0.00	0.00	0.00	0.00	0.00	0.00	0.00
Education Fund	10 E 2225 4700 00 300 000000	125,000.00	5,358.98	232.00	-652.97	18,759.18	106,661.79	85.33
Education Fund	10 E 2225 5400 00 300 000000	50,000.00	0.00	442.48	0.00	-304,016.73	353,574.25	707.15
Education Fund	10 E 2225 5400 00 300 000001	375,000.00	0.00	0.00	0.00	284,917.92	90,082.08	24.02
Education Fund	10 E 2225 5400 00 300 000002	0.00	0.00	0.00	0.00	0.00	0.00	0.00
Education Fund	10 E 2225 5400 00 300 000003	0.00	0.00	0.00	0.00	0.00	0.00	0.00
Education Fund	10 E 2225 6400 00 300 000000	0.00	0.00	0.00	0.00	0.00	0.00	0.00
Education Fund	10 E 2225 7100 00 300 000000	0.00	0.00	0.00	0.00	0.00	0.00	0.00
Education Fund	10 E 2230 0000 00 000 000000	0.00	0.00	0.00	0.00	0.00	0.00	0.00
Education Fund	10 E 2230 3000 00 300 000000	0.00	0.00	0.00	0.00	0.00	0.00	0.00
Education Fund	10 E 2230 4000 00 300 000000	1,500.00	0.00	0.00	0.00	-92.25	1,592.25	106.15
Education Fund	10 E 2300 1000 00 000 000000	0.00	0.00	0.00	0.00	0.00	0.00	0.00
Education Fund	10 E 2300 1200 00 000 000000	2,300.00	0.00	0.00	0.00	-40.83	2,340.83	101.78
Education Fund	10 E 2300 2110 00 000 000000	300.00	0.00	0.00	0.00	73.48	226.52	75.51

Expenditure Report

Fiscal Year: 2020-2021
Month: March

COUNTY OF GRUNDY SCHOOL DIST 111

Fund Description	Account Number	Revised Budget	MTD Activity	Encumbrance	Pending Activity	Available Funds	Year to Date Activity	Percent of Budget Used
Education Fund	10 E 2300 2220 00 000 000000	0.00	0.00	0.00	0.00	0.00	0.00	0.00
Education Fund	10 E 2300 5000 00 300 000000	0.00	0.00	0.00	0.00	0.00	0.00	0.00
Education Fund	10 E 2310 2000 00 300 000000	0.00	0.00	0.00	0.00	0.00	0.00	0.00
Education Fund	10 E 2310 2110 00 300 000000	3,600.00	0.00	0.00	0.00	3,600.00	0.00	0.00
Education Fund	10 E 2310 2220 00 300 000000	3,500.00	0.00	0.00	0.00	3,500.00	0.00	0.00
Education Fund	10 E 2310 3000 00 000 000000	0.00	0.00	0.00	0.00	0.00	0.00	0.00
Education Fund	10 E 2310 3000 00 300 000000	40,000.00	8,040.00	0.00	540.00	-8,315.50	47,775.50	119.44
Education Fund	10 E 2310 3000 00 300 000001	0.00	0.00	0.00	0.00	0.00	0.00	0.00
Education Fund	10 E 2310 3100 00 300 000000	0.00	0.00	0.00	0.00	0.00	0.00	0.00
Education Fund	10 E 2310 3110 00 300 000000	5,000.00	0.00	0.00	0.00	4,316.20	683.80	13.68
Education Fund	10 E 2310 3110 00 300 000001	5,000.00	0.00	0.00	0.00	149.00	4,851.00	97.02
Education Fund	10 E 2310 3150 00 300 000000	35,000.00	1,135.60	0.00	0.00	9,478.98	25,521.02	72.92
Education Fund	10 E 2310 3170 00 300 000000	12,000.00	0.00	0.00	0.00	1,500.00	10,500.00	87.50
Education Fund	10 E 2310 3180 00 300 000000	0.00	0.00	0.00	0.00	0.00	0.00	0.00
Education Fund	10 E 2310 3180 00 300 000001	0.00	0.00	0.00	0.00	0.00	0.00	0.00
Education Fund	10 E 2310 3190 00 300 000000	0.00	0.00	0.00	0.00	0.00	0.00	0.00
Education Fund	10 E 2310 3800 00 300 000000	0.00	0.00	0.00	0.00	0.00	0.00	0.00
Education Fund	10 E 2310 3800 00 300 000001	0.00	0.00	0.00	0.00	0.00	0.00	0.00
Education Fund	10 E 2310 3800 00 300 000002	15,000.00	0.00	0.00	0.00	4,057.00	10,943.00	72.95
Education Fund	10 E 2310 3900 00 300 000000	0.00	0.00	0.00	0.00	0.00	0.00	0.00
Education Fund	10 E 2310 4000 00 000 000000	0.00	0.00	0.00	0.00	0.00	0.00	0.00
Education Fund	10 E 2310 4100 00 300 000000	30,000.00	214.25	0.00	106.68	19,434.38	10,458.94	34.86
Education Fund	10 E 2310 4100 00 300 000001	0.00	0.00	0.00	0.00	0.00	0.00	0.00
Education Fund	10 E 2310 5400 00 300 000000	0.00	0.00	0.00	0.00	0.00	0.00	0.00
Education Fund	10 E 2310 6400 00 300 000000	17,000.00	257.50	0.00	0.00	16,742.50	257.50	1.51
Education Fund	10 E 2310 6400 00 300 000001	15,000.00	40.00	0.00	0.00	-3,537.16	18,537.16	123.58
Education Fund	10 E 2312 1100 00 300 000000	2,500.00	0.00	0.00	0.00	2,500.00	0.00	0.00
Education Fund	10 E 2313 1100 00 300 000000	0.00	0.00	0.00	0.00	0.00	0.00	0.00
Education Fund	10 E 2313 2110 00 300 000000	0.00	0.00	0.00	0.00	0.00	0.00	0.00
Education Fund	10 E 2313 2160 00 300 000000	0.00	0.00	0.00	0.00	0.00	0.00	0.00
Education Fund	10 E 2321 1100 00 300 000000	72,234.99	6,019.60	0.00	0.00	15,829.23	56,405.76	78.09
Education Fund	10 E 2321 1100 00 300 000001	195,590.40	16,299.20	0.00	0.00	48,897.60	146,692.80	75.00
Education Fund	10 E 2321 1100 00 300 000002	0.00	0.00	0.00	0.00	0.00	0.00	0.00

268

Expenditure Report

Fiscal Year: 2020-2021
Month: March

COUNTY OF GRUNDY SCHOOL DIST 111

Fund Description	Account Number	Revised Budget	MTD Activity	Encumbrance	Pending Activity	Available Funds	Year to Date Activity	Percent of Budget Used
Education Fund	10 E 2321 1100 00 300 000003	0.00	0.00	0.00	0.00	0.00	0.00	0.00
Education Fund	10 E 2321 2110 00 300 000000	27,769.80	0.00	0.00	0.00	27,769.80	0.00	0.00
Education Fund	10 E 2321 2110 00 300 000001	0.00	2,102.78	0.00	0.00	-19,448.59	19,448.59	0.00
Education Fund	10 E 2321 2160 00 300 000000	0.00	0.00	0.00	0.00	0.00	0.00	0.00
Education Fund	10 E 2321 2210 00 300 000000	0.00	0.00	0.00	0.00	0.00	0.00	0.00
Education Fund	10 E 2321 2220 00 300 000000	8,662.15	13.06	0.00	-12.20	8,538.99	135.36	1.56
Education Fund	10 E 2321 2220 00 300 000001	592.02	721.68	0.00	-0.52	-5,694.33	6,286.87	1,061.94
Education Fund	10 E 2321 2230 00 300 000000	0.00	36.80	0.00	0.00	-110.40	110.40	0.00
Education Fund	10 E 2321 2230 00 300 000001	0.00	36.80	0.00	0.00	-110.40	110.40	0.00
Education Fund	10 E 2321 3000 00 300 000000	0.00	0.00	0.00	0.00	0.00	0.00	0.00
Education Fund	10 E 2321 3100 00 300 000000	0.00	0.00	0.00	0.00	0.00	0.00	0.00
Education Fund	10 E 2321 3230 00 300 000000	0.00	0.00	0.00	0.00	0.00	0.00	0.00
Education Fund	10 E 2321 3320 00 300 000000	0.00	0.00	0.00	0.00	0.00	0.00	0.00
Education Fund	10 E 2321 3320 00 300 000001	1,500.00	43.68	0.00	57.68	1,052.10	390.22	26.01
Education Fund	10 E 2321 4100 00 300 000000	0.00	0.00	0.00	0.00	-267.59	267.59	0.00
Education Fund	10 E 2321 5400 00 300 000000	0.00	0.00	0.00	0.00	0.00	0.00	0.00
Education Fund	10 E 2321 6400 00 300 000000	2,000.00	0.00	0.00	0.00	1,440.00	560.00	28.00
Education Fund	10 E 2321 6400 00 300 000001	0.00	0.00	0.00	0.00	0.00	0.00	0.00
Education Fund	10 E 2321 6400 00 300 000002	0.00	0.00	0.00	0.00	0.00	0.00	0.00
Education Fund	10 E 2330 4000 00 300 000000	0.00	0.00	0.00	0.00	0.00	0.00	0.00
Education Fund	10 E 2410 1100 00 300 000000	39,322.31	3,269.50	0.00	0.00	9,539.68	29,782.63	75.74
Education Fund	10 E 2410 1100 00 300 000001	139,725.00	11,643.76	0.00	0.00	34,931.16	104,793.84	75.00
Education Fund	10 E 2410 1100 00 300 000002	50,931.26	4,347.46	0.00	0.00	11,804.12	39,127.14	76.82
Education Fund	10 E 2410 1100 00 300 000003	107,061.25	8,954.38	0.00	0.00	26,926.14	80,135.11	74.85
Education Fund	10 E 2410 1100 00 300 000004	331,844.00	25,952.58	0.00	0.00	93,396.84	238,447.16	71.86
Education Fund	10 E 2410 1100 00 302 000000	106,669.68	8,926.88	0.00	0.00	26,780.58	79,889.10	74.89
Education Fund	10 E 2410 1100 00 302 000001	0.00	0.00	0.00	0.00	0.00	0.00	0.00
Education Fund	10 E 2410 2110 00 300 000000	0.00	0.00	0.00	0.00	0.00	0.00	0.00
Education Fund	10 E 2410 2110 00 300 000001	75,199.49	1,502.18	0.00	0.00	61,483.39	13,716.10	18.24
Education Fund	10 E 2410 2110 00 300 000003	0.00	1,155.22	0.00	0.00	-9,088.94	9,088.94	0.00
Education Fund	10 E 2410 2110 00 300 000004	0.00	3,276.86	0.00	0.00	-26,301.34	26,301.34	0.00
Education Fund	10 E 2410 2110 00 302 000000	14,159.45	1,151.68	0.00	0.00	5,098.33	9,061.12	63.99
Education Fund	10 E 2410 2210 00 300 000000	0.00	0.00	0.00	0.00	0.00	0.00	0.00

Expenditure Report

Fiscal Year: 2020-2021
Month: March

COUNTY OF GRUNDY SCHOOL DIST 111

Fund Description	Account Number	Revised Budget	MTD Activity	Encumbrance	Pending Activity	Available Funds	Year to Date Activity	Percent of Budget Used
Education Fund	10 E 2410 2210 00 302 000000	0.00	0.00	0.00	0.00	0.00	0.00	0.00
Education Fund	10 E 2410 2220 00 300 000000	93,203.86	746.68	0.00	-4.52	85,735.14	7,473.24	8.02
Education Fund	10 E 2410 2220 00 300 000001	2,021.15	2,234.62	0.00	-7.72	-17,666.49	19,695.36	974.46
Education Fund	10 E 2410 2220 00 300 000002	2,457.26	1,514.16	0.00	-13.72	-11,538.67	14,009.65	570.13
Education Fund	10 E 2410 2220 00 300 000003	0.00	2,348.06	0.00	0.00	-19,850.61	19,850.61	0.00
Education Fund	10 E 2410 2220 00 300 000004	0.00	3,840.56	0.00	0.00	-33,146.76	33,146.76	0.00
Education Fund	10 E 2410 2220 00 302 000000	24,462.51	2,231.98	0.00	0.00	5,600.55	18,861.96	77.11
Education Fund	10 E 2410 2230 00 300 000000	0.00	36.80	0.00	0.00	-110.40	110.40	0.00
Education Fund	10 E 2410 2230 00 300 000001	0.00	117.38	0.00	0.00	-352.14	352.14	0.00
Education Fund	10 E 2410 2230 00 300 000002	0.00	36.80	0.00	0.00	-110.40	110.40	0.00
Education Fund	10 E 2410 2230 00 300 000003	0.00	117.38	0.00	0.00	-352.14	352.14	0.00
Education Fund	10 E 2410 2230 00 300 000004	0.00	96.60	0.00	0.00	-289.80	289.80	0.00
Education Fund	10 E 2410 2230 00 302 000000	0.00	117.38	0.00	0.00	-352.14	352.14	0.00
Education Fund	10 E 2410 3000 00 300 000000	10,000.00	0.00	0.00	0.00	7,863.11	2,136.89	21.37
Education Fund	10 E 2410 3000 00 300 000001	13,000.00	0.00	1,575.00	0.00	11,425.00	0.00	0.00
Education Fund	10 E 2410 3000 00 302 000000	0.00	0.00	0.00	0.00	0.00	0.00	0.00
Education Fund	10 E 2410 3000 00 302 000001	0.00	0.00	0.00	0.00	0.00	0.00	0.00
Education Fund	10 E 2410 3400 00 300 000000	31,000.00	1,188.67	0.00	2,564.48	19,474.31	8,961.21	28.91
Education Fund	10 E 2410 4100 00 300 000000	9,000.00	0.00	0.00	0.00	-5,786.82	14,786.82	164.30
Education Fund	10 E 2410 4100 00 300 000001	15,000.00	149.99	0.00	-530.67	4,851.96	10,678.71	71.19
Education Fund	10 E 2410 4100 00 300 000002	15,000.00	118.26	0.00	2,635.64	1,409.31	10,955.05	73.03
Education Fund	10 E 2410 4100 00 300 000003	0.00	0.00	0.00	0.00	0.00	0.00	0.00
Education Fund	10 E 2410 4100 00 300 000004	0.00	0.00	0.00	0.00	0.00	0.00	0.00
Education Fund	10 E 2410 4100 00 300 000005	5,000.00	0.00	0.00	0.00	5,000.00	0.00	0.00
Education Fund	10 E 2410 4100 00 302 000000	8,000.00	0.00	0.00	0.00	7,636.00	364.00	4.55
Education Fund	10 E 2410 4100 00 302 000001	0.00	0.00	0.00	0.00	0.00	0.00	0.00
Education Fund	10 E 2410 4100 00 302 000002	0.00	0.00	0.00	0.00	0.00	0.00	0.00
Education Fund	10 E 2410 4100 00 302 000003	0.00	0.00	0.00	0.00	0.00	0.00	0.00
Education Fund	10 E 2410 5400 00 300 000000	0.00	0.00	0.00	0.00	0.00	0.00	0.00
Education Fund	10 E 2410 5400 00 300 000001	0.00	0.00	0.00	0.00	0.00	0.00	0.00
Education Fund	10 E 2410 5400 00 302 000000	0.00	0.00	0.00	0.00	0.00	0.00	0.00
Education Fund	10 E 2410 5400 00 302 000001	0.00	0.00	0.00	0.00	0.00	0.00	0.00
Education Fund	10 E 2410 6400 00 300 000000	2,500.00	0.00	0.00	0.00	1,452.00	1,048.00	41.92

Expenditure Report

Fiscal Year: 2020-2021
Month: March

COUNTY OF GRUNDY SCHOOL DIST 111

Fund Description	Account Number	Revised Budget	MTD Activity	Encumbrance	Pending Activity	Available Funds	Year to Date Activity	Percent of Budget Used
Education Fund	10 E 2410 6400 00 300 000001	500.00	0.00	0.00	0.00	101.00	399.00	79.80
Education Fund	10 E 2410 6400 00 300 000002	2,000.00	0.00	0.00	0.00	2,000.00	0.00	0.00
Education Fund	10 E 2410 6400 00 300 000003	500.00	0.00	0.00	0.00	500.00	0.00	0.00
Education Fund	10 E 2410 6400 00 300 000004	9,000.00	0.00	0.00	0.00	1,500.00	7,500.00	83.33
Education Fund	10 E 2410 6400 00 302 000000	0.00	0.00	0.00	0.00	0.00	0.00	0.00
Education Fund	10 E 2410 6400 00 302 000001	0.00	0.00	0.00	0.00	0.00	0.00	0.00
Education Fund	10 E 2410 6400 00 302 000002	0.00	0.00	0.00	0.00	0.00	0.00	0.00
Education Fund	10 E 2410 6400 00 302 000003	500.00	0.00	0.00	0.00	500.00	0.00	0.00
Education Fund	10 E 2490 1100 00 300 000000	69,001.24	5,148.42	0.00	0.00	24,978.80	44,022.44	63.80
Education Fund	10 E 2490 1100 00 300 000001	0.00	0.00	0.00	0.00	0.00	0.00	0.00
Education Fund	10 E 2490 2110 00 300 000000	0.00	0.00	0.00	0.00	-32.26	32.26	0.00
Education Fund	10 E 2490 2220 00 300 000000	42,263.19	4,704.90	0.00	-4.52	7,098.50	35,169.21	83.21
Education Fund	10 E 2490 2220 00 300 000001	1,940.35	0.00	0.00	-12.52	287.00	1,665.87	85.85
Education Fund	10 E 2490 2230 00 300 000000	0.00	72.44	0.00	0.00	-271.78	271.78	0.00
Education Fund	10 E 2490 3000 00 300 000000	1,000.00	0.00	0.00	0.00	1,000.00	0.00	0.00
Education Fund	10 E 2490 3000 00 302 000000	0.00	0.00	0.00	0.00	0.00	0.00	0.00
Education Fund	10 E 2490 4100 00 300 000000	4,000.00	0.00	0.00	0.00	2,131.01	1,868.99	46.72
Education Fund	10 E 2490 4100 00 300 000001	0.00	0.00	0.00	0.00	0.00	0.00	0.00
Education Fund	10 E 2490 4100 00 302 000000	0.00	0.00	0.00	0.00	0.00	0.00	0.00
Education Fund	10 E 2490 4100 00 302 000001	0.00	0.00	0.00	0.00	0.00	0.00	0.00
Education Fund	10 E 2490 5400 00 300 000000	0.00	0.00	0.00	0.00	0.00	0.00	0.00
Education Fund	10 E 2490 5400 00 302 000000	0.00	0.00	0.00	0.00	0.00	0.00	0.00
Education Fund	10 E 2490 6400 00 300 000000	0.00	0.00	0.00	0.00	0.00	0.00	0.00
Education Fund	10 E 2490 6400 00 300 000001	0.00	0.00	0.00	0.00	0.00	0.00	0.00
Education Fund	10 E 2490 6400 00 302 000000	0.00	0.00	0.00	0.00	0.00	0.00	0.00
Education Fund	10 E 2490 6400 00 302 000001	0.00	0.00	0.00	0.00	0.00	0.00	0.00
Education Fund	10 E 2510 1100 00 300 000000	56,009.69	4,667.46	0.00	0.00	14,002.55	42,007.14	75.00
Education Fund	10 E 2510 2110 00 300 000000	0.00	0.00	0.00	0.00	0.00	0.00	0.00
Education Fund	10 E 2510 2120 00 300 000000	3,658.63	0.00	0.00	0.00	3,658.63	0.00	0.00
Education Fund	10 E 2510 2210 00 300 000000	0.00	0.00	0.00	0.00	0.00	0.00	0.00
Education Fund	10 E 2510 2220 00 300 000000	8,274.00	745.76	0.00	-9.96	1,897.35	6,386.61	77.19
Education Fund	10 E 2510 2230 00 300 000000	0.00	39.14	0.00	0.00	-117.42	117.42	0.00
Education Fund	10 E 2510 3320 00 300 000000	2,000.00	0.00	0.00	0.00	2,000.00	0.00	0.00

271

Expenditure Report

Fiscal Year: 2020-2021
Month: March

COUNTY OF GRUNDY SCHOOL DIST 111

Fund Description	Account Number	Revised Budget	MTD Activity	Encumbrance	Pending Activity	Available Funds	Year to Date Activity	Percent of Budget Used
Education Fund	10 E 2510 6400 00 300 000000	4,000.00	855.00	0.00	0.00	2,870.00	1,130.00	28.25
Education Fund	10 E 2510 6400 00 300 000001	0.00	0.00	0.00	0.00	0.00	0.00	0.00
Education Fund	10 E 2525 1100 00 300 000000	153,078.80	8,308.34	0.00	0.00	77,322.51	75,756.29	49.49
Education Fund	10 E 2525 2220 00 300 000000	15,811.82	-902.66	0.00	-4.52	5,972.72	9,843.62	62.25
Education Fund	10 E 2525 2230 00 300 000000	0.00	69.92	0.00	0.00	-209.76	209.76	0.00
Education Fund	10 E 2525 3000 00 300 000000	70,000.00	0.00	0.00	120.00	64,046.00	5,834.00	8.33
Education Fund	10 E 2525 3230 00 300 000000	0.00	0.00	0.00	0.00	0.00	0.00	0.00
Education Fund	10 E 2525 3320 00 300 000000	400.00	0.00	0.00	0.00	343.65	56.35	14.09
Education Fund	10 E 2525 3910 00 300 000000	65,000.00	0.00	0.00	0.00	65,000.00	0.00	0.00
Education Fund	10 E 2525 4100 00 000 000000	0.00	0.00	0.00	0.00	0.00	0.00	0.00
Education Fund	10 E 2525 4100 00 300 000000	3,500.00	0.00	0.00	39.93	-436.94	3,897.01	111.34
Education Fund	10 E 2525 5400 00 300 000000	2,500.00	0.00	0.00	0.00	2,500.00	0.00	0.00
Education Fund	10 E 2525 6400 00 300 000000	500.00	0.00	0.00	0.00	500.00	0.00	0.00
Education Fund	10 E 2560 3000 00 300 000000	500,000.00	64,542.76	0.00	0.00	225,519.39	274,480.61	272.54.90
Education Fund	10 E 2560 3000 00 300 000001	0.00	0.00	0.00	0.00	0.00	0.00	0.00
Education Fund	10 E 2560 3000 00 302 000000	0.00	0.00	0.00	0.00	0.00	0.00	0.00
Education Fund	10 E 2560 3150 00 300 000000	35,000.00	1,521.40	0.00	210.58	24,009.62	10,779.80	30.80
Education Fund	10 E 2560 3150 00 302 000000	0.00	0.00	0.00	0.00	0.00	0.00	0.00
Education Fund	10 E 2560 3230 00 300 000000	0.00	0.00	0.00	0.00	0.00	0.00	0.00
Education Fund	10 E 2560 3230 00 302 000000	0.00	0.00	0.00	0.00	0.00	0.00	0.00
Education Fund	10 E 2560 4100 00 300 000000	4,000.00	0.00	0.00	0.00	4,000.00	0.00	0.00
Education Fund	10 E 2560 4100 00 300 000001	0.00	0.00	0.00	0.00	0.00	0.00	0.00
Education Fund	10 E 2560 4100 00 302 000000	0.00	0.00	0.00	0.00	0.00	0.00	0.00
Education Fund	10 E 2560 4100 00 302 000001	0.00	0.00	0.00	0.00	0.00	0.00	0.00
Education Fund	10 E 2560 5400 00 300 000000	5,000.00	0.00	0.00	0.00	5,000.00	0.00	0.00
Education Fund	10 E 2560 5400 00 302 000000	0.00	0.00	0.00	0.00	0.00	0.00	0.00
Education Fund	10 E 2560 6900 00 302 000000	3,000.00	0.00	0.00	0.00	1,753.70	1,246.30	41.54
Education Fund	10 E 2632 1100 00 300 000000	27,781.44	2,115.66	0.00	0.00	10,680.27	17,101.17	61.56
Education Fund	10 E 2632 2110 00 300 000000	0.00	0.00	0.00	0.00	0.00	0.00	0.00
Education Fund	10 E 2632 2220 00 300 000000	25,467.04	1,457.00	0.00	-0.52	12,537.45	12,930.11	50.77
Education Fund	10 E 2632 2230 00 300 000000	0.00	18.40	0.00	0.00	-55.20	55.20	0.00
Education Fund	10 E 2632 3000 00 300 000000	250,000.00	16,406.06	0.00	16,406.06	69,699.62	163,894.32	65.56
Education Fund	10 E 2632 3230 00 300 000000	0.00	0.00	0.00	0.00	0.00	0.00	0.00

Expenditure Report

Fiscal Year: 2020-2021
Month: March

COUNTY OF GRUNDY SCHOOL DIST 111

Fund Description	Account Number	Revised Budget	MTD Activity	Encumbrance	Pending Activity	Available Funds	Year to Date Activity	Percent of Budget Used
Education Fund	10 E 2632 4100 00 000 000000	0.00	0.00	0.00	0.00	0.00	0.00	0.00
Education Fund	10 E 2632 4100 00 300 000000	40,000.00	0.00	0.00	356.30	37,941.99	1,701.71	4.25
Education Fund	10 E 2632 5400 00 300 000000	0.00	0.00	0.00	0.00	0.00	0.00	0.00
Education Fund	10 E 2633 1100 00 300 000000	69,628.00	5,802.34	0.00	0.00	17,406.94	52,221.06	75.00
Education Fund	10 E 2633 2220 00 300 000000	0.00	4.00	0.00	-0.52	-28.52	29.04	0.00
Education Fund	10 E 2633 3000 00 300 000000	9,300.00	0.00	0.00	0.00	3,443.34	5,856.66	62.97
Education Fund	10 E 2633 3230 00 300 000000	0.00	0.00	0.00	0.00	0.00	0.00	0.00
Education Fund	10 E 2633 3320 00 300 000000	0.00	0.00	0.00	0.00	0.00	0.00	0.00
Education Fund	10 E 2633 4100 00 300 000000	0.00	0.00	0.00	103.48	-103.48	0.00	0.00
Education Fund	10 E 2633 5400 00 300 000000	0.00	0.00	0.00	0.00	0.00	0.00	0.00
Education Fund	10 E 2633 6400 00 300 000000	1,000.00	0.00	0.00	0.00	610.00	390.00	39.00
Education Fund	10 E 2900 4000 00 300 000000	1,000.00	0.00	0.00	0.00	1,000.00	0.00	0.00
Education Fund	10 E 3000 3000 00 300 000000	700.00	0.00	0.00	0.00	700.00	0.00	0.00
Education Fund	10 E 3000 4100 00 300 000000	1,000.00	0.00	0.00	0.00	1,000.00	0.00	0.00
Education Fund	10 E 3200 1300 00 300 000000	0.00	0.00	0.00	0.00	0.00	0.00	0.00
Education Fund	10 E 3200 1300 00 300 000001	0.00	0.00	0.00	0.00	0.00	0.00	0.00
Education Fund	10 E 3200 2110 00 300 000000	0.00	0.00	0.00	0.00	0.00	0.00	0.00
Education Fund	10 E 3200 2220 00 300 000000	0.00	0.00	0.00	0.00	0.00	0.00	0.00
Education Fund	10 E 3200 5000 00 300 000000	12,000.00	0.00	11,092.40	0.00	907.60	0.00	0.00
Education Fund	10 E 4000 6000 00 000 000000	0.00	0.00	0.00	0.00	-172,024.00	172,024.00	0.00
Education Fund	10 E 4100 1100 00 300 000000	0.00	0.00	0.00	0.00	0.00	0.00	0.00
Education Fund	10 E 4100 3000 00 300 000000	0.00	0.00	0.00	0.00	0.00	0.00	0.00
Education Fund	10 E 4100 3320 00 300 221000	0.00	0.00	0.00	0.00	0.00	0.00	0.00
Education Fund	10 E 4100 3900 00 300 000000	0.00	0.00	0.00	0.00	0.00	0.00	0.00
Education Fund	10 E 4100 4100 00 300 212000	0.00	0.00	0.00	0.00	0.00	0.00	0.00
Education Fund	10 E 4100 4100 00 300 222000	0.00	0.00	0.00	0.00	0.00	0.00	0.00
Education Fund	10 E 4100 5400 00 300 100000	0.00	0.00	0.00	0.00	0.00	0.00	0.00
Education Fund	10 E 4120 3000 00 300 000000	0.00	0.00	0.00	0.00	0.00	0.00	0.00
Education Fund	10 E 4120 3000 00 300 000001	165,000.00	0.00	0.00	0.00	165,000.00	0.00	0.00
Education Fund	10 E 4120 6700 00 000 000000	15,000.00	0.00	0.00	0.00	15,000.00	0.00	0.00
Education Fund	10 E 4140 6000 00 000 000000	765,000.00	0.00	0.00	52,193.97	252,576.03	460,230.00	60.16
Education Fund	10 E 4180 0000 00 000 000000	0.00	0.00	0.00	0.00	0.00	0.00	0.00
Education Fund	10 E 4190 6000 00 300 000000	64,429.04	0.00	0.00	0.00	0.00	64,429.04	100.00

273

Expenditure Report

Fiscal Year: 2020-2021
Month: March

COUNTY OF GRUNDY SCHOOL DIST 111

Fund Description	Account Number	Revised Budget	MTD Activity	Encumbrance	Pending Activity	Available Funds	Year to Date Activity	Percent of Budget Used
Education Fund	10 E 4210 6700 00 000 000000	10,000.00	0.00	0.00	0.00	10,000.00	0.00	0.00
Education Fund	10 E 4220 6700 00 000 000000	2,254,957.00	-3,618.57	0.00	0.00	1,088,527.61	1,166,429.39	51.73
Education Fund	10 E 4810 2120 00 454 000000	0.00	0.00	0.00	0.00	0.00	0.00	0.00
Education Fund	10 E 4810 2120 00 454 000001	0.00	0.00	0.00	0.00	0.00	0.00	0.00
Education Fund	10 E 4810 2220 00 454 000000	0.00	0.00	0.00	0.00	0.00	0.00	0.00
Education Fund	10 E 4810 2220 00 454 000001	0.00	0.00	0.00	0.00	0.00	0.00	0.00
Education Fund	10 E 5900 3900 00 300 000000	0.00	0.00	0.00	0.00	0.00	0.00	0.00
Education Fund	10 E 8130 6600 00 300 000000	0.00	0.00	0.00	0.00	0.00	0.00	0.00
Education Fund	10 E 8400 6600 00 300 000000	0.00	0.00	0.00	0.00	0.00	0.00	0.00
Education Fund	10 E 8500 6600 00 300 000000	0.00	0.00	0.00	0.00	0.00	0.00	0.00
10 - - - - -		30,914,069.05	2,579,935.17	108,225.32	434,528.79	6,709,002.41	23,662,312.53	
Activity Fund	11 E 1999 4100 00 300 000000	250,000.00	0.00	0.00	0.00	250,000.00	0.00	0.00
Activity Fund	11 E 1999 4100 30 300 910001	0.00	0.00	0.00	0.00	0.00	0.00	274 0.00
Activity Fund	11 E 1999 4100 30 300 910002	0.00	1,872.50	0.00	0.00	-9,033.60	9,033.60	0.00
Activity Fund	11 E 1999 4100 30 300 910003	0.00	0.00	0.00	0.00	0.00	0.00	0.00
Activity Fund	11 E 1999 4100 30 300 910004	0.00	75.00	0.00	0.00	-1,524.75	75.00	0.00
Activity Fund	11 E 1999 4100 30 300 910005	0.00	500.00	0.00	0.00	-6,377.20	6,377.20	0.00
Activity Fund	11 E 1999 4100 30 300 910006	0.00	0.00	0.00	0.00	0.00	0.00	0.00
Activity Fund	11 E 1999 4100 30 300 910007	0.00	0.00	0.00	0.00	-369.00	369.00	0.00
Activity Fund	11 E 1999 4100 30 300 910008	0.00	10.88	0.00	0.00	-3,580.46	3,560.46	0.00
Activity Fund	11 E 1999 4100 30 300 910009	0.00	0.00	0.00	0.00	-337.50	337.50	0.00
Activity Fund	11 E 1999 4100 30 300 910010	0.00	0.00	0.00	0.00	-11,619.28	11,619.28	0.00
Activity Fund	11 E 1999 4100 30 300 910011	0.00	0.00	0.00	0.00	0.00	0.00	0.00
Activity Fund	11 E 1999 4100 30 300 910012	0.00	1,536.50	0.00	0.00	-18,372.33	18,372.33	0.00
Activity Fund	11 E 1999 4100 30 300 910013	0.00	86.38	0.00	0.00	-5,199.85	5,199.85	0.00
Activity Fund	11 E 1999 4100 30 300 910014	0.00	3,392.59	0.00	0.00	-27,143.91	27,143.91	0.00
Activity Fund	11 E 1999 4100 30 300 910015	0.00	0.00	0.00	0.00	0.00	0.00	0.00
Activity Fund	11 E 1999 4100 30 300 910016	0.00	0.00	0.00	0.00	-225.00	225.00	0.00
Activity Fund	11 E 1999 4100 30 300 910017	0.00	0.00	0.00	0.00	-640.00	640.00	0.00
Activity Fund	11 E 1999 4100 30 300 910018	0.00	0.00	0.00	0.00	0.00	0.00	0.00
Activity Fund	11 E 1999 4100 30 300 910019	0.00	0.00	0.00	0.00	-3,709.95	3,709.95	0.00
Activity Fund	11 E 1999 4100 30 300 910020	0.00	0.00	0.00	0.00	-1,450.85	1,450.85	0.00

Expenditure Report

Fiscal Year: 2020-2021
Month: March

COUNTY OF GRUNDY SCHOOL DIST 111

Fund Description	Account Number	Revised Budget	MTD Activity	Encumbrance	Pending Activity	Available Funds	Year to Date Activity	Percent of Budget Used
Activity Fund	11 E 1999 4100 30 300 910021	0.00	300.00	0.00	0.00	-300.00	300.00	0.00
Activity Fund	11 E 1999 4100 30 300 910022	0.00	535.00	0.00	0.00	-2,981.28	2,981.28	0.00
Activity Fund	11 E 1999 4100 30 300 910023	0.00	0.00	0.00	0.00	-6,306.60	6,306.60	0.00
Activity Fund	11 E 1999 4100 30 300 910024	0.00	0.00	0.00	0.00	0.00	0.00	0.00
Activity Fund	11 E 1999 4100 30 300 910025	0.00	520.00	0.00	0.00	-660.00	660.00	0.00
Activity Fund	11 E 1999 4100 30 300 910026	0.00	0.00	0.00	0.00	0.00	0.00	0.00
Activity Fund	11 E 1999 4100 30 300 910027	0.00	0.00	0.00	0.00	0.00	0.00	0.00
Activity Fund	11 E 1999 4100 30 300 910028	0.00	0.00	0.00	0.00	0.00	0.00	0.00
Activity Fund	11 E 1999 4100 30 300 910029	0.00	0.00	0.00	0.00	0.00	0.00	0.00
Activity Fund	11 E 1999 4100 30 300 910030	0.00	0.00	0.00	0.00	0.00	0.00	0.00
Activity Fund	11 E 1999 4100 30 300 910031	0.00	0.00	0.00	0.00	0.00	0.00	0.00
Activity Fund	11 E 1999 4100 30 300 910032	0.00	0.00	0.00	0.00	0.00	0.00	0.00
Activity Fund	11 E 1999 4100 30 300 910033	0.00	0.00	0.00	0.00	0.00	0.00	0.00
Activity Fund	11 E 1999 4100 30 300 910034	0.00	0.00	0.00	0.00	0.00	0.00	0.00
Activity Fund	11 E 1999 4100 30 300 910035	0.00	0.00	0.00	0.00	0.00	0.00	275 0.00
Activity Fund	11 E 1999 4100 30 300 910036	0.00	0.00	0.00	0.00	0.00	0.00	0.00
Activity Fund	11 E 1999 4100 30 300 910037	0.00	0.00	0.00	0.00	0.00	0.00	0.00
Activity Fund	11 E 1999 4100 30 300 910038	0.00	0.00	0.00	0.00	0.00	0.00	0.00
Activity Fund	11 E 1999 4100 30 300 910039	0.00	0.00	0.00	0.00	0.00	0.00	0.00
Activity Fund	11 E 1999 4100 30 300 910040	0.00	0.00	0.00	0.00	0.00	0.00	0.00
Activity Fund	11 E 1999 4100 30 300 910041	0.00	0.00	0.00	0.00	0.00	0.00	0.00
Activity Fund	11 E 1999 4100 30 300 910042	0.00	0.00	0.00	0.00	0.00	0.00	0.00
Activity Fund	11 E 1999 4100 70 300 900001	0.00	0.00	0.00	0.00	-2,483.30	2,483.30	0.00
Activity Fund	11 E 1999 4100 70 300 900002	0.00	0.00	0.00	0.00	0.00	0.00	0.00
Activity Fund	11 E 1999 4100 70 300 900003	0.00	0.00	0.00	0.00	0.00	0.00	0.00
Activity Fund	11 E 1999 4100 70 300 900004	0.00	0.00	0.00	0.00	0.00	0.00	0.00
Activity Fund	11 E 1999 4100 70 300 900005	0.00	0.00	0.00	0.00	0.00	0.00	0.00
Activity Fund	11 E 1999 4100 70 300 900006	0.00	0.00	0.00	0.00	0.00	0.00	0.00
Activity Fund	11 E 1999 4100 70 300 900007	0.00	0.00	0.00	0.00	0.00	0.00	0.00
Activity Fund	11 E 1999 4100 70 300 900008	0.00	0.00	0.00	0.00	0.00	0.00	0.00
Activity Fund	11 E 1999 4100 70 300 900009	0.00	0.00	0.00	0.00	0.00	0.00	0.00
Activity Fund	11 E 1999 4100 70 300 900010	0.00	0.00	0.00	0.00	-232.90	232.90	0.00
Activity Fund	11 E 1999 4100 70 300 900011	0.00	35.00	0.00	0.00	-35.00	35.00	0.00

Expenditure Report

Fiscal Year: 2020-2021
Month: March

COUNTY OF GRUNDY SCHOOL DIST 111

Fund Description	Account Number	Revised Budget	MTD Activity	Encumbrance	Pending Activity	Available Funds	Year to Date Activity	Percent of Budget Used
Activity Fund	11 E 1999 4100 70 300 900012	0.00	509.00	0.00	0.00	-509.00	509.00	0.00
Activity Fund	11 E 1999 4100 70 300 900013	0.00	20.00	0.00	0.00	-20.00	20.00	0.00
Activity Fund	11 E 1999 4100 70 300 900014	0.00	0.00	0.00	0.00	0.00	0.00	0.00
Activity Fund	11 E 1999 4100 70 300 900015	0.00	0.00	0.00	0.00	0.00	0.00	0.00
Activity Fund	11 E 1999 4100 70 300 900016	0.00	0.00	0.00	0.00	0.00	0.00	0.00
Activity Fund	11 E 1999 4100 70 300 900017	0.00	0.00	0.00	0.00	0.00	0.00	0.00
Activity Fund	11 E 1999 4100 70 300 900018	0.00	0.00	0.00	0.00	0.00	0.00	0.00
Activity Fund	11 E 1999 4100 70 300 900019	0.00	0.00	0.00	0.00	0.00	0.00	0.00
Activity Fund	11 E 1999 4100 70 300 900020	0.00	0.00	0.00	0.00	-121.78	121.78	0.00
Activity Fund	11 E 1999 4100 70 300 900021	0.00	0.00	0.00	0.00	0.00	0.00	0.00
Activity Fund	11 E 1999 4100 70 300 900022	0.00	0.00	0.00	0.00	0.00	0.00	0.00
Activity Fund	11 E 1999 4100 70 300 900023	0.00	0.00	0.00	0.00	0.00	0.00	0.00
Activity Fund	11 E 1999 4100 70 300 900024	0.00	0.00	0.00	0.00	0.00	0.00	0.00
Activity Fund	11 E 1999 4100 70 300 900025	0.00	0.00	0.00	0.00	0.00	0.00	0.00
Activity Fund	11 E 1999 4100 70 300 900026	0.00	0.00	0.00	0.00	-481.53	481.53	0.00
Activity Fund	11 E 1999 4100 70 300 900027	0.00	0.00	0.00	0.00	0.00	0.00	0.00
Activity Fund	11 E 1999 4100 70 300 900028	0.00	0.00	0.00	0.00	-32.65	32.65	0.00
Activity Fund	11 E 1999 4100 70 300 900029	0.00	0.00	0.00	0.00	0.00	0.00	0.00
Activity Fund	11 E 1999 4100 70 300 900030	0.00	0.00	0.00	0.00	-105.00	105.00	0.00
Activity Fund	11 E 1999 4100 70 300 900031	0.00	0.00	0.00	0.00	0.00	0.00	0.00
Activity Fund	11 E 1999 4100 70 300 900032	0.00	1,284.65	0.00	0.00	-6,304.97	6,304.97	0.00
Activity Fund	11 E 1999 4100 70 300 900033	0.00	0.00	0.00	0.00	0.00	0.00	0.00
Activity Fund	11 E 1999 4100 70 300 900034	0.00	0.00	0.00	0.00	0.00	0.00	0.00
Activity Fund	11 E 1999 4100 70 300 900035	0.00	0.00	0.00	0.00	0.00	0.00	0.00
Activity Fund	11 E 1999 4100 70 300 900036	0.00	0.00	0.00	0.00	-20.00	20.00	0.00
Activity Fund	11 E 1999 4100 70 300 900037	0.00	0.00	0.00	0.00	-766.16	766.16	0.00
Activity Fund	11 E 1999 4100 70 300 900038	0.00	0.00	0.00	0.00	-3,095.00	3,095.00	0.00
Activity Fund	11 E 1999 4100 70 300 900039	0.00	0.00	0.00	0.00	0.00	0.00	0.00
Activity Fund	11 E 1999 4100 70 300 900040	0.00	0.00	0.00	0.00	0.00	0.00	0.00
Activity Fund	11 E 1999 4100 70 300 900041	0.00	0.00	0.00	0.00	0.00	0.00	0.00
Activity Fund	11 E 1999 4100 70 300 900042	0.00	0.00	0.00	0.00	0.00	0.00	0.00
Activity Fund	11 E 1999 4100 70 300 900043	0.00	0.00	0.00	0.00	0.00	0.00	0.00
Activity Fund	11 E 1999 4100 70 300 900044	0.00	0.00	0.00	0.00	0.00	0.00	0.00

276

Expenditure Report

Fiscal Year: 2020-2021
Month: March

COUNTY OF GRUNDY SCHOOL DIST 111

Fund Description	Account Number	Revised Budget	MTD Activity	Encumbrance	Pending Activity	Available Funds	Year to Date Activity	Percent of Budget Used
Activity Fund	11 E 1999 4100 70 300 900045	0.00	0.00	0.00	0.00	0.00	0.00	0.00
Activity Fund	11 E 1999 4100 70 300 900046	0.00	0.00	0.00	0.00	-377.58	377.58	0.00
Activity Fund	11 E 1999 4100 70 300 900047	0.00	0.00	0.00	0.00	0.00	0.00	0.00
Activity Fund	11 E 1999 4100 70 300 900048	0.00	1,674.97	0.00	0.00	-7,061.23	7,061.23	0.00
Activity Fund	11 E 1999 4100 70 300 900049	0.00	0.00	0.00	0.00	-785.00	785.00	0.00
Activity Fund	11 E 1999 4100 70 300 900050	0.00	0.00	0.00	0.00	0.00	0.00	0.00
Activity Fund	11 E 1999 4100 70 300 900051	0.00	0.00	0.00	0.00	-180.00	180.00	0.00
Activity Fund	11 E 1999 4100 70 300 900052	0.00	0.00	0.00	0.00	0.00	0.00	0.00
Activity Fund	11 E 1999 4100 70 300 900053	0.00	0.00	0.00	0.00	-2,500.00	2,500.00	0.00
Activity Fund	11 E 1999 4100 70 300 900054	0.00	0.00	0.00	0.00	0.00	0.00	0.00
Activity Fund	11 E 1999 4100 70 300 900055	0.00	0.00	0.00	0.00	0.00	0.00	0.00
Activity Fund	11 E 1999 4100 70 300 900056	0.00	0.00	0.00	0.00	0.00	0.00	0.00
Activity Fund	11 E 1999 4100 70 300 900057	0.00	0.00	0.00	0.00	0.00	0.00	0.00
Activity Fund	11 E 1999 4100 70 300 900058	0.00	0.00	0.00	0.00	0.00	0.00	0.00
Activity Fund	11 E 1999 4100 70 300 900059	0.00	0.00	0.00	0.00	-2,500.00	2,500.00	0.00
Activity Fund	11 E 1999 4100 70 300 900060	0.00	0.00	0.00	0.00	0.00	0.00	0.00
Activity Fund	11 E 1999 8000 01 000 900000	0.00	0.00	0.00	0.00	0.00	0.00	0.00
11 -	-----	250,000.00	12,352.47	0.00	0.00	122,557.34	125,972.91	277
1-	-----	31,164,069.05	2,592,287.64	108,225.32	434,528.79	6,831,559.75	23,788,285.44	
Operations & Maint Fund	20 E 1130 2220 00 000 000000	0.00	6,439.60	0.00	6,012.21	-49,417.24	43,405.03	0.00
Operations & Maint Fund	20 E 1130 2230 00 000 000000	0.00	192.98	0.00	809.15	-3,979.43	3,170.28	0.00
Operations & Maint Fund	20 E 2220 0000 00 000 000000	0.00	0.00	0.00	0.00	0.00	0.00	0.00
Operations & Maint Fund	20 E 2310 2000 00 300 000000	0.00	0.00	0.00	0.00	0.00	0.00	0.00
Operations & Maint Fund	20 E 2510 1100 00 300 000000	55,992.59	4,666.06	0.00	0.00	13,998.05	41,994.54	75.00
Operations & Maint Fund	20 E 2510 2110 00 300 000000	0.00	0.00	0.00	0.00	0.00	0.00	0.00
Operations & Maint Fund	20 E 2510 2210 00 300 000000	0.00	0.00	0.00	0.00	0.00	0.00	0.00
Operations & Maint Fund	20 E 2510 2220 00 300 000000	9,200.00	745.54	0.00	0.00	2,949.26	6,250.74	67.94
Operations & Maint Fund	20 E 2510 2230 00 300 000000	0.00	39.12	0.00	0.00	-117.36	117.36	0.00
Operations & Maint Fund	20 E 2510 3320 00 300 000000	0.00	0.00	0.00	0.00	0.00	0.00	0.00
Operations & Maint Fund	20 E 2510 6400 00 300 000000	0.00	0.00	0.00	0.00	0.00	0.00	0.00
Operations & Maint Fund	20 E 2540 1100 00 300 000000	0.00	0.00	0.00	0.00	0.00	0.00	0.00

Expenditure Report

Fiscal Year: 2020-2021
Month: March

COUNTY OF GRUNDY SCHOOL DIST 111

Fund Description	Account Number	Revised Budget	MTD Activity	Encumbrance	Pending Activity	Available Funds	Year to Date Activity	Percent of Budget Used
Operations & Maint Fund	20 E 2540 1100 00 300 000001	700,000.00	54,628.17	0.00	0.00	245,921.17	454,078.83	64.87
Operations & Maint Fund	20 E 2540 1100 00 302 000000	0.00	0.00	0.00	0.00	-7,465.48	7,465.48	0.00
Operations & Maint Fund	20 E 2540 1300 00 300 000000	30,000.00	1,539.61	0.00	0.00	20,310.94	9,689.06	32.30
Operations & Maint Fund	20 E 2540 1300 00 300 000001	0.00	0.00	0.00	0.00	0.00	0.00	0.00
Operations & Maint Fund	20 E 2540 2110 00 300 000000	0.00	0.00	0.00	0.00	0.00	0.00	0.00
Operations & Maint Fund	20 E 2540 2220 00 300 000000	205,000.00	-2,379.43	0.00	-5.60	206,223.62	-1,218.02	-0.59
Operations & Maint Fund	20 E 2540 2220 00 300 000001	0.00	15,745.79	0.00	0.00	-128,442.43	128,442.43	0.00
Operations & Maint Fund	20 E 2540 2220 00 302 000000	0.00	0.00	0.00	0.00	0.00	0.00	0.00
Operations & Maint Fund	20 E 2540 2230 00 300 000001	0.00	588.80	0.00	0.00	-1,545.60	1,545.60	0.00
Operations & Maint Fund	20 E 2540 3000 00 300 000000	0.00	0.00	0.00	0.00	0.00	0.00	0.00
Operations & Maint Fund	20 E 2540 3000 00 300 000001	35,000.00	0.00	0.00	0.00	22,628.16	12,371.84	35.35
Operations & Maint Fund	20 E 2540 3000 00 300 000002	65,000.00	0.00	0.00	0.00	60,596.24	4,403.76	6.78
Operations & Maint Fund	20 E 2540 3000 00 300 000003	15,000.00	0.00	0.00	0.00	15,000.00	0.00	0.00
Operations & Maint Fund	20 E 2540 3000 00 300 000004	25,000.00	10,530.70	0.00	0.00	6,223.47	18,776.53	75.11
Operations & Maint Fund	20 E 2540 3000 00 300 000005	2,000.00	185.00	0.00	185.00	520.00	1,295.00	64.75
Operations & Maint Fund	20 E 2540 3000 00 302 000000	88,000.00	0.00	1,500.00	-2,402.20	40,688.66	48,213.54	54.79
Operations & Maint Fund	20 E 2540 3000 00 302 000001	5,000.00	0.00	77.95	0.00	4,922.05	0.00	0.00
Operations & Maint Fund	20 E 2540 3000 00 302 000002	25,000.00	14,481.60	0.00	0.00	4,317.22	20,682.78	82.73
Operations & Maint Fund	20 E 2540 3000 00 302 000003	2,500.00	175.00	0.00	175.00	1,100.00	1,225.00	49.00
Operations & Maint Fund	20 E 2540 3100 00 300 000000	0.00	0.00	0.00	0.00	0.00	0.00	0.00
Operations & Maint Fund	20 E 2540 3100 00 300 000001	0.00	0.00	0.00	0.00	0.00	0.00	0.00
Operations & Maint Fund	20 E 2540 3190 00 300 000000	0.00	0.00	0.00	0.00	0.00	0.00	0.00
Operations & Maint Fund	20 E 2540 3200 00 300 000000	0.00	0.00	0.00	0.00	0.00	0.00	0.00
Operations & Maint Fund	20 E 2540 3200 00 301 000000	22,000.00	1,660.80	0.00	1,660.80	5,392.00	14,947.20	67.94
Operations & Maint Fund	20 E 2540 3210 00 300 000000	35,000.00	2,993.45	0.00	2,995.29	5,933.02	26,071.69	74.49
Operations & Maint Fund	20 E 2540 3210 00 302 000000	46,000.00	4,399.07	0.00	4,449.60	7,362.27	34,188.13	74.32
Operations & Maint Fund	20 E 2540 3220 00 300 000000	0.00	0.00	0.00	0.00	0.00	0.00	0.00
Operations & Maint Fund	20 E 2540 3230 00 300 000000	90,000.00	3,659.64	0.00	6,533.83	63,486.20	19,979.97	22.20
Operations & Maint Fund	20 E 2540 3230 00 300 000001	0.00	0.00	0.00	0.00	0.00	0.00	0.00
Operations & Maint Fund	20 E 2540 3230 00 302 000000	85,000.00	2,689.90	0.00	100.00	40,448.32	44,451.68	52.30
Operations & Maint Fund	20 E 2540 3230 00 302 000001	0.00	14,028.00	0.00	0.00	-21,193.12	21,193.12	0.00
Operations & Maint Fund	20 E 2540 3320 00 300 000000	1,000.00	0.00	0.00	0.00	1,000.00	0.00	0.00
Operations & Maint Fund	20 E 2540 3400 00 300 000000	0.00	0.00	0.00	0.00	0.00	0.00	0.00

Expenditure Report

Fiscal Year: 2020-2021
Month: March

COUNTY OF GRUNDY SCHOOL DIST 111

Fund Description	Account Number	Revised Budget	MTD Activity	Encumbrance	Pending Activity	Available Funds	Year to Date Activity	Percent of Budget Used
Operations & Maint Fund	20 E 2540 3400 00 300 000001	65,000.00	6,195.34	0.00	5,651.84	3,463.98	55,884.18	85.98
Operations & Maint Fund	20 E 2540 3400 00 301 000000	2,200.00	261.40	0.00	109.21	498.49	1,592.30	72.38
Operations & Maint Fund	20 E 2540 3700 00 300 000000	22,000.00	216.66	0.00	0.00	17,976.38	4,023.62	18.29
Operations & Maint Fund	20 E 2540 3700 00 302 000000	25,000.00	1,322.95	0.00	1,578.39	8,642.60	14,779.01	59.12
Operations & Maint Fund	20 E 2540 3800 00 300 000000	0.00	0.00	0.00	0.00	0.00	0.00	0.00
Operations & Maint Fund	20 E 2540 3800 00 300 000001	0.00	0.00	0.00	0.00	0.00	0.00	0.00
Operations & Maint Fund	20 E 2540 3800 00 300 000002	0.00	0.00	0.00	0.00	0.00	0.00	0.00
Operations & Maint Fund	20 E 2540 3900 00 300 000000	0.00	0.00	0.00	0.00	0.00	0.00	0.00
Operations & Maint Fund	20 E 2540 3900 00 302 000000	60,000.00	1,061.14	0.00	4,821.50	42,709.95	12,468.55	20.78
Operations & Maint Fund	20 E 2540 3900 00 302 000001	550,000.00	52,059.83	0.00	52,059.83	-72,593.22	570,533.39	103.73
Operations & Maint Fund	20 E 2540 3900 00 302 000002	0.00	0.00	0.00	0.00	0.00	0.00	0.00
Operations & Maint Fund	20 E 2540 3900 00 302 000003	0.00	0.00	0.00	0.00	0.00	0.00	0.00
Operations & Maint Fund	20 E 2540 3900 00 302 000004	0.00	0.00	0.00	0.00	0.00	0.00	0.00
Operations & Maint Fund	20 E 2540 4100 00 300 000000	350,000.00	5,497.35	176.75	4,853.83	217,918.20	127,051.22	279.36.30
Operations & Maint Fund	20 E 2540 4100 00 300 000001	35,000.00	1,361.46	0.00	2,436.74	14,920.29	17,642.97	50.41
Operations & Maint Fund	20 E 2540 4100 00 302 000000	25,000.00	5,510.24	0.00	1,838.59	-3,119.59	26,281.00	105.12
Operations & Maint Fund	20 E 2540 4100 00 302 000001	12,000.00	0.00	0.00	0.00	6,128.07	5,871.93	48.93
Operations & Maint Fund	20 E 2540 4650 00 300 000000	60,000.00	13,856.68	0.00	1,467.78	-4,842.00	63,374.22	105.62
Operations & Maint Fund	20 E 2540 4650 00 302 000000	38,000.00	7,114.22	0.00	843.20	15,612.48	21,544.32	56.70
Operations & Maint Fund	20 E 2540 4660 00 300 000000	265,000.00	18,880.40	0.00	21,008.85	106,894.15	137,097.00	51.73
Operations & Maint Fund	20 E 2540 4660 00 302 000000	315,000.00	23,807.62	0.00	22,470.90	94,930.10	197,599.00	62.73
Operations & Maint Fund	20 E 2540 4700 00 300 000000	0.00	0.00	0.00	0.00	0.00	0.00	0.00
Operations & Maint Fund	20 E 2540 5400 00 300 000000	55,000.00	0.00	0.00	33,425.00	14,500.98	7,074.02	12.86
Operations & Maint Fund	20 E 2540 5400 00 300 000001	0.00	0.00	0.00	0.00	0.00	0.00	0.00
Operations & Maint Fund	20 E 2540 5400 00 301 000000	2,500.00	0.00	0.00	0.00	2,500.00	0.00	0.00
Operations & Maint Fund	20 E 2540 5400 00 302 000000	15,000.00	100.00	13,376.00	100.00	1,424.00	100.00	0.67
Operations & Maint Fund	20 E 2540 6400 00 300 000000	500.00	0.00	0.00	0.00	500.00	0.00	0.00
Operations & Maint Fund	20 E 2540 6900 00 300 000000	3,600.00	0.00	0.00	0.00	1,771.52	1,828.48	50.79
Operations & Maint Fund	20 E 2541 1200 00 300 000000	35,000.00	0.00	0.00	0.00	26,023.37	8,976.63	25.65
Operations & Maint Fund	20 E 2541 3900 00 300 000000	0.00	0.00	0.00	0.00	0.00	0.00	0.00
Operations & Maint Fund	20 E 2541 3900 00 300 000001	25,000.00	0.00	0.00	0.00	25,000.00	0.00	0.00
Operations & Maint Fund	20 E 2541 3900 00 302 000000	0.00	0.00	0.00	0.00	0.00	0.00	0.00
Operations & Maint Fund	20 E 2541 3900 00 302 000001	0.00	0.00	0.00	0.00	0.00	0.00	0.00

Expenditure Report

Fiscal Year: 2020-2021
Month: March

COUNTY OF GRUNDY SCHOOL DIST 111

Fund Description	Account Number	Revised Budget	MTD Activity	Encumbrance	Pending Activity	Available Funds	Year to Date Activity	Percent of Budget Used
Operations & Maint Fund	20 E 2541 4100 00 300 000000	10,000.00	0.00	0.00	0.00	10,000.00	0.00	0.00
Operations & Maint Fund	20 E 2541 4100 00 302 000000	0.00	0.00	0.00	0.00	0.00	0.00	0.00
Operations & Maint Fund	20 E 2541 5400 00 300 000000	25,000.00	0.00	0.00	0.00	25,000.00	0.00	0.00
Operations & Maint Fund	20 E 2541 5400 00 302 000000	25,000.00	0.00	0.00	0.00	25,000.00	0.00	0.00
Operations & Maint Fund	20 E 2542 5300 00 300 000000	50,000.00	0.00	0.00	0.00	9,864.00	40,136.00	80.27
Operations & Maint Fund	20 E 2542 5300 00 300 000001	50,000.00	0.00	0.00	0.00	50,000.00	0.00	0.00
Operations & Maint Fund	20 E 2542 5300 00 302 000000	20,000.00	0.00	807.04	0.00	-1,667.04	20,860.00	104.30
Operations & Maint Fund	20 E 2542 5300 00 302 000001	20,000.00	0.00	0.00	0.00	20,000.00	0.00	0.00
Operations & Maint Fund	20 E 2543 5400 00 300 000000	25,000.00	0.00	0.00	0.00	20,200.00	4,800.00	19.20
Operations & Maint Fund	20 E 2549 3800 00 300 000000	0.00	0.00	0.00	0.00	0.00	0.00	0.00
Operations & Maint Fund	20 E 4140 5200 00 300 000000	0.00	0.00	0.00	0.00	0.00	0.00	0.00
Operations & Maint Fund	20 E 4140 6000 00 000 000000	380,000.00	11,772.96	0.00	15,423.18	151,392.23	213,184.59	56.10
Operations & Maint Fund	20 E 4140 6000 00 000 000001	0.00	0.00	0.00	0.00	0.00	0.00	0.00
Operations & Maint Fund	20 E 4810 2220 00 454 000000	0.00	0.00	0.00	0.00	0.00	0.00	0.00
Operations & Maint Fund	20 E 4810 2220 00 454 000001	0.00	0.00	0.00	0.00	0.00	0.00	0.00
Operations & Maint Fund	20 E 8130 6610 00 300 000000	0.00	0.00	0.00	0.00	0.00	0.00	0.00
Operations & Maint Fund	20 E 8400 6610 00 300 000000	0.00	0.00	0.00	0.00	0.00	0.00	0.00
Operations & Maint Fund	20 E 8800 6600 00 300 000000	0.00	0.00	0.00	0.00	0.00	0.00	0.00
20 - - - - -		4,107,492.59	286,027.65	15,937.74	188,601.92	1,387,508.93	2,515,444.00	
2- - - - -		4,107,492.59	286,027.65	15,937.74	188,601.92	1,387,508.93	2,515,444.00	
Debt Service Fund or Fund	30 E 4190 6900 00 300 000000	0.00	0.00	0.00	0.00	0.00	0.00	0.00
Debt Service Fund or Fund	30 E 5140 6200 00 300 000000	0.00	0.00	0.00	0.00	0.00	0.00	0.00
Debt Service Fund or Fund	30 E 5140 6200 00 300 000001	0.00	0.00	0.00	0.00	0.00	0.00	0.00
Debt Service Fund or Fund	30 E 5140 6200 00 300 000002	0.00	0.00	0.00	0.00	0.00	0.00	0.00
Debt Service Fund or Fund	30 E 5140 6200 00 300 000003	0.00	0.00	0.00	0.00	0.00	0.00	0.00
Debt Service Fund or Fund	30 E 5140 6200 00 300 000004	0.00	0.00	0.00	0.00	0.00	0.00	0.00
Debt Service Fund or Fund	30 E 5140 6200 00 300 000005	0.00	0.00	0.00	0.00	-443,125.00	443,125.00	0.00
Debt Service Fund or Fund	30 E 5140 6200 00 300 000006	0.00	0.00	0.00	0.00	0.00	0.00	0.00
Debt Service Fund or Fund	30 E 5140 6200 00 300 000007	0.00	0.00	0.00	0.00	0.00	0.00	0.00
Debt Service Fund or Fund	30 E 5140 6210 00 000 000000	16,666.50	8,333.25	0.00	0.00	0.00	16,666.50	100.00
Debt Service Fund or Fund	30 E 5140 6210 00 000 000001	284,100.00	142,050.00	0.00	0.00	0.00	284,100.00	100.00

Expenditure Report

Fiscal Year: 2020-2021
Month: March

COUNTY OF GRUNDY SCHOOL DIST 111

Fund Description	Account Number	Revised Budget	MTD Activity	Encumbrance	Pending Activity	Available Funds	Year to Date Activity	Percent of Budget Used
Debt Service Fund or Fund	30 E 5140 6210 00 300 000000	0.00	0.00	0.00	0.00	0.00	0.00	0.00
Debt Service Fund or Fund	30 E 5140 6210 00 300 000001	339,675.00	154,875.00	0.00	0.00	16,800.00	322,875.00	95.05
Debt Service Fund or Fund	30 E 5140 6210 00 300 000002	0.00	0.00	0.00	0.00	0.00	0.00	0.00
Debt Service Fund or Fund	30 E 5140 6210 00 300 000003	365,200.00	182,600.00	0.00	0.00	0.00	365,200.00	100.00
Debt Service Fund or Fund	30 E 5140 6210 00 300 000004	0.00	0.00	0.00	0.00	0.00	0.00	0.00
Debt Service Fund or Fund	30 E 5140 6210 00 300 000005	322,000.00	161,000.00	0.00	0.00	161,000.00	161,000.00	50.00
Debt Service Fund or Fund	30 E 5140 6210 00 300 000006	77,800.00	0.00	0.00	0.00	38,900.00	38,900.00	50.00
Debt Service Fund or Fund	30 E 5140 6210 00 300 000007	840,550.00	0.00	0.00	0.00	840,550.00	0.00	0.00
Debt Service Fund or Fund	30 E 5200 6100 00 000 000000	0.00	0.00	0.00	0.00	0.00	0.00	0.00
Debt Service Fund or Fund	30 E 5200 6100 00 000 000001	0.00	0.00	0.00	0.00	0.00	0.00	0.00
Debt Service Fund or Fund	30 E 5200 6100 00 000 000002	0.00	0.00	0.00	0.00	0.00	0.00	0.00
Debt Service Fund or Fund	30 E 5200 6100 00 000 000003	0.00	0.00	0.00	0.00	0.00	0.00	0.00
Debt Service Fund or Fund	30 E 5200 6100 00 300 000000	0.00	0.00	0.00	0.00	0.00	0.00	0.00
Debt Service Fund or Fund	30 E 5200 6100 00 300 000001	0.00	0.00	0.00	0.00	0.00	0.00	281 0.00
Debt Service Fund or Fund	30 E 5200 6100 00 300 000002	0.00	0.00	0.00	0.00	0.00	0.00	0.00
Debt Service Fund or Fund	30 E 5200 6100 00 300 000003	0.00	0.00	0.00	0.00	0.00	0.00	0.00
Debt Service Fund or Fund	30 E 5200 6100 00 300 000004	0.00	0.00	0.00	0.00	0.00	0.00	0.00
Debt Service Fund or Fund	30 E 5200 6100 00 300 000005	0.00	0.00	0.00	0.00	0.00	0.00	0.00
Debt Service Fund or Fund	30 E 5200 6100 00 300 000006	0.00	0.00	0.00	0.00	0.00	0.00	0.00
Debt Service Fund or Fund	30 E 5200 6100 00 300 000007	0.00	0.00	0.00	0.00	0.00	0.00	0.00
Debt Service Fund or Fund	30 E 5200 6100 00 300 000008	0.00	0.00	0.00	0.00	0.00	0.00	0.00
Debt Service Fund or Fund	30 E 5200 6100 00 300 000009	2,285,000.00	0.00	0.00	0.00	2,285,000.00	0.00	0.00
Debt Service Fund or Fund	30 E 5200 6210 00 300 000000	0.00	0.00	0.00	0.00	0.00	0.00	0.00
Debt Service Fund or Fund	30 E 5300 6100 00 300 000000	0.00	0.00	0.00	0.00	-2,285,000.00	2,285,000.00	0.00
Debt Service Fund or Fund	30 E 5300 6110 00 000 000000	0.00	0.00	0.00	0.00	0.00	0.00	0.00
Debt Service Fund or Fund	30 E 5300 6110 00 000 000001	0.00	0.00	0.00	0.00	0.00	0.00	0.00
Debt Service Fund or Fund	30 E 5300 6110 00 000 000002	0.00	0.00	0.00	0.00	0.00	0.00	0.00
Debt Service Fund or Fund	30 E 5300 6110 00 000 000003	0.00	0.00	0.00	0.00	0.00	0.00	0.00
Debt Service Fund or Fund	30 E 5300 6110 00 000 000004	0.00	0.00	0.00	0.00	0.00	0.00	0.00
Debt Service Fund or Fund	30 E 5300 6110 00 000 000005	0.00	0.00	0.00	0.00	0.00	0.00	0.00
Debt Service Fund or Fund	30 E 5300 6110 00 000 000006	615,000.00	615,000.00	0.00	0.00	0.00	615,000.00	100.00
Debt Service Fund or Fund	30 E 5300 6110 00 000 000007	0.00	0.00	0.00	0.00	0.00	0.00	0.00
Debt Service Fund or Fund	30 E 5300 6110 00 000 000008	750,000.00	0.00	0.00	0.00	0.00	750,000.00	100.00

Expenditure Report

Fiscal Year: 2020-2021
Month: March

COUNTY OF GRUNDY SCHOOL DIST 111

Fund Description	Account Number	Revised Budget	MTD Activity	Encumbrance	Pending Activity	Available Funds	Year to Date Activity	Percent of Budget Used
Debt Service Fund or Fund	30 E 5300 6110 00 000 000009	0.00	0.00	0.00	0.00	0.00	0.00	0.00
Debt Service Fund or Fund	30 E 5300 6110 00 000 000010	0.00	0.00	0.00	0.00	0.00	0.00	0.00
Debt Service Fund or Fund	30 E 5300 6110 00 000 000011	0.00	0.00	0.00	0.00	0.00	0.00	0.00
Debt Service Fund or Fund	30 E 5300 6110 00 000 000012	2,090,000.00	2,090,000.00	0.00	0.00	-161,000.00	2,251,000.00	107.70
Debt Service Fund or Fund	30 E 5300 6610 00 000 000000	0.00	0.00	0.00	0.00	0.00	0.00	0.00
Debt Service Fund or Fund	30 E 5300 6610 00 300 000000	0.00	0.00	0.00	0.00	0.00	0.00	0.00
Debt Service Fund or Fund	30 E 5300 6610 00 300 000001	0.00	0.00	0.00	0.00	0.00	0.00	0.00
Debt Service Fund or Fund	30 E 5300 6610 00 300 000002	0.00	0.00	0.00	0.00	0.00	0.00	0.00
Debt Service Fund or Fund	30 E 5300 6610 00 300 000003	0.00	0.00	0.00	0.00	0.00	0.00	0.00
Debt Service Fund or Fund	30 E 5300 6610 00 302 000000	0.00	0.00	0.00	0.00	0.00	0.00	0.00
Debt Service Fund or Fund	30 E 5300 6610 00 302 000001	0.00	0.00	0.00	0.00	0.00	0.00	0.00
Debt Service Fund or Fund	30 E 5900 3180 00 000 000000	0.00	0.00	0.00	0.00	0.00	0.00	0.00
Debt Service Fund or Fund	30 E 5900 3190 00 000 000000	0.00	0.00	0.00	0.00	0.00	0.00	0.00
Debt Service Fund or Fund	30 E 5900 3190 00 000 000001	0.00	0.00	0.00	0.00	0.00	0.00	0.00
Debt Service Fund or Fund	30 E 5900 3900 00 300 000000	0.00	450.00	0.00	1,050.00	-35,334.12	34,284.12	282 0.00
Debt Service Fund or Fund	30 E 5900 3900 00 300 000001	0.00	0.00	0.00	0.00	0.00	0.00	0.00
Debt Service Fund or Fund	30 E 5900 6110 00 000 000000	0.00	0.00	0.00	0.00	0.00	0.00	0.00
Debt Service Fund or Fund	30 E 8990 0000 00 000 000001	0.00	0.00	0.00	0.00	0.00	0.00	0.00
30 -	-----	7,985,991.50	3,354,308.25	0.00	1,050.00	417,790.88	7,567,150.62	
3-	-----	7,985,991.50	3,354,308.25	0.00	1,050.00	417,790.88	7,567,150.62	
Transportation Fund	40 E 1130 2220 00 000 000000	0.00	2,021.67	0.00	1,380.87	-26,754.54	25,373.67	0.00
Transportation Fund	40 E 1130 2230 00 000 000000	0.00	466.01	0.00	20.59	-3,975.23	3,954.64	0.00
Transportation Fund	40 E 2190 1100 00 300 000000	55,992.59	4,666.06	0.00	0.00	13,998.05	41,994.54	75.00
Transportation Fund	40 E 2190 2110 00 300 000000	0.00	0.00	0.00	0.00	0.00	0.00	0.00
Transportation Fund	40 E 2190 2210 00 300 000000	0.00	0.00	0.00	0.00	0.00	0.00	0.00
Transportation Fund	40 E 2190 2220 00 300 000000	8,863.34	745.56	0.00	0.00	2,612.66	6,250.68	70.52
Transportation Fund	40 E 2190 2230 00 300 000000	0.00	39.12	0.00	0.00	-117.36	117.36	0.00
Transportation Fund	40 E 2190 3320 00 300 000000	0.00	0.00	0.00	0.00	0.00	0.00	0.00
Transportation Fund	40 E 2190 6400 00 300 000000	0.00	0.00	0.00	0.00	0.00	0.00	0.00
Transportation Fund	40 E 2220 0000 00 000 000000	0.00	0.00	0.00	0.00	0.00	0.00	0.00
Transportation Fund	40 E 2220 1100 00 300 000004	0.00	0.00	0.00	0.00	0.00	0.00	0.00

Expenditure Report

Fiscal Year: 2020-2021
Month: March

COUNTY OF GRUNDY SCHOOL DIST 111

Fund Description	Account Number	Revised Budget	MTD Activity	Encumbrance	Pending Activity	Available Funds	Year to Date Activity	Percent of Budget Used
Transportation Fund	40 E 2230 0000 00 000 000000	0.00	0.00	0.00	0.00	0.00	0.00	0.00
Transportation Fund	40 E 2310 2000 00 300 000000	0.00	0.00	0.00	0.00	0.00	0.00	0.00
Transportation Fund	40 E 2550 1100 00 300 000000	60,823.34	2,940.32	0.00	5,972.29	10,025.31	44,825.74	73.70
Transportation Fund	40 E 2550 1100 00 300 000001	0.00	0.00	0.00	0.00	0.00	0.00	0.00
Transportation Fund	40 E 2550 1100 00 300 000002	411,995.09	29,536.51	0.00	0.00	139,365.66	272,629.43	66.17
Transportation Fund	40 E 2550 1100 00 300 000003	530,000.00	34,993.83	0.00	0.00	204,924.57	325,075.43	61.33
Transportation Fund	40 E 2550 1100 00 300 000004	8,500.00	525.00	0.00	0.00	3,775.00	4,725.00	55.59
Transportation Fund	40 E 2550 1100 00 300 000005	124,000.00	6,594.21	0.00	0.00	67,482.80	56,517.20	45.58
Transportation Fund	40 E 2550 1100 00 300 000006	0.00	0.00	0.00	0.00	0.00	0.00	0.00
Transportation Fund	40 E 2550 1100 00 300 000007	0.00	0.00	0.00	0.00	0.00	0.00	0.00
Transportation Fund	40 E 2550 1100 00 300 000008	0.00	0.00	0.00	0.00	0.00	0.00	0.00
Transportation Fund	40 E 2550 1100 00 300 000009	65,000.00	4,139.78	0.00	0.00	29,059.89	35,940.11	55.29
Transportation Fund	40 E 2550 1300 00 300 000000	12,000.00	3,514.01	0.00	0.00	19.12	11,980.88	99.84
Transportation Fund	40 E 2550 1300 00 300 000001	50,000.00	613.10	0.00	0.00	45,631.06	4,368.94	8.74
Transportation Fund	40 E 2550 1300 00 300 000002	40,000.00	4,499.25	0.00	0.00	33,009.70	6,990.30	17.48
Transportation Fund	40 E 2550 1300 00 300 000003	0.00	0.00	0.00	0.00	0.00	0.00	0.00
Transportation Fund	40 E 2550 2220 00 000 000000	600.00	0.00	0.00	-0.52	325.90	274.62	45.77
Transportation Fund	40 E 2550 2220 00 000 000001	8,000.00	0.00	0.00	-0.52	8,030.82	-30.30	-0.38
Transportation Fund	40 E 2550 2220 00 300 000000	1,600.00	2,824.96	0.00	0.00	-2,644.96	4,244.96	265.31
Transportation Fund	40 E 2550 2220 00 300 000004	0.00	71.00	0.00	0.00	-593.88	593.88	0.00
Transportation Fund	40 E 2550 2220 00 300 000009	0.00	696.94	0.00	0.00	-2,725.56	2,725.56	0.00
Transportation Fund	40 E 2550 2230 00 300 000000	0.00	73.60	0.00	0.00	-147.20	147.20	0.00
Transportation Fund	40 E 2550 2230 00 300 000004	0.00	3.68	0.00	0.00	-11.04	11.04	0.00
Transportation Fund	40 E 2550 2300 00 300 000000	0.00	0.00	0.00	0.00	0.00	0.00	0.00
Transportation Fund	40 E 2550 3100 00 300 000000	12,000.00	0.00	0.00	0.00	10,765.00	1,235.00	10.29
Transportation Fund	40 E 2550 3100 00 300 000001	0.00	0.00	0.00	0.00	0.00	0.00	0.00
Transportation Fund	40 E 2550 3200 00 000 000000	550,000.00	0.00	0.00	0.00	489,359.69	60,640.31	11.03
Transportation Fund	40 E 2550 3210 00 300 000000	5,500.00	500.64	0.00	0.00	2,159.89	3,340.11	60.73
Transportation Fund	40 E 2550 3220 00 300 000000	5,000.00	0.00	0.00	0.00	4,421.46	578.54	11.57
Transportation Fund	40 E 2550 3220 00 300 000001	11,000.00	4,203.75	0.00	0.00	6,796.25	4,203.75	38.22
Transportation Fund	40 E 2550 3310 00 300 000000	65,000.00	0.00	0.00	0.00	60,164.84	4,835.16	7.44
Transportation Fund	40 E 2550 3320 00 300 000000	2,500.00	0.00	0.00	0.00	2,500.00	0.00	0.00
Transportation Fund	40 E 2550 3400 00 300 000000	2,500.00	47.65	0.00	0.00	1,794.54	705.46	28.22

Expenditure Report

Fiscal Year: 2020-2021
Month: March

COUNTY OF GRUNDY SCHOOL DIST 111

Fund Description	Account Number	Revised Budget	MTD Activity	Encumbrance	Pending Activity	Available Funds	Year to Date Activity	Percent of Budget Used
Transportation Fund	40 E 2550 3400 00 300 000001	0.00	0.00	0.00	0.00	0.00	0.00	0.00
Transportation Fund	40 E 2550 3500 00 000 000000	500.00	-944.47	0.00	0.00	-444.47	944.47	188.89
Transportation Fund	40 E 2550 3700 00 300 000000	2,500.00	0.00	0.00	63.02	2,048.87	388.11	15.52
Transportation Fund	40 E 2550 3800 00 300 000000	0.00	0.00	0.00	0.00	0.00	0.00	0.00
Transportation Fund	40 E 2550 3800 00 300 000001	0.00	0.00	0.00	0.00	0.00	0.00	0.00
Transportation Fund	40 E 2550 3800 00 300 000002	0.00	0.00	0.00	0.00	0.00	0.00	0.00
Transportation Fund	40 E 2550 3900 00 300 000000	0.00	0.00	0.00	0.00	0.00	0.00	0.00
Transportation Fund	40 E 2550 3900 00 300 000001	4,000.00	0.00	0.00	0.00	-5,969.78	9,969.78	249.24
Transportation Fund	40 E 2550 4640 00 300 000000	35,000.00	1,093.15	0.00	955.22	26,826.36	7,218.42	20.62
Transportation Fund	40 E 2550 6400 00 000 000000	600.00	0.00	0.00	0.00	600.00	0.00	0.00
Transportation Fund	40 E 2550 6900 00 300 000000	0.00	0.00	0.00	0.00	0.00	0.00	0.00
Transportation Fund	40 E 2552 4100 00 300 000000	60,000.00	497.37	0.00	52.50	45,008.24	14,939.26	24.90
Transportation Fund	40 E 2552 4100 00 300 000001	15,000.00	0.00	0.00	14.97	12,461.73	2,523.30	16.82
Transportation Fund	40 E 2552 4640 00 300 000000	175,000.00	14,627.96	0.00	14,710.69	116,241.80	44,047.51	28425.17
Transportation Fund	40 E 2552 4650 00 300 000000	2,200.00	219.82	0.00	0.00	1,307.00	893.00	40.59
Transportation Fund	40 E 2552 4660 00 300 000000	7,500.00	611.06	0.00	0.00	2,999.18	4,500.82	60.01
Transportation Fund	40 E 2554 1100 00 300 000000	106,803.12	7,797.32	0.00	0.00	53,730.99	53,072.13	49.69
Transportation Fund	40 E 2554 1100 00 300 000001	72,000.00	5,953.50	0.00	0.00	44,784.00	27,216.00	37.80
Transportation Fund	40 E 2554 2220 00 300 000000	69,000.00	3,906.44	0.00	570.55	43,658.87	24,770.58	35.90
Transportation Fund	40 E 2554 2220 00 300 000001	0.00	1,486.14	0.00	0.00	-12,508.02	12,508.02	0.00
Transportation Fund	40 E 2554 2230 00 300 000000	0.00	73.60	0.00	0.00	-220.80	220.80	0.00
Transportation Fund	40 E 2554 2230 00 300 000001	0.00	36.80	0.00	0.00	-110.40	110.40	0.00
Transportation Fund	40 E 2554 3000 00 300 000000	45,000.00	1,747.18	0.00	0.00	40,528.14	4,471.86	9.94
Transportation Fund	40 E 2554 3230 00 300 000000	70,000.00	9,244.06	0.00	6,196.23	-8,916.21	72,719.98	103.89
Transportation Fund	40 E 2554 3390 00 300 000000	10,000.00	0.00	0.00	585.00	2,727.51	6,687.49	66.87
Transportation Fund	40 E 2554 5400 00 300 000000	5,000.00	0.00	0.00	0.00	5,000.00	0.00	0.00
Transportation Fund	40 E 2554 5600 00 300 000000	30,000.00	0.00	0.00	0.00	30,000.00	0.00	0.00
Transportation Fund	40 E 2559 5200 00 300 000000	0.00	0.00	0.00	0.00	0.00	0.00	0.00
Transportation Fund	40 E 2559 5300 00 300 000000	10,000.00	0.00	0.00	0.00	2,389.72	7,610.28	76.10
Transportation Fund	40 E 2559 6900 00 300 000000	0.00	0.00	0.00	0.00	0.00	0.00	0.00
Transportation Fund	40 E 4810 2220 00 454 000000	0.00	0.00	0.00	0.00	0.00	0.00	0.00
Transportation Fund	40 E 4810 2220 00 454 000001	0.00	0.00	0.00	0.00	0.00	0.00	0.00

Expenditure Report

Fiscal Year: 2020-2021
Month: March

COUNTY OF GRUNDY SCHOOL DIST 111

Fund Description	Account Number	Revised Budget	MTD Activity	Encumbrance	Pending Activity	Available Funds	Year to Date Activity	Percent of Budget Used
40 - - - - -		2,750,977.48	150,066.58	0.00	30,520.89	1,501,395.17	1,219,061.42	
4- - - - -		2,750,977.48	150,066.58	0.00	30,520.89	1,501,395.17	1,219,061.42	
I.M.R.F./Soc. Sec. Fund	50 E 1130 2120 00 000 000000	6,370.72	565.56	0.00	0.00	2,397.19	3,973.53	62.37
I.M.R.F./Soc. Sec. Fund	50 E 1130 2120 00 300 000000	189.11	0.00	0.00	0.00	189.11	0.00	0.00
I.M.R.F./Soc. Sec. Fund	50 E 1130 2120 00 300 000001	0.00	0.00	0.00	0.00	-244.65	244.65	0.00
I.M.R.F./Soc. Sec. Fund	50 E 1130 2120 50 300 000000	0.00	0.00	0.00	0.00	0.00	0.00	0.00
I.M.R.F./Soc. Sec. Fund	50 E 1130 2130 00 000 000000	5,076.80	342.10	0.00	0.00	2,640.24	2,436.56	47.99
I.M.R.F./Soc. Sec. Fund	50 E 1130 2130 00 300 000000	234.50	0.00	0.00	0.00	234.50	0.00	0.00
I.M.R.F./Soc. Sec. Fund	50 E 1130 2130 00 300 000001	0.00	0.00	0.00	0.00	-151.38	151.38	0.00
I.M.R.F./Soc. Sec. Fund	50 E 1130 2130 00 300 000004	0.00	0.00	0.00	0.00	-1,469.00	1,469.00	0.00
I.M.R.F./Soc. Sec. Fund	50 E 1130 2130 05 300 000000	0.00	0.00	0.00	0.00	0.00	0.00	0.00
I.M.R.F./Soc. Sec. Fund	50 E 1130 2130 12 300 000000	0.00	0.00	0.00	0.00	0.00	0.00	0.00
I.M.R.F./Soc. Sec. Fund	50 E 1130 2130 21 300 000000	0.00	0.00	0.00	0.00	0.00	0.00	0.00
I.M.R.F./Soc. Sec. Fund	50 E 1130 2130 27 300 000000	0.00	0.00	0.00	0.00	0.00	0.00	0.00
I.M.R.F./Soc. Sec. Fund	50 E 1130 2130 50 300 000000	0.00	0.00	0.00	0.00	0.00	0.00	0.00
I.M.R.F./Soc. Sec. Fund	50 E 1130 2140 00 000 000000	0.00	80.00	0.00	0.00	-572.22	572.22	0.00
I.M.R.F./Soc. Sec. Fund	50 E 1130 2140 00 300 000000	8,695.94	117.14	0.00	0.00	7,634.42	1,061.52	12.21
I.M.R.F./Soc. Sec. Fund	50 E 1130 2140 00 300 000001	0.00	900.74	0.00	0.00	-4,865.06	4,865.06	0.00
I.M.R.F./Soc. Sec. Fund	50 E 1130 2140 00 300 000002	0.00	0.00	0.00	0.00	-159.28	159.28	0.00
I.M.R.F./Soc. Sec. Fund	50 E 1130 2140 00 300 000003	0.00	0.00	0.00	0.00	-59.51	59.51	0.00
I.M.R.F./Soc. Sec. Fund	50 E 1130 2140 00 300 000004	0.00	0.00	0.00	0.00	-2,016.61	2,016.61	0.00
I.M.R.F./Soc. Sec. Fund	50 E 1130 2140 02 300 000000	2,459.23	204.48	0.00	0.00	617.87	1,841.36	74.88
I.M.R.F./Soc. Sec. Fund	50 E 1130 2140 05 300 000000	22,653.61	1,777.17	0.00	0.00	6,664.04	15,989.57	70.58
I.M.R.F./Soc. Sec. Fund	50 E 1130 2140 06 300 000000	9,368.95	866.11	0.00	0.00	1,707.08	7,661.87	81.78
I.M.R.F./Soc. Sec. Fund	50 E 1130 2140 11 300 000000	18,681.63	1,618.03	0.00	0.00	4,252.88	14,428.75	77.23
I.M.R.F./Soc. Sec. Fund	50 E 1130 2140 12 300 000000	3,777.45	322.49	0.00	0.00	899.79	2,877.66	76.18
I.M.R.F./Soc. Sec. Fund	50 E 1130 2140 13 300 000000	18,561.54	1,557.31	0.00	0.00	4,502.44	14,059.10	75.74
I.M.R.F./Soc. Sec. Fund	50 E 1130 2140 15 300 000000	17,852.47	1,469.79	0.00	0.00	4,658.58	13,193.89	73.91
I.M.R.F./Soc. Sec. Fund	50 E 1130 2140 21 300 000000	0.00	0.00	0.00	0.00	0.00	0.00	0.00
I.M.R.F./Soc. Sec. Fund	50 E 1130 2140 27 300 000000	8,007.64	756.68	0.00	0.00	1,295.00	6,712.64	83.83
I.M.R.F./Soc. Sec. Fund	50 E 1130 2140 50 300 000000	15,384.14	1,277.19	0.00	0.00	3,886.52	11,497.62	74.74

285

Expenditure Report

Fiscal Year: 2020-2021
Month: March

COUNTY OF GRUNDY SCHOOL DIST 111

Fund Description	Account Number	Revised Budget	MTD Activity	Encumbrance	Pending Activity	Available Funds	Year to Date Activity	Percent of Budget Used
I.M.R.F./Soc. Sec. Fund	50 E 1200 2120 00 300 000000	14,724.18	0.00	0.00	0.00	14,724.18	0.00	0.00
I.M.R.F./Soc. Sec. Fund	50 E 1200 2120 00 300 000001	0.00	0.00	0.00	0.00	0.00	0.00	0.00
I.M.R.F./Soc. Sec. Fund	50 E 1200 2120 00 300 000002	0.00	975.62	0.00	0.00	-8,448.90	8,448.90	0.00
I.M.R.F./Soc. Sec. Fund	50 E 1200 2120 00 300 000003	0.00	308.48	0.00	0.00	-2,730.63	2,730.63	0.00
I.M.R.F./Soc. Sec. Fund	50 E 1200 2130 00 300 000000	11,594.61	0.00	0.00	0.00	11,594.61	0.00	0.00
I.M.R.F./Soc. Sec. Fund	50 E 1200 2130 00 300 000001	0.00	0.00	0.00	0.00	0.00	0.00	0.00
I.M.R.F./Soc. Sec. Fund	50 E 1200 2130 00 300 000002	0.00	582.36	0.00	0.00	-5,117.02	5,117.02	0.00
I.M.R.F./Soc. Sec. Fund	50 E 1200 2130 00 300 000003	0.00	180.38	0.00	0.00	-1,639.31	1,639.31	0.00
I.M.R.F./Soc. Sec. Fund	50 E 1200 2140 00 300 000000	14,712.10	1,291.75	0.00	0.00	3,226.31	11,485.79	78.07
I.M.R.F./Soc. Sec. Fund	50 E 1200 2140 00 300 000001	0.00	0.00	0.00	0.00	0.00	0.00	0.00
I.M.R.F./Soc. Sec. Fund	50 E 1200 2140 00 300 000002	0.00	136.22	0.00	0.00	-1,202.02	1,202.02	0.00
I.M.R.F./Soc. Sec. Fund	50 E 1200 2140 00 300 000003	0.00	42.18	0.00	0.00	-385.18	385.18	0.00
I.M.R.F./Soc. Sec. Fund	50 E 1250 2120 00 300 000000	0.00	0.00	0.00	0.00	0.00	0.00	0.00
I.M.R.F./Soc. Sec. Fund	50 E 1250 2130 00 300 000000	0.00	0.00	0.00	0.00	0.00	0.00	286 0.00
I.M.R.F./Soc. Sec. Fund	50 E 1250 2140 00 300 000000	0.00	0.00	0.00	0.00	0.00	0.00	0.00
I.M.R.F./Soc. Sec. Fund	50 E 1400 2120 00 300 000000	22.32	0.00	0.00	0.00	22.32	0.00	0.00
I.M.R.F./Soc. Sec. Fund	50 E 1400 2130 00 300 000000	18.70	0.00	0.00	0.00	18.70	0.00	0.00
I.M.R.F./Soc. Sec. Fund	50 E 1400 2140 00 300 000000	3,550.87	267.54	0.00	0.00	1,127.96	2,422.91	68.23
I.M.R.F./Soc. Sec. Fund	50 E 1400 2140 10 300 000000	1,661.10	201.74	0.00	0.00	-59.68	1,720.78	103.59
I.M.R.F./Soc. Sec. Fund	50 E 1401 2140 01 300 000000	3,066.06	255.78	0.00	0.00	778.28	2,287.78	74.62
I.M.R.F./Soc. Sec. Fund	50 E 1407 2140 03 300 000000	3,514.88	248.76	0.00	0.00	1,209.49	2,305.39	65.59
I.M.R.F./Soc. Sec. Fund	50 E 1410 2140 00 300 000000	0.00	0.00	0.00	0.00	0.00	0.00	0.00
I.M.R.F./Soc. Sec. Fund	50 E 1411 2140 00 300 000000	1,088.63	90.32	0.00	0.00	278.50	810.13	74.42
I.M.R.F./Soc. Sec. Fund	50 E 1417 2120 00 300 000000	5,142.13	612.47	0.00	0.00	869.40	4,272.73	83.09
I.M.R.F./Soc. Sec. Fund	50 E 1417 2130 00 300 000000	4,027.44	364.82	0.00	0.00	1,453.49	2,573.95	63.91
I.M.R.F./Soc. Sec. Fund	50 E 1417 2140 00 300 000000	0.00	85.33	0.00	0.00	-604.60	604.60	0.00
I.M.R.F./Soc. Sec. Fund	50 E 1420 2140 09 300 000000	2,855.40	166.78	0.00	0.00	1,021.58	1,833.82	64.22
I.M.R.F./Soc. Sec. Fund	50 E 1500 2120 00 000 000000	0.00	0.00	0.00	0.00	0.00	0.00	0.00
I.M.R.F./Soc. Sec. Fund	50 E 1500 2120 30 300 000000	0.00	0.00	0.00	0.00	0.00	0.00	0.00
I.M.R.F./Soc. Sec. Fund	50 E 1500 2120 30 300 000001	7,144.54	404.86	0.00	0.00	3,560.77	3,583.77	50.16
I.M.R.F./Soc. Sec. Fund	50 E 1500 2120 30 300 000002	0.00	368.44	0.00	0.00	-458.74	458.74	0.00
I.M.R.F./Soc. Sec. Fund	50 E 1500 2120 30 300 000015	0.00	40.50	0.00	0.00	-358.55	358.55	0.00
I.M.R.F./Soc. Sec. Fund	50 E 1500 2120 70 300 000000	5,453.75	0.00	0.00	0.00	5,453.75	0.00	0.00

Expenditure Report

Fiscal Year: 2020-2021
Month: March

COUNTY OF GRUNDY SCHOOL DIST 111

Fund Description	Account Number	Revised Budget	MTD Activity	Encumbrance	Pending Activity	Available Funds	Year to Date Activity	Percent of Budget Used
I.M.R.F./Soc. Sec. Fund	50 E 1500 2120 70 300 000001	0.00	387.75	0.00	0.00	-3,545.33	3,545.33	0.00
I.M.R.F./Soc. Sec. Fund	50 E 1500 2120 70 300 000003	0.00	68.39	0.00	0.00	-152.30	152.30	0.00
I.M.R.F./Soc. Sec. Fund	50 E 1500 2120 70 300 000006	0.00	18.32	0.00	0.00	-117.61	117.61	0.00
I.M.R.F./Soc. Sec. Fund	50 E 1500 2120 70 300 000046	0.00	24.42	0.00	0.00	-180.72	180.72	0.00
I.M.R.F./Soc. Sec. Fund	50 E 1500 2120 70 300 000049	0.00	28.06	0.00	0.00	-180.15	180.15	0.00
I.M.R.F./Soc. Sec. Fund	50 E 1500 2120 70 300 000051	0.00	0.00	0.00	0.00	-321.49	321.49	0.00
I.M.R.F./Soc. Sec. Fund	50 E 1500 2130 00 000 000000	0.00	0.00	0.00	0.00	0.00	0.00	0.00
I.M.R.F./Soc. Sec. Fund	50 E 1500 2130 30 300 000000	13,528.94	0.00	0.00	0.00	13,528.94	0.00	0.00
I.M.R.F./Soc. Sec. Fund	50 E 1500 2130 30 300 000001	0.00	221.50	0.00	0.00	-1,991.30	1,991.30	0.00
I.M.R.F./Soc. Sec. Fund	50 E 1500 2130 30 300 000002	0.00	222.86	0.00	0.00	-277.89	277.89	0.00
I.M.R.F./Soc. Sec. Fund	50 E 1500 2130 30 300 000006	0.00	0.00	0.00	0.00	-147.13	147.13	0.00
I.M.R.F./Soc. Sec. Fund	50 E 1500 2130 30 300 000010	0.00	0.00	0.00	0.00	-485.54	485.54	0.00
I.M.R.F./Soc. Sec. Fund	50 E 1500 2130 30 300 000012	0.00	147.13	0.00	0.00	-294.26	294.26	0.00
I.M.R.F./Soc. Sec. Fund	50 E 1500 2130 30 300 000013	0.00	0.00	0.00	0.00	-547.83	547.83	0.00
I.M.R.F./Soc. Sec. Fund	50 E 1500 2130 30 300 000015	0.00	24.50	0.00	0.00	-220.14	220.14	0.00
I.M.R.F./Soc. Sec. Fund	50 E 1500 2130 30 300 000016	0.00	406.22	0.00	0.00	-812.44	812.44	0.00
I.M.R.F./Soc. Sec. Fund	50 E 1500 2130 30 300 000018	0.00	147.13	0.00	0.00	-294.26	294.26	0.00
I.M.R.F./Soc. Sec. Fund	50 E 1500 2130 30 300 000019	0.00	123.01	0.00	0.00	-246.02	246.02	0.00
I.M.R.F./Soc. Sec. Fund	50 E 1500 2130 70 300 000000	5,997.63	0.00	0.00	0.00	5,997.63	0.00	0.00
I.M.R.F./Soc. Sec. Fund	50 E 1500 2130 70 300 000001	0.00	216.50	0.00	0.00	-2,017.58	2,017.58	0.00
I.M.R.F./Soc. Sec. Fund	50 E 1500 2130 70 300 000003	0.00	41.37	0.00	0.00	-93.03	93.03	0.00
I.M.R.F./Soc. Sec. Fund	50 E 1500 2130 70 300 000006	0.00	11.08	0.00	0.00	-72.02	72.02	0.00
I.M.R.F./Soc. Sec. Fund	50 E 1500 2130 70 300 000039	0.00	0.00	0.00	0.00	-105.28	105.28	0.00
I.M.R.F./Soc. Sec. Fund	50 E 1500 2130 70 300 000046	0.00	14.78	0.00	0.00	-110.85	110.85	0.00
I.M.R.F./Soc. Sec. Fund	50 E 1500 2130 70 300 000049	0.00	16.96	0.00	0.00	-110.24	110.24	0.00
I.M.R.F./Soc. Sec. Fund	50 E 1500 2130 70 300 000051	0.00	0.00	0.00	0.00	-204.58	204.58	0.00
I.M.R.F./Soc. Sec. Fund	50 E 1500 2130 70 300 000054	0.00	0.00	0.00	0.00	-161.20	161.20	0.00
I.M.R.F./Soc. Sec. Fund	50 E 1500 2140 00 000 000000	0.00	0.00	0.00	0.00	0.00	0.00	0.00
I.M.R.F./Soc. Sec. Fund	50 E 1500 2140 00 300 000000	0.00	0.00	0.00	0.00	0.00	0.00	0.00
I.M.R.F./Soc. Sec. Fund	50 E 1500 2140 30 000 000000	0.00	0.00	0.00	0.00	0.00	0.00	0.00
I.M.R.F./Soc. Sec. Fund	50 E 1500 2140 30 300 000000	9,911.29	175.50	0.00	0.00	8,433.68	1,477.61	14.91
I.M.R.F./Soc. Sec. Fund	50 E 1500 2140 30 300 000001	0.00	68.44	0.00	0.00	-616.48	616.48	0.00
I.M.R.F./Soc. Sec. Fund	50 E 1500 2140 30 300 000002	0.00	162.20	0.00	0.00	-379.79	379.79	0.00

287

Expenditure Report

Fiscal Year: 2020-2021
Month: March

COUNTY OF GRUNDY SCHOOL DIST 111

Fund Description	Account Number	Revised Budget	MTD Activity	Encumbrance	Pending Activity	Available Funds	Year to Date Activity	Percent of Budget Used
I.M.R.F./Soc. Sec. Fund	50 E 1500 2140 30 300 000003	0.00	14.42	0.00	0.00	-130.16	130.16	0.00
I.M.R.F./Soc. Sec. Fund	50 E 1500 2140 30 300 000004	0.00	18.78	0.00	0.00	-180.49	180.49	0.00
I.M.R.F./Soc. Sec. Fund	50 E 1500 2140 30 300 000005	0.00	10.98	0.00	0.00	-90.29	90.29	0.00
I.M.R.F./Soc. Sec. Fund	50 E 1500 2140 30 300 000006	0.00	33.68	0.00	0.00	-309.59	309.59	0.00
I.M.R.F./Soc. Sec. Fund	50 E 1500 2140 30 300 000007	0.00	20.74	0.00	0.00	-185.77	185.77	0.00
I.M.R.F./Soc. Sec. Fund	50 E 1500 2140 30 300 000008	0.00	23.56	0.00	0.00	-287.55	287.55	0.00
I.M.R.F./Soc. Sec. Fund	50 E 1500 2140 30 300 000009	0.00	31.94	0.00	0.00	-282.57	282.57	0.00
I.M.R.F./Soc. Sec. Fund	50 E 1500 2140 30 300 000010	0.00	65.12	0.00	0.00	-695.71	695.71	0.00
I.M.R.F./Soc. Sec. Fund	50 E 1500 2140 30 300 000011	0.00	59.74	0.00	0.00	-536.89	536.89	0.00
I.M.R.F./Soc. Sec. Fund	50 E 1500 2140 30 300 000012	0.00	96.80	0.00	0.00	-353.00	353.00	0.00
I.M.R.F./Soc. Sec. Fund	50 E 1500 2140 30 300 000013	0.00	23.22	0.00	0.00	-352.79	352.79	0.00
I.M.R.F./Soc. Sec. Fund	50 E 1500 2140 30 300 000014	0.00	10.98	0.00	0.00	-103.96	103.96	0.00
I.M.R.F./Soc. Sec. Fund	50 E 1500 2140 30 300 000015	0.00	26.17	0.00	0.00	-234.62	234.62	0.00
I.M.R.F./Soc. Sec. Fund	50 E 1500 2140 30 300 000016	0.00	95.00	0.00	0.00	-190.00	190.00	0.00
I.M.R.F./Soc. Sec. Fund	50 E 1500 2140 30 300 000017	0.00	57.42	0.00	0.00	-294.90	294.90	0.00
I.M.R.F./Soc. Sec. Fund	50 E 1500 2140 30 300 000018	0.00	64.49	0.00	0.00	-342.09	342.09	0.00
I.M.R.F./Soc. Sec. Fund	50 E 1500 2140 30 300 000019	0.00	37.19	0.00	0.00	-133.54	133.54	0.00
I.M.R.F./Soc. Sec. Fund	50 E 1500 2140 30 300 000020	0.00	10.26	0.00	0.00	-84.54	84.54	0.00
I.M.R.F./Soc. Sec. Fund	50 E 1500 2140 30 300 000021	0.00	35.92	0.00	0.00	-298.75	298.75	0.00
I.M.R.F./Soc. Sec. Fund	50 E 1500 2140 30 300 000022	0.00	24.98	0.00	0.00	-232.56	232.56	0.00
I.M.R.F./Soc. Sec. Fund	50 E 1500 2140 70 300 000000	4,562.10	111.44	0.00	0.00	3,561.92	1,000.18	21.92
I.M.R.F./Soc. Sec. Fund	50 E 1500 2140 70 300 000001	0.00	50.63	0.00	0.00	-515.86	515.86	0.00
I.M.R.F./Soc. Sec. Fund	50 E 1500 2140 70 300 000002	0.00	25.82	0.00	0.00	-227.07	227.07	0.00
I.M.R.F./Soc. Sec. Fund	50 E 1500 2140 70 300 000003	0.00	12.80	0.00	0.00	-48.50	48.50	0.00
I.M.R.F./Soc. Sec. Fund	50 E 1500 2140 70 300 000004	0.00	5.70	0.00	0.00	-51.45	51.45	0.00
I.M.R.F./Soc. Sec. Fund	50 E 1500 2140 70 300 000005	0.00	14.02	0.00	0.00	-123.14	123.14	0.00
I.M.R.F./Soc. Sec. Fund	50 E 1500 2140 70 300 000006	0.00	6.38	0.00	0.00	-54.76	54.76	0.00
I.M.R.F./Soc. Sec. Fund	50 E 1500 2140 70 300 000008	0.00	2.66	0.00	0.00	-24.01	24.01	0.00
I.M.R.F./Soc. Sec. Fund	50 E 1500 2140 70 300 000009	0.00	24.24	0.00	0.00	-217.74	217.74	0.00
I.M.R.F./Soc. Sec. Fund	50 E 1500 2140 70 300 000010	0.00	11.32	0.00	0.00	-102.09	102.09	0.00
I.M.R.F./Soc. Sec. Fund	50 E 1500 2140 70 300 000011	0.00	14.74	0.00	0.00	-131.71	131.71	0.00
I.M.R.F./Soc. Sec. Fund	50 E 1500 2140 70 300 000012	0.00	6.18	0.00	0.00	-55.78	55.78	0.00
I.M.R.F./Soc. Sec. Fund	50 E 1500 2140 70 300 000013	0.00	9.40	0.00	0.00	-84.29	84.29	0.00

288

Expenditure Report

Fiscal Year: 2020-2021
Month: March

COUNTY OF GRUNDY SCHOOL DIST 111

Fund Description	Account Number	Revised Budget	MTD Activity	Encumbrance	Pending Activity	Available Funds	Year to Date Activity	Percent of Budget Used
I.M.R.F./Soc. Sec. Fund	50 E 1500 2140 70 300 000015	0.00	14.06	0.00	0.00	-126.91	126.91	0.00
I.M.R.F./Soc. Sec. Fund	50 E 1500 2140 70 300 000016	0.00	2.54	0.00	0.00	-22.90	22.90	0.00
I.M.R.F./Soc. Sec. Fund	50 E 1500 2140 70 300 000017	0.00	3.80	0.00	0.00	-33.90	33.90	0.00
I.M.R.F./Soc. Sec. Fund	50 E 1500 2140 70 300 000018	0.00	2.80	0.00	0.00	-24.85	24.85	0.00
I.M.R.F./Soc. Sec. Fund	50 E 1500 2140 70 300 000021	0.00	8.78	0.00	0.00	-78.39	78.39	0.00
I.M.R.F./Soc. Sec. Fund	50 E 1500 2140 70 300 000022	0.00	2.54	0.00	0.00	-22.93	22.93	0.00
I.M.R.F./Soc. Sec. Fund	50 E 1500 2140 70 300 000023	0.00	8.18	0.00	0.00	-73.81	73.81	0.00
I.M.R.F./Soc. Sec. Fund	50 E 1500 2140 70 300 000025	0.00	2.46	0.00	0.00	-22.20	22.20	0.00
I.M.R.F./Soc. Sec. Fund	50 E 1500 2140 70 300 000026	0.00	12.92	0.00	0.00	-116.32	116.32	0.00
I.M.R.F./Soc. Sec. Fund	50 E 1500 2140 70 300 000027	0.00	6.26	0.00	0.00	-56.11	56.11	0.00
I.M.R.F./Soc. Sec. Fund	50 E 1500 2140 70 300 000029	0.00	2.06	0.00	0.00	-18.59	18.59	0.00
I.M.R.F./Soc. Sec. Fund	50 E 1500 2140 70 300 000030	0.00	3.30	0.00	0.00	-29.79	29.79	0.00
I.M.R.F./Soc. Sec. Fund	50 E 1500 2140 70 300 000031	0.00	3.28	0.00	0.00	-29.61	29.61	0.00
I.M.R.F./Soc. Sec. Fund	50 E 1500 2140 70 300 000032	0.00	7.08	0.00	0.00	-63.45	63.45	0.00
I.M.R.F./Soc. Sec. Fund	50 E 1500 2140 70 300 000033	0.00	3.28	0.00	0.00	-29.61	29.61	289 0.00
I.M.R.F./Soc. Sec. Fund	50 E 1500 2140 70 300 000034	0.00	2.54	0.00	0.00	-23.69	23.69	0.00
I.M.R.F./Soc. Sec. Fund	50 E 1500 2140 70 300 000035	0.00	4.56	0.00	0.00	-41.25	41.25	0.00
I.M.R.F./Soc. Sec. Fund	50 E 1500 2140 70 300 000036	0.00	3.32	0.00	0.00	-21.58	21.58	0.00
I.M.R.F./Soc. Sec. Fund	50 E 1500 2140 70 300 000038	0.00	2.06	0.00	0.00	-18.59	18.59	0.00
I.M.R.F./Soc. Sec. Fund	50 E 1500 2140 70 300 000039	0.00	0.00	0.00	0.00	-24.62	24.62	0.00
I.M.R.F./Soc. Sec. Fund	50 E 1500 2140 70 300 000042	0.00	2.46	0.00	0.00	-21.90	21.90	0.00
I.M.R.F./Soc. Sec. Fund	50 E 1500 2140 70 300 000043	0.00	3.46	0.00	0.00	-31.23	31.23	0.00
I.M.R.F./Soc. Sec. Fund	50 E 1500 2140 70 300 000046	0.00	9.76	0.00	0.00	-82.82	82.82	0.00
I.M.R.F./Soc. Sec. Fund	50 E 1500 2140 70 300 000047	0.00	2.46	0.00	0.00	-21.59	21.59	0.00
I.M.R.F./Soc. Sec. Fund	50 E 1500 2140 70 300 000049	0.00	6.50	0.00	0.00	-53.00	53.00	0.00
I.M.R.F./Soc. Sec. Fund	50 E 1500 2140 70 300 000050	0.00	2.78	0.00	0.00	-24.73	24.73	0.00
I.M.R.F./Soc. Sec. Fund	50 E 1500 2140 70 300 000051	0.00	0.00	0.00	0.00	-189.30	189.30	0.00
I.M.R.F./Soc. Sec. Fund	50 E 1500 2140 70 300 000053	0.00	3.04	0.00	0.00	-27.44	27.44	0.00
I.M.R.F./Soc. Sec. Fund	50 E 1500 2140 70 300 000054	0.00	0.00	0.00	0.00	-37.70	37.70	0.00
I.M.R.F./Soc. Sec. Fund	50 E 1600 2120 00 300 000000	0.00	0.00	0.00	0.00	0.00	0.00	0.00
I.M.R.F./Soc. Sec. Fund	50 E 1600 2130 00 300 000000	0.00	0.00	0.00	0.00	0.00	0.00	0.00
I.M.R.F./Soc. Sec. Fund	50 E 1600 2140 00 300 000000	0.00	0.00	0.00	0.00	0.00	0.00	0.00
I.M.R.F./Soc. Sec. Fund	50 E 1700 2120 00 300 000000	0.00	0.00	0.00	0.00	0.00	0.00	0.00

Expenditure Report

Fiscal Year: 2020-2021
Month: March

COUNTY OF GRUNDY SCHOOL DIST 111

Fund Description	Account Number	Revised Budget	MTD Activity	Encumbrance	Pending Activity	Available Funds	Year to Date Activity	Percent of Budget Used
I.M.R.F./Soc. Sec. Fund	50 E 1700 2130 00 300 000000	0.00	0.00	0.00	0.00	0.00	0.00	0.00
I.M.R.F./Soc. Sec. Fund	50 E 1700 2140 00 300 000000	117.93	0.00	0.00	0.00	-62.12	180.05	152.68
I.M.R.F./Soc. Sec. Fund	50 E 1700 2140 21 300 000000	9,423.39	472.66	0.00	0.00	5,482.04	3,941.35	41.83
I.M.R.F./Soc. Sec. Fund	50 E 1900 2120 00 301 000000	0.00	0.00	0.00	0.00	0.00	0.00	0.00
I.M.R.F./Soc. Sec. Fund	50 E 1900 2120 00 301 000001	3,051.89	273.38	0.00	0.00	647.31	2,404.58	78.79
I.M.R.F./Soc. Sec. Fund	50 E 1900 2130 00 301 000000	0.00	0.00	0.00	0.00	0.00	0.00	0.00
I.M.R.F./Soc. Sec. Fund	50 E 1900 2130 00 301 000001	2,308.32	146.12	0.00	0.00	1,004.88	1,303.44	56.47
I.M.R.F./Soc. Sec. Fund	50 E 1900 2140 00 301 000000	0.00	115.24	0.00	0.00	-1,018.76	1,018.76	0.00
I.M.R.F./Soc. Sec. Fund	50 E 1900 2140 00 301 000001	1,262.54	34.18	0.00	0.00	956.31	306.23	24.26
I.M.R.F./Soc. Sec. Fund	50 E 2100 2120 00 300 000000	0.00	0.00	0.00	0.00	0.00	0.00	0.00
I.M.R.F./Soc. Sec. Fund	50 E 2100 2120 00 300 000001	4,194.85	348.38	0.00	0.00	850.69	3,344.16	79.72
I.M.R.F./Soc. Sec. Fund	50 E 2100 2120 00 301 000000	0.00	0.00	0.00	0.00	0.00	0.00	0.00
I.M.R.F./Soc. Sec. Fund	50 E 2100 2120 00 302 000000	0.00	0.00	0.00	0.00	0.00	0.00	0.00
I.M.R.F./Soc. Sec. Fund	50 E 2100 2130 00 300 000000	0.00	0.00	0.00	0.00	0.00	0.00	0.00
I.M.R.F./Soc. Sec. Fund	50 E 2100 2130 00 300 000001	3,356.66	210.72	0.00	0.00	1,302.25	2,054.41	61.20
I.M.R.F./Soc. Sec. Fund	50 E 2100 2130 00 301 000000	0.00	0.00	0.00	0.00	0.00	0.00	0.00
I.M.R.F./Soc. Sec. Fund	50 E 2100 2130 00 302 000000	0.00	0.00	0.00	0.00	0.00	0.00	0.00
I.M.R.F./Soc. Sec. Fund	50 E 2100 2140 00 300 000000	0.00	0.00	0.00	0.00	0.00	0.00	0.00
I.M.R.F./Soc. Sec. Fund	50 E 2100 2140 00 300 000001	0.00	49.28	0.00	0.00	-483.63	483.63	0.00
I.M.R.F./Soc. Sec. Fund	50 E 2100 2140 00 302 000000	1,823.19	172.85	0.00	0.00	281.16	1,542.03	84.58
I.M.R.F./Soc. Sec. Fund	50 E 2100 2140 00 302 000001	0.00	0.00	0.00	0.00	0.00	0.00	0.00
I.M.R.F./Soc. Sec. Fund	50 E 2110 2120 00 000 000000	2,279.38	185.66	0.00	0.00	690.13	1,589.25	69.72
I.M.R.F./Soc. Sec. Fund	50 E 2110 2130 00 000 000000	1,823.36	112.30	0.00	0.00	847.83	975.53	53.50
I.M.R.F./Soc. Sec. Fund	50 E 2110 2140 00 000 000000	349.76	49.12	0.00	0.00	-94.71	444.47	127.08
I.M.R.F./Soc. Sec. Fund	50 E 2113 2140 00 300 000000	2,867.38	249.70	0.00	0.00	633.37	2,234.01	77.91
I.M.R.F./Soc. Sec. Fund	50 E 2120 0000 00 000 000000	0.00	0.00	0.00	0.00	0.00	0.00	0.00
I.M.R.F./Soc. Sec. Fund	50 E 2120 1100 00 300 000000	0.00	0.00	0.00	0.00	0.00	0.00	0.00
I.M.R.F./Soc. Sec. Fund	50 E 2120 1100 00 300 000004	0.00	0.00	0.00	0.00	0.00	0.00	0.00
I.M.R.F./Soc. Sec. Fund	50 E 2120 2120 00 300 000000	0.00	0.00	0.00	0.00	0.00	0.00	0.00
I.M.R.F./Soc. Sec. Fund	50 E 2120 2130 00 300 000000	0.00	0.00	0.00	0.00	0.00	0.00	0.00
I.M.R.F./Soc. Sec. Fund	50 E 2120 2140 00 300 000000	6,987.91	617.98	0.00	0.00	1,614.32	5,373.59	76.90
I.M.R.F./Soc. Sec. Fund	50 E 2125 2120 00 300 000000	10,934.08	685.50	0.00	0.00	4,866.13	6,067.95	55.50
I.M.R.F./Soc. Sec. Fund	50 E 2125 2120 00 300 000001	0.00	404.08	0.00	0.00	-3,510.30	3,510.30	0.00

290

Expenditure Report

Fiscal Year: 2020-2021
Month: March

COUNTY OF GRUNDY SCHOOL DIST 111

Fund Description	Account Number	Revised Budget	MTD Activity	Encumbrance	Pending Activity	Available Funds	Year to Date Activity	Percent of Budget Used
I.M.R.F./Soc. Sec. Fund	50 E 2125 2120 00 302 000000	3,936.41	345.46	0.00	0.00	717.79	3,218.62	81.77
I.M.R.F./Soc. Sec. Fund	50 E 2125 2130 00 300 000000	8,740.99	414.00	0.00	0.00	5,021.12	3,719.87	42.56
I.M.R.F./Soc. Sec. Fund	50 E 2125 2130 00 300 000001	0.00	241.60	0.00	0.00	-2,146.55	2,146.55	0.00
I.M.R.F./Soc. Sec. Fund	50 E 2125 2130 00 302 000000	2,739.28	181.62	0.00	0.00	1,042.73	1,696.55	61.93
I.M.R.F./Soc. Sec. Fund	50 E 2125 2140 00 300 000000	0.00	96.82	0.00	0.00	-873.93	873.93	0.00
I.M.R.F./Soc. Sec. Fund	50 E 2125 2140 00 300 000001	0.00	56.50	0.00	0.00	-504.02	504.02	0.00
I.M.R.F./Soc. Sec. Fund	50 E 2125 2140 00 302 000000	0.00	42.46	0.00	0.00	-398.73	398.73	0.00
I.M.R.F./Soc. Sec. Fund	50 E 2130 0000 00 000 000000	0.00	0.00	0.00	0.00	0.00	0.00	0.00
I.M.R.F./Soc. Sec. Fund	50 E 2130 1100 00 300 000000	0.00	0.00	0.00	0.00	0.00	0.00	0.00
I.M.R.F./Soc. Sec. Fund	50 E 2130 1100 00 300 000004	0.00	0.00	0.00	0.00	0.00	0.00	0.00
I.M.R.F./Soc. Sec. Fund	50 E 2134 2120 00 300 000000	3,891.84	571.32	0.00	0.00	518.78	3,373.06	86.67
I.M.R.F./Soc. Sec. Fund	50 E 2134 2120 00 302 000000	3,616.54	449.28	0.00	0.00	551.25	3,065.29	84.76
I.M.R.F./Soc. Sec. Fund	50 E 2134 2130 00 300 000000	3,228.64	345.59	0.00	0.00	1,160.81	2,067.83	64.05
I.M.R.F./Soc. Sec. Fund	50 E 2134 2130 00 302 000000	3,011.78	271.76	0.00	0.00	1,129.77	1,882.01	291 62.49
I.M.R.F./Soc. Sec. Fund	50 E 2134 2140 00 300 000000	0.00	80.82	0.00	0.00	-484.15	484.15	0.00
I.M.R.F./Soc. Sec. Fund	50 E 2134 2140 00 302 000000	0.00	63.56	0.00	0.00	-442.91	442.91	0.00
I.M.R.F./Soc. Sec. Fund	50 E 2140 0000 00 000 000000	0.00	0.00	0.00	0.00	0.00	0.00	0.00
I.M.R.F./Soc. Sec. Fund	50 E 2140 1100 00 300 000000	0.00	0.00	0.00	0.00	0.00	0.00	0.00
I.M.R.F./Soc. Sec. Fund	50 E 2140 1100 00 300 000004	0.00	0.00	0.00	0.00	0.00	0.00	0.00
I.M.R.F./Soc. Sec. Fund	50 E 2140 2140 00 000 000000	1,969.20	172.16	0.00	0.00	350.66	1,618.54	82.19
I.M.R.F./Soc. Sec. Fund	50 E 2190 2120 00 300 000000	3,991.09	720.68	0.00	0.00	341.16	3,649.93	91.45
I.M.R.F./Soc. Sec. Fund	50 E 2190 2130 00 300 000000	3,762.55	302.94	0.00	0.00	1,768.78	1,993.77	52.99
I.M.R.F./Soc. Sec. Fund	50 E 2190 2140 00 300 000000	0.00	70.86	0.00	0.00	-630.05	630.05	0.00
I.M.R.F./Soc. Sec. Fund	50 E 2210 2120 00 300 000000	0.00	0.00	0.00	0.00	0.00	0.00	0.00
I.M.R.F./Soc. Sec. Fund	50 E 2210 2120 00 302 000000	5,912.77	286.66	0.00	0.00	3,375.34	2,537.43	42.91
I.M.R.F./Soc. Sec. Fund	50 E 2210 2130 00 300 000000	4,723.60	0.00	0.00	0.00	4,723.60	0.00	0.00
I.M.R.F./Soc. Sec. Fund	50 E 2210 2130 00 302 000000	0.00	141.44	0.00	0.00	-1,381.63	1,381.63	0.00
I.M.R.F./Soc. Sec. Fund	50 E 2210 2140 00 300 000000	1,517.19	103.18	0.00	0.00	464.34	1,052.85	69.39
I.M.R.F./Soc. Sec. Fund	50 E 2210 2140 00 302 000000	0.00	33.08	0.00	0.00	-324.71	324.71	0.00
I.M.R.F./Soc. Sec. Fund	50 E 2212 2140 00 300 000000	0.00	0.00	0.00	0.00	0.00	0.00	0.00
I.M.R.F./Soc. Sec. Fund	50 E 2213 2120 00 300 000000	0.00	0.00	0.00	0.00	0.00	0.00	0.00
I.M.R.F./Soc. Sec. Fund	50 E 2213 2130 00 300 000000	0.00	0.00	0.00	0.00	0.00	0.00	0.00
I.M.R.F./Soc. Sec. Fund	50 E 2213 2140 00 300 000000	0.00	0.00	0.00	0.00	0.00	0.00	0.00

Expenditure Report

Fiscal Year: 2020-2021
Month: March

COUNTY OF GRUNDY SCHOOL DIST 111

Fund Description	Account Number	Revised Budget	MTD Activity	Encumbrance	Pending Activity	Available Funds	Year to Date Activity	Percent of Budget Used
I.M.R.F./Soc. Sec. Fund	50 E 2222 2120 00 300 000000	4,525.89	429.46	0.00	0.00	823.51	3,702.38	81.80
I.M.R.F./Soc. Sec. Fund	50 E 2222 2120 00 302 000000	2,463.77	220.66	0.00	0.00	515.31	1,948.46	79.08
I.M.R.F./Soc. Sec. Fund	50 E 2222 2130 00 300 000000	3,632.08	259.78	0.00	0.00	1,359.26	2,272.82	62.58
I.M.R.F./Soc. Sec. Fund	50 E 2222 2130 00 302 000000	1,968.16	122.50	0.00	0.00	807.26	1,160.90	58.98
I.M.R.F./Soc. Sec. Fund	50 E 2222 2140 00 300 000000	850.82	60.75	0.00	0.00	317.25	533.57	62.71
I.M.R.F./Soc. Sec. Fund	50 E 2222 2140 00 300 000001	0.00	58.04	0.00	0.00	-509.02	509.02	0.00
I.M.R.F./Soc. Sec. Fund	50 E 2222 2140 00 302 000000	0.00	28.64	0.00	0.00	-272.74	272.74	0.00
I.M.R.F./Soc. Sec. Fund	50 E 2225 2120 00 300 000000	16,419.49	741.62	0.00	0.00	9,854.89	6,564.60	39.98
I.M.R.F./Soc. Sec. Fund	50 E 2225 2120 00 300 000001	0.00	581.04	0.00	0.00	-5,158.01	5,158.01	0.00
I.M.R.F./Soc. Sec. Fund	50 E 2225 2120 00 302 000000	0.00	188.22	0.00	0.00	-840.66	840.66	0.00
I.M.R.F./Soc. Sec. Fund	50 E 2225 2130 00 300 000000	13,034.44	430.16	0.00	0.00	8,472.46	4,561.98	35.00
I.M.R.F./Soc. Sec. Fund	50 E 2225 2130 00 300 000001	0.00	339.62	0.00	0.00	-3,081.62	3,081.62	0.00
I.M.R.F./Soc. Sec. Fund	50 E 2225 2130 00 302 000000	0.00	113.34	0.00	0.00	-504.61	504.61	0.00
I.M.R.F./Soc. Sec. Fund	50 E 2225 2140 00 300 000000	0.00	100.60	0.00	0.00	-1,074.32	1,074.32	0.00
I.M.R.F./Soc. Sec. Fund	50 E 2225 2140 00 300 000001	0.00	79.42	0.00	0.00	-723.96	723.96	0.00
I.M.R.F./Soc. Sec. Fund	50 E 2225 2140 00 302 000000	0.00	26.50	0.00	0.00	-117.99	117.99	0.00
I.M.R.F./Soc. Sec. Fund	50 E 2300 2120 00 000 000000	42.97	0.00	0.00	0.00	-11.82	54.79	127.51
I.M.R.F./Soc. Sec. Fund	50 E 2300 2130 00 000 000000	34.72	0.00	0.00	0.00	0.83	33.89	97.61
I.M.R.F./Soc. Sec. Fund	50 E 2300 2140 00 000 000000	25.38	0.00	0.00	0.00	-8.55	33.93	133.69
I.M.R.F./Soc. Sec. Fund	50 E 2310 2130 00 300 000000	0.00	0.00	0.00	0.00	0.00	0.00	0.00
I.M.R.F./Soc. Sec. Fund	50 E 2310 2140 00 300 000000	0.00	0.00	0.00	0.00	0.00	0.00	0.00
I.M.R.F./Soc. Sec. Fund	50 E 2312 2120 00 300 000000	238.15	0.00	0.00	0.00	238.15	0.00	0.00
I.M.R.F./Soc. Sec. Fund	50 E 2312 2130 00 300 000000	198.64	0.00	0.00	0.00	198.64	0.00	0.00
I.M.R.F./Soc. Sec. Fund	50 E 2313 2140 00 300 000000	0.00	0.00	0.00	0.00	0.00	0.00	0.00
I.M.R.F./Soc. Sec. Fund	50 E 2321 2120 00 300 000000	6,916.43	617.00	0.00	0.00	1,333.81	5,582.62	80.72
I.M.R.F./Soc. Sec. Fund	50 E 2321 2130 00 300 000000	5,484.51	370.28	0.00	0.00	2,081.53	3,402.98	62.05
I.M.R.F./Soc. Sec. Fund	50 E 2321 2140 00 300 000000	0.00	86.60	0.00	0.00	-799.44	799.44	0.00
I.M.R.F./Soc. Sec. Fund	50 E 2321 2140 00 300 000001	2,837.68	236.34	0.00	0.00	701.91	2,135.77	75.26
I.M.R.F./Soc. Sec. Fund	50 E 2367 2120 00 300 000000	23,161.09	1,762.73	0.00	0.00	7,537.68	15,623.41	67.46
I.M.R.F./Soc. Sec. Fund	50 E 2367 2120 00 300 000001	0.00	53.74	0.00	0.00	-338.91	338.91	0.00
I.M.R.F./Soc. Sec. Fund	50 E 2367 2120 00 300 000002	0.00	112.65	0.00	0.00	-976.23	976.23	0.00
I.M.R.F./Soc. Sec. Fund	50 E 2367 2130 00 300 000000	17,655.36	955.29	0.00	0.00	8,782.61	8,872.75	50.26
I.M.R.F./Soc. Sec. Fund	50 E 2367 2130 00 300 000001	0.00	32.50	0.00	0.00	-207.94	207.94	0.00

Expenditure Report

Fiscal Year: 2020-2021
Month: March

COUNTY OF GRUNDY SCHOOL DIST 111

Fund Description	Account Number	Revised Budget	MTD Activity	Encumbrance	Pending Activity	Available Funds	Year to Date Activity	Percent of Budget Used
I.M.R.F./Soc. Sec. Fund	50 E 2367 2130 00 300 000002	0.00	55.25	0.00	0.00	-503.54	503.54	0.00
I.M.R.F./Soc. Sec. Fund	50 E 2367 2140 00 300 000000	0.00	223.42	0.00	0.00	-2,084.28	2,084.28	0.00
I.M.R.F./Soc. Sec. Fund	50 E 2367 2140 00 300 000001	0.00	7.59	0.00	0.00	-48.73	48.73	0.00
I.M.R.F./Soc. Sec. Fund	50 E 2367 2140 00 300 000002	0.00	63.84	0.00	0.00	-576.72	576.72	0.00
I.M.R.F./Soc. Sec. Fund	50 E 2410 2120 00 300 000000	8,664.98	335.12	0.00	0.00	5,698.55	2,966.43	34.23
I.M.R.F./Soc. Sec. Fund	50 E 2410 2120 00 300 000002	0.00	445.62	0.00	0.00	-3,944.56	3,944.56	0.00
I.M.R.F./Soc. Sec. Fund	50 E 2410 2130 00 300 000000	7,715.48	193.46	0.00	0.00	5,953.61	1,761.87	22.84
I.M.R.F./Soc. Sec. Fund	50 E 2410 2130 00 300 000002	0.00	257.32	0.00	0.00	-2,313.15	2,313.15	0.00
I.M.R.F./Soc. Sec. Fund	50 E 2410 2140 00 300 000000	0.00	45.24	0.00	0.00	-413.96	413.96	0.00
I.M.R.F./Soc. Sec. Fund	50 E 2410 2140 00 300 000001	8,162.95	165.20	0.00	0.00	6,670.26	1,492.69	18.29
I.M.R.F./Soc. Sec. Fund	50 E 2410 2140 00 300 000002	0.00	60.18	0.00	0.00	-543.45	543.45	0.00
I.M.R.F./Soc. Sec. Fund	50 E 2410 2140 00 300 000003	0.00	121.14	0.00	0.00	-1,089.06	1,089.06	0.00
I.M.R.F./Soc. Sec. Fund	50 E 2410 2140 00 300 000004	643.54	356.65	0.00	0.00	-2,591.86	3,235.40	502.75
I.M.R.F./Soc. Sec. Fund	50 E 2410 2140 00 302 000000	1,463.00	120.88	0.00	0.00	377.62	1,085.38	29374.19
I.M.R.F./Soc. Sec. Fund	50 E 2490 2120 00 300 000000	6,608.97	527.71	0.00	0.00	2,170.21	4,438.76	67.16
I.M.R.F./Soc. Sec. Fund	50 E 2490 2130 00 300 000000	4,570.78	266.83	0.00	0.00	2,283.42	2,287.36	50.04
I.M.R.F./Soc. Sec. Fund	50 E 2490 2140 00 300 000000	0.00	62.40	0.00	0.00	-538.02	538.02	0.00
I.M.R.F./Soc. Sec. Fund	50 E 2510 2120 00 300 000000	7,983.24	1,441.56	0.00	0.00	682.26	7,300.98	91.45
I.M.R.F./Soc. Sec. Fund	50 E 2510 2130 00 300 000000	7,526.04	605.94	0.00	0.00	3,538.05	3,987.99	52.99
I.M.R.F./Soc. Sec. Fund	50 E 2510 2140 00 300 000000	0.00	141.70	0.00	0.00	-1,260.06	1,260.06	0.00
I.M.R.F./Soc. Sec. Fund	50 E 2525 2120 00 300 000000	14,679.48	851.60	0.00	0.00	7,141.07	7,538.41	51.35
I.M.R.F./Soc. Sec. Fund	50 E 2525 2130 00 300 000000	11,671.35	485.62	0.00	0.00	7,274.57	4,396.78	37.67
I.M.R.F./Soc. Sec. Fund	50 E 2525 2140 00 300 000000	0.00	113.56	0.00	0.00	-1,032.99	1,032.99	0.00
I.M.R.F./Soc. Sec. Fund	50 E 2540 2120 00 300 000000	0.00	157.80	0.00	0.00	-663.01	663.01	0.00
I.M.R.F./Soc. Sec. Fund	50 E 2540 2120 00 300 000001	63,290.71	4,949.27	0.00	0.00	21,999.47	41,291.24	65.24
I.M.R.F./Soc. Sec. Fund	50 E 2540 2120 00 302 000000	0.00	0.00	0.00	0.00	0.00	0.00	0.00
I.M.R.F./Soc. Sec. Fund	50 E 2540 2130 00 300 000000	0.00	95.43	0.00	0.00	-404.29	404.29	0.00
I.M.R.F./Soc. Sec. Fund	50 E 2540 2130 00 300 000001	52,409.12	3,283.56	0.00	0.00	24,874.74	27,534.38	52.54
I.M.R.F./Soc. Sec. Fund	50 E 2540 2130 00 302 000000	0.00	0.00	0.00	0.00	-462.88	462.88	0.00
I.M.R.F./Soc. Sec. Fund	50 E 2540 2140 00 300 000000	0.00	22.31	0.00	0.00	-94.55	94.55	0.00
I.M.R.F./Soc. Sec. Fund	50 E 2540 2140 00 300 000001	0.00	767.96	0.00	0.00	-6,465.87	6,465.87	0.00
I.M.R.F./Soc. Sec. Fund	50 E 2540 2140 00 302 000000	0.00	0.00	0.00	0.00	-108.23	108.23	0.00
I.M.R.F./Soc. Sec. Fund	50 E 2541 2120 00 300 000000	0.00	0.00	0.00	0.00	0.00	0.00	0.00

Expenditure Report

Fiscal Year: 2020-2021
Month: March

COUNTY OF GRUNDY SCHOOL DIST 111

Fund Description	Account Number	Revised Budget	MTD Activity	Encumbrance	Pending Activity	Available Funds	Year to Date Activity	Percent of Budget Used
I.M.R.F./Soc. Sec. Fund	50 E 2541 2130 00 300 000000	2,438.12	0.00	0.00	0.00	1,493.15	944.97	38.76
I.M.R.F./Soc. Sec. Fund	50 E 2541 2140 00 300 000000	0.00	0.00	0.00	0.00	-226.34	226.34	0.00
I.M.R.F./Soc. Sec. Fund	50 E 2550 2120 00 300 000000	121,841.02	659.62	0.00	0.00	117,994.92	3,846.10	3.16
I.M.R.F./Soc. Sec. Fund	50 E 2550 2120 00 300 000001	0.00	62.85	0.00	0.00	-441.92	441.92	0.00
I.M.R.F./Soc. Sec. Fund	50 E 2550 2120 00 300 000002	0.00	3,470.35	0.00	0.00	-28,193.49	28,193.49	0.00
I.M.R.F./Soc. Sec. Fund	50 E 2550 2120 00 300 000003	0.00	3,701.21	0.00	0.00	-32,707.01	32,707.01	0.00
I.M.R.F./Soc. Sec. Fund	50 E 2550 2120 00 300 000004	0.00	53.82	0.00	0.00	-476.33	476.33	0.00
I.M.R.F./Soc. Sec. Fund	50 E 2550 2120 00 300 000005	0.00	623.05	0.00	0.00	-5,643.50	5,643.50	0.00
I.M.R.F./Soc. Sec. Fund	50 E 2550 2120 00 300 000009	0.00	424.34	0.00	0.00	-3,624.90	3,624.90	0.00
I.M.R.F./Soc. Sec. Fund	50 E 2550 2130 00 300 000000	98,689.91	394.07	0.00	0.00	96,337.95	2,351.96	2.38
I.M.R.F./Soc. Sec. Fund	50 E 2550 2130 00 300 000001	0.00	38.02	0.00	0.00	-270.89	270.89	0.00
I.M.R.F./Soc. Sec. Fund	50 E 2550 2130 00 300 000002	0.00	2,105.67	0.00	0.00	-17,313.27	17,313.27	0.00
I.M.R.F./Soc. Sec. Fund	50 E 2550 2130 00 300 000003	0.00	2,169.67	0.00	0.00	-20,023.20	20,023.20	0.00
I.M.R.F./Soc. Sec. Fund	50 E 2550 2130 00 300 000004	0.00	31.30	0.00	0.00	-284.95	284.95	0.00
I.M.R.F./Soc. Sec. Fund	50 E 2550 2130 00 300 000005	0.00	408.87	0.00	0.00	-3,501.73	3,501.73	0.00
I.M.R.F./Soc. Sec. Fund	50 E 2550 2130 00 300 000009	0.00	250.74	0.00	0.00	-2,204.17	2,204.17	0.00
I.M.R.F./Soc. Sec. Fund	50 E 2550 2140 00 300 000000	0.00	92.16	0.00	0.00	-551.78	551.78	0.00
I.M.R.F./Soc. Sec. Fund	50 E 2550 2140 00 300 000001	0.00	8.89	0.00	0.00	-63.35	63.35	0.00
I.M.R.F./Soc. Sec. Fund	50 E 2550 2140 00 300 000002	0.00	492.42	0.00	0.00	-4,065.02	4,065.02	0.00
I.M.R.F./Soc. Sec. Fund	50 E 2550 2140 00 300 000003	0.00	507.29	0.00	0.00	-4,703.61	4,703.61	0.00
I.M.R.F./Soc. Sec. Fund	50 E 2550 2140 00 300 000004	0.00	7.32	0.00	0.00	-66.92	66.92	0.00
I.M.R.F./Soc. Sec. Fund	50 E 2550 2140 00 300 000005	0.00	95.63	0.00	0.00	-824.10	824.10	0.00
I.M.R.F./Soc. Sec. Fund	50 E 2550 2140 00 300 000009	0.00	58.64	0.00	0.00	-518.17	518.17	0.00
I.M.R.F./Soc. Sec. Fund	50 E 2554 2120 00 300 000000	17,209.59	799.24	0.00	520.99	12,144.95	4,543.65	26.40
I.M.R.F./Soc. Sec. Fund	50 E 2554 2120 00 300 000001	0.00	610.24	0.00	0.00	-5,401.71	5,401.71	0.00
I.M.R.F./Soc. Sec. Fund	50 E 2554 2130 00 300 000000	13,105.35	446.80	0.00	456.88	10,468.72	2,179.75	16.63
I.M.R.F./Soc. Sec. Fund	50 E 2554 2130 00 300 000001	0.00	362.96	0.00	0.00	-3,262.46	3,262.46	0.00
I.M.R.F./Soc. Sec. Fund	50 E 2554 2140 00 300 000000	0.00	104.48	0.00	0.00	-943.68	943.68	0.00
I.M.R.F./Soc. Sec. Fund	50 E 2554 2140 00 300 000001	0.00	84.88	0.00	0.00	-766.52	766.52	0.00
I.M.R.F./Soc. Sec. Fund	50 E 2632 2120 00 300 000000	2,658.74	216.86	0.00	0.00	913.51	1,745.23	65.64
I.M.R.F./Soc. Sec. Fund	50 E 2632 2130 00 300 000000	1,630.31	114.40	0.00	0.00	732.14	898.17	55.09
I.M.R.F./Soc. Sec. Fund	50 E 2632 2140 00 300 000000	0.00	26.76	0.00	0.00	-211.19	211.19	0.00
I.M.R.F./Soc. Sec. Fund	50 E 2633 2120 00 300 000000	6,666.94	594.74	0.00	0.00	1,402.36	5,264.58	78.97

294

Expenditure Report

Fiscal Year: 2020-2021
Month: March

COUNTY OF GRUNDY SCHOOL DIST 111

Fund Description	Account Number	Revised Budget	MTD Activity	Encumbrance	Pending Activity	Available Funds	Year to Date Activity	Percent of Budget Used
I.M.R.F./Soc. Sec. Fund	50 E 2633 2130 00 300 000000	5,326.46	359.74	0.00	0.00	2,094.13	3,232.33	60.68
I.M.R.F./Soc. Sec. Fund	50 E 2633 2140 00 300 000000	0.00	84.14	0.00	0.00	-759.48	759.48	0.00
I.M.R.F./Soc. Sec. Fund	50 E 3200 2120 00 300 000000	0.00	0.00	0.00	0.00	0.00	0.00	0.00
I.M.R.F./Soc. Sec. Fund	50 E 3200 2130 00 300 000000	0.00	0.00	0.00	0.00	0.00	0.00	0.00
I.M.R.F./Soc. Sec. Fund	50 E 3200 2130 00 300 000001	0.00	0.00	0.00	0.00	0.00	0.00	0.00
I.M.R.F./Soc. Sec. Fund	50 E 3200 2140 00 300 000000	0.00	0.00	0.00	0.00	0.00	0.00	0.00
I.M.R.F./Soc. Sec. Fund	50 E 4100 2120 00 300 000000	0.00	0.00	0.00	0.00	0.00	0.00	0.00
I.M.R.F./Soc. Sec. Fund	50 E 4100 2130 00 300 000000	0.00	0.00	0.00	0.00	0.00	0.00	0.00
I.M.R.F./Soc. Sec. Fund	50 E 4120 2140 00 300 000000	0.00	0.00	0.00	0.00	0.00	0.00	0.00
I.M.R.F./Soc. Sec. Fund	50 E 4810 2120 00 454 000000	0.00	0.00	0.00	0.00	0.00	0.00	0.00
I.M.R.F./Soc. Sec. Fund	50 E 4810 2120 00 454 000001	0.00	0.00	0.00	0.00	0.00	0.00	0.00
I.M.R.F./Soc. Sec. Fund	50 E 4810 2130 00 454 000000	0.00	0.00	0.00	0.00	0.00	0.00	0.00
I.M.R.F./Soc. Sec. Fund	50 E 4810 2130 00 454 000001	0.00	0.00	0.00	0.00	0.00	0.00	0.00
50 - - - - -		916,158.58	74,999.99	0.00	977.87	292,330.78	622,849.93	295
5- - - - -		916,158.58	74,999.99	0.00	977.87	292,330.78	622,849.93	
Capital Projects Fund or	60 E 2530 5000 00 300 000000	0.00	0.00	0.00	0.00	0.00	0.00	0.00
Capital Projects Fund or	60 E 2530 5000 00 300 000001	0.00	0.00	0.00	0.00	0.00	0.00	0.00
Capital Projects Fund or	60 E 2532 3900 00 300 000000	0.00	0.00	0.00	0.00	0.00	0.00	0.00
Capital Projects Fund or	60 E 2532 5200 00 000 000000	0.00	0.00	0.00	0.00	0.00	0.00	0.00
Capital Projects Fund or	60 E 2532 5300 00 000 000000	0.00	0.00	0.00	0.00	0.00	0.00	0.00
Capital Projects Fund or	60 E 2533 3000 00 000 000000	0.00	0.00	0.00	0.00	0.00	0.00	0.00
Capital Projects Fund or	60 E 2533 3000 00 300 000000	0.00	0.00	0.00	0.00	0.00	0.00	0.00
Capital Projects Fund or	60 E 2533 3100 00 300 000000	0.00	0.00	0.00	0.00	0.00	0.00	0.00
Capital Projects Fund or	60 E 2533 3100 00 300 000001	0.00	0.00	0.00	0.00	0.00	0.00	0.00
Capital Projects Fund or	60 E 2533 3100 00 300 000002	0.00	0.00	0.00	0.00	0.00	0.00	0.00
Capital Projects Fund or	60 E 2533 3100 00 300 000003	0.00	0.00	0.00	0.00	0.00	0.00	0.00
Capital Projects Fund or	60 E 2533 3100 00 300 000004	0.00	0.00	0.00	0.00	0.00	0.00	0.00
Capital Projects Fund or	60 E 2533 3100 00 300 000005	0.00	0.00	0.00	0.00	0.00	0.00	0.00
Capital Projects Fund or	60 E 2533 3180 00 300 000000	0.00	0.00	0.00	0.00	0.00	0.00	0.00
Capital Projects Fund or	60 E 2533 3190 00 300 000000	0.00	0.00	0.00	0.00	0.00	0.00	0.00
Capital Projects Fund or	60 E 2533 3900 00 300 000000	0.00	0.00	0.00	0.00	0.00	0.00	0.00

Expenditure Report

Fiscal Year: 2020-2021
Month: March

COUNTY OF GRUNDY SCHOOL DIST 111

Fund Description	Account Number	Revised Budget	MTD Activity	Encumbrance	Pending Activity	Available Funds	Year to Date Activity	Percent of Budget Used
Capital Projects Fund or	60 E 2533 3900 00 300 000001	0.00	0.00	0.00	0.00	0.00	0.00	0.00
Capital Projects Fund or	60 E 2535 3000 00 300 000000	0.00	0.00	0.00	0.00	0.00	0.00	0.00
Capital Projects Fund or	60 E 2535 3230 00 000 000000	3,000,000.00	0.00	0.00	0.00	1,824,990.10	1,175,009.90	39.17
Capital Projects Fund or	60 E 2535 3230 00 300 000000	0.00	0.00	0.00	0.00	0.00	0.00	0.00
Capital Projects Fund or	60 E 2535 3230 00 300 000001	0.00	0.00	0.00	0.00	0.00	0.00	0.00
Capital Projects Fund or	60 E 2535 5000 00 300 000000	0.00	0.00	0.00	0.00	0.00	0.00	0.00
Capital Projects Fund or	60 E 2535 5000 00 300 000001	0.00	0.00	0.00	0.00	0.00	0.00	0.00
Capital Projects Fund or	60 E 2535 5000 00 300 000002	0.00	0.00	0.00	0.00	0.00	0.00	0.00
Capital Projects Fund or	60 E 2535 5000 00 300 000003	0.00	0.00	0.00	0.00	0.00	0.00	0.00
Capital Projects Fund or	60 E 2535 5310 00 000 000000	0.00	0.00	0.00	0.00	0.00	0.00	0.00
Capital Projects Fund or	60 E 2535 5400 00 000 000000	0.00	0.00	0.00	0.00	0.00	0.00	0.00
Capital Projects Fund or	60 E 2535 5400 00 000 000001	0.00	0.00	0.00	0.00	0.00	0.00	0.00
Capital Projects Fund or	60 E 2535 5500 00 300 000000	0.00	0.00	0.00	0.00	0.00	0.00	0.00
Capital Projects Fund or	60 E 2535 5500 00 300 000001	0.00	0.00	0.00	0.00	0.00	0.00	0.00
Capital Projects Fund or	60 E 2535 5500 00 300 000002	0.00	0.00	0.00	0.00	0.00	0.00	0.00
Capital Projects Fund or	60 E 2535 5500 00 300 000003	0.00	0.00	0.00	0.00	0.00	0.00	0.00
Capital Projects Fund or	60 E 2535 5500 00 300 000004	0.00	0.00	0.00	0.00	0.00	0.00	0.00
Capital Projects Fund or	60 E 2535 5500 00 300 000005	0.00	0.00	0.00	0.00	0.00	0.00	0.00
Capital Projects Fund or	60 E 8140 6610 00 300 000000	0.00	0.00	0.00	0.00	0.00	0.00	0.00
Capital Projects Fund or	60 E 8180 6110 00 300 000000	0.00	0.00	0.00	0.00	0.00	0.00	0.00
60 - - - - -		3,000,000.00	0.00	0.00	0.00	1,824,990.10	1,175,009.90	0.00
6- - - - -		3,000,000.00	0.00	0.00	0.00	1,824,990.10	1,175,009.90	0.00
Working Cash Fund	70 E 8180 6110 00 300 000000	0.00	0.00	0.00	0.00	0.00	0.00	0.00
Working Cash Fund	70 E 8180 6610 00 300 000000	0.00	0.00	0.00	0.00	0.00	0.00	0.00
Working Cash Fund	70 E 8990 6610 00 300 000000	0.00	0.00	0.00	0.00	0.00	0.00	0.00
70 - - - - -		0.00	0.00	0.00	0.00	0.00	0.00	0.00
7- - - - -		0.00	0.00	0.00	0.00	0.00	0.00	0.00
Tort Immunity and Judgment	80 E 1130 2220 00 000 000000	0.00	57,497.46	0.00	24,984.14	-206,523.58	181,539.44	0.00
Tort Immunity and Judgment	80 E 1130 2230 00 000 000000	0.00	91.45	0.00	191.49	-1,531.99	1,340.50	0.00

Expenditure Report

Fiscal Year: 2020-2021
Month: March

COUNTY OF GRUNDY SCHOOL DIST 111

Fund Description	Account Number	Revised Budget	MTD Activity	Encumbrance	Pending Activity	Available Funds	Year to Date Activity	Percent of Budget Used
Tort Immunity and Judgment	80 E 2110 0000 00 000 000000	0.00	0.00	0.00	0.00	0.00	0.00	0.00
Tort Immunity and Judgment	80 E 2220 0000 00 000 000000	0.00	0.00	0.00	0.00	0.00	0.00	0.00
Tort Immunity and Judgment	80 E 2310 2000 00 300 000000	0.00	0.00	0.00	0.00	0.00	0.00	0.00
Tort Immunity and Judgment	80 E 2310 3180 00 300 000000	50,000.00	2,575.00	0.00	2,845.75	-5,941.50	53,095.75	106.19
Tort Immunity and Judgment	80 E 2362 3800 00 300 000000	180,000.00	27,386.00	0.00	13,693.00	45,891.00	120,416.00	66.90
Tort Immunity and Judgment	80 E 2363 3800 00 300 000000	0.00	0.00	0.00	0.00	0.00	0.00	0.00
Tort Immunity and Judgment	80 E 2364 3800 00 300 000000	0.00	0.00	0.00	0.00	0.00	0.00	0.00
Tort Immunity and Judgment	80 E 2364 3800 00 300 000001	185,000.00	0.00	0.00	0.00	-10,522.00	195,522.00	105.69
Tort Immunity and Judgment	80 E 2364 3800 00 300 000002	0.00	0.00	0.00	0.00	0.00	0.00	0.00
Tort Immunity and Judgment	80 E 2364 3800 00 300 000003	15,000.00	0.00	0.00	0.00	-718.00	15,718.00	104.79
Tort Immunity and Judgment	80 E 2364 3800 00 300 000004	2,500.00	0.00	0.00	0.00	330.00	2,170.00	86.80
Tort Immunity and Judgment	80 E 2365 3900 00 000 000000	16,500.00	0.00	0.00	0.00	165.00	16,335.00	99.00
Tort Immunity and Judgment	80 E 2365 3900 00 300 000000	15,000.00	0.00	0.00	0.00	15,000.00	0.00	0.00
Tort Immunity and Judgment	80 E 2365 3900 00 300 000001	95,000.00	13,410.91	0.00	12,671.30	17,482.27	64,846.43	297.68.26
Tort Immunity and Judgment	80 E 2365 3900 00 300 000002	50,000.00	1,251.67	0.00	5,627.38	19,492.46	24,880.16	49.76
Tort Immunity and Judgment	80 E 2365 3900 00 300 000003	45,000.00	0.00	0.00	0.00	45,000.00	0.00	0.00
Tort Immunity and Judgment	80 E 2365 3900 00 302 000000	75,000.00	648.77	0.00	10,309.30	40,255.05	24,435.65	32.58
Tort Immunity and Judgment	80 E 2367 1000 00 300 000000	245,000.00	17,197.54	0.00	0.00	91,277.66	153,722.34	62.74
Tort Immunity and Judgment	80 E 2367 1000 00 300 000001	3,800.00	524.08	0.00	0.00	615.35	3,184.65	83.81
Tort Immunity and Judgment	80 E 2367 1000 00 300 000002	59,206.25	4,806.55	0.00	0.00	15,640.49	43,565.76	73.58
Tort Immunity and Judgment	80 E 2367 1200 00 300 000000	5,000.00	0.00	0.00	0.00	5,000.00	0.00	0.00
Tort Immunity and Judgment	80 E 2367 1300 00 300 000000	0.00	0.00	0.00	0.00	0.00	0.00	0.00
Tort Immunity and Judgment	80 E 2367 2110 00 300 000000	0.00	0.00	0.00	0.00	-24.04	24.04	0.00
Tort Immunity and Judgment	80 E 2367 2110 00 300 000002	5,700.00	468.14	0.00	0.00	1,971.08	3,728.92	65.42
Tort Immunity and Judgment	80 E 2367 2220 00 300 000000	77,000.00	7,339.58	0.00	0.00	18,701.21	58,298.79	75.71
Tort Immunity and Judgment	80 E 2367 2220 00 300 000001	0.00	0.40	0.00	0.00	-1.20	1.20	0.00
Tort Immunity and Judgment	80 E 2367 2220 00 300 000002	0.00	1,725.72	0.00	0.00	-12,696.39	12,696.39	0.00
Tort Immunity and Judgment	80 E 2367 2230 00 300 000002	0.00	33.36	0.00	0.00	-119.82	119.82	0.00
Tort Immunity and Judgment	80 E 2542 3000 00 000 000000	25,000.00	0.00	0.00	0.00	25,000.00	0.00	0.00
Tort Immunity and Judgment	80 E 2542 3200 00 000 000000	5,000.00	0.00	0.00	0.00	5,000.00	0.00	0.00
Tort Immunity and Judgment	80 E 2546 4100 00 300 000000	15,000.00	0.00	0.00	0.00	15,000.00	0.00	0.00
Tort Immunity and Judgment	80 E 2546 4100 00 302 000000	15,000.00	0.00	0.00	0.00	15,000.00	0.00	0.00
Tort Immunity and Judgment	80 E 2546 5400 00 300 000000	20,000.00	0.00	0.00	1,995.49	18,004.51	0.00	0.00

Expenditure Report

Fiscal Year: 2020-2021
Month: March

COUNTY OF GRUNDY SCHOOL DIST 111

Fund Description	Account Number	Revised Budget	MTD Activity	Encumbrance	Pending Activity	Available Funds	Year to Date Activity	Percent of Budget Used
Tort Immunity and Judgment	80 E 2546 5400 00 302 000000	20,000.00	0.00	0.00	0.00	20,000.00	0.00	0.00
80 -	-----	1,224,706.25	134,956.63	0.00	72,317.85	176,747.56	975,640.84	
8-	-----	1,224,706.25	134,956.63	0.00	72,317.85	176,747.56	975,640.84	
Fire Prevention & Safety	90 E 2542 3000 00 300 000000	0.00	0.00	0.00	0.00	0.00	0.00	0.00
Fire Prevention & Safety	90 E 2542 3000 00 300 000001	0.00	0.00	0.00	0.00	0.00	0.00	0.00
Fire Prevention & Safety	90 E 2542 3000 00 300 000002	0.00	0.00	0.00	0.00	0.00	0.00	0.00
Fire Prevention & Safety	90 E 2542 5300 00 300 000000	8,000,000.00	0.00	0.00	0.00	1,807,059.95	6,192,940.05	77.41
Fire Prevention & Safety	90 E 2542 5310 00 300 000000	0.00	0.00	0.00	0.00	0.00	0.00	0.00
90 -	-----	8,000,000.00	0.00	0.00	0.00	1,807,059.95	6,192,940.05	
9-	-----	8,000,000.00	0.00	0.00	0.00	1,807,059.95	6,192,940.05	
Account Monthly Activity Grand Totals:		59,149,395.45	6,592,646.74	124,163.06	727,997.32	14,239,383.12	44,056,382.20	298

Revenue Report

Fiscal Year: 2020-2021
Month: March

COUNTY OF GRUNDY SCHOOL DIST 111

Account Number	Account Description	Revised Budget	Monthly Activity	Encumbrance	Pending Activity	Available Funds	Year to Date Activity	Percent of Budget Used
10 R 1110 0000 00 000 000000	PRIOR YEAR TAXES	0.00	0.00	0.00	0.00	0.00	0.00	0.00
10 R 1111 0000 00 000 000000	GRUNDY CO TAXES	6,551,544.00	0.00	0.00	0.00	-1,001,399.54	7,552,943.54	115.28
10 R 1112 0000 00 000 000000	KENDALL CO TAXES	1,026,573.36	0.00	0.00	0.00	-5,798.73	1,032,372.09	100.56
10 R 1113 0000 00 000 000000	WILL CO TAXES	4,767,775.28	0.00	0.00	0.00	31,985.04	4,735,790.24	99.33
10 R 1114 0000 00 000 000000	GRUNDY CO EDPA SURPLUS	299,159.00	0.00	0.00	0.00	299,159.00	0.00	0.00
10 R 1122 0000 00 000 000000	KENDALL CO - EARLY	1,104,614.12	0.00	0.00	0.00	1,104,614.12	0.00	0.00
10 R 1123 0000 00 000 000000	WILL CO - EARLY DISTR	5,337,374.13	0.00	0.00	0.00	5,337,374.13	0.00	0.00
10 R 1210 0000 00 000 000000	MOBILE HOME TAX	4,800.00	0.00	0.00	0.00	4,800.00	0.00	0.00
10 R 1211 0000 00 000 000000	MOBILE HOME TAX SPECIAL	80.00	0.00	0.00	0.00	80.00	0.00	0.00
10 R 1211 0000 00 000 000001	GRUNDY CO TORT	0.00	0.00	0.00	0.00	0.00	0.00	0.00
10 R 1212 0000 00 000 000000	MOBILE HOME TAX - LEASE	200.00	0.00	0.00	0.00	200.00	0.00	0.00
10 R 1212 0000 00 000 000001	KENDALL CO TORT	0.00	0.00	0.00	0.00	0.00	0.00	299 0.00
10 R 1213 0000 00 000 000000	WILL CO TORT	0.00	0.00	0.00	0.00	0.00	0.00	0.00
10 R 1222 0000 00 000 000000	KENDALL CO TORT-EARLY	0.00	0.00	0.00	0.00	0.00	0.00	0.00
10 R 1223 0000 00 000 000000	WILL CO TORT-EARLY	0.00	0.00	0.00	0.00	0.00	0.00	0.00
10 R 1230 0000 00 000 000000	CPprt	538,560.00	19,273.15	0.00	0.00	329,927.99	208,632.01	38.74
10 R 1290 0000 00 000 000000	PAYMENTS IN LIEU OF	2,200.00	0.00	0.00	0.00	2,200.00	0.00	0.00
10 R 1291 0000 00 000 000000	LAG FEES	0.00	0.00	0.00	0.00	0.00	0.00	0.00
10 R 1292 0000 00 000 000000	PAYMENT IN LIEU OF	35.00	0.00	0.00	0.00	35.00	0.00	0.00
10 R 1293 0000 00 000 000000	PAYMENT IN LIEU OF	89.00	0.00	0.00	0.00	89.00	0.00	0.00
10 R 1311 0000 00 000 000000	NON-RESIDENT TUITION	0.00	0.00	0.00	0.00	0.00	0.00	0.00
10 R 1311 0000 00 000 000001	GRUNDY CO LEASE	178,678.00	0.00	0.00	0.00	-25,000.08	203,678.08	113.99
10 R 1312 0000 00 000 000000	KENDALL CO LEASE	28,931.53	0.00	0.00	0.00	145.27	28,786.26	99.50
10 R 1313 0000 00 000 000000	WILL CO LEASE	133,236.78	0.00	0.00	0.00	1,902.92	131,333.86	98.57
10 R 1314 0000 00 000 000000	GRUNDY CO LEASE EDPA	0.00	0.00	0.00	0.00	0.00	0.00	0.00
10 R 1321 0000 00 000 000000	TOTAL SUMMER SCHOOL	6,000.00	0.00	0.00	0.00	6,000.00	0.00	0.00
10 R 1322 0000 00 000 000000	KENDALL CO LEASE-EARLY	30,784.33	0.00	0.00	0.00	30,784.33	0.00	0.00
10 R 1323 0000 00 000 000000	WILL CO LEASE-EARLY	148,071.44	0.00	0.00	0.00	148,071.44	0.00	0.00

Revenue Report

Fiscal Year: 2020-2021
Month: March

COUNTY OF GRUNDY SCHOOL DIST 111

Account Number	Account Description	Revised Budget	Monthly Activity	Encumbrance	Pending Activity	Available Funds	Year to Date Activity	Percent of Budget Used
10 R 1411 0000 00 000 000000	GRUNDY CO SPEC ED	108,487.00	0.00	0.00	0.00	-15,331.74	123,818.74	114.13
10 R 1411 0000 00 000 000001	GRUNDY CO SPEC ED TIF	0.00	0.00	0.00	0.00	0.00	0.00	0.00
10 R 1412 0000 00 000 000000	KENDALL CO SPEC ED	16,998.78	0.00	0.00	0.00	74.64	16,924.14	99.56
10 R 1413 0000 00 000 000000	WILL CO SPEC ED	78,875.18	0.00	0.00	0.00	1,162.83	77,712.35	98.53
10 R 1414 0000 00 000 000000	GRUNDY CO SPEC ED EDPA	0.00	0.00	0.00	0.00	0.00	0.00	0.00
10 R 1422 0000 00 000 000000	KENDALL CO SPEC ED-	18,108.43	0.00	0.00	0.00	18,108.43	0.00	0.00
10 R 1423 0000 00 000 000000	WILL CO SPEC ED-EARLY	87,576.89	0.00	0.00	0.00	87,576.89	0.00	0.00
10 R 1510 0000 00 000 000000	CHECKING INTEREST	0.00	0.00	0.00	0.00	0.00	0.00	0.00
10 R 1511 0000 00 000 000000	INVESTMENT INTEREST	200,000.00	1,425.19	0.00	0.00	182,162.74	17,837.26	8.92
10 R 1611 0000 00 000 000000	CAFETERIA SALES CASH	100,000.00	1,464.25	0.00	0.00	86,602.97	13,397.03	13.40
10 R 1612 0000 00 000 000000	CAFETERIA SALES CREDIT	100,000.00	636.98	0.00	-142.95	93,771.86	6,371.09	6.37
10 R 1620 0000 00 000 000000	COFFEE SALES	0.00	0.00	0.00	0.00	0.00	0.00	300 0.00
10 R 1709 0000 00 000 000000	POST SEASON GATE	1,000.00	0.00	0.00	0.00	1,000.00	0.00	0.00
10 R 1710 0000 00 000 000000	ATHLETIC ENTRY FEES	1,000.00	0.00	0.00	0.00	1,000.00	0.00	0.00
10 R 1711 0000 00 000 000000	SOCCER ADMISSIONS	0.00	0.00	0.00	0.00	0.00	0.00	0.00
10 R 1712 0000 00 000 000000	FOOTBALL ADMISSIONS	1,000.00	0.00	0.00	0.00	1,000.00	0.00	0.00
10 R 1713 0000 00 000 000000	XC ADMISSIONS	0.00	0.00	0.00	0.00	0.00	0.00	0.00
10 R 1714 0000 00 000 000000	WRESTLING ADMISSIONS	0.00	0.00	0.00	0.00	0.00	0.00	0.00
10 R 1715 0000 00 000 000000	BOYS BSKTBLL ADMISSIONS	0.00	0.00	0.00	0.00	0.00	0.00	0.00
10 R 1716 0000 00 000 000000	GIRLS BSKTBLL	0.00	0.00	0.00	0.00	0.00	0.00	0.00
10 R 1717 0000 00 000 000000	VOLLEYBALL ADMISSIONS	0.00	0.00	0.00	0.00	0.00	0.00	0.00
10 R 1718 0000 00 000 000000	SPORT PASSES	0.00	0.00	0.00	0.00	0.00	0.00	0.00
10 R 1719 0000 00 000 000000	TRACK ADMISSIONS	0.00	0.00	0.00	0.00	0.00	0.00	0.00
10 R 1720 0000 00 000 000000	DRIVER EDUC FEES	0.00	0.00	0.00	0.00	-175.00	175.00	0.00
10 R 1721 0000 00 000 000000	LOCK FEES	3,500.00	0.00	0.00	0.00	3,500.00	0.00	0.00
10 R 1722 0000 00 000 000000	MISCELLANEOUS FEES	125,000.00	16,275.63	0.00	0.00	11,402.46	113,597.54	90.88
10 R 1723 0000 00 000 000000	P.E. UNIFORMS	100.00	0.00	0.00	0.00	100.00	0.00	0.00
10 R 1724 0000 00 000 000000	STUDENT PARKING FEES	50,000.00	2,040.00	0.00	0.00	39,860.00	10,140.00	20.28

Revenue Report

Fiscal Year: 2020-2021
Month: March

COUNTY OF GRUNDY SCHOOL DIST 111

Account Number	Account Description	Revised Budget	Monthly Activity	Encumbrance	Pending Activity	Available Funds	Year to Date Activity	Percent of Budget Used
10 R 1725 0000 00 000 000000	BOWLING ADMISSIONS	0.00	0.00	0.00	0.00	0.00	0.00	0.00
10 R 1726 0000 00 000 000000	SPRING MUSICAL	500.00	0.00	0.00	0.00	500.00	0.00	0.00
10 R 1727 0000 00 000 000000	FALL PLAY ADMISSIONS	0.00	0.00	0.00	0.00	-226.96	226.96	0.00
10 R 1728 0000 00 000 000000	STUDENT PURCHASES	0.00	0.00	0.00	0.00	0.00	0.00	0.00
10 R 1729 0000 00 000 000000	INVITE ADMISSIONS	100.00	0.00	0.00	0.00	100.00	0.00	0.00
10 R 1730 0000 00 000 000000	MADRIGALS ADMISSIONS	500.00	0.00	0.00	0.00	500.00	0.00	0.00
10 R 1731 0000 00 000 000000	ACTIVITY MISC	0.00	0.00	0.00	0.00	0.00	0.00	0.00
10 R 1732 0000 00 000 000000	SPORT PASSES	500.00	0.00	0.00	0.00	500.00	0.00	0.00
10 R 1733 0000 00 000 000000	LACROSSE ADMISSIONS	0.00	0.00	0.00	0.00	0.00	0.00	0.00
10 R 1790 0000 00 000 000000	OTHER PUPIL ACT REVENUE	0.00	0.00	0.00	0.00	0.00	0.00	0.00
10 R 1811 0000 00 000 000000	TEXTBOOK FEES	662,000.00	22,596.25	0.00	0.00	100,637.71	561,362.29	84.80
10 R 1825 0000 00 000 000000	AP TESTING FEE	0.00	0.00	0.00	0.00	0.00	0.00	301.00
10 R 1826 0000 00 000 000000	SAT TESTING FEES	6,000.00	0.00	0.00	0.00	1,104.00	4,896.00	81.60
10 R 1827 0000 00 000 000000	SALE OF EQUIPMENT	500.00	0.00	0.00	0.00	500.00	0.00	0.00
10 R 1828 0000 00 000 000000	A/P TEST FEES	55,000.00	752.00	0.00	0.00	-7,856.60	62,856.60	114.28
10 R 1829 0000 00 000 000000	MATH RESALE REVENUE	0.00	0.00	0.00	0.00	0.00	0.00	0.00
10 R 1920 0000 00 000 000000	IMTT GRANT	0.00	0.00	0.00	0.00	0.00	0.00	0.00
10 R 1950 0000 00 000 000000	REFUND OF PRIOR YR	60,000.00	0.00	0.00	0.00	16,102.55	43,897.45	73.16
10 R 1970 0000 00 000 000000	DR ED FEES	40,000.00	1,550.00	0.00	0.00	6,350.00	33,650.00	84.13
10 R 1971 0000 00 000 000000	SUMMER DR ED FEES	30,000.00	650.00	0.00	0.00	100.00	29,900.00	99.67
10 R 1993 0000 00 000 000000	WELLNESS CENTER	0.00	0.00	0.00	0.00	0.00	0.00	0.00
10 R 1998 0000 00 000 000000	EDUCATION FOUNDATION	2,500.00	0.00	0.00	0.00	2,500.00	0.00	0.00
10 R 1999 0000 00 000 000000	OTHER-LOCAL SOURCES	200,000.00	2,470.29	0.00	0.00	86,134.14	113,865.86	56.93
10 R 2100 0000 00 000 000000	ECO LAB GRANT	0.00	0.00	0.00	0.00	0.00	0.00	0.00
10 R 2220 0000 00 000 000000	DIST 111 GROUP MEDICAL	0.00	290,949.12	0.00	0.00	-2,333,293.55	2,333,293.55	0.00
10 R 2230 0000 00 000 000000	DIST 111 GROUP DENTAL	0.00	14,600.49	0.00	0.00	-121,316.19	121,316.19	0.00
10 R 2901 0000 00 000 000000	GRUNDY CO EDUCATION TIF	1,559,058.65	0.00	0.00	0.00	1,559,058.65	0.00	0.00
10 R 2902 0000 00 000 000000	GRUNDY CO LEASE TIF	0.00	0.00	0.00	0.00	0.00	0.00	0.00

Revenue Report

Fiscal Year: 2020-2021
Month: March

COUNTY OF GRUNDY SCHOOL DIST 111

Account Number	Account Description	Revised Budget	Monthly Activity	Encumbrance	Pending Activity	Available Funds	Year to Date Activity	Percent of Budget Used
10 R 2903 0000 00 000 0000000	GRUNDY CO SPEC ED TIF	0.00	0.00	0.00	0.00	0.00	0.00	0.00
10 R 3001 0000 00 000 0000000	GENERAL STATE AID	6,044,053.00	549,460.00	0.00	0.00	1,628,336.57	4,415,716.43	73.06
10 R 3002 0000 00 000 0000000	GSA HOLD HARMLESS	0.00	0.00	0.00	0.00	0.00	0.00	0.00
10 R 3030 0000 00 000 0000000	FAST GROWTH GRANTS	0.00	0.00	0.00	0.00	0.00	0.00	0.00
10 R 3099 0000 00 000 0000000	TRANSITION ASSISTANCE	0.00	0.00	0.00	0.00	0.00	0.00	0.00
10 R 3100 0000 00 000 0000000	SPEC ED-PRIVATE	550,000.00	0.00	0.00	0.00	20,875.89	529,124.11	96.20
10 R 3105 0000 00 000 0000000	SPEC ED- EXTRAORDINARY	0.00	0.00	0.00	0.00	0.00	0.00	0.00
10 R 3110 0000 00 000 0000000	SPEC ED- PERSONNEL	0.00	0.00	0.00	0.00	0.00	0.00	0.00
10 R 3120 0000 00 000 0000000	SPEC ED-	6,000.00	0.00	0.00	0.00	-71,283.61	77,283.61	1,288.06
10 R 3130 0000 00 000 0000000	SP ED ORPHANAGE SUMMER	0.00	0.00	0.00	0.00	0.00	0.00	0.00
10 R 3145 0000 00 000 0000000	SPEC ED- SUMMER SCHOOL	0.00	0.00	0.00	0.00	0.00	0.00	0.00
10 R 3215 0000 00 000 0000000	VOC ED-FORMULA	0.00	0.00	0.00	0.00	0.00	0.00	302.00
10 R 3220 0000 00 000 0000000	CAREER/TECH EDUC IMPR	68,000.00	0.00	0.00	0.00	-29.00	68,029.00	100.04
10 R 3225 0000 00 000 0000000	VOC ED FORMULA REIMB.	0.00	0.00	0.00	0.00	0.00	0.00	0.00
10 R 3226 0000 00 000 0000000	VOC ED PROGRAM	0.00	0.00	0.00	0.00	0.00	0.00	0.00
10 R 3235 0000 00 000 0000000	VOC ED AG EDUC	4,000.00	0.00	0.00	0.00	4,000.00	0.00	0.00
10 R 3305 0000 00 000 0000000	BILINGUAL ED-DOWNSTATE	0.00	0.00	0.00	0.00	0.00	0.00	0.00
10 R 3350 0000 00 000 0000000	GIFTED EDUCATION	0.00	0.00	0.00	0.00	0.00	0.00	0.00
10 R 3360 0000 00 000 0000000	STATE FREE LUNCH &	1,000.00	0.00	0.00	0.00	766.92	233.08	23.31
10 R 3370 0000 00 000 0000000	DRIVERS ED	70,000.00	0.00	0.00	18909.46	6,366.72	44,723.82	63.89
10 R 3610 0000 00 000 0000000	LEARNING IMPR-CHANGE	0.00	0.00	0.00	0.00	0.00	0.00	0.00
10 R 3640 0000 00 000 0000000	PROF DEVELOP BLOCK	0.00	0.00	0.00	0.00	0.00	0.00	0.00
10 R 3696 0000 00 000 0000000	REGIONAL SAFE SCHOOLS	60,000.00	0.00	0.00	0.00	0.00	60,000.00	100.00
10 R 3740 0000 00 000 0000000	CRIM BACKGROUND CHECKS	0.00	0.00	0.00	0.00	0.00	0.00	0.00
10 R 3775 0000 00 000 0000000	ADA SAFETY BLOCK GRANT	0.00	0.00	0.00	0.00	0.00	0.00	0.00
10 R 3781 0000 00 000 0000000	TECH INTEGRATION GRANT	0.00	0.00	0.00	0.00	0.00	0.00	0.00
10 R 3792 0000 00 000 0000000	TECH-CLOSING THE GAP	0.00	0.00	0.00	0.00	0.00	0.00	0.00
10 R 3800 0000 00 000 0000000	STATE LIBRARY GRANT	0.00	0.00	0.00	0.00	0.00	0.00	0.00

Revenue Report

Fiscal Year: 2020-2021
Month: March

COUNTY OF GRUNDY SCHOOL DIST 111

Account Number	Account Description	Revised Budget	Monthly Activity	Encumbrance	Pending Activity	Available Funds	Year to Date Activity	Percent of Budget Used
10 R 3998 0000 00 000 000000	RECEIPTS/REVENUE ON	0.00	0.00	0.00	0.00	0.00	0.00	0.00
10 R 3999 0000 00 000 000000	OTH GRANTS-IN-AID/STATE	0.00	0.00	0.00	0.00	-80,704.00	80,704.00	0.00
10 R 4100 0000 00 000 000000	TITLE V	0.00	0.00	0.00	0.00	0.00	0.00	0.00
10 R 4101 0000 00 000 000000	HOMELESS GRANT	0.00	0.00	0.00	0.00	0.00	0.00	0.00
10 R 4215 0000 00 000 000000	SPECIAL MILK PROGRAM	500.00	65,893.68	0.00	0.00	-185,103.07	185,603.07	37,120.61
10 R 4300 0000 00 000 000000	TITLE I	170,000.00	0.00	0.00	27414.00	47,103.00	95,483.00	56.17
10 R 4400 0000 00 000 000000	TITLE IV DRUG FREE	0.00	0.00	0.00	0.00	0.00	0.00	0.00
10 R 4620 0000 00 000 000000	SPEC ED-IDEA FLOW THRU	216,000.00	0.00	0.00	0.00	172,524.63	43,475.37	20.13
10 R 4625 0000 00 000 000000	SPEC ED-IDEA-RM & BOARD	160,000.00	230,714.00	0.00	0.00	-169,498.94	329,498.94	205.94
10 R 4745 0000 00 000 000000	AG EDUC GRANT	0.00	0.00	0.00	0.00	0.00	0.00	0.00
10 R 4850 0000 00 000 000000	ARRA - GENERAL STATE	0.00	0.00	0.00	0.00	0.00	0.00	0.00
10 R 4870 0000 00 000 000000	ARRA -GSA-SFSF	0.00	0.00	0.00	0.00	0.00	0.00	303.00
10 R 4880 0000 00 000 000000	ARRA-Educ Jobs Fund	0.00	0.00	0.00	0.00	0.00	0.00	0.00
10 R 4930 0000 00 000 000000	TITLE II EISENHWR PROF	0.00	0.00	0.00	0.00	0.00	0.00	0.00
10 R 4932 0000 00 000 000000	Title II - Teacher	70,000.00	23,792.00	0.00	9543.00	617.00	59,840.00	85.49
10 R 4935 0000 00 000 000000	TITLE II EISENHWR	0.00	0.00	0.00	0.00	0.00	0.00	0.00
10 R 4971 0000 00 000 000000	TITLE II PART D TECH	0.00	0.00	0.00	0.00	0.00	0.00	0.00
10 R 4991 0000 00 000 000000	MEDICAID/ADMN OUTREACH	15,000.00	5,401.64	0.00	0.00	6,962.63	8,037.37	53.58
10 R 4992 0000 00 000 000000	MEDICAID MATCHING	0.00	0.00	0.00	0.00	0.00	0.00	0.00
10 R 7110 0000 00 000 000000	PERM TRANS FROM W/C-	0.00	0.00	0.00	0.00	0.00	0.00	0.00
10 R 7180 0000 00 000 000000	PERM TRANS FROM W/C-	0.00	0.00	0.00	0.00	0.00	0.00	0.00
10 R 7900 0000 00 000 000000	DEBT PROCEEDS	0.00	0.00	0.00	0.00	0.00	0.00	0.00
10 R 9601 0000 00 000 000000	TIF SURPLUS DONATION	0.00	0.00	0.00	0.00	0.00	0.00	0.00
10 - - - - -	Education Fund	31,101,563.90	1,249,944.67	0.00	55723.51	7,469,314.46	23,576,525.93	
11 R 1799 0000 00 000 000000	ACTIVITY FUND ACCOUNT	250,000.00	0.00	0.00	0.00	250,000.00	0.00	0.00
11 R 1799 0000 01 000 900000	COADY SCHOLARSHIP	0.00	6.82	0.00	0.00	-1,042.37	1,042.37	0.00
11 R 1799 0000 30 300 910001	SPORTS - ATHLETIC HALL	0.00	0.00	0.00	0.00	0.00	0.00	0.00
11 R 1799 0000 30 300 910002	SPORTS - ATHLETIC POP	0.00	6.35	0.00	0.00	-5,367.08	5,367.08	0.00

Revenue Report

Fiscal Year: 2020-2021
Month: March

COUNTY OF GRUNDY SCHOOL DIST 111

Account Number	Account Description	Revised Budget	Monthly Activity	Encumbrance	Pending Activity	Available Funds	Year to Date Activity	Percent of Budget Used
11 R 1799 0000 30 300 910003	SPORTS - ATHLETIC	0.00	0.00	0.00	0.00	0.00	0.00	0.00
11 R 1799 0000 30 300 910004	SPORTS - BASEBALL	0.00	0.00	0.00	0.00	-500.00	500.00	0.00
11 R 1799 0000 30 300 910005	SPORTS - BOYS	0.00	0.00	0.00	0.00	-1,912.00	1,912.00	0.00
11 R 1799 0000 30 300 910006	SPORTS - BOYS BOWLING	0.00	0.00	0.00	0.00	-400.00	400.00	0.00
11 R 1799 0000 30 300 910007	SPORTS - BOYS GOLF	0.00	0.00	0.00	0.00	-400.00	400.00	0.00
11 R 1799 0000 30 300 910008	SPORTS - BOYS SOCCER	0.00	0.00	0.00	0.00	-6,761.61	6,761.61	0.00
11 R 1799 0000 30 300 910009	SPORTS - BOYS TENNIS	0.00	0.00	0.00	0.00	0.00	0.00	0.00
11 R 1799 0000 30 300 910010	SPORTS - BOYS TRACK	0.00	0.00	0.00	0.00	-960.00	960.00	0.00
11 R 1799 0000 30 300 910011	SPORTS - BOYS	0.00	0.00	0.00	0.00	-400.00	400.00	0.00
11 R 1799 0000 30 300 910012	SPORTS - CHEERLEADERS	0.00	0.00	0.00	0.00	-19,796.53	19,796.53	0.00
11 R 1799 0000 30 300 910013	SPORTS - CROSS COUNTY	0.00	0.00	0.00	0.00	-4,089.75	4,089.75	0.00
11 R 1799 0000 30 300 910014	SPORTS - FOOTBALL	0.00	0.00	0.00	0.00	-11,415.50	11,415.50	304.00
11 R 1799 0000 30 300 910015	SPORTS - FOOTBALL	0.00	0.00	0.00	0.00	0.00	0.00	0.00
11 R 1799 0000 30 300 910016	SPORTS - GIRLS	0.00	0.00	0.00	0.00	-270.00	270.00	0.00
11 R 1799 0000 30 300 910017	SPORTS - GIRLS BOWLING	0.00	0.00	0.00	0.00	0.00	0.00	0.00
11 R 1799 0000 30 300 910018	SPORTS - GIRLS GOLF	0.00	0.00	0.00	0.00	-400.00	400.00	0.00
11 R 1799 0000 30 300 910019	SPORTS - GIRLS SOCCER	0.00	0.00	0.00	0.00	3,866.61	-3,866.61	0.00
11 R 1799 0000 30 300 910020	SPORTS - GIRLS TENNIS	0.00	0.00	0.00	0.00	-915.00	915.00	0.00
11 R 1799 0000 30 300 910021	SPORTS - GIRLS TRACK	0.00	0.00	0.00	0.00	-300.00	300.00	0.00
11 R 1799 0000 30 300 910022	SPORTS - GIRLS	0.00	0.00	0.00	0.00	-3,710.00	3,710.00	0.00
11 R 1799 0000 30 300 910023	SPORTS - LACROSSE	0.00	0.00	0.00	0.00	-100.00	100.00	0.00
11 R 1799 0000 30 300 910024	SPORTS - OUTDOOR ED	0.00	0.00	0.00	0.00	0.00	0.00	0.00
11 R 1799 0000 30 300 910025	SPORTS - POMS	0.00	300.00	0.00	0.00	-8,182.50	8,182.50	0.00
11 R 1799 0000 30 300 910026	SPORTS - SOFTBALL	0.00	0.00	0.00	0.00	-500.00	500.00	0.00
11 R 1799 0000 30 300 910027	SPORTS - SWIMMING B&G	0.00	0.00	0.00	0.00	-300.00	300.00	0.00
11 R 1799 0000 30 300 910028	SPORTS - WRESTLING	0.00	0.00	0.00	0.00	-400.00	400.00	0.00
11 R 1799 0000 30 300 910029	SUMMER CAMPS - BAND	0.00	0.00	0.00	0.00	0.00	0.00	0.00
11 R 1799 0000 30 300 910030	SUMMER CAMPS - BASEBALL	0.00	0.00	0.00	0.00	0.00	0.00	0.00

Revenue Report

Fiscal Year: 2020-2021
Month: March

COUNTY OF GRUNDY SCHOOL DIST 111

Account Number	Account Description	Revised Budget	Monthly Activity	Encumbrance	Pending Activity	Available Funds	Year to Date Activity	Percent of Budget Used
11 R 1799 0000 30 300 910031	SUMMER CAMPS - BOYS	0.00	0.00	0.00	0.00	0.00	0.00	0.00
11 R 1799 0000 30 300 910032	SUMMER CAMPS - BOYS	0.00	0.00	0.00	0.00	0.00	0.00	0.00
11 R 1799 0000 30 300 910033	SUMMER CAMPS -	0.00	0.00	0.00	0.00	0.00	0.00	0.00
11 R 1799 0000 30 300 910034	SUMMER CAMPS - CROSS	0.00	0.00	0.00	0.00	0.00	0.00	0.00
11 R 1799 0000 30 300 910035	SUMMER CAMPS - FOOTBALL	0.00	0.00	0.00	0.00	0.00	0.00	0.00
11 R 1799 0000 30 300 910036	SUMMER CAMPS - GIRLS	0.00	0.00	0.00	0.00	0.00	0.00	0.00
11 R 1799 0000 30 300 910037	SUMMER CAMPS - GIRLS	0.00	0.00	0.00	0.00	0.00	0.00	0.00
11 R 1799 0000 30 300 910038	SUMMER CAMPS - POMS	0.00	0.00	0.00	0.00	0.00	0.00	0.00
11 R 1799 0000 30 300 910039	SUMMER CAMPS - SOCCER	0.00	0.00	0.00	0.00	0.00	0.00	0.00
11 R 1799 0000 30 300 910040	SUMMER CAMPS -	0.00	0.00	0.00	0.00	0.00	0.00	0.00
11 R 1799 0000 30 300 910041	SUMMER CAMPS - TENNIS	0.00	0.00	0.00	0.00	0.00	0.00	0.00
11 R 1799 0000 30 300 910042	SUMMER CAMPS - WOMENS	0.00	0.00	0.00	0.00	0.00	0.00	305.00
11 R 1799 0000 70 300 900001	ACTIVITIES - POP	0.00	16.14	0.00	0.00	-455.46	455.46	0.00
11 R 1799 0000 70 300 900002	ACTIVITIES - ART CLUB	0.00	0.00	0.00	0.00	0.00	0.00	0.00
11 R 1799 0000 70 300 900003	ACTIVITIES - ATHLETIC	0.00	0.00	0.00	0.00	0.00	0.00	0.00
11 R 1799 0000 70 300 900004	ACTIVITIES - BAND	0.00	0.00	0.00	0.00	0.00	0.00	0.00
11 R 1799 0000 70 300 900005	ACTIVITIES - CHESS	0.00	0.00	0.00	0.00	0.00	0.00	0.00
11 R 1799 0000 70 300 900006	ACTIVITIES - CHOIR	0.00	0.00	0.00	0.00	0.00	0.00	0.00
11 R 1799 0000 70 300 900007	ACTIVITIES - CHORUS	0.00	0.00	0.00	0.00	-1,613.78	1,613.78	0.00
11 R 1799 0000 70 300 900008	ACTIVITIES - CLASS OF	0.00	0.00	0.00	0.00	0.00	0.00	0.00
11 R 1799 0000 70 300 900009	ACTIVITIES - CLASS OF	0.00	0.00	0.00	0.00	0.00	0.00	0.00
11 R 1799 0000 70 300 900010	ACTIVITIES - CLASS OF	0.00	1.06	0.00	0.00	-8.93	8.93	0.00
11 R 1799 0000 70 300 900011	ACTIVITIES - CLASS OF	0.00	1.06	0.00	0.00	-8.93	8.93	0.00
11 R 1799 0000 70 300 900012	ACTIVITIES - CLASS OF	0.00	0.00	0.00	0.00	0.00	0.00	0.00
11 R 1799 0000 70 300 900013	ACTIVITIES - CLASS OF	0.00	0.00	0.00	0.00	0.00	0.00	0.00
11 R 1799 0000 70 300 900014	ACTIVITIES - COMMUNITY	0.00	0.00	0.00	0.00	0.00	0.00	0.00
11 R 1799 0000 70 300 900015	ACTIVITIES - CULINARY	0.00	0.00	0.00	0.00	0.00	0.00	0.00
11 R 1799 0000 70 300 900016	ACTIVITIES - DEBATE	0.00	0.00	0.00	0.00	0.00	0.00	0.00

Revenue Report

Fiscal Year: 2020-2021
Month: March

COUNTY OF GRUNDY SCHOOL DIST 111

Account Number	Account Description	Revised Budget	Monthly Activity	Encumbrance	Pending Activity	Available Funds	Year to Date Activity	Percent of Budget Used
11 R 1799 0000 70 300 900017	ACTIVITIES - DREAM	0.00	0.00	0.00	0.00	0.00	0.00	0.00
11 R 1799 0000 70 300 900018	ACTIVITIES - FASHION	0.00	0.00	0.00	0.00	0.00	0.00	0.00
11 R 1799 0000 70 300 900019	ACTIVITIES - FCCLA	0.00	0.00	0.00	0.00	0.00	0.00	0.00
11 R 1799 0000 70 300 900020	ACTIVITIES - FFA	0.00	0.00	0.00	0.00	-172.50	172.50	0.00
11 R 1799 0000 70 300 900021	ACTIVITIES - FRENCH NHS	0.00	0.00	0.00	0.00	0.00	0.00	0.00
11 R 1799 0000 70 300 900022	ACTIVITIES - FUTURE	0.00	0.00	0.00	0.00	0.00	0.00	0.00
11 R 1799 0000 70 300 900023	ACTIVITIES - I.O.T.A.	0.00	0.00	0.00	0.00	-90.00	90.00	0.00
11 R 1799 0000 70 300 900024	ACTIVITIES - INDIAN	0.00	0.00	0.00	0.00	0.00	0.00	0.00
11 R 1799 0000 70 300 900025	ACTIVITIES - INDIAN	0.00	0.00	0.00	0.00	0.00	0.00	0.00
11 R 1799 0000 70 300 900026	ACTIVITIES - INT'L CLUB	0.00	0.00	0.00	0.00	0.00	0.00	0.00
11 R 1799 0000 70 300 900027	ACTIVITIES - INT'L	0.00	0.00	0.00	0.00	70.00	-70.00	0.00
11 R 1799 0000 70 300 900028	ACTIVITIES - INTERACT	0.00	0.00	0.00	0.00	0.00	0.00	306.00
11 R 1799 0000 70 300 900029	ACTIVITIES - INVESTMENT	0.00	0.00	0.00	0.00	0.00	0.00	0.00
11 R 1799 0000 70 300 900030	ACTIVITIES - JUDO	0.00	0.00	0.00	0.00	0.00	0.00	0.00
11 R 1799 0000 70 300 900031	ACTIVITIES -	0.00	0.00	0.00	0.00	0.00	0.00	0.00
11 R 1799 0000 70 300 900032	ACTIVITIES - MAC	0.00	0.00	0.00	0.00	-2,730.00	2,730.00	0.00
11 R 1799 0000 70 300 900033	ACTIVITIES - MATH TEAM	0.00	0.00	0.00	0.00	0.00	0.00	0.00
11 R 1799 0000 70 300 900034	ACTIVITIES - MCHS BOOK	0.00	0.00	0.00	0.00	0.00	0.00	0.00
11 R 1799 0000 70 300 900035	ACTIVITIES - MEMORIAL	0.00	0.00	0.00	0.00	0.00	0.00	0.00
11 R 1799 0000 70 300 900036	ACTIVITIES - MUSICAL	0.00	0.00	0.00	0.00	-1,116.23	1,116.23	0.00
11 R 1799 0000 70 300 900037	ACTIVITIES - NEEDY	0.00	0.00	0.00	0.00	0.00	0.00	0.00
11 R 1799 0000 70 300 900038	ACTIVITIES - NHS	0.00	0.00	0.00	0.00	-3,135.00	3,135.00	0.00
11 R 1799 0000 70 300 900039	ACTIVITIES - ORCHESIS	0.00	0.00	0.00	0.00	0.00	0.00	0.00
11 R 1799 0000 70 300 900040	ACTIVITIES - PAC	0.00	0.00	0.00	0.00	-1,087.80	1,087.80	0.00
11 R 1799 0000 70 300 900041	ACTIVITIES - PERCUSSION	0.00	0.00	0.00	0.00	0.00	0.00	0.00
11 R 1799 0000 70 300 900042	ACTIVITIES - POKEMON	0.00	0.00	0.00	0.00	0.00	0.00	0.00
11 R 1799 0000 70 300 900043	ACTIVITIES - PPC	0.00	0.00	0.00	0.00	0.00	0.00	0.00
11 R 1799 0000 70 300 900044	ACTIVITIES - SADD	0.00	0.00	0.00	0.00	0.00	0.00	0.00

Revenue Report

Fiscal Year: 2020-2021
Month: March

COUNTY OF GRUNDY SCHOOL DIST 111

Account Number	Account Description	Revised Budget	Monthly Activity	Encumbrance	Pending Activity	Available Funds	Year to Date Activity	Percent of Budget Used
11 R 1799 0000 70 300 900045	ACTIVITIES - SCHOLASTIC	0.00	0.00	0.00	0.00	0.00	0.00	0.00
11 R 1799 0000 70 300 900046	ACTIVITIES - SPANISH NHS	0.00	0.00	0.00	0.00	-485.00	485.00	0.00
11 R 1799 0000 70 300 900047	ACTIVITIES - SPEECH	0.00	0.00	0.00	0.00	0.00	0.00	0.00
11 R 1799 0000 70 300 900048	ACTIVITIES - STUDENT	0.00	0.00	0.00	0.00	-430.00	430.00	0.00
11 R 1799 0000 70 300 900049	ACTIVITIES - TSA	0.00	0.00	0.00	0.00	-1,049.00	1,049.00	0.00
11 R 1799 0000 70 300 900050	ACTIVITIES - UNDERWATER	0.00	0.00	0.00	0.00	0.00	0.00	0.00
11 R 1799 0000 70 300 900051	ACTIVITIES -	0.00	0.00	0.00	0.00	-755.00	755.00	0.00
11 R 1799 0000 70 300 900052	ACTIVITIES - WYSE	0.00	0.00	0.00	0.00	0.00	0.00	0.00
11 R 1799 0000 70 300 900053	ACTIVITIES - YEARBOOK	0.00	0.00	0.00	0.00	-11,247.30	11,247.30	0.00
11 R 1799 0000 70 300 900054	COADY SCHOLARSHIP	0.00	0.00	0.00	0.00	1,000.00	-1,000.00	0.00
11 R 1799 0000 70 300 900055	CYBRARY	0.00	0.00	0.00	0.00	0.00	0.00	0.00
11 R 1799 0000 70 300 900056	FACULTY POP	0.00	6.36	0.00	0.00	-53.60	53.60	307 0.00
11 R 1799 0000 70 300 900057	PROJECT INDIAN	0.00	0.00	0.00	0.00	0.00	0.00	0.00
11 R 1799 0000 70 300 900058	PROM	0.00	0.00	0.00	0.00	0.00	0.00	0.00
11 R 1799 0000 70 300 900059	SCHOLARSHIP	0.00	500.00	0.00	0.00	-4,000.00	4,000.00	0.00
11 R 1799 0000 70 300 900060	TV PRODUCTION	0.00	0.00	0.00	0.00	0.00	0.00	0.00
11 - - - - -	Activity Fund	250,000.00	837.79	0.00	0.00	158,375.74	91,624.26	
20 R 1110 0000 00 000 000000	PRIOR YEAR TAXES	0.00	0.00	0.00	0.00	0.00	0.00	0.00
20 R 1111 0000 00 000 000000	GRUNDY CO TAXES	1,356,090.00	0.00	0.00	0.00	-191,644.32	1,547,734.32	114.13
20 R 1112 0000 00 000 000000	KENDALL CO TAXES	212,487.76	0.00	0.00	0.00	936.10	211,551.66	99.56
20 R 1113 0000 00 000 000000	WILL CO TAXES	985,106.59	0.00	0.00	0.00	14,479.42	970,627.17	98.53
20 R 1114 0000 00 000 000000	GRUNDY CO EDPA SURPLUS	0.00	0.00	0.00	0.00	0.00	0.00	0.00
20 R 1122 0000 00 000 000000	KENDALL CO - EARLY	226,355.36	0.00	0.00	0.00	226,355.36	0.00	0.00
20 R 1123 0000 00 000 000000	WILL CO - EARLY DISTR	1,093,887.50	0.00	0.00	0.00	1,093,887.50	0.00	0.00
20 R 1210 0000 00 000 000000	MOBILE HOME TAX	0.00	0.00	0.00	0.00	0.00	0.00	0.00
20 R 1211 0000 00 000 000000	GRUNDY CO TORT	0.00	0.00	0.00	0.00	0.00	0.00	0.00
20 R 1212 0000 00 000 000000	KENDALL CO TORT	0.00	0.00	0.00	0.00	0.00	0.00	0.00
20 R 1213 0000 00 000 000000	WILL CO TORT	0.00	0.00	0.00	0.00	0.00	0.00	0.00

Revenue Report

Fiscal Year: 2020-2021
Month: March

COUNTY OF GRUNDY SCHOOL DIST 111

Account Number	Account Description	Revised Budget	Monthly Activity	Encumbrance	Pending Activity	Available Funds	Year to Date Activity	Percent of Budget Used
20 R 1222 0000 00 000 0000000	KENDALL CO TORT-EARLY	0.00	0.00	0.00	0.00	0.00	0.00	0.00
20 R 1223 0000 00 000 0000000	WILL CO TORT-EARLY	0.00	0.00	0.00	0.00	0.00	0.00	0.00
20 R 1230 0000 00 000 0000000	CPprt	161,568.00	11,563.88	0.00	0.00	36,388.80	125,179.20	77.48
20 R 1290 0000 00 000 0000000	ESCROW PMTS/LIEU OF	0.00	0.00	0.00	0.00	0.00	0.00	0.00
20 R 1311 0000 00 000 0000000	GRUNDY CO LEASE	0.00	0.00	0.00	0.00	0.00	0.00	0.00
20 R 1312 0000 00 000 0000000	KENDALL CO LEASE	0.00	0.00	0.00	0.00	0.00	0.00	0.00
20 R 1313 0000 00 000 0000000	WILL CO LEASE	0.00	0.00	0.00	0.00	0.00	0.00	0.00
20 R 1322 0000 00 000 0000000	KENDALL CO LEASE-EARLY	0.00	0.00	0.00	0.00	0.00	0.00	0.00
20 R 1323 0000 00 000 0000000	WILL CO LEASE-EARLY	0.00	0.00	0.00	0.00	0.00	0.00	0.00
20 R 1510 0000 00 000 0000000	CHECKING INTEREST	0.00	0.00	0.00	0.00	0.00	0.00	0.00
20 R 1511 0000 00 000 0000000	INVESTMENT INTEREST	40,000.00	636.92	0.00	0.00	37,211.44	2,788.56	6.97
20 R 1910 0000 00 000 0000000	CLASSROOM RENTAL	0.00	0.00	0.00	0.00	0.00	0.00	308.00
20 R 1911 0000 00 000 0000000	BUILDING RENTAL	2,500.00	0.00	0.00	0.00	2,500.00	0.00	0.00
20 R 1912 0000 00 000 0000000	FARM LEASE PAYMENTS	10,000.00	0.00	0.00	0.00	-52,200.73	62,200.73	622.01
20 R 1950 0000 00 000 0000000	REFUND OF PRIOR YR	0.00	0.00	0.00	0.00	0.00	0.00	0.00
20 R 1991 0000 00 000 0000000	SP ED HOUSING ASSESMENT	0.00	0.00	0.00	0.00	0.00	0.00	0.00
20 R 1996 0000 00 000 0000000	SALE OF CROPS	10,000.00	0.00	0.00	0.00	10,000.00	0.00	0.00
20 R 1997 0000 00 000 0000000	INSURANCE	0.00	0.00	0.00	0.00	0.00	0.00	0.00
20 R 1998 0000 00 000 0000000	SALE OF EQUIPMENT	0.00	0.00	0.00	0.00	0.00	0.00	0.00
20 R 1999 0000 00 000 0000000	OTHER-LOCAL SOURCES	10,000.00	0.00	0.00	0.00	-9,358.97	19,358.97	193.59
20 R 2220 0000 00 000 0000000	DIST 111 GROUP MEDICAL	0.00	16,306.82	0.00	0.00	-149,010.75	149,010.75	0.00
20 R 2230 0000 00 000 0000000	DIST 111 GROUP DENTAL	0.00	944.30	0.00	0.00	-8,791.05	8,791.05	0.00
20 R 2901 0000 00 000 0000000	GRUNDY CO TIF EXT	0.00	0.00	0.00	0.00	0.00	0.00	0.00
20 R 3925 0000 00 000 0000000	SCHOOL MAINTENANCE	0.00	0.00	0.00	0.00	0.00	0.00	0.00
20 R 3999 0000 00 000 0000000	OTH GRANTS-IN-AID/STATE	0.00	0.00	0.00	0.00	0.00	0.00	0.00
20 R 4590 0000 00 000 0000000	COPS GRANT - MINOOKA	0.00	0.00	0.00	0.00	0.00	0.00	0.00
20 R 7110 0000 00 000 0000000	PERM TRANS FROM W/C-	0.00	0.00	0.00	0.00	0.00	0.00	0.00
20 R 7130 0000 00 000 0000000	PERM TRANS AMONG FUNDS	0.00	0.00	0.00	0.00	0.00	0.00	0.00

Revenue Report

Fiscal Year: 2020-2021
Month: March

COUNTY OF GRUNDY SCHOOL DIST 111

Account Number	Account Description	Revised Budget	Monthly Activity	Encumbrance	Pending Activity	Available Funds	Year to Date Activity	Percent of Budget Used
20 R 7900 0000 00 000 000000	DEBT PROCEEDS	0.00	0.00	0.00	0.00	0.00	0.00	0.00
20 R 8410 0000 00 000 000000	TAXES PLEDGED/PRINC-CAP	0.00	0.00	0.00	0.00	0.00	0.00	0.00
20 R 9601 0000 00 000 000000	TIF SURPLUS DONATION	0.00	0.00	0.00	0.00	0.00	0.00	0.00
20 - - - - -	Operations & Maint Fund	4,107,995.21	29,451.92	0.00	0.00	1,010,752.80	3,097,242.41	
30 R 1110 0000 00 000 000000	PRIOR YEAR TAXES	0.00	0.00	0.00	0.00	0.00	0.00	0.00
30 R 1111 0000 00 000 000000	GRUNDY CO TAXES	3,032,977.00	0.00	0.00	0.00	-428,290.21	3,461,267.21	114.12
30 R 1112 0000 00 000 000000	KENDALL CO TAXES	490,830.05	0.00	0.00	0.00	2,153.32	488,676.73	99.56
30 R 1113 0000 00 000 000000	WILL CO TAXES	2,257,962.98	0.00	0.00	0.00	33,058.60	2,224,904.38	98.54
30 R 1114 0000 00 000 000000	GRUNDY CO EPDA SURPLUS	0.00	0.00	0.00	0.00	0.00	0.00	0.00
30 R 1122 0000 00 000 000000	KENDALL CO - EARLY	490,967.95	0.00	0.00	0.00	490,967.95	0.00	0.00
30 R 1123 0000 00 000 000000	WILL CO - EARLY DISTR	2,354,542.02	0.00	0.00	0.00	2,354,542.02	0.00	0.00
30 R 1210 0000 00 000 000000	MOBILE HOME TAX	0.00	0.00	0.00	0.00	0.00	0.00	309.00
30 R 1290 0000 00 000 000000	PAYMENT IN LIEU OF	0.00	0.00	0.00	0.00	0.00	0.00	0.00
30 R 1301 0000 00 000 000000	GRUNDY CO LEASE	0.00	0.00	0.00	0.00	0.00	0.00	0.00
30 R 1302 0000 00 000 000000	KENDALL CO LEASE	0.00	0.00	0.00	0.00	0.00	0.00	0.00
30 R 1303 0000 00 000 000000	WILL CO LEASE	0.00	0.00	0.00	0.00	0.00	0.00	0.00
30 R 1323 0000 00 000 000000	WILL CO LEASE-EARLY	0.00	0.00	0.00	0.00	0.00	0.00	0.00
30 R 1510 0000 00 000 000000	CHECKING INTEREST	0.00	0.00	0.00	0.00	0.00	0.00	0.00
30 R 1511 0000 00 000 000000	INVESTMENT INTEREST	75,000.00	762.47	0.00	0.00	71,274.32	3,725.68	4.97
30 R 1512 0000 00 000 000000	BOND INTEREST	0.00	0.00	0.00	0.00	0.00	0.00	0.00
30 R 1999 0000 00 000 000000	OTHER-LOCAL SOURCES	0.00	0.00	0.00	0.00	0.00	0.00	0.00
30 R 2901 0000 00 000 000000	GRUNDY CO TIF EXT	0.00	0.00	0.00	0.00	0.00	0.00	0.00
30 R 7210 0000 00 000 000000	PRINCIPAL ON BONDS SOLD	0.00	0.00	0.00	0.00	0.00	0.00	0.00
30 R 7220 0000 00 000 000000	PREMIUM ON BONDS SOLD	0.00	0.00	0.00	0.00	0.00	0.00	0.00
30 R 7230 0000 00 000 000000	INTEREST ON BONDS SOLD	0.00	0.00	0.00	0.00	0.00	0.00	0.00
30 R 7400 0000 00 000 000000	TRANS FROM OTHER FUNDS	0.00	0.00	0.00	0.00	0.00	0.00	0.00
30 R 7401 0000 00 000 000000	TRANS FROM OBM LEASE	0.00	0.00	0.00	0.00	0.00	0.00	0.00
30 R 7500 0000 00 000 000000	TRANS FROM OTHER FUNDS	0.00	0.00	0.00	0.00	0.00	0.00	0.00

Revenue Report

Fiscal Year: 2020-2021
Month: March

COUNTY OF GRUNDY SCHOOL DIST 111

Account Number	Account Description	Revised Budget	Monthly Activity	Encumbrance	Pending Activity	Available Funds	Year to Date Activity	Percent of Budget Used
30 R 8990 0000 00 000 000000	DISCOUNT ON BONDS SOLD	0.00	0.00	0.00	0.00	0.00	0.00	0.00
30 R 8991 0000 00 000 000000	REFUNJDED PRINCIPAL	0.00	0.00	0.00	0.00	0.00	0.00	0.00
30 R 8992 0000 00 000 000000	REFUNDED INTEREST	0.00	0.00	0.00	0.00	0.00	0.00	0.00
30 R 9601 0000 00 000 000000	TIF SURPLUS DONATION	0.00	0.00	0.00	0.00	0.00	0.00	0.00
30 - - - - -	Debt Service Fund or	8,702,280.00	762.47	0.00	0.00	2,523,706.00	6,178,574.00	
40 R 1110 0000 00 000 000000	PRIOR YEAR TAXES	0.00	0.00	0.00	0.00	0.00	0.00	0.00
40 R 1111 0000 00 000 000000	GRUNDY CO TAXES	650,923.00	0.00	0.00	0.00	-91,989.47	742,912.47	114.13
40 R 1112 0000 00 000 000000	KENDALL CO TAXES	101,993.69	0.00	0.00	0.00	448.90	101,544.79	99.56
40 R 1113 0000 00 000 000000	WILL CO TAXES	472,861.41	0.00	0.00	0.00	6,975.91	465,885.50	98.52
40 R 1114 0000 00 000 000000	GRUNDY CO EPDA SURPLUS	0.00	0.00	0.00	0.00	0.00	0.00	0.00
40 R 1122 0000 00 000 000000	KENDALL CO-EARLY DISTR	108,650.57	0.00	0.00	0.00	108,650.57	0.00	0.00
40 R 1123 0000 00 000 000000	WILL CO-EARLY DISTR	525,021.13	0.00	0.00	0.00	525,021.13	0.00	310.00
40 R 1210 0000 00 000 000000	MOBILE HOME TAX	0.00	0.00	0.00	0.00	0.00	0.00	0.00
40 R 1211 0000 00 000 000000	GRUNDY CO TORT	0.00	0.00	0.00	0.00	0.00	0.00	0.00
40 R 1212 0000 00 000 000000	KENDALL CO TORT	0.00	0.00	0.00	0.00	0.00	0.00	0.00
40 R 1213 0000 00 000 000000	WILL CO TORT	0.00	0.00	0.00	0.00	0.00	0.00	0.00
40 R 1223 0000 00 000 000000	WILL CO TORT-EARLY	0.00	0.00	0.00	0.00	0.00	0.00	0.00
40 R 1230 0000 00 000 000000	CPPRT	0.00	0.00	0.00	0.00	0.00	0.00	0.00
40 R 1290 0000 00 000 000000	PAYMENT IN LIEU OF	0.00	0.00	0.00	0.00	0.00	0.00	0.00
40 R 1442 0000 00 000 000000	SP ED TRAN OTHER	0.00	0.00	0.00	0.00	0.00	0.00	0.00
40 R 1510 0000 00 000 000000	CHECKING INTEREST	0.00	0.00	0.00	0.00	0.00	0.00	0.00
40 R 1511 0000 00 000 000000	INVESTMENT INTEREST	20,000.00	486.68	0.00	0.00	18,494.83	1,505.17	7.53
40 R 1950 0000 00 000 000000	REFUND OF PRIOR YR	10,000.00	0.00	0.00	0.00	10,000.00	0.00	0.00
40 R 1998 0000 00 000 000000	SALE OF EQUIPMENT	2,000.00	0.00	0.00	0.00	-4,000.00	6,000.00	300.00
40 R 1999 0000 00 000 000000	OTHER-LOCAL SOURCES	0.00	0.00	0.00	0.00	0.00	0.00	0.00
40 R 2220 0000 00 000 000000	DIST 111 GROUP MEDICAL	0.00	10,415.95	0.00	0.00	-67,001.48	67,001.48	0.00
40 R 2230 0000 00 000 000000	DIST 111 GROUP DENTAL	0.00	460.85	0.00	0.00	-2,960.87	2,960.87	0.00
40 R 2901 0000 00 000 000000	GRUNDY CO TIF EXT	0.00	0.00	0.00	0.00	0.00	0.00	0.00

Revenue Report

Fiscal Year: 2020-2021
Month: March

COUNTY OF GRUNDY SCHOOL DIST 111

Account Number	Account Description	Revised Budget	Monthly Activity	Encumbrance	Pending Activity	Available Funds	Year to Date Activity	Percent of Budget Used
40 R 3500 0000 00 000 000000	TRANS - REGULAR REIMB	108,140.00	0.00	0.00	0.00	-52,096.17	160,236.17	148.17
40 R 3505 0000 00 000 000000	TRANS - VOCATIONAL	0.00	0.00	0.00	0.00	0.00	0.00	0.00
40 R 3510 0000 00 000 000000	TRANS-SPEC ED REIMB	751,530.20	0.00	0.00	0.00	80,992.71	670,537.49	89.22
40 R 3999 0000 00 000 000000	OTHER RESTRICTED REV	0.00	0.00	0.00	0.00	0.00	0.00	0.00
40 R 4999 0000 00 000 000000	OTHER RESTRICTED REV	0.00	0.00	0.00	0.00	0.00	0.00	0.00
40 R 7130 0000 00 000 000000	PERM TRANS AMONG FUNDS	0.00	0.00	0.00	0.00	0.00	0.00	0.00
40 R 7140 0000 00 000 000000	INT TRANS FROM	0.00	0.00	0.00	0.00	0.00	0.00	0.00
40 R 9601 0000 00 000 000000	TIF SURPLUS DONATION	0.00	0.00	0.00	0.00	0.00	0.00	0.00
40 - - - - -	Transportation Fund	2,751,120.00	11,363.48	0.00	0.00	532,536.06	2,218,583.94	
50 R 1110 0000 00 000 000000	PRIOR YEAR TAXES	0.00	0.00	0.00	0.00	0.00	0.00	0.00
50 R 1111 0000 00 000 000000	GRUNDY CO IMRF	144,721.00	0.00	0.00	0.00	-20,566.03	165,287.03	114.21
50 R 1112 0000 00 000 000000	KENDALL CO IMRF	23,390.56	0.00	0.00	0.00	65.71	23,324.85	3199.72
50 R 1113 0000 00 000 000000	WILL CO IMRF	107,989.61	0.00	0.00	0.00	1,523.71	106,465.90	98.59
50 R 1114 0000 00 000 000000	GRUNDY CO IMRF EDPA	0.00	0.00	0.00	0.00	0.00	0.00	0.00
50 R 1122 0000 00 000 000000	KENDALL CO-EARLY DISTR	24,989.63	0.00	0.00	0.00	24,989.63	0.00	0.00
50 R 1123 0000 00 000 000000	WILL CO-EARLY DISTR	120,054.67	0.00	0.00	0.00	120,054.67	0.00	0.00
50 R 1210 0000 00 000 000000	MOBILE HOME TAX	0.00	0.00	0.00	0.00	0.00	0.00	0.00
50 R 1211 0000 00 000 000000	MOBILE HOME TAX IMRF	0.00	0.00	0.00	0.00	0.00	0.00	0.00
50 R 1212 0000 00 000 000000	MOBILE HOME TAX SOC SEC	0.00	0.00	0.00	0.00	0.00	0.00	0.00
50 R 1230 0000 00 000 000000	CPprt	0.00	5,781.94	0.00	0.00	-62,589.60	62,589.60	0.00
50 R 1290 0000 00 000 000000	PAYMENT IN LIEU OF	0.00	0.00	0.00	0.00	0.00	0.00	0.00
50 R 1291 0000 00 000 000000	PAYMENT IN LIEU OF	0.00	0.00	0.00	0.00	0.00	0.00	0.00
50 R 1510 0000 00 000 000000	CHECKING INTEREST	0.00	0.00	0.00	0.00	0.00	0.00	0.00
50 R 1511 0000 00 000 000000	INVESTMENT INTEREST	15,000.00	475.19	0.00	0.00	13,412.75	1,587.25	10.58
50 R 1511 0000 00 000 000001	GRUNDY CO SS	180,568.00	0.00	0.00	0.00	-25,574.11	206,142.11	114.16
50 R 1512 0000 00 000 000000	KENDALL CO SS	29,169.46	0.00	0.00	0.00	90.41	29,079.05	99.69
50 R 1513 0000 00 000 000000	WILL CO SS	253,934.17	0.00	0.00	0.00	121,046.08	132,888.09	52.33
50 R 1514 0000 00 000 000000	GRUNDY CO SS EDPA	0.00	0.00	0.00	0.00	0.00	0.00	0.00

Revenue Report

Fiscal Year: 2020-2021
Month: March

COUNTY OF GRUNDY SCHOOL DIST 111

Account Number	Account Description	Revised Budget	Monthly Activity	Encumbrance	Pending Activity	Available Funds	Year to Date Activity	Percent of Budget Used
50 R 1522 0000 00 000 000000	KENDALL CO SS-EARLY	31,146.50	0.00	0.00	0.00	31,146.50	0.00	0.00
50 R 1523 0000 00 000 000000	WILL CO SS-EARLY DISTR	146,744.22	0.00	0.00	0.00	146,744.22	0.00	0.00
50 R 1999 0000 00 000 000000	OTHER-LOCAL SOURCES	0.00	0.00	0.00	0.00	0.00	0.00	0.00
50 R 2901 0000 00 000 000000	GRUNDY CO IMRF TIF	0.00	0.00	0.00	0.00	0.00	0.00	0.00
50 R 2902 0000 00 000 000000	GRUNDY CO SS TIF	0.00	0.00	0.00	0.00	0.00	0.00	0.00
50 R 9601 0000 00 000 000000	TIF SURPLUS DONATION	0.00	0.00	0.00	0.00	0.00	0.00	0.00
50 - - - - -	I.M.R.F./Soc. Sec. Fund	1,077,707.82	6,257.13	0.00	0.00	350,343.94	727,363.88	
60 R 1291 0000 00 000 000000	FACILITIES IMPACT FEES	125,000.00	35,444.82	0.00	0.00	30,197.51	94,802.49	75.84
60 R 1292 0000 00 000 000000	SCHOOL SITE FEES	15,000.00	13,557.00	0.00	0.00	-15,628.19	30,628.19	204.19
60 R 1510 0000 00 000 000000	CHECKING INTEREST	0.00	0.00	0.00	0.00	0.00	0.00	0.00
60 R 1511 0000 00 000 000000	INVESTMENT INTEREST	50,000.00	566.32	0.00	0.00	45,752.86	4,247.14	8.49
60 R 1520 0000 00 000 000000	GAIN/LOSS ON	0.00	0.00	0.00	0.00	0.00	0.00	312 0.00
60 R 1930 0000 00 000 000000	IMPACT FEES	0.00	0.00	0.00	0.00	0.00	0.00	0.00
60 R 1999 0000 00 000 000000	OTHER-LOCAL SOURCES	0.00	0.00	0.00	0.00	0.00	0.00	0.00
60 R 4590 0000 00 000 000000	COPS GRANT - CHANNAHON	0.00	0.00	0.00	0.00	0.00	0.00	0.00
60 R 7110 0000 00 000 000000	PERM TRANS FROM W/C-	0.00	0.00	0.00	0.00	0.00	0.00	0.00
60 R 7210 0000 00 000 000000	PRINCIPAL ON BONDS SOLD	0.00	0.00	0.00	0.00	0.00	0.00	0.00
60 R 7800 0000 00 000 000000	TRANS FROM OTHER FUNDS	0.00	0.00	0.00	0.00	0.00	0.00	0.00
60 - - - - -	Capital Projects Fund	190,000.00	49,568.14	0.00	0.00	60,322.18	129,677.82	
70 R 1110 0000 00 000 000000	PRIOR YEAR TAXES	0.00	0.00	0.00	0.00	0.00	0.00	0.00
70 R 1111 0000 00 000 000000	GRUNDY CO TAXES	271,218.00	0.00	0.00	0.00	-38,328.87	309,546.87	114.13
70 R 1112 0000 00 000 000000	KENDALL CO TAXES	42,496.95	0.00	0.00	0.00	186.61	42,310.34	99.56
70 R 1113 0000 00 000 000000	WILL CO TAXES	197,115.30	0.00	0.00	0.00	2,834.45	194,280.85	98.56
70 R 1114 0000 00 000 000000	GRUNDY CO EDPA SURPLUS	0.00	0.00	0.00	0.00	0.00	0.00	0.00
70 R 1122 0000 00 000 000000	KENDALL CO-EARLY DISTR	45,271.07	0.00	0.00	0.00	45,271.07	0.00	0.00
70 R 1123 0000 00 000 000000	WILL CO-EARLY DISTR	219,020.13	0.00	0.00	0.00	219,020.13	0.00	0.00
70 R 1210 0000 00 000 000000	MOBILE HOME TAX	0.00	0.00	0.00	0.00	0.00	0.00	0.00
70 R 1230 0000 00 000 000000	CPPRT	0.00	1,927.31	0.00	0.00	-20,863.20	20,863.20	0.00

Revenue Report

Fiscal Year: 2020-2021
Month: March

COUNTY OF GRUNDY SCHOOL DIST 111

Account Number	Account Description	Revised Budget	Monthly Activity	Encumbrance	Pending Activity	Available Funds	Year to Date Activity	Percent of Budget Used
70 R 1290 0000 00 000 000000	PAYMENT IN LIEU OF	0.00	0.00	0.00	0.00	0.00	0.00	0.00
70 R 1510 0000 00 000 000000	CHECKING INTEREST	0.00	0.00	0.00	0.00	0.00	0.00	0.00
70 R 1511 0000 00 000 000000	INVESTMENT INTEREST	260,000.00	736.14	0.00	0.00	252,365.42	7,634.58	2.94
70 R 1960 0000 00 000 000000	TIF SURPLUS DONATION	0.00	0.00	0.00	0.00	0.00	0.00	0.00
70 R 1999 0000 99 000 000000	OTHER-LOCAL SOURCES	0.00	0.00	0.00	0.00	0.00	0.00	0.00
70 R 2901 0000 00 000 000000	GRUNDY CO TIF EXT	0.00	0.00	0.00	0.00	0.00	0.00	0.00
70 R 7210 0000 00 000 000000	PRIN ON BONDS SOLD	0.00	0.00	0.00	0.00	0.00	0.00	0.00
70 R 7220 0000 00 000 000000	PREMIUM ON BONDS SOLD	0.00	0.00	0.00	0.00	0.00	0.00	0.00
70 R 8110 0000 00 000 000000	ABATEMENT OF W/C FUND	0.00	0.00	0.00	0.00	0.00	0.00	0.00
70 - - - - - - - - - - - - - - - -	Working Cash Fund	1,035,121.45	2,663.45	0.00	0.00	460,485.61	574,635.84	
80 R 1110 0000 00 000 000000	PRIOR YEAR TAXES	0.00	0.00	0.00	0.00	0.00	0.00	0.00
80 R 1111 0000 00 000 000000	GRUNDY CO TORT	419,845.00	0.00	0.00	0.00	-59,320.97	479,165.97	314.13
80 R 1112 0000 00 000 000000	KENDALL CO TORT	67,911.12	0.00	0.00	0.00	252.66	67,658.46	99.63
80 R 1113 0000 00 000 000000	WILL CO TORT	313,164.62	0.00	0.00	0.00	4,646.63	308,517.99	98.52
80 R 1114 0000 00 000 000000	GRUNDY CO TORT EDPA	0.00	0.00	0.00	0.00	0.00	0.00	0.00
80 R 1122 0000 00 000 000000	KENDALL CO TORT-EARLY	72,433.72	0.00	0.00	0.00	72,433.72	0.00	0.00
80 R 1123 0000 00 000 000000	WILL CO TORT-EARLY	347,649.42	0.00	0.00	0.00	347,649.42	0.00	0.00
80 R 1210 0000 00 000 000000	MOBILE HOME TAX	0.00	0.00	0.00	0.00	0.00	0.00	0.00
80 R 1290 0000 00 000 000000	PAYMENT IN LIEU OF	0.00	0.00	0.00	0.00	0.00	0.00	0.00
80 R 1510 0000 00 000 000000	CHECKING INTEREST	0.00	0.00	0.00	0.00	0.00	0.00	0.00
80 R 1511 0000 00 000 000000	INVESTMENT INTEREST	11,000.00	454.37	0.00	0.00	9,671.85	1,328.15	12.07
80 R 1960 0000 00 000 000000	TIF SURPLUS DONATION	0.00	0.00	0.00	0.00	0.00	0.00	0.00
80 R 1999 0000 00 000 000000	OTHER-LOCAL SOURCES	0.00	0.00	0.00	0.00	0.00	0.00	0.00
80 R 2220 0000 00 000 000000	DIST 111 GROUP MEDICAL	0.00	9,057.84	0.00	0.00	-120,989.96	120,989.96	0.00
80 R 2230 0000 00 000 000000	DIST 111 GROUP DENTAL	0.00	208.60	0.00	0.00	-1,049.89	1,049.89	0.00
80 R 2901 0000 00 000 000000	GRUNDY CO TIF EXT	0.00	0.00	0.00	0.00	0.00	0.00	0.00
80 R 4008 0000 00 000 000000	COPS GRANT CHANNAHON	0.00	0.00	0.00	0.00	0.00	0.00	0.00
80 R 4009 0000 00 000 000000	COPS GRANT MINOOKA	0.00	0.00	0.00	0.00	0.00	0.00	0.00

Revenue Report

Fiscal Year: 2020-2021
Month: March

COUNTY OF GRUNDY SCHOOL DIST 111

Account Number	Account Description	Revised Budget	Monthly Activity	Encumbrance	Pending Activity	Available Funds	Year to Date Activity	Percent of Budget Used
80 R 7130 0000 00 000 000000	TRANS FROM ED TORT	0.00	0.00	0.00	0.00	0.00	0.00	0.00
80 R 7990 0000 00 000 000000	TRANS FROM OBM TORT	0.00	0.00	0.00	0.00	0.00	0.00	0.00
80 - ---- ---- -- --- -----	Tort Immunity and	1,232,003.88	9,720.81	0.00	0.00	253,293.46	978,710.42	
90 R 1110 0000 00 000 000000	PRIOR YEAR TAXES	0.00	0.00	0.00	0.00	0.00	0.00	0.00
90 R 1111 0000 00 000 000000	GRUNDY CO TAXES	271,218.00	0.00	0.00	0.00	-38,328.87	309,546.87	114.13
90 R 1112 0000 00 000 000000	KENDALL CO TAXES	42,496.95	0.00	0.00	0.00	186.61	42,310.34	99.56
90 R 1113 0000 00 000 000000	WILL CO TAXES	197,115.30	0.00	0.00	0.00	2,834.45	194,280.85	98.56
90 R 1114 0000 00 000 000000	GRUNDY CO EDPA SURPLUS	0.00	0.00	0.00	0.00	0.00	0.00	0.00
90 R 1122 0000 00 000 000000	KENDALL CO-EARLY DISTR	45,271.07	0.00	0.00	0.00	45,271.07	0.00	0.00
90 R 1123 0000 00 000 000000	WILL CO-EARLY DISTR	219,020.13	0.00	0.00	0.00	219,020.13	0.00	0.00
90 R 1210 0000 00 000 000000	MOBIL HOME TAX	0.00	0.00	0.00	0.00	0.00	0.00	0.00
90 R 1290 0000 00 000 000000	PAYMENT IN LIEU OF	0.00	0.00	0.00	0.00	0.00	0.00	314 0.00
90 R 1510 0000 00 000 000000	CHECKING INTEREST	0.00	0.00	0.00	0.00	0.00	0.00	0.00
90 R 1511 0000 00 000 000000	INVESTMENT INTEREST	50,000.00	518.47	0.00	0.00	45,936.41	4,063.59	8.13
90 R 1960 0000 00 000 000000	TIF SURPLUS DONATION	0.00	0.00	0.00	0.00	0.00	0.00	0.00
90 R 1999 0000 00 000 000000	OTHER-LOCAL SOURCES	0.00	0.00	0.00	0.00	0.00	0.00	0.00
90 R 2901 0000 00 000 000000	GRUNDY CO TIF EXT	0.00	0.00	0.00	0.00	0.00	0.00	0.00
90 R 7210 0000 00 000 000000	PRIN ON BONDS SOLD	0.00	0.00	0.00	0.00	0.00	0.00	0.00
90 R 7220 0000 00 000 000000	PREMIUM ON BONDS SOLD	0.00	0.00	0.00	0.00	0.00	0.00	0.00
90 - ---- ---- -- --- -----	Fire Prevention &	825,121.45	518.47	0.00	0.00	274,919.80	550,201.65	
Grand Totals:		51,272,913.71	1,361,088.33	0.00	55723.51	13,094,050.05	38,123,140.15	



April 2021

To the Principal/IHSA Official Representative Addressed:

It is time again for your school to renew its membership in the Illinois High School Association. For the 2021-2022 school term the IHSA Board of Directors has approved a membership assessment scaled to your classification enrollment. (By-law 1.441).

Your school may renew membership in the Illinois High School Association by confirming that your school continues to be Recognized by the Illinois State Board of Education and by certifying that your Board of Education/Governing Board has voted to adopt and abide by the Constitution, By-laws, Terms and Conditions, and Administrative Procedures, Guidelines, and Policies of the Association and agreeing to the 2021-2022 membership assessment.

Your 2021-22 membership renewal is due by June 15, 2021. Please do not delay. Obtain your Board of Education's action on the membership resolution and email it to general@ihsa.org or fax (309) 663-7479. Your 2021-22 membership assessment is due by September 1, 2021. An invoice will be available in your Schools Center for the principal or official representative.

Sincerely,

Craig Anderson
Executive Director

**THIS FORM MUST BE SIGNED BELOW, ON THE APPROPRIATE LINE, BY THE PRINCIPAL OR OFFICIAL REPRESENTATIVE AND THE BOARD PRESIDENT OR SECRETARY.
DO NOT DETACH**

To: IHSA Executive Director

We certify that _____ High School is recognized by the Illinois State Board of Education. It is understood that failure to be recognized by the Illinois State Board of Education will disqualify our school for membership in the IHSA and that if this were to occur; it is our responsibility to immediately notify the Association of this change in status.

We further certify our Board of Education/Governing Board, at its meeting held on _____, 2021, voted to renew membership in the Illinois High School Association, and to adopt and abide by the Constitution, By-laws, Terms and Conditions, and Administrative Procedures, Guidelines and Policies of the Illinois High School Association for the year of July 1, 2021, through June 30, 2022.

Principal/Official Representative Signature

Board President or Board Secretary Signature

Print Name and Phone Number

Print Name and Phone Number

_____ High School _____, Illinois

2021-22 Membership Renewal

Return to Learn 2021 Tentative Plans

We are in the process of meeting with stakeholders to determine the best course of action for next school year. Remote learning may be significantly different from the experience MCHS students received this school year. Courses may be offered through an MCHS staff member online, or via Edgenuity, which are online courses that include all lessons and assessments. Our Department Chairs, Instructional Team, Administration and MEA have engaged in meaningful dialogue to help support our students and staff for next school year. Communication to outline our next school year and application are included below:

- ❑ [Return to Learn 2021 Communication](#) (See Below)

Minooka Community High School is returning to full day in-person learning for the 2021-2022 school year. School districts are required by the state to provide the option of remote learning only for students with medical exemptions. If your student has no medical exemptions, no further action is required. According to the Illinois Department of Public Health (IDPH), “Consistent with the updated guidance from the CDC, families of students who are at increased risk of severe illness (including those with special health care needs) or who live with people at increased risk must be given the option of remote instruction.” Remote learning will only be offered to students who meet the IDPH criteria.

Remote learning may be significantly different from the experience MCHS students received this school year. Courses may be offered through an MCHS staff member online, or via Edgenuity, which are online courses that include all lessons and assessments.

If your student meets the IDPH medical criteria related to COVID-19, parents/guardians must complete the application for remote learning. A Remote Learning application can be found here, as well as on our website www.mchs.net. Please complete this form and return to the District Office at South Campus or email to Dawn Lehr, Administrative Assistant to the Director of Curriculum and Instruction, at dlehr@mchs.net.

Please submit your application by Monday, May 10, 2021. If medical documentation cannot be obtained by May 10, please submit the application. Medical documentation will

be due by May 30, 2021. Upon internal review, you will receive notification that your student has been approved or denied for remote learning.

[Remote Learning Application](#) (See Below)

Remote Learning Application (COVID-19 Related)

Minooka Community High School District #111 will do their best to accommodate every student's learning needs. If a parent/guardian believes that attendance by their student through a traditional in person environment would be detrimental to the health or safety of the student or anyone living in the same household, then this form is to be utilized to request remote learning for the student. Please provide as much detail as possible so we can best support your student.

Student Name: _____ Student ID#: _____

Parent/Guardian: _____ Date: _____

Please indicate the reason for your request.

- Student is at increased risk of severe illness
- Student has special health care needs
- Student lives with someone who is at increased risk

Please provide details for your request.

Terms and Conditions:

- I have attached to this form current, signed documentation from a medical professional (*click [here](#) for required medical form*) confirming that remote learning is medically necessary due to the vulnerable health condition of my student or of a family member residing within the same home as my student. This vulnerable health condition must be directly related to COVID-19.
- I understand that MCHS will do their utmost to accommodate my student's learning needs but that some opportunities and courses may need to be modified or not offered in a remote environment.

- I understand that provisions of special education and accommodations for students with individualized education plans (IEPs) or Section 504 plans will be determined by each respective IEP or Section 504 team.
- I understand that if my child is taking courses that are live streamed, their camera must be on and they must be in attendance during the teacher's full lesson, and maintain passing grades in all classes. If attendance is not consistent and grades are failing, my student's placement may be re-evaluated.
- I understand that selecting remote learning for my student is a year-long commitment. A change from remote learning to in-person instruction would require the approval of the Remote Team.
- I understand that my student can participate in extracurricular activities and athletics while being a remote student.
- I understand that my student's final schedule will be available in July during registration days. Any changes to their selected courses will be communicated, as needed.

Parent/Guardian signature:

For office use only

- Request Temporarily Approved (pending appropriate documentation)
- Request Approved
- Request Denied
- Parent Notified
- Director of Curriculum & Instruction and Administrative Assistant Notified
- Transportation Notified
- Counselor, Dean, Social Worker, Case Manager (if applicable) Notified

District #111 Foundation for Educational Excellence

The District #111 Foundation for Educational Excellence met on April 20, 2021. We discussed our annual event that will be held on December 3, 2021. The location will be Chapin's. The board reimbursed MCHS for the purchase of a few grants, and also graciously decided to sponsor a lunch for our staff during Teacher Appreciation Week. The Foundation continues to encourage staff to request grants by utilizing the forms found on the MCHS Website.

Strategic Plan Update

The Goal Leaders held a meeting on March 4, 2021, and have not met as a group since. We will meet one more time in June to review the school year, report progress, and share items of accomplishment since the inception of the plan. We will tentatively schedule to share with the BOE at the June meeting.

Board Policy Review

April (May 4, 2020)

2:100 Conflict of Interest: Board members must annually file a Statement of Economic Interests as required by the Illinois Governmental Ethics Act. Each Board member is responsible for filing the statement with the county clerk of the county in which the District's main office is located by May 1.

You should have received your Conflict of Interest form. Please return to Mrs. Ward.

2:120 New BOE Development: This will need to be completed by members new to the BOE . New Member Development Includes:

- Open Meeting Act (within 90 days of taking oath)
- Mandatory Board Member Training (within first year of the first term)
- Adverse Consequences of School Exclusion-Reasonable Efforts to educate (Mr. Fester)
- Board Self-Evaluation-all-periodic
- New Board Member Orientation-Mr. Brozovich and I will complete
- IASB in-district training will be held on May 17, 2021 at 5:30 PM

4:160 Pest Control

Before pesticides are used on District premises, the Superintendent or designee shall notify employees and parents/guardians of students as required by the Structural Pest Control Act.

This is handled by Mr. Piper

Minooka Community High School District 111
26655 W. Eames St.
Channahon, IL 60410

**INVITATION TO BID ON THE
MINOOKA COMMUNITY HIGH SCHOOL DISTRICT 111
MINOOKA COMMUNITY CONSOLIDATED SCHOOL DISTRICT 201
TRANSPORTATION PARKING LOT DRAINAGE IMPROVEMENTS**

Minooka Community High School District 111 and Minooka Community Consolidated School District 201 are soliciting bids for transportation parking lot drainage improvements. **Deadline for Return is Thursday, April 15, 2021 at 11:00 am. Bids must be mailed to John Troy at 26655 W. Eames Street, Channahon, IL 60410 marked "Transportation Drainage Bid."**

BIDS ARE TO BE SUBMITTED TO

Minooka Community High School District 111
Attn: Mr. John Troy, Assistant Superintendent of Business & General Counsel
26655 W. Eames St.,
Channahon, IL 60410

1. OPENING OF BIDS

Bids must be received by Mr. John Troy, Assistant Superintendent of Business & General Counsel no later than 11 am Thursday, April 15, 2021 at which time they will be opened and acknowledged. Bids will be studied and reviewed and it is anticipated that a recommendation will be made to the Boards of Education at their next regularly scheduled meeting. The Boards of Education reserves the right to waive any informalities, irregularities, or defects in any proposal should it be in the best interest of the school districts to do so.

2. PREPARATION OF PROPOSAL

Proposals will be opened immediately after the deadline. The method of transmittal of the proposal is at the seller's risk of untimely receipt by the Boards. The Districts will not be responsible for delays in delivery due to electronic means. All bids will be acknowledged received, if you submitted a bid and did not receive an acknowledgement contact John Troy at 815-521-4294. Late bids will be returned unopened to the sender.

3. METHODS OF AWARD

The Boards of Education reserves the right to reject any and all bids or to accept a bid in whole or in divisible part if deemed to be in the best interest of the School Districts. The Boards of Education reserves the right to choose alternates it deems to be in the best interest of the School Districts. The Boards of Educations shall have the right and authority to award orders to the bidder or bidders best meeting all specifications and conditions based upon the sole judgment of the Boards.

In making its determination the following qualifications in addition to price will be considered by the Board:

- a. The ability, capacity and skill of the Bidder to perform the service required.
- b. Whether the Bidder can perform the contract or provide the service promptly, or within the time specified, without delay or interference
- c. The character, integrity, reputation, judgment, experience and efficiency of the Bidder.
- d. The quality of performance of previous contracts or services.
- e. The previous and existing compliance by the Bidder with laws and ordinances relating to the contract or service
- f. The sufficiency of the financial resources and ability of the Bidder to perform the contract or provide the service
- g. The quality, availability and adaptability of the supplies, or services, to the particular use required
- h. The ability of the Bidder to provide future maintenance and service for the use of the subject of the contract
- i. Past history and performance that the Bidder may have with the Districts.
- j. Such other information as may be secured having a bearing on the decision to make the award
- k. Consideration will be given to standardization, interchangeability and availability of parts, if applicable to bid.
- l. In determining a bidder's responsiveness, the Boards shall consider material deviations from the advertised specifications which materially affect price, quantity or limit the bidder's liability

Proposers and other interested parties are cordially invited to be present at the public proposal opening to be held at the time the sealed proposals are due. Proposals will be publicly opened and results announced.

4. DURATION AND WITHDRAWAL OF BIDS

All bids shall be binding for 60 calendar days following the bid opening date, unless the bidder, upon request of the Districts, agrees to an extension. A written request for the withdrawal of the bid or any part thereof may be granted if the request is received by the Districts prior to the specified time of bid opening. No bids may be withdrawn after they have been opened.

5. CERTIFICATES & ASSURANCES

All bidders shall submit all certificates herein contained and as required by law.

6. INVOICES

The successful Contractor shall submit two copies of invoices, one to each district. Payment to the contractor shall be made within 30 days after receipt of invoice and approval by the Boards of Education, subject to the terms contained herein. Payments are approved by the Boards of Education at their monthly Board meeting provided a valid invoice is received at least two weeks prior to the Board's meeting and said service has been provided and accepted by the Boards of Education.

7. COMPLETION DELIVERY TIME

All work must be scheduled with the transportation department and must be completed by May 15, 2021.

8. LATE BIDS

Formal bids, amendments thereto, or requests for withdrawal of bids received by the District after the time specified for bid opening will not be considered.

9. PERFORMANCE BOND:

If the bidder's proposal for the project is equal to or great than \$100,000 then the following bonds shall be delivered to the Districts and shall become binding with the acceptance of the bid.

Performance bond satisfactory to the Districts, executed by Surety Company authorized to do business in the state or otherwise secured in a manner satisfactory to the District, in an amount equal to 110% of the price specified.

10. COMPLETENESS

All information required by the Invitation to Bid must be supplied to constitute a proper bid.

11. AUTHORITY TO ACT AS AGENT

Upon request, the bidder will provide proof to the Districts that the signatory on the proposal form has the authority to bind the bidder to the price(s) quoted.

12. DEVIATIONS

In the event that the Bidder intends to deviate from the specifications, all such deviations must be listed and attached to the bid. The absence of a submitted deviations will assure the Districts that no deviations from specifications exist.

13. QUESTIONS REGARDING SPECIFICATIONS

Should a bidder find discrepancies or omissions in the specifications or instructions, or should he/she be in doubt as to their true meaning, he/she should notify the Assistant Superintendent who will, in turn, clarify such specifications and notify other bidders of any material change or clarification. The Boards of Education shall not be held responsible for oral instruction to bidders. **No questions will be accepted 24 hours prior to the bid opening.**

14. SUBLETTING CONTRACT

It is mutually understood and agreed that the Bidder shall not assign, transfer, convey, sublet, or otherwise dispose of his/her contract or right, title or interest therein, or power to execute such contract, to any other person, firm or corporation, without the previous written consent of the Districts, but in no case shall such consent relieve the Bidder from his/her obligation, or change the terms of the Contract.

Furthermore, the contractor shall not allow a subcontractor to commence work on any portion of the project without evidence that the subcontractor has insurance coverage equal to coverages required of the contractor by the districts.

15. NON-DISCRIMINATION

No bidder who is the recipient of the Districts' funds, or proposes to perform any work or furnish any goods under this agreement shall discriminate against any worker, employee or applicant or any member of the

public because of religion, race, sex, color, or national origin, nor otherwise commit any unfair employment practice. Bidder further agrees that this article will be incorporated by the bidder into all contracts entered into with suppliers of materials or services, contractors and subcontractors and all labor organizations furnishing skilled, unskilled, and craft union skilled labor, or who may perform any such labor or services in connection with this contract.

16. SEXUAL HARASSMENT POLICY

Every party to a public contract and every eligible bidder must have a written sexual harassment policy that shall include, at a minimum, the following information: (i) the illegality of sexual harassment; (ii) the definition of sexual harassment under state law; (iii) a description of sexual harassment, utilizing examples; (iv) the recourse, investigative and complain process available through the Illinois Department of Human Rights and the Human Rights Commission; (v) directions on how to contact the Department and Commission; and (vi) protection against retaliation as provided by Section 6-101 of the Human Rights Act.

17. INDEMNITY

Bidder/contractor shall indemnify, keep and save harmless the Districts, its agents, officials and Employees, and Boards of Education, against all injuries, death, loss, damages, claims, patent claims, suits, liabilities, judgments, cost and expenses, which may in any way accrue against the Districts in consequence of the granting of this contract or which in any way result therefrom, whether or not it shall be alleged or determined that the act was caused through negligence or omission of the Contractor or his employees, and the bidder/contractor shall, at his/her own expense, appear, defend and pay all charges of attorneys and all costs and other expenses arising therefrom or incurred in connection therewith, and if any judgment shall be rendered against the Districts in any such action, the bidder/contractor shall, at his/her own expense, satisfy and discharge the same. Bidder/contractor expressly understands and agrees that any performance bond or insurance protection required by this contract, or otherwise provided by bidder, shall in no way limit the responsibility to indemnify, keep or save harmless and defend the Districts as herein provided.

18. COLLUSIVE BIDDING

The bidder certifies that his/her bid is made without any previous understanding, agreement or connection with any person, firm, or corporation making bid for the same project, and is in all respects fair, without outside control, collusion, fraud, or otherwise illegal action.

19. IDENTICAL BIDDING - EXECUTIVE ORDER NO. 10946

All identical bids submitted to the Districts as a result of advertised procurement for materials, supplies, equipment or services exceeding \$2,500.00 in total amount shall, at the discretion of the Districts, be reported to the Attorney General of the United States in accordance with Form DJ-1510 and the Presidential Order dated April 24, 1961 for possible violation and enforcement of antitrust laws.

20. CONTRACTOR NOT AN AGENT

The bidder/contractor shall not be held or deemed in any way to be an agent, employee, or official of the District, but rather an independent contractor furnishing services to the Districts.

21. RESPONSIBILITY FOR MATERIALS SHIPPED

If applicable, the bidder/contractor shall be responsible for all the materials, supplies, and equipment covered by this contract stored on the Districts' site

22. INSPECTIONS

If applicable, for supplies and materials purchases - inspection and acceptance of will be made after delivery. Final inspection shall be conclusive except as regards latent defects, fraud, or such gross mistakes as amount to fraud. Final inspection and acceptance or rejection of the materials or equipment will be made as promptly as practicable, but failure to inspect or accept or reject materials or equipment shall not impose liability on the District for such materials or equipment as are not in accordance with the specifications. All delivered materials shall be accepted subject to inspection and physical count.

Contractors or vendors should be aware that the Districts are required by state law to follow and adhere to all local municipal building and zoning codes.

Work must be inspected by the Village of Minooka and approval obtained prior to any payment.

23. PREVAILING WAGE

The awarded Contractor is required to pay all applicable wage rates as required and stipulated by Federal, State and Local laws and **Contractor agrees to pay prevailing wages for all work completed under this contract.**

The contractor and all subcontractors shall use the "CERTIFIED TRANSCRIPT OF PAYROLL" and "AFFIDAVIT" forms as prepared by the Illinois Department of Labor. Electronic Versions of these forms are available from the Illinois Department of Labor. Pay requests will not be processed until current certified payrolls are provided for contractor and subcontractors. Contractor shall be required to provide waiver/releases and final waiver of liens for contractor and all sub-contractors.

24. INSURANCE

The District upon awarding a project requires a Certificate of Insurance with "Additional Insured Endorsement in such amounts detailed below and as deemed acceptable by the Districts. Proposed insurance limits must be submitted with the proposal. You must require your insurance company to list the Districts as "**Additional Insured**". In the "Description of Operations locations/Vehicles/Special Items" section of the Certificate it must state: "Minooka Community High School District 111, Minooka Community Consolidated District 201, its employees, officers, agents, and their Boards of Education as additional insured per Additional Insured Endorsement.

The following summarizes basic insurance requirements for Contractors. Contractor shall at his expense, procure and maintain required insurance coverages on all its operations in companies acceptable to the Districts.

1. Workers Compensation (Statutory) and Employer's Liability:

\$1,000,000 each accident for bodily injury by accident; \$1,000,000 each employee for bodily injury by disease; \$1,000,000 policy limit for bodily injury by disease.

2. General Liability Insurance (CGL):

Commercial general liability on an occurrence coverage form. The limits of liability shall not be less than:

\$1,000,000 each occurrence (combined single limit for bodily injury and property damage);
\$1,000,000 for personal and advertising injury liability;
\$1,000,000 aggregate on products and completed operations;
\$3,000,000 general aggregate.

Additional Insured Endorsement: Blanket additional insured coverage should be requested to include the Contractor, his officers, directors and employees, the Owner, and any other party, as may be required.

3. **Automobile Liability Insurance:**

4. \$1,000,000 Combined single limit each accident for bodily injury and property damage. Include coverage on all owned, hired, and non-owned automobiles.

5. **Certificates of Insurance:**

6. Contractor shall furnish certificates of Insurance and applicable endorsements to Districts *before* Contractor commences any work.

7. **Insurance Requirements for Sub-Contractors:**

Contractor shall ensure that all tiers of his Sub- Contractors shall maintain insurance in like form and amounts, including the Additional Insured requirements. Each Sub Contractor shall provide Certificates of Insurance and applicable endorsements to the Contractor *prior to the start* of the Sub- Contractor's work on this project.

8. **Acceptance/Compliance:**

The required insurance shall be subject to the approval of the Districts, but any acceptance of insurance certificates by Districts shall in no way limit or relieve Contractor of the duties and responsibilities stipulated in the Contract Agreement. If higher limits or other forms of insurance (e.g., professional liability, aircraft insurance, builders risk, hazardous materials or pollution liability) are required by the Districts, the Contractor will comply with such requirements. Districts may take such steps as necessary to assure Contractor's compliance with insurance requirements. In the event Contractor fails to maintain minimum insurance coverage as required or provide written evidence of required Certificates and/or endorsements, Districts may maintain such coverage and charge the expense to Contractor, terminate this agreement and/or withhold payment.

25. **SAFETY**

The contractor shall provide all barricades, security, and signage necessary to control vehicle and pedestrian traffic and to protect the pavement areas while work is in progress.

26. **GENERAL**

The contractor will be responsible for the procurement of all construction permits. The contractor shall give all notices necessary and incident to the due and lawful prosecution of the Work. The contractor shall be responsible for arranging all necessary inspections with Minooka Village officials.

All work shall be conducted in accordance with the Occupational Safety and Health Administration (OSHA) requirements and Grundy County regulations. The contractor shall be fully responsible for coordination of his work and the work of his employees, subcontractors, and suppliers, and to assure compliance with schedules. The Occupational Safety & Health Administration (OSHA) Hazardous Communication Standard (29 CFR 1910.1200) states that contractors/suppliers must be informed of the hazardous chemicals their

employees may be exposed to while performing their work and any appropriate protective measures. In order to comply with this requirement, the district has developed a list of all the hazardous chemicals known to be present in our facility. A Material Safety Data Sheet (MSDS/SDS) is also on file for each of these chemicals and/or hazardous substances. This information is available to you and to your employees upon request.

In order to protect the safety and health of our own employees as well as the employees of contractors/suppliers, contractor/suppliers must maintain and provide, upon request, an MSDS/SDS on any hazardous chemical(s) or material(s) which they bring to the facility. Failure to maintain an MSDS/SDS and provide this information in a timely manner will result in the removal of the contractor/supplier from the premises.

Each employer is also responsible for notifying any subcontractor they employ regarding the requirements of OSHA's Hazard Communication Standard.

The contractor shall schedule work with the authorized district representative with at least Seven (7) days advance notice. The contractor shall at all times conduct the work in such manner as to insure the least obstruction to vehicular and pedestrian traffic. The convenience of the general public and employees shall be provided for in an adequate and satisfactory manner.

Any unforeseen site conditions that are encountered in the field that warrant a modification in the plans and/or design shall be brought to the attention of the districts' authorized representative.

Any construction items that are not represented in the plans or summary of quantities but can be reasonably be expected to be included in the scope of work of an already specified item shall be considered incidental to the Contract and no additional expense shall be permitted.

It shall be the sole responsibility of the contractor to restore the project or disturbed areas to conditions prior the commencement of construction activities.

To the fullest extent permitted by law, the contractor shall be responsible for any and all injuries or damages to property due to the activities of the contractor, its subcontractors, suppliers, agents and employees arising out of or resulting from performance of the contract, or any activity in connection therewith. The contractor shall indemnify and hold harmless the Districts, including the Boards of Education, its employees, officers and agents from any and all claims, lawsuits, actions, costs and fees, including reasonable attorney's fees and expenses of every nature and description, arising from, growing out of, or connected with the work, or on account of or in consequence of any neglect in safeguarding the work, or on account of or in consequence of using unacceptable materials in construction of the work of because of any act, omission, neglect, or misconduct of contractor, its officers, employees, agents, subcontractors, or anyone directly or indirectly employed by them and/or anyone for whose acts they may be liable for because of any claims or amount of recovered by reason of any infringement of patent, trademark, or copyright, or by reason of the violation of any law, ordinance, order, or decree.

The contractor shall be responsible for meeting any requirement for any machine, device or part thereof, which is regulated by or becomes regulated by Federal or State of Illinois Noise Standards, shall conform to those standards. All other equipment shall operate under the noise requirements of the Village of Minooka and County of Grundy, IL.

Nothing in this contract between the districts and the contractor or anyone else is intended or shall be construed, unless otherwise expressly stated, to reduce the responsibility of the contractor, subcontractor, anyone directly or indirectly employed by them or anyone for whose acts they may be liable, from full and complete supervision and achievement of work place safety. Any inspection of the work conducted by an authorized representative of the districts, employee, or officer whether notice of the results thereof is provided

to anyone or not provided to anyone, shall neither establish any duty on their parts nor create any expectation of duty to anyone, including but not limited to third parties, regarding work place safety.

In order to insure this and other duties of the contractor, certain indemnifications and insure is required by the contract. Additionally, the contractor guarantees to the districts a safe work place shall be provided for all employees of the contractor, subcontractor, anyone directly or indirectly employed by them or anyone for whose acts they may be liable of the applicable standards of the Occupational Safety and Health Act and any work place safety act of the State of Illinois. Contractor agrees to require this work place safety guarantee of all subcontractors and expressly require the districts and Boards of Education to be third party beneficiaries of each guarantee.

**Minooka Community High School District 111
26655 W. Eames Street
Channahon, IL 60410**

SPECIFICATIONS

The Districts' Transportation Barn is located at 700 E. Minooka Road, Minooka, IL 60447. This work is being done in coordination with the development of the property to east of the Districts' transportation barn. The contractor is required to coordinate all work with that operation.

The attached Exhibit A details the work being conducted at Lot 2 – 84 Lumber Subdivision, 692 W. Monamin St. As part of that project page 7 of 14 illustrates (highlited in red box) the work being bid out for the transportation barn drainage improvements.

Bidders are requested to submit a bid for the work described therein.

Please Submit a Certificate of Liability Insurance “Accord” form with Proposed Liability Insurance Limits

**Minooka Community High School District 111
26655 W. Eames Street
Channahon, IL 60410**

**Assurances and Certifications
PART 1**

STATEMENT OF ETHICS CERTIFICATION

By submission of this bid or proposal, the bidder certifies that:

1. This bid or proposal has been independently arrived at without collusion with any other bidder or with any competitor.
2. This bid or proposal has not been knowingly disclosed and will not be knowingly disclosed, prior to the opening of bids or proposals for this project, to any other bidder, competitor or potential competitor.
3. No attempt has been made or will be made to induce any other person, partnership or corporation to submit or not to submit a bid or proposal.
4. Bidder has not been convicted of price fixing nor pleaded “no contest” to such charges within the last five (5) years.
5. Bidder is not subsidiary of a company that has been convicted of price fixing nor pleaded “no contest” to such charges within the last five (5) years.

By: _____
Authorized Agent

SUBSCRIBED and SWORN TO before me

this _____ day of _____, 20 ____

NOTARY PUBLIC

This page must be returned signed and notarized for the bid to be considered.

Minooka Community High School District 111
26655 W. Eames Street
Channahon, IL 60410

Assurances and Certifications PART 2

SUPPLIER'S/CONTRACTOR'S CERTIFICATION

As part of its bid, the supplier/contractor does hereby certify that said supplier/contractor is not barred from bidding on the contract as a result of violation of either Section 33E-3 or 33E-4 of Article 33E of Chapter 38 of the Illinois Revised Statutes.

By: _____
Authorized Agent

CERTIFICATE OF COMPLIANCE WITH ILLINOIS DRUG-FREE WORKPLACE ACT (Suppliers/Contractors with 25 or More Employees)

As part of its bid, the supplier/contractor does hereby certify pursuant to section 3 of the *Illinois Drug-Free Workplace Act (Ill.Rev.Stat. ch 127. para. 132.313)* that [he, she, it] shall provide a drug-free workplace for all employees engaged in the performance or work under the contract by complying with the requirements of the *Illinois Drug-Free Workplace Act* and, further certifies, that [he, she, it] is not ineligible for award of this contract by reason of debarment for a violation of the *Illinois Drug-Free Workplace Act*.

By: _____
Authorized Agent

Does Not Apply (Less than 25 Employees)

By: _____
Authorized Agent

SUBSCRIBED and SWORN TO before me

this _____ day of _____, 20 _____

NOTARY PUBLIC

This page must be returned signed and notarized for the bid to be considered.

**Minooka Community High School District 111
26655 W. Eames Street
Channahon, IL 60410**

**Assurances and Certifications
PART 3**

CERTIFICATE OF COMPLIANCE WITH ILLINOIS HUMAN RIGHTS ACT

Sexual Harassment Policies

As part of its bid, the supplier/contractor does hereby certify pursuant to 775 ILCS 5/2-105 that [he, she, it] has written sexual harassment policies that include at least the minimum information as required by law; that a copy of the policies shall be provided to the Department of Human Rights upon request; and that [he, she, it] is not ineligible for award of this contract by reason of debarment for a violation of the *Illinois Human Rights Act*.

By: _____
Authorized Agent

Equal Employment Opportunity

As part of its bid, the supplier/contractor does hereby certify pursuant to 775 ILCS 5/2-104 that [he, she, it] complies with the procedures and requirement of the Illinois Department of Human Rights regulations concerning equal employment opportunities and affirmative action, shall provide such information with respect to its employees and applicants for employment and assistance as the Department may reasonably request, and that [he, she, it] is not ineligible for award of this contract by reason of debarment for a violation of the *Illinois Human Rights Act*.

By: _____
Authorized Agent

SUBSCRIBED and SWORN TO before me

this _____ day of _____, 20 ____

NOTARY PUBLIC

This page must be returned signed and notarized for the bid to be considered.

EXHIBIT A

FINAL ENGINEERING PLANS
for

LOT 2 - 84 LUMBER SUBDIVISION
692 W. MONAMIN ST
MINOOKA, ILLINOIS

PROJECT NO:10942

DRAINAGE STATEMENT

I, JASON E. WIESBROCK, TO THE BEST OF MY KNOWLEDGE AND BELIEF, HAVE PREPARED THE ABOVE ENGINEERING PLANS AND SPECIFICATIONS FOR THE PROJECT DESCRIBED HEREIN. I AM A REGISTERED PROFESSIONAL ENGINEER IN THE STATE OF ILLINOIS AND I AM NOT PROVIDING ANY GUARANTEE OR WARRANTY FOR THE ACCURACY OF THE INFORMATION PROVIDED HEREIN. I AM NOT PROVIDING ANY GUARANTEE OR WARRANTY FOR THE ACCURACY OF THE INFORMATION PROVIDED HEREIN. I AM NOT PROVIDING ANY GUARANTEE OR WARRANTY FOR THE ACCURACY OF THE INFORMATION PROVIDED HEREIN.

JASON WIESBROCK, P.E.
ILLINOIS REGISTRATION NO. 062-051654
EXPIRATION DATE: 11-30-21

Jason Wiesbrock
REGISTERED PROFESSIONAL ENGINEER

SEA:



OWNER

JOE DIETER AND SONS
30 W OIO FERRY ROAD
NAPERVILLE, IL 60563
PHONE: 630-768-1874
CONTACT: ANDY DIETER

GENERAL CONTRACTOR

FEC
P.O. BOX 340
MINOOKA, IL 60447
PHONE: 815-467-4020
CONTACT: BILL SLAVIK

INDEX

SHEET NO.	SHEET DESCRIPTION
1	COVER SHEET
2	TYPICAL SECTIONS & GENERAL NOTES
3	EXISTING TOPOGRAPHY PLAN
4	DEMO DESTRUCTION PLAN
5	GEOMETRIC PLANS
6	GRADING PLANS
7	UTILITY PLANS
P-10	SE-1/SEI SOIL EROSION & SEDIMENT CONTROL PLANS
11	SPECIFICATIONS
12-14	D1-100 DETAILS

CALL JULIE 1-800-492-0123
WITH THE FOLLOWING:
COUNTY: MINOOKA, ILLINOIS
CITY: TOWNSHIP MINOOKA, T34N, R9E
SEC. 8 & 1/2, SEC. NO. 2 SE 1/4
48 HOURS BEFORE YOU DIG.
EXCLUDING SAT., SUN & HOLIDAYS

LOCATION MAP

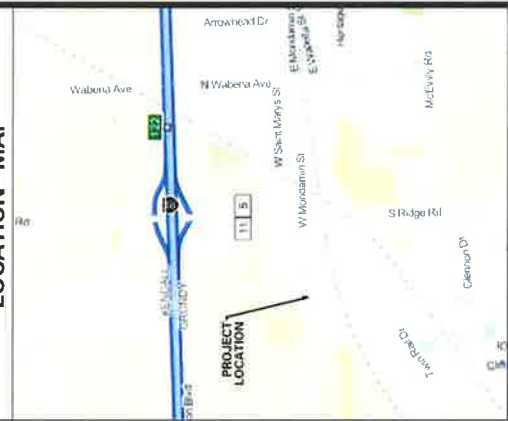

NOTES:
SPACECO INCL IS TO BE NOTICED AT LEAST THREE (3) DAYS PRIOR TO STARTING CONSTRUCTION AND SHALL BE INCLUDED IN THE RECONSTRUCTION MEETINGS
PROPERTY DESCRIPTION:
LOT 2 IN 84 LUMBER SUBDIVISION BEING A SUBDIVISION OF PART OF THE SOUTHEAST QUARTER OF SECTION 2, TOWNSHIP 34 NORTH RANGE & EAST OF THE THIRD PRINCIPAL MERIDIAN, ACCORDING TO THE PLAT OF SUBDIVISION DATED JANUARY 26, 2009 AS DOCUMENT #26866, IN GRUNDY COUNTY, IL.
SOURCE BENCHMARK:
TOPCON, TOPNET LIVE NETWORK
POINT MARK (444)
JOLIET, ILLINOIS
ELLIPSOID HEIGHT = 156.3 M
ORTH. HEIGHT = 461.607 (NAVD83)
SITE BENCHMARK:
CUT CROSS ON NORTH BONNET BOLT ON FIRE HYDRANT LOCATED ON CORNER OF MINDOMA RD ON EAST SIDE OF SCHOOL BUS STOP AT ENTRANCE.
ELEVATION = 580.12 (NAVD 83)



THIS SIGN IS TO BE USED TO INDICATE THAT THE SPACE IS TO BE MADE ACCESSIBLE TO PEOPLE WITH PHYSICAL HANDICAPS.
THE SIGN SHALL BE PLACED IN THE LOCATION SHOWN ON THE DRAWING.
FOR MORE INFORMATION, CONTACT THE ILLINOIS DEPARTMENT OF COMMUNITY DEVELOPMENT, 100 SOUTH WASHINGTON STREET, SPRINGFIELD, ILLINOIS 62762.
LAND ENGINEER: JASON WIESBROCK, P.E.

REVISIONS

ORIGINAL PLAN DATE: JULY 22, 2020

#	SHEET #	REMARKS	DATE
1	ALL	PER VILLAGE / OWNER	09/28/20
2	ALL	PER VILLAGE	10/20/20
3	5-7	PER VILLAGE & MEP COORDINATE	01/04/21

Jason Wiesbrock
ENGINEER
JASON E. WIESBROCK, P.E.
ILLINOIS REGISTRATION NO. 062-051654
EXPIRATION DATE: 11-30-21
PROFESSIONAL SEAL NO. 18-01157
EXPIRATION DATE: 04/30/23

LOT 2 - 84 LUMBER
SUBDIVISION
MINOOKA, IL

224 1/2 N. Liberty St. Morris, Illinois 60450
Phone: (815) 941-0260 Fax: (815) 941-0263

CONSULTING ENGINEERS
SITE DEVELOPMENT ENGINEERS
LAND SURVEYORS



SPACECO INC.
1524 S. 21ST ST.
MORRIS, ILLINOIS 60450
DATE: 07/22/2020
JOB NO: 22722220
ISSUE: 1

1 OF 4
SHEET

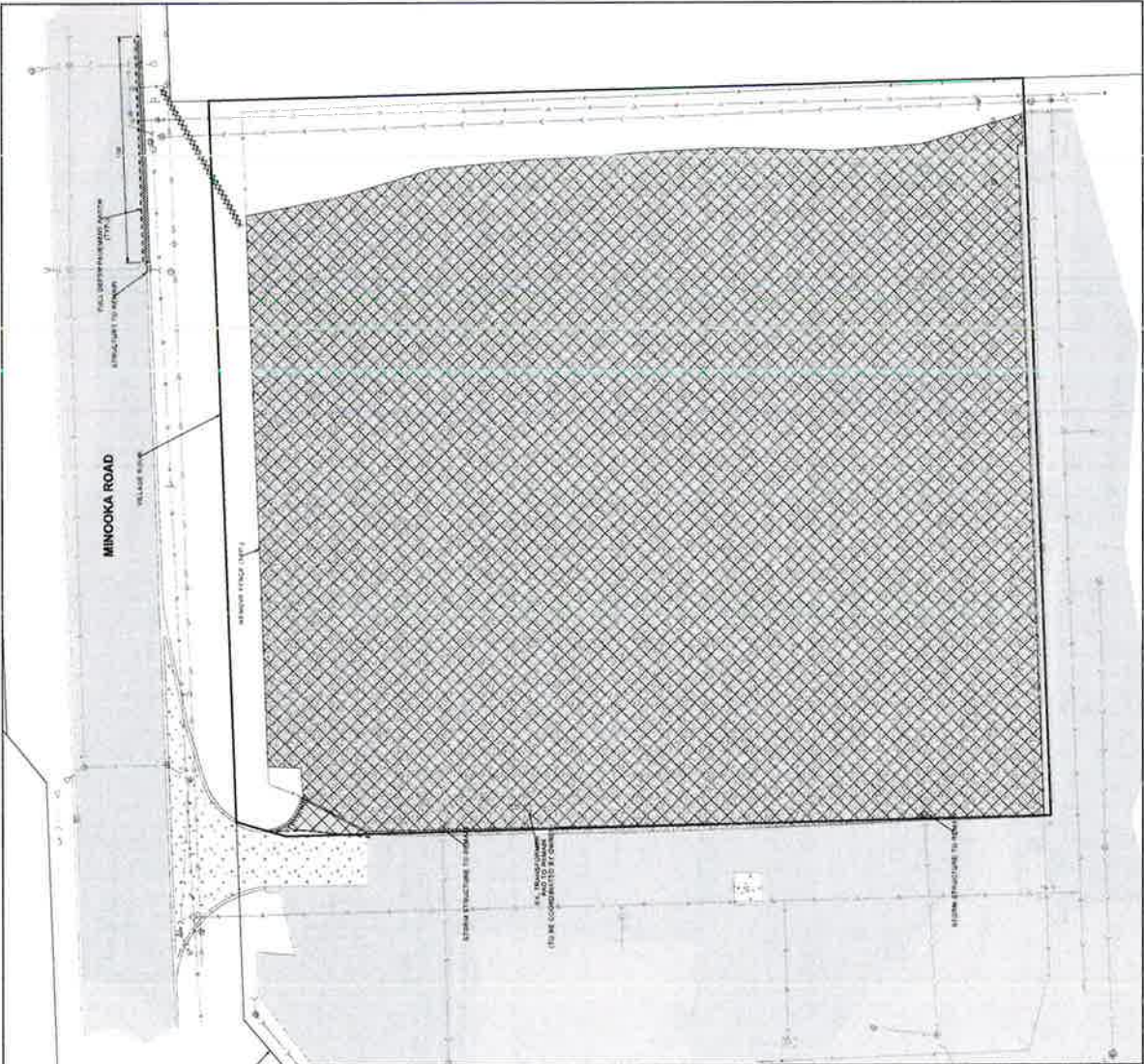

- NOTES:**
1. ALL UTILITIES SHOWN TO BE REMOVED SHALL BE FULLY DISCONNECTED.
 2. FINAL DISCONNECT OF THE EXISTING UTILITY SERVICES AND UTILITIES SHALL BE COMPLETED BY THE CONTRACTOR WITHIN THE PROJECT PERMITS AND IN ACCORDANCE WITH THE ILLINOIS DEPARTMENT OF TRANSPORTATION AND STATE POLICE STANDARDS FOR THE PROJECT.
 3. THE DEMOLITION CONTRACTOR SHALL BE AWARE THAT THESE UTILITIES ARE SHOWN ON THE EXISTING UTILITY DRAWINGS. EXISTING UTILITY PIPES TO BE REMOVED AND UTILITY LINES TO BE DISCONNECTED BY OWNER.

- LEGEND:**
- ASPHALT SURFACE (FULL DEPTH)
 - ||||| CURB AND CUTTER TO BE REMOVED
 - XXXXXXXXXX UNDERGROUND UTILITY
 - ||||| SIDEWALK REMOVAL
 - XXXXXX FULL DEPTH PAVEMENT REMOVAL



NO.	DATE	REVISIONS

NO.	DATE	REVISIONS
1	05.23.21	PER VILLAGE ENGINEER
2	10.20.20	PER VILLAGE ENGINEER
3	01.09.21	PER VILLAGE & REVISIONS
4	03.23.21	PER VILLAGE ENGINEER

DEMOLITION PLAN
LOT 2-84 LUMBER SUBDIVISION
MINOOKA, ILLINOIS

CONSULTING ENGINEERS
SITE DEVELOPMENT ENGINEERS
LAND SURVEYORS
 2200 N. LAMAR BLVD.
 SUITE 100
 MINOOKA, ILLINOIS 62450
 PHONE: 815.233.1111 FAX: 815.233.1112

SPACECO INC.
ILLINOIS
MINOOKA
PERMITS
ENGINEER
NO. 001-00000000
ISSUED
DATE
BY
SCALE
1\"/>

DEMO
 11.01.21

NO.	DATE	REVISIONS
1	03/27/18	PER VILLAGE
2	03/27/18	PER VILLAGE & PER COORDINATE
3	03/27/18	PER VILLAGE
4	03/27/18	REVISIONS

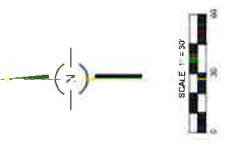

- LEGEND**
- FINISHED FLOOR
 - LOCAL DRAINAGE
 - 100-PSI OVERBOND FLOW ROUTE
 - LOCAL DRAINAGE DITCH
 - TOP OF CURB
 - EDGE OF PAVEMENT
 - 1. EXISTING MATCH EXISTING CONCRETS

- NOTES**
1. ADD 500 TO ELEVATIONS SHOWN AS MOUL.
 2. ALL CURB TO BE MANHOLE COVER.
 3. ALL DRAINAGE TO BE TO THE STREET UNLESS OTHERWISE NOTED.
 4. ALL DISTURBED AREAS TO BE RESEED WITH 5" TOPSOIL AND SEED.
 5. ALL PROPOSED AREAS TO MAINTAIN POSITIVE SITE DRAINAGE DURING CONSTRUCTION.
 6. ALL PROPOSED GRASSES SHALL MATCH THE EXISTING GRASSES.
 7. PERFORATOR AND SEWERAGE CENTER, MEASURES SHALL BE IN PLACE PRIOR TO START AT THE PROPERTY LINE.
 8. ALL EXISTING WALLS SHALL BE RECONSTRUCTED TO 4" TOPSOIL FOR PAVEMENT DURING PHASE 2.
 9. SOUTH PARKING AREA TO BE 4" TOPSOIL FOR PAVEMENT DURING PHASE 2.

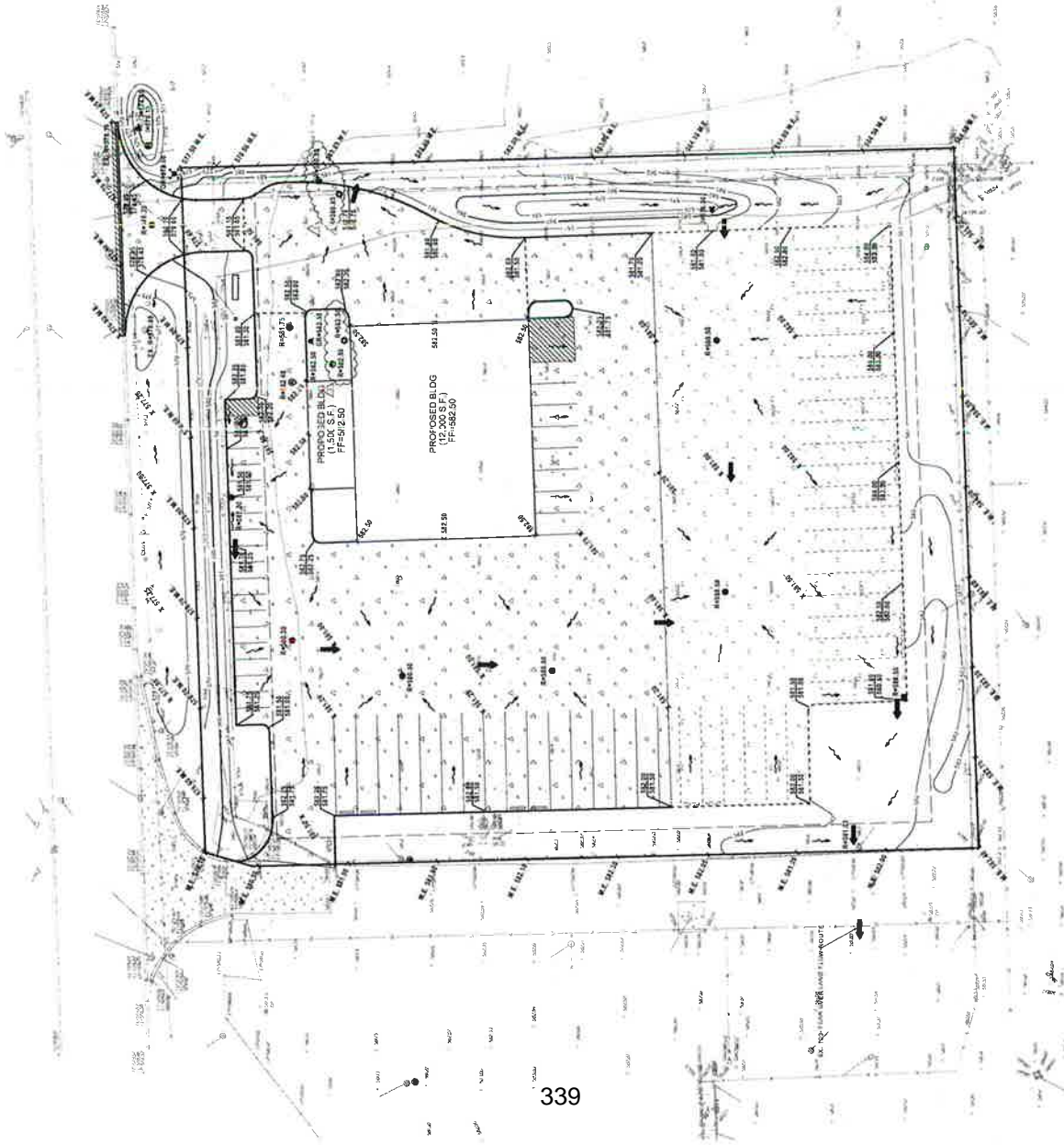

LOT 2 - 84 LUMBER SUBDIVISION
MENOKA, ILLINOIS

<p>STABILIZED CONCRETE ENTRANCE PLAN</p>	<p>STABILIZED CONCRETE ENTRANCE PLAN</p>	<p>STABILIZED CONCRETE ENTRANCE PLAN</p>	<p>STABILIZED CONCRETE ENTRANCE PLAN</p>	<p>STABILIZED CONCRETE ENTRANCE PLAN</p>	<p>STABILIZED CONCRETE ENTRANCE PLAN</p>	<p>STABILIZED CONCRETE ENTRANCE PLAN</p>
<p>STABILIZED CONCRETE ENTRANCE PLAN</p>	<p>STABILIZED CONCRETE ENTRANCE PLAN</p>	<p>STABILIZED CONCRETE ENTRANCE PLAN</p>	<p>STABILIZED CONCRETE ENTRANCE PLAN</p>	<p>STABILIZED CONCRETE ENTRANCE PLAN</p>	<p>STABILIZED CONCRETE ENTRANCE PLAN</p>	<p>STABILIZED CONCRETE ENTRANCE PLAN</p>
<p>STABILIZED CONCRETE ENTRANCE PLAN</p>	<p>STABILIZED CONCRETE ENTRANCE PLAN</p>	<p>STABILIZED CONCRETE ENTRANCE PLAN</p>	<p>STABILIZED CONCRETE ENTRANCE PLAN</p>	<p>STABILIZED CONCRETE ENTRANCE PLAN</p>	<p>STABILIZED CONCRETE ENTRANCE PLAN</p>	<p>STABILIZED CONCRETE ENTRANCE PLAN</p>
<p>STABILIZED CONCRETE ENTRANCE PLAN</p>	<p>STABILIZED CONCRETE ENTRANCE PLAN</p>	<p>STABILIZED CONCRETE ENTRANCE PLAN</p>	<p>STABILIZED CONCRETE ENTRANCE PLAN</p>	<p>STABILIZED CONCRETE ENTRANCE PLAN</p>	<p>STABILIZED CONCRETE ENTRANCE PLAN</p>	<p>STABILIZED CONCRETE ENTRANCE PLAN</p>
<p>STABILIZED CONCRETE ENTRANCE PLAN</p>	<p>STABILIZED CONCRETE ENTRANCE PLAN</p>	<p>STABILIZED CONCRETE ENTRANCE PLAN</p>	<p>STABILIZED CONCRETE ENTRANCE PLAN</p>	<p>STABILIZED CONCRETE ENTRANCE PLAN</p>	<p>STABILIZED CONCRETE ENTRANCE PLAN</p>	<p>STABILIZED CONCRETE ENTRANCE PLAN</p>
<p>STABILIZED CONCRETE ENTRANCE PLAN</p>	<p>STABILIZED CONCRETE ENTRANCE PLAN</p>	<p>STABILIZED CONCRETE ENTRANCE PLAN</p>	<p>STABILIZED CONCRETE ENTRANCE PLAN</p>	<p>STABILIZED CONCRETE ENTRANCE PLAN</p>	<p>STABILIZED CONCRETE ENTRANCE PLAN</p>	<p>STABILIZED CONCRETE ENTRANCE PLAN</p>
<p>STABILIZED CONCRETE ENTRANCE PLAN</p>	<p>STABILIZED CONCRETE ENTRANCE PLAN</p>	<p>STABILIZED CONCRETE ENTRANCE PLAN</p>	<p>STABILIZED CONCRETE ENTRANCE PLAN</p>	<p>STABILIZED CONCRETE ENTRANCE PLAN</p>	<p>STABILIZED CONCRETE ENTRANCE PLAN</p>	<p>STABILIZED CONCRETE ENTRANCE PLAN</p>

NO.	DATE	REVISIONS
1	03/27/21	PER VILLAGE
2	03/27/21	PER VILLAGE & MEP CONSULTANT
3	03/27/21	PER VILLAGE
4	03/27/21	PER VILLAGE OWNER

NO.	DATE	REVISIONS
1	03/27/21	PER VILLAGE
2	03/27/21	PER VILLAGE & MEP CONSULTANT
3	03/27/21	PER VILLAGE
4	03/27/21	PER VILLAGE OWNER

LOT 2 - 84 LUMBER SUBDIVISION
MINOOKA, ILLINOIS

SOIL EROSION & SEDIMENT CONTROL PLAN-3

CONSULTING ENGINEERS
LAND SURVEYORS
LAND DEVELOPMENT ENGINEERS

2224 N. LAMAR STREET
MERRILLVILLE, IN 46402
TEL: 317.541.0000 FAX: 317.541.0025

SPRAGCO INC.
FILE NAME: 12242-SE3
SHEET: 11/27/20
NO. AND DATE: 12242
PROJECT: SE3

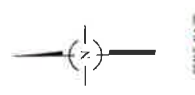

SYMBOL LEGEND

	STABILITY CONSTRUCTION
	SILT FENCE
	CATCH-ALL BASIN
	PAVING
	PERMANENT SEEDING
	CONCRETE WASHOUT
	UNSEEDED AREA
	EROSION CONTROL BLANKET
	MUD TRAP (AS NEEDED)

EROSION CONTROL NOTES:

1. ALL EROSION AND SEDIMENT CONTROL MEASURES SHALL BE IN PLACE PRIOR TO ANY CONSTRUCTION ACTIVITIES.
2. THE CONTRACTOR SHALL MAINTAIN PROPER SITE DRAINAGE DURING CONSTRUCTION.
3. THE CONTRACTOR IS RESPONSIBLE FOR DIST CONTROL.
4. DIST CONTROL MEASURES SHALL BE MAINTAINED THROUGHOUT CONSTRUCTION.
5. ADDITIONAL EROSION CONTROL MEASURES SHALL BE IMPLEMENTED IF A SWEEP INSPECTION OF THE SITE INDICATES A DEFICIENCY.
6. ALL TEMPORARY AND PERMANENT EROSION AND SEDIMENT CONTROL MEASURES SHALL BE MAINTAINED AND REPAIRED AS NECESSARY TO PREVENT A VIOLATION.
7. MAJOR ADJUSTMENTS TO THE SITE DEVELOPMENT AND EROSION CONTROL PLAN SHALL BE APPROVED BY THE SAME PARTIES AS THE ORIGINAL PLAN.
8. THE CONTRACTOR SHALL BE RESPONSIBLE FOR THE PROTECTION OF ALL EXISTING UTILITIES AND STRUCTURES.
9. THE CONTRACTOR SHALL BE RESPONSIBLE FOR THE PROTECTION OF ALL EXISTING UTILITIES AND STRUCTURES.
10. THE CONTRACTOR SHALL BE RESPONSIBLE FOR THE PROTECTION OF ALL EXISTING UTILITIES AND STRUCTURES.
11. THE CONTRACTOR SHALL BE RESPONSIBLE FOR THE PROTECTION OF ALL EXISTING UTILITIES AND STRUCTURES.
12. THE CONTRACTOR SHALL BE RESPONSIBLE FOR THE PROTECTION OF ALL EXISTING UTILITIES AND STRUCTURES.
13. THE CONTRACTOR SHALL BE RESPONSIBLE FOR THE PROTECTION OF ALL EXISTING UTILITIES AND STRUCTURES.
14. THE CONTRACTOR SHALL BE RESPONSIBLE FOR THE PROTECTION OF ALL EXISTING UTILITIES AND STRUCTURES.
15. THE CONTRACTOR SHALL BE RESPONSIBLE FOR THE PROTECTION OF ALL EXISTING UTILITIES AND STRUCTURES.
16. THE CONTRACTOR SHALL BE RESPONSIBLE FOR THE PROTECTION OF ALL EXISTING UTILITIES AND STRUCTURES.
17. THE CONTRACTOR SHALL BE RESPONSIBLE FOR THE PROTECTION OF ALL EXISTING UTILITIES AND STRUCTURES.
18. THE CONTRACTOR SHALL BE RESPONSIBLE FOR THE PROTECTION OF ALL EXISTING UTILITIES AND STRUCTURES.
19. THE CONTRACTOR SHALL BE RESPONSIBLE FOR THE PROTECTION OF ALL EXISTING UTILITIES AND STRUCTURES.
20. THE CONTRACTOR SHALL BE RESPONSIBLE FOR THE PROTECTION OF ALL EXISTING UTILITIES AND STRUCTURES.

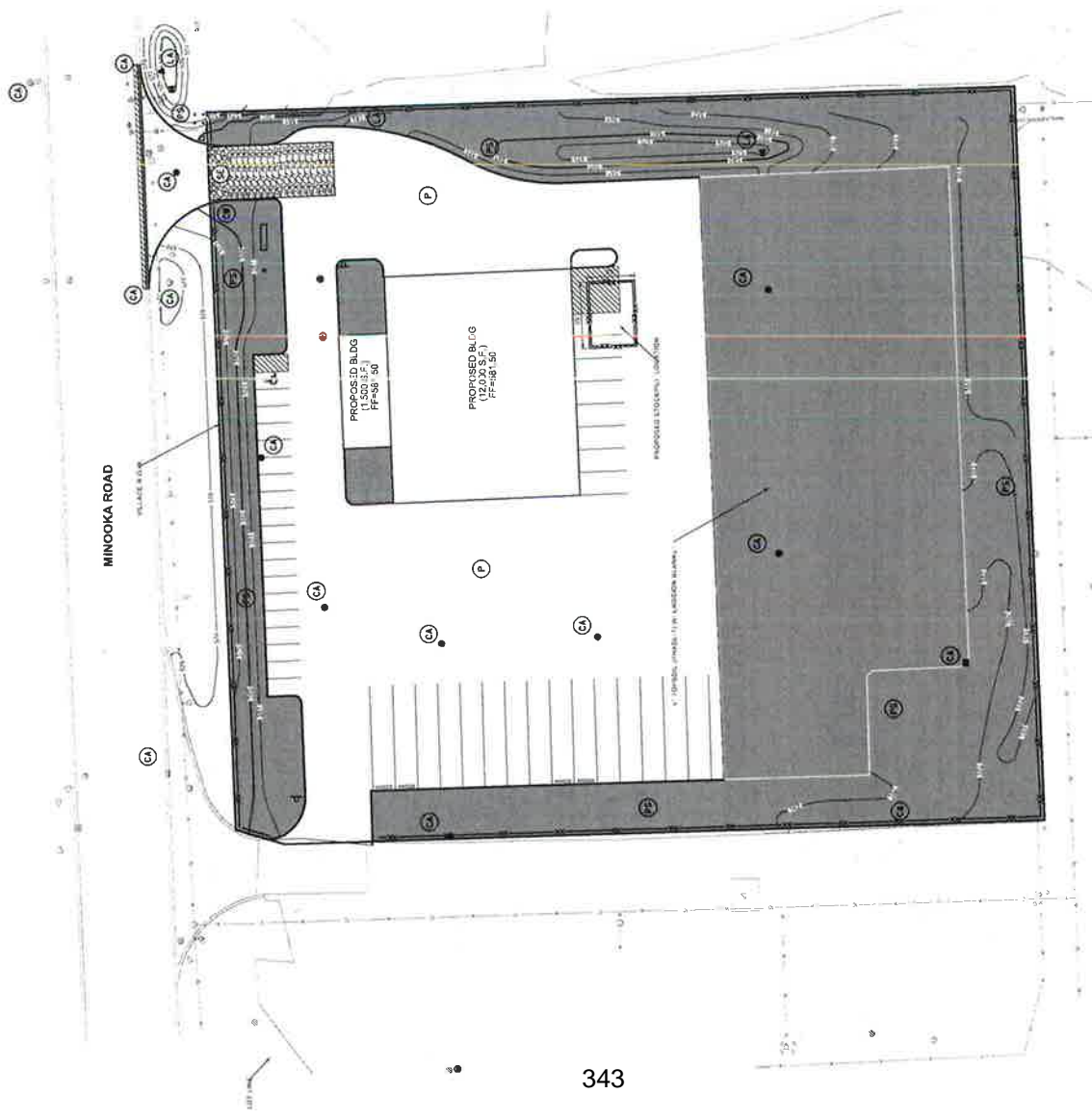

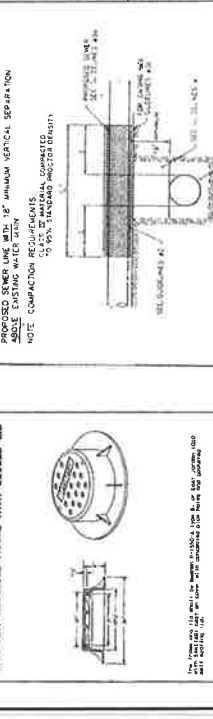
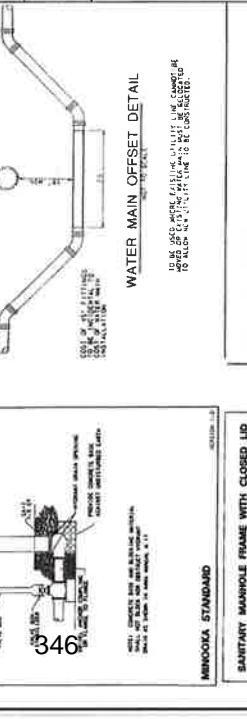
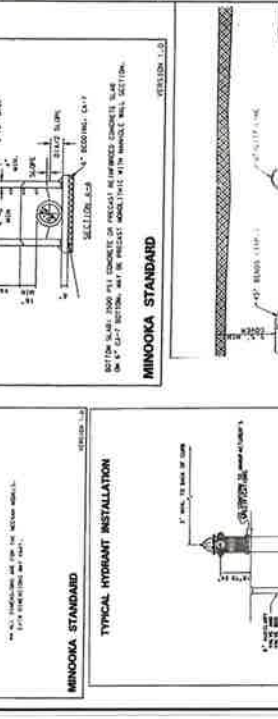
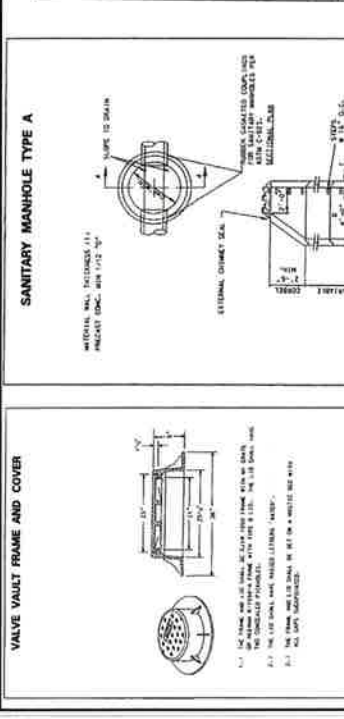
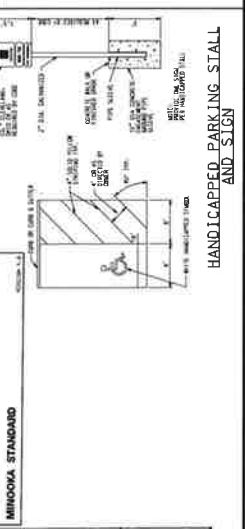
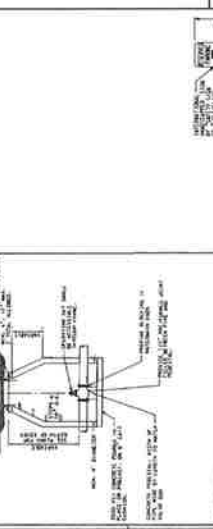
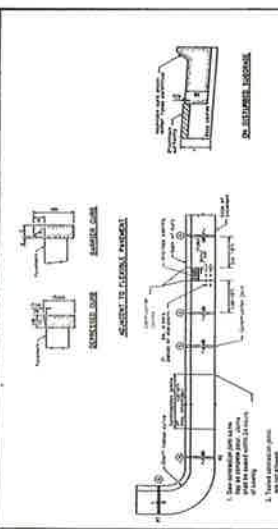
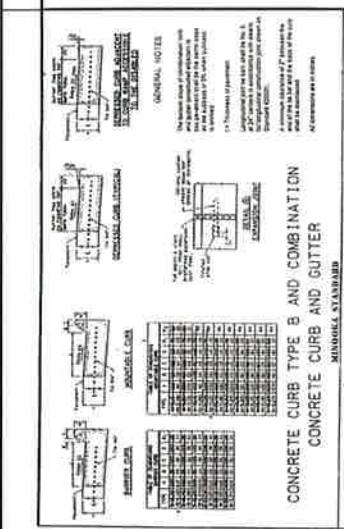
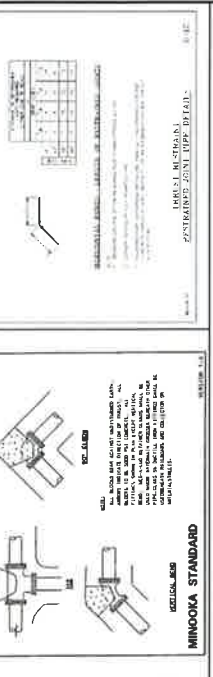
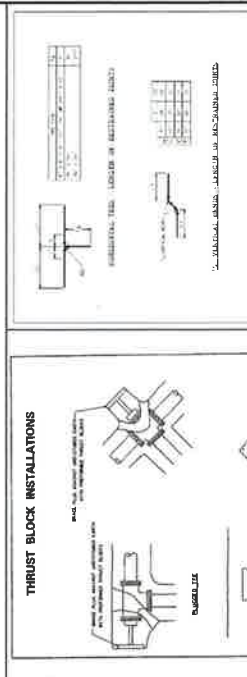
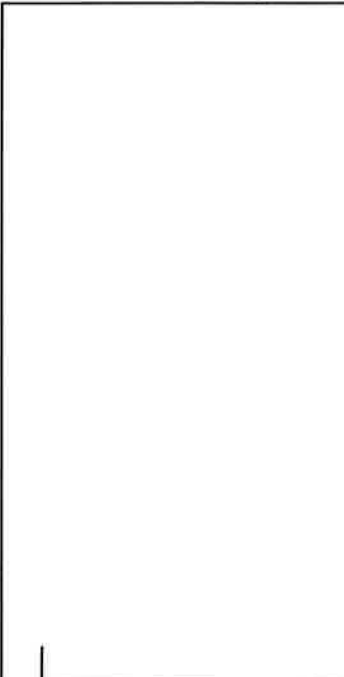

NO.	DATE	REVISIONS
1	09-27-93	PER VILLAGE OWNER
2	10-27-93	PER VILLAGE
3	07-04-94	PER VILLAGE & REP COORDINATE
4	09-27-93	PER VILLAGE

NO.	DATE	REVISIONS
1	09-27-93	PER VILLAGE OWNER
2	10-27-93	PER VILLAGE
3	07-04-94	PER VILLAGE & REP COORDINATE
4	09-27-93	PER VILLAGE

DETAILS - 3
 LOT 2 - 84 LUMBER SUBDIVISION
 MINOOKA, ILLINOIS

CONSULTING ENGINEERS
 SITE DEVELOPMENT ENGINEERS
 LAND SURVEYORS
 204 S. KENNEDY STREET
 DEERFIELD, ILLINOIS 60015
 PHONE: (708) 431-1100

SARGENT & GORDY INC.
 FILE NUMBER: 10042-0013
 DATE: 07/27/93
 JOB NO: 10347
 SHEET
DET3
 14 OF 14

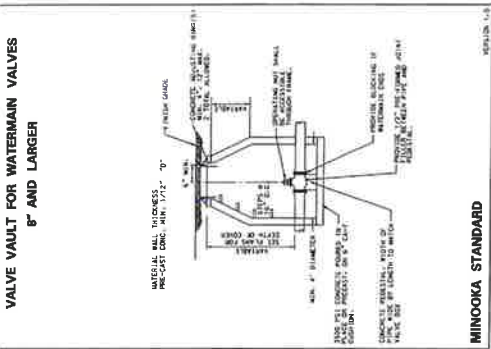
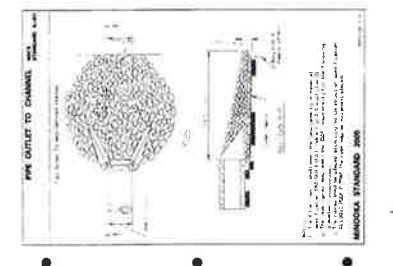
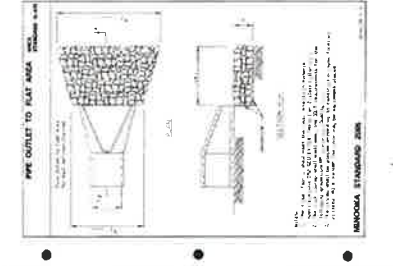
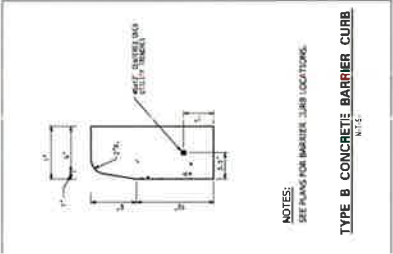
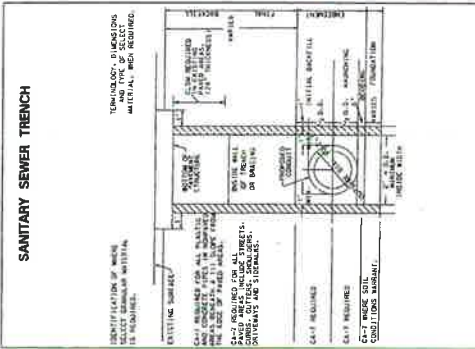
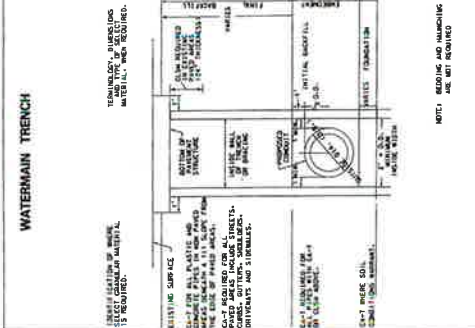
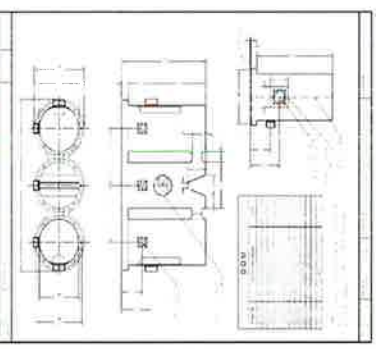
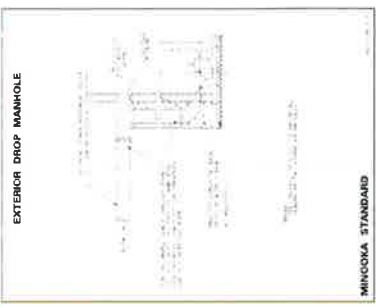



MINOOKA

COMMUNITY HIGH SCHOOL

District #111 mchs.net

*Mission: Strengthen **M**astery, **C**ollaboration, **H**igh Expectations, and **S**uccess for All Students.*

John Troy
Assistant Superintendent & General Counsel

Date: April 29, 2021

To: Board of Education
Dr. Kenny Lee

RE: Transportation Drainage Bid

Districts 111 and 201 (joint owners of the transportation bus barn) are required by the Village to install drainage across the transportation bus barn parking lot. When the Districts purchased the old 84 Lumber property and improved it for use as a transportation bus barn the overland drainage easement was impacted. With the development of the property next door the Village has requested the Districts to reestablish the drainage. Due to the need to maintain the parking lot for bus transit an overland drainage solution was not practical and an underground pipe design was recommended. This solution was put out to bid and we received four responses:

Winner - \$88,901
Pullara - \$94,160 plus add-ons of \$4,320 for Saturday work.
Austin Tyler - \$117,000
Stott - \$169,900

The administration is recommending that the transportation drainage bid be awarded to the low bidder Winner Excavating in the amount of \$88,901. District 201 has already approved the award to Winner at their April 19 Board meeting.