



LINCOLNWOOD SCHOOL
DISTRICT 74
BOARD OF EDUCATION
Regular Meeting AGENDA
Thursday, June 1, 2023 at **7:30**
PM

BOARD OF EDUCATION
Kevin Daly, *President*
Rupal Shah Mandal, *Vice President*
John P. Vranas, *Secretary*
Maxie Boynton
Myra A. Foutris
Jay Oleniczak
Peter D. Theodore

ADMINISTRATION
Dr. David L. Russo, *Superintendent of Schools*
Dr. Dominick M. Lupo, *Assistant Superintendent for
Curriculum and Instruction*
Courtney Whited, *Business Manager/CSBO*

*Agenda of the Regular Meeting of the Board of Education of Lincolnwood School District 74,
Cook County, Illinois, to be held in the Lincolnwood Village Hall - Gerald C. Turry Village Board Room
6900 North Lincoln Avenue
Lincolnwood, Illinois 60712,
on Thursday, June 1, 2023.*

Bill Reviewers for the Month: Peter Theodore and John P. Vranas

1. CALL TO ORDER/ROLL CALL/PLEDGE OF ALLEGIANCE - (7:30 p.m.)

- Kevin Daly
- Maxie Boynton
- Myra A. Foutris
- Jay Oleniczak
- Rupal Shah Mandal
- Peter D. Theodore
- John P. Vranas

ADMINISTRATIVE TEAM MEMBERS

- | | |
|---|---|
| <input type="checkbox"/> Dr. David L. Russo | <input type="checkbox"/> Dr. Dominick M. Lupo |
| <input type="checkbox"/> Courtney Whited | <input type="checkbox"/> Mark Atkinson |
| <input type="checkbox"/> Aliaa Ibrahim | <input type="checkbox"/> Joseph Segreti |
| <input type="checkbox"/> Jennifer Ruttkay | <input type="checkbox"/> Chris Harmon |
| <input type="checkbox"/> Jordan Stephen | |
| <input type="checkbox"/> Renee Tolnai | |

2. SEATING OF BOARD MEMBER/OATH OF OFFICE: Kevin Daly, School Board President

New Board Member Maxie Boynton will be officially seated and take her Oath of Office at the scheduled June 1, 2023 Board of Education meeting.

- a. Oath of Office for Newly-Elected Lincolnwood School District 74 Board of Education Member Maxie Boynton (See Policy 2:80) 7
President Daly: Leads the newly-elected Board of Education member in the Oath of Office.
- b. Seating of New Board Member - Maxie Boynton (Two-Year Term)
President Daly Welcomes New-Elected Board Member Maxie Boynton

3. DISTRICT RECOGNITION

- a. Honoring Lincolnwood School District 74 Retiree Angelika Schmidt, Food Service Coordinator
- b. Village of Lincolnwood - 2023 Vehicle Sticker Artwork Winner - Lincoln Hall 7th Grader Gio B.
- c. Lincoln Hall Varsity Boys Volleyball Champions
- d. Lincoln Hall Varsity Girls Soccer Champions¹

- e. Lincoln Hall Junior Varsity Girls Soccer Champions
- f. 2023 National Spanish Examinations - National Recognition for Excellent Performance - Lincoln Hall Students - Gian F.P., Lexi C. and Jonathan B.

4. AUDIENCE TO VISITORS

5. INFORMATION/ACTION: CONSENT AGENDA

(Any member of the Board wishing to vote separately on a Consent Agenda item should request removal of that item from the Consent Agenda.)

a. APPROVAL OF MINUTES

- I. Regular Board Meeting Minutes - **MAY 4, 2023** 9

b. EMPLOYMENT MATTERS

- I. Personnel Report
- II. Retirement
 - 1. **Angie Schmidt**, Food Service Coordinator, Lincoln Hall, effective June 30, 2023
- III. Resignation
 - 1. **Bosung Park**, School Nurse, Rutledge Hall, effective June 8, 2023
 - 2. **Amanda Ibraham**, Paraprofessional, Rutledge Hall, effective June 8, 2023
- IV. FMLA Request
 - 1. **Joe Segreti**, Assistant Principal, Lincoln Hall, effective April 24, 2023, with an expected return of May 5, 2023

c. Policy

- I. 2nd Reading/Adoption of Policy
 - 1. Press Plus Issue #111 March 2023
 - (1) Draft Updates
 - (1) 4:60 Purchases 19
 - (2) 5:30 Hiring Process and Criteria 23
 - (3) 5:90 Abused and Neglected Child Reporting 28
 - (4) 5:150 Personnel Records 33
 - (5) 6:135 Accelerated Placement Program 36
 - (6) 6:230 Library Media Program 39
 - (7) 6:260 Complaints About Curriculum, Instructional Materials, and Programs 43

- d. Transportation Contract 2023-24 with First Student, Inc 45
 The Finance Committee concurs with the Administration to recommend to the Board of Education to accept this Amendment from First Student, Inc. for transportation services with a 3.75% rate increase on current rates effective August 1, 2023 through July 31, 2024.

- e. FY24 & FY25 Audit Services 94
 The Finance Committee concurs with the Administration to recommend to the Board of Education to retain the firm of Lauterbach & Amen, LLP over the course of three fiscal years spanning 2023-2025 for audit and single audit services not to exceed \$83,400.

- f. GASB 74/75 Actuarial Valuation Services from Lauterbach & Amen, LLP 103
 The Finance Committee concurs with the Administration to recommend to the Board of Education to approve the contract with Lauterbach & Amen, LLP for actuarial services associated with determining the value of GASB 74/75 Other Post-Employment Benefits (OPEB) for the year ending June 30, 2024 for \$3,890 and the year ending June 30, 2025 for \$1,020.

- g. FY24 Facility Rental Fee Waiver Request from LBSA 109
 The Finance Committee concurs with the Administration to recommend to the Board of Education to

waive facility rental fees during fiscal year 2024 for Lincolnwood Baseball and Softball Association.

- h. BrainPop/BrainPop Jr. Renewal Contract for 2023-2024 School Year 111
The Finance Committee concurs with the Administration to recommend to the Board of Education to renew the BrainPop and BrainPop Jr. subscription for all students in all grades in the District in the amount of \$8,749.65 from August 12, 2023 to August 11, 2024.
- i. 2023-2024 Encyclopedia Britannica Renewal 142
The Finance Committee concurs with the Administration to recommend to the Board of Education to approve the Britannica School Subscription Contract in the amount of \$715 from July 1, 2023 to June 30, 2024.
- j. Interactive Display Refresh 160
The Finance Committee concurs with the Administration to recommend to the Board of Education to approve the purchase of 25 classroom displays in the amount not to exceed \$61,000 for the 2023-2024 school year.
- k. 2023-2024 Learning A-Z Product Renewal 168
The Finance Committee concurs with the Administration to recommend to the Board of Education to approve the renewal of the Learning A-Z software in the amount of \$8,992.50 from August 7, 2023 to August 7, 2024.
- l. 2023-2028 Finalsite Inc. Website and Hosting Services Contract 192
The Finance Committee concurs with the Administration to recommend to the Board of Education to approve the Finalsite Contract for design services, setup fees, website hosting for the proposed 5-year quote in the amount of: \$2,229 for school year 2023-24, \$2,429 for school year 2024-25, \$2,629 for school year 2025-26, \$2,829 for school year 2026-27 and \$3,029 for school year 2027-28.
- m. 2023-2024 School Year PebbleGo Renewal 246
The Finance Committee concurs with the Administration to recommend to the Board of Education to approve the PebbleGo Contract in the amount of \$1,197 for the 2023-2024 school year.
- n. Annual Renewal of Formative at Rutledge Hall for 2023-2024 256
The Finance Committee concurs with the Administration to recommend to the Board of Education to renew the Formative license at Rutledge Hall for the amount of \$3,515.89 for services between July 1, 2023 and June 30, 2024.
- o. Renewal of Seesaw for Schools for Todd Hall for 2023-2024 266
The Finance Committee concurs with the Administration to recommend to the Board of Education to accept the Seesaw license for Seesaw for Schools for the amount of \$3,120 from August 1, 2023 through July 31, 2024.
- p. Renaissance Learning Renewal of FastBridge for 2023-2024 270
The Finance Committee concurs with the Administration to recommend to the Board of Education to approve this Agreement with Renaissance Learning for renewal of FastBridge for the 2023- 2024 school year in the amount of \$7,080.06.
- q. Increase Contingency Amount for Summer 2023 General Work 331
The Administration recommends that the Board of Education approve a contract change order in the amount of \$60,000 for additional contingency allowance funds related to the Summer 2023 General Work project to be performed by Bear Construction Company.
- r. Lincoln Hall's Mechanized Basketball Hoops 333
The Facilities Committee members in attendance stated their support with the Administration to recommend to the Board of Education to accept the proposals from H2I and Bear Construction for materials & services related to improving Lincoln Hall's Basketball Hoops in the amount of \$77,062.92

for a summer 2023 installation.

- s. Tractor Purchase and Trade-In 341
The Facilities Committee members in attendance stated their support with the Administration to recommend to the Board of Education to accept this Sales Quote from Russo Power Equipment for a new Kubota tractor with attachments in the amount of \$34,194.20 along with a trade in of the District's John Deere tractor and attachments.
- t. Window Treatments for Rutledge Hall's First Floor 345
The Facilities Committee members in attendance stated their support with the Administration to recommend to the Board of Education to accept the quote from Indecor for window roller shade installations throughout the first floor of Rutledge Hall in the amount of \$22,350 during Summer 2023.

Rationale: As part of the regular meeting, the Board of Education routinely approves minutes, personnel items, Board policies, and routine business matters.

Recommended Motion: I move that the Lincolnwood School District 74 Board of Education approves those items on the Consent Agenda as appear above.

Motion by member: _____ Seconded by: _____

6. UNFINISHED BUSINESS

7. NEW BUSINESS

8. COMMUNICATION FROM BOARD MEMBERS

- a. NTDSE/District 807: **John P. Vranas/Kevin Daly**
- b. IASB (Illinois Association of School Boards): **Jay Oleniczak/Myra A. Foutris**
- c. Finance Committee: **Peter D. Theodore/Jay Oleniczak**
- d. Facilities Committee: **John P. Vranas/Rupal Shah Mandal**
- e. Policy Committee: **Rupal Shah Mandal/Myra A. Foutris**
- f. President's Report: **Kevin Daly**

I. INFORMATION/DISCUSSION/ACTION: Final Committee Appointments

District 807/NTDSE:

John P. Vranas, Delegate (BOE)
Kevin Daly, Alternate (BOE)

IASB: (Illinois Association of School Boards)

Jay Oleniczak, Delegate (BOE)
Myra A. Foutris, Alternate (BOE)

Finance Committee:

Peter D. Theodore, Chair (BOE)
Jay Oleniczak, Co-Chair (BOE)

Members:

John P. Vranas (BOE)
Michael Bartholomew, Community Member
Maja Kenjar, Community Member
Steven Pawlow, Community Member
Paul Stellatos, Community Member

Facilities Committee:

John P. Vranas, Chair (BOE)
Rupal Shah Mandal, Co-Chair (BOE)⁴

Members:
Myra A. Foutris (BOE)
Wendy Grano, Community Member
Emily McCall, Community Member
Zade Tagani, Community Member

Policy Committee:
Rupal Shah Mandal, Chair (BOE)
Myra A. Foutris, Co-Chair (BOE)

Members:
Maxie Boynton (BOE)
Aaron LaRue
Becky Klinghofer
Melissa Theodore

Rationale: The Board President makes all Board Committee and Liaison Appointments, subject to Lincolnwood School District 74 Board of Education approval.

Recommended Motion: I move that the Lincolnwood School District 74 Board of Education re-approve the revised final Committee appointments without objection.

Motion by member: _____ Seconded by: _____

9. COMMUNICATION TO THE BOARD OF EDUCATION

- a. LTA (Lincolnwood Teacher Association): **Travis DuPriest/Kevin Conley (Co-Presidents)**
- b. LSSU (Lincolnwood Support Staff Union): **Tammer Gad (President)**
- c. PALS (People Active with Lincolnwood Schools): **Mihra Seta (President)**

10. ADMINISTRATIVE REPORTS

- a. Superintendent's Report: **Dr. David L. Russo**
 - I. INFORMATION/DISCUSSION: District Updates
- b. Curriculum and Instruction, Assistant Superintendent's Report: **Dr. Dominick M. Lupo**
 - I. INFORMATION/DISCUSSION: Curriculum Department Update

- c. Business and Operations, Business Manager/CSBO: **Courtney Whited**

I. INFORMATION/DISCUSSION: Finance Report - **MARCH 2023** 347

II. INFORMATION/ACTION: Bills Payable in the Amount of \$1,150,632.32 370

Bills reviewed this month by: Peter Theodore and John P. Vranas

Rationale: The Board of Education routinely reviews and approves invoices and bills.

Recommended Motion: I move that the Lincolnwood School District 74 Board of Education approve invoices and bills in the amount of \$1,150,632.32.

Motion by member: _____ Seconded by: _____

11. AUDIENCE TO VISITORS

12. RECESS INTO CLOSED SESSION

I move that the Lincolnwood School District 74 Board of Education recess into Closed Session for the purposes of: **5 ILCS 120/2(c)(1), amended by P.A. 101-459 - Personnel.**

Motion by member: _____ Seconded by: _____
13. ADJOURNMENT

Motion by member: _____ Seconded by: _____

Dr. David L. Russo, Superintendent of Schools

Lincolnwood School District 74 is subject to the requirements of the Americans with Disabilities Act of 1990. Individuals with disabilities who plan to attend this meeting and who require certain accommodations in order to allow them to observe and/or participate in this meeting, or who have questions regarding the accessibility of this meeting or facility, are requested to contact the District Office at 847-675-8234 promptly to allow Lincolnwood School District 74 to make reasonable accommodations for those persons.

Board of Education

2:80 Board Member Oath and Conduct

Each Board member, before taking his or her seat on the Board, shall take the following oath of office:

I, (name), do solemnly swear (or affirm) that I will faithfully discharge the duties of the office of member of the Board of Education of Lincolnwood School District 74, in accordance with the Constitution of the United States, the Constitution of the State of Illinois, and the laws of the State of Illinois, to the best of my ability.

I further swear (or affirm) that:

I shall respect taxpayer interests by serving as a faithful protector of the School District's assets;

I shall encourage and respect the free expression of opinion by my fellow Board members and others who seek a hearing before the Board, while respecting the privacy of students and employees;

I shall recognize that a Board member has no legal authority as an individual and that decisions can be made only by a majority vote at a public Board meeting; and meeting; and

I shall abide by majority decisions of the Board, while retaining the right to seek changes in such decisions through ethical and constructive channels;

As part of the Board of Education, I shall accept the responsibility for my role in the equitable and quality education of every student in the School District;

I shall foster with the Board extensive participation of the community, formulate goals, define outcomes, and set the course for Lincolnwood School District 74;

I shall assist in establishing a structure and an environment designed to ensure all students have the opportunity to attain their maximum potential through a sound organizational framework;

I shall strive to ensure a continuous assessment of student achievement and all conditions affecting the education of our children, in compliance with State law;

I shall serve as education's key advocate on behalf of students and our community's school (or schools) to advance the vision for Lincolnwood School District 74; and

I shall strive to work together with the District Superintendent to lead the School District toward fulfilling the vision the Board has created, fostering excellence for every student in the areas of academic skills, knowledge, citizenship, and personal development.

The Board President will administer the oath in an open Board meeting; in the absence, of the President, the Vice President will administer the oath. If neither is available, the Board member with the longest service on the Board will administer the oath.

The Board adopts the Illinois Association of School Boards' "Code of Conduct for Members of School Boards." A copy of the Code shall be displayed in the regular Board meeting room. All new Board members agree to abide by the Code of Conduct.

[105 ILCS 5/10-16.5.](#)

CROSS REF.: 1:30 (District Strategic Plan), 2:20 (Powers and Duties of the Board of Education; Indemnification), 2:50 (Board Member Term of Office), 2:100 (Board Member Conflict of Interest), 2:105 (Ethics and Gift Ban), 2:210 (Organizational Board of Education Meeting)

ADOPTED: December 5, 2006

REVISED: January 10, 2019

REVIEWED: January 10, 2019

Lincolnwood School District 74



LINCOLNWOOD SCHOOL DISTRICT
74
BOARD OF EDUCATION
Regular Meeting Minutes
Thursday, May 4, 2023 at **7:30 PM**

BOARD OF EDUCATION
Kevin Daly, *President*
Rupal Shah Mandal, *Vice President*
John P. Vranas, *Secretary*
Myra A. Foutris
Elaina Geraghty
Jay Oleniczak
Peter D. Theodore

ADMINISTRATION
Dr. David L. Russo, *Superintendent of Schools*
Dr. Dominick M. Lupo, *Assistant Superintendent for Curriculum and Instruction*
Courtney Whited, *Business Manager/CSBO*

Minutes of the Regular Meeting of the Board of Education of Lincolnwood School District 74, Cook County, Illinois, was held in the Lincolnwood Village Hall - Gerald C. Turry Village Board Room 6900 North Lincoln Avenue, Lincolnwood, Illinois 60712, on Thursday, May 4, 2023.

1. CALL TO ORDER/ROLL CALL/PLEDGE OF ALLEGIANCE
President Daly called the May 4, 2023 Board of Education meeting to order to 7:35 p.m., roll call was taken and the Pledge of Allegiance was recited.

The Village Hall recording system went off line for the first three minutes of the video/audio recording.

<u>MEMBERS PRESENT</u> Kevin Daly Myra A. Foutris Jay Oleniczak Rupal Shah Mandal Peter D. Theodore John P. Vranas	<u>MEMBERS ABSENT</u> Elaina Geraghty	
--	--	--

<u>ADMINISTRATORS/STAFF PRESENT</u> Dr. David L. Russo Dr. Dominick M. Lupo Chris Harmon	Aliaa Ibrahim Mark Atkinson Jordan Stephen	Jennifer Ruttkay Renee Tolnai
---	--	----------------------------------

2. DISTRICT RECOGNITION
 - a. John Cahill Community Service Scholarship Recipients
 - i. Niles West Seniors: Noah O., Heba M., Porter H., Caitlin A.
Superintendent of Schools Russo presented the above recipients with a District Recognition certificate, and the Board of Education congratulated each \$500 scholarship winner.
 - b. Lincoln Hall Musical Preview: Disney's *The Little Mermaid Jr.*
Co-directors Beth Sterba and Hayley Reynolds, along with student performers for the Spring Musical gave the Board of Education a sneak peek of the upcoming performances on May 19-20, 2023.

c.

Lincolnwood SD74 Student Art Exhibit on display from May 4 - 25, 2023, at the Lincolnwood Village Hall. The District is honored to celebrate and showcase the creativity and dedication to the Visual Arts of Lincoln Hall, Rutledge Hall, and Todd Hall students. This event is free and open to families.

A special reception honoring the students and art teachers took place from 4:30-6:00 p.m. before the Board of Education meeting.

3.

AUDIENCE TO VISITORS

None

4. APPROVAL OF MINUTES

a. Regular Board Meeting Minutes - **APRIL 6, 2023**

b.

Regular Board Meeting - Closed Session Minutes - **APRIL 6, 2023**

It was moved by Secretary Vranas and Vice President Shah Mandal that the Lincolnwood School District 74 Board of Education approve the Regular and Closed Session minutes from the April 6, 2023 Board of Education meeting.

President Daly submitted the motion to a vote and the following vote was recorded:

Ayes: Shah Mandal, Foutris, Oleniczak, Theodore, Vranas, Daly

Nays: None

Absent: Geraghty

Motion passed.

5. RE-ORGANIZATION OF THE BOARD OF EDUCATION

a.

Results of April 4, 2023 Election: Dr. David L. Russo, Superintendent of Schools

Newly-elected Board Member Maxie Boynton will be officially seated and take her Oath of Office at the scheduled June 1, 2023 Board of Education meeting.

Four-Year Term

John P. Vranas

Myra A. Foutris

Jay Oleniczak

Two-Year Term

Maxie Boynton

6. **BOARD WILL ADJOURN SINE DIE FOR THE PURPOSE OF RE-ORGANIZATION**

It was moved by Secretary Vranas and seconded by Vice President Shah Mandal that the Lincolnwood School District 74 Board of Education adjourn into Sine Die for the purpose of Board of Education re-organization.

President Daly submitted the motion to a vote and the following vote was recorded:

Ayes: Shah Mandal, Foutris, Oleniczak, Theodore, Vranas, Daly

Nays: None

Absent: Geraghty

Motion passed.

a. Election of President Pro-Tem and Secretary Pro-Tem: Board Members (See Policies 2:210 and 2:110)

It was moved by Member Vranas and seconded by Member Shah Mandal that Dr. David L. Russo be appointed as President Pro-Tem and Renee Tolnai be appointed Secretary Pro-Tem for the purpose of conducting the election of School Board President.

Member Daly submitted the motion to a voice vote and the motion passed.

7.

CALL TO ORDER: Dr. David L. Russo, Superintendent of Schools

8. RE-ORGANIZATION/OATH OF OFFICE: Dr. David L. Russo, Superintendent of Schools

a. Oath of Office for Continuing Board of Education Members (See Policy 2:80)

President Pro-Tem: Led the Board of Education members in the Oath of Office.

b. Length of the Term for Board Officers (See Policy 2:110)

President Pro-Tem: The next item was to determine the length of the term of office for Board officers. The School Code sets the term of office at two years unless the Board chooses to make it one year.

It was moved by Member Vranas and seconded by Member Shah Mandal that the Lincolnwood School District 74 term of office for Board officers be established for one year.

President Pro-Tem submitted the motion to a voice vote and the motion passed. The term of office for Board officers was established for one year.

c.

Nominations for and Election of Board President (See Policy 2:110)

President Pro-Tem: Nominations were in order for the office of PRESIDENT.

Member Shah Mandal nominated Kevin Daly for PRESIDENT.

Member Theodore seconded.

President Pro-Tem: Member Daly was nominated for PRESIDENT. No further nominations were voiced, nominations were closed.

President Pro-Tem submitted the motion to a voice vote and the nomination passed. The Board elected Kevin Daly to the office of President.

The newly-elected President Daly immediately assumed the chair and conducted the election of other Board officers.

9. RE-ORGANIZATION CONTINUED: Newly-Elected President

a. Nominations For and Election of Board Vice President and Secretary (See Policy 2:210)

President Daly: Called for nominations for the office of VICE PRESIDENT.

Member Vranas nominated Rupal Shah Mandal for office of VICE PRESIDENT.

Member Theodore seconded.

President Daly: Member Shah Mandal was nominated for the office of Vice President. No further nominations were voiced, nominations were closed.

President Daly submitted the motion to a voice vote and the nomination passed. The Board elected Rupal Shah Mandal as Vice President.

The newly-elected Vice President Shah Mandal immediately assumed the chair and conducted the election of other Board officers.

President Daly: Called for nominations for the office of SECRETARY.

Vice President Shah Mandal nominated John P. Vranas for SECRETARY.

Member Oleniczak seconded.

President Daly: Member John P. Vranas was nominated for office of Secretary. No further nominations were voiced, nominations were closed.

President Daly submitted the nomination to a voice vote and the nomination passed. The Board elected John P. Vranas as Secretary.

The newly-elected Secretary Vranas immediately assumed the chair.

10.

CONSENT AGENDA

a. EMPLOYMENT MATTERS

I. Personnel Report

II. New Employment

1.

Michael Giera, General Music Teacher - Long Term Substitute, Lincoln Hall, effective April 17, 2023, \$284.67/per day

III. FMLA Leave

1. **Audrey Evans**, Instructional Technology Coach, Rutledge Hall, effective on or about May 31, 2023 with an expected return of October 12, 2023
2. **Nida Tabba**, Todd Hall, Bilingual Teacher, effective April 25, 2023, with an expected return date of May 9, 2023
3. **Hillary Schroer**, Music Teacher, Rutledge Hall, effective April 17, 2023, with an expected return date of May 30, 2023
4. **Jennifer Savage**, 2nd Grade Teacher, Todd Hall, effective May 11, 2023, with an expected return for the 2023-2024 school year

IV. Unpaid Leave of Absence

1. **Alyssa Burno**, General Music Teacher, Lincoln Hall, effective April 12, 2023

b. Policy

- I. Consent Only - Policies Excluded from 1st Reading for Approval* *These policies are excluded from 1st Reading because they only involve changes in citations or immediate compliance with the law or Illinois School Code.

1. Press Plus Issue #111 March 2023

- (1) Draft Updates
- (1) 8:20 Community Use of School Facilities
- (2) 2:110 Qualifications, Term, and Duties of Board Officers
- (3) 5:125 Personal Technology and Social Media; Usage and Conduct
- (4) 5:260 Student Teachers
- (2) Review and Monitoring
- (1) 4:40 Incurring Debt
- (2) 8:70 Accommodating Individuals with Disabilities
- (3) 5:285 Drug and Alcohol Testing for School Bus and Commercial Vehicle Drivers
- (4) 6:210 Instructional Materials

c. FY24 Consolidated District Plan (formerly known as Approval of Title I District Plan)

The State of Illinois requires the Lincolnwood School District 74 Board of Education to approve the Consolidated District Plan.

d. Upcoming Staff Development Opportunity

- I. **Courtney Whited**, Business Manager/CSBO, IASBO Annual Conference, Peoria, IL, May 3-May 5, 2023

e. Approval of Lincolnwood School District 74 Director Contract

The Lincolnwood School District 74 Board of Education annually approves all Directors' Contracts.

- I. **Jackie McGoey**, Director of Communications and Community Relations

f. E-Rate Category I - AT&T Business Class Internet Access

The Finance Committee concurs to recommend to the Board of Education to accept this Agreement from AT&T for additional internet services to be used for redundancy in the amount of \$120 per month from

July 2023 to July 2024.

g. FirstNet Product Information

The Finance Committee concurs to recommend to the Board of Education to approve the one-time purchase of \$399.96 for equipment to be used with FirstNet.

The Finance Committee concurs to recommend to the Board of Education to pursue a contract in the amount of \$161.96 plus required taxes and fees, for monthly services between May 24, 2023 and May 23, 2024.

h. Renewal of Gaggle.Net, Inc. Contract for the 2023-24 School Year

The Finance Committee concurs to recommend to the Board of Education to renew the Gaggle.Net, Inc. Contract in the amount of \$3,505 for the 2023-2024 school year.

i. Renewal of Jamf Contract for the 2023-24 School Year

The Finance Committee concurs to recommend to the Board of Education to renew the Jamf Quote in the amount of \$13,509 for services between May 24, 2023 and May 23, 2024.

j. 7th Grade STEM Lab Refresh For 2023-2024 School Year

The Finance Committee concurs to recommend to the Board of Education to continue with the replacement of the 7th grade STEM lab computers in an amount not to exceed \$33,000.

It was moved by Secretary Vranas and seconded by Member Theodore that the Lincolnwood School District 74 Board of Education approves those items on the Consent Agenda as appear above.

President Daly submitted the motion to a vote and the following vote was recorded:

Ayes: Shah Mandal, Foutris, Oleniczak, Theodore, Vranas, Daly

Nays: None

Absent: Boynton

Motion passed.

11.

UNFINISHED BUSINESS

None

12.

NEW BUSINESS

None

13. COMMUNICATION FROM BOARD MEMBERS

a. NTDSE/District 807: **John P. Vranas/Kevin Daly**

President Daly attended the April 13, 2023 meeting of the NTDSE Governing Board.

The NTDSE member districts are processing the Articles of Agreement through their Boards for approval.

President Daly was impressed with the Molloy renovation project which is entering its third phase.

The Board presented a staffing proposal for the 2023-24 school year, as well as establishing a partnership with Lurie Children's Hospital for audiology services.

District 219 students interested in Special Education were given an opportunity to work with NTDSE staff in various

disciplines to get first-hand knowledge of the programs available.

b. IASB (Illinois Association of School Boards): **Myra A. Foutris**
No report.

c. Finance Committee: **Peter D. Theodore/Jay Oleniczak**

The Finance Committee last met on April 20, 2023.

The Committee sent five (5) items to the Consent Agenda:

1. E-Rate Category I – AT&T Business Class Internet Access
2. FirstNet Product Information
3. Renewal of Gaggle.Net, Inc. Contract for the 2023-24 School Year
4. Renewal of Jamf Contract for the 2023-24 School Year
5. 7th Grade STEM Lab Refresh For 2023-2024 School Year

As recommended by the Finance Committee, the Resolution Ratifying Changes to Niles Township District for Special Education (NTDSE) Articles of Agreement were presented to the Board for approval.

The next Finance Committee meeting is scheduled for Thursday, May 18, 2023 at 6:30 p.m. The public is welcome.

d. Facilities Committee: **John P. Vranas**

The Facilities Committee last met on March 21, 2023.

The April Facilities Committee meeting was canceled due to a light Agenda.

The next Facilities Committee meeting is scheduled for Tuesday, May 16, 2023 at 6:00 p.m. The public is welcome.

e. Policy Committee: **Rupal Shah Mandal/Myra A. Foutris**

The Policy Committee last met on Friday, April 21, 2023.

The Committee sent (8) policies to the Consent Agenda, and (7) policies to 1st Reading by the Lincolnwood School District 74 Board of Education.

The next Policy Committee meeting is scheduled for Friday, May 19, 2023 at 8:30am in the Administration Building.

The public is welcome.

I. 1st Reading by Lincolnwood School District 74 Board of Education

1. Press Plus Issue #111 March 2023

- (1) Draft Updates
- (1) 4:60 Purchases
- (2) 5:30 Hiring Process and Criteria
- (3) 5:90 Abused and Neglected Child Reporting
- (4) 5:150 Personnel Records
- (5) 6:135 Accelerated Placement Program
- (6) 6:230 Library Media Program
- (7)

6:260 Complaints About Curriculum, Instructional Materials, and Programs

f. President's Report: **Kevin Daly**

I. Final Committee Appointments

District 807/NTDSE:

John P. Vranas, Delegate (BOE)

Kevin Daly, Alternate (BOE)

IASB: (Illinois Association of School Boards)

Jay Oleniczak, Delegate (BOE)

Myra A. Foutris, Alternate (BOE)

Finance Committee:

Peter D. Theodore, Chair (BOE)

Jay Oleniczak, Co-Chair (BOE)

Members:

Michael Bartholomew, Community Member

Maja Kenjar, Community Member

Steven Pawlow, Community Member

Paul Stellatos, Community Member

Facilities Committee:

John P. Vranas, Chair (BOE)

Rupal Shah Mandal, Co-Chair (BOE)

Members:

Myra A. Foutris (BOE)

Wendy Grano, Community Member

Emily McCall, Community Member

Zade Tagani, Community Member

Policy Committee:

Rupal Shah Mandal, Chair (BOE)

Members:

Maxie Boynton (BOE)

Aaron LaRue

Becky Klinghofer

Melissa Theodore

It was moved by Secretary Vranas and seconded by Vice President Shah Mandal that the Lincolnwood School District 74 Board of Education approve the final Committee appointments without objection.

President Daly submitted the motion to a voice vote and the motion passed.

14. COMMUNICATION TO THE BOARD OF EDUCATION

a. LTA (Lincolnwood Teacher Association): **Travis DuPriest/Kevin Conley (Co-Presidents)**

No report.

b. LSSU (Lincolnwood Support Staff Union): **Tammer Gad (President)**

No report.

c.

PALS (People Active with Lincolnwood Schools): **Mihra Seta (President)**

No report.

15. ADMINISTRATIVE REPORTS

a. Superintendent's Report: **Dr. David L. Russo**

i.

District Updates

Superintendent Russo marveled at the creative SD74 student artwork in the Village Hall lobby, as well as

the efforts of the District's Art Staff.

Thanks to the student performers and staff of the spring musical. The public is excited about the upcoming performances.

Superintendent Russo's acknowledgement of the Teacher Appreciation Week efforts organized by the PALS group to recognize the District's teachers and staff. Thanks to everyone involved.

Student registration for the 2023-24 school year remains open. For planning purposes, all families are asked to complete the paperwork. The \$20 lunch incentive expires May 12, 2023.

b. Curriculum and Instruction, Assistant Superintendent's Report: **Dr. Dominick M. Lupo**

I.

Curriculum Department Update

May 5, 2023 is the last day of registration for SD74 Summer Adventures.

- Currently the District has 667 total registrations across all of our classes.

Our Spring MAP window is open and all schools will be completing the Spring MAP.

- Families can expect an email with those results once the window closes.

Thank you to the Board of Education for the adoption of the Carnegie Math program for our Middle School.

- The first initial training for this program will be later this month.

c. Business and Operations, Business Manager/CSBO: **Courtney Whited was absent**

I.

Finance Report - **FEBRUARY 2023**

Assistant Superintendent for Curriculum and Instruction Lupo presented the February 2023 Finance Report.

II. Resolution Ratifying Changes to Niles Township District for Special Education (NTDSE) Articles of Agreement

It was moved by Secretary Vranas and seconded by President Daly that the Lincolnwood School District 74 Board of Education approve the Resolution Ratifying Changes to Niles Township District for Special Education (NTDSE) Articles of Agreement, as presented.

Secretary Vranas gave an overview of the motion mentioning the new Articles of Agreement that will provide the member districts the space needed for satellite classes. Those districts providing use of their space will be compensated through rental fees.

President Daly submitted the motion to a vote and the following vote was recorded:

Ayes: Shah Mandal, Foutris, Theodore, Vranas, Daly

Nays: None

Absent: Boynton

Abstain: Oleniczak

Motion passed.

III.

Bills Payable in the Amount of \$1,985,317.36

Bills reviewed this month by: Jay Oleniczak and Myra A. Foutris

It was moved by Member Foutris and seconded by Member Oleniczak that the Lincolnwood School District

74 Board of Education approve invoices and bills in the amount of \$1,985,317.36.

President Daly submitted the motion to a vote and the following vote was recorded:

Ayes: Shah Mandal, Foutris, Theodore, Vranas, Oleniczak, Daly

Nays: None

Absent: Boynton

Motion passed.

16.

AUDIENCE TO VISITORS

None

17.

ADJOURNMENT

It was moved by Vice President Shah Mandal and seconded by Member Oleniczak to adjourn the Regular meeting of the Lincolnwood School District 74 Board of Education.

President Daly submitted the motion to a vote and the motion passed 8:17 p.m.

Kevin Daly, President

John P. Vranas, Secretary

Press Plus Issue #111 March 2023 - Policy Committee Meeting 4/21/23

1. Action to be taken:

CONSENT

1st READING

STAY IN COMMITTEE

2. Policy Committee to Determine:

Adopt as Presented

Adopt with Additional District Edits

Not Adopt (change "reviewed" date)

Document Status: Draft Update

Operational Services

4:60 Purchases

All purchases in excess of \$10,000 need Board of Education approval.

Adoption of the annual budget authorizes the Superintendent or designee to purchase budgeted supplies, equipment, and services. Purchases of items outside budget parameters require prior Board approval, except in an emergency.

All contracts for supplies, materials, or work involving expenditure in excess of \$25,000 shall be made in accordance with the State law bidding procedure, unless specifically exempted. Sealed, competitive bidding, with certain statutory exceptions, is required. The Superintendent or designee shall prepare the necessary legal notices. The contract will be awarded to the lowest responsible bidder, considering conformity with specifications, delivery terms, quality, and serviceability. The Superintendent or designee shall report the results of the bidding to the Board of Education, together with a recommendation and supporting rationale. Contracts will be awarded by the Board of Education at an official meeting. Bid deposits of 10 percent of the bid amount, assuring good faith in bidding, and performance bonds to the extent of 100 percent of the contract amount, may be required.

The Superintendent shall develop procedures which will allow the purchase of good quality products and services at the lowest cost, with consideration for service, quality, and delivery promptness, and in compliance with State law.

When presenting a contract or purchase for Board approval, the Superintendent or designee shall ensure that it complies with applicable federal and State law, including but not limited to, those specified below:

1. Supplies, materials, or work involving an expenditure in excess of \$25,000 must comply with the State law bidding procedure, [105 ILCS 5/10-20.21](#), unless specifically exempted.
2. Construction, lease, or purchase of school buildings must comply with State law and Board policy 4:150, *Facility Management and Building Programs*.
3. Guaranteed energy savings must comply with [105 ILCS 5/19b-1](#) *et seq.*
4. Third party non-instructional services must comply with [105 ILCS 5/10-22.34c](#).
5. Goods and services that are intended to generate revenue and other remunerations for the District in excess of \$1,000, including without limitation vending machine contracts, sports and other attire, class rings, and photographic services, must comply with [105 ILCS 5/10-20.21](#)(b-5). The Superintendent or designee shall keep a record of: (1) each vendor, product, or service provided, (2) the actual net revenue and non-monetary remuneration from each contract or agreement, and (3) how the revenue was used and to whom the non-monetary remuneration was distributed. The Superintendent or designee shall report this information to the Board by completing the necessary forms that must be attached to the District's annual budget.
6. Any contract to purchase food with a bidder or offeror must comply with [105 ILCS 5/10-20.21](#)(b-10).
7. The purchase of paper and paper products must comply with [105 ILCS 5/10-20.19c](#) and Board policy 4:70, *Resource Conservation*.

8. Each contractor with the District is bound by each of the following:
 - a. In accordance with [105 ILCS 5/10-21.9](#)(f): (1) prohibit any of its employees who is or was found guilty of a criminal offense listed in [105 ILCS 5/10-21.9](#)(c) and [5/21B-80](#)(c) to have direct, daily contact at a District school or school-related activity with one or more student(s); (2) prohibits any of the contractor's employees from having direct, daily contact with one or more students if the employee was found guilty of any offense in [5/21B-80](#)(b) (certain drug offenses) until seven years following the end of the employee's sentence for the criminal offense; and (3) require each of its employees who will have direct, daily contact with student(s) to cooperate during the District's fingerprint-based criminal history records check on him or her.
 - b. In accordance with 105 ILCS 5/22-94: (1) prohibit any of its employees from having *direct contact with children or students* if the contractor has not performed a sexual misconduct related employment history review (EHR) of the employee or if the District objects to the employee's assignment based on the employee's involvement in an instance of sexual misconduct as provided in 105 ILCS 5/22-94(j)(3), which the contractor is required to disclose; (2) discipline, up to and including termination or denial of employment, any employee who provides false information or willfully fails to disclose information required by the EHR; (3) maintain all records of EHRs and provide the District access to such records upon request; and (4) refrain from entering into any agreements prohibited by 105 ILCS 5/22-94(g). [PRESSPlus1](#)
 - c. In accordance with 105 ILCS 5/24-5: (1) concerning each new employee of a contractor that provides services to students or in schools, provide the District with evidence of physical fitness to perform the duties assigned and freedom from communicable disease ~~if the employee will have direct, daily contact with one or more student(s)~~; and (2) require any new or existing employee who ~~has and will have direct, daily contact with one or more~~ provides services to student(s) or in schools to complete additional health examinations as required by the District and be subject to additional health examinations, including tuberculosis screening, as required by the Ill. Dept. ~~artment~~ of Public Health rules or order of a local health official.
9. ~~After 1-1-23, a~~ Any pavement engineering project using a coal tar-based sealant product or high polycyclic aromatic hydrocarbon sealant product for pavement engineering-related use must comply with the Coal Tar Sealant Disclosure Act.
10. Purchases made with federal or State awards must comply with [2 C.F.R. Part 200](#) and [30 ILCS 708/](#), as applicable, and any terms of the award.

The Superintendent or designee shall: (1) execute the reporting and website posting mandates in State law concerning District contracts, and (2) monitor the discharge of contracts, contractors' performances, and the quality and value of services or products being provided.

LEGAL REF.:

[2 C.F.R. Part 200.](#)

[105 ILCS 5/10-20.19c](#), [5/10-20.21](#), [5/10-21.9](#), [5/10-22.34c](#), [5/19b-1](#) et seq., [5/22-94](#), and [5/24-5](#).

[30 ILCS 708/](#), Grant Accountability and Transparency Act.

[410 ILCS 170/](#), Coal Tar Sealant Disclosure Act.

[820 ILCS 130/](#), Prevailing Wage Act.

(Facility Management and Expansion Programs), 4:175 (Convicted Child Sex Offender; Screening; Notifications), 5:90 (Abused and Neglected Child Reporting)

ADOPTED: September 10, 2002

REVISED: February 3, 2022

REVIEWED: February 3, 2022

PRESSPlus Comments

PRESSPlus 1. Updated in response to 105 ILCS 5/22-94, added by P.A. 102-702, eff. 7-1-23. See 4:60-AP4, *Sexual Misconduct Related Employment History Review (EHR) of Contractor Employees*, available at PRESS Online by logging in at www.iasb.com.

For the definition of *sexual misconduct*, see 105 ILCS 5/22-85.5(c), added by P.A. 102-676 and policy 5:120, *Employee Ethics; Code of Professional Conduct; and Conflict of Interest*.

Direct contact with children or students is defined as “the possibility of care, supervision, guidance, or control of children or students or routine interaction with children or students.” 105 ILCS 5/22-94(b), added by P.A. 102-702, eff. 7-1-23. This standard, which triggers the EHR, appears on its face to be broader than the *direct, daily contact* standard that triggers the *complete criminal history records check* in 105 ILCS 5/10-21.9(f). See 5:30-AP2, *Investigations*, 4:60-AP3, *Criminal History Records Check of Contractor Employees*, and 4:60-AP4, *Sexual Misconduct Related Employment History Review (EHR) of Contractor Employees*, for more information. For example, a contracted night custodian who may have some passing, routine interaction with students who are on campus for afterschool events, but does not have direct, daily contact with students triggers an EHR but not necessarily a *complete criminal history records check*. It is less clear if the reverse scenario could arise where a *complete criminal history records check* under 105 ILCS 5/10-21.9(f) would be required but an EHR would not be required. For ease of administration, a district may wish to require contractors to undergo a *complete criminal history records check* whenever the obligation to conduct an EHR is triggered, and vice versa.

105 ILCS 5/22-94(g), added by P.A. 102-702, eff. 7-1-23, prohibits contractors from entering any agreement that: (1) has the effect of suppressing information concerning a pending or completed investigation in which an allegation of sexual misconduct was substantiated, (2) affects the ability of the contractor to report sexual misconduct to the appropriate authorities, or (3) requires the contractor to expunge information about allegations or findings of suspected sexual misconduct, unless an allegation is found to be false, unfounded, or unsubstantiated following an investigation. **Issue 111, March 2023**

Press Plus Issue #111 March 2023 - Policy Committee Meeting 4/21/23

1. Action to be taken:

CONSENT

1st READING

STAY IN COMMITTEE

2. Policy Committee to Determine:

Adopt as Presented

Adopt with Additional District Edits

Not Adopt (change "reviewed" date)

Document Status: Draft Update

General Personnel

5:30 Hiring Process and Criteria

The District hires the most qualified personnel consistent with budget and staffing requirements and in compliance with Board of Education policy on equal employment opportunity and minority recruitment. The Superintendent is responsible for recruiting personnel and making hiring recommendations to the Board. If the Superintendent's recommendation is rejected, the Superintendent must submit another. The Superintendent may select personnel on a short-term basis for a specific project or emergency condition before the Board of Education's approval. No individual will be employed who has been convicted of a criminal offense listed in [105 ILCS 5/21B-80\(c\)](#).

Applicants must complete a District application form in order to be considered for employment.

Job Descriptions

The Board maintains the Superintendent's job description and directs, through policy, the Superintendent, in his or her charge of the District's administration.

The Superintendent shall develop and maintain a current, comprehensive job description for each position, however, a provision in a collective bargaining agreement or individual contract will control in the event of a conflict.

Investigations

The Superintendent or designee shall ensure that a fingerprint-based criminal history records check and a check of the Statewide Sex Offender Database and Violent Offender Against Youth Database is performed on each applicant as required by State law. When the applicant is a successful superintendent candidate who has been offered employment by the Board, the Board President shall ensure that these checks are completed. The Superintendent or designee, or if the applicant is a successful superintendent candidate, then the Board President shall notify an applicant if the applicant is identified in either database. The School Code requires the Board President to keep a conviction record confidential and share it only with the Superintendent, North Cook Intermediate Service Center [Executive Director](#), State Superintendent, State Educator Preparation and Licensure Board, any other person necessary to the hiring decision, the Ill. [Dept. of State Police](#) and/or Statewide Sex Offender Database for purposes of clarifying the information, and/or the Teachers' Retirement System of the State of Illinois when required by law. The Board reserves its right to authorize additional background inquiries beyond a fingerprint-based criminal history records check when it deems it appropriate to do so, in accordance with applicable laws.

Each newly hired employee must complete a U.S. Citizenship and Immigration Services Form as required by federal law.

The District retains the right to discharge any employee whose criminal background investigation reveals a conviction for committing or attempting to commit any of the offenses outlined in [105 ILCS 5/21B-80](#) or who falsifies, or omits facts from, his or her employment application or other employment documents. If an indicated finding of abuse or neglect of a child has been issued by the Ill. Department of Children and Family Services or by a child welfare agency of another jurisdiction for any applicant

for student teaching, applicant for employment, or any District employee, then the Board must consider that person's status as a condition of employment.

The Superintendent shall ensure that the District does not engage in any investigation or inquiry prohibited by law and complies with each of the following:

1. The District uses an applicant's credit history or report from a consumer reporting agency only when a satisfactory credit history is an established bona fide occupational requirement of a particular position.
2. The District does not screen applicants based on their current or prior wages or salary histories, including benefits or other compensation, by requiring that the wage or salary history satisfy minimum or maximum criteria.
3. The District does not request or require a wage or salary history as a condition of being considered for employment, being interviewed, continuing to be considered for an offer of employment, an offer of employment, or an offer of compensation.
4. The District does not request or require an applicant to disclose wage or salary history as a condition of employment.
5. The District does not ask an applicant or applicant's current or previous employers about wage or salary history, including benefits or other compensation, unless the applicant's wage or salary history is a matter of public record, or is contained in a document completed by the applicant's current or former employer and then made available to the public by the employer, or then submitted or posted by the employer to comply with State or federal law; or the applicant is a current employee applying for a position with the same current employer.
6. The District does not ask an applicant or applicant's previous employers about claim(s) made or benefit(s) received under the Workers' Compensation Act.
7. The District does not request of an applicant or employee access in any manner to his or her personal online account, such as social networking websites, including a request for passwords to such accounts.
8. The District provides equal employment opportunities to all persons. See policy 5:10, *Equal Employment Opportunity and Minority Recruitment*.

Sexual Misconduct Related Employment History Review (EHR) [PRESSPlus1](#)

Prior to hiring an applicant for a position involving *direct contact with children or students*, [PRESSPlus2](#) the Superintendent shall ensure that an EHR is performed as required by State law. When the applicant is a superintendent candidate, the Board President shall ensure that the EHR is initiated before a successful superintendent candidate is offered employment by the Board.

Physical Examinations

Each new employee must furnish evidence of physical fitness to perform assigned duties and freedom from communicable disease. The physical fitness examination must be performed by a physician licensed in Illinois, or any other state, to practice medicine and surgery in any of its branches, a licensed advanced practice registered nurse, or a licensed physician assistant who has been delegated the authority by his or her supervising physician to perform health examinations. The employee must have the physical examination performed no more than 90 days before submitting evidence of it to the District.

Any employee may be required to have an additional examination by a physician who is licensed in Illinois to practice medicine and surgery in all its branches, a licensed advanced practice registered nurse, or a licensed physician assistant who has been delegated the authority by his or her

supervising physician to perform health examinations, if the examination is job-related and consistent with business necessity. The Board will pay the expenses of any such examination.

Orientation Program

The District's staff will provide an orientation program for new employees to acquaint them with the District's policies and procedures, the school's rules and regulations, and the responsibilities of their position. Before beginning employment, each employee must sign the *Acknowledgement of Mandated Reporter Status* form as provided in policy 5:90, *Abused and Neglected Child Reporting*.

LEGAL REF.:

[42 U.S.C. §12112](#), Americans with Disabilities Act; [29 C.F.R. Part 1630](#).

[15 U.S.C. § 1681](#) *et seq.*, Fair Credit Reporting Act.

[8 U.S.C. §1324a](#) *et seq.*, Immigration Reform and Control Act.

[105 ILCS 5/10-16.7](#), [5/10-20.7](#), [5/10-21.4](#), [5/10-21.9](#), [5/10-22.34](#), [5/10-22.34b](#), [5/21B-10](#), [5/21B-80](#), [5/21B-85](#), [5/22-6.5](#), [5/22-94](#), and [5/24-5](#).

[20 ILCS 2630/3.3](#), Criminal Identification Act.

[820 ILCS 55/](#), Right to Privacy in the Workplace Act.

[820 ILCS 70/](#), Employee Credit Privacy Act.

Duldulao v. St. Mary of Nazareth Hospital, 136 Ill. App. 3d 763 (1st Dist. 1985), *aff'd in part and remanded* 115 Ill.2d 482 (Ill. 1987).

Kaiser v. Dixon, 127 Ill. App. 3d 251 (2nd Dist. 1984).

Molitor v. Chicago Title & Trust Co., 325 Ill. App. 124 (1st Dist. 1945).

CROSS REF.: 3:50 (Administrative Personnel Other than the Superintendent), 4:175 (Convicted Child Sex Offender; Criminal Background Check and/or Screen; Notifications), 5:10 (Equal Employment Opportunity and Minority Recruitment), 5:40 (Communicable and Chronic Infectious Disease), 5:90 (Abused and Neglected Child Reporting), [5:120 \(Employee Ethics; Code of Professional Conduct; and Conflict of Interest\)](#), 5:125 (Personal Technology and Social Media; Usage and Conduct), 5:220 (Substitute Teachers), 5:280 (Duties and Qualifications)

ADOPTED: September 10, 2002

REVISED: February 3, 2022

REVIEWED: February 3, 2022

PRESSPlus Comments

PRESSPlus 1. Updated in response to 105 ILCS 5/22-94, added by P.A. 102-702, eff. 7-1-23, requiring districts to initiate an EHR prior to hiring an applicant who will have *direct contact with children or students*. See sample administrative procedure 5:30-AP3, *Sexual Misconduct Related Employment History Review (EHR)*, available at PRESS Online by logging in at www.iasb.com, for

the process, timing, and positions requiring an EHR. See policy 4:60, *Purchases and Contracts*, and sample administrative procedure 4:60-AP4, *Sexual Misconduct Related Employment History Review (EHR) of Contractor Employees*, for EHR requirements for employees of contractors who have *direct contact with children or students*. **Issue 111, March 2023**

PRESSPlus 2. *Direct contact with children or students* is defined as “the possibility of care, supervision, guidance, or control of children or students or routine interaction with children or students.” 105 ILCS 5/22-94(b), added by P.A. 102-702, eff. 7-1-23. **Issue 111, March 2023**

Press Plus Issue #111 March 2023 - Policy Committee Meeting 4/21/23

1. Action to be taken:

CONSENT

1st READING

STAY IN COMMITTEE

2. Policy Committee to Determine:

Adopt as Presented

Adopt with Additional District Edits

Not Adopt (change "reviewed" date)

Document Status: Draft Update

General Personnel

5:90 Abused and Neglected Child Reporting

Any District employee who suspects or receives knowledge that a student may be an abused or neglected child shall: (1) immediately report or cause a report to be made to the Ill. Dept. of Children and Family Services (DCFS) on its Child Abuse Hotline 1-800-25-ABUSE (1-800-252-2873) (within Illinois); 1-217-524-2606 (outside of Illinois); or 1-800-358-5117 (TTY), and (2) follow directions given by DCFS concerning filing a written report within 48 hours with the nearest DCFS field office. Any District employee who believes a student is in immediate danger of harm, shall first call 911. The employee shall also promptly notify the Superintendent or Building Principal that a report has been made. The Superintendent or designee shall notify local law enforcement. Negligent failure to report occurs when a District employee personally observes an instance of suspected child abuse or neglect and reasonably believes, in his or her professional or official capacity, that the instance constitutes an act of child abuse or neglect under the Abused and Neglected Child Reporting Act (ANCRA) and he or she, without willful intent, fails to immediately report or cause a report to be made of the suspected abuse or neglect to DCFS.

Any District employee who discovers child pornography on electronic and information technology equipment shall immediately report it to local law enforcement, the National Center for Missing and Exploited Children's CyberTipline 1-800-THE-LOST (1-800-843-5678) or online at report.cybertip.org/ or www.missingkids.org. The Superintendent or Building Principal shall also be promptly notified of the discovery and that a report has been made.

Any District employee who observes any act of hazing that does bodily harm to a student must report that act to the Building Principal, Superintendent, or designee who will investigate and take appropriate action. If the hazing results in death or great bodily harm, the employee must first make the report to law enforcement and then to the Superintendent or Building Principal. Hazing is defined as any intentional, knowing, or reckless act directed to or required of a student for the purpose of being initiated into, affiliating with, holding office in, or maintaining membership in any group, organization, club, or athletic team whose members are or include other students.

Abused and Neglected Child Reporting Act (ANCRA), School Code, and Erin's Law Training

The Superintendent or designee shall provide staff development opportunities for District employees in the detection, reporting, and prevention of child abuse and neglect.

All District employees shall:

1. Before beginning employment, sign the *Acknowledgement of Mandated Reporter Status* form provided by DCFS. The Superintendent or designee shall ensure that the signed forms are retained.
2. Complete mandated reporter training as required by law within three months of initial employment and at least every three years after that date.
3. Complete an annual evidence-informed training related to child sexual abuse, grooming behaviors (including sexual misconduct as defined in Faith's Law), [PRESSPlus1](#) and boundary

violations as required by law and policy 5:100, *Staff Development Program*.

The Superintendent or designee will display DCFS-issued materials that list the DCFS toll-free telephone number and methods for making a report under ANCRA in a clearly visible location in each school building.

Alleged Incidents of Sexual Abuse: Investigations

An *alleged incident of sexual abuse* is an incident of sexual abuse of a child, as defined in [720 ILCS 5/11-9.1A](#), that is alleged to have been perpetrated by school personnel, including a school vendor or volunteer, that occurred: on school grounds during a school activity; or outside of school grounds or not during a school activity.

If a District employee reports an alleged incident of sexual abuse to DCFS and DCFS accepts the report for investigation, DCFS will refer the matter to the local Children's Advocacy Center (CAC). The Superintendent or designee will implement procedures to coordinate with the CAC.

DCFS and/or the appropriate law enforcement agency will inform the District when its investigation is complete or has been suspended, as well as the outcome of its investigation. The existence of a DCFS and/or law enforcement investigation will not preclude the District from conducting its own parallel investigation into the alleged incident of sexual abuse in accordance with policy 7:20, *Harassment of Students Prohibited*.

Special Superintendent Responsibilities

The Superintendent shall execute the requirements in Board policy 5:150, *Personnel Records*, whenever another school district requests a reference concerning an applicant who is or was a District employee and was the subject of a report made by a District employee to DCFS.

When the Superintendent has reasonable cause to believe that a license holder (1) committed an intentional act of abuse or neglect with the result of making a child an abused child or a neglected child under ANCRA or an act of sexual misconduct under *Faith's Law*, [PRESSPlus2](#) and (2) that act resulted in the license holder's dismissal or resignation from the District, ~~he or she~~ the Superintendent shall notify the State Superintendent and the appropriate Intermediate Service Center Executive Director in writing, providing the Ill. Educator Identification Number as well as a brief description of the misconduct alleged. The Superintendent must make the report within 30 days of the dismissal or resignation and mail a copy of the notification to the license holder.

The Superintendent shall develop procedures for notifying a student's parents/guardians when a District employee, contractor, or agent is alleged to have engaged in sexual misconduct with the student as defined in *Faith's Law*. The Superintendent shall also develop procedures for notifying the student's parents/guardians when the Board takes action relating to the employment of the employee, contractor, or agent following the investigation of sexual misconduct. Notification shall not occur when the employee, contractor, or agent alleged to have engaged in sexual misconduct is the student's parent/guardian, and/or when the student is at least 18 years of age or emancipated. [PRESSPlus3](#)

The Superintendent shall execute the recordkeeping requirements of *Faith's Law*. [PRESSPlus4](#)

Special School Board Member Responsibilities

Each individual Board member must, if an allegation is raised to the member during an open or closed Board meeting that a student is an abused child as defined in ANCRA, direct or cause the Board to direct the Superintendent or other equivalent school administrator to comply with ANCRA's

requirements concerning the reporting of child abuse.

If the Board determines that any District employee, other than an employee licensed under [105 ILCS 5/21B](#), has willfully or negligently failed to report an instance of suspected child abuse or neglect as required by ANCRA, the Board may dismiss that employee immediately.

When the Board learns that a licensed teacher was convicted of any felony, it must promptly report it to the State agencies listed in policy 2:20, *Powers and Duties of the Board of Education; Indemnification*.

LEGAL REF.:

[20 U.S.C. §7926](#), Elementary and Secondary Education Act.

105 ILCS 5/10-21.9, 5/10-23.13, and 5/21B-85, [5/22-85.5](#), and [5/22-85.10](#).

[20 ILCS 1305/1-1](#) et seq., Department of Human Services Act.

[325 ILCS 5/](#), Abused and Neglected Child Reporting Act.

[720 ILCS 5/12C-50.1](#), Criminal Code of 2012.

CROSS REF.: 2:20 (Powers and Duties of the Board of Education; Indemnification), 3:40 (Superintendent), 3:50 (Administrative Personnel Other Than the Superintendent), 3:60 (Administrative Responsibility of the Building Principal), [4:60 \(Purchases and Contracts\)](#), 4:165 (Awareness and Prevention of Child Sexual Abuse and Grooming Behaviors), 5:20 (Workplace Harassment Prohibited), 5:30 (Hiring Process and Criteria), 5:100 (Staff Development Program), 5:120 (Employee Ethics; [Code of Professional](#) Conduct; and Conflict of Interest), 5:150 (Personnel Records), 5:200 (Terms and Conditions of Employment and Dismissal), 5:290 (Employment Termination and Suspensions), 6:120 (Education of Children with Disabilities), 6:250 (Community Resource Persons and Volunteers), 7:20 (Harassment of Students Prohibited), 7:150 (Agency and Police Interviews)

ADOPTED: January 12, 2016

REVISED: March 3, 2022

REVIEWED: March 3, 2022

PRESSPlus Comments

PRESSPlus 1. *Sexual misconduct* under *Faith's Law* defined in 105 ILCS 5/22-85.5(c), added by P.A. 102-676.

The Abused and Neglected Child Reporting Act (ANCRA) covers abuse and neglect of children. 325 ILCS 5/3. The Dept. of Human Services Act (DHSA) covers abuse and neglect of adult students with a disability. 20 ILCS 1305/1-17(b). Abuse may be generally understood as any physical or mental injury or sexual abuse inflicted on a child or adult student with a disability other than by accidental means or creation of a risk of such injury or abuse by a person who is responsible for the welfare of a child or adult student with a disability. Neglect may be generally understood as abandoning a child or adult student with a disability or failing to provide the proper support, education, medical, or remedial care required by law by one who is responsible for the child's or adult student with a disability's welfare.

Abuse covered by ANCRA also includes *grooming* as defined in the Ill. Criminal Code of 2012 (720 ILCS 5/11-25). 325 ILCS 5/3(i), added by P.A. 102-676 (a/k/a *Faith's Law*).

The School Code goes further and prohibits school employees from engaging in *grooming behaviors* and *sexual misconduct*. 105 ILCS 5/10-23.13(b), amended by P.A. 102-610 (a/k/a *Erin's Law*); 105 ILCS 5/22-85.5(c), added by P.A. 102-676 (a/k/a *Faith's Law*). To streamline implementation, policy 5:120, *Employee Ethics; Code of Professional Conduct; and Conflict of Interest*, defines prohibited *grooming behaviors* to include *sexual misconduct* and it explicitly prohibits employees from engaging in *grooming*, *grooming behaviors*, and *sexual misconduct*. While it is possible for low-level *grooming behaviors* and/or *sexual misconduct* to not amount to grooming prohibited by ANCRA, best practice is to report suspected *grooming behaviors* and *sexual misconduct* to DCFS. **Issue 111, March 2023**

PRESSPlus 2. Updated in response to 105 ILCS 5/10-21.9(e-5), amended by P.A. 102-702, eff. 7-1-23. **Issue 111, March 2023**

PRESSPlus 3. Updated in response to 105 ILCS 5/22-85.10, added by P.A. 102-702, eff. 7-1-23. See sample procedure 5:90-AP2, *Parent/Guardian Notification of Sexual Misconduct*, available at PRESS Online by logging in at www.iasb.com. **Issue 111, March 2023**

PRESSPlus 4. Updated in response to 105 ILCS 5/22-94(e), added by P.A. 102-702, eff. 7-1-23. See sample procedure 5:150-AP, *Personnel Records*, available at PRESS Online by logging in at www.iasb.com. **Issue 111, March 2023**

Press Plus Issue #111 March 2023 - Policy Committee Meeting 4/21/23

1. Action to be taken:

CONSENT

1st READING

STAY IN COMMITTEE

2. Policy Committee to Determine:

Adopt as Presented

Adopt with Additional District Edits

Not Adopt (change "reviewed" date)

Document Status: Draft Update

General Personnel

5:150 Personnel Records

Prospective Employer Inquiries Concerning a Current or Former Employee's Job Performance

The Superintendent or designee shall manage a process for responding to inquiries by a prospective employer concerning a current or former employee's job performance. The Superintendent shall:

1. Execute the requirements in the Abused and Neglected Child Reporting Act whenever another school district asks for a reference concerning an applicant who is or was a District employee and was the subject of a report made by a District employee to Ill. Dept. of Children and Family Services (DCFS); and
2. Comply with the federal law prohibiting the District from providing a recommendation of employment for an employee, contractor, or agent that District knows, or has probable cause to believe, has engaged in sexual misconduct with a student or minor in violation of the law, but the Superintendent or designee may follow routine procedures regarding the transmission of administrative or personnel files for that employee.
3. Manage the District's responses to employer requests for sexual misconduct related employment history review (EHR) information in accordance with Faith's Law. [PRESSPlus1](#)

When requested for information about an employee by an entity other than a prospective employer, the District will only confirm position and employment dates unless the employee has submitted a written request to the Superintendent or designee.

Maintenance and Access to Records

Please refer to the current "Agreement between the Board of Education, School District #74, Lincolnwood, Illinois, and the Lincolnwood Teacher's Association, Local 1274 IFT/AFT, AFL-CIO and the Lincolnwood Support Staff Union, Local 1274 IFT/AFT, AFL-CIO for additional information, if applicable."

For employees not covered by this agreement:

The Superintendent or designee shall manage the maintenance of personnel records in accordance with State and federal law and Board policy. Records, as determined by the Superintendent, are retained for all employment applicants, employees, and former employees given the need for the District to document employment-related decisions, evaluate program and staff effectiveness, and comply with government record-keeping and reporting requirements. Personnel records shall be maintained in the District's administrative office, under the Superintendent's direct supervision.

Access to personnel records is available as follows:

1. An employee will be given access to his or her personnel records according to State law and guidelines developed by the Superintendent.
2. An employee's supervisor or other management employee who has an employment or business-related reason to inspect the record is authorized to have access.

3. Anyone having the respective employee's written consent may have access.
4. Access will be granted to anyone authorized by State or federal law to have access.
5. All other requests for access to personnel information are governed by Board policy 2:250, *Access to District Public Records*.

LEGAL REF.:

[20 U.S.C. §7926](#).

[105 ILCS 5/22-94](#).

[325 ILCS 5/4](#), Abused and Neglected Child Reporting Act.

[745 ILCS 46/10](#), Employment Record Disclosure Act.

[820 ILCS 40/](#), Personnel Record Review Act.

[23 Ill.Admin.Code §1.660](#).

CROSS REF.: 2:250 (Access to District Public Records), 5:90 (Abused and Neglected Child Reporting), 7:340 (Student Records)

ADOPTED: October 3, 2006

REVISED: February 3, 2022

REVIEWED: February 3, 2022

PRESSPlus Comments

PRESSPlus 1. Updated in response to 105 ILCS 5/22-94(e), added by P.A. 102-702, eff. 7-1-23. **Issue 111, March 2023**

Press Plus Issue #111 March 2023 - Policy Committee Meeting 4/21/23

1. Action to be taken:

CONSENT

1st READING

STAY IN COMMITTEE

2. Policy Committee to Determine:

Adopt as Presented

Adopt with Additional District Edits

Not Adopt (change "reviewed" date)

Document Status: Draft Update

Instruction

6:135 Accelerated Placement Program

The District provides an Accelerated Placement Program (APP). The APP advances the District's goal of providing educational programs with opportunities for each student to develop to his or her maximum potential. The APP provides an educational setting with curriculum options usually reserved for students who are older or in higher grades than the student participating in the APP. APP options include, but may not be limited to: (a) accelerating a student in a single subject; (b) other grade-level acceleration; and (c) early entrance to kindergarten or first grade. Participation in the APP is open to all students who demonstrate high ability and who may benefit from accelerated placement. It is not limited to students who have been identified as gifted and talented. Eligibility to participate in the District's APP shall not be conditioned upon the protected classifications identified in Board policy 7:10, *Equal Educational Opportunities*, or any factor other than the student's identification as an accelerated learner.

The Superintendent or designee shall implement an APP that includes:

1. Decision-making processes that are fair, equitable, and involve multiple individuals, e.g. District administrators, teachers, and school support personnel, and a student's parent(s)/guardian(s);
2. Notification processes that notify a student's parent(s)/guardian(s) of a decision affecting a student's participation in the APP; and
3. Assessment processes that include multiple valid, reliable indicators; and
4. ~~By the fall of 2023, the automatic enrollment, in the following school term, of a student into the next most rigorous level of advanced coursework offered by the high school if the student meets or exceeds State standards in English language arts, mathematics, or science on a State assessment administered under 105 ILCS 5/2-3.64a-5, as follows:~~ PRESSPlus1
 - a. ~~A student who meets or exceeds State standards in English language arts shall be automatically enrolled into the next most rigorous level of advanced coursework in English, social studies, humanities, or related subjects.~~
 - b. ~~A student who meets or exceeds State standards in mathematics shall be automatically enrolled into the next most rigorous level of advanced coursework in mathematics.~~
 - c. ~~A student who meets or exceeds State standards in science shall be automatically enrolled into the next most rigorous level of advanced coursework in science.~~

The Superintendent or designee may annually notify the community, parent(s)/guardian(s), students, and school personnel about the APP, the process for referring a student for possible evaluation for accelerated placement, and the methods used to determine whether a student is eligible for accelerated placement, including strategies to reach groups of students and families who have been historically underrepresented in accelerated placement programs and advanced coursework. Notification may: (a) include varied communication methods, such as student handbooks and District or school websites; and (b) be provided in multiple languages, as appropriate.

LEGAL REF.:

[23 Ill.Admin.Code Part 227](#), Gifted Education.

CROSS REF.: 6:10 (Educational Philosophy and Objectives), 6:130 (Program for the Gifted), 7:10 (Equal Educational Opportunities), 7:50 (School Admissions and Student Transfers To and From Non-District Schools)

ADOPTED: October 4, 2018

REVISED: March 3, 2022

REVIEWED: March 3, 2022

PRESSPlus Comments

PRESSPlus 1. Updated in response to ISBE's *Accelerated Placement Policy Guidance for Districts Frequently Asked Questions* (September 2022), at: www.isbe.net/Documents/Accelerated-Placement-Act-FAQ.pdf, which asserts this provision is limited to “[d]istricts with grades 9-12.” **Issue 111, March 2023**

Press Plus Issue #111 March 2023 - Policy Committee Meeting 4/21/23

1. Action to be taken:

CONSENT

1st READING

STAY IN COMMITTEE

2. Policy Committee to Determine:

Adopt as Presented

Adopt with Additional District Edits

Not Adopt (change "reviewed" date)

Document Status: Draft Update

Instruction

6:230 Library Media Program

The Superintendent or designee shall manage the District's library media program to comply with, (1) State law and Ill. State Board of Education (ISBE) rule, and (2) the following standards:

1. The program includes an organized collection of resources available to students and staff to supplement classroom instruction, foster reading for pleasure, enhance information literacy, and support research, as appropriate to students of all abilities in the grade levels served.
2. Financial resources for the program's resources and supplies are allocated to meet students' needs.
3. Students in all grades served have equitable access to library media resources.
4. The advice of an individual who is qualified according to ISBE rule is sought regarding the overall direction of the program, including the selection and organization of materials, provision of instruction in information and technology literacy, and structuring the work of library paraprofessionals.
5. Staff members are invited to recommend additions to the collection.
6. Students may freely select resource center materials as well as receive guided selection of materials appropriate to specific, planned learning experiences.
7. The program is guided by the principles of the American Library Association's *Library Bill of Rights* and its interpretation for school libraries. [PRESSPlus1](#)

Parents/guardians, employees, and community members who believe that library media program resources violate rights guaranteed by any law or Board policy may file a complaint using Board policy 2:260, *Uniform Grievance Procedure*. [PRESSPlus2](#)

The Superintendent or designee shall establish criteria consistent with this policy for the review of objections. Parents/guardians, employees, and community members with suggestions or complaints about library media program resources may complete a *Library Media Resource Objection Form*. The Superintendent or designee shall inform the parent/guardian, employee, or community member, as applicable, of the District's decision. [PRESSPlus3](#)

LEGAL REF:

[23 Ill.Admin.Code §1.420\(o\)](#).

CROSS REF.: 6:60 (Curriculum Content), 6:170 (Title I Programs), 6:210 (Instructional Materials)

ADOPTED: December 2, 2008

REVISED:

REVIEWED: September 6, 2018

PRESSPlus Comments

PRESSPlus 1. Optional. The American Library Association's (ALA) *Library Bill of Rights* includes the following:

1. Books and other library resources should be provided for the interest, information, and enlightenment of all people of the community the library serves. Materials should not be excluded because of the origin, background, or views of those contributing to their creation.
2. Libraries should provide materials and information presenting all points of view on current and historical issues. Materials should not be proscribed or removed because of partisan or doctrinal disapproval.
3. Libraries should challenge censorship in the fulfillment of their responsibility to provide information and enlightenment.
4. Libraries should cooperate with all persons and groups concerned with resisting abridgment of free expression and free access to ideas.
5. A person's right to use a library should not be denied or abridged because of origin, age, background, or views.
6. Libraries which make exhibit spaces and meeting rooms available to the public they serve should make such facilities available on an equitable basis, regardless of the beliefs or affiliations of individuals or groups requesting their use.
7. All people, regardless of origin, age, background, or views, possess a right to privacy and confidentiality in their library use.
8. Libraries should advocate for, educate about, and protect people's privacy, safeguarding all library use data, including personally identifiable information.

See <https://www.ala.org/advocacy/intfreedom/librarybill> and its interpretation for school libraries at: <https://www.ala.org/advocacy/intfreedom/librarybill/interpretations/accessresources>. The ALA's interpretation of its *Library Bill of Rights* acknowledges that the educational level and program of the school necessarily shape the resources and services of a school library, but it states that the principles of the *Library Bill of Rights* apply equally to all libraries, including school libraries. **Issue 111, March 2023**

PRESSPlus 2. Limiting the scope of complainants in this policy to parents/guardians, employees, and community members aligns with sample policy 2:260, *Uniform Grievance Procedure*. **Issue 111, March 2023**

PRESSPlus 3. Updated in response to subscriber and Ill. Council of School Attorneys member feedback regarding management of library book challenges. The issue of school library book removals is an unsettled area of law that is often litigated; consult the board attorney for advice regarding challenges to school library books or other library resources. In the only U.S. Supreme Court case to address this issue, Island Trees Union Free Sch. Dist. No. 26 v. Pico, 457 U.S. 852 (1982), the Court issued a plurality (not a majority) opinion finding a board could not remove books it had characterized as "anti-American, anti-Christian, anti-Semitic, and just plain filthy," if the removal was motivated by partisan or political reasons; to do so would violate students' Constitutional right to receive information and ideas. Four dissenting justices, however, disagreed that students have a right to receive information and ideas under the First Amendment and would have deferred to the judgment of the local school board.

See sample administrative procedure 6:230-AP, *Responding to Complaints About Library Media Resources*, and sample exhibit 6:230-AP, E, *Library Media Resource Objection Form*, available at PRESS Online by logging in at www.iasb.com. **Issue 111, March 2023**

Press Plus Issue #111 March 2023 - Policy Committee Meeting 4/21/23

1. Action to be taken:

CONSENT

1st READING

STAY IN COMMITTEE

2. Policy Committee to Determine:

Adopt as Presented

Adopt with Additional District Edits

Not Adopt (change "reviewed" date)

Document Status: Draft Update

Instruction

6:260 Complaints About Curriculum, Instructional Materials, and Programs

Parents/guardians have the right to inspect any instructional material used as part of their child's educational curriculum pursuant to Board of Education policy 7:15, *Student and Family Privacy Rights*.

Persons Parents/guardians, employees, and community members [PRESSPlus1](#) who believe that curriculum, instructional materials, or programs violate rights guaranteed by any law or Board policy ~~should~~ may file a complaint using Board policy 2:260, *Uniform Grievance Procedure*.

Persons Parents/guardians, employees, and community members with ~~all~~ other suggestions or complaints about curriculum, instructional materials, or programs should complete a *Curriculum Objection Form*. A parent/guardian may request that his/her child be exempt from using a particular instructional material or program by completing a *Curriculum Objection Form*. The Superintendent or designee shall establish criteria for the review of objections and inform the parent/guardian, employee, or community member, as applicable, of the District's decision. [PRESSPlus2](#)

LEGAL REF.:

[20 U.S.C. §1232h](#), Protection of Pupil Rights Amendment.

CROSS REF.: 2:260 (Uniform Grievance Procedure), 7:15 (Student and Family Privacy Rights), 8:110 (Public Suggestions and Concerns)

ADOPTED: October 18, 2012

REVISED: September 2, 2021

REVIEWED: September 2, 2021

PRESSPlus Comments

PRESSPlus 1. Updated to limit the scope of complainants in this policy to parents/guardians, employees, and community members in alignment with sample **PRESS** policy 2:260, *Uniform Grievance Procedure*. **Issue 110, October 2022**

PRESSPlus 2. Optional sentence; updated in response to **PRESS** Advisory Board (PAB) member feedback regarding the need for districts to have processes in place to address an increasing number of curriculum objections. It strengthens the policy's connection to IASB's *Foundational Principles of Effective Governance*. See www.iasb.com/conference-training-and-events/training/training-resources/foundational-principles-of-effective-governance. For criteria that can be used in reviewing curriculum objections, see sample administrative procedure, 6:260-AP, *Responding to Complaints About Curriculum, Instructional Materials, and Programs*, available at **PRESS** Online by logging in at www.iasb.com. **Issue 110, October 2022**

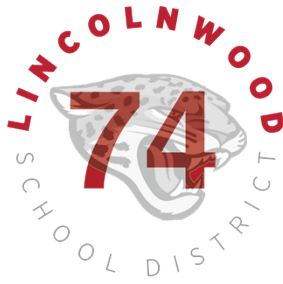

Executive Summary Board of Education Meeting

DATE: June 1, 2023

TOPIC: Transportation Contract 2023-24 with First Student, Inc.

PREPARED BY: Courtney Whited

Recommended for:

- Action
- Discussion
- Information

Purpose/Background:

The Board approves all contracts over \$10,000. The District Legal Counsel has reviewed this amendment and found it to be acceptable.

Fiscal Impact:

A 3.75% rate increase was applied for FY24 transportation services.

The prior year’s increase was 7.0%.

Lincolnwood School District #74		
	2022-23	2023-24
AMRate per Route - Single	\$ 135.47	\$ 140.55
AMRate per Route - Dual	\$ 67.72	\$ 70.26
AMRate per Route - Dual Paired with District 219 credit back to District	\$ 116.71	\$ 121.09
PM Rate per Route - Single	\$ 135.47	\$ 140.55
PM Rate per Route - Dual	\$ 67.72	\$ 70.26
PM Rate per Route - Dual Paired with District 219 credit back to District	\$ 116.71	\$ 121.09
Mid-Day Rate per Route (Pre-Kingergarten)	\$ 95.56	\$ 99.15
Before School Activity Rate per route	\$ 107.82	\$ 111.86
After School Activity Rate per Route	\$ 107.82	\$ 111.86
Extracurricular Charter Rate per hour	\$ 63.71	\$ 66.10
*The above prices are inclusive of the District 219 equipment surcharge		
District 219 equipment surcharge AM or PM route	\$ 43.98	\$ 45.63
District 219 equipment surcharge Midday or Activity route	\$ 10.99	\$ 11.41

Recommendation:

The Finance Committee concurs with the Administration to recommend to the Board of Education to accept this Amendment from First Student, Inc. for transportation services with a 3.75% rate increase on current rates effective August 1, 2023 through July 31, 2024

**AMENDMENT AND EXTENSION TO THE PUPIL
TRANSPORTATION SERVICES AGREEMENT BETWEEN
LINCOLNWOOD SCHOOL DISTRICT 74 AND FIRST STUDENT, INC.**

THIS AMENDMENT ("Amendment") Is made by and effective as of the 1st day of June, 2023 by and between LINCOLNWOOD SCHOOL DISTRICT 74, with principal offices at 6950 N. East Prairie Road Lincolnwood, IL 60712, hereinafter called "DISTRICT" and FIRST STUDENT, INC., with Its national headquarters at 600 Vine St., Cincinnati, OH 45202 and principal business offices for purposes of this Agreement located at 1717 Park Street, Suite 225, Naperville, IL 60563 hereinafter called "CONTRACTOR" and collectively called "Parties."

WHEREAS, the CONTRACTOR was the successful bidder on March 16, 2015 and operated the student transportation services for the DISTRICT for the school years of 2015-16 through 2017-18 per the specifications provided in the bid process and all contingencies placed upon the bid specifications by the CONTRACTOR in its proposal and executive summary (the "Agreement").

WHEREAS, the Parties previously amended certain provisions of the Agreement and extended its term annually effective August 1, 2018, August 1, 2020, August 1, 2021, and August 1, 2022 respectively.

WHEREAS, the Parties desire to amend certain provisions of the Agreement again and extend its term effective August 1, 2023.

NOW, THEREFORE, the Parties mutually agree as follows:

All terms used herein, unless otherwise defined in this Amendment, shall have the same meaning as set forth in the Agreement. Following the effective date of this Amendment, future references to the Agreement in any communication or document between the DISTRICT and CONTRACTOR shall mean the Agreement incorporating the changes and/or additions in this Amendment.

1. TERM: The term of the Agreement shall extend for one additional year commencing August 1, 2023 and continuing through July 31, 2024; thereafter this Agreement may be extended on a year-to-year basis by mutual agreement of the Parties, subject to the operation of 105 ILCS 5/29-6.1, as amended from time to time.

2. COMPENSATION: Commencing August 1, 2023, the rates of compensation will increase by 3.75% for the 2023-24 school year. Rates are listed in attached Exhibit A and are based on the current number of routes.

3. ENTIRE AGREEMENT: The terms of this Amendment, the original Agreement, and all other amendments set forth the entire Agreement between District and Contractor concerning the subject matter hereof. To the extent that the terms of this Amendment supplement, amend or replace terms from the original Agreement, the terms of this Amendment shall control.

4. NOTICE TO PARTIES: All notices to be given by the parties to this Agreement shall be in writing and serviced by depositing same in the United States Mail, certified mail.

Notices to DISTRICT shall be addressed to:

Courtney Whited
Business Manager/CSBO
Lincolnwood School District 74
6950 N. East Prairie Rd.
Lincolnwood, IL 60712

Notices to CONTRACTOR shall be addressed to:

Mr. Jason Kierna
Region Vice President
First Student, Inc. 1717 Park Street, Suite 225
Naperville, IL 60563

With a copy to:

General Counsel
First Student, Inc.
600 Vine St.
Cincinnati, OH 45202

IN WITNESS WHEREOF, this Amendment has been signed and executed in duplicate on behalf of the parties hereto by persons duly authorized on the day and year first written above.

**LINCOLNWOOD SCHOOL
DISTRICT 74**

FIRST STUDENT

By: _____

By:  _____

Title: _____

Title: Sr. Vice President _____

Attest:

Attest:

By: _____

By:  _____

Exhibit A

Lincolnwood School District #74		
	2022-23	2023-24
AM Rate per Route - Single	\$ 135.47	\$ 140.55
AM Rate per Route - Dual	\$ 67.72	\$ 70.26
AM Rate per Route - Dual Paired with District 219 credit back to District	\$ 116.71	\$ 121.09
PM Rate per Route - Single	\$ 135.47	\$ 140.55
PM Rate per Route - Dual	\$ 67.72	\$ 70.26
PM Rate per Route - Dual Paired with District 219 credit back to District	\$ 116.71	\$ 121.09
Mid-Day Rate per Route (Pre-Kingergarten)	\$ 95.56	\$ 99.15
Before School Activity Rate per route	\$ 107.82	\$ 111.86
After School Activity Rate per Route	\$ 107.82	\$ 111.86
Extracurricular Charter Rate per hour	\$ 63.71	\$ 66.10
*The above prices are inclusive of the District 219 equipment surcharge		
District 219 equipment surcharge AM or PM route	\$ 43.98	\$ 45.63
District 219 equipment surcharge Midday or Activity route	\$ 10.99	\$ 11.41

TRANSPORTATION CONTRACT

AGREEMENT made the 29th day of April, 2015, between
Lincolnwood SCHOOL DISTRICT FIRST STUDENT, INC.
(hereinafter referred to as the "District") and ~~CONTRACTOR, INC.~~ (hereinafter referred to
as the "Contractor").

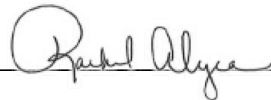
Term of Contract.

The Contractor, for and in consideration of the payments to be made as hereinafter set forth in the Cost Schedule attached hereto as Appendix A, hereby agrees to transport students that the District must transport by law and students that have independently agreed to pay for transportation to and from the schools of the Districts and all special routes as defined herein as well as all students requiring transportation for extracurricular activities including activity trips, field trips, and transportation for such events as are required by the Board or its authorized agent from August 1, 2015, through July 31, 2018. The term of this contract may be extended at the option of the District for two (2) additional one (1) year periods. Notice of the extension of the contract shall be provided to the Contractor in writing not later than March 31st of the year of termination.

Local Office and On-Duty Dispatcher/Manager.

The Contractor shall maintain a local bus office parking lot and bus garage within Niles Township or within a ten-mile radius of the intersection of Skokie Boulevard and Oakton Street in Skokie, Illinois. The local office shall be staffed with a manager and at least one dispatcher from 6:00 a.m. to 6:00 p.m. on school days. When buses are in use outside of this time period, a dispatcher or manager will be available by cell phone and pager within five (5) minutes to respond to concerns of the School District.

Indicate the location where the buses will be housed and maintained. The facility must house all functions, including storage of buses, maintenance and dispatch operations of the contractor.

Contract Documents.

The "Contract Documents" shall consist of this Agreement, the Bid Specifications (including but not limited to the Instructions to Bidders, References, all requisite certifications, bid and performance bonds, insurance, and bid form), the Cost Schedule attached as Appendix A. Appendix C and D to this document are merely to assist in the bidding process, and shall not be deemed binding contractual requirements. The Bid Specifications and the Cost Schedule are hereby incorporated into this Agreement as though they were fully set forth herein and shall have the same force and effect as any other provision in this Agreement. In the event of a conflict between the Bid Specifications and this Agreement, the Bid Specifications shall prevail. Upon award of this Contract, the Bid Specifications will be attached hereto as Appendix B, and the Cost Schedule is attached hereto as Appendix A. In attaching, it is the intent of the parties that both appendices are hereby made a part of this Agreement.

Hold Harmless Agreement

The Contractor agrees to indemnify, hold harmless, and defend the Boards of Education of Districts, its officials, employees and agents from and against all suits, actions, legal proceedings, claims, demands, damages, losses, and expenses, including attorneys' fees, in any manner caused by, arising from, incident to, connected with or growing out of the operation of school buses and other vehicles used to transport students under this Contract, in accordance with the liability insurance policies procured by Contractor under this Agreement. Said policies are subject to review and approval by the District.

Document Supremacy

In the event any term or provision of one Contract Document conflicts with a term or provision of another, the term or provision of the Contract shall prevail over all other documents. The terms and provisions of the bid specifications shall prevail over the bid sheet.

Compensation

Contractor shall provide all services as awarded by District and shall be compensated according to the terms of the bid specifications and the Attachments in the amounts listed in the bid sheet submitted by Contractor.

Complete Understanding

This Agreement sets forth all of the promises, agreements, conditions, and understandings between the parties relative to the subject matter hereof, and no other promises, agreements, or understandings, whether oral or written, expressed or implied, exist between the parties.

Amendments

No subsequent alteration, amendment, change, addition, deletion, or modification to this Agreement shall be binding upon the parties hereto unless reduced to writing and duly authorized and signed by each of them.

WHEREAS, the Parties have duly executed and entered into this Contract as of the day and year set forth above.

BOARD OF EDUCATION

FIRST STUDENT, INC.
CONTRACTOR, INC.

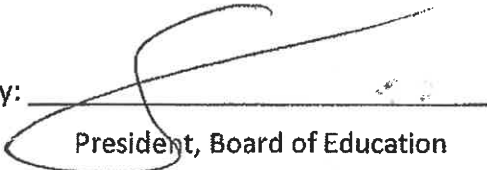
By: 

President, Board of Education

By: 

Authorized Representative

Attest: 

Secretary, Board of Education

Attest: 

Christine Nuccio

Appendix A

Lincolnwood School District #74	2015-16	2016-17	2017-18
AM Rate per Route - Single	\$106.31	\$108.44	\$110.61
AM Rate per Route - Dual	\$53.16	\$54.22	\$55.30
AM Rate per Route - Dual Paired with District 219 \$40 credit back to District 219	\$93.16	\$94.22	\$95.30
PM Rate per Route - Single	\$106.31	\$108.44	\$110.61
PM Rate per Route - Dual	\$53.16	\$54.22	\$55.30
PM Rate per Route - Dual Paired with District 219 \$40 credit back to District 219	\$93.16	\$94.22	\$95.30
Mid-day Rate per Route (Pre-Kindergarten)	\$75.00	\$76.50	\$78.03
Before School Activity Rate per route	\$75.00	\$76.50	\$78.03
After School Activity Rate per Route	\$75.00	\$76.50	\$78.03
Extracurricular Charter Rate per hour	\$50.00	\$51.00	\$52.02

Niles Township High School District 219

Regular Education Only	2015-16	2016-17	2017-18	School Days	Number Routes	2015-16	2016-17	2017-18	Total	
AM Rate per Route - Single	106.31	108.44	110.61	176	25	467,764	477,136	486,684	1,431,584	
AM Rate per Route - Dual (1)	13.16	14.22	15.30	176	24	55,588	60,065	64,627	180,280	
PM Rate per Route - Single	106.31	108.44	110.61	176	27	505,185	515,307	525,619	1,546,111	
PM Rate per Route - Dual (1)	13.16	14.22	15.30	176	13	30,110	32,535	35,006	97,652	
After School Activity Rate per Route(170 DAYS)	75.00	76.50	78.03	170	20	255,000	260,100	265,302	780,402	
Athletic Extracurricular Rate per hour (3 hour minimum) (3)	35.00	35.70	36.41							
Athletic Extracurricular Rate per 5 hour trip, 6 routes/day (3)	175.00	178.50	182.07	170	6	178,500	182,070	185,711	546,281	
Educational Field Trip Extracurricular Rate per Route(3 hour trip) (3)	105.00	107.10	109.24	170	6	107,100	109,242	111,425	327,767	
Field Trip hourly Rate for each hour over 3 hours (3)	35.00	35.70	36.41							
Field Trip/Athletic Surcharge for each mile over 50 miles one-way	0.86	0.88	0.90							
Total District 219										
										4,910,077

Lincroft School District #74	2015-16	2016-17	2017-18	School Days	Number Routes	2015-16	2016-17	2017-18	Total	
AM Rate per Route - Single	106.31	108.44	110.61	176	0	0	0	0	0	
AM Rate per Route - Dual (2)	53.16	54.22	55.30	176	16	149,699	152,684	155,725	458,107	
AM Rate per Route - Dual Paired with District 219 \$40 credit back to District 219	93.16	94.22	95.30	176	8	131,169	132,662	134,182	398,013	
PM Rate per Route - Single	106.31	108.44	110.61	176	0	0	0	0	0	
PM Rate per Route - Dual (2)	53.16	54.22	55.30	176	16	149,699	152,684	155,725	458,107	
PM Rate per Route - Dual Paired with District 219 \$40 credit back to District 219	93.16	94.22	95.30	176	8	131,169	132,662	134,182	398,013	
Mid-day Rate per Route (Pre-kindergarten)	75.00	76.50	78.03	170	2	25,500	26,010	26,530	78,040	
Before School Activity Rate per route	75.00	76.50	78.03	176	4	52,800	53,856	54,933	161,589	
After School Activity Rate per route	75.00	76.50	78.03	170	2	25,500	26,010	26,530	78,040	
Extracurricular Charter Rate per hour	50.00	51.00	52.02	176						
Total District 74										
										2,029,910

Morton Grove School District #70	2015-16	2016-17	2017-18	School Days	Number Routes	2015-16	2016-17	2017-18	Total	
AM Rate per Route - Single	106.31	108.44	110.61	176	0	0	0	0	0	
AM Rate per Route - Dual Paired with District 219 \$40 credit back to District 219	93.16	94.22	95.30	176	11	180,358	182,410	184,501	547,268	
PM Rate per Route - Single	106.31	108.44	110.61	176	8	149,684	152,684	155,739	458,107	
PM Rate per Route - Single using District 219 equipment \$40 credit back to District 219	146.31	148.44	150.61	176	3	77,252	78,376	79,522	235,150	
Mid-day Rate per Route using District 219 equipment \$10 credit back to District 219	85.00	86.50	88.03	176	2	29,920	30,448	30,987	91,355	
Extracurricular Charter Rate per hour	50.00	51.00	52.02	176						
Total Districts 70										
										1,331,880
Niles School District #71	2015-16	2016-17	2017-18	School Days	Number Routes	2015-16	2016-17	2017-18	Total	
AM Rate per Route - Single	106.31	108.44	110.61	176	0	0	0	0	0	
AM Rate per Route - Dual Paired with District 219 \$40 credit back to District 219	93.16	94.22	95.30	176	5	81,981	82,914	83,864	248,758	
PM Rate per Route - Single	106.31	108.44	110.61	176	0	0	0	0	0	
PM Rate per Route - Dual Paired with District 219 \$40 credit back to District 219	93.16	94.22	95.30	176	5	81,981	82,914	83,864	248,758	
After School Activity Rate per Route using District 219 equipment \$10 credit back to District 219	85.00	86.50	88.03	144	1	12,240	12,456	12,676	37,372	
Extracurricular Charter Rate per hour	50.00	51.00	52.02	176						
Total Districts 71										
										534,889

(1) Assumes route bus transports one high school route and one elementary school route per am or pm dispatch.

(2) Assumes two individual elementary routes share the same routed bus and results in two separate charges per am or pm dispatch.

(3) Assumes trip is operated with District 219 bus. In the event a First Student bus is used, then the rate becomes \$50 per hour in year one (1)

Total Bid

8,806,756

**NILES TOWNSHIP HIGH SCHOOL DISTRICT 219, MORTON GROVE SCHOOL DISTRICT 70,
NILES SCHOOL DISTRICT 71, AND LINCOLNWOOD SCHOOL DISTRICT 74**

SPECIFICATIONS FOR STUDENT BUS TRANSPORTATION

BID OPENING DATE: MARCH 16, 2015 2:00 P.M.

INSTRUCTIONS TO BIDDERS:

1. NOTICE IS HEREBY GIVEN that proposals for a three (3) year contract for general education transportation services for Niles Township High School District 219, Morton Grove School District 70, Niles School District 71, and Lincolnwood School District 74 (collectively, "Districts") will be opened and read in the Niles Township High School District Administrative Office located at 7700 Gross Point Road (Board Room), Skokie, Illinois 60077, at the time and date indicated above. The contract period, if awarded, will be for the school years 2015-2016, 2016-2017, and 2017-2018 with extensions to be allowed as provided under Illinois School Code. The contract will start on August 1, 2015.

2. Questions and Clarifications: Bidders must satisfy themselves, upon examination of the specifications, of the intent of the specifications. Any questions, discrepancies, omissions, ambiguities or conflicts in the contract documents should be in writing and brought to the attention of Mr. Eric Trimberger, Assistant Superintendent for Business/CSBO, at eritri@d219.org.

3. The sealed proposals shall be delivered to Mr. Eric Trimberger, Assistant Superintendent for Business/CSBO at Niles Township High School District 219, 7700 Gross Point Road, Skokie 60077 at any time prior to but not later than 2:00 P.M. local time on March 16, 2015. The Districts do not accept responsibility for delays in transmittal and must have actually received at the bid proposal in advance of the time set forth above in order for the bid to be deemed received.

4. Each proposal must be submitted on the bid form provided with these specifications. For purposes of clarification, a dual route should be considered as either an AM route that can be covered with the same equipment as another AM a route that same day or a PM route that can be covered with the same equipment as another PM route that same day. For example, if a bus can run an 8:30 a.m. route for a particular District and then run a 9:30 a.m. route for either the same or another District, than both routes would be priced as a dual route rather than a single route.

5. Bids must be contained in a sealed envelope, which shall be endorsed on the outside thereof with the following information:

PROPOSAL FOR STUDENT BUS TRANSPORTATION

Name and Address of Bidder

6. All Bids submitted must be valid and held open for a minimum period of ninety (90) days after the date set for the bid opening.
7. The Districts reserve the right to reject any or all bids for any reason, or to waive any informalities, irregularities or defects in any proposal, should it deem to be in their best interest to do so.
8. The Districts intend to award separate contracts to the same company best able to provide the most efficient and cost effective services for all Districts.
9. All figures given for passengers, routes, or lengths of routes are based on estimates from the present operation.
10. Bidders shall not include taxes, which school districts are not subject to, in their quotation.
11. All bids shall be deemed final, conclusive and irrevocable and no bid shall be subject to correction or amendment for any error or miscalculation.
12. Bids received after the time specified in the invitation to bid will not be considered. The method of transmittal of the bid proposal is at bidder's risk of untimely receipt.
13. A bid bond for 10% of the value of the bid for the first year of the contract shall accompany all bids submitted. A bid bond shall be in the form of a certified check made payable to Niles Township High School District 219 or a bond issued by an insurance company licensed to do business in the State of Illinois with a rating of at least "A" from AM Best. However, the Districts will require, from the successful contractor, an individual performance bond covering each year of the contract in the amount of 100% of the yearly cost. The performance bond will be held by Niles Township High School District 219 on behalf of the Districts. Each bid must indicate the additional cost of such Bond. Each bid must be accompanied by a letter from an insurance company licensed in the State of Illinois with a Best Insurance Rating of at least A-10 indicating that the company will provide the specified performance bond for the bidder if desired.
14. The Districts may inquire as to the financial stability of the bidder and may request financial references.
15. The bidder shall at all times observe and comply with all laws, ordinances, regulations and codes of the federal, state, county and other local government agencies, which may in any manner affect the performance of the contract, and in particular all such laws pertaining to prevailing wage, equal opportunity, OSHA, consumer report safety act and safety. The contractor, in performing under this contract, shall not discriminate against any worker, employee or applicant, or any member of the public because of race, religion, color, age, marital status, sex, national origin, ancestry, or physical or mental disability, or engage in any other means of unlawful discrimination.

Contractor shall comply with all laws and regulations pertaining to Equal Opportunity and Fair Employment Practices including the Illinois Human Rights Act. Contractor shall not discriminate against any worker, employee, or rider or any other member of the public because of race, religion, age, color, sex, disability, marital status, sexual preference, national origin, unsatisfactory military discharge nor otherwise commit an unfair labor practice. Contractor further agrees that this article will be incorporated by Contractor in all contracts entered into with suppliers of materials and services, subcontractors and at labor organizations, furnishing skilled or unskilled labor or may perform any such labor or service.

16. Bidder must use the included Bid Proposal Forms when submitting bid, providing all information as requested. All prices must be typed or written in ink on the enclosed Bid Proposal Forms.

If mistakes are found in multiplication or addition of unit prices against total prices, the unit price shall govern for all purposes.

17. To the fullest extent permitted by law, Contractor agrees to indemnify, hold harmless and defend the Districts and their respective members, officers, employees, students, teachers, and agents against all suits, actions, legal proceedings, claims and demands, and against all damage, liabilities, judgments, lost cost, expense and attorney's fees, in any manner caused by, arising from, incident to, connected with or growing out of the provision of services under this contract.

18. No contract shall be assigned or any part of the same subcontracted without the consent of the Districts, but in no case shall such consent relieve the contractor from his obligations, or change the terms of the contract.

19. In determining the successful bidder, the Districts will consider the following:

- i. The safety and comfort of the students including demonstration of the ability of parents and students to track buses on an existing account
- ii. Bid Price
- iii. Financial stability of the bidder
- iv. Adherence to transportation specification requirements
- v. References and experience in school district transportation

20. Execution of Contract – The successful bidder will be required to execute separate transportation contracts with the Districts in substantially the same form as set forth in these Specifications.

21. The bid shall be based on the premise that neither the Cooperative / Districts shall be responsible for financing, holding title, purchasing, maintaining, repairing, or licensing of vehicles.

22. The contractor shall own all buses or vehicles placed in operation by the contractor under this contract for routes that are not paired with District 219 and shall be responsible for their maintenance and repair. The contractor will provide the maintenance and repair of buses purchased by District 219.
23. The Districts shall have first priority for the use of the buses of the contractor required to perform the services pursuant to the Agreement. The contractor may use buses for charters and bus sharing operations provided these operations have no negative effect on the Daily student transportation or the right of first priority for the use of the buses.
24. The Contractor must provide route maps for a.m. and p.m. routes. The route maps will show the routes for each District. The route maps will also show which Districts will be paired together in terms of sharing buses and sharing routes. The route maps will also provide for the specific number of buses to be committed to each route, and which Districts will be served by said bus/route/pairing. For instance, if the high school requires 22 routes for its morning transportation to school, the route map will show how many buses will serve those 22 routes, which Districts are paired with those 22 routes, and how the pairing will be applied.

GENERAL CONDITIONS

SCOPE

The successful Contractor shall, during the period set forth, provide and maintain the required number of school buses to transport conveniently and safely any and all students designated by the Districts to be served under the provisions of this proposal. Such transportation shall be provided for each and every day that school is in session, for each and every Districts that is a party to this contract, including to and from each and every Districts in the morning and afternoon, as well as mid-day transportation needs (including between buildings, between separate districts and cooperatives, and any other mid-day needs), and extra-curricular and activity-related transportation needs, and in accordance with bus routes and schedules agreed upon by the parties.

The Districts reserve the right to revise or change any and all routes and the number of buses required to best suit their needs at any time before or during the school year. However, any changes or revisions to routes will be made in compliance with this Contract, bearing in mind that services are shared, and changes made may affect service to other Districts that are parties to this Contract. To that end, the Districts will work together to minimize changes that could negatively impact services to the other Districts.

The Districts reserve the right to contract with other contractors for extra-curricular, charter, and other trips, in addition to the services provided by this Contract, if it meets their financial interests to do so. This would include school bus, motor coach, van, or other types of transportation needs.

The annual letter that goes home to the parents of all eligible bus riders will include the name and phone number of the contractor along with instructions that the Contractor should be called if they have questions or need assistance. In addition, the schools will often refer calls to the contractor.

All expenses related to the operation of the fleet of the Contractor shall be paid by the contractor.

The Scope of this Bid is set forth in greater detail in the proposed contract, attached to these Instructions to Bidders.

REFERENCES

As indicated above, the Districts are concerned with both the financial responsibilities of the bidder and the proven ability to satisfactorily perform the contract. Written responses must be provided within the bid for the following areas of concern:

1. Indicate management experience in bus operation and transporting students. The successful bidder must have at least three (3) years of experience providing transportation services of similar size and scope to this contract.
2. Provide the names of all public school districts for whom your company currently provides transportation or has provided transportation within the previous 10 years in the following counties: Cook, DuPage, Kane, Lake, McHenry and Will. Provide the point of contact and phone number for whoever served as the district point of contact for the transportation contract. If you no longer provide transportation services for the school district, please explain why you do not. Responses are to include any contracts that you defaulted on or were cancelled by either you or the school district. Provide three letters of recommendation from current or previous clients with your bid submission.
3. Indicate all Illinois litigation your firm has been involved with during the last 10 years.

LOCAL OFFICE

The Districts will provide the Contractor with a local bus office, parking lot and bus garage within Niles Township. In the event that the Districts need to construct a bus garage, the Contractor will need to provide access to their own facility for maintenance until construction of the bus garage is complete. The contractor shall staff the office with a manager and at least one lead dispatcher from 6:00 a.m. to 6:00 p.m. on school days. When buses are in use outside of this time period, a dispatcher or manager will be available by cell phone and pager within five (5) minutes to respond to concerns of the School District.

Bidders are instructed to furnish resumes including the address and telephone number of the proposed terminal manager, lead dispatcher, and head mechanic for the service of this contract. Also include the location of towing and emergency services vehicles to be used in the service of this contract. The Districts reserve the right to interview the proposed terminal manager prior to the award of contract. The proposed terminal manager must have at least five years of experience operating a terminal of similar size and scope required to service this bid.

The contractor agrees that each morning before any school buses are used for transportation; the driver shall inspect same carefully for defects, and remedy any defects before using said vehicles.

BUS DRIVERS

The Contractor shall provide only bus drivers who do meet or exceed State of Illinois laws and regulations related to public school transportation and have valid licenses permitting them to serve as school bus drivers. The Contractor will provide a roster of drivers for approval by the School District prior to the first day of each school year and on a monthly basis thereafter for all new drivers, including:

1. Driver's name;
2. Driver's social security number;
3. Driver's commercial driver's license number and permit number;
4. The date on which the driver successfully passed a drug and alcohol screening; and
5. The date on which the driver was cleared by a criminal background check.

All employees of Contractor will submit to a criminal background check conducted by Districts before performing work covered by this contract. The cost of these background checks will be paid by Contractor.

All Drivers employed by the Contractor will undergo drug/alcohol testing prior to driving students.

Drivers who have not submitted to the background check and drug/alcohol testing or those who have not been cleared by a background check and drug/alcohol test may not be employed under this Contract nor shall they render services.

The parties hereby agree that the Superintendent of Schools or the Superintendent's designee may reasonably remove a particular bus driver from a particular bus route or from all buses servicing the Districts, so long as, if such removal affects a bus route pairing, all Districts affected are in agreement. In order to effectuate such removal, the Superintendent or his/her designee will make a reasonable request to the Contractor, and such Contractor will remove the bus driver within 24

hours of the request being made the Contractor agrees that this power of removal in no way is to be construed as making the bus driver or the bus company an employee, agent, servant or co-employee of the Board.

Payment to Contractor.

The Districts shall pay in accordance with Appendix A. Specifically, each School District party to this agreement will be charged for the services rendered to it, on a per route basis. Where /School Districts are “paired” on routes, the cost will be prorated by the number of students attributable to each School District on the route. All payments made to the Contractor must be approved by each Board of Education prior to payment; accordingly, all payments will be made within ten days of the Board of Education meeting at which the invoice is presented for payment. Invoices will be presented to the Board of Education at its meeting immediately following. If the Board of Education does not receive an invoice 15 business days in advance of its next meeting, the invoice will not be presented to the Board of Education until the following meeting.

Billing for activities, extra-curricular, field trips, intra-district trips, shuttle and special routes, and late runs shall be invoiced separately from regular morning and afternoon bus route invoices.

Invoices shall be calculated in accordance with the rates shown on the Appendix A.

Should any School District fail to make its payment in a timely fashion, such failure shall not affect the services to be rendered under this contract. The Contractor has the right to enforce collection proceedings as to any School District that fails to make its payments, while continuing to provide the transportation services called for by this Contract. Only where a majority of the School District parties fail to make payment may the Contractor discontinue services to those individual School District parties, and re-configure routes for those remaining School District parties.

The payment amounts set forth in this Contract shall remain in effect until August 1, 2018. For subsequent contract years, both the Contractor and the School Districts shall enter into negotiations at least ninety (90) days prior to the end of the current school year to mutually agree to changes in price for the various services performed under the contract. The Contractor agrees that the unit prices shall not increase by more than the increases in the Consumer Price Index for Urban Consumers (CPI-U). For the renewal year of August 1, 2018 to July 31, 2019, the CPI-U used for the maximum renewal will be CPI-U for December of 2016 that is published in January, 2017. For the renewal year of August 1, 2019 to July 31, 2020, the CPI-U used for the maximum renewal will be the CPI-U for December of 2017 that is published in January of 2018.

FUEL ESCALATOR

The successful bidder shall purchase and provide all necessary motor fuels for the performance of the contract. There shall be NO negotiations or changes in the bid language for the entire first year of the contract (2015-2016) for a Fuel Escalator Clause. Bidders are to use \$2 per gallon for the purposes of pricing diesel for Years 2 and 3 of the contract. In the event that diesel fuel exceeds \$2 per gallon, the contractor may assess an additional cost to the Districts upon providing invoices that indicate pricing above \$2 per gallon. Fuel escalator assessments are limited to three (3) gallons per route. District 219 will provide a propane fuel dispenser and pay for propane used for District 219 routes and routes paired with District 219.

EQUIPMENT

- a. Contractor agrees that all equipment used during the life of this contract shall conform to all local, state and federal statutes pertaining to school bus transportation, vehicle specifications and safety, and to all relevant state and federal regulations. All buses shall be equipped with all safety equipment mandated by the federal government and/or the State of Illinois, including push out windows, rear exit doors and crossing control arms. If any bus equipment owned by the contractor fails at any time to so comply in whole or in part during the term of the contract, it shall be replaced by the contractor without expense to the Districts and without claims for adjustment per diem, or per trip, compensation. No substitution of unauthorized conveyances will be allowed, except in cases of an emergency, after authorization by the Districts.
- b. The contractor agrees that each morning before any school buses are used for transportation; the driver shall inspect same carefully for defects, and remedy any defects before using said vehicles.
- c. District 219 will purchase 55 propane fueled buses to service District 219 routes and elementary routes paired with District 219 routes. Bidders are to operate and perform maintenance on District 219 owned equipment. Bidders will insure District 219 owned equipment. Contractor will provide diesel fueled buses for routes that are not paired with District 219 (8 AM/PM routes in District 74 and 11 PM routes in District 70). Contractor will charge elementary districts using District 219 owned equipment the same price for dual routes using bidder owned equipment. The difference in the price charged for bidder owned equipment and District 219 owned equipment is to be credited to District 219.
- d. District 219 owned equipment may not be paired with other school districts outside of this contract without written approval from District 219. District 219 owns first division vehicles and provides any transportation needed with those vehicles outside of this contract. Contractor agrees that no contractor owned vehicles used to service Districts will be more than 120 months old. Contractor also agrees that at no time during this three-year (3) contract (or the potential extension) will the average age of the contractor owned vehicles used for Districts exceed eighty four (84) months. If Contractor does not have adequate equipment at the time of award of the contract, Contractor shall provide a certified statement from an authorized dealer, manufacturer, or other reliable source, showing that all necessary equipment will be supplied, and that all such equipment will be available on site for use by Contractor for performance of the contract no later than April 10, 2015. All full sized school buses will be defined as being at least 71 passengers in capacity unless otherwise defined and mutually agreed upon by Districts and Contractor.
- e. Contractor agrees to obtain in timely fashion all required inspections and to provide a copy of the inspection report for each vehicle seven (7) days prior to the first day of transportation.
- f. Contractor agrees that each driver will be equipped with a two-way communication device for emergency purposes only. Drivers are not to use the communication device for any purpose, even hands-free mode, while driving. Bidders are to describe how they will meet

this requirement. Each bus will be equipped with first-aid kit, individual seat belts, padded seats, stop-arms, school bus flashers, emergency exit, reinforced roof, safety-glass windows, and clearly visible markings as a school bus.

- g. Each bus will be equipped with first-aid kit, individual lap seat belts (for buses that service Districts 70, 71, and 74) padded seats, stop-arms, school bus flashers, emergency exit, reinforced roof, safety-glass windows, and clearly visible markings as a school bus.
- h. Each school bus will be furnished with hardware and software to fully utilize and implement GPS and a Zonar Student Transportation Tracking System or equivalent that is acceptable to the Districts. An application that tracks bus locations with a mobile device or computer will be provided to parents at no additional cost. Bidder must be currently using their proposed system in at least one school district located in Cook, DuPage, Kane, Lake, or Will County. Bidders are to describe how they will meet this requirement including where it is currently being used. Acceptance of the proposed GPS/Student Tracker system/application is at the sole discretion of the Districts. District reserve the right to a site visit to see the proposed system in operation. The proposed system must be in place and operating for Districts no later than July 1, 2015. Contractor will be assessed a penalty of \$500/day for each day that an application is not available for parents beginning with the start of the school year for District 219 in August, 2015.
- i. Contractor agrees that the maximum number of persons that Contractor will permit to occupy any vehicle is the seating capacity established by the vehicle manufacturer.
- j. Contractor agrees to make available a sufficient number and variety of vehicles equipped to provide safe and convenient transportation for all assigned students.
- k. Contractor agrees that each vehicle will be maintained in: (1) a clean, sanitary condition, and (2) good mechanical condition, including the tires. Districts reserve the right to inspect any and all buses to ensure compliance.
- l. Contractor agrees that any and all vandalism damages to Contractor's equipment shall be the responsibility of the Contractor. Districts agree(s) to cooperate with the Contractor in reasonably attempting to recoup damages from responsible parties.
- m. Contractor agrees to provide one standby vehicle for every ten active vehicles to ensure uninterrupted service in the event of mechanical breakdown of a vehicle. There must be a similar sized or larger capacity standby vehicle available. In the event the Contractor does not have sufficient standby vehicles to serve the District's needs, liquidated damages of \$1,000 per day per vehicle that was lacking will be imposed. Contractor must submit proof of this requirement at the start of each contract year and as requested by Districts. Detailed information including but not limited to the
 - 1. vehicle identification number;
 - 2. date manufactured;
 - 3. name of chassis manufacturer;
 - 4. vehicle capacity;
 - 5. body manufacturer;
 - 6. current mileage;

7. location where the vehicles will be maintained and parked when not in use during the term of the contract;

The date of the last safety inspection for each bus proposed for service of this contract must be submitted to support this requirement.

- n. Contractor agrees to equip and maintain all standby vehicles as described herein.
- o. Contractor agrees to equip all buses with route numbers that are to be displayed in the right front side window of each vehicle, in bold numerals, each numeral no less than six inches in height, or clearly visible material.
- p. Contractor agrees to equip all buses that transport students of Districts with a DVR box or similar recording mechanism in which a video camera will be mounted and operated. All recorded material shall be the sole and exclusive property of the School District, the contractor shall have no right to retain, view or otherwise make use of any tape without the written approval of the School District. Every bus used in this contract is to have a working camera installed at all times. Bidders are to describe the camera system they are proposing.

Video recordings must be turned over to the requesting school in electronic format (flash drive or CD) within 24 hours of the request. Review of the video recordings and discipline for bus misconduct as revealed by the tapes shall be the responsibility of Districts.
- q. All buses shall be equipped with two-way radios that will be active at all times. These radios must have a capacity sufficient to maintain contact with the terminal at all route points and a person must be available at the terminal to respond at all times while routes are being run. An adequate number of spare radios must be available so that no bus is ever without a working radio while transporting students. The Contractor shall be able to supply 7 hand-held radios if requested for each school (as requested District 219 2, District 70 1, District 71 1 and, District 74 3) with the frequency of the buses assigned to the District for direct communication between the school and the buses. If additional radios are requested, the expense is to be paid by the District requesting the radio. Such radios shall be used in accordance with all existing FCC regulations and/or licensing requirements.
- p. Contractor shall either own and maintain sufficient tow vehicles and other emergency equipment or maintain a contact to provide sufficient and immediate emergency service to all vehicles used in the performance of this contract.
- q. In the event of a breakdown or emergency, standby buses in good working condition must be maintained and available in sufficient numbers and used in the event any buses regularly transporting students shall be inoperable. Standby buses shall meet the same standards as regular route vehicles. Daily use of spare buses will not be allowed to exceed 10% of the number of vehicles required to service the contract. A minimum of one standby vehicle for every ten (10) regular vehicles shall be available.
- r. Bidder is to describe their routing software used to determine the most efficient route structure. Routes are to be redone annually and as requested by the Districts.

INSURANCE

The Contractor agrees that neither the Boards nor their members, officials, employees and agents shall in any way or manner be answerable to or suffer loss or damages, expenses, or liabilities for any acts occasioned by the Contractor, his employees, agents, or servants. The Contractor assumes all liabilities of any kind or nature arising from the operation of this Contract either by accident, negligence, theft, or otherwise.

The Contractor agrees to indemnify and hold harmless the Boards and their officials, members, employees and agents for any liability and/or claim brought against any of them as a result of Contractor's performance under this Contract.

Contractor shall procure and maintain the following minimum insurance coverages, provided that in the event the State of Illinois requires additional forms of coverage or coverage in greater amounts than those set forth herein, the Contractor shall comply with all such State requirements.

- a. Comprehensive General Liability/Contractual Personal Injury/Employer's Liability
\$1,000,000 per occurrence/\$3,000,000 aggregate
- b. Automobile Comprehensive Liability
\$2,000,000 combined single limit
- c. Medical Payment/all Vehicles
\$5,000 per person each occurrence
- d. Excess Umbrella
\$15,000,000 each occurrence, \$15,000,000 general aggregate
- e. Uninsured and Underinsured Motorist
\$1,000,000/\$1,000,000 combined single limit
- f. Worker's Compensation insurance shall be at least the minimum of \$1,000,000 each occurrence.
- g. Insurance shall be with companies licensed to do business in Illinois with an AM Best rating of at least A 7. Insurance coverage cannot be terminated or non-renewed without thirty (30) days written notice to the School District by the insurance company. A successor company must be in place at the time of such notice.
- h. Contractor shall provide the Superintendent/Business Manager of each School District with a Certificate of Insurance no later than June 15th annually for the life of the contract. The certificate of insurance shall provide that the insurance shall not be cancelled, non-renewed or modified without the School District's receipt of written notice of said action not less than thirty (30) days prior to termination of coverage. The School District requires that the parties indemnified in the next paragraph, subparagraph "i", be named as additional insured and/or that the Contractor carry contractual liability coverage as part of a comprehensive general liability in amounts equivalent to the amounts set forth in subparagraph "a".
- i. Contractor expressly understands and agrees that any performance bond or insurance protection required by this contract, or otherwise provided by Contractor shall in no way

limit Contractor's responsibility to indemnify, hold harmless and defend the Indemnity herein provided.

- j. Within seven (7) business days following the effective date of this Contract, Contractor shall provide School District with a Performance Bond, which shall guarantee the Contractor's performance of the duties imposed upon it pursuant to the contract and indemnify School District, its Board of Education, Board members, officers, employees, and agents from any loss resulting from failure of Contractor to fully perform each or all of said duties for the enforceable duration of this Agreement.
- k. The contractor shall present all certificates of insurance to the Districts within thirty (30) days of the effective date of this contract and maintain current certificates of insurance throughout the term of this contract.
- l. All policies of insurance shall carry an endorsement to the effect that they cannot be modified, canceled or non-renewed without thirty (30) days written notice by certified or registered mail. Cancellation of any of the insurance policies required above, or the reduction of the amounts of liability insurance or medical coverage provided by such policies, shall be deemed a material breach of the contract and shall be cause for termination of the contract. Upon receipt of a notice of cancellation of any of the aforesaid insurance policies, or a reduction in the amount of coverage, the Districts shall have the option of terminating the contract or paying the premiums necessary to continue the insurance policy at the required limits of liability and deduct the payment or payments from the compensation due the contractor under the contract. No policy shall reserve or permit any right of subrogation against the Districts, their officers, employees, students, and agents thereof.
- m. Any policy under this paragraph shall cover the transportation of pupils, their parents or guardians, authorized chaperones, school district officers, faculty and employees and school nurses to and from any school or school district and in connection with an extracurricular school activity authorized by and made in compliance with school policy and Illinois State School Code.

OPERATION PLAN

- a. Eligible Students.
Any student who is a resident of the School District who is approved for transportation by the District administration will be transported by the Contractor.
- b. No Unauthorized Persons.
No unauthorized persons shall be allowed in any vehicle while engaged in transporting students; however, the School District reserves the right to have an authorized employee ride on any vehicle on the contracted route, without prior notice to the Contractor. It is the driver's responsibility to check that each passenger has a valid School District bus pass.
- c. School Calendar.
All transportation will be in accordance with the School District calendar including provisions for scheduled days off, examination schedules, testing schedules, early

dismissal days and beginning and ending times for the school day. The School District shall, by July 1 of each contract year, furnish Contractor with the School calendar and, subsequently, notice of any changes shall be furnished to the Contractor in a timely fashion.

d. Establishment of Routes.

1. The Contractor agrees to provide typed tentative routes to the School District no later than the first week of August for the transportation of students, and revised typed "final" routes are to be furnished to the School District by September 15 of each year for the regular school year. Typed routes shall include a route number, bus number, driver's name, estimated pick-up and drop-off times and corresponding locations, plus other information as may be requested by the Superintendent/Business Manager.
2. Once the Contractor's operation plan (routes) has been fully approved, it may not be changed by the Contractor without the consent of the School District. Changes may be agreed to via telephone, but must be confirmed within five (5) days in writing. The School District may require route changes based upon student population demographics.
3. The bus driver shall not deviate from the normal pickup route or from the normal pickup route time schedule except for reasons beyond his/her control; such deviations shall be reported to the Contractor who, in turn, shall promptly report the same to the District's Superintendent/Business Manager.
4. District 219 retains the right to specify the type of vehicle used on all routes. Additionally, District 219 retains the right to assign individual students to an alternate transportation service when the need arises.

ROUTES

a. Routes Definition.

For purposes of Districts a route will be defined as use of a school bus for morning pick-up and afternoon drop-off. Buses will arrive at school in the morning between 10-20 minutes of scheduled start times. Failure to do so will result in a penalty in the amount of \$150 per day per route for routes that are 10 to 29 minutes late, and \$250 for routes that are 30 or more minutes late. The penalties will be imposed on the Contractor and deducted from the next payment from the Districts. Buses will arrive at school no later than dismissal time in the afternoon. Failure to do so will result in a penalty in the amount of \$150 per day per route routes that are 10 to 29 minutes late, and \$250 for routes that are 30 or more minutes late. The penalties will be imposed on the Contractor and deducted from the next payment from the Districts. Should the buses be late, the Contractor should notify the Superintendent or Business Manager of the reason for the delay, and the timeframe in which to expect the buses, as soon as practicable, but within 1 hour of becoming aware of the problem. For further detail on the imposition of penalties, please see Letter (f) of "General Requirements."

Should the Contractor failure to abide by established timelines more than twice per month, or fail to ever notify the Superintendent of any delays, such conduct will be deemed to be a breach of contract.

No regular school day route may extend beyond forty (40) minutes in length. These routes will be on a regular school day basis with modifications mutually agreed to on special situations as dictated by weather conditions, testing schedules and/or late start school days.

1. To/From School Routes.

Contractor shall provide bus service for each school route as designated by each School District's Superintendent/Business Manager. Within the route, stops shall be so spaced so that the distance of travel from a student's home to a bus stop shall not be greater than three (3) blocks. Routes should be established so that no student need cross an arterial street or main thoroughfare to either reach a bus stop or reach their home after being dropped off. Any pairing of routes should be for the purpose of better serving all Districts and accommodating time frames; any pairing of routes requires the approval of District 219.

2. Extra Curricular Sports Buses at the Conclusion of the Regular School Day.

Niles Township High School District 219 needs to have available on a regular daily basis three (3) school buses at each high school for the purpose of transporting sports teams to different events. These buses need to be available at dismissal time at each school, ready to leave with the sports team to wherever the competition is being held. These buses need to be available on a daily basis. On days that the buses are not going to be utilized, District 219 will notify the Contractor at least 48 hours in advance and the District will not be charged. Billing for these trips will be as delineated in Appendix A. Bus drivers are expected to remain at the site of the sport competition for the duration of the contest and make the sponsor or coach of the team aware of how to contact them.

The other School District parties to this contract may need regular extra-curricular transportation, as described in greater detail on the list of proposed transportation needs, attached hereto as Appendix B.

3. After School Activity Routes.

Niles Township High School District 219 requires five buses at each school every school day. These buses will leave the schools with students involved in after school activities at approximately 5:00 p.m. and 6:00 p.m.

On the days that the School District notifies the Contractor, at least one week in advance that the routes will not be needed, no charge will be assessed.

The other School District parties to this contract may need regular extra-curricular transportation, as described in greater detail on Appendix B.

4. Seating Capacity.

- i. For school routes, seating may be at two (2) students per standard seat. "Standard seat" is defined as the common size of a seat on a full-sized school bus, as defined in the "Instructions to Bidders."
- ii. For school field trips and extracurricular trips, seating shall be at not more than two (2) students per standard seat.

b. Ridership Audit.

Contractor shall submit to the School District, on an "as requested" basis, a Ridership Report covering one week for each To and From school route to each school building. This headcount may also be required for the after school activity routes. The report shall indicate the seating capacity (at 2 per seat) of the vehicle serving the route, the number of students entering the vehicle at each pick-up point for each route. The Contractor shall make suggestions on a monthly basis as to how to attain route efficiencies or better serve the School District. The purpose of Ridership Audits is to ensure that routes are efficiently loaded and to provide data on which to base decisions regarding route removal, combination and expansion.

c. Route Times.

The starting time for incoming routes shall be set to allow the bus to arrive at the school not less than ten minutes or more than 20 minutes prior to the designated start time of the school. Outgoing routes shall be scheduled so that the bus arrives at the school five minutes prior to dismissal.

District 219's start time will be contingent upon the start/dismissal time negotiated in its collective bargaining agreement with its teachers.

Student start times for all other cooperatives/districts are attached hereto as Appendix D. Should any district vary its student start/dismissal time from that listed on Appendix D, it must do so in cooperation with and agreement by all other parties to this Agreement. Should it change its student start/dismissal time without obtaining the agreement of the other parties, it will be liable for any and all damages incurred.

d. Field Trips – Extra Curricular Trips.

The School Districts shall schedule at least one (1) faculty member or other approved adult supervisor on each Field Trip or Extra Curricular bus.

1. Scheduling: Field trips shall be scheduled by the school requiring the trip at least ten (10) days in advance of the field trip. Generally, field trips scheduled in this manner shall be billed as delineated Appendix A. Field trips shall be scheduled through each School District's form "Vehicle Use Trip Requisition". This form shall be completed by Contractor and returned to the ordering school upon completion of the trip. Both parties will endeavor to simplify this process as time permits.
2. Cancellations: Field trips may be canceled by the ordering school at no charge to the school when the cancellation occurs not less than three (3) days prior to the field trip.

3. Field Trips Schedules Less than Five (5) School Days in Advance: Contractor shall not be required to provide a driver at straight time. However, where such a trip is expected to require overtime for drivers, Contractor shall inform the ordering school upon receipt of the Vehicle Use Trip Requisition. The school shall then have the option of accepting the field trip at the overtime rate or canceling the trip.

e. Individual District Regular Routes.

Signs are to be placed on all individual school buses identifying the school and route. Please see Appendix C for information related to the regular routes.

f. Routes are paired and to bid as follows:

Niles North A.M. is paired with District 70 A.M. (11 routes).

Niles North P.M. is not to be paired.

Niles West A.M. is paired with District 71 (5), and District 74 Rutledge (8) routes (13 routes total).

Niles West P.M. is paired with District 71 (5) and District 74 Todd Hall routes (8) (13 routes total).

District 74 A.M. Lincoln Hall is paired with Todd Hall 8 double run routes total.

District 74 PM Routes Rutledge Hall is paired with Lincoln Hall 8 double run routes total

- g. Niles North and Niles West have some routes that are repeated. Actual routes were provided at the pre-bid meeting. For example, Niles North morning routes 15 and 19 currently use 2 buses. Contractor will separate these extra buses into separate routes at the start of the contract. In the afternoon, Niles North has 2 "E", 3 "K",
- h. Bidders are to bid on 176 days of service. This is the minimum guarantee. Each school district sets their own calendar and reserves the right to add additional days of service beyond 176.
- i. District 219 operates 30 days of summer school. Starting in the Summer of 2016, programming will offered at both high schools. Regular education routes will be similar to the current year; however, the actual number of routes will be less.
- j. The District 219 6 dedicated daily Athletic buses are to be billed at an hourly rate. These routes conflict with PM routes. Bidders are to provide an hourly rate for these trips. For the purposes of the bid tabulation, 6 routes per day, 170days, 5 hours per trip is the factor to calculate estimated annual costs. The minimum guarantee for each athletic route is 3 hours. Bidders are reminded that these routes can be cancelled with one week's notice.
- k. On the bid form, District 219 is not guaranteeing 3 field trips per day. Approximately \$151,000 was spent on field trips last year. This line item is to solicit pricing on an hourly rate per trip (3 hour minimum) basis and each trip is to be billed individually.
- l. Bidders are to provide a surcharge rate per mile for trips that are over 50 miles one-way.

- m. First Division Vehicles are operated by District 219. Bidders will not be providing this service. District 219 reserves the right to perform all service not expressly guaranteed as minimum service level on the bid form.

STUDENT BEHAVIOR

- a. The School District, through its building principals, may from time to time, issue instructions governing the behavior of students. The Contractor's drivers shall, to the best of their abilities, follow such instructions at all times. Such instructions shall also include procedures for reporting misconduct.
- b. The Contractor will report each incident of student misconduct immediately by phone or in person to the Dean of Students of the receiving school, and follow up with a written report.
- c. The Contractor will not permit smoking, the consumption of alcohol or the consumption of non-prescription drugs controlled substances, and/or engage in immoral activities on the bus.
- d. The Contractor shall promptly notify the Dean of Students whenever any student is recommended for suspension from transportation. The Dean of Students shall make a final determination of suspension from transportation.
- e. The Contractor's drivers shall not administer physical punishment to any student on the bus.
- f. No vehicle shall transport more than five (5) students in wheelchairs in each bus route, unless prior District approval is obtained.
- g. The contractor shall be responsible for informing all parents of scheduled home pickup and return times, and shall maintain a consistent schedule in this regard.
- h. General Education students are picked up and dropped off at District agreed upon locations.
- i. No unauthorized persons shall be allowed in any vehicle while engaged in transporting students; however, the Districts reserve the right to have an authorized representative ride on any bus, on any contracted route, without prior notice to the carrier. Drivers will not be allowed to bring their children on their runs.
- j. No student will be transferred from one vehicle to another vehicle while en-route to or from school without the expressed prior approval of the District.
- k. The Contractor understands that some of the students to be transported suffer from behavioral disorders and may present discipline problems. The School Districts have statutory obligations to provide transportation for all students, regardless of their behavior. The Contractor will undertake to transport all students taking into consideration that some of the students may not meet the expectations of acceptable conduct for the typical student. No student can be refused transportation due to discipline or conduct problems. If a student exhibits inappropriate behavior, this conduct shall be brought to the attention of the appropriate school official who shall determine what (if any) disciplinary action is required. Severe conduct problems may require the assistance of an

aide for the route involved, and any such requirement may be suggested by the Contractor, subject to the prior written approval of the School District.

SAFETY PROGRAM

- a. The Contractor shall establish and maintain a plan for safety, including, but not limited to:
 1. Regularly scheduled in-service meetings for drivers and aides to include, but not limited to:
 - a) Defensive driver training.
 - b) Blood-borne pathogens training.
 - c) Conflict resolution training.
 2. Daily vehicle inspections.
 3. Driver supervisor to enforce good driving practices with respect to safety, mechanical operation, adherence to time schedules, and conformity with applicable laws and regulations.
 4. Two written bus driver evaluations per year by the bus manager with input from appropriate school administrators. Upon request, the written evaluations of the drivers shall be provided to the Superintendent or his designee.
 5. All driver applicants must meet acceptability requirements as indicated in 625ILCS 5/6-106.1. All drivers must participate in both classroom and on-the-road training programs devoted to safety, proper bus operation, rules and regulations, and first aid.
 6. All drivers must participate in a defensive driving course as certified by the National Safety Council or equivalent training program approved by the Cooperative.
 7. All drivers must be reviewed after thirty (30) days of employment and at least annually thereafter and must annually be given a review course on rules, regulations, safety and first aid.
- b. The Contractor shall ensure that drivers and dispatchers understand appropriate emergency procedures through regular in-service training meetings.
 1. The contractor will follow Districts' procedures for emergency cancellation of transportation in those cases where weather conditions may preclude the movement of buses. There shall not be a charge for services if a regular school day is cancelled.
 2. When extreme weather conditions or other emergencies require the early dismissal of school during the regular school day, the contractor shall transport students home from school. Specific arrangements for pickups and arrival times shall be coordinated between Districts and contractor.
- c. The Contractor shall prohibit any driver from driving a school bus while smoking or under influence of alcohol, non-prescription drugs or controlled substances. Every effort must be made to insure that drivers are in good health, and adequate provision must be made for substitute drivers when regular drivers are absent.
- d. The Contractor shall require all drivers not to begin their routes or not to move forward until all students are seated within the bus.

- e. The abstract of the driving record of each driver shall be obtained from the Secretary of State annually, subject to review if requested. Each driver shall undergo a drug test as part of his or her physical exam for each initial permit and each permit renewal. A positive test result shall disqualify a driver from providing service under this contract. Post accident testing is required. All drug and alcohol testing procedures shall be in strict compliance with State and Federal regulations.
- f. The Contractor shall perform criminal background checks for all drivers, as well as any other employees having contact with students. The contractor shall bear the sole responsibility of all costs incurred in providing qualified drivers or other personnel, such costs including but not limited to training, safety seminars, physical examinations, criminal background checks, drug tests, license and permit fees, recruitment expenses, salaries, fringe benefits and other conditions of employment. The Contractor shall provide copies of all such background checks. The Districts shall have the right to request that any employee of the Contractor be removed from performing any services for any reason. Following such a request, the Contractor shall immediately remove and replace the employee in question.
- g. All drivers shall maintain a neat and clean appearance at all times. They shall also display identification as employees of the contractor.

GENERAL REQUIREMENTS

- a. All laws, rules, regulations, ordinances of the federal, state, county or local government or orders heretofore or hereafter made or issued by the Superintendent of the State Board of Education or by the Superintendent of the Educational Service Region, Cook County, are to be made a part of this Contract as fully as though the same were herein set forth.
- b. This contract is for furnishing student transportation. In performing this contract, the Contractor is an independent contractor and not an officer, member, agent or employee of the School District.
- c. The Contractor shall assist the Board in completing all reports as may from time to time be required by the Board of Education, the Superintendent of the Illinois State Board of Education or any other entity or agency properly exercising jurisdiction over the subject matter of this Contract.
- d. In the case of all emergencies or accidents involving a vehicle, the District's Transportation Supervisor will be contacted immediately and informed of the situation. This contact shall first be by phone and then by written report. The severity of the situation will not be a factor in whether or not the Transportation Supervisor is notified. The Contractor is responsible in the event of any accident to follow established procedures, including the prompt obtaining of any necessary medical assistance and the notification of the responsible police department.
- e. This contract shall be governed and construed in accordance with the laws of the State of Illinois. If any provision hereof shall be held to contravene any applicable law, such provision shall be deemed reformed to the extent of conforming to said law, and in all other respects the terms hereof shall remain in full force and effect. Contractor shall comply with all

applicable laws, regulations and rules promulgated by the Federal, State, County, Municipal and/or other governmental unit or regulatory body now in effect or which may be in effect during the performance of the contract. Included within the scope of the laws, regulations and rules referred to in this paragraph, but in no way to operate as a limitation, are all forms of traffic regulations, public utility and Intrastate Commerce Commission regulations, Worker's Compensation Laws, the Social Security Act, Occupational Safety and Health Act, the Consumer Product Safety Act, the Illinois School Code and the Illinois Motor Vehicle Code.

Additionally, the Contractor shall comply with all laws and regulations pertaining to Equal Opportunity and Fair Employment Practices including the Illinois Human Rights Act. Contractor shall not discriminate against any worker, employee, or applicant, or any other member of the public because of race, religion, color, age, sex, handicap, marital status, sexual preference, national origin, or unsatisfactory military discharge, nor otherwise commit an unfair labor practice. Contractor further agrees that this article will be incorporated by Contractor in all contracts entered into with by suppliers of materials and services, subcontractors and at labor organizations, furnishing skilled, unskilled, or craft union skilled labor, or may perform any such labor or service in connection with this contract.

Further, Contractor certifies that it has adopted and implemented a written sexual harassment policy in full compliance with PA 87-1257 and Section 2-105A(4) of the Illinois Human Rights Act, 775 ILCS 5/2-105A(4), and in case of the Contractor having 25 or more employees, a drug-free workplace policy and practice in full compliance with Section 3 of the Illinois Drug-Free Workplace Act, 301 ILCS 580/3.

Finally, Contractor certifies that it is not ineligible for award of this contract by reason of debarment for a violation of any of the above-referenced laws and regulations and acknowledges that any breach of the foregoing provisions shall constitute a breach of this contract.

- f. Noncompliance is defined as, but not limited to, the failure to transport students on a bus route or routes as contracted or as requested in accordance with the terms of this contract, or the failure to make changes to routes as specified and directed by the Superintendent/Business Manager in accordance with the terms of this contract.

Should Districts find the Contractor in noncompliance with the provisions of its contract on a bus route or series of routes, the School District will be entitled to impose the following damages.

<u>Incident</u>	<u>Damages</u>
No service on any to or from regularly scheduled route	Daily rate per route x 300%
Late pick-up (10 minutes or more as defined on approved route sheet) at a school	10-29 minutes \$150 per day per route 30 or more minutes \$250 per day per route

Late drop-off (10 minutes or more as defined on approved route sheet) at a school	10-29 minutes \$150 per day per route 30 or more minutes \$250 per day per route
No shows for extra-curricular and sport routes	\$400 per occurrence
Tardiness for sports and extra-curricular route (10 minutes later than stipulated time)	10-29 minutes \$150 per day per route 30 or more minutes \$250 per day per route
Failure to provide a properly licensed and permitted driver for a to/from route	\$200 per day per route
Changes in a bus route(s) without notification	\$100 per day per occurrence
If the faculty sponsor of a trip must make alternate transportation arrangements because of Contractor actions	\$400 per occurrence plus expenses
Failure to provide bus video within 24 hours of request	\$150 per occurrence

The noncompliance damages for late pick-up and drop-off shall not apply during weather involving hazardous driving conditions.

A penalty shall be deducted from the first invoice following the noncompliance. The failure of School District to assess or collect any penalty under this Section shall not be considered a waiver of the School District's right to assess or collect that penalty in the future or a waiver with respect to any future violation committed by the Contractor.

- g. The Contractor agrees not to reassign or sell any rights to this Contract to another party or parties.
- h. The officers of the contracting bus company who sign this Contract covenant that the Contractor is duly authorized to conduct business in the State of Illinois and that they have authority to execute and deliver the Contract by and on behalf of the contracting bus company.
- i. All payments by the Board to the Contractor in connection with the Contract shall be made pursuant to the Local Government Prompt Payment Act unless otherwise expressly stated in the Contract Documents. Payments shall be made to the Contractor for daily to/from routes, after school activity routes, and extra-curricular sports routes based on routes and unit prices as bid or as subsequently amended per the inflation clause. These payments shall be made monthly September through June. A final reconciliation payment will be made not later than July 15th of each year. Payments for all other services under this contract, i.e., field trips, late routes, etc., shall be made monthly in arrears, upon submission by the Contractor of individual invoices covering the services provided.

- j. The contractor shall have a manager in charge of performance of this contract and furnish the name and address of such manager and the statement that such manager shall have complete authority with respect to all matters relating to the performance of this contract. This shall include matters relating to personnel and the changes and substitutions thereof, adherence to and changes in schedules and responsibility for keeping of records required under the terms of the contract. The manager should have a minimum of five (5) years experience in management of pupil transportation services. The contractor shall make every effort to maintain the same route supervisor for the school year.
- k. Current bussing school locations and current route information are highlighted in the attached Summary of Experience. Totals are approximations only and are in no way intended to be final figures. As many routes as possible should be designed to run two or more programs back to back whenever possible in order to minimize costs to said districts.

A. Termination of Contract.

- a. The School District may terminate this contract at any time during the contract period by providing written notice of said termination to the Contractor at least thirty days prior to the termination date.
- b. The sole right to determine whether or not the quality of service during the term of this contract is maintained, at the standard previously established, is the discretion of the Districts. The parties further agree that any failure to meet this standard of services constitutes a breach of this contract and constitutes sufficient reason to terminate the contract as set forth below.
- c. If, at any time, the Contractor fails to comply with the terms of this Agreement, or does not fully perform and strictly adhere to any of the terms hereof required to be performed or adhered to by Contractor, or its drivers, or employees, the Board may, in addition to other remedies and/or penalties provided for herein, and in its sole discretion, terminate this Agreement as provided herein, with prejudice.
- d. In the event that the Board determines that the Contractor has failed to comply with, fully perform, or strictly adhere to this Agreement, the Board may send written notice at least thirty (30) days in advance to the Contractor indicating the intention of the Board to declare the Contractor in default. In such notice, the Board will state in what respect the Contractor has failed to comply with the terms of this Agreement, and will state a date certain upon which the Agreement will terminate unless the Contractor, prior to such date, cures the defect to the satisfaction of the Board. If, prior to the date of termination stated in the notice as aforesaid, the Board notifies the Contractor that the defect has been cured, this Agreement will not terminate on the date stated in the notice but will be deemed to have remained in effect as of the date such notice was given. In the event that the Board does not so notify the Contractor that the defect has been cured as aforesaid, this Agreement is terminated without further action by the Board on the date of termination stated in the notice and in such event, the bond posted by the Contractor shall be paid to the Board of Education without further proceedings or notice.

- e. The date of termination stated in the notice of intent to declare the Contractor in default, as provided in "A" above, may not be sooner than 30 calendar days following the date of such notice unless there is a complete failure by the Contractor to provide the services required by this contract, in which event the date of termination may be 5 calendar days following the date of such notice.
- f. The right of the Board to terminate this Agreement as provided in Paragraph O, is cumulative with all other rights of the Board contained herein. The Board's failure to send a Notice of Default to the Contractor shall not be deemed a waiver of the Board's right to terminate the operating Agreement under this Paragraph O.

Notices.

All notices required under this Agreement shall be sent in writing by regular and certified mail to the following addresses:

To the Board:

Board of Education
ADDRESS
CITY, STATE and ZIP

To the Contractor:

CONTRACTOR, Inc.
ADDRESS
CITY, STATE and ZIP

If further assistance is required in the preparation of this proposal, please contact Mr. Eric Trimberger, Assistant Superintendent for Business/CSBO, at eritri@d219.org.

Name of Bidder (please print)

Bid Submitted by

Address

Title

Phone number

Date

CERTIFICATION REGARDING GENERAL UNDERSTANDING AND ACCEPTANCE OF BID CONDITIONS

I have read and understand the information included in this Student Bus Transportation bid packet and have bid accordingly. I have provided all necessary information and have checked all computations. The proposal has been submitted with each space properly completed. I understand that no claim for relief because of errors or omissions in the bidding will be considered, and bidders will be held strictly to the proposals as submitted.

Name of Bidder (please print)	Bid Submitted by (signature)
Address	Title
Phone number	Date

The Contractor listed above is:

Minority owned Business:	Yes _____	No _____
Female owned Business:	Yes _____	No _____
Business owned by persons with disabilities:	Yes _____	No _____
Locally owned Business:	Yes _____	No _____

IN WITNESS WHEREOF, the parties hereto, through their duly authorized officers or representatives, have executed this Agreement as of the Effective Date set forth above.

CERTIFICATE OF ELIGIBILITY TO BID

_____ (contractor), pursuant to section 33E-11 of the Illinois Criminal Code of 1961 as amended, hereby certifies that neither (he, she, it) nor any of (his, her, its) partners, officers, or owners of (his, her, its) business has been convicted in the past five (5) years of the offense of bid-rigging under section 33E-3 of the Illinois Criminal Code of 1961 as amended and that neither (he, she, it) nor any of (his, her, its) partners, officers or owners of (his, her, its) business has ever been convicted of the offense of bid-rotating under section 33E-4 of the Illinois Criminal Code of 1961 as amended.

Date: _____

_____ Name of Contractor/Company

_____ Street Address

_____ City, State, Zip Code

_____ Title of Officer

_____ Name of Officer (Typed)

_____ Signature of Officer

Criminal Background Check Certification

Contractor hereby represents, warrants and certifies that in accordance with Section 10-21.9 of the *Illinois School Code* efforts have been made to screen applicants and to perform background checks to ensure that Contractor’s employees who will serve the District under this Contract have no prior criminal record that would render said persons as prohibited from working in a school setting, e.g., child molestation, pornography, etc. Contractor will also be and remain in compliance with current and future local, state, and federal laws and regulations regarding this matter.

Contractor further agrees that it shall not employ any person, including but not limited to school bus drivers and other transportation employees, who have or may have direct, daily contact with the pupils of any school in the District, and for whom a criminal background investigation has not been conducted pursuant hereto, and further represents and agrees that all applicants for any such employment shall furnish with their applications the written “Authorization of Criminal Background Information from, which is attached to the Contract Documents as Attachment H, authorizing the Board of Education to request a criminal background investigation of said applicant pursuant to Section 10-21.9 of the *Illinois School Code* and to receive criminal history record information pursuant thereto to determine if the applicant has been convicted of committing or attempting to commit any of the criminal or drug offenses enumerated in Section 10-21.9. Contractor further agrees to submit with said authorization payment for any costs and expenses associated with the criminal background investigation.

Carrier further represents, warrants, and certifies that no applicant for employment with respect to whom the criminal investigation reveals any conviction for committing and/or attempting to commit any of the enumerated offenses set forth in Section 10-21.9 of the *Illinois School Code*, shall be employed thereby in any position that involves or may involve contact with the students of the School District.

This certification is executed on the date hereinafter indicated by the designated Contractor by its duly authorized officer.

_____ Date: _____
Name of Contractor

_____ Name and Title
Contractor’s Signature

NON-COLLUSION AFFIDAVIT

The undersigned bidder or agent, being truly sworn, on oath that he has not, nor has any other member, representative or agent of the firm, company, corporation or partnership represented by him, entered into any combination, collusion or agreement with any person relative to the price to be bid by anyone at such letting, not to prevent any person from bidding nor to induce anyone to refrain from bidding, and that bid is made without reference to any other bid and without any agreement, understanding or combination with any other person in reference to such bidding.

He further says that no person or persons, firms, or corporations has, have, or will receive directly or indirectly, any rebate, fee, gift, commission or thing of value on account of such sale.

Firm or Corporation Official

On behalf of:

Firm or Corporation

Subscribed and sworn to before me this _____ day of _____ (month/year).

My commission expires:

Date: _____

Signature: _____

OWNER'S CONTRACTUAL LIABILITY PROTECTION

The contractor shall at all times save the School District and the Board of Education harmless against loss from Liability imposed by law upon them for damages on account of bodily injuries or death suffered or alleged to have been suffered, as a result of any accident occurring from or by reason of, or in course of operations under contract, whether occurring by reason of acts or omissions of Contractor or any Subcontractor, or both.

The Contractor shall at all times save the School District and the Board of Education harmless against loss from Liability imposed by law upon them for damages on account of injuries to property suffered or alleged to have been suffered as a result of any accident occurring from reason of or in course of operations under Contract, whether occurring by reason of acts or omissions or Contractor of any Subcontractor, or both, insuring School District and Board of Education against loss from Liability imposed by law upon them for damages on account of such injuries or loss.

Firm or Corporation Official

On behalf of:

Firm or Corporation

Subscribed and sworn to before me this _____ day of _____ (month/year).

My commission expires:

Date: _____ Signature: _____

Statement of Non- Discrimination

As part of my proposal on a contract to provide transportation, I certify:

1. That in the hiring of employees for the performance of work under this Contract or any subcontract, as Contractor, or any persons acting on the Contractor’s behalf, shall not, by reason of race, creed, color, national origin, age, sexual orientation, marital status, citizenship status, arrest record, being a victim of domestic or sexual violence, mental or physical handicap or disability, military status or unfavorable discharge from military service, discriminate against any citizen of the State in the employment of labor or workers who are qualified and available to perform the work to which the employment relates.

2. That no contractor, subcontractor, nor a person acting on the contractor’s behalf shall not, in any manner, discriminate against or intimidate any employee hired for the performance of work under this Contract on account of race, creed, color, national origin, age, sex, religion, sexual orientation, marital status, citizenship status, arrest record, being a victim of domestic violence, mental or physical handicap or disability or unfavorable discharge from military service.

3. For the performance of the Contract, the Contractor shall agree as follows: That all contractors or subcontractors will comply with all the state laws regarding nondiscrimination. The Contractor will take affirmative action to ensure that applicants are employed, and that employees are treated during employment, without regard to their race, creed, color, national origin, age, sex, religion, sexual orientation, marital status, citizenship status, arrest record, being a victim of domestic or sexual violence, mental or physical handicap, or disability, military status or unfavorable discharge from military service.

Furthermore, it is understood that the undersigned has been given the authority to represent the company herein listed below.

Firm or Corporation Official

On behalf of:

Firm or Corporation

Subscribed and sworn to before me on this _____ day of _____ (month/year)
My commission expires:

Date: _____

Signature: _____

CERTIFICATE REGARDING EQUAL EMPLOYMENT OPPORTUNITY

The undersigned hereby certifies that the Bidder is in compliance with the Equal Employment Opportunity Act and the Illinois Fair Employment Practices Act as stated under Compliance with Legislation in Instructions to Bidder.

Name of Bidder (Please Print)

Submitted by (Signature)

Title

TRANSPORTATION CONTRACT

**AGREEMENT made the _____ day of _____, 2015, between
_____ SCHOOL DISTRICT
(hereinafter referred to as the "District") and CONTRACTOR, INC. (hereinafter referred to
as the "Contractor").**

Term of Contract.

The Contractor, for and in consideration of the payments to be made as hereinafter set forth in the Cost Schedule attached hereto as Appendix A, hereby agrees to transport students that the District must transport by law and students that have independently agreed to pay for transportation to and from the schools of the Districts and all special routes as defined herein as well as all students requiring transportation for extracurricular activities including activity trips, field trips, and transportation for such events as are required by the Board or its authorized agent from August 1, 2015, through July 31, 2018. The term of this contract may be extended at the option of the District for two (2) additional one (1) year periods. Notice of the extension of the contract shall be provided to the Contractor in writing not later than March 31st of the year of termination.

Local Office and On-Duty Dispatcher/Manager.

The Contractor shall maintain a local bus office parking lot and bus garage within Niles Township or within a ten-mile radius of the intersection of Skokie Boulevard and Oakton Street in Skokie, Illinois. The local office shall be staffed with a manager and at least one dispatcher from 6:00 a.m. to 6:00 p.m. on school days. When buses are in use outside of this time period, a dispatcher or manager will be available by cell phone and pager within five (5) minutes to respond to concerns of the School District.

Indicate the location where the buses will be housed and maintained. The facility must house all functions, including storage of buses, maintenance and dispatch operations of the contractor.

Contract Documents.

The "Contract Documents" shall consist of this Agreement, the Bid Specifications (including but not limited to the Instructions to Bidders, References, all requisite certifications, bid and performance bonds, insurance, and bid form), the Cost Schedule attached as Appendix A. Appendix C and D to this document are merely to assist in the bidding process, and shall not be deemed binding contractual requirements. The Bid Specifications and the Cost Schedule are hereby incorporated into this Agreement as though they were fully set forth herein and shall have the same force and effect as any other provision in this Agreement. In the event of a conflict between the Bid Specifications and this Agreement, the Bid Specifications shall prevail. Upon award of this Contract, the Bid Specifications will be attached hereto as Appendix B, and the Cost Schedule is attached hereto as Appendix A. In attaching, it is the intent of the parties that both appendices are hereby made a part of this Agreement.

Hold Harmless Agreement

The Contractor agrees to indemnify, hold harmless, and defend the Boards of Education of Districts, its officials, employees and agents from and against all suits, actions, legal proceedings, claims, demands, damages, losses, and expenses, including attorneys' fees, in any manner caused by, arising from, incident to, connected with or growing out of the operation of school buses and other vehicles used to transport students under this Contract, in accordance with the liability insurance policies procured by Contractor under this Agreement. Said policies are subject to review and approval by the District.

Document Supremacy

In the event any term or provision of one Contract Document conflicts with a term or provision of another, the term or provision of the Contract shall prevail over all other documents. The terms and provisions of the bid specifications shall prevail over the bid sheet.

Compensation

Contractor shall provide all services as awarded by District and shall be compensated according to the terms of the bid specifications and the Attachments in the amounts listed in the bid sheet submitted by Contractor.

Complete Understanding

This Agreement sets forth all of the promises, agreements, conditions, and understandings between the parties relative to the subject matter hereof, and no other promises, agreements, or understandings, whether oral or written, expressed or implied, exist between the parties.

Amendments

No subsequent alteration, amendment, change, addition, deletion, or modification to this Agreement shall be binding upon the parties hereto unless reduced to writing and duly authorized and signed by each of them.

WHEREAS, the Parties have duly executed and entered into this Contract as of the day and year set forth above.

BOARD OF EDUCATION

CONTRACTOR, INC.

By: _____
President, Board of Education

By _____
Authorized Representative

Attest: _____
Secretary, Board of Education

Attest: _____

APPENDIX A – INSERT COMPLETED BID SHEETS

APPENDIX B – BID SPECIFICATIONS

To be inserted as part of Contract post-bid

APPENDIX C

TRANSPORTATION REQUIREMENTS

District boundaries and current route maps, for purposes of assisting in preparing bid, are attached to this Appendix as Exhibit A.

NILES TOWNSHIP HIGH SCHOOL DISTRICT 219

The following information depicts the regular school day transportation needs for Niles Township High School District 219.

Niles West High School

AM Routes = 25

PM Routes = 22

After School Activity Routes = 4

After School Athletic Routes = 3

Niles North High School

AM Routes = 24

PM Routes = 17

After School Activity Routes = 4

After School Athletic Routes = 3

MORTON GROVE SCHOOL DISTRICT 70

Parkview School

AM Routes = 11

PM Routes = 11

Mid Day Routes = 1 (AM and PM – the same bus loops)

5 Early release days 3 at 1:30, 2 at 11:45

NILES SCHOOL DISTRICT 71

Clarence Culver School

AM Routes = 5

PM Routes @ 3:00 PM = 5

Late Activity Route = 1 M-Th 4:00

LINCOLNWOOD SCHOOL DISTRICT 74

Lincoln Hall, Rutledge Hall and Todd hall all on one campus.

AM Routes = Lincoln Hall is paired with Todd Hall 8 double run routes total,

Rutledge Hall 8 routes

PM Routes = Rutledge Hall is paired with Lincoln Hall 8 double run routes total

Todd Hall 8 routes

Todd Hall has 2 Mid-Day routes at 11:10

Early Activity-4 Routes arrive at 7:20

Late Activity-2 Routes leave at 4:20

ADDITIONAL INFORMATION

**ACTUAL EXPENSES AND BUDGETS
2013-2014**

DISTRICT	REGULAR ED	SPECIAL ED	EXTRA	SUMMER
219	1,875,412	972,796	433,365	81,029
70	233,119		30,259	
71	100,234		24,751	
74	282,874		52,246	

2014-2015 BUDGET

DISTRICT	REGULAR ED	SPECIAL ED	EXTRA	SUMMER
219	1,760,000	1,000,000	427,000	122,310
70	275,000		30,000	
71	110,000		36,000	
74	610,000		70,000	

MILES

2013-2014

DISTRICT	REGULAR ED	SPECIAL ED		
219	76,308	226,192		
70	9,328			
71	10,912			
74	21,120			

APPENDIX D

BELL TIMES

NILES TOWNSHIP HIGH SCHOOL DISTRICT 219

The following information depicts the regular school day transportation needs for Niles Township High School District 219.

Niles West High School

8:10 AM – 3:23 PM

Niles North High School

8:10 AM – 3:23 PM

Late Start/Early Dismissal are what times??? Activity Bus???

MORTON GROVE SCHOOL DISTRICT 70

Parkview School 8:20 AM – 3:20 PM busses arrive by 8:15

NILES SCHOOL DISTRICT 71

Clarence Culver School

8:00 AM – 3:00 PM

Activity Bus M- TH @ 4:00 PM

LINCOLNWOOD SCHOOL DISTRICT 74

Todd Hall 8:25 AM – 2:55 PM, AM PK 8:25-11:10, PM PK 12:10-2:55 PM

Rutledge Hall 8:00 AM – 2:45

Lincoln Hall 8:00 AM – 3:20 PM

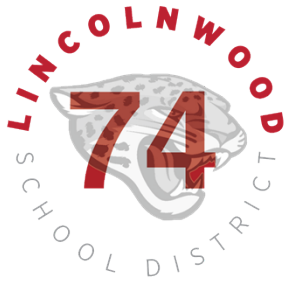

Executive Summary Board of Education Meeting

DATE: June 1, 2023

TOPIC: FY24 & FY25 Audit Services

PREPARED BY: Courtney Whited

Recommended for:

- Action
- Discussion
- Information

Purpose/Background:

The Board of Education approves all expenditures greater than \$10,000.

District Legal Counsel has reviewed Lauterbach & Amen's letter of engagement for audit services spanning fiscal years 2023, 2024 and 2025. It was noted, there is no venue or method of dispute resolution specified. This was deemed acceptable, as Cook County is not ruled out and Lauterbach & Amen's county of DuPage is an acceptable venue. The letter references a restriction on soliciting or hiring any Lauterbach personnel which should not be problematic. The District's current engagement letter technically has the current fiscal year (FY 2023) under contract with them, essentially at the same fee rate. However, this new letter includes a fee for the federal Single Audit that is now required, which was not included in the prior engagement letter, and that is certainly not a problem. Lauterbach & Amen has established an excellent record of service with the District since the partnership began in 2015.

Fiscal Impact:

Not to exceed \$83,400 for three fiscal years of audit services with possible single audits

FY 2025 Audit + Single Audit, if necessary	FY 2024 Audit + Single Audit, if necessary	FY 2023 Audit + Single Audit
\$24,550 + \$4,300	\$23,650 + 4,150	\$22,750 + \$4,000

Recommendation:

The Finance Committee concurs with the Administration to recommend to the Board of Education to retain the firm of Lauterbach & Amen, LLP over the course of three fiscal years spanning 2023-2025 for audit and single audit services not to exceed \$83,400.



February 27, 2023

Members of the Board of Education
Lincolnwood School District 74
Lincolnwood, Illinois

We are pleased to confirm our understanding of the services we are to provide the Lincolnwood School District 74, Illinois for the years ended June 30, 2023, June 30, 2024, and June 30, 2025.

Audit Scope and Objectives

We will audit the financial statements of the governmental activities, each major fund, and the aggregate remaining fund information, and the disclosures, which collectively comprise the basic financial statements of the District as of and for the years ended June 30, 2023, June 30, 2024, and June 30, 2025. Accounting standards generally accepted in the United States of America (GAAP) provide for certain required supplementary information (RSI), such as management's discussion and analysis (MD&A), to supplement the District's basic financial statements. Such information, although not a part of the basic financial statements, is required by the Governmental Accounting Standards Board who considers it to be an essential part of financial reporting for placing the basic financial statements in an appropriate operational, economic, or historical context. As part of our engagement, we will apply certain limited procedures to the District's RSI in accordance with auditing standards generally accepted in the United States of America (GAAS). These limited procedures will consist of inquiries of management regarding the methods of preparing the information and comparing the information for consistency with management's responses to our inquiries, the basic financial statements, and other knowledge we obtained during our audit of the basic financial statements. We will not express an opinion or provide any assurance on the information because the limited procedures do not provide us with sufficient evidence to express an opinion or provide any assurance. The following RSI is required by GAAP and will be subjected to certain limited procedures but will not be audited: management's discussion and analysis, the budgetary comparison schedules, and GASB-required pension and other postemployment benefit (OPEB) reporting.

We have also been engaged to report on supplementary information other than RSI that accompanies the District's financial statements. We will subject the following supplementary information to the auditing procedures applied in our audit of the financial statements and certain additional procedures, including comparing and reconciling such information directly to the underlying accounting and other records used to prepare the financial statements or to the financial statements themselves, and other additional procedures in accordance with GAAS, and we will provide an opinion on it in relation to the financial statements as a whole, in a report combined with our auditor's report on the financial statements: combining and individual fund statements and budgetary comparison schedules, and other information listed as supplemental schedules.

Audit Scope and Objectives – Continued

The objectives of our audit are to obtain reasonable assurance as to whether the financial statements as a whole are free from material misstatement, whether due to fraud or error; issue an auditor's report that includes our opinion about whether your financial statements are fairly presented, in all material respects, in conformity with GAAP; and report on the fairness of the supplementary information referred to in the second paragraph when considered in relation to the financial statements as a whole. Reasonable assurance is a high level of assurance but is not absolute assurance and therefore is not a guarantee that an audit conducted in accordance with GAAS and *Government Auditing Standards* will always detect a material misstatement when it exists. Misstatements, including omissions, can arise from fraud or error and are considered material if there is a substantial likelihood that, individually or in the aggregate, they would influence the judgment of a reasonable user made based on the financial statements.

The objectives also include reporting on internal control over financial reporting and compliance with provisions of laws, regulations, contracts, and award agreements, noncompliance with which could have a material effect on the financial statements in accordance with *Government Auditing Standards*.

Auditor's Responsibilities for the Audit of the Financial Statements

We will conduct our audit in accordance with GAAS and the standards for financial audits contained in *Government Auditing Standards*, issued by the Comptroller General of the United States, and will include tests of your accounting records of the District and other procedures we consider necessary to enable us to express such opinions. As part of an audit in accordance with GAAS and *Government Auditing Standards*, we exercise professional judgment and maintain professional skepticism throughout the audit.

We will evaluate the appropriateness of accounting policies used and the reasonableness of significant accounting estimates made by management. We will also evaluate the overall presentation of the financial statements, including the disclosures, and determine whether the financial statements represent the underlying transactions and events in a manner that achieves fair presentation. We will plan and perform the audit to obtain reasonable assurance about whether the financial statements are free of material misstatement, whether from (1) errors, (2) fraudulent financial reporting, (3) misappropriation of assets, or (4) violations of laws or governmental regulations that are attributable to the District or to acts by management or employees acting on behalf of the District. Because the determination of waste and abuse is subjective, *Government Auditing Standards* do not expect auditors to perform specific procedures to detect waste or abuse in financial audits nor do they expect auditors to provide reasonable assurance of detecting waste or abuse.

Because of the inherent limitations of an audit, combined with the inherent limitations of internal control, and because we will not perform a detailed examination of all transactions, there is an unavoidable risk that some material misstatements may not be detected by us, even though the audit is properly planned and performed in accordance with GAAS and *Government Auditing Standards*. In addition, an audit is not designed to detect immaterial misstatements or violations of laws or governmental regulations that do not have a direct and material effect on the financial statements. However, we will inform the appropriate level of management of any material errors, fraudulent financial reporting, or misappropriation of assets that comes to our attention. We will also inform the appropriate level of management of any violations of laws or governmental regulations that come to our attention, unless clearly inconsequential. Our responsibility as auditors is limited to the period covered by our audit and does not extend to any later periods for which we are not engaged as auditors.

Auditor's Responsibilities for the Audit of the Financial Statements – Continued

We will also conclude, based on the audit evidence obtained, whether there are conditions or events, considered in the aggregate, that raise substantial doubt about the District's ability to continue as a going concern for a reasonable period of time.

Our procedures will include tests of documentary evidence supporting the transactions recorded in the accounts, tests of the physical existence of inventories, if applicable, and direct confirmation of receivables and certain assets and liabilities by correspondence with selected customers, creditors, and financial institutions. We will also request written representations from your attorneys as part of the engagement.

We have identified the following significant risks of material misstatement as part of our audit planning: management override of controls, improper revenue recognition, increased regulations by oversight bodies or granting agencies, and general or local economic challenges. Planning for this engagement has not concluded and is subject to change.

Our audit of the financial statements does not relieve you of your responsibilities.

Audit Procedures – Internal Control

We will obtain an understanding of the District and its environment, including internal control relevant to the audit, sufficient to identify and assess the risks of material misstatement of the financial statements, whether due to error or fraud, and to design and perform audit procedures responsive to those risks and obtain evidence that is sufficient and appropriate to provide a basis for our opinions. Tests of controls may be performed to test the effectiveness of certain controls that we consider relevant to preventing and detecting errors and fraud that are material to the financial statements and to preventing and detecting misstatements resulting from illegal acts and other noncompliance matters that have a direct and material effect on the financial statements. Our tests, if performed, will be less in scope than would be necessary to render an opinion on internal control and, accordingly, no opinion will be expressed in our report on internal control issued pursuant to *Government Auditing Standards*. The risk of not detecting a material misstatement resulting from fraud is higher than for one resulting from error, as fraud may involve collusion, forgery, intentional omissions, misrepresentation, or the override of internal control. An audit is not designed to provide assurance on internal control or to identify significant deficiencies or material weaknesses. Accordingly, we will express no such opinion. However, during the audit, we will communicate to management and those charged with governance internal control related matters that are required to be communicated under AICPA professional standards and *Government Auditing Standards*.

Audit Procedures – Compliance

As part of obtaining reasonable assurance about whether the financial statements are free of material misstatement, we will perform tests of District's compliance with the provisions of applicable laws, regulations, contracts, agreements, and grants. However, the objective of our audit will not be to provide an opinion on overall compliance, and we will not express such an opinion in our report on compliance issued pursuant to *Government Auditing Standards*.

Other Services

We will also assist in preparing the financial statements and required audit adjustments, if any, for the District in conformity with accounting principles generally accepted in the United States of America based on information provided by you. These nonaudit services do not constitute an audit under Government Auditing Standards and such services will not be conducted in accordance with *Government Auditing Standards*. We will perform the services in accordance with applicable professional standards. The other services are limited to the financial statement services previously defined. We, in our sole professional judgment, reserve the right to refuse to perform any procedure or take any action that could be construed as assuming management responsibilities.

You agree to assume all management responsibilities relating to the financial statements and related notes and any other nonaudit services we provide. You will be required to acknowledge in the management representation letter our assistance with preparation of the financial statements and related notes and that you have reviewed and approved the financial statements and related notes prior to their issuance and have accepted responsibility for them. Further, you agree to oversee the nonaudit services by designating an individual, preferably from senior management, with suitable skill, knowledge, or experience; evaluate the adequacy and results of those services; and accept responsibility for them.

Responsibilities of Management for the Financial Statements

Our audit will be conducted on the basis that you acknowledge and understand your responsibility for designing, implementing, establishing, and maintaining effective internal controls relevant to the preparation and fair presentation of financial statements that are free from material misstatement, whether due to fraud or error, and for evaluating and monitoring ongoing activities to help ensure that appropriate goals and objectives are met; following laws and regulations; and ensuring that management and financial information is reliable and properly reported. Management is also responsible for implementing systems designed to achieve compliance with applicable laws, regulations, contracts, and grant agreements. You are also responsible for the selection and application of accounting principles, for the preparation and fair presentation of the financial statements and all accompanying information in conformity with accounting principles generally accepted in the United States of America, and for compliance with applicable laws and regulations and the provisions of contracts and grant agreements.

Management is responsible for making drafts of financial statements, all financial records, and related information available to us and for the accuracy and completeness of that information (including information from outside of the general and subsidiary ledgers). You are also responsible for providing us with (1) access to all information of which you are aware that is relevant to the preparation and fair presentation of the financial statements, such as records, documentation, identification of all related parties and all related-party relationships and transactions, and other matters; (2) additional information that we may request for the purpose of the audit; and (3) unrestricted access to persons within the government from whom we determine it necessary to obtain audit evidence. At the conclusion of our audit, we will require certain written representations from you about your responsibilities for the financial statements; compliance with laws, regulations, contracts, and grant agreements; and other responsibilities required by GAAS and *Government Auditing Standards*.

Responsibilities of Management for the Financial Statements – Continued

Your responsibilities include adjusting the financial statements to correct material misstatements and for confirming to us in the written representation letter that the effects of any uncorrected misstatements aggregated by us during the current engagement and pertaining to the latest period presented are immaterial, both individually and in the aggregate, to the financial statements of each opinion unit taken as a whole.

You are responsible for the design and implementation of programs and controls to prevent and detect fraud, and for informing us about all known or suspected fraud affecting the government involving (1) management, (2) employees who have significant roles in internal control, and (3) others where the fraud could have a material effect on the financial statements. Your responsibilities include informing us of your knowledge of any allegations of fraud or suspected fraud affecting the government received in communications from employees, former employees, grantors, regulators, or others. In addition, you are responsible for identifying and ensuring that the government complies with applicable laws, regulations, contracts, agreements, and grants and for taking timely and appropriate steps to remedy fraud and noncompliance with provisions of laws, regulations, or contracts or grant agreements that we report.

You are responsible for the preparation of the supplementary information, which we have been engaged to report on, in conformity with accounting principles generally accepted in the United States of America (GAAP). You agree to include our report on, the supplementary information in any document that contains, and indicates that we have reported on the supplementary information. You also agree to make the audited financial statements readily available to users of the supplementary information no later than the date the supplementary information is issued with our report thereon. Your responsibilities include acknowledging to us in the representation letter that (1) you are responsible for presentation of the supplementary information in accordance with GAAP; (2) you believe the supplementary information, including its form and content, is fairly presented in accordance with GAAP; (3) the methods of measurement or presentation have not changed from those used in the prior period (or, if they have changed, the reasons for such changes); and (4) you have disclosed to us any significant assumptions or interpretations underlying the measurement or presentation of the supplementary information.

Management is responsible for establishing and maintaining a process for tracking the status of audit findings and recommendations. Management is also responsible for identifying and providing report copies of previous financial audits, attestation engagements, performance audits or other studies related to the objectives discussed in the Audit Scope and Objectives section of this letter. This responsibility includes relaying to us corrective actions taken to address significant findings and recommendations resulting from those audits, attestation engagements, performance audits, or other studies. You are also responsible for providing management's views on our current findings, conclusions, and recommendations, as well as your planned corrective actions, for the report, and for the timing and format for providing that information.

Engagement Administration, Fees, and Other

We will provide copies of our reports to the District; however, management is responsible for distribution of the reports and the financial statements. Unless restricted by law or regulation, or containing privileged and confidential information, copies of our reports are to be made available for public inspection.

The audit documentation for this engagement is the property of Lauterbach & Amen, LLP and constitutes confidential information. However, subject to applicable laws and regulations, audit documentation and appropriate individuals will be made available upon request and in a timely manner to the cognizant agency or oversight agency or its designee, a federal agency providing direct or indirect funding, or the U.S. Government Accountability Office for purposes of a quality review of the audit, to resolve audit findings, or the carry out oversight responsibilities. We will notify you of any such request. If requested, access to such audit documentation will be provided under the supervision of Lauterbach & Amen, LLP personnel. Furthermore, upon request, we may provide copies of selected audit documentation to the aforementioned parties. These parties may intend, or decide, to distribute the copies or information contained therein to others, including other governmental agencies.

The audit documentation for this engagement will be retained for a minimum of five years after the report release or for any additional period requested by the cognizant agency, oversight agency or pass-through entity. If we are aware that a federal awarding agency, pass-through entity, or auditee is contesting an audit finding, we will contact the party(ies) contesting the audit finding for guidance prior to destroying the audit documentation.

Our fees for the June 30, 2023, June 30, 2024, and June 30, 2025 audits will be as follows:

Service Provided	June 30, 2023	June 30, 2024	June 30, 2025
Audit	\$21,000	\$21,900	\$22,800
Single Audit *	\$4,000	\$4,150	\$4,300
DDO	\$250	\$250	\$250
ACFR **	\$1,500	\$1,500	\$1,500

* - Fee for 1 Major Program. Additional \$1,500 for any additional programs required to be tested

** - \$1,500 in the year of implementation and \$750 for future years

The District agrees that during the term of this agreement and for a period of twelve months thereafter, the District shall not solicit, or arrange an employment contract with personnel of Lauterbach & Amen, LLP. Violation of this provision shall, in addition to other relief, require the District to compensate Lauterbach & Amen, LLP with one hundred percent of the solicited person’s annual compensation.

Reporting

We will issue a written report upon completion of the District's financial statements. Our reports will be addressed to the Board of Education of the District. Circumstances may arise in which our report may differ from its expected form and content based on the results of our audit. Depending on the nature of these circumstances, it may be necessary for us to modify our opinions, add a separate section, or add an emphasis-of-matter or other-matter paragraph to our auditor's report, or if necessary, withdraw from this engagement. If our opinions are other than unmodified, we will discuss the reasons with you in advance. If, for any reason, we are unable to complete the audit or are unable to form or have not formed opinions, we may decline to express opinions or issue reports, or we may withdraw from this engagement.

We will also provide a report (that does not include an opinion) on internal control related to the financial statements and compliance with the provisions of laws, regulations, contracts, and grant agreements, noncompliance with which could have a material effect on the financial statements as required by *Government Auditing Standards*. The report on internal control and on compliance and other matters will state (1) that the purpose of the report is solely to describe the scope of testing of internal control and compliance, and the results of that testing, and not to provide an opinion on the effectiveness of the entity's internal control on compliance, and (2) that the report is an integral part of an audit performed in accordance with *Government Auditing Standards* in considering the entity's internal control and compliance. The report will also state that the report is not suitable for any other purpose. If during our audit we become aware that District is subject to an audit requirement that is not encompassed in the terms of this engagement, we will communicate to management and those charged with governance that an audit in accordance with U.S. generally accepted auditing standards and the standards for financial audits contained in *Government Auditing Standards* may not satisfy the relevant legal, regulatory, or contractual requirements.

We appreciate the opportunity to be of service to the Lincolnwood School District 74, Illinois and believe this letter accurately summarizes the significant terms of our engagement. If you have any questions, please let us know. If you agree with the terms of our engagement as described in this letter, please sign and return it to us.

Cordially,

Lauterbach & Amen, LLP
LAUTERBACH & AMEN, LLP

RESPONSE:

This letter correctly sets forth the understanding of the Lincolnwood School District 74, Illinois.

By: _____

Title: _____

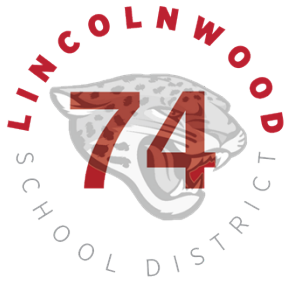

Executive Summary Board of Education Meeting

DATE: June 1, 2023

TOPIC: GASB 74/75 Actuarial Valuation Services from Lauterbach & Amen, LLP

PREPARED BY: Courtney Whited

Recommended for:

- Action
- Discussion
- Information

Purpose/Background:

The Board approves all contracts. A GASB 74/75 actuarial valuation must be included as part of the District’s annual financial reporting obligations. The valuation provides estimated costs of Other Post-Employment Benefits (OPEB). Currently, Lauterbach & Amen, LLP is under contract to perform the District’s audits through June 30, 2023. The two-year term on this actuarial services agreement will align both the actuarial and audit services to the same timeline. The District’s Legal Counsel stated the proposed letter is acceptable. Furthermore, the additional contract certification drafted by the former legal team was updated relative to indemnification and minimum insurance coverage levels that are beneficial for the District.

Fiscal Impact:

\$4,910 over the course of two years, as follows:

June 30, 2025	June 30, 2024	June 30, 2023	June 30, 2022
\$1,020	\$3,890	\$940	\$3,600

Recommendation:

The Finance Committee concurs with the Administration to recommend to the Board of Education to approve the contract with Lauterbach & Amen, LLP for actuarial services associated with determining the value of GASB 74/75 Other Post-Employment Benefits (OPEB) for the year ending June 30, 2024 for \$3,890 and the year ending June 30, 2025 for \$1,020.

SCHOOL DISTRICT CONTRACT CERTIFICATION

The Contractor identified below agrees to provide services to Lincolnwood School District No. 74 (the “District”) per the terms and conditions stated herein and in Exhibit A, which is incorporated herein. The Contractor certifies that its officers, employees, and agents are not barred from bidding and entering into an agreement with the District as a result of a violation of the Bid Rigging or Bid Rotating provisions of the Public Contracts Section of the Illinois *Criminal Code of 1961* (720 ILCS 5/33E-3, 33E-4) or otherwise under the Illinois *School Code* (105 ILCS 5/10-20.21). The Contractor acknowledges that the District’s Board of Education may declare the agreement void if it finds this certification is false. As required by law, the Contractor certifies that it and all its affiliates will collect and remit Illinois Use Tax on all sales of tangible personal property into the State of Illinois in accordance with the provisions of the Illinois *Use Tax Act* (35 ILCS 105/1 *et seq.*) regardless of whether the Contractor or its affiliate is a “retailer maintaining a place of business within this State” as defined in Section 2 of the *Use Tax Act* (35 ILCS 105/2). The Contractor further certifies that to the extent applicable, it will provide a drug free workplace as required by the Illinois *Drug Free Workplace Act* (30 ILCS 580/1 *et seq.*). Contractor further agrees to comply with all other applicable state and federal laws and regulations. As required by regulation of the Illinois Department of Human Rights, the Equal Opportunity Clause contained in Exhibit B and the representations therein are hereby incorporated into this Certification.

Contractor acknowledges that it is unlawful for a child sex offender to knowingly be present on school property when persons under the age of 18 are present without the specific notification to and permission of the Superintendent of Schools.

Contractor shall indemnify, defend, and hold harmless the Board of Education, its individual Board members, Board officers, employees, agents, representatives, insurers, successors, and assigns from and against any and all claims, demands, charges, complaints, causes of action, fees (including, but not limited to, attorney’s fees and expert witness fees), and other liability arising from, related to, or connected with Contractor’s negligent or wrongful errors or omissions in performing its services. Contractor shall maintain general liability insurance or self-insurance with limits of at least \$2,000,000 per occurrence and \$5,000,000 in the aggregate (including any umbrella insurance), and shall maintain professional liability insurance or self-insurance with limits of at least \$2,000,000 per occurrence and in the aggregate. The Board of Education shall not waive any rights by making payment.

Contractor/Supplier Name: Lauterbach & Amen LLP

By: Todd A. Schwabe
Signature of Officer or Authorized Representative

 Partner in charge of Actuarial Services
Title

Date: 4/28/2023



EXHIBIT
A

February 27, 2023

Members of the Board of Trustees
Lincolnwood School District #74
6950 N East Prairie Road
Lincolnwood, Illinois 60712

We are pleased to confirm our acceptance and understanding of the services we will provide for the Lincolnwood School District #74 for the fiscal years ending June 30, 2024 through June 30, 2025. It is our understanding that Lauterbach & Amen, LLP will prepare the GASB 74/75 Actuarial Valuation for the School District.

You agree to assume all management responsibilities for the actuarial services we provide; you will oversee the services by designating an individual, preferably from senior management, with suitable skill, knowledge, or experience; you will evaluate the adequacy and results of the services and will accept responsibility for them.

Lauterbach & Amen, LLP does not assume any management responsibilities for the School District. These services cannot be relied upon to detect errors, irregularities, or illegal acts that may exist. However, we will inform you of any such matters that may come to our attention.

Costs for our services are as follows:

	Fiscal Year Ended 06/30/2024	Fiscal Year Ended 06/30/2025
Annual Actuarial Reports		
• Preparation of GASB 74/75 Actuarial Valuation*	\$3,890	\$1,020
• Preparation of Audit Friendly Exhibits	Included	Included
Total Annual Actuarial Reports	\$3,890	\$1,020

*All GASB 74/75 reporting will follow a biennial reporting cycle and for all fiscal year ends where a full-valuation is not required, we will prepare financial statement entries based on a limited actuarial report. The limited actuarial report will not require updating of participant or medical information but will be run at the most recently available discount rate required by the GASB 74/75 standards. If, for any reason, the School District or auditors require a full-valuation vs. the limited actuarial report, updating of all participant and medical information will be required and the fee for a full valuation will be charged.

Out of Scope Services:

Out of scope services will be billed on a time and charges basis. The hourly rate for out of scope services is \$275 per hour. We will provide an estimate of costs for any out of scope services when the service is requested and the scope is defined. You will not be charged any additional costs under this section unless written approval, including email confirmation, is provided ahead of time.

Either party may terminate all or a portion of the services contemplated by this engagement at any time for any reason upon 30 days written notice to the other. Subcontracting will be disclosed to the School District's Board of Trustees prior to beginning work. This agreement shall be governed by and construed in accordance with the laws of the State of Illinois.

We appreciate the opportunity to be of service to the Lincolnwood School District #74 and believe this letter accurately summarizes the significant terms of our engagement. If you have any questions, please let us know. If you agree with the terms of our engagement as described in this letter, please indicate your acceptance by signing below and returning it to us.

Cordially,

Lauterbach & Amen, LLP

Lauterbach & Amen, LLP

RESPONSE:

This letter correctly sets forth the understanding of the Lincolnwood School District #74:

Accepted by: _____

Title: _____

EXHIBIT B

[NOTE: Illinois law requires that this statement be included in all Illinois public contracts (See 44 Ill. Adm. Code 750.10)]

The Contractor agrees to fully comply with the requirements of the *Illinois Human Rights Act*, 775 ILCS 5/1-101 *et. seq.*, including, but not limited to, the provision of sexual harassment policies and procedures pursuant to Section 2-105 of the Act. The Contractor further agrees to comply with all federal Equal Employment Opportunity Laws, including, but not limited to, the *Americans With Disabilities Act*, 42 U.S.C. Section 12101 *et. seq.*, and rules and regulations promulgated thereunder. The following provisions are included in this Contract pursuant to the requirements of the regulations of the Illinois Department of Human Rights, Title 44, Part 750, of the Illinois Administrative Code, and Contractor shall be required to comply with these provisions only if and to the extent they are applicable under the law. As required by Illinois law, in the event of the Contractor's non-compliance with the provisions of this Equal Employment Opportunity Clause, the *Illinois Human Rights Act* or the Rules and Regulations of the Illinois Department of Human Rights ("Department"), the Contractor may be declared ineligible for future contracts or subcontracts with the State of Illinois or any of its political subdivisions or municipal corporations, and the contract may be canceled or voided in whole or in part, and such other sanctions or penalties may be imposed or remedies invoked as provided by statute or regulations. During the performance of this contract, the Contractor agrees as follows:

- A. That it will not discriminate against any employee or applicant for employment because of race, color, religion, sex, sexual orientation, marital status, national origin or ancestry, age, citizenship status, physical or mental handicap or disability unrelated to ability, military status or an unfavorable discharge from military service, or arrest record status; and further that it will examine all job classifications to determine if minority persons or women are underutilized and will take appropriate affirmative action to rectify any such underutilization.
- B. That, if it hires additional employees in order to perform this contract or any portion thereof, it will determine the availability (in accordance with the Department's Rules) of minorities and women in the area(s) from which it may reasonably recruit and it will hire for each job classification for which employees are hired in such a way that minorities and women are not underutilized.
- C. That, in all solicitations or advertisements for employees placed by it or on its behalf, it will state that all applicants will be afforded equal opportunity without discrimination because of race, color, religion, sex, sexual orientation, marital status, national origin or ancestry, age, citizenship status, physical or mental handicap or disability unrelated to ability, military status or an unfavorable discharge from military service, or arrest record status.
- D. That it will send to each labor organization or representative of workers with which it has or is bound by a collective bargaining or other agreement or understanding, a notice advising such labor organization or representative of the Contractor's obligation under the *Illinois Human Rights Act* and the Department's Rules. If any such labor organization or representative fails or refuses to cooperate with the Contractor in its efforts to comply with such Act and Rules, the Contractor will promptly so notify the Department and the contracting agency and will recruit employees from other sources when necessary to fulfill its obligation thereunder.
- E. That it will submit reports as required by the Department's Rules, furnish all relevant information as may from time to time be requested by the Department or the contracting agency, and in all respects comply with the *Illinois Human Rights Act* and the Department's Rules.
- F. That it will permit access to all relevant books, records, accounts and work sites by personnel of the contracting agency and the Department for purposes of investigation to ascertain compliance with *Illinois Human Rights Act* and the Department's Rules.
- G. That it will include verbatim or by reference the provisions of this clause in every subcontract it awards under which any portion of the contract obligations are undertaken or assumed, so that such provisions will be binding upon such subcontractor. In the same manner as with other provisions of this contract, the Contractor will be liable for compliance with applicable provisions of this clause by such subcontractors; and further it will promptly notify the contracting agency and the Department in the event any subcontractor fails or refuses to comply therewith. In addition, the Contractor will not utilize any subcontractor declared by the Illinois Human Rights Commission to be ineligible for contracts or subcontracts with the State of Illinois or any of its political subdivisions or municipal corporations.

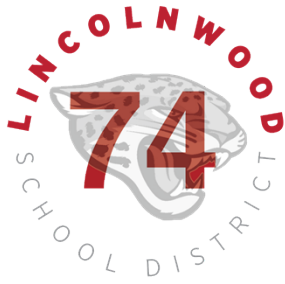

Executive Summary Board of Education Meeting

DATE: June 1, 2023

TOPIC: FY24 Facility Rental Fee Waiver Request from LBSA

PREPARED BY: Courtney Whited

Recommended for:

- Action
- Discussion
- Information

Purpose/Background:

Lincolnwood Baseball and Softball Association (LBSA) has used SD74 facilities and fields for practices and games for several years. LBSA is a Category II organization according to the Facility Rental Policy updated in September 2019. The resulting fees would create an extreme hardship on LBSA. The organization's waiver request is attached.

Fiscal Impact:

Category II fees for the gyms and outdoor fields would not be collected during FY24

Recommendation:

The Finance Committee concurs with the Administration to recommend to the Board of Education to waive facility rental fees during fiscal year 2024 for Lincolnwood Baseball and Softball Association.



PO BOX 46443
Chicago, IL 60646

www.lwbba.org

LBA Board Members

John Dreuth
President

Rick Hoffman
Vice President

Mike Bartholomew
Vice President

David Spitz
Co-Secretary

Carrie Spitz
Co-Secretary

Donna Dreuth
Treasurer

Jeron Dorsey
Village Liaison

Ben Friedman
Director

Joe Osborne
Director

Peter Kougias
Director

Adam Kolovic
Director

Susan Kougias
Director

Eileen Canney Linnehan
Director

Kira Hoffman
Director

Alex Stojanoff
Director

Chris Hutchison
Director

Rich Barnes
Director

Jay Greenberger
Director

Matt Ceisel
Director

April 20, 2023

Lincolnwood School District 74 Board of Education:

Lincolnwood Baseball and Softball Association (LBSA) has used SD74 facilities and fields for many years. LBSA requests that all rental fees continue to be waived in the use of the SD74 facilities and fields.

Sincerely,

A handwritten signature in cursive script that reads "John Dreuth".

John Dreuth
President, LBSA



Executive Summary Board of Education Meeting

DATE: June 1, 2023

TOPIC: BrainPop/BrainPop Jr. Renewal Contract for 2023-2024 School Year

PREPARED BY: Jordan Stephen

Recommended for:

- Action
- Discussion
- Information

Purpose/Background:

Lincolnwood School District 74 has subscribed to BrainPop and BrainPop Jr. since 2011. These subscriptions provide video explanations and activities for students in Kindergarten through 8th Grade, and supports various languages. Teachers use BrainPOP to introduce new topics or reinforce topics dealing with math, reading and writing, science, social studies, health, and arts and technology. Topics available to teachers and students also contain current event topics, and social-emotional learning units. Individual logins are available for students, or teachers can share the content with a whole class. Teachers have the ability to print out materials like quizzes, and students can submit their work for feedback online as well.

District Legal Counsel reviewed the Terms and Conditions and Privacy Policy and found them sufficient. Counsel also indicated that we have a signed Amendment on file, which the vendor has previously agreed to. Currently the District does have an Exhibit E posted online based upon the National Data Privacy Agreement (IL-NDPA) necessitated by the Student Online Personal Protection Act (SOPPA) which is based off of the IL-NDPA from Gurnee School District 56.

Fiscal Impact:

\$8,749.65. The District paid \$7,460.25 for the 2022-23 school year.

Recommendation:

The Finance Committee concurs with the Administration to recommend to the Board of Education to renew the BrainPop and BrainPop Jr. subscription for all students in all grades in the District in the amount of \$8,749.65 from August 12, 2023 to August 11, 2024.

BrainPOP

Issued By Cassie Palisky
 Email cassiep@brainpop.com

Quote PDF (Created 1/27/2023 Date)
 Quote Number 00062998
 Account Name Lincolnwood School District 74

Bill To Name Lincolnwood School District 74
 Bill To 6950 N. EAST PRAIRIE ROAD
 LINCOLNWOOD, IL 60712
 USA

Description Discounts:
 - 5% small district, multi-site

Contact Name Jordan Stephen Email jstephen@sd74.org

Please Note: If the person listed above is not the primary contact for your subscription, please let us know.

Product Name	Quantity	Product Description	Discount	Sales Price	Subtotal
BrainPOP and BrainPOP Jr. Combo (K-8) School Subscription	2.00	School-wide subscription to BrainPOP and BrainPOP Jr. gives you full access to over 1,200 topics across the curriculum, including grade-level movies with Pause Points, quizzes, challenges, and creative learning tools. Also includes access to BrainPOP Español and BrainPOP Français.	5.00%	USD 3,524.63	USD 6,696.80
BrainPOP Jr. (K-3) School Subscription	1.00	School-wide access to BrainPOP Jr. for K-3rd grade classrooms. Foster curiosity for learning and set a foundation for success with our unique content and effective learning tools designed for young learners.	5.00%	USD 2,160.90	USD 2,052.86

Subtotal USD 9,210.16

Discount 5.00%

Grand Total USD 8,749.65



Provisions				
Access Recipient	Product	Access Start Date	Access End Date	Provision Price
Lincoln Hall Middle School	BrainPOP and BrainPOP Jr. Combo (K-8) School Subscription	8/12/2023	8/11/2024	USD 3,348.40
Rutledge Hall Elementary School	BrainPOP and BrainPOP Jr. Combo (K-8) School Subscription	8/12/2023	8/11/2024	USD 3,348.40
Todd Hall Elementary School	BrainPOP Jr. (K-3) School Subscription	8/12/2023	8/11/2024	USD 2,052.86

I accept the purchase of the items included herein. I understand that I will be invoiced for this order.

BrainPOP

Name: _____ Authorized Signature: _____

Title: _____ Date: _____

*Please include any applicable tax exemption certificates for the school/district along with your order.

Quote valid for 90 days. All amounts listed are in USD. This subscription is governed by the Terms of Use and Privacy Policy posted on www.brainpop.com, as amended from time to time. By accepting this quote, you agree to these terms. Changes/modifications to the terms must be approved and signed by an authorized representative of BrainPOP. Terms and conditions submitted with any Purchase Order shall not apply to this subscription. If the Customer has a signed agreement with BrainPOP that is applicable to this subscription, then that agreement will apply.

Remit to BrainPOP Accounts Receivable PO BOX 28119 | New York, NY 10087-8119 | Fax 866-867-6629
Please make all checks payable to 'BrainPOP'. Email: purchaseorders@brainpop.com

Privacy Policy

- We design and operate our technology and services with our users' protection and privacy in mind, and we make every effort to be transparent in our data collection and use practices.
- Our flagship education products include individual accounts that enable schools and parents to keep track of individual student learning and maintain control over their student data.
- We do not use student or children's personal information for advertising purposes, including targeted advertising.
- We do not rent or sell student data.
- BrainPOP uses industry standard protocol to ensure that student data is encrypted and transmitted securely from end to end and at rest.
- We limit the data collected from students or children to only that which is necessary to meet the educational purposes of BrainPOP.
- We do not collect sensitive data like biometric or health data or behavior data.
- Students cannot interact with other users outside their school, classroom or family account. The product is not intended and does not allow for social interactions between students.
- Districts, schools and homeschools are able to delete student personally identifiable information at any time.
- We are proud supporters of the **K-12 School Service Provider Pledge to Safeguard Student Privacy**. (<https://studentprivacypledge.org/privacy-pledge/>)
- We provide prominent notice to users and send out email notices to customers before making any material changes to our Privacy Policy.
- BrainPOP complies with the Children's Online Privacy Protection Act (COPPA).
- BrainPOP agrees to operate as a school official as the term is used in the Family Educational Rights and Privacy Act (FERPA), and operates at the direct control of our school and district customers with respect to our use and handling of their student records.

Privacy Questions? If you have questions or complaints regarding our privacy policy or practices, please contact us at privacy@brainpop.com (<mailto:privacy@brainpop.com>).

Privacy Policy

Last updated June 15th, 2020.

This privacy policy applies to all the BrainPOP and its affiliates ("BrainPOP") owned and operated websites and mobile applications (which we collectively refer to as "Services"). By accessing or using our Services, you agree to the terms of this Privacy Policy.

Definitions

For purposes of this policy, we will use the following definitions:

Personally identifiable information (PII) is information that can identify a user of the Services, including his or her e-mail, name, and address. It also includes PII combined with non-PII.

De-identified information is information from which personally identifiable components have been removed and a reasonable determination made that an individual is not identifiable.

Student Records are records that are directly related to a student and maintained by BrainPOP on behalf of a school or district subscriber.

What Type Of Information Do We Collect And Why?

Education Product Subscribers:

Information collected during the subscription process: During the registration process for any of our subscriptions, we ask the subscriber to provide us with a name, email address, school or district affiliation (when applicable), phone number, and billing information. We may also ask you to provide username and password. We use the information to create and service the account, fulfill the subscription and send you service-related announcements. For instance, we may send emails about routine maintenance, new feature launches or product recommendations related to your subscription. We may also use this contact information to request feedback on our products and services, to inform future customer service and product improvements. If you are registering for a free trial, we will use the information to create a free trial account and to send occasional promotional emails and other marketing campaigns. You may opt out of promotional email messaging at any time as described in the Opt Out section below.

BrainPOP At Schools:

Whether engaging with BrainPOP through a free trial or a paid subscription, schools or districts are required to appoint an administrator (“Administrator”), who is authorized by the school or the district to be responsible for the Students Records.

Each school or district Administrator has access to a dashboard that allows them to create, update, review, modify and delete individual accounts, and monitor logins within the individual accounts.

To create the teacher accounts, we require a full name, email address, class name, and a password security question. We also use the email address to send product updates and use recommendations, password recovery information, effectiveness and efficacy data, invitations to participate in surveys and research and more (messaging may not be available in all jurisdictions). An unsubscribe option is included in promotional messaging.

If a school or district uses and accesses individual accounts through any of the single sign on services that we support, we collect the information we use for the individual accounts function from the third party integrated service.

Students:

Students accounts can be created by the school, the district, or by the teachers, or the teacher can invite the students to create the accounts using a class code provided by the teacher. We collect students' full name, class, graduation year/grade, username, password and security question(s). Students will be able to store their activities, quizzes, movies and other projects they've created and correspondences with their teachers within their individual accounts. We collect student's voice-recording if they use the recording feature in Make-a-Movie®. Students cannot interact with other users outside their school or classroom subscription. Students' PII is not posted publicly.

BrainPOP At Home:

To create a family subscription for home use, parents or legal guardians are asked to provide their full name, email address and other minimally required personal information.

For family subscriptions that permit individual accounts, we also ask parents or guardians for their children's name (first or full name, depending on product), graduation year/grade, username, password and security question(s), an avatar image, when applicable. We use this information to create the individual child accounts. Some of the family subscriptions allow children to store their activities, quizzes, movies and other projects they created, and badges or goals they have achieved, and the Homeschool subscription allows for children to correspond with the parent/guardian within the Services. Children cannot interact with other users outside their family or homeschool subscription. Children PII is not posted publicly.

Parents or guardians subscribing to the family products will receive occasional emails with information about usage of the accounts, new features, product use recommendations, effectiveness and efficacy testing, backup schedules, survey and research participation invitation and more. An opt-out will be included at the bottom of promotional messaging.

Children Under Age 13:

In compliance with the Children's Online Privacy Protection Act (COPPA), BrainPOP does not collect personally identifiable information from children under 13, without a parent or guardian's consent, or that of a school if applicable. Parents and guardians of children under 13 who use any of the BrainPOP products have certain rights under COPPA and BrainPOP recognizes those rights. At any time, parents/guardians using a home product may request to review the personal information we collected from their child, request that we make no further use of that information or request that we delete it. To exercise your right to delete information, please use the contact information below. Parents/guardians of children using BrainPOP through a school account should contact their school to exercise their rights and we will work with the parent/guardian and school together to facilitate those requests.

A child's participation or access to an activity on BrainPOP cannot be conditioned on him or her providing more personal information than is reasonably necessary for that activity.

Connecting With BrainPOP:

Contact information for newsletter and surveys: On BrainPOP Educators®, and other adult-facing pages of our Services, including pages that do not require log in, adult users may choose to sign up for newsletters, promotional offerings, or participation in surveys, all of which require contact information. The submitted contact information will be used for promotional purposes, and you may opt-out at any time. An opt-out link or instructions on how to opt-out will be included at the bottom of such messages. Registration for newsletters, promotional offerings, and surveys participation are not intended for minors.

Information we collect when you contact us: When you send us messages through our system or by email or through other online platforms, we collect the information you provide, including your message and any contact information you include. We use and retain such information to respond to your request, facilitate support to you in the future and to optimize our support services. We will respond once to messages from children under age 13 and then we delete those messages and any personally identifiable information contained in them.

Feedback: Certain features we offer include an option to provide us with feedback. The feedback feature does not identify the user submitting it. If we receive personally identifiable information through a feedback form we take steps to immediately delete that information. We reserve the right to use feedback for any purpose with no obligation to you.

Applying for a job: all resumes submitted by applicants through our website are submitted through BambooHR. We will only use the information for the application process.

Information Collected Automatically

We automatically receive and record information on our server logs from a user's browser. This may include the IP address, pages of BrainPOP visited, the time spent on those pages, and access times and dates. We use this information to better display our Services, maintain a user's session, identify the country the user is located in, monitor, analyze use of and administer BrainPOP, and to better tailor it to your needs. We may also use this information to serve advertising to adult users.

To collect this information, we use technological tools including:

Cookies. A cookie is a small data file sent from a website or application and stored on your computer or device. Cookies allow us to recognize your browser when you return to BrainPOP, remember your login information, enable access to paid content and monitor potential account misuse. Cookies also allow us to better understand how you interact with BrainPOP and to monitor aggregated usage. You can set your browser to detect some cookies, to stop accepting cookies or to prompt you before accepting a cookie. Disabling our cookies will prevent access to paid content and limit some of the functionalities within

our Services. To learn more about browser cookies, including how to manage or delete them, look in the Tools, Help or similar section of your web browser, or visit **allaboutcookies.org** (<http://www.allaboutcookies.org>).

Pixel Tags. A pixel tag (also known as a “clear GIF” or “web beacon”) is a tiny image – typically just one-pixel – that we place in our marketing emails, newsletters, promotional offerings and surveys. We use pixel tags and line tracking to analyze the effectiveness of our marketing campaigns.

We use Google Analytics to assist us in collecting and assessing automatically collected information. For more information about Google Analytics, see **Google Analytics Terms of Service** (<https://policies.google.com/terms>) and the **Google Privacy Policy** (<https://policies.google.com/privacy>). You can prevent Google Analytics from collecting information about you and recognizing you on return visits to our Services by disabling cookies on your browser or by installing the Google Analytics opt-out plug in. Note that we are not responsible for Google’s opt-out tools.

By using our Services, you agree to our use of these tracking technologies.

We do not track users across unaffiliated sites and services, however, when you use the Internet, unaffiliated parties such as ad networks, web analytics companies and social networking platforms may collect information about your online activities over time and across our and other websites. This information may be used to provide advertisements for products and services that may interest you, and those companies may use cookies, clear GIFs and other tracking technologies.

In addition, we and our third party partners may use tracking technologies to deliver targeted advertisements and marketing messages to adult users on our or unaffiliated websites and online services. We also occasionally source information about groups of adults to generate a "lookalike audience" or similar audience of prospective customers through advertising platforms. This allows us to target prospective customers with advertisements on their networks who appear to have shared interests or similar demographics to our existing customers, based on the platforms' own data. We do not have access to the identity of anybody in the lookalike audience, unless they choose to click on the ads, and this information is only used for customer prospecting.

To learn about interest-based advertising, “lookalike audiences” and how you can opt-out of these features, you may wish to visit the Network Advertising Initiative’s online resources, at <http://www.networkadvertising.org/choices> (<http://www.networkadvertising.org/choices>), and/or the Digital Advertising Alliance (DAA) resources at <http://www.aboutads.info/choices> (<http://www.aboutads.info/choices>). Note that if you wish to opt out, you will need to do so separately for each of your devices and for each web browser you use. You may also manage certain advertising cookies by visiting the EU-based Your Online Choices at <http://www.youronlinechoices.eu/> (<http://www.youronlinechoices.eu/>). You may also be able to limit interest-based advertising through the settings on your mobile device by selecting “limit ad tracking” (iOS)

or “opt-out of interest based ads” (Android). You may also be able to opt-out of some – but not all – interest-based ads served by mobile ad networks by visiting <http://youradchoices.com/appchoices> (<http://youradchoices.com/appchoices>) and downloading the mobile AppChoices app.

We also subscribe to various third parties’ education market information and databases, for example databases of school contacts. We use this data to learn about the industry we serve, to improve our services and for direct marketing. Some third-parties may provide us pseudonymized information about you (such as demographic information or sites where you have been shown ads) from offline and online sources that we may use to provide you more relevant and useful advertising.

Push notifications on mobile apps: Our adult users have the option to accept push notifications. If push notifications are accepted, we will store your previously provided name and email address in the push notification token. If you choose to receive push notifications, we will need to collect certain information about your device - such as operating system and user identification information - in order to ensure they are delivered properly. We also collect the user time zone, which is set on the device, to ensure that we send notifications at an appropriate time of the day. We do not combine this information with other PII. You may turn push notifications off at any time using your device controls.

How Long We Retain Personal Information:

Districts, schools and homeschools are able to delete student personally identifiable information at any time and in real time using the Administrator dashboard as mentioned above. Once that information is deleted, it is deleted from our servers – first from our servers and then, after two weeks later, from any back-up server. If information was not deleted by the school or the district before the subscription expired, we retain such information for a limited period of two years after expiration.

Student classroom accounts and the student identifiable information within them are automatically deleted after two years of inactivity - first from our server and then, two weeks later, from any back-up server. At that point it cannot be restored.

If your jurisdiction requires the deletion of student data within a shorter time period, or upon immediate termination of the subscription, you are required to delete such data using the Administrator dashboard as mentioned above or contact us for assistance at legal@brainpop.com (<mailto:legal@brainpop.com>).

Districts and schools may request copies of their student personal information (which includes an CSV template file of names, classes and quiz scores), which shall be provided within four (4) weeks of the written request.

Individual accounts created on the BrainPOP Home subscription will automatically be deleted after three (3) months after the expiration of the subscription.

We will retain, use and share anonymous or aggregate and de-identified information for lawfully permissible purposes, including developing and improving educational products and services, educational research purposes, evaluating, informing and demonstrating the effectiveness and efficacy of our products and services.

How We Share Your Information

We may provide Personally Identifiable Information to our partners, business affiliates, and third party service providers who work for BrainPOP and operate some of its functionalities. These may include hosting, streaming, credit card processing services and companies that provide marketing emails on our behalf. A current list of these third parties service providers is available to our subscribers upon request through **privacy@brainpop.com (mailto:privacy@brainpop.com)**. These third parties service providers are bound contractually to practice commercially reasonable security measures and to use your Personally Identifiable Information solely as it pertains to the provision of their services. They do not have the independent right to share your Personally Identifiable Information or use it for any unrelated purposes.

We reserve the right to disclose personally identifiable information if we are required to do so by law, or if we believe that disclosure is necessary to protect our rights, protect your safety or others' safety, investigate fraud, and/or comply with a judicial proceeding, court order, subpoena, or legal process.

We also reserve the right to transfer your Personally Identifiable Information in case of a corporate restructuring (such as a merger, acquisition or other disposition of our business), as long as the receiving entity adopts this Privacy Policy regarding your information.

We may share teachers', administrators' and parents' email addresses collected when registering to free trials with third parties business partners for marketing purposes when the individual has opted in to receive such communication. You may opt out of promotional messaging at any time as described in the Opt Out section below.

Security

We strive to maintain security policies and procedures that are designed to protect your information.

Our servers are located in a secured, locked, and monitored environment to prevent unauthorized entry or theft, and are protected by a firewall. The servers are located in a data center in the United States and backed up daily to a secure, U.S.-based, off-site data center.

We apply a Secure Sockets Layer (SSL or HTTPS) encrypting technology to encrypt data in transit between the server and the browser remains encrypted. We also encrypt the data at rest.

Governance policies and access controls are in place to ensure that the information of each district, school, or other subscriber is separated, and all subscribers can only access their own data.

Only limited BrainPOP personnel have access to the database, and personnel only access it when necessary to provide services. Personnel with access to Student Records pass criminal background checks and undergo periodic privacy training.

We follow standardized and documented procedures for coding, configuration management, patch installation, and change management for all applicable servers, and we have a third party audit our practices at least once a year.

While we strive to maintain industry-standard privacy and security practices, it should be noted that no industry system is fail proof, and we are not responsible for security incidents not reasonably foreseeable or reasonably within our control. In the event of unauthorized access to Personally Identifiable Information, we will notify the affected subscriber(s) in accordance with applicable law, and as appropriate, coordinate with the subscriber to support notification of affected individuals, students, and families.

Links To Third Party Sites

While using our Services, you may be referred to or linked from or to third party sites, such as educational partners whose games are included on our GameUp® portal. While we contractually require our third parties partners to adhere to our privacy policies, you should keep in mind that once you leave BrainPOP and visit a third party site, our privacy policy is no longer in effect. We are not responsible for information, content, terms of use, or privacy policies on these other sites. By browsing and interacting with any other website, you are subject to that website's own rules and policies. Please read those rules and policies carefully before proceeding. Please also keep in mind that you do have the option to block third party links. To do so, please contact our support team at **privacy@brainpop.com (mailto:privacy@brainpop.com)**.

Social Networks:

Adult facing pages within our Services contain social network sharing plug ins or widgets. These plugins may provide information to their associated social networks or third-parties about your interactions with our web pages that you visit, even if you do not click on or otherwise interact with the plug-in or widget. Information is transmitted from your browser and may include an identifier assigned by the social network or third party, information about your browser type, operating system, device type, IP address, and the URL of the web page where widget appears. If you use social network tools or visit social networking websites, you should read their privacy disclosures, to learn what information they collect, use, and share. We are not responsible for information, content, terms of use, or privacy policies at these social networks or third party sites.

Opt Out

If you have subscribed to receive marketing messaging from us, or if you receive an unwanted email from us, you can opt-out of receiving future emails by clicking the opt-out link in the email or alternatively by sending an email to **legal@brainpop.com** (**mailto:legal@brainpop.com**), with “Opt out” in the subject line. We will process your request within a reasonable time after receipt. Note that you will continue to receive operational emails regarding the products or services you are subscribed to.

For California Residents

As a California resident, you have certain rights regarding your personal information. These rights include:

- **Right to Know and Access Information:** You may request access to the personal information we maintain about you in the ordinary course of business. This may include what personal information we collect, use, or disclose about you. We may not fulfill some or all of your request to access as permitted by applicable law.
- **Right to Deletion:** You may request that we delete your personal information. Depending on the scope of your request, we may refrain from granting your request, as permitted by applicable law. For example, we may be legally required to retain your information in our business records.
- **Right to Opt Out of the Sale of Your Personal Information:** California law considers certain uses of personal information, such as sharing your personal information with a third party in order to serve ads to you to be a “sale.” We do not sell personal information of children or students. However we do engage in some marketing behavior with data from adults that would be considered a “sale” under California law. You may request to opt-out of that use of your information by using the methods provided below or via **this form. (mailto:legal@brainpop.com?subject=Do Not Sell My Info)**

In order to prevent unauthorized access to your information, we are required by law to verify your identity before we may address your request.

To Exercise Your Rights

BrainPOP is used in schools at the direction of our Customers. In addition, we are obligated under FERPA to remain under the direct control of our Customers with respect to our use and maintenance of student personal information that is part of the education record. As such, if you use BrainPOP through a school account and wish to exercise your rights in respect to student personal information, please contact your education institution and we will work with them to facilitate your request.

All other BrainPOP users and visitors may exercise these rights by:

- Calling us at Toll free phone number: ~~866-54-BRAIN~~¹²² (866-542-7246)

- Emailing us at legal@brainpop.com (<mailto:legal@brainpop.com>)
- Visiting <https://educators.brainpop.com/contact-us/contact-legal/> (<https://educators.brainpop.com/contact-us/contact-legal/>)
- Or mailing us at BrainPOP, Attn: Legal Department, 71 W 23rd Street, 17th Floor, New York, NY 10010.

Your exercise of the above rights is subject to certain exemptions to safeguard the public interest and our interests. Requests to exercise these rights may be granted in whole, in part, or not at all, depending on the scope and nature of the request and applicable law. Where required by applicable law, we will notify you if and why we are unable to fulfill your request.

Non-discrimination: We shall not discriminate or otherwise penalize anyone for exercising their rights.

<p>Categories of Personal information we collect</p>	<ul style="list-style-type: none"> • Identifiers such as a real name, unique personal identifier, online identifier, Internet Protocol address, email address, billing address, and phone number. Your name, address, phone number and billing information may also considered personal information under subdivision (e) of California Business and Professions Code Section 1798.80 • Internet or other electronic network activity information regarding your interaction with BrainPOP • Geolocation information in the form of your country • Education information, defined as information that is not publicly available personally identifiable information as defined in the Family Educational Rights and Privacy Act (20 U.S.C. section 1232g, 34 C.F.R. Part 99). <p>For adult users, we also collect:</p> <ul style="list-style-type: none"> • Commercial information, including records of products or services purchased, obtained, or considered, or other purchasing or consuming histories or tendencies. • Internet or other electronic network activity information, including, but not limited to, browsing history, search history, and information regarding a consumer’s interaction with an Internet Web site, application, or advertisement.
--	--

<p>Categories of sources from which the Personal Information is collected</p>	<ul style="list-style-type: none"> • We collect Personal Information directly from the Customer, teacher and from student users. • We also collect Personal Information about adult users and customer prospects from third parties' education market information and databases, for example databases of school contacts. • We collect this information directly from you, from our business partners and affiliates, from your browser or device when you visit our websites, or from third parties that you permit to share information with us.
<p>Business or commercial purpose for collecting or selling Personal Information</p>	<p>We collect your Personal Information to provide the services and for the following business purposes:</p> <ul style="list-style-type: none"> • Performing services in accordance with our contract with the Customer and the terms of use including maintaining or servicing accounts, providing customer service, processing or fulfilling orders and transactions, verifying customer information, and processing payments. • Detecting security incidents, protecting against malicious, deceptive, fraudulent, or illegal activity, and prosecuting those responsible for that activity. • Debugging to identify and repair errors that impair existing intended functionality. • Sending you product communications.
<p>Categories of third parties with whom we share Personal Information</p>	<p>We share personal information with service providers who support us in delivering the Services as described above.</p> <p>For our adult users, we also share personal information with "third parties" as the term is defined in CCPA for targeted marketing purposes.</p>

<p>Specific pieces of Personal Information we have collected</p>	<p>Education Products Subscribers:</p> <p>Administrators, educators and parents: full name, email address, phone number, username, password, security question, school, school address (or home if parents), classes associated with the account, IP address</p> <p>Students: full name, username, password, security question, school and classes associated with the account, graduation year/grade, voice recording (if using Make-a-Movie recording feature), IP address</p> <p>Connecting with BrainPOP: name, email address, other contact information, IP address</p> <p>Website visitors: IP address, pseudonymous end user identifiers</p>
--	---

Authorized Agent: California residents may use an authorized agent on their behalf to exercise a privacy right discussed above. If you are an authorized agent acting on behalf of a California resident to communicate with us or to exercise a privacy right discussed above, you must be able to demonstrate that you have the requisite authorization to act on behalf of the resident and have sufficient access to their laptop, desktop, or mobile device to exercise these rights digitally. If you are an authorized agent trying to exercise rights on behalf of a BrainPOP user, please contact the user's school or district with supporting verification information, which includes a valid Power of Attorney in the State of California, proof that you have access to the user's device, and proof of your own identity.

Using BrainPOP® Outside The US

If you are using the Services outside the United States, you consent to having your information and data transferred to the United States. If you are in any jurisdiction with laws or regulations governing internet use, including collection, use, and disclosure of personal data, different from those of the United States, you may only use the Services in a manner that is lawful in your jurisdiction. If your use of the Services may be unlawful in your jurisdiction, please do not use them. If your use of the individual accounts may be unlawful in your jurisdiction, please do not use it.

Using BrainPOP® From The EU

BrainPOP processes your information in one of two capacities, either: (i) as a Data Controller for our own internal business operations, such as sales, marketing, administration etc., or (ii) as a Data Processor when carrying out our Services for our school customers using individual accounts.

As a Data Controller, BrainPOP processes your personal data, in accordance with applicable law, for the following purposes:

- a. track your interaction with our emails we send, so we can see if they are working as intended;
- b. sending you marketing communications/placing marketing calls, in order to keep you informed of our products and services, which we consider may be of interest to you;
- c. to comply with applicable law, for example, in response to a request from a court or regulatory body, where such request is made in accordance with the law; and
- d. where necessary for the establishment, exercise or defence of legal claims, whether in court proceedings or in an administrative or out-of-court procedure; and
- e. offer our goods to you in a personalized way, for example, we may provide suggestions based on your personal data to enable you to identify suitable goods and services.

The bases for processing of your personal data for the purposes described above will include:

- you provided us with your consent;
- for BrainPOP's legitimate business interests as outlined in paragraphs a., b. (where this does not include B2C email or phone marketing communications), d. and e. above; or
- for compliance with a legal or statutory obligation to which BrainPOP is subject.

Your personal data will be retained as long as is reasonably necessary for the purposes listed above or as required by applicable local law. Retention periods can vary based on the type of information and how it is used.

What Are Your Rights Under the GDPR?

Parents/guardians of children using BrainPOP through a school account should contact their school to exercise their rights and we will work with the parent/guardian and school together to facilitate those requests.

When we are operating as a Controller, we provide you with certain rights related to your personal data. To exercise your rights, please contact us at **accessrequests@brainpop.com** (**<mailto:accessrequests@brainpop.com>**). We will respond to your request within a reasonable time frame.

Please note that the rules in your country may provide you with additional rights or may limit the rights noted below. In all cases, we will comply with the applicable laws.

Right of access

You may have the right to obtain confirmation about whether or we process your personal data, and when we do, to request access to that personal data. The access information includes the purposes of processing, the categories of personal data involved, and the

recipients or categories of recipients to whom the personal data have been or will be disclosed. However, this is not an absolute right and the interests of other individuals may restrict your right of access.

You may have the right to obtain a copy of the personal data undergoing processing. For further copies requested by you, we may charge a reasonable fee based on administrative costs.

Right to rectification

You may have the right to rectify inaccurate personal data concerning you. Depending on the purposes of the processing, you may have the right to have incomplete personal data completed, including by means of providing a supplementary statement.

Right to erasure

Under certain circumstances, you may have the right to obtain from us the erasure of personal data concerning you and we may be obliged to erase that personal data.

Right to restriction of processing

Under certain circumstances, you may have the right to restrict processing your personal data. In this case, the respective data will be marked and may only be processed by us for certain purposes.

Right to data portability

Under certain circumstances, you may have the right to receive the personal data concerning you, which you have provided to us, in a structured, commonly used and machine-readable format and you may have the right to transmit those data to another entity without hindrance from us.

Right to object

Under certain circumstances, you may have the right to object, on grounds relating to your particular situation, or where Personal Data are processed for direct marketing purposes at any time to the processing of your Personal Data by us and we can be required to no longer process your Personal Data.

Moreover, if your Personal Data is processed for direct marketing purposes, you have the right to object at any time to the processing of Personal Data concerning you for such marketing, which includes profiling to the extent that it is related to such direct marketing. In this case your Personal Data will no longer be processed for such purposes by us.

If you have concerns or complaints you may have a right to lodge a complaint with a supervisory authority.

To request execution of the Standard Contractual Clauses (“SCC”) as set forth under GDPR regarding the collection, use, and retention of personal information from European Union, Switzerland, and the United Kingdom to the United States, please contact us at

privacy@brainpop.com (mailto:privacy@brainpop.com).

EU-US Privacy Shield

BrainPOP LLC participates in and has certified its compliance with the EU-U.S. Privacy Shield Framework. BrainPOP is committed to subjecting all personal data received from European Union (EU) member countries, in reliance on the Privacy Shield Framework, to the Framework's applicable Principles. To learn more about the Privacy Shield Framework and to view our certification, visit the U.S. Department of Commerce's Privacy Shield website.

<https://www.privacyshield.gov/list> (<https://www.privacyshield.gov/list>)

BrainPOP is responsible for the processing of personal data it receives, under the Privacy Shield Framework, and subsequently transfers it to a third party acting as an agent on its behalf. BrainPOP complies with the Privacy Shield Principles for all onward transfers of personal data from the EU, including the onward transfer liability provisions.

With respect to personal data received or transferred pursuant to the Privacy Shield Framework, BrainPOP's adherence to the Privacy Shield Framework is subject to the regulatory enforcement powers of the U.S. Federal Trade Commission. In certain situations, BrainPOP may be required to disclose personal data in response to lawful requests by public authorities, including requests to meet national security or law enforcement requirements.

Under certain conditions, more fully described on the Privacy Shield website

<https://www.privacyshield.gov> (<https://www.privacyshield.gov>), you may invoke binding arbitration when other dispute resolution procedures have been exhausted.

In compliance with the Privacy Shield Principles, BrainPOP commits to resolve complaints about our collection or use of your personal information. EU individuals with inquiries or complaints regarding our Privacy Shield policy should first contact BrainPOP at:

legal@brainpop.com (<mailto:legal@brainpop.com>).

BrainPOP has further committed to refer unresolved Privacy Shield complaints to TrustArc Privacy Dispute Resolution service, an alternative dispute resolution provider located in the United States. If you do not receive timely acknowledgment of your complaint from us, or if we have not addressed your complaint to your satisfaction, please visit **<https://feedback-form.truste.com/watchdog/request> (<https://feedback-form.truste.com/watchdog/request>)** for more information or to file a complaint. The services of TrustArc are provided at no cost to you.

Using BrainPOP® From Australia

We encourage schools in Australia to use our privacy notice

https://www.brainpop.com/about/australia_notice

https://www.brainpop.com/about/australia_notice) to inform parents/guardians of our products and practices. This notice conforms to the notice requirements under the Australian Privacy Principles (APPs) 8 – cross-border disclosure of personal information.

Privacy question? If you have any questions, comments or complaints about our collection, use or disclosure of your information, or if you believe that we have not complied with this privacy policy or the Privacy Act 1988 (Cth), you can contact us at **accessrequests@brainpop.com** (**<mailto:accessrequests@brainpop.com>**). If you are not satisfied with the outcome of our assessment of your complaint, you may wish to contact the Office of the Australian Information Commissioner.

Changes To Our Privacy Policy

Changes to this policy or any of the pages linked in this policy may be required in order to address changing technology and threats, changing laws, or as we release new or amended services. Should we make material changes to this Privacy Policy, we will provide notice and request your consent. In the event of any non-material changes, we will provide prominent notice as required by law. Posting the modified privacy policy on our Services and providing notice as stated above will give effect to the revised Privacy Policy. Your continued use of the Services constitutes your acceptance of any revised Privacy Policy. If you do not agree to the revised Privacy Policy, please refrain from using the Services and/or leave this website(s) or app(s).

Contact Information

If you have any questions or concerns about this Privacy Policy, please contact us by either:

- Email at **privacy@brainpop.com** (**<mailto:privacy@brainpop.com>**)
- Mail at BrainPOP, Attn: Legal Department, 71 W 23rd Street, 17th Floor, New York, NY 10010.
- Toll free phone number: 866-54-BRAIN (866-542-7246)
- Message through **[here](https://educators.brainpop.com/contact-us/contact-legal/)** (**<https://educators.brainpop.com/contact-us/contact-legal/>**)

If you wish to report a security breach, please contact us at **security@brainpop.com** (**<mailto:security@brainpop.com>**).

Please click on this link to view the previous version of our Privacy Policy, in effect before June 15, 2020. (**https://www.brainpop.com/about/privacy_policy_may2020/**)

Translations

The Privacy Policy is also available in **Spanish** (**<https://esp.brainpop.com/nosotros/politicadeprivacidad/>**), **French** (**https://fr.brainpop.com/about/politique_confidentialite/**), and **Mandarin** (**<https://go.brainpop.com/PrivacyPolicy/CN>**). Please note that the English version shall prevail in the case of any conflict between them.

Visit +

Subscribe +

About +

© 1999–2022 BrainPOP. All rights reserved.

Terms of Use (https://www.brainpop.com/about/terms_of_use/) |

Privacy (https://www.brainpop.com/about/privacy_policy/) |

Trademarks and Copyrights (<https://www.brainpop.com/about/trademarks/>) |

Accessibility (<https://www.brainpop.com/accessibility/>) |

Site Map (<https://www.brainpop.com/site-map/>) |

Do Not Sell My Personal Information (https://www.brainpop.com/about/privacy_policy/#california-residents)

Terms of Use

Last updated on June 15, 2020

Welcome to BrainPOP®!

The use of any of the BrainPOP and its affiliates (“BrainPOP”) owned and operated websites and/or mobile applications (Collectively referred to as “Services”), whether accessed via computer, mobile device or otherwise, is subject to these terms and conditions (“Terms of Use”). Your use of the Services constitutes your agreement to the Terms of Use, so please read them carefully. Additional terms and conditions may apply to some services offered on this Website if we post such terms within such services or if we signed a separate agreement with you for such services. Please contact legal@brainpop.com (**mailto:legal@brainpop.com**) if you have any questions about these Terms of Use.

MINORS: SOME PORTIONS OF THE SERVICES ARE NOT INTENDED FOR MINORS, INCLUDING BRAINPOP EDUCATORS, THE ABOUT BRAINPOP PAGE AND THE STORE. ALSO, REGISTERING AN ACCOUNT REQUIRES SUPERVISION OF A PARENT OR LEGAL GUARDIAN IF YOU ARE A MINOR.

EDUCATORS: IF YOU ARE AN EDUCATOR, WHETHER IN A PUBLIC OR PRIVATE SCHOOL OR EDUCATIONAL ORGANIZATION, THEN, YOU ARE REPRESENTING AND WARRANTING TO US THAT YOU ARE AUTHORIZED TO AGREE TO THESE TERMS OF USE ON BEHALF OF YOUR ORGANIZATION AND YOUR STUDENTS.

The services are operated by BrainPOP LLC and its related companies (“we,” “us”). If you have any questions concerning our Services or the respective operator(s), you may contact us at the following address:

BrainPOP

71 W 23rd St., 17th Fl.

New York, NY 10010

Phone: 212.574.6000

Email: legal@brainpop.com (**mailto:legal@brainpop.com**)

CHANGES TO OUR SERVICES

In our sole discretion and without prior notice or liability, we may discontinue, modify or alter any aspect of the Services and suspend, discontinue, delete, modify, or remove any content or functionality offered in the Services from time to time. In addition, in the future, we may charge users for certain content or functionality which may be presently available for free.

PRIVACY POLICY

Please review our **privacy policy** (https://www.brainpop.com/about/privacy_policy/) ("Privacy Policy"), which is incorporated into, and considered part of, these Terms of Use. The Privacy Policy explains our privacy practices for the Services. By visiting our Services, you also consent to our Privacy Policy, so please read them carefully.

OWNERSHIP

Subject to the provisions of these Terms of Use, the Services and all of its subdomains, contents, links, software (whether downloadable or non-downloadable), interfaces, chat rooms, forums, mobile products, applications, services found on our websites, technology, user interfaces, profiles, widgets, messages, links, emails, graphics, images, video, code, sounds, music, games, videos, User Content (as further explained and defined below), Applications (as defined below) all audio visual or other material appearing on or emanating to and/or from our Services, as well as the design and appearance of our Services and the accompanying information and documentation (collectively, "the Content"), are owned by or licensed to us, subject to copyright, trademark and other intellectual property rights under United States and foreign laws and international conventions. We reserve all rights to the Content.

All product, brand and company names and logos used on the Services are the trademarks or registered trademarks (including, but not limited to the registered trademark "BrainPOP") of their respective owners. Any use of any of the marks appearing on the Services, whether or not owned and/or operated by us is strictly prohibited (unless you first receive our express written consent or the consent of the owner of the mark, as appropriate).

You may not use metatags or any other "hidden text" utilizing "BrainPOP" or any other name, trademark, service mark or product or service name of BrainPOP without our prior written permission. In addition, the look and feel of the Services, including all page headers, custom graphics, button icons and scripts, is the service mark, trademark and/or trade dress of BrainPOP and may not be copied, imitated or used, in whole or in part, without our prior written permission. Reference to any products, services, processes or other information, by trade name, trademark, manufacturer, supplier or otherwise does not constitute or imply endorsement, sponsorship or recommendation thereof by us.

ACCESS TO THE SERVICES AND LICENSE TO USE

Unless there is a prior written agreement between you and us stating otherwise, we grant you a limited, personal, non-exclusive, non-sublicensable, non-transferable, non-commercial, revocable license to access and make personal use of the Services based on the applicable subscription you purchased ("Use License"). If you are an educator, the Use

License includes permission to use the Services for educational use within the classroom or the school of your students. This Use License is subject to your full compliance with these Terms of Use.

The Use License does not allow you to: (i) download (other than as necessary for page viewing) or modify the Services or the Content, or any portion thereof, except with our express prior written consent; (ii) reproduce, distribute, duplicate, republish, copy, sell, resell or otherwise exploit or make any commercial use of the Services or the Content; (iii) collect and use any of our offerings, product listings, descriptions or pricing thereof or otherwise attempt to or download and/or copy user account information for benefit of another or in violation of the Use License; (iv) make any derivative use of the Services or the Content; (v) use any data mining or reverse engineering tools, spiders, robots, or similar data gathering and extraction tools; (vi) frame or utilize framing techniques or caches to enclose any trademark, logo, or other proprietary information (including images, text, page layout, or form) located on the Services, including that of BrainPOP.

Notwithstanding the above, certain Content is made available for download or printing (such as Activities, Printed Quizzes and FYI pages). You may print or download the page, file or the available material, as applicable, solely for your personal, non-commercial use subject to the Use License. If you are an educator printing or downloading material with Student's Records (as defined below), you may only use it for educational use within the classroom or the school of the student, and you are solely responsible to obtain parents' or guardians' permissions for your use, if required. The download or print function is not intended for any other function.

Any unauthorized use of the Services or violation of these Terms of Use and the Use License automatically terminates your permission to use the Services.

THE CONTENT; SUBMISSION OF USER CONTENT AND USE OF OUR SERVICES

CONTENT

We attempt to provide accurate descriptions of the Content. However, we do not warrant that product descriptions or other parts of the Content are accurate, complete, reliable, current, or error-free. If Content is materially misrepresented, your sole remedy is to cease use of that Content and to notify us of the purported error.

While using our Services, you may be referred to or linked from or to third party sites, such as educational partners whose games are included on our GameUp portal. Users should keep in mind that once they leave BrainPOP and visit a third party site, our privacy policy is no longer in effect. We are not responsible for information, content, terms of use, or privacy policies on these other sites. By browsing and interacting with any other website, you are subject to that website's own rules and policies. Please read those rules and policies

carefully before proceeding. Please also keep in mind that you do have the option to block third party links. To do so, please contact our support team at privacy@brainpop.com (<mailto:privacy@brainpop.com>).

Adult-facing pages of our Services websites may also provide links to social plugins and third party sites that have separate privacy policies and procedures; by clicking through to them, you are subject to their rules and policies. The use of these social media plugins is optional and leads to user-generated content. We are not responsible for information, content, terms of use, or privacy policies at these social networks or third party sites.

We expressly disclaim any and all liability in connection with your use of any features or content provided by third parties. Any such use of third party content is at your own risk and may subject you to additional or different terms and restrictions by the third party running the service.

EMBEDDED CONTENT FROM OUR SERVICES

Our Services may provide you with an “Embedded Features” option that enables you to incorporate certain Content into your own personal, non-commercial websites for use in accessing the materials on our Services (“Embedding”). Your use of Embedding, is subject to these Terms of Use, in all respect, including, but not limited to limitations imposed by the Use License. You must provide a prominent link back to our Services on all pages containing the Embedded Features. Please note that all of the limitations and restrictions and all of the terms included in these Terms of Use apply to the use of this feature. We reserve the right to revoke the license to use the Embedded Features for any reason in our sole discretion and without providing you with explanations or clarifications. You agree to remove the Embedded Features from our Services immediately upon request from us.

USER CONTENT

Student Records:

Student Records are records that are directly related to a student and maintained by BrainPOP on behalf of a school or district subscriber. Each school or district has access to a user-friendly administrator dashboard that allows direct control over the Student Records at all times. The administrator(s) appointed by the school or district can create, update, review, modify, and delete individual accounts, and monitor logins within the individual accounts. We will solely use the Student Records for the purpose of providing and enhancing teacher and student use of the Services.

For more information about Student Records, see our **Privacy Policy** (https://www.brainpop.com/about/privacy_policy).

Other User Content:

Certain functionalities within adult-facing pages of our Services may allow you to submit, upload, post, or create (collectively “submit”) certain types of content (“User Content”). Except for Student Records as defined in our Privacy Policy, you acknowledge and agree that we do not guarantee any confidentiality with respect to any User Content you submit. You shall retain all ownership rights to and shall be solely responsible for your own User Content and the consequences of submitting and publishing such User Content. You affirm, represent, and warrant that you own or have the necessary licenses, rights, consents, and permissions to create and publish any User Content you submit. You may not upload or post any User Content on our Services that infringes the copyright, trademark or other intellectual property rights of a third party nor may you upload User Content that violates any third party's right of privacy or right of publicity. You may upload only User Content that you are permitted to upload by the owner or by law.

By submitting any User Content other than Student Records as defined in our Privacy Policy, you grant us a worldwide, perpetual, non-exclusive, royalty-free, sub-licensable and freely transferable license to use, publish, reproduce, distribute, disseminate, copy, prepare derivative works of, and display, in whole or in part, the User Content, without additional approval or consideration, in any form, media, or technology now known or later developed for the full term of any rights that may exist in such User Content, and you hereby waive any claim to the contrary. You acknowledge and agree that such User Content may be utilized by our users in various ways over which we do not have any control and you expressly release us from any claims with respect to any use of User Content by any third parties.

We do not endorse any User Content submitted to our Services and expressly disclaim any and all liability in connection with such User Content. We reserve the right to remove or modify any User Content in any manner, at any time and without prior notice. If you find any inappropriate Content on our Services, we encourage you to report such inappropriate content to: legal@brainpop.com (<mailto:legal@brainpop.com>).

USER CONTENT RESTRICTIONS

We strictly prohibit the use of our Services for offensive, illegal or harming purposes. You agree not to use our Services (i) to create, edit, post or share any content that is harmful, unlawful, obscene, libelous, racist, hateful, or criminal or that violates the privacy of others, or any other illegal, offensive or inappropriate content, or (ii) for purposes that are illegal, obscene, threatening, defamatory, invasive of privacy, infringing of intellectual property rights, or otherwise objectionable, as determined in our sole and absolute discretion.

You further agree not to use our Services in a manner that (i) is unlawful, fraudulent, deceptive, or impersonates any person or entity; (ii) uses technology or other means to access unauthorized content or non-public spaces or reverse engineer any functionalities of our Services; (iii) uses any type of automated system or process, including without limitation, “bots,” “spiders,” or “crawlers,” to access unauthorized content or non-public spaces; (iv) introduces or attempts to introduce viruses or any other harmful computer code

or programs that interrupt, destroy or limit the functionality of our Services or related servers and networks; (v) attempts to gain unauthorized access to our Service's users' accounts; (vi) constitutes a criminal offense or otherwise encourages criminal conduct; (vii) gives rise to civil liability; (viii) violates these Terms of Use in any manner; (ix) fails to comply with the Terms of Use applicable to Third Party Content; or (x) uses our Services for creating, sharing and sending unsolicited commercial messages.

Display of User Content on our Services does not constitute our approval or endorsement thereof. We reserve the right to remove any content that we deem to be illegal, offensive or inappropriate, in our sole discretion, and we reserve the right to take action against the user submitting such User Content, including, but not limited to, suspending any or all use of our Services, in any way or manner, or terminating such user's account.

USER ACCOUNT

Certain content and functionalities of the Services require registration in order to be able to enjoy such content and functionalities. We reserve the right to decide which content and functionalities require registration or will require registration in the future. You are responsible for maintaining the confidentiality of your account and password and for restricting access to your computer, and you agree to accept responsibility for all activities that occur under your account or password. You agree to notify us immediately in the event of any known or suspected unauthorized use of your user account, or any known or suspected breach of security, including loss, theft, or unauthorized disclosure of your or anyone else's password. You are entirely responsible for any and all activities which occur under your user account. You agree to immediately notify us of any unauthorized use of your user account or any other breach of security known to you.

If you provide any information that is untrue, inaccurate, or incomplete (including but not limited to falsely self-identifying), or we have reasonable grounds to suspect that such is the case, we reserve the right to suspend or terminate your user account and refuse any and all current or future use of our Services.

In the course of the registration process to certain features or products in our Services, you may be entitled to upload a profile picture to your account. The profile picture you upload may not contain nudity, obscenity, sexually explicit material or contain images of people which have not given you a prior written permission to use their image.

STUDENT ACCOUNTS

Our individual accounts system allows you to create student accounts. If you are an educator, you warrant and represent that you are authorized to use our Services with your students on behalf of your school and/or district.

If you are a school, a district or an educator using the individual accounts on behalf of your students, including in a free trial, you warrant and represent that you are authorized to act on parents'/guardians' behalf or that you have obtained consent from parents or guardians of your students in accordance to the laws governing your jurisdiction.

APPLICATIONS

Our Services may allow you to download certain applications to be used on mobile devices, such as smartphones or tablets (“Application” or “Applications”). The download and use of the Applications is governed by these Terms of Use and by any Terms of Use applicable to the Applications at the time you download onto your mobile device (“Mobile Terms of Use”). Any conflicts between these Terms of Use and the Mobile Terms of Use with respect to Applications shall be resolved in favor of the Mobile Terms of Use.

If you are downloading or accessing an Application via an application store operated by a third party (for example, App Store®), you acknowledge that such third party is not a party to and has not agreed to these Terms of Use or, otherwise, does not sponsor, endorse or have any affiliation with our Services. Your download of Applications through such third parties is subject to their respective terms of use (e.g. App Store® usage rules)

We may charge a fee for downloading the Applications that will be disclosed to you prior to you downloading the Applications. These fees are subject to change. In the event that we change the fees charged for the Applications, we will not provide any type of price protection, refunds or promotional pricing for any reason. Use of the Applications may be subject to standard messaging, data and other fees that may be charged by your mobile carrier. Your carrier may also prohibit or restrict the Applications and the Applications may be incompatible with your carrier or mobile device. If you have any questions concerning this, please contact your carrier to obtain further information.

Please note that our Applications are not available if your school is using a single sign on service.

COPYRIGHT POLICY AND COMPLAINTS

We respect the intellectual property of others. If you believe that any material on our Services infringes upon any copyright that you own or control, please send us a notification of such infringement containing the following information:

1. An electronic or physical signature of the person authorized to act on behalf of the owner of the copyright or other intellectual property interest;
2. A description of the copyrighted work or other intellectual property that you claim has been infringed;

3. A description of where the material that you claim is infringing can be found on our Services;
4. Your address, telephone number, and email address;
5. A statement that you believe that the disputed use is not authorized by the copyright owner, its agent, or the law; and
6. A statement by you at the bottom of your notification exactly as follows: **“I hereby declare, under penalty of perjury, that the above information is accurate and that I am the copyright or intellectual property owner or authorized to act on behalf of the copyright or intellectual property owner.”**

Send the notification to us as follows:

BrainPOP

71 W 23rd St., 17th Fl.

New York, NY 10010

Phone: 212.574.6000

Email: legal@brainpop.com (mailto:legal@brainpop.com)

In accordance with the Digital Millennium Copyright Act and other applicable laws, we have adopted a policy of terminating accounts and/or pursuing other remedies, at our sole discretion, if we suspect that the account holder has infringed the intellectual property rights of BrainPOP or any third party.

DISCLAIMER OF WARRANTIES AND LIMITATION OF LIABILITY

THE SERVICES INCLUDING THE CONTENT AND ALL INFORMATION, MATERIALS, PRODUCTS AND SERVICES INCLUDED ON OR OTHERWISE MADE AVAILABLE TO YOU ARE PROVIDED BY US ON AN "AS IS" AND "AS AVAILABLE" BASIS, UNLESS OTHERWISE SPECIFIED IN WRITING. WE MAKE NO REPRESENTATIONS OR WARRANTIES OF ANY KIND, EXPRESS OR IMPLIED, AS TO THE OPERATION OF THE SERVICES OR THE CONTENT, INFORMATION, MATERIALS, PRODUCTS OR SERVICES INCLUDED ON OR OTHERWISE MADE AVAILABLE THROUGH THE SERVICE, UNLESS OTHERWISE SPECIFIED IN WRITING. YOU EXPRESSLY AGREE THAT YOUR USE OF THE SERVICES IS AT YOUR SOLE RISK.

TO THE FULL EXTENT PERMISSIBLE BY APPLICABLE LAW, WE DISCLAIM ALL WARRANTIES, EXPRESS OR IMPLIED, INCLUDING, BUT NOT LIMITED TO, IMPLIED WARRANTIES OF MERCHANTABILITY AND FITNESS FOR A PARTICULAR PURPOSE. WE DO NOT WARRANT THAT THE SERVICES, THE CONTENT, INFORMATION, MATERIALS, PRODUCTS OR SERVICES INCLUDED ON OR OTHERWISE MADE AVAILABLE THROUGH THE SERVICES IS FREE OF VIRUSES OR OTHER HARMFUL COMPONENTS. IN NO EVENT SHALL WE OR ANY OF OUR AFFILIATES, SUPPLIERS OR THEIR RESPECTIVE MEMBERS,

DIRECTORS, OFFICERS, EMPLOYEES, SHAREHOLDERS, PARTNERS OR AGENTS BE LIABLE FOR ANY INCIDENTAL, INDIRECT, PUNITIVE, EXEMPLARY, OR CONSEQUENTIAL DAMAGES WHATSOEVER (INCLUDING, WITHOUT LIMITATION, DAMAGES FOR LOSS OF PROFITS, BUSINESS INTERRUPTION, LOSS OF BUSINESS INFORMATION, OR ANY OTHER PECUNIARY LOSS) ARISING FROM THE USE OF THE SERVICES OR FROM THE CONTENT, INFORMATION, MATERIALS, PRODUCTS OR SERVICES INCLUDED ON OR OTHERWISE MADE AVAILABLE THROUGH THE SERVICES, WHETHER THE DAMAGES ARISE FROM USE OR MISUSE OR RELIANCE OR INABILITY TO USE THE SERVICES OR ANY OF THE CONTENT, INFORMATION, MATERIALS, PRODUCTS OR SERVICES INCLUDED ON OR OTHERWISE MADE AVAILABLE THROUGH THE SERVICES, OR WHETHER THEY ARISE FROM THE INTERRUPTION, SUSPENSION, MODIFICATION, ALTERATION, OR TERMINATION OF ANY SERVICES OR ANY CONTENT, INFORMATION, MATERIALS, PRODUCTS OR SERVICES INCLUDED ON OR OTHERWISE MADE AVAILABLE THROUGH THE SERVICES. IN NO EVENT SHALL OUR TOTAL MAXIMUM AGGREGATE LIABILITY UNDER THESE TERMS EXCEED THE AMOUNT ACTUALLY PAID, IF ANY, TO US BY THE INJURED PARTY. IN ANY JURISDICTION THAT DOES NOT ALLOW FOR THE LIMITATION OR EXCLUSION OF LIABILITY FOR INCIDENTAL OR CONSEQUENTIAL DAMAGES OR FOR A TOTAL MAXIMUM AMOUNT, OUR LIABILITY OR LIABILITY OF ANY OF OUR MEMBERS, DIRECTORS, OFFICERS, EMPLOYEES, SHAREHOLDERS, PARTNERS, AFFILIATES, AGENTS, SUPPLIERS, CUSTOMERS OR LICENSEES SHALL BE LIMITED TO THE MAXIMUM EXTENT PERMITTED BY LAW.

INDEMNITY

You agree to indemnify, hold us harmless and, at our option, defend us and our affiliates, and our officers, directors, employees, stockholders, agents and representatives from any and all third party claims, liability, damages and/or costs (including, but not limited to, reasonable attorneys' fees and expenses) arising from your improper use of the Services or our products or offerings, your violation of these Terms of Use, or your infringement, or the infringement or use by any other user of your account, of any intellectual property or other right of any person or entity. We reserve the right, at your expense, to assume the exclusive defense and control of any matter otherwise subject to indemnification by you, and in such case, you agree to cooperate with our defense of such claim.

TERMINATION

You may stop using our Services at any time and at your sole discretion, with no need for justification and with no charge, and you may contact us and request to delete your account and/or disable your subscription. Note that the termination of an account or a subscription

does not delete the information posted by you, and you may need to contact us directly to request editing, deletion or removal of such information. If your account is terminated, your rights to use our Services will cease immediately.

WAIVER

Any waiver of any provision of the Terms of Use will be effective only if in writing and signed by the waiving party.

DISPUTES AND APPLICABLE LAW

You agree that the laws of the State of New York, without regard to principles of conflicts of laws, will govern these Terms of Use and any dispute of any sort that might arise between you and us. Any dispute relating to or arising from your use of the Services shall be solely adjudicated in the Supreme Court of the State of New York or in the U.S. Federal District Court located in New York County, New York, and you consent and submit to exclusive jurisdiction and venue in such courts and agree to accept service of process by electronic mail.

Without derogating from the above, any claim that you may have in connection with these Terms of Use must first, and before taking any other legal action, be submitted to us in the form of a complaint to **legal@brainpop.com (mailto:legal@brainpop.com)** to enable the parties to resolve the claim in a friendly and effective manner. If the parties fail to resolve the claim in this manner in a reasonable timetable, or if any other claim or dispute in connection with these terms arises, it shall be resolved in the exclusive jurisdiction and venue as specified above. Notwithstanding the foregoing, we may seek injunctive or other equitable relief to protect our intellectual property rights in any court of competent jurisdiction at any time.

CHANGES AND SEVERABILITY

You agree to check the Terms of Use periodically for new information and terms that govern your use of our Services. We reserve the right to make changes to our Services, our policies, and these Terms of Use at any time. Posting the modified Terms of Use on our Services will give effect to the revised terms. Your continued use of our Services indicates your acceptance of any revised terms. If you do not agree to the revised terms, stop using our Services immediately. If any of the terms or conditions in these Terms of Use shall be deemed invalid, void, or for any reason unenforceable, that condition shall be deemed severable and shall not affect the validity and enforceability of any remaining condition.

COMMUNICATION WITH US

You agree to receive communications from us electronically regarding your account, these Terms of Use and the Services, and such communications sent from us shall be considered sufficient means of notice, whether applicable law requires written notice or not. You further agree that your electronic communications, except for communications regarding subscriptions, are not confidential.

Please click on this link to view the previous version of our Terms of Use, in effect before June 15, 2020. (https://www.brainpop.com/about/terms_of_use_may2020/)

Translations

These Terms of Use are also available in **Spanish** (<https://esp.brainpop.com/nosotros/terminosdeuso/>), **French** (https://fr.brainpop.com/about/conditions_utilisation/), and **Mandarin** (<https://go.brainpop.com/TermsOfUse/CN>). Please note that the English version shall prevail in the case of any conflict between them.

Visit	+
<hr/>	
Subscribe	+
<hr/>	
About	+
<hr/>	

© 1999–2022 BrainPOP. All rights reserved.

Terms of Use (https://www.brainpop.com/about/terms_of_use/) |

Privacy (https://www.brainpop.com/about/privacy_policy/) |

Trademarks and Copyrights (<https://www.brainpop.com/about/trademarks/>) |

Accessibility (<https://www.brainpop.com/accessibility/>) |

Site Map (<https://www.brainpop.com/site-map/>) |

Do Not Sell My Personal Information (https://www.brainpop.com/about/privacy_policy/#california-residents)



Executive Summary Board of Education Meeting

DATE: June 1, 2023

TOPIC: 2023-2024 Encyclopedia Britannica Renewal

PREPARED BY: Jordan Stephen

Recommended for:

- Action
- Discussion
- Information

Purpose/Background:

Encyclopedia Britannica is a curricular tool that is available online to all students in the District. The resources found through this service meet the unique needs of every learner as students can toggle between three reading levels on each article, have articles read aloud, and use Merriam-Webster's dictionary to hear words pronounced and read their definitions. Each article can also be translated into over 80 languages. For every search, information pulled from Britannica School appears on the right side of the screen, ensuring that students are learning from a reliable and fact-checked source. Based upon usage statistics, this product is being used widely across the District.

District Legal Counsel has reviewed this Terms and Quote for Encyclopedia Britannica Renewal and found it acceptable. Counsel noted that SOPPA does not apply to this vendor as no student data is transmitted or stored.

Fiscal Impact:

\$715.00 for the use of Britannica School Subscription for all students and teachers in the school District. (The District paid Encyclopedia Britannica \$977.50 in 2022-2023)

Recommendation:

The Finance Committee concurs with the Administration to recommend to the Board of Education to approve the Britannica School Subscription Contract in the amount of \$715 from July 1, 2023 to June 30, 2024.



Quote #: Q-68483-1
 Date: 2/1/2023 4:00 PM
 PO #: PENDING PO
 Expires On:
 Prepared By: Lillian Terry
 Email: lterry@eb.com

Quotation

Encyclopaedia Britannica
 325 N. LaSalle St. Suite 200, Chicago, Illinois 60654
 Phone: (800) 621-3900 Fax: (800) 344-9624

Quote To
 Jordan Stephen
 LINCOLNWOOD SCH DIST 74
 ADMINISTRATION BLDG
 6950 EAST PRAIRIE ROAD
 LINCOLNWOOD, Illinois 60712
 United States
 Jordan Stephen
 847-675-8234
 jstephen@sd74.org

Bill To
 Accounts Payable
 LINCOLNWOOD SCH DIST 74
 ADMINISTRATION BLDG
 6950 EAST PRAIRIE ROAD
 LINCOLNWOOD, Illinois 60712
 United States

Sold To

Comments: Formal Quote for Renewal 23-24

Subscription Terms

Starting Date: 7/1/2023
 Ending Date: 6/30/2024
 Term: 12

Total Users: 0
 Weighted Users: 0

Product	Product Code	Total Price
Britannica School Subscription	OLSV-Britannica School Subscription	USD 715.00
TOTAL:		USD 715.00

ACH Payments:
 Encyclopaedia Britannica, Inc.
 Account # 2462513
 Routing/ABA # 071000288
 Type: Checking
 Currency: US Dollar

Lillian G. Terry

 LILLIAN G. TERRY

 SR ACCOUNT EXECUTIVE

 02-01-2023

To pay with credit card, please email ebcustomerserv@eb.com

Terms & Conditions

Tax Id: 36-2063569
 Please return a copy of this invoice with payment to:
 ENCYCLOPAEDIA BRITANNICA, INC.
 P.O. BOX 95225
 CHICAGO, IL 60694-5225

Please Note: Unless specified tax is not included on this invoice.

ENCYCLOPAEDIA BRITANNICA, INC.

**Britannica Education Solutions
Online Terms of Use**

Effective Date: June 9, 2021

Updated: August 17, 2021

These Terms of Use govern your use of Encyclopaedia Britannica, Inc.'s ("Britannica") Britannica Education reference and curriculum solutions to which your institution subscribes (collectively, the "Services").

THESE TERMS OF USE CONTAIN DISCLAIMERS OF WARRANTIES AND LIABILITY, A CHOICE OF LAW CLAUSE, AND A CLASS ACTION WAIVER. THESE PROVISIONS AFFECT YOUR RIGHTS ABOUT HOW TO RESOLVE ANY DISPUTE WITH BRITANNICA. PLEASE READ THEM CAREFULLY BEFORE USING THE SERVICES.

For information on how Britannica collects, uses and shares any personal information, please see our [Privacy Notice](#). If you reside outside of the European Economic Area, your acceptance of these Terms of Service constitutes your consent to the processing activities described in our [Privacy Notice](#) under the laws of your jurisdiction.

SECTION 1

Agreement to Terms of Use

Your use of the Services constitutes your agreement to these Terms of Use. If you do not agree with these Terms of Use, please do not use the Services. Britannica reserves the right to change, modify, add, or remove portions of these Terms of Use at any time, and the modified Terms of Use will be effective when posted on the Services. Please check this page periodically for any modifications. Your use of any of the Services following the posting of changes constitutes your acceptance of the changes.

Ownership. The content on the Services is the property of Britannica, its affiliated companies or licensors, and is protected by international copyright, patent, and trademark laws. All materials published or available on the Services (including, but not limited to text, photographs, images, illustrations, designs, audio clips, video clips, "look and feel," metadata, data, or compilations, all also known as the "Content") are protected by copyright, and owned or controlled by Britannica, its affiliated companies or licensors, or the party credited as the provider of the Content. Britannica also owns copyright in the selection, coordination, compilation, and enhancement of such Content ("Arrangement"). You shall abide by all additional copyright notices, information, or restrictions contained in any Content accessed through the Services.

Use of Content. You may display, reproduce, print or download content on the Services only for your personal, non-commercial use. If you are a teacher, scholar or student, you may copy

reasonable portions of the content for lesson plans, interactive whiteboards, reports, dissertations, presentations, school newspapers and for similar nonprofit educational purposes to the extent permitted by applicable law. In each case, however, you may not remove or alter any copyright, trademark, service mark or other proprietary notices or legends. You may not publish, distribute, retransmit, sell or provide access to the content on the Services, except as permitted under applicable law or as described in these Terms of Use. Britannica works to ensure that all the content on its Services complies with applicable U.S. copyright laws. However, in the case of works on the Services authored by parties other than Britannica, you may wish to check on their copyright status before downloading them if you are in another country. You may not use data mining, robots, screen scraping, or similar data gathering and extraction tools on the Services, except with our express written permission. You may not decompile, reverse engineer or disassemble any software or other products or processes accessible through the Services, insert any code or product, or manipulate the content of the Services in any way that affects the user's experience.

If you want to reproduce or use content for any purpose or in any manner other than as described above, you will need Britannica's permission. Requests should be directed to edsupport@eb.com.

Use of Images. ImageQuest™ subscribers may use any image included on the [ImageQuest™](#) Web site for non-commercial (not for sale), educational purposes only, and in accordance with these Terms of Use or as otherwise permitted in writing by Britannica. Educational purposes include: education, teaching, distance learning, private study, retrieving information and research.

User Generated Content. This section applies to the extent we have enabled posting of user-submitted comments, audio, video, text or other materials in the Services or otherwise allow you to send information or materials through the Services (collectively, "UGC").

You are responsible for your own UGC and are responsible for the consequences of sending it through the Services. You must not do the following things: send or post UGC that is copyrighted, unless you are the copyright owner or have the permission of the copyright owner to post it; send or post UGC that reveals trade secrets, unless you own them or have the permission of the owner; send or post UGC that infringes on any other intellectual property rights of others or on the privacy or publicity rights of others or is otherwise unlawful; send or post UGC that is obscene, defamatory, threatening, harassing, abusive, hateful or embarrassing to any other person or entity; send or post a sexually-explicit image; send or post advertisements or solicitations of business; send or post chain letters or the like; or impersonate another person.

By sending or posting UGC, you warrant and represent that you own or otherwise control all of the rights to the content and use of your UGC by Britannica will not infringe or violate the rights of any third party. By sending UGC, you automatically grant to Britannica, a royalty-free, perpetual, irrevocable, non-exclusive license to use, reproduce, modify, publish, edit, translate,

distribute, perform, and display it alone or as part of other works in any form, media, or technology whether now known or hereafter developed, and to sublicense such rights through multiple tiers of sublicensees. You retain the right to reuse your UGC as submitted to Britannica.

You may not use the Services or other communication mechanisms to sell, to trade, or for other commercial purposes. You may not send UGC through the Services that violates the rights of any third party or contains a virus or other harmful component. Nor may you use language or engage in any activity that is threatening, abusive, vulgar, discourteous, disruptive, or unlawful.

Please be aware that once you post UGC, there is the potential for the general public to read your words, even years from now. Britannica suggests that you exercise caution when posting UGC on the Services and that you not disclose personal identifiable information like your location, medical record number, financial information, etc.

The opinions and/or views expressed in UGC represent the thoughts of individuals, and not those necessarily of Britannica or any of its affiliated companies or any of their respective directors, officers, attorneys, employees, or members of its board of directors. Accordingly, notwithstanding anything else in these Terms of Use, Britannica should not be seen as endorsing any UGC in any way. Britannica, its affiliated companies, any of their respective directors, officers, attorneys, employees, and/or members of its board of directors shall not be liable for any UGC posted or sent by users of the Services.

Britannica does not have any obligation to monitor, edit or delete UGC, but may do so in its sole discretion. UGC including, but not limited to, the following may be deleted or edited by Britannica:

- Abusive or hurtful UGC about a commentor or another participant;
- Off-topic and redundant UGC (this includes promotion of events, groups, pages, Web sites, organizations and programs not related to or affiliated with Britannica);
- UGC that uses foul or hateful language;
- Personal attacks or defamatory statements or comments;
- UGC that violate the privacy of our users;
- UGC that is obscene, threatening, harassing, deceptive or fraudulent;
- UGC directed at children under the age of 13;
- UGC that may infringe any patent, trademark, trade secret, copyright, or other intellectual or proprietary right of any party or individual; and
- UGC that violates applicable laws or regulations.

By submitting UGC, you understand and acknowledge that this information is available to the public, and that we may use this information for internal and external promotional purposes. Please note that other visitors of the Services may use your posted UGC beyond the control of Britannica. If you do not wish to have the UGC you have made available via the Services used, published, copied and/or reprinted, please do not post UGC on the Services.

Linking to the Services. For details on how to link to the Services, please email edsupport@eb.com. Please contact Britannica when you link to the Services, so that Britannica can better understand how its content is being accessed and so that you can be contacted when changes are made to the Services that could invalidate your links. Any linking to the Services will be at your own risk and expense.

By linking to the Services, you agree that you will not:

- imply in any way, by manner of presentation of the link or otherwise, that Britannica endorses your site, products or services, or that you are affiliated with Britannica in any way;
- frame Britannica content, surround it with your own advertising or identity, or charge a fee for any link to the Services;
- link to the Services from any Web page or Web site containing libelous, obscene or criminal material, or material that infringes, violates, or advocates the infringement or violation of any third party rights; or
- host, publish, broadcast, rewrite or redistribute any content on the Services except as permitted in these Terms of Use or as specifically permitted by Britannica.

Mobile Application Services. You may download certain mobile applications from either Britannica Web sites or third party app stores. All of these Terms of Use, including our Privacy Policy, apply to the maximum extent relevant to your use of such Britannica mobile applications. Prices for our mobile applications may change at any time, and we do not provide price protection or refunds in the event of a price reduction or promotional offering.

Use of your Data. Please see our [Privacy Policy](#) for details about how we use and process the data we collect from our Services.

Service-Specific Terms. Some of our Services include additional, Service-specific terms that govern your use of the Service in question. Please click here to view our Service-specific terms. If you do not agree with the Service-specific terms, please do not use the Service in question.

Idea Submission Policy. I recognize that Britannica is always innovating and working on ideas, products, processes, and technologies for use in new and existing products. For this reason, Britannica does not accept or consider unsolicited ideas, including without limitation ideas for new or improved products, creative works, marketing plans, or product names (collectively, "Ideas"). Please do not submit any unsolicited Ideas in any form to Britannica. If, despite our request that you not send us Ideas, you still submit an Idea, then regardless of what you say in your submission, the following terms shall apply: You agree that:

- Your Idea and its contents will automatically become the property of Britannica without any compensation of any kind owed to me by Britannica or any of its affiliates. Britannica may redistribute your Idea and its contents for any purpose and in any way.

- Neither Britannica nor any of its affiliates is obligated to keep confidential your Idea or any of the information that you submit to us. You agree and acknowledge that all Ideas and information submitted by you will be treated as non-confidential information.
- Britannica does not have any obligation to evaluate your Idea.

Disclaimer of Warranties. THE SERVICES AND ALL INFORMATION, PRODUCTS, AND OTHER CONTENT INCLUDED IN OR ACCESSIBLE FROM THE SERVICES ARE PROVIDED "AS IS" AND WITHOUT WARRANTIES OF ANY KIND (EXPRESS, IMPLIED, AND STATUTORY, INCLUDING BUT NOT LIMITED TO THE IMPLIED WARRANTIES OF MERCHANTABILITY AND FITNESS FOR A PARTICULAR PURPOSE), ALL OF WHICH BRITANNICA EXPRESSLY DISCLAIMS TO THE FULLEST EXTENT PERMITTED BY LAW.

Limitation of Liability. IN NO EVENT SHALL BRITANNICA, ITS DIRECTORS, OFFICERS, SHAREHOLDERS, PARENTS, SUBSIDIARIES, AFFILIATES, AGENTS AND LICENSORS, OR CONTENT PROVIDERS BE LIABLE TO YOU: (i) FOR ANY INDIRECT, SPECIAL, INCIDENTAL, PUNITIVE, OR CONSEQUENTIAL DAMAGES ARISING OUT OF OR RELATED TO THE USE, INABILITY TO USE, PERFORMANCE OR NONPERFORMANCE OF THE SERVICES, EVEN IF BRITANNICA WAS PREVIOUSLY ADVISED OF THE POSSIBILITY OF SUCH DAMAGES AND REGARDLESS OF WHETHER SUCH DAMAGES ARISE IN CONTRACT, TORT, UNDER STATUTE, IN EQUITY, AT LAW, OR OTHERWISE; AND (ii) FOR ANY DAMAGES, LOSSES AND/OR CAUSES OF ACTION EXCEEDING ONE THOUSAND U.S. DOLLARS (US \$1,000) IN THE AGGREGATE.

SOME JURISDICTIONS DO NOT ALLOW LIMITATIONS ON IMPLIED WARRANTIES OR THE EXCLUSION OR LIMITATION OF CERTAIN DAMAGES, SO SOME OF THE ABOVE LIMITATIONS AND EXCLUSIONS MAY NOT APPLY TO YOU.

Indemnification. To the fullest extent permitted by law, you agree to indemnify and hold Britannica, its directors, officers, shareholders, parents, subsidiaries, affiliates, agents, and licensors harmless from and against all losses, expenses, damages, and costs, including reasonable attorneys' fees, arising out of (i) the information or material you submit, including, but not limited to, liability for violations of copyrights, trademark rights, trade secret rights, or any other intellectual property rights, or the privacy or publicity rights of others, or liability for information or material you provide that is obscene, defamatory, threatening, harassing, abusive, hateful or embarrassing to any other person or entity, or is fraudulent or deceptive, (ii) your use or unauthorized copying of the Services or any of their content, or (iii) your violation of these Terms of Use or any applicable laws or regulations.

Governing Law. You agree that all matters relating to your access to or use of the Services and these Terms of Use, including all disputes, will be governed by the laws of the United States and the State of Delaware, without giving effect to any principles of conflicts of laws, including the United Nations Convention on Contracts for the International Sale of Goods.

Class Action Waiver. YOU AND BRITANNICA AGREE THAT EACH PARTY MAY BRING DISPUTES AGAINST THE OTHER PARTY ONLY IN AN INDIVIDUAL CAPACITY, AND NOT AS A PLAINTIFF OR

CLASS MEMBER IN ANY PURPORTED CLASS OR REPRESENTATIVE PROCEEDING, INCLUDING, WITHOUT LIMITATION, A FEDERAL OR STATE CLASS ACTION LAWSUIT. NEITHER YOU NOR BRITANNICA WILL SEEK TO HAVE ANY DISPUTE HEARD AS A CLASS ACTION, PRIVATE ATTORNEY GENERAL ACTION, OR IN ANY OTHER PROCEEDING IN WHICH EITHER PARTY ACTS OR PROPOSES TO ACT IN A REPRESENTATIVE CAPACITY. Nothing in this paragraph limits your right or Britannica’s right to bring a lawsuit against each other as an individual plaintiff.

Claims or Disputes Must be Filed within One Year. To the extent permitted by law, any claim or dispute arising out of or related to use of the Services or these Terms of Use must be filed within one year after such claim or dispute arose. The one-year period begins when the notice of such claim or dispute first could be filed. If such a claim or dispute is not filed within one year, it shall be permanently barred. Any claim by you that may arise in connection with these Terms of Use will be compensable by monetary damages and you will in no event be entitled to injunctive or other equitable relief.

Not Advice. Information contained in the Services is not intended to be medical, legal, tax, financial or other advice and should not be considered medical, legal, tax, financial or other advice, nor is it intended to replace consultation with a qualified physician, attorney or other professional.

Severability. If any provision of these Terms of Use shall be unlawful, void or for any reason unenforceable, then that provision shall be deemed severable from these Terms of Use and shall not affect the validity and enforceability of any remaining provisions.

Survival. The provisions of these Terms of Use which by their nature should survive the termination of these Terms of Use shall survive such termination.

Waiver. No waiver of any provision of these Terms of Use shall be deemed a further or continuing waiver of such provision or any other provision, and your or our failure to assert any right or provision under these Terms of Use shall not constitute a waiver of such right or provision.

Entire Agreement. These Terms of Use constitute the entire agreement between Britannica and you, superseding any prior or contemporaneous communications and proposals (whether oral, written or electronic).

SECTION 2

Legal Notices

Copyrights

All contents of the Services are © Encyclopædia Britannica, Inc. or its licensors. All rights reserved. Encyclopædia Britannica is copyrighted 1994-2022 by Encyclopædia Britannica, Inc.

The 1997, 1998, 1999, 2000, 2001, 2002, 2003, 2004, 2005, 2006, 2007, 2008, 2009, 2010, 2011, 2012, 2013, 2014, 2015, 2016, 2017, and 2018 Britannica Books of the Year are copyrighted 1998, 1999, 2000, 2001, 2002, 2003, 2004, 2005, 2006, 2007, 2008, 2009, 2010, 2011, 2012, 2013, 2014, 2015, 2016, 2017, 2018, and 2019 respectively, by Encyclopædia Britannica, Inc.

Britannica claims no compilation copyright in images or materials that are subject to the GNU Free Documentation License or similar licenses.

Merriam-Webster's Collegiate® Dictionary (Eleventh Edition), Merriam-Webster's Online Dictionary, and Merriam's Webster's Student Dictionary (Third Edition), are all copyrighted by Merriam-Webster, Incorporated.

Photographs and illustrations are copyrighted by their respective owners, as noted in the credits.

Trademarks

"Encyclopædia Britannica" and other marks that appear throughout the Services belong to Encyclopædia Britannica, Inc., its affiliates, or third-party trademark owners.

Google Drive™ is a trademark of Google Inc. Use of this trademark is subject to [Google Permissions](#).

Except as permitted by applicable laws, you are prohibited from using any of the marks appearing on the Services without express written consent from Britannica or the respective trademark owners.

Copyright Infringement Claims

If you believe that any copyright infringement exists on any of the Services, please use the following process to notify Britannica. We will act expeditiously to remove infringing material once informed. All claims of copyright infringement should be in writing and should be directed to our Designated Agent below:

Carmen E. Pagán, Copyright Manager
Encyclopædia Britannica, Inc.
325 North LaSalle Street, Suite 200
Chicago, Illinois 60654
Fax: 312/294-2118
Phone: 312/347-7000
E-mail: copyrightnotice@eb.com

Your notice must contain the following information:

1. Your physical or electronic signature (as either the owner of an exclusive right that is allegedly infringed or as a person authorized to act on behalf of such owner).
2. Identification of the copyrighted work claimed to have been infringed or, if multiple copyrighted works at a single online site are covered by a single claim, a representative list of such works at that online site.
3. Identification of the material that is claimed to be infringing or to be the subject of infringing activity and that is to be removed or access to which is to be disabled and information reasonably sufficient to permit Britannica to locate the material.
4. Information reasonably sufficient to permit Britannica to contact you, such as an address, telephone number and, if available, an electronic mail address.
5. A statement that you believe in good faith that use of the material in the manner complained of is not authorized by the copyright owner, its agent or the law.
6. A statement that the information in the notice is accurate and that, under penalty of perjury, you are the owner of an exclusive right that is allegedly infringed or are authorized to act on behalf of such owner.

Britannica has a policy of terminating in appropriate circumstances the subscriptions of users who are infringers of copyrights held by others. If your material is removed or access to it is disabled and you believe in good faith that a claim has been wrongly made against you, you may submit a counter-notification to Britannica. Your counter-notification must be in writing and sent to:

Carmen E. Pagán, Copyright Manager
Encyclopædia Britannica, Inc.
325 North LaSalle Street, Suite 200
Chicago, Illinois 60654
Fax: 312/294-2118
Phone: 312/347-7000
E-mail: copyrightnotice@eb.com

Your counter-notification must contain the following information:

1. Your physical or electronic signature.
2. Identification of the material that has been removed or to which access has been disabled and the location at which the material appeared before it was removed or access to it was disabled.
3. A statement under penalty of perjury that you have a good faith belief that the material was removed or disabled as a result of mistake or misidentification of the material to be removed or disabled.
4. Your name, address, and telephone number, and a statement that you consent to the jurisdiction of Federal District Court for the judicial district in which you are located, or if you are outside of the United States, for any judicial district in which Britannica may be found, and that you will accept service of process from the person who notified Britannica of the alleged infringement or an agent of such person.

ONLINE SERVICES USAGE AGREEMENT ("TERMS OF USE")
For All Britannica Sites, Services and Applications
Advertising-Supported and Subscription, Consumer and Institutional

Last Updated: June 9, 2021

These Terms of Use govern your use of Encyclopædia Britannica® Online and, unless other terms and conditions expressly govern, any other electronic services, including mobile application services, provided by or made available through Encyclopædia Britannica, Inc., and its affiliates Encyclopædia Britannica (UK) Ltd., Encyclopædia Britannica Australia Ltd., Britannica Asia Pacific Pty Ltd., and Merriam-Webster, Inc. (collectively, "Britannica") that may be available from time to time (collectively, the "Services").

Your use of the Services constitutes your agreement to these Terms of Use. If you do not agree with these Terms of Use, please do not use the Services. Britannica reserves the right to change, modify, add, or remove portions of these Terms of Use at any time, and the modified Terms of Use will be effective when posted on the Services. Please check this page periodically for any modifications. Your use of any of the Services following the posting of changes constitutes your acceptance of the changes.

THESE TERMS OF USE CONTAIN DISCLAIMERS OF WARRANTIES AND LIABILITY, A CHOICE OF LAW CLAUSE, AND A CLASS ACTION WAIVER. THESE PROVISIONS AFFECT YOUR RIGHTS ABOUT HOW TO RESOLVE ANY DISPUTE WITH BRITANNICA. PLEASE READ THEM.

Britannica offers three types of access to its Services: (1) advertising-supported; (2) individual and family consumer subscriptions; and (3) institutional subscriptions. [Section 1](#) of these Terms of Use applies to all individuals who use our Services – advertising-supported and subscription-based. [Section 2](#) applies only to individuals with consumer subscriptions. [Section 3](#) applies only to individuals who are Authorized Users under institutional subscriptions. [Section 4](#) – Service-Specific Terms – applies only to users of a particular Service. [Section 5](#) - Legal Notices – applies to everyone. These Terms of Use also incorporate the terms contained in our [Privacy Policy](#), so please read.

SECTION 1
Terms of Use for Everyone

Ownership. The content on the Services is the property of Britannica, its affiliated companies or licensors, and is protected by international copyright, patent, and trademark laws.

Advertising. Advertisements, promotions, and marketing messages may appear on the Services from time to time, unless you or your institution has a subscription-based Service. Please see our [Privacy Policy](#) for more information.

Use of Content. You may display, reproduce, print or download content on the Services only for your personal, non-commercial use. If you are a teacher, scholar or student, you may copy reasonable portions of the content for lesson plans, interactive whiteboards, reports, dissertations, presentations, school newspapers and for similar nonprofit educational purposes to the extent permitted by applicable law. In each case, however, you may not remove or alter any copyright, trademark, service mark or other proprietary notices or legends. You may not publish, distribute, retransmit, sell or provide access to the content on the Services, except as permitted under applicable law or as described in these Terms of Use. Britannica works to ensure that all the content on its Services is in compliance with applicable U.S. copyright laws. However, in the case of works on the Services authored by parties other than Britannica, you may wish to check on their copyright status before downloading them if you are in another country. You may not use data mining, robots, screen scraping, or similar data gathering and extraction tools on the Services, except with our express written permission. You may not decompile, reverse engineer or disassemble any software or other products or processes accessible through the Services, insert any code or product, or manipulate the content of the Services in any way that affects the user's experience.

If you want to reproduce or use content for any purpose or in any manner other than as described above, you will need Britannica's permission. Requests should be directed to [this syndication form](#).

Use of Images. ImageQuest™ subscribers may use any image included on the [ImageQuest™](#) Web site for non-commercial (not for sale), educational purposes only, and in accordance with these Terms of Use or as otherwise permitted in writing by Britannica. Educational purposes include: education, teaching, distance learning, private study, retrieving information and research.

User Generated Content. This section applies to the extent we have enabled posting of user-submitted comments, audio, video, text or other materials in the Services or otherwise allow you to send information or materials through the Services (collectively, “UGC”).

You are responsible for your own UGC and are responsible for the consequences of sending it through the Services. You must not do the following things: send or post UGC that is copyrighted, unless you are the copyright owner or have the permission of the copyright owner to post it; send or post UGC that reveals trade secrets, unless you own them or have the permission of the owner; send or post UGC that infringes on any other intellectual property rights of others or on the privacy or publicity rights of others or is otherwise unlawful; send or post UGC that is obscene, defamatory, threatening, harassing, abusive, hateful or embarrassing to any other person or entity; send or post a sexually-explicit image; send or post advertisements or solicitations of business; send or post chain letters or the like; or impersonate another person.

By sending or posting UGC, you warrant and represent that you own or otherwise control all of the rights to the content and use of your UGC by Britannica will not infringe or violate the rights of any third party. By sending UGC, you automatically grant to Britannica, a royalty-free, perpetual, irrevocable, non-exclusive license to use, reproduce, modify, publish, edit, translate, distribute, perform, and display it alone or as part of other works in any form, media, or technology whether now known or hereafter developed, and to sublicense such rights through multiple tiers of sublicensees. You retain the right to reuse your UGC as submitted to Britannica.

You may not use the Services or other communication mechanisms to sell, to trade, or for other commercial purposes. You may not send UGC through the Services that violates the rights of any third party or contains a virus or other harmful component. Nor may you use language or engage in any activity that is threatening, abusive, vulgar, discourteous, disruptive, or unlawful.

Please be aware that once you post UGC, there is the potential for the general public to read your words, even years from now. Britannica suggests that you exercise caution when posting UGC on the Services and that you not disclose personal identifiable information like your location, medical record number, financial information, etc.

The opinions and/or views expressed in UGC represent the thoughts of individuals, and not those necessarily of Britannica or any of its affiliated companies or any of their respective directors, officers, attorneys, employees, or members of its board of directors. Accordingly, notwithstanding anything else in these Terms of Use, Britannica should not be seen as endorsing any UGC in any way. Britannica, its affiliated companies, any of their respective directors, officers, attorneys, employees, and/or members of its board of directors shall not be liable for any UGC posted or sent by users of the Services.

Britannica does not have any obligation to monitor, edit or delete UGC, but may do so in its sole discretion. UGC including, but not limited to, the following may be deleted or edited by Britannica:

- Abusive or hurtful UGC about a commentator or another participant;
- Off-topic and redundant UGC (this includes promotion of events, groups, pages, Web sites, organizations and programs not related to or affiliated with Britannica);
- UGC that uses foul or hateful language;
- Personal attacks or defamatory statements or comments;
- UGC that violate the privacy of our users;
- UGC that is obscene, threatening, harassing, deceptive or fraudulent;
- UGC directed at children under the age of 13;
- UGC that may infringe any patent, trademark, trade secret, copyright, or other intellectual or proprietary right of any party or individual;
- and
- UGC that violates applicable laws or regulations.

By submitting UGC, you understand and acknowledge that this information is available to the public, and that we may use this information for internal and external promotional purposes. Please note that other visitors of the Services may use your posted UGC beyond the control of Britannica. If you do not wish to have the UGC you have made available via the Services used, published, copied and/or reprinted, please do not post UGC on the Services.

Linking to the Services. For details on how to link to the Services, [click here](#). Please contact Britannica when you link to the Services, so that Britannica can better understand how its content is being accessed and so that you can be contacted when changes are made to the Services that could invalidate your links. Any linking to the Services will be at your own risk and expense.

By linking to the Services, you agree that you will not:

- imply in any way, by manner of presentation of the link or otherwise, that Britannica endorses your site, products or services, or that you are affiliated with Britannica in any way;
- frame Britannica content, surround it with your own advertising or identity, or charge a fee for any link to the Services;
- link to the Services from any Web page or Web site containing libelous, obscene or criminal material, or material that infringes, violates, or advocates the infringement or violation of any third party rights; or
- host, publish, broadcast, rewrite or redistribute any content on the Services except as permitted in these Terms of Use or as specifically permitted by Britannica.

Mobile Application Services. You may download certain mobile applications from either Britannica Web sites or third party app stores. All of these Terms of Use, including our [Privacy Policy](#), apply to the maximum extent relevant to your use of such Britannica mobile applications. Prices for our mobile applications may change at any time, and we do not provide price protection or refunds in the event of a price reduction or promotional offering.

Use of your Data. Please see our [Privacy Policy](#) for details about how we use and process the data we collect from our Services.

Service-Specific Terms. Some of our Services include additional, Service-specific terms that govern your use of the Service in question. Please [click here](#) to view our Service-specific terms. If you do not agree with the Service-specific terms, please do not use the Service in question.

Idea Submission Policy. I recognize that Britannica is always innovating and working on ideas, products, processes, and technologies for use in new and existing products. For this reason, Britannica does not accept or consider unsolicited ideas, including without limitation ideas for new or improved products, creative works, marketing plans, or product names (collectively, "Ideas"). Please do not submit any unsolicited Ideas in any form to Britannica. If, despite our request that you not send us Ideas, you still submit an Idea, then regardless of what you say in your submission, the following terms shall apply: You agree that:

- Your Idea and its contents will automatically become the property of Britannica without any compensation of any kind owed to me by Britannica or any of its affiliates. Britannica may redistribute your Idea and its contents for any purpose and in any way.
- Neither Britannica nor any of its affiliates is obligated to keep confidential your Idea or any of the information that you submit to us. You agree and acknowledge that all Ideas and information submitted by you will be treated as non-confidential information.
- Britannica does not have any obligation to evaluate your Idea.

Disclaimer of Warranties. THE SERVICES AND ALL INFORMATION, PRODUCTS, AND OTHER CONTENT INCLUDED IN OR ACCESSIBLE FROM THE SERVICES ARE PROVIDED "AS IS" AND WITHOUT WARRANTIES OF ANY KIND (EXPRESS, IMPLIED, AND STATUTORY, INCLUDING BUT NOT LIMITED TO THE IMPLIED WARRANTIES OF MERCHANTABILITY AND FITNESS FOR A PARTICULAR PURPOSE), ALL OF WHICH BRITANNICA EXPRESSLY DISCLAIMS TO THE FULLEST EXTENT PERMITTED BY LAW.

Limitation of Liability. IN NO EVENT SHALL BRITANNICA, ITS DIRECTORS, OFFICERS, SHAREHOLDERS, PARENTS, SUBSIDIARIES, AFFILIATES, AGENTS AND LICENSORS, OR CONTENT PROVIDERS BE LIABLE: (i) FOR ANY INDIRECT, SPECIAL, INCIDENTAL, PUNITIVE, OR CONSEQUENTIAL DAMAGES ARISING OUT OF OR RELATED TO THE USE, INABILITY TO USE, PERFORMANCE OR NONPERFORMANCE OF THE SERVICES, EVEN IF BRITANNICA WAS PREVIOUSLY ADVISED OF THE POSSIBILITY OF SUCH DAMAGES AND REGARDLESS OF WHETHER SUCH DAMAGES ARISE IN CONTRACT, TORT, UNDER STATUTE, IN EQUITY, AT LAW, OR OTHERWISE; AND (ii) FOR ANY DAMAGES, LOSSES AND/OR CAUSES OF ACTION EXCEEDING ONE THOUSAND U.S. DOLLARS (US \$1,000) IN THE AGGREGATE.

SOME JURISDICTIONS DO NOT ALLOW LIMITATIONS ON IMPLIED WARRANTIES OR THE EXCLUSION OR LIMITATION OF CERTAIN DAMAGES, SO SOME OF THE ABOVE LIMITATIONS AND EXCLUSIONS MAY NOT APPLY TO YOU.

Indemnification. To the fullest extent permitted by law, you agree to indemnify and hold Britannica, its directors, officers, shareholders, parents, subsidiaries, affiliates, agents, and licensors harmless from and against all losses, expenses, damages, and costs, including reasonable attorneys' fees, arising out of (i) the information or material you submit, including, but not limited to, liability for violations of copyrights, trademark rights, trade secret rights, or any other intellectual property rights, or the privacy or publicity rights of others, or liability for information or material you provide that is obscene, defamatory, threatening, harassing, abusive, hateful or embarrassing to any other person or entity, or is fraudulent or deceptive, (ii) your use or unauthorized copying of the Services or any of their content, or (iii) your violation of these Terms of Use or any applicable laws or regulations.

Governing Law. You agree that all matters relating to your access to or use of the Services and these Terms of Use, including all disputes, will be governed by the laws of the United States and the State of Delaware, without giving effect to any principles of conflicts of laws, including the United Nations Convention on Contracts for the International Sale of Goods.

Class Action Waiver. YOU AND BRITANNICA AGREE THAT EACH PARTY MAY BRING DISPUTES AGAINST THE OTHER PARTY ONLY IN AN INDIVIDUAL CAPACITY, AND NOT AS A PLAINTIFF OR CLASS MEMBER IN ANY PURPORTED CLASS OR REPRESENTATIVE PROCEEDING, INCLUDING, WITHOUT LIMITATION, A FEDERAL OR STATE CLASS ACTION LAWSUIT. NEITHER YOU NOR BRITANNICA WILL SEEK TO HAVE ANY DISPUTE HEARD AS A CLASS ACTION, PRIVATE ATTORNEY GENERAL ACTION, OR IN ANY OTHER PROCEEDING IN WHICH EITHER PARTY ACTS OR PROPOSES TO ACT IN A REPRESENTATIVE CAPACITY. Nothing in this paragraph limits your right or Britannica's right to bring a lawsuit against each other as an individual plaintiff.

Claims or Disputes Must be Filed within One Year. To the extent permitted by law, any claim or dispute arising out of or related to use of the Services or these Terms of Use must be filed within one year after such claim or dispute arose. The one-year period begins when the notice of such claim or dispute first could be filed. If such a claim or dispute is not filed within one year, it shall be permanently barred. Any claim by you that may arise in connection with these Terms of Use will be compensable by monetary damages and you will in no event be entitled to injunctive or other equitable relief.

Opting Out of Pop Under Ads. Some of our pop-under ads are not detected by Safari and other browsers. To opt out of pop-under ads visit <http://optmd.com>.

Not Advice. Information contained in the Services is not intended to be medical, legal, tax, financial or other advice and should not be considered medical, legal, tax, financial or other advice, nor is it intended to replace consultation with a qualified physician, attorney or other professional.

Severability. If any provision of these Terms of Use shall be unlawful, void or for any reason unenforceable, then that provision shall be deemed severable from these Terms of Use and shall not affect the validity and enforceability of any remaining provisions.

Survival. The provisions of these Terms of Use which by their nature should survive the termination of these Terms of Use shall survive such termination.

Waiver. No waiver of any provision of these Terms of Use shall be deemed a further or continuing waiver of such provision or any other provision, and your or our failure to assert any right or provision under these Terms of Use shall not constitute a waiver of such right or provision.

Entire Agreement. These Terms of Use constitute the entire agreement between Britannica and you, superseding any prior or contemporaneous communications and proposals (whether oral, written or electronic).

SECTION 2

Additional Terms of Use for Consumer Subscriptions and Parents and Guardians of Children Under 16 Years Old

Security of Subscription. Some of the Services are available only by subscription (the "Subscription Services"). Your right to use the Subscription Services for which you have subscribed is personal to you or members of your immediate family residing with you. If you are authorized only by an Institutional Subscriber (such as your employer, a school or library) to access and use any of the Subscription Services, your right to use the Subscription Services is not transferable to your family members; the Institutional Subscription-specific Terms of Use for individuals who benefit from an Institutional Subscription are at [Section 3](#) below. You are responsible for protecting the confidentiality of your credentials for access to the Subscription Services (e.g., your username and password) and for complying with any guidelines prescribed by Britannica from time to time to prevent unauthorized access to the Subscription Services. You agree to immediately notify Britannica of any unauthorized use of your password or any other breach of security. Britannica reserves the right to perform one-way encryption of passwords for account maintenance purposes.

Notice to Parents and Guardians. By granting your child permission to use the Subscription Services, you agree to these Terms of Use on behalf of your child. You are responsible for monitoring and supervising your child's use of the Subscription Service in question. If your child is using our Subscription Service and is either under 16 or does not have your permission, please contact us immediately so that we can disable his or her access. If you have questions about whether the Subscription Service is appropriate for your child, please contact us.

Subscriber Agreement

Definitions. As used in these additional terms, "you" or "yours" refers to each person who establishes a subscriber account ("Account") or who is authorized to access and use any of the Subscription Services.

Account. You are responsible for all use of your Account under any user ID (username or email address) or password by any person and for ensuring that all use of your Account complies fully with the provisions of this Usage Agreement.

Subscription Fees and Changes. Subscription charges begin on the date your Services subscription is activated or, if applicable, on the date your free trial period ends, and will be billed to your credit or charge card each month (for monthly subscriptions) or year (for annual subscriptions) thereafter. You acknowledge and agree that you will not receive a bill in the mail for your subscription. Britannica reserves the right to increase subscription rates at any time. Changes to standard subscription rates will be posted at http://corporate.britannica.com/standard_rates.html or in a Britannica communication to you. Increases in subscription rates will apply to existing accounts at the time of their renewal and will not exceed the standard subscription rate that has been in effect and posted for at least 30 days. Reductions in the standard subscription rate will not necessarily be reflected in your renewal subscription rate. Customers subscribing at specially discounted promotional rates may be subject to varying rate increases, none of which shall exceed the standard posted subscription rate.

Termination of Subscription and Free Trial. Either party shall have the right to terminate your subscription at any time by providing notice of termination to the other. In the event of termination of your subscription by either party, you shall have no claims against Britannica or its affiliates. Termination of your subscriptions or free trial automatically terminates your license to use the Subscription Services and any content or other material contained therein. If you acquired an annual subscription to one of the Subscription Services and you terminate your subscription within 30 days of the date of activation of your Account, you are eligible to receive a refund of the subscription fee paid to Britannica; you must contact Britannica Customer Support to receive this refund. If you are a resident of the Netherlands, you can terminate at any time during your annual subscription, on 30 days notice, and receive a pro-rated refund. If you acquired a monthly subscription to the Subscription Services or if your subscription is acquired with a Promotion Certificate and you terminate your subscription, you will not receive any refund of the subscription fee paid to Britannica. If your subscription to the Subscription Services was acquired with a Gift Certificate and you terminate your subscription within 30 days of the date your Gift Certificate was acquired from Britannica, you are eligible to receive either: (a) a refund of the subscription fee paid to Britannica (available only to the party acquiring your Gift Certificate from Britannica); (b) a credit towards the price of acquiring other Britannica products or services; or (c) a credit towards the future subscription fee for an existing Subscription Services subscription. You must contact Britannica Customer Support to receive these remedies. If Britannica terminates your subscription, other than as a result of your breach of this Agreement, Britannica will refund to you a pro rata portion of the subscription fee paid to Britannica, if any, for the unexpired portion of your subscription.

Subscription Changes. If you acquired an annual subscription to the Subscription Services and you wish to change to another Subscription Service offering you may do so without penalty within 30 days of the activation of your Account. You must contact Customer Service to request this or other changes from one Subscription Service to another. If you acquired a monthly subscription to the Subscription Services and you wish to change to another Subscription Service offering, contact Customer Service, the change will be made effective when your current monthly term ends.

Renewals and Cancellations. Your subscription will renew automatically unless we terminate it or you notify us by telephone or email (receipt of which must be confirmed by email reply from us) of your decision to cancel your subscription. You must cancel your subscription before it renews in order to avoid billing of subscription fees for the renewal term to your credit card. Instructions on how to cancel your subscription are available at <https://myaccount.britannica.com>. In the event that you cancel your subscription, unless otherwise required by law, subscription fees will not be refunded, applied to another subscription, or transferred to anyone else and are not convertible to cash or other form of credit. Payments made as part of a monthly subscription cannot be used as credit toward annual subscription charges and are non-transferable.

Credit Cards or Charge Cards. You agree that you will provide a major credit or charge card (e.g., MasterCard, Visa, American Express, or Discover) that Britannica may charge for all subscription fees or other amounts payable to Britannica. With respect to such charges, you give the following authorization:

I authorize automatic credit or charge card billing by Britannica. I agree that the charges described above will be billed by Britannica to the credit or charge card that I have provided to Britannica in my Account information, or otherwise when I applied for the Subscription Services. I understand that all fees and charges are nonrefundable. I agree that Britannica will not be responsible for any expenses that I may incur resulting from overdrawing my bank account or exceeding my credit limit as a result of an automatic charge made under this Agreement.

Account Information. You agree to provide current, complete, and accurate information for your Account in order to receive access to the Subscription Services. You agree to promptly update all Account information to keep your account current, complete, and accurate (such as a change in billing address, credit or charge card number, or credit or charge card expiration date) and you must promptly notify Britannica if your credit or charge card is cancelled (for example, for loss or theft) or if you become aware of a potential breach of security, such as the unauthorized disclosure or use of your log-in and password. Changes to such information can be made by going to the Account Maintenance

area at <https://myaccount.britannica.com>. If you fail to provide Britannica any of the foregoing information, you agree that Britannica may assume that your credit or charge card is either still valid or that it has been renewed and may continue charging you for the Subscription Services to which you have subscribed, unless you have cancelled your subscription.

SECTION 3 Institutional Subscription Terms

Definitions. Institutional Subscribers may be a business (“**Business**”), government agency (“**Agency**”), school and related facilities (“**School**”), college or university (“**University**”) or public library (“**Library**”). “**Authorized Users**” are the following: (i) employees, agents or representatives in the case of Businesses and Agencies; (ii) students of Subscriber, its faculty members, administrators, and employed staff in the case of Schools; (iii) full or part-time students of Subscriber, its faculty members, administrators and employed staff in the case of Universities; and (iv) patrons, employees, agents or representatives in the case of Libraries.

Remote Access. Only Authorized Users are permitted to access the Services remotely. Authorized Users are (a) in the case of Schools: its students, its faculty members, administrators, and employed staff; (b) in the case of Universities: its full or part-time students, its faculty members, administrators and employed staff; (c) in the case of Businesses and Government Agencies: employees, agents and representatives; and (d) in the case of a National, State or Public Library, its Library patrons, Library customers, and Library users, employees, agents and representatives. Only these individual persons are permitted to access the Services remotely. Schools, Universities, Businesses and Government Agencies who are members of a National, State or Public Library are not Authorized Users under a Library’s license agreement with Britannica.

SECTION 4 Service-Specific Terms

Nglish™ and Britannica English Arabic Translation

The following additional terms apply to your use of the Nglish™ and Britannica English Arabic translation services, which are powered by our subsidiary, [Merriam-Webster, Incorporated](#), including any related mobile application services (the “Translation Products”). Your use of the Translation Products, is your acceptance of these Terms of Use, including, specifically, these additional terms.

Ownership. All rights to the content contained in the Translation Products, including any words, definitions, idioms, expressions, translations (in English, Spanish, Arabic or any other language), diacritics and vowel signs, links between words’ voice files, grammatical inflections, topical word lists, graphic and game content, and any other content that appears in the Translation Products, are the sole property of Britannica, its affiliated companies or licensors.

Prohibited Uses. The Translation Products are intended solely for translations of single words and expressions. You may not run word lists consecutively through the Translation Products, whether using software or manually, nor may you create any files, lists or databases using the Translation Products. You may not use systems to extract any data from the Translation Products, including data pertaining to any entries, translations, voice files, grammatical declensions, or registered user subscription details. Britannica reserves the right to block a user whose pattern of use of the Translation Products violates these Terms of Use.

User Registration. With respect to Nglish™ specifically, in order to save words in your personal file, you must register for “Nglish Dictionaries.” Registration to “Nglish Dictionaries” may be done through an online account you may have with a third party social networking site, using your email address, or any other valid registration process offered from time to time by Britannica. By registering with a Translation Product, you grant Britannica your explicit consent to notify you of version upgrades and changes to and promotions for the Translation Products provided by or through Britannica. If you wish to cease these notifications, please email your request to Britannica using the contact information provided within the related Translation Product.

SECTION 5 Legal Notices

Copyrights

All contents of the Services are © Encyclopædia Britannica, Inc. or its licensors. All rights reserved. Encyclopædia Britannica is copyrighted 1994-2021 by Encyclopædia Britannica, Inc.

The 1997, 1998, 1999, 2000, 2001, 2002, 2003, 2004, 2005, 2006, 2007, 2008, 2009, 2010, 2011, 2012, 2013, 2014, 2015, 2016, 2017 and 2018 Britannica Books of the Year are copyrighted 1998, 1999, 2000, 2001, 2002, 2003, 2004, 2005, 2006, 2007, 2008, 2009, 2010, 2011, 2012, 2013, 2014, 2015, 2016, 2017, 2018 and 2019 respectively, by Encyclopædia Britannica, Inc.

Britannica claims no compilation copyright in images or materials that are subject to the GNU Free Documentation License or similar licenses.

Merriam-Webster's Collegiate® Dictionary (Eleventh Edition), Merriam-Webster's Online Dictionary, and Merriam's Webster's Student Dictionary (Third Edition), are all copyrighted by Merriam-Webster, Incorporated.

Photographs and illustrations are copyrighted by their respective owners, as noted in the credits.

Trademarks

"Encyclopædia Britannica" and other marks that appear throughout the Services belong to Encyclopædia Britannica, Inc., its affiliates, or third-party trademark owners.

Google Drive™ is a trademark of Google Inc. Use of this trademark is subject to [Google Permissions](#).

Except as permitted by applicable laws, you are prohibited from using any of the marks appearing on the Services without express written consent from Britannica or the respective trademark owners.

Copyright Infringement Claims

If you believe that any copyright infringement exists on any of the Services, please use the following process to notify Britannica. We will act expeditiously to remove infringing material once informed. All claims of copyright infringement should be in writing and should be directed to our Designated Agent below:

Carmen E. Pagán, Copyright Manager
Encyclopædia Britannica, Inc.
325 North LaSalle Street, Suite 200
Chicago, Illinois 60654
Fax: 312/294-2118
Phone: 312/347-7000
E-mail: copyrightnotice@eb.com

Your notice must contain the following information:

1. Your physical or electronic signature (as either the owner of an exclusive right that is allegedly infringed or as a person authorized to act on behalf of such owner).
2. Identification of the copyrighted work claimed to have been infringed or, if multiple copyrighted works at a single online site are covered by a single claim, a representative list of such works at that online site.
3. Identification of the material that is claimed to be infringing or to be the subject of infringing activity and that is to be removed or access to which is to be disabled and information reasonably sufficient to permit Britannica to locate the material.
4. Information reasonably sufficient to permit Britannica to contact you, such as an address, telephone number and, if available, an electronic mail address.
5. A statement that you believe in good faith that use of the material in the manner complained of is not authorized by the copyright owner, its agent or the law.
6. A statement that the information in the notice is accurate and that, under penalty of perjury, you are the owner of an exclusive right that is allegedly infringed or are authorized to act on behalf of such owner.

Britannica has a policy of terminating in appropriate circumstances the subscriptions of users who are infringers of copyrights held by others. If your material is removed or access to it is disabled and you believe in good faith that a claim has been wrongly made against you, you may submit a counter-notification to Britannica. Your counter-notification must be in writing and sent to:

Carmen E. Pagán, Copyright Manager
Encyclopædia Britannica, Inc.
325 North LaSalle Street, Suite 200
Chicago, Illinois 60654
Fax: 312/294-2118
Phone: 312/347-7000
E-mail: copyrightnotice@eb.com

Your counter-notification must contain the following information: **158**

1. Your physical or electronic signature.

2. Identification of the material that has been removed or to which access has been disabled and the location at which the material appeared before it was removed or access to it was disabled.
3. A statement under penalty of perjury that you have a good faith belief that the material was removed or disabled as a result of mistake or misidentification of the material to be removed or disabled.
4. Your name, address, and telephone number, and a statement that you consent to the jurisdiction of Federal District Court for the judicial district in which you are located, or if you are outside of the United States, for any judicial district in which Britannica may be found, and that you will accept service of process from the person who notified Britannica of the alleged infringement or an agent of such person.

©2021 Encyclopædia Britannica, Inc. All Rights Reserved.



Executive Summary Board of Education Meeting

DATE: June 1, 2023

TOPIC: Interactive Display Refresh

PREPARED BY: Jordan Stephen

Recommended for:

- Action
- Discussion
- Information

Purpose/Background:

As the District refreshes equipment, we must remember that classroom technology also has a certain lifespan. As we upgrade technology, some of these features either get more difficult to use or simply get phased out because of physical connections and changes within hardware.

Two years ago, the coaches and members of the technology team were able to visit another district and see the possibilities of new Digital Interactive Displays. The district deployed demo units into Todd Hall for teachers to model and experience all of the advancements and the ease of use of the new technology. During the rollout, led by the Todd Hall tech coach, the responses were great.

At both Todd Hall and Rutledge Hall, there are many ceiling or wall-mounted projectors and/or Smartboard devices built for interaction with students. In our inventory, the district owns many different models of Epson Interactive Projectors, Boxlight Brand projectors, and various models of SmartBoards - all in various sorts of working order. As internal discussions continued, the district initially looked at phasing in interactive displays to replace the broken Smartboards, Epson, and Boxlight Projectors.

Last year in Phase 1, we replaced over 60% of the technology within the classrooms in Todd Hall with the BenQ Interactive Panels. The feedback has been very positive from all who are using the interactive displays.

This year, during Phase 2, the District will replace displays in 10 additional rooms at Todd Hall. Rutledge Hall is in the physical same state when it comes to the age and current inventory of the ceiling mounted or wall-mounted projectors within the classrooms. During Phase 2 we are also planning on replacing a number of aging devices within 14 classrooms at Rutledge Hall. The final board in this purchase will be used as not only a spare for the district in case of breakage, but also a unit that can be used for testing login processes, management of the units and the testing of applications that can be installed locally on the interactive boards.

TODD HALL REPLACEMENT SCHEDULE

Room #	Room #		Room #	Projector Type
211	Smart UX60		202	Smart UF70
315	Smart UX60		204	Smart UF55
102C	Smart UX60		201	Smart
102E	Smart UX70		302	Epson
213	Smart UX60		???	New TH Classroom

RUTLEDGE HALL REPLACEMENT SCHEDULE

Room #	Room #		Room #	Projector Type
35	Boxlight P8/Whiteboard		5	Boxlight P8/Whiteboard
32	Boxlight P8/Whiteboard		4	Boxlight P8/Whiteboard
31	Boxlight P8/Whiteboard		29	Epson Brightlink W485i/Whiteboard
30	Boxlight P8/Whiteboard		2	Epson Brightlink W485i/Whiteboard
27	Boxlight P8/Whiteboard		43	Epson Brightlink W725i/Whiteboard
26	Boxlight P8/Whiteboard		41	Smart UX60/Smartboard Portable
25	Boxlight P8/Whiteboard		37	Smart UX70/Smartboard 800

Product Description/Details

There are many products that are filling up this market place but the one that meets the needs of our District is the BenQ brand board. (See attached brochure for more details)

- 65" Interactive Flat Panel
- 4K UHD 3840 x 2160 Pixels Resolution
- 450 nits Brightness
- IR Touch Technology
- 30,000:1 Dynamic Contrast Ratio
- USB B Touch Port x3
- USB C Port
- HDMI Port x3
- Wireless Technology
- Remote Control
- 0.15in (4mm), Tempered Glass
- Anti-Glare & Germ-Resistant Screen
- Built-in Microphone Array



- ☐ IPS Backlight / Light source
- ☐ 178° Viewing Angle (Horizontal / Vertical)
- ☐ 8ms Response Time
- ☐ Speakers 15W x2
- ☐ Landscape Display Orientation

When you combine the power of a built-in internet web browser, whiteboard, and shared live screens, with the ability to install and run selected applications, learning and classroom interactivity truly comes alive.

Fiscal Impact:

\$61,000 - The District would pay **\$55,375.25** for a total of 25 BenQ Interactive displays at Todd Hall and Rutledge Hall. The District would pay **\$4,557.60.*** for a total of 24 adjustable height stands at Todd Hall. **This estimate could change slightly due to the consistent fluctuation in price and availability of the mobile monitor stands required. Prices shown based upon current published price.* During the 2022-2023 school year the District spent \$48,900 on the 1st phase of the display refresh at Todd Hall.

Recommendation:

The Finance Committee concurs with the Administration to recommend to the Board of Education to approve the purchase of 25 classroom displays in the amount, not to exceed \$61,000 for the 2023-2024 school year.



Because it matters

Dealer's Stamp

Headquarters BenQ Corporation 16 Jihu Road, Neihu, Taipei 114, Taiwan Tel : +886-2-2727-8899 Fax : +886-2-2656-2438	Asia Pacific BenQ Asia Pacific Corp. 12 Jihu Road, Neihu, Taipei 114, Taiwan Tel : +886-2-2727-8899 Fax : +886-2-2656-2438	China BenQ (IT) Co., Ltd. 181 Zhuyuan Road, Suzhou New District, Suzhou, China Tel : +86-512-6807-8800 Fax : +86-512-6809-7010	North America BenQ America Corp. 3200 Park Center Drive, Suite 150 Costa Mesa, CA 92626 U.S.A Tel : +1-714-559-4900 Fax : +1-714-557-0200	Europe BenQ Europe B.V. Meerenakkerweg 1-17, 5652 AR Eindhoven, The Netherlands Tel : +31(0) 88-888-9200 Fax : +31(0) 88-888-9299	Latin and Central America BenQ Latin America Corp. 8200 N.W. 33 Street, Suite 301 Miami, FL 33122 U.S.A. Tel : +1-305-421 1200 Fax : +1-305-421 1201
---	--	--	--	--	---

© 2020 BenQ Corp. Specification may vary by region, please visit your local stores for details. Actual product's features and specifications are subject to change without notice. This material may include corporate names and trademarks of third parties which are the properties of the third parties respectively. Doc: PDP_RM6503/RM7503/RM8603_IFP_EN_202112

Foster effective learning while protecting teachers and students



Interactive Displays for Education

RM6503 / RM7502 / RM8603

- 
Germ-Resistant Screen & Pen
- 
Flicker-Free
- 
Low Blue Light
- 
Anti-Glare
- 
InstaShare
- 
EZWrite



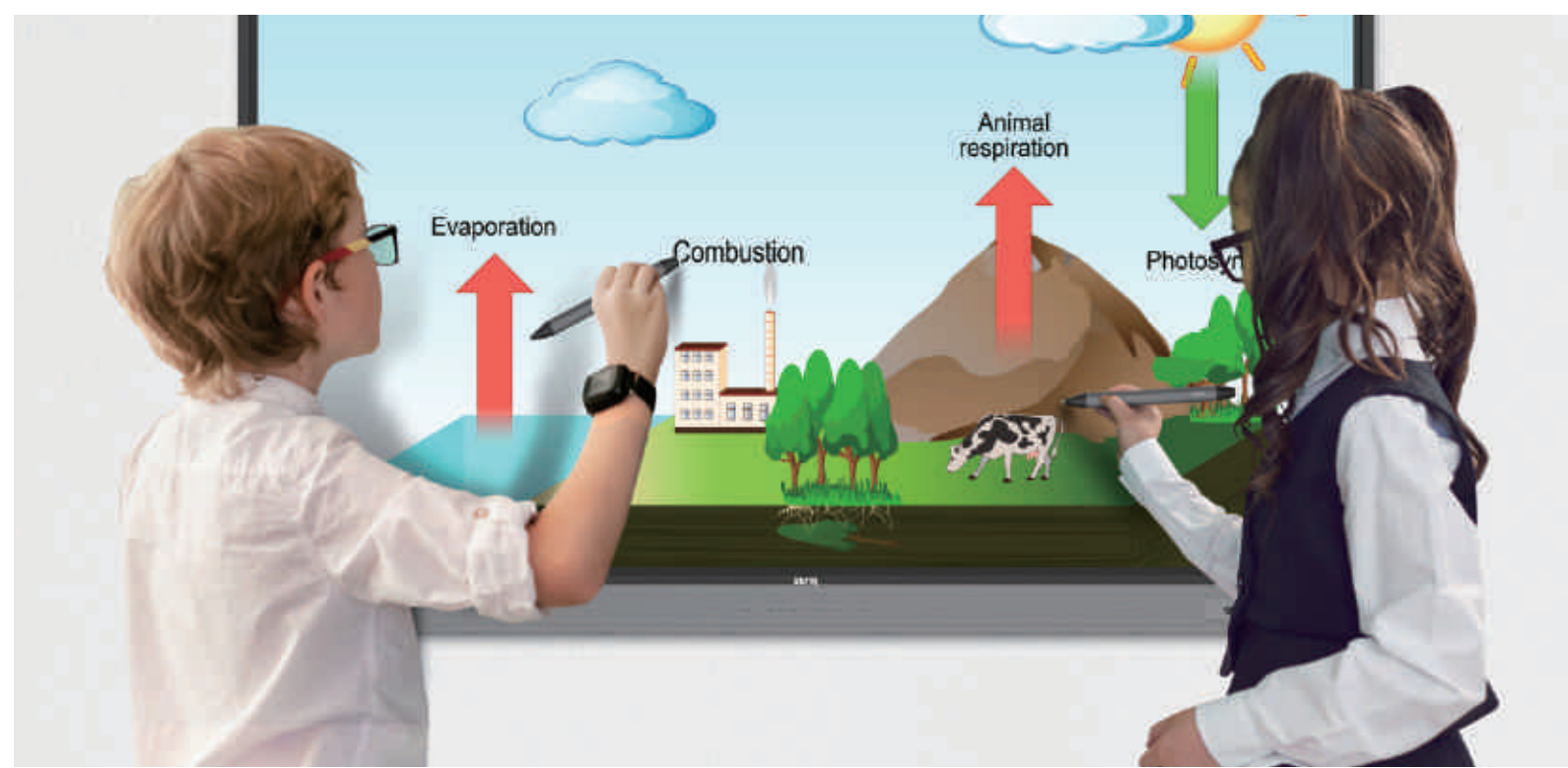

From in-class to hybrid to distance learning

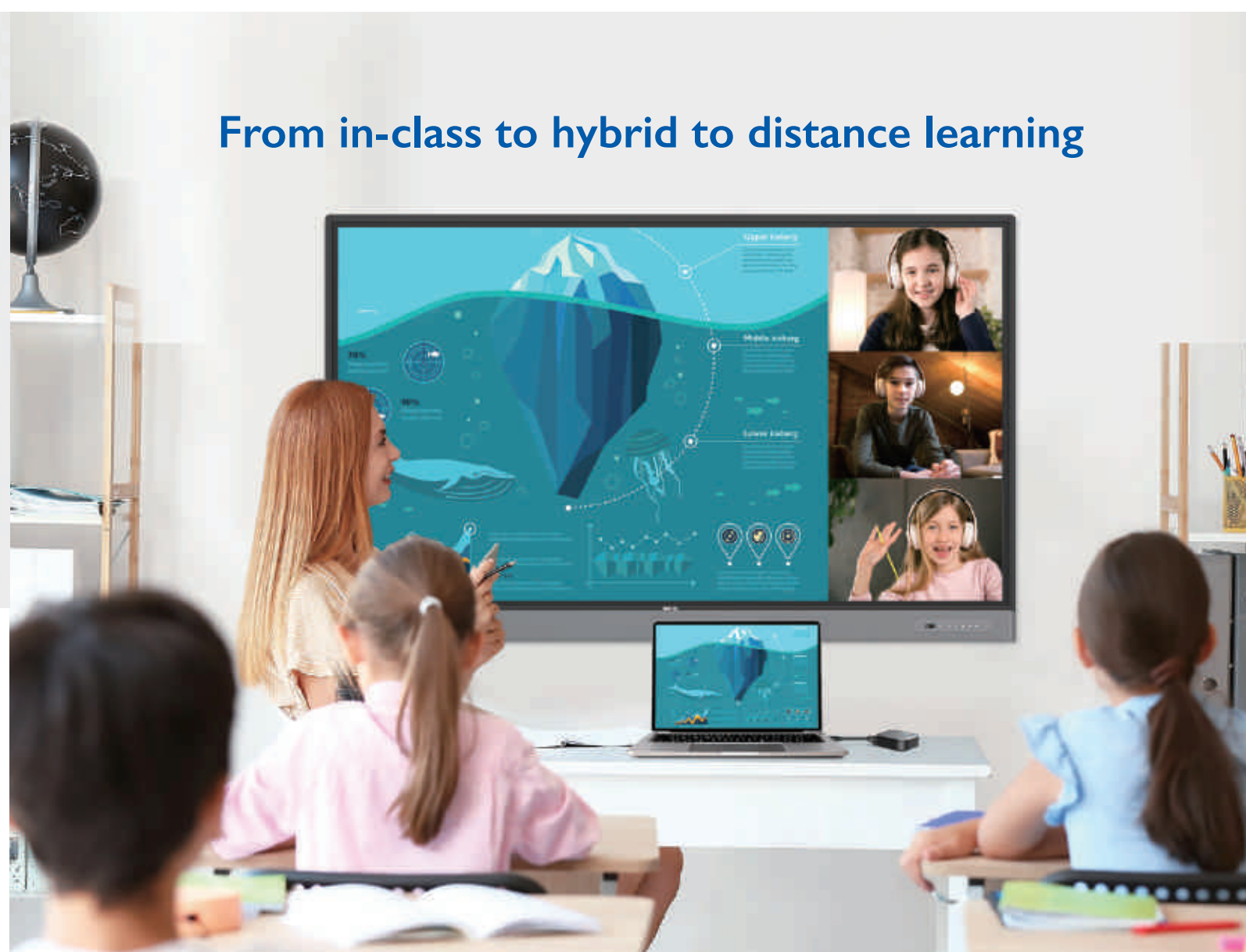

A display that protects the entire class



Defend against the spread of germs

Reduce disease transmission in the classroom with germ-resistant screens and pens. All BenQ interactive displays have touchscreens coated with a nano-ionic silver formula that kills 99.9% of common germs after contact.

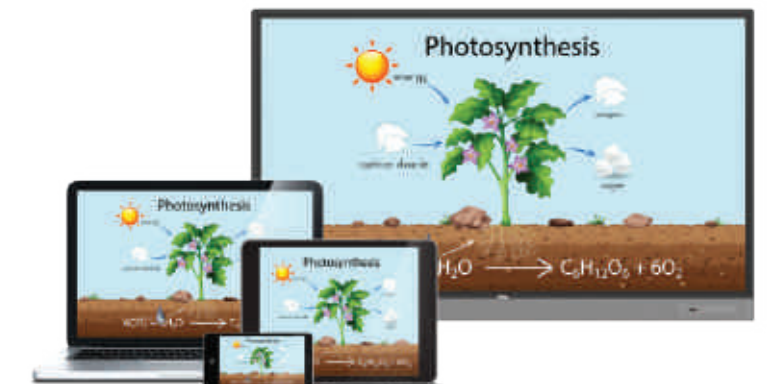

Enhanced eye comfort

BenQ displays come with low blue light and flicker-free technology for reduced eye strain and a comfortable viewing experience. Anti-glare screens additionally ensure that display content is seen clearly, even on hybrid and remote calls.



Flicker-Free



Low Blue Light



Anti-Glare



BenQ screen

Other screen

Explore ideas without limits

Foster collaborative learning with an intuitive whiteboard. EZWrite 6 lets you work on the canvas from the interactive display or your device.

Untethered screen sharing

Empower students to wirelessly present their ideas in class without the hassle of cables. InstaShare 2 lets students simultaneously cast their device screens onto the interactive display.

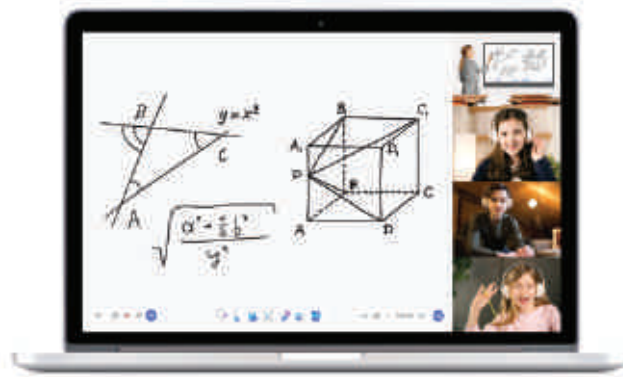

Bridging classrooms with video conferencing

Have students learn from home or invite a guest speaker to join remotely. The RM03 is compatible with all leading video conferencing software such as Zoom, Google Meet, and Microsoft Teams.

*Available with slot-in PC



Side-by-side learning

Make lessons more efficient by running two apps side by side. Explain in detail with a whiteboard on one side and supporting content on the other.

*Available Q1 2022

Made for teachers



Hear and be heard

The built-in 2 x 16W speakers and 6-microphone array ensure that the entire class can hear and be heard during hybrid and remote lessons.

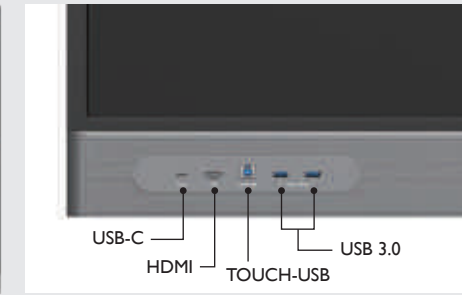

Convenient connectivity

The front ports cover all your connectivity needs. Charge your notebook, display your screen, and enable touch with a single Type-C cable.



Voice assistant

Teach lessons on the RM03 from anywhere in the room with the remote control and voice assistant for increased accessibility.

*Available Q1 2022

Made for IT and admin staff



A more personalized experience

Load your personal settings and files on any display. Securely access lesson materials on Dropbox, Google Drive, and OneDrive.



Effective communication across campus

Keep everyone informed and up to date on events, safety protocols, and emergencies. Deliver clear and effective messages to multiple BenQ displays with X-Sign Broadcast.



Device analytics at a glance

Easily monitor and analyze the status of all your BenQ devices on a single dashboard. Manage displays, apps, and OTA updates remotely for maximum convenience.



IP5X dust protection

The panel meets IP5X standards to ensure consistent operation, even in dust-prone environments.

**Complies with IEC standard 60529

Dimensions

RM6503

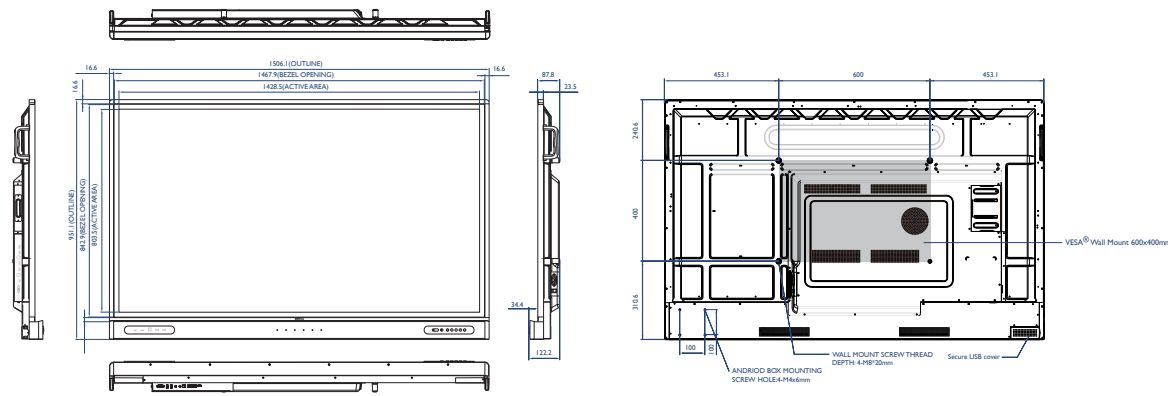

RM7503

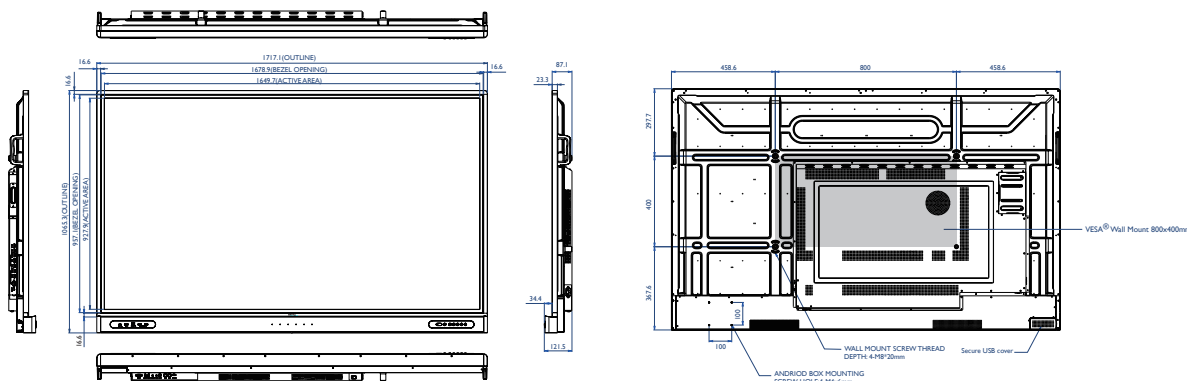

RM8603

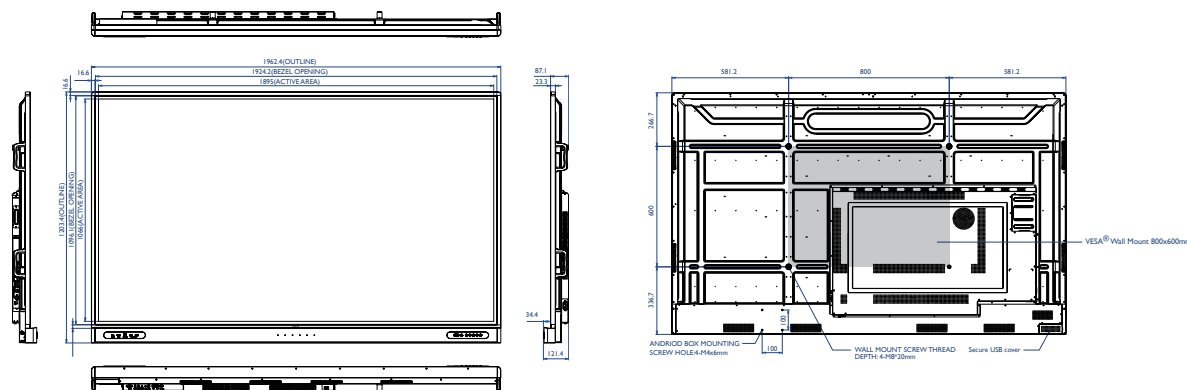

Input/output ports

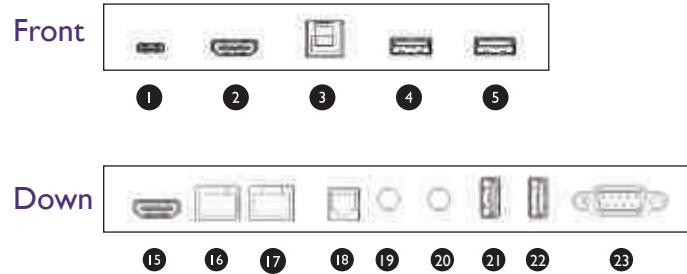

Side

No.	Name	No.	Name
1	USB-C	13	VGA
2	HDMI	14	Audio
3	TOUCH-USB	15	HDMI
4	USB 3.0	16	LAN
5	USB 3.0	17	LAN
6	USB 3.0	18	SPDIF
7	USB 3.0	19	Microphones
8	TOUCH-USB	20	Audio
9	DP	21	USB 2.0
10	HDMI	22	USB 2.0
11	TOUCH-USB	23	RS232
12	HDMI		

Specifications

Model	RM6503	RM7503	RM8603
Panel			
Screen size	65"	75"	86"
Resolution	UHD 3840 × 2160 pixels	UHD 3840 × 2160 pixels	UHD 3840 × 2160 pixels
Aspect ratio	16:9	16:9	16:9
Brightness (typical)	400 nits	450 nits	450 nits
Contrast ratio (typical)	1200:1	1200:1	1200:1
Dynamic contrast ratio	30,000:1	30,000:1	30,000:1
Color depth	10-bit	10-bit	10-bit
Response time	8 ms	8 ms	8 ms
Color gamut	72% NTSC	72% NTSC	72% NTSC
Operation hours	18 hours / 7 days	18 hours / 7 days	18 hours / 7 days
Orientation	Landscape	Landscape	Landscape
Light life (typical)	50,000 hrsit	50,000 hrs	50,000 hrs
Glass			
Hardness		9H tempered	
Germ-resistant technology		Nano-ionic silver	
Anti-glare coating		Yes	
Touch screen			
Touch technology		Infrared touch	
Touch points		40 (Windows: 40 ; Android : 32 ; Available in 2022)	
Touch response time		< 10 ms	
Platform System			
CPU		A73 × 4	
Memory Storage		8GB 32 GB	
OS		Android 9.0	
Connectivity			
HDMI (in out)		3 × HDMI 2.0 1 × HDMI 2.0	
DisplayPort (in out)		1 × 1.2 No	
DVI (in out)		N/A	
VGA (in out)		1 0	
3.5 mm audio in (VGA)		1	
3.5 mm audio (in out)		mic-in line-out	
SPDIF (in out)		0 1 (optical)	
USB-A		2 × 2.0 + 5 × 3.2 Gen I	
USB-B (for touch)		2 × 2.0 + 1 × 3.2 Gen I	
USB-C		1 × 3.1	
Slot-in PC (OPS)		1	
Built-in peripherals			
Microphone		6	
Speaker		2 × 16 W	
Power			
Power	AC 100-240V 50/60Hz	AC 100-240V 50/60Hz	AC 100-240V 50/60Hz
Maximum Power Consumption	335 W	396 W	448 W
Typical Power Consumption	118 W	146 W	180 W
Physical			
Shipping dimensions (W × H × D)	1660 × 1160 × 220 mm (65.4 × 45.7 × 8.7 inch)	1900 × 1160 × 225 mm (74.8 × 45.7 × 8.9 inch)	2140 × 1340 × 250 mm (84.3 × 52.8 × 9.8 inch)
Weight (product shipping)	41.2 kg 52.7 kg (90.8 lbs 116.2 lbs)	53.0 kg 72.0 kg (116.8 lbs 158.7 lbs)	68.6 kg 89.5 kg (151.2 lbs 197.3 lbs)
Mount (screws)	VESA 600 × 400 mm (4 × M8 × 20L)	VESA 800 × 400 mm (4 × M8 × 20L)	VESA 800 × 600 mm (4 × M8 × 20L)
Pen Tray			
Accessories			
Cables	1 × VGA (3m), 1 × HDMI (3m), 1 × USB-C (1.5m) × USB-B touch Cable (3m)		
Wall mount			
Stylus	2 2 2		
Remote Controller			
PWR cord (by region)	BQE × 2 (EU,UK) ; BQP × 7(EU, US, AU, TW, JP, UK, IN) ; BQA × 1 (US) ; BQin × 1 (IN) ; BQTW × 1; BQC × 1 (CN) ;		
OSD	(27L) EN/EF/GM/DT/PL/RS/CZ/DN/SW/IT/RM/FN/NG/GK/HG/SP/EP/TC/CNAB/JJP/TH/PS/VT/KR/TR/ID		



Midwest Computer Products, Inc.
AV PRODUCTS & SERVICES

MIDWEST COMPUTER PRODUCTS, INC. Quote
33W 512 ROOSEVELT ROAD **720251**
WEST CHICAGO, IL 60185

P. 630-232-0010
F. 630-232-0559

02-16-
23

Quoted To

LINCOLNWOOD SCHOOL DISTRICT 74
6950 N EAST PRAIRIE RD
ACCOUNTS PAYABLE
LINCOLNWOOD, IL 60712
Acct# 4415

Ship To

LINCOLNWOOD SCHOOL DISTRICT 74
6950 N EAST PRAIRIE RD
LINCOLNWOOD, IL 60712

65 Inch BenQ Displays

Sales Rep Tom Warda; twarda@midwestcomputer.com

Part #	Description	Qty	Price	Ext. Price
BENRM6503	BENQ, 65" INTERACTIVE DISPLAY (3 YEAR WARRANTY) PA231.039	25.00	\$2,215.00	\$55,375.00
BEN5A.F7W28.DP1	WIRELESS	25.00	\$0.01	\$0.25
Comments: Free Freight (Dock to Dock)		Item Total		\$55,375.25
		Ship Chg		
		Sales Tax		\$0.00
		Quote Total		\$55,375.25

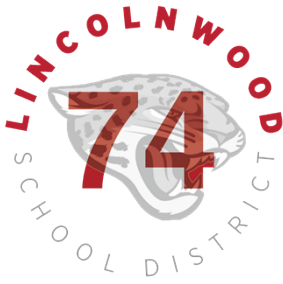

Executive Summary Board of Education Meeting

DATE: June 1, 2023

TOPIC: 2023-2024 Learning A-Z Product Renewal

PREPARED BY: Jordan Stephen

Recommended for:

- Action
- Discussion
- Information

Purpose/Background:

The Learning A-Z Company creates many products that are used within the District. Titles like Vocabulary A-Z, Raz-Kids, Reading A-Z, and Raz-Plus provide the teachers and students with resources and content to help reinforce independent reading, word recognition and vocabulary concepts. These products are used by hundreds of students throughout the District and provide them with lessons that seamlessly connect instruction to a current topic of study. Teachers can assign lessons to students for online independent practice as well as differentiated instruction to help raise student achievement.

The team continues to evaluate the usage of this product and discusses with teachers and teams to determine the minimum number of licenses the District needs to accomplish all educational goals. The renewal presented is based on 24 licenses for Vocabulary A-Z, 27 licenses for Raz-Plus and 6 licenses for Raz-Plus ELL Edition.

District Legal Counsel reviewed the Terms and Conditions and Privacy Policy and found them acceptable. Counsel has provided the vendor with an updated amendment to the agreement that covered Terms and Conditions, Renewals, Governing Law and Venue as well as SOPPA compliance. This agreement was signed and is still in place at this time.

Fiscal Impact:

\$8,992.50 for the renewal of the suite of Learning A-Z software to be used in Todd, Rutledge and Lincoln Hall from August 7, 2023 to August 7, 2024. In total the District paid Learning A-Z a total of \$8571.00 in 2022-2023)

Recommendation:

The Finance Committee concurs with the Administration to recommend to the Board of Education to approve the renewal of the Learning A-Z software in the amount of \$8,992.50 from August 7, 2023 to August 7, 2024.



Learning A-Z Quote

Date: 1/25/2023
Valid Until: 8/31/2023
Bill Id #: 10143690
Username: jstephen7

Ship To:

Jordan Stephen
 Lincolnwood School District 74
 6950 N. East Prairie Rd.
 Lincolnwood, Illinois 60712
 847-675-8234
 jstephen@sd74.org

Bill To:

Jordan Stephen
 Lincolnwood School District 74
 6950 N. East Prairie Rd.
 Lincolnwood, Illinois 60712
 847-675-8234
 jstephen@sd74.org

Products	Type	License Terms	List Price	Final Cost	Add 1 Year	Add 2 Years
ELL Edition	Renewal	6 classrooms, 12 Months	\$420.00	\$420.00	\$840.00	\$1,260.00
RAZ Plus	Renewal	27 classrooms, 12 Months	\$6,318.00	\$5,764.50	\$11,529.00	\$17,293.50
Vocabulary A-Z	Renewal	24 classrooms, 12 Months	\$2,808.00	\$2,808.00	\$5,616.00	\$8,424.00

	Final Cost	Add 1 Year	Add 2 Years
Discount Amount:	\$553.50	\$1,107.00	\$1,660.50
Sales Tax:	\$0.00	\$0.00	\$0.00
YOUR TOTAL COST:	\$8,992.50	\$17,985.00	\$26,977.50

(*) Taxes (if applicable) to be calculated at time of purchase. All prices are in U.S. dollars.

Sales Executive

Raquel Castro
raquel.castro@learninga-z.com

If paying by purchase order please send a Learning A-Z quote matching your Purchase Order (P.O.)

Email the P.O. along with the Learning A-Z quote to orders@learninga-z.com.

P.O. must include:

1. PO number
2. Learning A-Z as the vendor
3. Bill To information
4. The product(s) being purchased
5. Total dollar amount
6. If your PO has a signature line, it must be signed

Learning A-Z License Agreement

Licenses grant registered classrooms only permission to use materials on the designated website(s) during the terms of the license. Sharing user information or materials with non-registered classrooms is not authorized.

Please review our terms and conditions carefully before activating your account.

<https://help.learninga-z.com/article/Terms-of-Service>

Thank you for your business!



Sr VP of Revenue

Privacy Policy

Last Updated January 6, 2020

This Privacy Policy explains how information is collected, used, and disclosed by Learning A-Z (“Learning A-Z,” “we,” “us,” or “our”) in connection with your use of our websites, online services, and mobile applications that link to this Privacy Policy (each a “Service”; collectively, “Services”). Each time you use any Service, you consent to our collection, use, and/or disclosure of your information as described in this Privacy Policy. Each time you allow others to use any Service via your account, you confirm that you have the right to consent on their behalf to our collection, use and disclosure of their information as described in detail below. Accordingly, we urge you to read this Privacy Policy in full, as well as our [Terms of Service](#), and [contact us](#) if you have any questions.

We market and sell our products to adults who purchase or otherwise subscribe to our Services, which can then be used by children at the direction and under the supervision of these adults. We respect all of our users’ privacy, but we recognize the need to provide additional privacy protections with respect to the personal information we collect from children under 13 pursuant to the United States’ Children’s Online Privacy Protection Act of 1998 (“COPPA”). Accordingly, our privacy practices with respect to children under 13 are set forth in our [Children's Privacy Policy](#).

- **A special note to children:** If you are under 13, please get permission from your parent or legal guardian before using our Services. You must be 18 or older to purchase or otherwise subscribe to any Service. We do not market or sell to children under 18, and we seek consent from a parent or legal guardian whenever we identify that a minor attempts to purchase or register for a subscription to any Service.
- **A special note to parents:** Please help us protect your children’s privacy by instructing them never to volunteer their personal information online without your permission.

1. The Information We Collect and How We Use It

Throughout this Privacy Policy, we use the term “Personal Information” to describe

information that can be used to directly or indirectly contact or identify you, such as your full name, home or other physical address, email address, and telephone number. Personal Information also includes anonymous information that is linked to information that can be used to directly or indirectly contact or identify you. Personal Information does not include information that has been made anonymous or aggregated so that it can no longer be used, whether in combination with other information or otherwise, to contact or identify you.

We use the term “Non Personal Information” to describe information that cannot be used to directly or indirectly contact or identify you and that is not linked to information that can be used to directly or indirectly contact or identify you. Non Personal Information includes passively collected information about your activities on our Services, such as usage data, to the extent that information is not linked to your Personal Information.

1. Account Creation by Teacher and Parent Users

Teachers, parents, and other adult visitors over 18 must create accounts in order to purchase a subscription to any Service or to secure free trial access to any Service. During our online purchase process, we collect and store your first and last name, street address, email address, phone number, and school and school district. We also collect the username, password, and security question and answer you create, and if you volunteer your fax number, occupation, and class grade level, we collect and store that information. If you choose to pay with a credit card, we collect your credit card number, card type, expiration date, and security code. We transmit this payment information for processing, and we do not store this information. If you choose to pay via purchase order, check, or money order, we collect the payment information that you mail to us. If you choose to create an account for free trial access to any Service, we collect and store your full name, street address, and email address, occupation, school and school district affiliation, and username during that process. Following both account creation processes, we also collect information about whether you opt in to receive our eNews, updates, and offers.

We will not use the Personal Information collected during the account creation process for any purposes other than securing verifiable parental consent; fulfilling requested transactions; sending you order confirmations and other notifications you request or that are required by law; providing you with access to the Services, including ensuring proper licensing and providing necessary copyright permissions; and providing the customer service, technical support, and sales support you request.

2. Teacher Login Credentials

Certain of our Services—Kids A-Z, Raz-Plus, Raz-Kids, Headsprout, Science A-Z, ReadyTest A-Z, Writing A-Z, and Vocabulary A-Z—offer tools for online learning beyond downloadable resources for teachers. We offer online teacher portals, student portals, and parent portals that provide common access to all of these Services that a school district, school, teacher, or other adult has purchased.

If you are an adult with teacher access to these Services, we collect the username and password you create during the purchase process or subsequently assigned to you by your school or school district purchaser each time you login to the teacher portal. Any time you request that we reset your password, and submit your email address as part of that process, we collect your email address.

We will not use this Personal Information for any purposes other than verifying your identity and authenticating your login; facilitating your access to content; and monitoring subscription compliance. If you personally purchase access to any Service, we may use your user credentials to provide the customer service, technical support, and sales support you request. If a district, school, or other individual purchases access to any Service on your behalf, we display your login credentials on your designated Learning A-Z coordinator’s online “Accounts Site” to facilitate access to content.

3. Parent Login Credentials

If you are the parent of a child whose teacher or school has access to Kids A-Z, Raz-Plus, Raz-Kids, Headsprout, Science A-Z, ReadyTest A-Z, Writing A-Z, or Vocabulary A-Z, you may request access to the parent portal. We collect your email address in order to send you an email to allow you to create a username and password for access to the parent portal. We also collect your user credentials each time you login to the parent portal. Any time you request that we reset your password, and submit your email address as part of that process, we collect your email address.

We will not use this Personal Information for any purposes other than verifying your identity, authenticating your login, and facilitating your access to the parent portal.

4. Student Login Credentials Created by Teacher and Parent Users

Adults with teacher access to our Services that provide tools for online learning— Kids A-Z, Raz-Plus, Raz-Kids, Headsprout, Science A-Z, ReadyTest A-Z, Writing A-Z, and Vocabulary A-Z—must create a classroom roster and assign students user credentials

before students can access the Services.

We collect and store the student login credentials that you create. We will not use this Personal Information for any purpose other than providing you and your students access to the Services.

5. Account Activity by Teacher and Parent Users

If you are an adult with teacher access to our Services that provide tools for online learning, the first time you login to the teacher portal, you must enter your first and last name, class name, grade level, and school name, and we collect that information.

Once you create a classroom roster in the teacher portal, you can access classroom reports that become available as your students complete assignments in our Services. These classroom reports show the number of activities completed; each student's progress on incomplete activities; the number and time each student logged in; the bonus and incentive stars earned; student rankings; and the accuracy level for any skill group you create. If you are an adult with parent access to the Services, you can view similar reports regarding only your child's activity through the parent portal. If you have teacher access, you can review student activity on the Services; give students assignments; access student voice recordings submitted for review and grading; and send voice recordings or text messages to students. If you have parent access, you can review the activity of your child on the Services, send text messages to your child and review messages sent to your child, but you cannot give assignments.

We will not use any Personal Information we gather about you as you use the Services for any purposes other than verifying your identity and authenticating your login; facilitating your access to paid content; and monitoring subscription compliance. You control what information you provide to and about your students as you interact with the Services. If you have teacher access, the student information you provide as you use the Services should be limited to information that is relevant to the legitimate educational purpose of improving student performance. We will not ask you to enter, and you are specifically instructed not to enter, information about students that is not relevant to this legitimate educational purpose. You are also responsible for keeping the student information that you enter accurate, complete and up to date. If you recognize that student information is inaccurate, incomplete, or outdated, you are responsible for correcting it. Please note, however, that the "class chart" name that you assign to a student may be anything you choose and need not be the student's actual name. For assistance, or if you experience difficulties making corrections to student information, please [contact us](#). We will use information about students entered by teacher and parent users to provide services to your school educational institution. We will not keep such

student information after you or the school educational institution instructs us to delete it. You may not disclose or otherwise use the student data entered on this site for any unauthorized purposes.

When you are logged in to the teacher or parent portals, we automatically collect Non Personal Information about your use of the Service to support our internal operations, including information about how various features of the Service are used, what you download, and the number, frequency and length of each session. We do not combine this Non Personal Information with or link it to any of the Personal Information mentioned above.

6. Correspondence With Us

We collect and retain Personal and Non Personal Information from you when you [send us a message](#) or [chat with us](#) via our website, when you send us an email, or when you sign up for a newsletter on our [website](#). We use such information solely to provide the services or support you request.

7. Location Information

We collect and store information about your geographic location on our teacher-facing [ReadyTest A-Z](#) website, which is a Service directed to users over 13, in order to provide Texas-specific content to educators in Texas. Your location information is collected only if you enable your computer or mobile device to send us location information and/or if you expressly grant us permission to collect it by clicking “Allow” in a dialogue window that automatically pops up when you navigate to this website.

8. Automated Information

We automatically receive and record certain technical information from your browser as you use our Services, including your IP address, to improve the functionality of our Services. When we collect an IP address, we combine it with other information submitted by the user’s browser, such as requests for files from the web server. We compile this information to create access logs, which we analyze to determine trends, such as which pages are used the most, which browsers are most frequently used by visitors to access the site, and which areas of the world site users are accessing our products from most frequently. Our access logs do not contain any information which

can be uniquely associated with any particular IP address or Personal Information about any individual user.

9. *Cookies*

We use "cookies" to collect information on the non-student facing, commercial Site such as www.learninga-z.com. For example, we may use these technologies to collect information about the ways visitors use this Site - which pages they visit, which links they use, and how long they stay on each page. We also use these technologies to support certain features of this Site. For example, we use these technologies to personalize your experience when you use this Site and to save you the trouble of reentering information already in our database or to prompt the settings you established on previous visits.

The information we collect using cookies and similar technologies is not, in and of itself, personally identifiable, but we may link it to personal information that you provide. If you do not wish to receive cookies, you may set your browser to reject cookies or to alert you when a cookie is placed on your computer. Although you are not required to accept cookies when you visit this Site, you may be unable to use all of the functionality of this Site if your browser rejects our cookies.

2. **How We Share the Information We Collect**

We will not share any information collected through our Services with third parties, except as described below. We do not share Personal Information with third parties for their own marketing purposes.

1. *Personal Information*

1. Service Providers

We may share Personal Information with third-party service providers only if necessary for them to perform services on our behalf, including without limitation service providers who provide email services, process credit card payments, and provide services in support of our internal operations.

2. Corporate Affiliates and Corporate Business Transactions

We may share Personal Information with our parent company and other Learning A-Z-affiliated companies. If we enter into a business transition such as a merger, consolidation, acquisition, sale of assets, joint venture, securities offering, bankruptcy, reorganization, liquidation, or dissolution, your Personal Information may be among the assets we transfer. You acknowledge and consent that such transfers are permitted by this Privacy Policy, and that any acquirer of ours or that acquirer's affiliates may continue to collect and use your Personal Information as set forth in this Privacy Policy.

3. Legal Compliance and Security

We reserve the right to disclose Personal Information when required to do so by applicable law—for example, in response to a court order, subpoena, legal process, or other claim or inquiry. We also may disclose Personal Information in response to a law enforcement agency's request or where we believe it is necessary to investigate, prevent, or take action regarding illegal activities, suspected fraud, situations involving potential threats to the rights, property, or safety of any person, violations of our [Terms of Service](#), or to verify or enforce compliance with the policies governing our Services and applicable laws, or as otherwise required or permitted by law or legal requirements.

4. Consent

We may share your Personal Information with a third party if you consent to the sharing.

5. Authorized Educational Institutions and Third Parties They Authorize

We may disclose the information we collect about a student to authorized employees or representatives of the student's educational institution. When, at the request of the educational institution, we acquire assessment or other information, including students' Personal Information, from a third-party source, we will treat such information with the same confidentiality and security safeguards as though it were provided directly by the educational institution. Additional agreements may be required by the third party to authorize transmission of such information to us.

An educational institution may from time to time request that we provide the information

we collect about students to third parties of its choosing. We will do so only with written authorization from the educational institution that acknowledges that we are providing that information as an educational institution's agent, and that once the information is received by the third party, we no longer have any control over the use or disposition of the information. If a written request to disclose the Personal Information of students to a third party is provided to us, the educational institution releases us from all responsibility over the use or disposition of such information.

Upon written request by an educational institution, we will destroy any information collected from students for educational institutions who no longer participate in our Services. We will also provide written verification that the data has been destroyed as requested. If an educational institution has not used any Service for a period of ten years, upon request, we will provide written notice that the student information pertaining to their educational institution will be destroyed unless the educational institution requests the records be kept.

2. Non Personal Information

This Privacy Policy does not limit our use of any Non Personal Information, and we reserve the right to use and disclose such information to third parties at our discretion. However, in the event that we wish to release Non Personal Information that identifies a school or educational institution by name, we will enter into a separate agreement with a school or school district purchaser to authorize release and publication.

3. Districts and School Systems

Under the terms of our contracts with schools, we agree to act as a "School Official" as defined by the Family Educational Rights and Privacy Act ("FERPA"), meaning that we:

- Perform an institutional service or function for which the school or district would otherwise use its own employees;
- Have been determined to meet the criteria set forth in the school's or district's annual notification of FERPA rights for being a School Official with a legitimate educational interest in the education records;
- Are under the direct control of the school or district with regard to the use and maintenance of education records; and
- Use education records only for authorized purposes and will not re-disclose from education records to other parties (unless we have specific authorization from the school or district to do so and it is otherwise permitted by FERPA).

4. Account Holders' Communication Choices

We provide you the ability to exercise certain controls and choices regarding our collection, use and disclosure of your information. If you opt in to receive our eNews, updates, and offers, you consent to receive certain email communications from us, which may include newsletters, administrative notices, and special offers. You have a choice at any time to stop us from sending you emails for marketing purposes by updating your email [preferences](#).

Please note that, despite any indicated email marketing preferences, we may still send you administrative emails regarding the operation of our Services.

5. Changing or Removing Personal Information and Closing Accounts

1. Reviewing Your Own Information

If the Personal Information you provided when you created an account changes, you must promptly notify us of those changes. You have the right to access, update and correct factual inaccuracies in the Personal Information that we collect through our Services, subject to certain exceptions. If you want to access, update, or correct your Personal Information, simply edit your profile in your [My Account](#) section. To help protect your privacy and the security of your Personal Information, we may request information from you to enable us to confirm your identity and right to access such information, as well as to search for and provide you with the Personal Information that we maintain. For information about how to review the Personal Information we collect from children under 13, please see our Children's Privacy Policy section below.

There are instances where applicable law or regulatory requirements allow or require us to refuse to provide some or all of the Personal Information that we hold about you. In addition, your Personal Information may have been destroyed, erased or made anonymous in accordance with our record retention obligations and practices. In the event that we cannot provide you with access to your Personal Information, we will endeavor to inform you of the reasons why, subject to any legal or regulatory restrictions.

If you no longer wish to have your information collected by an application installed on a mobile device, you may uninstall the application by using the standard uninstall processes available on the mobile device or via the mobile application marketplace or network.

2. *Closing Accounts*

If you no longer wish to use our Services, you may close your account by [contacting us](#). Adults with teacher access may remove a student account by deleting the student from their classroom roster. Adults with parent access may do this by contacting the account holder, such as the school, to request deletion of their child's information. The school may contact Learning A-Z at support@learninga-z.com by call 1-866-889-3729.

If you close your account, we have no obligation to retain your information, and we may delete any or all of your information without liability. However, we may retain information related to you if we believe it may be necessary to prevent fraud or future abuse, if required by law, or for legitimate business purposes, such as analysis of aggregated, Non Personal Information, account recovery, auditing our records, and enforcing our rights and obligations under our agreements. We disclaim any liability in relation to the deletion or retention (subject to the terms of this Privacy Policy) of information or any obligation not to delete your information.

6. Using the Services Outside the United States

We are based in the United States, and the information we collect is governed by and operated in accordance with United States law. If you are using the Services outside the United States, you consent to having your information and data transferred to the United States. While users from countries other than the United States may access certain of our Services, we make no representation that the Services are operated in accordance with the laws or regulations of, or governed by, other nations. If you are from any jurisdiction with laws or regulations governing the use of the Internet, including the collection, use and disclosure of Personal Information, that are different from those of the United States, you may only use the Services in a manner lawful in your jurisdiction.

7. How We Protect Information

We use reasonable technical, administrative, and physical security measures designed to safeguard and help prevent unauthorized access to your information, maintain data security, and correctly use the information we collect. These measures include, but are not limited to, the use of encryption, physical access controls, information access controls, and anti-virus and anti-malware software.

Additionally, your account is protected by the password you use to access your online account, and we urge you to take steps to keep your username and password safe. Teacher and parent users are responsible for maintaining the confidentiality of their usernames and passwords, including student usernames and passwords. If you feel your password or a password of a student user has been compromised, you should change it

immediately. When you are finished using our Services, you should log out of your account and exit your browser. Teacher and parent users are also responsible for notifying us immediately of any known or suspected unauthorized use(s) of account, or any known or suspected breach of security, including loss, theft, or unauthorized disclosure of login credentials. Any fraudulent, abusive, or otherwise illegal activity on your account may be reported to appropriate law enforcement agencies by us.

Please be aware that, despite our best efforts, no security measures are perfect or impenetrable. We cannot guarantee or warrant the security of any information you disclose or transmit to us on or through the Services and cannot be responsible for the theft, destruction, loss or inadvertent disclosure of your information.

8. Links to Other Websites

We may provide links to other websites that we believe may be of interest to our users. However, we are not responsible for the privacy practices employed by those websites, nor are we responsible for the information or content they contain. This Privacy Policy applies solely to information collected by us through our Services; thus, when you use a link to navigate to a third-party website, this Privacy Policy is no longer in effect. We encourage our users to read the privacy policies of these other websites before proceeding to use them.

9. Contact Us

Teachers, parents, and other adult visitors over 18 with questions or comments regarding this Privacy Policy may contact us using the information below:

- Attn: Customer Service Manager
- Email: support@learninga-z.com; COPPAPrivacy@ikeepSAFE.org
- Phone: 1-866-889-3729
- Address:

LEARNING A-Z
1840 E RIVER RD STE 220
TUCSON AZ 85718-5997
USA

10. Changes to This Privacy Policy

We may periodically make changes to this Privacy Policy, including changes to keep pace with changing technology and as new or changed Services are released. We expect most such changes to be minor. Any non-material changes will take effect immediately

upon posting of an updated Privacy Policy on our Services. You should periodically check our Privacy Policy for updates. However, there may be cases where changes to the Privacy Policy may be more significant. In such cases, we will first provide notice to users who are affected. If we make changes to this Privacy Policy that may affect our collection or use of Personal Information from children under 13, we will give notice and obtain the prior verifiable consent of a parent or legal guardian. See our [Children's Privacy Policy](#) for more information about those practices.

Your continued use of the Services after the effective date of the Privacy Policy will constitute acceptance of any changes. If you do not agree to the revised Privacy Policy, please refrain from using the Services.

Terms of Service

Last Updated July 31, 2020

Learning A-Z Terms of Service

PLEASE READ THESE TERMS AND CONDITIONS CAREFULLY BEFORE ACTIVATING YOUR ACCOUNT.

1. ACCEPTANCE OF TERMS

Learning A-Z provides its services on any purchased website to you, subject to the following Terms of Service ("TOS"), which may be updated from time to time. Please bookmark this page to review the most current version of the TOS at any time. Your use of any purchased website and its materials constitutes your agreement to all such terms, conditions, policies, and notices (the "Agreement"). This Agreement is a legal document that governs the terms and conditions of your subscription to Learning A-Z. You are also agreeing to accept a non-exclusive, non-assignable right and license to use Learning A-Z and its resources. Learning A-Z is offered and sold on a subscription basis; however, certain areas are available to visitors without cost on a trial or demonstration basis.

2. DESCRIPTION OF SERVICE

Learning A-Z provides users with access to a rich collection of teaching resources through its collection of websites (the "Service"): Reading A-Z, Raz-Kids, Headsprout, Science A-Z, Writing A-Z, Vocabulary A-Z, and ReadyTest A-Z. Unless explicitly stated otherwise, any new features that augment or enhance the current Service, including the release of new resources, shall be subject to the TOS. You understand and agree that the Service is provided "AS-IS" and that Learning A-Z assumes no responsibility for the timeliness, deletion, mis-delivery, or failure to store any user communications or personalization settings.

You are responsible for obtaining access to the Service, and that access may involve third-party fees (such as Internet service provider or airtime charges). You are responsible for those fees. In addition, you must provide and are responsible for all equipment necessary to access the Service.

3. LICENSE USAGE

A license grants access to the purchased Learning A-Z website as well as permission to use its copyrighted resources as part of the classroom curriculum. Each educator using the resources must have a license in order to obtain the necessary permission. Each Learning A-Z license is valid for one family or classroom only (with up to 36 students).

If your family or classroom has less than 36 students, it is not permitted to share a license with another family or classroom. Purchasers of Learning A-Z Licenses may not resale, distribute or otherwise share classroom seats to parties outside of the individual classroom or family for which the license is purchased. Licenses must be maintained for continued permission to use downloaded, copyrighted materials. Each license must be registered in the name of the classroom teacher using the resources.

As part of the registration process, each educator will select, or be provided with, a username and password ("Username"). You agree to provide us with accurate, complete, unique and updated contact information for each educator using downloaded resources or accessing the website(s). Failure to do so will constitute a breach of this Agreement, which may result in immediate termination of your rights to use the resources or access the account. You may not (a) select or use a Username of another person with the intent to impersonate that person, (b) use a name subject to the rights of any other person without written authorization from that individual, or (c) use a Username that we, in our sole discretion, deem inappropriate or offensive. You are responsible for maintaining the confidentiality of your username and password, and you will be responsible for all uses of your username and password, whether or not authorized by you.

In order to access the Service, or use its downloaded resources, you need to obtain a username and password ("Username"). Usernames are either selected by, or issued to, individual subscribers or educators within a learning institution (collectively, "Users") as part of the registration process. You agree to provide us with accurate, complete, unique and updated contact information for each educator using downloaded resources or accessing the Services. Failure to do so will constitute a breach of this Agreement, which may result in immediate termination of your rights to use the resources or access the account. You may not (a) select or use a Username of another person with the intent to impersonate that person, (b) use a name subject to the rights of any other person without written authorization from that individual, or (c) use a Username that we, in our sole discretion, deem inappropriate or offensive. You are responsible for maintaining the confidentiality of your username and password, and you will be responsible for all uses of your username and password, whether or not authorized by you.

You also agree that Usernames may not be shared within anyone outside the registered classroom and/or family. They may only be used by the administrator, educator, or student to whom they are assigned. Users remain at all times solely and fully responsible for the proper use of Usernames issued hereunder. Users also agree to supervise and take full responsibility for the use of the Website by minors under the age of 13 years.

All Users are entirely liable for all activities conducted through that Account, and are responsible for ensuring that any other person within the registered classroom and/or family who uses the Account is aware of, and complies with, the terms of this Agreement. Each person who uses the Account agrees to be bound by the terms of this

Agreement, whether or not such person is a Member.

You are responsible for notifying us immediately of any known or suspected unauthorized use(s) of your Account, or any known or suspected breach of security, including loss, theft, or unauthorized disclosure of your Username. You must also promptly change your Username to prevent unauthorized access to your Account. We will have no liability for any circumstances arising from the unauthorized use of a Username or your Account. Any fraudulent, abusive, or otherwise illegal activity on your Account may be reported to appropriate law-enforcement agencies by us.

4. MODIFICATIONS TO SERVICE

Learning A-Z reserves the right at any time and from time to time to modify or discontinue, temporarily or permanently, the Service (or any part thereof) with or without notice. You agree that Learning A-Z shall not be liable to you or to any third party for any modification, suspension, or discontinuance of the Service.

Learning A-Z may change, add, or remove any part of this Agreement, or any other terms associated with the use of the website, at any time, by posting a notice of such changes to the Terms of Service page of the website. Any changes shall become part of the Agreement and shall apply as soon as such a notice is posted. By continuing to use the services after the notice is posted, you are indicating your acceptance of those changes.

5. SPONSORS, THIRD PARTIES, AND ADVERTISERS

Your correspondence or business dealings with, or participation in promotions of, sponsors, third parties, or advertisers found on or through the Service, including payment and delivery of related goods or services, and any other terms, conditions, warranties, or representations associated with such dealings, are solely between you and such sponsor, third party, or advertiser. You agree that Learning A-Z shall not be responsible or liable for any loss or damage of any sort incurred as the result of any such dealings or as the result of the presence of such sponsors, third parties, or advertisers on the Service.

6. LINKS

Learning A-Z may provide, or third parties may provide, links to other websites or Internet resources. Because Learning A-Z has no control over such websites and resources, you acknowledge and agree that Learning A-Z is not responsible for the availability of such external websites or resources, and does not endorse and is not responsible or liable for any content, accuracy, quality, advertising, products, or other materials on, or available from, such websites or resources. You further acknowledge and agree that Learning A-Z shall not be responsible or liable, directly or indirectly, for any damage or loss caused, or alleged to be caused by or in connection with use of, or reliance on, any such content, goods, or services available on, or through any such website or resource.

7. DISCLAIMER OF WARRANTIES

YOU EXPRESSLY UNDERSTAND AND AGREE THAT:

- a. YOUR USE OF THE SERVICE IS AT YOUR SOLE RISK. THE SERVICE IS PROVIDED ON AN "AS IS" AND "AS AVAILABLE" BASIS. LEARNING A-Z EXPRESSLY DISCLAIMS ALL WARRANTIES OF ANY KIND, WHETHER EXPRESSED OR IMPLIED, INCLUDING, BUT NOT LIMITED TO THE IMPLIED WARRANTIES OF MERCHANTABILITY, FITNESS FOR A PARTICULAR PURPOSE AND NON-INFRINGEMENT.
- b. LEARNING A-Z MAKES NO WARRANTY THAT (I) THE SERVICE WILL MEET YOUR REQUIREMENTS, (II) THE SERVICE WILL BE UNINTERRUPTED, TIMELY, SECURE, OR ERROR-FREE, (III) THE RESULTS THAT MAY BE OBTAINED FROM THE USE OF THE SERVICE WILL BE ACCURATE OR RELIABLE, (IV) THE QUALITY OF ANY PRODUCTS, SERVICES, INFORMATION, OR OTHER MATERIAL PURCHASED OR OBTAINED BY YOU THROUGH THE SERVICE WILL MEET YOUR EXPECTATIONS, (V) ANY ERRORS IN THE SOFTWARE WILL BE CORRECTED, (VI) OR THAT THIS WEBSITE, ITS CONTENT, AND THE SERVERS ON WHICH THE WEBSITE AND CONTENT ARE AVAILABLE ARE FREE OF VIRUSES OR OTHER HARMFUL COMPONENTS.
- c. ANY MATERIAL DOWNLOADED OR OTHERWISE OBTAINED THROUGH THE USE OF THE SERVICE IS DONE AT YOUR OWN DISCRETION AND RISK AND THAT YOU WILL BE SOLELY RESPONSIBLE FOR ANY DAMAGE TO YOUR COMPUTER SYSTEM OR LOSS OF DATA THAT RESULTS FROM THE DOWNLOAD OF ANY SUCH MATERIAL.
- d. NO ADVICE OR INFORMATION, WHETHER ORAL OR WRITTEN, OBTAINED BY YOU FROM LEARNING A-Z OR THROUGH, OR FROM, THE SERVICE SHALL CREATE ANY WARRANTY NOT EXPRESSLY STATED IN THE TOS.
- e. INFORMATION CREATED BY THIRD PARTIES THAT YOU MAY ACCESS ON THE WEBSITE OR THROUGH LINKS IS NOT ADOPTED OR ENDORSED BY LEARNING A-Z AND REMAINS THE RESPONSIBILITY OF SUCH THIRD PARTIES.

8. LIMITATION OF LIABILITY

YOU EXPRESSLY UNDERSTAND AND AGREE THAT LEARNING A-Z SHALL NOT BE LIABLE FOR ANY DIRECT, INDIRECT, INCIDENTAL, SPECIAL, CONSEQUENTIAL OR EXEMPLARY DAMAGES, INCLUDING BUT NOT LIMITED TO, DAMAGES FOR LOSS OF PROFITS, GOODWILL, USE, DATA OR OTHER INTANGIBLE LOSSES (EVEN IF LEARNING A-Z HAS BEEN ADVISED

OF THE POSSIBILITY OF SUCH DAMAGES), RESULTING FROM: (I) THE USE OR THE INABILITY TO USE THE SERVICE; (II) THE COST OF PROCUREMENT OF SUBSTITUTE GOODS AND SERVICES RESULTING FROM ANY GOODS, DATA, INFORMATION OR SERVICES PURCHASED OR OBTAINED OR MESSAGES RECEIVED OR TRANSACTIONS ENTERED INTO THROUGH OR FROM THE SERVICE; (III) UNAUTHORIZED ACCESS TO OR ALTERATION OF YOUR TRANSMISSIONS OR DATA; (IV) STATEMENTS OR CONDUCT OF ANY THIRD PARTY ON THE SERVICE; OR (V) ANY OTHER MATTER RELATING TO THE SERVICE. IN NO EVENT SHALL LEARNING A-Z'S TOTAL LIABILITY TO YOU FOR ALL DAMAGES, LOSSES, AND CAUSES OF ACTION, WHETHER IN CONTRACT, NEGLIGENCE, TORT OR OTHERWISE EXCEED THE AMOUNT PAID BY YOU, IF ANY, FOR ACCESSING LEARNING A-Z.

9. EXCLUSIONS AND LIMITATIONS

SOME JURISDICTIONS DO NOT ALLOW THE EXCLUSION OF CERTAIN WARRANTIES OR THE LIMITATION OR EXCLUSION OF LIABILITY FOR INCIDENTAL OR CONSEQUENTIAL DAMAGES. ACCORDINGLY, SOME OF THE ABOVE LIMITATIONS OF SECTIONS 6 AND 7 MAY NOT APPLY TO YOU.

10. TRADEMARK INFORMATION

All materials on the Learning A-Z websites, including without limitation, names, logos, trademarks, service marks, images, graphics, photographs, illustrations, artwork, and other elements making up the Service are protected by copyrights and other intellectual property rights owned and controlled by Learning A-Z or by other parties that have licensed their material to Learning A-Z. EXCEPT AS SPECIFICALLY PROVIDED HEREIN, no Online Materials may be republished, posted, transmitted, or distributed in any way, or otherwise used for any purpose, without the prior written permission of their respective owners. You may not add, delete, distort, or otherwise modify any Learning A-Z content. Any unauthorized attempt to modify any Online Material, to defeat security features, or to utilize this website for means other than its intended purposes is prohibited.

Learning A-Z logos and product and service names are trademarks of Cambium Learning, Inc. All other trademarks appearing on the website are trademarks of their respective owners and our reference to them does not imply or indicate any approval or endorsement by their owners unless such approval or endorsement is expressly made. Learning A-Z will enforce its intellectual property rights to the fullest extent of the law.

If you suspect that the content or trademarks of a Learning A-Z website product are being misused please [contact us](#) as soon as possible.

11. NON-WAIVER

The failure of Learning A-Z to exercise or enforce any right or provision of the TOS shall not constitute a waiver of such right or provision. If any provision of the TOS is found by

a court of competent jurisdiction to be invalid, the parties nevertheless agree that the court should endeavor to give effect to the parties' intentions as reflected in the provision, and the other provisions of the TOS remain in full force and effect. You agree that regardless of any statute or law to the contrary, any claim or cause of action arising out of, or related to, use of the Service or the TOS must be filed within one (1) year after such claim or cause of action arose or be forever barred.

12. HEADINGS FOR CONVENIENCE ONLY

The section titles in the TOS are for convenience only and have no legal or contractual effect.

13. VIOLATIONS

Please [contact us](#) immediately to report any violations.

14. INDEMNIFICATION

You agree to indemnify, defend, and hold Learning A-Z harmless from any claims and expenses, including reasonable attorneys' fees, arising from or related to any breach by you of any terms of this Agreement.

15. LETTERS, REVIEWS, OR OTHER SUCH COMMENTS OR MATERIALS

Any comments, materials, or letters sent by you to Learning A-Z, including without limitation, questions, comments, suggestions, criticisms or the like ("Received Materials") shall be deemed to be non-confidential and free of any claims of proprietary or personal rights unless you explicitly state in the correspondence that the letter is "not for publication" and contains "private and proprietary" information that may not be distributed. Learning A-Z shall have no obligation of any kind with respect to such Received Materials and Learning A-Z will be free to reproduce, use, disclose, exhibit, display, transform, edit, abridge, create derivative works from, and/or distribute, the Received Materials without limitation or restriction. Furthermore, Learning A-Z is free to use any ideas, concepts, know-how, or techniques contained in any communication you send to Learning A-Z for any purpose whatsoever, including, but not limited to, developing, manufacturing, and marketing products using such information, without compensation or any other obligations to anyone, including you.

16. PRIVACY

Learning A-Z is committed to protecting the privacy of website visitors and does not share personally identifiable information with third parties without your consent. Please consult our [Privacy Policy](#) for more information on our information collection, use and disclosure practices. You acknowledge that, although Learning A-Z agrees to use its best efforts to comply with and to ensure that its users, content providers, distributors and licensees comply with our Privacy Policy, Learning A-Z cannot be held responsible for the actions of third parties who violate our Privacy Policy.

17. RESTRICTIONS ON USE

You may not use Learning A-Z or its content for any illegal purpose or in any manner inconsistent with these Terms and Conditions. You agree to use Learning A-Z solely for your own noncommercial use and benefit and not for resale or other transfer or disposition to any other person or entity.

Permitted Use: You have our permission to print a reasonable number of copies of Learning A-Z content displayed on the Website for noncommercial personal or classroom use, provided that any copies you print continue to show all notices concerning copyright, trademark and other proprietary rights that appear in the material you reproduce and do not exceed the classroom license set forth in Section 3.

Prohibited Uses: Except as expressly permitted by copyright law and except as permitted in the preceding paragraph, you must obtain written permission from Learning A-Z, or the third-party owner of material appearing on the Website, for any other copying, redistributing or publishing of any Learning A-Z or "Third Party Content." The downloading of any code from the Website is strictly prohibited. You may not modify, publish, transmit, participate in the transfer or sale of, reproduce, create derivative works from, distribute, perform, display or in any way exploit, any of the Learning A-Z or Third Party Content, in whole or in part, for commercial purposes without the express permission of Learning A-Z.

Linking to and framing the Website: You may create and publish links to any LearningA-Z.com homepage. Creating and publishing links to any other pages within the Website (except bookmarking such pages for your personal noncommercial use) is not permitted. Framing the Website is strictly prohibited.

Additional Restrictions: You may not: (a) access the Website by any means other than by means supporting secure and encrypted communications; (b) copy, reverse engineer, disassemble, decompile, translate, or modify any Website application or service; (c) sublicense, rent, lease, or permit any third party, to access any Website application or service through the use of User's Username, except as permitted hereunder; (d) publish the results of benchmark tests of any Website application or service, or use any Website application in any manner which is competitive with services provided by Learning A-Z; and (e) knowingly use or permit any others to use any facilities or services of Learning A-Z or its Licensors in connection with any effort that the User knows seeks to breach the security or confidentiality of any other digital or on-line environment.

Users understand that except for Learning A-Z Content, Learning A-Z does not control, provide, operate, and is not responsible for, any content, goods or services available on the Internet other than the Learning A-Z Content on the Website. Internet content made accessible on the Internet by independent third parties is not part of, and is not controlled by, Learning A-Z. Learning A-Z neither endorses nor is responsible for the accuracy or

reliability of such Internet content, goods or services.

Users should be aware that the Internet contains content, goods and services that you may find obscene, improper, hurtful or otherwise offensive and that may not be suitable for certain users of the Website. Because of the nature of the Internet, we cannot control where children may go while using the Website. Parents, guardians or teachers should supervise children when using the Website and the Internet at all times.

Any unauthorized use may subject you to civil liability and criminal prosecution under applicable laws. In the event you download Content from Learning A-Z, the software, including any files, images incorporated in or generated by the software and data that may accompany the Content are licensed to you by Learning A-Z. Learning A-Z, or our contract partners, does not transfer title to the Content to you. Learning A-Z, or our contract partners, retains full and complete title to the Content and all intellectual property rights therein. You may not redistribute, sell, decompile, reverse-engineer or disassemble the Content.

18. SEVERABILITY

In the event any provision of this Agreement conflicts with the law or if any such provisions are held invalid by a court with jurisdiction over the parties to this Agreement, such provision will be deemed to be restated to reflect as nearly as possible the original intentions of the parties in accordance with applicable law, and the remainder of this Agreement will remain in full force and effect.

19. ENTIRE AGREEMENT

This Agreement and any other terms and conditions of service on a Learning A-Z website constitute the entire agreement between you and Learning A-Z and govern your use of the Service.

20. REFUSAL OR DISCONTINUANCE OF SERVICE

In the event that Learning A-Z determines, in its sole discretion, that a User has breached any portion of these terms and conditions, or has otherwise demonstrated inappropriate conduct, it reserves the right to (i) warn the User via e-mail that she or he has violated this Agreement; (ii) delete any content provided by the User (or anyone accessing User's account); (iii) discontinue the User's account and/or any other Learning A-Z service; (iv) notify and/or send content to and/or fully cooperate with the proper law enforcement authorities for further action; (v) retroactively charge for the unauthorized use; and/or (vi) take any other action that Learning A-Z deems appropriate.

21. CHOICE OF LAW AND FORUM

The laws of the State of Texas will govern this Agreement. The laws of the State of Texas will govern any dispute arising from the terms of this agreement or breach of this agreement and you agree to personal jurisdiction by the state and federal courts sitting in

Dallas, Texas. The parties hereby expressly waive trial by jury in any action, proceeding or counterclaim brought by either of the parties against the other on any matters whatsoever arising out of, or in any way connected with, these Terms and Conditions and agree to submit to binding arbitration. Learning A-Z makes no representation that materials on Learning A-Z are appropriate or available for use in all locations. Those who choose to access Learning A-Z do so on their own initiative and are responsible for compliance with local laws, if and to the extent local laws are applicable. Materials from Learning A-Z are further subject to United States export controls. No materials from Learning A-Z may be downloaded or otherwise exported or re-exported (i) into (or to a national or resident of) Cuba, Iran, Iraq, Libya, North Korea, Syria, Venezuela or any other country to which the United States has embargoed goods; or (ii) to anyone on the U.S. Treasury Department's list of Specially Designated Nationals or the U.S. Commerce Department's Table of Deny Orders. By downloading or using the materials, you represent and warrant that you are not located in, under the control of, or a national or resident of any such country or on any such list.



Executive Summary Board of Education Meeting

DATE: June 1, 2023

TOPIC: 2023-2028 Finalsite Inc. Website and Hosting Services Contract

BY: Jordan Stephen

Recommended for:

- Action
- Discussion
- Information

Purpose/Background:

Lincolnwood School District 74 has subscribed to Blackboard Inc. for many years and used its services for hosting the school District and School websites and mobile app services. Last year, during the time of our annual contract renewal, the company was purchased by Finalsite, which is another major player in the school website hosting and design space, hosting over 5000 school Districts in the states and around the globe.

Finalsite is currently offering all former Blackboard customers the opportunity for a free conversion to one of the new customized responsive design templates. By signing up with a renewal and conversion, this will save the District thousands of dollars in future design and setup fees. Through this opportunity, the District will be able to take advantage of new technologies and ensure that our future website is compliant with ADA regulations. Samples of future templates are included in this packet which will be headed by our Director of Communications and Community Relations Taskforce. Finalsite has presented the District with a multiyear commitment in which we can lock in our pricing with small annual increases of \$200 over the next 5 years.

District Legal Counsel has reviewed the new Terms and Conditions and Privacy Policy and found them to be standard, but lacking a few details. Counsel has offered our standard Amendment to the vendor which covers auto renewals, indemnification, court and venue, liability and SOPPA language. The vendor has a copy of the Amendment to be reviewed by their legal team, but it has not been endorsed at this time. Currently the District does have a vendor specific Data Privacy Agreement that has been signed by the vendor which is necessitated by the Student Online Personal Protection Act (SOPPA) that outlines details of data privacy.

Fiscal Impact:

\$2,229. The District paid \$2072.42 during the 2022-23 school year to Blackboard Inc. for website and mobile app and hosting services. The proposed 5-year quote starts at \$2,229 for year 1, \$2,429 for year 2, \$2,629 for year 3, \$2,829 for year 4 and \$3,029 for year 5.

Recommendation:

The Finance Committee concurs with the Administration to recommend to the Board of Education to approve the Finalsite Contract for design services, setup fees, website hosting for the proposed 5-year quote in the amount of: \$2,229 for school year 2023-24, \$2,429 for school year 2024-25, \$2,629 for school year 2025-26, \$2,829 for school year 2026-27 and \$3,029 for school year 2027-28.

Sample Templates:

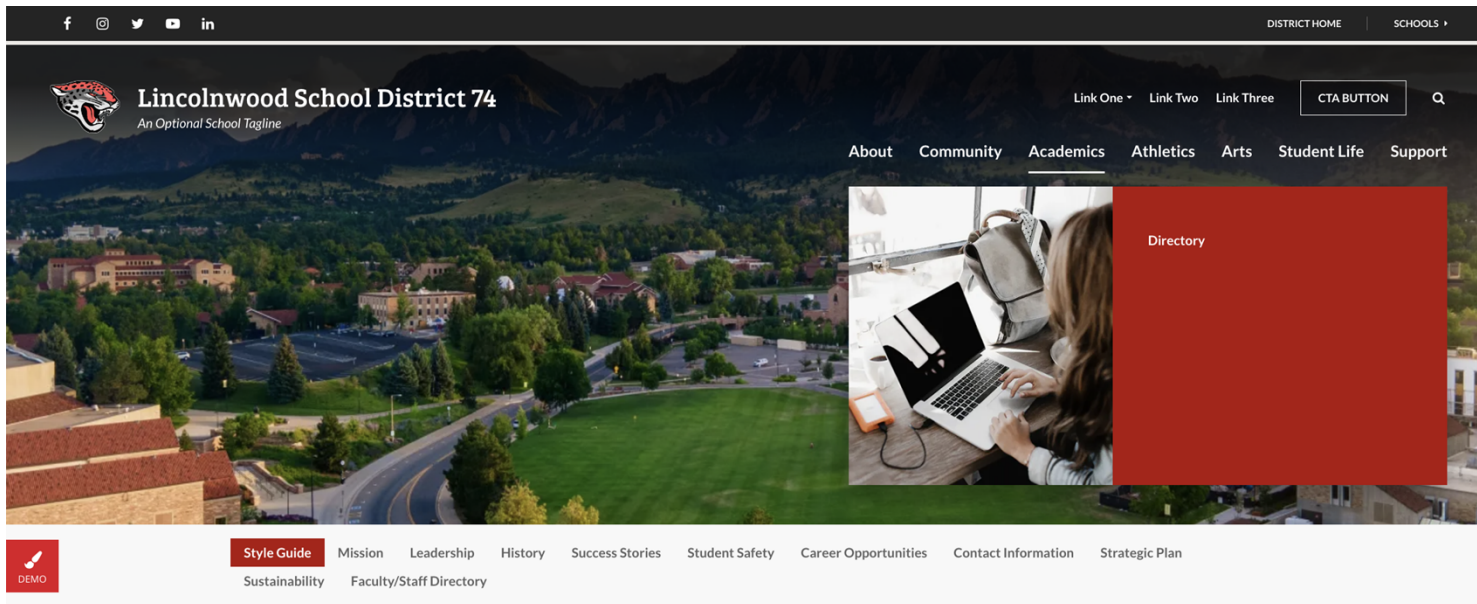

CANTON > STYLE GUIDE

Style Guide

Lead In Style maecenas faucibus mollis interdum. Praesent commodo cursus magna vel scelerisque nisl consectetur et.

Body Paragraph Style cras justo odio, dapibus ac facilisis in, egestas eget quam. Lorem ipsum dolor sit amet, consectetur adipiscing elit.

Integer posuere erat a ante venenatis dapibus posuere velit aliquet. Donec ullamcorper nulla non metus auctor fringilla. Nulla vitae elit libero, a pharetra augue.

[Hyperlink](#)

Heading Two

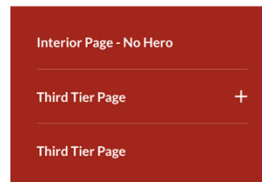

English



Link Section

Praesent commodo cursus magna, vel scelerisque nisl consectetur et.

FIND OUT MORE >

Cras Pharetra Cursus

Morbi leo risus, porta ac consectetur ac, vestibulum at eros.



Community Child 1

Community Child 4

Community Child 2

Community Child 5

Community Child 3



DEMO

Photo Title Displayed Here

Optional description lorem ipsum dolor sit amet, consectetur adipiscing elit. Vivamus sagittis lacus vel augue laoreet rutrum faucibus dolor auctor fusce dapibus, tellus ac cursus commodo.

CTA BUTTON





-  BOARD MEETING AGENDA
-  ENROLLMENT
-  CAREERS
-  PARENT UNIVERSITY
-  LOCAL CONTROL AND ACCOUNTABILITY
-  SAY SOMETHING ANONYMOUS REPORTING

News

  ALL NEWS 



April 27, 2023

 English > Dates and Times



April 27, 2023

Teacher Earns National

Calendar

  ALL EVENTS 

MAY
10

- California Day of the Teacher
- 🕒 all day



FINALSITE ORDER

This Finalsite Order (the “**Order**”) is entered into by and between Active Internet Technologies, dba Finalsite (“**Finalsite**”) and Lincolnwood School District 74 (“**Customer**”) and sets forth the terms of Customer’s use of the products and services set forth below (“**Pricing Summary**”). This Order, together with the Master Terms and Conditions for Services (the “**Master Terms**”) located at <http://www.finalsite.com/masterterms/useducationagencies> and incorporated herein by this reference, form the entire agreement between the parties in respect of the products and services set forth below. Each of the individuals executing this Order represent and warrant that he or she is authorized to execute this Order on behalf of Customer or Finalsite, as applicable. Unless otherwise specified herein, any capitalized terms used in this Order shall have the meaning defined in the Master Terms. The “**Effective Date**” of this Order is the date on which both parties have signed this Order as reflected in the signature lines below.

In consideration of the promises set forth herein, and other good and valuable consideration, the receipt of which are hereby acknowledged, the parties hereby agree as follows:

A. Pricing Summary

Creative and Deployment Services Package
Blackboard WCM Composer Upgrade The Statement of Work ('SOW') for this Creative Services Package can be reviewed here https://www.finalsite.com/sow-wcm-conv

Composer CMS Platform
Core Communications Platform - Blackboard WCM Conversion View a detailed description of what's included in your software package here https://www.finalsite.com/wcm-conv-pkg

Products Included in Communications Core Platform - Blackboard WCM Conversion	
Finalsite Composer Content Management System	Granular Permissions
Admin Users, Editors (12)	HTTPS Implementation
Admins with ticketing rights (4)	Knowledge Base and Product Training Resources
Basic Integrated Site Search	Mobile Friendly, Responsive Designs
Calendar Manager	News / Blogs via Posts (16 boards pooled)
Website cloud storage / 50 GB	Page Based Notifications (Unlimited)
Comprehensive Training Program	Published Pages (Unlimited)
Content Migration for Tiers 1, 2, 3	Resources (Media, Galleries, Document Library)
District Site and 3 Additional Sites	Secure Hosting & CDN
Drag - and - Drop Page Elements	Single Sign-On
Faculty / Staff Directory (public facing)	Social Media Feeds for Districts - Standard (4)
Faculty / Staff Portal	Standard Support Plan
Forms Manager (16 forms pooled)	

Additional Products or Services:

Modules

Posts for Teacher Pages	
-------------------------	--

Community Engagement Products:

*[x] indicates product removed * Indicates products added*

Mobile Communications App	
MOBILE COMMUNICATIONS APP	

Web Community Manager	
WCM ESSENTIAL	

Services: Initial Term and Fees:

The initial term of this Order is for the (5) year period beginning from the Effective Date, unless otherwise outlined in the schedule below (the "Initial Term").

Fees for the Initial Term for the Services specified in the table above are set forth below:

Total Setup Cost (USD)
\$ 0

Schedule	Amount
Period 1 - Jul 01 2023	\$ 2,229
Period 2 - Jul 01 2024	\$ 2,429
Period 3 - Jul 01 2025	\$ 2,629
Period 4 - Jul 01 2026	\$ 2,829
Period 5 - Jul 01 2027	\$ 3,029

B. Payment Terms

1. All fees for the initial year of this Order shall be due as follows: (i) Set Up fees shall be invoiced on the Effective Date of this Order and shall be due and payable upon receipt of invoice; (ii) fees for Year 1 (described in the fee table above) shall be invoiced on the Effective Date of this Order or the first day of Year 1, whichever is later, and shall be due and payable upon receipt of invoice; (iii) fees for each subsequent Year of the Initial Term, and for each Renewal Term, shall be invoiced on the commencement of such Year or Renewal Term (as applicable) and shall be due and payable upon receipt of invoice. Fees for any other Services, and for reimbursable expenses, shall be invoiced in accordance with the Master Terms or this Order and shall be due and payable upon receipt of invoice.
2. Unless otherwise specified in the Special Provisions above, this Order Form shall be renewed automatically for successive periods of (5) years (each a "Renewal Term") after the expiration of the Initial Term and any subsequent Renewal Term, unless Client provides AIT, or AIT provides Client, with a written notice to the contrary ninety (90) days prior to the end of the Initial Term or Renewal Term, as applicable.
3. Unless otherwise specified, all dollars (\$) are United States currency.
4. Sales/VAT Tax: If applicable, a copy of Customer's Sales/VAT Tax Direct Pay Certificate or its Sales/VAT Tax Exemption Certificate must be returned with this Order Form. Otherwise, Finalsite will invoice Customer for applicable sales, use and other transactional taxes due in connection with the Services or the fees due therefor.
5. Except as otherwise specified in this Order, fees are subject to increase in accordance with the applicable provisions of the Master Terms.

By signing below, Finalsite and Customer each agree to the terms and conditions of this Order and the Master Terms.

Client: Lincolnwood School District 74
Signature
Name (printed)
Title (printed)
Date

Active Internet Technologies ("AIT")
Signature 
Name (printed) Jim Calabrese
Title (printed) CFO
Date 4/7/2023

As the Customer Contact, by initialing in this box, I agree on behalf of Customer that I have read the Statement of Work ('SOW') and understand the expected deliverables for Finalsite as well as for Customer's project team. I understand that the project timeline is a good faith estimate which is dependent on, among other factors, Customer's ability to meet respective Customer tasks and deadlines.

C. Client Contact Information

Please fill out the following information, which will be used by our deployment & accounting teams.

Billing Contact
Title
Address 6950 N East Prairie Rd
City, State Zip Lincolnwood, IL 60712-2554
Phone
Email

Project Contact
Title
Phone
Email

*Executive Sponsor (Superintendent, Head of School, CFO, etc.)
Title
Email

*The Executive Sponsor should be separate from the Project Contact and is typically the Superintendent, Head of School, Business Manager, CFO, etc.

Finalsite Master Terms and Conditions

U.S. EDUCATION AGENCIES

THESE MASTER TERMS AND CONDITIONS (“MASTER TERMS”) APPLY TO ALL SERVICES MADE AVAILABLE TO THE CUSTOMER BY ACTIVE INTERNET TECHNOLOGIES, LLC, dba FINALSITE, A CONNECTICUT CORPORATION HAVING A PRINCIPAL PLACE OF BUSINESS AT 655 WINDING BROOK DRIVE, GLASTONBURY, CONNECTICUT 06033 AND ITS OPERATING AFFILIATES INCLUDING SCHOOLADMIN LLC, SCHOOLPOINT, INC. AND FINALSITE HOLDINGS (UK) LIMITED (COLLECTIVELY, “FINALSITE”). THE “CUSTOMER” IS A SCHOOL DISTRICT OR OTHER EDUCATION AGENCY WHICH ENTERS INTO AN ORDER WITH FINALSITE PURSUANT TO THESE MASTER TERMS. EACH ORDER EXECUTED BY THE PARTIES FORMS A SEPARATE CONTRACT BETWEEN WHICH INCORPORATES AND IS GOVERNED BY THESE MASTER TERMS (FINALSITE AND CUSTOMER ARE SOMETIMES COLLECTIVELY REFERRED TO AS THE “PARTIES”).

These Master Terms, together with each fully executed Order and Statement of Work, any applicable Services Rider containing terms and conditions specific to any Services and any additional contract documents agreed in writing between the Parties, such as student data privacy addenda required by applicable law to the extent not otherwise addressed in the Privacy Terms (collectively, the “Customer Contract Documents”), forms the contract between Finalsite and the Customer (collectively, the “Agreement”).

In the event of any conflict between the terms and conditions of these Master Terms and the terms and conditions of any Order, the terms and conditions of the Order shall control with respect to such Order. In the event of any conflict between the terms and conditions of these Master Terms and the terms and conditions of any Services Rider, the terms and conditions of the Services Rider shall control with respect to the relevant Services. **In the event of any conflict between the terms and conditions of these Master Terms and the terms and conditions of the Customer Contract Documents, the terms and conditions of the Customer Contract Documents shall control.**

1. Ordering Services.

1.1 Services Generally. Finalsite agrees to provide the Customer the services (collectively, “Services”) described in a mutually agreed ordering document signed by the Parties (each an “Order”). Services may include access to certain software applications and other technology of Finalsite, including hosting, regular support and maintenance any and all regular updates, enhancements, error corrections, bug fixes, and modifications which are made generally available by Finalsite to its customers (collectively, “SaaS Services”) and certain professional services, including deployment of the SaaS Services and other professional services, such as website design, training and consulting services (collectively, “Professional Services”). Specific Services are also subject to the terms and conditions included in the Order. The Customer shall only have the right to receive those Services specified in the relevant Order during the duration stated therein. Subject to the terms and conditions of this Agreement, Finalsite shall make the relevant Services available to the Customer on the Effective Date of the applicable Order. In the course of Finalsite providing Services, Finalsite may utilize its employees, affiliates, subcontractors and third party service providers (“Representatives”) to provide their services to Finalsite as part of Finalsite’s provision of Services to the Customer. Finalsite’s Representatives include third parties who provide back-up, hosting, support and business recovery services. Finalsite remains

responsible for the acts of its Representatives under this Agreement.

2. Usage Rights and Restrictions.

2.1 Usage Rights – SaaS Services. Subject to the terms of this Agreement, Finalsite grants the Customer the right to access and use the SaaS Services described in each Order solely by the Customer’s employees, faculty, administrators, students, parents of students, alumni and/or third party service providers who are authorized by the Customer to use the SaaS Services on the Customer’s behalf (collectively, “Authorized Users”). With respect to public-facing content which the SaaS Services display on behalf of the Customer, Authorized Users include individuals who access screen displays of the SaaS Services on a remote, web-enabled basis in order to view the content which the Customer has chosen to display to the public. The Customer and its Authorized Users shall access the SaaS Services solely via Finalsite’ hosted portal. The Customer shall have no other access to any Finalsite technology and shall not be entitled to download or otherwise receive a copy of the SaaS Services. Due to the nature of a SaaS delivery model, the SaaS Services to which the Customer is provided access will be the then-current version of such SaaS Services which is made available by Finalsite to its customers generally. The Customer shall be liable for the acts and omissions of its Authorized Users relating to this Agreement and use of

the SaaS Services. Finalsite reserves to itself all rights not expressly granted pursuant to this Agreement.

2.2 Restrictions. The Customer and its Authorized Users shall not (i) access or use the Services beyond the term and specific scope limitations forth in the relevant Order; (ii) modify, copy, transfer, translate or create any derivative works based on the SaaS Services; (iii) override or attempt to override or circumvent any security feature, control or usage limits with respect to the SaaS Services; (iv) remove or alter any copyright notices, trademarks or other proprietary rights notices contained on or within (or in any materials provided by Finalsite in connection with) the Services; (v) resell or sublicense the Services or use the SaaS Services to provide any services on behalf of any third parties; (vi) violate any applicable law, regulation, order, decree or judgment in connection with the use of the Services, including any content and data utilized thereby; (vii) use or knowingly permit the use of any security testing tools in order to probe, scan or attempt to penetrate or ascertain the security of the SaaS Services, Finalsite's systems or any software applications deployed by or accessible via integration with Finalsite; or (viii) attempt to gain access to the SaaS Services or any Finalsite systems in a manner not expressly authorized in the Agreement. The Customer shall take all reasonable precautions to prevent any virus or other malicious code from compromising the SaaS Services and/or Finalsite systems, including implementing other industry-standard security protections for any browsers used to access the SaaS Services. The Customer shall only enable access to and allow use of the Services in accordance with the express terms of the Agreement. Additional usage limitations or restrictions may be imposed on the Customer's use of the Services in the relevant Order, including limitations on bandwidth and storage.

2.3 Analytics. The Customer acknowledges that Finalsite may track usage of the SaaS Services by the Customer and its Authorized Users (by use of Google Analytics and other similar means) for purposes of providing, enhancing and maintaining its service offerings, collecting and analyzing cookies and other metadata, for analytical, statistical or benchmarking purposes and for creating analytics related to the use of the SaaS Services by Finalsite customers ("Analytics Data"). Analytics Data is created and maintained on an anonymized basis and does not identify individual data subjects. All right, title and ownership of Analytics Data (including all derivative works thereof) is and shall remain solely and exclusively vested in Finalsite.

3. Service Levels.

3.1 Finalsite will provide the SaaS Services in accordance with the Service Level Agreement ("SLA") available at <https://www.finalsite.com/servicelevels>, as may be amended from time to time in a manner that does not materially degrade the service levels set forth therein.

4. Professional Services.

4.1 Statement(s) of Work. The Parties may also enter into a Statement of Work (each, a "SOW") to describe the scope of certain Professional Services and specific terms and dependencies relating to those Professional Services. In order to be effective, a SOW must be signed by both Parties and reference the applicable Order. Any modifications or changes to the Services following execution of a SOW must be evidenced by a mutually acceptable amendment signed by both Parties.

4.2 Limitations/ Cooperation. Any timetable set forth in a SOW, Order or other project document is a good faith estimate which is dependent on, among other factors, the Customer's provision of appropriate information, cooperation, assistance, and tasks, including those items which may be identified as the responsibility of the Customer in the SOW. Subject to Section 7.02 of these Master Terms, the Customer shall provide Finalsite access to the Customer's logos and trademarks and other content as may be necessary Finalsite to perform the Professional Services described in an Order.

4.3 Professional Services Representations and Warranties. Finalsite will provide all Professional Services in a professional and workmanlike manner and in accordance with any and all descriptions or requirements set forth in an applicable SOW. If deliverables are provided as part of the Professional Services and those deliverables do not conform in all material respects to any applicable specifications and other requirements described in the applicable Order or SOW, the Customer shall give Finalsite written notification of the deficiency or non-conformance within thirty (30) days after delivery of such Services. Finalsite then shall, within thirty (30) days of receipt of such written notification, use commercially reasonable efforts to correct the deficiency. The Customer shall provide such support and assistance as reasonably requested by Finalsite to discover the cause or a cure for the reported deficiency or non-conformance.

4.4 E-Verify. Finalsite agrees that it shall register with and use the U.S. Department of Homeland Security's E-Verify system, <https://e-verify.uscis.gov/emp>, to verify the work authorization status of all newly hired employees engaged to perform Professional Services during the term of this Agreement.

4.5 Conflicts of Interest/ Anti-Corruption. Finalsite agrees that it will not knowingly engage in transactions which conflict with the interests of the Customer and shall abide by a high standard of ethical conduct in the formation of this Agreement and providing Services hereunder. In particular, Finalsite will not pay kickbacks directly or indirectly to any Customer employee for the purpose of obtaining this or any other agreement with the Customer and agrees to cooperate fully with any investigation involving a possible violation of this Section. Finalsite has provided Customer's employees or Representatives no fees, gifts, gratuities, compensation, or anything of value in violation of applicable law in connection with this Agreement.

5. Maintenance and Support.

5.1 Scope. Finalsite shall provide maintenance and support of the SaaS Services, including provision of and all regular updates, enhancements, error corrections, bug fixes and modifications to the SaaS Services in accordance with Finalsite's then-current standard support policies and practices as and when made available to customers generally. Finalsite supports the Customer's browser access to the SaaS Services utilizing the then-current version and one prior version of Internet Explorer, Safari, Chrome or Firefox. Certain Support Services are accessible through the "Help" section located in the Customer's interface to the SaaS Services. Finalsite reserves the right to discontinue any Service during the Term for any reason, but in such event Finalsite will notify Customer and, as Customer's sole and exclusive remedy, Finalsite will provide a pro-rata refund for any unused portion of the discontinued Services.

5.2 Enhanced Support. Certain support Services (such as expedited or "priority" support) may be purchased by the Customer under an Order, and, in such event, the terms and conditions of such Support Services, and associated fees, shall be as described in the applicable Order.

6. Third Party Technology.

6.1 Third Party Technology. Finalsite may utilize certain software or other technology of third parties (collectively, "Third Party Technology") in connection with its provision of the SaaS Services. The SaaS Services may be used to enable the Customer to interact with and/or utilize certain Third Party Technology, such as payment processing, online chat services, site translation services, accessibility overlay solutions, font and typography services, and any web service, website, social media platform or online library that enables functionality within a webpage displayed by the SaaS Services. Finalsite shall be responsible for enabling interoperability between the SaaS Services and the Third Party Technology described in

the relevant Order. Except for the foregoing, the Customer is solely responsible and liable for the Customer's access to or use of any Third Party Technology.

7. Ownership.

7.1 Customer Materials. As between the Customer and Finalsite, Customer Materials are the sole and exclusive property of Customer. "Customer Materials" means, collectively, all data and materials (including text and images) that the Customer and its Authorized Users input, post, submit, or otherwise provide to Finalsite while utilizing the Services and in connection with Finalsite's provision of Services under this Agreement; and Customer's logos and trademarks. The Customer shall be solely responsible and liable for the content, accuracy or completeness of all Customer Materials (including monitoring the content of Customer Materials posted on the SaaS Services), and for any infringement of any third party intellectual property rights resulting from by any Customer Materials.

7.2 Use of Customer Materials. During the Term of this Agreement, Customer grants to Finalsite and its Representatives a non-exclusive, royalty-free license to access, modify, reproduce, display, combine, copy, store, transmit, distribute, and otherwise use the Customer Materials for purposes of performing Finalsite's obligations hereunder. Subject to the terms of the Agreement and to the extent permitted by applicable law, Customer authorizes Finalsite and its Representatives to access and process Customer Materials in countries other than the jurisdiction from which the Customer Materials were originally collected. Finalsite shall not use Customer Materials except as authorized under this Agreement (including the applicable DPA) and to the extent required, or permitted, by applicable laws or regulations.

7.3 Services. As between the Customer and Finalsite, Finalsite owns all right, title, and interest in and to: (a) the SaaS Services, including the underlying software applications and technology and all application program interfaces ("API's") provided or made available by Finalsite in connection therewith; (b) all documentation, materials, work product and deliverables resulting from or related to the Services; and (c) all enhancements, modifications, updates, upgrades and derivative works thereof and all Intellectual Property Rights in any of the foregoing. Any enhancements, modifications, derivative works or any other intellectual property created directly or indirectly using or referring to the SaaS Services or components thereof, whether created solely by the Customer, a third party on behalf of the Customer, or jointly by the Customer and Finalsite or a third party on

either party's behalf, belong exclusively to Finalsite, and the Customer hereby irrevocably assigns all rights therein, including all Intellectual Property Rights to Finalsite. For purposes of these Master Terms, "Intellectual Property Rights" means collectively all intellectual or industrial property rights recognized now or in the future under the laws of any jurisdiction throughout the world, including trademarks and trade mark applications, trade names, service marks, patents and patent applications, copyrights, and trade secrets in each case, including any registrations of, applications to register, and renewals and extensions of, any of the foregoing and derivative works and improvements (as such terms are defined and applied under Title 17 and Title 35 U.S.C., respectively).

7.4 Content Restrictions. Customer agrees not to use any Service to store, display, or transmit content that is deceptive, libelous, defamatory, obscene, racist, hateful, infringing or illegal, and to the extent Authorized Users exercise the rights granted to you under this Agreement, Customer represents and agrees that it will ensure that its Authorized Users will also comply with the obligations applicable to such exercise set forth in this Agreement. Finalsite takes no responsibility and assumes no liability for any Customer Materials that it, or any Authorized User, or third party out of our control posts, submits, displays, or otherwise makes available via any Service, and Customer agrees Finalsite is acting only as a passive conduit for the online distribution and publications of such Customer Materials.

7.5 Removal of Content. If Finalsite determines in good faith that any Customer Materials could (a) pose a material security risk, (b) be deceptive or perceived as libelous, defamatory, obscene, racist, hateful, or otherwise objectionable, or (c) give rise to potential liability to Finalsite or a violation of applicable law or the terms or restrictions of the Agreement, then we may remove the offending Customer Materials, suspend Customer's and/or your Authorized Users' use of the Services, and/or pursue other remedies and corrective actions.

7.6 Other Rights. Customer hereby grants Finalsite a limited right and license to use Customer's name, logo and/or other marks for the sole purpose of listing Customer as a user of the applicable Services in promotional materials unless and until Customer provides a written request to discontinue such use.

7.7 Feedback. In the event that the Customer or any of its Authorized Users submit any ideas, suggestions, proposed enhancements, or other feedback relating to the SaaS Services (collectively, "Feedback"), Finalsite shall own all such Feedback without compensation to the

Customer or its Authorized Users and the Customer hereby irrevocably assigns all rights, including any Intellectual Property Rights, in such Feedback to Finalsite.

8. Protection of Personal Information.

8.1 Provision of Personal Information. In connection with use of the Services set forth in an Order, the Customer and its Authorized Users may from time to time provide Finalsite with certain personally identifiable information of the Customer's students, prospective students, parents of students, faculty, administrators, employees and/or Authorized Users that is protected by various laws and regulations ("Personal Information").

8.2 Data Protection and other Compliance Obligations. Both parties shall comply with their respective obligations under applicable data privacy laws with respect to Personal Information, including the Family Educational Rights and Privacy Act of 1974, 20 USC 1232g and its implementing regulations, as they may be amended from time to time ("FERPA"), the Protection of Pupil Rights Amendment ("PPRA"), and COPPA. Finalsite will maintain reasonable and appropriate security measures designed to protect Personal Information from unauthorized access, destruction, use, modification and disclosure.

8.3 Customer Data Privacy Obligations. The Customer shall maintain reasonable and appropriate security measures to protect the confidentiality and integrity of its account IDs, passwords, and interaction with the SaaS Services. The Customer shall be responsible for all account activities regardless of whether the activities are authorized by the Customer or undertaken by the Customer, its employees and other Representatives or Authorized Users and Finalsite is not responsible for unauthorized access to your account. The Customer shall also comply with all applicable laws and regulatory requirements governing Personal Information utilized and transferred in connection with the SaaS Services.

9. Additional Data Privacy Terms.

9.1 Student Data. Personal Information of students, student records and student-generated content (collectively, "Student Data") is the property of the applicable student or legal guardian of the student. During the Term of this Agreement, the Customer shall retain control of all Student Data maintained in connection with the Services. Finalsite shall take reasonable commercial measures designed to ensure the security and confidentiality of all Student Data. Finalsite and its employees, agents and contractors shall use Student Data only for purposes for which it may utilize Customer Materials under the terms of this Agreement.

9.2 FERPA. Student Data may include “education records” as defined under FERPA. To the extent that Finalsite collects or processes Personal Information in education records in the course of providing Services under this Agreement, it does so as an outsourced institutional function pursuant to FERPA 34 CFR Part 99.31(a)(1) and is designated by the Customer for these purposes as a “school official” with legitimate educational interests. In this regard, Finalsite will comply with its responsibilities as a school official under FERPA. Similarly, the Customer will comply with the responsibilities applicable to it under FERPA. The Customer is responsible to obtain any necessary consents prior to providing Student Data to Finalsite and is wholly responsible for providing annual notice to students and parents or other legal guardians of their rights with respect to FERPA and other applicable law.

9.3 Additional Data Processing Terms. Additional data processing terms applicable to your jurisdiction are available at <https://www.finalsite.com/dpa> (each, a “DPA”) and are incorporated into and made a part of these Master Terms. Finalsite may amend or supplement any DPA from time to time to address current best practice or to address changes in applicable law. Such additional terms will become part of this Agreement unless Customer objects in writing within ten (10) days of any posted update, provided that any changes required by law shall become part of this Agreement immediately upon the effective date of such change.

10. Consent to Use/Transfer

10.1 Consents. The Customer represents and warrants that at all times during the Term, it has obtained all consents necessary for Finalsite to access and use the Customer Materials and Student Data for purposes of providing the Services, including those consents related to the collection, use, maintenance and transfer of Personal Information (including Student Data) in compliance with applicable law and regulatory requirements (including the Children’s Online Privacy Protection Act, as amended). Finalsite may rely on this Agreement as the Customer’s representation that all necessary consents have been obtained and Finalsite shall not be required to independently verify such fact or compliance by the Customer with applicable law with respect thereto.

10.2 Authorized Use. The Customer further represents and warrants that the use of Personal Information and other Customer Materials by Finalsite, in accordance with the terms of the Agreement, does not and will not violate any applicable law or regulatory requirements, or result in the breach of any covenant or obligation that the Customer has to any person or entity. The Customer

acknowledges that Finalsite has no responsibility to review or monitor any Customer Materials, including reviewing or determining the legality, accuracy or completeness of Customer Materials. Finalsite, however, reserves the right to take any action with respect to the Services that Finalsite deems necessary or appropriate in its sole discretion if Finalsite reasonably believes the Customer’s use of the Services could violate applicable law or regulatory requirements, create liability for Finalsite, its affiliates and/or its suppliers, or could otherwise compromise or disrupt services provided to other customers.

11. Customer Responsibilities.

11.1 Hardware and Customer Procedures. In addition to its other responsibilities as set forth in this Agreement, the Customer is solely responsible for and assumes all liability relating to (i) decisions about the Customer’s computer and communications systems needed to access the SaaS Services; (ii) all purchases of any necessary hardware, software, services or licenses required by the Customer to access and use the SaaS Services as contemplated in this Agreement; (iii) the Customer’s procedures and criteria, including any claim by an applicant, student, parent or employee arising from the Customer’s procedures or criteria and any violation of any applicable statutory or regulatory requirements resulting from implementation of the Customer’s procedures and criteria; and (iv) provision and maintenance of all domains and URLs used by the Customer and its Authorized Users to access the Services.

11.2 Compliance with Law. The Customer and its Authorized Users shall comply with all applicable law and regulatory requirements in their respective execution, delivery and performance of this Agreement and access to and use of the Services.

11.3 Terms of Use. Access and use of the Services is contingent upon compliance with the terms and conditions of this Agreement. The Customer warrants and covenants that neither the Customer or its Authorized Users will: (i) use the Services, in whole or in part, to store, initiate or transmit material (including Customer Materials) that is infringing, libelous, defamatory, abusive, harmful to minors, designed to cause annoyance, inconvenience or distress to any person; comprises unsolicited marketing in violation of third-party privacy or property rights, or otherwise violate applicable law; (ii) interfere with, unreasonably burden, or disrupt the integrity or performance of the Services or third-party data or content contained therein; (iii) attempt to gain unauthorized access to the Services or its related systems or networks; or (iv) provide the Services to third parties

who are not Authorized Users, including, by resale, license, loan or lease. The Customer will use best efforts to prevent and/or block any prohibited use, and will cooperate with Finalsite to prevent or cease such use from continuing. The Customer will notify Finalsite in writing, within three (3) business days of discovery of facts indicating that the Services are being used in violation of the Agreement or applicable law, describing such violation(s), and the basis for such knowledge, and shall fully cooperate with Finalsite to remedy such violation. The Customer shall be solely responsible and liable for such violative use.

12. Term of the Agreement/Orders.

12.1 Term. This Agreement shall become effective on the effective date of the first Order entered into by the Customer and Finalsite and shall continue through the termination date of all Orders hereunder (the "Initial Term"), unless terminated earlier in accordance with the provisions of this Agreement. The term of any Order shall be stated in the Order, provided however that unless otherwise provided in any Order, the term of each Order shall automatically renew for successive terms of equal duration to the initial term stated therein (each, a "Renewal Term"), unless either Party provides written notice of its intent not to renew at least ninety (90) days prior to the expiration of the then-current term. The Initial term and all Renewal Terms are collectively referred to as the "Term".

13. Termination

13.1 Uncured Breach. In the event either party defaults in any obligation in this Agreement or any Order, the non-defaulting Party shall give written notice of such default. If the Party in default has not cured the default within thirty (30) days of receipt of the notice, the non-defaulting Party may terminate this Agreement by delivering written notice thereof to the defaulting Party.

13.2 Insolvency. Either Party may terminate this Agreement, effective immediately upon written notice, in the event that the other party: (i) makes a general assignment for the benefit of creditors; (ii) institutes proceedings seeking relief or reorganization under any laws relating to bankruptcy or insolvency or (iii) has a court of competent jurisdiction appoint a receiver, liquidator or trustee over all or substantially all of such party's property or provides for the liquidation of such Party's property or business affairs.

13.3 Inactivity. Either party may terminate this Agreement upon written notice at any time when there are no Orders then in effect. In addition, this Agreement

shall automatically expire if there are no Orders or SOWs Work in effect for a continuous period of six (6) months.

13.4 Convenience. The Customer shall have the right to terminate any Order for convenience, contingent upon satisfying the following conditions: (i) the Customer must provide Finalsite with at least ninety (90) days' prior written notice of termination of the applicable Order, including the effective date of termination; and (ii) the Customer must pay Finalsite (on or before the effective date of termination), one hundred percent (100%) of all remaining fees due under the terminated Order as of the effective date of such termination, in addition to actual expenses incurred by Finalsite as of the termination date.

13.5 Termination for Lack of Funding. The Customer represents that it has sufficient available funds to pay for the Services purchased under each Order through at least the end of the then-current fiscal year. If sufficient funds are not appropriated by the Customer's public funding body to pay in full the fees due under such Order for any fiscal year thereafter during which an Order is in effect, then the Customer shall have the right to terminate the relevant Order by providing Finalsite written notice of termination at least ninety (90) days prior to the first day of the fiscal year for which sufficient funds will not be available and by paying Finalsite in full for all fees and expenses due through the end of the then-current fiscal year. The Customer agrees that the termination rights set forth in this Section 13.5 will not apply if funds are appropriated to it for the acquisition, retention or operation of software or other services substantially similar to the Services provided by Finalsite under this Agreement. The Customer agrees to use its best efforts to obtain and maintain sufficient funds to make all payments due hereunder and commits that it will only utilize this provision in the event that, despite its good faith best efforts to continue to fund all Orders under this Agreement, such funds are not appropriated by the relevant funding body.

13.6 Effects of Termination. Termination of this Agreement or any Order shall terminate all Services provided by Finalsite thereunder without the requirement of additional notice by Finalsite, and the Customer and its Authorized Users shall cease all use of the applicable Services on or before the effective date of termination or expiration. The due dates of all payments owed by the Customer to Finalsite under this Agreement shall become due on the effective date of termination or expiration.

14. Subcontractors.

14.1 Use of Third Party Contractors. Subject to the term of this Agreement, including the relevant DPA and applicable law, Finalsite may utilize third party

subcontractors and/or subprocessors in its sole discretion to perform, or support performance of, any Services under this Agreement. In such event, Finalsite shall not be relieved from its obligations under this Agreement. A current list of subprocessors utilized by Finalsite in provision of Services can be found at <https://www.finalsite.com/subprocessors>.

15. Fees and Expenses

15.1 Fees. All fees and expenses payable by the Customer shall be payable in the amounts and on such payment dates as described in the applicable Order. The Customer may ACH or wire payments or pay via check. If the Customer elects to pay via check, the check must be drawn on a U.S. bank. Fees stated in any Order are fixed for the current term of the Order for the scope of Services described in such Order. Thereafter, Finalsite may increase fees for any Renewal Term effective as of the commencement of such renewal term by providing at least thirty (30) days' advance written notice to the Customer of the increase. Any requested changes to the scope of Services requested by the Customer shall be subject to additional fees, which shall be reflected in an amendment to the existing Order or a new Order executed by the Parties. All amounts payable by the Customer under this Agreement will be paid to Finalsite without setoff or counterclaim, and without any deduction or withholding. All fees are non-refundable.

15.2 Expenses. In addition to obligation to pay fees, the Customer shall reimburse Finalsite for all travel and other out-of-pocket expenses reasonably incurred by Finalsite in rendering Services to the Customer under any SOW. Except as described in a SOW, all such expenses shall be payable by the Customer upon execution of the relevant SOW.

15.3 Payment Terms. All Services fees are payable annually in advance. Payment for the invoice covering the first year of any Order is due upon execution of the relevant Order. Thereafter, Finalsite will invoice the Customer for each subsequent annual period on each annual anniversary of the effective date of the relevant Order. All invoices under any Order shall be due and payable within thirty (30) days of invoice date. After thirty (30) days from the invoice date, Finalsite may charge interest at the rate of 1.5% per month, or the highest rate allowed by applicable law, whichever is less, on all overdue unpaid amounts until payment is received by Finalsite. All fees incurred by Finalsite for collections (including attorneys' fees and costs) must be paid or reimbursed by the Customer. All invoices shall be sent to the Customer at the billing address set forth in the Order.

15.4 Suspension for Non-Payment. In the event the Customer fails to pay any amounts owing under any Order for sixty (60) days from date of invoice, without limiting its other rights and remedies, Finalsite may suspend Services to the Customer until such amounts are paid in full. Finalsite will provide the Customer prior notice that the Customer's account is overdue before suspending Services.

15.5 Taxes. The Customer shall be responsible for the payment of, or reimbursement of Finalsite for, any applicable present or future services, sales, use, excise, goods, property, value added or other taxes or duties levied against or upon the provision of SaaS Services (excluding taxes based upon Finalsite's net income). Upon request, the Customer will provide Finalsite with a valid tax exemption certificate authorized by the appropriate taxing authority.

16. Confidentiality

16.1 Confidential Information. In the course of performance of this Agreement, the Parties may receive or have access to information that is confidential to one or the other Party and a Party's Authorized Users (collectively, "Confidential Information"). Confidential Information shall mean non-public materials and information, in whatever form, written, oral or otherwise, that include, but shall not be limited to (i) the SaaS Services, including any modules, functionality or content licensed by Finalsite from third parties; (ii) the distinctive methods or procedures which Finalsite uses in the design, development, licensing, support, or maintenance of the SaaS Services, (iii) each Party's business processes and strategies, (v) all portions of the Customer Materials which are treated as confidential by the Customer; (vi) all Personal Information; and (v) all information clearly identified by either Party as confidential, provided however that a party's Confidential Information shall not include information that: (a) is or becomes generally available to the public through no act or omission of the other Party; (b) was in the other Party's lawful possession prior to the disclosure and had not been obtained by the other Party either directly or indirectly from the disclosing Party or from a third party whom the receiving Party knows or should know is under an obligation of confidentiality with the owner of the Confidential Information; (c) is lawfully disclosed to the other Party by a third party without restriction on disclosure; or (d) is independently developed by the other Party.

16.2 Restrictions on Use and Disclosure. Each Party agrees to hold the other Party's Confidential Information in confidence during the Term of this Agreement and following termination for any reason. Except for

disclosure to Finalsite's subcontractors and third party service providers who are bound by confidentiality obligations with respect to such Confidential Information and as otherwise provided in the Agreement, each Party agrees not to make the other Party's Confidential Information available in any form to any third party or to use the other Party's Confidential Information for any purpose not intended under this Agreement. Each Party agrees to take all reasonable steps to ensure that Confidential Information is not disclosed or distributed by any person or entity in violation of the terms of this Agreement. Following receipt of a written request and promptly following termination of this Agreement, the other Party shall return to the requesting Party, in whole or in part, the Confidential Information that has been disclosed in tangible form. Each Party may retain a copy of Confidential Information solely for archival purposes.

16.3 Public Records Law. The Customer's obligations under this Section 16 are subject to the state public records laws of the state of the Customer's formation to the extent applicable, *provided that*: (i) the Customer shall provide Finalsite prompt written notice of any public records requests for disclosure of this Agreement and/or any materials and information relating to this Agreement, Finalsite Confidential Information and/or deployment of Finalsite's technology, including Finalsite's responses to any Request for Proposal issued by the Customer; (ii) allow Finalsite to claim any exceptions from disclosure it deems appropriate under applicable law, at Finalsite's cost and expense; and (iii) reasonably cooperate with Finalsite in such efforts.

17. Representations, Warranties & Disclaimers

17.1 Services Warranties. Finalsite warrants to the Customer that during the Term of the Agreement: (i) all Professional Services will be performed in a professional manner, with the requisite level of qualifications, care and skill, exercised consistent with standard industry practices; and (ii) the features and functions of the SaaS Services will comply in all material respects with the description(s) set forth in the applicable standard user guides and administrative guides when used and/or accessed in accordance with the terms and conditions of this Agreement and the applicable Order. The Customer must provide written notice to Finalsite of any alleged defects and the Customer's sole remedy will be for Finalsite to promptly provide modifications or fixes with respect to the applicable non-conformity.

Unless the Customer provides written notice to Finalsite within ten (10) business days following completion of any Professional Services, any claims of breach of warranty

with respect to such Professional Services and resulting work product shall be deemed waived.

17.2 Exclusions. The foregoing are excluded from the foregoing services warranties and Finalsite shall not be liable for: (i) the Customer's or its Authorized Users' use and/or access the SaaS Services in a manner which is not in conformance with the terms and conditions of this Agreement and relevant Order; (ii) the Customer's or its Authorized Users' use the SaaS Services with third party data, software or hardware which is incompatible with the SaaS Services; (iii) errors in the SaaS Services resulting from the Customer's or its Representatives' or Authorized Users' configuration or manipulation of the SaaS Services, in each case not specifically recommended in writing by Finalsite; or (iv) reduced performance or non-availability of the SaaS Services resulting from failure of network connections.

17.3 Debarment. Finalsite represents and warrants that neither it, nor to its knowledge, any of its respective employees or other Representatives engaged in the provision of Services under this Agreement have been excluded, debarred, suspended or otherwise deemed ineligible to participate in Federal, state or other U.S. governmental programs, nor is it, or to its knowledge its respective employees or other Representatives, included on the list of sanctioned parties maintained by the U.S. government, including, without limitation, the List of Specially Designated Nationals and Blocked Persons and Foreign Sanctions Evaders List maintained by the U.S. Department of the Treasury's Office of Foreign Assets Control, the Office of Inspector General, the General Services Administration, or any other state or federal governmental agency.

17.4 Finalsite Validity/ Non-contravention Warranties. Finalsite represents, warrants and covenants that: (i) this Agreement constitutes the valid and binding agreement of Finalsite, duly authorized by all necessary action on the part of Finalsite; and (ii) the execution, performance and delivery of this Agreement by Finalsite are within Finalsite's corporate powers and do not and will not violate (a) the articles of incorporation or bylaws of Finalsite, (b) any law, rule, regulation, judgment, order or decree applicable to Finalsite's performance of its obligations hereunder or contravene or cause a default under any license, franchise, permit or other similar authorization held by Finalsite, or any agreement to which Finalsite is a party, or (c) require the consent or other action of any person or entity which has not been obtained prior to execution of this Agreement.

17.5 Customer Validity/ Non-contravention Warranties. the Customer represents, warrants and covenants that: (i)

this Agreement constitutes the valid and binding agreement of the Customer, duly authorized by all necessary action on the part of the Customer and its governing body; (ii) the Customer has full authority to execute and perform its obligations as contemplated by this Agreement; and (iii) the execution, performance and delivery of this Agreement by the Customer are within the Customer's organizational powers, have been duly authorized by all necessary action on the part of the Customer, and do not and will not violate (a) the applicable organizational documents of the Customer, (b) any applicable law, regulatory requirement, judgment, order or decree or cause a default under any license, franchise, permit or other similar authorization held by the Customer, or any agreement to which the Customer is a party, or (c) require the consent or other action of any person or entity (including in respect of, or filing with, any governmental body, agency or official) which has not been obtained prior to execution of this Agreement. The Customer has provided Finalsite evidence of approval by all governing bodies as required by applicable state law prior to execution of the Agreement.

17.6 Disclaimers. It is the Customer's sole responsibility to determine the suitability of the Services for the Customer's use. EXCEPT AS EXPRESSLY STATED IN THIS AGREEMENT, AND TO THE MAXIMUM EXTENT PERMITTED UNDER APPLICABLE LAW, FINALSITE AND ITS LICENSORS MAKE NO, AND HEREBY DISCLAIM ANY, REPRESENTATION, WARRANTY OR GUARANTY, WHETHER EXPRESS, IMPLIED, STATUTORY OR OTHERWISE, WITH RESPECT TO THE SERVICES PROVIDED UNDER THIS AGREEMENT, INCLUDING WITHOUT LIMITATION, ANY IMPLIED WARRANTY: (1) OF MERCHANTABILITY; (2) OF FITNESS FOR A PARTICULAR PURPOSE; (3) ARISING FROM COURSE OF PERFORMANCE, COURSE OF DEALING, OR USAGE OF TRADE; OR (4) OF NON-INFRINGEMENT OF THIRD PARTY RIGHTS. EXCEPT AS SET FORTH IN THIS SECTION, THE SERVICES ARE PROVIDED "AS IS", WITHOUT ANY FURTHER WARRANTIES OF ANY KIND. FINALSITE AND ITS LICENSORS MAKE NO WARRANTY THAT OPERATION OF THE SAAS SERVICES WILL BE UNINTERRUPTED OR ERROR FREE OR THAT ALL DEFECTS WILL BE CORRECTED. FINALSITE AND ITS LICENSORS MAKE NO, AND HEREBY DISCLAIM ANY, REPRESENTATION, WARRANTY OR GUARANTY, WHETHER EXPRESS, IMPLIED, STATUTORY OR OTHERWISE, REGARDING ANY THIRD PARTY TECHNOLOGY.

17.7 Liability Limits. EXCEPT TO THE EXTENT EXPRESSLY PROHIBITED BY LAW, EXCEPT FOR AMOUNTS OWED BY CUSTOMER UNDER THIS AGREEMENT, FOR ALL CLAIMS BY A PARTY, WHETHER SUCH CLAIMS ARE MADE IN CONTRACT, TORT, OR OTHERWISE, A PARTY'S POTENTIAL RECOVERY SHALL BE LIMITED TO THE ACTUAL, DIRECT

DAMAGES SUFFERED BY SUCH PARTY UP TO THE ACTUAL AMOUNT PAID OR PAYABLE BY CUSTOMER TO FINALSITE UNDER THE ORDER UNDER WHICH THE CLAIM AROSE DURING THE TWELVE (12) MONTHS PRIOR TO THE INITIAL ASSERTION OF CLAIM(S) FOR THE SPECIFIC SERVICE(S) GIVING RISE TO SUCH CLAIM(S).

17.8 Waiver of Indirect Damages. EXCEPT TO THE EXTENT EXPRESSLY PROHIBITED BY LAW, IN NO EVENT SHALL A PARTY (IN THE CASE OF FINALITE INCLUDING ITS SUPPLIERS, LICENSORS, SERVICE PROVIDERS AND/OR SUBCONTRACTORS) BE LIABLE FOR ANY INDIRECT, INCIDENTAL, PUNITIVE, EXEMPLARY, SPECIAL OR CONSEQUENTIAL DAMAGES (INCLUDING, BUT NOT LIMITED TO, LOSS OF PROFIT OR COSTS OF SUBSTITUTE SERVICES) SUFFERED BY CUSTOMER, HOWEVER CAUSED, REGARDLESS OF THE THEORY OF LIABILITY, WHETHER IN CONTRACT, TORT, PRODUCT LIABILITY OR OTHERWISE, EVEN IF FINALSITE HAS BEEN PREVIOUSLY ADVISED OF THE POSSIBILITY, OR HAS CONSTRUCTIVE KNOWLEDGE, OF SUCH DAMAGES, AND NOTWITHSTANDING ANY FAILURE OF ESSENTIAL PURPOSE. EXCEPT AS EXPRESSLY SET FORTH IN THIS AGREEMENT, THIS AGREEMENT SHALL NOT CONVEY UPON ANY THIRD PARTY ANY RIGHTS HEREUNDER, AND NO THIRD PARTY SHALL BE DEEMED A THIRD PARTY BENEFICIARY.

17.9 Customer Procedures and Criteria. In the event the Services described in an Order include implementation of procedures or criterial specified by the Customer (such as the Customer's admission criteria and enrollment procedures), Finalsite expressly disclaims all liability associated with the content, and results obtained by use, of such procedures and criteria. The Customer is solely responsible for the scope if such procedures and criteria and reviewing the Services as configured by Finalsite to ensure compliance with the Customer's procedures and/or criteria. FINALSITE ASSUMES NO RESPONSIBILITY OR LIABILITY WITH RESPECT TO WHETHER THE CUSTOMER'S PROCEDURES OR CRITERIA COMPLY WITH APPLICABLE LAW OR REGULATORY REQUIREMENTS. TO THE EXTENT THAT CUSTOMER'S PROCEDURES OR CRITERIA VIOLATE ANY APPLICABLE LAWS OR REGULATORY REQUIREMENTS, FINALSITE RESERVES THE RIGHT TO REFUSE TO IMPLEMENT SUCH PROCEDURES OR CRITERIA WITHOUT LIABILITY HEREUNDER.

18. Affirmative Action, Equal Employment Opportunity

18.1 Non-Discrimination. Finalsite is committed to the policy that all persons shall have equal access to its programs, facilities, and employment without regard to race, color, creed, religion, sex, national origin, age,

marital status, disability, public assistance status, veteran status, or sexual orientation and are committed to follow these practices of non-discrimination, equal employment opportunity, and affirmative action. Finalsite shall use good faith efforts to ensure implementation of this policy in its employment practices, including recruitment, layoff or termination, rates of pay or other forms of compensation, and selection for training. Where required by applicable law, Finalsite has implemented written affirmative action plans.

19. Background Checks

19.1 Background Checks. If any Finalsite employees or agents shall have access to the Customer facilities, Student Data or other Confidential Information, Finalsite shall screen all such employees and agents, including interviews, reference checks, and credit history, as applicable to the scope of such access. Finalsite shall conduct criminal background checks in accordance with state and federal law for Finalsite employees and who may have direct contact with children under this Agreement. Background checks will be done prior to any contact with children, and shall be done in accordance with applicable state and federal laws.

20. Insurance.

20.1 Minimum Coverage Limits. At all times during the Term of this Agreement, Finalsite shall maintain the following minimum insurance coverages and shall provide a certificate of insurance evidencing such coverages to the Customer upon request.

(i) Commercial General Liability coverage in the amount of \$1,000,000 per occurrence and \$2,000,000 general aggregate;

(ii) automobile liability coverage in the amount of \$1,000,000 combined single limit;

(iii) umbrella liability coverage, occurrence based with limits of at least \$5,000,000 per occurrence and in the aggregate;

(iv) workers' compensation and employee liability coverage for statutory limits; and

(v) professional, data privacy and network security coverage with an aggregate limit of \$5,000,000.

21. Modifications/ Amendments.

This Agreement (including any Order and/or SOW) can only be modified or amended by a written agreement

signed by persons authorized to sign agreements on behalf of each of the Parties.

22. Waiver.

No failure to exercise and no delay in exercising on the part of either Party, or partial exercise, shall operate as a waiver of any right under this Agreement. A waiver on one occasion shall not operate as a waiver on other occasions.

23. Severability.

If any term or provision of this Agreement or application of the terms of this Agreement to the Parties shall to any extent be held invalid or unenforceable by a court of competent jurisdiction, then such invalidity will not affect the remainder of this Agreement and each other term and provision shall be valid and enforceable to the fullest extent permitted by law.

24. Relationship of Parties.

The Parties are independent contractors and will have no power or authority to assume or create any obligation or responsibility on behalf of each other. This Agreement will not be construed to create or imply any partnership, agency or joint venture, association, or other form of agency relationship between the Parties. A Party and its respective personnel shall not be eligible to participate in any employee welfare or other benefit plans, however characterized, which may be maintained by the other Party. Each Party agrees to assume all responsibility and liability for any and all federal and state employers' liability, workers' compensation, social security and unemployment insurance requirements with respect to its respective personnel. Each Party agrees to pay and report (or require to be paid and reported) all federal, state and local income, employment and payroll withholding taxes and other governmental taxes or charges for its respective personnel as may be applicable.

25. Assignment.

This Agreement may not be transferred or assigned directly or indirectly by either Party, in whole or in part, without the prior written consent of the other Party, which consent shall not be unreasonably withheld. Notwithstanding the foregoing, Finalsite may freely assign this Agreement to an affiliate and/or in connection with a change of control transaction or sale of substantially all of its business or assets as a going concern.

26. Force Majeure.

Either Party will be excused from delays in performing or from failing to perform its obligations under this Agreement (except for payment obligations which may be delayed but shall not be so excused) to the extent the

delays or failures result from causes beyond the reasonable control of the Party. Without limiting the generality of the foregoing, such causes include acts of God, the public enemy, fires, floods, storms, earthquakes, riots, terrorism, strikes, blackouts, wars or war operations, restraints of government, including public states of emergency, utility or communications failures, denial of service, hacking and other malicious attacks and activities, software viruses, telecommunications slow-downs or failure, erroneous data transmission, and causes which could not, with reasonable diligence, be controlled or prevented by the Party. However, to be excused from delay or failure to perform, the Party must promptly provide written notice to the other Party and act diligently to remedy the cause of the delay or failure.

27. Entire Agreement.

This Agreement, including any and all Orders, SOWs, Exhibits, Schedules, Attachments and material incorporated by reference, contains the entire agreement of the Parties relating to the rights granted and obligations assumed in this Agreement. This Agreement represents the complete and final agreement of the Parties and supersedes and replaces all prior or contemporaneous oral or written agreements, understandings or commitments between the Parties, including any purchase order. For clarity, while the Customer may utilize a purchase order for its internal administrative purposes, any terms or conditions in any such purchase order shall be deemed null and void and the terms and conditions of this Agreement shall solely govern and control.

28. Indemnification.

28.1 Finalsite Indemnity. Finalsite will indemnify and defend the Customer against any third-party claim and cause of action and any resulting loss, damage or expense (including reasonable attorney's fees) awarded against the Customer to the extent caused by (i) any fraud or willful misconduct by Finalsite or its Representatives; or (ii) the infringement by the SaaS Services, as provided by Finalsite and used in accordance with the terms of this Agreement and the relevant Order, of any Intellectual Property Rights of such third party. If any SaaS Services are held or believed to infringe any third party's Intellectual Property Rights, Finalsite may, in its sole discretion, (i) modify the relevant SaaS Services to be non-infringing, (ii) obtain for the Customer the right to continue using the relevant SaaS Services or (iii) if neither (i) nor (ii) are commercially practicable, terminate the relevant Order as to the alleged infringing SaaS Services and return to the Customer any unearned fees for use of such SaaS Services prepaid by the Customer to Finalsite.

28.2 Exclusions. The foregoing indemnity will not apply and Finalsite will not be liable for any damages assessed in any cause of action to the extent such cause of action arises or damages result from (i) the Customer's or its Authorized Users' use of the relevant SaaS Services other than as set forth in this Agreement and the relevant Order; or (ii) the combination, operation or use of the relevant SaaS Services with software, hardware, technology or other materials not approved or supplied by Finalsite, if infringement (including, without limitation, contributory infringement) would have been avoided by use of the relevant SaaS Services without such software, hardware, technology, or other materials.

28.3 Customer Indemnity. Except to the extent expressly prohibited by law with respect to immunity of government entities applicable to the Customer, the Customer shall indemnify and hold Finalsite, its licensor's and each such party's affiliates, officers, directors, employees, attorneys and agents harmless from and against any and all third party claims, costs, damages, losses, liabilities and expenses (including attorneys' fees and costs) awarded against Finalsite to the extent caused by: (i) any fraud willful misconduct of the Customer or its Representatives or Authorized Users; (ii) the infringement by the Customer Materials, and/or any Third Party Technology provided to Finalsite or input into the SaaS Services by the Customer or its Authorized Users, of the Intellectual Property Rights of a third party; and (iii) the nature, substance or content of the Customer Materials (such as a defamation claim, an invasion of privacy claim, a claim arising from lack of consent to use the Customer Materials).

28.4 Indemnity Procedure. The indemnities set forth in this Agreement are conditioned on the following: (i) the party claiming indemnification (the "Indemnitee") shall promptly notify the indemnifying party (the "Indemnitor") of any matters in respect of which it seeks to be indemnified, and shall give the Indemnitor full cooperation and opportunity to control the response thereto and the defense thereof, including without limitation any settlement thereof; (ii) the Indemnitor shall have no obligation for any claim under this Agreement if the Indemnitee makes any admission regarding such claim involving the Indemnitor without the prior written consent of the Indemnitor, which consent shall not be unreasonably withheld; and (iii) the Indemnitee's failure to promptly give notice to the Indemnitor shall affect the Indemnitor's obligation to indemnify the Indemnitee only to the extent the Indemnitor's rights are materially prejudiced by such failure. The Indemnitee may participate, at its own expense, in such defense and in any settlement discussions directly or through counsel of its choice. Each party will take reasonable steps to mitigate



any potential damages. If both the Indemnitor and Indemnitee are at fault, then the Indemnitor shall indemnify the Indemnitee only for the percentage of responsibility for the damage or injuries attributable to the Indemnitor.

28.5 Exclusive Remedy. THIS SECTION 28 STATES THE ENTIRE LIABILITY AND OBLIGATIONS OF EACH PARTY, AND THE EXCLUSIVE REMEDY OF EACH PARTY, WITH RESPECT TO CLAIMS BY ANY THIRD PARTY.

29. Venue and Applicable Law.

This Agreement shall be governed, construed, and interpreted in accordance with the laws of the jurisdiction of the Customer's formation, excluding conflict of law principles.

30. Export Control.

Customer shall not export or allow the export or re-export the Services, any components thereof or any Confidential Information of Finalsite without our express, prior, written consent and except in compliance with all export control laws and regulations of the U.S. Department of Commerce and all other U.S. agencies and authorities, and, if applicable, relevant foreign laws and regulations.

SERVICES RIDER – MASS NOTIFICATION SERVICES

The following additional terms and conditions shall apply to any Order in which the Customer purchases access to mass notification Services ("Mass Notification Services") and such terms and conditions are incorporated by reference and made a part of the Master Terms.

1. Definitions. For purposes of this Agreement, an "Emergency" is a serious and unexpected incident, situation, or natural phenomenon that may require action but is not immediately threatening to life, health, property or the environment or has a high probability of escalating to cause immediate danger to life, health, property or environment. An "Emergency Message" is a Message sent to all recipients in connection with an Emergency. An "Outreach Message" is a Message sent to one or more recipients for general outreach and informational purposes that is not an Emergency Message. The term "Excess Usage" means the amount of SMS texts, email messages, phone voice minutes, iOS/Android application notifications and other usage metrics initiated through the Mass Notification Services in excess of the usage limits described in the relevant Order and this Agreement. If no usage limits are described in the relevant Order, the relevant usage limits will be equal to 8 emails, 8 app notifications, 6 SMS text messages and 4 voicemail minutes per Student per month. "Student" means the number of full-time students enrolled at Customer's institution.

2. Customer Representations, Obligations, and Indemnity. Customer represents and warrants that: (i) it will comply with all applicable laws and contracts in connection with use of contact data for all message recipients ("Contact Data") and the Mass Notification Services, and with respect to the content and transmission of calls, texts, and other messages ("Messages") sent using the Mass Notification Services, including, without limitation, all federal and state telemarketing-related laws, rules and regulations, the Telephone Consumer Protection Act (47 U.S.C. § 227) the FCC's implementing regulations (47 C.F.R. § 64.1200) (such laws, rules and regulations, as amended from time-to-time, collectively, the "Telemarketing Laws"), and where applicable, the legislation commonly referred to as Canada's Anti-Spam Legislation (S.C. 2010, c. 23) ("CASL"); (ii) as to each recipient to be contacted by Finalsite on your behalf, you have obtained consents that may be required by the Telemarketing Laws, CASL and your

privacy policies; (iii) you will retain documentary proof of such consents for at least five (5) years from the date the recipient's contact information is provided by you to us; (iv) you will suppress and will not provide to us contact information for any recipient who has registered his or her telephone number on the national Do-Not-Call Registry, any similar state registries or has otherwise indicated that he or she does not wish to be contacted by you or us; (v) you will have in place reasonable safety and emergency response procedures in the event of an Emergency (including without limitation, notifying 911 or equivalent, fire, police, emergency medical, and public health, collectively, "First Responder Services") which do not utilize the Mass Notification Services; (vi) you will not take actions that will subject Finalsite to any liability under applicable law due to the import of Contact Data; (vii) you will provide a reasonable means for message recipients to rescind consent to receive Messages and will not send Messages to message recipients who have opted out of receiving Messages from you; and (viii) where you are providing a recipient and/or Student count or other data for the purposes of our Service pricing quotations, such information shall be true and correct. Customer will designate qualified personnel to act as liaisons between Customer and Finalsite with respect to technical, administrative and content matters, and providing accurate and current contact information. Finalsite shall have the right to require you to provide a legal compliance plan in connection with your use of our Mass Notification Services and may audit your compliance with such plan as well as compliance with the terms of this Product Rider. Failure to comply with any provision of this Section 2 is a material breach of the Agreement. Except to the extent prohibited by applicable law, including laws providing for the sovereign immunity of government entities, you agree to indemnify, defend and hold us harmless from and against all claims, lawsuits, proceedings, causes of action, damages, liabilities, losses, judgments, fines, penalties, costs, and expenses (including reasonable attorneys' fees) relating to or arising out of your breach of the foregoing representations,

warranties and obligations, or in connection with any claim or action from a third party that arises from the sending (or inability to send or receive), content, or effects of any Messages you distribute using, or your failure to use, the Mass Notification Service. In connection with such indemnity and defense obligations related to a third-party claim, lawsuit or proceeding: (i) Finalsite may participate in such defense through counsel of our own choosing, which participation shall be at our sole expense, and (ii) Customer shall not settle or permit the settlement of any such third-party claim, lawsuit, or proceeding without our prior written consent, which consent shall not be unreasonably withheld. This Section shall survive any termination of this Agreement for any reason.

3. Marketing and Political Activities. The Mass Notification Services shall not be used for marketing or political activities.

4. Excessive Usage. In the event of Excessive Usage of the Mass Notification Services, additional fees may apply, as described in the relevant Order. We shall use reasonable commercial efforts to notify you via notification through the Mass Notification Services, through our representatives and/or via email prior to assessing any such additional charges. Unless otherwise specified in the relevant Order, Finalsite reserves the right to charge for Excess Usage as it may occur throughout the Term, provided however, any failure by Finalsite to timely invoice for any overages shall not

constitute a waiver of your obligation to pay such fees for Excess Usage.

5. Remedies and Disclaimers. In the event of any failure of the Mass Notification Services to comply with the Agreement, your sole and exclusive remedy shall be to terminate the Mass Notification Services. You agree that the Mass Notification Services are not intended, nor designed, for use in high-risk activities or Emergency situations, or in any situation where failure of the Mass Notification Services could lead to death, personal injury, or damage to property, or where other damages could result if an error or outage occurred. The parties further acknowledge and agree that, NOTWITHSTANDING ANY PROVISION TO THE CONTRARY IN THIS AGREEMENT, TO THE EXTENT NOT PROHIBITED BY APPLICABLE LAW, FINALSITE SHALL NOT BE LIABLE FOR ANY DEATH, PERSONAL INJURY, OR DAMAGES ARISING OUT OF OR RELATED TO USE OF THE MASS NOTIFICATION SERVICES. You agree that your primary recourse in the event of any actual or potential threat to person or property should be to contact First Responder Services and that the Mass Notification Services are not intended to replace such First Responder Services, or to be used for communicating with, or replace notification to, or interoperate directly with, such First Responder Services, which should have already been notified and deployed prior to using the Mass Notification Services.

FINALSITE STUDENT DATA PRIVACY AGREEMENT¹

This Student Data Privacy Agreement (“**DPA**”) is entered into on the date of full execution of the Order and Statement of Work (“**Effective Date**”) and is entered into by and between the educational agency set forth below as identified in the signature block of this DPA (“**LEA**” or “**Customer**”) and ACTIVE INTERNET TECHNOLOGIES, LLC, a Connecticut Corporation, d/b/a Finalsity, with offices at 655 Winding Brook Drive, Glastonbury, Connecticut, 06033 (“**Finalsite**”) (jointly “**the Parties**”, and each a “**Party**”).

WHEREAS, Finalsite is providing digital services to LEA, as specified in certain contractual documents, including the applicable Master Terms and Conditions (“**Master Terms**”), each fully executed Order and Statement of Work, or under any services agreement or similar agreement (collectively, “**Agreement**”). Capitalized terms now otherwise defined in this DPA shall have the meanings ascribed to them in the Master Terms.

WHEREAS, Finalsite and LEA recognize the need to protect personally identifiable student information and other regulated data exchanged between them as required by applicable laws and regulations, such as the Family Educational Rights and Privacy Act (“**FERPA**”) at 20 U.S.C. § 1232g (34 CFR Part 99); the Children’s Online Privacy Protection Act (“**COPPA**”) at 15 U.S.C. § 6501-6506 (16 CFR Part 312), Protection of Pupil Rights Amendment (“**PPRA**”) 20 U.S.C. 1232h, applicable state privacy laws and regulations;

WHEREAS, Finalsite and LEA desire to enter into this DPA for the purpose of establishing their respective obligations and duties in order to comply with applicable data protection laws and regulations; and

WHEREAS, this DPA supplements the Agreement and in the event of any conflict between the terms of this DPA and the terms of the Agreement, the terms of this DPA prevail with regard to the specific subject matter of this DPA.

NOW THEREFORE, for good and valuable consideration, the receipt and sufficiency of which is hereby acknowledged, the Parties agree as follows:

1. Standard Clauses. A description of the Services to be provided, the categories of Student Data that may be provided by LEA to Finalsite, and other information specific to this DPA are contained in the Standard Clauses hereto.
2. Special Provisions. Supplemental State Terms and attached hereto as Exhibit F are hereby incorporated by reference into this DPA in their entirety.
3. Conflicts. In the event of a conflict between this DPA’s Standard Clauses and applicable Supplemental State Terms, the Supplemental State Terms will control. In the event there is conflict between the terms of the DPA and any other writing, including, but not limited to the Agreement and Finalsite Terms of Service or Privacy Policy, the terms of this DPA shall control. This DPA amends, supersedes and replaces any prior agreement relating to data processing and/or data protection the Parties entered into.
4. Term. This DPA shall stay in effect for the term of the Agreement.
5. Services. The services to be provided by Finalsite to LEA pursuant to this DPA are detailed in Exhibit A.

¹ Modeled after the Student Data Privacy Consortium’s set of National Data Processing Addendum for student data (Version 1.0).

6. Notices. All notices or other communication required or permitted to be given hereunder may be given via e-mail transmission, or first-class mail, sent to the designated representatives below.

The designated representative for LEA for this DPA is:

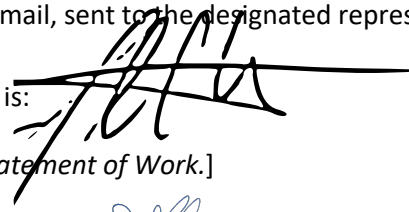

[Please see the signature page of the Order and Statement of Work.]

The designated representative for Finalsité for this DPA is:



[Please see the signature page of the Order and Statement of Work.]

IN WITNESS WHEREOF, LEA and Finalsité hereto agree, as evidenced by the signature page of the Order and Statement of Work to which this DPA is incorporated by reference, the Parties have executed this DPA as of the Effective Date.

1 STANDARD CLAUSES

ARTICLE 1 SCOPE AND PURPOSE

- 1.1 **Purpose of DPA.** The purpose of this DPA is to describe the Parties' duties and responsibilities related to Student Data, including compliance with Applicable Data Protection Laws. In performing the Services, for the purposes of FERPA, Finalsité shall be considered a School Official with a legitimate educational interest, and performing services otherwise provided by LEA. Finalsité shall be under the direct control and supervision of LEA with respect to its Processing of Student Data.
- 1.2 **Student Data to Be Provided.** In order to perform the Services described above, LEA shall provide Student Data as identified in the Schedule of Data, attached hereto as Exhibit B.
- 1.3 **DPA Definitions.** The definition of terms used in this DPA is found in Exhibit C. In the event of a conflict, definitions used in this DPA shall prevail over terms used in any other writing, including, but not limited to the Service Agreement, Terms of Service, Privacy Policies etc.

ARTICLE 2 DATA OWNERSHIP AND AUTHORIZED ACCESS

- 2.1 **Student Data Property of LEA.** As between LEA and Finalsité, all Student Data transmitted to Finalsité pursuant to the Agreement is and will continue to be the property of and under the control of LEA. Finalsité further acknowledges and agrees that all copies of such Student Data transmitted to Finalsité, including any modifications or additions or any portion thereof from any source, are subject to the provisions of this DPA in the same manner as the original Student Data. The Parties agree that as between them, all rights, including all intellectual property rights in and to Student Data contemplated per the Agreement, shall remain the exclusive property of LEA.
- 2.2 **Parent Access.** LEA shall establish reasonable procedures by which a parent, legal guardian, or eligible student may review Education Records and/or Student Data, correct erroneous information, and transfer student-generated content to a personal account, consistent with the functionality of services. Finalsité shall respond in a reasonably timely manner (and no later than forty-five (45) days from the date of the request or pursuant to the time frame required under state law for an LEA to respond to a parent or student, whichever is sooner) to LEA's request for Student Data in a student's records held by Finalsité to view or correct as necessary. In the event that a parent of a student or other individual contacts Finalsité to review any of the Student Data accessed pursuant to the Services, Finalsité shall refer the parent or individual to LEA, who will follow the necessary and proper procedures regarding the requested information, provided however, that Finalsité may also allow for direct access requests (but not correction or deletion rights) of Student Data and/or Education Records from a verified parent or guardian through tools available through Finalsité Services that permits users to access and/or manage their records.
- 2.3 **Separate Account.** To the extent applicable, if Student Generated Content is Processed by Finalsité as part of the Services, Finalsité may, at the request of LEA, transfer, or provide a mechanism for LEA to transfer, said Student Generated Content to a separate account created by the student.
- 2.4 **Third Party Requests.** Should a third party, including law enforcement or other government entities ("Requesting Party(ies)") contact Finalsité with a request for Student Data held by Finalsité pursuant to the Services, Finalsité shall redirect the Requesting Party to request Student Data directly from LEA and shall not provide the requested Student Data to the Requesting Party, unless

to the extent that Finalsité reasonably believes it is compelled to grant such access to the third party because the data disclosure is necessary: (i) pursuant to a court order or legal process, (ii) to comply with Applicable Data Protection Laws, (iii) to enforce the Agreement, or (iv) to protect the rights, property or personal safety of Finalsité’s users, employees or others, or the security of the Services. Finalsité shall notify LEA in advance of a compelled disclosure to the Requesting Party, unless lawfully directed by the Requesting Party not to inform LEA of the request.

- 2.5 **Subprocessors.** Finalsité shall enter into written agreements with all Subprocessors performing functions for Finalsité in order for Finalsité to provide the Services pursuant to the Agreement. LEA acknowledges and agrees that (a) Finalsité’s Affiliates may be retained as Subprocessors, (b) Finalsité may engage its current Subprocessors listed in the customer portal on its website, as published by Finalsité and may be updated from time to time at <https://www.finalsite.com/subprocessors>; and (c) Finalsité and Finalsité’s Affiliates respectively may engage third-party Subprocessors in connection with the provision of the Services.

ARTICLE 3 DUTIES OF LEA

- 3.1 **Provide Data in Compliance with Applicable Laws.** LEA warrants that it shall, in its use of and for the purposes of obtaining the Services, Process Student Data and provide Student Data in compliance with Applicable Data Protection Laws, as may be amended from time to time.
- 3.2 **Annual Notification of Rights.** If LEA has a policy of disclosing Education Records and/or Student Data under FERPA (34 CFR § 99.31(a)(1)), LEA shall include a specification of criteria for determining who constitutes a school official and what constitutes a legitimate educational interest in its annual notification of rights. Additionally, LEA represents, warrants, and covenants to Finalsité, as applicable, that LEA has (a) complied with the School Official Exemption, including, without limitation, informing parents in their Annual Notification of Rights that LEA defines “school official” to including service providers such as Finalsité and defines “legitimate educational interest” to include services such as the Services provided by Finalsité; (b) complied with the Directory Information Exemption, including, without limitation, informing parents and eligible students what information LEA deems to be Directory Information and may be disclosed and allowing parents and eligible students a reasonable amount of time to request that schools not disclose Directory Information about them; and (c) obtained all necessary parental, legal guardians’, or eligible student written consent to share the Student Data with Finalsité, in each case, solely to enable Finalsité’s operation of the Services.
- 3.3 **Reasonable Precautions.** LEA shall use reasonable administrative, physical and technical safeguards designed to secure usernames, passwords, and any other means of gaining access to the Services and hosted Student Data from unauthorized access, disclosure or acquisition by an unauthorized person.
- 3.4 **Unauthorized Access Notification.** LEA shall notify Finalsité promptly, within 72 hours, of any known or suspected unauthorized use or access of the Services. LEA will assist Finalsité in any efforts by Finalsité to investigate and respond to any unauthorized use or access.

ARTICLE 4 DUTIES OF FINALSITE

- 4.1 **Privacy Compliance.** Finalsité shall comply with all applicable federal, state, and local laws, rules, and regulations pertaining to Student Data privacy and security, all as may be amended from time to time.
- 4.2 **Authorized Use.** The Student Data shared pursuant to the Agreement, including persistent unique identifiers, shall be used for no purpose other than the Services outlined in Exhibit A or stated in the Agreement and/or otherwise authorized under the statutes referred to herein this DPA.
- 4.3 **Finalsite Employee Obligation.** Finalsité shall require all of Finalsité's employees and agents who have access to Student Data to comply with all applicable provisions of this DPA with respect to the Student Data shared under the Agreement. Finalsité agrees to require each employee or agent with access to Student Data to adhere to their confidentiality obligations with regard to Student Data.
- 4.4 **No Disclosure.** Finalsité acknowledges and agrees that it shall not make any re-disclosure of any Student Data or any portion thereof, including without limitation, user content or other non-public information and/or Personally Identifiable Information contained in the Student Data other than as directed or permitted by LEA or this DPA. This prohibition against disclosure shall not apply to (a) aggregate summaries of De-Identified Data, (b) Student Data disclosed pursuant to a lawfully issued subpoena or other legal process, (c) to Subprocessors performing services on behalf of Finalsité pursuant to this DPA, (d) to authorized users of the Services, including parents or legal guardians, or (f) to protect the rights, property or personal safety of Finalsité's users, employees or others, or the security of the Services.
- 4.5 **De-Identified Data.** Finalsité agrees not to attempt to re-identify De-Identified Data. De-Identified Data may be used by Finalsité for those purposes allowed under FERPA and the following purposes: (a) assisting LEA or other governmental agencies in conducting research and other studies; and (b) research and development of Finalsité's educational sites, services, or applications, and to demonstrate the effectiveness of the Services; and (c) for adaptive learning purposes and for customized student learning. Finalsité's use of De-Identified Data shall survive termination of this DPA or any request by LEA to return or destroy Student Data. Except for Subprocessors, Finalsité agrees not to transfer De-Identified Data to any party unless (i) that party agrees in writing not to attempt re-identification, and (ii) prior written notice has been given to LEA who has provided prior written consent for such transfer. Prior to publishing any document that names LEA explicitly or indirectly, Finalsité shall obtain LEA's written approval of the manner in which De-Identified Data is presented.
- 4.6 **Disposition of Data.** Upon written request from LEA, Finalsité shall dispose of or provide a mechanism for LEA to transfer Student Data obtained under the Agreement, within sixty (60) days of the date of said request and according to a schedule and procedure as the Parties may reasonably agree. Upon termination of this DPA, if no written request from LEA is received, Finalsité shall dispose of all Student Data after providing LEA with reasonable prior notice. The duty to dispose of Student Data shall not extend to Student Data that had been De-Identified or placed in a separate student account pursuant to Section 3.3. LEA may employ a "**Directive for Disposition of Data**" form, a copy of which is attached hereto as Exhibit D. If LEA and Finalsité employ Exhibit D, no further written request or notice is required on the part of either party prior to the disposition of Student Data described in Exhibit D.

- 4.7 **Advertising Limitations.** Finalsité is prohibited from using, disclosing, or selling Student Data to: (a) inform, influence, or enable Targeted Advertising; or (b) develop a profile of a student, family member/guardian or group, for any purpose other than providing the Service to LEA. This section does not prohibit Finalsité from using Student Data (i) for adaptive learning or customized student learning (including generating personalized learning recommendations); or (ii) to make product recommendations to teachers or LEA employees; or (iii) to notify account holders about new education product updates, features, or services or from otherwise using Student Data as permitted in this DPA and its accompanying exhibits.

ARTICLE 5 DATA PROVISIONS

- 5.1 **Data Storage.** Where required by applicable law, Student Data shall be stored within the United States. Upon request of LEA, Finalsité will provide a list of the locations where Student Data is stored.
- 5.2 **Audits.** No more than once a year, or following a Security Incident, upon receipt of a written request from LEA with at least ten (10) business days' notice and upon the execution of an appropriate confidentiality agreement, at the cost of LEA, Finalsité will allow LEA's third party auditor to audit, during normal business hours and at a time convenient for Finalsité, the security and privacy measures that are in place to ensure protection of Student Data or any portion thereof as it pertains to the delivery of services to LEA ("**Security Audit**"). Finalsité will cooperate reasonably with LEA and any local, state, or federal agency with oversight authority or jurisdiction in connection with any audit or investigation of Finalsité and/or delivery of Services to students and/or LEA, and shall provide reasonable access to Finalsité's facilities, staff, agents and LEA's Student Data and all records pertaining to Finalsité, LEA and delivery of Services to LEA, as reasonably necessary to fulfill such Security Audit requests. Failure to reasonably cooperate shall be deemed a material breach of the DPA. Finalsité may provide an independent third-party report or certification in place of allowing LEA to conduct such Security Audit.
- 5.3 **Data Security.** Finalsité agrees to utilize administrative, physical, and technical safeguards designed to protect Student Data from unauthorized access, disclosure, acquisition, destruction, use, or modification. Finalsité shall adhere to any applicable law relating to data security. Finalsité shall implement an adequate Cybersecurity Framework based on one of the nationally recognized standards set forth in Exhibit E. Additionally, Finalsité may choose to further detail its security programs and measures that augment or are in addition to the Cybersecurity Framework in Exhibit E. Finalsité shall provide, in Exhibit E to the DPA, contact information of an employee who LEA may contact if there are any data security concerns or questions.
- 5.4 **Data Breach.** To the extent required under Applicable Data Protection Laws, in the event that Finalsité becomes aware of an unauthorized release, disclosure or acquisition of Student Data that compromises the security, confidentiality, availability, or integrity of the Student Data maintained by Finalsité in violation of Applicable Data Protection Laws ("**Security Incident**"), Finalsité shall provide notification to LEA, to the extent required under Applicable Data Protection Laws, but in no event later than seventy-two (72) hours of confirmation of the Security Incident ("**Security Incident Notification**"), unless notification within this time limit would disrupt investigation of the Security Incident by law enforcement or by Finalsité. In such an event, notification shall be made within a reasonable time after the discovery of the Security Incident. Finalsité's obligation to report or respond to a Security Incident under this Section is not and will not be construed as an

acknowledgement by Finalsight of any fault or liability with respect to the Security Incident. Finalsight shall follow the following process:

- 5.4.1 Unless otherwise required by Applicable Data Protection Laws, the Security Incident Notification described above shall include, at a minimum, the following information to the extent known by Finalsight and as it becomes available:
 - 5.4.1.1 The name and contact information of the reporting LEA subject to this section.
 - 5.4.1.2 A list of the types of Student Data that were or are reasonably believed to have been the subject of a breach.
 - 5.4.1.3 If the information is possible to determine at the time the notice is provided, then either (1) the date of the Security Incident, (2) the estimated date of the Security Incident, or (3) the date range within which the Security Incident occurred. The notification shall also include the date of the notice.
 - 5.4.1.4 Whether the notification was delayed as a result of a law enforcement investigation, if that information is possible to determine at the time the notice is provided; and
 - 5.4.1.5 A general description of the Security Incident, if that information is possible to determine at the time the notice is provided.
- 5.4.2 Finalsight agrees to adhere to all federal and state requirements with respect to a Security Incident related to the Student Data, including, when appropriate or required, the required responsibilities and procedures for notification and mitigation of any such Security Incident.
- 5.4.3 Finalsight further acknowledges and agrees to have a written incident response plan that reflects best practices and is consistent with industry standards and federal and state law for responding to a Security Incident involving Student Data or any portion thereof, including Personally Identifiable Information and agrees to provide LEA, upon request, with a summary of said written incident response plan.
- 5.4.4 To the extent that third party notice requirements under Applicable Data Protection Laws are triggered by the Security Incident, LEA shall provide notice on the facts surrounding the Security Incident to the affected students, parents or guardians. Finalsight will cooperate with LEA as to the timing and content of the notice.
- 5.4.5 In the event of a Security Incident originating from LEA's use of the Service, or otherwise a result of LEA's actions or inactions, Finalsight shall cooperate with LEA to the extent necessary to expeditiously secure Student Data, at LEA's cost.

ARTICLE 6 LIMITATION OF LIABILITY

- 6.1 **Limitation of Liability.** Each Party's and all of its Affiliates' liability, taken together in the aggregate, arising out of or related to this DPA, and all DPAs between Authorized Affiliates and Finalsight, whether in contract, tort or under any other theory of liability, is subject to the 'Liability Limitation' section of the Agreement, and any reference in such section to the liability of a Party means the aggregate liability of that Party and all of its Affiliates under the Agreement and all DPAs together.

ARTICLE 7 MISCELLANEOUS

- 7.1 **Supplement State Terms.** To the extent Finalsité enters into the Agreement with an LEA located in one of the States identified within Exhibit F (Supplement State Terms) of this DPA, the terms specified in Exhibit F with respect to the applicable state apply in addition to the terms of this DPA. In the event of a conflict between this DPA's Standard Clauses and applicable Supplemental State Terms, the Supplemental State Terms will control.
- 7.2 **Termination.** In the event that either Party seeks to terminate this DPA, it may do so by mutual written consent so long as the Agreement has lapsed or has been terminated. Either party may terminate this DPA and any Agreement or contract if the other party breaches any terms of this DPA.
- 7.3 **Effect of Termination Survival.** If the Agreement is terminated, Finalsité shall destroy all of Student Data pursuant to Section 4.6.
- 7.4 **Entire Agreement.** This DPA and the Agreement constitute the entire agreement of the Parties relating to the subject matter hereof and supersedes all prior communications, representations, or agreements, oral or written, by the Parties relating thereto. This DPA may be amended and the observance of any provision of this DPA may be waived (either generally or in any particular instance and either retroactively or prospectively) only with the signed written consent of both Parties. Neither failure nor delay on the part of any Party in exercising any right, power, or privilege hereunder shall operate as a waiver of such right, nor shall any single or partial exercise of any such right, power, or privilege preclude any further exercise thereof or the exercise of any other right, power, or privilege.
- 7.5 **Severability.** Any provision of this DPA that is prohibited or unenforceable in any jurisdiction shall, as to such jurisdiction, be ineffective to the extent of such prohibition or unenforceability without invalidating the remaining provisions of this DPA, and any such prohibition or unenforceability in any jurisdiction shall not invalidate or render unenforceable such provision in any other jurisdiction. Notwithstanding the foregoing, if such provision could be more narrowly drawn so as not to be prohibited or unenforceable in such jurisdiction while, at the same time, maintaining the intent of the Parties, it shall, as to such jurisdiction, be so narrowly drawn without invalidating the remaining provisions of this DPA or affecting the validity or enforceability of such provision in any other jurisdiction.
- 7.6 **Governing Law; Venue and Jurisdiction.** THIS DPA WILL BE GOVERNED BY AND CONSTRUED IN ACCORDANCE WITH THE LAWS OF THE STATE OF LEA, WITHOUT REGARD TO CONFLICTS OF LAW PRINCIPLES. EACH PARTY CONSENTS AND SUBMITS TO THE SOLE AND EXCLUSIVE JURISDICTION TO THE STATE AND FEDERAL COURTS FOR THE COUNTY OF LEA FOR ANY DISPUTE ARISING OUT OF OR RELATING TO THIS DPA OR THE TRANSACTIONS CONTEMPLATED HEREBY.
- 7.7 **Successors Bound.** This DPA is and shall be binding upon the respective successors in interest to Finalsité in the event of a merger, acquisition, consolidation or other business reorganization or sale of all or substantially all of the assets of such business. In the event that Finalsité sells, merges, or otherwise disposes of its business to a successor during the term of this DPA ("**Change of Control**"), Finalsité shall provide notice to LEA promptly after the closing date of such Change of Control. Such notice shall include assurances that the successor will assume the obligations of the DPA and any obligations with respect to Student Data within the Agreement.

- 7.8 **Authority**. Each Party represents that it is authorized to bind to the terms of this DPA, including confidentiality and destruction of Student Data and any portion thereof contained therein, all related or associated institutions, individuals, employees or contractors who may have access to the Student Data and/or any portion thereof.
- 7.9 **Waiver**. No delay or omission by either party to exercise any right hereunder shall be construed as a waiver of any such right and both Parties reserve the right to exercise any such right from time to time, as often as may be deemed expedient.
- 7.10 **Electronic Signature**. The Parties understand and agree that they have the right to execute this DPA through paper or through electronic signature technology, which is in compliance with applicable state and federal law governing electronic signatures. The Parties agree that to the extent they sign electronically, their electronic signature is the legally binding equivalent to their handwritten signature. Where they execute an electronic signature, it has the same validity and meaning as their handwritten signature. They will not, at any time in the future, repudiate the meaning of their electronic signature or claim that their electronic signature is not legally binding. They agree not to object to the admissibility of this DPA as an electronic record, or a paper copy of an electronic document, or a paper copy of a document bearing an electronic signature, on the grounds that it is an electronic record or electronic signature or that it is not in its original form or is not an original.

EXHIBIT A – DESCRIPTION OF SERVICES

Finalsite provides the following services through its platform or through consultancy (“**Services**”):

Details of the Services are listed in the Order and Statement of Work to which this DPA is incorporated by reference.

EXHIBIT B – SCHEDULE OF DATA

<u>Category of Data</u>	<u>Element</u>	<u>Check if used</u>
Application Technology Meta Data	IP Addresses of users, Use of Cookies, etc.	✓
	Other application technology meta data- Please specify:	
Application Use Statistics	Meta Data on user interaction with application	✓
Assessment	Standardized test Scores	
	Observation Data	
	Other assessment data-Please specify:	
Attendance	Student School (daily) attendance data	
	Student class attendance data	
Communications	Online Communications that are captured (emails, blog entries)	✓
Conduct	Conduct or behavioral data	
Demographics	Date of Birth	
	Place of Birth	
	Gender	
	Ethnicity or race	
	Language information (native, or primary language spoken by student)	

	Other demographic information- Please specify:	
Enrollment	Student School Enrollment	
	Student grade level	
	Homeroom	
	Guidance counselor	
	Specific curriculum programs	
	Year of graduation	
	Other enrollment information - Please specify:	
Parent/Guardian Contact information	Address	✓
	Email	✓
	Phone	✓
	Parent ID number (created to link parents to students)	✓
	First and/or Last	✓
Schedule	Student scheduled courses	
	Teacher names	
Special indicator	English Language Learner information	
	Low income status	

	Medical alerts/health data	
	Student disability information	
	Specialized education services (IEP or 504)	
	Living situations (Homeless/foster care)	
	Other indicator information-Please specify:	
Student Contact information	Address	
	Email	
	Phone	
Student Identifiers	Local (school district) ID number	
	State ID number	
	Finalsite/App assigned student ID number	
	Student app username	
	Student app password	
Student Name	First and/or Last	
Student in App Performance	Program/application performance (typing program-student types 60 wpm, reading program-student	

	reads below grade level)	
Student program membership	Academic or extracurricular activities a student may belong to or participate in	
Student survey responses	Responses to surveys or questionnaires	
Student Work	Student generated content; writing, pictures, etc.	
	Other student work data -Please specify:	
Transcript	Student course grades	
	Student course data	
	Student course grades/ performance scores	
	Other transcript data-Please specify:	
Transportation	Student bus assignment	
	Student pick up and/or drop off location	
	Student bus card ID number	
	Other transportation data-Please specify:	
Other	Please list each additional data element used, stored, or collected by your application:	
None	No Student Data collected at this time. Finalsite will immediately notify	

	LEA if this designation is no longer applicable.	
--	--	--

EXHIBIT C – DEFINITIONS

1.1 In this DPA, the following terms shall have the meanings set out below and cognate terms shall be construed accordingly:

7.11 **“Affiliate”** means any entity that directly or indirectly controls, is controlled by, or is under common control with the subject entity. “Control,” for purposes of this definition, means direct or indirect ownership or control of more than 50% of the voting interests of the subject entity.

7.12 **“Applicable Data Protection Laws”** means United States federal and state privacy laws and regulations applicable to the Processing of Student Data pursuant to the Agreement, including the Family Educational Rights and Privacy Act (“FERPA”) at 20 U.S.C. § 1232g (34 CFR Part 99); the Children’s Online Privacy Protection Act (“COPPA”) at 15 U.S.C. § 6501-6506 (16 CFR Part 312), Protection of Pupil Rights Amendment (“PPRA”) 20 U.S.C. 1232h.

7.13 **“Authorized Affiliate”** means an entity that (1) owns or controls, is owned or controlled by or is or under common control or ownership with LEA, where control is defined as the possession, directly or indirectly, of the power to direct or cause the direction of the management and policies of an entity, whether through ownership of voting securities, by contract or otherwise, and (2) is permitted to use the Services provided by Finalsight pursuant to the Agreement between LEA and Finalsight.

7.14 **“De-Identified Data”** and **“De-Identification”** means records and information when all personally identifiable information has been removed or obscured, such that the remaining information does not reasonably identify a specific individual, including, any information that, alone or in combination is linkable to a specific student and provided that the educational agency, or other party, has made a reasonable determination that a student’s identity is not personally identifiable, taking into account reasonable available information.

7.15 **“Educational Records”** means records, files, documents, and other materials directly related to a student and maintained by LEA and its Authorized Affiliates, including, records encompassing all the material kept in the student’s cumulative folder, such as general identifying data, records of attendance and of academic work completed, records of achievement, and result of evaluative tests, health data, disciplinary status, test protocols and individualized education programs.

7.16 **“LEA”** means the local educational agency, together with its Authorized Affiliates, that executed the Agreement, which determines the purposes and means of the Processing of Student Data. For the sake of clarity, references to LEA in this DPA concerns “Customer” as that term is defined under the Agreement.

7.17 **“Metadata”** means information that provides meaning and context to other data being collected; including, but not limited to: date and time records and purpose of creation. Metadata that has been stripped of all direct and indirect identifiers are not considered Personally Identifiable Information.

7.18 **“Operator”** means the operator of an internet website, online service, online application, or mobile application with actual knowledge that the site, service, or application is used for K–12 school purposes. Any entity that operates an internet website, online service, online application, or mobile application that has entered into a signed, written agreement with an LEA to provide a service to that LEA shall be considered an “Operator” for the purposes of this section.

7.19 **“Personal Identifiable Information”**, **“Personal Information”** or **“PII”** means any information relating to an identified or identifiable natural person, that relates to, describes, is reasonably capable of being associated with, or could reasonably be linked, directly or indirectly, with a particular natural person.

7.20 **“Processing”** means any operation or set of operations which is performed upon Personal Information, whether or not by automatic means, such as collection, recording, organization, structuring, storage, adaptation or alteration, retrieval, consultation, use, disclosure by transmission, dissemination or otherwise making available, alignment or combination, restriction, erasure or destruction.

7.21 **“School Official”** means a contractor that: (1) Performs an institutional service or function for which the agency or institution would otherwise use employees; (2) Is under the direct control of the agency or institution with respect to the use and maintenance of Student Data including Education Records; and (3) Is subject to 34 CFR § 99.33(a) governing the use and redisclosure of Personally Identifiable Information from Education Records.

7.22 **“Services”** means the provision of maintenance and support services, consultancy or professional services and the provision of software as a service or any other services provided under the Agreement where Finalsite Processes Student Data.

7.23 **“Student Generated Content”** means materials or content created by a student in the services including, but not limited to, essays, research reports, portfolios, creative writing, music or other audio files, photographs, videos, and account information that enables ongoing ownership of student content.

7.24 **“Student Data”** includes any data, whether gathered by Finalsite or provided by LEA or its users, students, students’ parents/guardians, prospective students, and prospective students’ parents/guardians that is descriptive of the student including, but not limited to, information in the student’s educational record or email, first and last name, birthdate, home or other physical address, telephone number, email address, or other information allowing physical or online contact, discipline records, videos, test results, special education data, juvenile dependency records, grades, evaluations, criminal records, medical records, health records, social security numbers, biometric information, disabilities, socioeconomic information, individual purchasing behavior or preferences, food purchases, political affiliations, religious information, text messages, documents, student identifiers, search activity, photos, voice recordings, geolocation information, parents’ names, or any other information or identification number that would provide information about a specific student. Student Data includes “Metadata.” Student Data further includes “Personally Identifiable Information (PII),” as defined in 34 C.F.R. § 99.3 and as defined under any applicable state law. Student Data shall constitute Education Records for the purposes of this DPA, and for the purposes of federal, state, and local laws and regulations. Student Data shall not constitute that information that has been anonymized or De-Identified, or anonymous usage data regarding a student’s use of Finalsite’s services.

7.25 **“Subprocessor”** means any data processor (including any third party and any Finalsite Affiliate, but excluding an employee of Finalsite or any of its sub-contractors) appointed by or on behalf of Finalsite or any Finalsite Affiliate to Process Personal Data on behalf of LEA or Authorized Affiliates in connection with the Agreement.

7.26 **“Targeted Advertising”** means presenting an advertisement to a student where the selection of the advertisement is based on Student Data or inferred over time from the usage of the Operator’s Internet website, online service or mobile application by such student or the retention of such student’s

online activities or requests over time for the purpose of targeting subsequent advertisements. Targeted Advertising does not include any advertising to a student on an Internet website based on the content of the webpage or in response to a student's response or request for information or feedback.

7.27 The word “**include**” shall be construed to mean include without limitation, and cognate terms shall be construed accordingly.

EXHIBIT D – DIRECTIVE FOR DISPOSITION OF DATA

LEA directs Finalsite to dispose of Student Data obtained by Finalsite pursuant to the terms of the DPA between LEA and Finalsite. The terms of the Disposition are set forth below:

1. Extent of Disposition

Disposition is partial. The categories of data to be disposed of are set forth below or are found in an attachment to this Directive:

[Insert categories of data here]

Disposition is Complete. Disposition extends to all categories of data.

2. Nature of Disposition

Disposition shall be by destruction or deletion of data.

Disposition shall be by a transfer of data. The data shall be transferred to the following site as follows:

[Insert or attach special instructions]

3. Schedule of Disposition

Data shall be disposed of by the following date:

As soon as commercially practicable.

By [Insert Date]

4. Signature

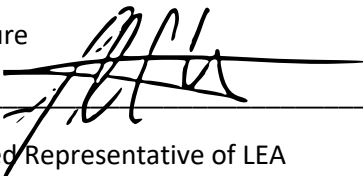
 _____ 4/5/2023
Authorized Representative of LEA Date

5. Verification of Disposition of Data







 _____ Apr 10, 2023
Authorized Representative of Finalsite Date

EXHIBIT E – DATA SECURITY REQUIREMENTS

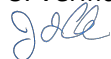
Adequate Cybersecurity Frameworks

The Education Security and Privacy Exchange (“Edspex”) works in partnership with the Student Data Privacy Consortium and industry leaders to maintain a list of known and credible cybersecurity frameworks which can protect digital learning ecosystems chosen based on a set of guiding cybersecurity principles* (“Cybersecurity Frameworks”) that may be utilized by Finalsite.

Cybersecurity Frameworks

	MAINTAINING ORGANIZATION/GROUP	FRAMEWORK(S)
	National Institute of Standards and Technology	NIST Cybersecurity Framework Version 1.1
	National Institute of Standards and Technology	NIST SP 800-53, Cybersecurity Framework for Improving Critical Infrastructure Cybersecurity (CSF), Special Publication 800-171
	International Standards Organization	Information technology — Security techniques — Information security management systems (ISO 27000 series)
	Secure Controls Framework Council, LLC	Security Controls Framework (SCF)
	Center for Internet Security	CIS Critical Security Controls (CSC, CIS Top 20)
	Office of the Under Secretary of Defense for Acquisition and Sustainment (OUSD(A&S))	Cybersecurity Maturity Model Certification (CMMC, ~FAR/DFAR)

Security Coordinator. The name and contact information of each Party’s designated representative for the purposes of matters relating to the security of Student Data received pursuant to the Agreement is set forth below:

1. Finalsite: Please contact our Security Committee at privacy@finalsite.com for any matters relating to the security of Student Data.
2. LEA’s designated representative for matters relating to the security of Student Data is set forth on the signature page of the Order and Statement of Work.

EXHIBIT F – SUPPLEMENT STATE TERMS (CALIFORNIA)

1. The definition of “**Applicable Data Protection Law**” includes Student Online Personal Information Protection Act (“**SOPIPA**”) at California Bus. & Prof. Code § 22584, and California Assembly Bill 1584 (“**AB 1584**”) at California Education Code § 49073.1.

2. To the extent that LEA is subject to the California Consumer Privacy Act of 2018 (CCPA) and/or the California Privacy Rights Act of 2020 (CPRA), “**Student Data**” includes any information relating to an identified or identifiable natural person that relates to, describes, is reasonably capable of being associated with, or could reasonably be linked, directly or indirectly, with a particular natural person.

3. **Modification to Section 5.7 of the DPA.** Section 5.7 of the DPA (Advertising Limitations) is amended by deleting the stricken text as follows:

Finalsite is prohibited from using, disclosing, or selling Student Data to (a) inform, influence, or enable Targeted Advertising; or (b) develop a profile of a student, family member/guardian or group, for any purpose other than providing the Service to LEA. This section does not prohibit Finalsite from using Student Data (i) for adaptive learning or customized student learning (including generating personalized learning recommendations); ~~or (ii) to make product recommendations to teachers or LEA employees; or (iii) to notify account holders about new education product updates, features, or services~~ or from otherwise using Student Data as permitted in this DPA and its accompanying exhibits.

EXHIBIT F– SUPPLEMENT STATE TERMS (ILLINOIS)

- 1. Compliance with Illinois Privacy Laws.** In performing its obligations under the Agreement, Finalsité shall comply with all Illinois laws and regulations pertaining to student data privacy, confidentiality, and maintenance, including but not limited to the Illinois School Student Records Act (“ISSRA”), 105 ILCS 10/, Mental Health and Developmental Disabilities Confidentiality Act (“MHDDCA”), 740 ILCS 110/, Student Online Personal Protection Act (“SOPPA”), 105 ILCS 85/, Identity Protection Act (“IPA”), 5 ILCS 179/, and Personal Information Protection Act (“PIPA”), 815 ILCS 530/, and Local Records Act (“LRA”), 50 ILCS 205/.
- 2. Definition of “Student Data.”** In addition to the definition set forth in **Exhibit C**, Student Data includes any and all information concerning a student by which a student may be individually identified under applicable Illinois law and regulations, including but not limited to (a) “covered information,” as defined in Section 5 of SOPPA (105 ILCS 85/5), (b) “school student records” as that term is defined in Section 2 of ISSRA (105 ILCS 10/2(d)) (c) “records” as that term is defined under Section 110/2 of the MHDDCA (740 ILCS 110/2), and (d) “personal information” as defined in Section 530/5 of PIPA.
- 3. School Official Designation.** Pursuant to Article 1, Section 1.1 of the DPA, and in accordance with FERPA, ISSRA and SOPPA, in performing its obligations under the DPA, Finalsité is acting as a school official with legitimate educational interest; is performing an institutional service or function for which LEA would otherwise use its own employees; is under the direct control of LEA with respect to the use and maintenance of Student Data; and is using Student Data only for an authorized purpose and in furtherance of such legitimate educational interest.
- 4. Limitations on Re-Disclosure.** Finalsité shall not re-disclose Student Data to any other party or affiliate without the express written permission of LEA or pursuant to court order, unless such disclosure is otherwise permitted under SOPPA, ISSRA, FERPA, and MHDDCA. Finalsité will not sell or rent Student Data. In the event another party, including law enforcement or a government entity, contacts Finalsité with a request or subpoena for Student Data in the possession of Finalsité, Finalsité shall redirect the other party to seek the data directly from LEA. In the event Finalsité is compelled to produce Student Data to another party in compliance with a court order, Finalsité shall notify LEA at least five (5) school days in advance of the court ordered disclosure and, upon request, provide LEA with a copy of the court order requiring such disclosure.
- 5. Notices.** Any notice delivered pursuant to the DPA shall be deemed effective, as applicable, upon receipt as evidenced by the date of transmission indicated on the transmission material, if by email; or four (4) days after mailing, if by first-class mail, postage prepaid.
- 6. Parent Right to Access and Challenge Student Data.** LEA shall establish reasonable procedures pursuant to which a parent, as that term is defined in 105 ILCS 10/2(g), may inspect and/or copy Student Data and/or challenge the accuracy, relevance or propriety of Student Data, pursuant to Sections 5 and 7 of ISSRA (105 ILCS 10/5; 105 ILCS 10/7) and Section 33 of SOPPA (105 ILCS 85/33). Finalsité shall respond to any request by LEA for Student Data in the possession of Finalsité when Finalsité’s cooperation is required to afford a parent an opportunity to inspect and/or copy the Student Data, no later than 5 business days from the date of the request. In the event that a parent contacts Finalsité directly to inspect and/or copy Student Data, Finalsité shall refer the parent to LEA, which shall follow the necessary and proper procedures regarding the requested Student Data.
- 7. Corrections to Factual Inaccuracies.** In the event that LEA determines that Finalsité is maintaining

Student Data that contains a factual inaccuracy, and Finalsité's cooperation is required in order to make a correction, LEA shall notify Finalsité of the factual inaccuracy and the correction to be made. No later than 90 calendar days after receiving the notice of the factual inaccuracy, Finalsité shall correct the factual inaccuracy and shall provide written confirmation of the correction to LEA.

8. **Security Standards.** Finalsité shall implement and maintain commercially reasonable security procedures and practices that otherwise meet or exceed industry standards designed to protect Student Data from unauthorized access, destruction, use, modification, or disclosure, including but not limited to the Security Incident. For purposes of the DPA and this Exhibit G, "Security Incident" does not include the good faith acquisition of Student Data by an employee or agent of Finalsité or LEA for a legitimate educational or administrative purpose of Finalsité or LEA, so long as the Student Data is used solely for purposes permitted by SOPPA and other applicable law, and so long as the Student Data is restricted from further unauthorized disclosure.
9. **Security Incident Notification.** In addition to the information enumerated in Article 5, Section 5.4.1 of the DPA Standard Clauses, any Security Incident Notification provided by Finalsité to LEA shall include:
 - a. A list of the students whose Student Data was involved in or is reasonably believed to have been involved in the breach, if known; and
 - b. The name and contact information for an employee of Finalsité whom parents may contact to inquire about the breach.
10. **Reimbursement of Expenses Associated with Security Incident.** In the event of a Security Incident that is attributable to Finalsité, subject to the "Liability Limit" section of the Master Terms and where Finalsité and its Affiliates' aggregate liability does not exceed the amount specified in the Agreement, Finalsité shall reimburse and indemnify LEA for any and all costs and expenses that LEA incurs in investigating and remediating the Security Incident, including but not limited to costs and expenses associated with:
 - a. Providing notification to the parents of those students whose Student Data was compromised and regulatory agencies or other entities as required by law or contract;
 - b. Providing credit monitoring to those students whose Student Data was exposed in a manner during the Security Incident that a reasonable person would believe may impact the student's credit or financial security;
 - c. Legal fees, audit costs, fines, and any other fees or damages imposed against LEA as a result of the Security Incident; and
 - d. Providing any other notifications or fulfilling any other requirements adopted by the Illinois State Board of Education or under other State or federal laws.
11. **Transfer or Deletion of Student Data.** Finalsité shall review, on an annual basis, whether the Student Data it has received pursuant to the DPA continues to be needed for the purpose(s) of the Agreement and this DPA. If any of the Student Data is no longer needed for purposes of the Agreement and this DPA, Finalsité will provide written notice to LEA as to what Student Data is no longer needed. Finalsité will delete or transfer Student Data in readable form to LEA as directed by LEA (which may be

effectuated through **Exhibit D** of the DPA) within 30 calendar days if LEA requests deletion or transfer of the Student Data and shall provide written confirmation to LEA of such deletion or transfer. Upon termination of the Service Agreement between Finalsight and LEA, Finalsight shall conduct a final review of Student Data within 60 calendar days. If LEA receives a request from a parent, as that term is defined in 105 ILCS 10/2(g), that Student Data being held by Finalsight be deleted, LEA shall determine whether the requested deletion would violate State and/or federal records laws. In the event such deletion would not violate State or federal records laws, LEA shall forward the request for deletion to Finalsight. Finalsight shall comply with the request and delete the Student Data within a reasonable time period after receiving the request. Any provision of Student Data to LEA from Finalsight shall be transmitted in a format readable by LEA.

12. **Public Posting of DPA.** Pursuant to SOPPA, LEA shall publish on its website a copy of the DPA between Finalsight and LEA, including this **Exhibit G**.
13. **Subcontractors.** By no later than (5) business days after the date of execution of the DPA, Finalsight shall provide LEA with a list of any subcontractors to whom Student Data may be disclosed or a link to a page on Finalsight's website that clearly lists any and all subcontractors to whom Student Data may be disclosed. This list shall, at a minimum, be updated and provided to LEA by the beginning of each fiscal year (July 1) and at the beginning of each calendar year (January 1).
14. **DPA Term.** Paragraph 4 on page 1 of the DPA setting a three-year term for the DPA shall be deleted, and the following shall be inserted in lieu thereof: "This DPA shall be effective upon the date of signature by Finalsight and LEA, and shall remain in effect as between Finalsight and LEA 1) for so long as the Services are being provided to LEA or 2) until the DPA is terminated pursuant to Section 15 of this Exhibit G, whichever comes first. "
15. **Termination.** Article 7, Section 7.2 shall be deleted, and the following shall be inserted in lieu thereof: "In the event either Party seeks to terminate this DPA, they may do so by mutual written consent so long as the Agreement has lapsed or been terminated. One party may terminate this DPA upon a material breach of this DPA by the other party. Upon termination of the DPA, the Agreement shall terminate."
16. **Privacy Policy.** Finalsight must publicly disclose material information about its collection, use, and disclosure of Student Data, including, but not limited to, publishing a terms of service agreement, privacy policy, or similar document.
17. **Minimum Data Necessary Shared.** Finalsight attests that the Student Data request by Finalsight from LEA in order for LEA to access Finalsight's products and/or services is limited to the Student Data that is adequate, relevant, and limited to what is necessary in relation to the K-12 school purposes for which it is processed.
18. **Student and Parent Access.** Access by students or parents/guardians to Finalsight's programs or services governed by the DPA or to any Student Data stored by Finalsight shall not be conditioned upon agreement by the parents/guardians to waive any of the student data confidentiality restrictions or a lessening of any of the confidentiality or privacy requirements contained in this DPA.
19. **Data Storage.** Finalsight shall store all Student Data shared under the DPA within the United States.
20. **Exhibits A and B.** The Services described in **Exhibit A** and the Schedule of Data in **Exhibit B** to the DPA

satisfy the requirements in SOPPA to include a statement of the product or service being provided to the school by Finalsight and a listing of the categories or types of covered information to be provided to Finalsight, respectively.

EXHIBIT F– SUPPLEMENT STATE TERMS (MASSACHUSETTS)

1. The definition of “Applicable Data Protection Law” includes 603 C.M.R. 23.00, Massachusetts General Law, Chapter 71, Sections 34D to 34H and 603 CMR 28.00.
2. All employees of Finalsight who will have direct contact with students shall pass criminal background checks.

EXHIBIT F – SUPPLEMENT STATE TERMS (NEW YORK)

- 2 The definition of “**Applicable Data Protection Law**” includes New York State Education Law 2-d.
- 3 Finalsite agrees that it will comply in all material respects with those provisions of the “LEA’s Parent’s Bill of Rights for Data Security and Privacy” (“**Parents Bill of Rights**”), a copy of which is attached below that is applicable to Finalsite.
- 4 The detailed security programs and measures in Exhibit D shall include, but not limited to:
 - 4.1 **Employee Training.** Finalsite shall provide periodic security training to those of its employees who operate or have access to the Services.
 - 4.2 **Security Technology.** When the Service is accessed using a supported web browser, Secure Socket Layer (“SSL”), or equivalent technology shall be employed to protect Student Data from unauthorized access. The security measures employed shall include server authentication and data encryption at rest and in transit. Finalsite shall host Student Data pursuant to the Agreement in an environment using a firewall that is maintained according to industry standards.
 - 4.3 In the event of a Security Incident involving Student Data, as defined in Section 6.4, LEA shall (a) upon notification by Finalsite, report the Security Incident to the Chief Privacy Officer, who is appointed by the New York State Education Department; and (b) notify the parent or eligible student of the unauthorized release of Student Data that includes Personally Identifiable Information from the student records of such student in the most expedient way possible and without unreasonable delay. In the case of notification to a parent or eligible student, due to a Security Incident involving Student Data by Finalsite, or its Subprocessors or assignees, and such Security Incident is not originating from LEA’s use of the Service or otherwise a result of LEA’s actions or inactions, Finalsite, if requested by LEA and provided that Finalsite has not previously notified the affected parties, shall promptly reimburse LEA for the full cost of such notification, as required by Education Law §2-d(6)(c).

PARENTS BILL OF RIGHTS FOR DATA PRIVACY AND SECURITY

Pursuant to Section 2-d of the New York State Education Law (“Education Law §2-d”), parents and eligible students are entitled to certain protections regarding confidential student information. Customer, as defined in the Agreement is committed to safeguarding personally identifiable information from unauthorized access or disclosure as set forth below: Any terms not defined herein, shall have the meaning set forth in Education Law §2-d and if not defined in Education Law §2-d, in the Data Processing Addendum (DPA) to which this document is an Exhibit.

1. A student’s personally identifiable information cannot be sold or released for any commercial purposes;
2. Parents have the right to inspect and review the complete contents of their child’s education record maintained by the Customer;

3. State and federal laws protect the confidentiality of personally identifiable information. The Customer is committed to implementing safeguards associated with industry standards and best practices under state and federal laws protecting the confidentiality of personally identifiable information, including but not limited to, encryption, firewalls, and password protection when data is stored or transferred;
4. A complete list of all Student Data elements collected by the State is available for public review at <http://www.p12.nysed.gov/irs/sirs/documentation/NYSEDstudentData.xlsx> or by writing to the NYS Education Department, Information & Reporting Services, Room 863 EBA, 89 Washington Avenue, Albany, NY 12234;
5. Parents have the right to have complaints about possible breaches of student data addressed. Complaints should be directed to the Customer;
6. The Customer has entered into contracts with certain third-party contractors/consultants who have received Student Data and/or teacher data and/or principal data. These contracts will include the following supplemental information:
 - a. The exclusive purpose(s) for which the Student Data will be used;
 - b. The commencement and termination dates of each such contract;
 - c. A description of how the Student Data will be disposed by the contractor upon expiration of the contract;
 - d. If and how a parent, student, eligible student, teacher or principal may challenge the accuracy of the Student Data or teacher or principal data that is collected; and
 - e. The data storage and security measures undertaken for Student Data or teacher or principal data, including whether such data will be encrypted.
7. Agreements with third party contractors/consultants will ensure that the subcontractors, persons or entities that the third party contractor will share the Student Data or teacher or principal data with, if any, will abide by data protection and security requirements.

EXHIBIT F– SUPPLEMENT STATE TERMS (OREGON)

1. The definition of “Applicable Data Protection Law” includes applicable Oregon laws and regulations, including SB 187 (2015), Oregon Student Information Protection Act (“OSIPA”), Or. Rev. Stat. § 646.607 – 646.652; Or. Rev. Stat. § 326.565, et seq. (Student Records), and other applicable state privacy laws and regulations.

EXHIBIT F— SUPPLEMENT STATE TERMS (TEXAS)

1. **Covered Data.** All instances of “Student Data” should be replaced with “LEA Data.” The protections provided within this DPA extend to all data provided to or collected by Finalsight.
2. **Compliance with Texas Privacy Laws and Regulations.** In performing their respective obligations under the Agreement, LEA and Finalsight shall comply with all Texas laws and regulations pertaining to data privacy and confidentiality applicable to LEA Data, including but not limited to the Texas Education Code Chapter 32, and Texas Government Code Chapter 560.
3. **Modification to Section 6.4 of the DPA.** Section 6.4 of the DPA (Data Breach) is amended with the following additions:
 - 6.4.6 For purposes of defining an unauthorized disclosure or security breach, this definition specifically includes meanings assigned by Texas law, including applicable provisions in the Texas Education Code and Texas Business and Commerce Code.
 - 6.4.7 LEA may immediately terminate the Agreement if LEA determines Finalsight has breached a material term of this DPA.
 - 6.4.8 Finalsight’s obligations shall survive termination of this DPA and Agreement until all Student Data has been returned and/or securely destroyed.
4. **Modification to Section 8.4 of the DPA.** Section 8.4 of the DPA (Entire Agreement) is amended as follows:

Entire Agreement. This DPA and the Agreement constitutes the entire agreement of the Parties relating to the subject matter hereof and supersedes all prior communications, representations, or agreements, oral or written, by the Parties relating thereto. This DPA may be amended and the observance of any provision of this DPA may be waived (either generally or in any particular instance and either retroactively or prospectively) only with the signed written consent of both Parties. Neither failure nor delay on the part of any Party in exercising any right, power, or privilege hereunder shall operate as a waiver of such right, nor shall any single or partial exercise of any such right, power, or privilege preclude any further exercise thereof or the exercise of any other right, power, or privilege.
5. **Reimbursement of Expenses Associated with Security Breach.** In the event of a Security Breach that is attributable to Finalsight, subject to the “Liability Limitation” section of the Master Terms and where Finalsight and its Affiliates’ aggregate liability does not exceed the amount specified in the Agreement, Finalsight shall reimburse and indemnify LEA for any and all costs and expenses that LEA incurs in investigating and remediating the Security Breach, including but not limited to costs and expenses associated with:

- a. Providing notification to the employees or parents of those students whose Student Data was compromised and regulatory agencies or other entities as required by law or contract;
- b. Providing credit monitoring to those employees or students whose Student Data was exposed in a manner during the Security Breach that a reasonable person would believe may impact the employee's or student's credit or financial security;
- c. Legal fees, audit costs, fines, and any other fees or damages imposed against LEA as a result of the security breach; and
- d. Providing any other notifications or fulfilling any other requirements adopted by the Texas State Board of Education, Texas Education Agency, or under other State or federal laws.

EXHIBIT F – SUPPLEMENT STATE TERMS (WASHINGTON)

1. The definition of “**Applicable Data Protection Law**” includes applicable Washington laws and regulations, such as the Student User Privacy in Education Rights 28.A.604 et seq. and RCW 42.56.590.
2. **Modification to Section 5.2 of the DPA.** Section 5.2 of the DPA is hereby amended to read as follows:

Authorized Use: The Student Data shared pursuant to the Agreement, including persistent unique identifiers, shall be used for no purpose other than the Services outlined in Exhibit A or stated in the Agreement and/or otherwise authorized under the statutes referred to herein this DPA, unless Processing is required by Applicable Data Protection Laws to which Finalsity is subject, in which case Finalsity shall, to the extent permitted by Applicable Data Protection Laws, inform LEA of that legal requirement before the relevant Processing of that Student Data. Finalsity may use or disclose data to:

- (a) Protect the security or integrity of its website, mobile application or online service.
- (b) Ensure legal or regulatory compliance or to take precautions against liability.
- (c) Respond to or participate in the judicial process.
- (d) Protect the safety of users or others on the website, mobile application or online service.
- (e) Investigate a matter related to public safety.

In undertaking the activities specified in subsections (a) through (e) above, Finalsity shall adhere to all applicable data protections contained in this DPA, as well as Federal and Washington State law.

3. **Modification to Section 5.7 of the DPA.** Section 5.7 is hereby amended to add the following language:
 - (iv) providing recommendations for school, educational, or employment purposes within a school service without the response being determined in whole or in part or other consideration from a third party.





US_FinalSite_Customer_DPA_-_Sept_2022 (4)

Final Audit Report

2023-04-10

Created:	2023-04-07
By:	Kevin Normandeau (kevin.normandeau@finalsite.com)
Status:	Signed
Transaction ID:	CBJCHBCAABAA9lgi7aad2x1PNGjJGoN7qWCRW532nePV

"US_FinalSite_Customer_DPA_-_Sept_2022 (4)" History

-  Document created by Kevin Normandeau (kevin.normandeau@finalsite.com)
2023-04-07 - 8:38:50 PM GMT
-  Document emailed to Jim Calabrese (jim.calabrese@finalsite.com) for signature
2023-04-07 - 8:40:51 PM GMT
-  Email viewed by Jim Calabrese (jim.calabrese@finalsite.com)
2023-04-10 - 11:52:20 AM GMT
-  Document e-signed by Jim Calabrese (jim.calabrese@finalsite.com)
Signature Date: 2023-04-10 - 11:52:33 AM GMT - Time Source: server
-  Agreement completed.
2023-04-10 - 11:52:33 AM GMT

Names and email addresses are entered into the Acrobat Sign service by Acrobat Sign users and are unverified unless otherwise noted.

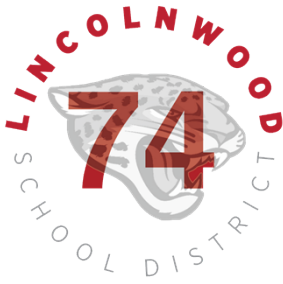

Executive Summary Board of Education Meeting

DATE: June 1, 2023

TOPIC: 2023-2024 School Year PebbleGo Renewal

PREPARED BY: Jordan Stephen

Recommended for:

- Action
- Discussion
- Information

Purpose/Background:

PebbleGo is a curricular content hub specifically designed for K-2 students. The service is packed with informational articles, ready-made activities, and literacy support for students of all abilities. It boosts engagement and fosters independent learning in core subject areas. This product has been in use for many years at Todd Hall and fits the needs of K-2 learners.

In the past students and teachers used to have access to eight different educational modules. In 2021, while conducting a usage assessment, the District scaled back its subscriptions to reflect only those resources that are essential for student use. At the same time, we have asked the vendor to offer a contract that would expire at the end of the 2023 school year to align with our fiscal year. This was all successful and we are now on a cycle that matches our fiscal year.

District Legal Counsel has reviewed the current Terms and Quote for PebbleGo and found them acceptable. No amendment is required nor is any DPA needed as no data is collected and SOPPA would not apply.

Fiscal Impact:

\$1,197 for the use of three modules from PebbleGo. The District paid 1,340.22 for the PebbleGo service during the last contract 2022-2023 school year.

Recommendation:

The Finance Committee concurs with the Administration to recommend to the Board of Education to approve the PebbleGo Contract in the amount of \$1,197 for the 2023-2024 school year.



Capstone
 1710 Roe Crest Drive
 North Mankato, Minnesota 56003
 United States

QUOTE: Q-11889

CAPSTONE QUOTE PREPARED FOR TODD HALL ELEMENTARY SCHOOL

Prepared on: January 11, 2023
 Service start date: July 1, 2023

Payment terms: Net 30

QUOTE PREPARED FOR:

Jordan Stephen
 Todd Hall Elementary School
 3925 W Lunt Ave
 Lincolnwood, Illinois 60712-2597
 P: (847) 675-8235
 jstephen@sd74.org

QUOTE PREPARED BY:

Amy Remington
 (800) 471-8112
 aremington@capstonepub.com

On behalf of:
 Kori Kubitz
 P: (773) 202-0955
 kkorcky5@aol.com

PRODUCTS

PRODUCT	ITEM NUMBER	LIST PRICE	NET PRICE	# OF SITES	MONTHS	TOTAL
PebbleGo Bundle 3-pack	CPQ-PebbleGo-3pack-Bundle			1	12	
PebbleGo Animals	978-1-4296-3699-5	\$399.00	\$399.00	1	12	\$399.00
PebbleGo Social Studies	978-1-6206-5952-6	\$399.00	\$399.00	1	12	\$399.00
PebbleGo Biographies	978-1-4296-6818-7	\$399.00	\$399.00	1	12	\$399.00

" " " }

QUOTE TOTALS

Quote Total: \$1,197.00

Amy Remington

TO SUBMIT YOUR ORDER:

ORDER NOTES:



Capstone
1710 Roe Crest Drive
North Mankato, Minnesota 56003
United States

QUOTE: Q-11889

If you are using a purchase order or submitting payment, choose one:

- Email PO to orders@capstonepub.com
- Fax PO to (888) 517-8978
- Mail PO or payment to Capstone address above

If you are using a credit card:

- Call our Customer Service team at (888) 517-8976
-

Capstone Rewards Number:

- Sign up at www.capstonepub.com
-

RECENT NEWS:

PebbleGo Create with Buncee – integrating an intuitive digital workspace within PebbleGo for students to demonstrate learning and share their knowledge.

Upgrade to Capstone Connect – a comprehensive collection of PebbleGo, Capstone Interactive eBooks and instructional materials.

Receive an additional discount on a 2-year, 3-year or 5-year quote!

Contact me for more information!

DIGITAL LICENSE AGREEMENT

Please read this Agreement carefully. You must agree to the terms of this Agreement to access the Capstone Digital Product.

The terms and conditions contained in this document (the “Standard Terms”) apply to any sales made by Coughlan Companies, LLC d/b/a Capstone of license rights to Capstone Digital Product. These Standard Terms will be binding upon electronic acceptance by You or an authorized representative at Your organization.

AGREEMENT

This Digital License Agreement (the "Agreement") is a legal Agreement between You and Coughlan Companies, LLC d/b/a Capstone, on behalf of itself, its subsidiaries, affiliated companies, joint venturers, business partners, licensors, employees, agents, and third-party information providers ("Capstone"). The parties agree as follows:

AS USED IN THIS AGREEMENT, “YOU” AND “YOUR” REFER TO THE ENTITY RECEIVING THE RIGHT TO USE THE CAPSTONE DIGITAL PRODUCT. THE INDIVIDUAL EXECUTING THIS AGREEMENT DOES SO ON BEHALF OF SUCH ENTITY AND NOT IN HIS OR HER INDIVIDUAL CAPACITY. YOU REPRESENT THAT THE PERSON EXECUTING THIS AGREEMENT IS DULY AUTHORIZED TO BIND YOU TO THE TERMS OF THIS AGREEMENT.

As used in this Agreement, “Capstone Digital Product” shall include all software, text, diagrams, images, photographs, audio, video, compilations or other works of authorship of any kind that are made available to you by Capstone existing now or created in the future via any of Capstone’s digital products or services, including, but not limited to, PebbleGo, PebbleGo Next, Capstone Interactive (CI), and any derivatives of the aforementioned digital products now in existence or created by Capstone in the future.

- 1. Acceptance of Terms.** The terms set forth in this Agreement shall be deemed accepted by the parties upon the earliest of: (i) your installation, access, or use of the Capstone Digital Product, its Product, and any related documentation (in whole or in part, the “Capstone Digital Product”) or; (ii) Your execution of this Agreement.
- 2. Grant of License.** Capstone grants to You, Your students, Your faculty and building Guests, for the term of this Agreement, a non-exclusive, non-transferable and non-assignable Building Specific Site License to access and view Capstone Digital Products solely for Your internal, non-commercial use in connection with their

studies and work at the Building and in accordance with the terms of this Agreement, in the United States and worldwide. “Building Specific Site License” shall mean that this license is strictly limited to a site license granted to you on a per building basis. This Building Specific license allows all of Your students that attend and faculty that work in the licensed Building identified by You when purchasing this license, to access and view the Capstone Digital Product. Those students and faculty of the identified Building may also view and access the Capstone Digital Product at home. Individuals who do not remain students or faculty of the Building shall have no ongoing right to view or access the Capstone Digital Product. In the case of consortium, district, regional center, state or other entities consisting of multiple institutional Buildings of any type, a site license is required for each Building with students or faculty accessing or viewing the Capstone Digital Product. For the purposes of clarity, a “Building” is defined as having a unique mailing address and principal, director or manager. You are solely responsible for providing the required facilities, hardware, software (including third-party software), services and systems (including telecommunications and bandwidth, electrical and physical systems), for You, Your students and Your faculty to access and view the Capstone Digital Product.

- 3. Payment.** By entering into this Agreement, you agree to be bound by the payment terms set forth by Capstone for the license granted to the Capstone Digital Product. Failure to abide by the payment terms set forth by Capstone may, at Capstone’s discretion, automatically terminate this Agreement including without limitation all of your license rights to the Capstone Digital Product. Any acceptance of partial payment, reduced payment, or late payment by Capstone shall not constitute a waiver as to Capstone’s right to recover full amounts due under the payment terms and Capstone’s right to terminate this Agreement for non-payment.
- 4. Restrictions on Use.** You may not do any of the following, nor may you permit any of your students or faculty, or any third party, to do any of the following: (i) exceed the limited license rights granted in this Agreement including, without limitation, the sharing of passwords or other login credentials with those not given explicit rights to access and view Capstone Digital Product under this Agreement; (ii) remove any proprietary notices, labels, or marks from Capstone Digital Product, (iii) sell, transfer, lend, lease, license, or sublicense Capstone Digital Product, (iv) copy, distribute, display, perform, modify, or create derivative works from Capstone Digital Product or circumvent any digital rights management or copyright management protection associated with the Capstone Digital Product, or (v) translate, reverse engineer, decompile or disassemble Capstone Digital Product or the hardware, executable software, software source code, or any other technology used as a means for delivering the Capstone Digital Product or securing Capstone’s rights in the

Capstone Digital Product including without limitation any digital rights management or copyright protection. In addition, you agree and are responsible for ensuring that neither you nor your students or faculty will use any website, ftp site, media, or other methods or materials provided by Capstone for your access and viewing of Capstone Digital Product for any purpose beyond that which is explicitly contemplated in this Agreement.

- 5. Ownership.** As between you and Capstone, Capstone is the owner of all Intellectual Property rights in and to Capstone Digital Product and any information, suggestions, comments, or other materials You, Your students, or Your faculty submit to Capstone. “Intellectual Property” shall mean all of the following, arising under equity or law, whether or not filed, perfected, registered or recorded anywhere in the world: all patents and applications for patents; all copyrights, copyright registrations and copyright applications, copyrightable works, and all other corresponding rights; all trade dress and trade names, logos, trademarks and service marks and related registrations and applications, all other indicia of commercial source or origin, and all goodwill associated with any of the foregoing; and, all trade secrets and confidential information of any kind. The license granted under this Agreement is not a sale of Capstone Digital Product or any copy of Capstone Digital Product and does not grant you any ownership rights to or in any copies of Capstone Digital Product. Ownership of Capstone Digital Product and copies thereof will at all times remain with Capstone (or its licensors), regardless of who may be deemed the owner of the tangible media in or on which Capstone Digital Product may be copied, encoded or otherwise fixed.
- 6. Duration of Access to Capstone Digital Product.** Capstone will provide access to the Capstone Digital Product in a form and format that is in the sole discretion of Capstone. Due to licensing restrictions, Capstone reserves the right to remove, modify or replace the Products of the Capstone Digital Product in its sole discretion.

 - a. Under a Subscription License:** In the event that a content must be removed from the Capstone Digital Product, You, the customer, will remain whole and in possession of that content until the end of Your annual subscription, at which time the content will be removed from the Capstone Digital Product.
 - b. Under a Perpetual License:** In the event that content must be removed from the Capstone Digital Product, You, the customer, will remain whole.
- 7. Term & Termination.** This Agreement will terminate automatically and immediately in the event that You violate any provision of this Agreement. On termination, You must destroy all copies of the Capstone Digital Product in Your

possession or control, cease any and all attempts at accessing or viewing Capstone Digital Product by You, Your students and Your faculty, and upon Capstone's request, you shall provide written and signed certification of such destruction.

- a. **Under a Subscription License:** This Agreement will begin on the Order Date and will, unless earlier terminated in accordance with this section, continue in effect until, with respect to Subscription Software, the end of the last Subscription Term covered by this Agreement. You shall be responsible for any and all fees charged by Capstone for the license granted under this Agreement and for any subsequent renewals.
- b. **Under a Perpetual License:** The material contemplated under this Agreement shall be granted to You as a Perpetual License. For purposes of this Agreement, a 'Perpetual License' to the Capstone Digital Product shall mean that the material will be made available to You for as long as said material is owned, maintained and made available by Capstone in the form of the Capstone Digital Product purchased under this Agreement.

8. Disclaimer of Warranties. CAPSTONE DIGITAL PRODUCT AND ALL METHODS AND MEDIA THROUGH OR ON WHICH IT IS PROVIDED INCLUDING WITHOUT LIMITATION ANY HOSTING OR PROVISION OF CAPSTONE DIGITAL PRODUCT THROUGH THE INTERNET IS PROVIDED BY CAPSTONE AND ACCEPTED BY YOU "AS IS," "WITH ALL FAULTS," AND WITHOUT ANY WARRANTY WHATSOEVER. ALL WARRANTIES, EXPRESS OR IMPLIED, INCLUDING, WITHOUT LIMITATION, ANY IMPLIED WARRANTIES OF MERCHANTABILITY, FITNESS FOR ANY PARTICULAR PURPOSE, TITLE OR NON-INFRINGEMENT, ARE SPECIFICALLY EXCLUDED AND DISCLAIMED BY CAPSTONE. CAPSTONE DOES NOT WARRANT THAT THE ACCESS TO CAPSTONE DIGITAL PRODUCT OR CAPSTONE DIGITAL PRODUCT WILL BE UNINTERRUPTED OR ERROR-FREE, THAT DEFECTS WILL BE CORRECTED, OR THAT ANY WEBSITE OR SERVER THAT MAKES CAPSTONE DIGITAL PRODUCT AVAILABLE IS FREE OF VIRUSES OR OTHER HARMFUL COMPONENTS. CAPSTONE DOES NOT WARRANT OR MAKE ANY REPRESENTATION REGARDING USE, OR THE RESULT OF USE, OF THE CAPSTONE DIGITAL PRODUCT IN TERMS OF ACCURACY, RELIABILITY, OR OTHERWISE. THE CAPSTONE DIGITAL PRODUCT MAY INCLUDE TECHNICAL INACCURACIES OR TYPOGRAPHICAL ERRORS.

9. Limitation of Liability. TO THE GREATEST EXTENT PERMITTED BY APPLICABLE LAW, CAPSTONE WILL NOT BE LIABLE FOR ANY LOSS OR

DAMAGE ARISING EITHER DIRECTLY OR INDIRECTLY FROM ANY USE OF OR INABILITY TO USE, ACCESS, OR VIEW CAPSTONE DIGITAL PRODUCT. YOU UNDERSTAND AND AGREE THAT UNDER NO CIRCUMSTANCES WILL CAPSTONE BE LIABLE FOR ANY DAMAGES WHATSOEVER, INCLUDING, BUT NOT LIMITED TO, ANY DIRECT, INDIRECT, INCIDENTAL, CONSEQUENTIAL, OR EXEMPLARY DAMAGES ARISING OUT OF THE USE OF OR INABILITY TO USE CAPSTONE DIGITAL PRODUCT, EVEN IF CAPSTONE HAS BEEN ADVISED OF THE POSSIBILITY OF SUCH DAMAGES, REGARDLESS OF THE LEGAL CAUSE OF ACTION ASSERTED. BECAUSE SOME STATES DO NOT ALLOW THE EXCLUSION OR LIMITATION OF LIABILITY FOR CONSEQUENTIAL OR INCIDENTAL DAMAGES, SOME OF THE ABOVE LIMITATIONS MAY NOT APPLY TO YOU. IN SUCH STATES, CAPSTONE'S LIABILITY IS LIMITED AND WARRANTIES ARE EXCLUDED TO THE GREATEST EXTENT PERMITTED BY LAW AND IN NO EVENT SHALL EXCEED THE AMOUNT PAID BY YOU FOR THE LICENSE GRANTED HEREIN.

10. Indemnification. To the extent permitted by applicable law, You are legally responsible for any inappropriate access, viewing, or other misuse of Capstone Digital Product that occurs in violation of, or outside of, the rights granted in this Agreement whether by you, your students, your faculty, or any third party that gains access to the Capstone Digital Product by or through your, your students', or your faculties' actions or inactions (collectively "Inappropriate Behavior"). Unless You are a publicly funded, non-profit educational institution and therefore unable to legally indemnify Capstone, to the extent permitted by applicable law, You agree to indemnify, defend and hold harmless Capstone, its officers, directors, and employees from and against any and all claims, losses, expenses, damages (including, but not limited to, direct, indirect, incidental, consequential, and exemplary damages), liabilities, and costs (including reasonable attorneys' fees, expert fees, and other litigation or investigation costs), whether for defense or prosecution of any of Capstone's, or Capstone's licensors', Intellectual Property rights or other rights under this Agreement resulting from or arising out of your use of or inability to use Capstone Digital Product, any violation by you of this Agreement, and any Inappropriate Behavior.

11. General Provisions.

- a. Entire Agreement.** This Agreement and the related documents referenced herein constitute the entire agreement of the parties with respect to the subject matter hereof, and supersedes all previous written or oral agreements between the parties with respect to such subject matter. Some

Capstone Digital Product itself may contain additional terms of use. To the extent of any inconsistency between the terms of this Agreement and any additional terms of use contained in Capstone Digital Product itself, the terms and conditions of this Agreement shall control.

- b. No Waiver.** No waiver by either party of any breach or default hereunder shall be deemed to be a waiver of any preceding or subsequent breach or default.
- c. Severability.** If any provision of this Agreement is found to be invalid or unenforceable, that provision will be enforceable to the maximum extent permissible, and the other provision of the Agreement will remain in force.
- d. Force Majeure.** Either party will not be liable for, nor will be considered to be in breach of or default under, this Agreement on account of any delay or failure to perform as required by this Agreement as a result of any causes or conditions that are beyond the party's reasonable control and that either party is unable to overcome through the exercise of commercially reasonable diligence. If any force majeure event occurs, Capstone will give prompt notice to you and will use commercially reasonable efforts to minimize the impact of the event. This clause in no way abrogates or limits the Disclaimer of Warranty, Limitation of Liability, and Indemnification provisions otherwise set forth in this Agreement.
- e. Enforcement.** If You are a publicly funded, non-profit educational institution, this Agreement will be governed by the internal laws of the State in which You are situated, without regard to its 'conflicts of laws' rule. In all other cases, this Agreement will be governed by the internal laws of the State of Minnesota.
- f. Assignment.** Your rights under this Agreement are not assignable or transferable (by operation of law or otherwise). This Agreement will be binding upon and inure to the benefit of the parties and their respective successors and permitted assigns. No third-party beneficiaries are intended or shall be construed as created by virtue of this Agreement, including without limitation, the parties agree that Your students and faculty are not third-party beneficiaries to this Agreement.
- g. Student Data.** Capstone does not collect any personally identifiable information (PII) or data through the digital products contemplated under this Agreement.

- h. Modifications to Agreement.** Capstone reserves the right to make any necessary changes, modifications or updates to this Agreement. Should Capstone make any changes to this Agreement, customer will be required to agree to the updated terms and accept the updated Agreement before continued use of the product.
- i. General Contact Information.** If you have any questions about this Agreement, you may contact Capstone via fax (888-262-0705); mail (1710 Roe Crest Drive, North Mankato, MN 56003); or email (support@capstonepub.com; legal@capstonepub.com).



Executive Summary Board of Education Meeting

DATE: June 1, 2023

TOPIC: Annual Renewal of Formative at Rutledge Hall for 2023-2024

PREPARED BY: Jordan Stephen

Recommended for:

- Action
- Discussion
- Information

Purpose/Background:

Formative is a cloud-based assessment platform that provides feedback and keeps students engaged, accountable in both virtual and traditional classrooms. Formative provides teachers with real-time information on student work and allows for immediate intervention and support. With Formative, teachers have assessment options such as advanced question types, student growth tracking, and the ability to co-teach and collaborate on assessments, benefitting the teaching and learning environment. Formative provides the staff with the tools needed to match the Illinois Learning Standards to assessments that can be shared across the grade level to help make data-informed decisions on mastery of a subject.

During the 2022-2023 school year, Formative was used by over 70% of the core teaching staff at Rutledge Hall, collecting and sharing data on assessments within the classrooms.

The District's Legal Counsel has reviewed the Terms of Service and Privacy agreements and found them acceptable. Counsel also noted that we have our standard amendment on file that has been signed by the vendors. The District also has an Exhibit E on file to cover aspects of the National Data Privacy Agreement (IL-NDPA) and the Student Online Personal Protection Act (SOPPA)

Fiscal Impact:

\$3,515.89. The District paid Formative the same amount of \$3,515.89 during the 2022-2023 school year.

Recommendation:

The Finance Committee concurs with the Administration to recommend to the Board of Education to renew the Formative license at Rutledge Hall for the amount of \$3,515.89 for services between July 1, 2023 and June 30, 2024.

Formative

Quote Title	Formative and Rutledge Hall Elementary, 2023-2024	Creation Date	1/17/2023
Company Address	1158 26th Street, #161 Santa Monica, California 90403 United States	Expiration Date	6/30/2023
Prepared By	Sara Cowley	Contact Name	Jordan Stephen
Email	sara.cowley@formative.com		
Bill To Name	Jordan Stephen	Ship To Name	Jordan Stephen
Bill To	6950 N East Prairie Rd Lincolnwood, Illinois 60712-2520 United States	Ship To	6850 E Prairie Rd LINCOLNWOOD, 60712

Product	Line Item Description	Service Year	Start Date	End Date	Quantity	Unit Price	Total Price
Standard Formative License	Formative Partner Licenses for 390 Students and All Associated Admin and Educators	2023	7/1/2023	6/30/2024	390.00	\$9.02	\$3,515.89
Total Price							\$3,515.89

Notes & Terms

Description Subscription Term: July 1, 2023 - June 30, 2024

Terms To place your order, please email a signed copy of this Proposal to the email address listed on this quote. By signing and returning this proposal or sending to us any Student Data for implementation, you are deemed to have accepted this proposal and all Terms of Service and other Policies associated with it. Customer agrees that if its internal procedures require that a purchase order be issued as a prerequisite to payment of any amounts due to Formative, it will timely issue such purchase order and inform Formative of the number and amount thereafter.

Quote Acceptance Information

Signature _____
 Name _____
 Title _____
 Date _____

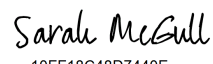
DocuSigned by:

 10E18G48DZ449E...
 Sarah McGull
 Director of Client Success
 Formative
 1/18/2023



IT Security and Privacy Statement

6/14/22

Smartest Edu, Inc., d/b/a Formative, places great importance on data privacy and information security in order to protect against external threats and malicious insiders. Formative's IT Security and Data Privacy strategy prioritizes detection, analysis, and response to known, anticipated, or unexpected threats; this strategy also emphasizes the effective management of risks as well as resilience against data incidents. Formative continuously strives to meet or exceed the industry's information-security best practices and applies controls to protect our clients and the organization. In addition to adhering to all applicable state, federal, and international privacy laws, Formative maintains a formal Privacy and Compliance Program structured around the following:

- U.S. Sentencing Guidelines: Seven Elements of an Effective Compliance Program
- National Institute of Standards and Technology (NIST) Cybersecurity Framework (CSF)
- General Data Protection Regulation (GDPR)
- ISO 27001
- System and Organization Controls (SOC 2)

For more information, please review [this document](#), which provides an overview of Formative's Best-In-Class approach to information security, data privacy, and its practices to secure data, systems, and services.

Data Protection Safeguards

EMPLOYEE BACKGROUND CHECKS

Formative maintains a high level of ethical standards that are defined and enforced through Formative's code of conduct as well as the Privacy and Compliance Plan.

Formative requires confidentiality and nondisclosure from all those who work for and with Formative, both during and after engagement. All Formative employees undergo background checks and sign a non-disclosure agreement before hire. Formative carefully screens people who do work for, or on behalf of, the company.

Formative enforces disciplinary action for noncompliance with Formative policies.

EMPLOYEE PRIVACY & SECURITY AWARENESS TRAINING

Upon hire and on an ongoing basis, all employees are required to undertake privacy and security training, both of which cover privacy practices and the principles that apply to the proper handling of personal information, including (but not limited to) placing limitations on using, accessing, sharing, and retaining personal information.

We provide training on specific aspects of security that employees require based on their specific roles.

INCIDENT MANAGEMENT

Formative has a written Incident Response Plan that details the processes for detecting, reporting, identifying, analyzing, and responding to Security and Privacy Incidents that affect Formative Systems and Client Data.

VENDOR SELECTION & RISK MANAGEMENT

Formative Systems may use sub-processors to perform services; these sub-processors are only entitled to access customer data as needed in order to perform services and shall be bound by written agreements that require sub-processors to provide strict levels of data protection as required by Formative and all applicable regulations. For a list of our sub-processors, please review the “Third Parties” section in [Formative’s Privacy Principles](#).

Formative conducts pre-engagement and ongoing vendor assessments to ensure that proper data privacy and security practices are in place throughout the vendor relationship.

Changes to existing contracts or to vendor services require a security-risk assessment in order to confirm that the changes do not present additional or undue risks.

DATA BREACH NOTIFICATION

If Formative learns of a data breach, we will follow our Incident Response Plan and notify our customers without undue delay.

POLICY & PROCEDURE DOCUMENTS ALIGN WITH NIST CSF, SOC 2, GDPR, & ISO

Formative reviews its systems against applicable state, federal, and internal regulations as well as against controls associated with NIST CSF, SOC2, GDPR, and ISO. Formative accordingly addresses any identified risks or gaps.

We have a designated Privacy and Compliance Committee that holds quarterly meetings in order to ensure data integrity.

POLICIES & STANDARDS

Formative maintains comprehensive policies and standards for information security and data protection that take into consideration data-privacy laws and regulations, including data-retention requirements, that are applicable to jurisdictions in which Formative operates.

The Privacy and Compliance Committee reviews and approves these policies and standards. Formative annually reviews its Global Privacy and Compliance Program, and we review other policies and standards at least every three years in accordance with company policy.

Formative's Privacy and Compliance Committee, which consists of representatives from various business units, maintains the process to develop, review, update, and decommission information security alongside privacy policies and standards. Additionally, changes in the risk environment or regulatory landscape may also trigger reviews.

Formative aligns its policies and standards to all applicable state, federal, and international privacy laws as well as with recognized industry standards, including (but not limited to) the following:

- U.S. Sentencing Guidelines: Seven Elements of an Effective Compliance Program
- National Institute of Standards and Technology (NIST) Cybersecurity Framework (CSF)
- General Data Protection Regulation (GDPR)
- ISO 27001
- System and Organization Controls (SOC 2).

Formative makes its policies and standards available to all personnel. These materials cover every aspect of the Information Security and Privacy Program, including the following:

- Identity and Access Management: for example, entitlement management and production access
- Application and Software Security: for example, software-change management, backup, and restoration
- Infrastructure Security: for example, capacity management, vulnerability management, and network & wireless security
- Mobile Security: for example, Bring Your Own Device (BYOD) and mobile applications
- Data Security: for example, cryptography, encryption, database security, data erasure, and media disposal
- Cloud Computing: for example, governance & security of cloud applications as well as Software-as-a-Service data onboarding
- Working-from-Home Best Practices: for example, safe data handling, clean desk guidelines, social engineering, and phishing awareness

Technical Safeguards

DATA ENCRYPTION

Data is encrypted in transit and at rest.

DATA RETENTION & DELETION

Formative has implemented a Data Retention Policy. Where appropriate, our solutions utilize automated rules to purge data according to this policy.

DATA BACKUP & BUSINESS CONTINUITY

We perform regular backups of data and systems. Backup intervals depend on the type of data, and they range from minutes to once per day.

Formative has a documented Business Continuity Plan, recovery procedures, and a trained response team. At a minimum, Formative tests the Business Continuity Plan and recovery procedures twice annually and incorporates any improvements into the Plan.

As an engineering principle, Formative applies redundancies, including self-healing features built into the platform that automatically adjust to outages wherever possible.

VULNERABILITY REMEDIATION

Formative has a Vulnerability Remediation policy to identify and remediate vulnerabilities according to the risk they present. We utilize monitoring and management software in order to monitor systems and to ensure that patches are implemented.

MALWARE PROTECTION

Formative has anti-malware and anti-spam solutions in place to protect servers and workstations.

LOGGING & MONITORING

Formative uses logging and monitoring solutions to identify and investigate possible security events.

IDENTITY & ACCESS CONTROL

Through login credentials, Formative limits access to personal information to only those employees who require such information in order to perform their job functions. Furthermore, Formative uses access controls such as Multi-Factor Authentication, Single Sign-On, least privilege & access on an as-needed basis, strong password controls, and restricted access to administrative accounts.

INFORMATION SECURITY & PRIVACY

Formative maintains an Information Security and Privacy Program which, along with security personnel embedded in each of our business units, consists of a centralized group that establishes information security mandates, evaluates adherence to these mandates, and detects & responds to incidents. Formative frequently adjusts this program to ensure ongoing suitability.

The Information Security and Privacy Program regularly assesses the sufficiency of Formative's controls. Additionally, the Program coordinates quarterly assessments of control efficacy and heightened residual risks through the IT Security and Privacy program.

Formative's Data Protection Officer (DPO) is responsible for managing and implementing the Information Security and Privacy Program and reports directly to the CFO (with dotted lines to our CEO and COO). The DPO's responsibilities include setting organization-wide control requirements, assessing adherence to controls, identifying & prioritizing data-privacy risks, and detecting & responding to incidents. The DPO reports the overall status of the information security and privacy program at quarterly intervals to the Privacy and Compliance Committee.

PENETRATION TESTS

No less than twice a year, Formative employs external firms to perform regular penetration testing.

NETWORK & COMMUNICATIONS

Formative hardens all network services and firewalls and employs continuous compliance monitoring that checks for changes to our standard configurations.

We use segregation principles at multiple levels for security, redundancy, and performance. Formative also requires NDAs from all parties that have or may have access to sensitive information resources.

SAAS ARCHITECTURE

Formative follows best practices for its system deployment and maintenance and for data maintained within AWS data centers and cloud services. We replicate and back up critical data and systems to secondary data centers. Formative has securely designed these systems, and the security & development teams review them before we put our systems into production.

COOKIE MANAGEMENT

Although Formative uses cookies to operate our sites, we have deployed a robust, best-in-class, cookie-management tool for all visitors and clients, a tool that allows each individual complete control of their personal data.

Risk Management

OUR APPROACH TO RISK MANAGEMENT

In order to provide appropriate risk governance, Formative employs a three-lines-of-defense model that offers accountability, oversight, and assurance. This model organizes risk-management activities across Formative's business units that own and manage risk (first line), perform independent-risk oversight functions (second line), and conduct an external audit (third line).

Within the first line, Formative's Privacy and Compliance Program establishes information security, outlines privacy standards, and sets clear expectations for Formative's adherence to these standards. Each business unit must understand any applicable controls and then abide by them. The Privacy and Compliance Committee functions as the second line and has oversight over the auditing of Formative's business-unit activities. Finally, Formative's External Audit acts as the third line, and it independently evaluates the company's control environment.

CERTIFICATIONS & AUDITS

Formative is proud to maintain a SOC 2 certification; in addition, reputable external auditing agencies audit us annually on our security standards.

Formative is currently GDPR-compliant and will be ISO 27001-certified and NIST CSF-compliant by the end of 2022.

We also perform regular internal audits to assess Formative's overall control environment; raise awareness of risks; communicate and report on the effectiveness of Formative's governance, risk management, and controls that mitigate current and evolving risks; and monitor the implementation of Management's control measures. Internal Audit is an independent function that reports to the Privacy and Compliance Committee.

Our customers also regularly audit Formative. We respond to these audits seriously, and we value the feedback from our customers.

AMENDMENT TO AGREEMENT BETWEEN THE BOARD OF EDUCATION OF LINCOLNWOOD SCHOOL DISTRICT 74 AND FORMATIVE

This Amendment is entered into as of July 1, 2023, by and between the Board of Education of Lincolnwood School District No. 74 (“School District”) and Formative (“Formative”) pursuant to Quote Number 00001103 dated March 15, 2022, and the Terms of Service (collectively, the “Agreement”), and shall continue in force for any extensions of the Agreement or subsequent renewals or order forms, unless otherwise agreed by the Parties.

1. **Terms and Conditions.** This Amendment modifies the Agreement entered into by the Parties. Terms and conditions not amended herein shall have the same meaning as in the Agreement. If there is conflict between this Amendment and the Agreement, the terms of this Amendment will prevail. Formative shall not materially modify or amend the Agreement (see <https://www.formative.com/legal/terms>) during the term of this Agreement or any extension thereof, without providing written notice.
2. **Auto-Renewal.** The term of the Agreement between the parties shall not automatically renew. Subsequent extensions of the Agreement shall require notice to and approval of the School District.
3. **FOIA/OMA.** School District shall not be required to make any claim of privilege that may be applicable to prevent disclosure in response to, and will not be required to notify Formative prior to any disclosure in response to, a valid FOIA request for information that is not confidential or proprietary. Formative acknowledges and agrees that the Agreement is not confidential or exempt from disclosure under the Illinois Freedom of Information Act or Open Meetings Act.
4. **Governing Law/Venue.** This Agreement will be governed and construed in accordance with the laws of the State of Illinois, without regard to any conflicts of law provisions. Venue for all actions between the parties shall lie solely in the Circuit Court of Cook County, Illinois. Formative hereby agrees to this exclusive venue, to personal jurisdiction of this court, and to service of process in accordance with its rules of civil procedure, and Formative waives any objection that this venue is not convenient. Any references to binding arbitration shall be deleted from the Agreement.
5. **Illinois Student Privacy Laws.** In addition to its obligation to maintain student data in accordance with applicable federal laws, Formative shall also maintain all student data obtained from School District in accordance with any applicable Illinois laws, including (without limitation, and only to the extent applicable) the *Illinois School Student Records Act* (105 ILCS 10/1 *et seq.*); and the *Illinois Student Online Personal Protection Act* (105 ILCS 85/1 *et seq.*) (herein “SOPPA”). In accordance with SOPPA, the School District has separately executed an Exhibit E “General Offer of Privacy Terms” to join in the IL-NDPA Agreement between Formative and another Illinois public school district.

6. **Insurance.** During the term of this Agreement and any renewal thereof, Formative shall maintain a cyber-liability insurance policy insuring against data breaches. School District shall be named as an additional insured on such policy. Any damages limitations in this Agreement shall not apply to School District in its capacity as an additional insured.

7. **Authority to Execute.** Each signatory hereto represents and warrants that he or she has the proper corporate authority to execute this Amendment and bind his or her entity to the terms and conditions hereof.

WHEREAS, this Amendment and its terms and conditions are agreed upon by the Parties on the date set forth above.

**BOARD OF EDUCATION OF
LINCOLNWOOD SCHOOL DISTRICT 74**

FORMATIVE

By: _____

Its: _____

Date: _____

Justin Kresevic, Proposal Manager

By: _____

Its: _____

Date: _____

DocuSigned by:
Justin Kresevic
FEC4D94B7C314FA...

5/10/2023

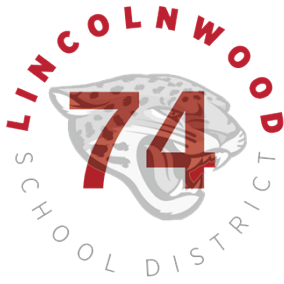

Executive Summary Board of Education Meeting

DATE: June 1, 2023

TOPIC: Renewal of Seesaw for Schools for Todd Hall for 2023-2024

PREPARED BY: Jordan Stephen

Recommended for:

- Action
- Discussion
- Information

Purpose/Background:

Seesaw is a Learning Management System (LMS) that allows teachers at Todd Hall to create and share online activities and assignments with students and communicate with families. Students use creative tools to write, draw, take pictures, and record videos in order to capture their learning and receive feedback. Teachers at Todd Hall continue to use this subscription service to access features that greatly enhance collaboration and co-teaching opportunities, provide unlimited activities, and share an activities library for the entire building, whether that instruction takes place online or in person.

The District's Legal Counsel reviewed Seesaw's Terms and Conditions and Privacy Policy. Counsel has presented a new amendment to Seesaw's Terms of Service, prepared by the District's Legal Counsel. This amendment was accepted and signed by the vendor. Counsel also offered an opinion related to the National Data Privacy Agreement (IL-NDPA) and the Student Online Personal Protection Act. Currently the District has an Exhibit E on file based upon the Johnsburg CUSD #12 agreement. This agreement will expire during the school year, but will be renewed once the vendor signs a new IL-NDPA during the 23-24 school year.

Fiscal Impact:

\$3,120 The District paid Seesaw \$2,400 for the 2022-2023 school year.

Recommendation:

The Finance Committee concurs with the Administration to recommend to the Board of Education to accept the Seesaw license for Seesaw for Schools for the amount of \$3,120 from August 1, 2023 through July 31, 2024.



Company Address 548 Market St.
PMB 98963
San Francisco, CA 94104
United States

Please send any billing questions to ar@seesaw.me

Bill To Name Todd Hall
Created Date 1/27/2023
Expiration Date 5/28/2023
Quote Number 00055223

Contract Summary

Contract Start Date 8/1/2023
of Students 427.00
Total Price USD 3,120.00
Grand Total USD 3,120.00

Contract End Date 7/31/2024

For non-US customers only:

Do you have a VAT/GST registration number or equivalent?

If yes, enter registration number here: _____

Contract Details

Product	Quantity	Sales Price	Total Price	Invoice Date
Seesaw - School	1.00	USD 3,120.00	USD 3,120.00	8/1/2023

Admin Sponsor (e.g. Principal, Director of Instructional Tech, etc.)

Decided to purchase (or renew) Seesaw. Will be included in conversations about our partnership progress.

Name: Jordan Stephen

Email: jstephen@sd74.org

Title: Director Of Technology

Phone: 847-675-8234

Seesaw Lead

Responsible for Seesaw training and adoption. Main Seesaw point of contact throughout the contract.

Name: Jordan Stephen

Email: jstephen@sd74.org

Title: Director Of Technology

Phone: 847-675-8234

Tech Lead (Who can help set up your school?)

Lead for Seesaw's technical implementation. Point of contact for technical issues or updates.

Name: Jordan Stephen

Email: jstephen@sd74.org

Title: Director Of Technology

Phone: 847-675-8234

Billing Contact - Accounts Payable (Who will pay the invoice?)

Receives invoices. Point of contact on payment-related matters.

Name: Sylvia Hernandez

Email: shernandez@sd74.org

Title: _____

Phone: 847-675-8234

School Address

Address: 6950 East Prairie Road

City: Lincolnwood



State: Illinois

Zip / Post Code: 60712

Upon signing by Customer and submission to web.seesaw.me or your sales representative, this Order Form shall become legally binding unless this Order Form is rejected by Seesaw Learning, Inc. for any of the following reasons: (1) the signatory below does not have the authority to bind Customer to this Order Form, (2) changes have been made to this Order Form (other than completion of the purchase order information and the signature block), or (3) the requested purchase order information or signature is incomplete or does not match our records or the rest of this Order Form.

This Order Form is governed by the terms of the Seesaw Learning, Inc. Master Services Agreement ("Agreement") found at <https://web.seesaw.me/msa> unless (i) Customer has a written master services agreement executed by Seesaw Learning, Inc. for the Services, in which case such written subscription agreement will govern or (ii) otherwise set forth herein. By signing below, the parties agree to be bound by the Agreement.

Name: _____

Date: _____

Company: _____

Title: _____

Email: _____

PO Number (if required): _____

Accepted By: _____

Seesaw Signature

Name: Sarah Kuhn

Company: _____

Accepted By: _____

Date: 1/27/2023

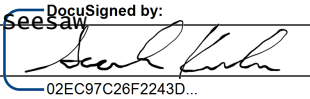

**ADDENDUM TO SEESAW CONTRACT
Lincolnwood School District 74 – 2022-23 Contract Year**

This Addendum modifies the contract for services between Seesaw and the Board of Education of Lincolnwood School District No. 74, Cook County, Illinois, beginning
In consideration of the mutual promises by Seesaw and Lincolnwood School District 74 in the Contract and this Addendum, the parties agree that the following terms will apply to this Contract and any extensions or renewals, and will supersede the online Terms of Service as they exist now or as they may be amended from time to time:

1. Any indemnification of Seesaw by the School District shall not include attorneys' fees or costs. Should Seesaw exercise any right to assume the exclusive defense and control of any matter for which the School District is required to indemnify Seesaw, Seesaw shall be responsible for the costs of doing so, including attorneys' fees.
2. Seesaw shall indemnify and hold harmless the School District from any and all claims, suits, actions, losses, costs, damages, and any other liabilities arising out of or related to Seesaw's breach of this contract or failure to perform. Seesaw's total liability to the School District for all damages, losses, or causes of action arising out of or relating to this contract shall not exceed: (1) the amounts paid to access Seesaw during the eighteen (18) months immediately preceding the date of claim, or (2) two thousand U.S. dollars, whichever is greater.
3. The laws of the State of Illinois govern this agreement, as well as any dispute, claim, or controversy that may arise between the School District and Seesaw, without regard to conflicts of law provisions.
4. All references to arbitration in the online Terms of Service are hereby deleted. The venue for any dispute resolution between the parties shall be in the Circuit Court of Cook County, Illinois, and Seesaw hereby submits to the jurisdiction of that court.

IN WITNESS WHEREOF, the parties hereto have caused this Addendum to be executed by their authorized representatives, effective as of the date first set forth above.

Seesaw, Inc Digitally signed by:
 By 
CCEC4D275E584ED...
 Its: Megan Bradley Counsel
 Date: 4/28/2022

Lincolnwood School District 74
 By _____
 Date: _____



Executive Summary Board of Education Meeting

DATE: June 1, 2023

TOPIC: Renaissance Learning Renewal of FastBridge for 2023-2024

PREPARED BY: David Russo

Recommended for:

- Action
- Discussion
- Information

Purpose/Background:

The FAST (Formative Assessment System for Teachers) system was developed based on research from the University of Minnesota in 2003. It includes both curriculum-based measures (for screening and progress monitoring) and computer-adaptive assessment measures (for diagnostic). This tool has been used across the Township since 2018 as an evaluation to benchmark all students in reading and math and progress monitor ongoing performance for those students receiving academic support services.

In 2018, the Board approved an initial Agreement for FastBridge. Up to this point, the Niles Township District for Special Education (NTDSE) managed the account for the Township and billed member districts. This year, NTDSE informed us that each district would be responsible for managing and renewing their account.

Since the original adoption, the FastBridge platform has been purchased by Renaissance Learning. Therefore, Legal Counsel reviewed the previous Terms and Conditions and Amendment signed in 2018. Counsel determined a new Amendment with Renaissance Learning should be authored. The vendor agreed to all terms. Additionally, an Illinois-National Data Privacy Agreement (IL-NDPA) was authored for SOPPA compliance. Again, Counsel reviewed this document and it met with approval.

Fiscal Impact:

\$7,080.06

Recommendation:

The Finance Committee concurs with the Administration to recommend to the Board of Education to approve this Agreement with Renaissance Learning for renewal of FastBridge for the 2023- 2024 school year in the amount of \$7,080.06.

RENAISSANCE



March 23, 2023

Lincolnwood School District 74

ATTN: Ms. Jennifer Ruttkay
6950 N East Prairie Rd
Lincolnwood, IL 60712-2554

Dear Jennifer:

On behalf of everyone at Renaissance, we want to thank you for choosing us to be a valued partner in education. We are writing today to let you know that it's almost time to renew your subscription:

Product Expiring 6/30/2023

FastBridge

Now, more than ever, we know how important it is for schools to have the right set of teaching tools that work together to provide continuous learning for all students. Renaissance is here to help you and your students continue learning and growing—both inside and outside of the classroom.

You should have received an email recently with your renewal notification and details for renewing. Or, feel free to contact me to discuss your subscription options.

Thank you again for choosing Renaissance to help accelerate learning for all. Our entire team is dedicated to assisting you and ensuring the renewal process is convenient and easy to complete. If you need assistance or have any questions about your renewal, please reach out to me and I will be happy to assist.

Sincerely,

Mallory Hartnett

Account Mgr I

(847)957-4960

Mallory.Hartnett@renaissance.com

P.S. Interested in learning more about the just-right tools for remote learning? When students can use the same digital solutions from home that they use inside the classroom, you can ensure continuous learning for all. Visit <https://www.renaissance.com/> to see more about how Renaissance's suite of products can help.

PO Box 8036, Wisconsin Rapids, WI 54495-8036
 Phone:(800) 338-4204 | Fax:(877) 280-7642
 Federal I.D. 39-1559474
www.renaissance.com

Lincolnwood School District 74 - 180155
 6950 N East Prairie Rd
 Lincolnwood, IL 60712-2554
 Contact: Ms. Jennifer Ruttkay - (847) 675-8234
 Email: jruttkey@sd74.org

Subscription End: 6/30/2023
Notice Date: 03 2023
Reference ID: 645548

Quote Summary	
School Count: 1	
Renaissance Products & Services Total	\$7,812.48
Applied Discounts	\$(732.42)
Sales Tax	\$0.00
Grand Total	USD \$7,080.06

Pricing and discounts are subject to change if alterations are made to this quote.
 To receive applicable discounts, all orders included on this quote must be received at the same time.

By signing below, Customer:

- acknowledges that the Person signing this Quote is authorized to do so;
- agrees that this Quote, any other quotes issued to Customer during the Subscription Period and Customer and its Authorized Users access to and use of the Products and Services are subject to the Renaissance Terms of Service and License located at <https://doc.renlearn.com/KMNet/R62416.pdf> which are incorporated herein by reference;
- acknowledges receipt of the Notice of Renaissance's Practices Relating to Children's Online Privacy <https://docs.renaissance.com/R63870> directed to you as the school official responsible for authorizing the use of the Renaissance Products and Services in the educational context; and,
- consents on behalf of parents/legal guardians to the collection, use, and disclosure of the personal information of children under the age of 13 with respect to use of the Renaissance Products and Services, as described in Renaissance's Children's Online Privacy Notice <https://docs.renaissance.com/R63871>

To accept this offer and place an order, please sign and return this Quote.

Renaissance will issue an invoice pursuant to this Quote on the Invoice Date you specify below. If no Invoice Date is listed, Renaissance will issue an invoice within 30 days from the date of this Quote. If your organization requires a purchase order prior to invoicing, please check the box below and issue your purchase order to the Renaissance address below no later than 15 days prior to the Invoice Date. Payment is due net 30 days from the Invoice Date.

If your billing address is different from the address at the top of this Quote, please add that billing address below.

Please check here if your organization requires a purchase order prior to invoicing: []

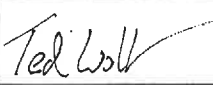
Renaissance Learning, Inc.	Lincolnwood School District 74 - 180155
	By:
Name: Ted Wolf	Name:
Title: VP - Corporate Controller	Title:
Date: 03/03/2023	Date:
	Invoice Date:

Mail: PO Box 8036, Wisconsin Rapids, WI 54495-8036
Fax: (877)280-7642
Email: electronicorders@renaissance.com

PO Box 8036, Wisconsin Rapids, WI 54495-8036
Phone:(800) 338-4204 | Fax:(877) 280-7642
Federal I.D. 39-1559474
www.renaissance.com

Phone: (877)444-3172

*This quote is valid for 30 days. It may have been previously sent with a different reference number, and may reflect changes made in the past 30 days. Alterations to this quote will not be honored without Renaissance Learning approval. Tax has been estimated and is subject to change without notice. Unless you provide Renaissance with a valid and correct tax exemption certificate applicable to your purchase of product and the product ship-to location, you are responsible for sales and other taxes associated with this order. Standard payment terms are net 30 days from invoice date.

PO Box 8036, Wisconsin Rapids, WI 54495-8036
 Phone:(800) 338-4204 | Fax:(877) 280-7642
 Federal I.D. 39-1559474
www.renaissance.com

Renewal Details				
Applications				
Products & Services	Subscription Period	Quantity	Unit Price	Total
FastBridge Subscription	07/01/2023 - 06/30/2024	939	\$8.32	\$7,812.48
Applications Subtotal				\$7,812.48
Applied Discounts				\$(732.42)
Applications Total				USD \$7,080.06

PO Box 8036, Wisconsin Rapids, WI 54495-8036
Phone:(800) 338-4204 | Fax:(877) 280-7642
Federal I.D. 39-1559474
www.renaissance.com

Renewal Subscription Summary	
FastBridge Subscription Total	Quantity
Lincolnwood School District 74 - 180155	939
FastBridge Subscription Total	939

Lexile is a registered trademark of MetaMetrics, Inc.

©Copyright 2023 Renaissance Learning, Inc. All rights reserved.

All logos, designs, and brand names for Renaissance's products and services are trademarks of Renaissance Learning, Inc., and its subsidiaries, registered, common law, or pending registration in the United States.

All other product and company names should be considered the property of their respective companies and organizations.

PO Box 8036, Wisconsin Rapids, WI 54495-8036
 Phone: (800) 338-4204 | Fax: (877) 280-7642
 Federal I.D. 39-1559474
www.renaissance.com

Quote #: RPRNQ2935450

Lincolnwood School District 74 - 180155
 6950 N East Prairie Rd
 Lincolnwood, IL 60712-2554
 Contact: Jennifer Ruttkay - (847) 675-8234
 Email: jruttkay@sd74.org

Reference ID: 645548

Subscription Ends:
6/30/2023

Quote Summary

School Count: 1

Renaissance Products & Services Total	\$7,812.48
Applied Discounts	\$(732.42)
Shipping and Processing	\$0.00
Sales Tax	\$0.00
Grand Total	USD \$7,080.06

This quote includes: FastBridge.

By signing below, Customer:

- acknowledges that the Person signing this Quote is authorized to do so;
- agrees that this Quote, any other quotes issued to Customer during the Subscription Period and Customer and its Authorized Users access to and use of the Products and Services are subject to the Renaissance Terms of Service and License located at <https://doc.renlearn.com/KMNet/R62416.pdf> which are incorporated herein by reference;
- acknowledges receipt of the Notice of Renaissance's Practices Relating to Children's Online Privacy <https://docs.renaissance.com/R63870> directed to you as the school official responsible for authorizing the use of the Renaissance Products and Services in the educational context; and,
- consents on behalf of parents/legal guardians to the collection, use, and disclosure of the personal information of children under the age of 13 with respect to use of the Renaissance Products and Services, as described in Renaissance's Children's Online Privacy Notice <https://docs.renaissance.com/R63871>

To accept this offer and place an order, [please sign and return this Quote](#).

Renaissance will issue an invoice for this Quote on the earlier of (a) the date You specify below or (b) the day before Your Subscription Period starts (Invoice Date). If You require a purchase order, You agree to provide one to Renaissance at least 15 days before the Invoice Date. You also agree to pay the invoice within 30 days of the Invoice Date.

Please check here if your organization requires a purchase order prior to invoicing: []

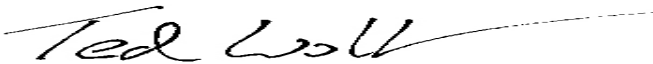
Renaissance Learning, Inc.	Lincolnwood School District 74 - 180155
	By:
Name: Ted Wolf	Name:
Title: VP - Corporate Controller	Title:
Date: 5/3/2023	Date:
	Invoice Date:

Email: electronicorders@renaissance.com

If your billing address is different from the address at the top of this Quote, please add that billing address below.

Bill To:

If changes are necessary, or additional information is required, please contact your account executive at (800) 338-4204, Thank You.

PO Box 8036, Wisconsin Rapids, WI 54495-8036
Phone: (800) 338-4204 | Fax: (877) 280-7642
Federal I.D. 39-1559474
www.renaissance.com

Quote #: RPRNQ2935450

All quotes and orders are subject to availability of merchandise. This Quote is valid for 60 days from the date under Renaissance's signature. Professional development expires one year from purchase date. Alterations to this quote will not be honored without Renaissance approval. Please note: Any pricing or discount indicated is subject to change with alterations to the quote. Tax has been estimated and is subject to change without notice. Unless you provide Renaissance with a valid and correct tax exemption certificate applicable to your purchase of product and the product ship-to location, you are responsible for sales and other taxes associated with this order.

United States government and agency transactions into Arizona: The Tax or AZ-TPT item(s) listed on this quote and subsequent invoice(s) is a charge to recover the cost of the Arizona Transaction Privilege Tax (TPT). The incidence of the TPT is on Renaissance Learning for the privilege of conducting business in the State of Arizona. Since the tax is not directly imposed on the United States, the constitutional immunity of the United States does not apply.

Hawaii residents only: Orders shipped to Hawaii residents will be subject to the 4.166% (4.712% O'ahu Is.) Hawaii General Excise tax. United States government and agency transactions into Hawaii: The Tax or General Excise Tax item(s) listed on this quote and subsequent invoice(s) is a charge to recover the cost of the Hawaii General Excise Tax. The incidence of the General Excise Tax is on Renaissance Learning for the privilege of conducting business in the State of Hawaii. Since the tax is not directly imposed on the United States, the constitutional immunity of the United States does not apply.

New Mexico residents only: Orders shipped to New Mexico residents will be subject to the 5.125% (Location Code: 88-888) Gross Receipts tax. United States government and agency transactions into New Mexico: The Tax or Gross Receipts Tax item(s) listed on this quote and subsequent invoice(s) is a charge to recover the cost of the New Mexico Gross Receipts Tax. The incidence of the Gross Receipts Tax is on Renaissance Learning for the privilege of conducting business in the State of New Mexico. Since the tax is not directly imposed on the United States, the constitutional immunity of the United States does not apply. Starting July 1, 2021 New Mexico requires sellers to collect tax on the state and local rate. This varies depending on the city and county.

Students can become their most amazing selves – only when teachers truly shine. Renaissance amplifies teachers' effectiveness in the classroom – transforming data into actionable insights to improve learning outcomes. Remember, we're here to ensure your successful implementation. Please allow 30-90 days for installation and set-up.

PO Box 8036, Wisconsin Rapids, WI 54495-8036
 Phone: (800) 338-4204 | Fax: (877) 280-7642
 Federal I.D. 39-1559474
www.renaissance.com

Quote #: RPRNQ2935450

Quote Details				
Lincolnwood School District 74 - 180155				
Products & Services	Subscription Period	Quantity	Unit Price	Total
Applications				
FastBridge Subscription	07/01/2023 - 06/30/2024	939	\$8.32	\$7,812.48
Professional Services				
Renaissance Smart Start Product Training (included with purchase)		1	\$0.00	\$0.00
Lincolnwood School District 74 Subtotal				\$7,812.48
			Applied Discounts	\$(732.42)
Lincolnwood School District 74 Total				USD \$7,080.06

Lexile is a registered trademark of MetaMetrics, Inc.

©Copyright 2023 Renaissance Learning, Inc. All rights reserved.

All logos, designs, and brand names for Renaissance's products and services are trademarks of Renaissance Learning, Inc., and its subsidiaries, registered, common law, or pending registration in the United States. All other product and company names should be considered the property of their respective companies and organizations.

AMENDMENT TO AGREEMENT BETWEEN THE BOARD OF EDUCATION OF LINCOLNWOOD SCHOOL DISTRICT 74 AND RENAISSANCE LEARNING, INC.

This Amendment is entered into as of June 1, 2023, by and between the Board of Education of Lincolnwood School District No. 74 (“School District”) and Renaissance Learning, Inc. (“Renaissance”) pursuant to Quote # RPRNQ2935450*, and the Renaissance Terms of Service and License (collectively, the “Agreement”), and shall continue in force for any extensions of the Agreement or subsequent renewals or order forms, unless otherwise agreed by the Parties.

1. **Terms and Conditions.** This Amendment modifies the Agreement entered into by the Parties. Terms and conditions not amended herein shall have the same meaning as in the Agreement. If there is conflict between this Amendment and the Agreement, the terms of this Amendment will prevail. Renaissance shall not materially modify or amend the Agreement (see www.renaissance.com) during the term of this Agreement or any extension thereof, without providing written notice.
2. **Auto-Renewal.** The term of the Agreement between the parties shall not automatically renew. Subsequent extensions of the Agreement shall require notice to and approval of the School District.
3. **FOIA/OMA.** School District shall not be required to make any claim of privilege that may be applicable to prevent disclosure in response to, and will not be required to notify Renaissance prior to any disclosure in response to, a valid FOIA request for information that is not confidential or proprietary. Renaissance acknowledges and agrees that the Agreement is not confidential or exempt from disclosure under the Illinois Freedom of Information Act or Open Meetings Act.
4. **Governing Law/Venue.** This Agreement will be governed and construed in accordance with the laws of the State of Illinois, without regard to any conflicts of law provisions. Venue for all actions between the parties shall lie solely in the Circuit Court of Cook County, Illinois. Renaissance hereby agrees to this exclusive venue, to personal jurisdiction of this court, and to service of process in accordance with its rules of civil procedure, and Renaissance waives any objection that this venue is not convenient. Any references to binding arbitration, the waiver of the right to a jury trial, or the waiver of claims which may be litigated on a class or representative basis shall be deleted from the Agreement as it currently exists or as it may be modified or amended in the future.
5. **Illinois Student Privacy Laws.** In addition to its obligation to maintain student data in accordance with applicable federal laws, Renaissance shall also maintain all student data obtained from School District in accordance with any applicable Illinois laws, including (without limitation, and only to the extent applicable) the *Illinois School Student Records Act* (105 ILCS 10/1 *et seq.*); and the *Illinois Student Online Personal Protection Act* (105 ILCS 85/1 *et seq.*) (herein “SOPPA”). In accordance with SOPPA, the School District and Renaissance have separately executed a “Standard Student Data Privacy Agreement” IL-NDPA.

6. **Insurance.** During the term of this Agreement and any renewal thereof, Renaissance shall maintain a cyber-liability insurance policy insuring against data breaches. School District shall be named as an additional insured on such policy. Any damages limitations in this Agreement shall not apply to School District in its capacity as an additional insured.

7. **Authority to Execute.** Each signatory hereto represents and warrants that he or she has the proper corporate authority to execute this Amendment and bind his or her entity to the terms and conditions hereof.

WHEREAS, this Amendment and its terms and conditions are agreed upon by the Parties on the date set forth above.

**BOARD OF EDUCATION OF
LINCOLNWOOD SCHOOL DISTRICT 74**

RENAISSANCE LEARNING, INC.

By: _____

By: Ted Wolf

Its: _____

Its: VP, Global Controller

Date: _____

Date: May 4, 2023

RENAISSANCE®

Terms of Service and License Renaissance Learning, Inc.

These Terms of Service state the binding legal terms and conditions between Customer and Renaissance that govern the Products and Services that Customer has contracted to receive pursuant to a Quote signed by Customer and Renaissance.

1. **Definitions.** As used above and in these Terms of Service, capitalized words have the meaning set forth in Exhibit A or as otherwise expressly defined in these Terms of Service.
2. **License and Access to Products.**
 - a. **License.** Subject to the terms and conditions set forth in these Terms of Service, Renaissance grants Customer a limited, revocable, non-exclusive, non-transferable, non-sublicensable license during the Term solely to access and use the Products for educational assessment and practice functions. No other license, express or implied, is granted by these Terms of Service.
 - b. **Access and Use Limitations.**
 - i. **Access and Use.** Customer may access and use the Products during the period beginning on the first day of the Subscription Period and ending upon the earlier of expiration of the Subscription Period or termination of the Agreement. Access may be restricted during Renaissance's maintenance and updating of the Products.
 - ii. **Quantity.** The Quote sets forth a quantity for each identified Product or Service. Customer may not exceed the quantities stated in the Quote without further written agreement by the parties.
 - iii. **Access and Use Restrictions.** Customer shall not access or use the Products for any purpose beyond the limited license granted in these Terms of Service. Without limiting the foregoing, Customer shall not: (A) copy, modify, or create derivative works of the Products, in whole or in part; (B) rent, lease, lend, sell, sublicense, assign, distribute, publish, transfer, or otherwise make available the Products; (C) reverse engineer, disassemble, decompile, decode, adapt, or otherwise attempt to derive or gain access to the source code of the Products, in whole or in part; (D) remove any proprietary notices from the Products; (E) allow anyone other than Customer or its Authorized Users to access or use the Products; (F) use the Products in any manner or for any purpose that infringes, misappropriates, or otherwise violates any Intellectual Property Rights or other right of any Person, or that violates any applicable law; (G) access or use the Products for any purpose not authorized under these Terms of Service; (H) share, transfer or sell Valid Login Information to anyone other than Authorized Users, and shall be responsible for any access to, or use of, the Products resulting from Customer's failure to safeguard Valid Login Information; or (I) allow multiple Persons to access or use the Products in a manner intended to avoid incurring fees. Customer agrees to promptly notify Renaissance of any actual or suspected unauthorized access to or use of the Products, after which Renaissance may then implement a Service Suspension.
 - iv. **Authorized Users.** Customer may permit its Authorized Users to access and use the Products in the same manner and for the same purposes as Customer, as set forth in these Terms of Service. Customer shall be responsible and liable for all access to and use of the Products by any Authorized User and any other access to the Products permitted or enabled by Customer or an Authorized User.
 - v. **Suspension.** Notwithstanding anything to the contrary in these Terms of Service, Renaissance may suspend access and use for any portion or all of the Products by a Customer or Authorized User if Renaissance determines in good faith that: (A) Customer or an Authorized User's access to or use of the Products and systems disrupts or poses a risk to the security or integrity of any of Renaissance's Products or systems, or any of its customers or vendors; (B) Customer or an Authorized User are accessing or using the Products or systems for fraudulent or illegal activities; (C) any vendor or supplier of Renaissance has suspended or terminated Renaissance's access to or use of any third-party product or service necessary to the Products; or (D) Customer has not timely paid any Fees (any such suspension described in subclause (A), (B), (C), or (D) a "Service Suspension"). Renaissance shall use reasonable efforts to provide written notice of any Service Suspension to Customer and to provide updates regarding resumption of access to the Products following any Service Suspension, which shall be in Renaissance's sole discretion. Renaissance shall use reasonable efforts to resume providing access to the Products as soon as reasonably possible after the event giving rise to the Service Suspension is cured. Renaissance will have no liability for any damages, liabilities, losses, or any other consequences of a Service Suspension.
 - vi. **Customer Hardware, Other Software and Services.** Renaissance does not bear any responsibility or liability for any Third-Party Services and does not guarantee that any Third-Party Services will operate correctly or that they are compatible or interoperable with the Products.
3. **Services.** Renaissance shall provide the Services identified in the Quote and any Statement of Work agreed to by the parties in writing. All Services identified in the Quote or any applicable Statement of Work shall be governed by these Terms of Service, including, without limitation, Exhibit B.

4. **Payment Obligations.**

- a. **Fees.** Customer shall pay Renaissance all amounts listed in the Quote ("Fees") within 30 days of invoice. Customer may not withhold or setoff any amounts due under the Agreement. Renaissance may charge interest from the time payment was due until the time paid at the higher rate of (A) 1% per month compounded monthly, or (B) the highest rate allowed by law in Customer's state. Customer agrees that any of Renaissance's Affiliates may issue invoices for amounts owed under the Agreement. Amounts paid for Products and Services are not refundable, regardless of the extent they are utilized.
- b. **FastBridge True-up.** FastBridge subscriptions are based on per student, per school year fees. The initial fee to activate a subscription is based on the estimate by Customer of the number of unique students that will have score data entered. Renaissance will run reconciliation reports in or about May of each Subscription Period and invoice Customer for the actual number of unique students in excess of the estimate reflected in the Quote.

5. **Term; Termination; Effect of Termination.**

- a. **Term.** The term of the Agreement starts on the earlier of (i) the date that the Customer signs the Quote or (ii) the first date of the Subscription Period and continues until the end of the last Subscription Period listed in the Quote (the "Term"), except as set forth in a further written agreement of the parties.
- b. **Termination.**
 - i. Either party may terminate the Agreement upon written notice if the other party does not cure a material breach within 30 days of written notice of the breach from the other party describing the breach and stating the intent to terminate.
 - ii. Renaissance may terminate Customer's access to the Products and the Agreement if Customer fails to pay any amount due within 10 business days of written late notice from Renaissance.
- c. **Effect of Expiration or Termination.** Upon expiration or termination of the Agreement:
 - i. all rights and licenses to use and access the Products granted to Customer under the Agreement immediately terminate, and Customer shall cease all access to, and use of, the Products provided to Customer under the Agreement, except that (A) Customer may continue to access the Products for the limited purpose of retrieving Customer Data, during the period set forth in the Data Protection Addendum, and (B) Customer and Authorized Users may continue to access and use the free version of any Premium Hybrid Products that Customer had purchased, provided that these Terms of Service shall govern Customer's continuing access and use of the free version of any Premium Hybrid Products;
 - ii. Customer shall return or destroy, at Renaissance's sole discretion, all Confidential Information of Renaissance. Customer shall also be responsible for retrieving Customer Data from the Products, as described in the Data Protection Addendum.
 - iii. each party shall cease the use of the other party's Intellectual Property Rights; and
 - iv. Customer shall pay Renaissance all amounts due under the Agreement upon the earlier of their due dates or 30 days after the effective date of termination.
- d. **Survival.** Notwithstanding anything to the contrary in the Agreement, all accrued payment obligations under the Agreement, any remedies for breach of the Agreement, Sections 5(c), and 6-11, and any provisions that are required by law to survive, shall survive expiration or termination of the Agreement. Further, the Data Protection Addendum and the applicable provisions of these Terms of Service shall survive expiration or termination of the Agreement to the extent that the Data Protection Addendum provides Customer limited access to the Products for the purpose of retrieving Customer Data.

6. **Intellectual Property.** Notwithstanding the limited license granted under these Terms of Service,

- a. **No Transfer of Rights.** As between Renaissance and Customer, Renaissance owns all Intellectual Property Rights in or embodied by the Products. Except for the license set forth in Section 2 above, neither Customer nor its Authorized Users will obtain, pursuant to or by virtue of these Terms of Service or their use or access to the Products or the Services, any Intellectual Property Rights in the Products or the Services.
- b. **Customer License to Renaissance.** Customer grants to Renaissance and its Affiliates a worldwide, perpetual, irrevocable, royalty-free license to use, distribute, disclose, and make and incorporate into the Products any suggestion, enhancement request, recommendation, correction or other feedback provided by Customer or its Authorized Users relating to the operation of the Products.

7. **Confidentiality.** Recipient may use Confidential Information provided to it by or on behalf of the other party (the "Disclosed Information") only as necessary to perform its obligations or exercise its rights pursuant to this Agreement. Recipient may not disclose the Disclosed Information to any other person or entity except its Affiliate, employee, director, shareholder, member, agent or contractor (each a "Recipient Representative") for purposes of performing Recipient's obligations or exercising Recipient's rights under this Agreement, shall require that each of its Recipient Representatives comply with all obligations of Recipient under this Section 7, and will be liable for any breach of this Section 7 by its Recipient Representative. Recipient shall treat the Disclosed Information with the same level of care that it holds its own Confidential Information. In addition to disclosure to Recipient Representatives as set forth above, Recipient may disclose Disclosed Information to the extent compelled by law, provided Recipient gives the other party prompt prior written notice of the compelled disclosure to the extent legally permitted to permit the other party to seek a protective order, and if disclosed to a government agency seek confidentiality protection if available under applicable laws and regulations. Recipient acquires no licenses or other rights to the Disclosed Information except as otherwise set forth in the

Agreement. Notwithstanding anything to the contrary above, Customer PII is governed by the Data Protection Addendum and not this Section 7.

8. **Data.**

- a. Customer PII. Renaissance shall comply with its privacy and security obligations for Customer PII as set forth in the Data Protection Addendum.
- b. Data Ownership and License. As between Renaissance and Customer, Customer owns the Customer Data. Customer grants Renaissance a non-exclusive, royalty-free, worldwide license to use the Customer Data throughout the Term to perform under the Agreement and as further described in the Data Protection Addendum. As between Renaissance and Customer, Renaissance owns the Renaissance Data. Renaissance Data is not subject to the use or disclosure restrictions of this Agreement that apply to Customer Data.
- c. Prohibited Data. Customer acknowledges and agrees that the Products are intended for academic, educational and assessment purposes. Customer shall not provide to Renaissance any non-academic or non-educational related data such as social security numbers, protected health information, driver's license information, passport or visa numbers, credit card or other financial account numbers, and Renaissance has no obligation to monitor for entry of such data.

9. **Indemnification.**

- a. Renaissance Indemnification. Renaissance shall defend and indemnify Customer and its directors, officers, shareholders, members, employees, agents and representatives against any third-party Claim (including reasonable attorneys' fees) alleging that Customer's use of the Products or Services infringes Intellectual Property Rights, except that Renaissance is not responsible for any third-party Claim arising from: (i) modification of Products or Services by, or directed by, Customer, an Authorized User, or a Person who gained access to the Products or Services through the act or omission of Customer or an Authorized User; (ii) any Third-Party Service; or (iii) Customer's use of the Products or Services in violation of or for purposes not contemplated by the Agreement. If Renaissance has reason to believe that any of its Products or Services may infringe a third party's Intellectual Property Rights, Renaissance may, at its sole expense and option: (i) negotiate a license for Customer's continued access to and use of the Products or Services; (ii) replace or modify the Products or Services with non-infringing Products; or (iii) terminate Customer's access to the Products or Services. The indemnity provided in this section shall be Customer's sole and exclusive remedy regarding third-party Claims arising from infringement of Intellectual Property Rights.
- b. Customer Indemnification. Customer shall defend and indemnify Renaissance, its Affiliates, and the directors, officers, shareholders, members employees, agents and representatives of each of the foregoing, against all Claims (including reasonable attorneys' fees) brought against or incurred by Renaissance: (i) alleging that the combination of a Third-Party Service or configuration provided by Customer when used with the Products, infringes or misappropriates a third party's Intellectual Property Rights, or arising from (ii) Customer's use of the Products in an unlawful manner or in violation of the Agreement, (iii) Customer's use of a Third-Party Service (iv) any breach of Customer's obligations under the Agreement; or (v) the negligence or intentional misconduct of Customer or its Authorized Users, employees contractors, agents or representatives.
- c. Indemnification Procedure. As a condition of the defense and indemnification obligations under Section 9.a or 9.b (as applicable), each party agrees to: (i) promptly notify the other in writing of any third-party Claim for which a party seeks defense or indemnification under these Terms of Service; (ii) provide the defending or indemnifying party sole control of the defense of the Claim; (iii) cooperate at the defending or indemnifying party's expense with reasonable requests in support of the defense Claim; and (iv) refrain from agreeing to or acknowledging liability for the Claim.

10. **Warranties and Liabilities.**

- a. WARRANTIES. RENAISSANCE PROVIDES THE PRODUCTS AND SERVICES "AS IS". RENAISSANCE MAKES NO WARRANTY OR OTHER PROMISE THAT THE PRODUCTS WILL BE UNINTERRUPTED, SECURE, OR ERROR FREE, OR THAT POSSIBLE DEFECTS WILL BE CORRECTED. RENAISSANCE SPECIFICALLY DISCLAIMS ANY REPRESENTATIONS OR WARRANTIES, EXPRESS, IMPLIED, OR STATUTORY, REGARDING THE PRODUCTS OR SERVICES, INCLUDING WITHOUT LIMITATION TO ANY IMPLIED WARRANTY OF MERCHANTABILITY, FITNESS FOR A PARTICULAR PURPOSE, GUARANTEED OUTCOME, RESULT OR SUCCESS, OR NON-INFRINGEMENT OR TITLE, OR ANY WARRANTY OR PROMISE ARISING FROM COURSE OF DEALING, USAGE OR PERFORMANCE.
- b. CONSEQUENTIAL, SPECIAL AND SIMILAR DAMAGES. IN NO EVENT WILL EITHER PARTY OR ITS AFFILIATES HAVE ANY LIABILITY ARISING OUT OF OR RELATED TO THE AGREEMENT FOR ANY LOST PROFITS, REVENUES, GOODWILL, OR INDIRECT, SPECIAL, INCIDENTAL, CONSEQUENTIAL, COVER, BUSINESS INTERRUPTION OR PUNITIVE DAMAGES, WHETHER AN ACTION IS IN CONTRACT OR TORT AND REGARDLESS OF THE THEORY OF LIABILITY EXCEPT AS TO DAMAGES INDEMNIFIED UNDER SECTION 9, EVEN IF A PARTY OR ITS AFFILIATES HAVE BEEN ADVISED OF THE POSSIBILITY OF SUCH DAMAGES OR IF A PARTY'S OR ITS AFFILIATES' REMEDY OTHERWISE FAILS OF ITS ESSENTIAL PURPOSE. THE FOREGOING DISCLAIMER WILL NOT APPLY TO THE EXTENT PROHIBITED BY LAW.
- c. OTHER LIMITS. RENAISSANCE'S LIABILITY UNDER THESE TERMS OF SERVICE: (I) WILL BE LIMITED TO DIRECT DAMAGES, AND DOES NOT INCLUDE ANY INDIRECT, CONSEQUENTIAL, SPECIAL, EXEMPLARY, PUNITIVE OR SIMILAR DAMAGES; AND (II) WILL NOT EXCEED THE LESSER OF (A) THE FEES, OR (B) \$100,000 AND (C) WITH RESPECT TO SERVICES OR DELIVERABLES, WILL

BE LIMITED TO CORRECTION OF SUCH SERVICES OR DELIVERABLES. IF CORRECTION IS IMPRACTICAL, RENAISSANCE WILL REFUND THE FEES RELATED TO NON-CORRECTABLE SERVICES OR DELIVERABLES ON A *PRO RATA* BASIS.

11. **Miscellaneous.**

- a. **Compliance with Applicable Laws.** Renaissance shall comply with the laws governing it as a provider of the Products and Services. Customer shall comply with the laws governing it as an educational organization or entity or its usage of the Products and Services.
- b. **Entire Agreement.** The Agreement, notwithstanding anything to the contrary in any purchase order, constitutes the entire agreement between the parties with respect to its subject matter and supersedes all other agreements or communications, whether written or oral. Any amendments or other changes to the Agreement must be made in writing and signed by both parties.
- c. **Severability.** If a provision of these Terms of Service is held to be invalid or unenforceable, the remaining provisions shall continue to be valid and enforceable as if such provision had not been set forth in these Terms of Service. Both parties agree to substitute a valid provision most closely approximating the intent of the severed provision.
- d. **Waiver.** No waiver by a party of a right or obligation under the Agreement is binding unless it is stated in writing to the other party. Failure of a party to enforce a breach of an obligation of another party under the Agreement does not limit that party's right to enforce a subsequent or different breach of that obligation.
- e. **Dispute Resolution.** Before prosecuting a Claim, the party asserting the Claim must provide the other party written notice of the Claim and not file a Claim until 60 days after that notice is delivered. During those 60 days, the parties each shall make a good faith effort to resolve the dispute. This sub-Section does not apply to or limit either party's right to seek equitable relief, or Renaissance's right to suspend or terminate Customer's access to or use of the Products under these Terms of Service.
- f. **Limitation of Action.** Any Claim by Customer must be brought within two years after the cause of action arose or such shorter period of time as required by applicable law.
- g. **Governing Law.** For United States-based Customers, the Agreement and all disputes or Claims arising under them are governed and shall be decided under the laws of the state, commonwealth or territory in which Customer resides based on the address set forth in the Quote, without regard to that state's, commonwealth's or territory's choice of law rules. For Customers based outside of the United States, all disputes or Claims arising under the Agreement shall be governed and decided under the laws of the State of Wisconsin.
- h. **Notices.** Notices under the Agreement shall be in writing and shall be deemed effective when delivered to the addresses set forth in the Quote (i) in-person, (ii) via the USPS, certified or registered mail, (iii) via reputable courier, addressed to the addresses set forth in the Quote, or (iv) via e-mail, in the case of notice to Renaissance at legal@renaissance.com, and in the case of notice to Customer, to Renaissance's address of record for Customer.
- i. **Assignment.** The Agreement may be assigned only with the prior written consent of the other party which shall not be unreasonably withheld or delayed, except that Renaissance reserves the right to assign the Agreement without restriction to an Affiliate or in connection with a merger, acquisition, corporate reorganization, or sale of all or substantially all of its or an Affiliate's assets. Upon valid transfer, the Agreement inures to the benefit of, and binds, the successors and assigns of the parties. Any assignment in violation of this Section 11(i) is invalid.
- j. **Relationship of the Parties.** The parties are independent contractors, having no other business affiliation. Neither party may assume or create any obligation or make any representation or warranty on behalf of the other party. There are no third-party beneficiaries to the Agreement.
- k. **Anti-Corruption.** Customer represents that it has not received or been offered any bribe, kickback or payment, or any gift or thing of value from Renaissance or its employees or agents that violates any law or policy applicable to Customer. Both parties agree to comply with all anti-corruption laws applicable to it.
- l. **Duplicates.** The Agreement may be signed separately by the parties and the signature pages combined to create an original. Authorized electronic signatures are valid. Digitized copies of an original copy of the Agreement shall be treated as an original for all purposes.
- m. **Compliance with Export and Sanction Laws and Regulations.** The Products and Services may be subject to export laws and regulations of the United States and other jurisdictions. Renaissance and Customer each represent that it is not on any U.S. government denied-party list. Customer shall not permit Authorized User access to any Products or Services in violation of any U.S. export or sanction law or regulation.
- n. **Representations.** Each party represents and warrants that it is duly authorized to enter into the Agreement.
- o. **Equitable Rights.** Each party acknowledges that a breach or threatened breach of Section 6 (Intellectual Property) or Section 7 (Confidentiality) may cause the non-breaching party irreparable damage, entitling it to seek equitable relief, in addition to any other remedy.
- p. **Force Majeure.** Except for the obligation to make payments, neither party will be liable for any failure or delay in its performance under the Agreement due to any cause beyond its reasonable control, including, without limitation, acts of war or terrorism, acts of God, earthquake, flood, pandemic, embargo, labor shortage, governmental act or failure of the Internet (not resulting from the actions or inactions of Renaissance); provided that the delayed party (i) gives the other party prompt notice of such cause, (ii)

uses its reasonable commercial efforts to promptly correct such failure or delay in performance, and (iii) will; not be considered in breach during the duration of the Force Majeure Event. In the event a Force Majeure Event continues for a period of 90 calendar days, either party may elect to terminate the Agreement upon notice to the other party.

EXHIBIT A

Definitions

"Affiliate" of an entity means any entity controlling, controlled by or under common control with that entity. For the purposes of this definition, "control" means the possession, directly or indirectly, of the power to direct the management and policies of an entity through the ownership of voting securities or other equity.

"Agreement" means these Terms of Service together with any Quote or Statement of Work agreed to by the parties to which these Terms of Service are attached or into which these Terms of Service are incorporated by reference, together with any amendments, modifications, or renewals of such Quote or Statement of Work agreed by the parties in writing.

"Authorized User" means Customer's faculty, staff, administrators, teachers, and students accounted for in the Quote and, if applicable, the parents or legal guardians of those students, in each case who are authorized by Customer to access and use the Products under the strictly limited rights granted to Customer pursuant to the Agreement.

"Claim" means any lawsuit, administrative proceeding, arbitration, or other legal claim for relief.

"Confidential Information" means all technical and non-technical information, including without limitation patent, copyright, trade secret, and proprietary information, techniques, sketches, drawings, models, inventions, know-how, processes, apparatus, equipment, software programs and software source documents related to the current, future and proposed products and services of each of the parties, and includes without limitation, each party's respective information concerning research, experimental work, development, design details and specifications, engineering, financial information, business forecasts and marketing plans and information. Confidential Information does not include any information that (i) is or becomes generally known to the public without breach of any obligation owed to the disclosing party, (ii) was known to the receiving party prior to its disclosure by the disclosing party without breach of any obligation owed to the disclosing party, (iii) is received from a third party without knowledge of any breach of any obligation owed to the disclosing party, or (iv) was independently developed by the receiving party.

"Content" means all types of information including, without limitation, books, articles, recordings, documentation, photographs, graphics, video, databases or any other compilations rendered available by Renaissance or accessible through the Products, as well as all related Intellectual Property Rights. For the avoidance of doubt, Content includes all original expressions in any media, as well as any derivations of such original expressions.

"Customer" means the school, school district, educational institution or other organization that signed the Quote.

"Customer Data" means: (i) data provided by the Customer in connection with the Products; and (ii) data generated by Authorized Users' use of the Products that is associated with an individual person. The categories of data collected by Products are described in the Categories of Data Collected by Product available at <https://doc.renlearn.com/KMNet/R62941.pdf>. For the avoidance of doubt, Customer Data does not include Deidentified Data or system performance, transactional, or other similar statistics or analytics.

"Data Protection Addendum" means Exhibit D to these Terms of Service and applies to PII based on the location of the applicable individual as set forth in the Data Protection Addendum. Renaissance reserves the right to update Exhibit D in its sole discretion.

"Deidentified Data" means Customer Data that has had any PII removed to such a degree that there is no reasonable basis to believe that the remaining data can be used to identify an individual.

"Deliverables" means any work product or materials to be developed or delivered by Renaissance in connection with the Products or Services, as well as all related Intellectual Property Rights.

"Intellectual Property Rights" means patents, patent rights, patent applications, and continuing (continuation, divisional, or continuation-in-part) applications, re-issues, extensions, renewals, and re-examinations of patents; registered and unregistered trademarks and service marks, trademark and service mark rights, trade names, and domain names; registered and unregistered copyrights; trade secrets and inventions, whether patentable or unpatentable; all other intellectual, industrial, or proprietary rights as now existing or that come into existence; and pending applications for and registrations of any of the foregoing; whether arising under the laws of the United States or laws of any other state, country, or jurisdiction in the world.

"Person" means a person, entity or organization.

"Personally Identifiable Information or PII" is defined in the Data Protection Addendum.

"Premium Hybrid Products" means the paid and free versions of the educational online software products (including, without limitation, all related Intellectual Property Rights, Deliverables and Content) listed on Exhibit C, access to which is being provided to Customer under the Agreement. Renaissance reserves the right to update Exhibit C in its sole discretion.

"Products" means the Premium Hybrid Products and other educational online software products identified in the Quote (including, without limitation, all related Intellectual Property Rights, Deliverables and Content) distributed by Renaissance or one of its Affiliates.

"Quote" means that certain document identified as a sales quote, provided by Renaissance to Customer and accepted by Customer, setting forth certain Products or Services being obtained by Customer from Renaissance for a specified Subscription Period, as well as such other business terms to which the parties agree to be bound, and which expressly incorporates these Terms of Services.

"Recipient" means a party or its Affiliate that receives Confidential Information of the other party.

"Renaissance" means Renaissance Learning, Inc., a Wisconsin corporation.

"Renaissance Data" means the Deidentified Data and the performance, system and operational data created by Renaissance.

"Services" means those professional services identified in the Quote and any other professional, technical or support services that Renaissance provides to Customer as set forth in a Quote or Statement of Work.

"Service Suspension" means the term as described in Section 2(b)(v).

"Subscription Period" means the time during which Customer's Authorized User are authorized under the Agreement to access the Products. The Subscription Period starts and ends on the dates proscribed in the Quote, unless the Agreement is terminated early by either party; then, the Subscription Period ends on the date of termination.

"Term" means the term as described in Section 5(a).

"Terms of Service" means this Terms of Service and License document and all of the exhibits to it, each of which is incorporated and made part of the Terms of Service.

"Third-Party Services" means hardware, software, content, data or services not provided by Renaissance.

"Valid Login Information" means usernames and passwords or other credentials that Customers or Authorized Users use to access the Products.

EXHIBIT B

Additional Terms and Conditions - Services

Customer agrees to the following for any Services ("Training") made available to it either remotely or on-site:

- a. To provide facilities that are conducive to adult learning, including, without limitation, a computer, broadband Internet connection and two-way sound for each of Customer's participants.
- b. To participate in a pre-planning meeting with Renaissance (at least four weeks for on-site; and, at least three days for remote) before the Training, allowing Renaissance to tailor the Training content to the specific needs of the participants. Renaissance will focus the Training on learning outcomes agreed to during the pre-planning meeting. Renaissance will also strive to adapt the Training to meet needs raised at the Training.
- c. To absorb actual out-of-pocket travel expenses incurred due to Customer's last-minute rescheduling or cancellation of the Training and to pay a one-time cancellation fee of up to \$750.
- d. To use any Services within the Subscription Period. Otherwise, Customer risks losing those services, in Renaissance's discretion.
- e. To Renaissance's using third parties to assist with the Services (Renaissance will be responsible for ensuring their integrity and compliance with the Agreement, as well as their compensation and expenses).
- f. To refrain, without Renaissance's written consent, from recording the Training and from copying or sharing any materials or Content.

Exhibit C
Premium Hybrid Products

Freckle

Lalilo

Exhibit D

Data Protection Addendum

Found at <https://doc.renlearn.com/KMNet/R62068.pdf>

Standard Student Data Privacy Agreement

IL-NDPA v1.0a

School District or LEA

Lincolnwood School District 74

and

Provider

Renaissance Learning, Inc.

This Student Data Privacy Agreement (“DPA”) is entered into on the date of full execution (the “Effective Date”) and is entered into by and between:

[Lincolnwood School District 74], located at [6950 N East Prairie Rd
Lincolnwood, IL 60712] (the “Local Education Agency” or “LEA”) and
[Renaissance Learning, Inc.], located at [2911 Peach Street
Wisconsin Rapids, WI 54494] (the “Provider”).

WHEREAS, the Provider is providing educational or digital services to LEA.

WHEREAS, the Provider and LEA recognize the need to protect personally identifiable student information and other regulated data exchanged between them as required by applicable laws and regulations, such as the Family Educational Rights and Privacy Act (“FERPA”) at 20 U.S.C. § 1232g (34 CFR Part 99); the Children’s Online Privacy Protection Act (“COPPA”) at 15 U.S.C. § 6501-6506 (16 CFR Part 312), applicable state privacy laws and regulations and

WHEREAS, the Provider and LEA desire to enter into this DPA for the purpose of establishing their respective obligations and duties in order to comply with applicable laws and regulations.

NOW THEREFORE, for good and valuable consideration, LEA and Provider agree as follows:

1. A description of the Services to be provided, the categories of Student Data that may be provided by LEA to Provider, and other information specific to this DPA are contained in the Standard Clauses hereto.
2. **Special Provisions. Check if Required**
 - If checked, the Supplemental State Terms and attached hereto as **Exhibit “G”** are hereby incorporated by reference into this DPA in their entirety.
 - If checked, LEA and Provider agree to the additional terms or modifications set forth in **Exhibit “H”. (Optional)**
 - If Checked, the Provider, has signed **Exhibit “E”** to the Standard Clauses, otherwise known as General Offer of Privacy Terms
3. In the event of a conflict between the SDPC Standard Clauses, the State or Special Provisions will control. In the event there is conflict between the terms of the DPA and any other writing, including, but not limited to the Service Agreement and Provider Terms of Service or Privacy Policy the terms of this DPA shall control.
4. This DPA shall stay in effect for three years. Exhibit E will expire 3 years from the date the original DPA was signed.
5. The services to be provided by Provider to LEA pursuant to this DPA are detailed in **Exhibit “A”** (the “Services”).
6. **Notices**. All notices or other communication required or permitted to be given hereunder may be given via e-mail transmission, or first-class mail, sent to the designated representatives below.

The designated representative for the LEA for this DPA is:

Name: _____ Title: _____

Address: _____

Phone: _____ Email: _____

The designated representative for the Provider for this DPA is:

Name: Bob Stasio Title: Chief Info & Sec Officer

Address: 2911 Peach Street, Wisconsin Rapids, WI 54494

Phone: (800) 338-4204 Email: infosec@renaissance.com

IN WITNESS WHEREOF, LEA and Provider execute this DPA as of the Effective Date.

LEA: Lincolnwood School District 74

By: _____ Date: _____

Printed Name: _____ Title/Position: _____

Provider: Renaissance Learning, Inc.

By:  _____ Date: 04/18/2023

Printed Name: Scott Johnson Title/Position: Dir. Info Security

STANDARD CLAUSES

Version 1.0

ARTICLE I: PURPOSE AND SCOPE

- Purpose of DPA.** The purpose of this DPA is to describe the duties and responsibilities to protect Student Data including compliance with all applicable federal, state, and local privacy laws, rules, and regulations, all as may be amended from time to time. In performing these services, the Provider shall be considered a School Official with a legitimate educational interest, and performing services otherwise provided by the LEA. Provider shall be under the direct control and supervision of the LEA, with respect to its use of Student Data
- Student Data to Be Provided.** In order to perform the Services described above, LEA shall provide Student Data as identified in the Schedule of Data, attached hereto as **Exhibit “B”**.
- DPA Definitions.** The definition of terms used in this DPA is found in **Exhibit “C”**. In the event of a conflict, definitions used in this DPA shall prevail over terms used in any other writing, including, but not limited to the Service Agreement, Terms of Service, Privacy Policies etc.

ARTICLE II: DATA OWNERSHIP AND AUTHORIZED ACCESS

- Student Data Property of LEA.** All Student Data transmitted to the Provider pursuant to the Service Agreement is and will continue to be the property of and under the control of the LEA. The Provider further acknowledges and agrees that all copies of such Student Data transmitted to the Provider, including any modifications or additions or any portion thereof from any source, are subject to the provisions of this DPA in the same manner as the original Student Data. The Parties agree that as between them, all rights, including all intellectual property rights in and to Student Data contemplated per the Service Agreement, shall remain the exclusive property of the LEA. For the purposes of FERPA, the Provider shall be considered a School Official, under the control and direction of the LEA as it pertains to the use of Student Data, notwithstanding the above.
- Parent Access.** To the extent required by law the LEA shall establish reasonable procedures by which a parent, legal guardian, or eligible student may review Education Records and/or Student Data correct erroneous information, and procedures for the transfer of student-generated content to a personal account, consistent with the functionality of services. Provider shall respond in a reasonably timely manner (and no later than forty five (45) days from the date of the request or pursuant to the time frame required under state law for an LEA to respond to a parent or student, whichever is sooner) to the LEA’s request for Student Data in a student’s records held by the Provider to view or correct as necessary. In the event that a parent of a student or other individual contacts the Provider to review any of the Student Data accessed pursuant to the Services, the Provider shall refer the parent or individual to the LEA, who will follow the necessary and proper procedures regarding the requested information.
- Separate Account.** If Student-Generated Content is stored or maintained by the Provider, Provider shall, at the request of the LEA, transfer, or provide a mechanism for the LEA to transfer, said Student-Generated Content to a separate account created by the student.

4. **Law Enforcement Requests.** Should law enforcement or other government entities (“Requesting Party(ies)”) contact Provider with a request for Student Data held by the Provider pursuant to the Services, the Provider shall notify the LEA in advance of a compelled disclosure to the Requesting Party, unless lawfully directed by the Requesting Party not to inform the LEA of the request.
5. **Subprocessors.** Provider shall enter into written agreements with all Subprocessors performing functions for the Provider in order for the Provider to provide the Services pursuant to the Service Agreement, whereby the Subprocessors agree to protect Student Data in a manner no less stringent than the terms of this DPA.

ARTICLE III: DUTIES OF LEA

1. **Provide Data in Compliance with Applicable Laws.** LEA shall provide Student Data for the purposes of obtaining the Services in compliance with all applicable federal, state, and local privacy laws, rules, and regulations, all as may be amended from time to time.
2. **Annual Notification of Rights.** If the LEA has a policy of disclosing Education Records and/or Student Data under FERPA (34 CFR § 99.31(a)(1)), LEA shall include a specification of criteria for determining who constitutes a school official and what constitutes a legitimate educational interest in its annual notification of rights.
3. **Reasonable Precautions.** LEA shall take reasonable precautions to secure usernames, passwords, and any other means of gaining access to the services and hosted Student Data.
4. **Unauthorized Access Notification.** LEA shall notify Provider promptly of any known unauthorized access. LEA will assist Provider in any efforts by Provider to investigate and respond to any unauthorized access.

ARTICLE IV: DUTIES OF PROVIDER

1. **Privacy Compliance.** The Provider shall comply with all applicable federal, state, and local laws, rules, and regulations pertaining to Student Data privacy and security, all as may be amended from time to time.
2. **Authorized Use.** The Student Data shared pursuant to the Service Agreement, including persistent unique identifiers, shall be used for no purpose other than the Services outlined in Exhibit A or stated in the Service Agreement and/or otherwise authorized under the statutes referred to herein this DPA.
3. **Provider Employee Obligation.** Provider shall require all of Provider’s employees and agents who have access to Student Data to comply with all applicable provisions of this DPA with respect to the Student Data shared under the Service Agreement. Provider agrees to require and maintain an appropriate confidentiality agreement from each employee or agent with access to Student Data pursuant to the Service Agreement.
4. **No Disclosure.** Provider acknowledges and agrees that it shall not make any re-disclosure of any Student Data or any portion thereof, including without limitation, user content or other non-public information and/or personally identifiable information contained in the Student Data other than as directed or

permitted by the LEA or this DPA. This prohibition against disclosure shall not apply to aggregate summaries of De-Identified information, Student Data disclosed pursuant to a lawfully issued subpoena or other legal process, or to subprocessors performing services on behalf of the Provider pursuant to this DPA. Provider will not Sell Student Data to any third party.

5. **De-Identified Data**: Provider agrees not to attempt to re-identify de-identified Student Data. De-Identified Data may be used by the Provider for those purposes allowed under FERPA and the following purposes: (1) assisting the LEA or other governmental agencies in conducting research and other studies; and (2) research and development of the Provider's educational sites, services, or applications, and to demonstrate the effectiveness of the Services; and (3) for adaptive learning purpose and for customized student learning. Provider's use of De-Identified Data shall survive termination of this DPA or any request by LEA to return or destroy Student Data. Except for Subprocessors, Provider agrees not to transfer de-identified Student Data to any party unless (a) that party agrees in writing not to attempt re-identification, and (b) prior written notice has been given to the LEA who has provided prior written consent for such transfer. Prior to publishing any document that names the LEA explicitly or indirectly, the Provider shall obtain the LEA's written approval of the manner in which de-identified data is presented.
6. **Disposition of Data**. Upon written request from the LEA, Provider shall dispose of or provide a mechanism for the LEA to transfer Student Data obtained under the Service Agreement, within sixty (60) days of the date of said request and according to a schedule and procedure as the Parties may reasonably agree. Upon termination of this DPA, if no written request from the LEA is received, Provider shall dispose of all Student Data after providing the LEA with reasonable prior notice. The duty to dispose of Student Data shall not extend to Student Data that had been De-Identified or placed in a separate student account pursuant to section II 3. The LEA may employ a "Directive for Disposition of Data" form, a copy of which is attached hereto as **Exhibit "D"**. If the LEA and Provider employ Exhibit "D," no further written request or notice is required on the part of either party prior to the disposition of Student Data described in Exhibit "D".
7. **Advertising Limitations**. Provider is prohibited from using, disclosing, or selling Student Data to (a) inform, influence, or enable Targeted Advertising; or (b) develop a profile of a student, family member/guardian or group, for any purpose other than providing the Service to LEA. This section does not prohibit Provider from using Student Data (i) for adaptive learning or customized student learning (including generating personalized learning recommendations); or (ii) to make product recommendations to teachers or LEA employees; or (iii) to notify account holders about new education product updates, features, or services or from otherwise using Student Data as permitted in this DPA and its accompanying exhibits

ARTICLE V: DATA PROVISIONS

1. **Data Storage**. Where required by applicable law, Student Data shall be stored within the United States. Upon request of the LEA, Provider will provide a list of the locations where Student Data is stored.
2. **Audits**. No more than once a year, or following unauthorized access, upon receipt of a written request from the LEA with at least ten (10) business days' notice and upon the execution of an appropriate confidentiality agreement, the Provider will allow the LEA to audit the security and privacy measures that are in place to ensure protection of Student Data or any portion thereof as it pertains to the delivery of services to the LEA . The Provider will cooperate reasonably with the LEA and any local, state, or federal

agency with oversight authority or jurisdiction in connection with any audit or investigation of the Provider and/or delivery of Services to students and/or LEA, and shall provide reasonable access to the Provider's facilities, staff, agents and LEA's Student Data and all records pertaining to the Provider, LEA and delivery of Services to the LEA. Failure to reasonably cooperate shall be deemed a material breach of the DPA.

3. **Data Security.** The Provider agrees to utilize administrative, physical, and technical safeguards designed to protect Student Data from unauthorized access, disclosure, acquisition, destruction, use, or modification. The Provider shall adhere to any applicable law relating to data security. The provider shall implement an adequate Cybersecurity Framework based on one of the nationally recognized standards set forth set forth in **Exhibit "F"**. Exclusions, variations, or exemptions to the identified Cybersecurity Framework must be detailed in an attachment to **Exhibit "H"**. Additionally, Provider may choose to further detail its security programs and measures that augment or are in addition to the Cybersecurity Framework in **Exhibit "F"**. Provider shall provide, in the Standard Schedule to the DPA, contact information of an employee who LEA may contact if there are any data security concerns or questions.
4. **Data Breach.** In the event of an unauthorized release, disclosure or acquisition of Student Data that compromises the security, confidentiality or integrity of the Student Data maintained by the Provider the Provider shall provide notification to LEA within seventy-two (72) hours of confirmation of the incident, unless notification within this time limit would disrupt investigation of the incident by law enforcement. In such an event, notification shall be made within a reasonable time after the incident. Provider shall follow the following process:
 - (1) The security breach notification described above shall include, at a minimum, the following information to the extent known by the Provider and as it becomes available:
 - i. The name and contact information of the reporting LEA subject to this section.
 - ii. A list of the types of personal information that were or are reasonably believed to have been the subject of a breach.
 - iii. If the information is possible to determine at the time the notice is provided, then either (1) the date of the breach, (2) the estimated date of the breach, or (3) the date range within which the breach occurred. The notification shall also include the date of the notice.
 - iv. Whether the notification was delayed as a result of a law enforcement investigation, if that information is possible to determine at the time the notice is provided; and
 - v. A general description of the breach incident, if that information is possible to determine at the time the notice is provided.
 - (2) Provider agrees to adhere to all federal and state requirements with respect to a data breach related to the Student Data, including, when appropriate or required, the required responsibilities and procedures for notification and mitigation of any such data breach.
 - (3) Provider further acknowledges and agrees to have a written incident response plan that reflects best practices and is consistent with industry standards and federal and state law for responding to a data breach, breach of security, privacy incident or unauthorized acquisition or use of Student Data or any portion thereof, including personally identifiable information and agrees to provide LEA, upon request, with a summary of said written incident response plan.

- (4) LEA shall provide notice and facts surrounding the breach to the affected students, parents or guardians.
- (5) In the event of a breach originating from LEA's use of the Service, Provider shall cooperate with LEA to the extent necessary to expeditiously secure Student Data.

ARTICLE VI: GENERAL OFFER OF TERMS

Provider may, by signing the attached form of "General Offer of Privacy Terms" (General Offer, attached hereto as **Exhibit "E"**), be bound by the terms of **Exhibit "E"** to any other LEA who signs the acceptance on said Exhibit. The form is limited by the terms and conditions described therein.

ARTICLE VII: MISCELLANEOUS

1. **Termination.** In the event that either Party seeks to terminate this DPA, they may do so by mutual written consent so long as the Service Agreement has lapsed or has been terminated. Either party may terminate this DPA and any service agreement or contract if the other party breaches any terms of this DPA.
2. **Effect of Termination Survival.** If the Service Agreement is terminated, the Provider shall destroy all of LEA's Student Data pursuant to Article IV, section 6.
3. **Priority of Agreements.** This DPA shall govern the treatment of Student Data in order to comply with the privacy protections, including those found in FERPA and all applicable privacy statutes identified in this DPA. In the event there is conflict between the terms of the DPA and the Service Agreement, Terms of Service, Privacy Policies, or with any other bid/RFP, license agreement, or writing, the terms of this DPA shall apply and take precedence. In the event of a conflict between Exhibit H, the SDPC Standard Clauses, and/or the Supplemental State Terms, Exhibit H will control, followed by the Supplemental State Terms. Except as described in this paragraph herein, all other provisions of the Service Agreement shall remain in effect.
4. **Entire Agreement.** This DPA and the Service Agreement constitute the entire agreement of the Parties relating to the subject matter hereof and supersedes all prior communications, representations, or agreements, oral or written, by the Parties relating thereto. This DPA may be amended and the observance of any provision of this DPA may be waived (either generally or in any particular instance and either retroactively or prospectively) only with the signed written consent of both Parties. Neither failure nor delay on the part of any Party in exercising any right, power, or privilege hereunder shall operate as a waiver of such right, nor shall any single or partial exercise of any such right, power, or privilege preclude any further exercise thereof or the exercise of any other right, power, or privilege.

5. **Severability**. Any provision of this DPA that is prohibited or unenforceable in any jurisdiction shall, as to such jurisdiction, be ineffective to the extent of such prohibition or unenforceability without invalidating the remaining provisions of this DPA, and any such prohibition or unenforceability in any jurisdiction shall not invalidate or render unenforceable such provision in any other jurisdiction. Notwithstanding the foregoing, if such provision could be more narrowly drawn so as not to be prohibited or unenforceable in such jurisdiction while, at the same time, maintaining the intent of the Parties, it shall, as to such jurisdiction, be so narrowly drawn without invalidating the remaining provisions of this DPA or affecting the validity or enforceability of such provision in any other jurisdiction.
6. **Governing Law; Venue and Jurisdiction**. THIS DPA WILL BE GOVERNED BY AND CONSTRUED IN ACCORDANCE WITH THE LAWS OF THE STATE OF THE LEA, WITHOUT REGARD TO CONFLICTS OF LAW PRINCIPLES. EACH PARTY CONSENTS AND SUBMITS TO THE SOLE AND EXCLUSIVE JURISDICTION TO THE STATE AND FEDERAL COURTS FOR THE COUNTY OF THE LEA FOR ANY DISPUTE ARISING OUT OF OR RELATING TO THIS DPA OR THE TRANSACTIONS CONTEMPLATED HEREBY.
7. **Successors Bound**: This DPA is and shall be binding upon the respective successors in interest to Provider in the event of a merger, acquisition, consolidation or other business reorganization or sale of all or substantially all of the assets of such business In the event that the Provider sells, merges, or otherwise disposes of its business to a successor during the term of this DPA, the Provider shall provide written notice to the LEA no later than sixty (60) days after the closing date of sale, merger, or disposal. Such notice shall include a written, signed assurance that the successor will assume the obligations of the DPA and any obligations with respect to Student Data within the Service Agreement. The LEA has the authority to terminate the DPA if it disapproves of the successor to whom the Provider is selling, merging, or otherwise disposing of its business.
8. **Authority**. Each party represents that it is authorized to bind to the terms of this DPA, including confidentiality and destruction of Student Data and any portion thereof contained therein, all related or associated institutions, individuals, employees or contractors who may have access to the Student Data and/or any portion thereof.
9. **Waiver**. No delay or omission by either party to exercise any right hereunder shall be construed as a waiver of any such right and both parties reserve the right to exercise any such right from time to time, as often as may be deemed expedient.

EXHIBIT "A"
DESCRIPTION OF SERVICES

As a global leader in assessment, reading, and math solutions for pre-K-12 schools and districts, Renaissance is committed to providing educators with insights and resources to accelerate growth and help all students build a strong foundation for success. Renaissance solutions reach more than 40 percent of US schools and more than half a million students in other regions across the world. Our portfolio includes solutions for assessment (Star Assessments, Star Phonics, myIGDIs for Preschool, FastBridge, DnA, and SchoolCity); practice (Accelerated Reader, myON, Freckle, and Lalilo); and data-driven insights (eduCLIMBER and Schoolzilla).

EXHIBIT "B"
SCHEDULE OF DATA

Category of Data	Elements	Check if Used by Your System
Application Technology Meta Data	IP Addresses of users, Use of cookies, etc.	<input type="checkbox"/>
	Other application technology meta data-Please specify:	<input type="checkbox"/>
Application Use Statistics	Meta data on user interaction with application	<input type="checkbox"/>
Assessment	Standardized test scores	<input type="checkbox"/>
	Observation data	<input type="checkbox"/>
	Other assessment data-Please specify:	<input type="checkbox"/>
Attendance	Student school (daily) attendance data	<input type="checkbox"/>
	Student class attendance data	<input type="checkbox"/>
Communications	Online communications captured (emails, blog entries)	<input type="checkbox"/>
Conduct	Conduct or behavioral data	<input type="checkbox"/>
Demographics	Date of Birth	<input type="checkbox"/>
	Place of Birth	<input type="checkbox"/>
	Gender	<input type="checkbox"/>
	Ethnicity or race	<input type="checkbox"/>
	Language information (native, or primary language spoken by student)	<input type="checkbox"/>
	Other demographic information-Please specify:	<input type="checkbox"/>
Enrollment	Student school enrollment	<input type="checkbox"/>
	Student grade level	<input type="checkbox"/>
	Homeroom	<input type="checkbox"/>
	Guidance counselor	<input type="checkbox"/>
	Specific curriculum programs	<input type="checkbox"/>
	Year of graduation	<input type="checkbox"/>
	Other enrollment information-Please specify:	<input type="checkbox"/>
Parent/Guardian Contact Information	Address	<input type="checkbox"/>
	Email	<input type="checkbox"/>

Category of Data	Elements	Check if Used by Your System	
	Phone	<input type="checkbox"/>	<input type="checkbox"/>
Parent/Guardian ID	Parent ID number (created to link parents to students)	<input type="checkbox"/>	<input type="checkbox"/>
Parent/Guardian Name	First and/or Last	<input type="checkbox"/>	<input type="checkbox"/>
Schedule	Student scheduled courses	<input type="checkbox"/>	<input type="checkbox"/>
	Teacher names	<input type="checkbox"/>	<input type="checkbox"/>
Special Indicator	English language learner information	<input type="checkbox"/>	<input type="checkbox"/>
	Low income status	<input type="checkbox"/>	<input type="checkbox"/>
	Medical alerts/ health data	<input type="checkbox"/>	<input type="checkbox"/>
	Student disability information	<input type="checkbox"/>	<input type="checkbox"/>
	Specialized education services (IEP or 504)	<input type="checkbox"/>	<input type="checkbox"/>
	Living situations (homeless/foster care)	<input type="checkbox"/>	<input type="checkbox"/>
	Other indicator information-Please specify:	<input type="checkbox"/>	<input type="checkbox"/>
Student Contact Information	Address	<input type="checkbox"/>	<input type="checkbox"/>
	Email	<input type="checkbox"/>	<input type="checkbox"/>
	Phone	<input type="checkbox"/>	<input type="checkbox"/>
Student Identifiers	Local (School district) ID number	<input type="checkbox"/>	<input type="checkbox"/>
	State ID number	<input type="checkbox"/>	<input type="checkbox"/>
	Provider/App assigned student ID number	<input type="checkbox"/>	<input type="checkbox"/>
	Student app username	<input type="checkbox"/>	<input type="checkbox"/>
	Student app passwords	<input type="checkbox"/>	<input type="checkbox"/>
Student Name	First and/or Last	<input type="checkbox"/>	<input type="checkbox"/>
Student In App Performance	Program/application performance (typing program-student types 60 wpm, reading program-student reads below grade level)	<input type="checkbox"/>	<input type="checkbox"/>
Student Program Membership	Academic or extracurricular activities a student may belong to or participate in	<input type="checkbox"/>	<input type="checkbox"/>
Student Survey Responses	Student responses to surveys or questionnaires	<input type="checkbox"/>	<input type="checkbox"/>
Student work	Student generated content; writing, pictures, etc.	<input type="checkbox"/>	<input type="checkbox"/>
	Other student work data -Please specify:	<input type="checkbox"/>	<input type="checkbox"/>
Transcript	Student course grades	<input type="checkbox"/>	<input type="checkbox"/>
	Student course data	<input type="checkbox"/>	<input type="checkbox"/>

Category of Data	Elements	Check if Used by Your System
	Student course grades/ performance scores	<input type="checkbox"/>
	Other transcript data - Please specify:	<input type="checkbox"/>
Transportation	Student bus assignment	<input type="checkbox"/>
	Student pick up and/or drop off location	<input type="checkbox"/>
	Student bus card ID number	<input type="checkbox"/>
	Other transportation data – Please specify:	<input type="checkbox"/>
Other	<p>Please list each additional data element used, stored, or collected by your application:</p> <p>Please refer to the attached Categories of Data Collected by Product for full details.</p>	<input type="checkbox"/>
None	No Student Data collected at this time. Provider will immediately notify LEA if this designation is no longer applicable.	<input type="checkbox"/>

EXHIBIT "C" DEFINITIONS

De-Identified Data and De-Identification: Records and information are considered to be De-Identified when all personally identifiable information has been removed or obscured, such that the remaining information does not reasonably identify a specific individual, including, but not limited to, any information that, alone or in combination is linkable to a specific student and provided that the educational agency, or other party, has made a reasonable determination that a student's identity is not personally identifiable, taking into account reasonable available information.

Educational Records: Educational Records are records, files, documents, and other materials directly related to a student and maintained by the school or local education agency, or by a person acting for such school or local education agency, including but not limited to, records encompassing all the material kept in the student's cumulative folder, such as general identifying data, records of attendance and of academic work completed, records of achievement, and results of evaluative tests, health data, disciplinary status, test protocols and individualized education programs.

Metadata: means information that provides meaning and context to other data being collected; including, but not limited to: date and time records and purpose of creation Metadata that have been stripped of all direct and indirect identifiers are not considered Personally Identifiable Information.

Operator: means the operator of an internet website, online service, online application, or mobile application with actual knowledge that the site, service, or application is used for K-12 school purposes. Any entity that operates an internet website, online service, online application, or mobile application that has entered into a signed, written agreement with an LEA to provide a service to that LEA shall be considered an "operator" for the purposes of this section.

Originating LEA: An LEA who originally executes the DPA in its entirety with the Provider.

Provider: For purposes of the DPA, the term "Provider" means provider of digital educational software or services, including cloud-based services, for the digital storage, management, and retrieval of Student Data. Within the DPA the term "Provider" includes the term "Third Party" and the term "Operator" as used in applicable state statutes.

Student Generated Content: The term "Student-Generated Content" means materials or content created by a student in the services including, but not limited to, essays, research reports, portfolios, creative writing, music or other audio files, photographs, videos, and account information that enables ongoing ownership of student content.

School Official: For the purposes of this DPA and pursuant to 34 CFR § 99.31(b), a School Official is a contractor that: (1) Performs an institutional service or function for which the agency or institution would otherwise use employees; (2) Is under the direct control of the agency or institution with respect to the use and maintenance of Student Data including Education Records; and (3) Is subject to 34 CFR § 99.33(a) governing the use and re-disclosure of Personally Identifiable Information from Education Records.

Service Agreement: Refers to the Contract, Purchase Order or Terms of Service or Terms of Use.

Student Data: Student Data includes any data, whether gathered by Provider or provided by LEA or its users, students, or students' parents/guardians, that is descriptive of the student including, but not limited to,

information in the student's educational record or email, first and last name, birthdate, home or other physical address, telephone number, email address, or other information allowing physical or online contact, discipline records, videos, test results, special education data, juvenile dependency records, grades, evaluations, criminal records, medical records, health records, social security numbers, biometric information, disabilities, socioeconomic information, individual purchasing behavior or preferences, food purchases, political affiliations, religious information, text messages, documents, student identifiers, search activity, photos, voice recordings, geolocation information, parents' names, or any other information or identification number that would provide information about a specific student. Student Data includes Meta Data. Student Data further includes "Personally Identifiable Information (PII)," as defined in 34 C.F.R. § 99.3 and as defined under any applicable state law. Student Data shall constitute Education Records for the purposes of this DPA, and for the purposes of federal, state, and local laws and regulations. Student Data as specified in **Exhibit "B"** is confirmed to be collected or processed by the Provider pursuant to the Services. Student Data shall not constitute that information that has been anonymized or De-Identified, or anonymous usage data regarding a student's use of Provider's services.

Subprocessor: For the purposes of this DPA, the term "Subprocessor" (sometimes referred to as the "Subcontractor") means a party other than LEA or Provider, who Provider uses for data collection, analytics, storage, or other service to operate and/or improve its service, and who has access to Student Data.

Subscribing LEA: An LEA that was not party to the original Service Agreement and who accepts the Provider's General Offer of Privacy Terms.

Targeted Advertising: means presenting an advertisement to a student where the selection of the advertisement is based on Student Data or inferred over time from the usage of the operator's Internet web site, online service or mobile application by such student or the retention of such student's online activities or requests over time for the purpose of targeting subsequent advertisements. "Targeted Advertising" does not include any advertising to a student on an Internet web site based on the content of the web page or in response to a student's response or request for information or feedback.

Third Party: The term "Third Party" means a provider of digital educational software or services, including cloud-based services, for the digital storage, management, and retrieval of Education Records and/or Student Data, as that term is used in some state statutes. However, for the purpose of this DPA, the term "Third Party" when used to indicate the provider of digital educational software or services is replaced by the term "Provider."

EXHIBIT "D"
DIRECTIVE FOR DISPOSITION OF DATA

Provider to dispose of data obtained by Provider pursuant to the terms of the Service Agreement between LEA and Provider. The terms of the Disposition are set forth below:

1. Extent of Disposition

Disposition is partial. The categories of data to be disposed of are set forth below or are found in an attachment to this Directive:

[]

Disposition is Complete. Disposition extends to all categories of data.

2. Nature of Disposition

Disposition shall be by destruction or deletion of data.

Disposition shall be by a transfer of data. The data shall be transferred to the following site as follows:

[]

3. Schedule of Disposition

Data shall be disposed of by the following date:

As soon as commercially practicable.

By []

4. Signature

Authorized Representative of LEA

Date

5. Verification of Disposition of Data

Authorized Representative of Company

Date

EXHIBIT "E"
GENERAL OFFER OF PRIVACY TERMS

1. Offer of Terms

Provider offers the same privacy protections found in this DPA between it and Lincolnwood School District 74 ("Originating LEA") which is dated _____, to any other LEA ("Subscribing LEA") who accepts this General Offer of Privacy Terms ("General Offer") through its signature below. This General Offer shall extend only to privacy protections, and Provider's signature shall not necessarily bind Provider to other terms, such as price, term, or schedule of services, or to any other provision not addressed in this DPA. The Provider and the Subscribing LEA may also agree to change the data provided by Subscribing LEA to the Provider to suit the unique needs of the Subscribing LEA. The Provider may withdraw the General Offer in the event of: (1) a material change in the applicable privacy statutes; (2) a material change in the services and products listed in the originating Service Agreement; or three (3) years after the date of Provider's signature to this Form. Subscribing LEAs should send the signed **Exhibit "E"** to Provider at the following email address: contracts@renaissance.com.

PROVIDER: Renaissance Learning, Inc.

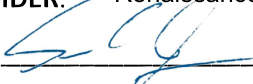
BY:  _____ Date: 04/18/2023

Printed Name: Scott Johnson Title/Position: Dir. Info Security

2. Subscribing LEA

A Subscribing LEA, by signing a separate Service Agreement with Provider, and by its signature below, accepts the General Offer of Privacy Terms. The Subscribing LEA and the Provider shall therefore be bound by the same terms of this DPA for the term of the DPA between the Lincolnwood School District 74 and Renaissance Learning, Inc.

****PRIOR TO ITS EFFECTIVENESS, SUBSCRIBING LEA MUST DELIVER NOTICE OF ACCEPTANCE TO PROVIDER PURSUANT TO ARTICLE VII, SECTION 5. ****

Subscribing LEA:

BY: _____ Date: _____

Printed Name: _____ Title/Position: _____

SCHOOL DISTRICT NAME: _____

DESIGNATED REPRESENTATIVE OF LEA:

Name: _____

Title: _____

Address: _____

Telephone Number: _____

Email: _____

**EXHIBIT “F”
DATA SECURITY REQUIREMENTS**

**Adequate Cybersecurity Frameworks
2/24/2020**

The Education Security and Privacy Exchange (“Edspex”) works in partnership with the Student Data Privacy Consortium and industry leaders to maintain a list of known and credible cybersecurity frameworks which can protect digital learning ecosystems chosen based on a set of guiding cybersecurity principles* (“Cybersecurity Frameworks”) that may be utilized by Provider .

Cybersecurity Frameworks

	MAINTAINING ORGANIZATION/GROUP	FRAMEWORK(S)
<input type="checkbox"/>	National Institute of Standards and Technology	NIST Cybersecurity Framework Version 1.1
<input checked="" type="checkbox"/>	National Institute of Standards and Technology	NIST SP 800-53, Cybersecurity Framework for Improving Critical Infrastructure Cybersecurity (CSF), Special Publication 800-171
<input type="checkbox"/>	International Standards Organization	Information technology — Security techniques — Information security management systems (ISO 27000 series)
<input type="checkbox"/>	Secure Controls Framework Council, LLC	Security Controls Framework (SCF)
<input type="checkbox"/>	Center for Internet Security	CIS Critical Security Controls (CSC, CIS Top 20)
<input type="checkbox"/>	Office of the Under Secretary of Defense for Acquisition and Sustainment (OUSD(A&S))	Cybersecurity Maturity Model Certification (CMMC, ~FAR/DFAR)

Please visit <http://www.edspex.org> for further details about the noted frameworks.

*Cybersecurity Principles used to choose the Cybersecurity Frameworks are located here

EXHIBIT "G" - Supplemental SDPC (Student Data Privacy Consortium) State Terms for Illinois

Version IL-NDPAv1.0a (Revised March 15, 2021)

This **Exhibit G**, Supplemental SDPC State Terms for Illinois ("Supplemental State Terms"), effective simultaneously with the attached Student Data Privacy Agreement ("DPA") by and between Lincolnwood School District 74

_____ (the "Local Education Agency" or "LEA") and Renaissance Learning, Inc. _____ (the "Provider"), is incorporated in the attached DPA and amends the DPA (and all supplemental terms and conditions and policies applicable to the DPA) as follows:

1. **Compliance with Illinois Privacy Laws.** In performing its obligations under the Agreement, the Provider shall comply with all Illinois laws and regulations pertaining to student data privacy, confidentiality, and maintenance, including but not limited to the Illinois School Student Records Act ("ISSRA"), 105 ILCS 10/, Mental Health and Developmental Disabilities Confidentiality Act ("MHDDCA"), 740 ILCS 110/, Student Online Personal Protection Act ("SOPPA"), 105 ILCS 85/, Identity Protection Act ("IPA"), 5 ILCS 179/, and Personal Information Protection Act ("PIPA"), 815 ILCS 530/, and Local Records Act ("LRA"), 50 ILCS 205/.

2. **Definition of "Student Data."** In addition to the definition set forth in **Exhibit C**, Student Data includes any and all information concerning a student by which a student may be individually identified under applicable Illinois law and regulations, including but not limited to (a) "covered information," as defined in Section 5 of SOPPA (105 ILCS 85/5), (b) "school student records" as that term is defined in Section 2 of ISSRA (105 ILCS 10/2(d)) (c) "records" as that term is defined under Section 110/2 of the MHDDCA (740 ILCS 110/2), and (d) "personal information" as defined in Section 530/5 of PIPA.

3. **School Official Designation.** Pursuant to Article I, Paragraph 1 of the DPA Standard Clauses, and in accordance with FERPA, ISSRA and SOPPA, in performing its obligations under the DPA, the Provider is acting as a school official with legitimate educational interest; is performing an institutional service or function for which the LEA would otherwise use its own employees; is under the direct control of the LEA with respect to the use and maintenance of Student Data; and is using Student Data only for an authorized purpose and in furtherance of such legitimate educational interest.

4. **Limitations on Re-Disclosure.** The Provider shall not re-disclose Student Data to any other party or affiliate without the express written permission of the LEA or pursuant to court order, unless such disclosure is otherwise permitted under SOPPA, ISSRA, FERPA, and MHDDCA. Provider will not sell or rent Student Data. In the event another party, including law enforcement or a government entity, contacts the Provider with a request or subpoena for Student Data in the possession of the Provider, the Provider shall redirect the other party to seek the data directly from the LEA. In the event the Provider is compelled to produce Student Data to another party in compliance with a court order, Provider shall notify the LEA at least five (5) school days in advance of the court ordered disclosure and, upon request, provide the LEA with a copy of the court order requiring such disclosure.

5. **Notices.** Any notice delivered pursuant to the DPA shall be deemed effective, as applicable, upon receipt as evidenced by the date of transmission indicated on the transmission material, if by e-mail; or four (4) days after mailing, if by first-class mail, postage prepaid.

6. **Parent Right to Access and Challenge Student Data.** The LEA shall establish reasonable procedures pursuant to which a parent, as that term is defined in 105 ILCS 10/2(g), may inspect and/or

copy Student Data and/or challenge the accuracy, relevance or propriety of Student Data, pursuant to Sections 5 and 7 of ISSRA (105 ILCS 10/5; 105 ILCS 10/7) and Section 33 of SOPPA (105 ILCS 85/33). The Provider shall respond to any request by the LEA for Student Data in the possession of the Provider when Provider cooperation is required to afford a parent an opportunity to inspect and/or copy the Student Data, no later than 5 business days from the date of the request. In the event that a parent contacts the Provider directly to inspect and/or copy Student Data, the Provider shall refer the parent to the LEA, which shall follow the necessary and proper procedures regarding the requested Student Data.

7. **Corrections to Factual Inaccuracies.** In the event that the LEA determines that the Provider is maintaining Student Data that contains a factual inaccuracy, and Provider cooperation is required in order to make a correction, the LEA shall notify the Provider of the factual inaccuracy and the correction to be made. No later than 90 calendar days after receiving the notice of the factual inaccuracy, the Provider shall correct the factual inaccuracy and shall provide written confirmation of the correction to the LEA.

8. **Security Standards.** The Provider shall implement and maintain commercially reasonable security procedures and practices that otherwise meet or exceed industry standards designed to protect Student Data from unauthorized access, destruction, use, modification, or disclosure, including but not limited to the unauthorized acquisition of computerized data that compromises the security, confidentiality, or integrity of the Student Data (a "Security Breach"). For purposes of the DPA and this Exhibit G, "Security Breach" does not include the good faith acquisition of Student Data by an employee or agent of the Provider or LEA for a legitimate educational or administrative purpose of the Provider or LEA, so long as the Student Data is used solely for purposes permitted by SOPPA and other applicable law, and so long as the Student Data is restricted from further unauthorized disclosure.

9. **Security Breach Notification.** In addition to the information enumerated in Article V, Section 4(1) of the DPA Standard Clauses, any Security Breach notification provided by the Provider to the LEA shall include:

- a. A list of the students whose Student Data was involved in or is reasonably believed to have been involved in the breach, if known; and
- b. The name and contact information for an employee of the Provider whom parents may contact to inquire about the breach.

10. **Reimbursement of Expenses Associated with Security Breach.** In the event of a Security Breach that is attributable to the Provider, the Provider shall reimburse and indemnify the LEA for any and all costs and expenses that the LEA incurs in investigating and remediating the Security Breach, without regard to any limitation of liability provision otherwise agreed to between Provider and LEA, including but not limited to costs and expenses associated with:

- a. Providing notification to the parents of those students whose Student Data was compromised and regulatory agencies or other entities as required by law or contract;
- b. Providing credit monitoring to those students whose Student Data was exposed in a manner during the Security Breach that a reasonable person would believe may impact the student's credit or financial security;
- c. Legal fees, audit costs, fines, and any other fees or damages imposed against the LEA

as a result of the security breach; and

- d. Providing any other notifications or fulfilling any other requirements adopted by the Illinois State Board of Education or under other State or federal laws.

11. Transfer or Deletion of Student Data. The Provider shall review, on an annual basis, whether the Student Data it has received pursuant to the DPA continues to be needed for the purpose(s) of the Service Agreement and this DPA. If any of the Student Data is no longer needed for purposes of the Service Agreement and this DPA, the Provider will provide written notice to the LEA as to what Student Data is no longer needed. The Provider will delete or transfer Student Data in readable form to the LEA, as directed by the LEA (which may be effectuated through Exhibit D of the DPA), within 30 calendar days if the LEA requests deletion or transfer of the Student Data and shall provide written confirmation to the LEA of such deletion or transfer. Upon termination of the Service Agreement between the Provider and LEA, Provider shall conduct a final review of Student Data within 60 calendar days.

If the LEA receives a request from a parent, as that term is defined in 105 ILCS 10/2(g), that Student Data being held by the Provider be deleted, the LEA shall determine whether the requested deletion would violate State and/or federal records laws. In the event such deletion would not violate State or federal records laws, the LEA shall forward the request for deletion to the Provider. The Provider shall comply with the request and delete the Student Data within a reasonable time period after receiving the request.

Any provision of Student Data to the LEA from the Provider shall be transmitted in a format readable by the LEA.

12. Public Posting of DPA. Pursuant to SOPPA, the LEA shall publish on its website a copy of the DPA between the Provider and the LEA, including this Exhibit G.

13. Subcontractors. By no later than (5) business days after the date of execution of the DPA, the Provider shall provide the LEA with a list of any subcontractors to whom Student Data may be disclosed or a link to a page on the Provider's website that clearly lists any and all subcontractors to whom Student Data may be disclosed. This list shall, at a minimum, be updated and provided to the LEA by the beginning of each fiscal year (July 1) and at the beginning of each calendar year (January 1).

14. DPA Term.

- a. **Original DPA.** Paragraph 4 on page 2 of the DPA setting a three-year term for the DPA shall be deleted, and the following shall be inserted in lieu thereof: "This DPA shall be effective upon the date of signature by Provider and LEA, and shall remain in effect as between Provider and LEA 1) for so long as the Services are being provided to the LEA or 2) until the DPA is terminated pursuant to Section 15 of this Exhibit G, whichever comes first. The Exhibit E General Offer will expire three (3) years from the date the original DPA was signed."
- b. **General Offer DPA.** The following shall be inserted as a new second sentence in Paragraph 1 of Exhibit E: "The provisions of the original DPA offered by Provider and accepted by Subscribing LEA pursuant to this Exhibit E shall remain in effect as between Provider and Subscribing LEA 1) for so long as the Services are being provided to Subscribing LEA, or 2) until the DPA is terminated pursuant to Section 15 of this Exhibit G, whichever comes first."

15. **Termination.** Paragraph 1 of Article VII shall be deleted, and the following shall be inserted in lieu thereof: "In the event either Party seeks to terminate this DPA, they may do so by mutual written consent so long as the Service Agreement has lapsed or been terminated. One party may terminate this DPA upon a material breach of this DPA by the other party. Upon termination of the DPA, the Service Agreement shall terminate."
16. **Privacy Policy.** The Provider must publicly disclose material information about its collection, use, and disclosure of Student Data, including, but not limited to, publishing a terms of service agreement, privacy policy, or similar document.
17. **Minimum Data Necessary Shared.** The Provider attests that the Student Data request by the Provider from the LEA in order for the LEA to access the Provider's products and/or services is limited to the Student Data that is adequate, relevant, and limited to what is necessary in relation to the K-12 school purposes for which it is processed.
18. **Student and Parent Access.** Access by students or parents/guardians to the Provider's programs or services governed by the DPA or to any Student Data stored by Provider shall not be conditioned upon agreement by the parents/guardians to waive any of the student data confidentiality restrictions or a lessening of any of the confidentiality or privacy requirements contained in this DPA.
19. **Data Storage.** Provider shall store all Student Data shared under the DPA within the United States.
20. **Exhibits A and B.** The Services described in Exhibit A and the Schedule of Data in Exhibit B to the DPA satisfy the requirements in SOPPA to include a statement of the product or service being provided to the school by the Provider and a listing of the categories or types of covered information to be provided to the Provider, respectively.

EXHIBIT“ H’
Additional Terms or Modifications
Version _____

LEA and Provider agree to the following additional terms and modifications:

This is a free text field that the parties can use to add or modify terms in or to the DPA. If there are no additional or modified terms, this field should read “None.”

LEA and Provider agree that the following sections are amended in their entirety as follows:

- WHEREAS, the Provider and LEA recognize the need to protect personally identifiable student information and other regulated data exchanged between them as required by applicable laws and regulations, such as the Family Educational Rights and Privacy Act (“FERPA”) at 10 U.S.C § 1232g (34 CFR Part 99); and to the extent applicable, the Children’s Online Privacy and Protection Act (“COPPA”) at 15 U.S.C. § 6501-6506 (16 CFR Part 312), applicable state privacy laws and regulations and...
- Page 2, Section 3. In the event of a conflict between the SDPC Standard Clauses, the State or Special Provisions will control. In the event there is conflict between the terms of the DPA and any other writing, including, but not limited to the Service Agreement and Provider Terms of Service or Privacy Policy the terms of this DPA the Provider’s DPA which is available here <https://renaissance.widen.net/view/pdf/rtvix11tcw/US-Terms-of-Service-and-License---Exhibit-D---Personal-Data-Annex.pdf?t.download=true&u=zceria> and incorporated by reference, Provider’s DPA shall control.
- Page 5, Section 4, No Disclosure. No Disclosure. Provider acknowledges and agrees that it shall not make any re-disclosure of any Student Data or any portion thereof, including without limitation, user content or other non-public information and/or personally identifiable information contained in the Student Data other than as directed or permitted by the LEA or this DPA. This prohibition against disclosure shall not apply to aggregate summaries of De-Identified information, Student Data disclosed pursuant to a lawfully issued subpoena or other legal process, or to subprocessors performing services on behalf of the Provider pursuant to this DPA. Provider will not Sell Student Data to any third party.
- Page 6, Section 2, Audits. No more than once a year, or following a confirmed unauthorized access, upon receipt of a written request from the LEA with at least ~~ten (10)~~thirty (30) business days’ notice and upon the execution of an appropriate confidentiality agreement, the Provide will allow the LEA to audit the security and privacy measures that are in place to ensure protection of Student Data or any portion thereof as it pertains to the delivery of services to the LEA. The Provider will cooperate reasonably with the LEA and any local, state, or federal agency with oversight authority or jurisdiction in connection with any audit or investigation of the Provider and/or delivery of Services to students and/or LEA, and shall provide reasonable access to the Provider’s facilities, staff, agents and LEA’s Student Data and all records pertaining to the Provider, LEA and delivery of Services to the LEA. Failure to reasonably cooperate shall be deemed a material breach of the DPA.
- Page 6, Section 5. De-Identified Data: Provider agrees not to attempt to re-identify de-identified Student Data. De-Identified Data may be used by the Provider for those purposes allowed under FERPA and the following purposes: (1) assisting the LEA or other governmental agencies in conducting research and other studies; and (2) research and development of the Provider's educational sites, services, or applications, and to demonstrate the effectiveness of the Services; ~~and (3) for adaptive learning purpose and for customized student learning;~~ and (4) for any lawful purpose. Provider's use of De-Identified Data shall survive termination of this DPA or any request by LEA to return or destroy Student Data. Except for Subprocessors, Provider agrees not to transfer deidentified Student Data to any party unless ~~(a) that party agrees in writing not to attempt re-identification, and (b) prior written notice has been given to the LEA who has provided prior written consent for such transfer.~~ Prior to publishing any document that names the LEA explicitly or indirectly, the Provider shall obtain the LEA’s written approval of the manner in which de-identified data is presented.
- Page 7, Section 4, Data Breach. In the event of ~~a~~ a confirmed unauthorized release, disclosure or acquisition of Student Data that compromises the security, confidentiality or integrity of the Student Data maintained by the Provider the Provider shall provide notification to LEA within ~~seventy two (72) hours~~thirty (30) days of confirmation of the incident, unless notification within this time limit would disrupt investigation of the incident by law enforcement. In such an event, notification shall be made within a reasonable time after the incident. Provider shall follow the following process:

- Page 20, Section 10, Reimbursement of Expenses Associated with Security Breach. In the event of a Security Breach that is attributable to the Provider, the Provider shall reimburse and indemnify the LEA for ~~any and all costs and expenses~~ reasonable direct costs that the LEA incurs in investigating and remediating the Security Breach, without regard to any limitation of liability provision otherwise agreed to between Provider and LEA, including but not limited to costs and expenses associated with:
- Page 21, Section 11, Transfer or Deletion of Student Data. ~~The Provider shall review, on an annual basis, whether the Student Data it has received pursuant to the DPA continues to be needed for the purpose(s) of the Service Agreement and this DPA. If any of the Student Data is no longer needed for purposes of the Service Agreement and this DPA, the Provider will provide written notice to the LEA as to what Student Data is no longer needed.~~ The Provider will delete or transfer Student Data in readable form to the LEA, as directed by the LEA (which may be effectuated through Exhibit D of the DPA), within 30 calendar days if the LEA requests deletion or transfer of the Student Data and shall provide written confirmation to the LEA of such deletion or transfer. Upon termination of the Service Agreement between the Provider and LEA, Provider ~~shall conduct a final review of Student Data within 60 calendar days, will destroy PII as described in its Data Protection Addendum available: Provider's DPA which is available here <https://renaissance.widen.net/view/pdf/rtvix11tcw/US-Terms-of-Service-and-License---Exhibit-D---Personal-Data-Annex.pdf?t.download=true&u=zceria> and incorporated by reference, Provider's DPA will control.~~
- Page 21, Section 13, Subcontractors. By no later than (5) business days after the date of execution of the DPA, the Provider shall provide the LEA with a list of any subcontractors to whom Student Data may be disclosed or a link to a page on the Provider's website that clearly lists any and all subcontractors to whom Student Data may be disclosed. This list shall, at a minimum, be updated and provided to the LEA by the beginning of each fiscal year (July 1) and at the beginning of each calendar year (January 1). LEA agrees Provider's list of subcontractors available here <https://renaissance.widen.net/view/pdf/yvg6muiwxr/Vendors---Hosting-Data-Center.pdf?u=zceria> and incorporated by reference fulfills the requirements of paragraph 13.
- Page 22, Section 19, Data Storage. Where required by law, Provider shall store all Student Data shared under the DPA within the United States.

RENAISSANCE

Exhibit D Data Protection Addendum

1. **United States** With respect to Authorized Users in the United States, the following provisions shall apply:
 - 1.1 **Definitions**

As used in this Data Protection Addendum, Capitalized words have the meaning set forth in Exhibit A of the Terms of Service or as otherwise expressly defined in this Data Protection Addendum. The following terms have the meanings set forth below for purposes of this Data Protection Addendum.

"Data Protection Legislation" means applicable federal, state, local, and municipal laws and regulations in the United States that relate to the privacy, data protection or data security of Customer Personally Identifiable Information, including but not limited to, and to the extent applicable, the Children's Online Privacy Protection Act, 15 U.S.C. § 6501, *et seq.*, and its implementing regulations, 16 C.F.R. Part 312 (together, "COPPA") and the Family Educational Rights and Privacy Act, 20 U.S.C. § 1232g, and its implementing regulations, 34 C.F.R. Part 99 (together, "FERPA").

"Personally Identifiable Information" or "PII" means information about an Authorized User that can be used on its own or with other information to identify, contact, or locate a single individual that is provided to Renaissance in connection with providing the Products to the Customer including, but not limited to, the following:

 - Any information that can be used to identify an individual, such as full name and date of birth;
 - Any other information that is linked to an individual such as educational information.

For the avoidance of doubt, PII is a subset of Customer Data.

"Process, Processes, Processing" shall have the same meaning as set out in the applicable Data Protection Legislation or if no such meaning or concept exists, it shall be the means by which Renaissance collects, uses, stores, discloses, or transfers Customer PII.
 - 1.2 **Compliance with Laws.** Each Party shall comply with all Data Protection Legislation applicable to it in its respective Processing of Customer PII under the Agreement.
 - 1.3 **Notices and Consents.** Customer shall provide all notices and obtain all such consents required under applicable Data Protection Legislation from the Authorized Users (or such Authorized User's parent or guardian, as applicable) (a) to allow Renaissance to Process the Customer PII and as otherwise described in the Agreement and (b) for Renaissance to Process the Customer PII as described herein and in the Notice of Renaissance's Practices Relating to Children's Online Privacy located [here](#) (collectively, the "Notices and Consents"). Customer represents and warrants that it has obtained and will maintain the Notices and Consents for all Authorized Users through the entire term of the Agreement.
 - 1.4 **Details of Processing.** Renaissance's Notice of Renaissance's Practices Relating to Children's Online Privacy located [here](#) sets out certain information regarding Renaissance's Processing of Customer PII of children under 13. For the purposes of this DPA, the Processing activities described in Renaissance's Notice of Renaissance's Practices Relating to Children's Online Privacy also apply to Customer PII from Authorized Users of all ages. Customer acknowledges and agrees that Renaissance's Notice of Renaissance's Practices Relating to Children's Online Privacy, including the Categories of Data Collected by Products available [here](#) is subject to change from time to time to remain current. Renaissance will not make material changes to the Notice of Renaissance's Practices Relating to Children's Online Privacy without prior notice to Customer.
 - 1.5 **Renaissance Obligations.**
 - a. Renaissance shall implement, maintain, and use reasonable technical and organizational measures that are designed to preserve the confidentiality and availability of all Customer PII Processed by Renaissance via the Products. Renaissance's technical and organizational measures, as set forth in Renaissance's Information Security Overview, are available upon request. Customer has reviewed such measures and agrees that the measures are appropriate taking into account the state of the art, the costs of implementation, nature, scope, context and purposes of the processing of Customer PII hereunder.
 - b. Renaissance shall take reasonable steps to ensure the reliability and integrity of any employees who have access to the Customer PII and ensure that employees are under a duty of confidentiality with respect to their Processing of the Customer PII.
 - c. Renaissance engages certain third-party entities to Process the Customer Data on Renaissance's behalf ("Sub-processors"). Renaissance shall enter into a written contract with each Sub-processor containing terms that offer substantially similar levels of data protection obligations and protection for Customer PII as those set out in this Section. Renaissance shall be liable for all acts and omissions of any Sub-processor to the extent Renaissance would be if they were Renaissance's acts or omissions. Customer consents to Renaissance engaging the Sub-

processors for the purposes set forth in the Agreement. Customer acknowledges and agrees that the list of Sub-processors available [here](#) may be updated from time to time. Renaissance shall make reasonable effort to inform Customer of any changes to the Sub-processors by posting updates on its privacy hub available [here](#).

- d. If Renaissance becomes aware of a confirmed breach of security leading to the accidental or unlawful destruction, loss, alteration, unauthorized disclosure of, or access to the Customer PII (a "Security Incident"), Renaissance shall inform Customer, within a reasonable amount of time, taking into account the timescales required by Data Protection Legislation, with respect to the Security Incident. Renaissance will provide reasonable information, cooperation, and updates of material developments to enable Customer to fulfill any data breach reporting obligations it may have under Data Protection Legislation. However, Renaissance's provision of information and cooperation shall be at Customer's cost and expense to the extent any Security Incidents were caused by Customer or its Authorized Users. Renaissance may take such other measures as it deems appropriate to mitigate the effects of the Security Incident.

- 1.6 Data Subject Inquiries. Customer shall be solely responsible for responding to and fulfilling any inquiries from Authorized Users and other data subjects (collectively, "Data Subjects") regarding their PII in connection with the Processing under this Agreement, including any requests to exercise their rights under applicable Data Protection Legislation, and Customer shall handle all Data Subject's inquiries in accordance with applicable Data Protection Legislation. Customer understands that Renaissance is not required to take any action in response to any requests from Data Subjects except to notify such Data Subjects to contact Customer. Authorized Users may review, obtain a copy of, and amend their own PII by contacting the Customer and following the Customer's procedures for amending PII. To the extent the Customer cannot obtain a copy of, delete, or amend the Customer PII directly within the Product, the Customer may contact Renaissance and Renaissance will provide a copy of, delete, or amend such Data Subject's PII in accordance with Customer's instructions. To the extent Customer is unable to directly service the Data Subject's request via functionality within the Products, and to the extent legally permitted, Customer shall be responsible for reasonable costs arising out of Renaissance's provision of assistance with Customer's Data Subject request. Customer shall indemnify, defend, and hold harmless Renaissance and its affiliates, subsidiaries, successors and assigns (and

the officers, directors, employees, sublicensees, customers, and agents of Renaissance and its affiliates, subsidiaries, successors, and assigns), from and against any and all losses, demands, liabilities, damages, fines, settlements, expenses, and costs (including without limitation reasonable attorneys' fees and costs), arising from, in connection with, Renaissance complying with Customer's instructions under this Agreement.

- 1.7 Authorized Disclosure of Customer PII.

- a. At the request of Customer, Customer acknowledges and agrees that Renaissance may provide Customer PII, to Third-Party Services or other entities to whom Customer requests Renaissance to provide Customer PII (e.g., State Board of Education). Customer shall make such a request to disclose Customer PII either (i) in writing; or (ii) via the Administrator Account (to the extent the functionality exists within the Product) by enabling the data sharing feature from within the Products (each an "Authorization"). Customer acknowledges and agrees that each Authorization will result in Customer electing, in its sole discretion, to transfer the Customer PII to the recipients that Customer selects ("Third-Party Services Recipients").
- b. Customer warrants that an individual assigned to the Administrator Account shall be an individual or individuals elected by Customer to have sufficient authority to authorize the transfer of Customer PII to the Third-Party Services Recipients on behalf of the Customer.
- c. Customer acknowledges that Customer Data may contain PII and may be subject to Data Protection Legislation. Customer will hold Renaissance harmless, and not liable in any way for disclosure of PII to the Third-Party Services Recipients under the terms of the Agreement.
- d. Renaissance makes no warranty (a) that the use of the Customer PII by the Recipient is valid and in compliance with all applicable Data Protection Legislation and Customer's organization's policies or (b) that Customer PII will remain secure upon transfer to the Recipient and disclaims any responsibility for the transfer. Customer acknowledges that the Customer Data will be provided on as "as is", "as available" basis.

- 1.8 Data Retention. Customer PII will be deleted within a reasonable amount of time after the data is no longer needed for the purpose for which it was collected, except that Renaissance may retain Customer PII as required by applicable legal requirements or as agreed by Customer.

- 1.9 Renaissance Data. Customer acknowledges and agrees that Renaissance may create Renaissance Data. In generating Renaissance Data, Renaissance shall (a) take reasonable measures to ensure that such information

cannot be associated with an Authorized User or a "consumer" or "household" (as defined in Data Protection Legislation), (b) publicly commit to maintain and use the information in deidentified form, and (c) not attempt to reidentify the information, except as permitted under Data Protection Legislation.

1.10 Education Records. As applicable, to the extent Renaissance has access to "Education Records" and "Personally Identifiable Information" (as those terms are defined in FERPA in connection with its provision of the Products: (a) Customer agrees that Renaissance has met the criteria for being a "School Official" with "Legitimate Educational Interests" (as those terms are used in FERPA) in such Education Records and Personally Identifiable Information; and (b) Renaissance agrees that such Education Records and Personally Identifiable Information will be used only for authorized purposes under the Agreement, and it will not redisclose such Education Records or Personally Identifiable Information except with Authorization from Customer and where such redisclosure is otherwise permitted under FERPA.

1.11 Personal Information Collected from Children. To the extent Renaissance collects Personal Information from a child under 13 in connection with its provision of the Products, (a) Renaissance agrees to limit its use of such Personal Information to the purposes authorized by Customer under the Agreement, and (b) Customer consents on behalf of parents or legal guardians to the collection, use, and disclosure of such Personal Information with respect to use of the Products as described in Renaissance's Notice of Renaissance's

Practices Relating to Children's Online Privacy located [here](#).

1.12 State Specific Privacy Addenda. If applicable, the parties agree to the [State Specific Data Protection Addenda](#) for the applicable state(s).

1.13 Updates to this DPA. Notwithstanding anything to the contrary in the Agreement, Renaissance reserves the right to modify this DPA from time to time in its sole discretion and without Customer's prior consent ("**Updated DPA**"); provided, where required by applicable law, Renaissance shall obtain Customer's consent to the Updated DPA. Customer agrees that any Updated DPA will be effective immediately upon Renaissance posting such Updated DPA on the privacy hub, unless Renaissance is required by applicable law to obtain Customer's consent, in which case, such Updated DPA will be effective immediately upon the provision of such consent. Renaissance will also endeavor to notify Customer of any material revision to this DPA at least 10 days prior to such revision coming into effect, using Customer's email address as set forth in the Quote.

2. **European Economic Area ("EEA") and United Kingdom ("UK")**. With respect to Authorized Users located in the EEA or the UK, the "EEA/UK" section of the [Global DPA](#) shall apply.

3. **Other Countries**. With respect to Authorized Users located outside of the United States, EEA or UK, the "Other Countries" section of the [Global DPA](#) shall apply.

RENAISSANCE

Categories of Data collected by Assessment Products:

Data Category	Data Elements	DnA	Fastbridge	myIGDIs	SchoolCity	StarPhonics	Star Assessment	Star Early Literacy
Application Technology Metadata	IP addresses of users; Use of cookies, etc.	Required	Required		Required	Required	Required	Required
	Other application technology metadata		Required	Required	Required	Required	Required	Required
Application Use Statistics	Metadata on user interaction with application	Required	Required	Required	Required	Required	Required	Required
Assessment	Standardized test scores	Optional			Optional		Optional	
	Observation data		Optional	Required	Optional	Optional	Optional (Star CBM-US Only)	
	Testing environment				Required		Required (US) Optional (UK)	Required (US) Optional (UK)
	Voice Recordings				Optional		Optional (Star CBM-US Only)	
	Other assessment data	Optional			Optional		Optional (Star CBM-US Only)	
Attendance	Student school (daily) attendance data	Optional						
	Student class attendance data	Optional		Optional				
Communication	Online communications that are captured (emails, blog entries)							

Data Category	Data Elements	DnA	Fastbridge	myIGDIs	SchoolCity	StarPhonics	Star Assessment	Star Early Literacy
Demographics	Conduct or behavioral data	Optional	Optional (SAEBRS & mySAEBRS)					
	Date of Birth	Required	Optional	Required	Required		Optional	Required
	Place of Birth	Optional						
	Gender	Required	Optional	Required	Optional		Optional	Optional
	Ethnicity or race	Optional	Optional	Optional	Optional		Optional	Optional
	Specialized education services (IEP or 504)	Optional	Optional	Optional	Optional		Optional	Optional
	Living situations (homeless/foster care)	Optional			Optional		Optional	Optional
	Language information (native, preferred or primary language spoken by student)	Optional	Optional	Optional	Optional		Optional	Optional
	Other indicator information	Optional			Optional			
Enrollment	Student school enrollment	Required	Required	Required	Required	Required	Required	Required
	Student grade level	Required	Required	Optional	Required	Required	Required	Required
	Homeroom			Required				
	Guidance counselor							
	Specific curriculum programs	Optional						

Data Category	Data Elements	DnA	Fastbridge	myIGDIs	SchoolCity	StarPhonics	Star Assessment	Star Early Literacy
Enrollment	Year of graduation	Optional						
	Other enrollment information	Optional						
Parent/ Guardian Information	Address	Optional						
	Email	Optional			Required (For Parent Portal)		Optional	Optional
	Phone	Optional						
	First and/or Last	Optional			Required (For Parent Portal)			
Schedule	Student scheduled courses	Required			Required		Required	Required
	Teacher names	Required		Required	Required	Required	Required	Required
	Teacher emails	Optional		Required	Required	Required	Required	Required
Special Indicator	English language learner information	Optional	Optional	Optional	Optional	Optional	Optional	Optional
	Low income status- SES Free and Reduced	Optional	Optional	Optional	Optional		Optional	Optional
	Medical alerts/ health data	Optional						
	Student disability information	Optional	Optional	Optional	Optional		Optional	Optional
	Student technology needs: assistive technology & accommodations						Optional- US Only; Star Math; Star Reading; Star Reading K12	Optional

Data Category	Data Elements	DnA	Fastbridge	myIGDIs	SchoolCity	StarPhonics	Star Assessment	Star Early Literacy	
Student Contact Information	Address	Optional							
	Email	Optional							Required (for SSO)
	Phone	Optional							
Student Identifiers	Local (School district) ID number	Required	Optional	Required	Required	Required	Optional	Optional	
	Vendor/App assigned student ID number		Required	Required	Required		Required	Required	
	Student App username	Optional	Required		Required		Required	Required	
	Student app passwords encrypted only for SSO	Optional	Required		Optional		Required	Required	
	First and/or Last	Required	Required	Required	Required	Required	Required	Required	
Student In App Performance	Program/ Application performance (assessment performance)	Optional	Required	Required	Required	Required	Required	Required	
Student Survey Responses	Student responses to surveys or questionnaires	Optional		Required	Optional		Required	Required	
Student Work	Student generated content: writing, pictures, etc.	Optional			Optional				
	Other student work data				Optional				
Transcript	Student course grades	Optional							

Data Category	Data Elements	DnA	Fastbridge	myIGDIs	SchoolCity	StarPhonics	Star Assessment	Star Early Literacy
Transcript	Student course data	Optional						
	Student course grades/ performance scores	Optional						
	Other transcript data	Optional						
Transportation	Other transportation data							

Categories of Data collected by Data & Connection Products:

Data Category	Data Elements	EduCLIMBER	eSchoolData	Schoolzilla	Schoolzilla Starter
Application Technology Metadata	IP addresses of users; Use of cookies, etc.	Required	Required	Required	Required
	Other application technology metadata	Required	Required	Required	Required
Application Use Statistics	Metadata on user interaction with application	Required	Required	Required	Required
Assessment	Standardized test scores	Optional	Optional	Optional	
	Observation data	Optional	Optional	Optional	
	Testing environment				
	Voice Recordings				
	Other assessment data	Optional	Optional	Optional	
Attendance	Student school (daily) attendance data	Optional	Required	Optional	
	Student class attendance data	Optional	Required	Optional	
Communication	Online communications that are captured (emails, blog entries)		Optional		
Demographics	Conduct or behavioral data	Optional	Required	Optional	
	Date of Birth	Required	Required	Optional	Optional
	Place of Birth		Required	Optional	

Data Category	Data Elements	EduCLIMBER	eSchoolData	Schoolzilla	Schoolzilla Starter
Demographics	Gender	Required	Required	Optional	Optional
	Ethnicity or race	Required	Required	Optional	Optional
	Specialized education services (IEP or 504)	Optional	Required	Optional	Optional
	Living situations (homeless/foster care)	Optional	Required	Optional	Optional
	Language information (native, preferred or primary language spoken by student)	Optional	Required	Optional	Optional
	Other indicator information	Optional	Optional	Optional	
Enrollment	Student school enrollment	Required	Required	Required	Required
	Student grade level	Required	Required	Required	Required
	Homeroom	Required	Required	Optional	
	Guidance counselor	Optional	Required	Optional	
	Specific curriculum programs	Optional	Optional	Optional	
Enrollment	Year of graduation	Optional	Required	Optional	
	Other enrollment information		Required	Optional	
Parent/ Guardian Information	Address	Optional	Required	Optional	
	Email	Optional	Required	Optional	Optional
	Phone	Optional	Required	Optional	
	First and/or Last	Optional	Required	Optional	

Data Category	Data Elements	EduCLIMBER	eSchoolData	Schoolzilla	Schoolzilla Starter
Schedule	Student scheduled courses	Required	Required	Optional	Required
	Teacher names	Required	Required	Optional	Required
	Teacher emails	Optional	Required	Optional	Required
Special Indicator	English language learner information	Optional		Optional	Optional
	Low income status-SES Free and Reduced	Optional	Required	Optional	Optional
	Medical alerts/ health data		Optional		
	Student disability information	Optional	Required	Optional	Optional
	Student technology needs: assistive technology & accommodations				
Student Contact Information	Address	Optional	Required	Optional	
	Email	Optional	Optional	Optional	
	Phone	Optional	Optional	Optional	
Student Identifiers	Local (School district) ID number	Required	Required	Required	Optional
	Vendor/App assigned student ID number	Required	Required	Required	Required
	Student App username	Required	Required	Optional	
	Student app passwords encrypted only for SSO	Required	Required		Required
	First and/or Last	Required	Required	Required	Required

Data Category	Data Elements	EduCLIMBER	eSchoolData	Schoolzilla	Schoolzilla Starter
Student In App Performance	Program/ Application performance (assessment performance)	Optional	Optional		
Student Survey Responses	Student responses to surveys or questionnaires	Optional			
Student Work	Student generated content: writing, pictures, etc.	Optional	Optional		
	Other student work data	Optional	Optional		
Transcript	Student course grades	Optional	Required	Optional	
Transcript	Student course data	Required	Required	Optional	
	Student course grades/ performance scores	Optional	Required	Optional	
	Other transcript data			Optional	
Transportation	Other transportation data	Optional	Optional		

Categories of Data collected by Practice & Instruction Products:

Data Category	Data Elements	Accelerated Reader	Accelerated Math	myON	Freckle	Lalilo
Application Technology Metadata	IP addresses of users; Use of cookies, etc.	Required	Required	Required	Required	Required
	Other application technology metadata	Required	Required	Required	Required	Required
Application Use Statistics	Metadata on user interaction with application	Required	Required	Required	Required	Required
Assessment	Standardized test scores				Optional	
	Observation data					
	Testing environment					
	Voice Recordings			Optional		Optional
	Other assessment data			Optional	Optional	
Attendance	Student school (daily) attendance data					
	Student class attendance data					
Communication	Online communications that are captured (emails, blog entries)			Optional		
Demographics	Conduct or behavioral data					
	Date of Birth	Optional (US) Required (UK)	Optional			
	Place of Birth					

Data Category	Data Elements	Accelerated Reader	Accelerated Math	myON	Freckle	Lalilo
Demographics	Gender	Optional	Optional			
	Ethnicity or race	Optional	Optional			
	Specialized education services (IEP or 504)	Optional	Optional			
	Living situations (homeless/foster care)	Optional	Optional			
	Language information (native, preferred or primary language spoken by student)	Optional	Optional		Required	Optional
	Other indicator information					
Enrollment	Student school enrollment	Required	Required	Required	Required	Required
	Student grade level	Required	Required	Required	Required	Required
	Homeroom					Required
	Guidance counselor					
	Specific curriculum programs					
Enrollment	Year of graduation					
	Other enrollment information					
Parent/ Guardian Information	Address					
	Email	Optional	Optional			Optional
	Phone					
	First and/or Last	Optional				

Data Category	Data Elements	Accelerated Reader	Accelerated Math	myON	Freckle	Lalilo
Schedule	Student scheduled courses	Required	Required			Required
	Teacher names	Required	Required	Required	Required	Required
	Teacher emails	Required	Required	Required	Required	Required
Special Indicator	English language learner information	Optional	Optional			
	Low income status-SES Free and Reduced	Optional	Optional			
	Medical alerts/ health data					
	Student disability information	Optional	Optional			
	Student technology needs: assistive technology & accommodations					
Student Contact Information	Address					
	Email					
	Phone					
Student Identifiers	Local (School district) ID number	Optional	Optional	Required	Optional	Optional
	Vendor/App assigned student ID number	Required	Required	Required		Required
	Student App username	Required	Required	Required		Required
	Student app passwords encrypted only for SSO	Required	Required	Required		Required
	First and/or Last	Required	Required	Required	Required	Required

Data Category	Data Elements	Accelerated Reader	Accelerated Math	myON	Freckle	Lalilo		
Student In App Performance	Program/ Application performance (assessment performance)	Required	Required	Required	Required	Required		
Student Survey Responses	Student responses to surveys or questionnaires	Required	Required	Optional	Required			
Student Work	Student generated content: writing, pictures, etc.			Optional	Optional			
	Other student work data							
Transcript	Student course grades							
Transcript	Student course data							
	Student course grades/ performance scores							
	Other transcript data							
Transportation	Other transportation data							

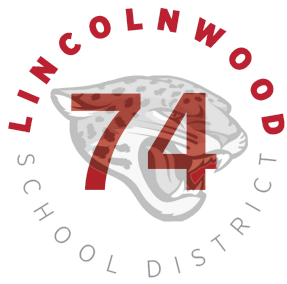

DATE: June 1, 2023

TOPIC: Increase Contingency Amount for Summer 2023 General Work

PREPARED BY: Courtney Whited

Recommended for:

- Action
- Discussion
- Information

Purpose/Background:

Unforeseen circumstances related to the purchase of replacement exhaust fans within the Summer 2023 General Work project recently developed. The original contingency amount was \$100,000. A previous allowance authorization was approved to install playground equipment this summer in the amount of \$58,176. In order to maintain sufficient contingency funds before construction commences, the Administration recommends a \$60,000 contingency increase. Any unused portion of the contingency funds will be returned to the District after project completion.

Fiscal Impact:

\$60,000 addition to the existing \$100,000 contingency allowance

Recommendation:

The Administration recommends that the Board of Education approve a contract change order in the amount of \$60,000 for additional contingency allowance funds related to the Summer 2023 General Work project to be performed by Bear Construction Company.



AIA® Document G701® – 2017

Change Order

PROJECT: *(Name and address)*
Lincolnwood SD 74
2023 General Work
Project No. 22066

CONTRACT INFORMATION:
Contract For: General Construction
Date: January 24, 2023

CHANGE ORDER INFORMATION:
Change Order Number: 002
Date: May 25, 2023

OWNER: *(Name and address)*
Lincolnwood School District 74
6950 N. East Prairie Road
Lincolnwood, IL 60712

ARCHITECT: *(Name and address)*
Studio GC, Inc.
223 W. Jackson Blvd., Suite 1200
Chicago, IL 60606

CONTRACTOR: *(Name and address)*
Bear Construction
150 Rohlwing Road
Rolling Meadows, IL 60008-1336

THE CONTRACT IS CHANGED AS FOLLOWS:

(Insert a detailed description of the change and, if applicable, attach or reference specific exhibits. Also include agreed upon adjustments attributable to executed Construction Change Directives.)

Add \$60,000 to Contingency Allowance.

TOTAL: \$60,000

The original Contract Sum was	\$ 1,415,600.00
The net change by previously authorized Change Orders	\$ 19,811.22
The Contract Sum prior to this Change Order was	\$ 1,435,411.22
The Contract Sum will be increased by this Change Order in the amount of	\$ 60,000.00
The new Contract Sum including this Change Order will be	\$ 1,495,411.22

The Contract Time will be unchanged by Zero (0) days.
The new date of Substantial Completion will be

NOTE: This Change Order does not include adjustments to the Contract Sum or Guaranteed Maximum Price, or the Contract Time, that have been authorized by Construction Change Directive until the cost and time have been agreed upon by both the Owner and Contractor, in which case a Change Order is executed to supersede the Construction Change Directive.

NOT VALID UNTIL SIGNED BY THE ARCHITECT, CONTRACTOR AND OWNER.

StudioGC, Inc.

ARCHITECT *(Firm name)*

Bear Construction

CONTRACTOR *(Firm name)*

Lincolnwood School District 74

OWNER *(Firm name)*

SIGNATURE

SIGNATURE

SIGNATURE

Athi Toufexis, Project Manager

PRINTED NAME AND TITLE

Victor Senese, Project Executive

PRINTED NAME AND TITLE

Kevin Daly, Board President

PRINTED NAME AND TITLE

05/25/2023

DATE

DATE

DATE

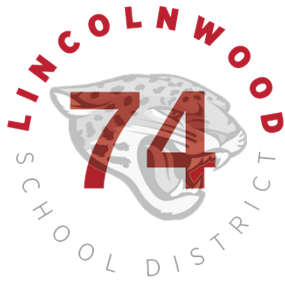

Executive Summary
Board of Education Meeting

DATE: June 1, 2023

TOPIC: Lincoln Hall's Mechanized Basketball Hoops

PREPARED BY: Courtney Whited

Recommended for:

- Action
- Discussion
- Information

Purpose/Background:

The Board of Education approves expenditures over \$10,000.

The auxiliary baskets at Lincoln Hall are dated and showing their age. The main baskets cannot be raised, which can become an obstacle during volleyball matches. \$37,500 of the Berger Family Foundation's donation was allocated for athletic venue improvements, specifically at Lincoln Hall.

Fiscal Impact:

\$57,251.70 H2I for Material, Freight, Demo, Installation, Dumpster (Exclude Floor Protection/below)
\$ 19,811.22 Bear Construction as a Change Order to Summer 2023 General Work for electrical work
=====

\$ 77,062.92 (\$39,562.92 paid using local funds & \$37,500 using Berger Family Foundation funds)

Recommendation:

The Facilities Committee members in attendance stated their support with the Administration to recommend to the Board of Education to accept the proposals from H2I and Bear Construction for materials & services related to improving Lincoln Hall's Basketball Hoops in the amount of \$77,062.92 for a summer 2023 installation.



H2I Group
157 Eisenhower Lane North
Lombard, IL 60148

Quote # 103651 SOURCEWELL

TO:
Attn:

Date: 2/13/23
Project: Lincoln Hall School
Location: Lincolnwood, IL
Architect: na
Addendum: na

Bid Date:

We propose to furnish the following as manufactured by Porter Athletic, Action Flooring, Irwin Seating or List Industries using standard design, materials, construction sizes and colors.

SOURCEWELL - Lincoln Hall School			
Item	Qty.	NJPA Pricing EA	Total NJPA Pricing
917 Forward Fold Backstop	2	\$6,176.24	\$12,352.48
949 Forward Fold Backstop	2	\$6,314.71	\$12,629.42
4' Cradle Structure for 949 Backstops	2	\$2,824.80	\$5,649.60
208 Regulation Glass Backboard	4	\$988.00	\$3,952.00
326 Backboard Pad	4	\$235.60	\$942.40
236154 PowrFlexII Goal	4	\$281.20	\$1,124.80
Safety Strap	4	\$627.00	\$2,508.00
PowrTouch2.5 Keypad	1	\$1,372.75	\$1,372.75
PowrTouch Relay Panels	1	\$1,420.25	\$1,420.25
Ceiling Suspended Backstop Installation	4	\$3,200.00	\$12,800.00
Demo Existing (4) Ceiling Suspended Backstops	4	\$800.00	\$3,200.00
Field Check	1	\$600.00	\$600.00
Unload Of Equipment	1	\$1,000.00	\$1,000.00
Freight	1	\$1,000.00	\$1,000.00
Total			\$60,551.70
H2i and Porter Additional Discounting			\$4,500.00
		Total	\$56,051.70

Material, Freight, Demo and Install \$56,051.70

ADD for Dumpster \$1,200.00

ADD for Floor Protection \$1,000.00

**ADD DUMPSTER
BUT EXCLUDE FLOOR
PROTECTION BECAUSE
BEAR CONSTRUCTION WILL
PROVIDE IT**



100% Employee Owned and Driven

Solutions for Industry, Education, and Healthcare Since 1924



Qualifications:

1. Due to the unsettled nature of "Steel Tariffs" and "Freight Regulations", any such surcharges are not included in this proposal. Any steel or freight surcharges incurred will be passed along to the customer.
2. We reserve our right to a schedule extension; change orders for additional costs (including but not limited to material escalation; labor rate increases; acceleration costs; shipping costs; storage costs; administration overhead; etc.) related to any occurrence of an event which is outside of our reasonable control and which prevents us from performing our obligations (Examples but not limited to: acts of God; strikes or other labor disturbances; delays in transportation; war; acts of terrorism; epidemics (such as COVID-19); etc.).
3. If gym is on second floor or our lift cannot access the gym there will be an additional charge for scaffolding use.
4. Quote does not include floor protection, if floor protection is needed there will be an additional charge.
5. Quote does not include demo or removal of existing equipment or obstructions.
6. Quote does not include ANY electric work, ALL electric by others.
7. Quote does not include ANY furring, if furring is needed, or other modifications to the wall, to install padding there will be an additional charge.

Excludes:

1. State Sales & Use Taxes. Purchaser by acceptance of this quotation agrees to furnish Tax Exemption Certificates when requested on non-taxable materials.
2. Charges for vertical transportation, Mechanical utilities and connections, Electrical utilities and connections, Bonds, Removal of existing equipment, Traps, Ducts, Fume hood fan/blowers, Rubber/vinyl base, Liquidated damages. Note: Clean-up to be limited to removing all debris, dirt and rubbish accumulated as a result of our installation to a dumpster provided by others, leaving the premises broom clean and orderly.
3. 50% Down payment is required for new customers and or private facilities
4. Payments Made by Credit Cards Are Subject To A 3% Processing Fee
5. Purchase Order Number Required

SEE & SIGN PAGE 2 for Terms & Conditions

This proposal is based upon usage of the AGC/ASA/ASC "Standard Form Construction Subcontract", 1996 Edition or a subcontract form otherwise acceptable to H2I Group, Inc.

TERMS: Net 30 Days

ACCEPTED: Company _____

RESPECTFULLY,

Name _____

H2I Group

Date _____

By  _____

PURCHASE ORDER # _____

Eric Shrigley

Note: This quotation is offered for acceptance within 30 days and is subject to revision beyond that time.

H2I Group Inc. Terms and Conditions

General



100% Employee Owned and Driven

Solutions for Industry, Education, and Healthcare Since 1924

335

Phone: (612) 331-8816
 Fax: (612) 331-4884
 Toll Free: (888) 239-8747
 Email: info@h2igroup.com
 Website: www.h2igroup.com

Serving all 50 states, Offices located:

Atlanta|Austin|Baltimore|Chicago|Cedar Falls|Columbia|Dallas|Denver|Des Moines|Grand Forks|Kansas City|Houston|Madison|Minneapolis|Omaha|Salt Lake City|Tampa



These terms and conditions are a component part of the attached proposal and constitute the entire agreement between H2I Group Inc. (hereinafter H2I). By signing the proposal, Customer acknowledges that they understand and accept the proposal and the following terms and conditions. All work shall be done in accordance with the attached proposal unless otherwise provided for in writing and signed by H2I.

Site Conditions

A smooth, level and clean sub-floor shall be provided or as required by H2I. Maintain environment at proper temperature (55-80 degrees F.) and humidity (35-50%) before, during and 30 days following installation.

Acceptance

This proposal may be accepted within 30 days subject to credit approval. H2I reserves the right to revoke this offer prior to acceptance by customer. Customer agrees that, by signing, grant authority to credit bureaus to release credit history information for the purpose of establishing credit with H2I and its subsidiaries.

Installation

This proposal assumes unloading and elevator use shall be conducted during normal business hours. This proposal is based on completing the work during normal business hours. Overtime, evening and weekend work is available at additional charge.

Engineering

All engineering, proposal drawings, specifications shall represent H2I's investment in engineering skill and development and remain the property of H2I. Such are submitted with the understanding that the information will not be disclosed or used in any way detrimental to H2I's interests.

Changes

Any requests for changes to the scope of work shall be made in writing with signed acceptance by authorized personnel from H2I and Customer.

Liability

H2I shall not be liable for damages in any form or any other claim arising out of strikes, floods, fire, accidents, or any other causes beyond our control. H2I shall not be liable for liquidated, consequential or any other damages or penalties of any kind for delays in completion of work.

Payment

Payment in full will be due and payable thirty (30) days from invoice date. Customer agrees to pay progress-billing invoices during the course of the project reflecting partial shipment of material and/or partial completion of labor work performed.

Customer agrees that, if the billed amount is not paid within terms, a service charge will be charged on the overdue balance at a percentage rate of 1.5% (18% ANNUAL PERCENTAGE RATE) for all accounts. If the customer fails to pay the entire unpaid balance on the account when due H2I may without further notice or demand, exercise all rights and remedies available by law for the collection of the balance due on the account.

Disputes

Customer and H2I hereby agree that disputes between the parties which cannot be settled amicably, shall be settled through the State District Court of Minnesota.

Cancellation

An officer of H2I must approve cancellation requests in writing. In order to compensate H2I for its investment in engineering, time, processing and administrative work, approved cancellations shall be subject to cancellation charge of 25% of the contract amount plus the cost of materials produced or in production, labor or other services performed, freight, taxes and any other out of pocket expenses incurred by H2I.

Warranty

THE MANUFACTURER EXPRESS WARRANTY IS PROVIDED IN LIEU OF ALL OTHER WARRANTIES, EXPRESS OR IMPLIED. THE WARRANTIES OF MERCHANTABILITY AND FITNESS FOR A PARTICULAR PURPOSE ARE HEREBY DISCLAIMED BY H2I.

Insurance

H2I maintains insurance and will provide certificates of insurance if requested on coverage and limits as provided by its insurance policy. No other insurance coverage is provided including waiver of subrogation or additional named insureds.

Codes

Customer, architect and/or contractor shall be responsible for all local, state and federal agency code compliance, permits, fees, design, engineering and testing. H2I does not provide professional liability or pollution insurance for any of these services. Costs for any and all such services are not included in this proposal.

Signature: _____ Name: _____ Date: _____
(Please Print)



100% Employee Owned and Driven

Solutions for Industry, Education, and Healthcare Since 1924



AIA®

Document G701® – 2017

Change Order

PROJECT: *(Name and address)*
Lincolnwood SD 74
2023 General Work
Project No. 22066

CONTRACT INFORMATION:
Contract For: General Construction
Date: January 24, 2023

CHANGE ORDER INFORMATION:
Change Order Number: 001
Date: May 9, 2023

OWNER: *(Name and address)*
Lincolnwood School District 74
6950 N. East Prairie Road
Lincolnwood, IL 60712

ARCHITECT: *(Name and address)*
Studio GC, Inc.
223 W. Jackson Blvd., Suite 1200
Chicago, IL 60606

CONTRACTOR: *(Name and address)*
Bear Construction
150 Rohlwing Road
Rolling Meadows, IL 60008-1336

THE CONTRACT IS CHANGED AS FOLLOWS:

(Insert a detailed description of the change and, if applicable, attach or reference specific exhibits. Also include agreed upon adjustments attributable to executed Construction Change Directives.)

PCO - 002: Electrical work for Lincoln Hall basketball hoop upgrades: \$19,811.22

TOTAL: \$19,811.22

The original Contract Sum was	\$ 1,415,600.00
The net change by previously authorized Change Orders	\$ 0.00
The Contract Sum prior to this Change Order was	\$ 1,415,600.00
The Contract Sum will be increased by this Change Order in the amount of	\$ 19,811.22
The new Contract Sum including this Change Order will be	\$ 1,435,411.22

The Contract Time will be unchanged by Zero (0) days.
The new date of Substantial Completion will be

NOTE: This Change Order does not include adjustments to the Contract Sum or Guaranteed Maximum Price, or the Contract Time, that have been authorized by Construction Change Directive until the cost and time have been agreed upon by both the Owner and Contractor, in which case a Change Order is executed to supersede the Construction Change Directive.

NOT VALID UNTIL SIGNED BY THE ARCHITECT, CONTRACTOR AND OWNER.

Studio GC, Inc.

ARCHITECT *(Firm name)*

Bear Construction

CONTRACTOR *(Firm name)*

Lincolnwood School District 74

OWNER *(Firm name)*



SIGNATURE

SIGNATURE

SIGNATURE

Athi Toufexis, Project Manager

PRINTED NAME AND TITLE

PRINTED NAME AND TITLE

Kevin Daly, Board President

PRINTED NAME AND TITLE

May 9, 2023

DATE

DATE

DATE



To: Studio GC
Attn: Athi Toufexis
Date: May 8, 2023

PCO - 002

From: BEAR Construction Company
Project Name: Lincolnwood SD 74 2023 General Work
Architect: Studio GC
Architect Project #:
Owner: Lincolnwood School District 74

PCO SUMMARY: Basketball Hoop Electrical

Trade	Contractor	Description	Totals
Electrical	SRC Electric	Electrical circuits for new basketball hoops	\$ 12,650.00
General Conditions	Bear Construction	Floor Protection	\$ 1,500.00
Painting	Celtic Commercial Painting	Painting of conduit and ceiling patching	\$ 3,500.00
			\$ -
			\$ -
			\$ -
			\$ -
			\$ -
			\$ -
			\$ -

Total Contractor Cost: \$ 17,650.00
Bond: \$ 198.11
Insurance: \$ 198.11
Markup 10%: \$ 1,765.00
Total Change Order Request: \$ 19,811.22

Potential Schedule Impact: No
The contract completion time shall be extended by: 0 Days

Dan Zivilik
BEAR Construction Company

5/8/2023
Date Approved

Lincolnwood School District 74

Date Approved

Studio GC

Date Approved

5.8.2023

Dan Zivilik
Bear Construction Company
1501 Rohlwing Road, Rolling Meadows, IL, 60008

RE: Lincolnwood School district- Basketball hoop motor/controls

We are pleased to quote the necessary electrical labor and material to complete the following scope of work:

- All selective demolition of (2) existing basket ball hoop connections and make safe during construction/new installation
- Extend all necessary conduit and wiring for (2) existing basketball hoops. If needed, extend and install new twist lock receptacle with Garvin to be within 6' of new motor.
- Furnish and install new conduit from E-closet panel as indicated, run new conduit the entire gym length floor off to one side to avoid the middle. Pull proper sized dedicated conductors to run the (2) main basketball hoops. Furnish 1900 with twist lock receptacle within 6' connection point of the motor as indicated per the specs.
- All necessary conduit for main controller to operate load side motors for key pad operation. Controller to be installed in location determined by AE/owner prior to install
- Furnish and install all necessary wiremold or surface mounted conduit to control new key pad to be installed to control operation of the (4) basketball hoop motors. All low voltage wiring from control panel to key pad to be furnished and installed as noted per spec detail
- SRC to provide new single pole 20-amp breakers as needed. We are under the impression that the panel has available space as noted per panel schedule
- All necessary wall cores/penetrations
- Fire seal all wall cores/penetrations
- Scissor lift
- Work to be completed during normal hours Mon-Fri 6am-2pm.

Our cost to complete the above scope of work is: \$12,650.00

**Please note quote is valid for 30 days from above date, material pricing is subject to change*

Notes/Exclusions:

- Permits/Fees
- Premium time
- Porter- key pad, motors, furnishing or installation
- Low voltage components

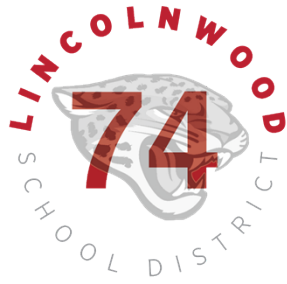

Executive Summary Board of Education Meeting

DATE: June 1, 2023

TOPIC: Tractor Purchase and Trade-In

PREPARED BY: Jim Caldwell

Recommended for:

- Action
- Discussion
- Information

Purpose/Background:

The District's 2010 John Deere tractor requires major engine work. Administration recommends trading in this failing equipment for a new Kubota tractor and attachments. The District Legal Counsel has reviewed this sales quote. The Sourcewell process does qualify as an alternative to the ordinary public bidding requirement in the School Code. Sourcewell is a purchasing cooperative, acceptable for school districts to purchase through under the Illinois Governmental Joint Purchasing Act (30 ILCS 525/0.01 et seq.). Although School Code Section 10-20.21 contains the general requirement for bidding of purchases over \$25,000, the Governmental Joint Purchasing Act specifies that it supersedes such other laws "when the governmental units are exercising the joint powers created by this Act." 30 ILCS 525/2(a).

In order to be in compliance, SD74 needs to be a member of Sourcewell and make its purchase through the Kubota contract that was previously bid on there. It appears that Russo is an authorized Kubota dealer and this purchase will be made subject to that Kubota Sourcewell contract.

Lincolnwood School District 74 is already a member of Sourcewell (ID# 15775).

Fiscal Impact:

\$42,194.20 New Kubota Tractor with Attachments

(\$8,000) Credit for SD74's John Deere Tractor + Attachments Trade In

\$34,194.20 Total

Recommendation:

The Facilities Committee members in attendance stated their support with the Administration to recommend to the Board of Education to accept this Sales Quote from Russo Power Equipment for a new Kubota tractor with attachments in the amount of \$34,194.20 along with a trade in of the District's John Deere tractor and attachments.



9525 W. Irving Park Road
 Schiller Park, IL 60176
 (847) 678-9525
 RussoPower.com

Sales Quote
SQ20014418



Bill-to

Lincolnwood School District 74
 6950 E Prairie Rd

 Lincolnwood, IL 60712
 United States

Ship-to

Lincolnwood School District 74
 6950 E Prairie Rd

 Lincolnwood, IL 60712
 United States

Sales Quote Details

Customer ID CUS10022043
Customer PO JCALDWELL@SD74.ORG
Sales Rep George Arroyo
Document Date 3/30/2023
Shipment Method
Terms CASH

Item No.	Description	Qty	List Price	Unit Price	Line Amount
BX2380RVKUB	4Wd Tra/Fold Rops/R4 Tire/Ldr Valve	1	17,170.00	17,170.00	17,170.00
BX5447KUB	Drift Cutters For 55" Snowblower	1	113.00	113.00	113.00
V5250KUB	Markers / For V5290, V5291 & V5260	1	49.00	49.00	49.00
BX8113KUB	Wheel Weight 50 Lb	2	123.00	123.00	246.00
BX2419KUB	Dual Rear Remote Valve Kit	1	371.00	371.00	371.00
BX2814AKUB	60" Front Sweeper	1	3,313.00	3,313.00	3,313.00
BX2813KUB	Rubber Cutting Edge For Bx2812	1	292.00	292.00	292.00
BX2812AKUB	60" Blade - Hyd. Angle	1	1,889.00	1,889.00	1,889.00
BX2817KUB	Hard Plastic Shoes And Cutting Edge For Bx2816	1	753.00	753.00	753.00
K9184KUB	32 Inch Pallet Forks For Bx Series	1	413.00	413.00	413.00
E1176KUB	Universal LED Light Kit	1	269.00	269.00	269.00
LA344SKUB	Front Loader W/ Guard & 2-Lever Quick Attach Bucke	1	4,145.00	4,145.00	4,145.00
BX4070AKUB	Drop on Cab for BX80 Series	1	7,174.00	7,174.00	7,174.00
B8160KUB	Ballast Box / 400Lbs. Dry Sand Capacity / Fits B,	1	290.00	290.00	290.00
BX2825KUB	Optional Skid Shoes For Bx2812	1	193.00	193.00	193.00
BX7330AKUB	Bx Single Work Light Kit	1	96.00	96.00	96.00
B2671KUB	Hydraulic Angulation Kit / B2672 , B2673	1	678.00	678.00	678.00
BX2412KUB	3Rd Function Valve Kit	1	818.00	818.00	818.00
BX2821AKUB	Hydraulic Chute Deflector Kit	1	1,401.00	1,401.00	1,401.00
BX2822AKUB	55" Two Stage Snow Blower	1	4,979.00	4,979.00	4,979.00
BX4077KUB	Cab Seal Kit	1	275.00	275.00	275.00
BX4075KUB	Rear Led Light Kit	1	242.00	242.00	242.00
BX4073KUB	Rear Wiper Kit For Cab	1	306.00	306.00	306.00
BX2811KUB	Mid Pto Driveline Kit For Bx2810	1	949.00	949.00	949.00
BX2810KUB	4-Point Front Quick Hitch	1	1,026.00	1,026.00	1,026.00



9525 W. Irving Park Road
 Schiller Park, IL 60176
 (847) 678-9525
 RussoPower.com

Sales Quote
SQ20014418



BX2415KUB	2-Lever Qa Pallet Fork Frame	1	776.00	776.00	776.00
SET-UP	Sourcewell Discount	1	150.00	(10,609.72)	(10,609.72)
SET-UP	Dealer Assembly	1	1,934.17	1,934.17	1,934.17
FREIGHTIN	Freight In	1	1,143.75	1,143.75	1,143.75
SET-UP	Kubota 2-Year Warranty	1	1,100.00	1,100.00	1,100.00
SET-UP	bdl	1	400.00	400.00	400.00
QUOTEITEM	John Deere Trade In Assesories	1	0.00	(8,000.00)	(8,000.00)

Bring toughness to turf with Bobcat's industry-leading Stand-On & Zero-Turn mowers! Deliver a perfect cut every time thanks to their innovative decks, agile designs, and relentless durability.

Prices reflected on this quote are valid for 7 days

Signature : _____



344

Subtotal	34,194.20
Tax	0.00
Total	34,194.20

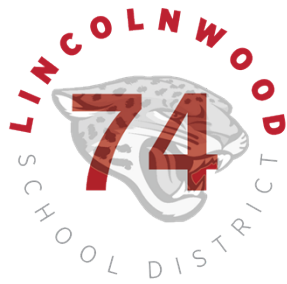

Executive Summary Board of Education Meeting

DATE: June 1, 2023

TOPIC: Window Treatments for Rutledge Hall's First Floor

PREPARED BY: Courtney Whited

Recommended for:

Action

Discussion

Information

Purpose/Background:

As cited on the Master Facilities Plan, window treatment installation at Rutledge Hall is scheduled for Summer 2023. The attached quote from Indecor lists the cost to install roller shades on first floor windows in Rutledge Hall. These would be the same roller shades that are currently mounted throughout Todd Hall to be aesthetically consistent.

Fiscal Impact:

\$22,350

Recommendation:

The Facilities Committee members in attendance stated their support with the Administration to recommend to the Board of Education to accept the quote from Indecor for window roller shade installations throughout the first floor of Rutledge Hall in the amount of \$22,350 during Summer 2023.

Customer

Indecor Inc.
8222 Lehigh Ave
Morton Grove, IL
60053, US
(773) 561-7670

Prepared By:
Adam Campisano
(312) 315-3784
adam@indecorinc.com

Lincolnwood School District 74
6950 E Prairie Rd
Lincolnwood, IL
60712, US

Jim Caldwell
(224) 636-3370
jcaldwell@sd74.org

Project: Rutledge Hall

Scope of Work

1st Floor

- 83 SWF Manual Clutch Roller Shades
- Standard Controls
 - Fabric: Crosshatch S300 (3% Open) Color: Fog
 - Includes White Fascia
 - Includes Non-Union Installation
 - Tax Exempt

Take-Down of Existing by Others

Notes

Summary

Subtotal \$ 22,350.00

\$ 22,350.00

Accepted By

Date

.....

Lincolnwood School District 74

Fund Balances

Fiscal Year: 2022-2023

Month: March
 Year: 2023
 Fund Type:

Include Cash Balance
 FY End Report

<u>Fund</u>	<u>Description</u>	<u>Beginning Balance</u>	<u>Revenue</u>	<u>Expense</u>	<u>Transfers</u>	<u>Fund Balance</u>
10	EDUCATIONAL	\$13,022,792.37	\$16,800,091.39	(\$14,110,496.58)	\$0.00	\$15,712,387.18
20	OPERATIONS & MAINTENANCE	\$3,494,768.89	\$1,842,278.08	(\$1,477,015.44)	\$0.00	\$3,860,031.53
30	DEBT SERVICE	\$829,925.65	\$1,260,942.42	(\$1,494,725.00)	\$0.00	\$596,143.07
40	TRANSPORTATION	\$1,442,825.96	\$1,266,085.29	(\$919,073.67)	\$0.00	\$1,789,837.58
50	MUNICIPAL RETIREMENT	\$0.00	\$0.00	\$0.00	\$0.00	\$0.00
51	IMRF	\$448,606.14	\$437,051.63	(\$153,232.74)	\$0.00	\$732,425.03
52	SOCIAL SECURITY AND MEDICARE	\$139,099.31	\$468,967.18	(\$245,265.57)	\$0.00	\$362,800.92
60	CAPITAL PROJECTS	\$5,825,261.89	\$657,524.03	(\$1,745,897.45)	\$0.00	\$4,736,888.47
70	WORKING CASH	\$573,446.40	\$6,961.86	\$0.00	\$0.00	\$580,408.26
80	TORT IMMUNITY	\$249,408.82	\$304,142.85	(\$24,612.00)	\$0.00	\$528,939.67
90	FIRE PREVENTION & SAFETY	\$2,617,556.88	\$409,212.44	(\$98,512.00)	\$0.00	\$2,928,257.32
99	LINCOLNWOOD SCHOOLS ACTIVITY FUN	\$0.00	\$0.00	\$0.00	\$0.00	\$0.00
Grand Total:		\$28,643,692.31	\$23,453,257.17	(\$20,268,830.45)	\$0.00	\$31,828,119.03

End of Report

Lincolnwood School District 74

Treasurers Report FUND- All Funds As of 03/31/2023

Fiscal Year: 2022-2023

ASSETS

CASH & INVESTMENTS

Cash in Bank (+)	\$31,274,474.60
Imprest Fund (+)	\$15,143.99
Petty Cash (+)	\$100.00

Sub-total : CASH & INVESTMENTS	\$31,289,718.59
--------------------------------	-----------------

DUE FROM OTHER GOVERNMENTS

Inter-Governmental Loans (+)	(\$467.03)
------------------------------	------------

Sub-total : DUE FROM OTHER GOVERNMENTS	(\$467.03)
--	------------

Total : ASSETS		\$31,289,251.56
----------------	--	-----------------

LIABILITIES

ACCOUNTS PAYABLE

Accounts Payable (+)	\$66,108.88
----------------------	-------------

Sub-total : ACCOUNTS PAYABLE	\$66,108.88
------------------------------	-------------

OTHER CURRENT LIABILITIES

Other Liabilities (+)	\$35,080.40
-----------------------	-------------

Payroll Liabilities (+)	(\$640,056.75)
-------------------------	----------------

Sub-total : OTHER CURRENT LIABILITIES	(\$604,976.35)
---------------------------------------	----------------

Total : LIABILITIES	(\$538,867.47)
---------------------	----------------

FUND BALANCE

Unreserved Fund Balance

Fund Balance (+)	\$28,643,692.31
------------------	-----------------

Sub-total : Unreserved Fund Balance	\$28,643,692.31
-------------------------------------	-----------------

NET INCREASE (DECREASE)

NET INCREASE (DECREASE) (+)	\$3,184,426.72
-----------------------------	----------------

Sub-total : NET INCREASE (DECREASE)	\$3,184,426.72
-------------------------------------	----------------

Total : FUND BALANCE	\$31,828,119.03
----------------------	-----------------

Total LIABILITIES + FUND BALANCE		\$31,289,251.56
----------------------------------	--	-----------------

End of Report

Lincolnwood School District 74

Treasurers Report FUND- All Funds For the Period 03/01/2023 through 03/31/2023

Fiscal Year: 2022-2023

	<u>03/01/2023 - 03/31/2023</u>	<u>Year To Date</u>	<u>Budget</u>	<u>Budget Balance</u>	
REVENUE					
LOCAL SOURCES					
Property Tax Receipts (+)	\$6,135,821.06	\$17,833,770.49	\$25,868,050.00	\$8,034,279.51	68.9%
Payments in Lieu of Taxes (+)	\$145,956.67	\$1,319,430.08	\$900,000.00	(\$419,430.08)	146.6%
Tuition Payments Received (+)	\$80,500.55	\$206,107.71	\$221,600.00	\$15,492.29	93.0%
Interest Revenue Received (+)	\$35,119.45	\$295,193.31	\$369,000.00	\$73,806.69	80.0%
Sales to Pupils & Adults (+)	\$20,689.15	\$165,602.56	\$200,000.00	\$34,397.44	82.8%
Activity Fees Received (+)	\$14,424.93	\$82,047.17	\$100,150.00	\$18,102.83	81.9%
Other Local Revenue (+)	\$7,981.69	\$173,024.49	\$330,430.00	\$157,405.51	52.4%
Rental Revenue (+)	\$15,885.57	\$78,598.43	\$89,600.00	\$11,001.57	87.7%
Sub-total : LOCAL SOURCES	\$6,456,379.07	\$20,153,774.24	\$28,078,830.00	\$7,925,055.76	71.8%
STATE SOURCES					
State Grants & Aid Received (+)	\$116,358.00	\$1,212,211.41	\$1,539,000.00	\$326,788.59	78.8%
Sub-total : STATE SOURCES	\$116,358.00	\$1,212,211.41	\$1,539,000.00	\$326,788.59	78.8%
FEDERAL SOURCES					
Federal Grants & Aid Received (+)	\$22,519.08	\$2,087,271.52	\$2,106,691.00	\$19,419.48	99.1%
Sub-total : FEDERAL SOURCES	\$22,519.08	\$2,087,271.52	\$2,106,691.00	\$19,419.48	99.1%
Total : REVENUE	\$6,595,256.15	\$23,453,257.17	\$31,724,521.00	\$8,271,263.83	73.9%
EXPENDITURES					
REGULAR K-12 PROGRAMS					
Salaries (-)	\$923,596.23	\$4,801,173.06	\$7,735,177.00	\$2,934,003.94	62.1%
Employee Benefits (-)	\$112,367.10	\$730,512.48	\$1,430,774.00	\$700,261.52	51.1%
Termination Benefits (-)	\$44,262.41	\$231,013.85	\$397,000.00	\$165,986.15	58.2%
Purchased Services (-)	\$9,028.15	\$129,771.93	\$216,005.00	\$86,233.07	60.1%
Supplies & Materials (-)	\$19,702.48	\$230,586.95	\$549,480.00	\$318,893.05	42.0%
Capital Expenditures (-)	\$26,416.40	\$109,238.18	\$204,000.00	\$94,761.82	53.5%
Other Objects (-)	\$0.00	\$225.00	\$1,800.00	\$1,575.00	12.5%
Non-Capitalized Equipment (-)	\$132.97	\$4,802.05	\$117,500.00	\$112,697.95	4.1%
Sub-total : REGULAR K-12 PROGRAMS	(\$1,135,505.74)	(\$6,237,323.50)	(\$10,651,736.00)	(\$4,414,412.50)	58.6%
PRE-K PROGRAMS					
Salaries (-)	\$27,399.96	\$146,133.12	\$225,356.00	\$79,222.88	64.8%
Employee Benefits (-)	\$7,936.48	\$44,450.57	\$69,413.00	\$24,962.43	64.0%
Supplies & Materials (-)	\$284.10	\$1,662.62	\$4,300.00	\$2,637.38	38.7%
Non-Capitalized Equipment (-)	\$0.00	\$194.02	\$750.00	\$555.98	25.9%
Sub-total : PRE-K PROGRAMS	(\$35,620.54)	(\$192,440.33)	(\$299,819.00)	(\$107,378.67)	64.2%
SPECIAL ED PROGRAMS K-12					
Salaries (-)	\$132,801.04	\$744,505.89	\$1,198,065.00	\$453,559.11	62.1%
Employee Benefits (-)	\$28,270.05	\$176,723.22	\$354,957.00	\$178,233.78	49.8%
Purchased Services (-)	\$380.00	\$535.75	\$600.00	\$64.25	89.3%
Supplies & Materials (-)	\$136.07	\$1,005.66	\$5,500.00	\$4,494.34	18.3%
Capital Expenditures (-)	\$0.00	\$2,338.09	\$6,000.00	\$3,661.91	39.0%
Other Objects (-)	\$0.00	\$180.00	\$200.00	\$20.00	90.0%
Non-Capital Equipment (-)	\$0.00	\$1,742.40	\$5,000.00	\$3,257.60	34.8%

Operating Statement with Budget

Lincolnwood School District 74

Treasurers Report FUND- All Funds For the Period 03/01/2023 through 03/31/2023

Fiscal Year: 2022-2023

	<u>03/01/2023 - 03/31/2023</u>	<u>Year To Date</u>	<u>Budget</u>	<u>Budget Balance</u>	
Sub-total : SPECIAL ED PROGRAMS K-12	(\$161,587.16)	(\$927,031.01)	(\$1,570,322.00)	(\$643,290.99)	59.0%
REMEDIAL & SUPPLEMENTAL K-12					
Salaries (-)	\$67,528.44	\$360,151.68	\$585,251.00	\$225,099.32	61.5%
Employee Benefits (-)	\$9,768.03	\$61,994.60	\$110,875.00	\$48,880.40	55.9%
Purchased Services (-)	\$0.00	\$41,999.55	\$56,795.00	\$14,795.45	73.9%
Supplies & Materials (-)	\$171.18	\$5,636.36	\$12,250.00	\$6,613.64	46.0%
Sub-total : REMEDIAL & SUPPLEMENTAL K-12	(\$77,467.65)	(\$469,782.19)	(\$765,171.00)	(\$295,388.81)	61.4%
INTERSCHOLASTIC PROGRAMS					
Salaries (-)	\$35,410.96	\$72,283.20	\$90,000.00	\$17,716.80	80.3%
Employee Benefits (-)	\$1,381.48	\$2,971.71	\$7,405.00	\$4,433.29	40.1%
Supplies & Materials (-)	\$157.96	\$6,886.70	\$5,500.00	(\$1,386.70)	125.2%
Capital Expenditures (-)	\$0.00	\$0.00	\$1,500.00	\$1,500.00	0.0%
Other Objects (-)	\$0.00	\$3,500.00	\$3,600.00	\$100.00	97.2%
Sub-total : INTERSCHOLASTIC PROGRAMS	(\$36,950.40)	(\$85,641.61)	(\$108,005.00)	(\$22,363.39)	79.3%
SUMMER SCHOOL PROGRAMS					
Salaries (-)	\$513.00	\$31,339.54	\$42,491.00	\$11,151.46	73.8%
Employee Benefits (-)	\$67.49	\$4,100.65	\$10,100.00	\$5,999.35	40.6%
Supplies & Materials (-)	\$148.98	\$1,709.61	\$3,117.00	\$1,407.39	54.8%
Sub-total : SUMMER SCHOOL PROGRAMS	(\$729.47)	(\$37,149.80)	(\$55,708.00)	(\$18,558.20)	66.7%
GIFTED PROGRAMS					
Salaries (-)	\$51,967.59	\$277,160.48	\$450,386.00	\$173,225.52	61.5%
Employee Benefits (-)	\$6,248.63	\$41,144.35	\$70,821.00	\$29,676.65	58.1%
Supplies & Materials (-)	\$50.00	\$3,070.22	\$4,250.00	\$1,179.78	72.2%
Sub-total : GIFTED PROGRAMS	(\$58,266.22)	(\$321,375.05)	(\$525,457.00)	(\$204,081.95)	61.2%
BILINGUAL PROGRAMS					
Salaries (-)	\$80,484.63	\$415,440.88	\$693,562.00	\$278,121.12	59.9%
Employee Benefits (-)	\$9,197.71	\$57,899.61	\$101,304.00	\$43,404.39	57.2%
Purchased Services (-)	\$0.00	\$0.00	\$1,800.00	\$1,800.00	0.0%
Supplies & Materials (-)	\$1,126.59	\$5,684.53	\$1,750.00	(\$3,934.53)	324.8%
Sub-total : BILINGUAL PROGRAMS	(\$90,808.93)	(\$479,025.02)	(\$798,416.00)	(\$319,390.98)	60.0%
ATTENDANCE & SOCIAL WORK					
Salaries (-)	\$46,629.57	\$248,691.04	\$404,123.00	\$155,431.96	61.5%
Employee Benefits (-)	\$4,147.21	\$26,699.85	\$41,196.00	\$14,496.15	64.8%
Supplies & Materials (-)	\$57.59	\$626.53	\$1,000.00	\$373.47	62.7%
Sub-total : ATTENDANCE & SOCIAL WORK	(\$50,834.37)	(\$276,017.42)	(\$446,319.00)	(\$170,301.58)	61.8%
GUIDANCE SERVICES					
Purchased Services (-)	\$0.00	\$0.00	\$5,000.00	\$5,000.00	0.0%
Sub-total : GUIDANCE SERVICES	\$0.00	\$0.00	(\$5,000.00)	(\$5,000.00)	0.0%
HEALTH SERVICES					

Operating Statement with Budget

Lincolnwood School District 74

Treasurers Report FUND- All Funds For the Period 03/01/2023 through 03/31/2023

Fiscal Year: 2022-2023

	<u>03/01/2023 - 03/31/2023</u>	<u>Year To Date</u>	<u>Budget</u>	<u>Budget Balance</u>	
Salaries (-)	\$22,295.27	\$123,685.26	\$159,352.00	\$35,666.74	77.6%
Employee Benefits (-)	\$8,412.17	\$47,280.87	\$65,795.00	\$18,514.13	71.9%
Purchased Services (-)	\$5,475.00	\$34,959.09	\$31,000.00	(\$3,959.09)	112.8%
Supplies & Materials (-)	\$300.43	\$4,404.75	\$5,300.00	\$895.25	83.1%
Capital Expenditures (-)	\$0.00	\$223.28	\$2,250.00	\$2,026.72	9.9%
Other Objects (-)	\$0.00	\$0.00	\$750.00	\$750.00	0.0%
Non-Capital Equipment (-)	\$0.00	\$0.00	\$1,600.00	\$1,600.00	0.0%
Sub-total : HEALTH SERVICES	(\$36,482.87)	(\$210,553.25)	(\$266,047.00)	(\$55,493.75)	79.1%
PSYCHOLOGICAL SERVICES					
Salaries (-)	\$20,721.24	\$110,513.28	\$179,584.00	\$69,070.72	61.5%
Employee Benefits (-)	\$3,270.28	\$21,859.79	\$37,804.00	\$15,944.21	57.8%
Purchased Services (-)	\$0.00	\$0.00	\$1,100.00	\$1,100.00	0.0%
Supplies & Materials (-)	\$0.00	\$1,272.59	\$1,850.00	\$577.41	68.8%
Sub-total : PSYCHOLOGICAL SERVICES	(\$23,991.52)	(\$133,645.66)	(\$220,338.00)	(\$86,692.34)	60.7%
SPEECH PATHOLOGY & AUDIOLOGY					
Salaries (-)	\$31,666.47	\$168,979.04	\$274,591.00	\$105,611.96	61.5%
Employee Benefits (-)	\$3,624.48	\$23,810.62	\$41,079.00	\$17,268.38	58.0%
Purchased Services (-)	\$0.00	\$443.16	\$360.00	(\$83.16)	123.1%
Supplies & Materials (-)	\$112.78	\$406.32	\$1,800.00	\$1,393.68	22.6%
Sub-total : SPEECH PATHOLOGY & AUDIOLOGY	(\$35,403.73)	(\$193,639.14)	(\$317,830.00)	(\$124,190.86)	60.9%
OTHER SUPPORT SERVICES - PUPILS					
Salaries (-)	\$12,041.95	\$47,101.39	\$101,000.00	\$53,898.61	46.6%
Employee Benefits (-)	\$759.09	\$2,984.97	\$9,732.00	\$6,747.03	30.7%
Sub-total : OTHER SUPPORT SERVICES - PUPILS	(\$12,801.04)	(\$50,086.36)	(\$110,732.00)	(\$60,645.64)	45.2%
IMPROVEMENT OF INSTRUCTION					
Salaries (-)	\$38,547.09	\$272,451.96	\$364,189.00	\$91,737.04	74.8%
Employee Benefits (-)	\$5,114.77	\$43,341.47	\$56,095.00	\$12,753.53	77.3%
Purchased Services (-)	\$3,309.00	\$18,336.28	\$73,126.00	\$54,789.72	25.1%
Supplies & Materials (-)	\$0.00	\$618.97	\$1,500.00	\$881.03	41.3%
Other Objects (-)	\$0.00	\$2,538.02	\$1,800.00	(\$738.02)	141.0%
Sub-total : IMPROVEMENT OF INSTRUCTION	(\$46,970.86)	(\$337,286.70)	(\$496,710.00)	(\$159,423.30)	67.9%
EDUCATIONAL MEDIA					
Salaries (-)	\$31,502.55	\$168,013.60	\$273,022.00	\$105,008.40	61.5%
Employee Benefits (-)	\$2,865.40	\$18,483.55	\$31,775.00	\$13,291.45	58.2%
Supplies & Materials (-)	\$3,532.91	\$9,332.01	\$16,000.00	\$6,667.99	58.3%
Sub-total : EDUCATIONAL MEDIA	(\$37,900.86)	(\$195,829.16)	(\$320,797.00)	(\$124,967.84)	61.0%
ADMIN SERVICES - BOARD OF ED					
Employee Benefits (-)	\$0.00	\$62,173.25	\$62,000.00	(\$173.25)	100.3%
Purchased Services (-)	\$11,433.47	\$153,165.83	\$212,700.00	\$59,534.17	72.0%
Supplies & Materials (-)	\$152.40	\$518.28	\$2,500.00	\$1,981.72	20.7%
Capital Expenditures (-)	\$0.00	\$0.00	\$2,000.00	\$2,000.00	0.0%

Operating Statement with Budget

Lincolnwood School District 74

Treasurers Report FUND- All Funds For the Period 03/01/2023 through 03/31/2023

Fiscal Year: 2022-2023

	<u>03/01/2023 - 03/31/2023</u>	<u>Year To Date</u>	<u>Budget</u>	<u>Budget Balance</u>	
Other Objects (-)	\$0.00	\$6,540.00	\$6,540.00	\$0.00	100.0%
Non-Capitalized Equipment (-)	\$0.00	\$0.00	\$1,500.00	\$1,500.00	0.0%
Sub-total : ADMIN SERVICES - BOARD OF ED	(\$11,585.87)	(\$222,397.36)	(\$287,240.00)	(\$64,842.64)	77.4%
SUPERINTENDENT					
Salaries (-)	\$28,529.16	\$229,883.10	\$268,850.00	\$38,966.90	85.5%
Employee Benefits (-)	\$3,868.96	\$43,879.15	\$53,601.00	\$9,721.85	81.9%
Purchased Services (-)	\$345.42	\$8,578.90	\$3,900.00	(\$4,678.90)	220.0%
Supplies & Materials (-)	\$0.00	\$15.23	\$2,000.00	\$1,984.77	0.8%
Capital Expenditures (-)	\$0.00	\$0.00	\$500.00	\$500.00	0.0%
Other Objects (-)	\$0.00	\$1,298.00	\$3,000.00	\$1,702.00	43.3%
Non-Capitalized Equipment (-)	\$0.00	\$0.00	\$500.00	\$500.00	0.0%
Sub-total : SUPERINTENDENT	(\$32,743.54)	(\$283,654.38)	(\$332,351.00)	(\$48,696.62)	85.3%
WORKERS COMPENSATION INSURANCE					
Purchased Services (-)	\$0.00	\$1,103.00	\$69,000.00	\$67,897.00	1.6%
Sub-total : WORKERS COMPENSATION INSURANCE	\$0.00	(\$1,103.00)	(\$69,000.00)	(\$67,897.00)	1.6%
LOSS PREVENTION REDUCTION					
Other Objects (-)	\$0.00	\$0.00	\$5,000.00	\$5,000.00	0.0%
Sub-total : LOSS PREVENTION REDUCTION	\$0.00	\$0.00	(\$5,000.00)	(\$5,000.00)	0.0%
PROPERTY INSURANCE					
Purchased Services (-)	\$0.00	\$23,509.00	\$150,000.00	\$126,491.00	15.7%
Sub-total : PROPERTY INSURANCE	\$0.00	(\$23,509.00)	(\$150,000.00)	(\$126,491.00)	15.7%
PRINCIPAL					
Salaries (-)	\$79,270.75	\$532,721.67	\$688,889.00	\$156,167.33	77.3%
Employee Benefits (-)	\$19,386.47	\$161,623.59	\$215,627.00	\$54,003.41	75.0%
Purchased Services (-)	\$524.95	\$2,888.61	\$5,050.00	\$2,161.39	57.2%
Supplies & Materials (-)	\$31.72	\$948.42	\$4,000.00	\$3,051.58	23.7%
Capital Expenditures (-)	\$0.00	\$0.00	\$1,500.00	\$1,500.00	0.0%
Other Objects (-)	\$0.00	\$1,202.00	\$2,400.00	\$1,198.00	50.1%
Non-Capitalized Equipment (-)	\$0.00	\$3,079.70	\$3,200.00	\$120.30	96.2%
Sub-total : PRINCIPAL	(\$99,213.89)	(\$702,463.99)	(\$920,666.00)	(\$218,202.01)	76.3%
OPERATION OF BUSINESS SERVICES					
Salaries (-)	\$21,935.76	\$146,238.40	\$190,110.00	\$43,871.60	76.9%
Employee Benefits (-)	\$2,894.98	\$24,060.33	\$31,941.00	\$7,880.67	75.3%
Other Objects (-)	\$0.00	\$1,134.00	\$1,400.00	\$266.00	81.0%
Sub-total : OPERATION OF BUSINESS SERVICES	(\$24,830.74)	(\$171,432.73)	(\$223,451.00)	(\$52,018.27)	76.7%
FISCAL SERVICES					
Salaries (-)	\$27,021.39	\$176,517.26	\$231,039.00	\$54,521.74	76.4%
Employee Benefits (-)	\$9,251.43	\$71,539.93	\$93,417.00	\$21,877.07	76.6%
Purchased Services (-)	\$2,698.28	\$4,793.84	\$123,500.00	\$118,706.16	3.9%
Supplies & Materials (-)	\$521.83	\$3,351.34	\$5,500.00	\$2,148.66	60.9%

Operating Statement with Budget

Lincolnwood School District 74

Treasurers Report FUND- All Funds For the Period 03/01/2023 through 03/31/2023

Fiscal Year: 2022-2023

	<u>03/01/2023 - 03/31/2023</u>	<u>Year To Date</u>	<u>Budget</u>	<u>Budget Balance</u>	
Capital Expenditures (-)	\$0.00	\$0.00	\$750.00	\$750.00	0.0%
Other Objects (-)	\$2,362.29	\$18,070.13	\$20,000.00	\$1,929.87	90.4%
Non-Capitalized Equipment (-)	\$0.00	\$548.67	\$1,500.00	\$951.33	36.6%
Sub-total : FISCAL SERVICES	<u>(\$41,855.22)</u>	<u>(\$274,821.17)</u>	<u>(\$475,706.00)</u>	<u>(\$200,884.83)</u>	57.8%
FACILITY ACQUISITION & CONSTRUCTION					
Purchased Services (-)	\$65,096.55	\$602,941.95	\$596,118.00	(\$6,823.95)	101.1%
Capital Expenditures (-)	\$0.00	\$1,191,467.50	\$3,077,144.00	\$1,885,676.50	38.7%
Sub-total : FACILITY ACQUISITION & CONSTRUCTION	<u>(\$65,096.55)</u>	<u>(\$1,794,409.45)</u>	<u>(\$3,673,262.00)</u>	<u>(\$1,878,852.55)</u>	48.9%
OPERATION & MAINTENANCE OF PLANT					
Salaries (-)	\$62,565.85	\$397,743.28	\$526,163.00	\$128,419.72	75.6%
Employee Benefits (-)	\$16,588.99	\$129,832.56	\$171,678.00	\$41,845.44	75.6%
Purchased Services (-)	\$98,760.57	\$715,120.11	\$960,700.00	\$245,579.89	74.4%
Supplies & Materials (-)	\$18,599.70	\$266,278.61	\$453,014.00	\$186,735.39	58.8%
Capital Expenditures (-)	\$0.00	\$81,229.86	\$439,500.00	\$358,270.14	18.5%
Other Objects (-)	\$0.00	\$0.00	\$1,750.00	\$1,750.00	0.0%
Non-Capitalized Equipment (-)	\$0.00	\$1,912.19	\$30,000.00	\$28,087.81	6.4%
Sub-total : OPERATION & MAINTENANCE OF PLANT	<u>(\$196,515.11)</u>	<u>(\$1,592,116.61)</u>	<u>(\$2,582,805.00)</u>	<u>(\$990,688.39)</u>	61.6%
PUPIL TRANSPORTATION					
Purchased Services (-)	\$149,942.41	\$919,073.67	\$1,440,000.00	\$520,926.33	63.8%
Sub-total : PUPIL TRANSPORTATION	<u>(\$149,942.41)</u>	<u>(\$919,073.67)</u>	<u>(\$1,440,000.00)</u>	<u>(\$520,926.33)</u>	63.8%
FOOD SERVICES					
Salaries (-)	\$33,796.78	\$187,963.43	\$250,708.00	\$62,744.57	75.0%
Employee Benefits (-)	\$13,200.24	\$76,242.82	\$103,366.00	\$27,123.18	73.8%
Purchased Services (-)	\$0.00	\$0.00	\$500.00	\$500.00	0.0%
Supplies & Materials (-)	\$29,873.66	\$177,807.11	\$262,000.00	\$84,192.89	67.9%
Capital Expenditures (-)	\$0.00	\$118.28	\$8,000.00	\$7,881.72	1.5%
Other Objects (-)	\$0.00	\$752.50	\$1,000.00	\$247.50	75.3%
Non-Capitalized Equipment (-)	\$0.00	\$0.00	\$4,000.00	\$4,000.00	0.0%
Sub-total : FOOD SERVICES	<u>(\$76,870.68)</u>	<u>(\$442,884.14)</u>	<u>(\$629,574.00)</u>	<u>(\$186,689.86)</u>	70.3%
INTERNAL SERVICES					
Purchased Services (-)	\$1,961.21	\$15,395.74	\$27,100.00	\$11,704.26	56.8%
Supplies & Materials (-)	\$0.00	\$172.00	\$1,500.00	\$1,328.00	11.5%
Sub-total : INTERNAL SERVICES	<u>(\$1,961.21)</u>	<u>(\$15,567.74)</u>	<u>(\$28,600.00)</u>	<u>(\$13,032.26)</u>	54.4%
INFORMATION SERVICES					
Salaries (-)	\$0.00	\$53,312.52	\$78,534.00	\$25,221.48	67.9%
Employee Benefits (-)	\$0.00	\$21,155.46	\$30,706.00	\$9,550.54	68.9%
Purchased Services (-)	\$808.64	\$21,662.31	\$34,250.00	\$12,587.69	63.2%
Supplies & Materials (-)	\$0.00	\$5,463.67	\$6,000.00	\$536.33	91.1%
Other Objects (-)	\$0.00	\$250.00	\$1,000.00	\$750.00	25.0%
Sub-total : INFORMATION SERVICES	<u>(\$808.64)</u>	<u>(\$101,843.96)</u>	<u>(\$150,490.00)</u>	<u>(\$48,646.04)</u>	67.7%

Operating Statement with Budget

Lincolnwood School District 74

Treasurers Report FUND- All Funds For the Period 03/01/2023 through 03/31/2023

Fiscal Year: 2022-2023

	<u>03/01/2023 - 03/31/2023</u>	<u>Year To Date</u>	<u>Budget</u>	<u>Budget Balance</u>	
OTHER SUPPORT SERVICES - ADMIN					
Salaries (-)	\$64,290.31	\$398,257.35	\$534,698.00	\$136,440.65	74.5%
Employee Benefits (-)	\$16,711.07	\$123,060.13	\$183,891.00	\$60,830.87	66.9%
Purchased Services (-)	\$0.00	\$544.62	\$500.00	(\$44.62)	108.9%
Other Objects (-)	\$0.00	\$0.00	\$500.00	\$500.00	0.0%
Sub-total : OTHER SUPPORT SERVICES - ADMIN	(\$81,001.38)	(\$521,862.10)	(\$719,589.00)	(\$197,726.90)	72.5%
COMMUNITY SERVICES					
Purchased Services (-)	\$0.00	\$0.00	\$1,000.00	\$1,000.00	0.0%
Supplies & Materials (-)	\$0.00	\$0.00	\$1,000.00	\$1,000.00	0.0%
Sub-total : COMMUNITY SERVICES	\$0.00	\$0.00	(\$2,000.00)	(\$2,000.00)	0.0%
PAYMENTS TO OTHER LEAs					
Purchased Services (-)	\$0.00	\$63,715.00	\$164,000.00	\$100,285.00	38.9%
Other Objects (-)	\$25,590.97	\$1,349,707.16	\$2,439,019.00	\$1,089,311.84	55.3%
Sub-total : PAYMENTS TO OTHER LEAs	(\$25,590.97)	(\$1,413,422.16)	(\$2,603,019.00)	(\$1,189,596.84)	54.3%
DEBT SERVICE - INTEREST					
Interest on Bonds Outstanding (-)	\$0.00	\$329,725.00	\$640,100.00	\$310,375.00	51.5%
Sub-total : DEBT SERVICE - INTEREST	\$0.00	(\$329,725.00)	(\$640,100.00)	(\$310,375.00)	51.5%
DEBT SERVICE - PRINCIPAL					
Principal Payments on Bonds Outstanding (-)	\$0.00	\$1,165,000.00	\$1,165,000.00	\$0.00	100.0%
Sub-total : DEBT SERVICE - PRINCIPAL	\$0.00	(\$1,165,000.00)	(\$1,165,000.00)	\$0.00	100.0%
DEBT SERVICE - OTHER					
Debt Service Fees (-)	\$0.00	\$0.00	\$2,500.00	\$2,500.00	0.0%
Sub-total : DEBT SERVICE - OTHER	\$0.00	\$0.00	(\$2,500.00)	(\$2,500.00)	0.0%
ADMIN SERVICES - SPECIAL ED					
Salaries (-)	\$17,004.87	\$113,365.80	\$147,376.00	\$34,010.20	76.9%
Employee Benefits (-)	\$3,874.53	\$32,951.99	\$43,347.00	\$10,395.01	76.0%
Other Objects (-)	\$0.00	\$400.00	\$1,000.00	\$600.00	40.0%
Sub-total : ADMIN SERVICES - SPECIAL ED	(\$20,879.40)	(\$146,717.79)	(\$191,723.00)	(\$45,005.21)	76.5%
Total : EXPENDITURES	(\$2,670,216.97)	(\$20,268,830.45)	(\$33,250,483.00)	(\$12,981,652.55)	61.0%
NET INCREASE (DECREASE)	\$3,925,039.18	\$3,184,426.72	(\$1,525,962.00)	(\$4,710,388.72)	208.7%

End of Report

Lincolnwood School District 74

General Ledger - OBJECT REPORT

Fiscal Year: 2022-2023 From Date:3/1/2023 To Date:3/31/2023

Account Mask: ??????????????????

Account Type: EXPENDITURE

Print accounts with zero balance Include Inactive Accounts Include PreEncumbrance

FUND / TYPE / FUNCTION / OBJECT	Preliminary 2023	Range To Date	Year To Date	Encumbrance	Budget Balance
10 - EDUCATIONAL					
0 - EXPENDITURES					
1100 - REGULAR K-12 PROGRAMS					
100 - SALARIES	\$7,735,177.00	\$923,596.23	\$4,801,173.06	\$2,867,448.80	\$66,555.14
200 - EMPLOYEE BENEFITS	\$1,302,684.00	\$97,164.40	\$654,219.81	\$439,639.92	\$208,824.27
300 - PURCHASED SERVICES	\$216,005.00	\$9,028.15	\$129,771.93	\$20,553.00	\$65,680.07
400 - SUPPLIES & MATERIALS	\$549,480.00	\$19,702.48	\$230,586.95	\$77,810.36	\$241,082.69
500 - CAPITAL OUTLAY	\$204,000.00	\$26,416.40	\$109,238.18	\$55,972.89	\$38,788.93
600 - OTHER OBJECTS	\$1,800.00	\$0.00	\$225.00	\$0.00	\$1,575.00
700 - NON-CAPITAL EQUIPMENT	\$117,500.00	\$132.97	\$4,802.05	\$36,150.00	\$76,547.95
800 - TERMINATION/VACATION PAYMENTS	\$397,000.00	\$44,262.41	\$231,013.85	\$27,821.06	\$138,165.09
1125 - PRE-K PROGRAMS					
100 - SALARIES	\$225,356.00	\$27,399.96	\$146,133.12	\$79,021.23	\$201.65
200 - EMPLOYEE BENEFITS	\$58,224.00	\$6,750.82	\$37,602.72	\$14,432.10	\$6,189.18
400 - SUPPLIES & MATERIALS	\$4,300.00	\$284.10	\$1,662.62	\$0.00	\$2,637.38
700 - NON-CAPITAL EQUIPMENT	\$750.00	\$0.00	\$194.02	\$0.00	\$555.98
1200 - SPECIAL ED PROGRAMS K-12					
100 - SALARIES	\$1,198,065.00	\$132,801.04	\$744,505.89	\$397,461.10	\$56,098.01
200 - EMPLOYEE BENEFITS	\$286,424.00	\$21,555.21	\$135,550.18	\$78,624.03	\$72,249.79
300 - PURCHASED SERVICES	\$600.00	\$380.00	\$535.75	\$0.00	\$64.25
400 - SUPPLIES & MATERIALS	\$5,500.00	\$136.07	\$1,005.66	\$0.00	\$4,494.34
500 - CAPITAL OUTLAY	\$6,000.00	\$0.00	\$2,338.09	\$0.00	\$3,661.91
600 - OTHER OBJECTS	\$200.00	\$0.00	\$180.00	\$0.00	\$20.00
700 - NON-CAPITAL EQUIPMENT	\$5,000.00	\$0.00	\$1,742.40	\$0.00	\$3,257.60
1250 - REMEDIAL & SUPPLEMENTAL K-12					
100 - SALARIES	\$585,251.00	\$67,528.44	\$360,151.68	\$225,095.32	\$4.00
200 - EMPLOYEE BENEFITS	\$102,383.00	\$8,824.27	\$57,020.64	\$39,372.13	\$5,990.23
300 - PURCHASED SERVICES	\$56,795.00	\$0.00	\$41,999.55	\$0.00	\$14,795.45
400 - SUPPLIES & MATERIALS	\$12,250.00	\$171.18	\$5,636.36	\$0.00	\$6,613.64
1500 - INTERSCHOLASTIC PROGRAMS					
100 - SALARIES	\$90,000.00	\$35,410.96	\$72,283.20	\$3,655.49	\$14,061.31
200 - EMPLOYEE BENEFITS	\$1,200.00	\$399.47	\$761.90	\$37.45	\$400.65
400 - SUPPLIES & MATERIALS	\$5,500.00	\$157.96	\$6,886.70	\$0.00	(\$1,386.70)
500 - CAPITAL OUTLAY	\$1,500.00	\$0.00	\$0.00	\$0.00	\$1,500.00

Lincolnwood School District 74

General Ledger - OBJECT REPORT

Fiscal Year: 2022-2023 From Date:3/1/2023 To Date:3/31/2023

Account Mask: ????????????????????

Account Type: EXPENDITURE

Print accounts with zero balance
 Include Inactive Accounts
 Include PreEncumbrance

FUND / TYPE / FUNCTION / OBJECT	Preliminary 2023	Range To Date	Year To Date	Encumbrance	Budget Balance
600 - OTHER OBJECTS	\$3,600.00	\$0.00	\$3,500.00	\$0.00	\$100.00
1600 - SUMMER SCHOOL PROGRAMS					
100 - SALARIES	\$42,491.00	\$513.00	\$31,339.54	\$461.70	\$10,689.76
200 - EMPLOYEE BENEFITS	\$4,315.00	\$60.27	\$3,048.11	\$54.22	\$1,212.67
400 - SUPPLIES & MATERIALS	\$3,117.00	\$148.98	\$1,709.61	\$0.00	\$1,407.39
1650 - GIFTED PROGRAMS					
100 - SALARIES	\$450,386.00	\$51,967.59	\$277,160.48	\$173,225.52	\$0.00
200 - EMPLOYEE BENEFITS	\$64,287.00	\$5,523.88	\$37,326.76	\$26,279.01	\$681.23
400 - SUPPLIES & MATERIALS	\$4,250.00	\$50.00	\$3,070.22	\$115.00	\$1,064.78
1800 - BILINGUAL PROGRAMS					
100 - SALARIES	\$693,562.00	\$80,484.63	\$415,440.88	\$259,299.54	\$18,821.58
200 - EMPLOYEE BENEFITS	\$91,365.00	\$7,978.55	\$52,037.63	\$36,552.14	\$2,775.23
300 - PURCHASED SERVICES	\$1,800.00	\$0.00	\$0.00	\$0.00	\$1,800.00
400 - SUPPLIES & MATERIALS	\$1,750.00	\$1,126.59	\$5,684.53	\$57.86	(\$3,992.39)
2110 - ATTENDANCE & SOCIAL WORK					
100 - SALARIES	\$404,123.00	\$46,629.57	\$248,691.04	\$155,431.96	\$0.00
200 - EMPLOYEE BENEFITS	\$35,333.00	\$3,488.60	\$23,216.65	\$16,240.45	(\$4,124.10)
400 - SUPPLIES & MATERIALS	\$1,000.00	\$57.59	\$626.53	\$0.00	\$373.47
2120 - GUIDANCE SERVICES					
300 - PURCHASED SERVICES	\$5,000.00	\$0.00	\$0.00	\$0.00	\$5,000.00
2130 - HEALTH SERVICES					
100 - SALARIES	\$159,352.00	\$22,295.27	\$123,685.26	\$36,208.48	(\$541.74)
200 - EMPLOYEE BENEFITS	\$36,803.00	\$5,196.21	\$27,701.22	\$8,668.35	\$433.43
300 - PURCHASED SERVICES	\$31,000.00	\$5,475.00	\$34,959.09	\$0.00	(\$3,959.09)
400 - SUPPLIES & MATERIALS	\$5,300.00	\$300.43	\$4,404.75	\$160.60	\$734.65
500 - CAPITAL OUTLAY	\$2,250.00	\$0.00	\$223.28	\$0.00	\$2,026.72
600 - OTHER OBJECTS	\$750.00	\$0.00	\$0.00	\$0.00	\$750.00
700 - NON-CAPITAL EQUIPMENT	\$1,600.00	\$0.00	\$0.00	\$0.00	\$1,600.00
2140 - PSYCHOLOGICAL SERVICES					
100 - SALARIES	\$179,584.00	\$20,721.24	\$110,513.28	\$69,070.72	\$0.00
200 - EMPLOYEE BENEFITS	\$35,198.00	\$2,985.46	\$20,365.62	\$14,394.70	\$437.68
300 - PURCHASED SERVICES	\$1,100.00	\$0.00	\$0.00	\$0.00	\$1,100.00
400 - SUPPLIES & MATERIALS	\$1,850.00	\$0.00	\$1,272.59	\$63.58	\$513.83
2150 - SPEECH PATHOLOGY & AUDIOLOGY					
100 - SALARIES	\$274,591.00 ³⁵⁶	\$31,666.47	\$168,979.04	\$105,611.96	\$0.00

Lincolnwood School District 74

General Ledger - OBJECT REPORT

Fiscal Year: 2022-2023 From Date:3/1/2023 To Date:3/31/2023

Account Mask: ??????????????????

Account Type: EXPENDITURE

Print accounts with zero balance
 Include Inactive Accounts
 Include PreEncumbrance

FUND / TYPE / FUNCTION / OBJECT	Preliminary 2023	Range To Date	Year To Date	Encumbrance	Budget Balance
200 - EMPLOYEE BENEFITS	\$37,095.00	\$3,188.05	\$21,517.84	\$15,143.30	\$433.86
300 - PURCHASED SERVICES	\$360.00	\$0.00	\$443.16	\$0.00	(\$83.16)
400 - SUPPLIES & MATERIALS	\$1,800.00	\$112.78	\$406.32	\$530.20	\$863.48
2190 - OTHER SUPPORT SERVICES - PUPILS					
100 - SALARIES	\$101,000.00	\$12,041.95	\$47,101.39	\$11,736.00	\$42,162.61
200 - EMPLOYEE BENEFITS	\$900.00	\$44.23	\$157.75	\$53.60	\$688.65
2210 - IMPROVEMENT OF INSTRUCTION					
100 - SALARIES	\$364,189.00	\$38,547.09	\$272,451.96	\$74,324.62	\$17,412.42
200 - EMPLOYEE BENEFITS	\$41,959.00	\$3,582.73	\$32,179.71	\$8,210.67	\$1,568.62
300 - PURCHASED SERVICES	\$73,126.00	\$3,309.00	\$18,336.28	\$0.00	\$54,789.72
400 - SUPPLIES & MATERIALS	\$1,500.00	\$0.00	\$618.97	\$0.00	\$881.03
600 - OTHER OBJECTS	\$1,800.00	\$0.00	\$2,538.02	\$0.00	(\$738.02)
2220 - EDUCATIONAL MEDIA					
100 - SALARIES	\$273,022.00	\$31,502.55	\$168,013.60	\$105,008.40	\$0.00
200 - EMPLOYEE BENEFITS	\$27,814.00	\$2,419.60	\$16,123.40	\$11,284.20	\$406.40
400 - SUPPLIES & MATERIALS	\$16,000.00	\$3,532.91	\$9,332.01	\$889.93	\$5,778.06
2310 - BOARD OF EDUCATION					
200 - EMPLOYEE BENEFITS	\$62,000.00	\$0.00	\$62,173.25	\$0.00	(\$173.25)
300 - PURCHASED SERVICES	\$212,700.00	\$11,433.47	\$153,165.83	\$0.00	\$59,534.17
400 - SUPPLIES & MATERIALS	\$2,500.00	\$152.40	\$518.28	\$0.00	\$1,981.72
500 - CAPITAL OUTLAY	\$2,000.00	\$0.00	\$0.00	\$0.00	\$2,000.00
600 - OTHER OBJECTS	\$6,540.00	\$0.00	\$6,540.00	\$0.00	\$0.00
700 - NON-CAPITAL EQUIPMENT	\$1,500.00	\$0.00	\$0.00	\$0.00	\$1,500.00
2320 - SUPERINTENDENT					
100 - SALARIES	\$268,850.00	\$28,529.16	\$229,883.10	\$57,058.33	(\$18,091.43)
200 - EMPLOYEE BENEFITS	\$49,650.00	\$3,456.37	\$40,559.19	\$8,047.82	\$1,042.99
300 - PURCHASED SERVICES	\$3,900.00	\$345.42	\$8,578.90	\$0.00	(\$4,678.90)
400 - SUPPLIES & MATERIALS	\$2,000.00	\$0.00	\$15.23	\$0.00	\$1,984.77
500 - CAPITAL OUTLAY	\$500.00	\$0.00	\$0.00	\$0.00	\$500.00
600 - OTHER OBJECTS	\$3,000.00	\$0.00	\$1,298.00	\$0.00	\$1,702.00
700 - NON-CAPITAL EQUIPMENT	\$500.00	\$0.00	\$0.00	\$0.00	\$500.00
2330 - ADMINISTRATIVE SERVICES SPECIAL ED					
100 - SALARIES	\$147,376.00	\$17,004.87	\$113,365.80	\$33,898.13	\$112.07
200 - EMPLOYEE BENEFITS	\$38,258.00	\$3,331.88	\$29,132.62	\$8,040.27	\$1,085.11
600 - OTHER OBJECTS	\$1,000.00	\$0.00	\$400.00	\$0.00	\$600.00

Lincolnwood School District 74

General Ledger - OBJECT REPORT

Fiscal Year: 2022-2023 From Date:3/1/2023 To Date:3/31/2023

Account Mask: ????????????????????

Account Type: EXPENDITURE

Print accounts with zero balance
 Include Inactive Accounts
 Include PreEncumbrance

FUND / TYPE / FUNCTION / OBJECT	Preliminary 2023	Range To Date	Year To Date	Encumbrance	Budget Balance
2410 - PRINCIPAL					
100 - SALARIES	\$688,889.00	\$79,270.75	\$532,721.67	\$158,522.19	(\$2,354.86)
200 - EMPLOYEE BENEFITS	\$179,022.00	\$15,662.58	\$134,982.88	\$43,812.59	\$226.53
300 - PURCHASED SERVICES	\$5,050.00	\$524.95	\$2,888.61	\$0.00	\$2,161.39
400 - SUPPLIES & MATERIALS	\$4,000.00	\$31.72	\$948.42	\$0.00	\$3,051.58
500 - CAPITAL OUTLAY	\$1,500.00	\$0.00	\$0.00	\$0.00	\$1,500.00
600 - OTHER OBJECTS	\$2,400.00	\$0.00	\$1,202.00	\$0.00	\$1,198.00
700 - NON-CAPITAL EQUIPMENT	\$3,200.00	\$0.00	\$3,079.70	\$0.00	\$120.30
2510 - DIRECTION OF BUSINESS SUPPORT SERVICES					
100 - SALARIES	\$190,110.00	\$21,935.76	\$146,238.40	\$43,871.47	\$0.13
200 - EMPLOYEE BENEFITS	\$29,183.00	\$2,578.54	\$21,963.15	\$7,205.10	\$14.75
600 - OTHER OBJECTS	\$1,400.00	\$0.00	\$1,134.00	\$0.00	\$266.00
2520 - FISCAL SERVICES					
100 - SALARIES	\$231,039.00	\$27,021.39	\$176,517.26	\$54,042.60	\$479.14
200 - EMPLOYEE BENEFITS	\$54,870.00	\$5,336.50	\$43,608.12	\$15,931.47	(\$4,669.59)
300 - PURCHASED SERVICES	\$123,500.00	\$2,698.28	\$4,793.84	\$0.00	\$118,706.16
400 - SUPPLIES & MATERIALS	\$5,500.00	\$521.83	\$3,351.34	\$0.00	\$2,148.66
500 - CAPITAL OUTLAY	\$750.00	\$0.00	\$0.00	\$0.00	\$750.00
600 - OTHER OBJECTS	\$20,000.00	\$2,362.29	\$18,070.13	\$0.00	\$1,929.87
700 - NON-CAPITAL EQUIPMENT	\$1,500.00	\$0.00	\$548.67	\$0.00	\$951.33
2560 - FOOD SERVICES					
100 - SALARIES	\$250,708.00	\$33,796.78	\$187,963.43	\$52,531.17	\$10,213.40
200 - EMPLOYEE BENEFITS	\$61,893.00	\$8,347.30	\$46,446.16	\$14,603.01	\$843.83
300 - PURCHASED SERVICES	\$500.00	\$0.00	\$0.00	\$0.00	\$500.00
400 - SUPPLIES & MATERIALS	\$262,000.00	\$29,873.66	\$177,807.11	\$0.00	\$84,192.89
500 - CAPITAL OUTLAY	\$8,000.00	\$0.00	\$118.28	\$0.00	\$7,881.72
600 - OTHER OBJECTS	\$1,000.00	\$0.00	\$752.50	\$0.00	\$247.50
700 - NON-CAPITAL EQUIPMENT	\$4,000.00	\$0.00	\$0.00	\$0.00	\$4,000.00
2570 - INTERNAL SERVICES					
300 - PURCHASED SERVICES	\$27,100.00	\$1,961.21	\$15,395.74	\$600.00	\$11,104.26
400 - SUPPLIES & MATERIALS	\$1,500.00	\$0.00	\$172.00	\$0.00	\$1,328.00
2630 - INFORMATION SERVICES					
100 - SALARIES	\$78,534.00	\$0.00	\$53,312.52	\$0.00	\$25,221.48
200 - EMPLOYEE BENEFITS	\$17,646.00	\$0.00	\$12,106.25	\$0.00	\$5,539.75
300 - PURCHASED SERVICES	\$34,250.00	\$808.64	\$21,662.31	\$0.00	\$12,587.69

Lincolnwood School District 74

General Ledger - OBJECT REPORT

Fiscal Year: 2022-2023 From Date:3/1/2023 To Date:3/31/2023

Account Mask: ??????????????????

Account Type: EXPENDITURE

Print accounts with zero balance
 Include Inactive Accounts
 Include PreEncumbrance

FUND / TYPE / FUNCTION / OBJECT	Preliminary 2023	Range To Date	Year To Date	Encumbrance	Budget Balance
400 - SUPPLIES & MATERIALS	\$6,000.00	\$0.00	\$5,463.67	\$0.00	\$536.33
600 - OTHER OBJECTS	\$1,000.00	\$0.00	\$250.00	\$0.00	\$750.00
2660 - OTHER SUPPORT SERVICES - PUPILS					
100 - SALARIES	\$534,698.00	\$64,290.31	\$398,257.35	\$125,226.61	\$11,214.04
200 - EMPLOYEE BENEFITS	\$119,278.00	\$9,784.99	\$77,746.26	\$23,947.82	\$17,583.92
300 - PURCHASED SERVICES	\$500.00	\$0.00	\$544.62	\$0.00	(\$44.62)
600 - OTHER OBJECTS	\$500.00	\$0.00	\$0.00	\$0.00	\$500.00
3000 - COMMUNITY SERVICES					
300 - PURCHASED SERVICES	\$1,000.00	\$0.00	\$0.00	\$0.00	\$1,000.00
400 - SUPPLIES & MATERIALS	\$1,000.00	\$0.00	\$0.00	\$0.00	\$1,000.00
4120 - PAYMENTS FOR SPECIAL ED PROGRAMS					
300 - PURCHASED SERVICES	\$164,000.00	\$0.00	\$63,715.00	\$0.00	\$100,285.00
600 - OTHER OBJECTS	\$2,439,019.00	\$25,590.97	\$1,349,707.16	\$0.00	\$1,089,311.84
10 - EDUCATIONAL Total:	\$23,003,579.00	\$2,203,704.76	\$14,110,496.58	\$6,139,510.17	\$2,753,572.25

Lincolnwood School District 74

General Ledger - OBJECT REPORT

Fiscal Year: 2022-2023 From Date:3/1/2023 To Date:3/31/2023

Account Mask: ????????????????????

Account Type: EXPENDITURE

Print accounts with zero balance
 Include Inactive Accounts
 Include PreEncumbrance

FUND / TYPE / FUNCTION / OBJECT	Preliminary 2023	Range To Date	Year To Date	Encumbrance	Budget Balance
20 - OPERATIONS & MAINTENANCE					
0 - EXPENDITURES					
2540 - OPERATIONS & MAINTENANCE OF PLANTS					
100 - SALARIES	\$526,163.00	\$62,565.85	\$397,743.28	\$113,049.99	\$15,369.73
200 - EMPLOYEE BENEFITS	\$83,217.00	\$7,237.92	\$64,731.39	\$21,555.85	(\$3,070.24)
300 - PURCHASED SERVICES	\$960,700.00	\$98,760.57	\$715,120.11	\$15,105.84	\$230,474.05
400 - SUPPLIES & MATERIALS	\$453,014.00	\$18,599.70	\$266,278.61	\$14,294.87	\$172,440.52
500 - CAPITAL OUTLAY	\$186,500.00	\$0.00	\$31,229.86	\$15,150.42	\$140,119.72
600 - OTHER OBJECTS	\$1,750.00	\$0.00	\$0.00	\$0.00	\$1,750.00
700 - NON-CAPITAL EQUIPMENT	\$30,000.00	\$0.00	\$1,912.19	\$0.00	\$28,087.81
20 - OPERATIONS & MAINTENANCE Total:	\$2,241,344.00	\$187,164.04	\$1,477,015.44	\$179,156.97	\$585,171.59

Lincolnwood School District 74

General Ledger - OBJECT REPORT

Fiscal Year: 2022-2023 From Date:3/1/2023 To Date:3/31/2023

Account Mask: ????????????????????

Account Type: EXPENDITURE

Print accounts with zero balance
 Include Inactive Accounts
 Include PreEncumbrance

FUND / TYPE / FUNCTION / OBJECT	Preliminary 2023	Range To Date	Year To Date	Encumbrance	Budget Balance
30 - DEBT SERVICE					
0 - EXPENDITURES					
5140 - DEBT SERVICE - INTEREST PAYMENTS					
600 - OTHER OBJECTS	\$640,100.00	\$0.00	\$329,725.00	\$0.00	\$310,375.00
5200 - INTEREST ON BONDS OUTSTANDING					
600 - OTHER OBJECTS	\$1,165,000.00	\$0.00	\$1,165,000.00	\$0.00	\$0.00
5400 - DEBT SERVICE LEASES					
600 - OTHER OBJECTS	\$2,500.00	\$0.00	\$0.00	\$0.00	\$2,500.00
30 - DEBT SERVICE Total:	\$1,807,600.00	\$0.00	\$1,494,725.00	\$0.00	\$312,875.00

Lincolnwood School District 74

General Ledger - OBJECT REPORT

Fiscal Year: 2022-2023 From Date:3/1/2023 To Date:3/31/2023

Account Mask: ??????????????????

Account Type: EXPENDITURE

Print accounts with zero balance Include Inactive Accounts Include PreEncumbrance

FUND / TYPE / FUNCTION / OBJECT

Preliminary 2023 Range To Date Year To Date Encumbrance Budget Balance

40 - TRANSPORTATION

0 - EXPENDITURES

2550 - PUPIL TRANSPORTATION

300 - PURCHASED SERVICES

\$1,440,000.00	\$149,942.41	\$919,073.67	\$0.00	\$520,926.33
----------------	--------------	--------------	--------	--------------

40 - TRANSPORTATION Total:	\$1,440,000.00	\$149,942.41	\$919,073.67	\$0.00	\$520,926.33
----------------------------	----------------	--------------	--------------	--------	--------------

Lincolnwood School District 74

General Ledger - OBJECT REPORT

Fiscal Year: 2022-2023 From Date:3/1/2023 To Date:3/31/2023

Account Mask: ??????????????????

Account Type: EXPENDITURE

Print accounts with zero balance
 Include Inactive Accounts
 Include PreEncumbrance

FUND / TYPE / FUNCTION / OBJECT	Preliminary 2023	Range To Date	Year To Date	Encumbrance	Budget Balance
51 - IMRF					
0 - EXPENDITURES					
1100 - REGULAR K-12 PROGRAMS					
200 - EMPLOYEE BENEFITS	\$3,875.00	\$291.83	\$1,790.90	\$366.29	\$1,717.81
1125 - PRE-K PROGRAMS					
200 - EMPLOYEE BENEFITS	\$4,700.00	\$559.20	\$3,514.30	\$932.00	\$253.70
1200 - SPECIAL ED PROGRAMS K-12					
200 - EMPLOYEE BENEFITS	\$30,100.00	\$2,852.85	\$19,438.29	\$5,111.64	\$5,550.07
1500 - INTERSCHOLASTIC PROGRAMS					
200 - EMPLOYEE BENEFITS	\$2,400.00	\$261.86	\$494.38	\$50.48	\$1,855.14
1600 - SUMMER SCHOOL PROGRAMS					
200 - EMPLOYEE BENEFITS	\$1,000.00	\$0.00	\$199.04	\$0.00	\$800.96
1800 - BILINGUAL PROGRAMS					
200 - EMPLOYEE BENEFITS	\$300.00	\$56.97	\$85.46	\$36.25	\$178.29
2130 - HEALTH SERVICES					
200 - EMPLOYEE BENEFITS	\$16,800.00	\$1,687.75	\$11,062.44	\$2,740.99	\$2,996.57
2190 - OTHER SUPPORT SERVICES - PUPILS					
200 - EMPLOYEE BENEFITS	\$1,100.00	\$0.00	\$0.00	\$6.26	\$1,093.74
2210 - IMPROVEMENT OF INSTRUCTION					
200 - EMPLOYEE BENEFITS	\$5,600.00	\$538.92	\$4,340.10	\$1,077.84	\$182.06
2330 - ADMINISTRATIVE SERVICES SPECIAL ED					
200 - EMPLOYEE BENEFITS	\$1,750.00	\$169.05	\$1,359.18	\$329.64	\$61.18
2410 - PRINCIPAL					
200 - EMPLOYEE BENEFITS	\$15,720.00	\$1,517.35	\$12,273.13	\$3,033.21	\$413.66
2520 - FISCAL SERVICES					
200 - EMPLOYEE BENEFITS	\$21,000.00	\$2,045.52	\$16,085.63	\$4,091.03	\$823.34
2540 - OPERATIONS & MAINTENANCE OF PLANTS					
200 - EMPLOYEE BENEFITS	\$48,200.00	\$4,731.89	\$36,167.57	\$8,549.14	\$3,483.29
2560 - FOOD SERVICES					
200 - EMPLOYEE BENEFITS	\$22,300.00	\$2,523.82	\$16,844.84	\$3,884.37	\$1,570.79
2630 - INFORMATION SERVICES					
200 - EMPLOYEE BENEFITS	\$7,050.00	\$0.00	\$4,978.18	\$0.00	\$2,071.82
2660 - OTHER SUPPORT SERVICES - PUPILS					
200 - EMPLOYEE BENEFITS	\$34,000.00	\$3,426.99	\$24,599.30	\$6,600.10	\$2,800.60
51 - IMRF Total:	\$215,895.00	\$20,664.00	\$153,232.74	\$36,809.24	\$25,853.02

Lincolnwood School District 74

General Ledger - OBJECT REPORT

Fiscal Year: 2022-2023 From Date:3/1/2023 To Date:3/31/2023

Account Mask: ????????????????????

Account Type: EXPENDITURE

Print accounts with zero balance
 Include Inactive Accounts
 Include PreEncumbrance

FUND / TYPE / FUNCTION / OBJECT	Preliminary 2023	Range To Date	Year To Date	Encumbrance	Budget Balance
52 - SOCIAL SECURITY AND MEDICARE					
0 - EXPENDITURES					
1100 - REGULAR K-12 PROGRAMS					
200 - EMPLOYEE BENEFITS	\$124,215.00	\$14,910.87	\$74,501.77	\$40,735.86	\$8,977.37
1125 - PRE-K PROGRAMS					
200 - EMPLOYEE BENEFITS	\$6,489.00	\$626.46	\$3,333.55	\$1,511.91	\$1,643.54
1200 - SPECIAL ED PROGRAMS K-12					
200 - EMPLOYEE BENEFITS	\$38,433.00	\$3,861.99	\$21,734.75	\$8,752.42	\$7,945.83
1250 - REMEDIAL & SUPPLEMENTAL K-12					
200 - EMPLOYEE BENEFITS	\$8,492.00	\$943.76	\$4,973.96	\$3,083.65	\$434.39
1500 - INTERSCHOLASTIC PROGRAMS					
200 - EMPLOYEE BENEFITS	\$3,805.00	\$720.15	\$1,715.43	\$85.18	\$2,004.39
1600 - SUMMER SCHOOL PROGRAMS					
200 - EMPLOYEE BENEFITS	\$4,785.00	\$7.22	\$853.50	\$6.43	\$3,925.07
1650 - GIFTED PROGRAMS					
200 - EMPLOYEE BENEFITS	\$6,534.00	\$724.75	\$3,817.59	\$2,367.20	\$349.21
1800 - BILINGUAL PROGRAMS					
200 - EMPLOYEE BENEFITS	\$9,639.00	\$1,162.19	\$5,776.52	\$3,560.65	\$301.83
2110 - ATTENDANCE & SOCIAL WORK					
200 - EMPLOYEE BENEFITS	\$5,863.00	\$658.61	\$3,483.20	\$2,166.19	\$213.61
2130 - HEALTH SERVICES					
200 - EMPLOYEE BENEFITS	\$12,192.00	\$1,528.21	\$8,517.21	\$2,474.33	\$1,200.46
2140 - PSYCHOLOGICAL SERVICES					
200 - EMPLOYEE BENEFITS	\$2,606.00	\$284.82	\$1,494.17	\$922.23	\$189.60
2150 - SPEECH PATHOLOGY & AUDIOLOGY					
200 - EMPLOYEE BENEFITS	\$3,984.00	\$436.43	\$2,292.78	\$1,417.70	\$273.52
2190 - OTHER SUPPORT SERVICES - PUPILS					
200 - EMPLOYEE BENEFITS	\$7,732.00	\$714.86	\$2,827.22	\$629.24	\$4,275.54
2210 - IMPROVEMENT OF INSTRUCTION					
200 - EMPLOYEE BENEFITS	\$8,536.00	\$993.12	\$6,821.66	\$1,941.19	(\$226.85)
2220 - EDUCATIONAL MEDIA					
200 - EMPLOYEE BENEFITS	\$3,961.00	\$445.80	\$2,360.15	\$1,466.73	\$134.12
2320 - SUPERINTENDENT					
200 - EMPLOYEE BENEFITS	\$3,951.00	\$412.59	\$3,319.96	\$824.10	(\$193.06)
2330 - ADMINISTRATIVE SERVICES SPECIAL ED		364			

Lincolnwood School District 74

General Ledger - OBJECT REPORT

Fiscal Year: 2022-2023 From Date:3/1/2023 To Date:3/31/2023

Account Mask: ????????????????????

Account Type: EXPENDITURE

Print accounts with zero balance
 Include Inactive Accounts
 Include PreEncumbrance

FUND / TYPE / FUNCTION / OBJECT	Preliminary 2023	Range To Date	Year To Date	Encumbrance	Budget Balance
200 - EMPLOYEE BENEFITS	\$3,339.00	\$373.60	\$2,460.19	\$727.24	\$151.57
2410 - PRINCIPAL					
200 - EMPLOYEE BENEFITS	\$20,885.00	\$2,206.54	\$14,367.58	\$4,211.28	\$2,306.14
2510 - DIRECTION OF BUSINESS SUPPORT SERVICES					
200 - EMPLOYEE BENEFITS	\$2,758.00	\$316.44	\$2,097.18	\$631.26	\$29.56
2520 - FISCAL SERVICES					
200 - EMPLOYEE BENEFITS	\$17,547.00	\$1,869.41	\$11,846.18	\$3,538.30	\$2,162.52
2540 - OPERATIONS & MAINTENANCE OF PLANTS					
200 - EMPLOYEE BENEFITS	\$40,261.00	\$4,619.18	\$28,933.60	\$8,151.32	\$3,176.08
2560 - FOOD SERVICES					
200 - EMPLOYEE BENEFITS	\$19,173.00	\$2,329.12	\$12,951.82	\$3,569.49	\$2,651.69
2630 - INFORMATION SERVICES					
200 - EMPLOYEE BENEFITS	\$6,010.00	\$0.00	\$4,071.03	\$0.00	\$1,938.97
2660 - OTHER SUPPORT SERVICES - PUPILS					
200 - EMPLOYEE BENEFITS	\$30,613.00	\$3,499.09	\$20,714.57	\$6,598.35	\$3,300.08
52 - SOCIAL SECURITY AND MEDICARE Total:	\$391,803.00	\$43,645.21	\$245,265.57	\$99,372.25	\$47,165.18

Lincolnwood School District 74

General Ledger - OBJECT REPORT

Fiscal Year: 2022-2023 From Date:3/1/2023 To Date:3/31/2023

Account Mask: ????????????????????

Account Type: EXPENDITURE

Print accounts with zero balance Include Inactive Accounts Include PreEncumbrance

FUND / TYPE / FUNCTION / OBJECT

Preliminary 2023 Range To Date Year To Date Encumbrance Budget Balance

60 - CAPITAL PROJECTS

0 - EXPENDITURES

2530 - FACILITY ACQUISITION & CONSTRUCTION

FUND / TYPE / FUNCTION / OBJECT	Preliminary 2023	Range To Date	Year To Date	Encumbrance	Budget Balance
300 - PURCHASED SERVICES	\$571,118.00	\$64,116.95	\$554,429.95	\$0.00	\$16,688.05
500 - CAPITAL OUTLAY	\$3,077,144.00	\$0.00	\$1,191,467.50	\$304,450.00	\$1,581,226.50
60 - CAPITAL PROJECTS Total:	\$3,648,262.00	\$64,116.95	\$1,745,897.45	\$304,450.00	\$1,597,914.55

Lincolnwood School District 74

General Ledger - OBJECT REPORT

Fiscal Year: 2022-2023 From Date:3/1/2023 To Date:3/31/2023

Account Mask: ??????????????????

Account Type: EXPENDITURE

Print accounts with zero balance
 Include Inactive Accounts
 Include PreEncumbrance

FUND / TYPE / FUNCTION / OBJECT	Preliminary 2023	Range To Date	Year To Date	Encumbrance	Budget Balance
80 - TORT IMMUNITY					
0 - EXPENDITURES					
2362 - WORKERS COMPENSATION INSURANCE					
300 - PURCHASED SERVICES	\$69,000.00	\$0.00	\$1,103.00	\$0.00	\$67,897.00
2366 - JUDGMENTS/SETTLEMENTS					
600 - OTHER OBJECTS	\$5,000.00	\$0.00	\$0.00	\$0.00	\$5,000.00
2371 - PROPERTY INSURANCE					
300 - PURCHASED SERVICES	\$150,000.00	\$0.00	\$23,509.00	\$0.00	\$126,491.00
80 - TORT IMMUNITY Total:	\$224,000.00	\$0.00	\$24,612.00	\$0.00	\$199,388.00

Lincolnwood School District 74

General Ledger - OBJECT REPORT

Fiscal Year: 2022-2023 From Date:3/1/2023 To Date:3/31/2023

Account Mask: ??????????????????

Account Type: EXPENDITURE

Print accounts with zero balance Include Inactive Accounts Include PreEncumbrance

FUND / TYPE / FUNCTION / OBJECT

Preliminary 2023 Range To Date Year To Date Encumbrance Budget Balance

90 - FIRE PREVENTION & SAFETY					
0 - EXPENDITURES					
2530 - FACILITY ACQUISITION & CONSTRUCTION					
300 - PURCHASED SERVICES	\$25,000.00	\$979.60	\$48,512.00	\$0.00	(\$23,512.00)
2540 - OPERATIONS & MAINTENANCE OF PLANTS					
500 - CAPITAL OUTLAY	\$253,000.00	\$0.00	\$50,000.00	\$0.00	\$203,000.00
90 - FIRE PREVENTION & SAFETY Total:	\$278,000.00	\$979.60	\$98,512.00	\$0.00	\$179,488.00

Lincolnwood School District 74

General Ledger - OBJECT REPORT

Fiscal Year: 2022-2023 From Date:3/1/2023 To Date:3/31/2023

Account Mask: ??????????????????

Account Type: EXPENDITURE

- Print accounts with zero balance
 Include Inactive Accounts
 Include PreEncumbrance

FUND / TYPE / FUNCTION / OBJECT	Preliminary 2023	Range To Date	Year To Date	Encumbrance	Budget Balance
Grand Total:	\$33,250,483.00	\$2,670,216.97	\$20,268,830.45	\$6,759,298.63	\$6,222,353.92

End of Report

**LINCOLNWOOD SCHOOL DISTRICT 74
BILLS PAYABLE**

Education Fund	805,872.30
Building Fund	124,445.13
Debt Service	-
Transportation Fund	154,743.44
I.M.R.F./Soc. Sec.	-
Capital Projects	65,571.45
Tort Fund	-
Life Safety Fund	-
	<hr/>
Grand Total	1,150,632.32

The undersigned hereby certify that the foregoing is a true and correct list of bills payable, approved and ordered paid by the Board of Education, School District #74, Cook County, at a meeting duly called and held on June 1, 2023, in the amount of **1,150,632.32**

President, Kevin Daly

Secretary, John P. Vranas

Members:

Maxie Boynton

Myra A Foutris

Rupal Shah Mandal

Jay Oleniczak

Peter D. Theodore

Lincolnwood School District 74

Disbursement Detail Listing

Bank Name: COLE TAYLOR BANK - ACCOUNTS PAYABLE Date Range: 05/01/2023 - 05/31/2023 Sort By: Vendor
 Fiscal Year: 2022-2023 Voucher Range: - Dollar Limit: \$0.00

Print Employee Vendor Names
 Exclude Voided Checks
 Exclude Manual Checks
 Include Non Check Batches

Check Number	Date	Voucher	Payee	Account	Description	Amount
Bank Name: COLE TAYLOR BANK - ACCOUNTS PAYABLE						
NCB	05/10/2023	1282	4 IMPRINT	10.0.2310.340.00.0000.00	BUDGET-BEATER GOLF UMBRELLA	\$328.73
						Check Total: \$328.73
7400027642	05/04/2023	1273	ACCESS MASTER	20.0.2540.302.00.0000.00	ACCESS CONTROL	\$1,638.00
7400027642	05/04/2023	1273	ACCESS MASTER	20.0.2540.302.00.0000.00	SURVEILLANCE SYSTEM MONITORING	\$900.90
7400027642	05/04/2023	1273	ACCESS MASTER	20.0.2540.302.00.0000.00	CAMERA SYSTEM	\$2,178.95
						Check Total: \$4,717.85
7400027704	05/18/2023	1297	ACCESS MASTER	20.0.2540.302.00.0000.00	ACCESS CONTROL	\$3,135.00
7400027704	05/18/2023	1297	ACCESS MASTER	20.0.2540.302.00.0000.00	RUTLEDGE CAMERA ADDITIONS-MAY 23, 2016	\$392.00
7400027704	05/18/2023	1297	ACCESS MASTER	20.0.2540.302.00.0000.00	CAMERA SYSTEM	\$2,178.95
						Check Total: \$5,705.95
7400027705	05/18/2023	1297	ACCO BRANDS USA LLC	10.0.2570.414.00.0000.03	CONTROL PANEL	\$477.87
						Check Total: \$477.87
NCB	05/10/2023	1282	ADLER PLANETARIUM	10.0.1100.314.04.0000.02	IL SCHOOL GROUP STUDENT SHOW	\$1,120.00
NCB	05/10/2023	1282	ADOBE SYSTEMS INCORPORATED	10.0.1100.470.05.0000.00	CREATIVE CLOUD ALL APPS 100GB	\$254.87
NCB	05/10/2023	1282	ADOBE SYSTEMS INCORPORATED	10.0.1100.470.05.0000.00	CREDIT FOR TAXES/CREATIVE CLOUD	(\$14.99)
NCB	05/10/2023	1282	ALDI	10.0.1100.439.00.0000.03	WHOLE MILK/GROUND CINNAMON/PURE VANILLA	\$60.56
						Check Total: \$1,420.44
7400027706	05/18/2023	1297	ALEXANDRA GEORGE	10.0.1100.300.78.0000.00	MAKEUP FOR MUSICAL	\$136.80
						Check Total: \$136.80
7400027643	05/04/2023	1273	ALEXANDRIA GILLESPIE	10.0.1100.230.00.0000.00	TUITION REIMBURSEMENT	\$805.30
						Check Total: \$805.30
NCB	05/10/2023	1282	AMAZON.COM	10.0.1100.400.11.0000.01	LABELS	\$15.95

Lincolnwood School District 74

Disbursement Detail Listing

Bank Name: COLE TAYLOR BANK - ACCOUNTS PAYABLE Date Range: 05/01/2023 - 05/31/2023 Sort By: Vendor
 Voucher Range: - Dollar Limit: \$0.00

Fiscal Year: 2022-2023

Print Employee Vendor Names
 Exclude Voided Checks
 Exclude Manual Checks
 Include Non Check Batches

Check Number	Date	Voucher	Payee	Account	Description	Amount
NCB	05/10/2023	1282	AMAZON.COM	10.0.1100.411.00.0000.03	HAND SANITIZER REFRESHING GEL	\$65.98
NCB	05/10/2023	1282	AMAZON.COM	10.0.2520.400.00.0000.00	STORAGE BIN	\$109.98
NCB	05/10/2023	1282	AMAZON.COM	10.0.1100.411.00.0000.01	KLEENEX	\$83.99
NCB	05/10/2023	1282	AMAZON.COM	10.0.1100.411.00.0000.03	MADISI GOLF PENCILS WITH ERASER	\$9.98
NCB	05/10/2023	1282	AMAZON.COM	10.0.1100.400.16.0000.03	POST-IT SUPER STICKY NOTES	\$13.69
NCB	05/10/2023	1282	AMAZON.COM	10.0.1100.410.23.0000.03	FAMILY BOARD GAME	\$41.83
NCB	05/10/2023	1282	AMAZON.COM	10.0.1100.410.23.0000.03	SAND TIMERS/HOURLASS TIMER	\$15.99
NCB	05/10/2023	1282	AMAZON.COM	10.0.1100.410.23.0000.03	TRIVIA BASED CARD GAME FOR KIDS	\$30.58
NCB	05/10/2023	1282	AMAZON.COM	10.0.1100.400.16.0000.03	CRAYOLA COLORED PENCILS CLASSPACK	\$46.72
NCB	05/10/2023	1282	AMAZON.COM	10.0.1100.400.12.0000.01	STICKERS/ERASERS/PLAY-D OH MODELING COMPOUND	\$81.12
NCB	05/10/2023	1282	AMAZON.COM	10.0.1100.400.12.0000.01	STICKERS/STORAGE CONTAINERS	\$92.65
NCB	05/10/2023	1282	AMAZON.COM	10.0.1100.400.12.0000.01	GEL PENS	\$98.82
NCB	05/10/2023	1282	AMAZON.COM	10.0.1100.411.00.0000.03	DECORATIVE PUSH PINS CORK BOARD	\$9.99
NCB	05/10/2023	1282	AMAZON.COM	10.0.1100.400.12.0000.01	COLOR CARD STOCK	\$34.82
NCB	05/10/2023	1282	AMAZON.COM	10.0.1100.300.78.0000.00	T-SHIRT	\$9.33
NCB	05/10/2023	1282	AMAZON.COM	10.0.1800.400.00.0000.01	PENCIL ERASERS	\$19.99
NCB	05/10/2023	1282	AMAZON.COM	10.0.1100.411.00.0000.01	DISPOSABLE PLASTIC	\$7.91
NCB	05/10/2023	1282	AMAZON.COM	10.0.1100.411.00.0000.03	POP UP STICKY NOTES	\$31.98
NCB	05/10/2023	1282	AMAZON.COM	10.0.1100.300.78.0000.00	TOPCOSPLAY ARIEL WIG	\$25.98
NCB	05/10/2023	1282	AMAZON.COM	10.0.1100.400.11.0000.01	ERASERS	\$62.26
NCB	05/10/2023	1282	AMAZON.COM	10.0.1100.400.11.0000.01	PUSH PIN MAGNETS	\$24.93

Lincolnwood School District 74

Disbursement Detail Listing

Bank Name: COLE TAYLOR BANK - ACCOUNTS PAYABLE Date Range: 05/01/2023 - 05/31/2023 Sort By: Vendor
 Voucher Range: - Dollar Limit: \$0.00

Fiscal Year: 2022-2023

Print Employee Vendor Names Exclude Voided Checks Exclude Manual Checks Include Non Check Batches

Check Number	Date	Voucher	Payee	Account	Description	Amount
NCB	05/10/2023	1282	AMAZON.COM	10.0.1100.410.26.0000.03	REFUND/2XVOIT COATED PLAY BALL	(\$35.20)
NCB	05/10/2023	1282	AMAZON.COM	10.0.1100.400.16.0000.03	MAGNETIC LABELS FOR WHITEBOARD	\$53.97
NCB	05/10/2023	1282	AMAZON.COM	10.0.1100.411.00.0000.03	PEEL ADDRESS LABELS	\$64.00
NCB	05/10/2023	1282	AMAZON.COM	10.0.1100.300.78.0000.00	BRISTOL NOVELTY	\$11.78
NCB	05/10/2023	1282	AMAZON.COM	10.0.1100.400.12.0000.01	BOARD ERASER	\$18.58
NCB	05/10/2023	1282	AMAZON.COM	10.0.1100.410.26.0000.03	THE SPOT TRAINING KIT	\$159.22
NCB	05/10/2023	1282	AMAZON.COM	10.0.2130.400.00.0000.01	EXAM GLOVES	\$68.99
NCB	05/10/2023	1282	AMAZON.COM	10.0.1100.300.78.0000.00	LEGGINGS/DRESS PANNIER/HAIR EXTENSION	\$68.36
NCB	05/10/2023	1282	AMAZON.COM	10.0.1100.411.00.0000.03	POP UP STICKY NOTES/BALLPOINT PENS	\$78.34
NCB	05/10/2023	1282	AMAZON.COM	10.0.1100.411.00.0000.03	REFUND/SILVER BULLETIN BOARD BORDER 2	(\$8.99)
NCB	05/10/2023	1282	AMAZON.COM	10.0.1100.400.12.0000.01	WHITE CLIPS	\$28.89
NCB	05/10/2023	1282	AMAZON.COM	10.0.1100.410.23.0000.03	FOUNDATIONS OF CHINESE CIVILIZATION	\$10.99
NCB	05/10/2023	1282	AMAZON.COM	10.0.1100.400.12.0000.01	CARDSTOCK	\$12.33
NCB	05/10/2023	1282	AMAZON.COM	10.0.2630.400.00.0000.00	REFUND/SKINNYPOP ORIGINAL POPCORN	(\$65.48)
NCB	05/10/2023	1282	AMAZON.COM	10.0.1100.450.10.0000.01	EASTER EGGS/SEEDS/PAPER PLATE	\$306.16
NCB	05/10/2023	1282	AMAZON.COM	10.0.1100.410.26.0000.03	TACHIKARA VOLLEYBALL	\$215.34
NCB	05/10/2023	1282	AMAZON.COM	10.0.1100.410.26.0000.03	REFUND/VOIT TUFF COATED FOAM HANDBALL	(\$51.97)
NCB	05/10/2023	1282	AMAZON.COM	10.0.1100.400.12.0000.01	CARDSTOCK	\$24.66
NCB	05/10/2023	1282	AMAZON.COM	10.0.1100.400.12.0000.01	WHITE CLIPS	\$28.89
NCB	05/10/2023	1282	AMAZON.COM	10.0.1100.411.00.0000.03	INKJET PRINT MULTIPURPOSE CARD	\$29.45

Lincolnwood School District 74

Disbursement Detail Listing

Bank Name: COLE TAYLOR BANK - ACCOUNTS PAYABLE Date Range: 05/01/2023 - 05/31/2023 Sort By: Vendor
 Voucher Range: - Dollar Limit: \$0.00

Fiscal Year: 2022-2023

Print Employee Vendor Names
 Exclude Voided Checks
 Exclude Manual Checks
 Include Non Check Batches

Check Number	Date	Voucher	Payee	Account	Description	Amount
NCB	05/10/2023	1282	AMAZON.COM	10.0.2410.400.00.0000.03	PENCILS WITH ERASERS	\$12.39
NCB	05/10/2023	1282	AMAZON.COM	10.0.1100.410.23.0000.03	REUSEABLE TEMPLATE FOR PAINTING/WOOD	\$9.79
NCB	05/10/2023	1282	AMAZON.COM	10.0.1100.410.23.0000.03	REGLIGIOUS EDUCATION POSTERS	\$15.57
NCB	05/10/2023	1282	AMAZON.COM	10.0.1100.410.26.0000.03	MEASURE TAPE/LIDDED TRASH CAN	\$151.32
NCB	05/10/2023	1282	AMAZON.COM	10.0.1100.410.26.0000.03	REFUND/COLOR MY CLASS GAME CONE SET	(\$33.84)
NCB	05/10/2023	1282	AMAZON.COM	10.0.1100.410.26.0000.03	REFUND/COLOR MY CLASS GAME CONE SET	(\$33.84)
NCB	05/10/2023	1282	AMAZON.COM	10.0.1100.400.12.0000.01	MATH GAMES	\$20.11
NCB	05/10/2023	1282	AMAZON.COM	10.0.1100.400.12.0000.01	CREDIT	(\$20.11)
NCB	05/10/2023	1282	AMAZON.COM	10.0.1100.400.12.0000.01	CARDSTOCK/ERASE DOTS/ERASERS	\$65.11
NCB	05/10/2023	1282	AMAZON.COM	10.0.1100.411.00.0000.03	KLEENEX	\$268.73
NCB	05/10/2023	1282	AMAZON.COM	10.0.1100.400.12.0000.01	TOPPER ERASERS	\$41.64
NCB	05/10/2023	1282	AMAZON.COM	10.0.1100.450.12.0000.01	FREEZER POPS	\$46.43
NCB	05/10/2023	1282	AMAZON.COM	10.0.2130.400.00.0000.01	CLEAR PITCHER	\$15.80
NCB	05/10/2023	1282	AMAZON.COM	10.0.2150.400.00.0000.01	CARD GAME/SQUISHY TOYS	\$332.48
NCB	05/10/2023	1282	AMAZON.COM	10.0.1100.400.11.0000.01	STICKERS	\$23.24
NCB	05/10/2023	1282	AMAZON.COM	10.0.1100.449.00.0000.02	SCENTED HIGHLIGHTERS	\$112.45
NCB	05/10/2023	1282	AMAZON.COM	10.0.2110.400.00.0000.01	SHARPIE PENS/GAMES	\$183.40
NCB	05/10/2023	1282	AMAZON.COM	10.0.1100.449.00.0000.02	SNIFF	\$109.70
NCB	05/10/2023	1282	AMAZON.COM	10.0.1100.300.78.0000.00	T-SHIRT	\$15.20
NCB	05/10/2023	1282	AMAZON.COM	10.0.1100.741.05.0000.00	LED MONITOR WITH ADAPTIVE SYNC	\$899.95
NCB	05/10/2023	1282	AMAZON.COM	10.0.2130.400.00.0000.01	SALTINE CRACKERS	\$9.76
NCB	05/10/2023	1282	AMAZON.COM	10.0.1100.410.20.0000.03	MATH POSTERS	\$25.60

Lincolnwood School District 74

Disbursement Detail Listing

Bank Name: COLE TAYLOR BANK - ACCOUNTS PAYABLE Date Range: 05/01/2023 - 05/31/2023 Sort By: Vendor
 Voucher Range: - Dollar Limit: \$0.00

Fiscal Year: 2022-2023

Print Employee Vendor Names
 Exclude Voided Checks
 Exclude Manual Checks
 Include Non Check Batches

Check Number	Date	Voucher	Payee	Account	Description	Amount
NCB	05/10/2023	1282	AMAZON.COM	10.0.1100.400.16.0000.03	CINDERELLA OUTGROWS THE GLASS SLIPPER	\$10.99
NCB	05/10/2023	1282	AMAZON.COM	10.0.1100.400.11.0000.01	PENS	\$26.04
NCB	05/10/2023	1282	AMAZON.COM	10.0.1100.449.00.0000.02	PENCILS	\$29.57
NCB	05/10/2023	1282	AMAZON.COM	10.0.1800.400.00.0000.01	STRATEGY GAME	\$27.30
NCB	05/10/2023	1282	AMAZON.COM	10.0.1100.412.05.0000.00	CABLES	\$54.42
NCB	05/10/2023	1282	AMAZON.COM	10.0.1100.741.05.0000.00	WALL MOUNTS	\$374.75
NCB	05/10/2023	1282	AMAZON.COM	10.0.1100.400.13.0000.02	PENCIL HOLDER/BRUSH ORGANIZER	\$29.99
NCB	05/10/2023	1282	AMAZON.COM	10.0.1100.411.00.0000.01	OFFICE STAPLER	\$49.86
NCB	05/10/2023	1282	AMAZON.COM	10.0.1100.410.05.0000.00	TONER	\$38.79
NCB	05/10/2023	1282	AMAZON.COM	10.0.1100.400.11.0000.01	DRY ERASE MARKERS WITH ERASER	\$11.57
NCB	05/10/2023	1282	AMAZON.COM	10.0.1100.450.12.0000.01	SIDEWALK CHALK	\$220.66
NCB	05/10/2023	1282	AMAZON.COM	10.0.1100.400.19.0000.01	THERMOMETERS	\$24.99
NCB	05/10/2023	1282	AMAZON.COM	10.0.1100.449.00.0000.02	PAPERBACK BOXED SET	\$43.76
NCB	05/10/2023	1282	AMAZON.COM	10.0.1100.400.13.0000.02	BOOKMARKS/POCKET	\$98.69
NCB	05/10/2023	1282	AMAZON.COM	10.0.1100.449.00.0000.02	SMENCILS CYLINDER	\$199.47
NCB	05/10/2023	1282	AMAZON.COM	10.0.2150.400.00.0000.01	STICKERS/POP FIDGET DEYCHAIN	\$36.85
NCB	05/10/2023	1282	AMAZON.COM	10.0.1100.411.00.0000.01	METALLIC STICKERS	\$5.79
NCB	05/10/2023	1282	AMAZON.COM	10.0.1100.411.00.0000.02	KLEENEX	\$274.40
NCB	05/10/2023	1282	AMAZON.COM	10.0.1100.410.22.0000.01	LETTER NAME	\$18.00
NCB	05/10/2023	1282	AMAZON.COM	10.0.1100.410.22.0000.01	CREDIT	(\$18.00)
NCB	05/10/2023	1282	AMAZON.COM	10.0.1100.449.00.0000.01	HANGING SHOE ORGANIZER	\$44.35
NCB	05/10/2023	1282	AMAZON.COM	10.0.1100.449.00.0000.02	WIRELESS EARBUDS	\$33.57
NCB	05/10/2023	1282	AMAZON.COM	10.0.1100.411.00.0000.02	STICKY NOTES/STAPLER	\$48.61
NCB	05/10/2023	1282	AMAZON.COM	10.0.1100.400.19.0000.01	PROJECT BRICKS	\$26.64
NCB	05/10/2023	1282	AMAZON.COM	10.0.1100.400.19.0000.01	MASKING TAPE	\$50.88
NCB	05/10/2023	1282	AMAZON.COM	10.0.2110.400.00.0000.01	WORLD OF KIDS EMOTIONS	\$44.99

Lincolnwood School District 74

Disbursement Detail Listing

Bank Name: COLE TAYLOR BANK - ACCOUNTS PAYABLE Date Range: 05/01/2023 - 05/31/2023 Sort By: Vendor
 Voucher Range: - Dollar Limit: \$0.00

Fiscal Year: 2022-2023

Print Employee Vendor Names
 Exclude Voided Checks
 Exclude Manual Checks
 Include Non Check Batches

Check Number	Date	Voucher	Payee	Account	Description	Amount
NCB	05/10/2023	1282	AMAZON.COM	10.0.1100.400.10.0000.01	PREMIUM CARDSTOCK	\$14.98
NCB	05/10/2023	1282	AMAZON.COM	10.0.1100.449.00.0000.02	PENS/FIDGET TOYS/HIGHLIGHTERS	\$126.10
NCB	05/10/2023	1282	AMAZON.COM	10.0.1100.449.00.0000.02	ERASERS	\$7.98
NCB	05/10/2023	1282	AMAZON.COM	10.0.1100.410.24.0000.02	WIG PINS WITH A PLASTIC BOX	\$17.98
NCB	05/10/2023	1282	AMAZON.COM	10.0.1800.400.00.0000.01	KAWAII SQUISHY TOYS	\$79.47
NCB	05/10/2023	1282	AMAZON.COM	10.0.1100.400.13.0000.02	FLOWER SEED PACKETS	\$68.97
NCB	05/10/2023	1282	AMAZON.COM	10.0.1100.400.11.0000.01	SCRATCH AND SNIFF BOOKMARKS	\$95.44
NCB	05/10/2023	1282	AMAZON.COM	10.0.1100.400.10.0000.01	PREMIUM CARDSTOCK	\$14.98
NCB	05/10/2023	1282	AMAZON.COM	10.0.1100.450.12.0000.01	BUBBLE BLOWER BOTTLES	\$119.94
NCB	05/10/2023	1282	AMAZON.COM	10.0.1200.400.00.0000.01	PRE KINDERGARTEN ACTIVITY WORKSHEET	\$6.99
NCB	05/10/2023	1282	AMAZON.COM	10.0.1100.410.24.0000.01	WASHABLE WATERCOLORS	\$160.00
NCB	05/10/2023	1282	AMAZON.COM	10.0.1100.410.24.0000.02	WHITE CLIPS/BUSINESS CARDS	\$31.88
NCB	05/10/2023	1282	AMAZON.COM	10.0.2150.400.00.0000.01	EDUCATIONAL GAME	\$40.00
NCB	05/10/2023	1282	AMAZON.COM	10.0.1100.400.18.0000.03	STICKY EASEL PAD	\$67.18
NCB	05/10/2023	1282	AMAZON.COM	10.0.1100.400.11.0000.01	SNIFF STINKY STICKERS	\$10.20
NCB	05/10/2023	1282	AMAZON.COM	10.0.1100.449.00.0000.02	SMENCILS CULINDER	\$390.54
NCB	05/10/2023	1282	AMAZON.COM	10.0.1100.410.24.0000.02	ART ACHIEVEMENT CERTIFICATE	\$39.52
NCB	05/10/2023	1282	AMAZON.COM	10.0.1125.450.09.0000.01	STRATEGY GAME	\$27.30
NCB	05/10/2023	1282	AMAZON.COM	10.0.2150.400.00.0000.01	ALPHABET GAME	\$29.32
NCB	05/10/2023	1282	AMAZON.COM	10.0.1100.400.19.0000.01	PAPER/POM POMS	\$32.75
NCB	05/10/2023	1282	AMAZON.COM	10.0.1800.400.00.0000.01	STICKERS	\$3.99
NCB	05/10/2023	1282	AMAZON.COM	10.0.1125.450.09.0000.01	CREATIVE STRAW TOYS	\$153.86
NCB	05/10/2023	1282	AMAZON.COM	10.0.1100.410.24.0000.02	PICTURE MAT	\$14.25
NCB	05/10/2023	1282	AMAZON.COM	10.0.2520.400.00.0000.00	FACIL TISSUE	\$83.99

Lincolnwood School District 74

Disbursement Detail Listing

Bank Name: COLE TAYLOR BANK - ACCOUNTS PAYABLE Date Range: 05/01/2023 - 05/31/2023 Sort By: Vendor
 Voucher Range: - Dollar Limit: \$0.00

Fiscal Year: 2022-2023

Print Employee Vendor Names
 Exclude Voided Checks
 Exclude Manual Checks
 Include Non Check Batches

Check Number	Date	Voucher	Payee	Account	Description	Amount
NCB	05/10/2023	1282	AMAZON.COM	10.0.1100.400.18.0000.03	PENCILS	\$86.89
NCB	05/10/2023	1282	AMAZON.COM	10.0.1200.400.00.0000.01	BUILDING BLOCKS	\$238.48
NCB	05/10/2023	1282	AMAZON.COM	10.0.2150.400.00.0000.01	BIRTHDAY PARTY FAVORS	\$23.00
NCB	05/10/2023	1282	AMAZON.COM	10.0.1100.449.00.0000.02	HELMET/BLUETOOTH	\$522.20
NCB	05/10/2023	1282	AMAZON.COM	10.0.1800.400.00.0000.02	BOOKS	\$92.17
NCB	05/10/2023	1282	AMAZON.COM	10.0.1100.410.24.0000.01	PAINT STICKS	\$131.32
NCB	05/10/2023	1282	AMAZON.COM	10.0.1100.449.00.0000.02	PENCILS	\$59.14
NCB	05/10/2023	1282	AMAZON.COM	10.0.1100.449.00.0000.02	FIDGET SPINNERS	\$75.91
NCB	05/10/2023	1282	AMAZON.COM	10.0.2410.400.00.0000.02	SQUEEZE BALLS/BUBBLE FIDGET SENSORY	\$158.93
NCB	05/10/2023	1282	AMAZON.COM	10.0.1100.410.24.0000.01	MODELING CLAY/PAINT STICKS	\$713.48
NCB	05/10/2023	1282	AMAZON.COM	10.0.1100.400.11.0000.01	ERASE MARKERS	\$35.09
NCB	05/10/2023	1282	AMAZON.COM	10.0.1100.410.24.0000.01	WASHABLE PAINT	\$94.12
NCB	05/10/2023	1282	AMAZON.COM	10.0.1800.400.00.4909.00	ORIGINAL POPCORN	\$62.08
NCB	05/10/2023	1282	AMAZON.COM	10.0.2150.400.00.0000.01	GAME FOR KIDS	\$20.85
NCB	05/10/2023	1282	AMAZON.COM	10.0.1125.450.09.0000.01	MOTOR GAME	\$26.74
NCB	05/10/2023	1282	AMAZON.COM	10.0.1100.400.11.0000.01	PERMANENT MARKERS	\$17.90
NCB	05/10/2023	1282	AMAZON.COM	10.0.1100.400.19.0000.01	PAPER LUNCH BAGS/INDEX CARDS	\$565.04
NCB	05/10/2023	1282	AMAZON.COM	10.0.1100.400.16.0000.03	SLAP BRACELETS	\$8.99
NCB	05/10/2023	1282	AMAZON.COM	10.0.2130.400.00.0000.02	ZIP PLASTIC POLY BAGS/TISSUE	\$68.29
NCB	05/10/2023	1282	AMAZON.COM	10.0.1800.400.00.4909.00	EL BOOK BUNDLE	\$1,645.74
NCB	05/10/2023	1282	AMAZON.COM	10.0.1100.300.78.0000.00	FISHING NET	\$39.50
NCB	05/10/2023	1282	AMAZON.COM	10.0.1100.410.26.0000.03	CORNHOLE SET	\$341.94
NCB	05/10/2023	1282	AMAZON.COM	10.0.1100.471.00.0000.03	BLUETOOTH OUTDOOR	\$189.00
NCB	05/10/2023	1282	AMAZON.COM	10.0.1800.400.00.4909.00	EL BOOK BUNDLE	\$206.70
NCB	05/10/2023	1282	AMAZON.COM	10.0.1250.401.00.4300.00	EL BOOK BUNDLE	\$842.38

Lincolnwood School District 74

Disbursement Detail Listing

Bank Name: COLE TAYLOR BANK - ACCOUNTS PAYABLE Date Range: 05/01/2023 - 05/31/2023 Sort By: Vendor
 Voucher Range: - Dollar Limit: \$0.00

Fiscal Year: 2022-2023

Print Employee Vendor Names
 Exclude Voided Checks
 Exclude Manual Checks
 Include Non Check Batches

Check Number	Date	Voucher	Payee	Account	Description	Amount
NCB	05/10/2023	1282	AMAZON.COM	10.0.2630.400.00.0000.00	REFUND/RETURN SPELLING BEE BALLOONS	(\$5.36)
NCB	05/10/2023	1282	AMAZON.COM	10.0.1100.400.10.0000.01	CREDIT	(\$98.78)
NCB	05/10/2023	1282	AMAZON.COM	10.0.1800.400.00.4909.00	EL BOOK BUNDLE	\$482.77
NCB	05/10/2023	1282	AMAZON.COM	10.0.2520.400.00.0000.00	INK PENS	\$21.80
NCB	05/10/2023	1282	AMAZON.COM	10.0.1800.400.00.4909.00	EL BOOK BUNDLE	\$779.48
NCB	05/10/2023	1282	AMAZON.COM	10.0.1800.400.00.4909.00	EL BOOK BUNDLE	\$78.60
NCB	05/10/2023	1282	AMAZON.COM	10.0.1800.400.00.4909.00	EL BOOK BUNDLE	\$141.30
NCB	05/10/2023	1282	AMAZON.COM	10.0.2150.400.00.0000.03	INFERENCE ACTIVITIES 2ND EDITION	\$17.00
NCB	05/10/2023	1282	AMAZON.COM	10.0.1100.410.26.0000.03	PORTABLE PICKLEBALL NET SYSTEM	\$179.99
NCB	05/10/2023	1282	AMAZON.COM	10.0.1800.400.00.4909.00	EL BOOK BUNDLE	\$795.20
NCB	05/10/2023	1282	AMAZON.COM	10.0.1800.400.00.4909.00	EL BOOK BUNDLE	\$1,299.74
NCB	05/10/2023	1282	AMAZON.COM	10.0.2520.400.00.0000.00	SMEAD COLORED FILE	\$23.70
NCB	05/10/2023	1282	AMAZON.COM	10.0.2520.400.00.0000.00	REPLACEMENT INK PAD	\$7.45
NCB	05/10/2023	1282	AMAZON.COM	10.0.2520.400.00.0000.00	POST-IT POP-UP NOTES	\$56.36
NCB	05/10/2023	1282	AMAZON.COM	10.0.1250.401.00.4300.00	EL BOOK BUNDLE/1ST GR	\$1,392.42
NCB	05/10/2023	1282	AMAZON.COM	10.0.1800.400.00.4909.00	EL BOOK BUNDLE	\$739.05
NCB	05/10/2023	1282	AMAZON.COM	10.0.1100.300.78.0000.00	NOVELTY TOP HAT	\$9.00
NCB	05/10/2023	1282	AMAZON.COM	10.0.1100.300.78.0000.00	CELLOPHANE WRAP	\$157.35
NCB	05/10/2023	1282	AMAZON.COM	10.0.1800.400.00.4909.00	EL BOOK BUNDLE	\$378.84
NCB	05/10/2023	1282	AMAZON.COM	10.0.2520.400.00.0000.00	PEN Z-GRIP	\$15.88
NCB	05/10/2023	1282	AMAZON.COM	10.0.1800.400.00.4909.00	EL BOOK BUNDLE	\$359.80
NCB	05/10/2023	1282	AMAZON.COM	10.0.1100.400.12.0000.01	MESH ZIPPER POUCH	\$10.85
NCB	05/10/2023	1282	AMAZON.COM	10.0.1250.401.00.4300.00	EL BOOK BUNDLE	\$736.82
NCB	05/10/2023	1282	AMAZON.COM	10.0.1800.400.00.4909.00	EL BOOK BUNDLE	\$141.30
NCB	05/10/2023	1282	AMAZON.COM	10.0.1800.400.00.4909.00	EL BOOK BUNDLE	\$378.84
NCB	05/10/2023	1282	AMAZON.COM	10.0.1800.400.00.4909.00	EL BOOK BUNDLE	\$216.48
NCB	05/10/2023	1282	AMAZON.COM	10.0.1100.400.10.0000.01	MAGNETIC STRIP	\$21.48

Lincolnwood School District 74

Disbursement Detail Listing

Bank Name: COLE TAYLOR BANK - ACCOUNTS PAYABLE Date Range: 05/01/2023 - 05/31/2023 Sort By: Vendor
 Voucher Range: - Dollar Limit: \$0.00

Fiscal Year: 2022-2023

Print Employee Vendor Names
 Exclude Voided Checks
 Exclude Manual Checks
 Include Non Check Batches

Check Number	Date	Voucher	Payee	Account	Description	Amount
NCB	05/10/2023	1282	AMAZON.COM	10.0.1100.404.00.0000.03	PAPER	\$74.97
NCB	05/10/2023	1282	AMAZON.COM	10.0.1100.400.10.0000.01	CRAYOLA WASHABLE PAINT	\$55.01
NCB	05/10/2023	1282	AMAZON.COM	10.0.1100.400.10.0000.01	WASHABLE PAINT MARKERS	\$103.03
NCB	05/10/2023	1282	AMAZON.COM	10.0.2310.340.00.0000.00	PAIR/CANDLESTICKS	\$91.39
NCB	05/10/2023	1282	AMAZON.COM	10.0.1100.400.10.0000.01	SENTENCE STRIPS	\$25.04
NCB	05/10/2023	1282	AMAZON.COM	10.0.1100.400.10.0000.01	FRAME POP BOARD	\$21.98
NCB	05/10/2023	1282	AMAZON.COM	10.0.1100.400.10.0000.01	REUSEABLE ICE CREAM STRAWS/S	\$23.90
NCB	05/10/2023	1282	AMAZON.COM	10.0.1100.400.10.0000.01	CRAYOLA WASHABLE PAINT	\$12.22
NCB	05/10/2023	1282	AMAZON.COM	10.0.1100.400.10.0000.01	PACKAGING TAPE	\$24.44
NCB	05/10/2023	1282	AMAZON.COM	10.0.1100.400.10.0000.01	MAGNET TAPE	\$63.49
NCB	05/10/2023	1282	AMAZON.COM	10.0.1100.400.10.0000.01	STINKY STICKERS	\$17.31
NCB	05/10/2023	1282	AMAZON.COM	10.0.1100.400.10.0000.01	ADDRESS LABELS	\$44.25
NCB	05/10/2023	1282	AMAZON.COM	10.0.1100.400.11.0000.01	TONE CRAYONS/	\$33.49
NCB	05/10/2023	1282	AMAZON.COM	10.0.1100.400.10.0000.01	STIKKICLIPS PLASTIC	\$13.55
NCB	05/10/2023	1282	AMAZON.COM	10.0.1100.400.11.0000.01	WASHABLE MARKERS	\$25.49
NCB	05/10/2023	1282	AMAZON.COM	10.0.1100.400.10.0000.01	REUSABLE ICE CREAM STRAWS/WASHABLE PAINT	\$20.48
NCB	05/10/2023	1282	AMAZON.COM	10.0.1100.450.10.0000.01	PLASTIC BAGS/TABLE CONFETTI	\$61.94
NCB	05/10/2023	1282	AMAZON.COM	10.0.1100.400.10.0000.01	RUG PAD GRIPPER	\$23.27
NCB	05/10/2023	1282	AMAZON.COM	10.0.1100.400.10.0000.01	BRAIN FLAKES/CLOTHESPINS/NAM	\$34.87
NCB	05/10/2023	1282	AMAZON.COM	10.0.2310.340.00.0000.00	GIFT CARD	\$50.00
NCB	05/10/2023	1282	AMAZON.COM	10.0.1100.400.10.0000.01	SENTENCE STRIPS	\$25.04
NCB	05/10/2023	1282	AMAZON.COM	20.0.2540.404.00.0000.03	WIRE TIES	\$24.94
NCB	05/10/2023	1282	AMAZON.COM	10.0.1100.450.10.0000.01	PATRIOTIC PARTY WRISTBAND PARTY	\$421.09
NCB	05/10/2023	1282	AMAZON.COM	10.0.1100.400.10.0000.01	ADDRESS LABELS	\$22.09
NCB	05/10/2023	1282	AMAZON.COM	10.0.1100.400.10.0000.01	WASHABLE PAINT	\$55.01

Lincolnwood School District 74

Disbursement Detail Listing

Bank Name: COLE TAYLOR BANK - ACCOUNTS PAYABLE Date Range: 05/01/2023 - 05/31/2023 Sort By: Vendor
 Voucher Range: - Dollar Limit: \$0.00

Fiscal Year: 2022-2023

Print Employee Vendor Names
 Exclude Voided Checks
 Exclude Manual Checks
 Include Non Check Batches

Check Number	Date	Voucher	Payee	Account	Description	Amount
NCB	05/10/2023	1282	AMAZON.COM	10.0.1100.300.78.0000.00	INFLATABLE BOUNCY BALLS WITH HAND AIR PUMP & 2	\$61.98
NCB	05/10/2023	1282	AMAZON.COM	10.0.1100.400.10.0000.01	ADDRESS LABELS	\$44.25
NCB	05/10/2023	1282	AMAZON.COM	10.0.1100.450.10.0000.01	COLORED CARDSTOCK	\$228.54
NCB	05/10/2023	1282	AMAZON.COM	10.0.1100.450.10.0000.01	REFUND	(\$34.98)
NCB	05/10/2023	1282	AMAZON.COM	10.0.1100.400.10.0000.01	COLORED PAPER	\$91.96
NCB	05/10/2023	1282	AMAZON.COM	10.0.1100.400.10.0000.01	RETURNED/COLORED PAPER	(\$16.49)
NCB	05/10/2023	1282	AMAZON.COM	10.0.1100.423.36.0000.03	NONSTICK GRIDDLE PAN/FLAT GRILL	\$59.85
NCB	05/10/2023	1282	AMAZON.COM	10.0.1100.400.10.0000.01	PAINT MARKERS/PAPER BULLETIN BOARD ROLL	\$72.98
NCB	05/10/2023	1282	AMAZON.COM	10.0.1100.400.10.0000.01	ADDRESS LABELS	\$22.09
NCB	05/10/2023	1282	AMAZON.COM	10.0.1100.400.10.0000.01	SENTENCE STRIPS	\$17.69
NCB	05/10/2023	1282	AMAZON.COM	10.0.1100.400.10.0000.01	MAGNETS	\$17.74
NCB	05/10/2023	1282	AMAZON.COM	10.0.1100.400.10.0000.01	SENTENCE STRIPS	\$25.04
NCB	05/10/2023	1282	AMAZON.COM	10.0.1100.400.10.0000.01	PERMANENT MARKERS	\$35.17
NCB	05/10/2023	1282	AMAZON.COM	10.0.1100.400.10.0000.01	STAMP PAD/SIGN HOLDER/STICKY NOTES	\$129.66
NCB	05/10/2023	1282	AMAZON.COM	10.0.1100.450.10.0000.01	REFUND	(\$16.49)
NCB	05/10/2023	1282	AMAZON.COM	10.0.1100.450.11.0000.01	BUBBLE WANDS	\$285.30
NCB	05/10/2023	1282	AMAZON.COM	10.0.1100.411.00.0000.03	PAINT MARKER PENS	\$9.89
NCB	05/10/2023	1282	AMAZON.COM	10.0.1100.400.11.0000.01	DRY ERASE POCKET SLEEVES	\$46.45
NCB	05/10/2023	1282	AMAZON.COM	10.0.1100.400.19.0000.03	REPLACEMENT BATTERY WITH RECHARGEABLE	\$80.97
NCB	05/10/2023	1282	AMAZON.COM	10.0.1100.400.10.0000.01	PACKAGING TAPE/PENCIL SHARPENER	\$145.72
NCB	05/10/2023	1282	AMAZON.COM	10.0.1100.400.10.0000.01	SENTENCE STRIPS	\$25.04
NCB	05/10/2023	1282	AMAZON.COM	10.0.1100.400.10.0000.01	WASHABLE MARKERS	\$70.38
NCB	05/10/2023	1282	AMAZON.COM	10.0.1100.400.10.0000.01	NAMEPLATE POCKETS	\$10.87
NCB	05/10/2023	1282	AMAZON.COM	10.0.1100.400.10.0000.01	RUG PAD GRIPPER	\$11.99

Lincolnwood School District 74

Disbursement Detail Listing

Bank Name: COLE TAYLOR BANK - ACCOUNTS PAYABLE

Date Range: 05/01/2023 - 05/31/2023

Sort By: Vendor

Fiscal Year: 2022-2023

Voucher Range: -

Dollar Limit: \$0.00

Print Employee Vendor Names

Exclude Voided Checks

Exclude Manual Checks

Include Non Check Batches

Check Number	Date	Voucher	Payee	Account	Description	Amount	
NCB	05/10/2023	1282	AMAZON.COM	10.0.1100.400.10.0000.01	STIKKICLIPS PLASTIC	\$13.55	
NCB	05/10/2023	1282	AMAZON.COM	10.0.1100.400.11.0000.01	PERMANENT MARKER	\$7.69	
NCB	05/10/2023	1282	AMAZON.COM	10.0.1100.400.10.0000.01	PERMANENT MARKERS	\$13.19	
NCB	05/10/2023	1282	AMAZON.COM	10.0.1100.400.10.0000.01	STAPLE REMOVER	\$5.87	
NCB	05/10/2023	1282	AMAZON.COM	10.0.1100.400.10.0000.01	STORAGE BOX	\$26.99	
NCB	05/10/2023	1282	AMAZON.COM	10.0.1100.400.10.0000.01	CLIPS	\$12.65	
NCB	05/10/2023	1282	AMAZON.COM	10.0.2520.400.00.0000.00	CARDSTOCK	\$24.38	
NCB	05/10/2023	1282	AMAZON.COM	20.0.2540.404.00.0000.03	WIRE TIES	\$32.94	
NCB	05/10/2023	1282	AMAZON.COM	10.0.1100.400.10.0000.01	WASHABLE PAINT	\$55.01	
NCB	05/10/2023	1282	AMAZON.COM	10.0.2130.400.00.0000.01	SALTINE CRACKERS	\$26.00	
NCB	05/10/2023	1282	AMAZON.COM	10.0.1100.400.10.0000.01	ERASE MARKERS	\$18.49	
NCB	05/10/2023	1282	AMAZON.COM	10.0.1100.400.10.0000.01	CORRECTION TAPE PEN	\$8.98	
NCB	05/10/2023	1282	AMAZON.COM	10.0.1100.450.57.0000.03	POT HOLDERS/KITCHEN	\$14.69	
NCB	05/12/2023	1295	AMERIPRISE FINANCIAL SERVICES INC.	10.3.0499.500.00.0000.00	ANNUITIES PAYABLE	\$980.73	
						Check Total:	\$26,306.49
7400027644	05/04/2023	1273	AMY SENIOR	10.0.2310.300.00.0000.00	TECH SERVICE-BOE 5/4/23	\$80.00	
						Check Total:	\$80.00
NCB	05/10/2023	1282	ANCHORFISH PRINTING	10.0.1100.300.78.0000.00	T-SHIRTS	\$1,459.24	
						Check Total:	\$1,459.24
7400027707	05/18/2023	1297	ANDERSON LOCK	20.0.2540.320.00.0000.03	CYLINDER	\$1,114.32	
						Check Total:	\$1,114.32
7400027708	05/18/2023	1297	ANDREW MACCRIMMON	10.0.1100.300.78.0000.00	LH MUSICAL STIPEND FOR STAGE DESIGN	\$1,025.75	
						Check Total:	\$1,025.75
7400027645	05/04/2023	1273	APPLE INC	10.0.1100.310.05.0000.00	3-Year AppleCare+ for Schools - iMac	\$119.00	
7400027645	05/04/2023	1273	APPLE INC	10.0.1100.551.05.0000.00	24-inch iMac with Retina 4.5K display	\$1,249.00	
7400027645	05/04/2023	1273	APPLE INC	10.0.1100.310.05.0000.00	3-Year AppleCare+ for Schools - MacBook Air M2	\$7,155.00	

Lincolnwood School District 74

Disbursement Detail Listing

Bank Name: COLE TAYLOR BANK - ACCOUNTS PAYABLE Date Range: 05/01/2023 - 05/31/2023 Sort By: Vendor
 Voucher Range: - Dollar Limit: \$0.00

Fiscal Year: 2022-2023

Print Employee Vendor Names Exclude Voided Checks Exclude Manual Checks Include Non Check Batches

Check Number	Date	Voucher	Payee	Account	Description	Amount	
7400027645	05/04/2023	1273	APPLE INC	10.0.1100.551.05.0000.00	MacBook Air: M2, 256GB 3-YR AC+ 5-pack	\$0.00	
7400027645	05/04/2023	1273	APPLE INC	10.0.1100.551.05.0000.00	13-inch MacBook Air: Apple M2 chip with 8-core CPU	\$48,555.00	
7400027645	05/04/2023	1273	APPLE INC	10.0.1100.310.05.0000.00	AC+ D575768938	\$49.00	
7400027645	05/04/2023	1273	APPLE INC	10.0.1100.310.05.0000.00	AC+ D578192887	\$49.00	
7400027645	05/04/2023	1273	APPLE INC	10.0.1100.741.05.0000.00	Mac mini: Apple M2 chip with 8-core CPU and	\$14,370.00	
						Check Total:	\$71,546.00
NCB	05/10/2023	1282	APPLE.COM	10.0.1100.316.05.0000.00	LAMP WORDS FOR LIFE	\$599.96	
						Check Total:	\$599.96
7400027709	05/18/2023	1297	AT&T	20.0.2540.340.00.0000.00	TELEPHONE	\$265.81	
						Check Total:	\$265.81
7400027710	05/18/2023	1297	AT&T-3	20.0.2540.340.00.0000.00	TELEPHONE	\$378.69	
7400027710	05/18/2023	1297	AT&T-3	20.0.2540.340.00.0000.00	TELEPHONE	\$388.17	
7400027710	05/18/2023	1297	AT&T-3	20.0.2540.340.00.0000.00	TELEPHONE	\$1,391.00	
						Check Total:	\$2,157.86
7400027646	05/04/2023	1273	AWARD EMBLEM MFTG. CO., INC.	10.0.1100.425.00.0000.03	No. 2-Band	\$53.30	
7400027646	05/04/2023	1273	AWARD EMBLEM MFTG. CO., INC.	10.0.1100.425.00.0000.03	No. 2-Orchestra	\$66.63	
7400027646	05/04/2023	1273	AWARD EMBLEM MFTG. CO., INC.	10.0.1100.425.00.0000.03	No. 5 Guard- 5Years	\$4.95	
7400027646	05/04/2023	1273	AWARD EMBLEM MFTG. CO., INC.	10.0.1100.425.00.0000.03	No. 5-4Years	\$4.95	
7400027646	05/04/2023	1273	AWARD EMBLEM MFTG. CO., INC.	10.0.1100.425.00.0000.03	No. 5-1Years	\$4.95	
7400027646	05/04/2023	1273	AWARD EMBLEM MFTG. CO., INC.	10.0.1100.425.00.0000.03	No. 233 Violin	\$379.10	
7400027646	05/04/2023	1273	AWARD EMBLEM MFTG. CO., INC.	10.0.1100.425.00.0000.03	No. 286 Cello	\$50.55	
7400027646	05/04/2023	1273	AWARD EMBLEM MFTG. CO., INC.	10.0.1100.425.00.0000.03	No. 214 Bass Pin	\$50.55	
7400027646	05/04/2023	1273	AWARD EMBLEM MFTG. CO., INC.	10.0.1100.425.00.0000.03	No. 218 Flute Pin	\$80.87	

Lincolnwood School District 74

Disbursement Detail Listing

Bank Name: COLE TAYLOR BANK - ACCOUNTS PAYABLE Date Range: 05/01/2023 - 05/31/2023 Sort By: Vendor
 Voucher Range: - Dollar Limit: \$0.00

Fiscal Year: 2022-2023

Print Employee Vendor Names Exclude Voided Checks Exclude Manual Checks Include Non Check Batches

Check Number	Date	Voucher	Payee	Account	Description	Amount
7400027646	05/04/2023	1273	AWARD EMBLEM MFTG. CO., INC.	10.0.1100.425.00.0000.03	No. 216 Clarinet Pin	\$55.60
7400027646	05/04/2023	1273	AWARD EMBLEM MFTG. CO., INC.	10.0.1100.425.00.0000.03	No. 228 Sax Pin	\$40.44
7400027646	05/04/2023	1273	AWARD EMBLEM MFTG. CO., INC.	10.0.1100.425.00.0000.03	No. 232 Trumpet Pin	\$121.31
7400027646	05/04/2023	1273	AWARD EMBLEM MFTG. CO., INC.	10.0.1100.425.00.0000.03	No. 219 Fhorn Pin	\$15.16
7400027646	05/04/2023	1273	AWARD EMBLEM MFTG. CO., INC.	10.0.1100.425.00.0000.03	No. 231 Trombone Pin	\$40.44
7400027646	05/04/2023	1273	AWARD EMBLEM MFTG. CO., INC.	10.0.1100.425.00.0000.03	No. 213 Baritone Pin	\$25.27
7400027646	05/04/2023	1273	AWARD EMBLEM MFTG. CO., INC.	10.0.1100.425.00.0000.03	No. 217 Drum Pin	\$85.93
7400027646	05/04/2023	1273	AWARD EMBLEM MFTG. CO., INC.	10.0.1100.425.00.0000.03	ENGRAVE	\$28.43
Check Total:						\$1,108.43
NCB	05/12/2023	1295	AXA EQUITABLE PAYMENT CENTER	10.3.0499.500.00.0000.00	ANNUITIES PAYABLE	\$1,050.00
NCB	05/12/2023	1295	AXA EQUITABLE PAYMENT CENTER	10.3.0499.500.00.0000.00	ANNUITIES PAYABLE	\$1,310.00
NCB	05/12/2023	1295	AXA EQUITABLE PAYMENT CENTER	10.3.0499.500.00.0000.00	ANNUITIES PAYABLE	\$9,948.64
Check Total:						\$12,308.64
7400027647	05/04/2023	1273	BOB'S DAIRY SERVICE	10.0.2560.415.00.0000.00	LOW FAT	\$12.70
7400027647	05/04/2023	1273	BOB'S DAIRY SERVICE	10.0.2560.415.00.0000.00	SKIM CHOCOLATE	\$40.16
7400027647	05/04/2023	1273	BOB'S DAIRY SERVICE	10.0.2560.415.00.0000.00	LOW FAT	\$12.70
7400027647	05/04/2023	1273	BOB'S DAIRY SERVICE	10.0.2560.415.00.0000.00	SKIM CHOCOLATE	\$53.54
7400027647	05/04/2023	1273	BOB'S DAIRY SERVICE	10.0.2560.415.00.0000.00	SKIM CHOCOLATE	\$26.77
7400027647	05/04/2023	1273	BOB'S DAIRY SERVICE	10.0.2560.415.00.0000.00	SKIM CHOCOLATE	\$53.54
7400027647	05/04/2023	1273	BOB'S DAIRY SERVICE	10.0.2560.415.00.0000.00	SKIM CHOCOLATE	\$40.16
7400027647	05/04/2023	1273	BOB'S DAIRY SERVICE	10.0.2560.415.00.0000.00	SKIM CHOCOLATE	\$66.93
7400027647	05/04/2023	1273	BOB'S DAIRY SERVICE	10.0.2560.415.00.0000.00	LOW FAT	\$12.90
7400027647	05/04/2023	1273	BOB'S DAIRY SERVICE	10.0.2560.415.00.0000.00	SKIM CHOCOLATE	\$40.76
7400027647	05/04/2023	1273	BOB'S DAIRY SERVICE	10.0.2560.415.00.0000.00	LOW FAT	\$12.90
7400027647	05/04/2023	1273	BOB'S DAIRY SERVICE	10.0.2560.415.00.0000.00	SKIM CHOCOLATE	\$81.51

Lincolnwood School District 74

Disbursement Detail Listing

Bank Name: COLE TAYLOR BANK - ACCOUNTS PAYABLE Date Range: 05/01/2023 - 05/31/2023 Sort By: Vendor
 Voucher Range: - Dollar Limit: \$0.00

Fiscal Year: 2022-2023

Print Employee Vendor Names Exclude Voided Checks Exclude Manual Checks Include Non Check Batches

Check Number	Date	Voucher	Payee	Account	Description	Amount
7400027647	05/04/2023	1273	BOB'S DAIRY SERVICE	10.0.2560.415.00.0000.00	SKIM CHOCOLATE	\$40.76
7400027647	05/04/2023	1273	BOB'S DAIRY SERVICE	10.0.2560.415.00.0000.00	LOW FAT	\$25.80
7400027647	05/04/2023	1273	BOB'S DAIRY SERVICE	10.0.2560.415.00.0000.00	SKIM CHOCOLATE	\$122.27
7400027647	05/04/2023	1273	BOB'S DAIRY SERVICE	10.0.2560.415.00.0000.00	LOW FAT	\$12.90
7400027647	05/04/2023	1273	BOB'S DAIRY SERVICE	10.0.2560.415.00.0000.00	SKIM CHOCOLATE	\$122.27
7400027647	05/04/2023	1273	BOB'S DAIRY SERVICE	10.0.2560.415.00.0000.00	LOW FAT	\$12.90
7400027647	05/04/2023	1273	BOB'S DAIRY SERVICE	10.0.2560.415.00.0000.00	SKIM CHOCOLATE	\$67.93
Check Total:						\$859.40
7400027711	05/18/2023	1297	BOB'S DAIRY SERVICE	10.0.2560.415.00.0000.00	SKIM CHOCOLATE	\$67.93
7400027711	05/18/2023	1297	BOB'S DAIRY SERVICE	10.0.2560.415.00.0000.00	LOW FAT	\$12.90
7400027711	05/18/2023	1297	BOB'S DAIRY SERVICE	10.0.2560.415.00.0000.00	SKIM CHOCOLATE	\$81.51
7400027711	05/18/2023	1297	BOB'S DAIRY SERVICE	10.0.2560.415.00.0000.00	SKIM CHOCOLATE	\$67.93
7400027711	05/18/2023	1297	BOB'S DAIRY SERVICE	10.0.2560.415.00.0000.00	LOW FAT	\$25.80
7400027711	05/18/2023	1297	BOB'S DAIRY SERVICE	10.0.2560.415.00.0000.00	SKIM CHOCOLATE	\$122.27
7400027711	05/18/2023	1297	BOB'S DAIRY SERVICE	10.0.2560.415.00.0000.00	LOW FAT	\$12.90
7400027711	05/18/2023	1297	BOB'S DAIRY SERVICE	10.0.2560.415.00.0000.00	SKIM CHOCOLATE	\$122.27
7400027711	05/18/2023	1297	BOB'S DAIRY SERVICE	10.0.2560.415.00.0000.00	SKIM CHOCOLATE	\$54.34
7400027711	05/18/2023	1297	BOB'S DAIRY SERVICE	10.0.2560.415.00.0000.00	LOW FAT	\$12.90
7400027711	05/18/2023	1297	BOB'S DAIRY SERVICE	10.0.2560.415.00.0000.00	SKIM CHOCOLATE	\$81.51
7400027711	05/18/2023	1297	BOB'S DAIRY SERVICE	10.0.2560.415.00.0000.00	LOW FAT	\$12.90
7400027711	05/18/2023	1297	BOB'S DAIRY SERVICE	10.0.2560.415.00.0000.00	SKIM CHOCOLATE	\$54.34
7400027711	05/18/2023	1297	BOB'S DAIRY SERVICE	10.0.2560.415.00.0000.00	LOW FAT	\$12.90
7400027711	05/18/2023	1297	BOB'S DAIRY SERVICE	10.0.2560.415.00.0000.00	SKIM CHOCOLATE	\$54.34
7400027711	05/18/2023	1297	BOB'S DAIRY SERVICE	10.0.2560.415.00.0000.00	GAL HOMO	\$14.85
Check Total:						\$811.59
NCB	05/10/2023	1282	BP	20.0.2540.464.00.0000.00	GAS FOR THE DIST TRUCK	\$113.80
NCB	05/10/2023	1282	BP	20.0.2540.464.00.0000.00	GAS FOR DIST TRUCK	\$127.42
Check Total:						\$241.22
7400027648	05/04/2023	1273	BRADFORD SYSTEMS CORPORATION	60.0.2530.500.00.0000.00	ALL OF THE FURNITURE LISTED ON BSC	\$29,175.67
Check Total:						\$29,175.67

Lincolnwood School District 74

Disbursement Detail Listing

Bank Name: COLE TAYLOR BANK - ACCOUNTS PAYABLE Date Range: 05/01/2023 - 05/31/2023 Sort By: Vendor
 Voucher Range: - Dollar Limit: \$0.00

Fiscal Year: 2022-2023

Print Employee Vendor Names Exclude Voided Checks Exclude Manual Checks Include Non Check Batches

Check Number	Date	Voucher	Payee	Account	Description	Amount
7400027712	05/18/2023	1297	BRIAN C MAISEL	10.0.1100.338.42.0000.03	SOCCER OFFICIAL/4/21/23	\$63.00
7400027712	05/18/2023	1297	BRIAN C MAISEL	10.0.1100.338.42.0000.03	SOCCER OFFICIAL/5/1/23	\$63.00
7400027712	05/18/2023	1297	BRIAN C MAISEL	10.0.1100.338.42.0000.03	SOCCER OFFICIAL/5/6/23	\$63.00
Check Total:						\$189.00
7400027649	05/04/2023	1273	BUCKEYE CLEANING CENTER-CHICAGO	20.0.2540.416.00.0000.03	Towel HRT white 7,25"x750'	\$1,995.90
7400027649	05/04/2023	1273	BUCKEYE CLEANING CENTER-CHICAGO	20.0.2540.416.00.0000.02	E-14	\$218.50
7400027649	05/04/2023	1273	BUCKEYE CLEANING CENTER-CHICAGO	20.0.2540.416.00.0000.02	Liner 24x32 .7mil Black	\$468.75
7400027649	05/04/2023	1273	BUCKEYE CLEANING CENTER-CHICAGO	20.0.2540.416.00.0000.02	Liner 33x40 .85mil Black	\$285.00
7400027649	05/04/2023	1273	BUCKEYE CLEANING CENTER-CHICAGO	20.0.2540.416.00.0000.02	Liner 38x58 1,9mil Black	\$225.50
7400027649	05/04/2023	1273	BUCKEYE CLEANING CENTER-CHICAGO	20.0.2540.416.00.0000.02	Liner 40x46 1,5mil Blue	\$464.55
7400027649	05/04/2023	1273	BUCKEYE CLEANING CENTER-CHICAGO	20.0.2540.416.00.0000.03	Towel Cntrpull WHT 8"x600'	\$931.65
7400027649	05/04/2023	1273	BUCKEYE CLEANING CENTER-CHICAGO	20.0.2540.416.00.0000.02	E-14	\$109.25
7400027649	05/04/2023	1273	BUCKEYE CLEANING CENTER-CHICAGO	20.0.2540.416.00.0000.02	Liner 38x58 1,9mil Black	\$451.00
7400027649	05/04/2023	1273	BUCKEYE CLEANING CENTER-CHICAGO	20.0.2540.416.00.0000.02	E-14	\$218.50
7400027649	05/04/2023	1273	BUCKEYE CLEANING CENTER-CHICAGO	20.0.2540.416.00.0000.04	Sanicare D.R.C	\$259.60
Check Total:						\$5,628.20
7400027713	05/18/2023	1297	BUCKEYE CLEANING CENTER-CHICAGO	20.0.2540.416.00.0000.04	Sanicare D.R.C	\$46.92
Check Total:						\$46.92
7400027650	05/04/2023	1273	BUSINESS EXPRESS	10.0.1100.449.00.0000.02	PADS OF RUTLEDGE	\$500.00
Check Total:						\$500.00
7400027651	05/04/2023	1273	BUSINESSOLVER.COM	10.0.2520.300.00.0000.00	ANCILLARY PLAN SERVICES PEPM SPNSORED LINES OF	\$26.25
Check Total:						\$26.25

Lincolnwood School District 74

Disbursement Detail Listing

Bank Name: COLE TAYLOR BANK - ACCOUNTS PAYABLE Date Range: 05/01/2023 - 05/31/2023 Sort By: Vendor
 Voucher Range: - Dollar Limit: \$0.00

Fiscal Year: 2022-2023

Print Employee Vendor Names Exclude Voided Checks Exclude Manual Checks Include Non Check Batches

Check Number	Date	Voucher	Payee	Account	Description	Amount
7400027652	05/04/2023	1273	CAROLINA BIOLOGICAL SUPPLY	10.0.1100.410.21.0000.03	Polypropylene Beakers – 250 mL	\$44.02
7400027652	05/04/2023	1273	CAROLINA BIOLOGICAL SUPPLY	10.0.1100.410.21.0000.03	My First Lab® Duo-Scope Microscope	\$335.01
7400027652	05/04/2023	1273	CAROLINA BIOLOGICAL SUPPLY	10.0.1100.410.21.0000.03	Carolina's Perfect Solution® Preserved Frogs, 5"+ (Pail)	\$1,121.01
7400027652	05/04/2023	1273	CAROLINA BIOLOGICAL SUPPLY	10.0.1100.410.21.0000.03	Owl Pellets – Large (Pack of 15)	\$575.01
Check Total:						\$2,075.05
7400027653	05/04/2023	1273	CASSANDRA STRINGS, INC.	10.0.1100.323.31.0000.00	GLUE OPEN SEAMS	\$70.00
7400027653	05/04/2023	1273	CASSANDRA STRINGS, INC.	10.0.1100.323.31.0000.00	\$-10.5 DISC- GLUE OPEN SEAMS	(\$10.50)
Check Total:						\$59.50
7400027654	05/04/2023	1273	CASSIDY GARCIA	10.0.1100.230.00.0000.00	TUITION REIMBURSEMENT	\$675.00
Check Total:						\$675.00
7400027714	05/18/2023	1297	CDI CORP	10.0.1100.411.18.0000.03	B2E-BACKDROP(8X10)	\$900.00
Check Total:						\$900.00
NCB	05/10/2023	1282	CDW GOVERNMENT, INC.	10.0.1100.412.05.0000.00	LABEL PRINTER	\$114.90
Check Total:						\$114.90
7400027655	05/04/2023	1273	CDW GOVERNMENT, INC.	10.0.1100.412.05.0000.00	Logitech MK200 USB Wired Keyboard & Mouse Set	\$584.74
7400027655	05/04/2023	1273	CDW GOVERNMENT, INC.	10.0.1100.700.05.0000.00	Samsung SJ55W Series – LED monitor	\$636.88
7400027655	05/04/2023	1273	CDW GOVERNMENT, INC.	10.0.1100.412.05.0000.00	ViewSonic VA27 STEM Monitor	\$3,473.80
Check Total:						\$4,695.42
7400027715	05/18/2023	1297	CENTRAL RESTAURANT PRODUCTS	10.0.1100.423.36.0000.03	Reynolds 17306240 Heavy Duty Aluminum Foil Roll	\$157.51
7400027715	05/18/2023	1297	CENTRAL RESTAURANT PRODUCTS	10.0.1100.423.36.0000.03	Description Winco MXBH-300 3qt Mixing Bowl,	\$55.06

Lincolnwood School District 74

Disbursement Detail Listing

Bank Name: COLE TAYLOR BANK - ACCOUNTS PAYABLE Date Range: 05/01/2023 - 05/31/2023 Sort By: Vendor
 Voucher Range: - Dollar Limit: \$0.00

Fiscal Year: 2022-2023

Print Employee Vendor Names Exclude Voided Checks Exclude Manual Checks Include Non Check Batches

Check Number	Date	Voucher	Payee	Account	Description	Amount
7400027715	05/18/2023	1297	CENTRAL RESTAURANT PRODUCTS	10.0.1100.423.36.0000.03	Chef's Choice Pronto Diamond Hone Commercial	\$33.40
7400027715	05/18/2023	1297	CENTRAL RESTAURANT PRODUCTS	10.0.1100.423.36.0000.03	Tablecraft 1510 Rubber Blade Spatula, 10"	\$36.26
7400027715	05/18/2023	1297	CENTRAL RESTAURANT PRODUCTS	10.0.1100.423.36.0000.03	OXO 1050030 Measuring Cup - Angled 4 Cup	\$93.00
Check Total:						\$375.23
7400027716	05/18/2023	1297	CHICAGO METROPOLITAN FIRE PREVENTION 2	20.0.2540.320.00.0000.02	ANNUAL SPRINKLER SYSTEM TEST/INSPECTION	\$277.63
7400027716	05/18/2023	1297	CHICAGO METROPOLITAN FIRE PREVENTION 2	20.0.2540.320.00.0000.02	ONLINE REPORTING FEE	\$37.37
7400027716	05/18/2023	1297	CHICAGO METROPOLITAN FIRE PREVENTION 2	20.0.2540.320.00.0000.01	ANNUAL SPRINKLER SYSTEM TEST/INSPECTION	\$220.00
7400027716	05/18/2023	1297	CHICAGO METROPOLITAN FIRE PREVENTION 2	20.0.2540.320.00.0000.01	ONLINE REPORTING FEE	\$35.00
7400027716	05/18/2023	1297	CHICAGO METROPOLITAN FIRE PREVENTION 2	20.0.2540.320.00.0000.03	ANNUAL SPRINKLER SYSTEM TEST/INSPECTION	\$260.00
7400027716	05/18/2023	1297	CHICAGO METROPOLITAN FIRE PREVENTION 2	20.0.2540.320.00.0000.03	ONLINE REPORTING FEE	\$35.00
Check Total:						\$865.00
7400027656	05/04/2023	1273	CMFP DEPT LW-6AC	20.0.2540.320.00.0000.03	QUARTERLY BILLING FB/A RADIO	\$240.00
7400027656	05/04/2023	1273	CMFP DEPT LW-6AC	20.0.2540.320.00.0000.04	QUARTERLY BILLING FB/A RADIO	\$240.00
7400027656	05/04/2023	1273	CMFP DEPT LW-6AC	20.0.2540.320.00.0000.02	QUARTERLY BILLING FB/A RADIO	\$240.00
7400027656	05/04/2023	1273	CMFP DEPT LW-6AC	20.0.2540.320.00.0000.01	QUARTERLY BILLING FB/A RADIO	\$240.00
Check Total:						\$960.00
NCB	05/12/2023	1293	COLE TAYLOR BAN_SIT	10.3.0499.300.00.0000.00	STATE TAX	\$23,021.84
NCB	05/12/2023	1293	COLE TAYLOR BAN_SIT	20.3.0499.300.00.0000.00	STATE TAX	\$806.41
NCB	05/08/2023	1298	COLE TAYLOR BANK	10.3.0499.400.00.0000.00	MUNICIPAL RETIREMENT	\$8,174.22

Lincolnwood School District 74

Disbursement Detail Listing

Bank Name: COLE TAYLOR BANK - ACCOUNTS PAYABLE Date Range: 05/01/2023 - 05/31/2023 Sort By: Vendor
 Voucher Range: - Dollar Limit: \$0.00

Fiscal Year: 2022-2023

Print Employee Vendor Names Exclude Voided Checks Exclude Manual Checks Include Non Check Batches

Check Number	Date	Voucher	Payee	Account	Description	Amount	
NCB	05/08/2023	1298	COLE TAYLOR BANK	20.3.0499.400.00.0000.00	MUNICIPAL RETIREMENT	\$2,328.06	
NCB	05/01/2023	1290	COLE TAYLOR BANK	10.3.0499.100.10.0000.00	TEACHERS PENSION	\$1,006.21	
NCB	05/08/2023	1298	COLE TAYLOR BANK	10.3.0499.400.00.0000.00	MUNICIPAL RETIREMENT	\$839.75	
NCB	05/08/2023	1298	COLE TAYLOR BANK	20.3.0499.400.00.0000.00	MUNICIPAL RETIREMENT	\$431.07	
NCB	05/01/2023	1289	COLE TAYLOR BANK	10.0.1100.801.00.0000.00	THIS	\$17,957.13	
NCB	05/01/2023	1290	COLE TAYLOR BANK	10.3.0499.100.10.0000.00	TEACHERS PENSION ADJ	\$16.11	
NCB	05/08/2023	1298	COLE TAYLOR BANK	10.3.0499.400.00.0000.00	MUNICIPAL RETIREMENT	\$839.75	
NCB	05/08/2023	1298	COLE TAYLOR BANK	20.3.0499.400.00.0000.00	MUNICIPAL RETIREMENT	\$449.86	
NCB	05/01/2023	1290	COLE TAYLOR BANK	10.3.0499.100.10.0000.00	TEACHERS PENSION	\$48,427.87	
NCB	05/08/2023	1298	COLE TAYLOR BANK	10.3.0499.400.00.0000.00	MUNICIPAL RETIREMENT ADJ	(\$4.13)	
NCB	05/08/2023	1298	COLE TAYLOR BANK	10.3.0499.400.00.0000.00	MUNICIPAL RETIREMENT	\$8,408.08	
NCB	05/08/2023	1298	COLE TAYLOR BANK	20.3.0499.400.00.0000.00	MUNICIPAL RETIREMENT	\$2,392.36	
NCB	05/12/2023	1292	COLE TAYLOR BANK_FIT	10.3.0499.700.10.0000.00	SOC.SEC.	\$8,916.28	
NCB	05/12/2023	1292	COLE TAYLOR BANK_FIT	20.3.0499.700.10.0000.00	NON-CAPITAL EQUIPMENT	\$2,368.94	
NCB	05/12/2023	1292	COLE TAYLOR BANK_FIT	10.3.0499.800.20.0000.00	MEDICARE	\$16,001.92	
NCB	05/12/2023	1292	COLE TAYLOR BANK_FIT	20.3.0499.800.20.0000.00	TERMINATION/VACATION PAYMENTS	\$554.00	
NCB	05/12/2023	1292	COLE TAYLOR BANK_FIT	10.3.0499.200.00.0000.00	FEDERAL TAX	\$49,929.73	
NCB	05/12/2023	1292	COLE TAYLOR BANK_FIT	20.3.0499.200.00.0000.00	FEDERAL TAX	\$1,748.02	
						Check Total:	\$194,613.48
7400027657	05/04/2023	1273	COMPASS HEALTH CENTER LLC HC	10.0.1100.123.00.0000.00	HOME HOSPITAL SERVICES FOR STUDENTS	\$632.70	
						Check Total:	\$632.70
7400027658	05/04/2023	1273	CONNIE CHRISTOS	10.0.2210.312.00.0000.03	MILEAGE REIMBURSEMENT/IMPLEMEN	\$41.92	
						Check Total:	\$41.92
7400027659	05/04/2023	1273	CONTOUR LANDSCAPING, INC.	20.0.2540.310.00.0000.00	SPRING TURF REPAIRS WITH SEE, SOIL AND FERTILIZER	\$6,504.00	
7400027659	05/04/2023	1273	CONTOUR LANDSCAPING, INC.	20.0.2540.310.00.0000.00	WEEKLY MAINTENANCE VISIT/3/27 & 3/28/2023	\$1,992.00	
						Check Total:	\$8,496.00

Lincolnwood School District 74

Disbursement Detail Listing

Bank Name: COLE TAYLOR BANK - ACCOUNTS PAYABLE Date Range: 05/01/2023 - 05/31/2023 Sort By: Vendor
 Voucher Range: - Dollar Limit: \$0.00

Fiscal Year: 2022-2023

Print Employee Vendor Names Exclude Voided Checks Exclude Manual Checks Include Non Check Batches

Check Number	Date	Voucher	Payee	Account	Description	Amount	
7400027717	05/18/2023	1297	CONTOUR LANDSCAPING, INC.	20.0.2540.310.00.0000.00	WEEKLY MAINTENANCE	\$996.00	
7400027717	05/18/2023	1297	CONTOUR LANDSCAPING, INC.	20.0.2540.310.00.0000.00	SPRING CLEANING & CUTTING BACK OF RAIN	\$590.00	
						Check Total:	\$1,586.00
7400027660	05/04/2023	1273	COOK COUNTY TREASURER	20.0.2540.320.00.0000.01	MAINTENANCE OF TRAFFIC SIGNALS/FLASHING	\$240.00	
						Check Total:	\$240.00
7400027661	05/04/2023	1273	COURTNEY WHITED	10.0.2520.312.00.0000.00	EXPENSE REIMBURSEMENT/IASBO	\$892.47	
						Check Total:	\$892.47
7400027718	05/18/2023	1297	DANA FREEMAN	10.0.1100.230.00.0000.00	TUITION REIMBURSEMENT	\$1,111.90	
						Check Total:	\$1,111.90
7400027662	05/04/2023	1273	DANIEL GILBERT	10.0.1100.338.42.0000.03	SOCCER OFFICIAL/4/25/23	\$63.00	
						Check Total:	\$63.00
NCB	05/10/2023	1282	DELL INC.	10.0.1100.532.05.0000.00	INSPIRON 27 ALL-IN-ONE	\$2,857.58	
						Check Total:	\$2,857.58
7400027719	05/18/2023	1297	DEPAUL UNIVERSITY	10.0.2630.300.00.0000.00	CAHILL SCHOLARSHIP/PORTER	\$500.00	
						Check Total:	\$500.00
7400027700	05/12/2023	1291	DISTRICT 74	10.3.0499.900.00.0000.00	OTHER PAYROLL LIABILITIES	(\$1.90)	
7400027700	05/12/2023	1291	DISTRICT 74	10.3.0499.900.00.0000.00	OTHER PAYROLL LIABILITIES	\$175.75	
7400027700	05/12/2023	1291	DISTRICT 74	20.3.0499.900.00.0000.00	OTHER PAYROLL LIABILITIES	\$4.75	
7400027700	05/12/2023	1291	DISTRICT 74	10.3.0499.900.00.0000.00	OTHER PAYROLL LIABILITIES	\$11.40	
						Check Total:	\$190.00
NCB	05/10/2023	1282	DOLLAR TREE STORES, INC.	10.0.1100.410.23.0000.03	FISHING GAME SETS WITH FOUR FISH	\$30.00	
NCB	05/10/2023	1282	DOLLAR TREE STORES, INC.	10.0.1100.450.17.0000.03	TEASERS PUZZLE/BEACH	\$352.50	
NCB	05/10/2023	1282	DONE DEAL PROMOTIONS	10.0.1100.449.00.0000.03	LINCOLN HALL SHIRTS	\$673.84	
NCB	05/01/2023	1275	EDUCATIONAL BENEFIT COOPERATIVE	10.3.0499.600.00.0000.00	EMPLOYEE BENEFIT-	\$4,603.28	
NCB	05/01/2023	1275	EDUCATIONAL BENEFIT COOPERATIVE	10.3.0499.600.00.0000.00	EMPLOYEE BENEFIT-	\$1,089.93	

Lincolnwood School District 74

Disbursement Detail Listing

Bank Name: COLE TAYLOR BANK - ACCOUNTS PAYABLE Date Range: 05/01/2023 - 05/31/2023 Sort By: Vendor
 Voucher Range: - Dollar Limit: \$0.00

Fiscal Year: 2022-2023

Print Employee Vendor Names
 Exclude Voided Checks
 Exclude Manual Checks
 Include Non Check Batches

Check Number	Date	Voucher	Payee	Account	Description	Amount
NCB	05/01/2023	1275	EDUCATIONAL BENEFIT COOPERATIVE	10.3.0499.600.00.0000.00	EMPLOYEE BENEFIT-	\$63.00
NCB	05/01/2023	1275	EDUCATIONAL BENEFIT COOPERATIVE	10.3.0499.602.00.0000.00	EMPLOYEE BENEFIT- LIFE	\$257.85
NCB	05/01/2023	1275	EDUCATIONAL BENEFIT COOPERATIVE	10.3.0499.600.00.0000.00	EMPLOYEE BENEFIT-	\$28,378.51
NCB	05/01/2023	1275	EDUCATIONAL BENEFIT COOPERATIVE	20.3.0499.600.00.0000.00	EMPLOYEE BENEFIT-	\$1,979.36
NCB	05/01/2023	1275	EDUCATIONAL BENEFIT COOPERATIVE	10.3.0499.600.00.0000.00	EMPLOYEE BENEFIT-	\$427.74
NCB	05/01/2023	1275	EDUCATIONAL BENEFIT COOPERATIVE	10.3.0499.601.00.0000.00	EMPLOYEE BENEFIT-	\$4,541.66
NCB	05/01/2023	1275	EDUCATIONAL BENEFIT COOPERATIVE	20.3.0499.601.00.0000.00	EMPLOYEE BENEFIT-	\$201.84
NCB	05/01/2023	1275	EDUCATIONAL BENEFIT COOPERATIVE	10.3.0499.600.00.0000.00	EMPLOYEE BENEFIT-	(\$6.27)
NCB	05/01/2023	1275	EDUCATIONAL BENEFIT COOPERATIVE	10.3.0499.602.00.0000.00	EMPLOYEE BENEFIT- LIFE	(\$48.20)
NCB	05/01/2023	1275	EDUCATIONAL BENEFIT COOPERATIVE	10.3.0499.600.00.0000.00	EMPLOYEE BENEFIT-	\$28,378.51
NCB	05/01/2023	1275	EDUCATIONAL BENEFIT COOPERATIVE	20.3.0499.600.00.0000.00	EMPLOYEE BENEFIT-	\$1,979.36
NCB	05/01/2023	1275	EDUCATIONAL BENEFIT COOPERATIVE	10.3.0499.601.00.0000.00	EMPLOYEE BENEFIT-	\$43.27
NCB	05/01/2023	1275	EDUCATIONAL BENEFIT COOPERATIVE	10.3.0499.602.00.0000.00	EMPLOYEE BENEFIT- LIFE	\$302.85
NCB	05/01/2023	1275	EDUCATIONAL BENEFIT COOPERATIVE	10.3.0499.600.00.0000.00	EMPLOYEE BENEFIT-	\$69,399.48
NCB	05/01/2023	1275	EDUCATIONAL BENEFIT COOPERATIVE	20.3.0499.600.00.0000.00	EMPLOYEE BENEFIT-	\$2,358.44
NCB	05/01/2023	1275	EDUCATIONAL BENEFIT COOPERATIVE	10.3.0499.601.00.0000.00	EMPLOYEE BENEFIT-	\$133.14
NCB	05/01/2023	1275	EDUCATIONAL BENEFIT COOPERATIVE	10.3.0499.601.00.0000.00	EMPLOYEE BENEFIT-	\$855.90
NCB	05/01/2023	1275	EDUCATIONAL BENEFIT COOPERATIVE	10.3.0499.600.00.0000.00	EMPLOYEE BENEFIT-	\$428.55
NCB	05/01/2023	1275	EDUCATIONAL BENEFIT COOPERATIVE	20.3.0499.600.00.0000.00	EMPLOYEE BENEFIT-	\$13.15

Lincolnwood School District 74

Disbursement Detail Listing

Bank Name: COLE TAYLOR BANK - ACCOUNTS PAYABLE

Date Range: 05/01/2023 - 05/31/2023

Sort By: Vendor

Fiscal Year: 2022-2023

Voucher Range: -

Dollar Limit: \$0.00

Print Employee Vendor Names

Exclude Voided Checks

Exclude Manual Checks

Include Non Check Batches

Check Number	Date	Voucher	Payee	Account	Description	Amount	
NCB	05/01/2023	1275	EDUCATIONAL BENEFIT COOPERATIVE	10.3.0499.600.00.0000.00	EMPLOYEE BENEFIT-	\$9,449.21	
NCB	05/01/2023	1275	EDUCATIONAL BENEFIT COOPERATIVE	10.3.0499.601.00.0000.00	EMPLOYEE BENEFIT-	\$855.90	
NCB	05/01/2023	1275	EDUCATIONAL BENEFIT COOPERATIVE	10.3.0499.601.00.0000.00	EMPLOYEE BENEFIT-	\$43.27	
NCB	05/01/2023	1275	EDUCATIONAL BENEFIT COOPERATIVE	10.3.0499.600.00.0000.00	EMPLOYEE BENEFIT-	\$12,057.47	
NCB	05/01/2023	1275	EDUCATIONAL BENEFIT COOPERATIVE	10.3.0499.600.00.0000.00	EMPLOYEE BENEFIT-	\$63.00	
NCB	05/01/2023	1275	EDUCATIONAL BENEFIT COOPERATIVE	10.3.0499.600.00.0000.00	EMPLOYEE BENEFIT-	\$4,603.28	
NCB	05/01/2023	1275	EDUCATIONAL BENEFIT COOPERATIVE	10.3.0499.600.00.0000.00	EMPLOYEE BENEFIT-	\$425.92	
NCB	05/01/2023	1275	EDUCATIONAL BENEFIT COOPERATIVE	20.3.0499.600.00.0000.00	EMPLOYEE BENEFIT-	\$13.15	
NCB	05/01/2023	1275	EDUCATIONAL BENEFIT COOPERATIVE	10.3.0499.601.00.0000.00	EMPLOYEE BENEFIT-	\$4,440.72	
NCB	05/01/2023	1275	EDUCATIONAL BENEFIT COOPERATIVE	20.3.0499.601.00.0000.00	EMPLOYEE BENEFIT-	\$201.84	
NCB	05/01/2023	1275	EDUCATIONAL BENEFIT COOPERATIVE	10.3.0499.600.00.0000.00	EMPLOYEE BENEFIT-	\$63.00	
NCB	05/01/2023	1275	EDUCATIONAL BENEFIT COOPERATIVE	10.3.0499.600.00.0000.00	EMPLOYEE BENEFIT-	\$71,942.64	
NCB	05/01/2023	1275	EDUCATIONAL BENEFIT COOPERATIVE	20.3.0499.600.00.0000.00	EMPLOYEE BENEFIT-	\$2,358.44	
NCB	05/01/2023	1275	EDUCATIONAL BENEFIT COOPERATIVE	10.3.0499.601.00.0000.00	EMPLOYEE BENEFIT-	\$792.38	
NCB	05/01/2023	1275	EDUCATIONAL BENEFIT COOPERATIVE	10.3.0499.600.00.0000.00	EMPLOYEE BENEFIT-	\$4,603.28	
						Check Total:	\$258,351.19
7400027720	05/18/2023	1297	ELIZABETH STERBA	10.0.1100.300.78.0000.00	REIMBURSEMENT FOR MUSICAL PURCHASES	\$39.95	
						Check Total:	\$39.95
7400027721	05/18/2023	1297	FIRST STUDENT, INC.	40.0.2550.331.00.0000.00	HOME TO SCHOOL TRANSPORTATION/4/23	\$101,333.57	
7400027721	05/18/2023	1297	FIRST STUDENT, INC.	40.0.2550.330.00.0000.00	LH TO CULVER/4/5/23	\$201.96	

Lincolnwood School District 74

Disbursement Detail Listing

Bank Name: COLE TAYLOR BANK - ACCOUNTS PAYABLE Date Range: 05/01/2023 - 05/31/2023 Sort By: Vendor
 Voucher Range: - Dollar Limit: \$0.00

Fiscal Year: 2022-2023

Print Employee Vendor Names
 Exclude Voided Checks
 Exclude Manual Checks
 Include Non Check Batches

Check Number	Date	Voucher	Payee	Account	Description	Amount
7400027721	05/18/2023	1297	FIRST STUDENT, INC.	40.0.2550.330.00.0000.00	LH TO HOLOCAUST MUSEUM/4/7/23	\$254.84
7400027721	05/18/2023	1297	FIRST STUDENT, INC.	40.0.2550.330.00.0000.00	LH TO HOLOCAUST MUSEUM/4/7/23	\$275.86
7400027721	05/18/2023	1297	FIRST STUDENT, INC.	40.0.2550.330.00.0000.00	LH TO HOLOCAUST MUSEUM/4/7/23	\$226.17
7400027721	05/18/2023	1297	FIRST STUDENT, INC.	40.0.2550.330.00.0000.00	LH TO HOLOCAUST MUSEUM 4/7/23	\$223.62
7400027721	05/18/2023	1297	FIRST STUDENT, INC.	40.0.2550.330.00.0000.00	LH TO MCCRACKEN	\$127.42
7400027721	05/18/2023	1297	FIRST STUDENT, INC.	40.0.2550.330.00.0000.00	LH TO	\$162.46
7400027721	05/18/2023	1297	FIRST STUDENT, INC.	40.0.2550.330.00.0000.00	LH TO FAIRVIEW/4/12/23	\$148.44
7400027721	05/18/2023	1297	FIRST STUDENT, INC.	40.0.2550.330.00.0000.00	LH TO GOLF	\$160.54
7400027721	05/18/2023	1297	FIRST STUDENT, INC.	40.0.2550.330.00.0000.00	LH TO LINCOLN JR HIGH 4/13/23	\$100.66
7400027721	05/18/2023	1297	FIRST STUDENT, INC.	40.0.2550.330.00.0000.00	LH TO NILES WEST/4/13/23	\$158.00
7400027721	05/18/2023	1297	FIRST STUDENT, INC.	40.0.2550.330.00.0000.00	LH TO LINCOLN JR HIGH/4/14/23	\$135.06
7400027721	05/18/2023	1297	FIRST STUDENT, INC.	40.0.2550.330.00.0000.00	LH TO FAIRVIEW/4/19/23	\$138.25
7400027721	05/18/2023	1297	FIRST STUDENT, INC.	40.0.2550.330.00.0000.00	LH TO EAST PRAIRIE/4/19/23	\$149.71
7400027721	05/18/2023	1297	FIRST STUDENT, INC.	40.0.2550.330.00.0000.00	LH TO	\$138.25
7400027721	05/18/2023	1297	FIRST STUDENT, INC.	40.0.2550.330.00.0000.00	LH TO KOHL CHILDREN MUSEUM	\$228.08
7400027721	05/18/2023	1297	FIRST STUDENT, INC.	40.0.2550.330.00.0000.00	LH TO KOHL CHILDREN MUSEUM/4/19/23	\$217.89
7400027721	05/18/2023	1297	FIRST STUDENT, INC.	40.0.2550.330.00.0000.00	LH TO LINCOLN JR HIGH/4/24/23	\$217.89
7400027721	05/18/2023	1297	FIRST STUDENT, INC.	40.0.2550.330.00.0000.00	LH TO GOLF MIDDLE SCHOOL/4/24/23	\$140.16

Lincolnwood School District 74

Disbursement Detail Listing

Bank Name: COLE TAYLOR BANK - ACCOUNTS PAYABLE Date Range: 05/01/2023 - 05/31/2023 Sort By: Vendor
 Voucher Range: - Dollar Limit: \$0.00

Fiscal Year: 2022-2023

Print Employee Vendor Names Exclude Voided Checks Exclude Manual Checks Include Non Check Batches

Check Number	Date	Voucher	Payee	Account	Description	Amount
7400027721	05/18/2023	1297	FIRST STUDENT, INC.	40.0.2550.330.00.0000.00	TH TO NORTH PARK NATURE CENTER/4/27/23	\$98.75
7400027721	05/18/2023	1297	FIRST STUDENT, INC.	40.0.2550.330.00.0000.00	RH TO	\$348.49
7400027721	05/18/2023	1297	FIRST STUDENT, INC.	40.0.2550.330.00.0000.00	RH TO	\$350.41
7400027721	05/18/2023	1297	FIRST STUDENT, INC.	40.0.2550.330.00.0000.00	RH TO	\$382.26
7400027721	05/18/2023	1297	FIRST STUDENT, INC.	40.0.2550.330.00.0000.00	TH TO NORTH PARK NATURE CENTER/4/27/23	\$98.75
7400027721	05/18/2023	1297	FIRST STUDENT, INC.	40.0.2550.330.00.0000.00	RH TO	\$350.41
Check Total:						\$106,367.90
7400027663	05/04/2023	1273	FOLLETT CONTENT SOLUTIONS, LLC	10.0.2220.400.00.0000.02	BOOKS/GRIMMS MANGA TALES/KILALA PRINCESS	\$57.64
Check Total:						\$57.64
7400027664	05/04/2023	1273	FOLLETT CONTENT SOLUTIONS, LLC.-2	10.0.2220.400.00.0000.01	All You Need Is Mud (#2633SA6)	\$14.57
7400027664	05/04/2023	1273	FOLLETT CONTENT SOLUTIONS, LLC.-2	10.0.2220.400.00.0000.01	Good luck, Anna Hibiscus! (part of set #A565640)	\$15.36
7400027664	05/04/2023	1273	FOLLETT CONTENT SOLUTIONS, LLC.-2	10.0.2220.400.00.0000.01	Berry song (#2700PB1)	\$22.16
7400027664	05/04/2023	1273	FOLLETT CONTENT SOLUTIONS, LLC.-2	10.0.2220.400.00.0000.01	Big truck little island (#1754HU8)	\$16.74
7400027664	05/04/2023	1273	FOLLETT CONTENT SOLUTIONS, LLC.-2	10.0.2220.400.00.0000.01	Bulldogs (#1589RV8)	\$21.04
7400027664	05/04/2023	1273	FOLLETT CONTENT SOLUTIONS, LLC.-2	10.0.2220.400.00.0000.01	The Case of the Musical Mishap (#2581WA5)	\$14.01
7400027664	05/04/2023	1273	FOLLETT CONTENT SOLUTIONS, LLC.-2	10.0.2220.400.00.0000.01	Chloe's Lunar New Year (#2667KAX)	\$17.53
7400027664	05/04/2023	1273	FOLLETT CONTENT SOLUTIONS, LLC.-2	10.0.2220.400.00.0000.01	Dear teacher, : a celebration of people who inspire us	\$17.53
7400027664	05/04/2023	1273	FOLLETT CONTENT SOLUTIONS, LLC.-2	10.0.2220.400.00.0000.01	Dim sum, here we come! (#2667MA4)	\$17.53

Lincolnwood School District 74

Disbursement Detail Listing

Bank Name: COLE TAYLOR BANK - ACCOUNTS PAYABLE

Date Range: 05/01/2023 - 05/31/2023

Sort By: Vendor

Fiscal Year: 2022-2023

Voucher Range: -

Dollar Limit: \$0.00

Print Employee Vendor Names

Exclude Voided Checks

Exclude Manual Checks

Include Non Check Batches

Check Number	Date	Voucher	Payee	Account	Description	Amount
7400027664	05/04/2023	1273	FOLLETT CONTENT SOLUTIONS, LLC.-2	10.0.2220.400.00.0000.01	Every dog in the neighborhood (#1774VZ1)	\$17.53
7400027664	05/04/2023	1273	FOLLETT CONTENT SOLUTIONS, LLC.-2	10.0.2220.400.00.0000.01	Home is where the heart is (#1840MQ5)	\$13.77
7400027664	05/04/2023	1273	FOLLETT CONTENT SOLUTIONS, LLC.-2	10.0.2220.400.00.0000.01	Hot dog (#2701DB0)	\$22.16
7400027664	05/04/2023	1273	FOLLETT CONTENT SOLUTIONS, LLC.-2	10.0.2220.400.00.0000.01	I did it! (#2700WB2)	\$19.36
7400027664	05/04/2023	1273	FOLLETT CONTENT SOLUTIONS, LLC.-2	10.0.2220.400.00.0000.01	I'm not scared, you're scared! (#1891MW8)	\$17.62
7400027664	05/04/2023	1273	FOLLETT CONTENT SOLUTIONS, LLC.-2	10.0.2220.400.00.0000.01	Kick push (#1899PT6)	\$17.62
7400027664	05/04/2023	1273	FOLLETT CONTENT SOLUTIONS, LLC.-2	10.0.2220.400.00.0000.01	Knight Owl (#2700LB2)	\$21.46
7400027664	05/04/2023	1273	FOLLETT CONTENT SOLUTIONS, LLC.-2	10.0.2220.400.00.0000.01	Lift, mix, fling! : machines can do anything	\$16.74
7400027664	05/04/2023	1273	FOLLETT CONTENT SOLUTIONS, LLC.-2	10.0.2220.400.00.0000.01	Magnolia Flower (#1747YZ6)	\$18.50
7400027664	05/04/2023	1273	FOLLETT CONTENT SOLUTIONS, LLC.-2	10.0.2220.400.00.0000.01	Moon's Ramadan	\$17.53
7400027664	05/04/2023	1273	FOLLETT CONTENT SOLUTIONS, LLC.-2	10.0.2220.400.00.0000.01	The Night Before Eid A Muslim Family Story	\$17.53
7400027664	05/04/2023	1273	FOLLETT CONTENT SOLUTIONS, LLC.-2	10.0.2220.400.00.0000.01	Olivia wrapped in vines (#1709VV2)	\$18.47
7400027664	05/04/2023	1273	FOLLETT CONTENT SOLUTIONS, LLC.-2	10.0.2220.400.00.0000.01	Patchwork (#1890KY3)	\$17.62
7400027664	05/04/2023	1273	FOLLETT CONTENT SOLUTIONS, LLC.-2	10.0.2220.400.00.0000.01	Pick a perfect egg (#1976VX7)	\$16.65
7400027664	05/04/2023	1273	FOLLETT CONTENT SOLUTIONS, LLC.-2	10.0.2220.400.00.0000.01	Tiny dino (#1915QU7)	\$16.74
7400027664	05/04/2023	1273	FOLLETT CONTENT SOLUTIONS, LLC.-2	10.0.2220.400.00.0000.01	Where butterflies fill the sky : a story of immigration,	\$17.62

Lincolnwood School District 74

Disbursement Detail Listing

Bank Name: COLE TAYLOR BANK - ACCOUNTS PAYABLE

Date Range: 05/01/2023 - 05/31/2023

Sort By: Vendor

Fiscal Year: 2022-2023

Voucher Range: -

Dollar Limit: \$0.00

Print Employee Vendor Names

Exclude Voided Checks

Exclude Manual Checks

Include Non Check Batches

Check Number	Date	Voucher	Payee	Account	Description	Amount
7400027664	05/04/2023	1273	FOLLETT CONTENT SOLUTIONS, LLC.-2	10.0.2220.400.00.0000.01	Book Cataloging and Processing	\$20.75
Check Total:						\$464.14
7400027722	05/18/2023	1297	FOLLETT CONTENT SOLUTIONS, LLC.-2	10.0.2220.400.00.0000.01	Love from the crayons (#1223DWX)	\$9.70
7400027722	05/18/2023	1297	FOLLETT CONTENT SOLUTIONS, LLC.-2	10.0.2220.400.00.0000.01	Luminous : living things that light up the night	\$17.59
7400027722	05/18/2023	1297	FOLLETT CONTENT SOLUTIONS, LLC.-2	10.0.2220.400.00.0000.01	Book Cataloging and Processing	\$1.66
7400027722	05/18/2023	1297	FOLLETT CONTENT SOLUTIONS, LLC.-2	10.0.2220.400.00.0000.02	Anne of West Philly : a modern graphic retelling of	\$18.36
7400027722	05/18/2023	1297	FOLLETT CONTENT SOLUTIONS, LLC.-2	10.0.2220.400.00.0000.02	Baby-sitters little sister. 6,Karen's birthday	\$38.92
7400027722	05/18/2023	1297	FOLLETT CONTENT SOLUTIONS, LLC.-2	10.0.2220.400.00.0000.02	Berry song (#1611BW5)	\$17.62
7400027722	05/18/2023	1297	FOLLETT CONTENT SOLUTIONS, LLC.-2	10.0.2220.400.00.0000.02	Big shot (#1768PT9)	\$58.08
7400027722	05/18/2023	1297	FOLLETT CONTENT SOLUTIONS, LLC.-2	10.0.2220.400.00.0000.02	The bookstore valentine (#38978V3)	\$12.98
7400027722	05/18/2023	1297	FOLLETT CONTENT SOLUTIONS, LLC.-2	10.0.2220.400.00.0000.02	But excuse me that is my book (#27078V6)	\$21.46
7400027722	05/18/2023	1297	FOLLETT CONTENT SOLUTIONS, LLC.-2	10.0.2220.400.00.0000.02	The castle of tangled magic (#1619YU7)	\$16.74
7400027722	05/18/2023	1297	FOLLETT CONTENT SOLUTIONS, LLC.-2	10.0.2220.400.00.0000.02	The Charlie Thorne collection [3-item set]	\$48.42
7400027722	05/18/2023	1297	FOLLETT CONTENT SOLUTIONS, LLC.-2	10.0.2220.400.00.0000.02	A chocolate moose for dinner (#31367W3)	\$16.26
7400027722	05/18/2023	1297	FOLLETT CONTENT SOLUTIONS, LLC.-2	10.0.2220.400.00.0000.02	Diper overlode (#2487GA2)	\$19.36
7400027722	05/18/2023	1297	FOLLETT CONTENT SOLUTIONS, LLC.-2	10.0.2220.400.00.0000.02	Don't worry, Murray (#1772SX0)	\$16.74

Lincolnwood School District 74

Disbursement Detail Listing

Bank Name: COLE TAYLOR BANK - ACCOUNTS PAYABLE

Date Range: 05/01/2023 - 05/31/2023

Sort By: Vendor

Fiscal Year: 2022-2023

Voucher Range: -

Dollar Limit: \$0.00

Print Employee Vendor Names

Exclude Voided Checks

Exclude Manual Checks

Include Non Check Batches

Check Number	Date	Voucher	Payee	Account	Description	Amount	
7400027722	05/18/2023	1297	FOLLETT CONTENT SOLUTIONS, LLC.-2	10.0.2220.400.00.0000.02	Ellen outside the lines (#1610GW5)	\$15.86	
7400027722	05/18/2023	1297	FOLLETT CONTENT SOLUTIONS, LLC.-2	10.0.2220.400.00.0000.02	Fall down seven times, stand up eight : Patsy	\$16.74	
7400027722	05/18/2023	1297	FOLLETT CONTENT SOLUTIONS, LLC.-2	10.0.2220.400.00.0000.02	Gregor and the curse of the warmbloods (#37609W3)	\$15.88	
7400027722	05/18/2023	1297	FOLLETT CONTENT SOLUTIONS, LLC.-2	10.0.2220.400.00.0000.02	Gregor and the Prophecy of Bane (#1914PC6)	\$15.88	
7400027722	05/18/2023	1297	FOLLETT CONTENT SOLUTIONS, LLC.-2	10.0.2220.400.00.0000.02	Hair love (#1620RH8)	\$21.46	
7400027722	05/18/2023	1297	FOLLETT CONTENT SOLUTIONS, LLC.-2	10.0.2220.400.00.0000.02	I am golden (#1900GT9)	\$17.62	
7400027722	05/18/2023	1297	FOLLETT CONTENT SOLUTIONS, LLC.-2	10.0.2220.400.00.0000.02	Red and green and blue and white (#1939TR0)	\$16.74	
7400027722	05/18/2023	1297	FOLLETT CONTENT SOLUTIONS, LLC.-2	10.0.2220.400.00.0000.02	The school for whatnots (#1896ZU8)	\$17.99	
7400027722	05/18/2023	1297	FOLLETT CONTENT SOLUTIONS, LLC.-2	10.0.2220.400.00.0000.02	Sitting shiva (#1858SX2)	\$20.23	
7400027722	05/18/2023	1297	FOLLETT CONTENT SOLUTIONS, LLC.-2	10.0.2220.400.00.0000.02	Snowy Valentine (#0053HR1)	\$14.10	
7400027722	05/18/2023	1297	FOLLETT CONTENT SOLUTIONS, LLC.-2	10.0.2220.400.00.0000.02	Something wicked (#1779QX0)	\$15.77	
7400027722	05/18/2023	1297	FOLLETT CONTENT SOLUTIONS, LLC.-2	10.0.2220.400.00.0000.02	Book Cataloging and Processing	\$25.92	
						Check Total:	\$528.08
7400027723	05/18/2023	1297	FRONTLINE TECHNOLOGIES GROUP, LLC	10.0.1100.470.05.0000.00	APPLICANT TRACKING, UNLIMITED USAGE FOR	\$1,782.21	
						Check Total:	\$1,782.21
NCB	05/10/2023	1282	GENUITY	10.0.1100.470.05.0000.00	GENUITY/DISTRICT	\$329.89	
						Check Total:	\$329.89
7400027666	05/04/2023	1273	GET FRESH PRODUCE, INC.	10.0.2560.410.00.0000.00	FLORETS BROCCOLI/CABBAGE/CARR	\$423.16	

Lincolnwood School District 74

Disbursement Detail Listing

Bank Name: COLE TAYLOR BANK - ACCOUNTS PAYABLE Date Range: 05/01/2023 - 05/31/2023 Sort By: Vendor
 Voucher Range: - Dollar Limit: \$0.00

Fiscal Year: 2022-2023

Print Employee Vendor Names Exclude Voided Checks Exclude Manual Checks Include Non Check Batches

Check Number	Date	Voucher	Payee	Account	Description	Amount
7400027666	05/04/2023	1273	GET FRESH PRODUCE, INC.	10.0.2560.400.00.0000.00	PLASTIC CUTLERY KIT	\$59.22
7400027666	05/04/2023	1273	GET FRESH PRODUCE, INC.	10.0.2560.410.00.0000.00	PEPPERS/CELERY/CUCUMBE	\$328.81
7400027666	05/04/2023	1273	GET FRESH PRODUCE, INC.	10.0.2560.410.00.0000.00	BROCCOLI	\$461.20
					FLORETS/CAULILOWER	
7400027666	05/04/2023	1273	GET FRESH PRODUCE, INC.	10.0.2560.400.00.0000.00	PLASTIC CUTLERY KIT	\$71.63
7400027666	05/04/2023	1273	GET FRESH PRODUCE, INC.	10.0.2560.410.00.0000.00	CARROTS/CELERY /PEPPERS	\$362.21
					Check Total:	\$1,706.23
7400027724	05/18/2023	1297	GET FRESH PRODUCE, INC.	10.0.2560.410.00.0000.00	BROCCOLI	\$470.25
					FLORETS/CARROTS/CAULIFL	
7400027724	05/18/2023	1297	GET FRESH PRODUCE, INC.	10.0.2560.400.00.0000.00	PLASTIC CUTLERY KIT	\$59.22
7400027724	05/18/2023	1297	GET FRESH PRODUCE, INC.	10.0.2560.410.00.0000.00	BROCCOLI	\$413.37
					FLORETS/CARROTS/CAULIFL	
7400027724	05/18/2023	1297	GET FRESH PRODUCE, INC.	10.0.2560.400.00.0000.00	PLASTIC CUTLERY KIT	\$98.55
7400027724	05/18/2023	1297	GET FRESH PRODUCE, INC.	10.0.2560.410.00.0000.00	SUGAR SNAP PEAS/BERRIES	\$215.55
7400027724	05/18/2023	1297	GET FRESH PRODUCE, INC.	10.0.2560.410.00.0000.00	FLORETS	\$347.40
7400027724	05/18/2023	1297	GET FRESH PRODUCE, INC.	10.0.2560.410.00.0000.00	CARROTS/CAULIFLOWER/CE LERY	\$417.71
7400027724	05/18/2023	1297	GET FRESH PRODUCE, INC.	10.0.2560.410.00.0000.00	CARROTS	\$14.98
7400027724	05/18/2023	1297	GET FRESH PRODUCE, INC.	10.0.2560.410.00.0000.00	FLORETS	\$336.95
					BROCCOLI/HONEY/CABBAG	
7400027724	05/18/2023	1297	GET FRESH PRODUCE, INC.	10.0.2560.400.00.0000.00	PLASTIC CUTLERY KIT	\$59.13
7400027724	05/18/2023	1297	GET FRESH PRODUCE, INC.	10.0.2560.410.00.0000.00	GRAPE TOMATOES	(\$13.96)
					Check Total:	\$2,419.15
NCB	05/10/2023	1282	GOLF MILL MOTOR SALES, INC.	20.0.2540.700.00.0000.00	DIST TRUCK SERVICE	\$75.98
NCB	05/10/2023	1282	GOODWILL	10.0.1100.300.78.0000.00	MUSICAL ITEMS	\$40.90
					Check Total:	\$116.88
7400027725	05/18/2023	1297	GOPHER SPORT	10.0.1100.502.26.0000.03	UltraFit TyroBALL Rubber Kettlebell Sets	\$1,264.48
					Check Total:	\$1,264.48
7400027667	05/04/2023	1273	GORDON FOOD SERVICE	10.0.2560.400.00.0000.00	FOIL CUTTER/RUBBER GLOVE/CUP	\$165.77

Lincolnwood School District 74

Disbursement Detail Listing

Bank Name: COLE TAYLOR BANK - ACCOUNTS PAYABLE Date Range: 05/01/2023 - 05/31/2023 Sort By: Vendor
 Voucher Range: - Dollar Limit: \$0.00

Fiscal Year: 2022-2023

Print Employee Vendor Names
 Exclude Voided Checks
 Exclude Manual Checks
 Include Non Check Batches

Check Number	Date	Voucher	Payee	Account	Description	Amount
7400027667	05/04/2023	1273	GORDON FOOD SERVICE	10.0.2560.410.00.0000.00	CREAM CHEESE/BAGEL/HOT DOG BUNS	\$1,105.47
7400027667	05/04/2023	1273	GORDON FOOD SERVICE	10.0.1100.449.00.0000.03	BAGELS/BANANAS/CREAM CHEESE	\$395.70
7400027667	05/04/2023	1273	GORDON FOOD SERVICE	10.0.2560.410.00.0000.00	FLOUR TORTL/TOMATOES	\$969.63
7400027667	05/04/2023	1273	GORDON FOOD SERVICE	10.0.2560.400.00.0000.00	TRAY/CUTLERY KIT/GLOVE	\$293.60
7400027667	05/04/2023	1273	GORDON FOOD SERVICE	10.0.2560.410.00.0000.00	FRIED RICE/CREAM CHEESE/BAGEL	\$773.29
7400027667	05/04/2023	1273	GORDON FOOD SERVICE	10.0.2560.410.00.0000.00	TORTILLA FLOUR/FRIED	\$1,004.58
7400027667	05/04/2023	1273	GORDON FOOD SERVICE	10.0.2560.410.00.0000.00	TOMATO PASTE	\$19.98
7400027667	05/04/2023	1273	GORDON FOOD SERVICE	10.0.2560.400.00.0000.00	NAPKIN/CUP PRTN SOUFF	\$29.35
Check Total:						\$4,757.37
7400027726	05/18/2023	1297	GORDON FOOD SERVICE	10.0.2560.410.00.0000.00	CHEESE/BAGEL/GRAPES/SYR	\$1,393.91
7400027726	05/18/2023	1297	GORDON FOOD SERVICE	10.0.2560.400.00.0000.00	TRAY/CONT PLAS/CUP PRTN SOUFF	\$177.24
7400027726	05/18/2023	1297	GORDON FOOD SERVICE	10.0.2560.400.00.0000.00	TRAY/GLOVE/CONT PPR SOUP CUP	\$312.50
7400027726	05/18/2023	1297	GORDON FOOD SERVICE	10.0.2560.410.00.0000.00	STRING CHEESE/BAGEL/FLATBREAD	\$923.97
7400027726	05/18/2023	1297	GORDON FOOD SERVICE	10.0.2560.410.00.0000.00	CREAM CHEESE/FRIED RICE/BAGEL	\$1,513.71
7400027726	05/18/2023	1297	GORDON FOOD SERVICE	10.0.2560.400.00.0000.00	TRAY/LINER BAKE PAN/CONT PLAS	\$193.42
7400027726	05/18/2023	1297	GORDON FOOD SERVICE	10.0.2560.410.00.0000.00	DRESSING/AMER CHEESE/GREEN BEAN	\$1,553.77
7400027726	05/18/2023	1297	GORDON FOOD SERVICE	10.0.2560.400.00.0000.00	GLOVES/KNIFE/CONT PLAS	\$141.89
7400027726	05/18/2023	1297	GORDON FOOD SERVICE	10.0.2560.410.00.0000.00	SYRUP/CHEESE/WAFF	\$102.36
7400027726	05/18/2023	1297	GORDON FOOD SERVICE	10.0.2560.400.00.0000.00	SOAP/CUP PRTN SOUFF/FILM CUTTER	\$32.66
7400027726	05/18/2023	1297	GORDON FOOD SERVICE	10.0.2560.410.00.0000.00	TERIYAKI SAUCE	\$12.99

Lincolnwood School District 74

Disbursement Detail Listing

Bank Name: COLE TAYLOR BANK - ACCOUNTS PAYABLE Date Range: 05/01/2023 - 05/31/2023 Sort By: Vendor
 Voucher Range: - Dollar Limit: \$0.00

Fiscal Year: 2022-2023

Print Employee Vendor Names Exclude Voided Checks Exclude Manual Checks Include Non Check Batches

Check Number	Date	Voucher	Payee	Account	Description	Amount	
7400027726	05/18/2023	1297	GORDON FOOD SERVICE	10.0.2560.400.00.0000.00	CUTLERY KIT	\$120.78	
7400027726	05/18/2023	1297	GORDON FOOD SERVICE	10.0.2560.400.00.0000.00	FLAT LID	\$48.93	
						Check Total:	\$6,528.13
7400027727	05/18/2023	1297	GRAINGER	20.0.2540.400.00.0000.03	KEYED PADLOCK	\$200.58	
						Check Total:	\$200.58
7400027728	05/18/2023	1297	GSF USA, INC.	20.0.2540.322.00.0000.00	JANITORIAL SERVICES/MAY	\$37,483.23	
						Check Total:	\$37,483.23
7400027668	05/04/2023	1273	HAYLEY REYNOLDS	10.0.1100.230.00.0000.00	TUITION REIMBURSEMENT	\$1,021.50	
						Check Total:	\$1,021.50
7400027669	05/04/2023	1273	HEARTLAND BUSINESS SYSTEMS	10.0.1100.310.05.0000.00	MITEL COLLABORATION 11 REGULAR	\$160.00	
						Check Total:	\$160.00
NCB	05/10/2023	1282	HIGH TOUCH-HIGH TECH	10.0.1100.314.04.0000.01	1ST GRADE HHTH STEAM WORKSHOPS	\$50.00	
						Check Total:	\$50.00
7400027729	05/18/2023	1297	HMA DESIGN + PRINT INC.	10.0.1100.300.78.0000.00	BOOKLET/MAGAZINE	\$923.54	
						Check Total:	\$923.54
NCB	05/10/2023	1282	HOBBY LOBBY	10.0.1100.300.78.0000.00	MUSICAL ITEMS	\$31.04	
						Check Total:	\$31.04
7400027670	05/04/2023	1273	IGS ENERGY	20.0.2540.465.00.0000.00	NATURAL GAS	\$9,435.65	
						Check Total:	\$9,435.65
NCB	05/10/2023	1282	ILLINOIS ASSOCIATION OF SCHOOL BOARDS	10.0.2310.340.00.0000.00	BOE MANDATED	\$125.00	
						Check Total:	\$125.00
7400027730	05/18/2023	1297	ILLINOIS ASSOCIATION OF SCHOOL BOARDS	10.0.2310.640.00.0000.00	ANNUAL DUES	\$6,203.00	
						Check Total:	\$6,203.00
NCB	05/10/2023	1282	ILLINOIS PRINCIPALS ASSOCIATION	10.0.2410.312.00.0000.03	2023 THE ASSISTANT PRINCIPALSHIP	\$199.00	
NCB	05/10/2023	1282	ILLINOIS PRINCIPALS ASSOCIATION	10.0.2410.312.00.0000.03	2023 TRAUMA RESPONSIVE PRACTICES	\$299.00	
NCB	05/10/2023	1282	INTERIORS FOR BUSINESS, INC.	10.0.2520.741.00.0000.00	DESK CHAIR	\$483.30	
NCB	05/10/2023	1282	INTERIORS FOR BUSINESS, INC.	10.0.2410.500.00.0000.02	AMPLIFY TASK CHAIR	\$513.54	

Lincolnwood School District 74

Disbursement Detail Listing

Bank Name: COLE TAYLOR BANK - ACCOUNTS PAYABLE Date Range: 05/01/2023 - 05/31/2023 Sort By: Vendor
 Voucher Range: - Dollar Limit: \$0.00

Fiscal Year: 2022-2023

Print Employee Vendor Names
 Exclude Voided Checks
 Exclude Manual Checks
 Include Non Check Batches

Check Number	Date	Voucher	Payee	Account	Description	Amount
NCB	05/10/2023	1282	INTERIORS FOR BUSINESS, INC.	10.0.2520.500.00.0000.00	AMPLIFY TASK CHAIR	\$513.54
NCB	05/10/2023	1282	JEWEL-OSCO	10.0.1100.450.17.0000.03	SOUR PATCH/PLSBRY FUNFETTI	\$28.99
NCB	05/10/2023	1282	JO-ANN	10.0.1100.300.78.0000.00	MUSICAL ITEMS	\$268.06
NCB	05/10/2023	1282	KOHL CHILDREN'S MUSEUM OF GREATER CHGO	10.0.1100.314.04.0000.01	KINDERGARTEN FIELD TRIP	\$624.00
NCB	05/10/2023	1282	KOHL CHILDREN'S MUSEUM OF GREATER CHGO	10.0.1100.314.04.0000.01	KINDERGARTEN FIELD TRIP	\$637.00
Check Total:						\$3,566.43
7400027671	05/04/2023	1273	KRISTIN HAYES	10.0.2130.640.00.0000.03	VISION AND HEARING RECERTIFICATION	\$64.78
Check Total:						\$64.78
7400027731	05/18/2023	1297	LAKESHORE	10.0.1100.400.10.0000.01	SUPPLIES - KINDERGARTEN TEAM	\$57.48
Check Total:						\$57.48
7400027672	05/04/2023	1273	LAKESHORE LEARNING STORE	10.0.1100.700.00.0000.01	Sage Green Calming Colors® Premium Teardrop Beanbag	\$129.00
7400027672	05/04/2023	1273	LAKESHORE LEARNING STORE	10.0.1100.700.00.0000.01	Green Premium Bean Bag	\$99.50
7400027672	05/04/2023	1273	LAKESHORE LEARNING STORE	10.0.1100.700.00.0000.01	Blue Premium Bean Bag	\$99.50
Check Total:						\$328.00
NCB	05/12/2023	1295	LINCOLN INVESTMENT PLANNING	10.3.0499.500.00.0000.00	ANNUITIES PAYABLE	\$250.00
NCB	05/12/2023	1295	LINCOLN INVESTMENT PLANNING	10.3.0499.500.00.0000.00	ANNUITIES PAYABLE	\$1,091.12
NCB	05/12/2023	1295	LINCOLN INVESTMENT PLANNING	10.3.0499.500.00.0000.00	ANNUITIES PAYABLE	\$3,558.33
NCB	05/12/2023	1295	LINCOLN INVESTMENT PLANNING	20.3.0499.500.00.0000.00	ANNUITIES PAYABLE	\$700.00
NCB	05/10/2023	1282	LINCOLNWOOD CHAMBER OF COMMERCE	10.0.2310.312.00.0000.00	REGISTRATION FOR STATE OF THE VILLAGE LUNCHEON	\$180.00
Check Total:						\$5,779.45
7400027732	05/18/2023	1297	Employee Vendor	10.0.1100.338.42.0000.03	VOLLEYBALL OFFICIAL/BOUS VARSITY & JV	\$112.00
Check Total:						\$112.00

Lincolnwood School District 74

Disbursement Detail Listing

Bank Name: COLE TAYLOR BANK - ACCOUNTS PAYABLE

Date Range: 05/01/2023 - 05/31/2023

Sort By: Vendor

Fiscal Year: 2022-2023

Voucher Range: -

Dollar Limit: \$0.00

Print Employee Vendor Names

Exclude Voided Checks

Exclude Manual Checks

Include Non Check Batches

Check Number	Date	Voucher	Payee	Account	Description	Amount	
7400027673	05/04/2023	1273	LITTLE TOMMY'S PLUMBING SHOP	20.0.2540.320.00.0000.03	MAINTENANCE/MAIN LINE CLEAN OUT TO 135 FEET	\$1,333.00	
						Check Total:	\$1,333.00
7400027733	05/18/2023	1297	LITTLE TOMMY'S PLUMBING SHOP	20.0.2540.320.00.0000.03	MAINTENANCE	\$3,773.00	
7400027733	05/18/2023	1297	LITTLE TOMMY'S PLUMBING SHOP	20.0.2540.320.00.0000.03	MAINTENANCE	\$4,704.00	
						Check Total:	\$8,477.00
NCB	05/10/2023	1282	LOU MALNATI'S PIZZERIA	10.0.2310.315.00.0000.00	PIZZA/BOE CONFERENCE DINNER	\$386.62	
NCB	05/10/2023	1282	LOU MALNATI'S PIZZERIA	10.0.2310.315.00.0000.00	PIZZA/BOE CONFERENCE DINNER	\$365.83	
NCB	05/10/2023	1282	LOU MALNATI'S PIZZERIA	10.0.2310.315.00.0000.00	PIZZA/BOE CONFERENCE DINNER	\$386.62	
NCB	05/10/2023	1282	LOWE'S HOME CENTERS, INC.	20.0.2540.400.00.0000.01	MAINTENANCE SUPPLIES	\$251.23	
NCB	05/10/2023	1282	LOWE'S HOME CENTERS, INC.	20.0.2540.400.00.0000.01	MAINTENANCE SUPPLIES	\$160.86	
NCB	05/10/2023	1282	LOWE'S HOME CENTERS, INC.	20.0.2540.400.00.0000.02	PAINT SUPPLIES	\$302.30	
NCB	05/10/2023	1282	LOWE'S HOME CENTERS, INC.	20.0.2540.542.00.0000.00	FLEX 24V 6-TOOL COMBO	\$649.00	
NCB	05/10/2023	1282	LOWE'S HOME CENTERS, INC.	20.0.2540.542.00.0000.00	DISCOUNT COUPON TOOLS	(\$150.00)	
NCB	05/10/2023	1282	LOWE'S HOME CENTERS, INC.	20.0.2540.400.00.0000.02	RETURNED PLUMBING	(\$13.96)	
NCB	05/10/2023	1282	LOWE'S HOME CENTERS, INC.	20.0.2540.400.00.0000.02	PLUMBING PARTS	\$17.96	
NCB	05/10/2023	1282	LOWE'S HOME CENTERS, INC.	20.0.2540.400.00.0000.02	BOX TAPE	\$67.76	
NCB	05/10/2023	1282	LOWE'S HOME CENTERS, INC.	10.0.1100.300.78.0000.00	FOAM KIT/CIST COVER/HITCH RING	\$229.93	
NCB	05/10/2023	1282	LOWE'S HOME CENTERS, INC.	20.0.2540.400.00.0000.01	MAINTENANCE PAINT	\$44.36	
NCB	05/10/2023	1282	LOWE'S HOME CENTERS, INC.	20.0.2540.400.00.0000.03	MAINTENANCE SUPPLIES	\$90.88	
						Check Total:	\$2,789.39
7400027674	05/04/2023	1273	MARY PETRIKO	10.0.1100.335.00.0000.00	EXPENSE REIMBURSEMENT/SUPPLIES	\$859.11	
						Check Total:	\$859.11
7400027675	05/04/2023	1273	MAXIM HEALTHCARE STAFFING SERVICES, INC.	10.0.2130.300.00.0000.01	ES-RN SCHOOL 1:1	\$2,812.50	

Lincolnwood School District 74

Disbursement Detail Listing

Bank Name: COLE TAYLOR BANK - ACCOUNTS PAYABLE Date Range: 05/01/2023 - 05/31/2023 Sort By: Vendor
 Voucher Range: - Dollar Limit: \$0.00

Fiscal Year: 2022-2023

Print Employee Vendor Names Exclude Voided Checks Exclude Manual Checks Include Non Check Batches

Check Number	Date	Voucher	Payee	Account	Description	Amount
7400027675	05/04/2023	1273	MAXIM HEALTHCARE STAFFING SERVICES, INC.	10.0.2130.300.00.0000.01	ES-RN SCHOOL 1:1	\$2,812.50
Check Total:						\$5,625.00
7400027734	05/18/2023	1297	MAXIM HEALTHCARE STAFFING SERVICES, INC.	10.0.2130.300.00.0000.01	ES-RN SCHOOL 1:1/4/24/23-4/28/23	\$2,812.50
7400027734	05/18/2023	1297	MAXIM HEALTHCARE STAFFING SERVICES, INC.	10.0.2130.300.00.0000.01	ES-RN SCHOOL 1:1	\$2,812.50
Check Total:						\$5,625.00
NCB	05/12/2023	1296	MB FINANCIAL BANK_SD74 FLEX	10.3.0499.900.00.0000.00	OTHER PAYROLL LIABILITIES	\$2,225.57
NCB	05/12/2023	1296	MB FINANCIAL BANK_SD74 FLEX	20.3.0499.900.00.0000.00	OTHER PAYROLL LIABILITIES	\$25.00
NCB	05/12/2023	1296	MB FINANCIAL BANK_SD74 FLEX	10.3.0499.900.00.0000.00	OTHER PAYROLL LIABILITIES	\$2,216.62
NCB	05/12/2023	1296	MB FINANCIAL BANK_SD74 FLEX	10.3.0499.900.00.0000.00	OTHER PAYROLL LIABILITIES	\$104.75
NCB	05/10/2023	1282	MICHAELS	10.0.1100.400.10.0000.01	5 DRAWER ROLLING CART	\$199.96
Check Total:						\$4,771.90
7400027676	05/04/2023	1273	MICHELLE LANGE-GAD	10.0.1100.439.00.0000.03	EXPENSE REIMBURSEMENT/BLOOKET	\$4.99
Check Total:						\$4.99
7400027677	05/04/2023	1273	MOSHE ERLICH	40.0.2550.331.35.0000.00	MILEAGE REIMBURSEMENT DUE TO MEDIATION	\$1,153.32
Check Total:						\$1,153.32
7400027678	05/04/2023	1273	MUSIC & ARTS CENTER, INC.	10.0.1100.323.31.0000.00	INSTRUMENT REPAIR	\$274.00
Check Total:						\$274.00
7400027735	05/18/2023	1297	MUSIC & ARTS CENTER, INC.	10.0.1100.323.31.0000.00	INSTRUMENT REPAIRS & PARTS	\$288.00
Check Total:						\$288.00
7400027736	05/18/2023	1297	MUTUAL OF OMAHA	10.3.0499.603.00.0000.00	LTD	\$3,339.66
Check Total:						\$3,339.66
7400027679	05/04/2023	1273	NANCY BOES	10.0.1100.338.42.0000.03	VOLLEYBALL OFFICIAL/2 GAMES/4/26/23	\$112.00
Check Total:						\$112.00
7400027737	05/18/2023	1297	NCS PEARSON, INC.	10.0.2140.400.00.0000.00	ESP Record Form Qty 25 (Print) Qualification Level B	\$67.80

Lincolnwood School District 74

Disbursement Detail Listing

Bank Name: COLE TAYLOR BANK - ACCOUNTS PAYABLE Date Range: 05/01/2023 - 05/31/2023 Sort By: Vendor
 Voucher Range: - Dollar Limit: \$0.00

Fiscal Year: 2022-2023

Print Employee Vendor Names Exclude Voided Checks Exclude Manual Checks Include Non Check Batches

Check Number	Date	Voucher	Payee	Account	Description	Amount
7400027737	05/18/2023	1297	NCS PEARSON, INC.	10.0.2150.400.00.0000.00	PLS-5 Record Forms Qual Lvl B 50ct	\$212.00
7400027737	05/18/2023	1297	NCS PEARSON, INC.	10.0.2150.400.00.0000.00	GFTA-3 Record Forms Qual Lvl B 25ct	\$53.00
7400027737	05/18/2023	1297	NCS PEARSON, INC.	10.0.2150.400.00.0000.00	CELf-5 Record Forms Qual Lvl B Ages 5-8 print 25 ct	\$98.05
7400027737	05/18/2023	1297	NCS PEARSON, INC.	10.0.2150.400.00.0000.00	CELf Preschool-2 Record Forms Qual Lvl B 25 ct	\$104.94
7400027737	05/18/2023	1297	NCS PEARSON, INC.	10.0.2150.400.00.0000.00	CELf-5 Screening Test Record Froms Qual Lvl B 25	\$42.93
Check Total:						\$578.72
7400027738	05/18/2023	1297	NICOR GAS	20.0.2540.465.00.0000.00	NATURAL GAS	\$282.33
7400027738	05/18/2023	1297	NICOR GAS	20.0.2540.465.00.0000.00	NATURAL GAS	\$303.32
Check Total:						\$585.65
7400027739	05/18/2023	1297	NILES TOWNSHIP DIST FOR SPECIAL EDUC 807	10.0.2140.300.00.0000.00	ADOS ASSESSMENT ON 2/3 & 2/24	\$1,290.00
Check Total:						\$1,290.00
7400027680	05/04/2023	1273	NILES TOWNSHIP SCHOOL TREASURER	10.0.2520.309.00.0000.00	FY2023 ANNUAL BILLING	\$93,520.00
Check Total:						\$93,520.00
7400027681	05/04/2023	1273	NORTH SHORE TRANSIT	40.0.2550.331.35.0000.00	MONTHLY ROUTE COST-MARCH 2023	\$47,222.22
Check Total:						\$47,222.22
7400027701	05/12/2023	1291	NORTH SUBURBAN TEACHERS' UNION	10.3.0499.900.00.0000.00	OTHER PAYROLL LIABILITIES	\$6,345.86
7400027701	05/12/2023	1291	NORTH SUBURBAN TEACHERS' UNION	10.3.0499.900.00.0000.00	OTHER PAYROLL LIABILITIES	\$1,123.28
7400027701	05/12/2023	1291	NORTH SUBURBAN TEACHERS' UNION	20.3.0499.900.00.0000.00	OTHER PAYROLL LIABILITIES	\$251.25
Check Total:						\$7,720.39
7400027682	05/04/2023	1273	NORTHLIGHT THEATRE	10.0.1100.300.78.0000.00	ARTISTIC STAFFING FOR LINCOLNWOOD SCHOOL	\$2,600.00
Check Total:						\$2,600.00

Lincolnwood School District 74

Disbursement Detail Listing

Bank Name: COLE TAYLOR BANK - ACCOUNTS PAYABLE Date Range: 05/01/2023 - 05/31/2023 Sort By: Vendor
 Voucher Range: - Dollar Limit: \$0.00

Fiscal Year: 2022-2023

Print Employee Vendor Names Exclude Voided Checks Exclude Manual Checks Include Non Check Batches

Check Number	Date	Voucher	Payee	Account	Description	Amount
NCB	05/10/2023	1282	NOTHING BUNDT CAKE	10.0.2310.315.00.0000.00	TAX REFUND	(\$2.52)
NCB	05/10/2023	1282	NOTHING BUNDT CAKE	10.0.2310.315.00.0000.00	BUNDTINIS CASE	\$96.00
						<u>Check Total:</u>
7400027740	05/18/2023	1297	NUTOYS LEISURE PRODUCTS	60.0.2530.500.00.4998.00	Rock-N-Ring Panel Ground Level	\$2,265.00
7400027740	05/18/2023	1297	NUTOYS LEISURE PRODUCTS	60.0.2530.500.00.4998.00	Tic-Tac-Toe Panel Ground Level	\$1,805.00
7400027740	05/18/2023	1297	NUTOYS LEISURE PRODUCTS	60.0.2530.500.00.4998.00	Xylofun Panel Ground Level	\$2,880.00
7400027740	05/18/2023	1297	NUTOYS LEISURE PRODUCTS	60.0.2530.500.00.4998.00	76" Alum Post DB	\$285.00
7400027740	05/18/2023	1297	NUTOYS LEISURE PRODUCTS	60.0.2530.500.00.4998.00	84" Alum Post DB	\$1,200.00
7400027740	05/18/2023	1297	NUTOYS LEISURE PRODUCTS	60.0.2530.500.00.4998.00	Rhapsody Goblet Drum Junior DB	\$1,555.00
7400027740	05/18/2023	1297	NUTOYS LEISURE PRODUCTS	60.0.2530.500.00.4998.00	Rhapsody Kettle Drum Junior DB	\$1,555.00
7400027740	05/18/2023	1297	NUTOYS LEISURE PRODUCTS	60.0.2530.500.00.4998.00	Rhapsody Kundu Drumb Junior DB	\$1,555.00
7400027740	05/18/2023	1297	NUTOYS LEISURE PRODUCTS	60.0.2530.500.00.4998.00	Rhapsody Warble Chimes DB	\$5,180.00
7400027740	05/18/2023	1297	NUTOYS LEISURE PRODUCTS	60.0.2530.500.00.4998.00	SwiggleKnots Bridge w/o Deck Connections DB Only	\$6,775.00
7400027740	05/18/2023	1297	NUTOYS LEISURE PRODUCTS	60.0.2530.500.00.4998.00	E-Pod Seat	\$680.00
7400027740	05/18/2023	1297	NUTOYS LEISURE PRODUCTS	60.0.2530.500.00.4998.00	Stationary Cycler Accessible	\$540.00
7400027740	05/18/2023	1297	NUTOYS LEISURE PRODUCTS	60.0.2530.500.00.4998.00	Stationary Cycler Pedals & Handles	\$1,765.00
7400027740	05/18/2023	1297	NUTOYS LEISURE PRODUCTS	60.0.2530.500.00.4998.00	Ring Pull	\$725.00
7400027740	05/18/2023	1297	NUTOYS LEISURE PRODUCTS	60.0.2530.500.00.4998.00	108" Alum Post DB	\$990.00
7400027740	05/18/2023	1297	NUTOYS LEISURE PRODUCTS	60.0.2530.500.00.4998.00	132" Alum Post DB	\$820.00
7400027740	05/18/2023	1297	NUTOYS LEISURE PRODUCTS	60.0.2530.500.00.4998.00	Wobble Pod DB Only	\$1,690.00
7400027740	05/18/2023	1297	NUTOYS LEISURE PRODUCTS	60.0.2530.500.00.4998.00	Chill Spinner DB	\$2,260.00

Lincolnwood School District 74

Disbursement Detail Listing

Bank Name: COLE TAYLOR BANK - ACCOUNTS PAYABLE Date Range: 05/01/2023 - 05/31/2023 Sort By: Vendor
 Voucher Range: - Dollar Limit: \$0.00

Fiscal Year: 2022-2023

Print Employee Vendor Names Exclude Voided Checks Exclude Manual Checks Include Non Check Batches

Check Number	Date	Voucher	Payee	Account	Description	Amount	
7400027740	05/18/2023	1297	NUTOYS LEISURE PRODUCTS	60.0.2530.500.00.4998.00	Shipping Cost	\$1,739.00	
						Check Total:	\$36,264.00
7400027683	05/04/2023	1273	O'HARE MECHANICAL CONTRACTORS INC.	20.0.2540.320.00.0000.01	LABOR AND MATERIAL	\$667.50	
7400027683	05/04/2023	1273	O'HARE MECHANICAL CONTRACTORS INC.	20.0.2540.320.00.0000.02	LABOR	\$570.00	
						Check Total:	\$1,237.50
7400027684	05/04/2023	1273	OCONOMOWOC DEVELOPMENTAL TRAINING	10.0.4120.670.35.0000.00	TUITION-REGULAR	\$5,790.60	
7400027684	05/04/2023	1273	OCONOMOWOC DEVELOPMENTAL TRAINING	10.0.4120.670.35.0000.00	RESIDENTIAL	\$13,996.80	
						Check Total:	\$19,787.40
NCB	05/10/2023	1282	ORIENTAL TRADING CO. INC.	10.0.1100.411.00.0000.02	BRAIN BREAK ACTIVITY DICE	\$48.34	
						Check Total:	\$48.34
7400027685	05/04/2023	1273	ORIENTAL TRADING CO. INC.	10.0.1100.410.25.0000.01	Superhero chest	\$135.31	
7400027685	05/04/2023	1273	ORIENTAL TRADING CO. INC.	10.0.1100.410.25.0000.01	Mini bubbles	\$9.91	
7400027685	05/04/2023	1273	ORIENTAL TRADING CO. INC.	10.0.1100.410.25.0000.01	Guitar bubbles	\$13.53	
7400027685	05/04/2023	1273	ORIENTAL TRADING CO. INC.	10.0.1100.449.00.0000.01	PBIS MATERIALS - TODD HALL	\$237.20	
7400027685	05/04/2023	1273	ORIENTAL TRADING CO. INC.	10.0.1100.449.00.0000.01	Sensory Fidget Assortment	\$243.12	
7400027685	05/04/2023	1273	ORIENTAL TRADING CO. INC.	10.0.1100.449.00.0000.01	Rainbow Mini Slime Assortment	\$39.76	
7400027685	05/04/2023	1273	ORIENTAL TRADING CO. INC.	10.0.1100.449.00.0000.01	Tropical Novelty Assortment	\$117.14	
7400027685	05/04/2023	1273	ORIENTAL TRADING CO. INC.	10.0.1100.449.00.0000.01	Bubble Assortment	\$49.73	
7400027685	05/04/2023	1273	ORIENTAL TRADING CO. INC.	10.0.1100.449.00.0000.01	Pull-Back Car Assortment	\$165.77	
7400027685	05/04/2023	1273	ORIENTAL TRADING CO. INC.	10.0.1100.449.00.0000.01	Mega Deluxe Toy Assortment	\$110.51	
7400027685	05/04/2023	1273	ORIENTAL TRADING CO. INC.	10.0.1100.449.00.0000.01	Mini Pet Shot Animal Assortment	\$132.61	
7400027685	05/04/2023	1273	ORIENTAL TRADING CO. INC.	10.0.1100.449.00.0000.01	Glitter Sticky Hands	\$66.25	
7400027685	05/04/2023	1273	ORIENTAL TRADING CO. INC.	10.0.1100.449.00.0000.01	Stress Toy Assortment	\$121.55	
						Check Total:	\$1,442.39

Lincolnwood School District 74

Disbursement Detail Listing

Bank Name: COLE TAYLOR BANK - ACCOUNTS PAYABLE Date Range: 05/01/2023 - 05/31/2023 Sort By: Vendor
 Voucher Range: - Dollar Limit: \$0.00

Fiscal Year: 2022-2023

Print Employee Vendor Names
 Exclude Voided Checks
 Exclude Manual Checks
 Include Non Check Batches

Check Number	Date	Voucher	Payee	Account	Description	Amount	
NCB	05/10/2023	1282	PEARSON EDUCATION INC.	10.0.1100.417.00.0000.01	SPEED DIAL RECORD FORMS	\$208.93	
NCB	05/12/2023	1295	PLANMEMBER	10.3.0499.500.00.0000.00	ANNUITIES PAYABLE	\$100.00	
NCB	05/12/2023	1295	PLANMEMBER	20.3.0499.500.00.0000.00	ANNUITIES PAYABLE	\$600.00	
NCB	05/12/2023	1295	PLANMEMBER	10.3.0499.500.00.0000.00	ANNUITIES PAYABLE	\$75.00	
						Check Total:	\$983.93
7400027686	05/04/2023	1273	PROGRESSIVE TREE SERVICE	20.0.2540.540.00.0000.03	TREE REMOVAL	\$1,430.00	
						Check Total:	\$1,430.00
7400027687	05/04/2023	1273	PROJECT LEAD THE WAY	10.0.1100.400.19.0000.03	3M TEMFLEX VINYL ELECTRICAL TAPE, 5 PACK	\$18.50	
7400027687	05/04/2023	1273	PROJECT LEAD THE WAY	10.0.1100.400.19.0000.03	9V BATTERY, 12 PACK	\$48.00	
7400027687	05/04/2023	1273	PROJECT LEAD THE WAY	10.0.1100.400.19.0000.03	AA BATTERY HOLDER, 10 PACK	\$83.75	
7400027687	05/04/2023	1273	PROJECT LEAD THE WAY	10.0.1100.400.19.0000.03	AA BATTERY, 10 PACK	\$60.00	
7400027687	05/04/2023	1273	PROJECT LEAD THE WAY	10.0.1100.400.19.0000.03	COLORED PERMANENT MARKER, 8 PACK	\$13.00	
7400027687	05/04/2023	1273	PROJECT LEAD THE WAY	10.0.1100.400.19.0000.03	ENAMEL MAGNET WIRE, 22 GAUGE, 500 FT	\$44.00	
7400027687	05/04/2023	1273	PROJECT LEAD THE WAY	10.0.1100.400.19.0000.03	LEADS WITH ALLIGATOR CLIP ENDS, 10 PACKS OF 10	\$32.50	
7400027687	05/04/2023	1273	PROJECT LEAD THE WAY	10.0.1100.400.19.0000.03	LO-TEMP GLUE STICK 50-PACK, 1/2" DIAMETER X	\$16.00	
7400027687	05/04/2023	1273	PROJECT LEAD THE WAY	10.0.1100.400.19.0000.03	MACHINE SCREW, 8-32 X 1/2", PAN HEAD, PHILLIPS,	\$12.00	
7400027687	05/04/2023	1273	PROJECT LEAD THE WAY	10.0.1100.400.19.0000.03	MAGLEV MAGNETS, 250	\$125.50	
7400027687	05/04/2023	1273	PROJECT LEAD THE WAY	10.0.1100.400.19.0000.03	NAILS 20D, 4 INCH, 1 LB	\$39.00	
7400027687	05/04/2023	1273	PROJECT LEAD THE WAY	10.0.1100.400.19.0000.03	RESISTORS, FIXED, ASSORTED 60 PACK	\$22.50	
7400027687	05/04/2023	1273	PROJECT LEAD THE WAY	10.0.1100.400.19.0000.03	RUBBER BANDS, 0.25 INCH X 3.5 INCH, #64	\$5.75	

Lincolnwood School District 74

Disbursement Detail Listing

Bank Name: COLE TAYLOR BANK - ACCOUNTS PAYABLE Date Range: 05/01/2023 - 05/31/2023 Sort By: Vendor
 Voucher Range: - Dollar Limit: \$0.00

Fiscal Year: 2022-2023

Print Employee Vendor Names Exclude Voided Checks Exclude Manual Checks Include Non Check Batches

Check Number	Date	Voucher	Payee	Account	Description	Amount
7400027687	05/04/2023	1273	PROJECT LEAD THE WAY	10.0.1100.400.19.0000.03	RULER, CLEAR PLASTIC, 12 INCH / 31 CM, METRIC AND	\$24.00
7400027687	05/04/2023	1273	PROJECT LEAD THE WAY	10.0.1100.400.19.0000.03	SCISSORS, 8 INCH, PLASTIC HANDLE, POINTED TIP, BOX	\$66.00
7400027687	05/04/2023	1273	PROJECT LEAD THE WAY	10.0.1100.400.19.0000.03	SNAP CIRCUIT KIT - MAGIC OF ELECTRONS	\$320.00
7400027687	05/04/2023	1273	PROJECT LEAD THE WAY	10.0.1100.400.19.0000.03	WIRE, COPPER, 14 GAUGE LOW VOLTAGE, 4 FT	\$12.00
Check Total:						\$942.50
NCB	05/10/2023	1282	RAPTOR TECHNOLOGIES INC.	10.0.1100.412.05.0000.00	VISITOR BADGES	\$50.00
NCB	05/10/2023	1282	REALLY GOOD STUFF	10.0.2410.400.00.0000.02	PRIVACY SHIELDS	\$68.09
NCB	05/10/2023	1282	RESTAURANT DEPOT	20.0.2540.416.00.0000.03	SKYLINE SCALEAWAU	\$49.65
NCB	05/10/2023	1282	RUSSO POWER EQUIPMENT	20.0.2540.404.00.0000.04	GROUNDS SUPPLIES - ADMIN BLDG BX2537AKUB	\$2,664.00
Check Total:						\$2,831.74
7400027688	05/04/2023	1273	RUSTY SILBER	10.0.1100.338.42.0000.03	JV SOCCER/4/27/23	\$63.00
Check Total:						\$63.00
NCB	05/10/2023	1282	SAM'S CLUB	10.0.2560.410.00.0000.00	COKE/SPRITE/PEPSI/WATER	\$132.20
NCB	05/10/2023	1282	SAM'S CLUB	10.0.2520.400.00.0000.00	KITCHEN SUPPLIES	\$443.28
Check Total:						\$575.48
7400027741	05/18/2023	1297	SAVANNAH COLLEGE OF ART & DESIGN	10.0.2630.300.00.0000.00	CAHILL SCHOLARSHIP AWARD/CAITLIN JOANN	\$500.00
Check Total:						\$500.00
NCB	05/10/2023	1282	SCHLEGL'S	10.0.2310.315.00.0000.00	BOE MEETING/BAKERY	\$59.50
Check Total:						\$59.50
7400027689	05/04/2023	1273	SCHOOL DISTRICT #74	10.2.0111.000.00.0000.00	REIMB/BETTER HOMES DISTRIBUTORS LLC	\$2,093.98
Check Total:						\$2,093.98
7400027690	05/04/2023	1273	SCHOOL SPECIALTY	10.0.1100.410.23.0000.03	School Smart Poster Boards, 22 x 28 Inches, 8-Ply	\$56.98

Lincolnwood School District 74

Disbursement Detail Listing

Bank Name: COLE TAYLOR BANK - ACCOUNTS PAYABLE Date Range: 05/01/2023 - 05/31/2023 Sort By: Vendor
 Voucher Range: - Dollar Limit: \$0.00

Fiscal Year: 2022-2023

Print Employee Vendor Names
 Exclude Voided Checks
 Exclude Manual Checks
 Include Non Check Batches

Check Number	Date	Voucher	Payee	Account	Description	Amount
7400027690	05/04/2023	1273	SCHOOL SPECIALTY	10.0.1100.410.23.0000.03	School Smart Dual Temperature Mini Glue	\$30.00
7400027690	05/04/2023	1273	SCHOOL SPECIALTY	10.0.1100.410.23.0000.03	Creativity Street Jumbo Natural Wood Crafts Sticks,	\$16.20
7400027690	05/04/2023	1273	SCHOOL SPECIALTY	10.0.1100.400.18.0000.03	EXPO Low Odor Dry Erase Markers, Chisel Tip,	\$49.67
7400027690	05/04/2023	1273	SCHOOL SPECIALTY	10.0.1100.400.18.0000.03	EXPO Low Odor Dry Erase Marker, Chisel Tip, Blue,	\$18.21
7400027690	05/04/2023	1273	SCHOOL SPECIALTY	10.0.1100.400.18.0000.03	Sharpie Fine Point Color Burst Permanent Markers	\$26.70
7400027690	05/04/2023	1273	SCHOOL SPECIALTY	10.0.1100.400.18.0000.03	EXPO Precision Point Eraser Refill Pad, for Use with	\$4.13
7400027690	05/04/2023	1273	SCHOOL SPECIALTY	10.0.1100.400.18.0000.03	The Pencil Grip Inc Magnetic Dry Erase Whiteboard	\$11.03
7400027690	05/04/2023	1273	SCHOOL SPECIALTY	10.0.1100.400.18.0000.03	School Smart Glue Sticks, 0.28 Ounces, Purple and	\$12.90
7400027690	05/04/2023	1273	SCHOOL SPECIALTY	10.0.1100.700.00.0000.01	Professional Library Book Shelves	\$729.58
7400027690	05/04/2023	1273	SCHOOL SPECIALTY	10.0.1800.400.00.0000.03	Colored Pencils	\$4.19
7400027690	05/04/2023	1273	SCHOOL SPECIALTY	10.0.1800.400.00.0000.03	erasers	\$7.49
7400027690	05/04/2023	1273	SCHOOL SPECIALTY	10.0.1800.400.00.0000.03	Eraser caps	\$10.49
7400027690	05/04/2023	1273	SCHOOL SPECIALTY	10.0.1800.400.00.0000.03	Pencils	\$20.99
7400027690	05/04/2023	1273	SCHOOL SPECIALTY	10.0.1800.400.00.0000.03	markers	\$6.82
7400027690	05/04/2023	1273	SCHOOL SPECIALTY	10.0.1800.400.00.0000.03	Index cards	\$2.32
7400027690	05/04/2023	1273	SCHOOL SPECIALTY	10.0.1800.400.00.0000.03	small paper clips	\$1.27
7400027690	05/04/2023	1273	SCHOOL SPECIALTY	10.0.1800.400.00.0000.03	EL SUPPLIES & MATERIALS LH	\$1.49
7400027690	05/04/2023	1273	SCHOOL SPECIALTY	10.0.1125.450.09.0000.01	Do a Dot Art Sponge Tip Paint Markers Classroom	\$73.13

Lincolnwood School District 74

Disbursement Detail Listing

Bank Name: COLE TAYLOR BANK - ACCOUNTS PAYABLE Date Range: 05/01/2023 - 05/31/2023 Sort By: Vendor
 Voucher Range: - Dollar Limit: \$0.00

Fiscal Year: 2022-2023

Print Employee Vendor Names
 Exclude Voided Checks
 Exclude Manual Checks
 Include Non Check Batches

Check Number	Date	Voucher	Payee	Account	Description	Amount
7400027690	05/04/2023	1273	SCHOOL SPECIALTY	10.0.1100.410.00.0000.01	Highland 1-1/2 x 2in Notes	\$35.94
7400027690	05/04/2023	1273	SCHOOL SPECIALTY	10.0.1100.410.00.0000.01	Post-It 3x3 Floral Fantasy Colors	\$58.02
7400027690	05/04/2023	1273	SCHOOL SPECIALTY	10.0.1100.410.00.0000.01	Paper Mate Pencil Cap Erasers	\$33.96
7400027690	05/04/2023	1273	SCHOOL SPECIALTY	10.0.1100.410.00.0000.01	Tru-Ray Sulphite 12x18 Construction Paper	\$45.52
7400027690	05/04/2023	1273	SCHOOL SPECIALTY	10.0.1100.410.00.0000.01	Tru-Ray White 12x18 Paper	\$56.90
7400027690	05/04/2023	1273	SCHOOL SPECIALTY	10.0.1100.410.00.0000.01	Tru-Ray Yellow 12x18 Construction Paper	\$45.52
7400027690	05/04/2023	1273	SCHOOL SPECIALTY	10.0.1100.410.00.0000.01	Tru-Ray Violet 12x18 Paper	\$45.52
7400027690	05/04/2023	1273	SCHOOL SPECIALTY	10.0.1100.410.00.0000.01	Tru-Ray Violet 9x12 Paper	\$25.76
7400027690	05/04/2023	1273	SCHOOL SPECIALTY	10.0.1100.410.00.0000.01	Prang 9x12 Blue Paper	\$17.92
7400027690	05/04/2023	1273	SCHOOL SPECIALTY	10.0.1100.410.00.0000.01	Prang Sky Blue 9x12 Paper	\$17.92
7400027690	05/04/2023	1273	SCHOOL SPECIALTY	10.0.1100.410.00.0000.01	Prang Sky Blue 12x18 Paper	\$30.56
7400027690	05/04/2023	1273	SCHOOL SPECIALTY	10.0.1100.410.00.0000.01	Green 2-Pocket Folder	\$94.44
7400027690	05/04/2023	1273	SCHOOL SPECIALTY	10.0.1100.410.00.0000.01	Paper Mate Eraser Pink	\$70.14
7400027690	05/04/2023	1273	SCHOOL SPECIALTY	10.0.1100.410.00.0000.01	No. 2 Pencil Pack of 144	\$170.52
7400027690	05/04/2023	1273	SCHOOL SPECIALTY	10.0.1100.423.36.0000.03	Califone 8200HP-20L Lightweight On-Ear Stereo	\$99.33
7400027690	05/04/2023	1273	SCHOOL SPECIALTY	10.0.1100.423.36.0000.03	School Smart Reusable Dry Erase Pockets, 10-1/2 x 13	\$43.65
7400027690	05/04/2023	1273	SCHOOL SPECIALTY	10.0.1100.410.24.0000.03	Sax True Flow Gloss Glaze, Wisteria Purple, 1 Gallon	\$149.02
7400027690	05/04/2023	1273	SCHOOL SPECIALTY	10.0.1100.400.17.0000.03	3M 201+ General Use Masking Tape, 1 Inch x 60	\$23.75

Lincolnwood School District 74

Disbursement Detail Listing

Bank Name: COLE TAYLOR BANK - ACCOUNTS PAYABLE Date Range: 05/01/2023 - 05/31/2023 Sort By: Vendor
 Voucher Range: - Dollar Limit: \$0.00

Fiscal Year: 2022-2023

Print Employee Vendor Names
 Exclude Voided Checks
 Exclude Manual Checks
 Include Non Check Batches

Check Number	Date	Voucher	Payee	Account	Description	Amount
7400027690	05/04/2023	1273	SCHOOL SPECIALTY	10.0.1100.400.17.0000.03	Scotch Duct Tape, 1.88 Inches x 20 Yards, Jet Black	\$12.00
7400027690	05/04/2023	1273	SCHOOL SPECIALTY	10.0.1100.400.17.0000.03	School Smart Professional Colored Pencils, Assorted	\$76.38
7400027690	05/04/2023	1273	SCHOOL SPECIALTY	10.0.1100.400.17.0000.03	Crayola Watercolor Colored Pencil Class Pack, 12	\$65.54
7400027690	05/04/2023	1273	SCHOOL SPECIALTY	10.0.1100.400.17.0000.03	Tru-Ray Sulphite Construction Paper, 18 x 24	\$10.83
7400027690	05/04/2023	1273	SCHOOL SPECIALTY	10.0.1100.400.17.0000.03	Pacon Heavyweight Tagboard, 9 x 12 Inches, 11	\$4.33
7400027690	05/04/2023	1273	SCHOOL SPECIALTY	10.0.1100.423.36.0000.03	Business Source Hardboard Clipboard, 9 x 12-1/2, Pack	\$73.68
7400027690	05/04/2023	1273	SCHOOL SPECIALTY	10.0.1250.400.00.0000.02	EXPO Low Odor Dry Erase Markers, Chisel Tip,	\$49.67
7400027690	05/04/2023	1273	SCHOOL SPECIALTY	10.0.1250.400.00.0000.02	School Smart Traditional No 2 Pencils, Assorted Colors,	\$26.14
7400027690	05/04/2023	1273	SCHOOL SPECIALTY	10.0.1250.400.00.0000.02	Eureka Bookmarks, Marshmallow Scented, 2 x 6	\$11.30
7400027690	05/04/2023	1273	SCHOOL SPECIALTY	10.0.1250.400.00.0000.02	School Smart Polypropylene D-Ring Binder, 1-1/2	\$13.92
7400027690	05/04/2023	1273	SCHOOL SPECIALTY	10.0.1250.400.00.0000.02	School Smart Polypropylene Round Ring Binder, 1-1/2	\$29.65
7400027690	05/04/2023	1273	SCHOOL SPECIALTY	10.0.1250.400.00.0000.02	School Smart Magnetic Whiteboard Eraser, 2 x 4	\$4.20
7400027690	05/04/2023	1273	SCHOOL SPECIALTY	10.0.1250.400.00.0000.02	Trend Enterprises Bugs and Blooms Scratch N Sniff	\$9.65
7400027690	05/04/2023	1273	SCHOOL SPECIALTY	10.0.1250.400.00.0000.02	Frey Scientific Stopwatches, 100 Minutes, 1/100th	\$7.93
Check Total:						\$2,543.20

Lincolnwood School District 74

Disbursement Detail Listing

Bank Name: COLE TAYLOR BANK - ACCOUNTS PAYABLE Date Range: 05/01/2023 - 05/31/2023 Sort By: Vendor
 Voucher Range: - Dollar Limit: \$0.00

Fiscal Year: 2022-2023

Print Employee Vendor Names
 Exclude Voided Checks
 Exclude Manual Checks
 Include Non Check Batches

Check Number	Date	Voucher	Payee	Account	Description	Amount
7400027742	05/18/2023	1297	SCHOOL SPECIALTY	10.0.1100.410.24.0000.03	AMACO Gloss Glaze, Gallon, Opaque White LG-11, Each	\$160.06
7400027742	05/18/2023	1297	SCHOOL SPECIALTY	10.0.1100.410.24.0000.03	Sax True Flow Gloss Glaze, Mosaic Blue, 1 Gallon	\$74.51
7400027742	05/18/2023	1297	SCHOOL SPECIALTY	10.0.1100.410.24.0000.03	Mayco Jungle Gems Crystal Glaze, Dragon's Breath	\$18.42
7400027742	05/18/2023	1297	SCHOOL SPECIALTY	10.0.1100.410.24.0000.03	Mayco Jungle Gems Crystal Glaze, Bloomin' Blue CG974,	\$18.42
7400027742	05/18/2023	1297	SCHOOL SPECIALTY	10.0.1100.410.24.0000.03	Mayco Jungle Gems Crystal Glaze, Pagoda Green	\$18.42
7400027742	05/18/2023	1297	SCHOOL SPECIALTY	10.0.1100.439.00.0000.03	Elmer's CraftBond Full Size Hot Glue Gun, Dual Temp	\$55.16
7400027742	05/18/2023	1297	SCHOOL SPECIALTY	10.0.1100.439.00.0000.03	School Smart All Temperature Glue Stick,	\$39.72
7400027742	05/18/2023	1297	SCHOOL SPECIALTY	10.0.1100.439.00.0000.03	School Smart Glue Sticks, 0.28 Ounces, Purple and	\$51.60
7400027742	05/18/2023	1297	SCHOOL SPECIALTY	10.0.1100.439.00.0000.03	School Smart 2-Pocket Poly Folders with Fasteners,	\$67.80
7400027742	05/18/2023	1297	SCHOOL SPECIALTY	10.0.1100.439.00.0000.03	Crayola Colored Pencil Classpack with 12	\$43.67
7400027742	05/18/2023	1297	SCHOOL SPECIALTY	10.0.1100.439.00.0000.03	School Smart Washable Tempera Paint Set, Assorted	\$22.97
7400027742	05/18/2023	1297	SCHOOL SPECIALTY	10.0.1100.439.00.0000.03	School Smart Washable Tempera Paint, Quart, White	\$6.50
7400027742	05/18/2023	1297	SCHOOL SPECIALTY	10.0.1100.439.00.0000.03	Sax True Flow Heavy Body Acrylic Paint, Assorted	\$63.47
7400027742	05/18/2023	1297	SCHOOL SPECIALTY	10.0.1100.439.00.0000.03	Red Sharpie pack of 12	\$12.11
7400027742	05/18/2023	1297	SCHOOL SPECIALTY	10.0.1100.439.00.0000.03	Mint Mosaic Masking Tape	\$4.62
7400027742	05/18/2023	1297	SCHOOL SPECIALTY	10.0.1100.439.00.0000.03	Duct tape	\$6.62

Lincolnwood School District 74

Disbursement Detail Listing

Bank Name: COLE TAYLOR BANK - ACCOUNTS PAYABLE Date Range: 05/01/2023 - 05/31/2023 Sort By: Vendor
 Voucher Range: - Dollar Limit: \$0.00

Fiscal Year: 2022-2023

Print Employee Vendor Names
 Exclude Voided Checks
 Exclude Manual Checks
 Include Non Check Batches

Check Number	Date	Voucher	Payee	Account	Description	Amount
7400027742	05/18/2023	1297	SCHOOL SPECIALTY	10.0.1100.439.00.0000.03	washable tempera quart set of 12	\$52.09
7400027742	05/18/2023	1297	SCHOOL SPECIALTY	10.0.1100.439.00.0000.03	Childcraft Construction Paper, 9 x 12 Inches,	\$24.82
7400027742	05/18/2023	1297	SCHOOL SPECIALTY	10.0.1100.439.00.0000.03	School Smart Low Odor Non-Toxic Dry Erase Tank	\$46.02
7400027742	05/18/2023	1297	SCHOOL SPECIALTY	10.0.1100.439.00.0000.03	Scotch Heavy Duty Shipping Packaging Tape, 1.88 Inches	\$27.59
7400027742	05/18/2023	1297	SCHOOL SPECIALTY	10.0.1100.439.00.0000.03	School Smart Hexagonal Pencils, No 2, Pack of 144	\$19.20
7400027742	05/18/2023	1297	SCHOOL SPECIALTY	10.0.1100.439.00.0000.03	Mechanical Pencils Pack of 36	\$21.18
7400027742	05/18/2023	1297	SCHOOL SPECIALTY	10.0.1100.439.00.0000.03	Index cards	\$1.36
7400027742	05/18/2023	1297	SCHOOL SPECIALTY	10.0.1100.439.00.0000.03	School Smart All Temperature Glue Stick,	\$7.51
7400027742	05/18/2023	1297	SCHOOL SPECIALTY	10.0.1100.439.00.0000.03	Crystalware Aluminum Lids, 20 x 13 in, Pack of 50	\$58.23
7400027742	05/18/2023	1297	SCHOOL SPECIALTY	10.0.1200.400.00.0000.03	Paper Mate Write Bros. Strong Mechanical Pencils,	\$9.17
7400027742	05/18/2023	1297	SCHOOL SPECIALTY	10.0.1200.400.00.0000.03	School Smart Low-Profile Acrylic Clipboard, 12-3/8 x	\$16.20
7400027742	05/18/2023	1297	SCHOOL SPECIALTY	10.0.1200.400.00.0000.03	Post-It Self-Stick Easel Pad, 25 x 30 Inches, Grid Ruled,	\$231.82
7400027742	05/18/2023	1297	SCHOOL SPECIALTY	10.0.1200.400.00.0000.03	Theraputty CanDo Standard Exercise Putty, Assorted	\$123.88
7400027742	05/18/2023	1297	SCHOOL SPECIALTY	10.0.1200.400.00.0000.03	Samsill Earth Choice Fashion View Binder, Round Ring,	\$60.21
7400027742	05/18/2023	1297	SCHOOL SPECIALTY	10.0.1200.400.00.0000.03	StikkiWorks Stikki Dots Mounting Adhesive,	\$4.15

Lincolnwood School District 74

Disbursement Detail Listing

Bank Name: COLE TAYLOR BANK - ACCOUNTS PAYABLE Date Range: 05/01/2023 - 05/31/2023 Sort By: Vendor
 Voucher Range: - Dollar Limit: \$0.00

Fiscal Year: 2022-2023

Print Employee Vendor Names Exclude Voided Checks Exclude Manual Checks Include Non Check Batches

Check Number	Date	Voucher	Payee	Account	Description	Amount
7400027742	05/18/2023	1297	SCHOOL SPECIALTY	10.0.1200.400.00.0000.03	Pendaflex Twisted Glow File Folders, Letter Size, 3 Tab,	\$16.28
7400027742	05/18/2023	1297	SCHOOL SPECIALTY	10.0.1200.400.00.0000.03	Pendaflex Glow File Folders, Letter Size, 3 Tab, Assorted	\$11.79
7400027742	05/18/2023	1297	SCHOOL SPECIALTY	10.0.1100.410.23.0000.03	Flipside Two-Sided Dry Erase Board with Pen, 9 x 12	\$95.70
7400027742	05/18/2023	1297	SCHOOL SPECIALTY	10.0.1200.400.00.0000.03	Post-It Self-Stick Easel Pad, 25 x 30 Inches, Ruled,	\$239.14
Check Total:						\$1,730.41
7400027743	05/18/2023	1297	SECURITY UNLIMITED, INC.	20.0.2540.320.00.0000.01	Todd Maintenance Services -1. Furnish and install cable	\$1,520.00
Check Total:						\$1,520.00
NCB	05/10/2023	1282	SHERWIN-WILLIAMS	10.0.1100.300.78.0000.00	4 WIRE ROLLER/LITTLE MERMAID	\$27.49
Check Total:						\$27.49
7400027691	05/04/2023	1273	SMITHEREEN COMPANY	20.0.2540.320.00.0000.04	ADMIN BUILDING/TARET PESTS	\$45.00
7400027691	05/04/2023	1273	SMITHEREEN COMPANY	20.0.2540.320.00.0000.02	REGULARLY SCHEDULED PC SERVICE/RUTLEDGE HALL	\$71.00
7400027691	05/04/2023	1273	SMITHEREEN COMPANY	20.0.2540.320.00.0000.03	REGULARLY SCHEDULED PC SERVICE/LH	\$78.00
7400027691	05/04/2023	1273	SMITHEREEN COMPANY	20.0.2540.320.00.0000.01	TARGET PESTS/TODD HALL	\$61.00
Check Total:						\$255.00
7400027692	05/04/2023	1273	SOTIRIA GIKAS	10.0.2560.400.00.0000.00	WORK SHOES/WORK SLACKS	\$91.49
Check Total:						\$91.49
7400027744	05/18/2023	1297	SOUTHWEST EMBLEM	10.0.1100.425.00.0000.03	New Solo/Ensemble Silver Blue Drape	\$363.55
7400027744	05/18/2023	1297	SOUTHWEST EMBLEM	10.0.1100.425.00.0000.03	New Solo/Ensemble Silver Red Drape	\$94.10
Check Total:						\$457.65
NCB	05/10/2023	1282	STARBUCKS	10.0.1100.450.18.0000.03	GIFT CARDS	\$25.00

Lincolnwood School District 74

Disbursement Detail Listing

Bank Name: COLE TAYLOR BANK - ACCOUNTS PAYABLE Date Range: 05/01/2023 - 05/31/2023 Sort By: Vendor
 Voucher Range: - Dollar Limit: \$0.00

Fiscal Year: 2022-2023

Print Employee Vendor Names Exclude Voided Checks Exclude Manual Checks Include Non Check Batches

Check Number	Date	Voucher	Payee	Account	Description	Amount	
						Check Total:	\$25.00
7400027702	05/12/2023	1291	STATE DISBURSEMENT UNIT	10.3.0499.900.00.0000.00	OTHER PAYROLL LIABILITIES	\$1,079.00	
						Check Total:	\$1,079.00
7400027745	05/18/2023	1297	STEPHEN GERBER	10.0.1100.400.19.0000.03	EXPENSE REIMBURSEMENT/LEMONS	\$21.78	
						Check Total:	\$21.78
7400027746	05/18/2023	1297	STUDIO GC	60.0.2530.319.00.0000.00	PREK & KINDERGARTEN FURNITURE	\$131.78	
						Check Total:	\$131.78
7400027693	05/04/2023	1273	SYSCO FOOD SERVICES-CHICAGO	10.0.2560.410.00.0000.00	BAGEL/CORN COB/PASTA	\$793.63	
7400027693	05/04/2023	1273	SYSCO FOOD SERVICES-CHICAGO	10.0.2560.410.00.0000.00	AMER	\$803.24	
						Check Total:	\$1,596.87
7400027747	05/18/2023	1297	SYSCO FOOD SERVICES-CHICAGO	10.0.2560.410.00.0000.00	CHEESE/BAGEL/CORN/JELLY	\$937.19	
7400027747	05/18/2023	1297	SYSCO FOOD SERVICES-CHICAGO	10.0.2560.410.00.0000.00	CHEESE/EGG/BAGEL/CROUT	\$602.79	
7400027747	05/18/2023	1297	SYSCO FOOD SERVICES-CHICAGO	10.0.2560.410.00.0000.00	CREDIT	(\$50.00)	
7400027747	05/18/2023	1297	SYSCO FOOD SERVICES-CHICAGO	10.0.2560.410.00.0000.00	AMER CHEESE/BAGEL/GREEN	\$906.64	
						Check Total:	\$2,396.62
NCB	05/10/2023	1282	TARGET	10.0.1100.411.00.0000.02	KLEENEX	\$35.16	
NCB	05/10/2023	1282	TARGET	10.0.1100.449.00.0000.03	GIFT CARDS	\$135.00	
NCB	05/10/2023	1282	TARGET	10.0.1100.449.00.0000.03	SPRITZ	\$7.00	
						Check Total:	\$177.16
7400027748	05/18/2023	1297	TEACHERS DISCOVERY	10.0.1100.410.23.0000.03	Think like a Historian poster	\$16.49	
7400027748	05/18/2023	1297	TEACHERS DISCOVERY	10.0.1100.410.23.0000.03	Inquiry Book	\$19.79	
7400027748	05/18/2023	1297	TEACHERS DISCOVERY	10.0.1100.410.23.0000.03	SOCIAL STUDIES SUPPLIES - LINCOLN	\$27.49	
7400027748	05/18/2023	1297	TEACHERS DISCOVERY	10.0.1100.410.23.0000.03	Timeline	\$23.09	
7400027748	05/18/2023	1297	TEACHERS DISCOVERY	10.0.1100.410.23.0000.03	Timeline Events Game	\$10.99	

Lincolnwood School District 74

Disbursement Detail Listing

Bank Name: COLE TAYLOR BANK - ACCOUNTS PAYABLE Date Range: 05/01/2023 - 05/31/2023 Sort By: Vendor
 Voucher Range: - Dollar Limit: \$0.00

Fiscal Year: 2022-2023

Print Employee Vendor Names
 Exclude Voided Checks
 Exclude Manual Checks
 Include Non Check Batches

Check Number	Date	Voucher	Payee	Account	Description	Amount
7400027748	05/18/2023	1297	TEACHERS DISCOVERY	10.0.1100.410.23.0000.03	Timeline classic game	\$10.99
7400027748	05/18/2023	1297	TEACHERS DISCOVERY	10.0.1100.410.23.0000.03	SOCIAL STUDIES SUPPLIES – LINCOLN	\$10.99
7400027748	05/18/2023	1297	TEACHERS DISCOVERY	10.0.1100.410.23.0000.03	Stickers	\$16.45
7400027748	05/18/2023	1297	TEACHERS DISCOVERY	10.0.1100.410.23.0000.03	Greek Poster	\$18.70
7400027748	05/18/2023	1297	TEACHERS DISCOVERY	10.0.1100.410.23.0000.03	DBQ Poster	\$34.09
7400027748	05/18/2023	1297	TEACHERS DISCOVERY	10.0.1100.410.23.0000.03	Place in History poster	\$7.15
7400027748	05/18/2023	1297	TEACHERS DISCOVERY	10.0.1100.410.23.0000.03	Win The Response poster	\$18.70
7400027748	05/18/2023	1297	TEACHERS DISCOVERY	10.0.1100.410.23.0000.03	Women's History Poster	\$31.89
7400027748	05/18/2023	1297	TEACHERS DISCOVERY	10.0.1100.410.23.0000.03	Egypt Poster	\$23.09
7400027748	05/18/2023	1297	TEACHERS DISCOVERY	10.0.1100.410.23.0000.03	Stars and Strips Border	\$4.95
7400027748	05/18/2023	1297	TEACHERS DISCOVERY	10.0.1100.410.23.0000.03	Border	\$4.39
7400027748	05/18/2023	1297	TEACHERS DISCOVERY	10.0.1100.410.23.0000.03	Border	\$4.39
7400027748	05/18/2023	1297	TEACHERS DISCOVERY	10.0.1100.410.23.0000.03	Great Women poster	\$16.49
7400027748	05/18/2023	1297	TEACHERS DISCOVERY	10.0.1100.410.23.0000.03	Pyramid kit	\$131.96
7400027748	05/18/2023	1297	TEACHERS DISCOVERY	10.0.1100.410.23.0000.03	Excavation Kit	\$329.45
7400027748	05/18/2023	1297	TEACHERS DISCOVERY	10.0.1100.439.00.0000.03	Verb Slap! er/ir verbs	\$32.99
7400027748	05/18/2023	1297	TEACHERS DISCOVERY	10.0.1100.439.00.0000.03	Verbo Preterite	\$32.99
7400027748	05/18/2023	1297	TEACHERS DISCOVERY	10.0.1100.439.00.0000.03	Stickers	\$11.99
7400027748	05/18/2023	1297	TEACHERS DISCOVERY	10.0.1100.439.00.0000.03	Flangoo	\$169.00
7400027748	05/18/2023	1297	TEACHERS DISCOVERY	10.0.1100.439.00.0000.03	Magnetic Spinners	\$29.99
7400027748	05/18/2023	1297	TEACHERS DISCOVERY	10.0.1100.439.00.0000.03	Sample pack stickers	\$13.99
7400027748	05/18/2023	1297	TEACHERS DISCOVERY	10.0.1100.439.00.0000.03	Who Preterite Poster	\$23.00
7400027748	05/18/2023	1297	TEACHERS DISCOVERY	10.0.1100.439.00.0000.03	SHIPPING	\$14.99
Check Total:						\$1,090.47
NCB	05/01/2023	1287	TEACHERS RETIREMENT SYSTEM	10.3.0499.100.10.0000.00	TEACHERS PENSION	\$400.00
NCB	05/15/2023	1299	TEACHERS RETIREMENT SYSTEM	10.3.0499.100.10.0000.00	TEACHERS PENSION	\$400.00
Check Total:						\$800.00
7400027749	05/18/2023	1297	TENNANT SALES AND SERVICE COMPANY	20.0.2540.700.00.0000.03	BUMPER/HEAD/LABOR	\$573.22

Lincolnwood School District 74

Disbursement Detail Listing

Bank Name: COLE TAYLOR BANK - ACCOUNTS PAYABLE Date Range: 05/01/2023 - 05/31/2023 Sort By: Vendor
 Voucher Range: - Dollar Limit: \$0.00

Fiscal Year: 2022-2023

Print Employee Vendor Names Exclude Voided Checks Exclude Manual Checks Include Non Check Batches

Check Number	Date	Voucher	Payee	Account	Description	Amount	
7400027749	05/18/2023	1297	TENNANT SALES AND SERVICE COMPANY	20.0.2540.416.00.0000.03	BAG, VACUU, PAPER	\$18.50	
						Check Total:	\$591.72
7400027750	05/18/2023	1297	THE COVE SCHOOL	10.0.4120.670.35.0000.00	TUITION	\$5,745.78	
						Check Total:	\$5,745.78
7400027694	05/04/2023	1273	THE DBQ PROJECT	10.0.1100.410.23.0000.03	New Mini Q in American History	\$424.00	
						Check Total:	\$424.00
NCB	05/10/2023	1282	THE FAUCET SHOPPE	20.0.2540.400.00.0000.02	PLUMBING PARTS	\$135.39	
						Check Total:	\$135.39
7400027751	05/18/2023	1297	THE UNIVERSITY OF IOWA	10.0.2630.300.00.0000.00	CAHILL SCHOLARSHIP/NOAH	\$500.00	
						Check Total:	\$500.00
7400027695	05/04/2023	1273	THE VILLAGE OF LINCOLNWOOD-1	20.0.2540.370.00.0000.00	WATER	\$454.75	
7400027695	05/04/2023	1273	THE VILLAGE OF LINCOLNWOOD-1	20.0.2540.370.00.0000.00	WATER	\$612.70	
7400027695	05/04/2023	1273	THE VILLAGE OF LINCOLNWOOD-1	20.0.2540.370.00.0000.00	WATER	\$86.20	
7400027695	05/04/2023	1273	THE VILLAGE OF LINCOLNWOOD-1	20.0.2540.370.00.0000.00	WATER	\$12.49	
7400027695	05/04/2023	1273	THE VILLAGE OF LINCOLNWOOD-1	20.0.2540.370.00.0000.00	WATER	\$338.92	
						Check Total:	\$1,505.06
NCB	05/10/2023	1282	THERAPRO INC	10.0.2210.400.00.0000.02	RAISED LINE PAPER ASSORTMENT	\$23.49	
NCB	05/10/2023	1282	TRACERS	10.0.2310.300.00.0000.00	RESIDENCY	\$39.00	
NCB	05/10/2023	1282	TREERING CORPORATION	10.0.1100.450.60.0000.02	RUTLEDGE HALL	\$42.15	
NCB	05/10/2023	1282	U.S. POSTAL SERVICE	20.0.2540.400.00.0000.03	BIZ OFFICE BUNDLE	\$9.65	
						Check Total:	\$114.29
7400027696	05/04/2023	1273	ULINE	20.0.2540.416.00.0000.02	DISINFECTANT 32oz bottles	\$86.20	
7400027696	05/04/2023	1273	ULINE	20.0.2540.416.00.0000.02	Clorox Bleach 121 oz bottles	\$99.67	
7400027696	05/04/2023	1273	ULINE	20.0.2540.416.00.0000.02	Gloves Powder Free XL	\$203.53	

Lincolnwood School District 74

Disbursement Detail Listing

Bank Name: COLE TAYLOR BANK - ACCOUNTS PAYABLE Date Range: 05/01/2023 - 05/31/2023 Sort By: Vendor
 Voucher Range: - Dollar Limit: \$0.00

Fiscal Year: 2022-2023

Print Employee Vendor Names Exclude Voided Checks Exclude Manual Checks Include Non Check Batches

Check Number	Date	Voucher	Payee	Account	Description	Amount
7400027696	05/04/2023	1273	ULINE	20.0.2540.416.00.0000.02	Scrubbing Songe #74 (20)	\$251.43
7400027696	05/04/2023	1273	ULINE	20.0.2540.416.00.0000.04	Industrial Plunger	\$194.53
7400027696	05/04/2023	1273	ULINE	20.0.2540.416.00.0000.01	Dust Mop Handle	\$168.49
7400027696	05/04/2023	1273	ULINE	20.0.2540.416.00.0000.01	Powder Free Gloves Medium	\$895.11
7400027696	05/04/2023	1273	ULINE	20.0.2540.416.00.0000.01	Brooms Standard	\$136.90
7400027696	05/04/2023	1273	ULINE	20.0.2540.416.00.0000.04	Down Dish Soap 38oz	\$55.63
Check Total:						\$2,091.49
7400027752	05/18/2023	1297	UNIVERSITY OF ILLINOIS AT CHICAGO	10.0.2630.300.00.0000.00	CAHILL SCHOLARSHIP AWARD/HEBA	\$500.00
Check Total:						\$500.00
NCB	05/12/2023	1295	VALIC	10.3.0499.500.00.0000.00	ANNUITIES PAYABLE	\$937.50
NCB	05/12/2023	1295	VALIC	10.3.0499.500.00.0000.00	ANNUITIES PAYABLE	\$50.00
NCB	05/12/2023	1295	VALIC	20.3.0499.500.00.0000.00	ANNUITIES PAYABLE	\$50.00
NCB	05/12/2023	1295	VALIC	10.3.0499.500.00.0000.00	ANNUITIES PAYABLE	\$987.50
Check Total:						\$2,025.00
7400027697	05/04/2023	1273	VERITIV OPERATING COMPANY-1	10.0.1100.404.00.0000.01	8 1/2X11 10M 20# White Comet Multipurpose Pefc	\$952.00
7400027697	05/04/2023	1273	VERITIV OPERATING COMPANY-1	10.0.1100.404.00.0000.01	FUEL OR ENERGY	\$10.50
Check Total:						\$962.50
7400027753	05/18/2023	1297	VEX ROBOTICS, INC.	10.0.1100.450.48.0000.03	V5 Robot Battery Li-Ion 1100mAh	\$1,830.07
7400027753	05/18/2023	1297	VEX ROBOTICS, INC.	10.0.1100.450.48.0000.03	V5 Power Cable Assortment	\$241.53
Check Total:						\$2,071.60
7400027703	05/12/2023	1291	VISION SERVICE PLAN	10.3.0499.604.00.0000.00	EMPLOYEE BENEFIT- VISION	\$206.46
7400027703	05/12/2023	1291	VISION SERVICE PLAN	20.3.0499.604.00.0000.00	EMPLOYEE BENEFIT- VISION	\$22.94
7400027703	05/12/2023	1291	VISION SERVICE PLAN	10.3.0499.604.00.0000.00	EMPLOYEE BENEFIT- VISION	\$45.88
7400027703	05/12/2023	1291	VISION SERVICE PLAN	10.3.0499.604.00.0000.00	EMPLOYEE BENEFIT- VISION	\$206.46
7400027703	05/12/2023	1291	VISION SERVICE PLAN	20.3.0499.604.00.0000.00	EMPLOYEE BENEFIT- VISION	\$22.94
Check Total:						\$504.68
NCB	05/10/2023	1282	WALMART	10.0.1125.493.09.0000.01	OVERCHARGED FOR TIP	(\$18.14)
NCB	05/10/2023	1282	WALMART	10.0.1125.493.09.0000.01	PRE-K SNACKS	\$213.10

Lincolnwood School District 74

Disbursement Detail Listing

Bank Name: COLE TAYLOR BANK - ACCOUNTS PAYABLE Date Range: 05/01/2023 - 05/31/2023 Sort By: Vendor
 Voucher Range: - Dollar Limit: \$0.00

Fiscal Year: 2022-2023

Print Employee Vendor Names Exclude Voided Checks Exclude Manual Checks Include Non Check Batches

Check Number	Date	Voucher	Payee	Account	Description	Amount	
NCB	05/10/2023	1282	WALMART	10.0.1125.493.09.0000.01	TEDDY GRAHAMS HONEY	\$21.00	
NCB	05/10/2023	1282	WALMART	10.0.1100.423.36.0000.03	ITALIAN BREAD LOAF/MILK/HASH BROWNS	\$122.14	
NCB	05/10/2023	1282	WALMART	10.0.1100.450.57.0000.03	EGGS	\$17.79	
						Check Total:	\$355.89
7400027754	05/18/2023	1297	WALTER F. TENER	10.0.1100.338.42.0000.03	SOCCER OFFICIAL/5/9/23	\$63.00	
						Check Total:	\$63.00
7400027698	05/04/2023	1273	WELLS FARGO VENDOR FINANCIAL SERV.,LLC	10.0.1100.325.00.0000.00	EQUIPMENT RENTAL	\$2,048.72	
						Check Total:	\$2,048.72
7400027699	05/04/2023	1273	WHITT LAW LLC	10.0.2310.318.00.0000.00	GENERAL BUSINESS FILE	\$16,335.00	
7400027699	05/04/2023	1273	WHITT LAW LLC	10.0.2310.318.00.0000.00	TAX RATE OBJECTIONS	\$270.00	
						Check Total:	\$16,605.00
NCB	05/10/2023	1282	XSTAMPER	10.0.2520.400.00.0000.00	COLOR PADS	\$10.73	
						Check Total:	\$10.73
7400027755	05/18/2023	1297	ZABIHA HALAL MEAT PROCESSORS	10.0.2560.410.00.0000.00	CRESCENT CHICKEN	\$1,615.20	
7400027755	05/18/2023	1297	ZABIHA HALAL MEAT PROCESSORS	10.0.2560.410.00.0000.00	BEEF PATTIES/BEEF FRANKS	\$1,052.00	
						Check Total:	\$2,667.20
						Bank Total:	\$1,150,632.32

Voided Checks

7400027665	05/04/2023	1273	FOLLETT SCHOOL SOLUTIONS, INC.-1	VOID	10.3.0431.000.00.0000.00	VOID: WRONG ADDRESS	\$528.08
						Check Total:	\$528.08
						Voided Checks Total:	\$528.08

Lincolnwood School District 74

Disbursement Detail Listing

Bank Name: COLE TAYLOR BANK - ACCOUNTS PAYABLE Date Range: 05/01/2023 - 05/31/2023 Sort By: Vendor
 Voucher Range: - Dollar Limit: \$0.00

Fiscal Year: 2022-2023

Print Employee Vendor Names
 Exclude Voided Checks
 Exclude Manual Checks
 Include Non Check Batches

Check Number	Date	Voucher	Payee	Account	Description	Amount
			<u>Fund</u>			<u>Amount</u>
			10			\$805,872.30
			20			\$124,445.13
			40			\$154,743.44
			60			\$65,571.45
			Fund Totals:			\$1,150,632.32

End of Report

Disbursements Grand Total: \$1,150,632.32