

## **District 23 Buildings & Sites Committee Meeting**

Tuesday, September 5, 2023 8:00 AM

Grodsky Administration Building, 700 N Schoenbeck Rd, Prospect Heights, IL  
60070

### **I. Call to Order**

### **II. Discussion Items**

II.A. Discussion of Summer 2023 Work

II.B. Ross/Sullivan/Grodsky - Replacement of  
Windows, Siding & Doors - Update on Bid Process

II.C. Window Shades - Discussion of Bid  
Timeline

II.D. Facilities & Finance Discussion of  
Potential 2024 Referendum Opportunities

II.E. PHYBS - Shed Request at Phantom's Field

II.F. MacArthur Plumbing Repair - Courtyard  
Area

II.G. Eagle Scout Project - Jason Prempas

II.H. 2023-24 School Maintenance Project Grant  
- Intent to Apply

### **III. Adjournment**





**SUMMER 2024 BUDGET / ESTIMATE (REV. 7/26/23)**

<b>WINDOW AND SIDING REPLACEMENT</b>			
<b>GRODSKY</b>			
SIDING	\$96,818		
WINDOWS	\$165,000		
MISC	\$75,000		
COST REDUCTION ITEMS	-\$138,442		
SUBTOTAL		\$336,818	
<b>SULLIVAN</b>			
SIDING	\$225,909		
WINDOWS	\$390,000		
MISC	\$75,000		
COST REDUCTION ITEMS	-\$96,215		
SUBTOTAL		\$690,909	
<b>ROSS</b>			
SIDING	\$193,636		
WINDOWS	\$355,000		
MISC	\$75,000		
COST REDUCTION ITEMS	-\$26,413		
SUBTOTAL		\$623,636	
<b>SUBTOTAL</b>		<b>\$1,416,707</b>	
5% DESIGN CONTINGENCY		\$70,835	
5% CONST. CONTINGENCY		\$70,835	
GC FEES, OH&P		\$233,757	
<b>ANTICIPATED BID VALUE</b>		<b>\$1,792,135</b>	
A/E FEES		\$138,890	
<b>WINDOW TREATMENTS</b>			
GRODSKY			
SULLIVAN			
ROSS			
SUBTOTAL			
<b>SUBTOTAL</b>		<b>\$75,000</b>	
<b>SECURITY CAMERAS</b>			
CAMERAS		\$200,000	
SUBTOTAL			
<b>SUBTOTAL</b>		<b>\$200,000</b>	
<b>ALL-IN TOTAL</b>		<b>\$2,206,025</b>	



**ALTERNATE BID LIST**

<b>SULLIVAN</b>	EST. VALUE	
ENTRANCE CANOPY	\$48,197	
DOOR/HARDWARE REPLACEMENT	\$25,553	
SOFFITS (NORTH CANOPY ONLY)	\$4,478	
<b>SULLIVAN SUBTOTAL</b>		<b>\$78,228</b>

<b>ROSS</b>	EST. VALUE	
ENTRANCE CANOPY	\$68,221	
DOOR/HARDWARE REPLACEMENT	\$39,987	
SOFFITS (SHEET METAL)	\$19,898	
<b>ROSS SUBTOTAL</b>		<b>\$128,107</b>

<b>GRODSKY</b>	EST. VALUE	
EXTERIOR DOOR REPLACEMENT	\$14,864	
<b>GRODSKY SUBTOTAL</b>		<b>\$14,864</b>

<b>ALTERNATE BIDS TOTAL</b>	<b>\$221,198</b>
A/E FEE FOR ALL ALTERNATES (IF NONE AWARDED)	\$13,714
A/E FEE FOR ALL ALTERNATES (IF ALL AWARDED)	\$17,143

<b>GRAND TOTAL ALL-IN (NO ALTS. W/SECURITY &amp; SHADES)</b>	<b>\$2,219,739</b>
<b>GRAND TOTAL ALL-IN (W/ALL ALTS., SECURITY &amp; SHADES)</b>	<b>\$2,444,366</b>



**MASTER BUDGET / ESTIMATE (REV. 7/26/23)**

<b>WINDOW AND SIDING REPLACEMENT</b>		<b>EST. DATED</b>	<b>EST. DATED</b>	<b>BD. MTG.</b>	<b>N-A ORIG.</b>	
<b>GRODSKY, SULLIVAN, ROSS, MACARTHUR</b>		<b>7/18/2023</b>	<b>5/17/2023</b>	<b>10/12/2022</b>	<b>BUDGET</b>	
GRODSKY	\$336,818	\$336,818	\$422,081	\$466,735		
SULLIVAN	\$690,909	\$690,909	\$646,409	\$913,325		
ROSS	\$623,636	\$623,636	\$651,162	\$1,066,253		
MACARTHUR (2025 COST)	\$1,204,834	\$1,204,834	\$1,303,430	\$1,440,712		
<b>SUBTOTAL</b>	<b>\$2,856,198</b>	<b>\$2,856,198</b>	<b>\$3,023,082</b>	<b>\$3,887,025</b>	<b>\$2,784,680</b>	
<b>COST REDUCTION OPTIONS</b>						
HARDIE BOARD IN LIEU OF NICHIA	-\$86,103					
REPAIR SULLIVAN CLERESTORY WINDOW	-\$34,650					
ALTERNATE DESIGN AT GRODSKY	-\$125,856					
BRICK IN LIEU OF GLASS BLOCK AT GRODSKY	\$0					
<b>SUBTOTAL</b>	<b>-\$246,609</b>	<b>\$0</b>				
DESIGN CONTINGENCY	\$130,479	\$142,810	\$151,154	\$388,703	\$0	
5% ADDL DESIGN CONTINGENCY (MAC ONLY)	\$60,242	\$60,242	\$65,172	\$0	\$0	
CONST. CONTINGENCY	\$130,479	\$142,810	\$151,154	\$388,703	\$150,000	
GC/CM FEES, OH&P	\$467,573	\$471,273	\$498,809	\$699,665	\$498,157	
<b>ANTICIPATED BASE BID VALUE</b>	<b>\$3,398,363</b>	<b>\$3,673,332</b>	<b>\$3,889,371</b>	<b>\$5,364,095</b>	<b>\$3,432,837</b>	
A/E FEES (N-A ORG. BASED ON COMBINED WITH EISENHOWER ADDITION)	\$263,373	\$284,683	\$301,426	\$415,717	\$212,764	
ENTRANCE CANOPIES			\$243,638			
<b>WINDOW TREATMENTS (BY OWNER)</b>						
GRODSKY			\$56,000			
SULLIVAN			\$112,850			
ROSS			\$119,400			
MACARTHUR			\$160,700			
SUBTOTAL			\$448,950			
CONTINGENCY (20%)			\$89,790			
<b>SUBTOTAL</b>	<b>\$75,000</b>	<b>\$75,000</b>	<b>\$538,740</b>	<b>N/A</b>	<b>N/A</b>	
<b>SECURITY CAMERAS (BY OWNER)</b>						
CAMERAS	\$200,000					
<b>SUBTOTAL</b>	<b>\$200,000</b>	<b>\$200,000</b>	<b>N/A</b>			
<b>SUBTOTAL (ALL IN)</b>		<b>\$3,661,736</b>	<b>\$3,958,015</b>	<b>\$4,190,797</b>	<b>\$5,779,812</b>	<b>\$3,645,601</b>
<b>SUBTOTAL ALL-IN WITH CAMERAS</b>		<b>\$3,861,736</b>	<b>\$4,158,015</b>	<b>\$4,390,797</b>	<b>\$5,564,095</b>	<b>\$3,845,601</b>
<b>SUBTOTAL ALL-IN W/SHADES &amp; CAMERAS</b>		<b>\$3,936,736</b>	<b>\$4,233,015</b>	<b>\$5,173,175</b>	<b>\$6,318,552</b>	<b>\$4,384,341</b>



**ALTERNATE BID LIST**

<b>MACARTHUR</b>		EST. VALUE
ENTRANCE CANOPY		\$114,102
<b>MACARTHUR SUBTOTAL</b>		<b>\$114,102</b>

<b>SULLIVAN</b>		EST. VALUE
ENTRANCE CANOPY		\$68,221
DOOR/HARDWARE REPLACEMENT		\$25,553
SOFFITS (NORTH CANOPY ONLY)		\$4,478
<b>SULLIVAN SUBTOTAL</b>		<b>\$98,253</b>

<b>ROSS</b>		EST. VALUE
ENTRANCE CANOPY		\$68,221
DOOR/HARDWARE REPLACEMENT		\$39,987
SOFFITS (SHEET METAL)		\$8,855
<b>ROSS SUBTOTAL</b>		<b>\$117,063</b>

<b>GRODSKY</b>		EST. VALUE
EXTERIOR DOOR REPLACEMENT		\$14,864
<b>GRODSKY SUBTOTAL</b>		<b>\$14,864</b>

<b>ALTERNATE BIDS TOTAL</b>	<b>\$344,281</b>
A/E FEE FOR ALL ALTERNATES (IF NONE AWARDED)	\$21,345
A/E FEE FOR ALL ALTERNATES (IF ALL AWARDED)	\$26,682

**ALL-IN GRAND TOTALS**

<b>WITH REDUCTIONS, NO ALTERNATES</b>	<b>\$3,683,081</b>
<b>WITH CAMERAS, REDUCTIONS, NO ALTERNATES</b>	<b>\$3,883,081</b>
<b>WITH CAMERAS, SHADES, REDUCTIONS, NO ALTERNATES</b>	<b>\$3,958,081</b>



## WINDOW TREATMENTS

### General Notes:

1. Window sizes provided are frame sizes.
2. Clerestory windows (8'-8" x 4'-0") are manually operated to match current existing conditions. Longer chains may be required for operation.
3. No window treatments included for interior borrowed lights.
4. No window treatments provided at doors with transoms and/or sidelights.
5. Window treatments at Ross (24'-8" x 1'-9" & 8'-7" x 1'-9") are transoms and may need longer chains for operation.
6. Interior finishes vary - cmu, gypsum board, plaster, brick.
7. Window treatments for Sullivan Library and Grodsky Basement are not included.
8. Macarthur windows (2'-8" x 7'-0") have larger masonry openings with metal insulated panel transoms at top and bottom. Top transom 2'-0" ht. Bottom panel 2'-4" ht. Overall opening height 11'-0"
9. SD23 will select fabric type and shade style.

### GRODSKY

	WIDTH	HEIGHT	QTY
FIRST FLOOR			
	11'-4"	9'-2"	8
	1'-4"	3'-0"	2
SECOND FLOOR			
	3'-4"	5'-4"	3

ROOMS NOT INCLUDED: BASEMENT

### ROSS

	WIDTH	HEIGHT	QTY
SOUTH ELEV.			
	5'-0"	5'-2"	2
NORTH ELEV.			
	4'-8"	4'-0"	1
WEST ELEV.			
	9'-4"	5'-2"	1
	5'-0"	5'-0"	1
	5'-0"	5'-2"	14
	2'-8"	5'-2"	1
EAST ELEV.			
	5'-0"	5'-2"	14
	7'-3"	4'-10"	1
	24'-8"	1'-9"	1
	9'-6"	6'-8"	1
	5'-0"	6'-8"	1
	8'-7"	1'-9"	1
	5'-0"	4'-8"	6

ROOMS NOT INCLUDED: 216-222, 303, 003



## WINDOW TREATMENTS

### SULLIVAN

	WIDTH	HEIGHT	QTY
SOUTH ELEV.			
	5'-0"	5'-10"	4
	8'-8"	4'-0"	3
NORTH ELEV.			
	5'-10"	5'-0"	2
	8'-8"	4'-0"	3
	7'-0"	4'-0"	1
WEST ELEV.			
	5'-3"	4'-0"	1
	5'-0"	5'-0"	17
	2'-0"	5'-0"	2
	3'-0"	4'-0"	1
EAST ELEV.			
	5'-0"	5'-0"	14

ROOMS NOT INCLUDED: 139, 107, CO3

### MACARTHUR

	WIDTH	HEIGHT	QTY
SOUTH ELEV.			
	5'-4"	5'-0"	3
	3'-0"	5'-4"	7
	2'-8"	7'-0"	19
NORTH ELEV.			
	2'-8"	7'-0"	6
	6'-8"	6'-8"	1
	2'-8"	6'-8"	2
	3'-0"	5'-4"	8
	23'-10"	2'-2"	1
	6'-8"	4'-8"	4
	2'-9"	5'-0"	16
	5'-4"	5'-0"	5
WEST ELEV.			
	5'-3"	4'-0"	1
	5'-0"	5'-0"	17
	2'-0"	5'-0"	2
	3'-0"	4'-0"	1
EAST ELEV.			
	2'-8"	7'-0"	4
	4'-8"	2'-6"	2
	3'-0"	5'-4"	16



**JUST RITE ACOUSTICS, INC.**

1501 Estes Avenue • Elk Grove Village, IL 60007 • p 847.357.8200 • f 847.357.8280

Date: 7/3/2023  
To: School District 23

From: Sam Gebelhoff  
847-434-0732  
sg@jrausa.com  
www.justriteacoustics.com

Attn: Amy McPartlin  
Project: Prospect Heights SD23  
NA  
Prospect Heights, IL

**JRA Products and Services**  
**Acoustical Ceilings**  
**Acoustical Wall Panels**  
**Site Built Acoustical Wall Panels**  
**ASM Access Flooring**  
**Roller Shades and Window Treatments**

<i>Work Figured</i>	<i>Date of Drawings</i>	<i>Per Drawings</i>	<i>Addendums Included</i>
Window Treatment	NA	NA	
<b>Materials To Be As Follows</b>			
Type #1:	Draper: Flexshade NEXD - Single Manual Roller Shade With Fascia Fabric: Phifer SW Basic, 3% Openness, 6 Standard Colors		
	Accessories: Fascia - Standard, Square, White		
Clarifications:	Tax is Excluded Figured as Below Ceiling Mounted With Front Fascia - <b>No Shade Pocket Figured</b> 253 Total Shade Bands This is a Furnish and Install price based on union straight time rates Lead Time is 4 to 6 weeks after Submittal Approvals and Field Measuring <b>Backing /Blocking Required - Backing / Blocking by Others</b> <b>For Budgeting Purposes ONLY</b>		
Price:	<b>\$74,600.00</b>		

Outdoors / Sheds & Outdoor Storage / Sheds / Wood Storage Sheds

### Heartland Statesman 10-ft x 16-ft Wood Storage Shed (Floor Included)

Item #323874 Model #191404

Shop Heartland ★★★★☆ 566

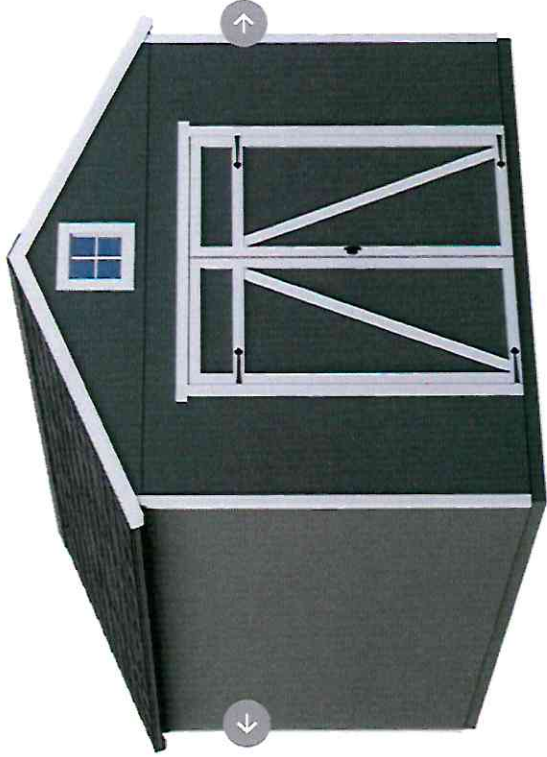

**\$2,862.90**

~~\$3,181.00~~  
Save **\$318.10**  
Ends Sep 27

**\$2719.76** when you choose 5% savings on eligible purchases every day. [Learn how](#) OR **\$120/mo** suggested payments with 24 month special financing. Lid lime. [Learn how](#)

18 monthly installments of \$177.26 with Lowe's Pay [Learn How](#)

- Pre-cut kit, nothing to saw
- 7-ft tall side wall height fits rakes, shovels, ladders and more
- Bonus features include complete floor system, storage loft, two shelves and a gable window

Common Exterior Size (W x L)  
**10-ft x 16-ft**

**Pickup**  
Ready by Thu, Sep 21 (Est)

**Delivery**  
As soon as Fri, Sep 22

FREE Pickup at Wicker Park Lowe's

- 1 +

**Add to Cart**

**Get It Installed**

Shingles and paint sold separately. In-use/lifestyle images, window, loft, shelves, vents included

Proposed shed to be professionally installed by the PHYBS on Phantom Field on south side behind dugout. This would be used to hold an electric lawnmower to cut our infield grass along with a pitching mound and related baseball equipment. This would be set on cemented pilons per the PH code. This is a significant increase in size from the original 8" x 8" request.

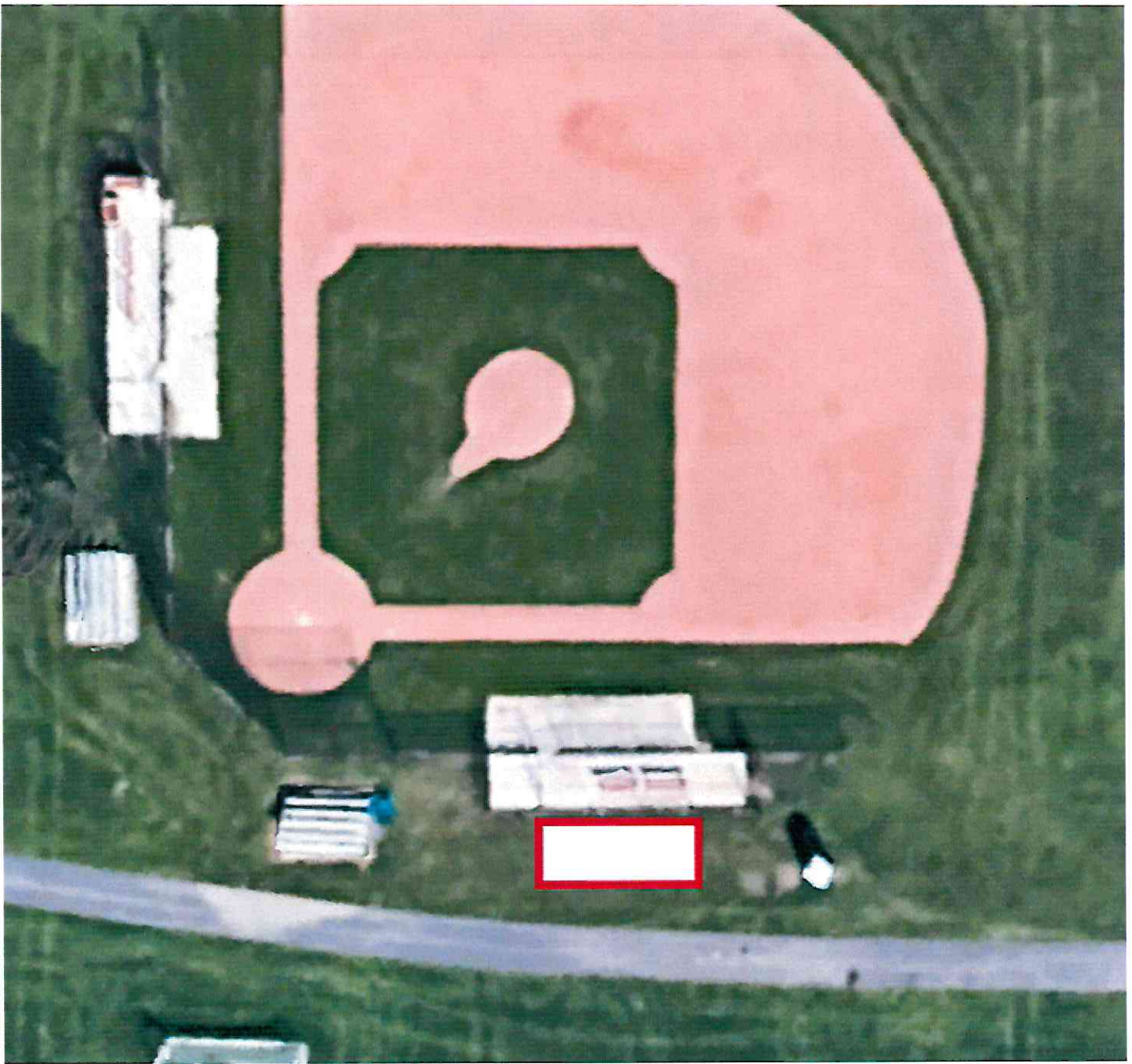

**16917**  
**PART 1**



***Call Us First!***  
***DO NOT RETURN TO STORE.***

For questions on assembly or for general inquiries, you may contact us in the following ways:  
Call customer service: **1-877-743-3400**

---

## ***AVOID THE WAIT!***

visit us online at  
**help.backyardproducts.com**

- Submit a help request
- Answers to frequently asked questions
- Live chat with an agent



Did you enjoy building your shed?

**JOIN OUR TEAM**  
AND MAKE UP TO \$1,500/WEEK\*

***Call a Recruiter Today! 734-365-7000***



Flexible schedule



No selling,  
just building



Bonus incentives  
available



\*based on number of completed installations



# Win \$500

A new winner is selected every 2 months.

Review your product for the chance to win a **\$500 Visa Gift Card**.



## How to Enter:

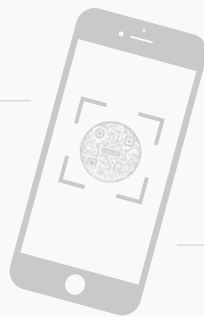

Open camera.  
Aim. Tap.



**1**

**Scan**  
QR code above.

**2**

**Click**  
'write a review'

**3**

**Find your product.**  
Tell us what you think.

**4**

**Submit your review.**  
You'll be notified by e-mail if  
you've won the \$500 gift card.

Write a Backyard Products, LLC. product review at [backyardreviews.net](https://backyardreviews.net) for a chance to win a \$500 Visa gift card. No purchase necessary to enter. Must be legal U.S. resident (including DC & Puerto Rico), 18 or older to participate. Taxes on prize are responsibility of winner. Odds of winning depend on the number of eligible reviews received. Void where prohibited. For complete details and official rules, visit <https://backyardreviews.net/sweepstakes-rules>.

# ASSEMBLY MANUAL

## CLASSIC 12' x 12' (365,8 x 365,8 cm)

# PART 1

	BUILDING SIZE	ACTUAL FLOOR SIZE
BASE MODEL	12' x 12' (365,8 x 365,8 cm)	12' x 12' (365,8 x 365,8 cm)
+1: 12' x 4' Extender	12' x 16' (365,8 x 487,7 cm)	12' x 16' (365,8 x 487,7 cm)
+1: 12' x 8' Extender	12' x 20' (365,8 x 609,6 cm)	12' x 20' (365,8 x 609,6 cm)
+1: 12' x 8' and +1: 12' x 4' Extender	12' x 24' (365,8 x 731,5 cm)	12' x 24' (365,8 x 731,5 cm)

KEEP THIS MANUAL FOR FUTURE REFERENCE

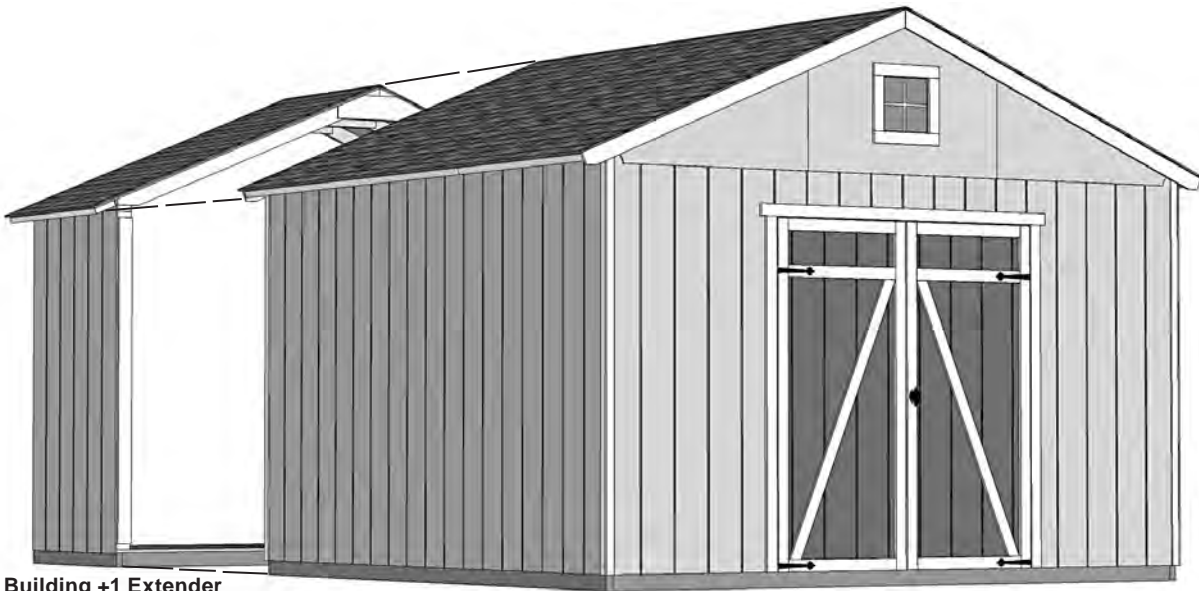

Base Building +1 Extender  
12' x 16'

Base Building 12' x 12'

### ⚠ **IMPORTANT!** ⚠

READ INSTRUCTIONS THOROUGHLY PRIOR TO BEGINNING ASSEMBLY.

### **BEFORE YOU BEGIN**

#### • BUILDING RESTRICTIONS AND APPROVALS

Be sure to check local building department and homeowners association for specific restrictions and/ or requirements before building.

#### • ENGINEERED DRAWINGS

Contact our Customer Service Team if engineered drawings are needed to pull local permits.

#### • SURFACE PREPARATION

To ensure proper assembly you must build your shed on a level surface.

Recommended methods and materials to level your shed are listed on page 10.

#### • CHECK ALL PARTS

Inventory all parts listed on pages 5-8.

#### • ADDITIONAL MATERIALS

You will need additional materials to complete your shed. See pages 3-4 for required and optional materials and quantities.









**\*\*\*CONTACT OUR CUSTOMER SERVICE TEAM  
IF ANY PARTS ARE MISSING OR DAMAGED\*\*\***

**- Order form and warranty at back of manual -**

**Call: 1-877-743-3400 email: customerservice@backyardproductsllc.com**



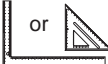



# TOOLS

## Required

- Phillips Screwdriver 
- Drill / Driver 
  - 3/8" Drill Bit
  - #2 Philips Drive Bit
- Hammer 
- Level 
- Pencil 
- Tape Measure 
- Square  or 

- Utility Knife 
  - Shingle Blades 
- Caulk Gun 
- Paint Tools 
- Safety Glasses 
- Ladder 

## Optional

- Tool Belt/ Nail Pouch 
- Tin Snips (for drip edge) 
- Chalk Line 
- Nail Gun 
  - gun nails
- Gloves 
- Sawsall 

Safety! Always use approved safety glasses during assembly.

## HELPFUL REMINDER SYMBOLS

Look for these symbols for helpful reminders throughout this manual.



= Assistance Required; two or more people.



= Ensure squareness.



= Important required step or operation.



= Helpful assembly hint.



= Mark part with pencil.



**BEGIN** = Beginning of steps for assembly or installation.



**FINISH** = You have finished the assembly or installation.



= Level

## ORIENT LUMBER AND TRIM FOR BEST APPEARANCE

Framing lumber is graded for structural strength and not appearance. Exterior trim is graded for one good side.

Always install the material leaving the best edge and best surface visible. Please remember that these blemishes in no way negatively affect the strength or integrity of our product. (See Fig. A, B, C.)

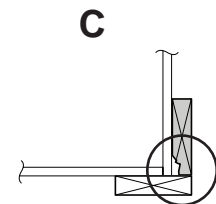
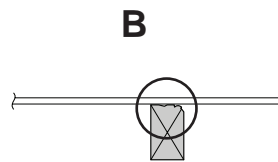
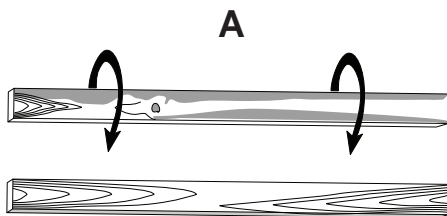

## ADDITIONAL MATERIALS

### FOUNDATION OR FLOOR MATERIALS

- If you purchased a separate floor kit, use instructions and materials in that kit to construct your floor.
- See the FLOOR LEVELING section on page 10 for recommended methods and suggested materials to properly level your floor, as this will vary depending on your specific site.

### REINFORCED WOOD FLOOR FRAME (OPTIONAL)

IMPORTANT! Depending on your specific use you may want to construct a heavy duty floor frame by adding additional floor joists (shown below as shaded). Below is a list of additional materials (not included):

#### 12x12'

- x3** 2 x 4 x 12' (5,1 x 10,2 x 304,8 cm) Treated Lumber cut to 2 x 4 x 117" (5,1 x 10,2 x 297,2 cm)
- x12** 3" (7,6 cm) hot-dipped galvanized nails

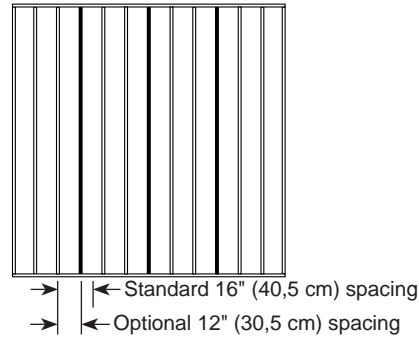

#### 12x16'

- x4** 2 x 4 x 12' (5,1 x 10,2 x 304,8 cm) Treated Lumber cut to 2 x 4 x 117" (5,1 x 10,2 x 297,2 cm)
- x16** 3" (7,6 cm) hot-dipped galvanized nails

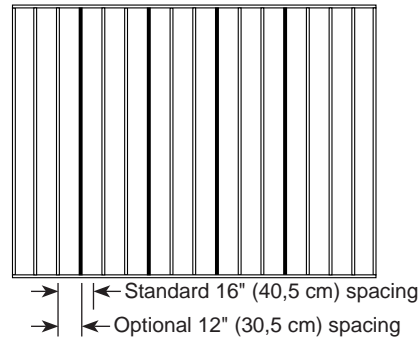

#### 12x20'

- x5** 2 x 4 x 12' (5,1 x 10,2 x 304,8 cm) Treated Lumber cut to 2 x 4 x 117" (5,1 x 10,2 x 297,2 cm)
- x20** 3" (7,6 cm) hot-dipped galvanized nails

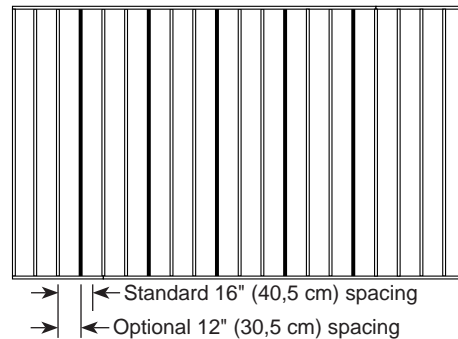

#### 12x24'

- x6** 2 x 4 x 12' (5,1 x 10,2 x 304,8 cm) Treated Lumber cut to 2 x 4 x 117" (5,1 x 10,2 x 297,2 cm)
- x24** 3" (7,6 cm) hot-dipped galvanized nails

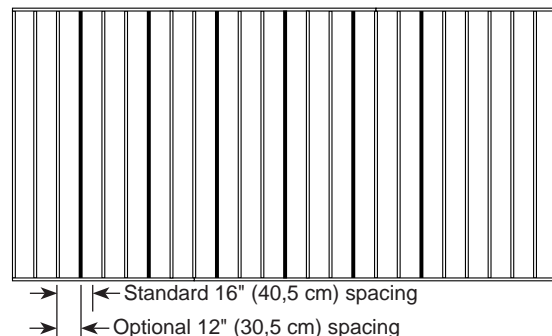

# ADDITIONAL MATERIALS

## COMPLETING YOUR SHED

You will need these additional materials:

	12x12'	12x16'	12x20'	12x24'		12x12'	12x16'	12x20'	12x24'
<input type="checkbox"/> <b>3-TAB SHINGLES (Bundles)</b> .....	7	9	11	13	<input type="checkbox"/> <b>Paint for trim/Quart</b> Use 100% acrylic latex exterior paint.	2	2	3	3
<input type="checkbox"/> <b>PAINT FOR SIDING (Gallons)</b> ..... Use 100% acrylic latex exterior paint. (2) coats recommended.	3	3	4	4	<input type="checkbox"/> <b>Caulk Tubes</b> ..... Use acrylic paintable latex exterior caulk.	4	5	6	7
<input type="checkbox"/> <b>1" galvanized roofing nails (lbs).</b> For shingles.	4	5	6	7					

## OPTIONAL MATERIALS

	12x12'	12x16'	12x20'	12x24'
<input type="checkbox"/> <b>Drip Edge (Feet)</b> .....	60	70	80	90
<input type="checkbox"/> <b>#15 Roofing Felt (Sq ft. to cover)</b> ....	199	264	329	399
<input type="checkbox"/> <b>1" Galvanized Roofing Nails (lbs)</b> .... For roofing felt.	1	1.5	2	2.5

REFER TO THE BACK OF THIS MANUAL AND THE MANUFACTURER'S INSTRUCTIONS FOR INSTALLATION OF SHINGLES, DRIP EDGE AND FELT.

# PARTS IDENTIFICATION AND SIZES

Double letter part identification is stamped on some parts.

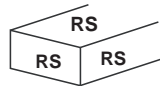

• Check these locations for part stamp.

## WOOD SIZE CONVERSION CHART

Nominal Board Size	Actual Size
2 x 4 .....	1-1/2" x 3-1/2" (3,8 x 8,9 cm)
1 x 4 .....	3/4" x 3-1/2" (1,9 x 8,9 cm)
2 x 3 .....	1-1/2" x 2-1/2" (3,8 x 6,3 cm)
1 x 3 .....	3/4" x 2-1/2" (3,8 x 6,3 cm)

12x12'



## GABLE 12' x 12' PARTS LIST

INVENTORY YOUR PARTS before you begin.

We suggest sorting parts by the category they are listed in.

x1 **GAA** 1 x 3 x 5" (2,5 x 7,6 x 12,7 cm)  
Used as a gauge block for 3/4" (1,9 cm) measurement.

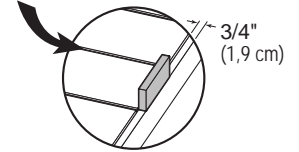

### WALL

- x5 **AL** 2 x 4 x 7" (5,1 x 10,2 x 17,8 cm)
- x4 **AF** 2 x 4 x 18-1/8" (5,1 x 10,2 x 46 cm)
- x4 **HVC** 2 x 4 x 44-3/8" (5,1 x 10,2 x 112,7 cm)
- x6 **SP** 2 x 4 x 48" (5,1 x 10,2 x 121,9 cm)
- x1 7/16" x 3-1/4" x 66-3/4" (1,1 x 8,3 x 170,2 cm) OSB
- x2 **AM** 2 x 4 x 67" (5,1 x 10,2 x 170,2 cm)
- x2 **UM** 2 x 4 x 68" (5,1 x 10,2 x 172,7 cm)
- x4 **YFA** 2 x 4 x 68-1/2" (5,1 x 10,2 x 174 cm)
- x23 **AI** 2 x 4 x 78-1/2" (5,1 x 10,2 x 199,4 cm)
- x4 **TJ** 2 x 4 x 92-5/8" (5,1 x 10,2 x 235,3 cm)
- x6 **TP** 2 x 4 x 96" (5,1 x 10,2 x 243,9 cm)

### RAFTERS

- x12 6 x 24" (15,2 x 61 cm)
- x14 **ADA** 2 x 4 x 77-15/16" (5,1 x 10,2 x 198 cm)
- x1 **TP** 2 x 4 x 96" (5,1 x 10,2 x 243,9 cm)

### TRIM

- x2 **DI** 19/32" x 2-1/2" x 12" (1,6 x 7,6 x 30,5 cm)
- x2 **EU** 19/32" x 2-1/2" x 17" (1,6 x 7,6 x 43,2 cm)
- x2 **WTC** 2 x 6 x 49-3/4" (5,1 x 15,2 x 126,4 cm)
- x2 **CQR** 19/32" x 3-1/2" x 84-15/16" (1,5 x 8,9 x 215,7 cm)
- x2 **CQL** 19/32" x 3-1/2" x 84-15/16" (1,5 x 8,9 x 215,7 cm)
- x8 3/8" x 1-3/4" x 83-1/2" (1 x 4,5 x 212,1 cm)
- x2 **VX** 2 x 6 x 96" (5,1 x 15,3 x 243,9 cm)

### DOORS

- x2 **AH** 19/32" x 2-1/2" x 26-5/8" (1,5 x 6,3 x 67,7 cm)
- x1 **AHR** 19/32" x 2-1/2" x 62" (1,5 x 6,3 x 157,5 cm)
- x1 **AHL** 19/32" x 2-1/2" x 62" (1,5 x 6,3 x 157,5 cm)
- x2 **OO** 69" (175,3 cm) Door Stiffener
- x1 **ZJ** 19/32" x 2-1/2" x 72" (1,5 x 6,3 x 182,9 cm)

## PANEL & DOORS PARTS LIST

NOTE: Panel parts are not stamped with part identification.

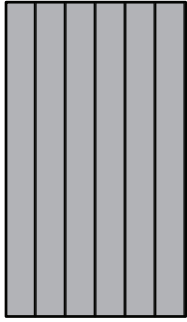

x9

3/8 x 48 x 84"  
(1 x 121,9 x 213,4 cm)

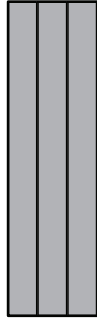

x2

3/8 x 23-7/8 x 84"  
(1 x 60,6 x 213,4 cm)

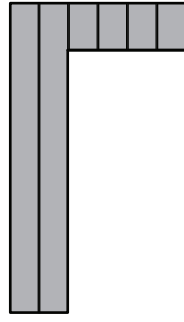

x1

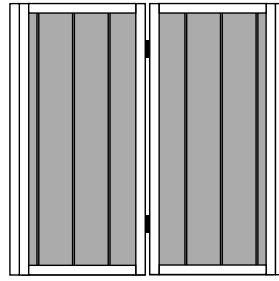

x1

x1

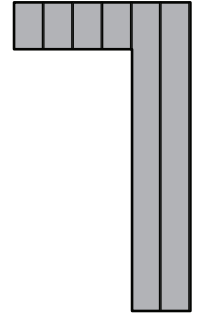

x1

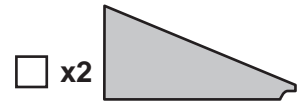
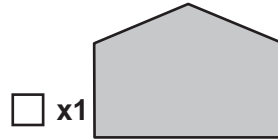
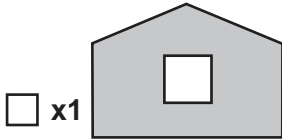

## ROOF PANELS

Roof panels are 7/16" (1,1 cm) thick.



48" x 96"  
(121,9 x 243,8 cm)

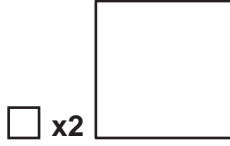

47-7/8" x 48"  
(121,6 x 121,9 cm)

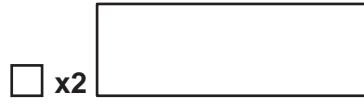

36-1/2" x 96"  
(92,7 x 243,8 cm)

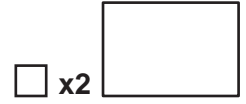

36-1/2" x 47-7/8"  
(92,7 x 121,6 cm)

## LOFT & SHELF PARTS LIST

Loft and shelf panels are 7/16" (1,1 cm) thick.

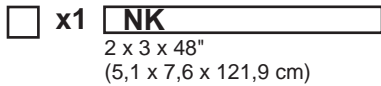

2 x 3 x 48"  
(5,1 x 7,6 x 121,9 cm)

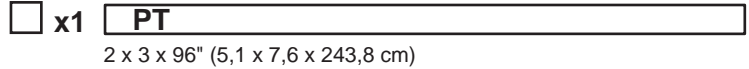

2 x 3 x 96" (5,1 x 7,6 x 243,8 cm)

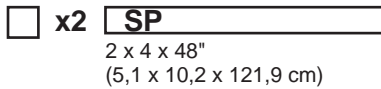

2 x 4 x 48"  
(5,1 x 10,2 x 121,9 cm)

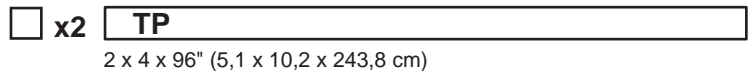

2 x 4 x 96" (5,1 x 10,2 x 243,8 cm)



23-7/8" x 40-7/8" (60,6 x 103,8 cm)

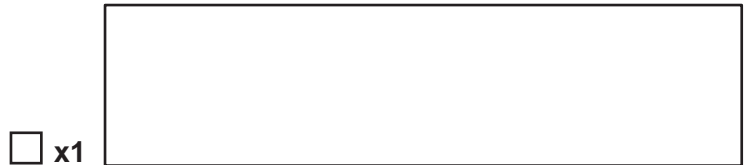

23-7/8" x 96" (60,6 x 243,8 cm)

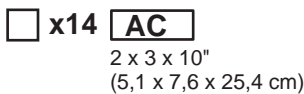

2 x 3 x 10"  
(5,1 x 7,6 x 25,4 cm)

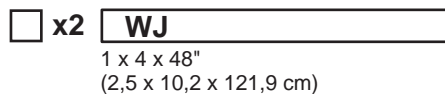

1 x 4 x 48"  
(2,5 x 10,2 x 121,9 cm)

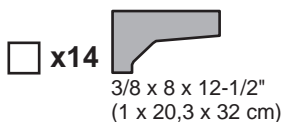

3/8 x 8 x 12-1/2"  
(1 x 20,3 x 32 cm)

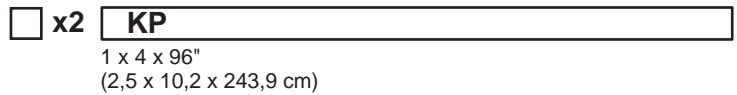

1 x 4 x 96"  
(2,5 x 10,2 x 243,9 cm)



7/16 x 11-7/8 x 48"  
(1,1 x 30,2 x 121,9 cm)

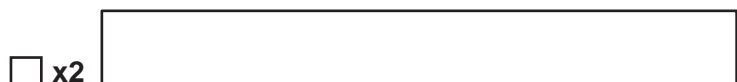



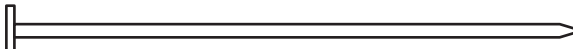
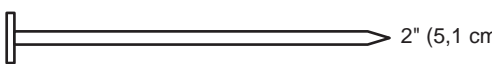

7/16 x 11-7/8 x 96"  
(1,1 x 30,2 x 243,9 cm)



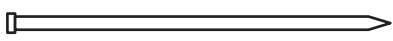

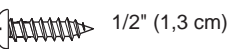
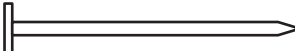

## NAIL BOXES (Shown Actual Size)

- x6 BOXES**  3" (7,6 cm)
- x6 BOXES**  2" (5,1 cm)

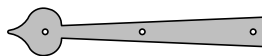
## FASTENER/HARDWARE BAG (Shown Actual Size)

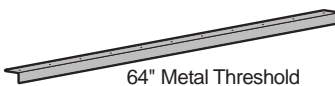
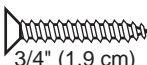
- x155**  2" (5,1 cm)
  - x90**  3" (7,6 cm)
  - x25**  2" (5,1 cm)
  - x70**  1-1/4" (3,2 cm)
  - x85**  3/4" (1,9 cm)
  - x12**  1/2" (1,3 cm)
  - x85**  1-1/2" (3,8 cm)
- NOTE:**  
*If you are using a nail gun, nails may be used where screws are shown for quicker assembly. Length of nail must match screw length.*

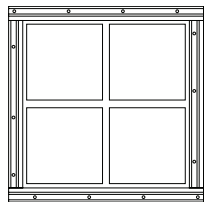
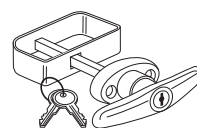
## Other HARDWARE (Not Actual Size)

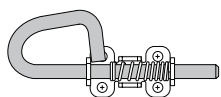
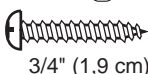
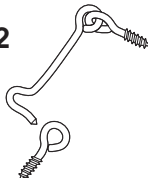
- x4** 
- x12**  3/4" (1,9 cm)
- x1**  64" Metal Threshold
- x11**  3/4" (1,9 cm) Bagged separately/  
special coating
- x2**  3/8" LOFT HDW. SET:  
5-1/2" Hex bolt,  
2 flat washers, lock nut
- x1**  Window
- x1** 
- x2**  1-1/2" (3,8 cm)
- x2** 
- x8**  3/4" (1,9 cm)
- x2** 

# GABLE EXTENDER KIT PARTS LIST

Inventory your parts before you begin.  
We suggest sorting parts by the category they are listed in.

Part identification is stamped on some parts.









• Check these locations for part stamp.



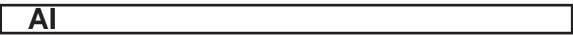

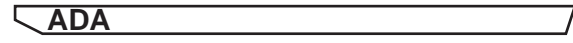
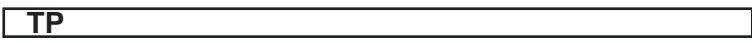

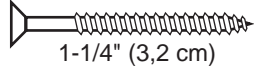
## WOOD SIZE CONVERSION CHART

Nominal Board Size	Actual Size
2 x 4	1-1/2" x 3-1/2" (3,8 x 8,9 cm)
1 x 4	3/4" x 3-1/2" (1,9 x 8,9 cm)
2 x 3	1-1/2" x 2-1/2" (3,8 x 6,3 cm)
1 x 3	3/4" x 2-1/2" (3,8 x 6,3 cm)

## 12' x 4' EXTENDER

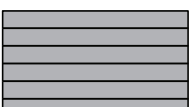
<b>WALL</b>	<input type="checkbox"/> x6 <b>SP</b>  2 x 4 x 48" (5,1 x 10,2 x 121,9 cm)	
	<input type="checkbox"/> x2 <b>VF</b>  2 x 6 x 48" (5,1 x 15,2 x 121,9 cm)	
	<input type="checkbox"/> x4 <b>AI</b>  2 x 4 x 78-1/2" (5,1 x 10,2 x 199,4 cm)	
	<input type="checkbox"/> x2  3/8 x 48 x 84" (1 x 121,9 x 213,4 cm)	
<b>RAFTERS</b>	<input type="checkbox"/> x4 	
	<input type="checkbox"/> x4 <b>ADA</b>  2 x 4 x 77-15/16" (5,1 x 10,2 x 198 cm)	
	<input type="checkbox"/> x1 <b>TP</b>  2 x 4 x 96" (5,1 x 10,2 x 243,9 cm)	
<b>ROOF PANELS</b>	Roof panels are 7/16" (1,1 cm) thick.	<b>HARDWARE</b>
	<input type="checkbox"/> x2  7/16" x 36-1/2" x 47-7/8" (1,1 x 92,7 x 121,6 cm)	
<input type="checkbox"/> x2  7/16" x 47-7/8" x 48" (1,1 x 6 x 121,9 cm)	<input type="checkbox"/> x12  1-1/4" (3,2 cm)	

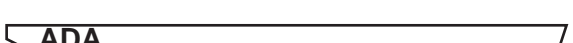
## 12' x 8' EXTENDER

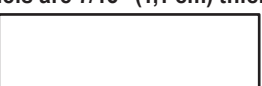
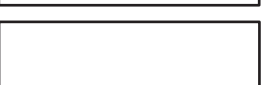
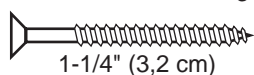
<b>WALL</b>	<input type="checkbox"/> x8 <b>AI</b>  2 x 4 x 78-1/2" (5,1 x 10,2 x 199,4 cm)	
	<input type="checkbox"/> x2 <b>VX</b>  2 x 6 x 96" (5,1 x 15,3 x 243,9 cm)	
	<input type="checkbox"/> x4  3/8 x 48 x 84" (1 x 121,9 x 213,4 cm)	
	<input type="checkbox"/> x8 	
<b>RAFTERS</b>	<input type="checkbox"/> x8 <b>ADA</b>  2 x 4 x 77-15/16" (5,1 x 10,2 x 198 cm)	
	<input type="checkbox"/> x2 <b>TP</b>  2 x 4 x 96" (5,1 x 10,2 x 243,9 cm)	
<b>ROOF PANELS</b>	Roof panels are 7/16" (1,1 cm) thick.	<b>HARDWARE</b>
	<input type="checkbox"/> x2  7/16" x 36-1/2" x 96" (1,1 x 92,7 x 243,9 cm)	
<input type="checkbox"/> x2  7/16" x 48" x 96" (1,1 x 121,9 x 243,9 cm)	<input type="checkbox"/> x24  1-1/4" (3,2 cm)	

## CONCRETE FOUNDATION

If you choose to install your kit on a concrete slab refer to the diagram below.  
Attach the sill plates on the foundation as shown, and continue on to page 14.

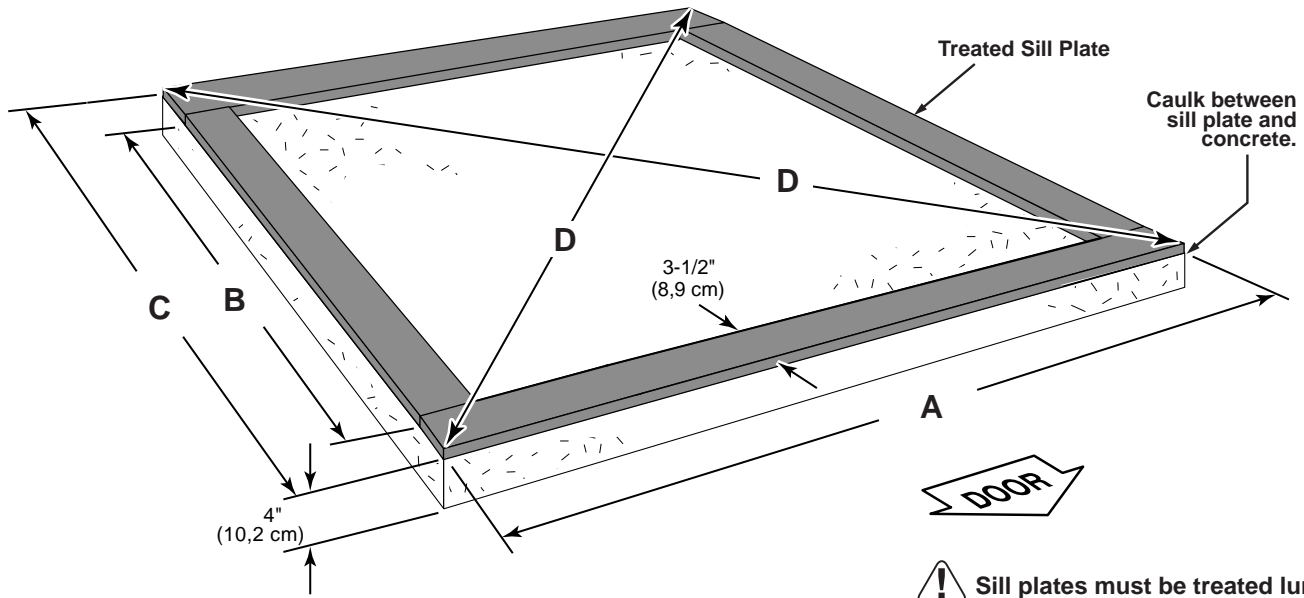

Sill plates must be treated lumber.

Building Size	Actual Floor Size	A	B	C	D
12'x12' (365,8 x 365,8 cm)	12'x12' (365,8 x 365,8 cm)	144" (365,8 cm)	137" (348 cm)	144" (365,8 cm)	203-5/8" (612,3 cm)

### 12' x 12' Building Requires:

- x2 2 x 4 x 12' (5,1 x 10,2 x 304,8 cm)   
  x2 2 x 4 x 12' (5,1 x 10,2 x 304,8 cm)  
 Cut down to: 137" (348 cm)
- x1 Caulk

Building Size	Actual Floor Size	A	B	C	D
12'x16' (304,8 x 487,7 cm)	12'x16' (304,8 x 487,7 cm)	144" (365,8 cm)	185" (469,9 cm)	192" (487,7 cm)	240" (609,6 cm)

### 12' x 16' Building Requires:

- x2 2 x 4 x 12' (5,1 x 10,2 x 304,8 cm)   
  x2 2 x 4 x 16' (5,1 x 10,2 x 426,7 cm)
- x1 Caulk   
 Cut down to: 185" (469,9 cm)

Building Size	Actual Floor Size	A	B	C	D
12'x20' (304,8 x 609,6 cm)	12'x20' (304,8 x 609,6 cm)	144" (365,8 cm)	233" (591,8 cm)	240" (609,6 cm)	279-7/8" (710,6 cm)

### 12' x 20' Building Requires:

- x2 2 x 4 x 12' (5,1 x 10,2 x 304,8 cm)   
  x2 2 x 4 x 16' (5,1 x 10,2 x 426,7 cm)
- x1 Caulk   
  x1 2 x 4 x 8' (5,1 x 10,2 x 243,8 cm)  
 Cut (2): 48" (121,9 cm)

Building Size	Actual Floor Size	A	B	C	D
12'x24' (304,8 x 731,5 cm)	12'x24' (304,8 x 731,5 cm)	144" (365,8 cm)	281" (713,7 cm)	288" (619,8 cm)	322" (817,9 cm)

### 12' x 24' Building Requires:

- x2 2 x 4 x 12' (5,1 x 10,2 x 304,8 cm)   
  x2 2 x 4 x 16' (5,1 x 10,2 x 426,7 cm)
- x2 Caulk   
  x2 2 x 4 x 8' (5,1 x 10,2 x 243,8 cm)  
 Cut (2): 89" (226,1 cm)

Allow new concrete slabs to cure for at least seven (7) days.

- A treated 2 x 4 (5,1 x 10,2 cm) sill plate is required when installing your shed on concrete. Purchase full length treated lumber, or butt shorter pieces end-to-end and seal seams with caulk.
- Use a high quality exterior grade caulk beneath all sill plates.
- Fasten 2 x 4 (5,1 x 10,2 cm) sill plates to slab using approved concrete anchors (fasteners not included).
- Check local code for concrete foundation requirements.

## OPTIONAL WOOD FRAME FLOOR LEVELING OPTIONS

There are multiple ways to level your floor frame. Our recommended leveling method is shown below.

**Leveling materials are not included in this kit.**

### PREFERRED METHOD - 4x4 TREATED RUNNERS (Typical for 12' x 12' Kit)

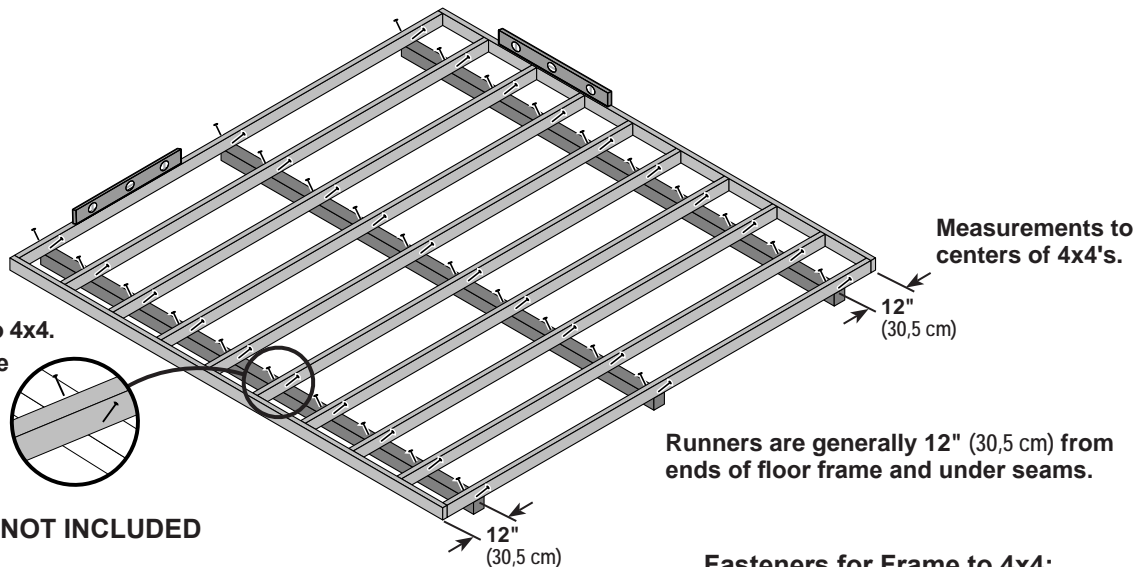

- 3" Screws angled into 4x4.
- (2) at each point frame and 4x4 touch.

Runners are generally 12" (30,5 cm) from ends of floor frame and under seams.

**! FLOOR FRAME NOT INCLUDED**

#### MATERIAL REQUIRED: [TREATED LUMBER]

- |                  |   |
|------------------|---|
| <b>12' x 12'</b> | <input type="checkbox"/> <b>x3</b> 4 x 4 x 12' (10,2 x 10,2 x 304,8 cm)   |
| <b>12' x 16'</b> | <input type="checkbox"/> <b>x3</b> 4 x 4 x 16' (10,2 x 10,2 x 487,7 cm)   |
| <b>12' x 20'</b> | <input type="checkbox"/> <b>(3)</b> 4 x 4 x 16' (10,2 x 10,2 x 487,7 cm) and:<br><b>(1)</b> 4 x 4 x 12' (10,2 x 10,2 x 144 cm) cut to <b>(3)</b> 48" (121,9 cm) |
| <b>12' x 24'</b> | <input type="checkbox"/> <b>(3)</b> 4 x 4 x 16' (10,2 x 10,2 x 487,7 cm) and:<br><b>(3)</b> 4 x 4 x 8' (10,2 x 10,2 x 243,8 cm)                                 |

**Fasteners for Frame to 4x4:**  
(3" Screws shown as one option.)  
Minimum 3" screws / exterior grade.

- |                                      |  |             |
|--------------------------------------|--|-------------|
| <input type="checkbox"/> <b>x60</b>  |  | 3" (7,6 cm) |
| <input type="checkbox"/> <b>x78</b>  |  | 3" (7,6 cm) |
| <input type="checkbox"/> <b>x96</b>  |  | 3" (7,6 cm) |
| <input type="checkbox"/> <b>x114</b> |  | 3" (7,6 cm) |

**! Use only wood treated for ground contact and fasteners approved for use with treated wood.**

**! Always support frame seams.**

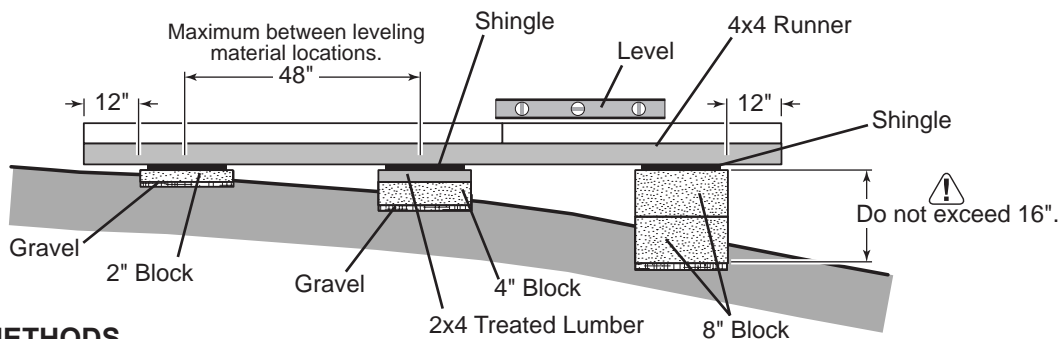

#### LEVELING METHODS

- Level under 4x4 runners only.
- Locate leveling material 12" from ends of runners and no more than 48" apart.
- Asphalt shingles should be used between 4x4 runners and blocks or treated lumber. Never use shingles in direct contact with ground.
- For best results and aiding in water drainage use gravel under each concrete block.

#### LEVELING MATERIALS

- Gravel
- Solid Masonry Blocks in 1", 2", 4" or 8" thickness
- 2x4 Treated Lumber
- Asphalt Shingles

**! Leveling higher than 16" not recommended.**

## LEVELING & SQUARING THE FLOOR FRAME (Not Included)

**STOP!**



### LEVEL AND SQUARE FLOOR FRAME



**STOP!**

Before attaching floor decking, it is important to level and square the floor frame.  
A level and square floor frame is required to correctly construct your shed.

See page 10 for the preferred floor leveling method.

*Use a level and ensure the frame is level before applying floor panels.*

**BEGIN**

- 1 Check for frame squareness by measuring diagonally across the corners (**diagonal measurement D**). If the measurements are the same, the frame is square. Use the chart below to determine measurement D.

SHED SIZE	D
<b>12' x 12'</b>	<b>203-5/8"</b> (612,3 cm)
<b>12' x 16'</b>	<b>240"</b> (609,6 cm)
<b>12' x 20'</b>	<b>279-7/8"</b> (710,9 cm)
<b>12' x 24'</b>	<b>322"</b> (817,9 cm)

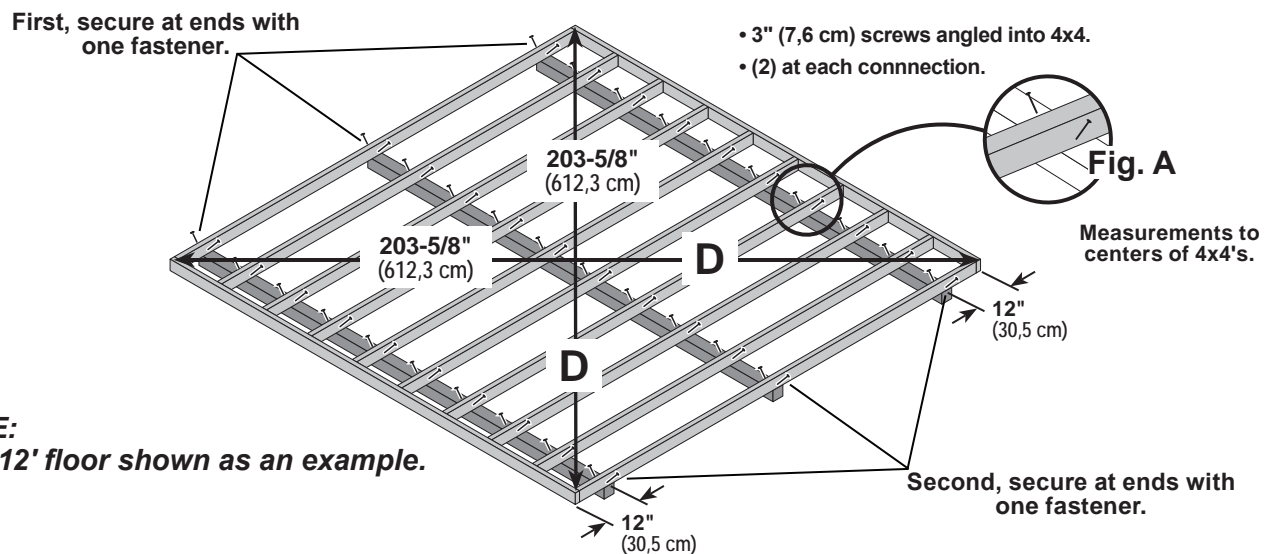

**NOTE:**  
12' x 12' floor shown as an example.

**4x4 runners are generally installed 12" (30,5 cm) from ends of floor frame and under any seams.**

- 2 After the frame is level and square, secure one side of frame to 4x4 runners using one fastener at ends of each runner.

At the opposite end of the frame, secure the frame to 4x4 runners with one fastener at the ends of each runner, ensuring that the frame remains square.

Fasten the frame to the 4x4 runners with (2) 3" screws at each connection (**Fig. A**).



Your floor frame is now level.

**! IMPORTANT!**

*NOTE: 12' x 12' Gable shown standard throughout manual*



**Ensure the floor frame is level after installing floor panels. Re-level if needed.**

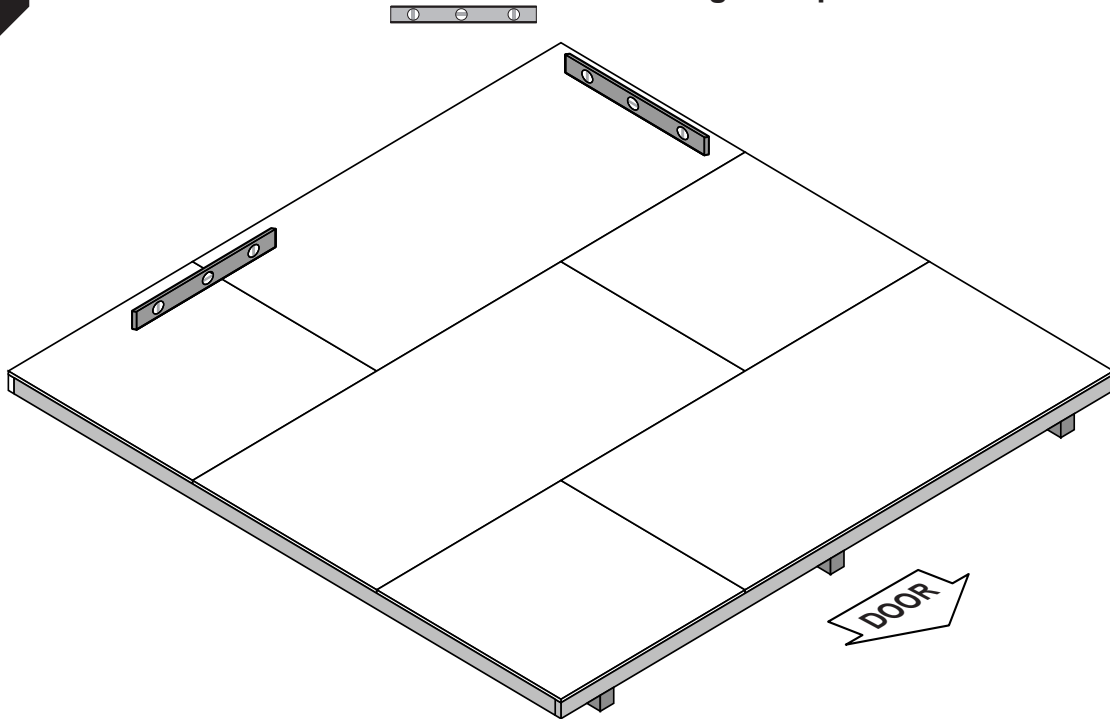

**HINT:**

- The floor should be used as a stable work surface for wall construction.
- Organize your assembly procedure during the build process to avoid over-handling of the walls.

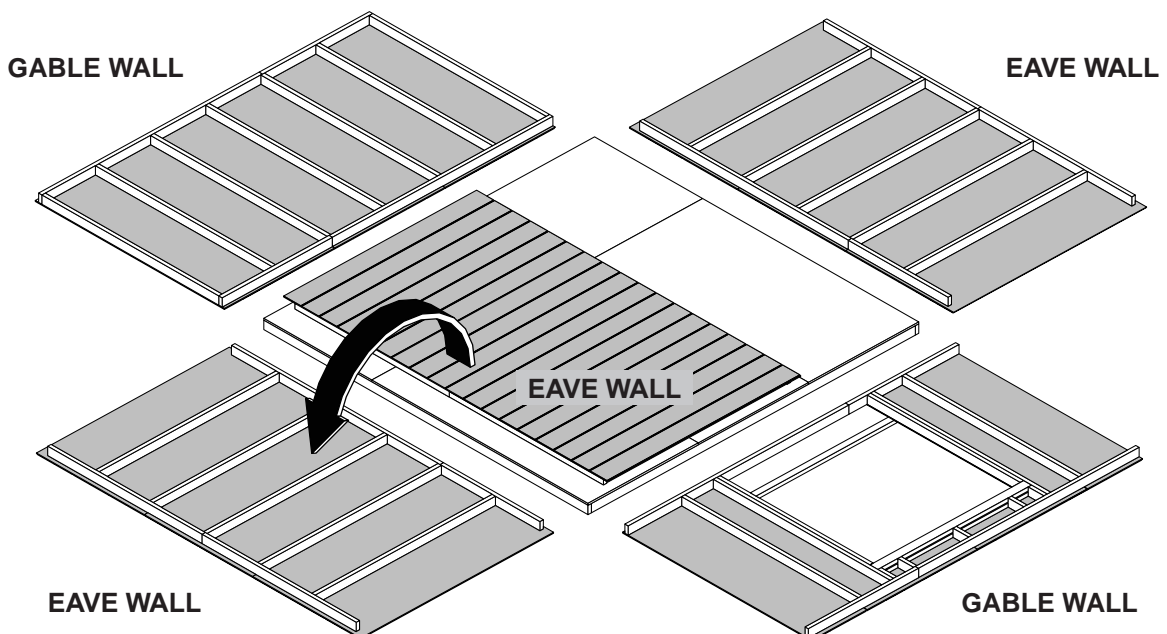

# WALL INDEX



**IMPORTANT!** Build door header before building any walls (see page 14).

## 12' x 12'

After assembling the walls for your 12' x 12' shed, go to page 28 for wall installation.

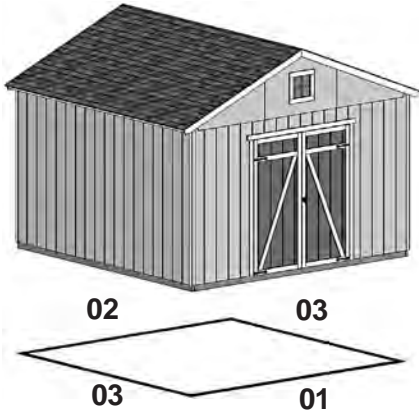

### 12' x 12'

Wall 01: Page 16

Wall 02: Page 18

Wall 03: Page 20 (Build 2 eave walls)

## 12' x 16'

After assembling the walls for your 12' x 16' shed, go to page 33 for wall installation.

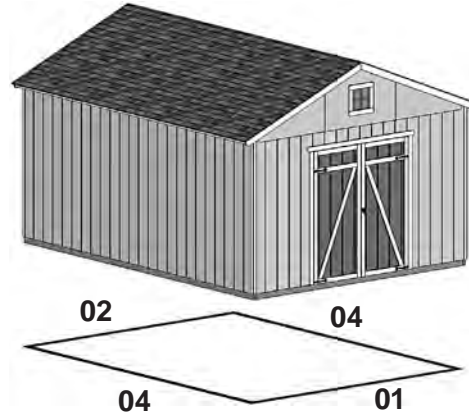

### 12' x 16'

Wall 01: Page 16

Wall 02: Page 18

Wall 04: Page 22 (Build 2 eave walls)

## 12' x 20'

After assembling the walls for your 12' x 20' shed, go to page 39 for wall installation.

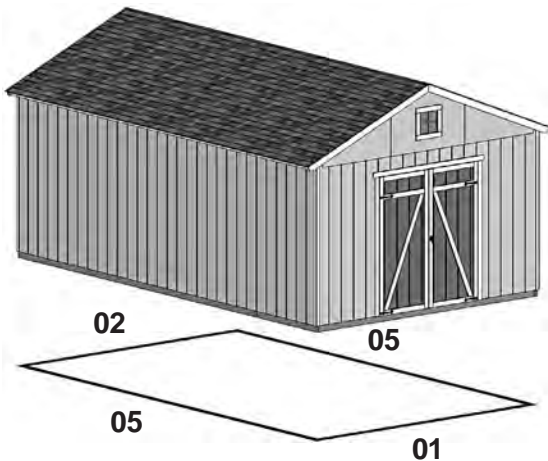

### 12' x 20'

Wall 01: Page 16

Wall 02: Page 18

Wall 05: Page 24 (Build 2 eave walls)

## 12' x 24'

After assembling the walls for your 12' x 24' shed, go to page 45 for wall installation.

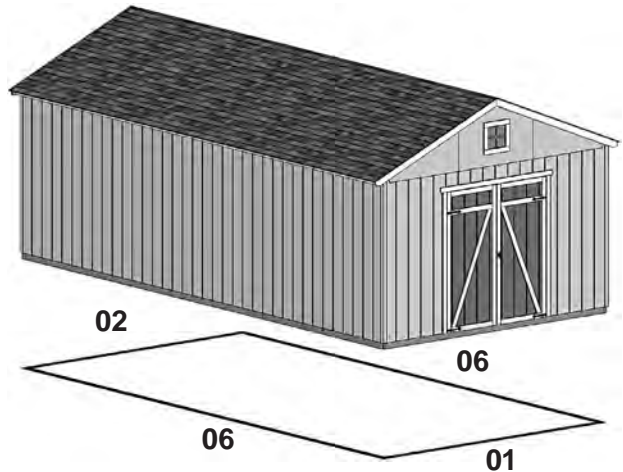

### 12' x 24'

Wall 01: Page 16

Wall 02: Page 18

Wall 06: Page 26 (Build 2 eave walls)

# DOOR HEADER

**STOP!**

*Assemble this door header before building any walls!*

**STOP!**

## PARTS REQUIRED:

x2 **AM**  
2 x 4 x 67" (5,1 x 10,2 x 170,2 cm)

x1  
7/16 x 3-1/4 x 66-3/4" (1,1 x 8,3 x 170,2 cm) **OSB**

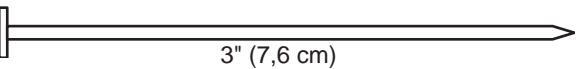
x18  3" (7,6 cm)

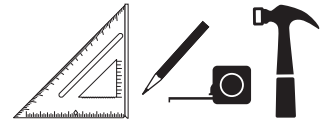

### ✓ BEGIN

- 1 Place (1) **AM** and **OSB** end-to-end on flat surface, flush in middle.  
Center **OSB** on top of **AM**.

Fasten together with 3" nails in the pattern shown.

- 2 Flip header assembly over and nail as shown on the other side.

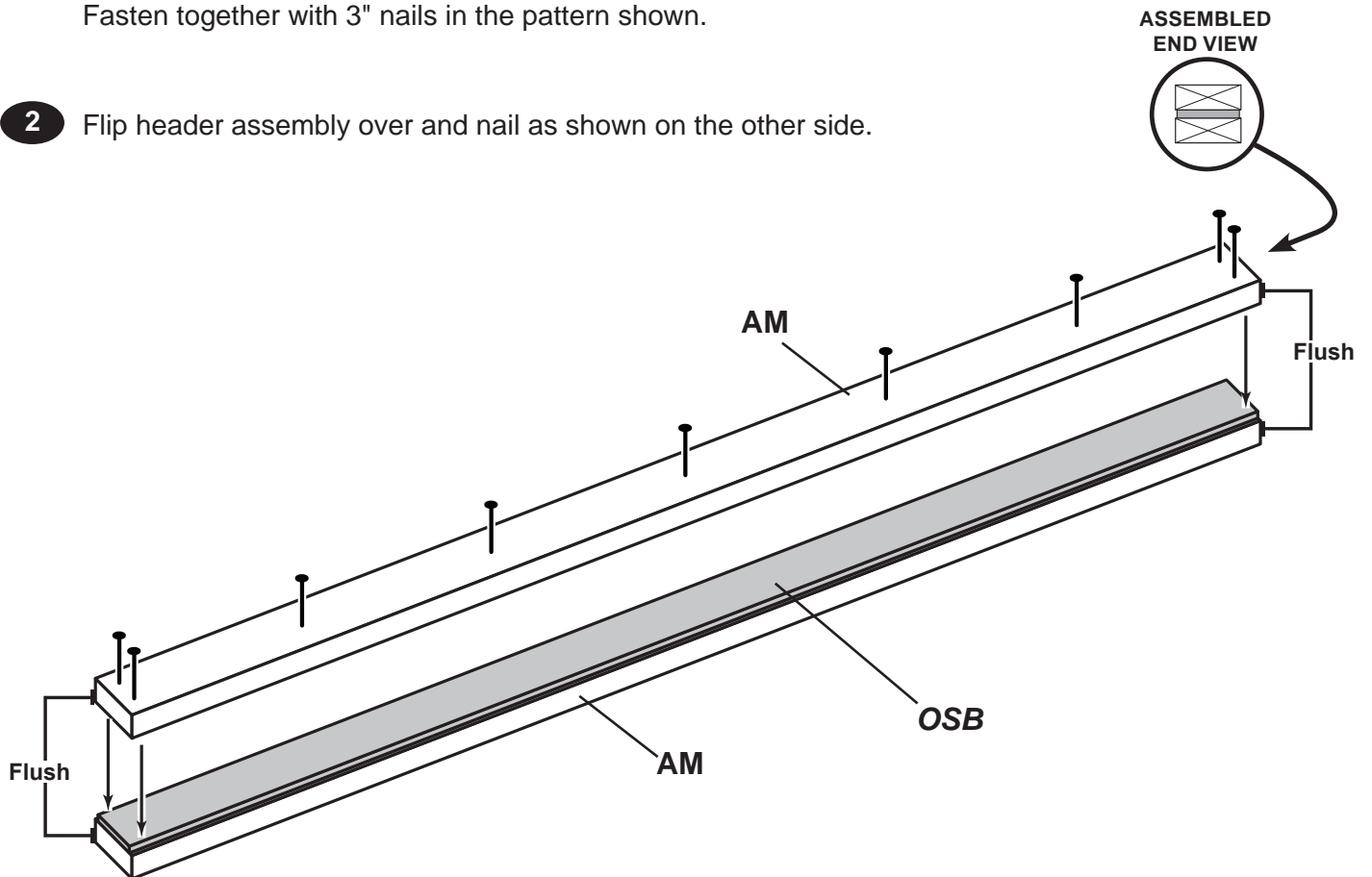

Your door header is now assembled.

# WALL PANEL INSTALLATION HINTS & EXAMPLES

## PARTS REQUIRED:

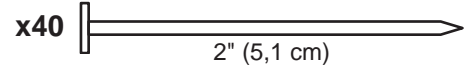
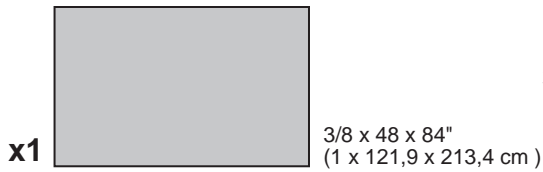

**Ensure your wall is square by installing one panel and squaring frame.**

**Install all wall panels with the primed side facing up.**

**BEGIN**

- Place a **48" X 84"** panel on the wall frame, as shown.  
 Locate the panel 1-1/2" above the top plate.  
 Use a 2 x 3 as a gauge block for the 1-1/2" top overhang measurement.  
 Use the gauge block to mark the 3/4" side measurement on the wall stud.  
 Secure panel with (2) 2" nails in the corners (**Fig. A**).

- Move to the opposite end. Using the long edge of the panel as a lever, move the panel side-to-side until you have a 3/4" measurement on the wall stud.  
 Secure corner with (2) 2" nails (**Fig. B**).  
 Secure panel with 2" nails spaced 6" apart on edges and 12" apart inside panel.  
**Note the panel lip-edge/square edge orientation.**

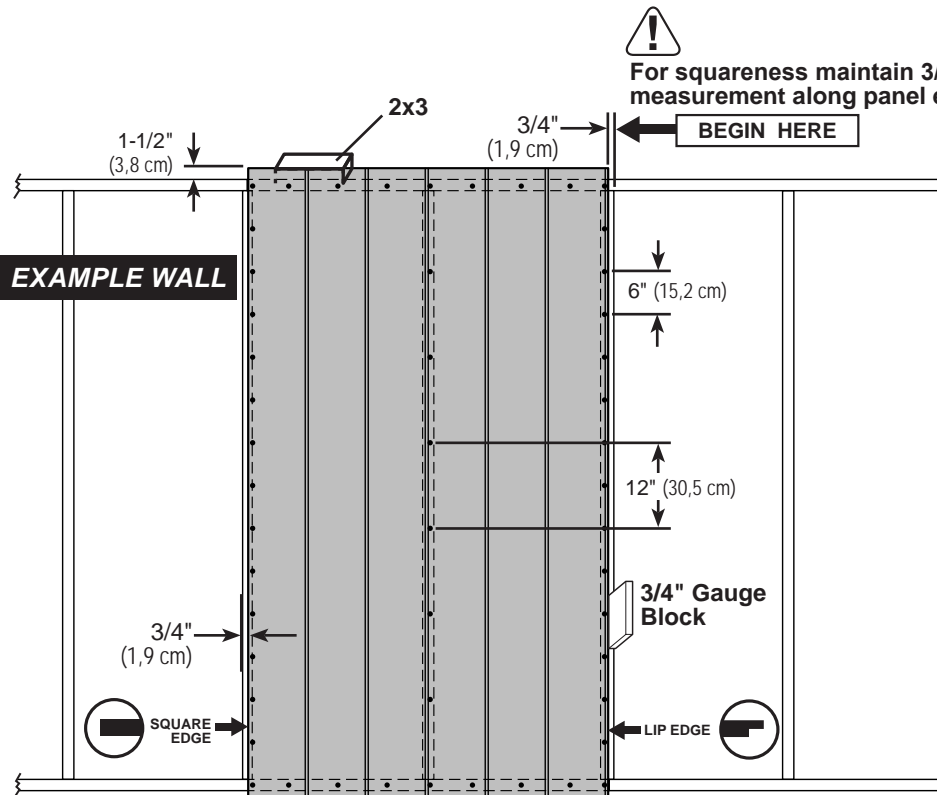
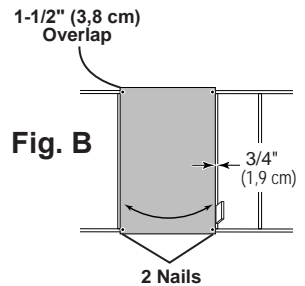
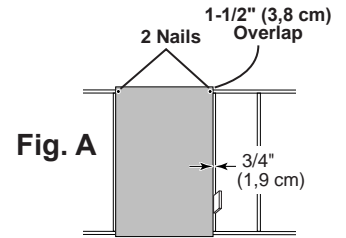

**For squareness maintain 3/4" and 1-1/2" measurement along panel edge.**

## HINTS

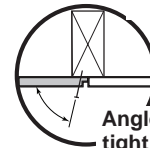

**Angle nail to draw panels tight at seams.**



**Do not nail in groove.**

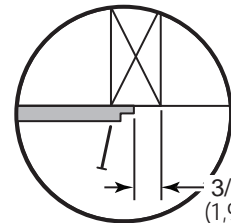

**3/4" (1,9 cm)**

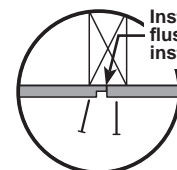

**Install 2nd panel flush to installed panel.**

# GABLE WALL 01 WITH DOOR

## PARTS REQUIRED: x5 **AL**

x2 **SP** 2 x 4 x 48" (5,1 x 10,2 x 121,9 cm)

x6 **AI** 2 x 4 x 78-1/2" (5,1 x 10,2 x 199,4 cm)

x2 **TP** 2 x 4 x 96" (5,1 x 10,2 x 243,8 cm)

x1 **Pre Assembled Header**

x2 **UM** 2 x 4 x 68" (5,1 x 10,2 x 172,7 cm)

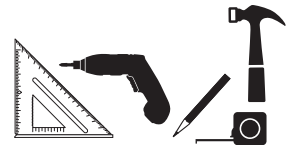
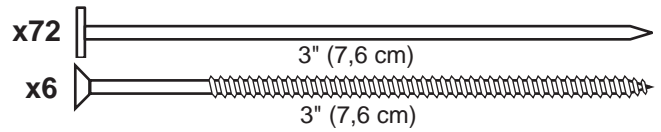

### ✓ BEGIN

- 1 Orient parts on edge on floor as shown. Measure and mark from end of boards.  
Orient **Pre Assembled Header** as shown (**Fig. A**).  
Secure with (2) 3" nails at each connection and (4) 3" nails at seams.

- 2 Fasten (3) middle parts **AL** to **Pre Assembled Header** with (2) 3" screws (**Fig. B**).  
Fasten (2) end **AL** to studs **AI** with (4) 3" nails at each side.  
Secure parts **AL** to top plates with (2) 3" nails at each connection and (4) 3" nails at seam.

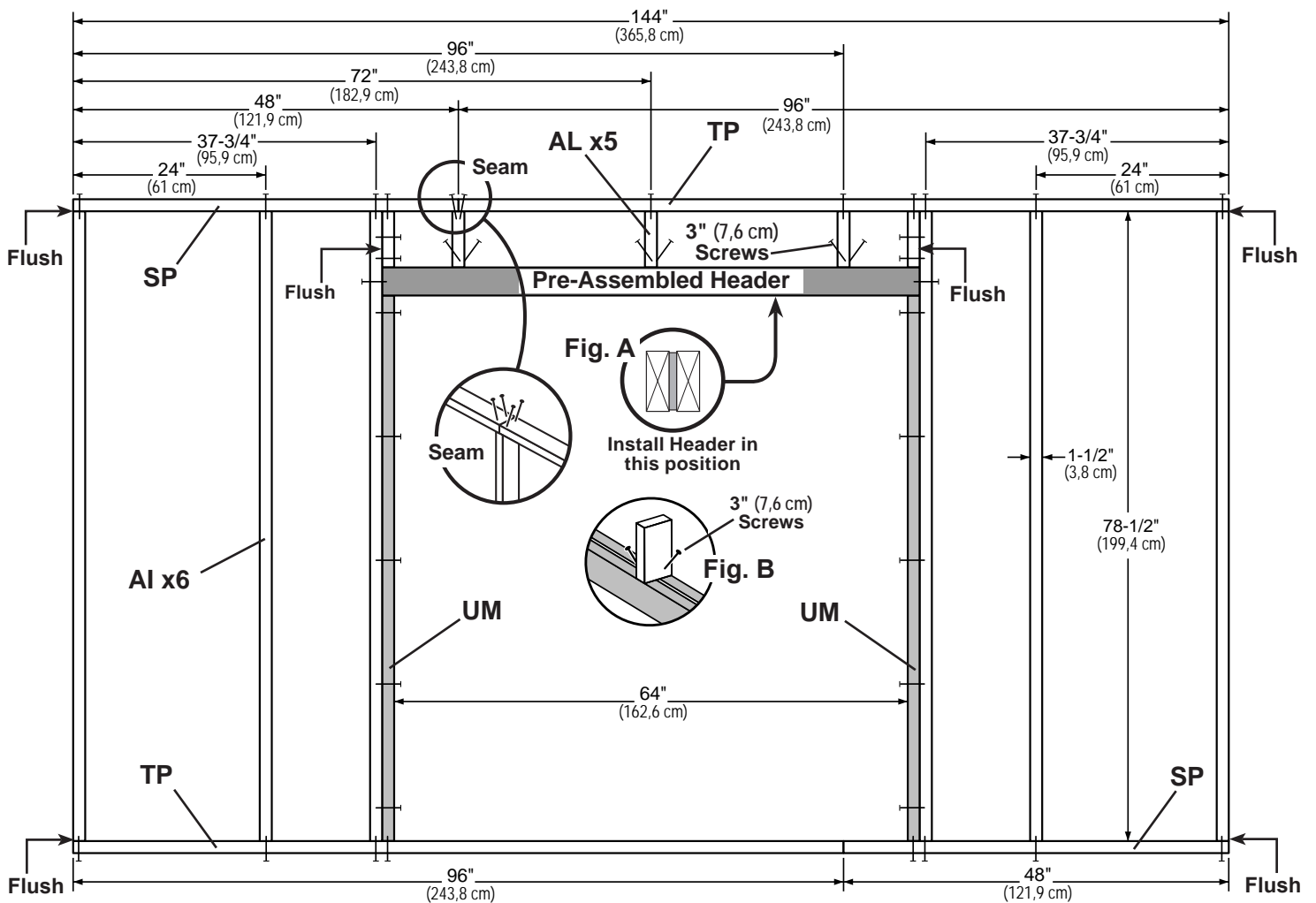

# GABLE WALL 01 WITH DOOR

## PARTS REQUIRED:

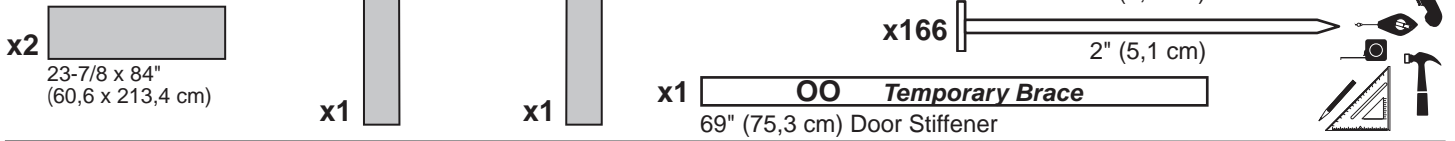

**3** Install the left panel 1-1/2" from the top plate. Use a 2x3 spacer for consistent measurement. Secure panel with 2" nails spaced 6" apart on edges.

**4** Install the right panel flush to installed panel, as shown. Ensure 64" (162,8 cm) door measurement. Use part OO as a temporary brace. Secure with (2) 3" screws.

Secure panels with 2" nails spaced 6" apart on edges.

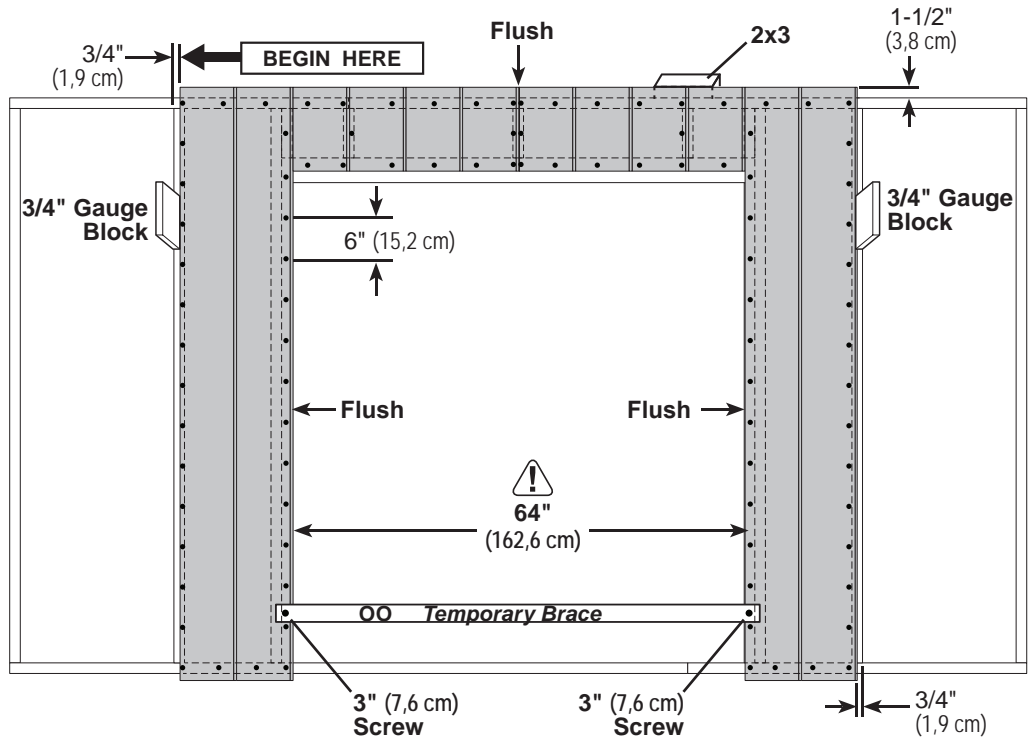

**5** Install (2) 11-7/8" x 84" panels flush to installed panels and 1-1/2" from the top plate.

Secure panels with 2" nails spaced 6" apart on edges.

**Note the panel lip-edge/square edge orientation.**

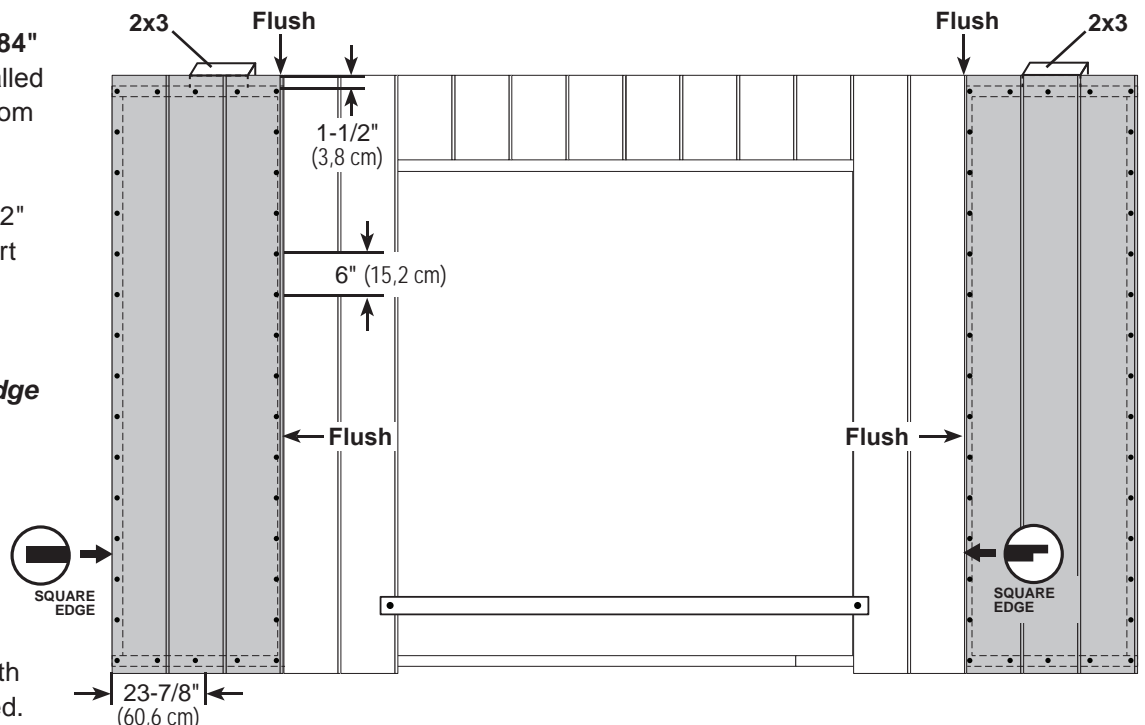

Your 12' gable wall with door is now assembled. Carefully flip the wall over.

# 12' GABLE WALL 02

## PARTS REQUIRED:

x2 **SP**  
2 x 4 x 48" (5,1 x 10,2 x 121,9 cm)

x7 **AI**  
2 x 4 x 78-1/2" (5,1 x 10,2 x 199,4 cm)

x2 **TP**  
2 x 4 x 96" (5,1 x 10,2 x 243,8 cm)

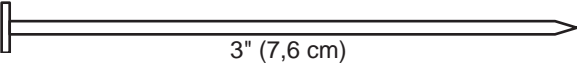
x32  3" (7,6 cm)



### ✓ BEGIN

- 1 Orient parts on edge on floor as shown. Measure and mark from end of boards.  
Secure with (2) 3" nails at each connection and (4) 3" nails at seams.

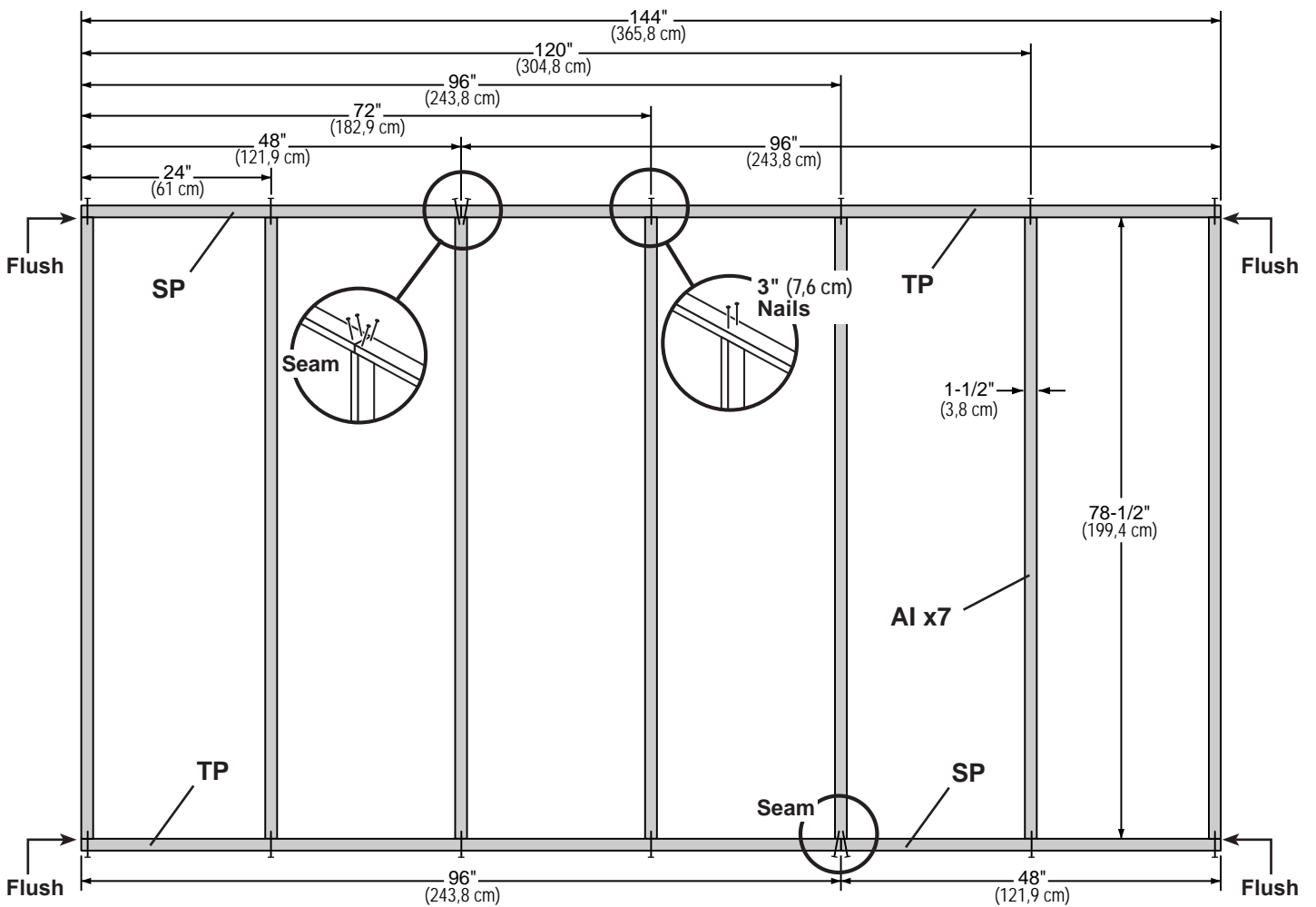
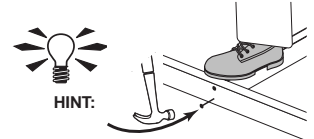

# 12' GABLE WALL 02

## PARTS REQUIRED:

- x1  23-7/8" x 84"  
(60,6 x 213,4 cm)
- x2  48" x 84"  
(121,9 x 213,4 cm)

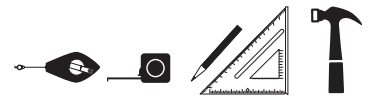
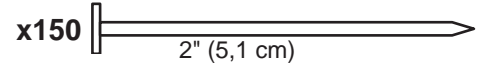

**2**  
Install 48" x 84" panel 1-1/2" from the top plate.

Use a 2x3 spacer for consistent measurement.

Secure panel with 2" nails spaced 6" apart on edges and 12" inside panel.

**Note the panel lip-edge/square edge orientation.**

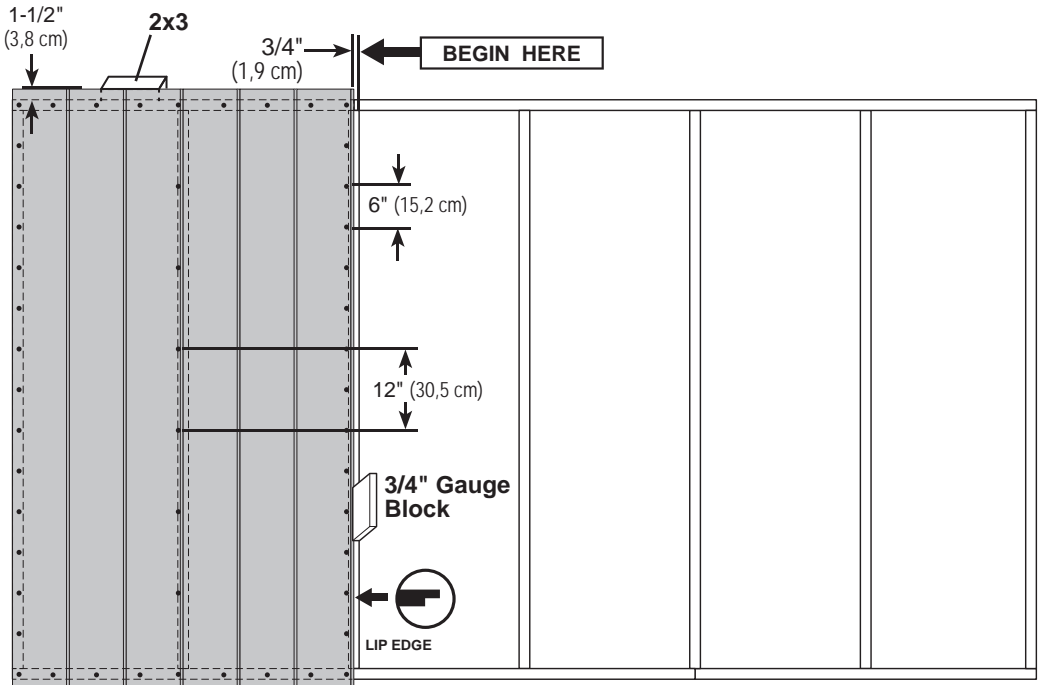

**3**  
Install (2) 48" x 84" panels flush to installed panels.

Locate panels 1-1/2" from the top plate.

Secure with 2" nails spaced 6" apart on edges and 12" apart inside panel.

**Note the panel lip-edge/square edge orientation.**

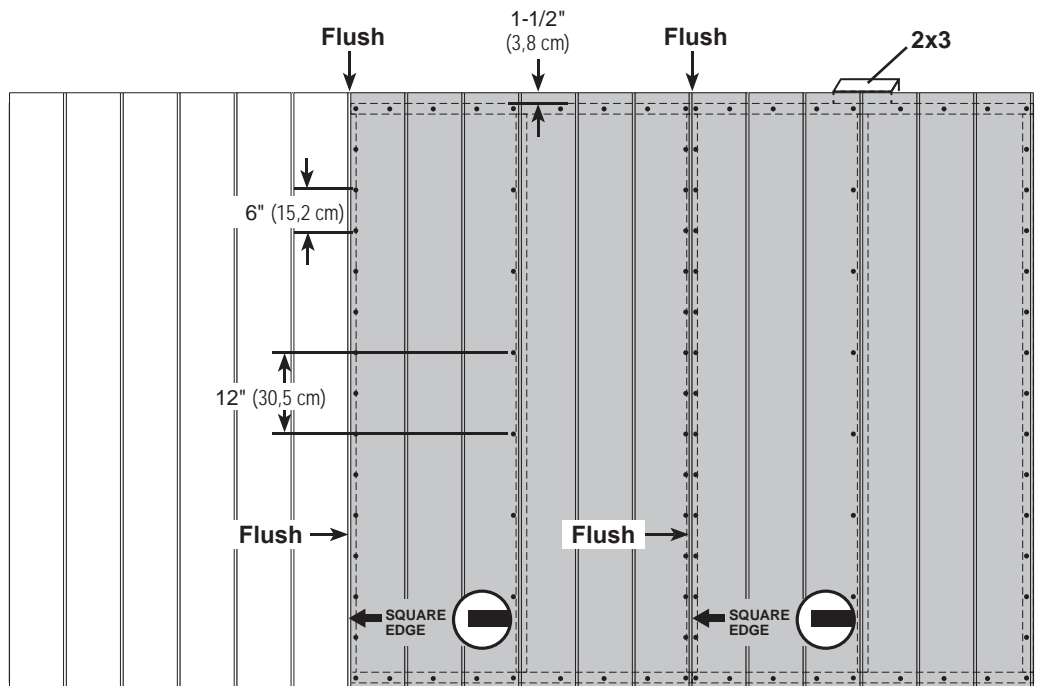

Your 12' gable wall 02 is now assembled.  
Carefully flip the wall over.

# 12' EAVE WALL 03

## PARTS REQUIRED:

x1 **HVC**  
2 x 4 x 44-3/8" (5,1 x 10,2 x 112,7 cm)

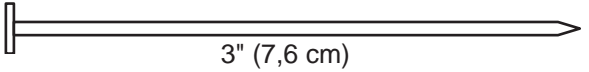
x48  3" (7,6 cm)

x2 **YFA**  
2 x 4 x 68-1/2" (5,1 x 10,2 x 174 cm)

x1 **TJ**  
2 x 4 x 92-5/8" (5,1 x 10,2 x 235 cm)

x5 **AI**  
2 x 4 x 78-1/2" (5,1 x 10,2 x 199,4 cm)

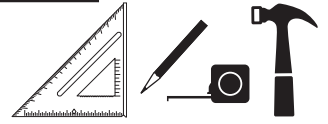

**Build two identical walls.**

**BEGIN**

**1** Orient parts on edge on floor. Measure and mark from end of boards.

Secure with (2) 3" nails at each connection and (4) 3" nails at seams.

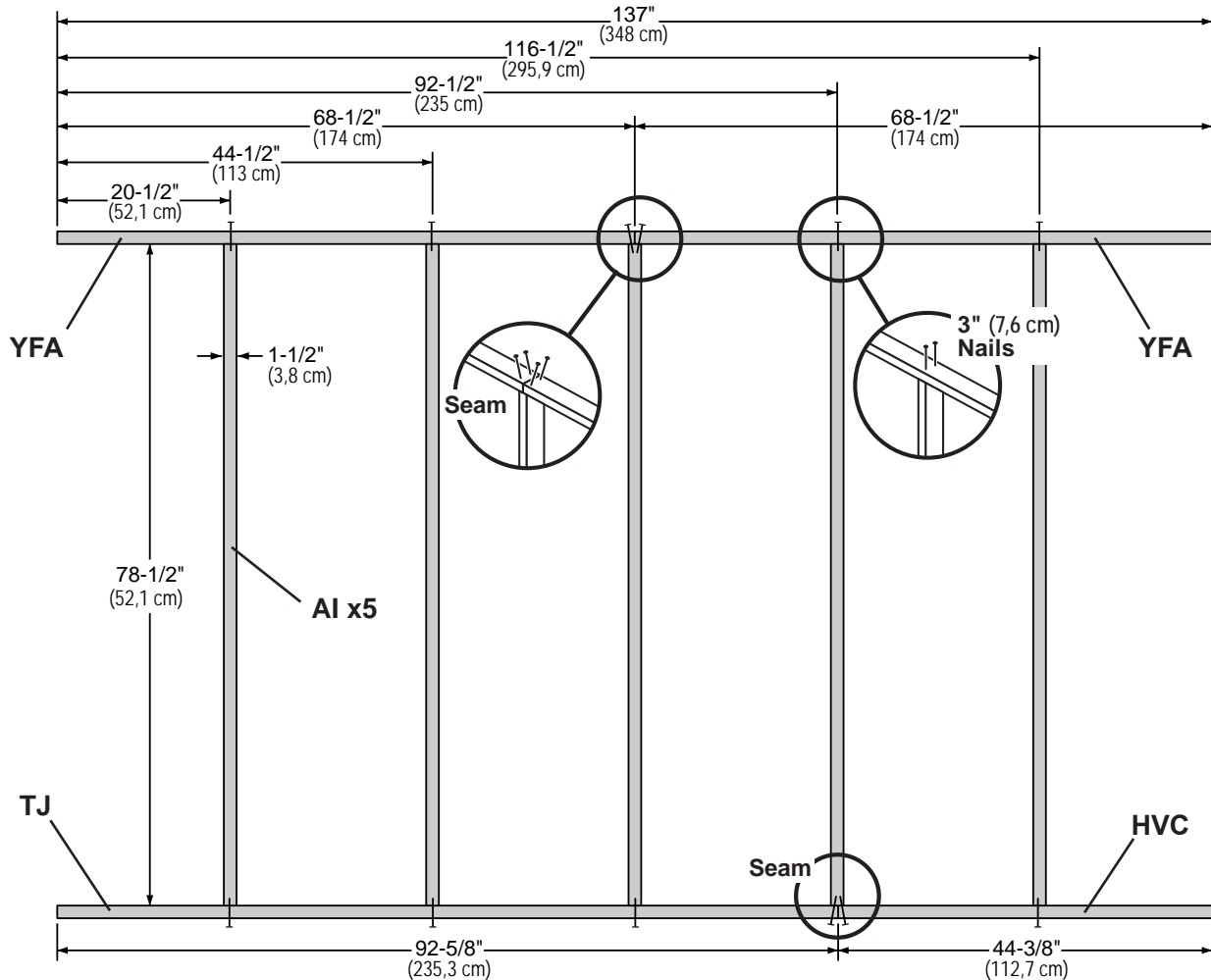
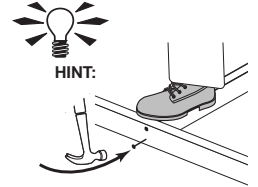

# 12' EAVE WALL 03

## PARTS REQUIRED:

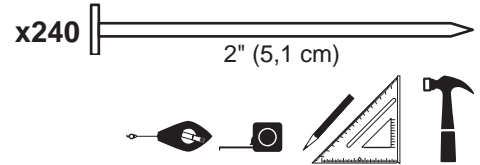

**2**

Install 48" x 84" panel 1-1/2" from the top plate.

Use a 2x3 spacer for consistent measurement.

Secure panel with 2" nails spaced 6" apart on edges and 12" inside panel.

**Note the panel lip-edge/square edge orientation.**

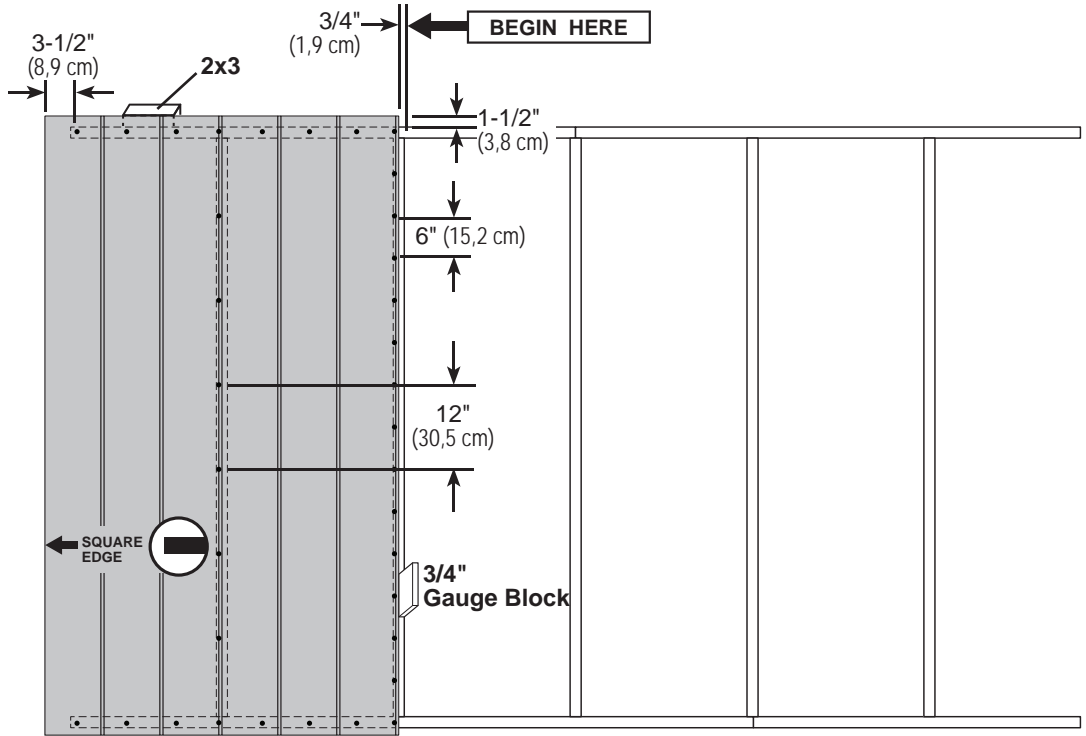

**3**

Install next (2) 48" x 84" panels flush to installed panels.

Locate panels 1-1/2" from the top plate.

Secure with 2" nails spaced 6" apart on edges and 12" inside panel.

**Note the panel lip-edge/square edge orientation.**

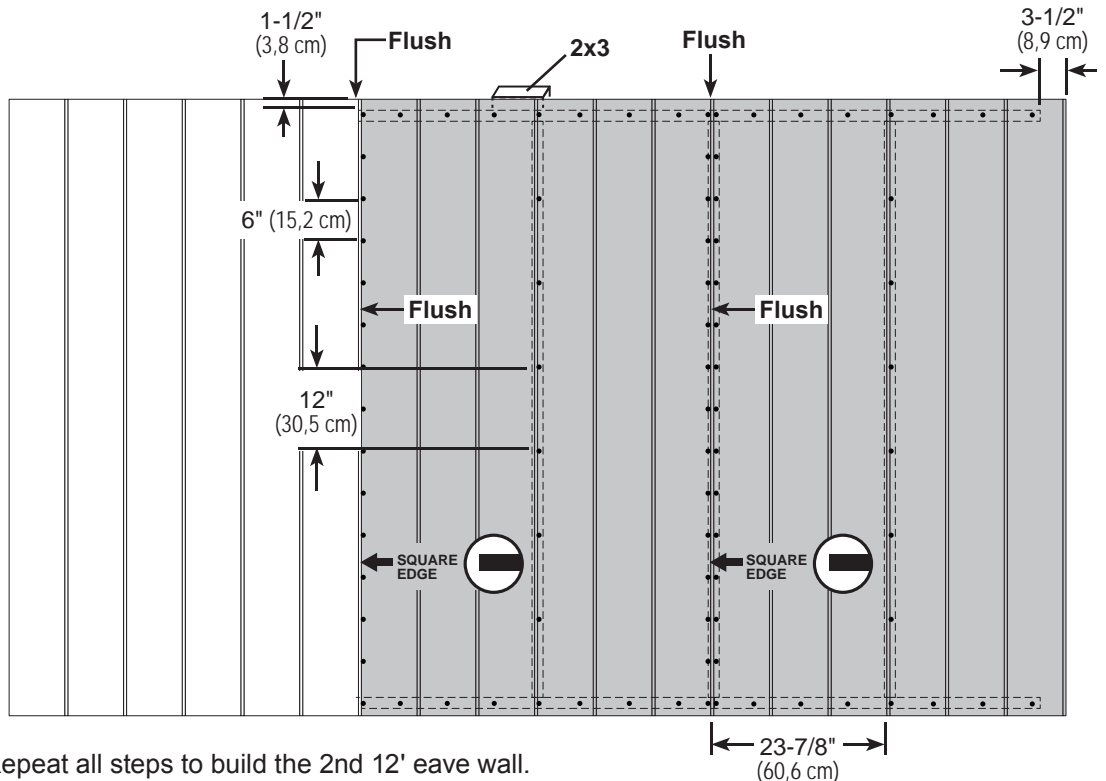

Carefully flip the wall over. Repeat all steps to build the 2nd 12' eave wall. Your 12' eave walls are now assembled.

# 16' EAVE WALL 04

## PARTS REQUIRED:

x1 **HVC**  
2 x 4 x 44-3/8" (5,1 x 10,2 x 112,7 cm)

x2 **SP**  
2 x 4 x 48" (5,1 x 10,2 x 121,9 cm)

x2 **YFA**  
2 x 4 x 68-1/2" (5,1 x 10,2 x 174 cm)

x7 **AI**  
2 x 4 x 78-1/2" (5,1 x 10,2 x 199,4 cm)

x1 **TJ**  
2 x 4 x 92-5/8" (5,1 x 10,2 x 235 cm)

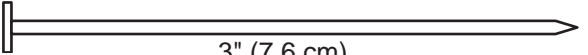
x72  3" (7,6 cm)

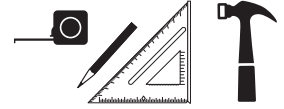

**Build two identical walls.**

**BEGIN**

- 1 Orient parts on edge on floor. Measure and mark from end of boards.  
Secure with (2) 3" nails at each connection and (4) 3" nails at seams.

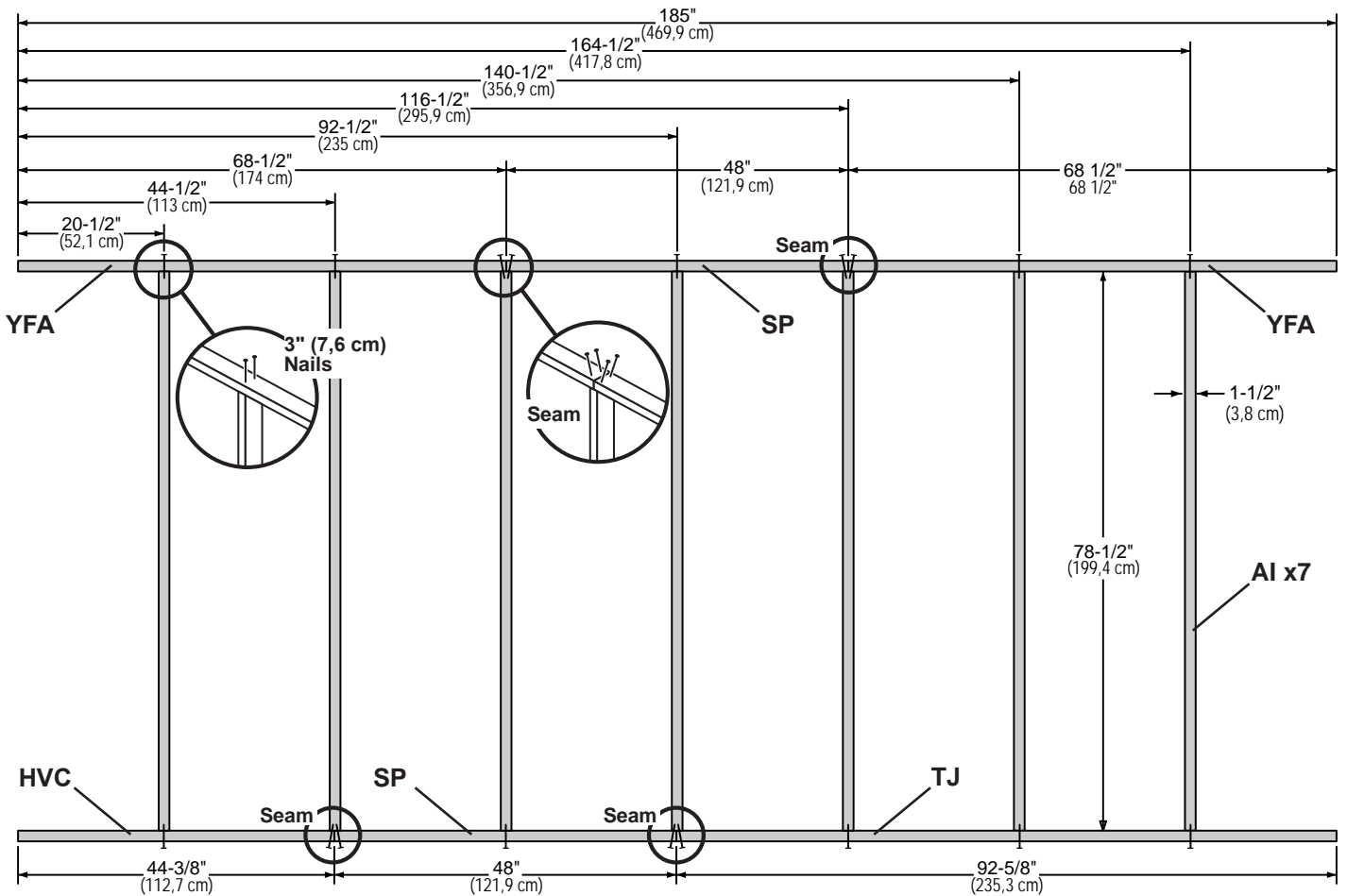
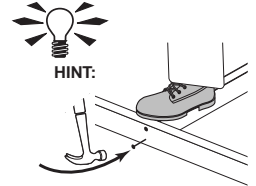

# 16' EAVE WALL 04

## PARTS REQUIRED:

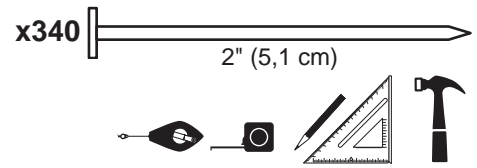
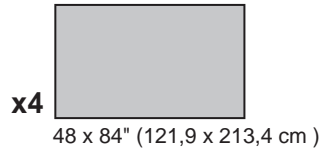

**2**

Install (1) 48" x 84" panel 1-1/2" from the top plate.

Use a 2x3 spacer for consistent measurement.

Secure panel with 2" nails spaced 6" apart on edges and 12" inside panel.

**Note the panel lip-edge/square edge orientation.**

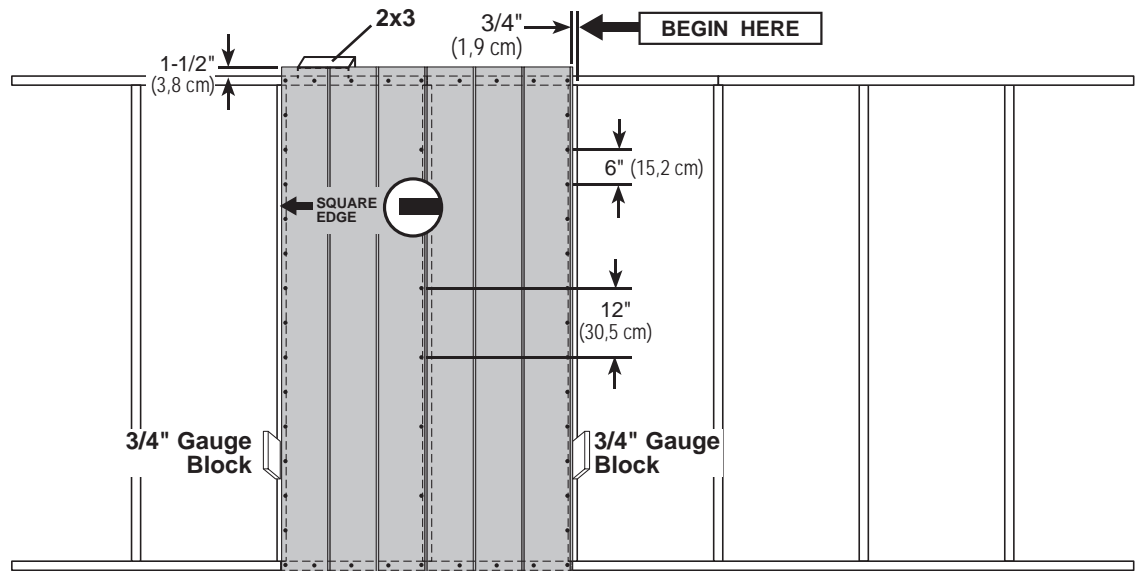

**3**

Install (3) 48" x 84" panels flush to installed panels.

Locate panels 1-1/2" from the top plate.

Secure with 2" nails spaced 6" apart on edges and 12" apart inside panel.

**Note the panel lip-edge/square edge orientation.**

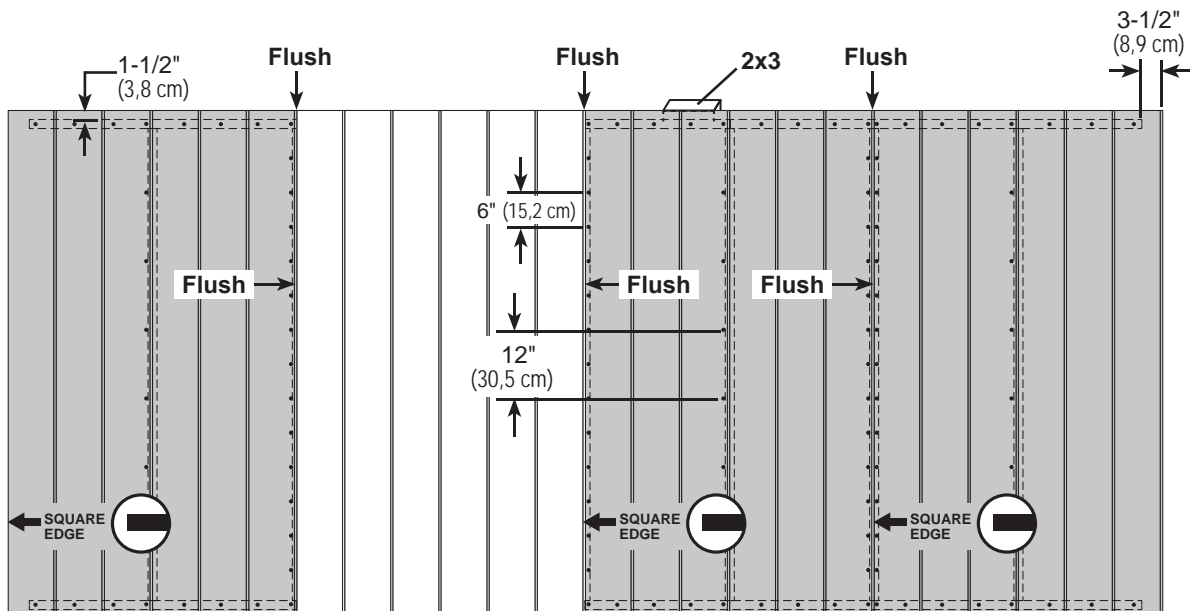

Carefully flip the wall over. Repeat all steps to build the 2nd 16' eave wall. Your 16' eave walls are now assembled.

## 20' EAVE WALL 05

### PARTS REQUIRED:

**x2** **YFA**  
2 x 4 x 68-1/2" (5,1 x 10,2 x 174 cm)

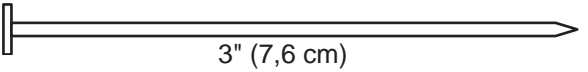
**x88**  3" (7,6 cm)

**x9** **AI**  
2 x 4 x 78-1/2" (5,1 x 10,2 x 199,4 cm)

**x1** **HVC**  
2 x 4 x 44-3/8" (5,1 x 10,2 x 112,7 cm)

**x1** **TJ**  
2 x 4 x 92-5/8" (5,1 x 10,2 x 235 cm)

**x2** **TP**  
2 x 4 x 96" (5,1 x 10,2 x 243,8 cm)

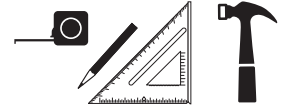

**Build two identical walls.**

**BEGIN**

- 1 Orient parts on edge on floor. Measure and mark from end of boards.  
Secure with (2) 3" nails at each connection and (4) 3" nails at seams.

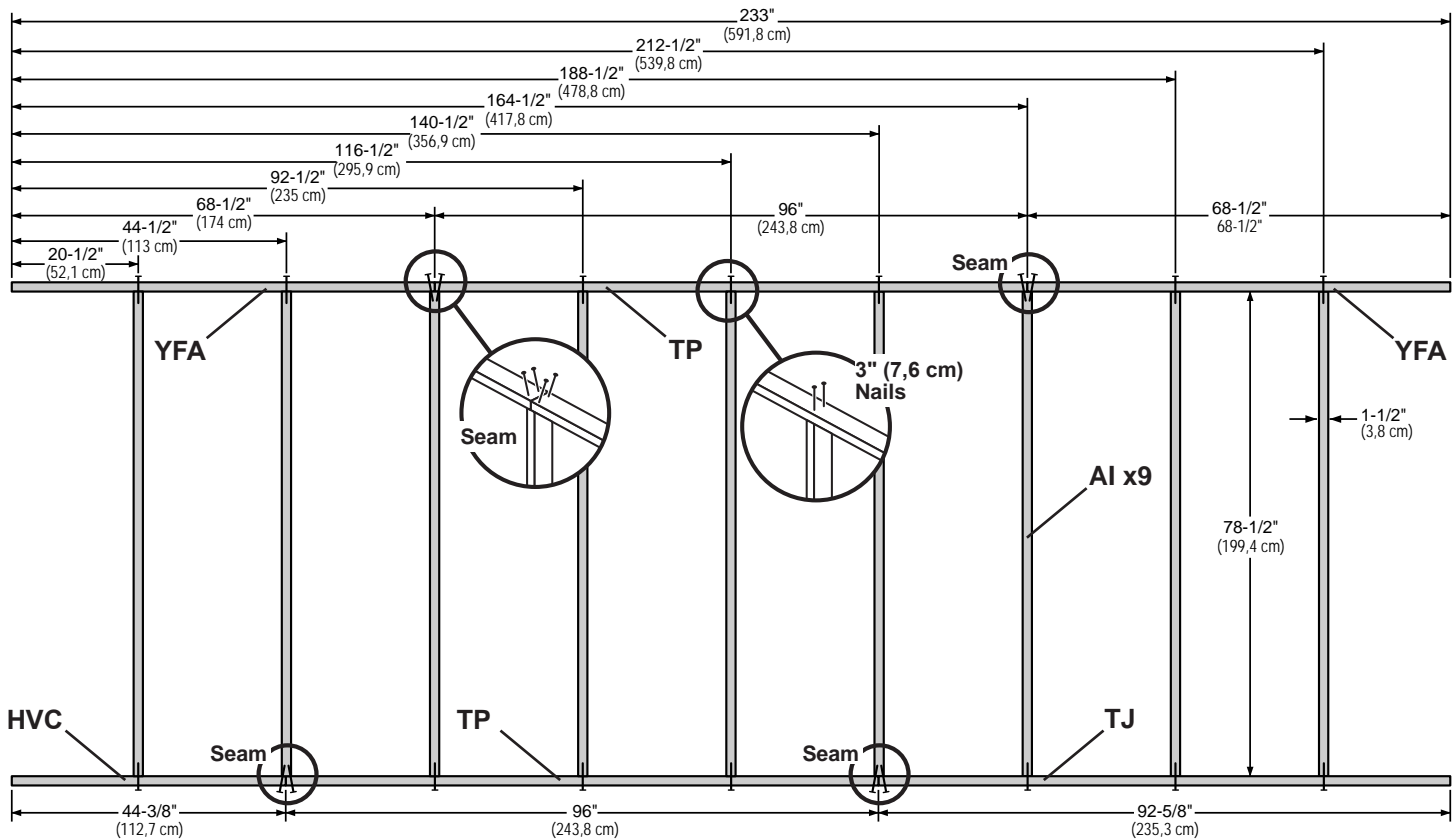
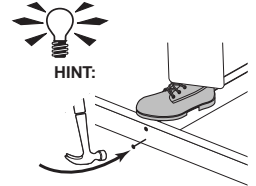

## 20' EAVE WALL 05

### PARTS REQUIRED:

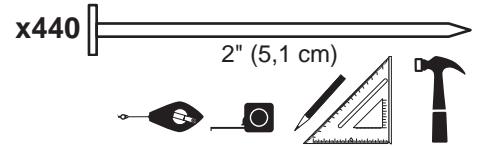
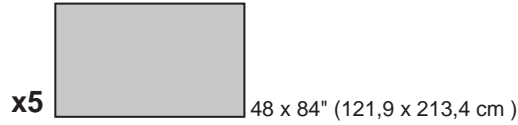

- 2** Install (1) 48" x 84" panel 1-1/2" from the top plate. Use a 2x3 spacer for consistent measurement.

Secure panel with 2" nails spaced 6" apart on edges and 12" inside panel.

*Note the panel lip-edge/square edge orientation.*

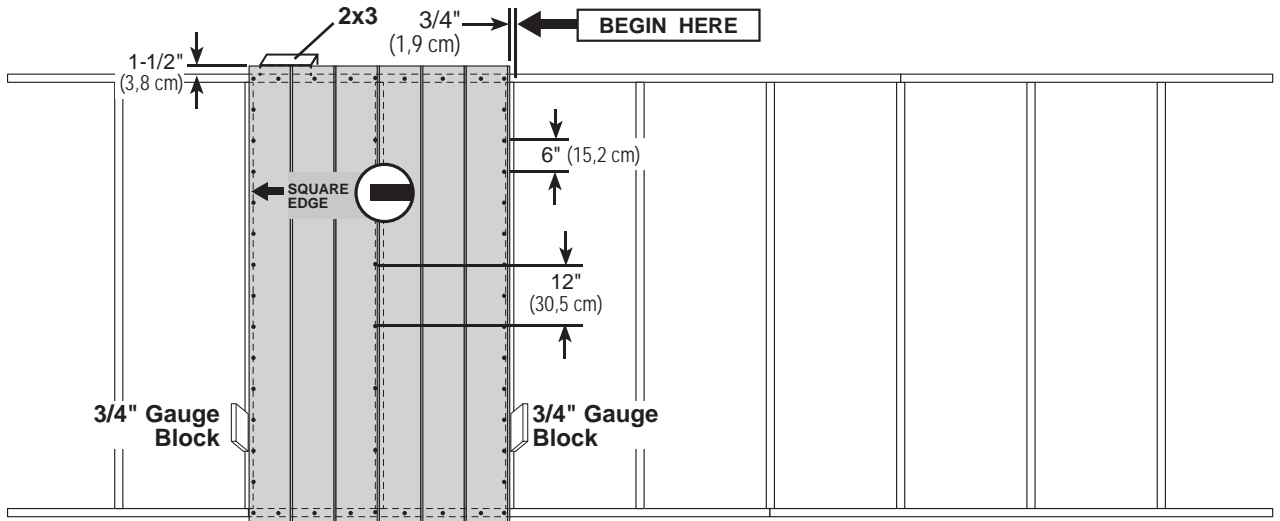

- 3** Install (4) 48" x 84" panels flush to installed panels. Locate panels 1-1/2" from the top plate.

Secure with 2" nails spaced 6" apart on edges and 12" apart inside panel.

*Note the panel lip-edge/square edge orientation.*

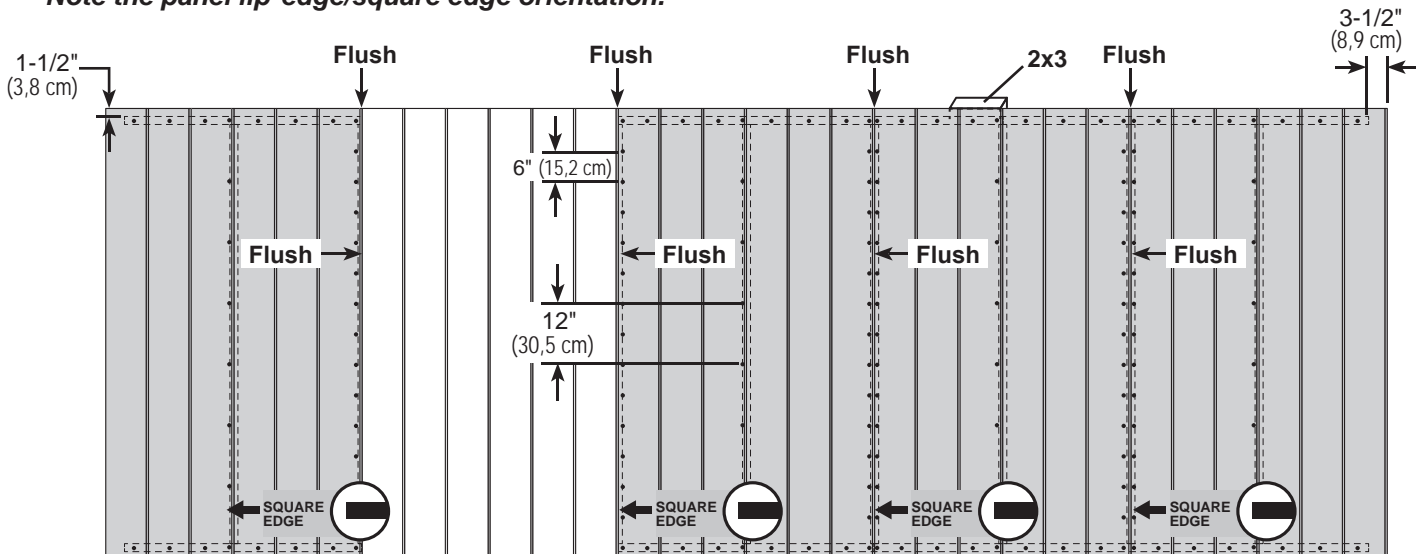

Carefully flip the wall over. Repeat all steps to build the 2nd 20' eave wall.  
Your 20' eave walls are now assembled.

## 24' EAVE WALL 06

### PARTS REQUIRED:

**x2 YFA**  
2 x 4 x 68-1/2" (5,1 x 10,2 x 174 cm)

**x11 AI**  
2 x 4 x 78-1/2" (5,1 x 10,2 x 199,4 cm)

**x1 TJ**  
2 x 4 x 92-5/8" (5,1 x 10,2 x 235 cm)

**x2 TP**  
2 x 4 x 96" (5,1 x 10,2 x 243,8 cm)

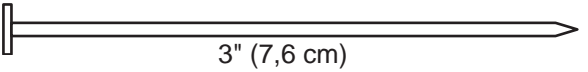
**x112**  3" (7,6 cm)

**x1 HVC**  
2 x 4 x 44-3/8" (5,1 x 10,2 x 112,7 cm)

**x2 SP**  
2 x 4 x 48" (5,1 x 10,2 x 121,9 cm)

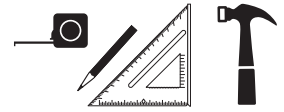

**Build two identical walls.**

**BEGIN**

- 1 Orient parts on edge on floor. Measure and mark from end of boards.  
Secure with (2) 3" nails at each connection and (4) 3" nails at seams.

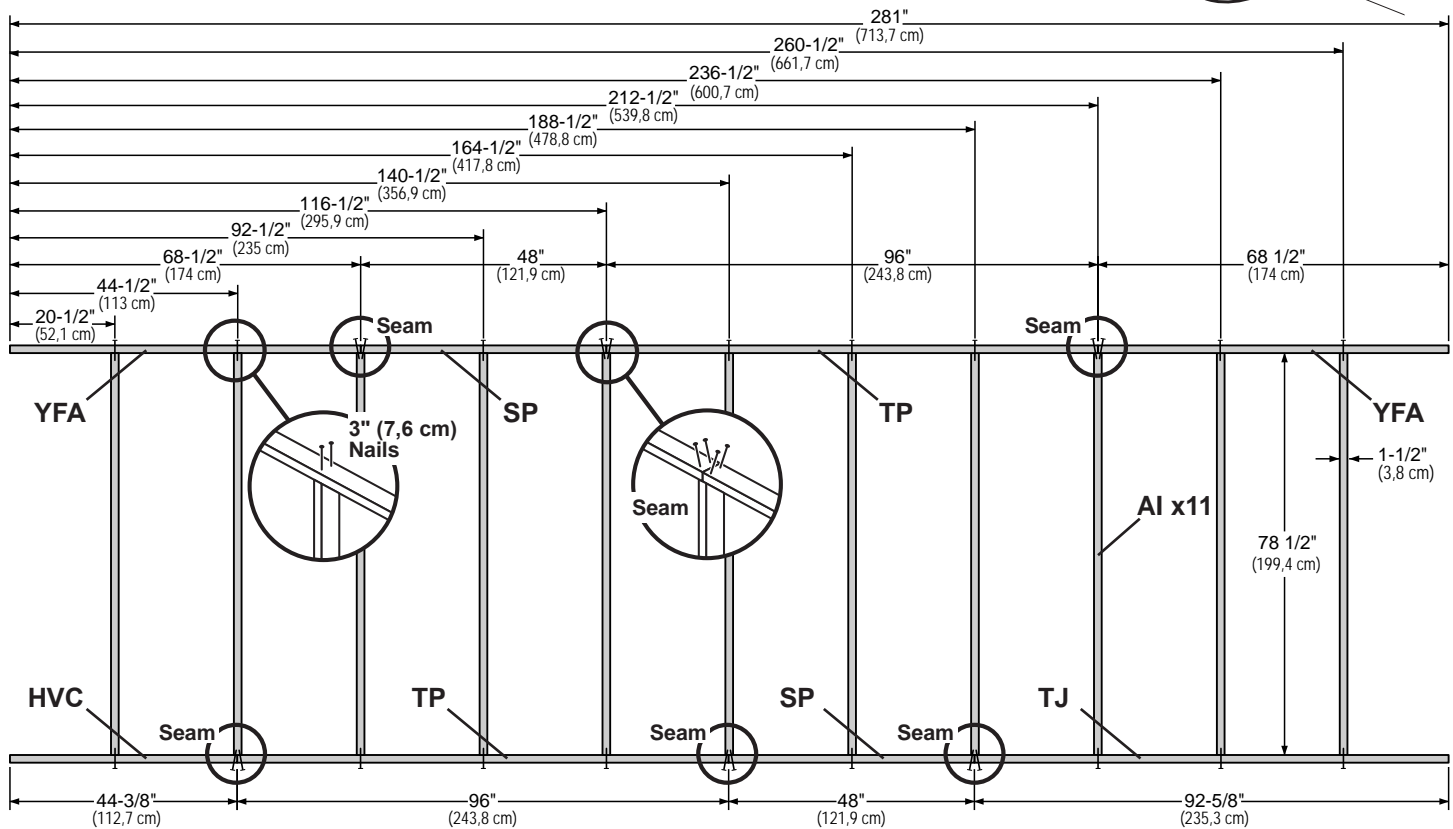
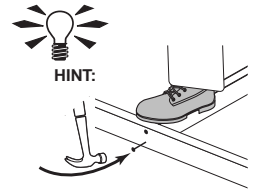

## 24' EAVE WALL 06

### PARTS REQUIRED:

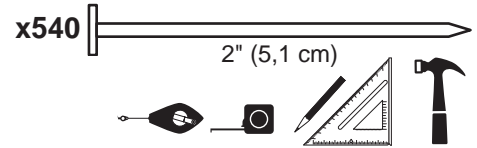
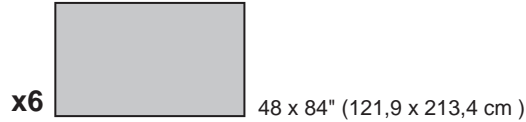

- 2** Install (1) 48" x 84" panel 1-1/2" from the top plate. Use a 2x3 spacer for consistent measurement.

Secure panel with 2" nails spaced 6" apart on edges and 12" inside panel.

*Note the panel lip-edge/square edge orientation.*

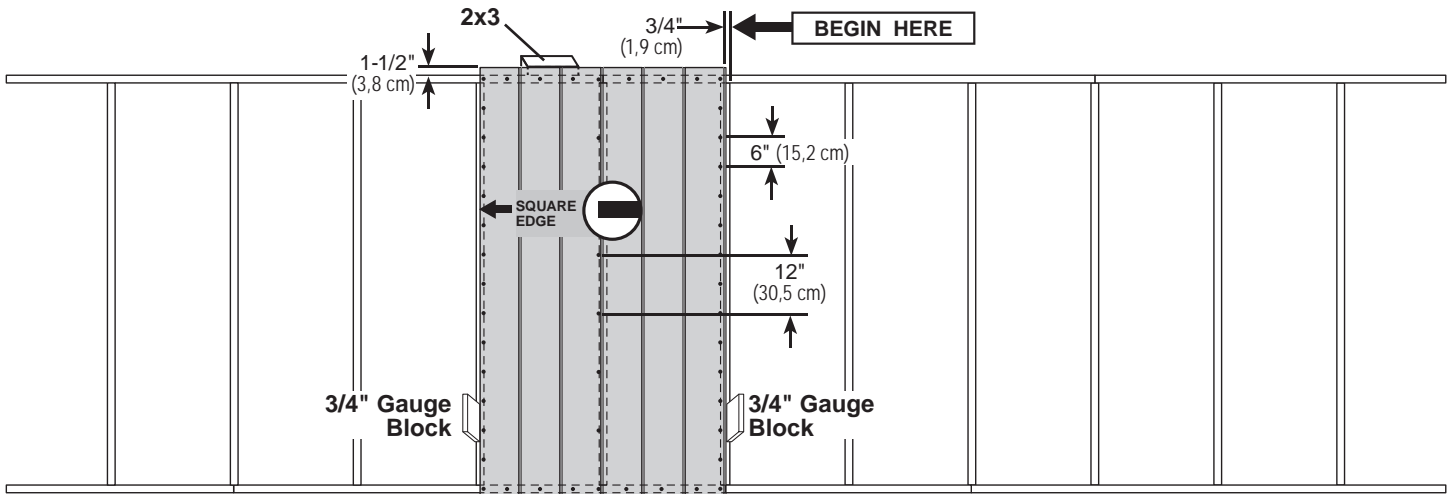

- 3** Install (5) 48" x 84" panels flush to installed panels. Locate panels 1-1/2" from the top plate.

Secure with 2" nails spaced 6" apart on edges and 12" apart inside panel.

*Note the panel lip-edge/square edge orientation.*

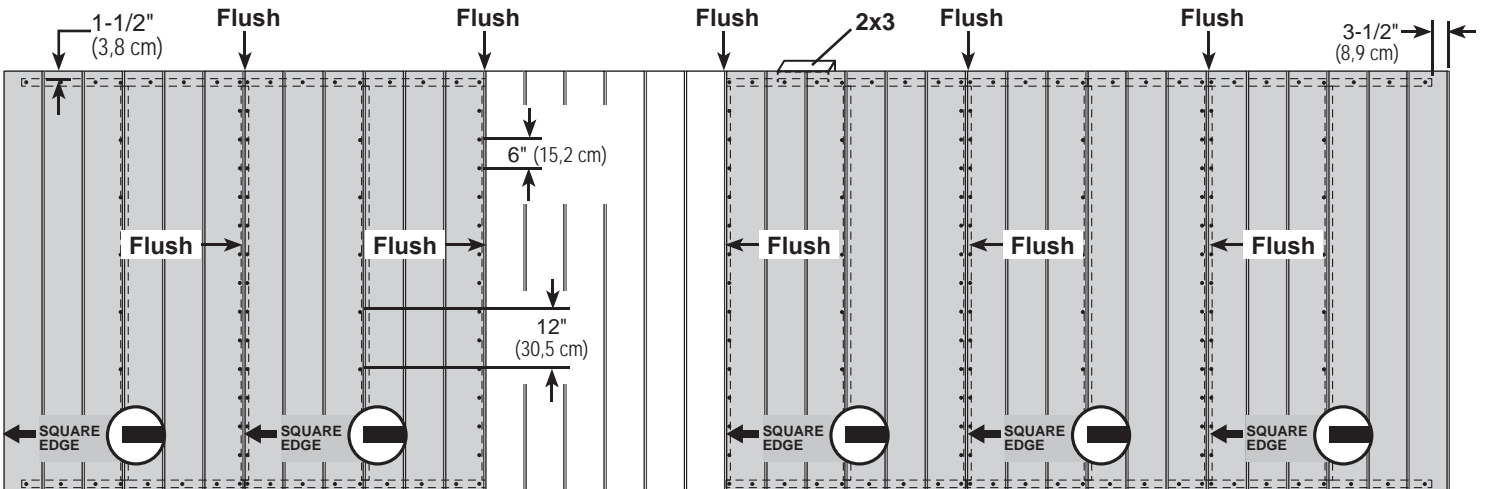

Carefully flip the wall over. Repeat all steps to build the 2nd 24' eave wall.  
Your 24' eave walls are now assembled.

# 12' GABLE WALL 02 INSTALLATION

## PARTS REQUIRED:

x1 **OO**  
69" (175,3 cm) Door Stiffener

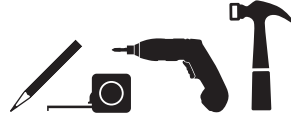

x12 3" (7,6 cm)  
x2 3" (7,6 cm)  
x27 2" (5,1 cm)

### ✓ BEGIN

- Center 12' gable wall on the 144" (365,8 cm) floor dimension. 1-1/2" (3,8 cm) overlap is to the top.

Use **OO** as a temporary brace.  
Secure with (2) 3" screws.

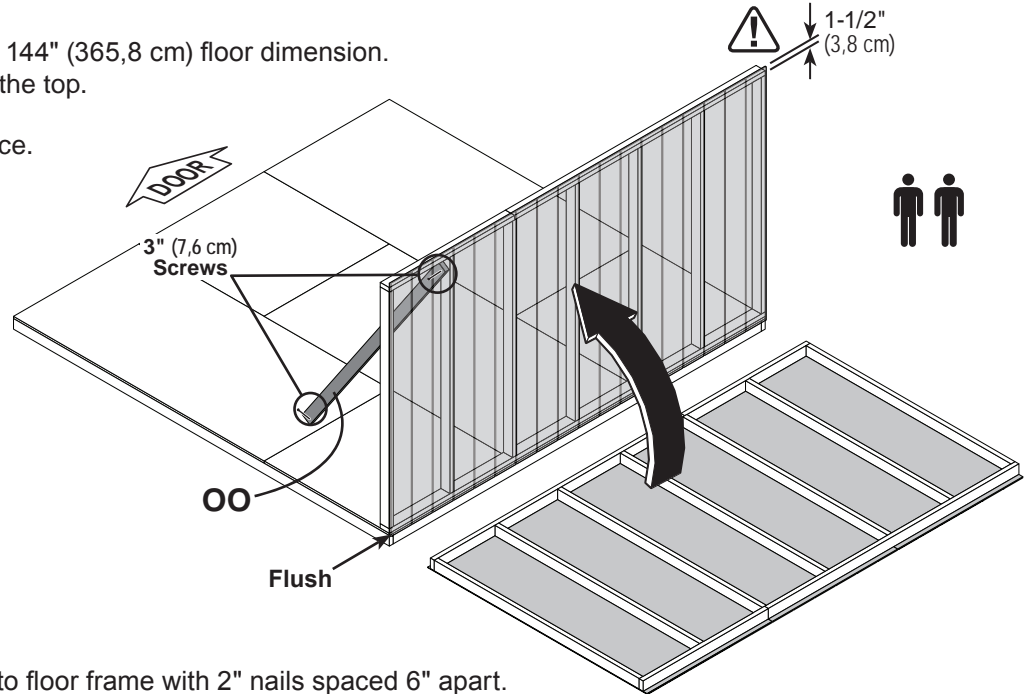

- Secure lower edge of panel to floor frame with 2" nails spaced 6" apart. Angle nails into floor frame (**Fig. A**).

Secure wall bottom plates to floor with 3" nails (**Fig. A**).

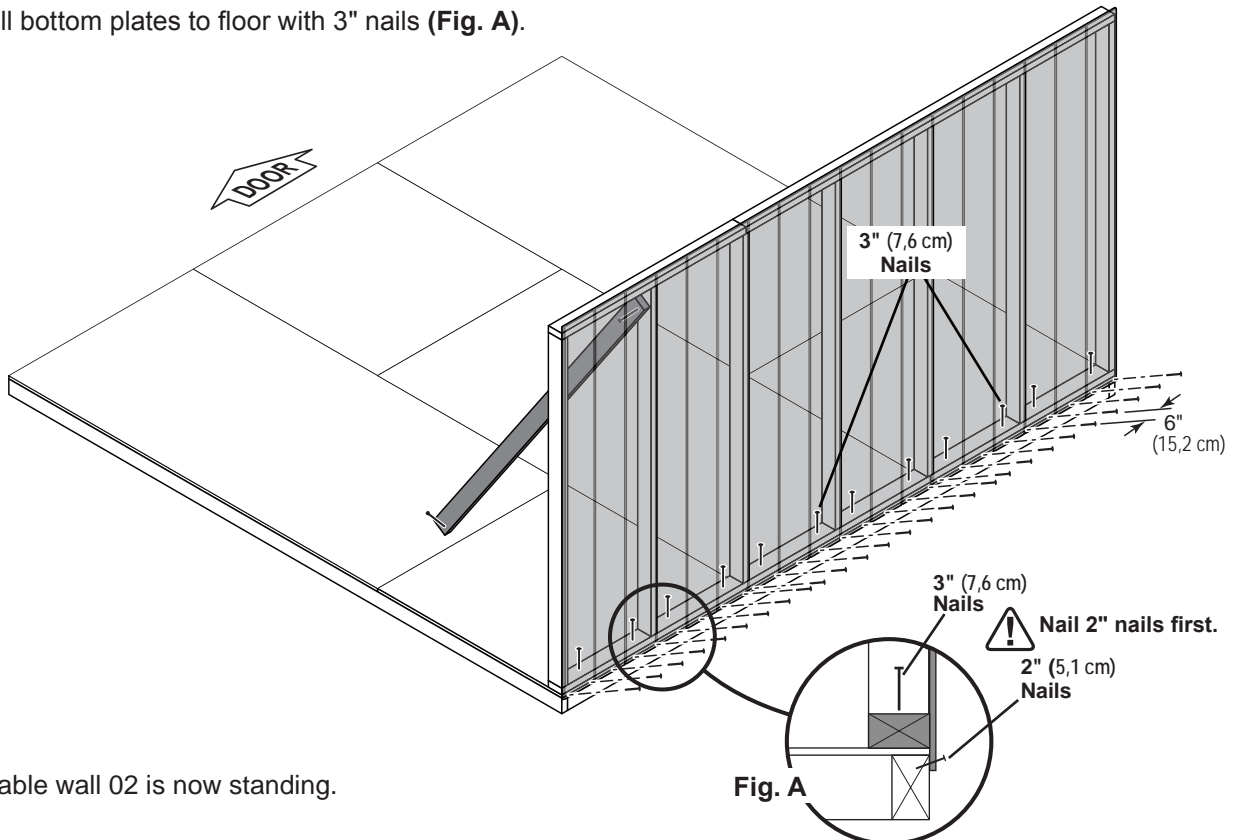

Your 12' gable wall 02 is now standing.

# 1st 12' EAVE WALL INSTALLATION

## PARTS REQUIRED

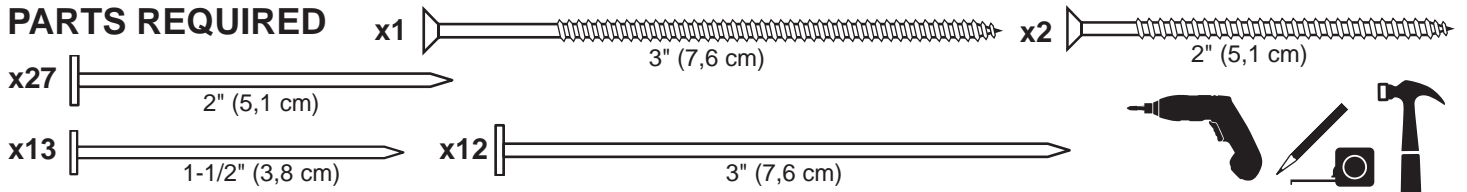

### ✓ BEGIN

- 1 Place 12' eave wall centered on floor. 1-1/2" (3,8 cm) overlap is to the top.

Secure wall with (1) 2" screw into 12' gable wall bottom plate (**Fig. A**) and top plate (**Fig. B**).

**Secure wall to bottom plate first.**

⚠ **ENSURE PANEL CORNERS ARE FLUSH.**

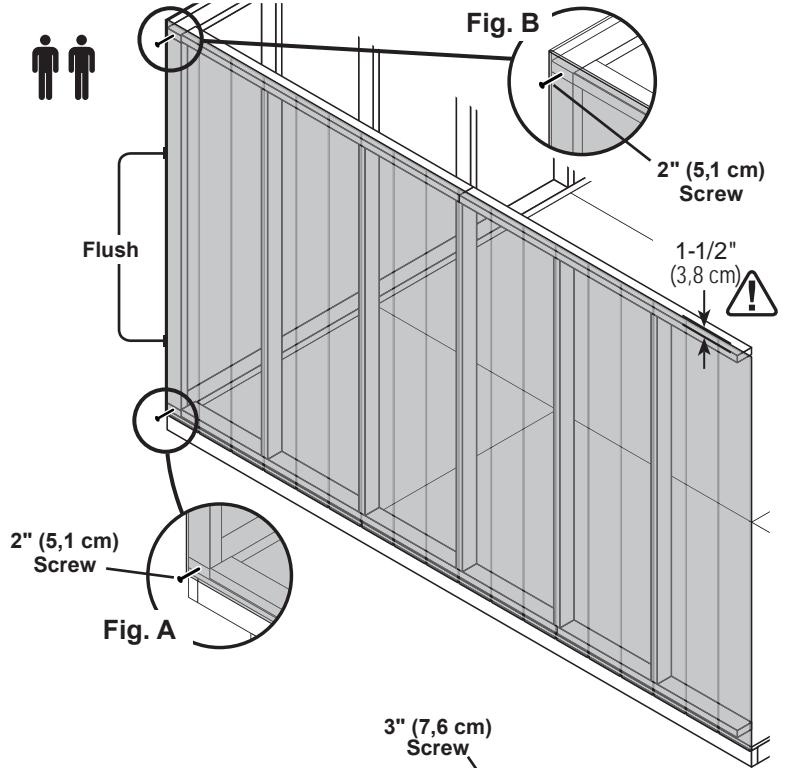

- 2 Nail lower edge of panels to floor with 2" nails spaced 6" apart. Angle nails into floor frame (**Fig. C**).

Nail panel to 12' wall stud with 1-1/2" nails spaced 6" apart.

- 3 Secure wall top plate with (1) 3" screw angled at the corner at an angle as shown (**Fig. D**).

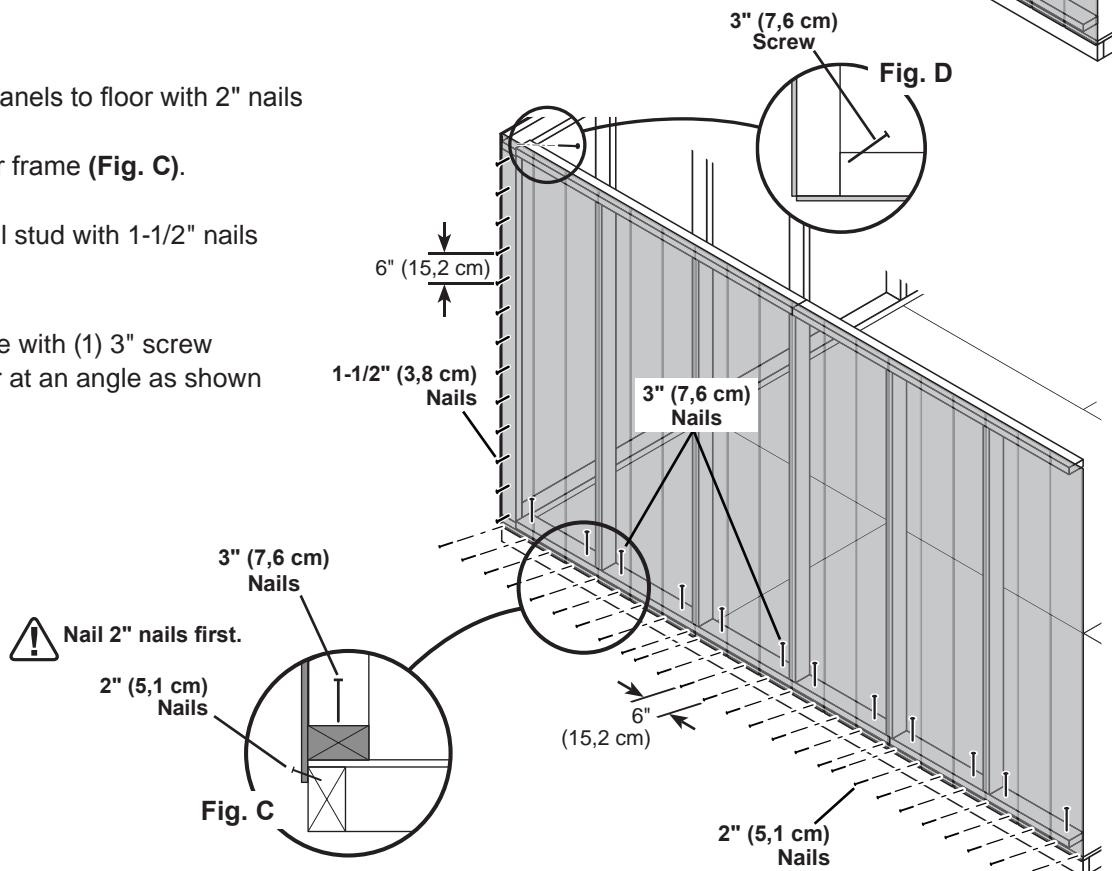

Your 1st 12' eave wall is now installed.

## 2nd 12' EAVE WALL INSTALLATION

### PARTS REQUIRED:

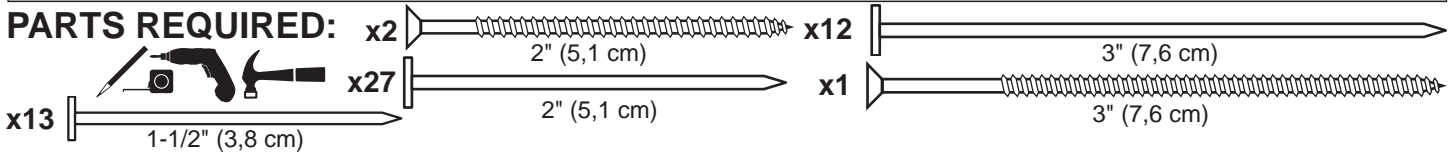

#### ✓ BEGIN

- Place 2nd 12' eave wall centered on floor. 1-1/2" (3,8 cm) overlap is to the top.

#### ⚠ ENSURE PANEL CORNERS ARE FLUSH.

- Secure wall with (1) 2" screw through eave wall panel into 12' gable wall bottom and top plates (**Fig. B, Fig. A**). **Secure wall to bottom plate first.**

- Nail lower edge of wall panels to floor frame with 2" nails spaced 6" apart. Angle nails into floor frame (**Fig. C**).

Secure wall bottom plates to floor with 3" nails (**Fig. C**).

- Nail 12' eave wall panel to 12' gable wall stud with 1-1/2" nails spaced 6" apart.

- Secure wall top plate with (1) 3" screw at the corner at an angle as shown (**Fig. D**).

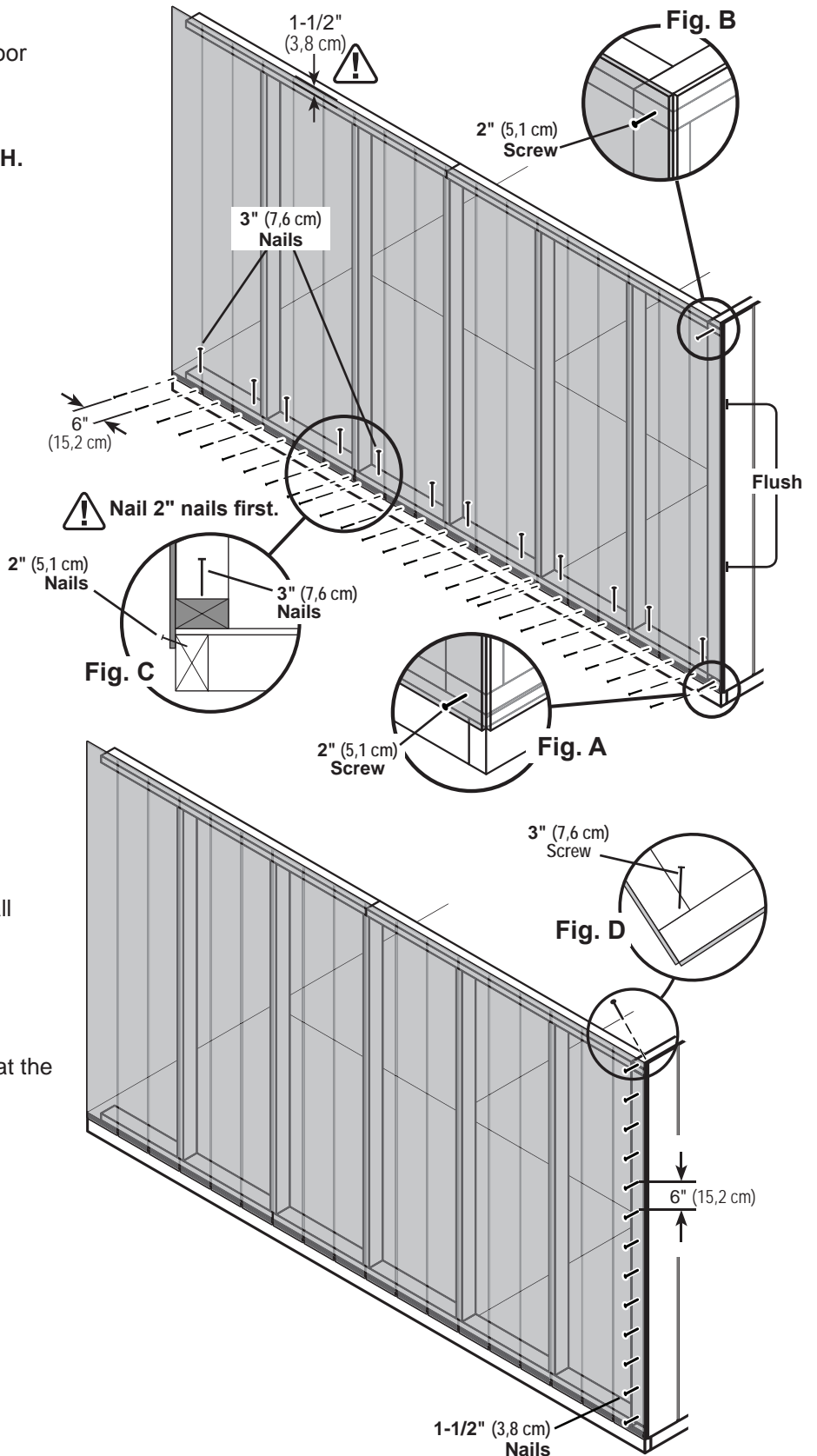

Your 2nd 12' eave wall is now installed.

# 12' GABLE WALL WITH DOOR INSTALLATION

## PARTS REQUIRED

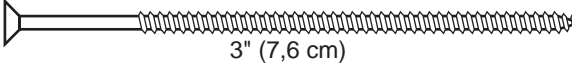
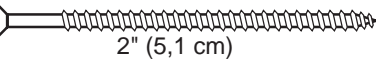
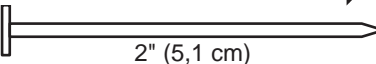
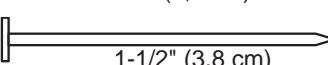
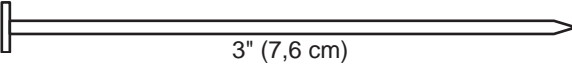
- x2  3" (7,6 cm) x4  2" (5,1 cm)
- x16  2" (5,1 cm)
- x26  1-1/2" (3,8 cm) x8  3" (7,6 cm)

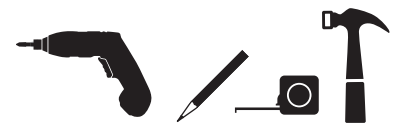

### ✓ BEGIN



**1** Place 12' gable wall on floor, centered between installed walls.

Secure wall with 2" screws into top and bottom plates (Fig. A, Fig. B).

*Secure wall to bottom plate first.*

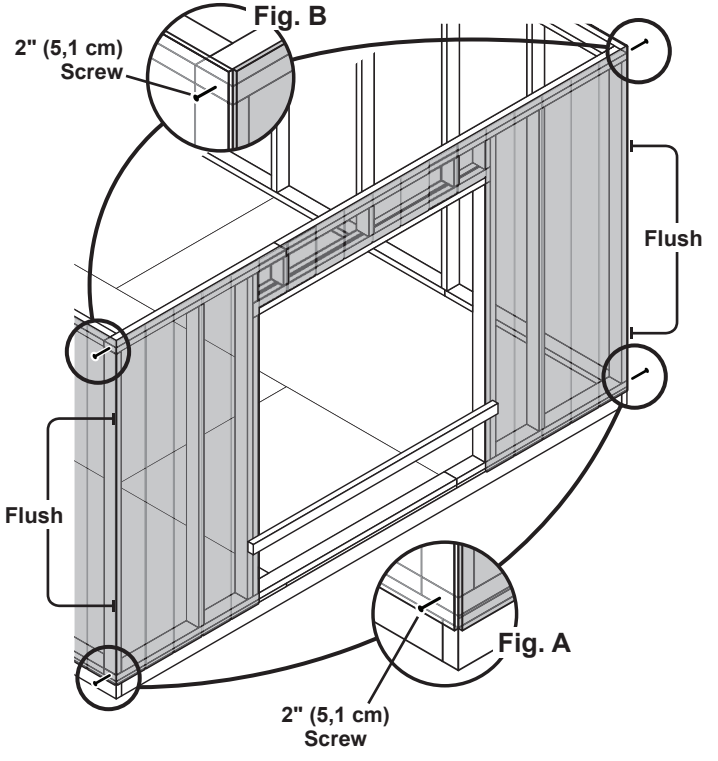

**⚠ ENSURE PANEL CORNERS ARE FLUSH. ⚠**

**2** Nail lower edge of panels to floor with 2" nails spaced 6" apart. Angle nails into floor frame (Fig. C).

Nail panels to 24' wall studs with 1-1/2" nails spaced 6" apart.

**3** Secure wall top plates with 3" screws at each corner at an angle (Fig. D).

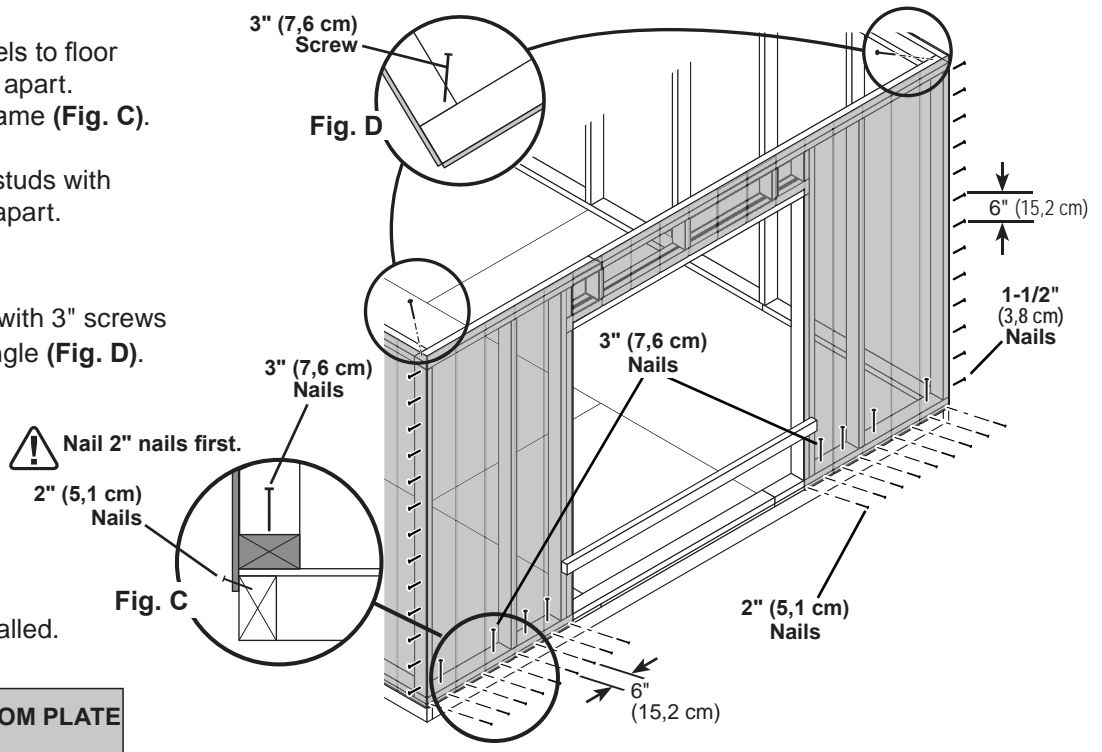

**FINISH**  
Your walls are now installed.

**CUT OUT AND REMOVE BOTTOM PLATE AT DOOR OPENING.  
REMOVE TEMPORARY BRACING.**

# 12' x 12' WALL DOUBLERS INSTALLATION

## PARTS REQUIRED:

- x2 **SP** 2 x 4 x 48" (5,1 x 10,2 x 121,9 cm)      x2 **HVC** 2 x 4 x 44-3/8" (5,1 x 10,2 x 112,7 cm)
- x2 **TJ** 2 x 4 x 92-5/8" (5,1 x 10,2 x 235 cm)
- x2 **PT** 2 x 4 x 96" (5,1 x 10,2 x 243,8 cm)

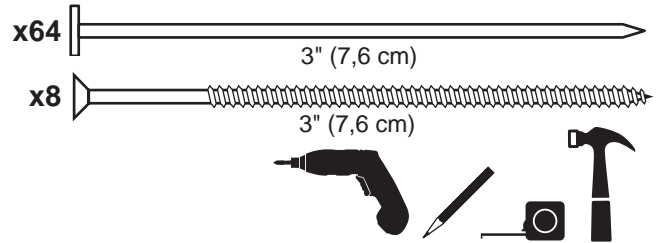

### ✓ BEGIN

- 1 Orient parts on top of wall frames. Measure and mark from end of boards. Secure from top with (2) 3" nails spaced every 24" (Fig. A).
- 2 Secure from bottom with (2) 3" screws at each corner (Fig. B).

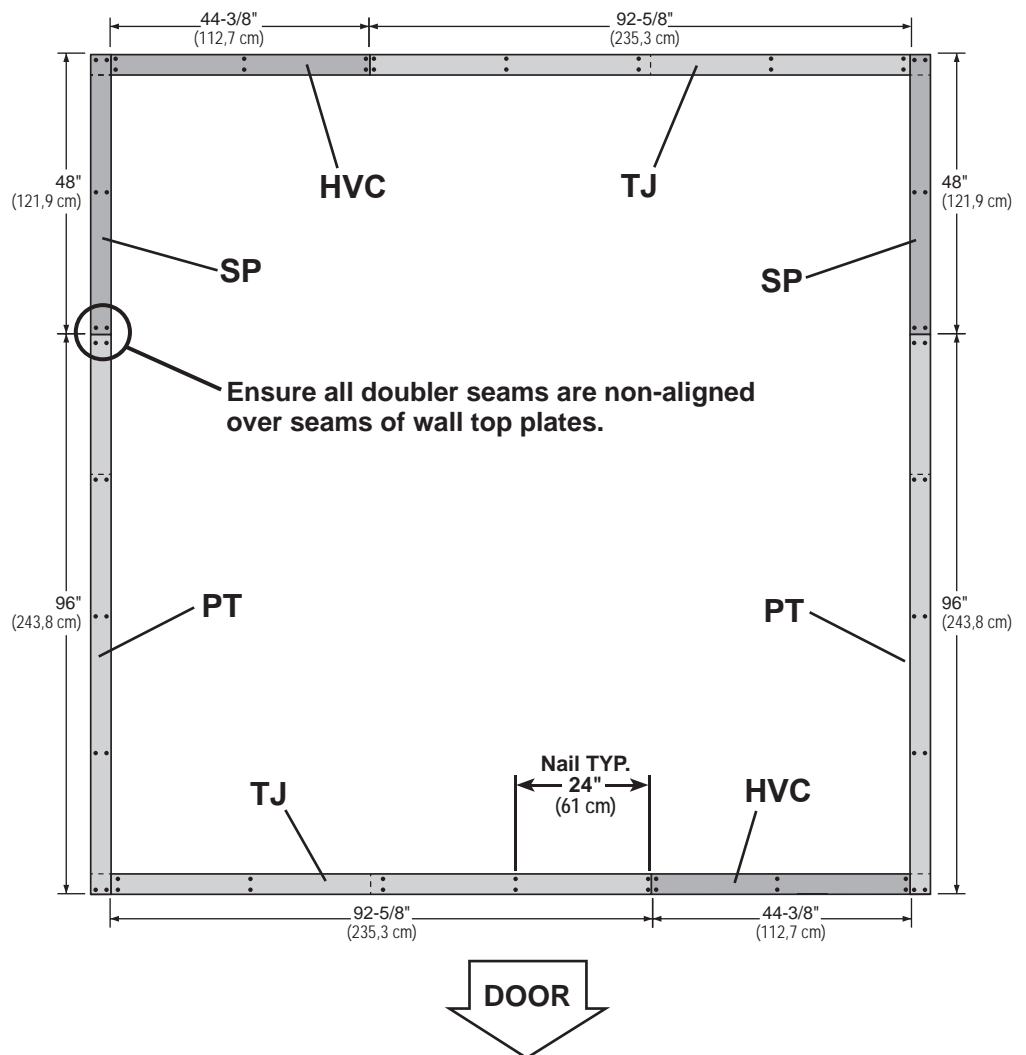
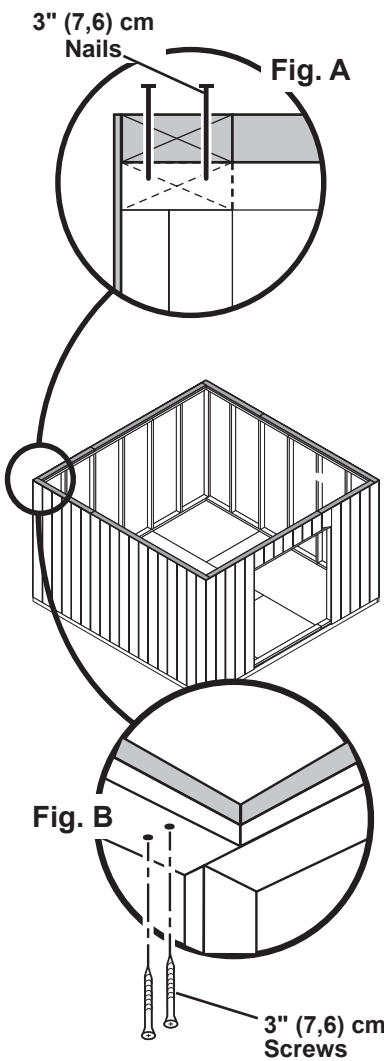

Your wall doublers are now installed.

CONTINUE TO PAGE 51 TO RESUME CONSTRUCTION OF 12' X 12' SHED.

# 12' GABLE WALL 02 INSTALLATION

## PARTS REQUIRED:

x1 **OO**  
69" (175,3 cm) Door Stiffener



x12 3" (7,6 cm)  
x2 3" (7,6 cm)  
x27 2" (5,1 cm)

### ✓ BEGIN

- Center 12' wall on the 120" (304,8 cm) floor dimension. 1-1/2" (3,8 cm) overlap is to the top.

Use **OO** as a temporary brace.  
Secure with (2) 3" screws.

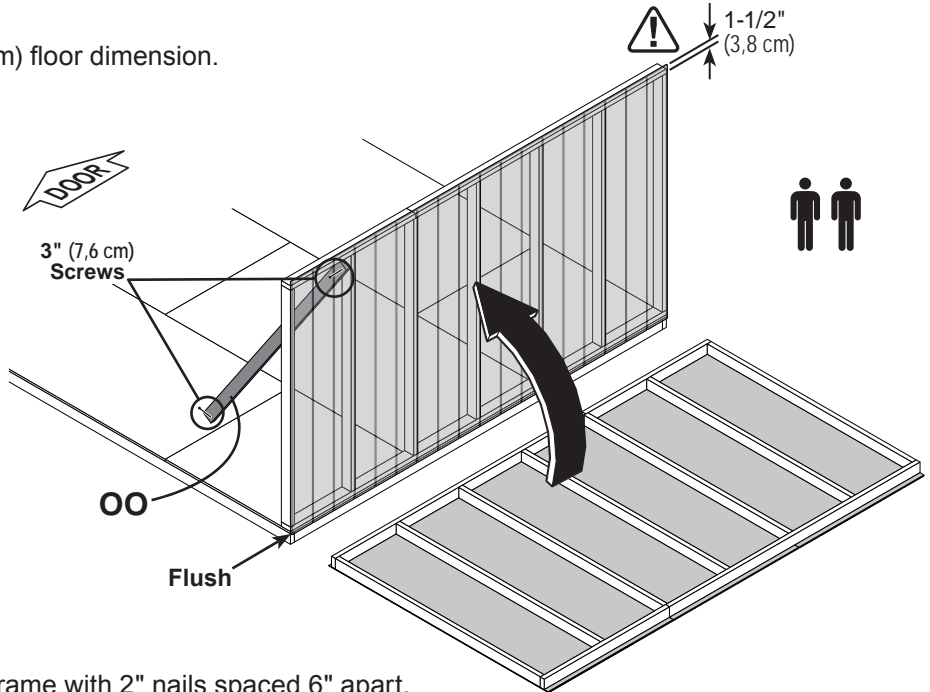

- Secure lower edge of panel to floor frame with 2" nails spaced 6" apart. Angle nails into floor frame (**Fig. A**).

Secure wall bottom plates to floor with 3" nails (**Fig. A**).

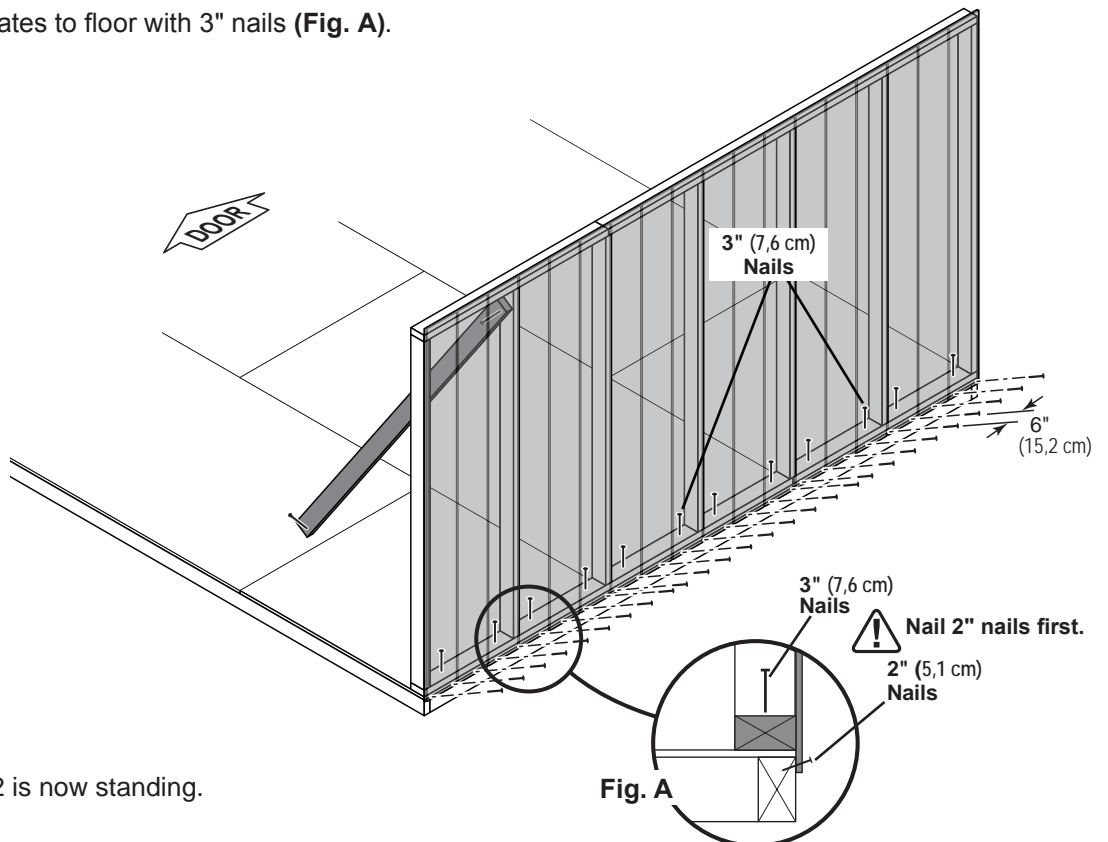

Your 12' gable wall 02 is now standing.

# 1st 16' EAVE WALL INSTALLATION

## PARTS REQUIRED

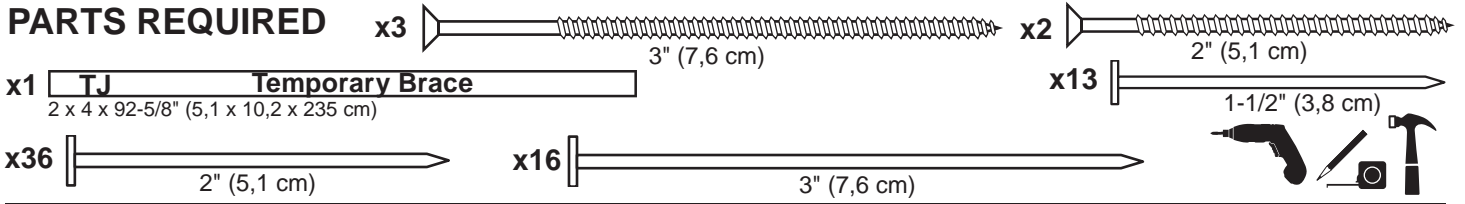

### ✓ BEGIN 1

Place 1st 16' eave wall centered on floor. The 1-1/2" (3,8 cm) overlap is to the top. Use **TJ** as a temporary brace as shown. Secure **TJ** with (2) 3" screws.

Secure wall with (1) 2" screw into 12' wall bottom plate (**Fig. A**) and top plate (**Fig. B**).

**Secure wall to bottom plate first.**

**⚠ ENSURE PANEL CORNERS ARE FLUSH.**

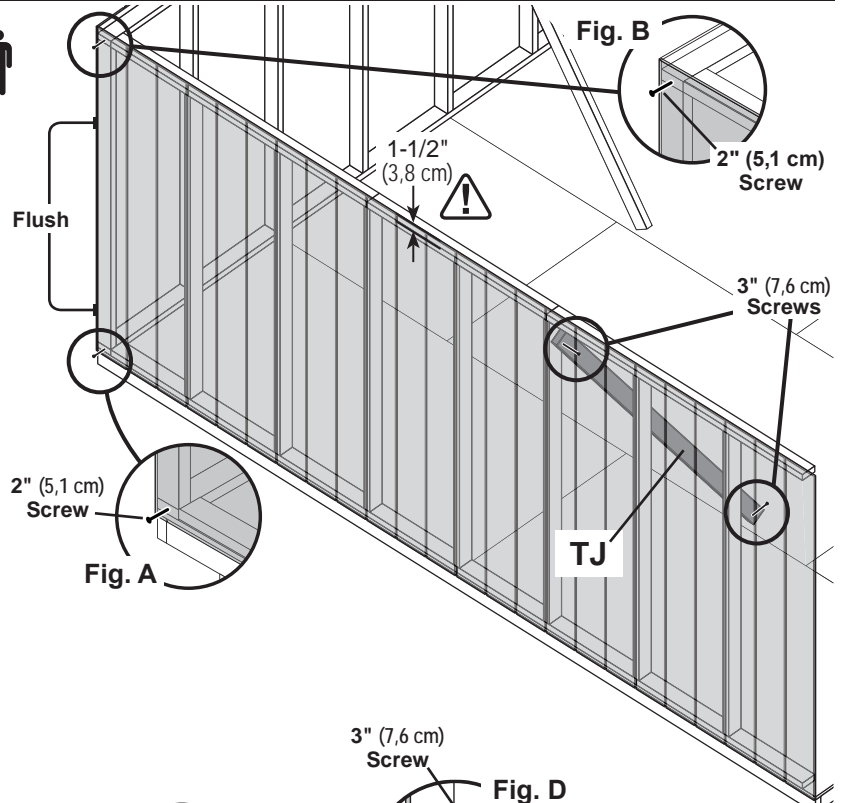

### 2

Nail lower edge of panels to floor with 2" nails spaced 6" apart. Angle nails into floor frame (**Fig. C**).

Nail panel to 12' wall stud with 1-1/2" nails spaced 6" apart.

### 3

Secure wall top plate with (1) 3" screw at the corner at an angle as shown (**Fig. D**).

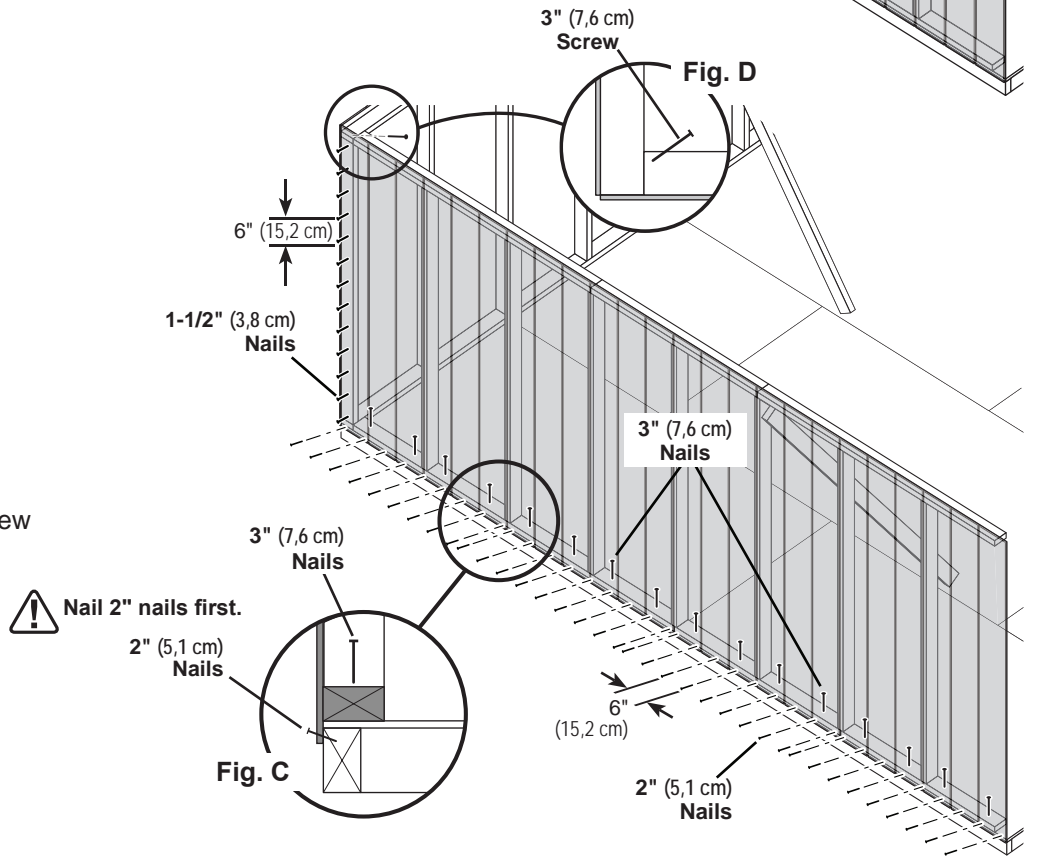

Your 1st 16' eave wall is now installed.

## 2nd 16' EAVE WALL INSTALLATION

### PARTS REQUIRED:

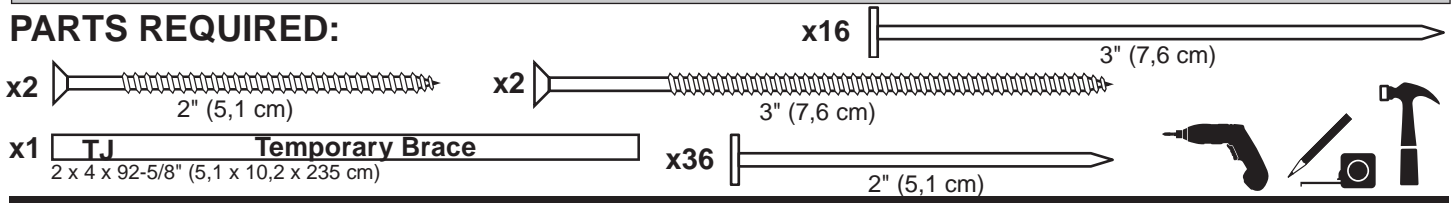

**✓ BEGIN**  
**1**



Place 2nd 16' wall centered on floor.  
The 1-1/2" (3,8 cm) overlap is to the top.

Use **TJ** as a temporary brace as shown.  
Secure **TJ** with (2) 3" screws.

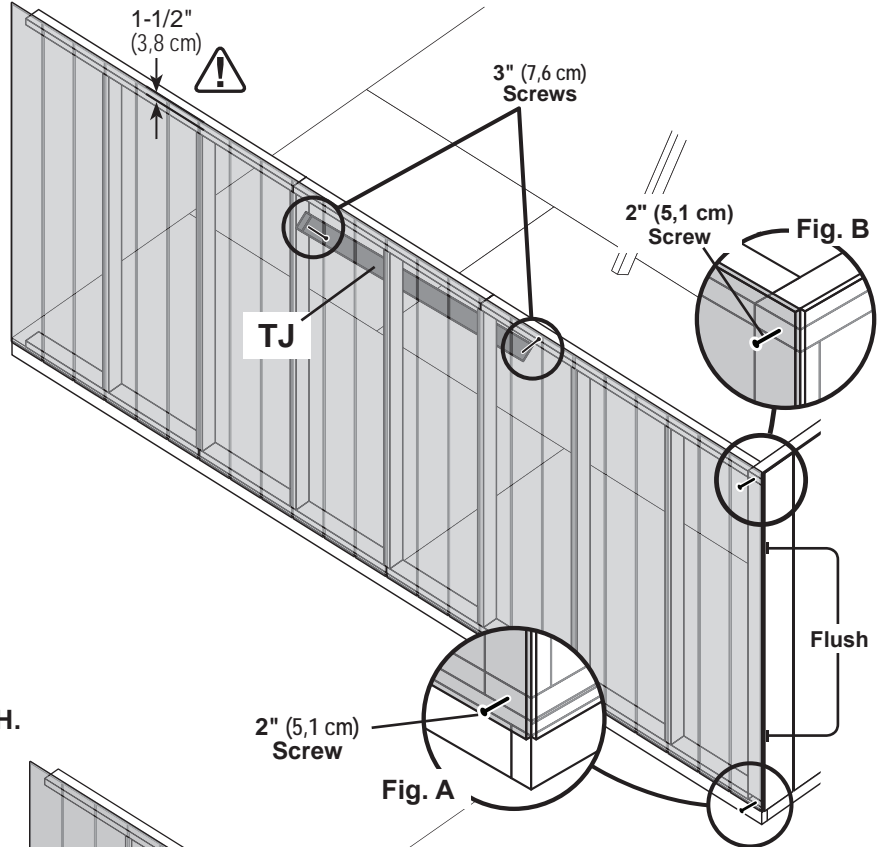

**2**

Secure wall with (1) 2" screw through gable wall panel into 12' wall bottom and top plates (**Fig. A, Fig. B**).

*Secure wall to bottom plate first.*

**⚠ ENSURE PANEL CORNERS ARE FLUSH.**

**3**

Nail lower edge of wall panels to floor frame with 2" nails spaced 6" apart.  
Angle nails into floor frame (**Fig. C**).

Secure wall bottom plates to floor with 3" nails (**Fig. C**).

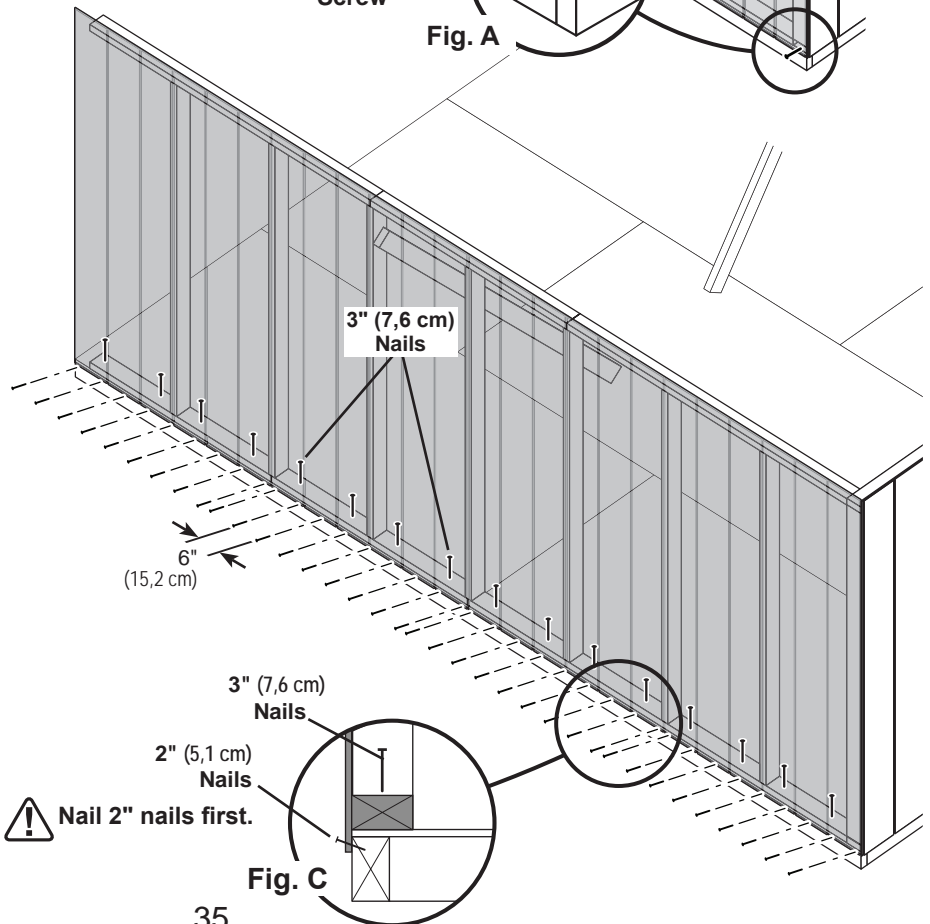

## 2nd 16' EAVE WALL INSTALLATION

### PARTS REQUIRED:

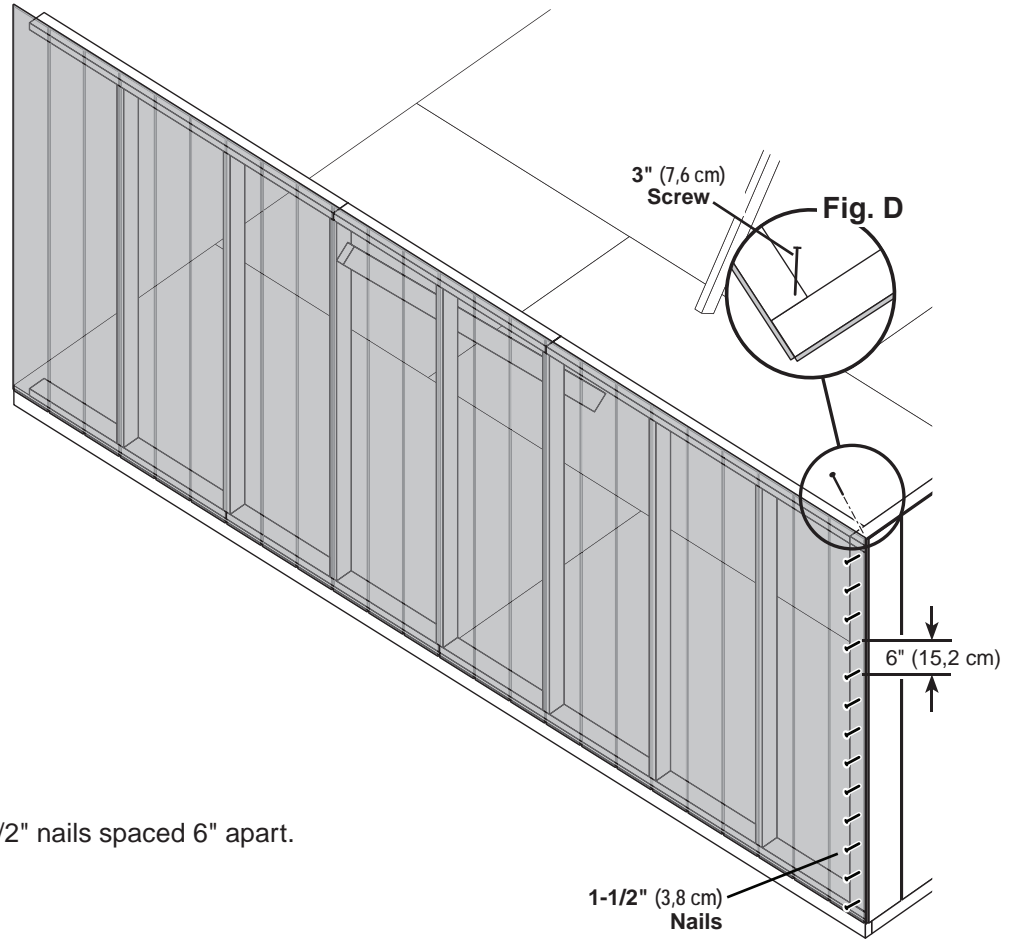
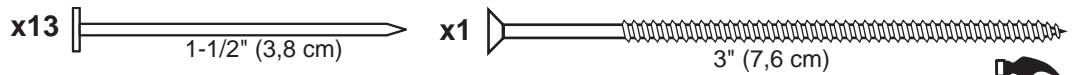

4

Nail 16' wall panel to 12' wall stud with 1-1/2" nails spaced 6" apart.

5

Secure gable wall top plate with (1) 3" screw at the corner at an angle, as shown (**Fig. D**).



Your 2nd 16' wall is now installed.

# 12' GABLE WALL WITH DOOR INSTALLATION

## PARTS REQUIRED

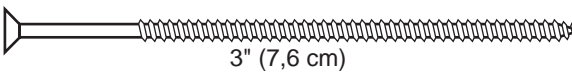
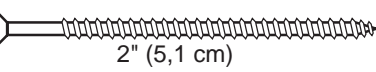
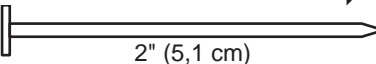
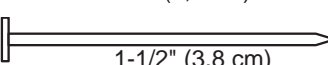
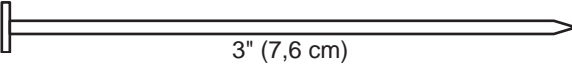
- x2  3" (7,6 cm) x4  2" (5,1 cm)
- x16  2" (5,1 cm)
- x26  1-1/2" (3,8 cm) x8  3" (7,6 cm)

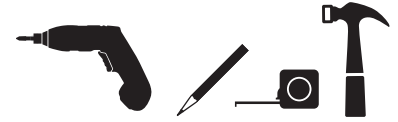

### ✓ BEGIN



- 1 Place 12' gable wall on floor, centered between installed walls.

Secure wall with 2" screws into top and bottom plates (Fig. A, Fig. B).

*Secure wall to bottom plate first.*

**⚠ ENSURE PANEL CORNERS ARE FLUSH. ⚠**

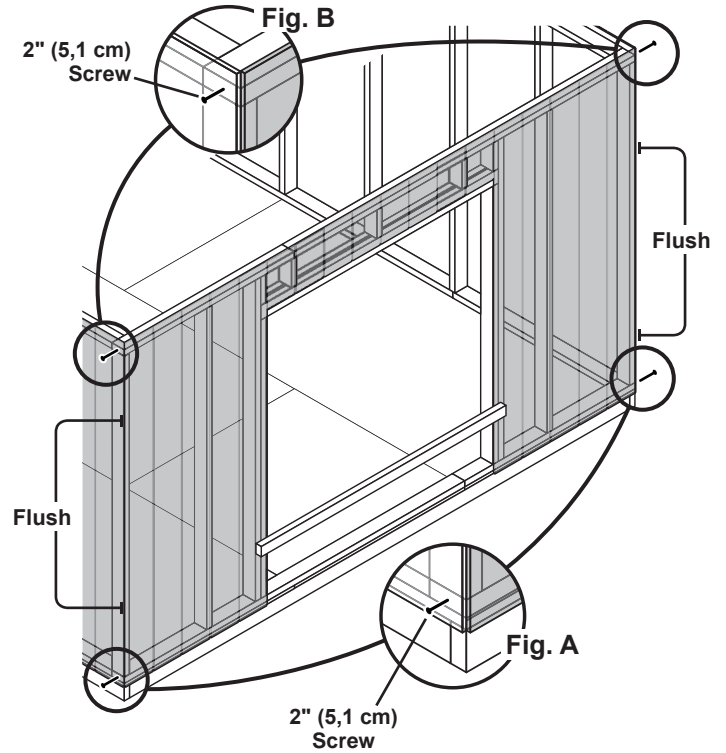

- 2 Nail lower edge of panels to floor with 2" nails spaced 6" apart. Angle nails into floor frame (Fig. C).

Nail panels to 24' wall studs with 1-1/2" nails spaced 6" apart.

- 3 Secure wall top plates with 3" screws at each corner at an angle (Fig. D).

**⚠ Nail 2" nails first.**  
2" (5,1 cm) Nails

Fig. C

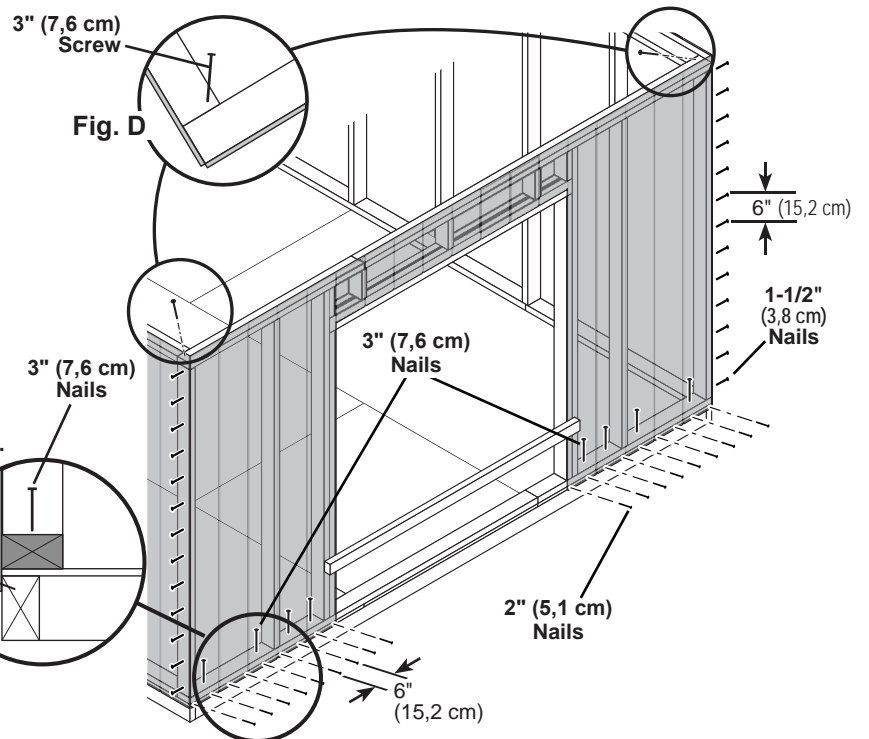

### FINISH



Your walls are now installed.

**CUT OUT AND REMOVE BOTTOM PLATE AT DOOR OPENING.  
REMOVE TEMPORARY BRACING.**

# 12' x 16' WALL DOUBLERS INSTALLATION

## PARTS REQUIRED:

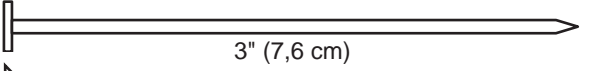
- x4 **NK**  
2 x 4 x 48" (5,1 x 10,2 x 121,9 cm)
- x2 **HVC**  
2 x 4 x 44-3/8" (5,1 x 10,2 x 112,7 cm)
- x2 **TJ**  
2 x 4 x 92-5/8" (5,1 x 10,2 x 235 cm)
- x2 **PT**  
2 x 4 x 96" (5,1 x 10,2 x 243,8 cm)

- x76  3" (7,6 cm)
- x8  3" (7,6 cm)



### BEGIN

- 1 Orient parts on top of wall frames. Measure and mark from end of boards. Secure from top with (2) 3" nails spaced every 24" (**Fig. A**).
- 2 Secure from bottom with (2) 3" screws at each corner (**Fig. B**).

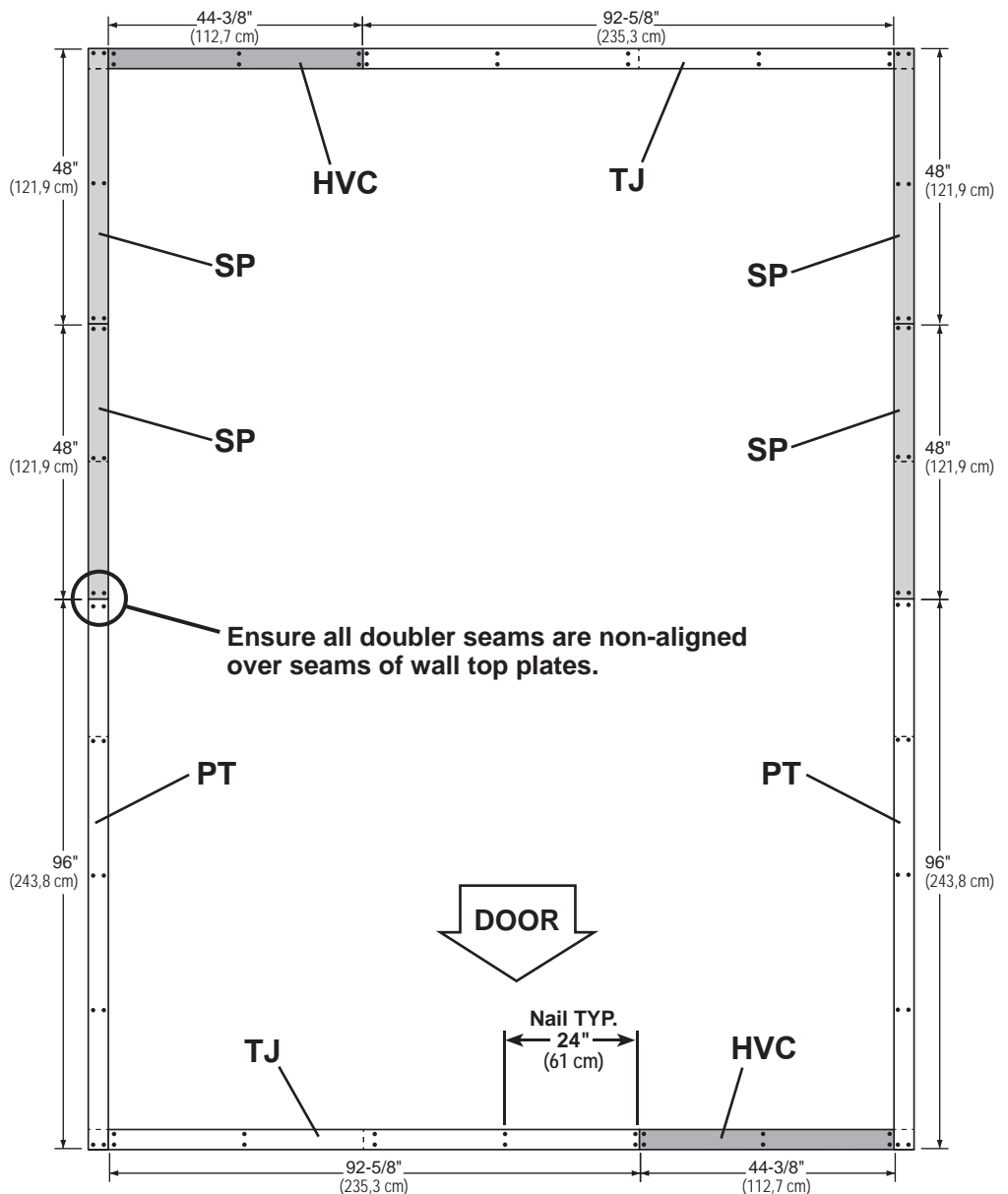
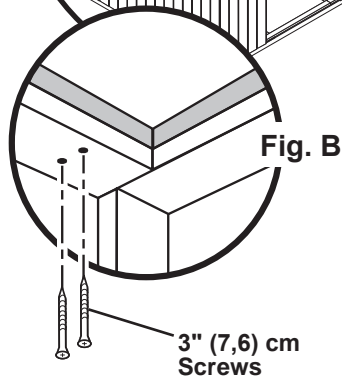
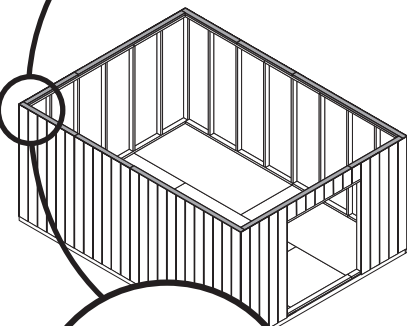
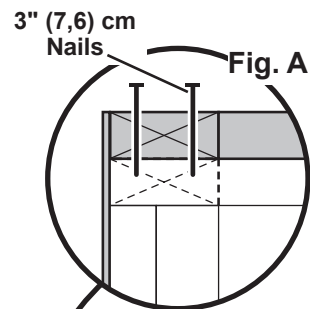

Your wall doublers are now installed.

CONTINUE TO PAGE 51 TO RESUME CONSTRUCTION OF 12' X 16' SHED.

# 12' GABLE WALL 02 INSTALLATION

## PARTS REQUIRED:

x1 **OO**  
69" (175,3 cm) Door Stiffener



x12 3" (7,6 cm)  
x2 3" (7,6 cm)  
x27 2" (5,1 cm)

### ✓ BEGIN

- Center 12' wall on the 120" (304,8 cm) floor dimension. 1-1/2" (3,8 cm) overlap is to the top.

Use **OO** as a temporary brace.  
Secure with (2) 3" screws.

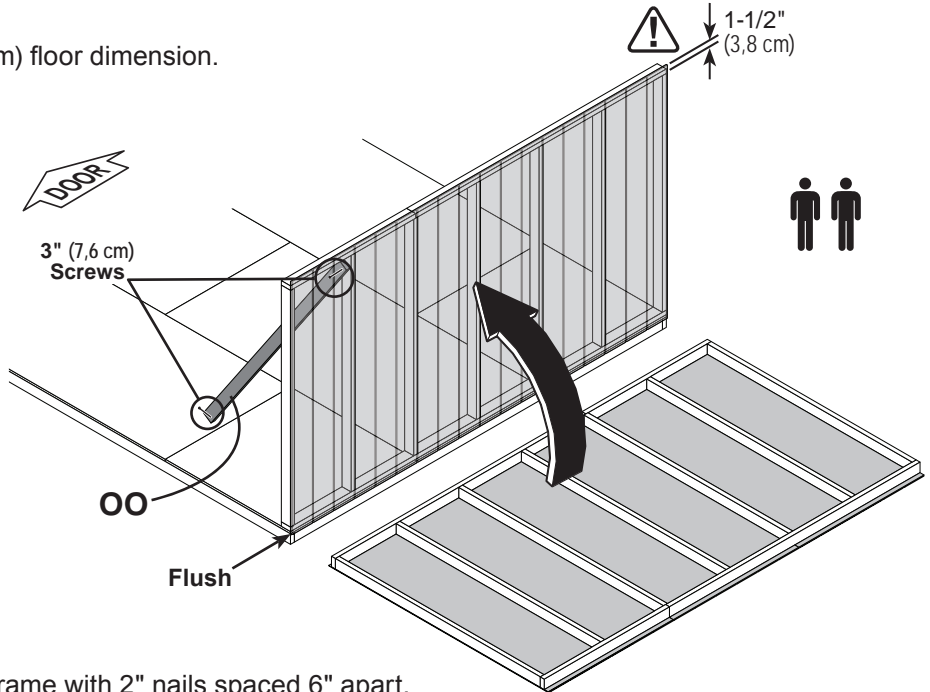

- Secure lower edge of panel to floor frame with 2" nails spaced 6" apart. Angle nails into floor frame (**Fig. A**).

Secure wall bottom plates to floor with 3" nails (**Fig. A**).

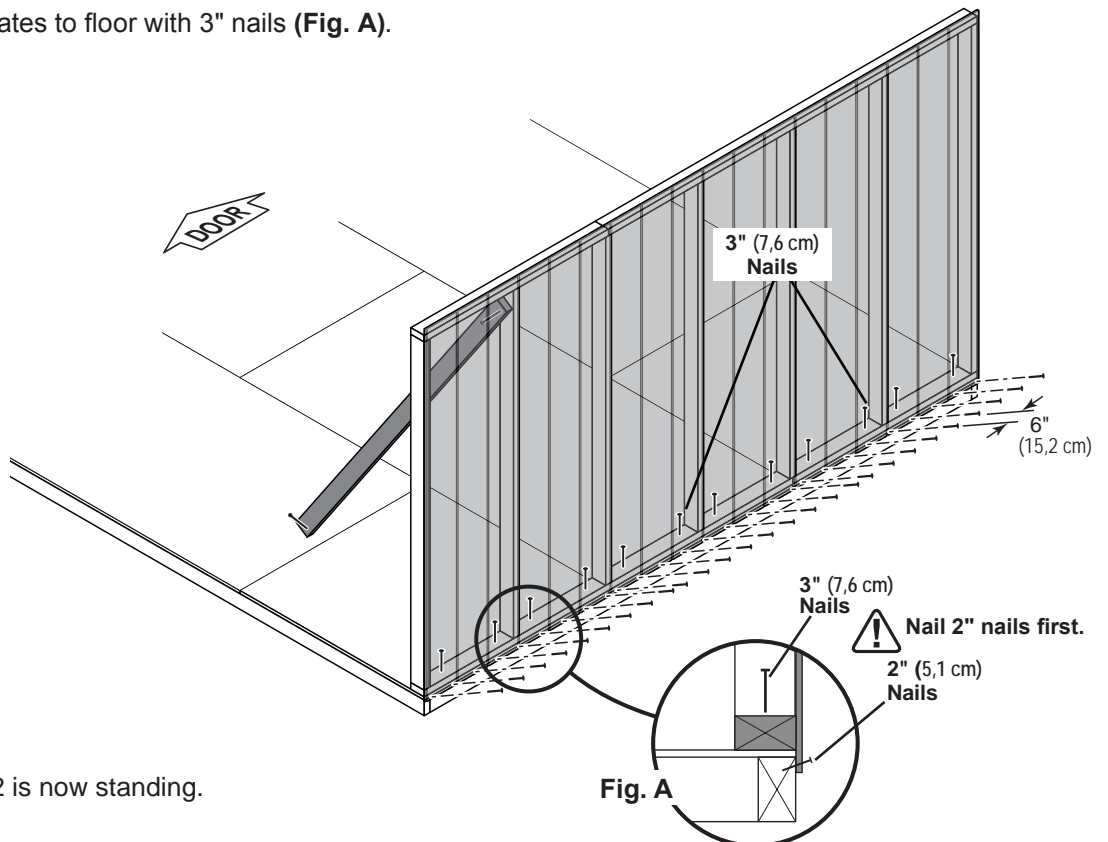

Your 12' gable wall 02 is now standing.

# 1st 20' EAVE WALL INSTALLATION

## PARTS REQUIRED

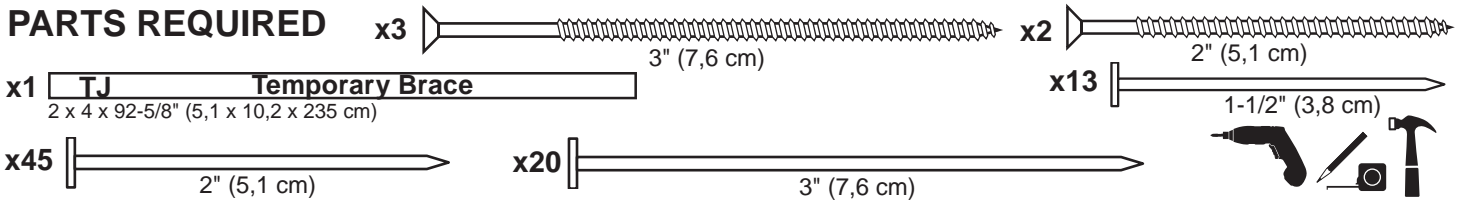

### ✓ BEGIN 1



Place 1st 20' eave wall centered on floor.  
 The 1-1/2" (3,8 cm) overlap is to the top.  
 Use **TJ** as a temporary brace as shown.  
 Secure **TJ** with (2) 3" screws.

Secure wall with (1) 2" screw into 12' wall bottom plate (**Fig. A**) and top plate (**Fig. B**).

*Secure wall to bottom plate first.*

⚠ ENSURE PANEL CORNERS ARE FLUSH.

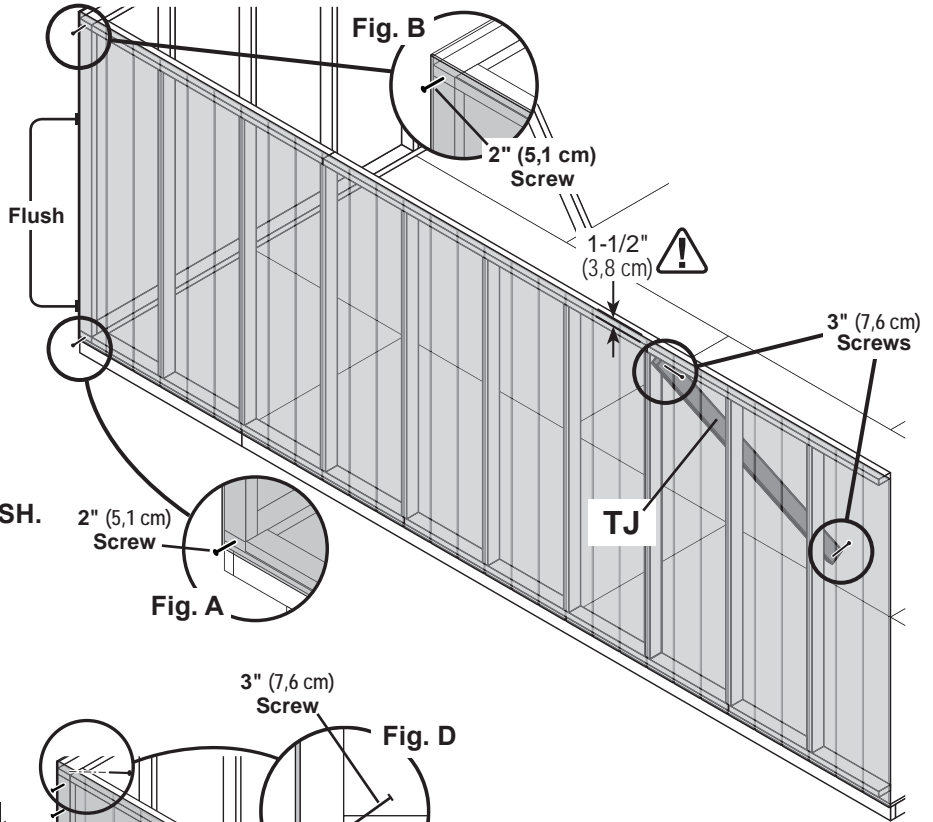

### 2

Nail lower edge of panels to floor with 2" nails spaced 6" apart.  
 Angle nails into floor frame (**Fig. C**).

Secure panel to 12' wall stud with 1-1/2" nails spaced 6" apart.

### 3

Secure wall top plate with (1) 3" screw at the corner at an angle as shown (**Fig. D**).

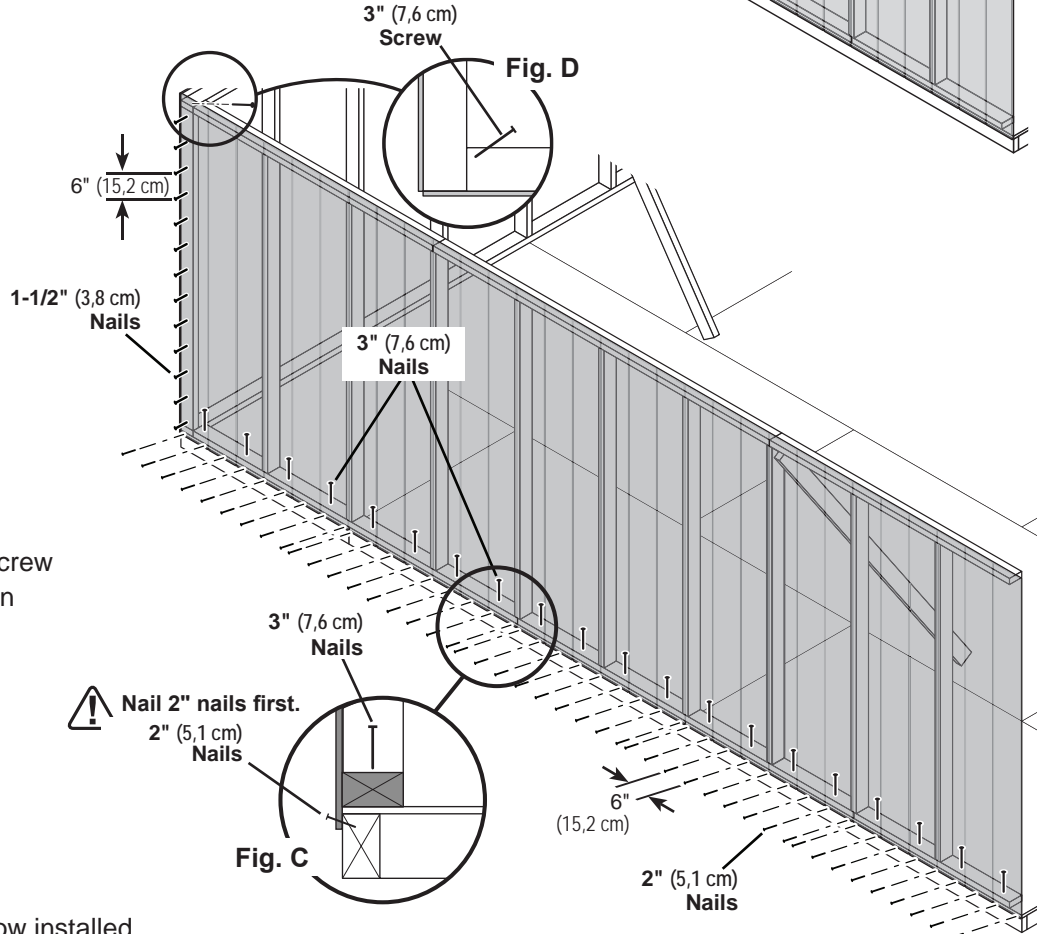

Your 1st 20' eave wall is now installed.

## 2nd 20' EAVE WALL INSTALLATION

**PARTS REQUIRED:**

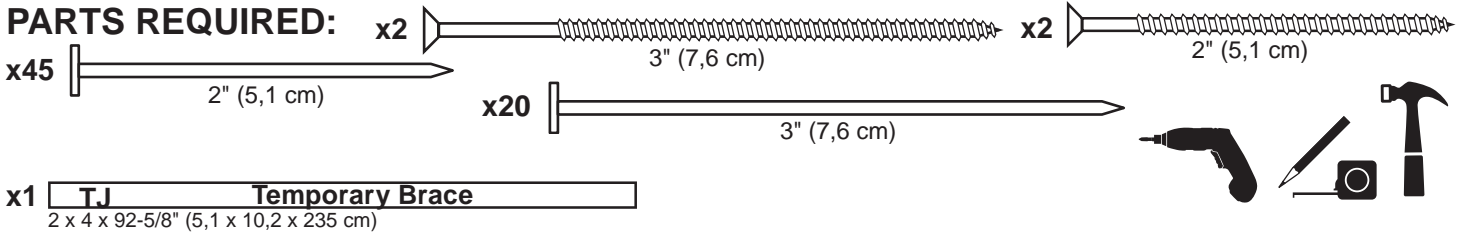

**✓ BEGIN**  
**1**



Place 2nd 20' wall centered on floor.  
1-1/2" (3,8 cm) overlap is to the top.

Use **TJ** as a temporary brace as shown.  
Secure **TJ** with (2) 3" screws.

**2**

Secure wall with (1) 2" screw through gable wall panel into 12' wall bottom and top plates (**Fig. A, Fig. B**).

*Secure wall to bottom plate first.*

**⚠ ENSURE PANEL CORNERS ARE FLUSH.**

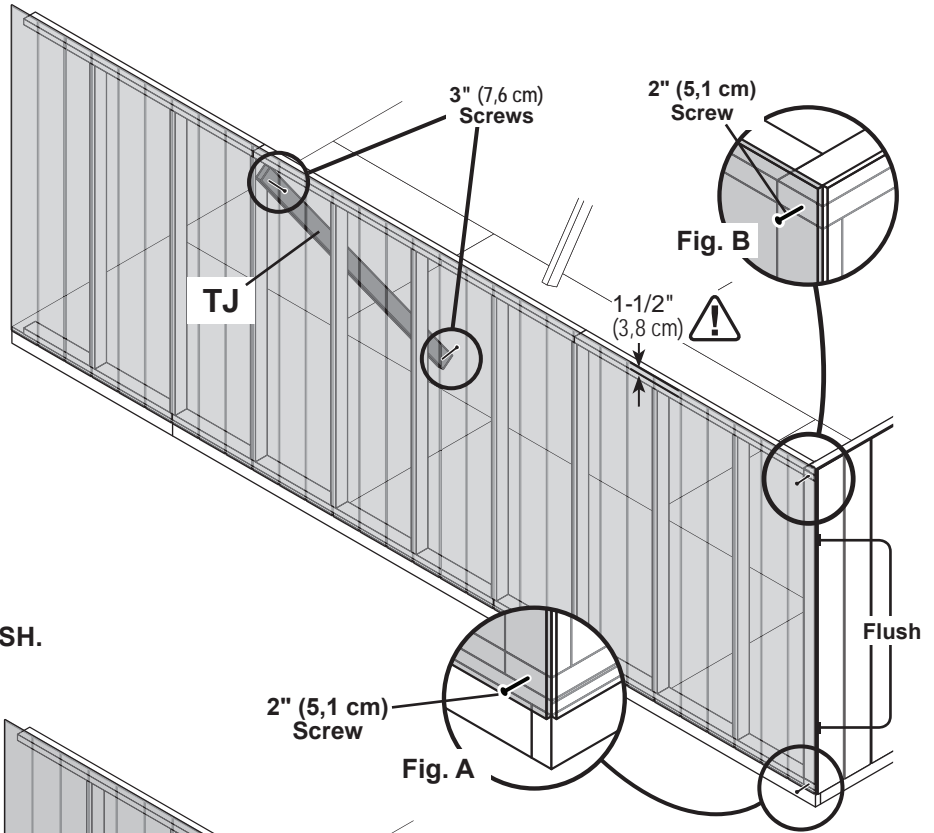

**3**

Nail lower edge of wall panels to floor frame with 2" nails spaced 6" apart.  
Angle nails into floor frame (**Fig. C**).

Secure wall bottom plates to floor with 3" nails (**Fig. C**).

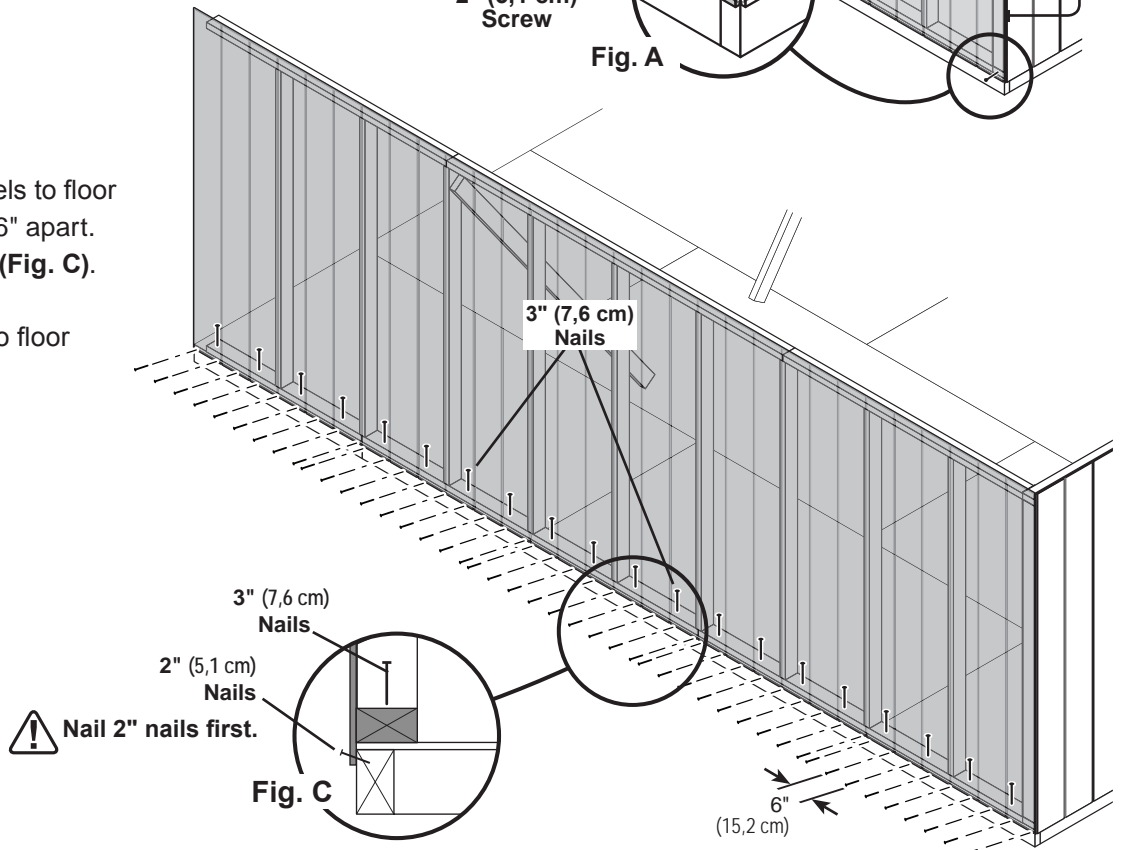

## 2nd 20' EAVE WALL INSTALLATION

### PARTS REQUIRED:

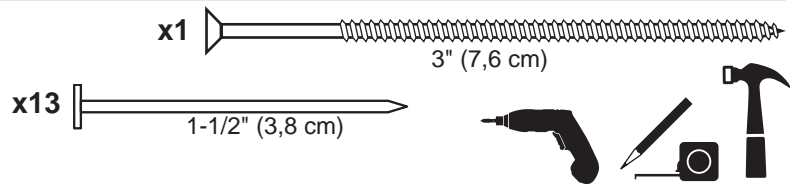

4

Secure 20' wall panel to 12' wall stud with 1-1/2" nails spaced 6" apart.

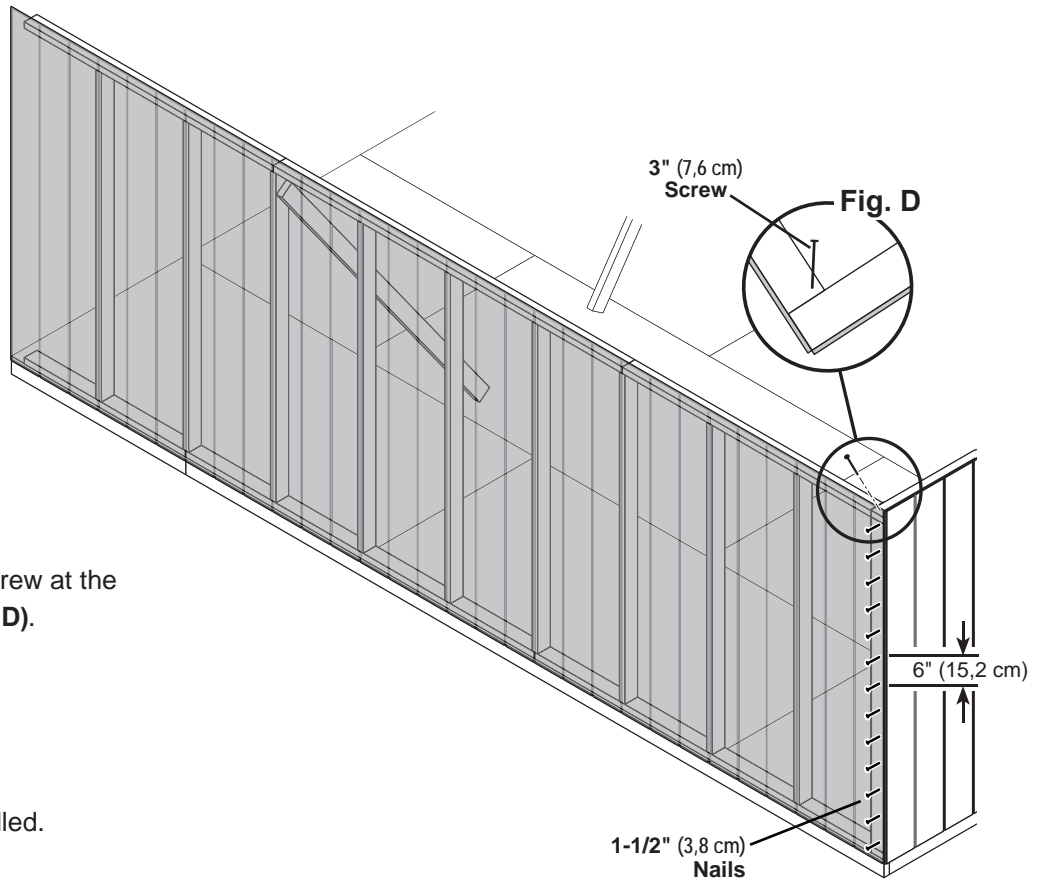

5

Secure wall top plate with (1) 3" screw at the corner at an angle as shown (Fig. D).



Your 2nd 20' wall is now installed.

# 12' GABLE WALL WITH DOOR INSTALLATION

## PARTS REQUIRED

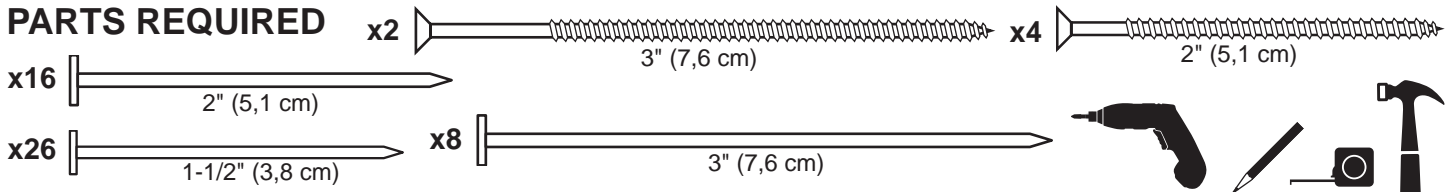

### ✓ BEGIN

- 1 Place 12' gable wall on floor, centered between installed walls.

Secure wall with 2" screws into top and bottom plates (Fig. A, Fig. B).

*Secure wall to bottom plate first.*

⚠ ENSURE PANEL CORNERS ARE FLUSH. ⚠

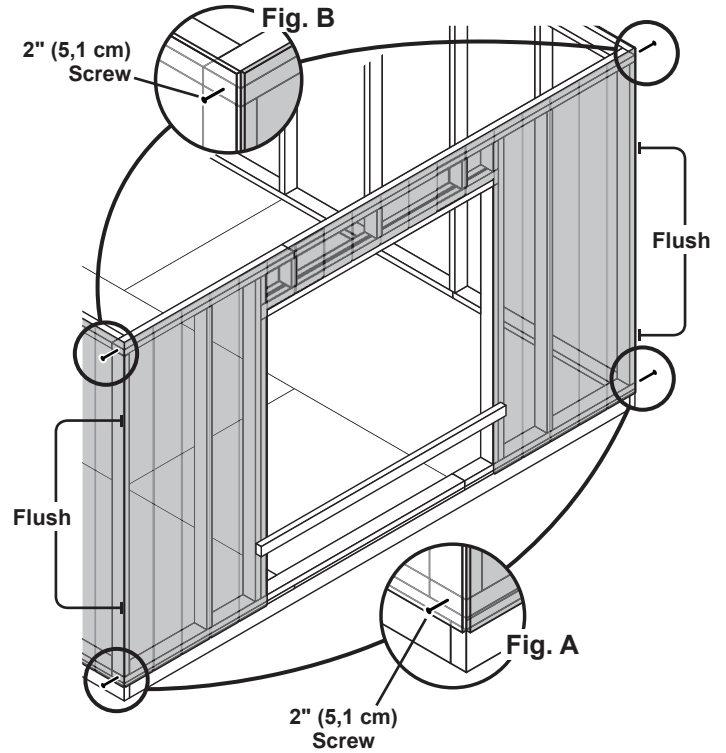

- 2 Nail lower edge of panels to floor with 2" nails spaced 6" apart. Angle nails into floor frame (Fig. C).

Nail panels to 24' wall studs with 1-1/2" nails spaced 6" apart.

- 3 Secure wall top plates with 3" screws at each corner at an angle (Fig. D).

⚠ Nail 2" nails first.  
2" (5,1 cm) Nails

Fig. C

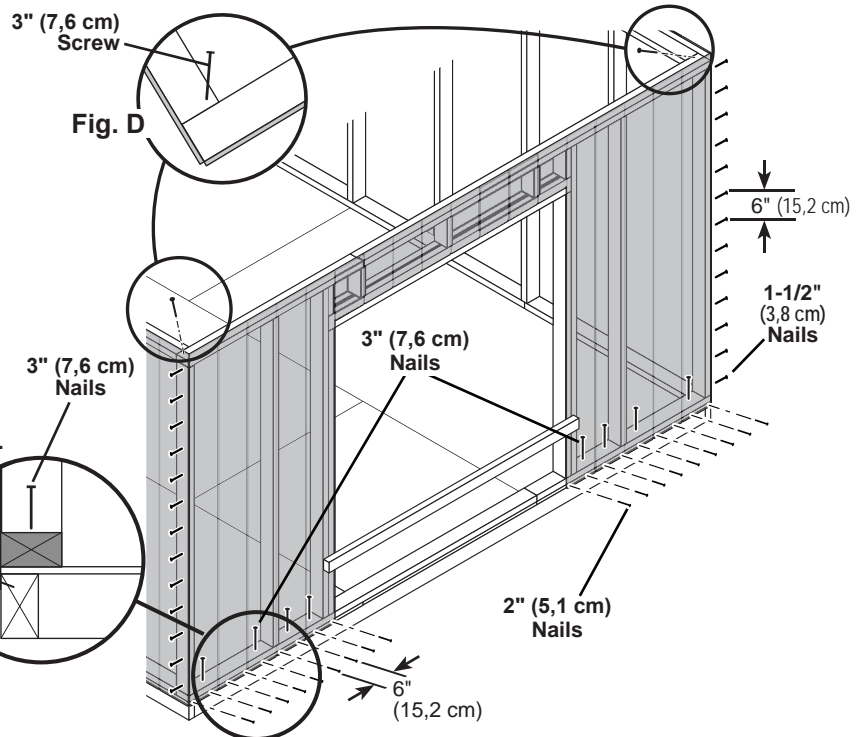

### FINISH



Your walls are now installed.

**CUT OUT AND REMOVE BOTTOM PLATE AT DOOR OPENING.  
REMOVE TEMPORARY BRACING.**

# 12' x 20' WALL DOUBLERS INSTALLATION

## PARTS REQUIRED:

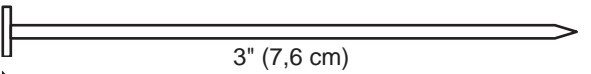
- x2 **SP**  
2 x 4 x 48" (5,1 x 10,2 x 121,9 cm)
- x2 **HVC**  
2 x 4 x 44-3/8" (5,1 x 10,2 x 112,7 cm)
- x2 **TJ**  
2 x 4 x 92-5/8" (5,1 x 10,2 x 235 cm)
- x4 **PT**  
2 x 4 x 96" (5,1 x 10,2 x 243,8 cm)

- x84  3" (7,6 cm)
- x8  3" (7,6 cm)



### BEGIN

**1**

Orient parts on top of wall frames. Measure and mark from end of boards. Secure from top with (2) 3" nails spaced every 24" (Fig. A).

**2**

Secure from bottom with (2) 3" screws at each corner (Fig. B).

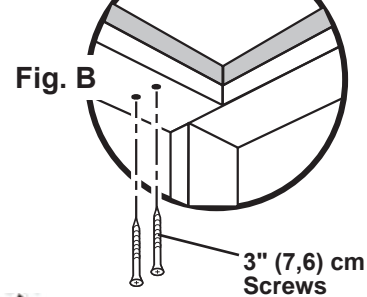
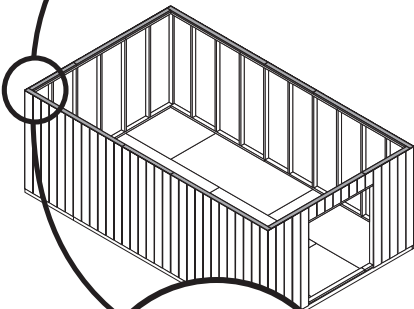
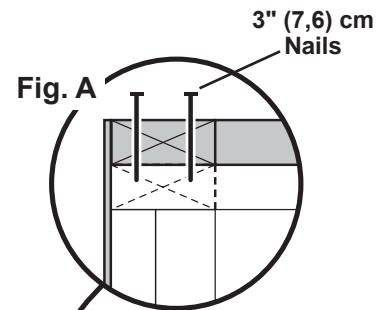

Your wall doublers are now installed.

CONTINUE TO PAGE 51 TO RESUME CONSTRUCTION OF 12' X 20' SHED.

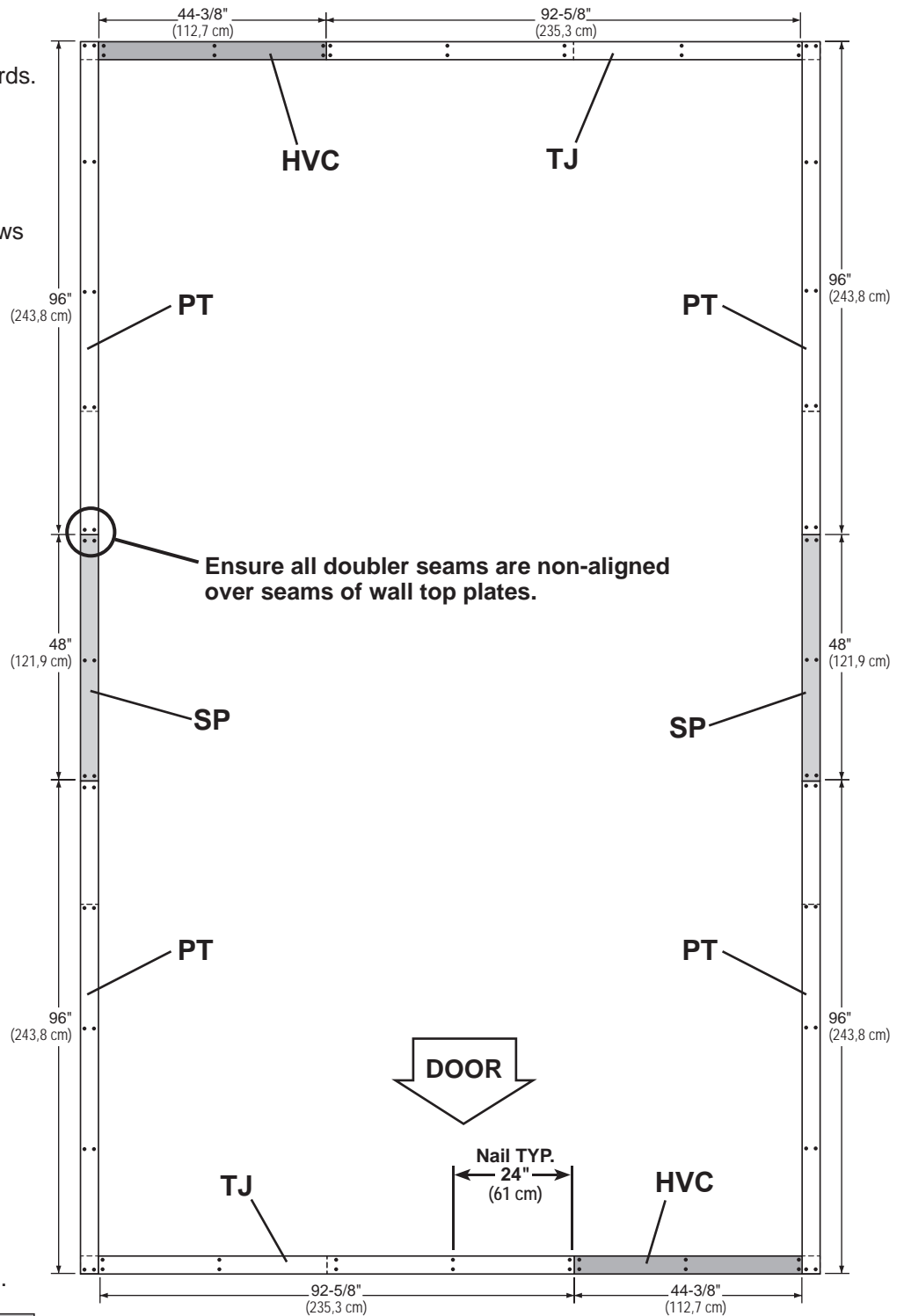

# 12' GABLE WALL 02 INSTALLATION

## PARTS REQUIRED:

x1 **OO**  
69" (175,3 cm) Door Stiffener



x12 3" (7,6 cm)  
x2 3" (7,6 cm)  
x27 2" (5,1 cm)

### ✓ BEGIN

- Center 12' wall on the 120" (304,8 cm) floor dimension. 1-1/2" (3,8 cm) overlap is to the top.

Use **OO** as a temporary brace.  
Secure with (2) 3" screws.

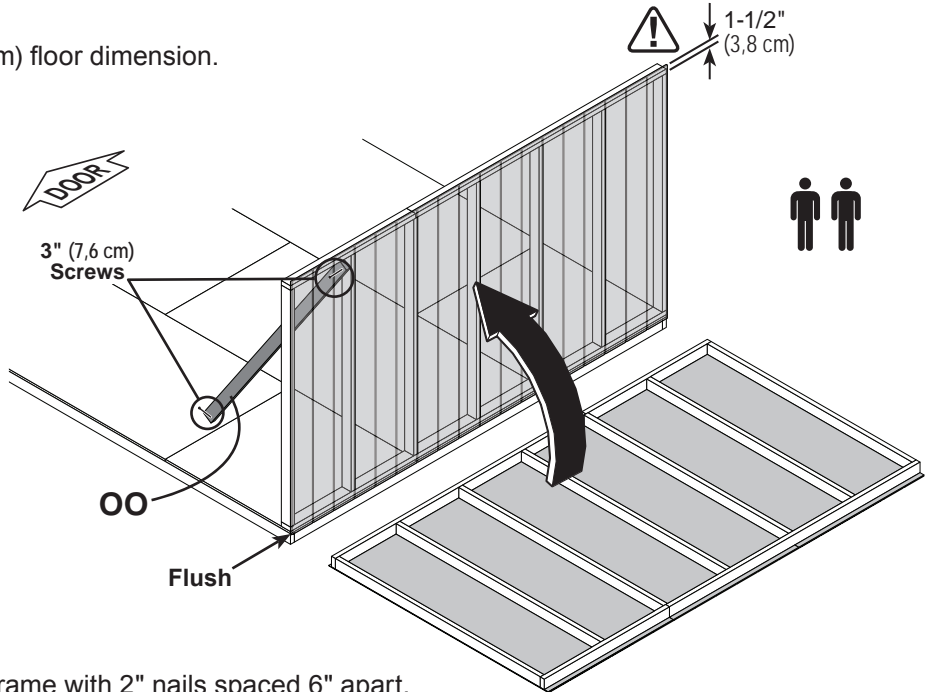

- Secure lower edge of panel to floor frame with 2" nails spaced 6" apart. Angle nails into floor frame (**Fig. A**).

Secure wall bottom plates to floor with 3" nails (**Fig. A**).

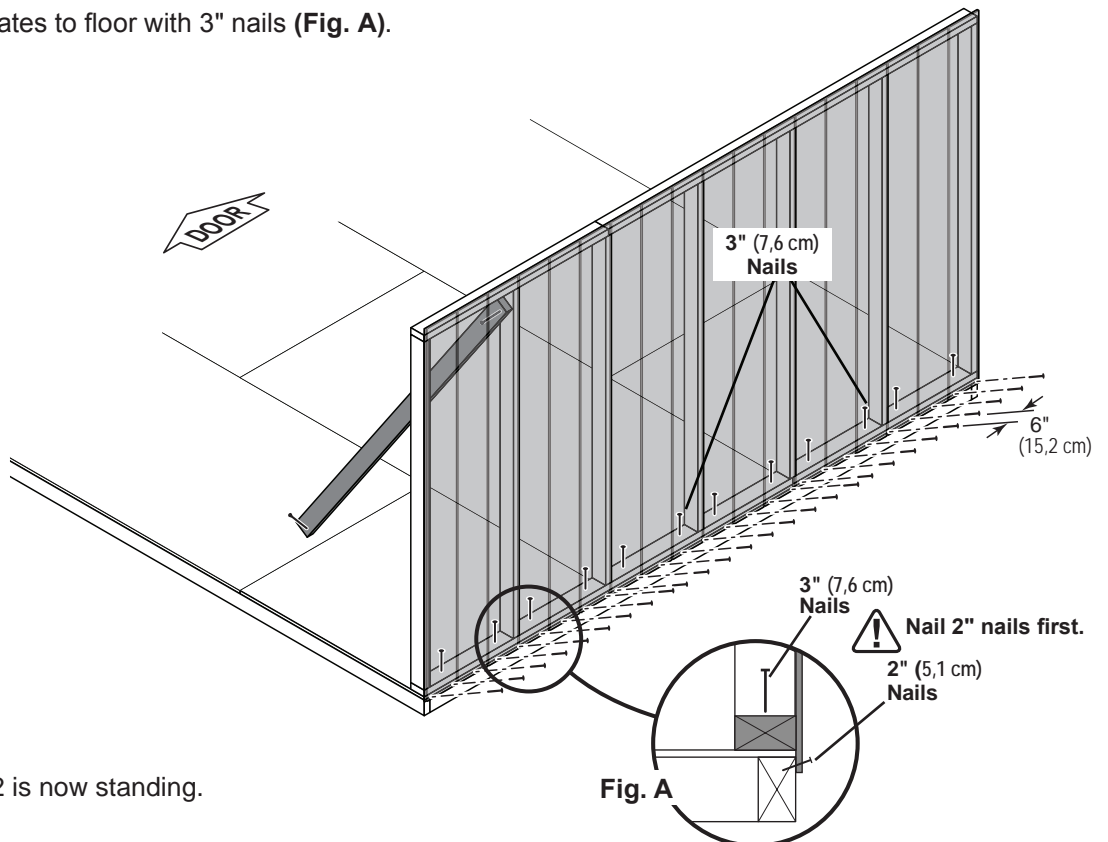

Your 12' gable wall 02 is now standing.

# 1st 24' EAVE WALL INSTALLATION

## PARTS REQUIRED

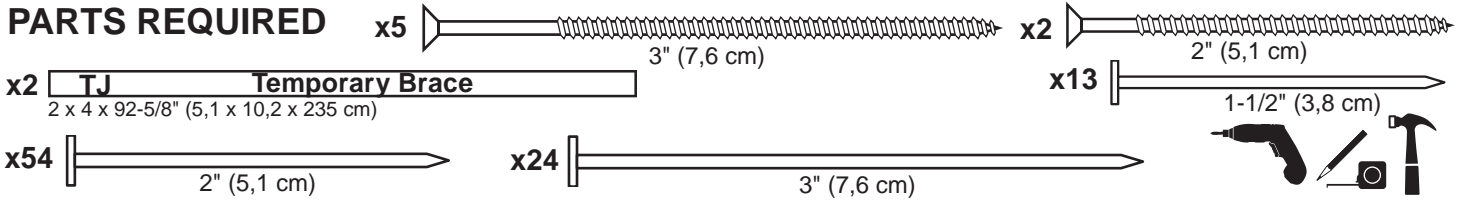

### ✓ BEGIN 1



Place 1st 24' eave wall centered on floor. The 1-1/2" (3,8 cm) overlap is to the top. Use (2) TJ as a temporary brace, as shown. Secure TJ with (2) 3" screws.

Secure wall with (1) 2" screw into 12' wall bottom plate (Fig. A) and top plate (Fig. B).

**Secure wall to bottom plate first.**

**⚠ ENSURE PANEL CORNERS ARE FLUSH.**

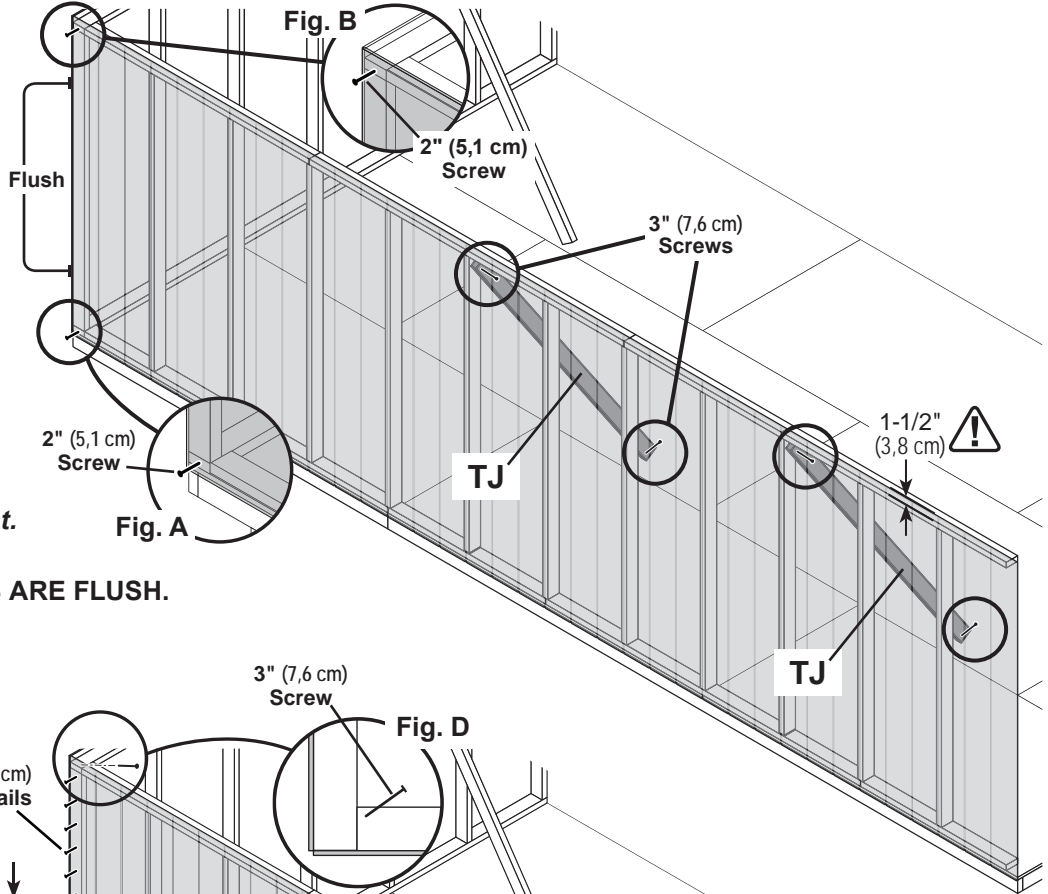

### 2

Nail lower edge of panels to floor with 2" nails spaced 6" apart. Angle nails into floor frame (Fig. C).

Secure panel to 12' wall stud with 1-1/2" nails spaced 6" apart.

### 3

Secure wall top plate with (1) 3" screw at the corner at an angle, as shown (Fig. D).

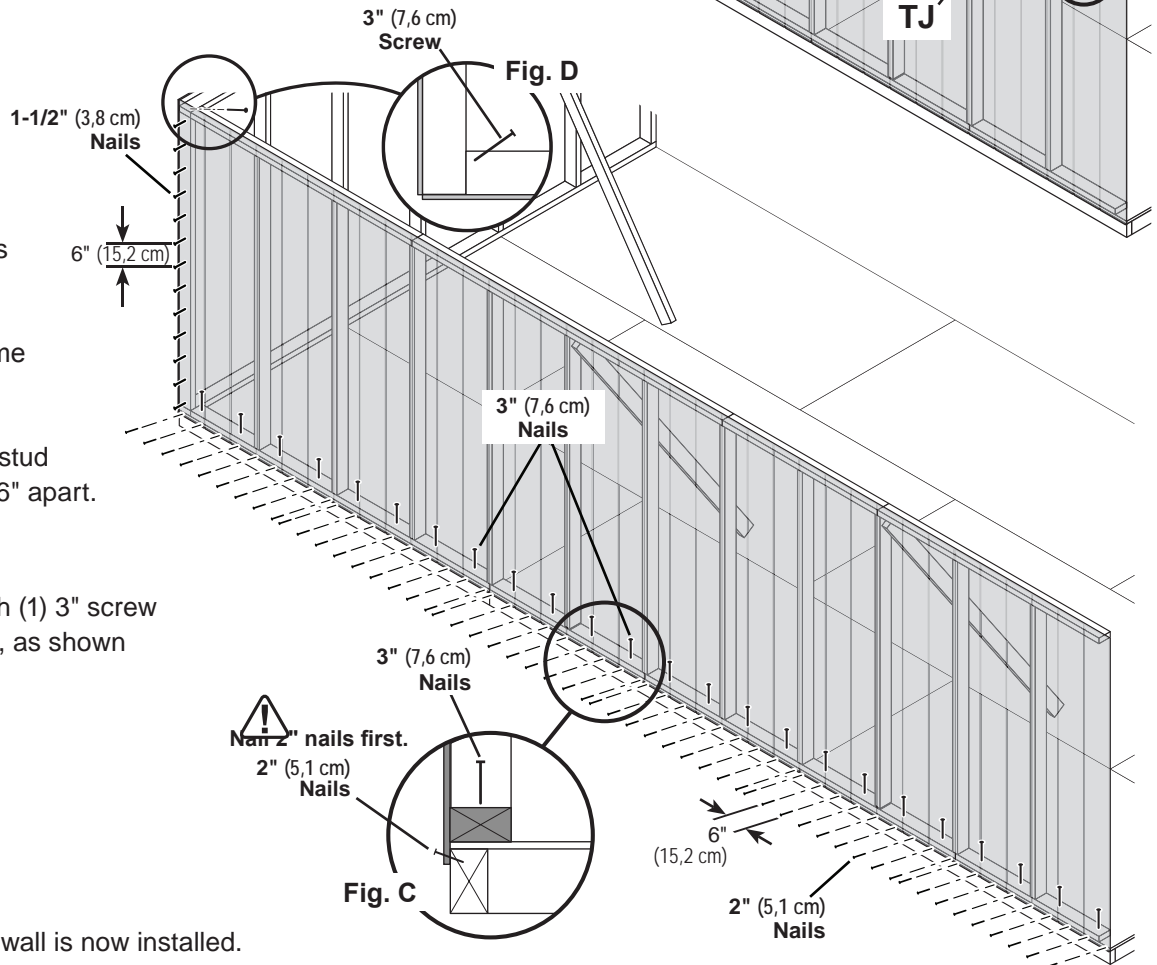

Your 1st 24' eave wall is now installed.

## 2nd 24' EAVE WALL INSTALLATION

### PARTS REQUIRED:

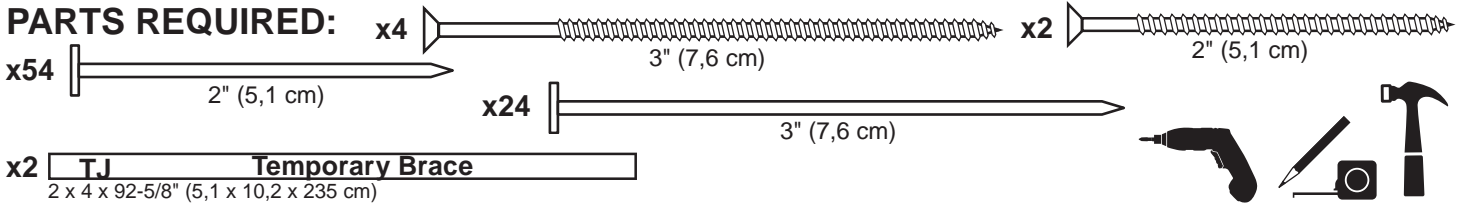

**✓ BEGIN**  
**1**



Place 2nd 24' wall centered on floor.  
The 1-1/2" (3,8 cm) overlap is to the top.

Use **TJ** as a temporary brace as shown.  
Secure **TJ** with (2) 3" screws.

**2**

Secure wall with (1) 2" screw through gable wall panel into 12' wall bottom and top plates (**Fig. A**, **Fig. B**).

*Secure wall to bottom plate first.*

**⚠ ENSURE PANEL CORNERS ARE FLUSH.**

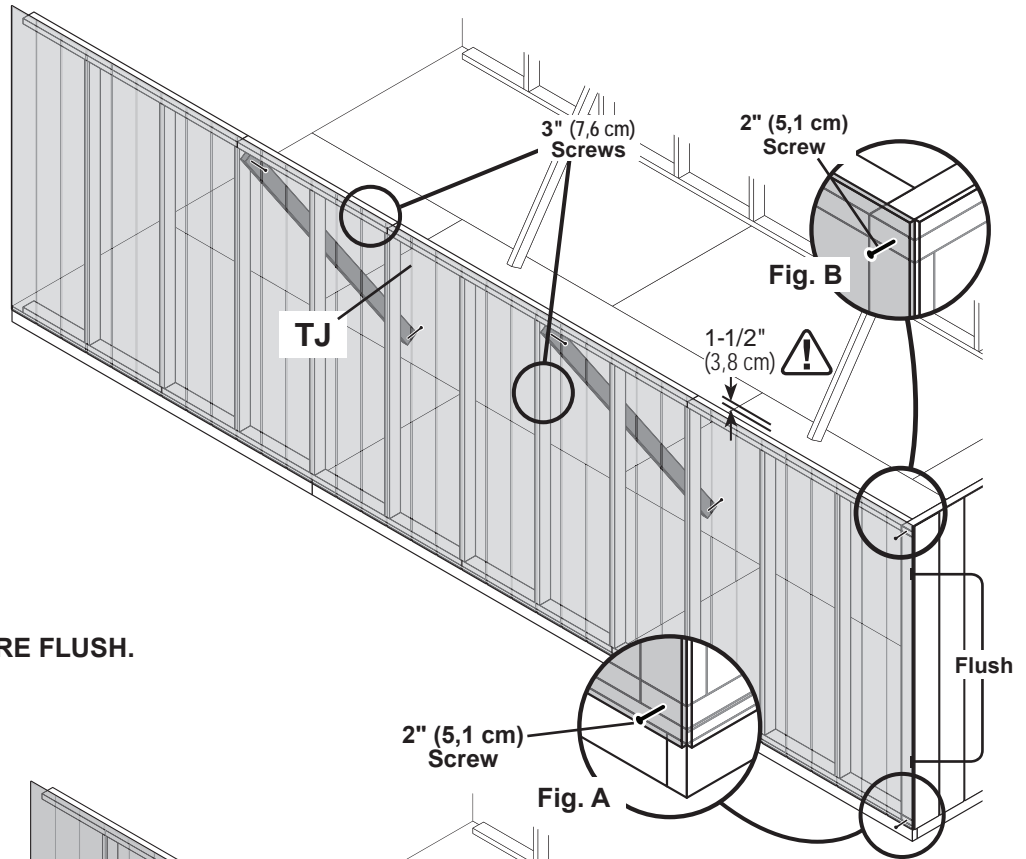

**3**

Nail lower edge of wall panels to floor frame with 2" nails spaced 6" apart. Angle nails into floor frame (**Fig. C**).

Secure wall bottom plates to floor with 3" nails (**Fig. C**).

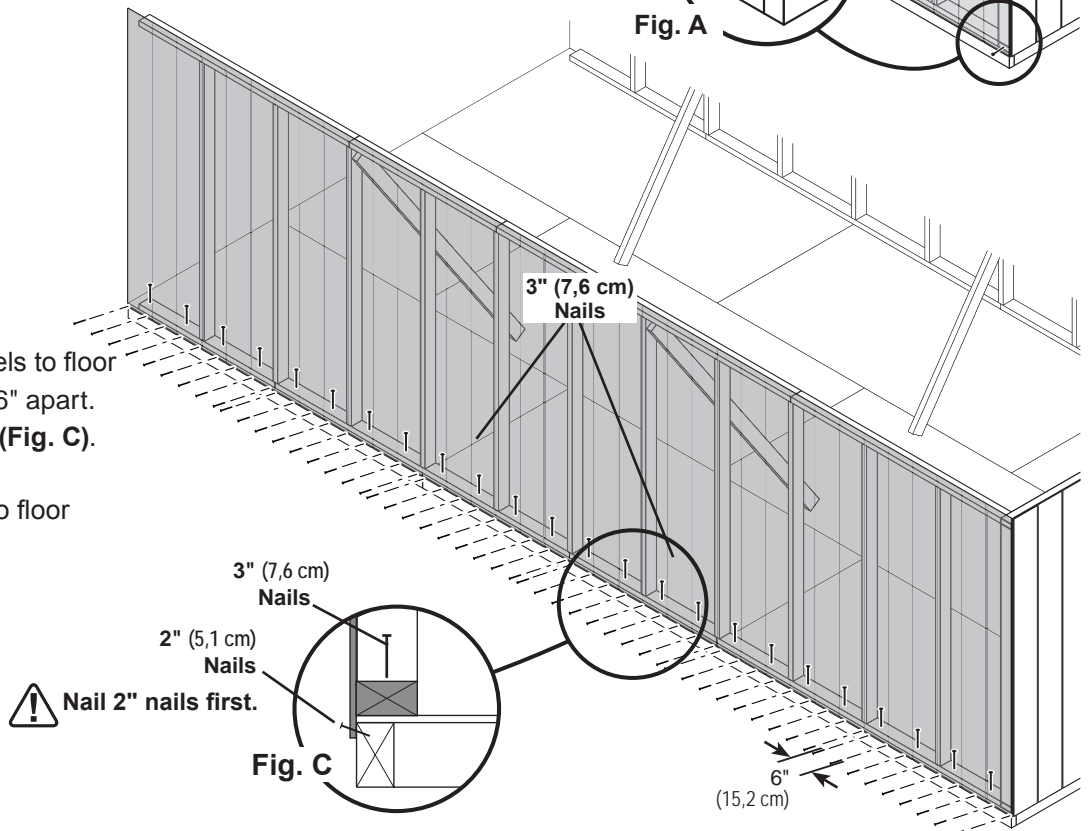

## 2nd 24' EAVE WALL INSTALLATION

### PARTS REQUIRED:

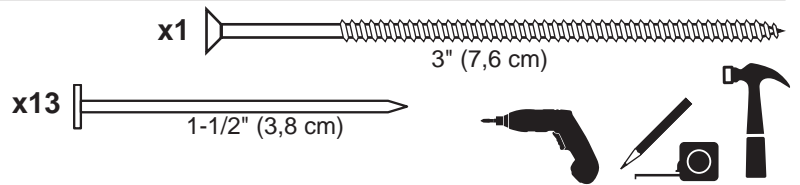

4

Secure 24' wall panel to 12' wall stud with 1-1/2" nails spaced 6" apart.

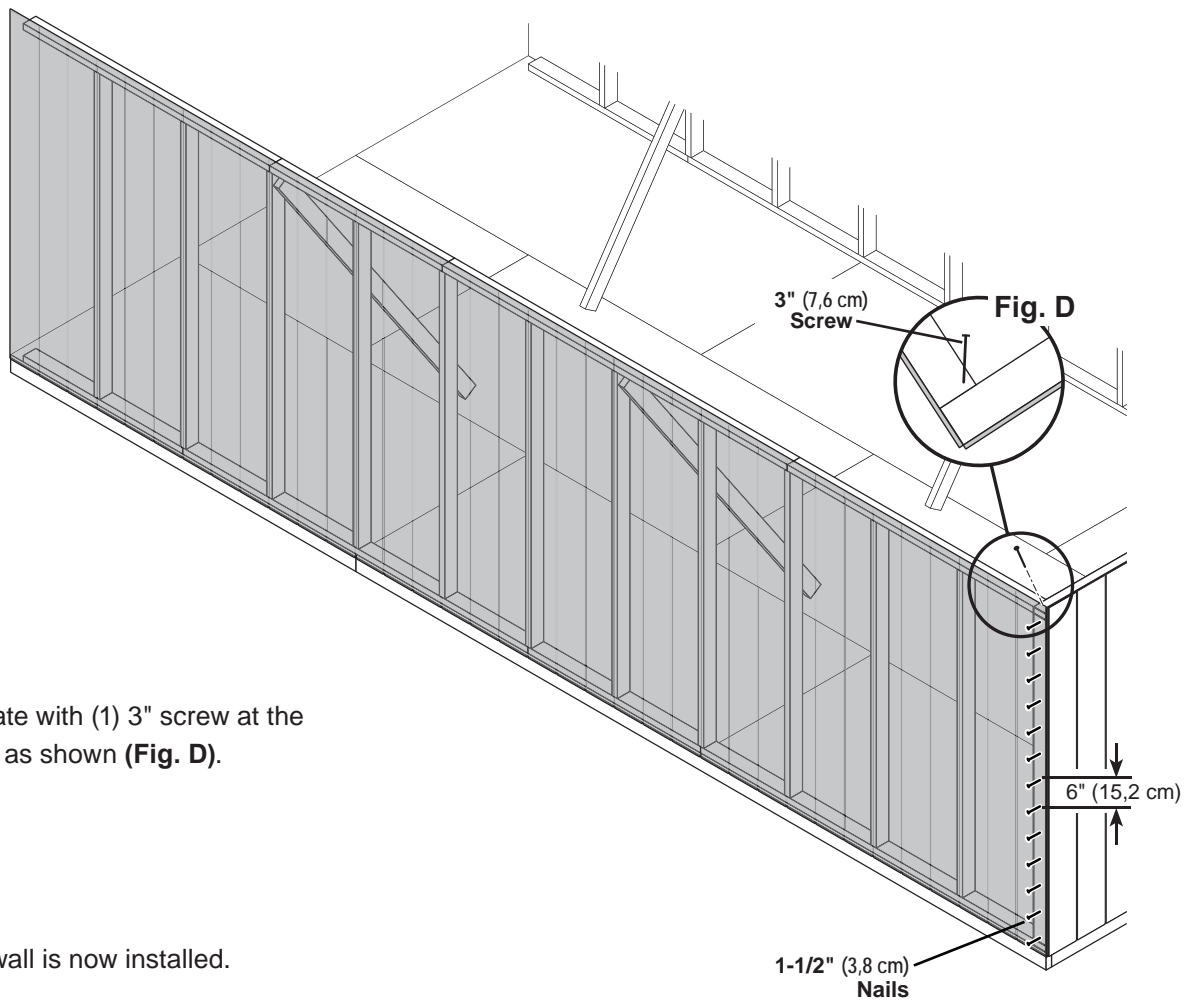

5

Secure wall top plate with (1) 3" screw at the corner at an angle as shown (Fig. D).



Your 2nd 24' wall is now installed.

# 12' GABLE WALL WITH DOOR INSTALLATION

## PARTS REQUIRED

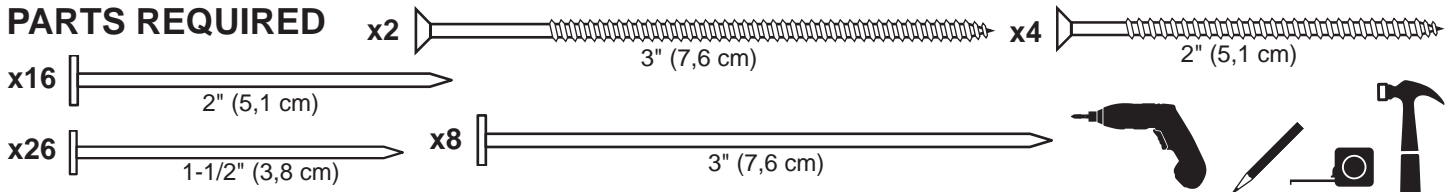

### ✓ BEGIN



**1** Place 12' gable wall on floor, centered between installed walls.

Secure wall with 2" screws into top and bottom plates (Fig. A, Fig. B).

*Secure wall to bottom plate first.*

**⚠ ENSURE PANEL CORNERS ARE FLUSH. ⚠**

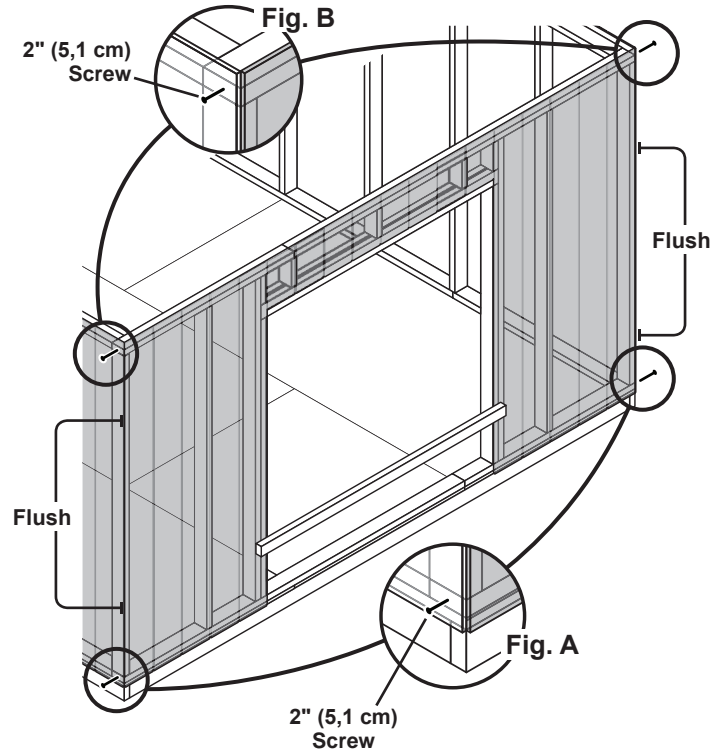

**2** Nail lower edge of panels to floor with 2" nails spaced 6" apart. Angle nails into floor frame (Fig. C).

Nail panels to 24' wall studs with 1-1/2" nails spaced 6" apart.

**3** Secure wall top plates with 3" screws at each corner at an angle (Fig. D).

**⚠ Nail 2" nails first.**  
2" (5,1 cm) Nails

Fig. C

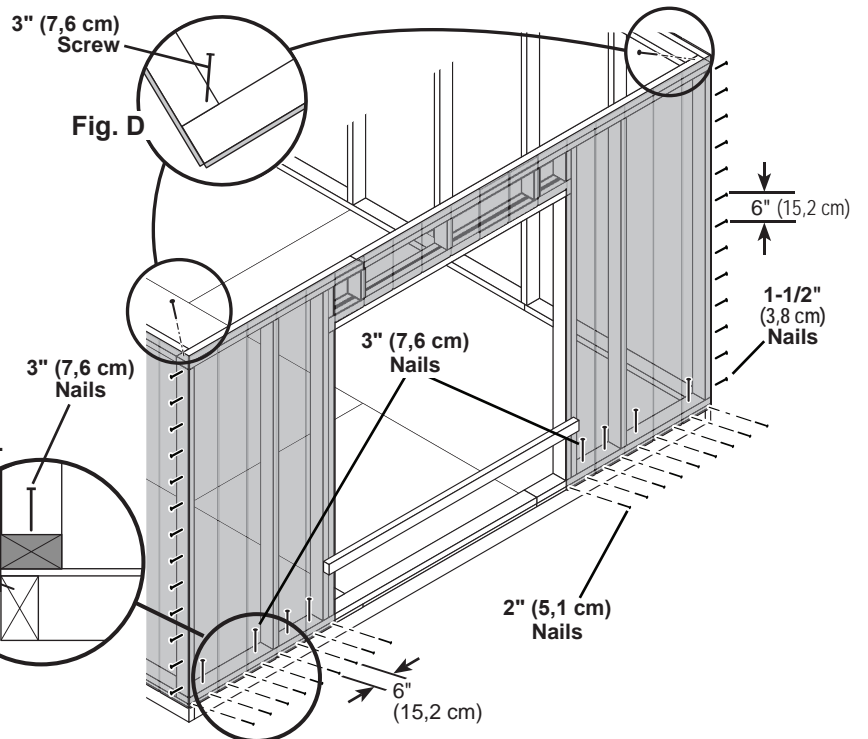

### FINISH

Your walls are now installed.

**CUT OUT AND REMOVE BOTTOM PLATE AT DOOR OPENING.  
REMOVE TEMPORARY BRACING.**

# 12' x 24' WALL DOUBLERS INSTALLATION

- PARTS REQUIRED:** x2 **HVC** 2 x 4 x 44-3/8" (5,1 x 10,2 x 112,7 cm) x84 3" (7,6 cm)  
 x4 **SP** 2 x 4 x 48" (5,1 x 10,2 x 121,9 cm) x8 3" (7,6 cm)  
 x2 **TJ** 2 x 4 x 92-5/8" (5,1 x 10,2 x 235 cm) x4 **PT** 2 x 4 x 96" (5,1 x 10,2 x 243,8 cm)

**BEGIN**

**1**  
 Orient parts on top of wall frames.  
 Measure and mark from end of boards.  
 Secure from top with (2) 3" nails spaced every 24" (Fig. A).

**3**  
 Secure from bottom with (2) 3" screws at each corner (Fig. B).

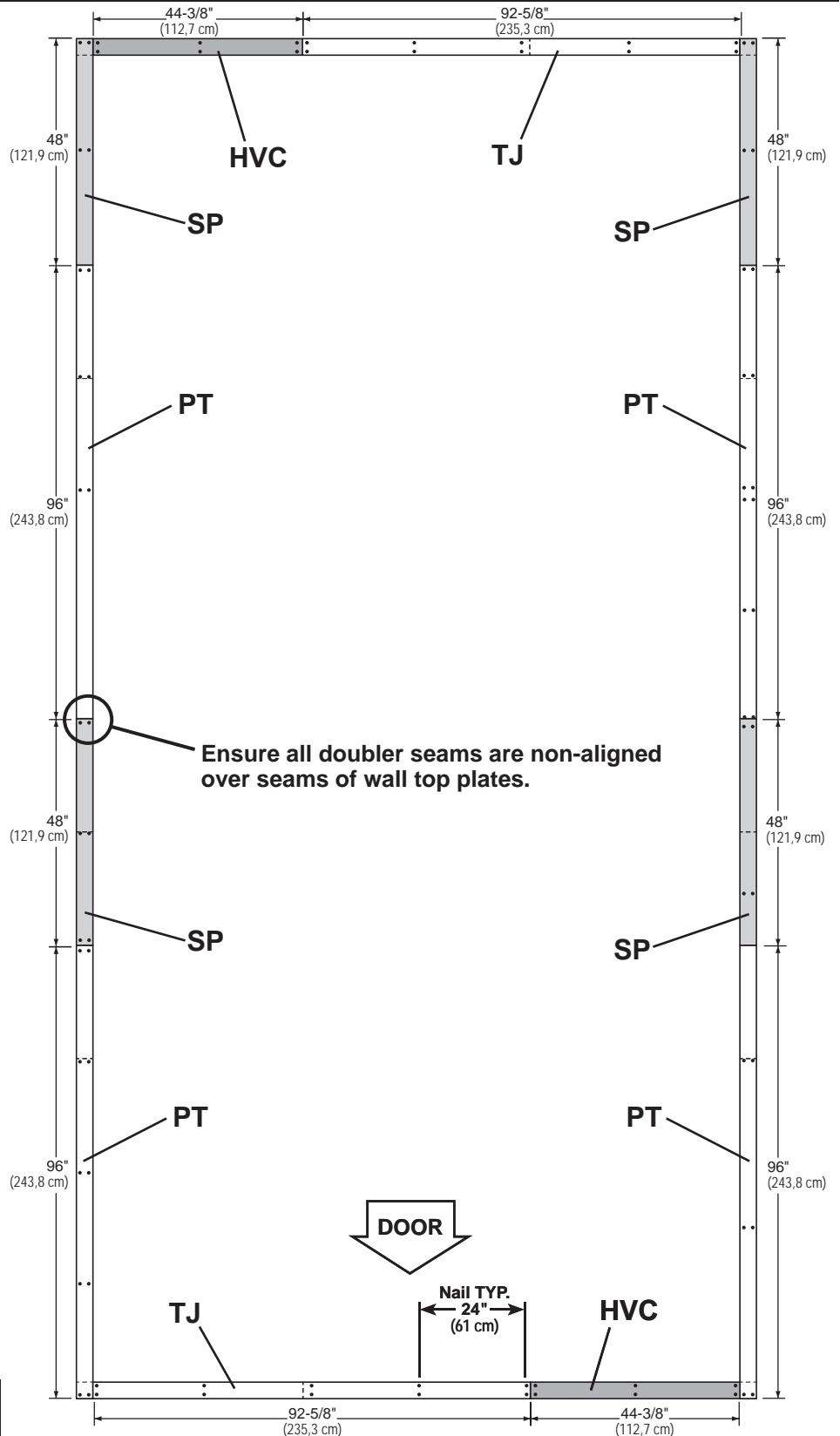
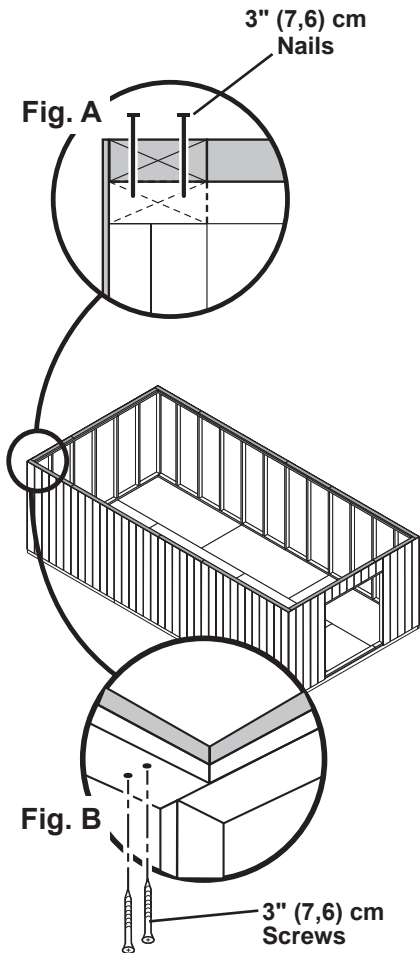

Your wall doublers are now installed.

**CONTINUE TO NEXT PAGE TO RESUME CONSTRUCTION OF 12' X 24' SHED.**

*Please continue to the included booklet*



# ***PART 2***

*to complete your shed.*

**RAFTERS**

12x12' 12x16' 12x20' 12x24'

**PARTS REQUIRED:**

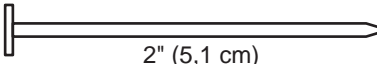
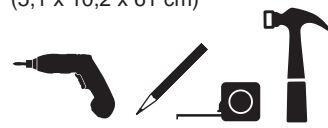
x12	x16	x20	x24	 6 x 24" (15,2 x 60,9 cm)	x2	 3" (7,6 cm)
x14	x18	x22	x26	<b>ADA</b>	x1	<b>RL</b> Temporary Support 2 x 4 x 24" (5,1 x 10,2 x 61 cm)
x144	x192	x240	x288	 2" (5,1 cm)		

**Build (2) rafter assemblies with (1) gusset (Fig. B).**

**BEGIN**

- Place two rafter-halves **AD** in the corner of back and side walls, flush to panels and studs.  
Flush rafters at peak. Secure gusset to rafters with 2" nails following the pattern shown (**Fig. A**).

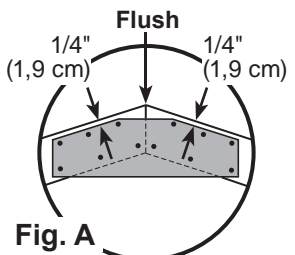

**HINT:**  
Use floor and walls to help assemble rafters!

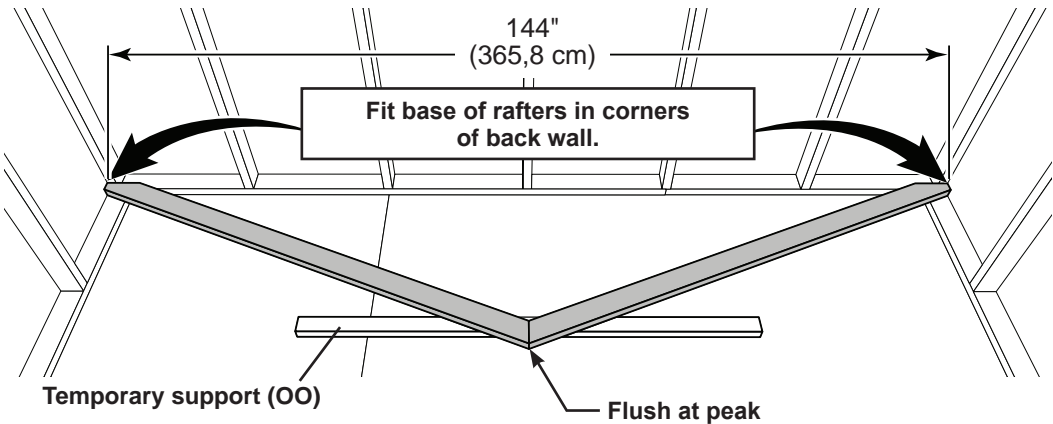

**SET ASIDE THESE TWO RAFTER ASSEMBLIES.**

**Depending on your shed size, build rafters with (2) gussets (Fig. C).**

- Place two rafter-halves on floor and flush in the corners of wall and **RL**, as shown in STEP - 1. Flush rafters at peak. Secure gusset to rafters with 2" nails following the pattern shown (**Fig. A**).
- Flip over rafter assembly and fasten second gusset to other side with 2" nails (**Fig. C**).

**Fig. B - Build 2 for all sizes**

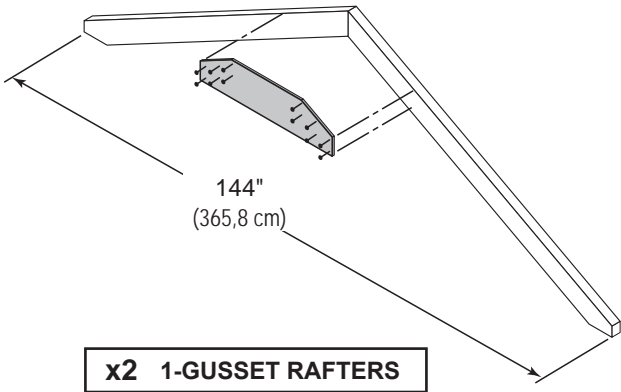

**Fig. C**

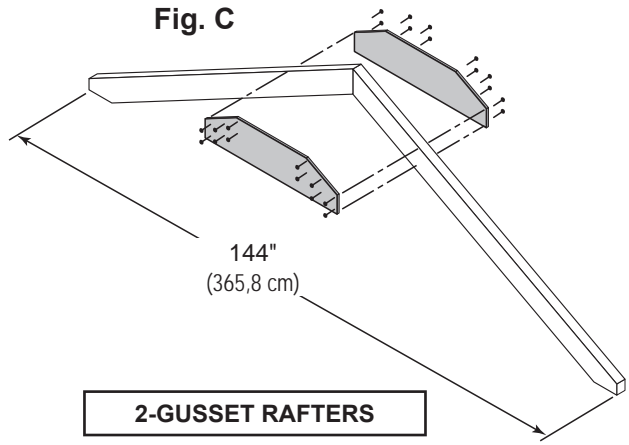

12x12' 12x16' 12x20' 12x24'

x5
x7
x9
x11



Your rafters are now assembled.  
Remove RL and screws from floor.

# 12x12' 12x16' RAFTER INSTALLATION

**PARTS REQUIRED:**



- 12x12' **x5**
- 12x16' **x7**
- x28**
- x36**

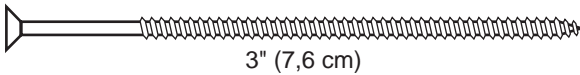

**BEGIN**

**1** Align rafters over the wall studs.



Check that you have the measurements shown.

Secure rafters with (2) 3" screws angled at each end (**Fig. A, Fig. B**).

Secure rafters on opposite side.

**!** *Maintain the measurements between rafters.*

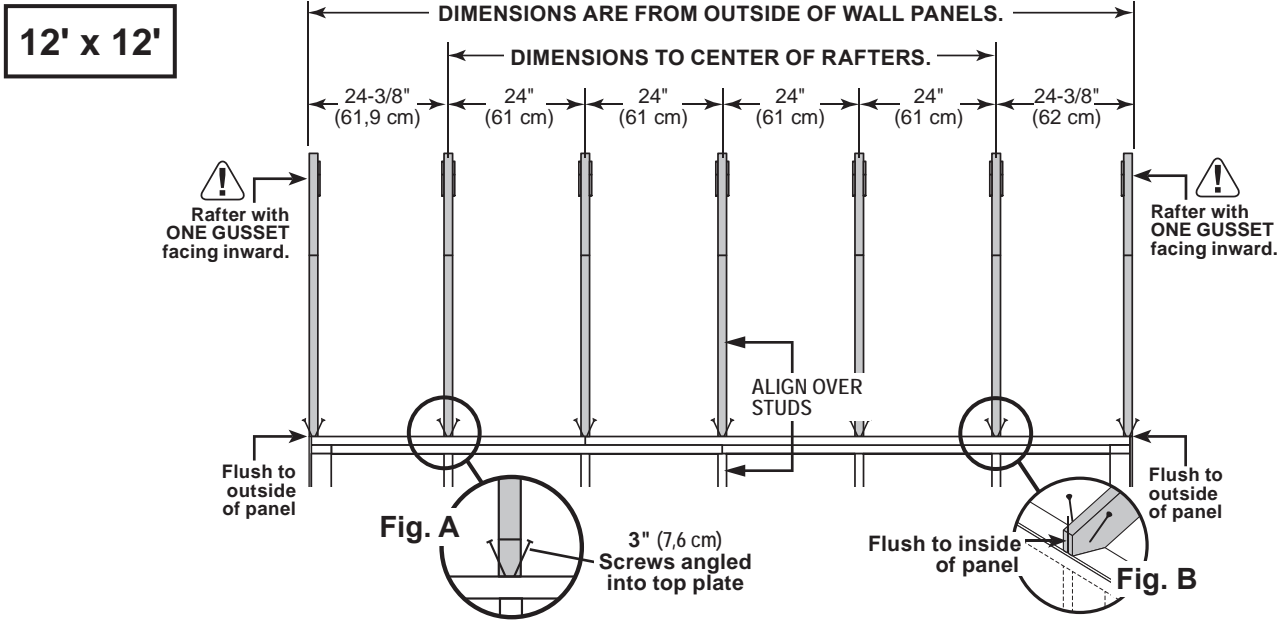

**!** *Maintain the measurements between rafters.*

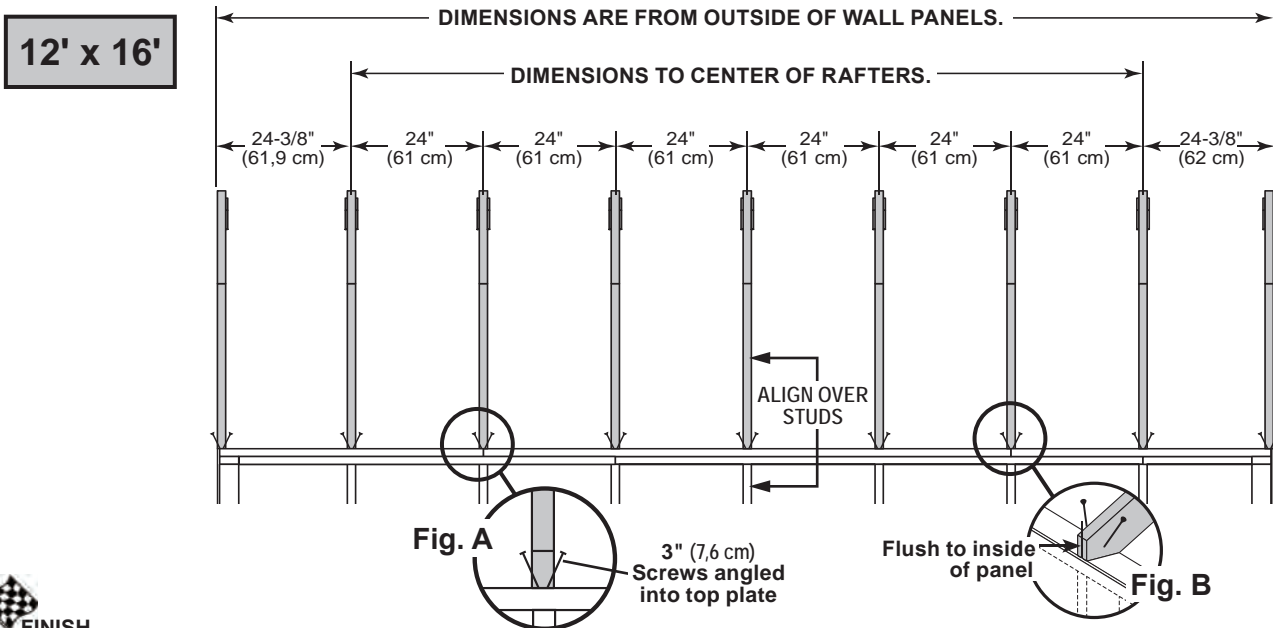

**FINISH**

Your rafters are now installed.

# 12x20' 12x24' RAFTER INSTALLATION

## PARTS REQUIRED:

	<b>x9</b>	<b>x11</b>	 2-Gusset Preassembled	 x2 1-Gusset Preassembled
	<b>x44</b>	<b>x52</b>	 3" (7,6 cm)	

### ✓ BEGIN

**1** Align rafters over the wall studs.



- Check that you have the measurements shown.
- Secure rafters with (2) 3" screws angled at each end (**Fig. A, Fig. B**).
- Secure rafters on opposite side.

**!** *Maintain the measurements between rafters.*

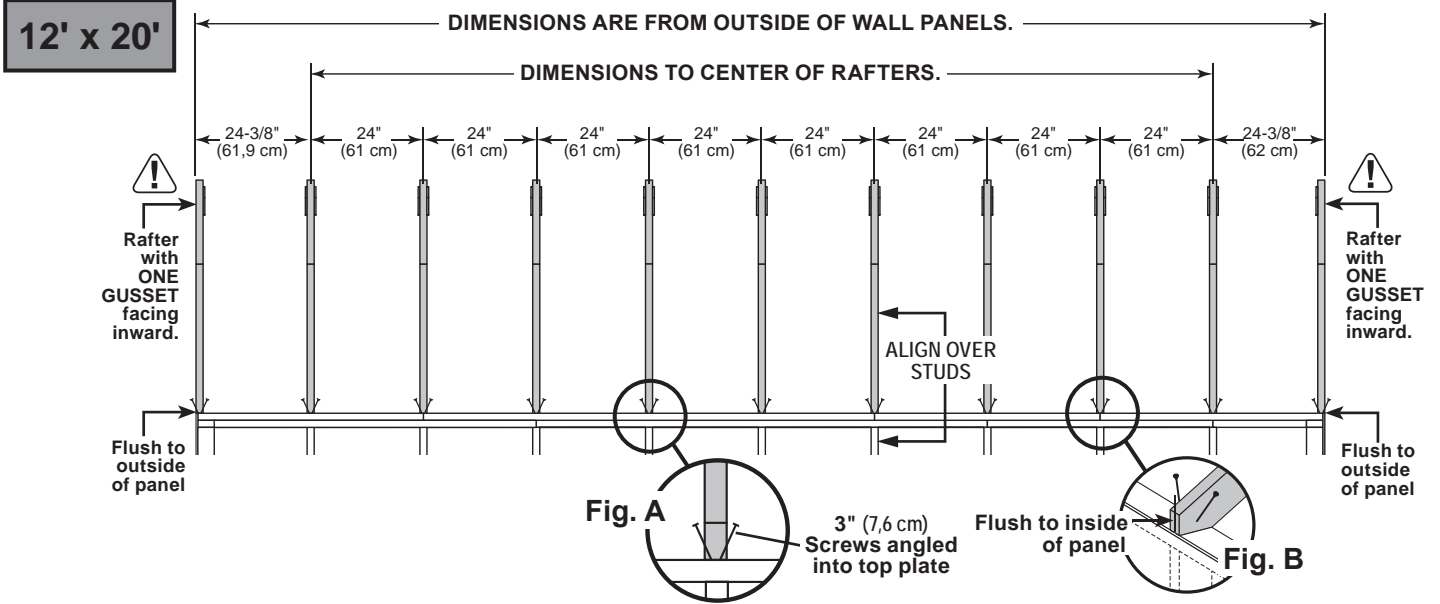

**!** *Maintain the measurements between rafters.*

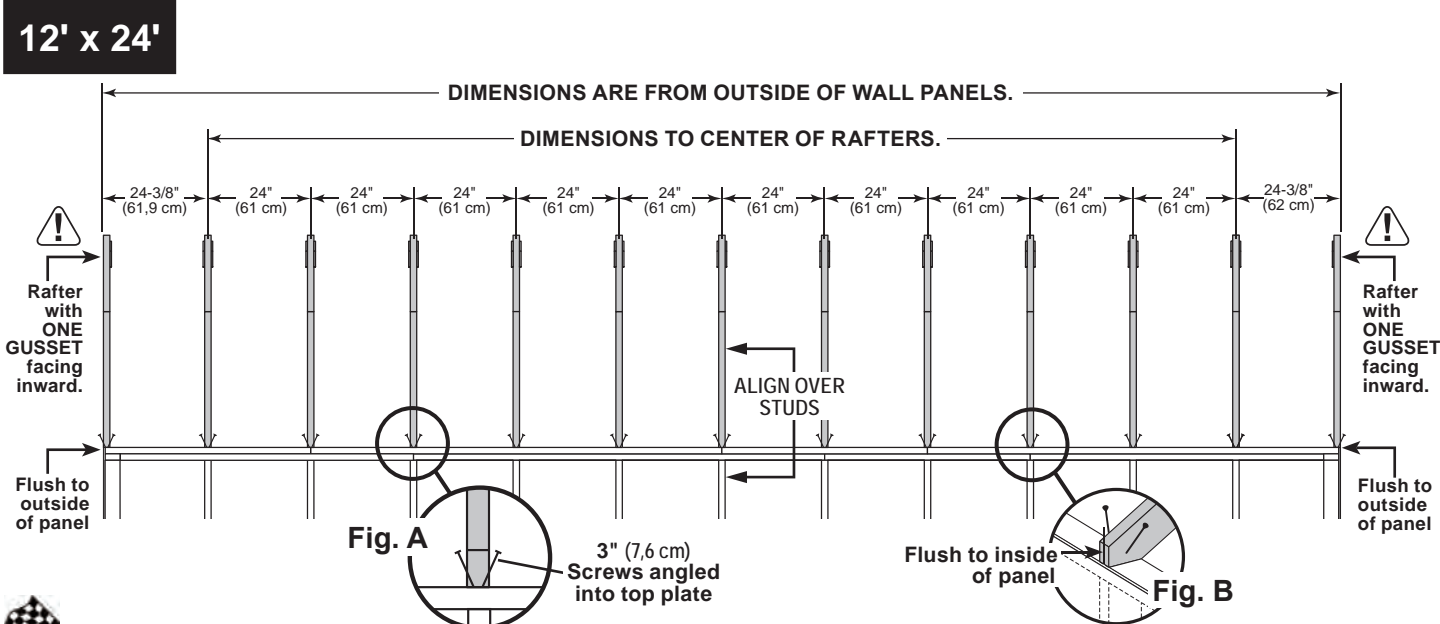

### FINISH

Your rafters are now installed.

## GABLE UNITS

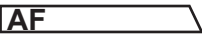
**PARTS REQUIRED:** x4 **AF**  2 x 4 x 18-1/8" (5,1 x 10,2 x 46 cm)

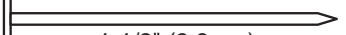
x32  1-1/2" (3,8 cm)

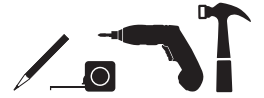
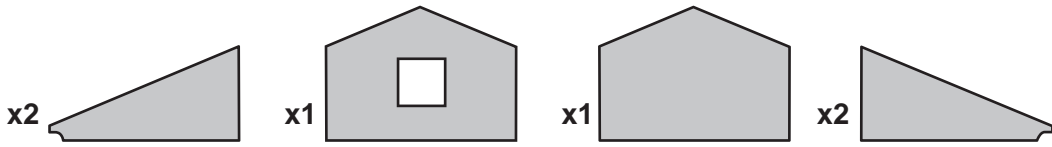

*Install gable panels with the primed side facing up.*

**✓ BEGIN**

**1** Place middle panel on (2) **AF**. Arrange parts to measurements shown.

Secure panel with 1-1/2" nails spaced 6" apart along edge.

Check measurements as you build the gable unit.

**2** Place left and right panels on **AF**, flush to middle panel.

Secure panel with 1-1/2" nails spaced 6" apart along edge.

Mark the center of the middle gable panel.

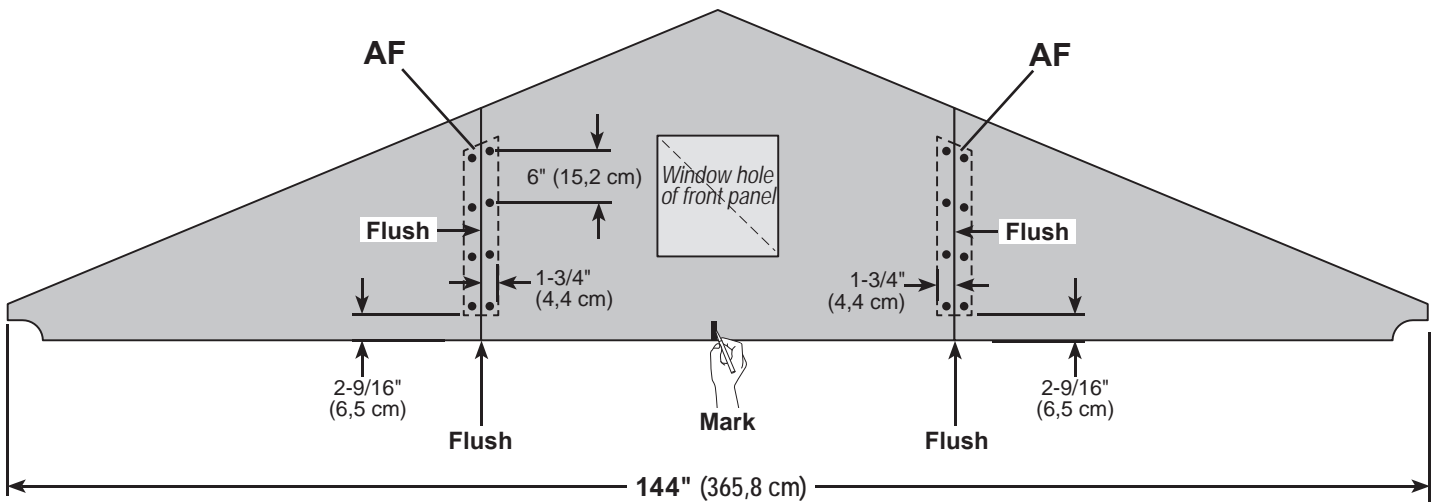

Repeat steps to assemble the 2nd gable unit.



Your (2) gable units are now assembled.

# GABLE INSTALLATION

## PARTS REQUIRED:

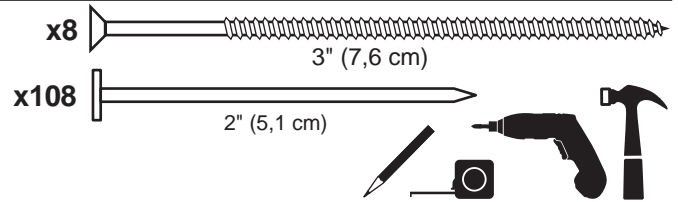
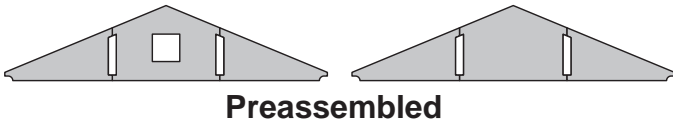

### ✓ BEGIN

- 1 Measure 2-9/16" (6,5 cm) down from top plate doubler and mark at each side as shown. Set gable unit on top plate. Fasten with (1) 2" nail on each side.



**⚠ BE SURE GABLE IS CENTERED ON WALL BEFORE NAILING.**

Continue nailing lower edge of panels to wall doubler with 2" nails spaced 6" apart.

- 2 Secure gable panels to rafter with with 2" nails spaced 6" apart.

- 3 Working inside, secure gable unit with (2) 3" screws angled into each **AF** at an angle (**Fig. A**).

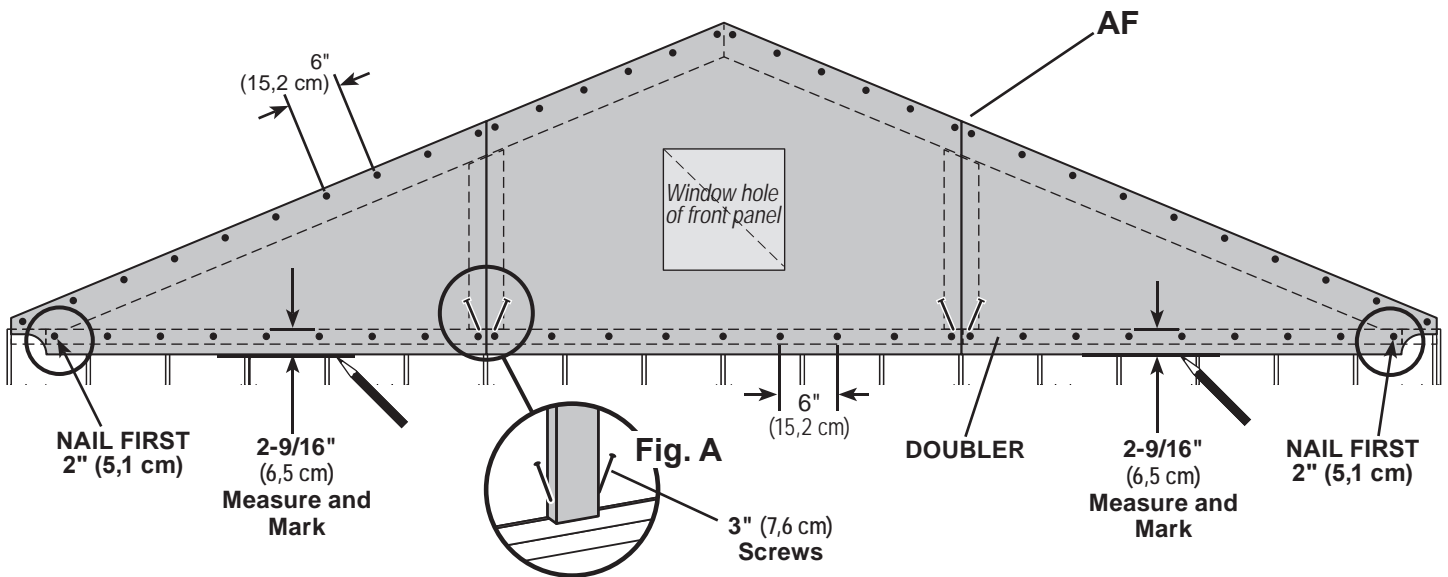

Repeat steps to install the opposite side gable.



Your gable units are now installed.

# 12' x 12' ROOF PANELS

## PARTS REQUIRED:

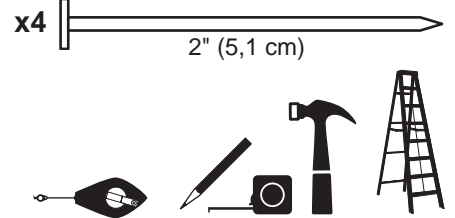

 Roof panels may cause serious injury until securely fastened.  
*Note: Install all roof panels with the rough side up (painted grid lines).*



✓ BEGIN

1

Place the 48" x 96" panel on rafters with a 3/4" measurement on the rafter (**Fig. A**) and the panel flush at the peak (**Fig. B**).

Secure panel with (2) 2" nails in the corners.

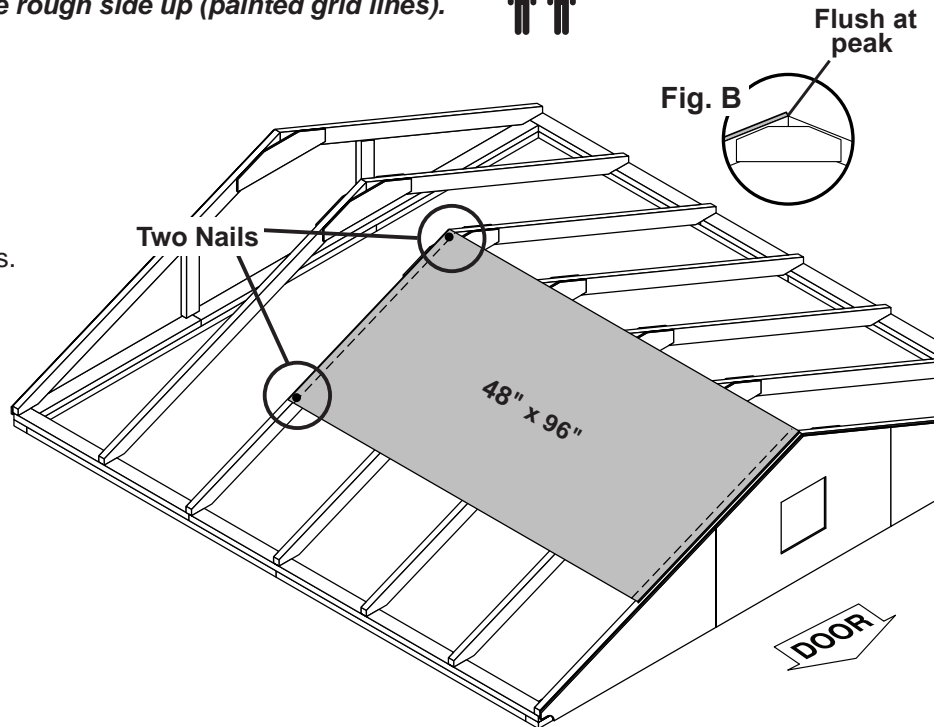
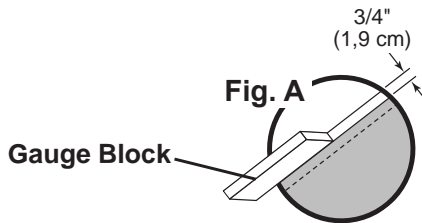

2

Move to the opposite end.  
Using the long edge of the panel as a lever, move the panel side-to-side until the top corner is flush to the peak (**Fig. B**) and there is a 1/2" measurement on the gable end rafter (**Fig. C**).

Secure panel with (2) 2" nails in the corners.

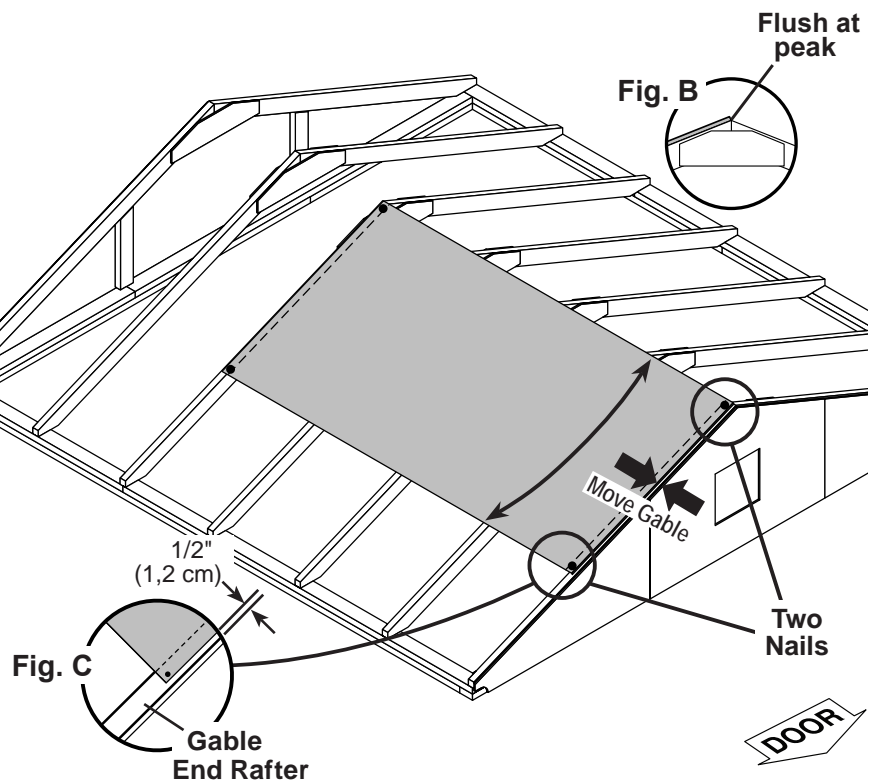

# 12' x 12' ROOF PANELS

## PARTS REQUIRED:

x1  47-7/8" x 48"  
(121,6 x 121,9 cm)

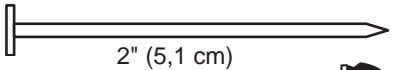

x12  2" (5,1 cm)

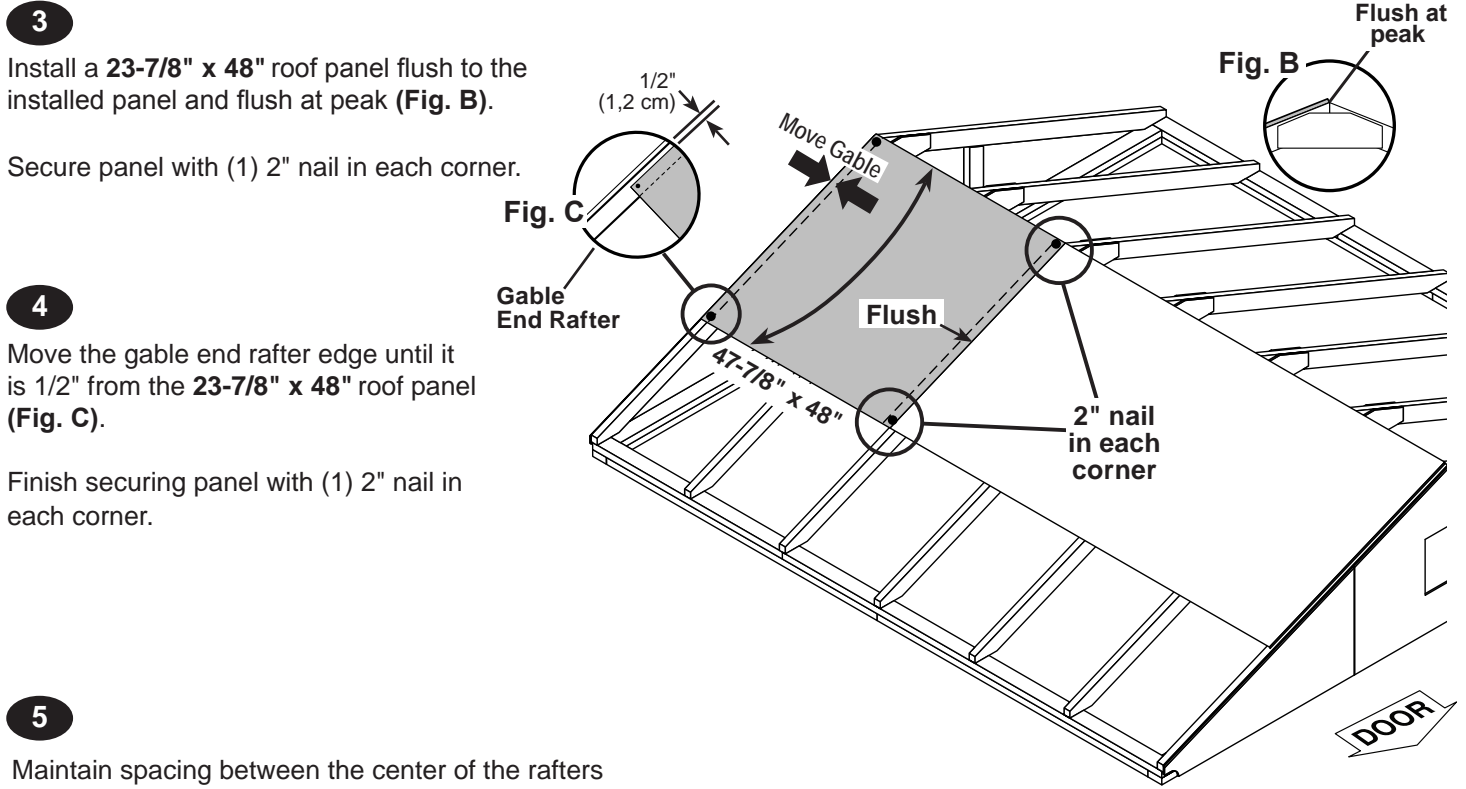

**3**  
Install a 23-7/8" x 48" roof panel flush to the installed panel and flush at peak (**Fig. B**).

Secure panel with (1) 2" nail in each corner.

**4**  
Move the gable end rafter edge until it is 1/2" from the 23-7/8" x 48" roof panel (**Fig. C**).

Finish securing panel with (1) 2" nail in each corner.

**5**  
Maintain spacing between the center of the rafters at the lower edge of the panels (**Fig. D**).

Secure panels with (1) 2" nail into each rafter, as shown.

Move to the top of the panel and keep spacing between the center of the rafters.

Secure panels with (1) 2" nail into each rafter.

**Fig. D**

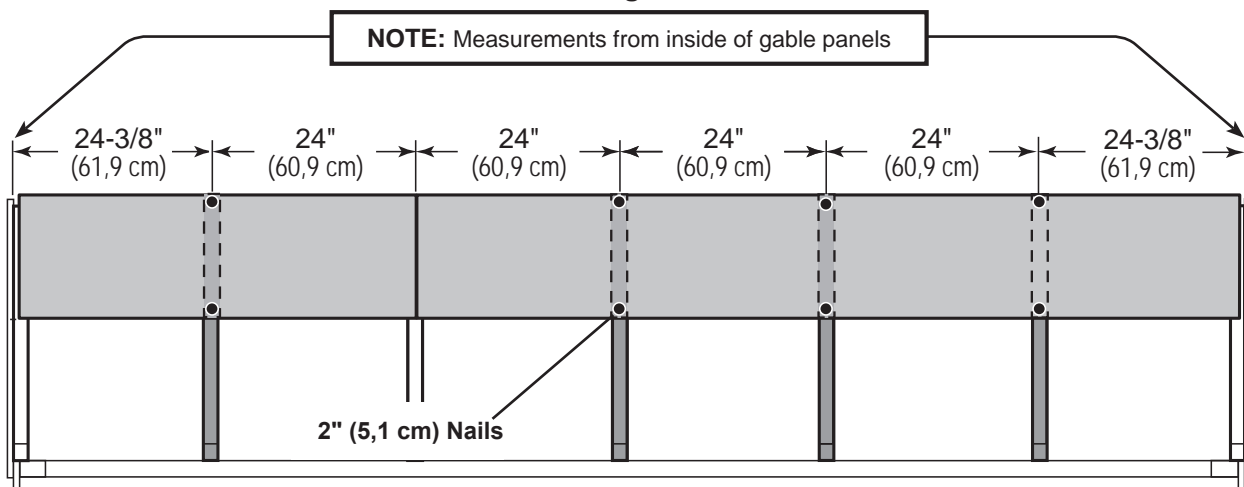

# 12' x 12' ROOF PANELS

## PARTS REQUIRED:

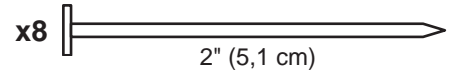
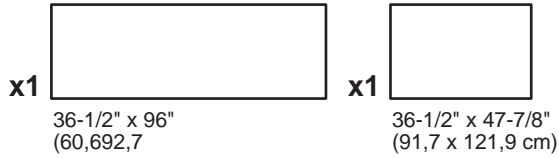

**6** Next, install **36-1/2" x 47-7/8"** and **36-1/2" x 96"** roof panels with a **3/4"** measurement on the rafter (**Fig A**) and flush to the installed panels (**Fig. E**).

Secure panels with (1) 2" nail in each corner.

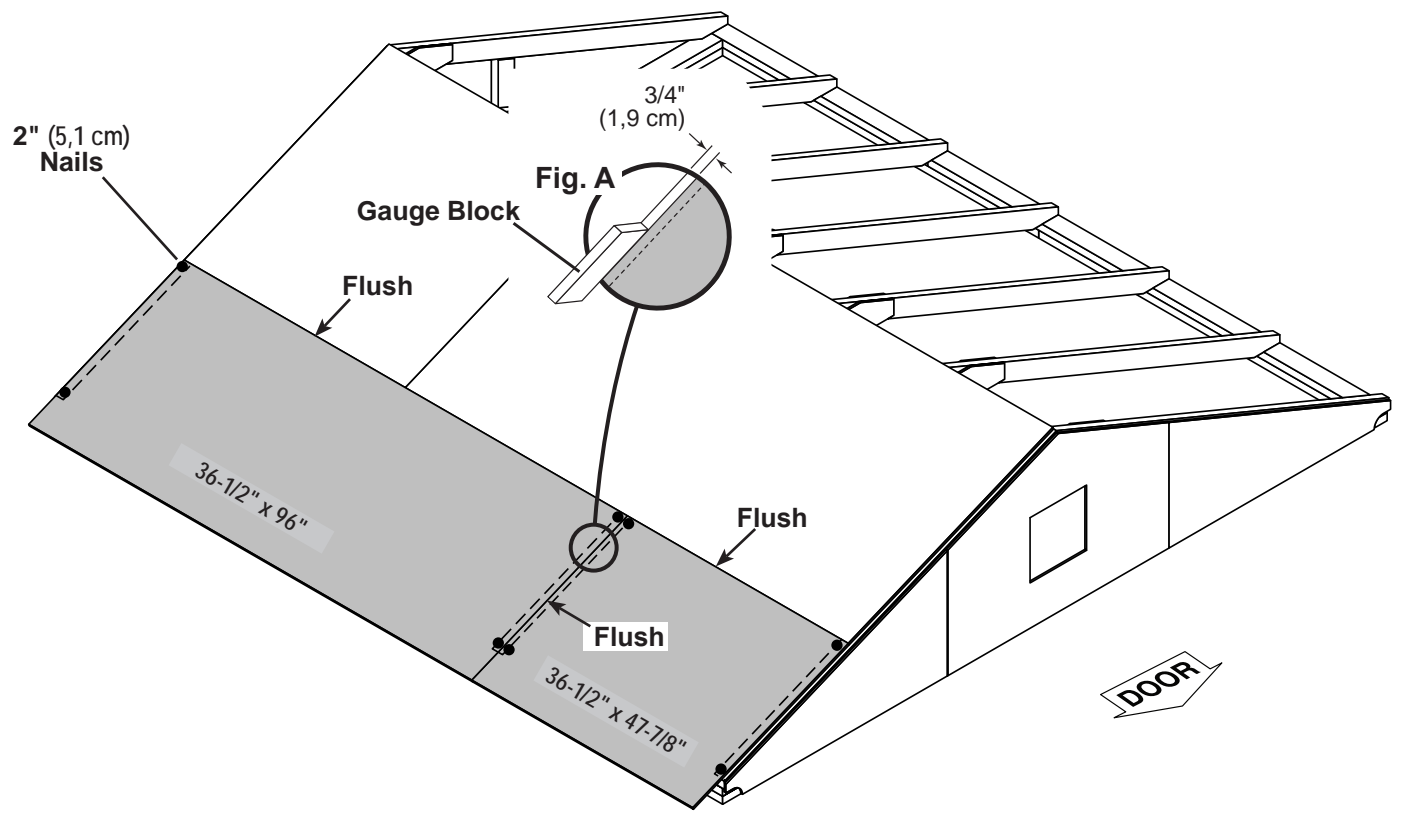

## 12' x 12' ROOF PANELS

### PARTS REQUIRED:

x168

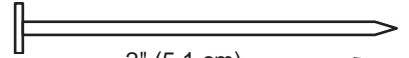

2" (5,1 cm)



- 7 Secure all roof panels with 2" nails spaced 6" apart and 12" apart inside panels.

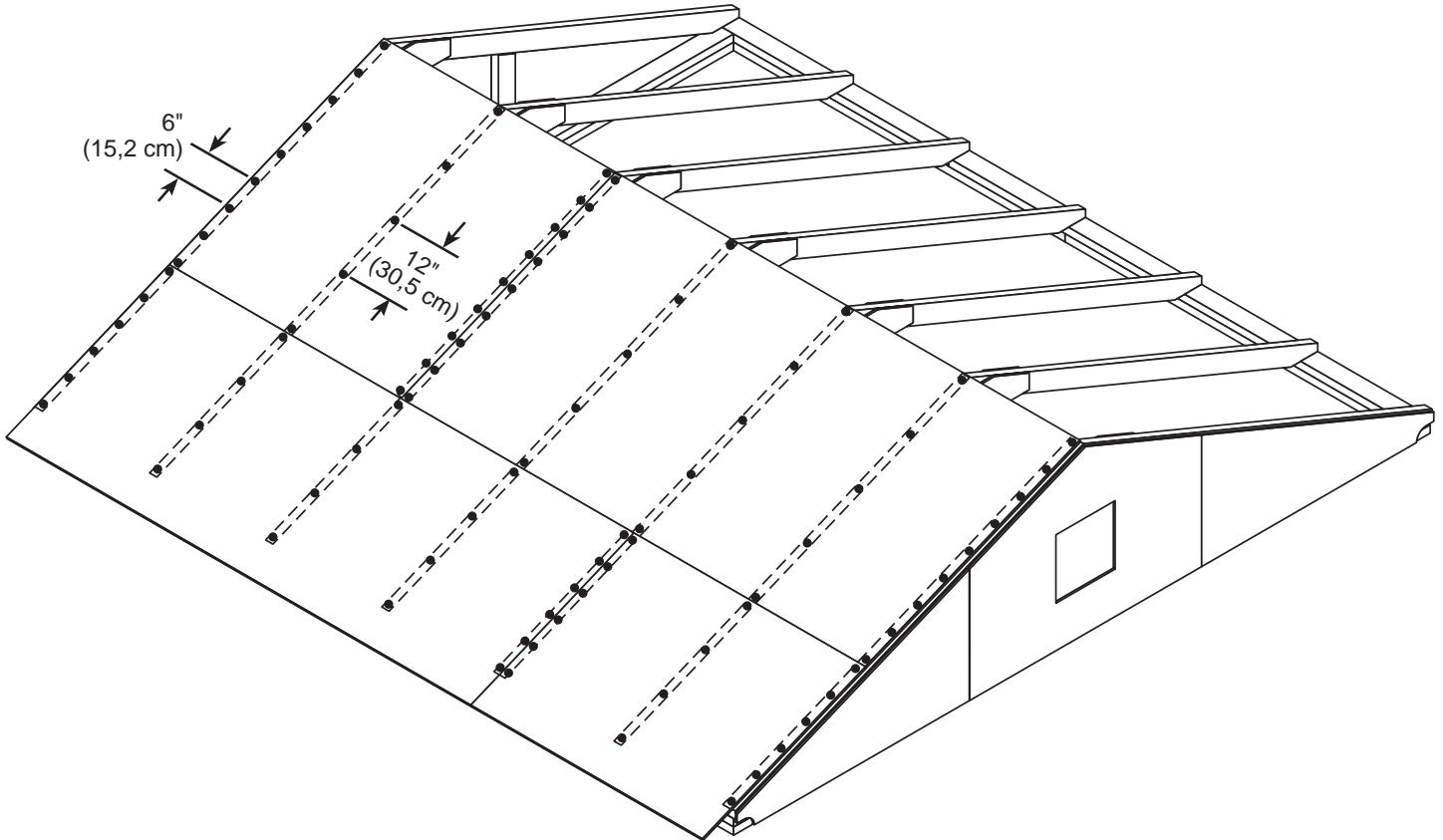

Repeat all steps to install roof panels on the opposite side.

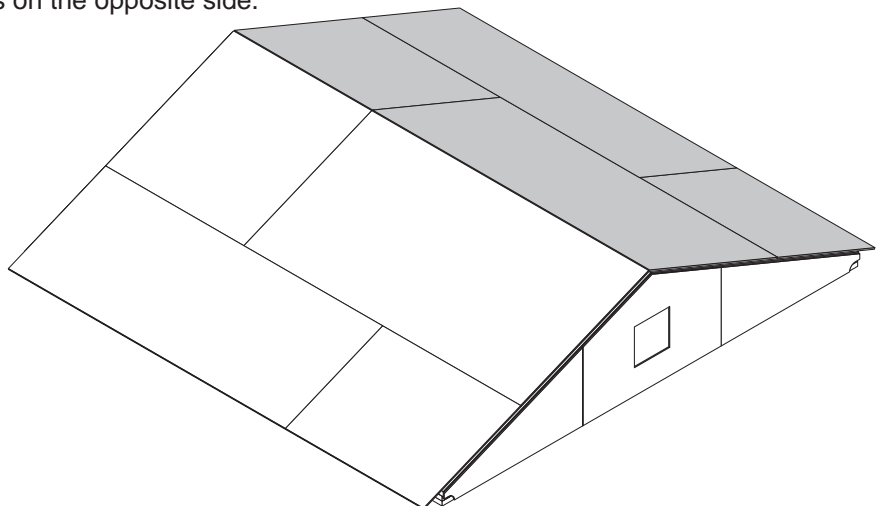

Your roof panels are now installed.

# 12' x 16' ROOF PANELS

## PARTS REQUIRED:

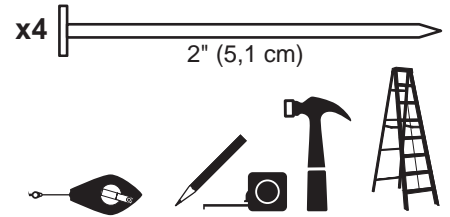

 **Roof panels may cause serious injury until securely fastened.**  
*Note: Install all roof panels with the rough side up (painted grid lines).*

✓ **BEGIN**  
**1**

Place the 48" x 96" panel on rafters with a 3/4" measurement on the rafter (Fig A) and the panel flush at the peak (Fig. B).

Secure panel with (1) 2" nail in each corner.

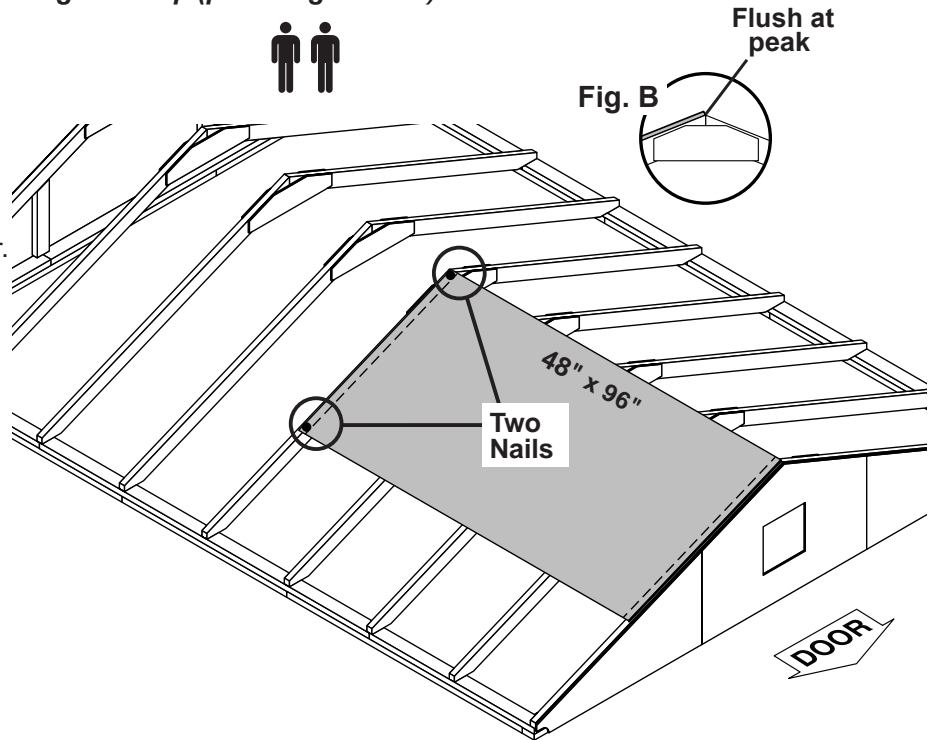
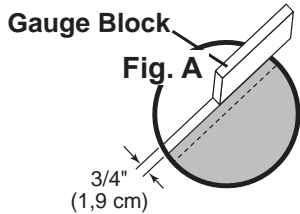

**2**

Move to the opposite end. Using the long edge of the panel as a lever, move the panel side-to-side until the top corner is flush to the peak (Fig. B).

Move gable end rafter edge until it is 1/2" from the panel (Fig. C).

Secure panel with (1) 2" nail in each corner.

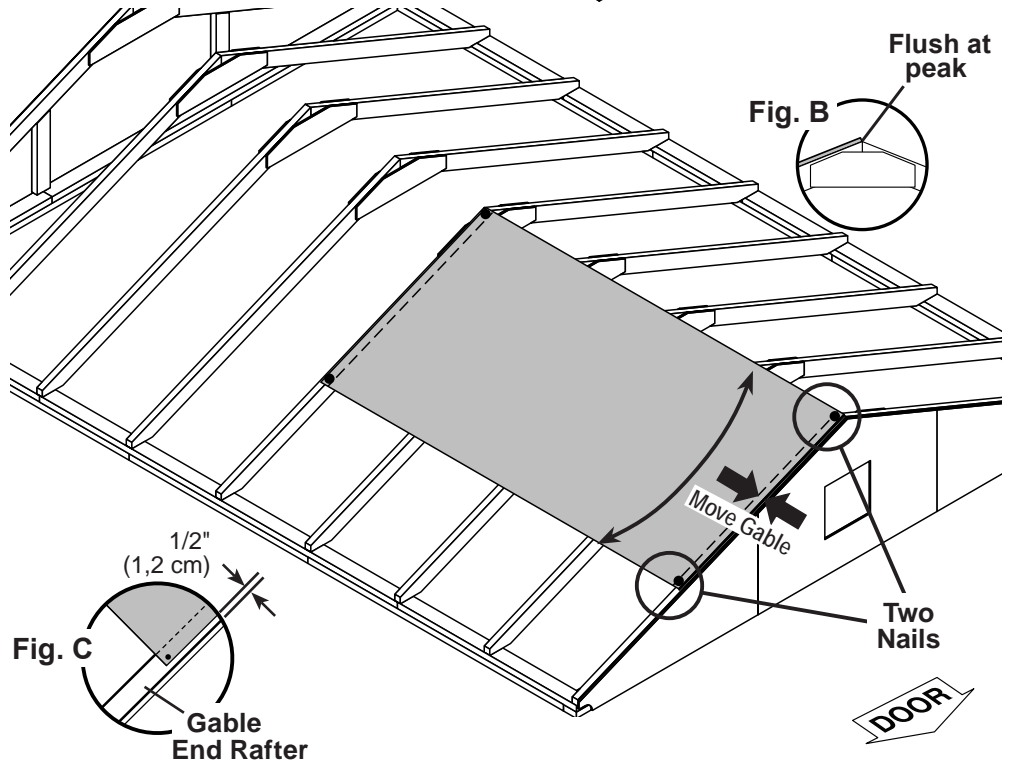

# 12' x 16' ROOF PANELS

## PARTS REQUIRED:



**3**  
Install first  $47\text{-}7/8" \times 48"$  roof panel flush to the installed panel and flush at the peak.  
Secure panel with (1) 2" nail in each corner.

Move to the opposite end.  
Using the unattached end of the panel as a lever, move the panel side-to-side until the top corner is flush to the peak (**Fig. B**) and there is a  $3/4"$  measurement on the rafter (**Fig A**).  
Finish securing panel with (1) 2" nail in each corner.

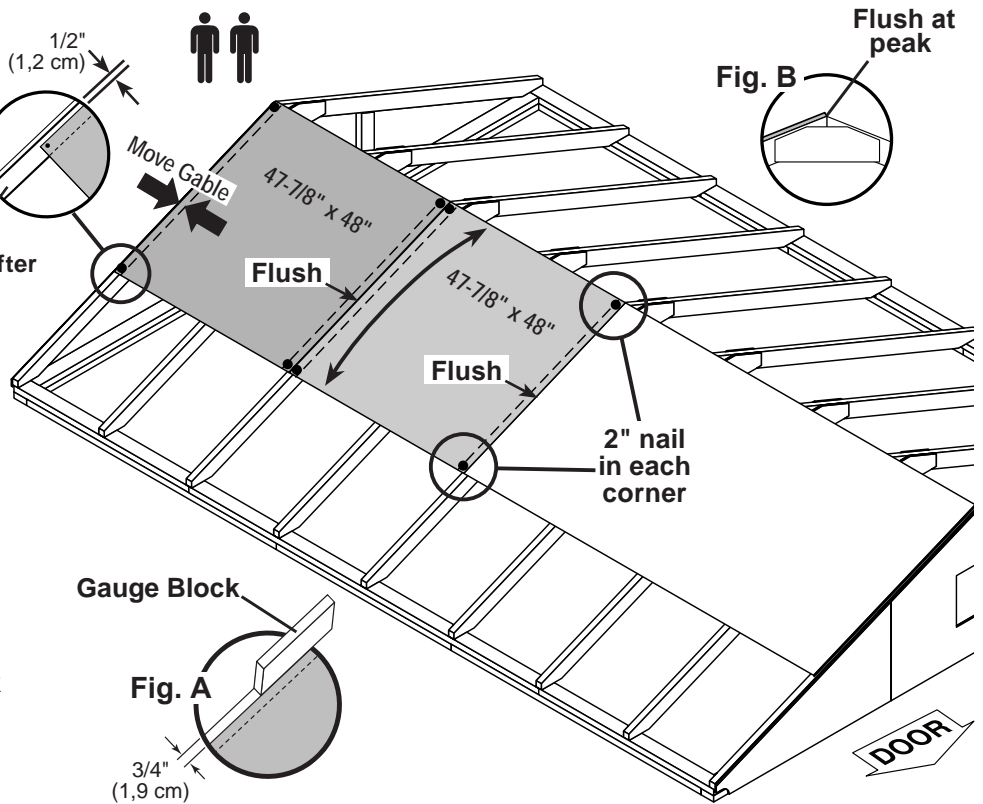

**4**  
Install next  $48" \times 48"$  roof panel flush to the installed panel and flush at the peak (**Fig. B**).  
Secure panel with (1) 2" nail in each corner.

Move gable end rafter edge until it is  $1/2"$  from the 2nd  $48" \times 48"$  roof panel (**Fig. C**).  
Finish securing panel with (1) 2" nail in each corner.

**5**  
Maintain spacing between the center of the rafters at the lower edge of the panels (**Fig. D**).  
Secure panels with (1) 2" nail into each rafter, as shown.  
Move to the top of the panel and keep spacing between the center of the rafters.  
Secure panels with (1) 2" nail into each rafter.

**Fig. D**

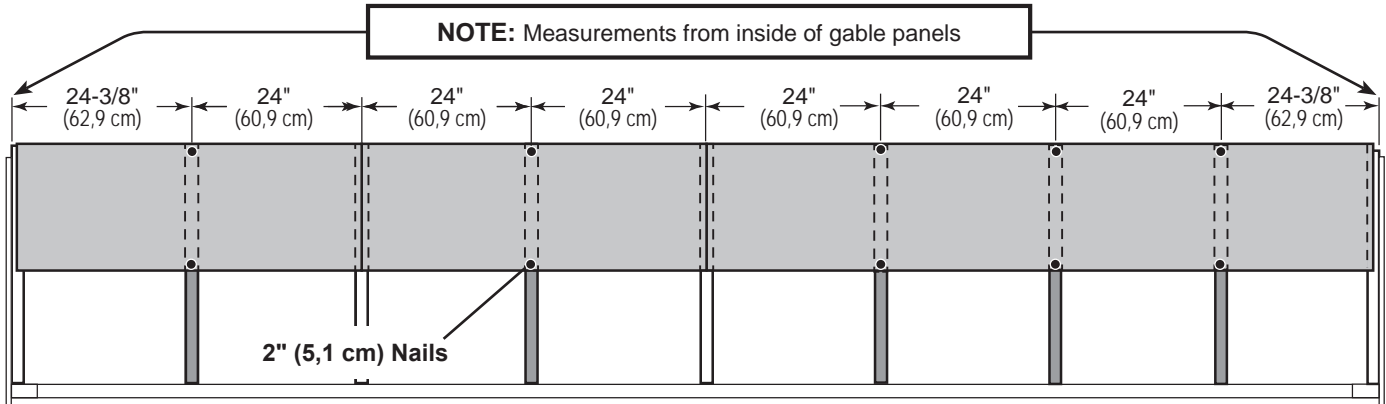

# 12' x 16' ROOF PANELS

## PARTS REQUIRED:

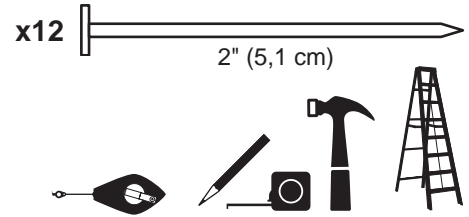
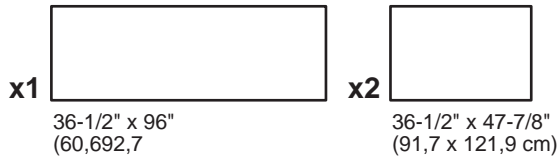

- 6** Next, install **36-1/2" x 96"** with a **3/4"** measurement on the rafter (**Fig A**), and flush to the installed panels. Secure panel with (1) 2" nail in each corner.

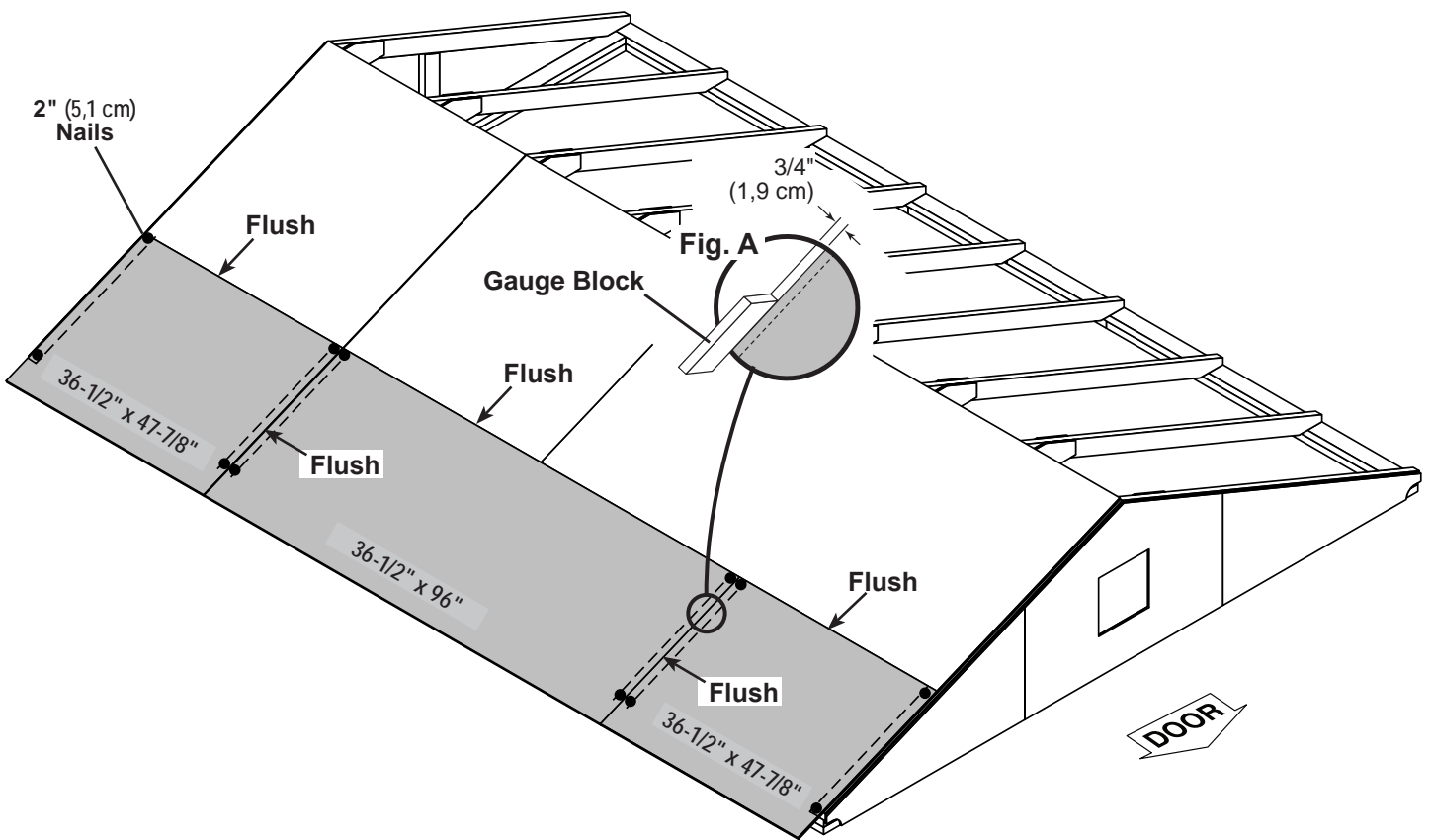

- 7** Instal (2) **36-1/2" x 47-7/8"** roof panels flush to the installed panels in the following order: Secure panels with (1) 2" nail in each corner.

## 12' x 16' ROOF PANELS

### PARTS REQUIRED:

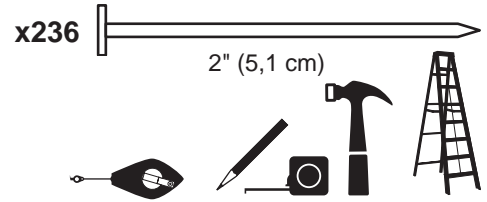

- 8 Secure all roof panels with 2" nails spaced 6" apart and 12" apart inside panels.

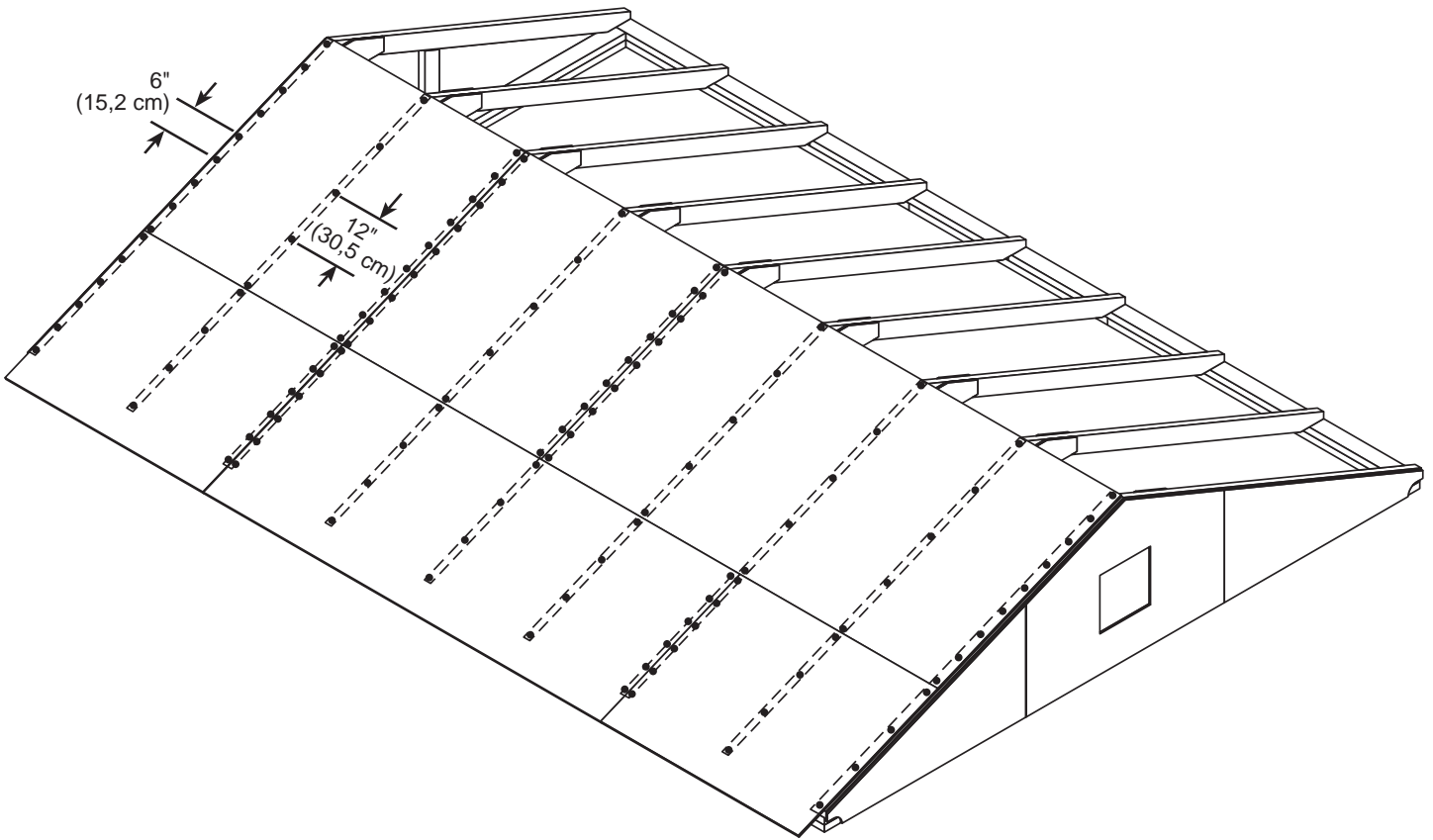

Repeat all steps to install roof panels on the opposite side.

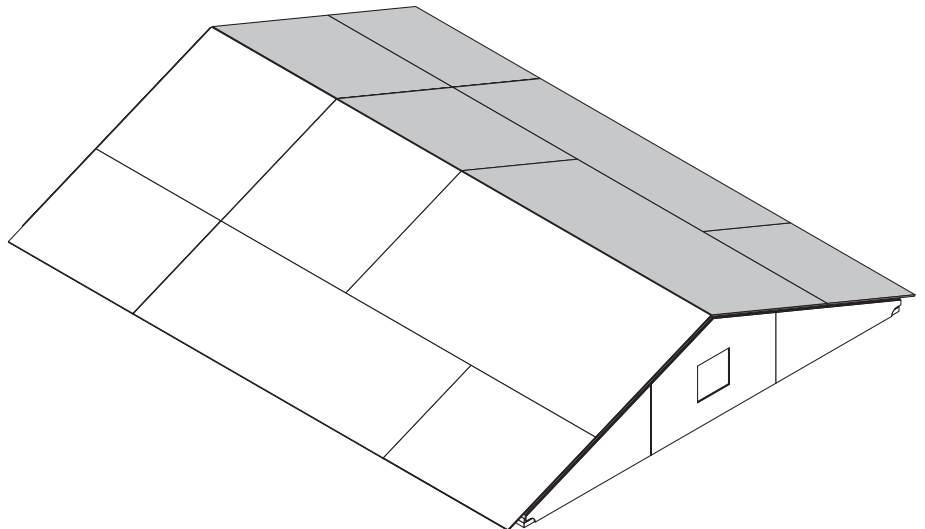

Your roof panels are now installed.

# 12' x 20' ROOF PANELS

## PARTS REQUIRED:

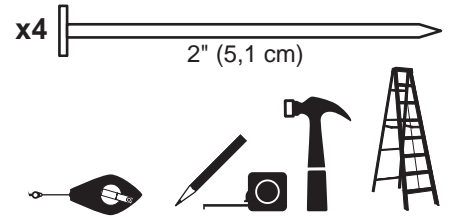

**!** Roof panels may cause serious injury until securely fastened.  
**Note:** Install all roof panels with the rough side up (painted grid lines).



✓ BEGIN

**1**

Place the 48" x 96" panel on rafters with a 3/4" measurement on the rafter (Fig A) and the panel flush at the peak (Fig. B).

Secure panel with (1) 2" nail in each corner.

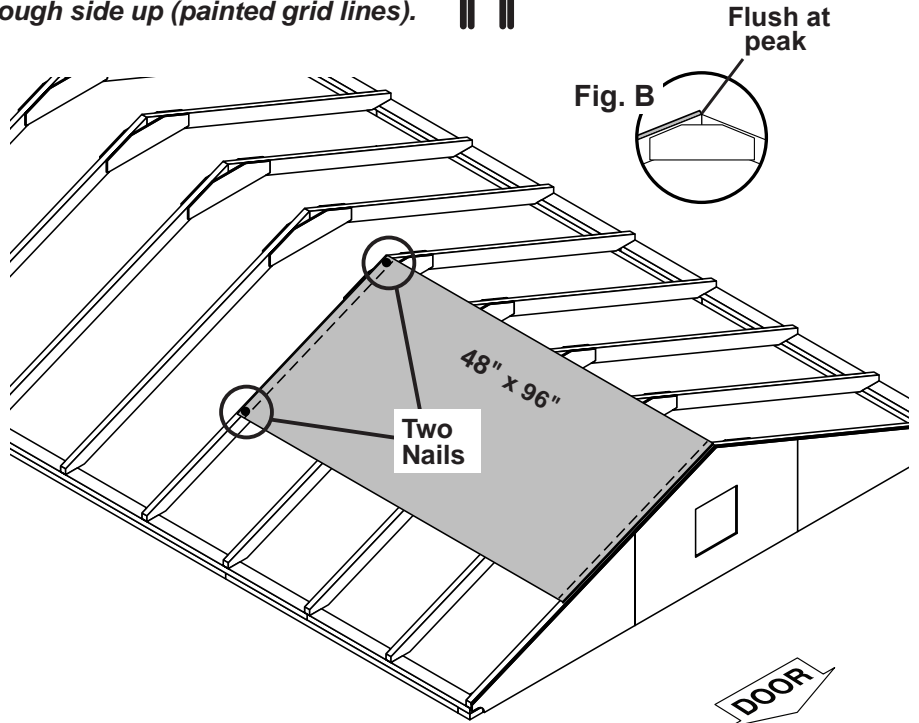
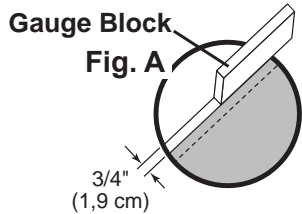

**2**

Move to the opposite end. Using the long edge of the panel as a lever, move the panel side-to-side until the top corner is flush to the peak (Fig. B).

Move gable end rafter edge until it is 1/2" from the panel (Fig. C).

Secure panel with (1) 2" nail in each corner.

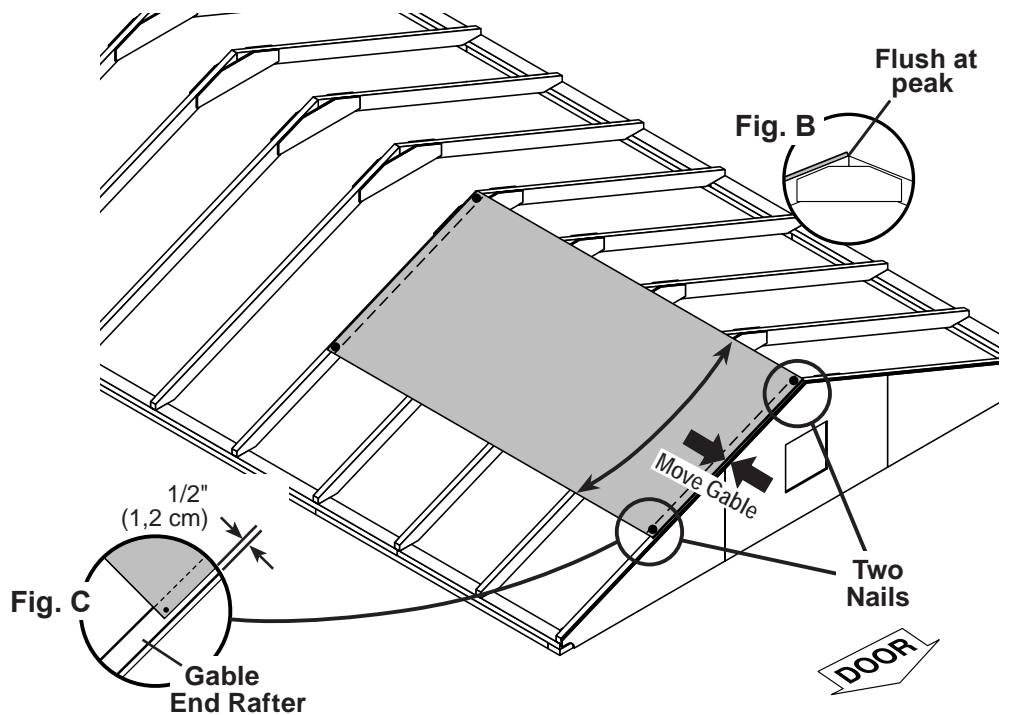

# 12' x 20' ROOF PANELS

## PARTS REQUIRED:



**3**  
Install next 48" x 96" roof panel flush to the installed panel and flush at the peak.  
Secure panel with (1) 2" nail in each corner.

Move to the opposite end.  
Using the unattached end of the panel as a lever, move the panel side-to-side until the top corner is flush to the peak (**Fig. B**) and there is a 3/4" measurement on the rafter (**Fig. A**).  
Finish securing panel with (1) 2" nail in each corner.

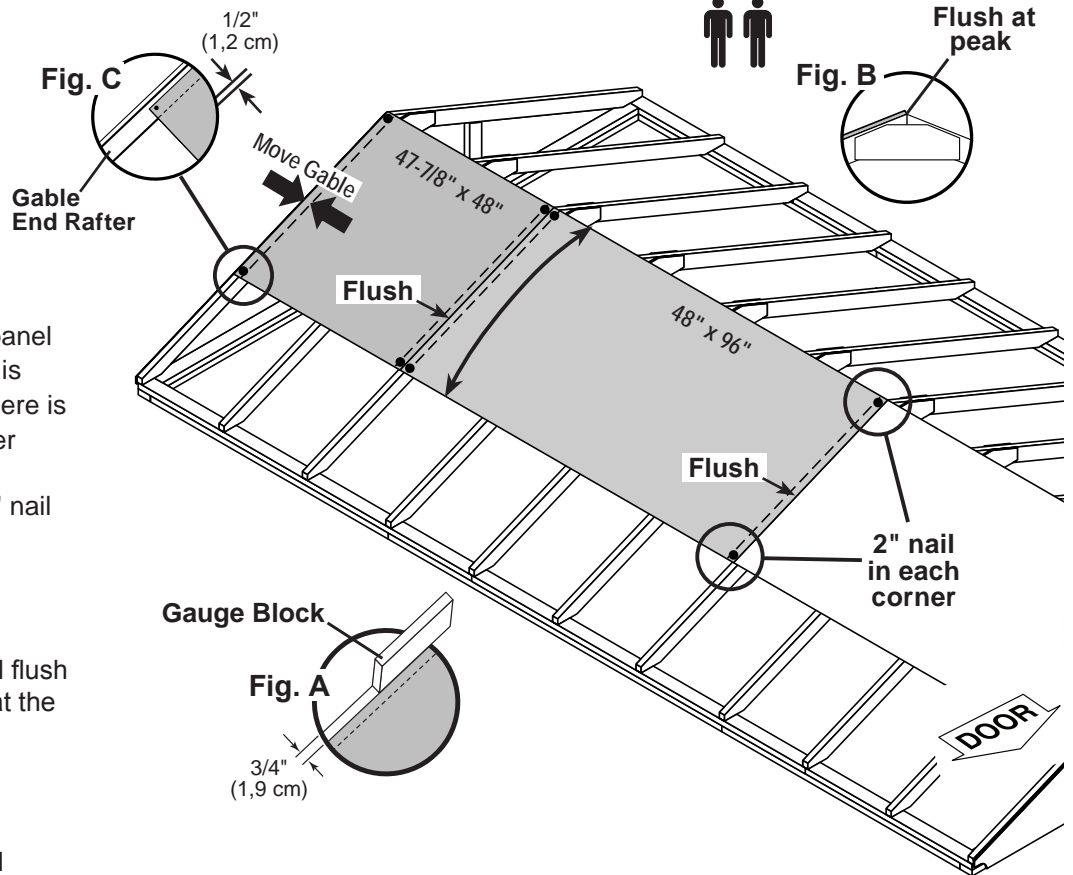

**4**  
Install a 47-7/8" x 48" roof panel flush to the installed panel and flush at the peak (**Fig. B**).  
Secure panel with (1) 2" nail in each corner.

Move gable end rafter edge until it is 1/2" from the roof panel (**Fig. C**).  
Finish securing panel with (1) 2" nail in each corner.

**5**  
Maintain spacing between the center of the rafters at the lower edge of the panels (**Fig. D**).  
Secure panels with (1) 2" nail into each rafter, as shown.  
Move to the top of the panel and keep spacing between the center of the rafters.  
Secure panels with (1) 2" nail into each rafter.

**Fig. D**

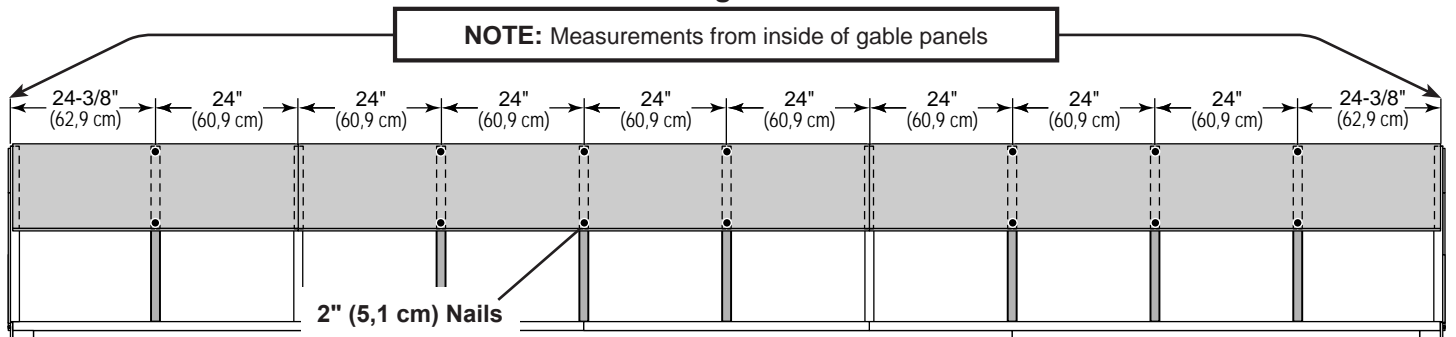

# 12' x 20' ROOF PANELS

## PARTS REQUIRED:

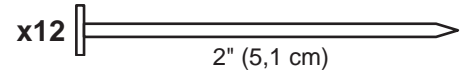
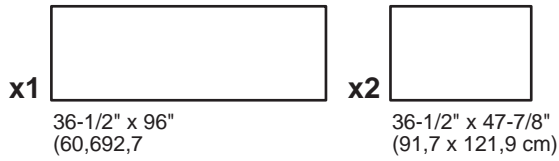

- 6** Next, install **36-1/2" x 96"** roof panel with a 3/4" measurement on the rafter (**Fig A**).  
Secure panel with (1) 2" nail in each corner.

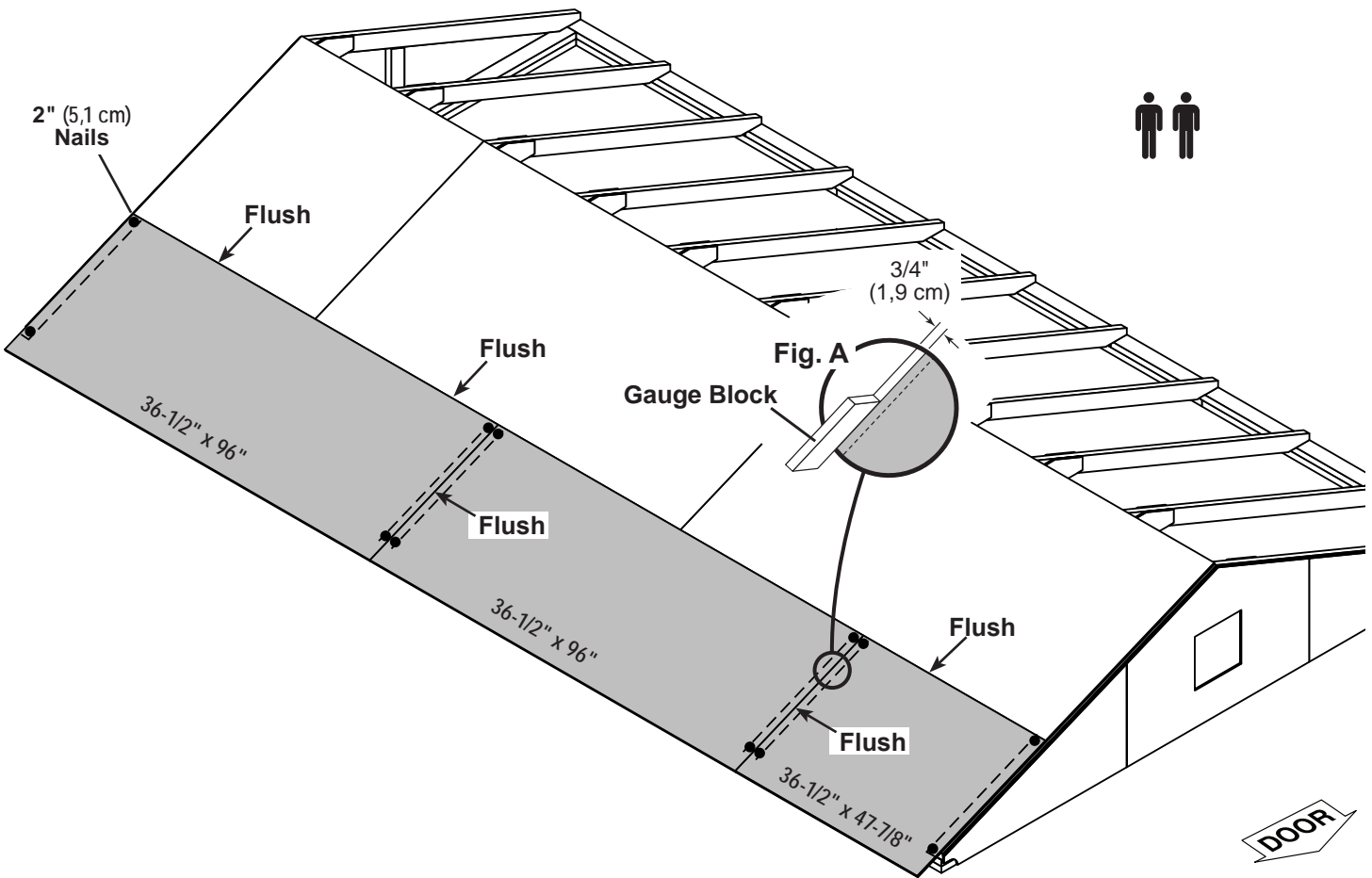

- 7** Install 2nd **36-1/2" x 96"** and **36-1/2" x 47-7/8"** roof panels flush to the installed panels.  
Secure panels with (1) 2" nail in each corner.

## 12' x 20' ROOF PANELS

### PARTS REQUIRED:



- 8 Secure all roof panels with 2" nails spaced 6" apart and 12" apart inside panels.

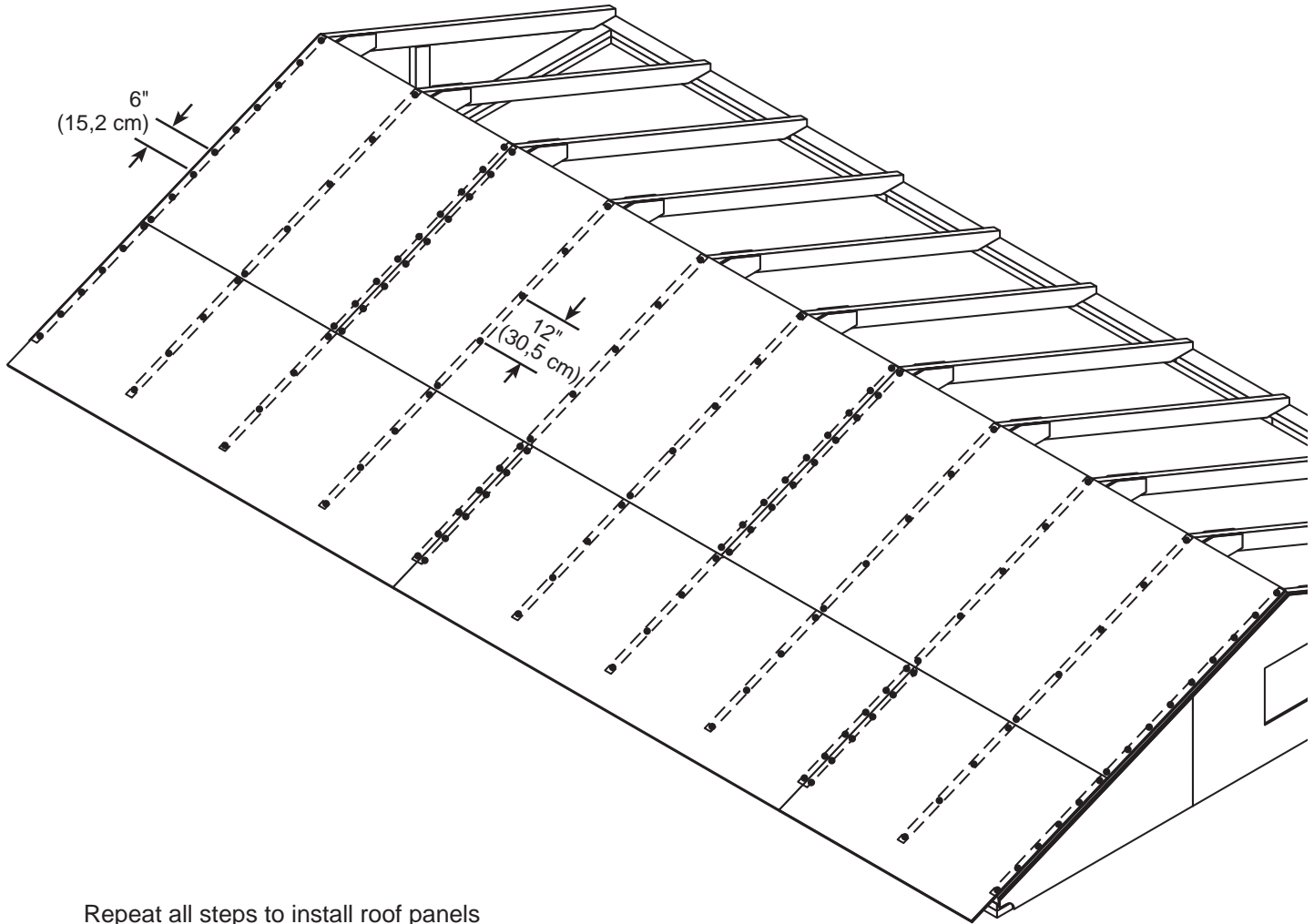

Repeat all steps to install roof panels on the opposite side.

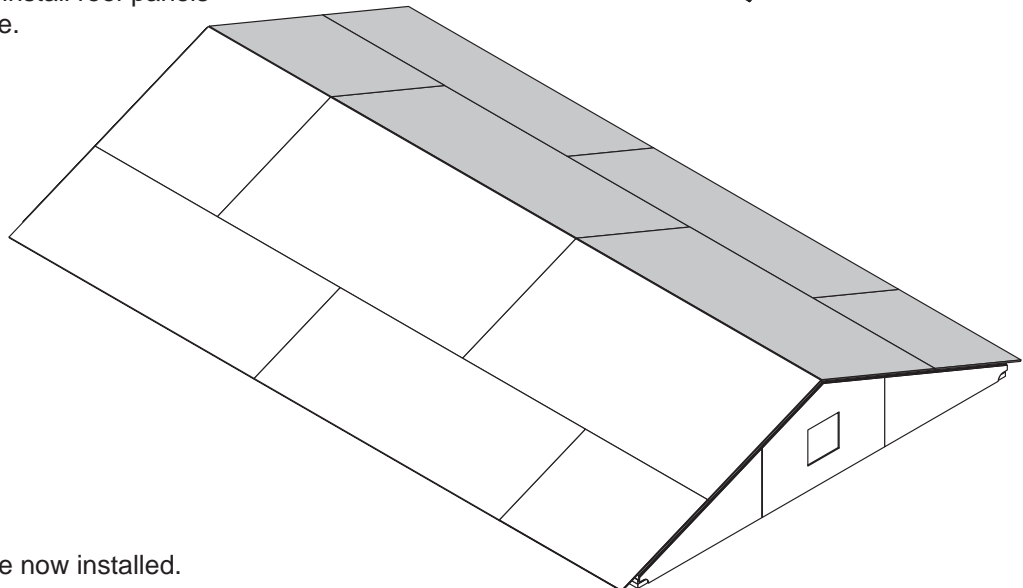

Your roof panels are now installed.

# 12' x 24' ROOF PANELS

## PARTS REQUIRED:

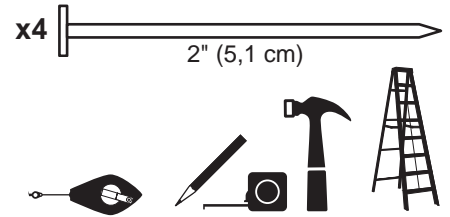

 **Roof panels may cause serious injury until securely fastened.**  
*Note: Install all roof panels with the rough side up (painted grid lines).*

✓ **BEGIN**  
**1**

Place the **48" x 96"** panel on rafters with a **3/4"** measurement on the rafter (**Fig A**) and the panel flush at the peak (**Fig. B**).

Secure panel with (1) 2" nail in each corner.

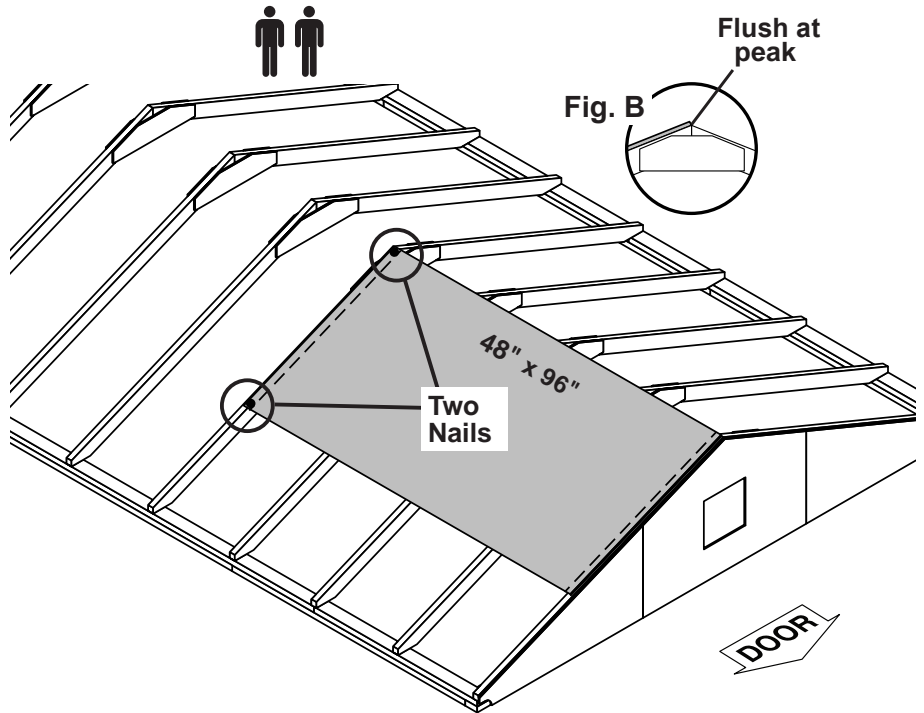
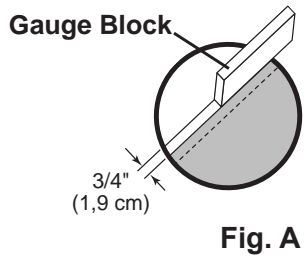

**2**

Move to the opposite end.  
Using the long edge of the panel as a lever, move the panel side-to-side until the top corner is flush to the peak (**Fig. B**).

Move gable end rafter edge until it is 1/2" from the panel (**Fig. C**).

Secure panel with (1) 2" nail in each corner.

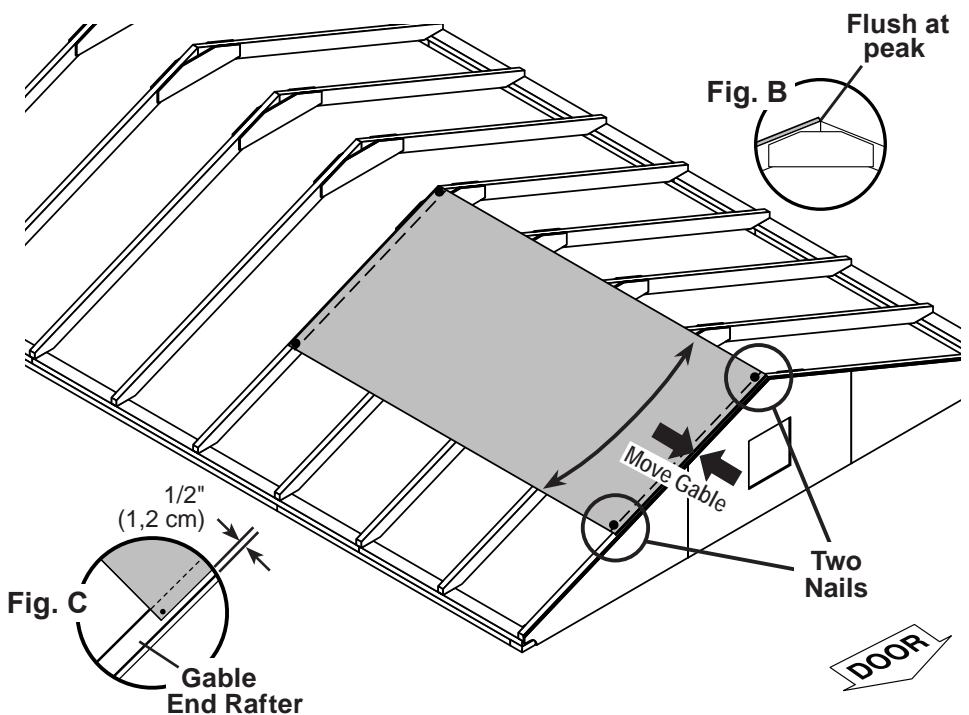

# 12' x 24' ROOF PANELS

## PARTS REQUIRED:

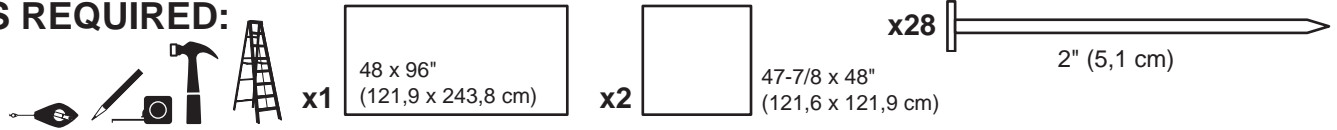

**3**  
Install 2nd 48" x 96" roof panel flush to the installed panel, and flush at the peak (Fig. B). Secure panel with (1) 2" nail in each corner.

Move to the opposite end. Using the unattached end of the panel as a lever, move the panel side-to-side until the top corner is flush to the peak (Fig. B) and there is a 3/4" measurement on the rafter (Fig A). Finish securing panel with (1) 2" nail in each corner.

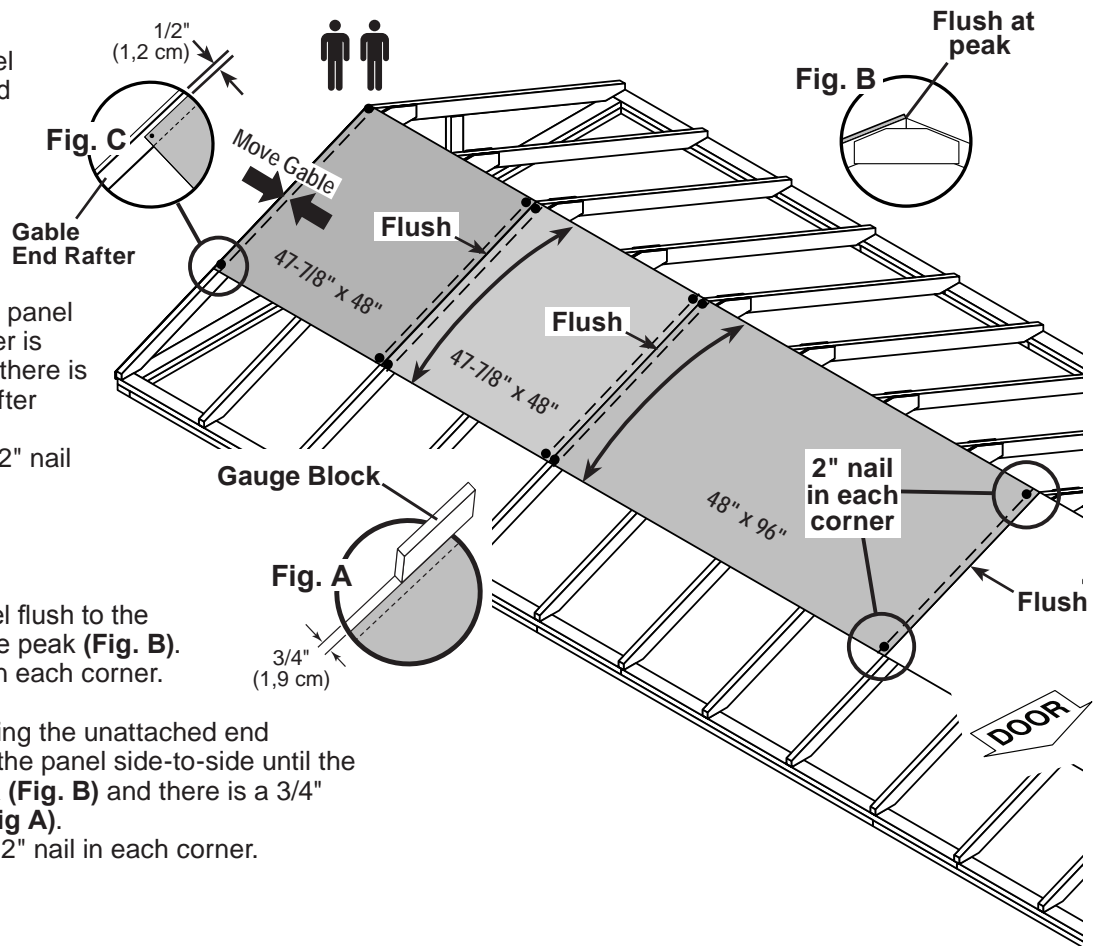

**4**  
Install 47-7/8" x 48" roof panel flush to the installed panel and flush at the peak (Fig. B). Secure panel with (1) 2" nail in each corner.

Move to the opposite end. Using the unattached end of the panel as a lever, move the panel side-to-side until the top corner is flush to the peak (Fig. B) and there is a 3/4" measurement on the rafter (Fig A). Finish securing panel with (1) 2" nail in each corner.

**5**  
Install 47-7/8" x 48" roof panel flush to the installed panel and flush at the peak (Fig. B). Secure panel with (1) 2" nail in each corner.

Move gable end rafter edge until it is 1/2" from the 2nd 48" x 48" roof panel (Fig. C). Finish securing panel with (1) 2" nail in each corner.

**6**  
Maintain spacing between the center of the rafters at the lower edge of the panels (Fig. D). Secure panels with (1) 2" nail into each rafter, as shown. Move to the top of the panel and keep spacing between the center of the rafters. Secure panels with (1) 2" nail into each rafter.

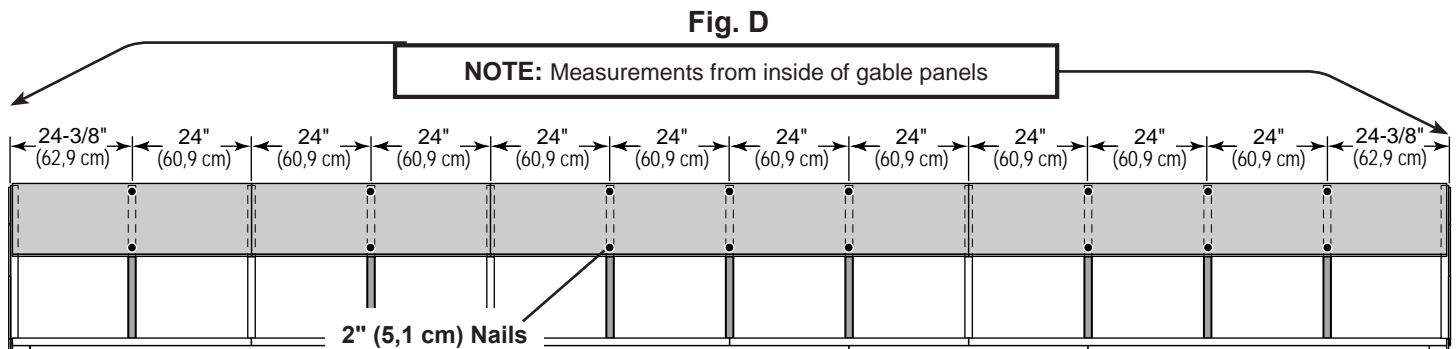

# 12' x 24' ROOF PANELS

## PARTS REQUIRED:

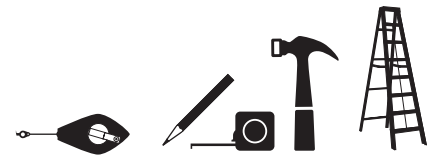
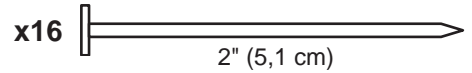
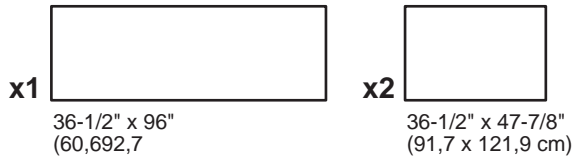

- 7** Install (1) **36-1/2" x 96"** roof panels with a 3/4" measurement on the rafter at each side (**Fig A**), and flush to the installed panels.

Secure panels with (1) 2" nail in each corner.

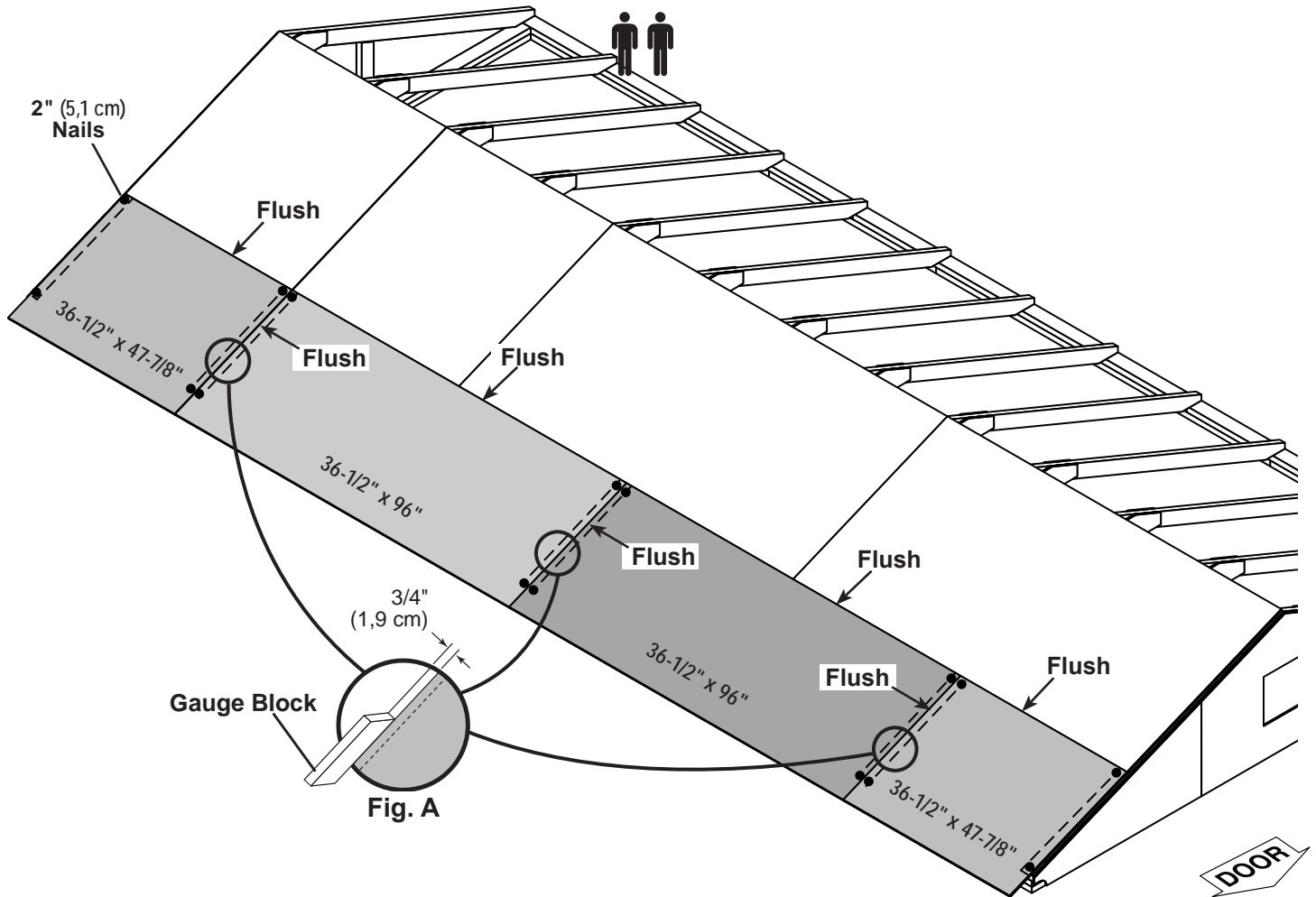

- 8** Install 2nd **36-1/2" x 96"** flush to the installed panels and with a 3/4" measurement on the rafter (**Fig A**). Secure panel with (1) 2" nail in each corner.

Install (2) **36-1/2" x 47-7/8"** roof panels flush to the installed panels..

Secure panels with (1) 2" nail in each corner.

## 12' x 24' ROOF PANELS

### PARTS REQUIRED:



- 9 Secure all roof panels with 2" nails spaced 6" apart and 12" apart inside panels.

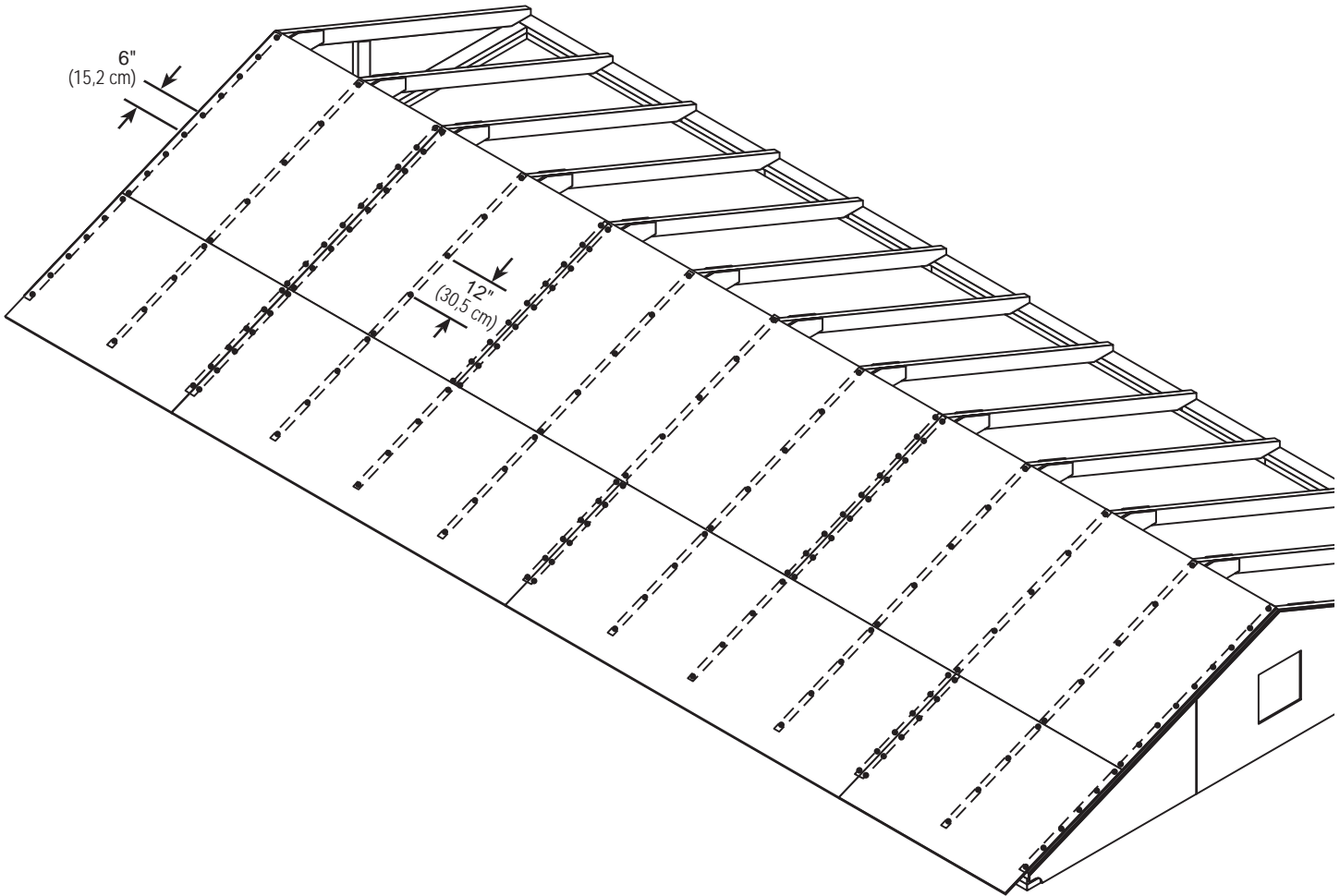

Repeat all steps to install roof panels on the opposite side.

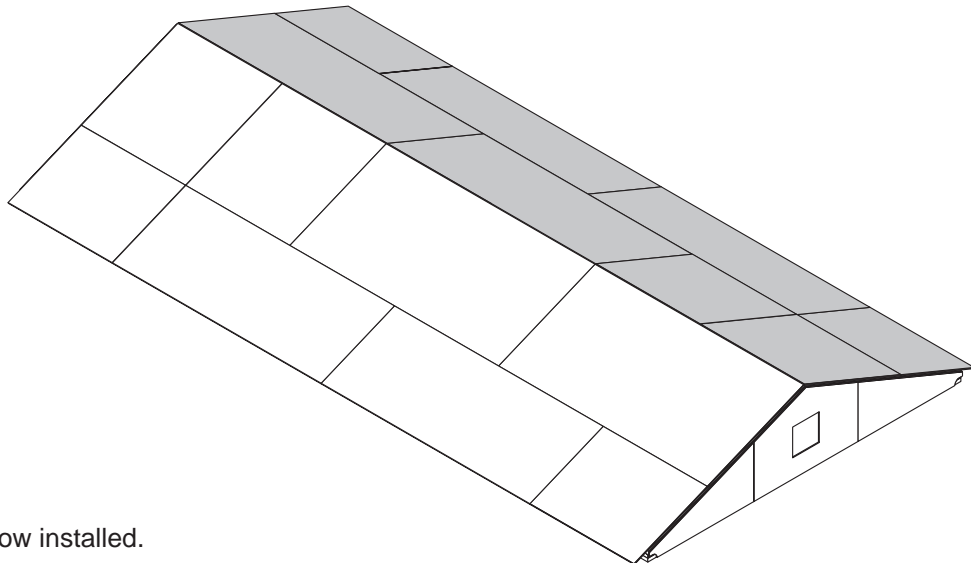

**FINISH**

Your roof panels are now installed.

# GABLE TRIM

## PARTS REQUIRED:

- x2 **CQR**  
19/32" x 3-1/2" x 84-15/16" (1,5 x 8,9 x 215,7 cm)
- x2 **CQL**  
19/32" x 3-1/2" x 84-15/16" (1,5 x 8,9 x 215,7 cm)

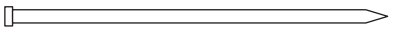
x64  2" (5,1 cm)



✓ **BEGIN**

- 1** Install gable trim **CQR** and **CQL** flush to top of roof panel and flush at peak, as shown.  
Secure trim with 2" finish nails spaced evenly.

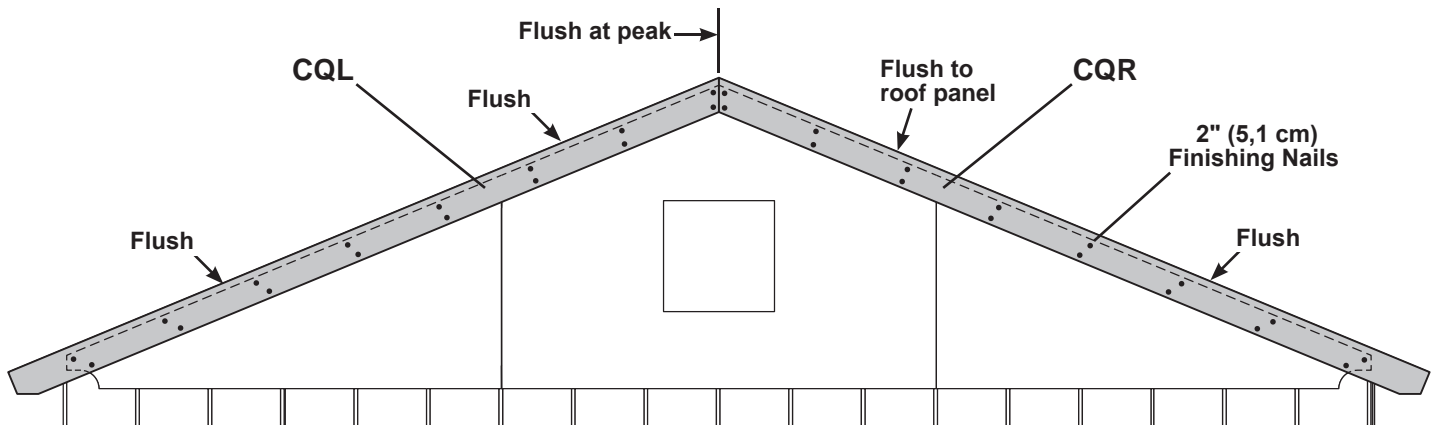

Repeat steps to install trim to the opposite gable.



Your gable trim is now installed.

## 12' x 12' EAVE TRIM

### PARTS REQUIRED:

x2 **WTC**  
2 x 6 x 49-3/4" (5,1 x 15,2 x 126,4 cm)

x2 **VX**  
2 x 6 x 96" (5,1 x 15,2 x 243,8 cm)

x8  x58   
3" (7,6 cm) 1-1/4" (3,2 cm)



### ✓ BEGIN

**1** Place **VX** eave trim flush along edge of roof panel (**Fig. A**).  
Screw through roof panel into trim with 1-1/4" screws spaced evenly in a staggered pattern.

**2** Install **WTC** flush to edge of roof panel and flush to installed eave trim **VX**.  
Screw through roof panel into trim with 1-1/4" screws spaced evenly in a staggered pattern.  
**\*\*Part WTC may need to be trimmed to fit\*\***

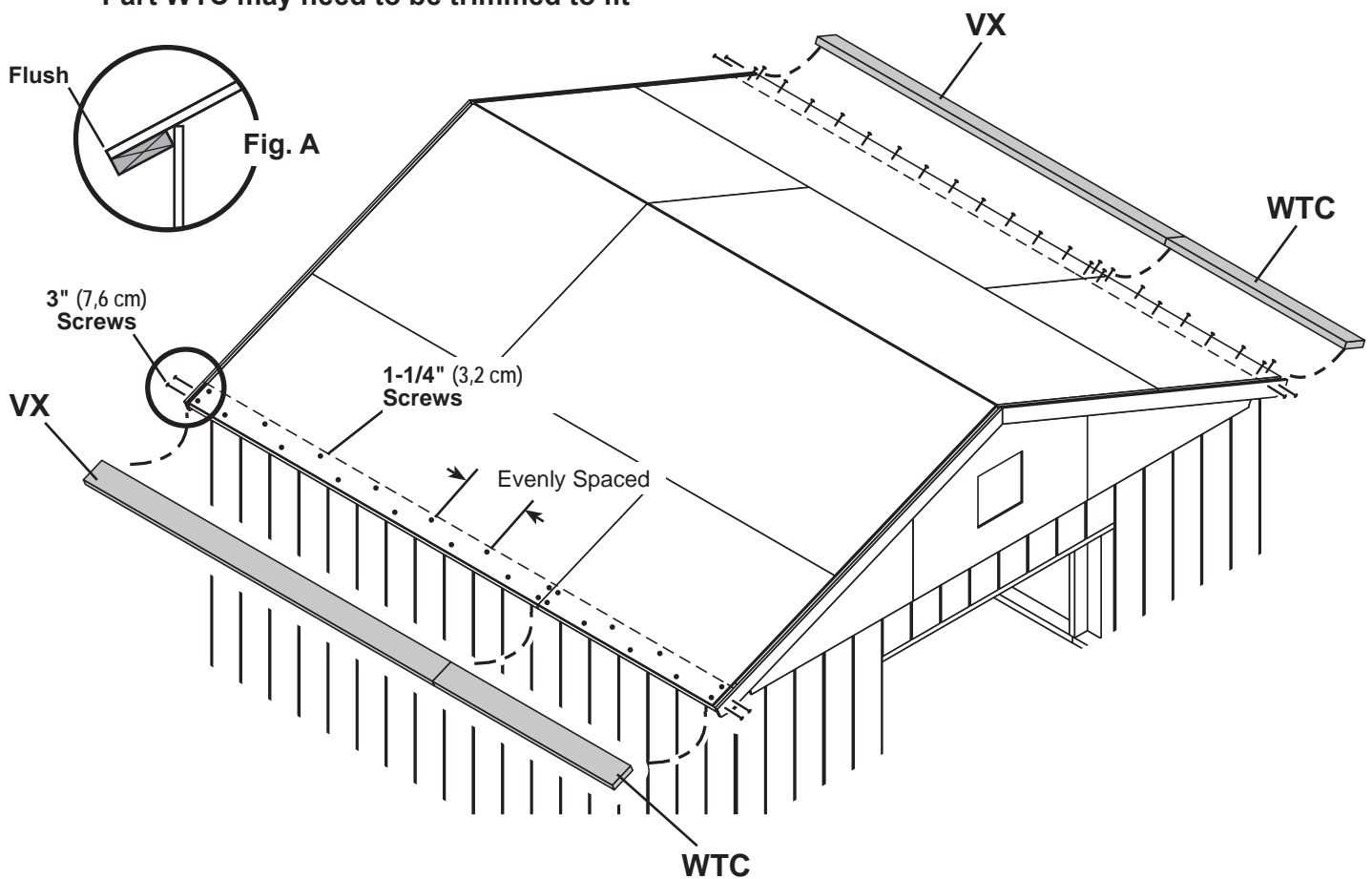

Repeat installation on opposite side.



Your eave trim is now installed.

## 12' x 16' EAVE TRIM

### PARTS REQUIRED:

x2 **VX**  
2 x 6 x 96" (5,1 x 15,2 x 243,8 cm)

x2 **WTC**  
2 x 6 x 49-3/4" (5,1 x 15,2 x 126,4 cm)

x8  3" (7,6 cm)

x2 **VF**  
2 x 6 x 48" (5,1 x 15,2 x 121,9 cm)

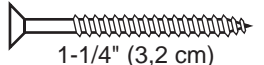
x70  1-1/4" (3,2 cm)



### ✓ BEGIN

- 1 Place **WTC** eave trim flush along edge of roof panel (**Fig. A**) and flush to gable trim. Screw through roof panel into trim with 1-1/4" screws spaced evenly in a staggered pattern.
- 2 Install **VX** flush to edge of roof panel and flush to installed eave trim **WTC**. Screw through roof panel into trim with 1-1/4" screws spaced evenly in a staggered pattern.
- 3 Install **VF** flush to edge of roof panel and flush to installed eave trim **VX**. Screw through roof panel into trim with 1-1/4" screws spaced evenly in a staggered pattern.  
**\*\*Last trim piece may need to be trimmed to fit\*\***

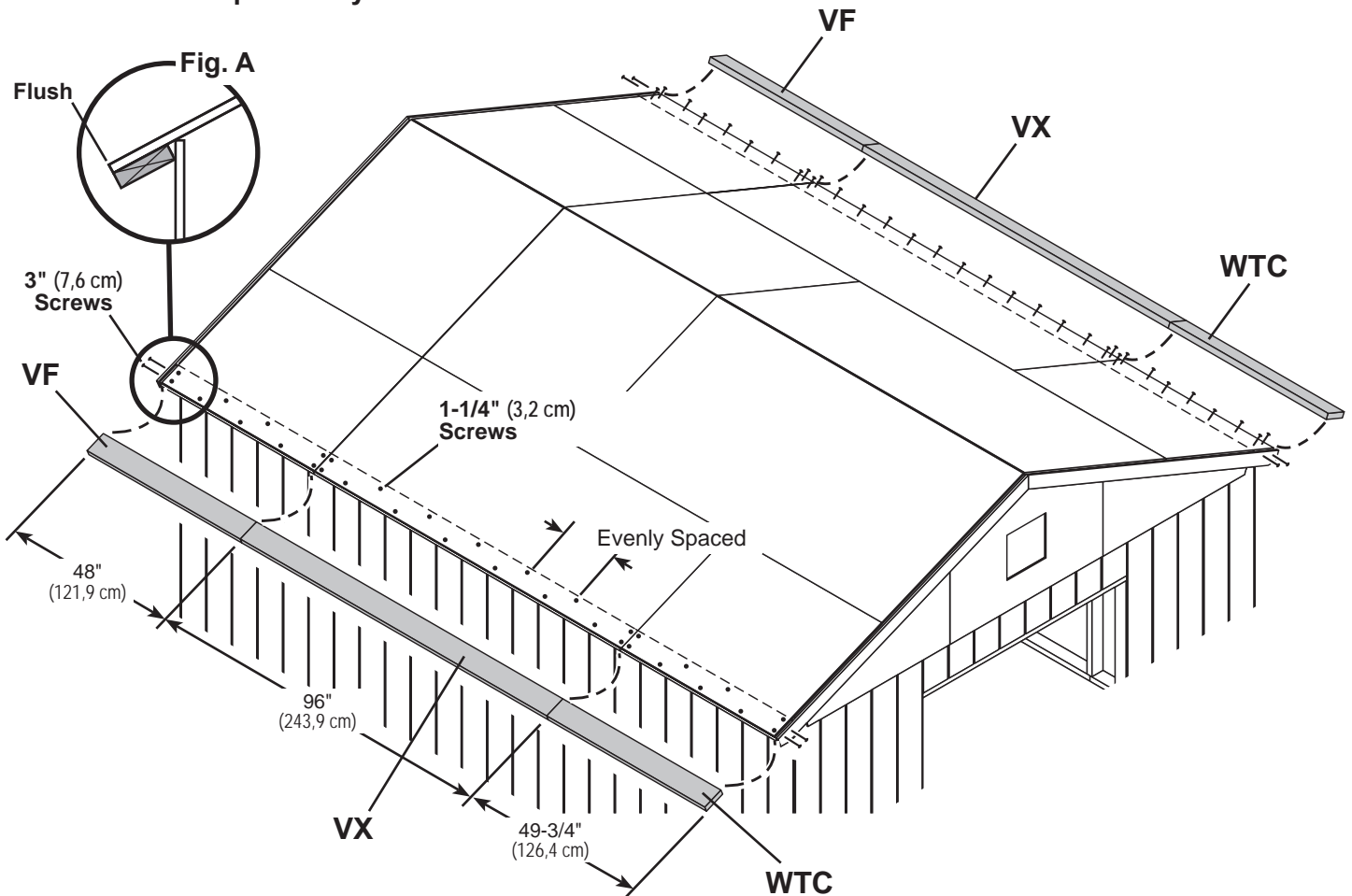

Repeat installation on opposite side.



Your eave trim is now installed.

## 12' x 20' EAVE TRIM

### PARTS REQUIRED:

x2 **WTC**  
2 x 6 x 49-3/4" (5,1 x 15,2 x 126,4 cm)

x2 **VX**  
2 x 6 x 96" (5,1 x 15,2 x 243,8 cm)

x8  3" (7,6 cm) x82  1-1/4" (3,2 cm)



### ✓ BEGIN

- 1 Place **WTC** eave trim flush along edge of roof panel (**Fig. A**) and flush to gable trim.  
Screw through roof panel into **WTC** with 1-1/4" screws spaced evenly in a staggered pattern.
- 2 Install **VX** flush to edge of roof panel and flush to installed eave trim **WTC**.  
Screw through roof panel into trim with 1-1/4" screws spaced evenly in a staggered pattern.
- 3 Install 2nd **VX** flush to edge of roof panel and flush to installed eave trim **VX**.  
Screw through roof panel into trim with 1-1/4" screws spaced evenly in a staggered pattern.  
**\*\*Last trim piece may need to be trimmed to fit\*\***

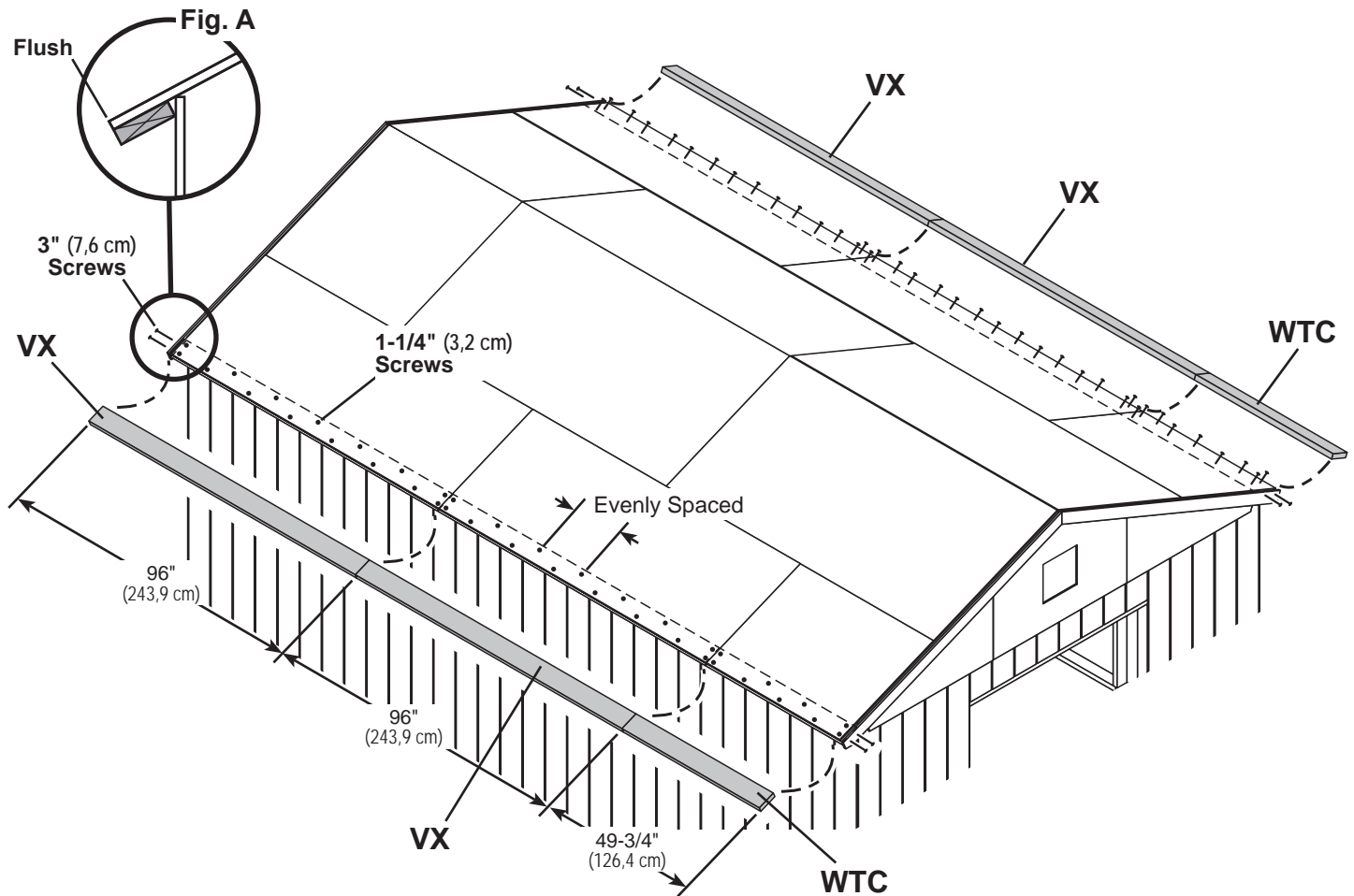

Repeat installation on opposite side.



Your eave trim is now installed.

## 12' x 24' EAVE TRIM

### PARTS REQUIRED:

x4 **VX**  
2 x 6 x 96" (5,1 x 15,2 x 243,8 cm)

x2 **WTC**  
2 x 6 x 49-3/4" (5,1 x 15,2 x 126,4 cm)

x8  3" (7,6 cm)

x2 **VF**  
2 x 6 x 48" (5,1 x 15,2 x 121,9 cm)

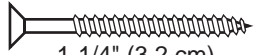
x94  1-1/4" (3,2 cm)



### ✓ BEGIN

- 1 Place **WTC** eave trim flush along edge of roof panel (**Fig. A**) and flush to gable trim.  
Screw through roof panel into trim with 1-1/4" screws spaced evenly in a staggered pattern.
- 2 Install **VX** flush to edge of roof panel and flush to installed eave trim **WTC**.  
Screw through roof panel into trim with 1-1/4" screws spaced evenly in a staggered pattern.
- 3 Install 2nd **VX** flush to edge of roof panel and flush to installed eave trim **VX**.  
Screw through roof panel into trim with 1-1/4" screws spaced evenly in a staggered pattern.
- 4 Install **VF** flush to edge of roof panel and flush to installed eave trim **VX**.  
Screw through roof panel into trim with 1-1/4" screws spaced evenly in a staggered pattern.  
**\*\*Last trim piece may need to be trimmed to fit\*\***

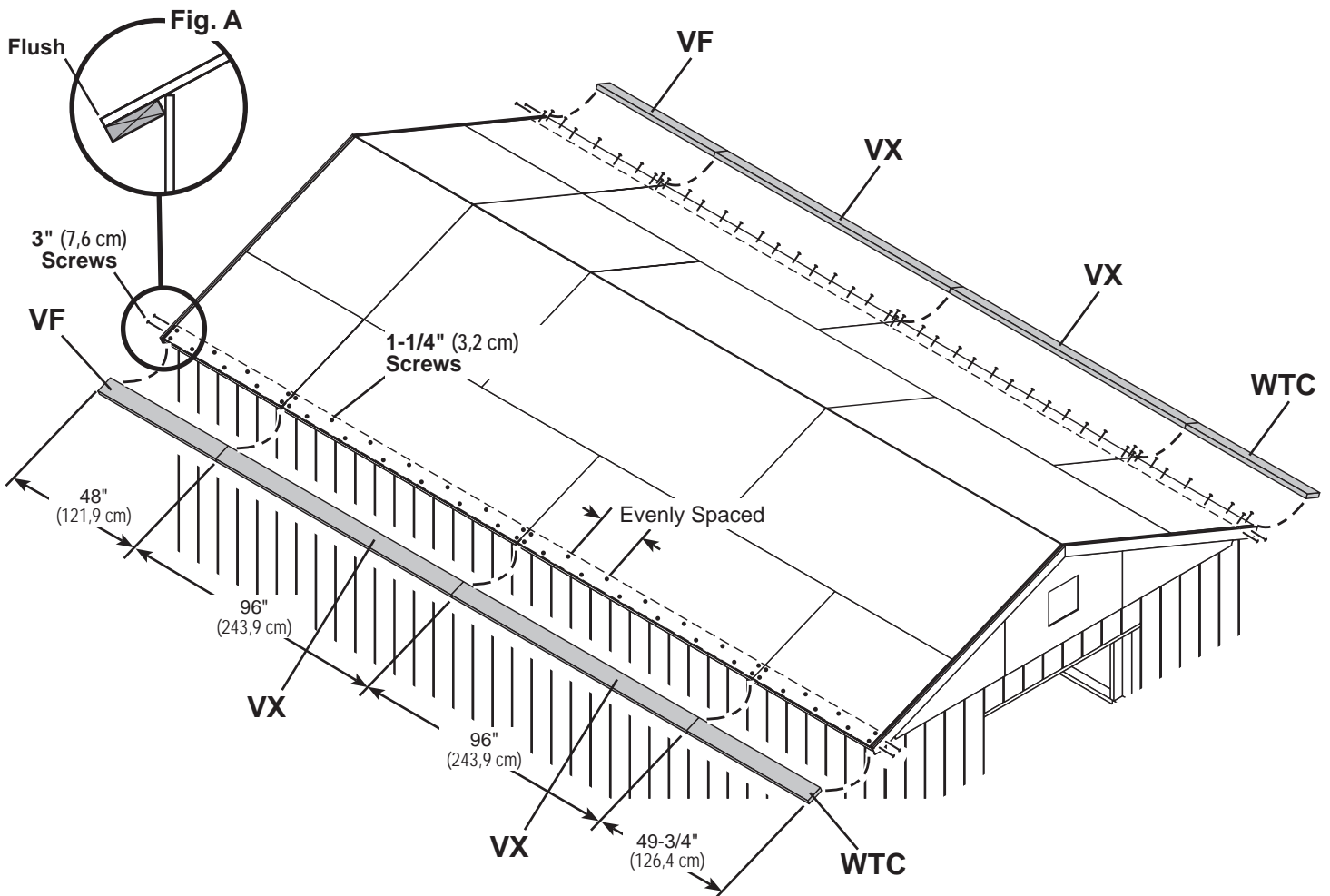

Repeat installation on opposite side.



Your eave trim is now installed.

# CORNER TRIM

## PARTS REQUIRED:

x8   
3/8" x 1-3/4" x 83-1/2" (1 x 4,5 x 212,1 cm)

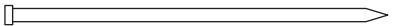
x64   
2" (5,1 cm)

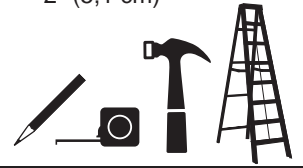

### ✓ BEGIN

- 1 Install gable end **83-1/2"** corner trim under gable panel, (**Fig. A**) and flush to eave wall panel (**Fig. B**). Secure with 2" finishing nails spaced evenly.
- 2 Install eave side **83-1/2"** corner trim flush to eave soffit and flush along seam of installed corner trim (**Fig. C**). Secure with 2" finishing nails spaced evenly.

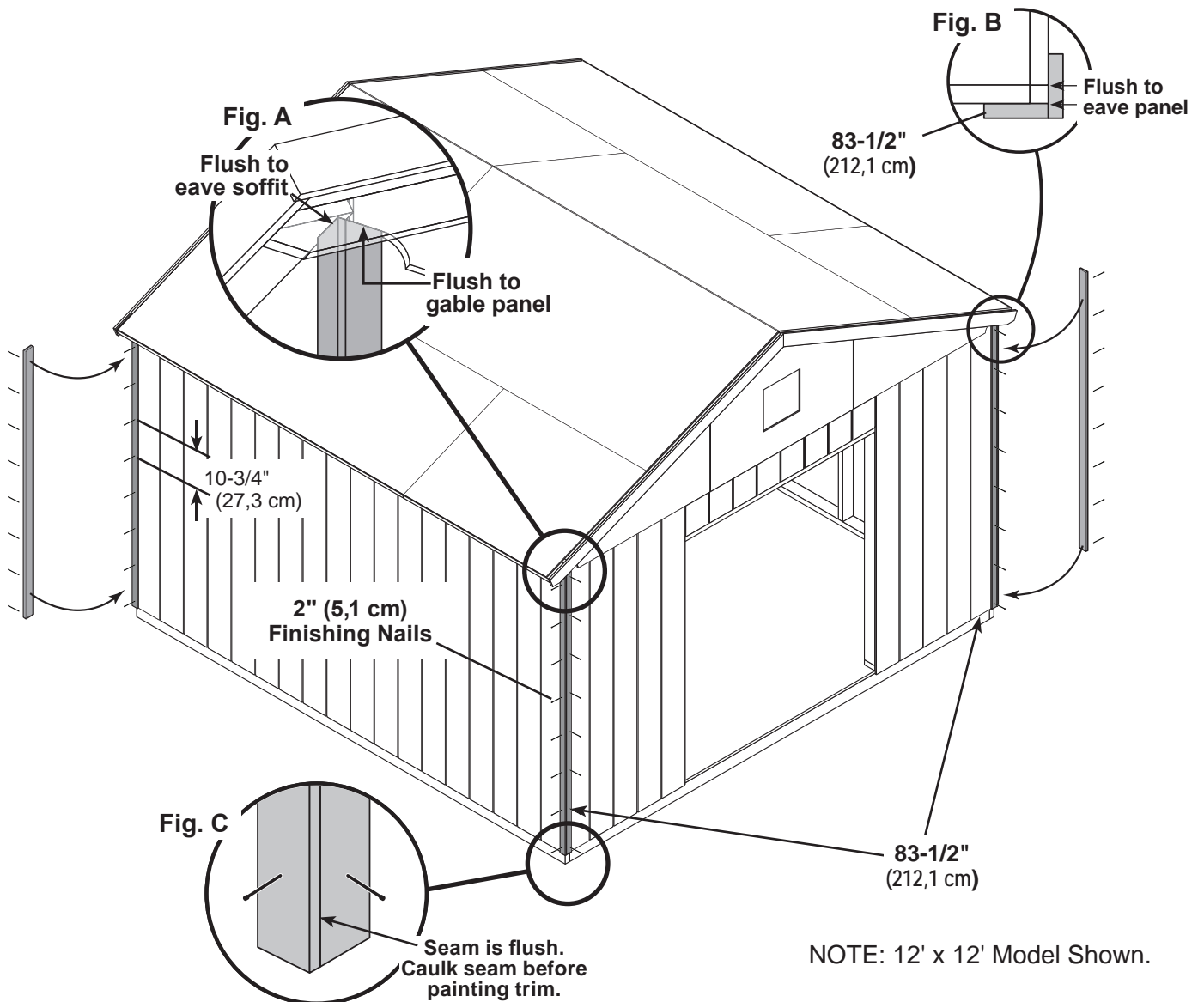

Repeat steps for each corner of shed.



Your corner trim is now installed.

# COLLAR TIE INSTALLATION

12x12' 12x16' 12x20' 12x24'

## PARTS REQUIRED:

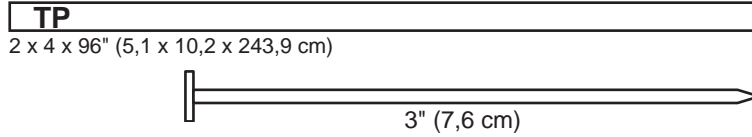

x1	x2	x3	x4
x6	x12	x18	x24

### ✓ BEGIN



- 1 Install collar tie to the rafter with (3) 3" nails at each end (Fig. A).

Starting at the wall with the door, install first collar tie on the 2nd rafter from the wall and then on **every other** rafter, as shown.

Fig. A

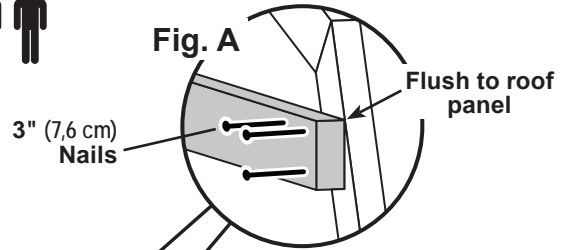

### HINT:

For best appearance, install collar ties on back side of rafter.

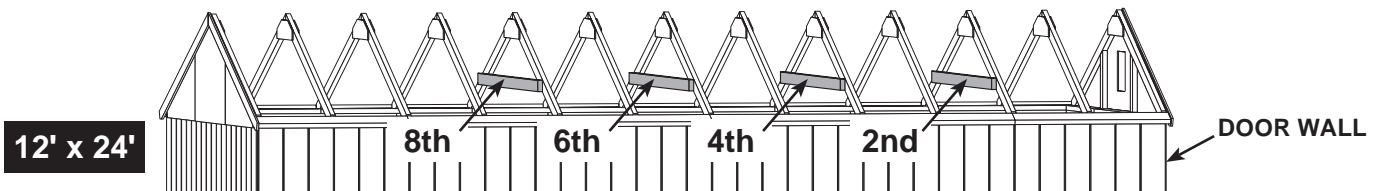
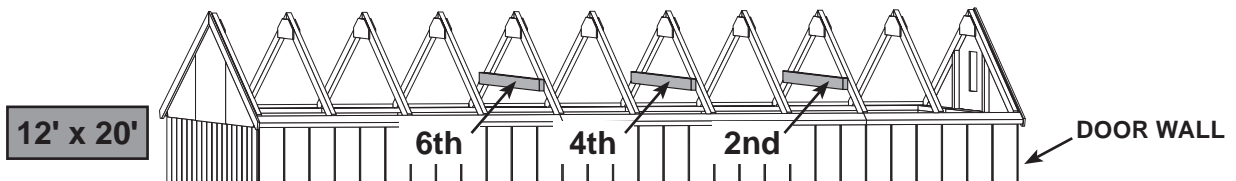
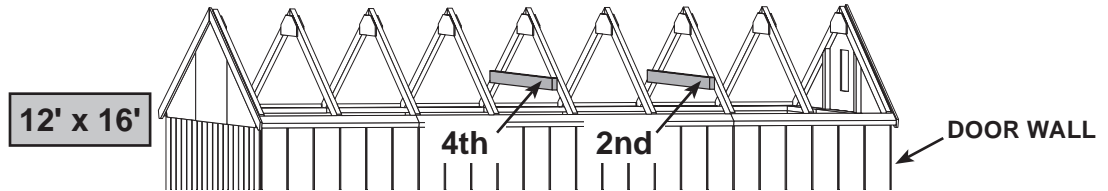
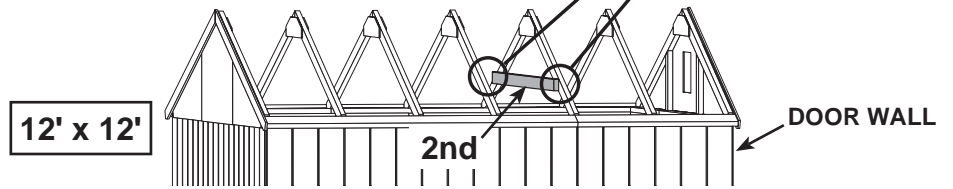

### FINISH

Your collar tie(s) are now installed.

# LOFT JOISTS

## PARTS REQUIRED:

x2 **SP**  
2 x 4 x 48" (5,1 x 10,2 x 121,9 cm)

x2 **TP**  
2 x 4 x 96" (5,1 x 10,2 x 243,8 cm)

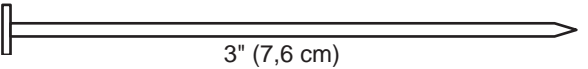
x28  3" (7,6 cm)



### ✓ BEGIN

- 1 Orient parts **TP** and **SP** on a flat surface. Hold parts **TP** and **SP** flush and aligned.

Assemble joist with 3" nails in a staggered pattern.

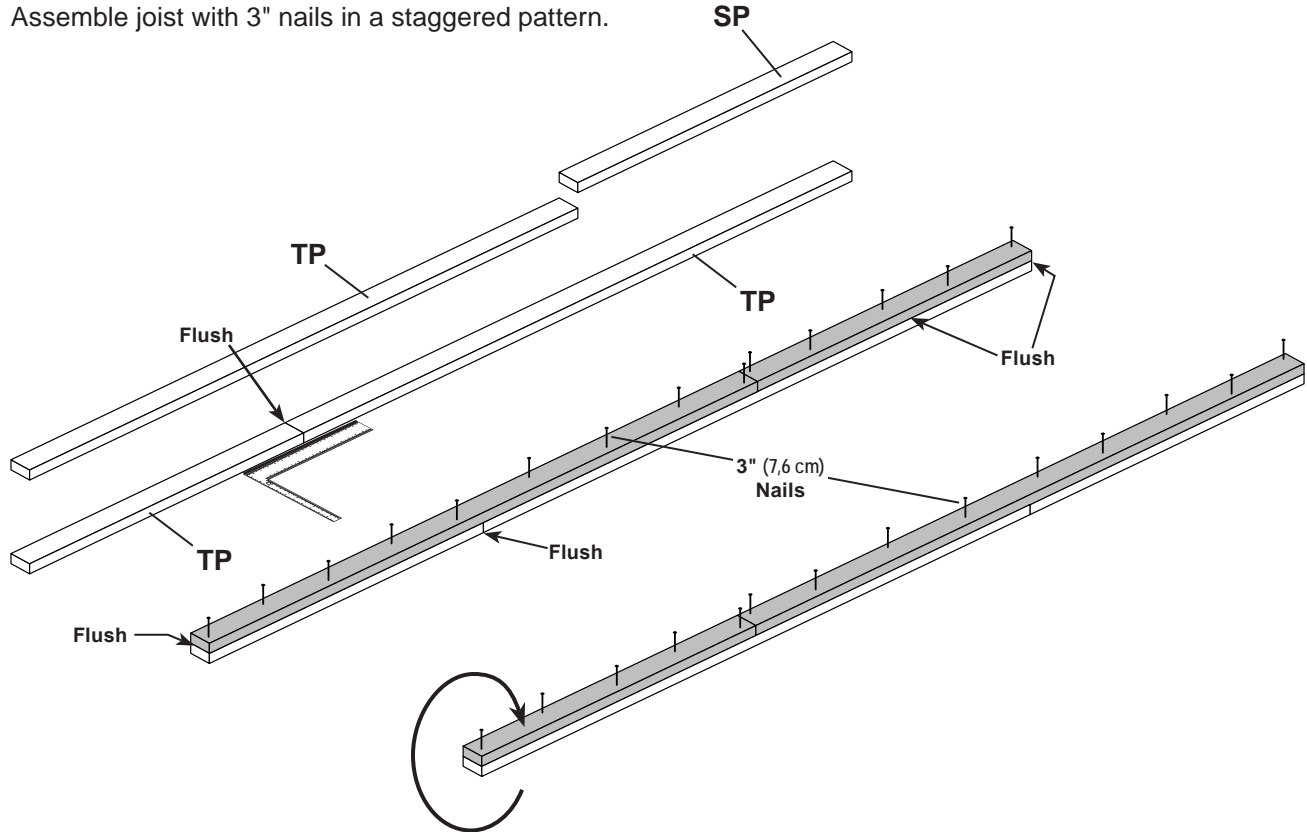

- 2 Turn assembled joist over and repeat staggered nail pattern.

- 3 Support joist and drill a 7/16" hole through each end (**Fig. A**).

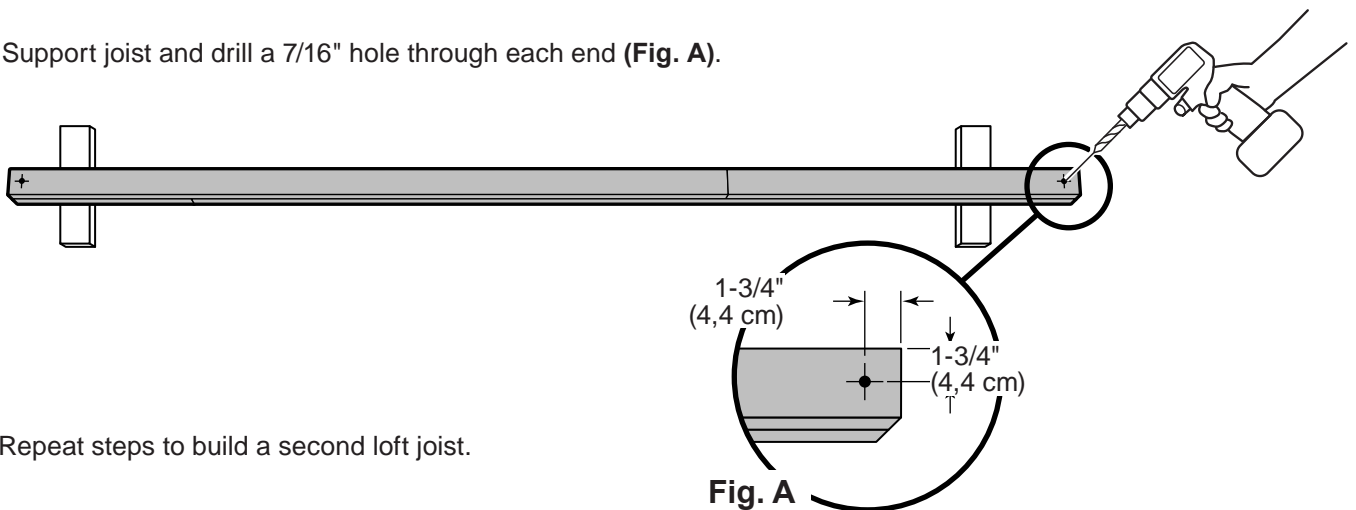

Repeat steps to build a second loft joist.

# LOFT JOIST INSTALLATION

## PARTS REQUIRED:

x1 **NK**  
2 x 3 x 48" (5,1 x 7,6 x 121,9 cm)

x1 **PT**  
2 x 3 x 96" (5,1 x 7,6 x 243,8 cm)

x1 **LOFT JOIST ASSEMBLY**

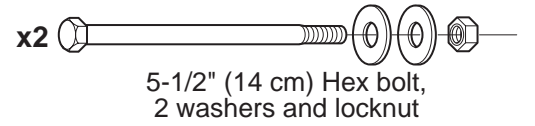
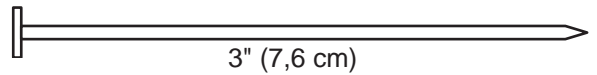
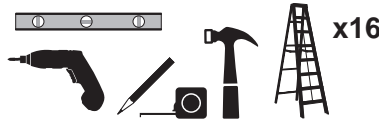

### ✓ BEGIN

- 1 Install **NK** and **PT** flush to bottom of top plate and flush at seam.  
Secure with (2) 3" nails at wall studs and (4) 3" nails at seam.

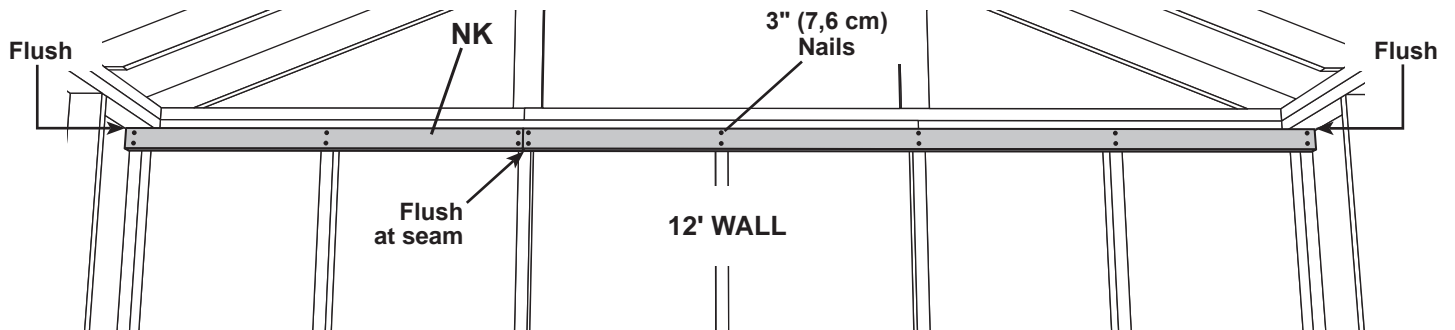

- 2 Clamp or hold joist assembly in place flush to top plate and flush against wall stud.  
Drill through wall stud with 7/16" drill bit using hole in joist assembly as a guide.

- 3 Line up holes of joist assembly with holes in studs.  
Secure joist with hex bolts, flat washers and lock nuts at both sides (**Fig. A**).

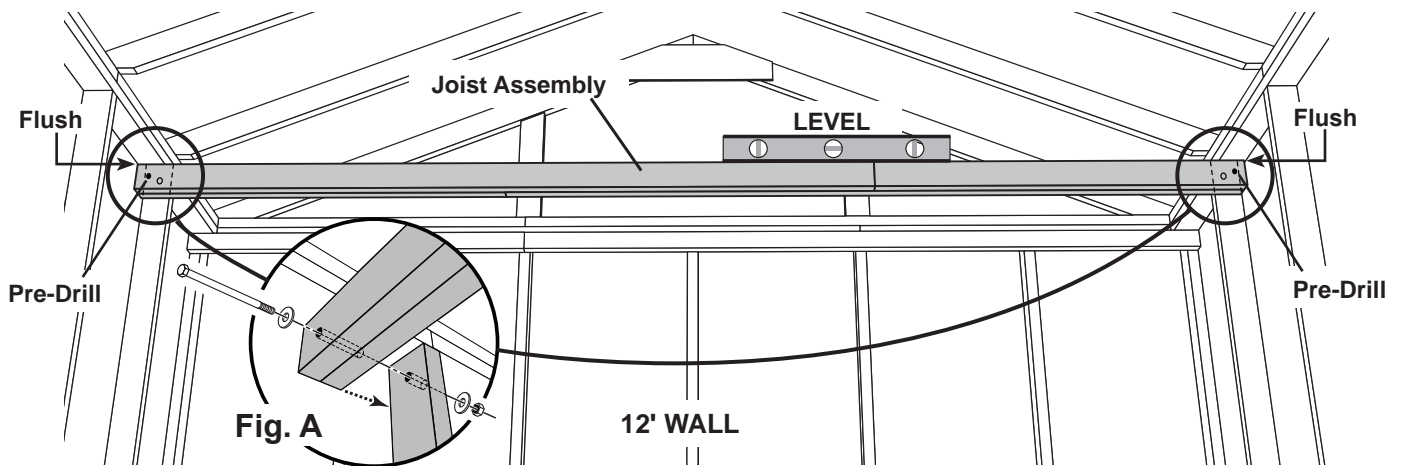

Your loft supports are now installed.

## LOFT PANELS

### PARTS REQUIRED:

x1



23-7/8" x 40-7/8" (60,6 x 103,8 cm)

x1

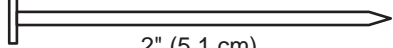

23-7/8" x 96" (60,6 x 244 cm)

x34  2" (5,1 cm)



**BEGIN**

- 1 Install loft panels centered over loft joists and ledger board. Secure with 2" nails spaced 8" (20 cm) apart.

**NOTE:** There will be a gap of approximately 1/2" (13 mm) on either side of installed deck panels.

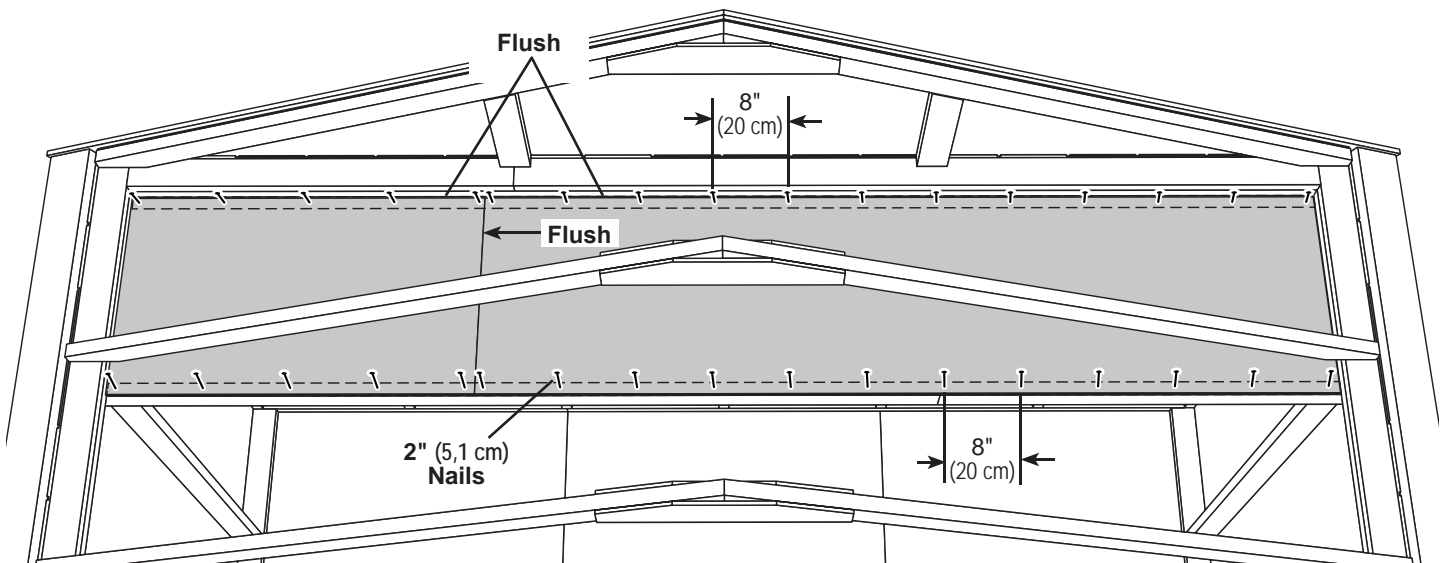



**FINISH**

Your loft panels are now installed.

# SHELF ASSEMBLY AND INSTALLATION

## PARTS REQUIRED:

x14   
 3/8 x 8 x 12-1/2" (1 x 20,3 x 31,8 cm)

x14 **AC**   
 2 x 3 x 10" (5,1 x 7,6 x 25,4 cm)

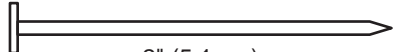
x84   
 2" (5,1 cm)

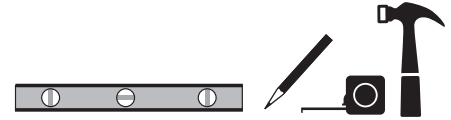

### ✓ BEGIN

- Secure **AC** to shelf panels with (3) 2" nails.  
 Assemble (14) shelf supports as shown; 10 left-side, 4 right-side.

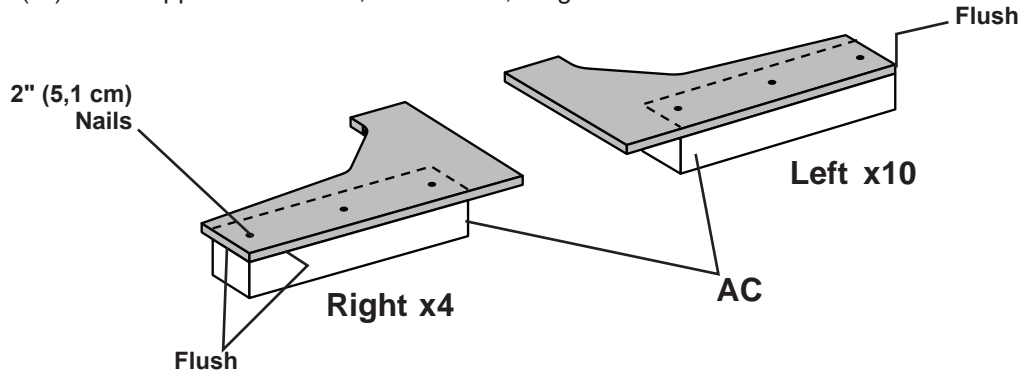



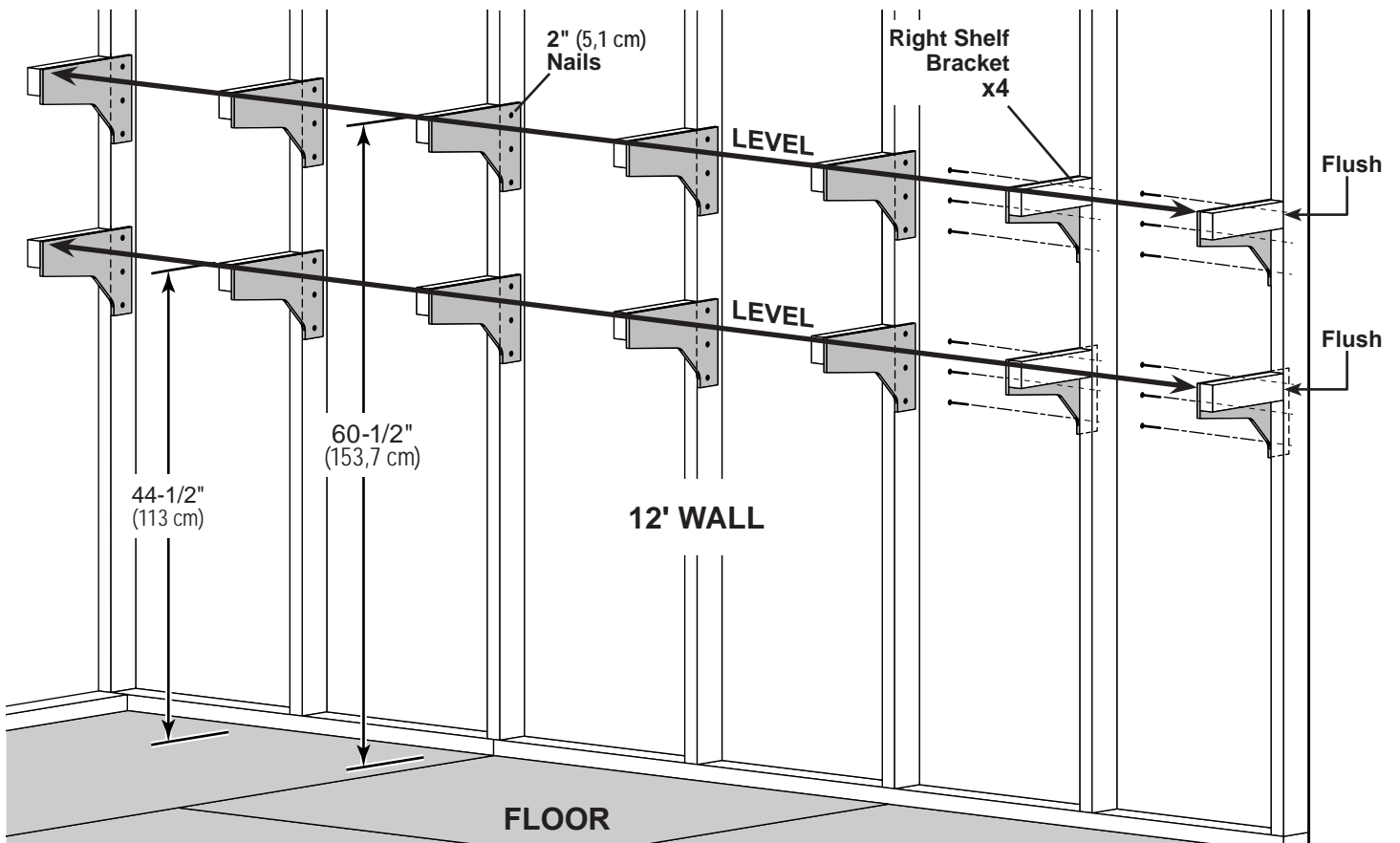

- Install shelf supports at shown heights from floor and flush to wall studs of wall opposite door.  
 Secure with (3) 2" nails.

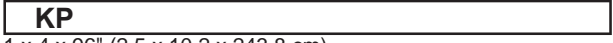
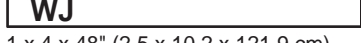
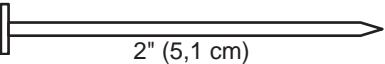

# SHELF INSTALLATION

## PARTS REQUIRED:

<p>x2 </p> <p>7/16 x 11-7/8 x 96" OSB (1,1 x 30,2 x 243,8 cm)</p> <p>x2 </p> <p>7/16 x 11-7/8 x 48" (1,1 x 30,2 x 121,9 cm)</p>	<p>x2 </p> <p><b>KP</b> 1 x 4 x 96" (2,5 x 10,2 x 243,8 cm)</p> <p>x2 </p> <p><b>WJ</b> 1 x 4 x 48" (2,5 x 10,2 x 121,9 cm)</p>	<p>x64 </p> <p>2" (5,1 cm)</p>	
---	--	---	---

- 3** Install shelf panels centered over shelf supports, flush to wall studs and flush at seams.  
Secure with (2) 2" nails in each shelf support. Use (4) nails at seams.

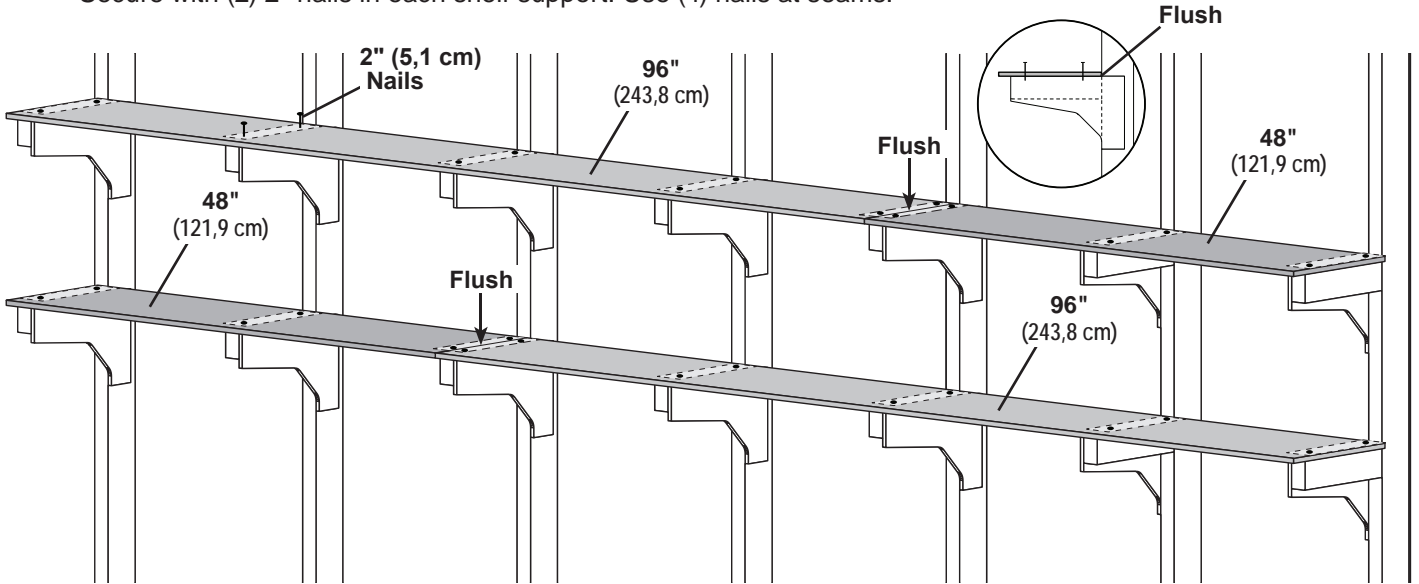

- 4** Install fascia **WJ** and **KP** flush to bottom of shelf panels and flush at seams.  
Secure with (2) 2" nails at each support and (4) 2" nails at seams.

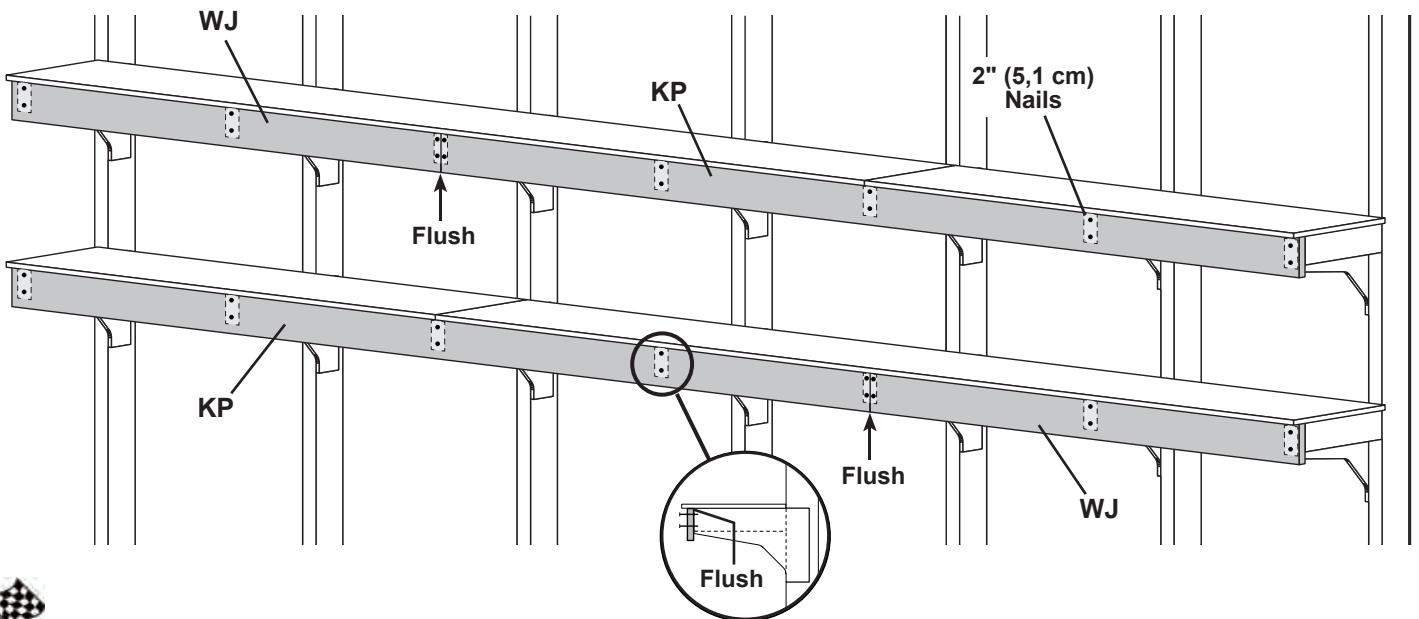

Your shelves are now installed.

# DOORS

## PARTS REQUIRED:

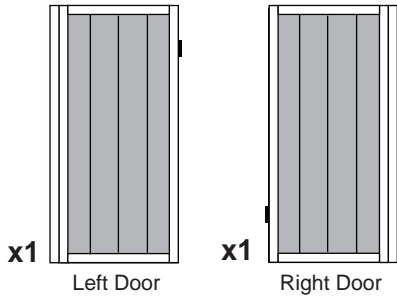

x1 **GAA**  
1 x 3 x 5" (2,5 x 7,6 x 12,7 cm)

x1 **OO**  
69" (175,3 cm) Door Stiffener

x4 3" (7,6 cm)

x2 1-1/4" (3,2 cm)

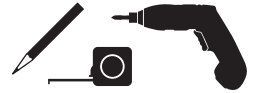

### ✓ BEGIN

- 1 Place doors on flat surface. **3/8" offset is to top.**  
Look for red (right) and green (left) on hinge board.

Attach temporary supports **OO** and **GAA** as shown.

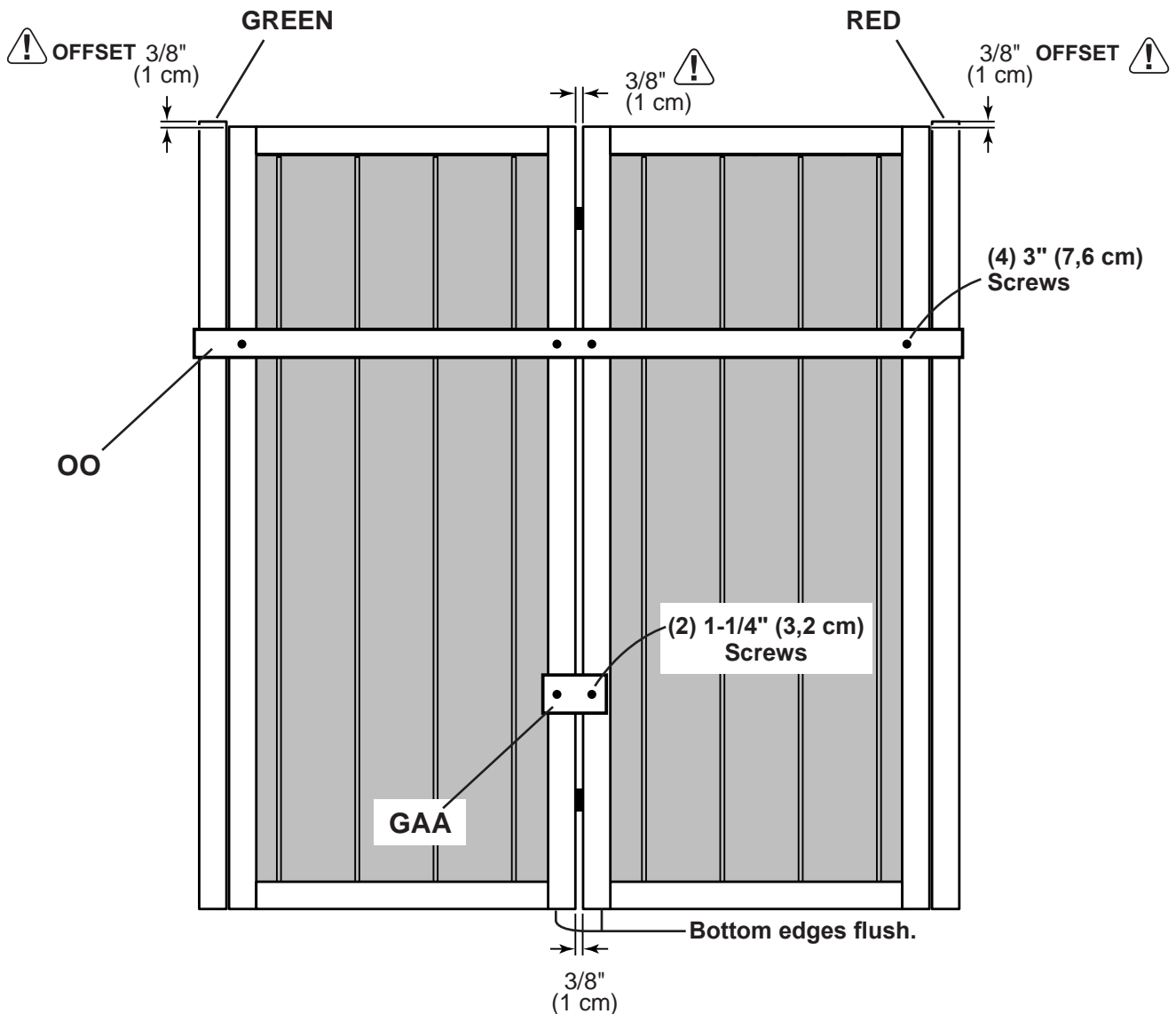

# DOORS

## PARTS REQUIRED:

x1 **OO** *TEMPORARY SUPPORT*  
69" (175,3 cm) Door Stiffener

x12  3" (7,6 cm)

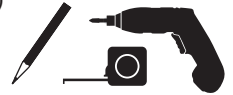

- 2 Install **OO** flush under panels.  
Secure to floor frame with (2) 3" screws (**Fig. A**).  
Mark center of door opening.

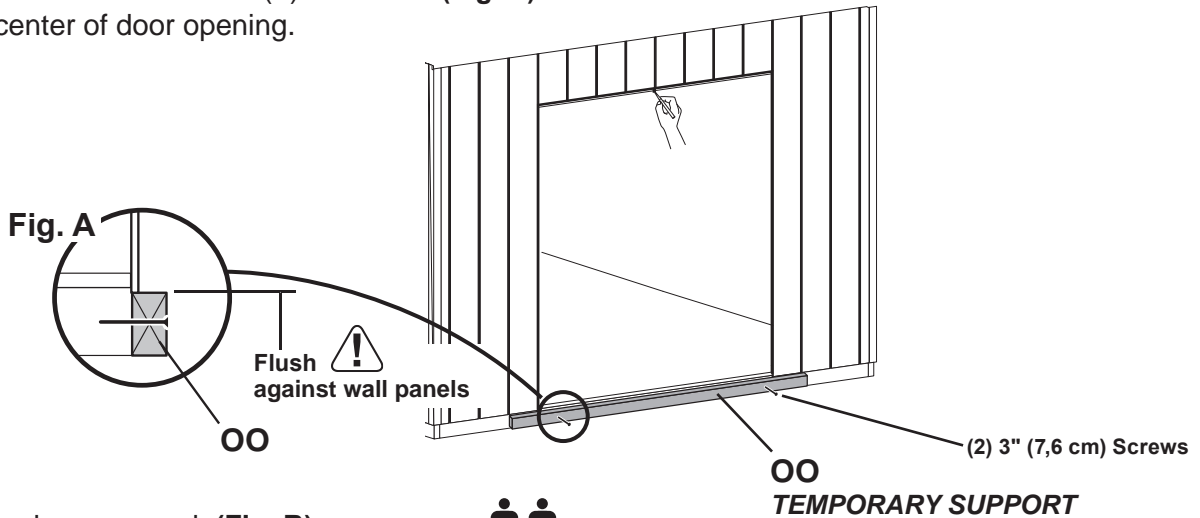

- 3 Center doors on mark (**Fig. B**). 

- 4 Screw hinge boards into wall supports with (10) 3" screws, as shown.  
 **Make sure screws go into framing.**

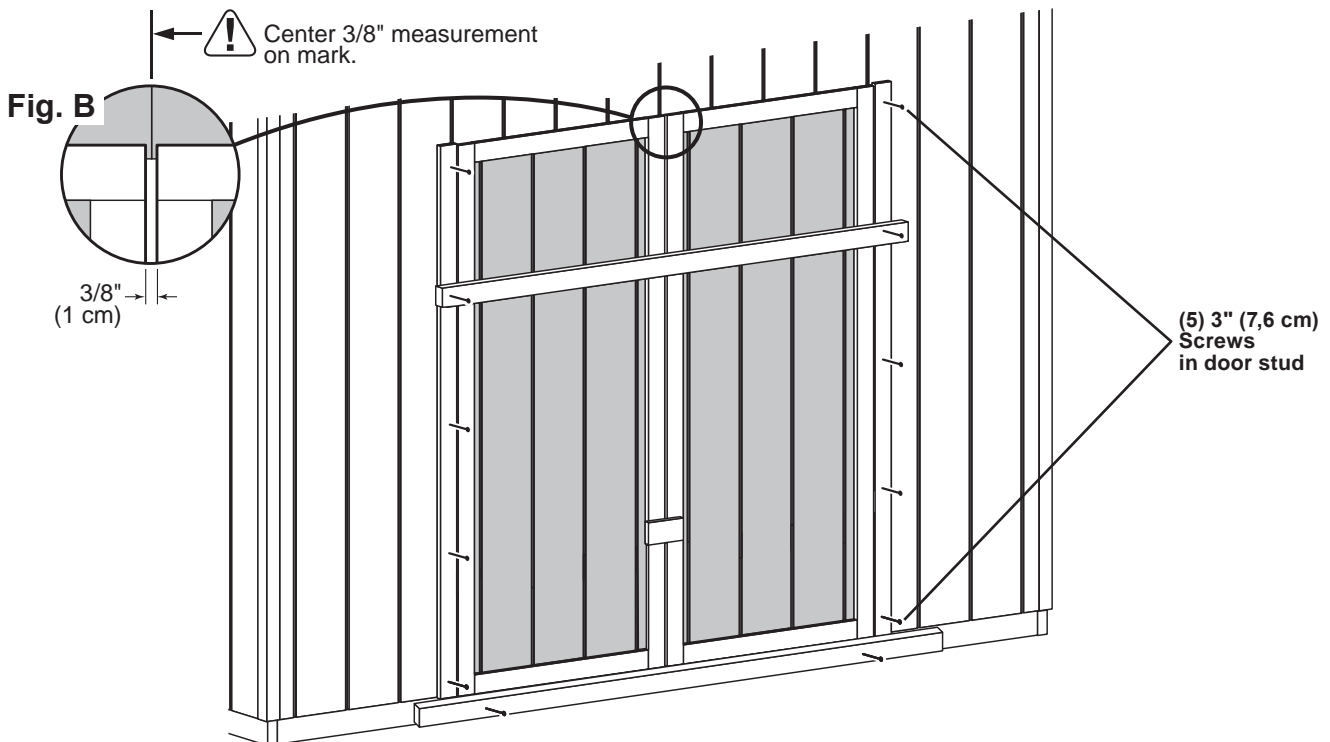

Remove temporary supports and check to make sure doors open and close properly.



Your doors are now installed.

# DOOR STIFFENERS

## PARTS REQUIRED:

x2  **OO**  
69" (175,3 cm) Door Stiffener

x14  2" (5,1 cm)



### ✓ BEGIN

- 1** Center **OO** vertically on the left door in the doorway (**Fig. A**) overlapping 1" (2,5 cm) along the edge of door (**Fig. B**).  
Secure with (7) 2" screws through outside trim into **OO**.
- 2** Center **OO** vertically on the right door in the door opening offset 1" (2,5 cm) from the edge of door (**Fig. B**).  
Secure with (7) 2" screws through outside trim into **OO**.

**Fig. A**

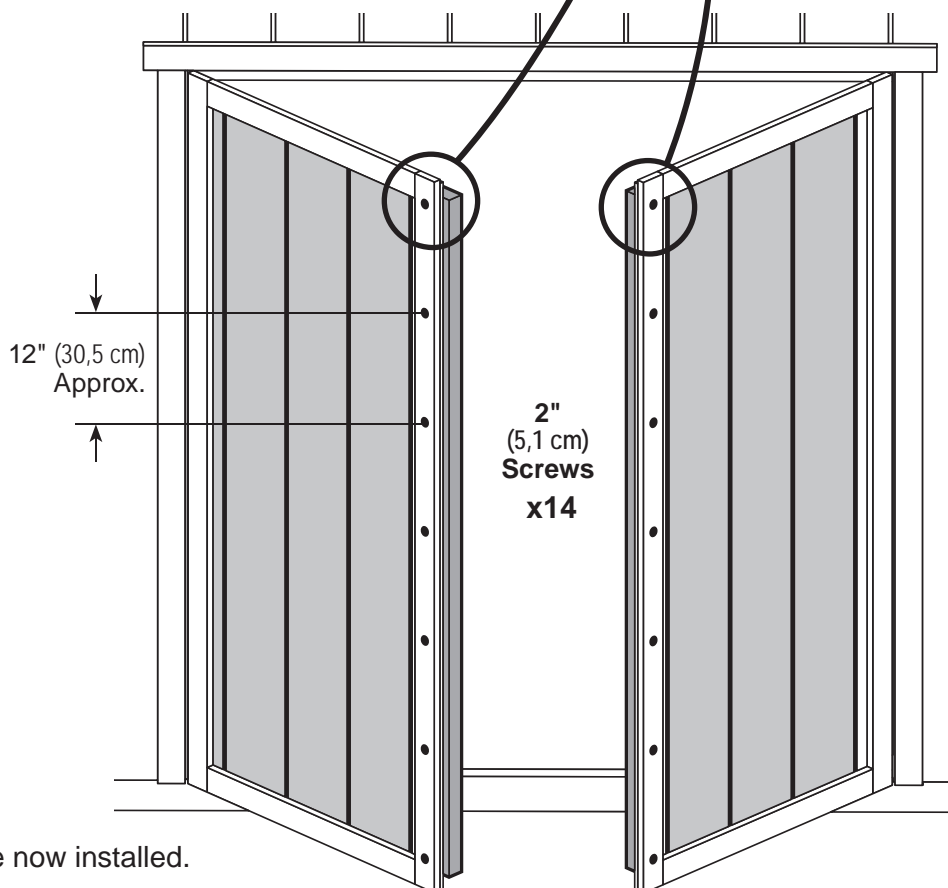
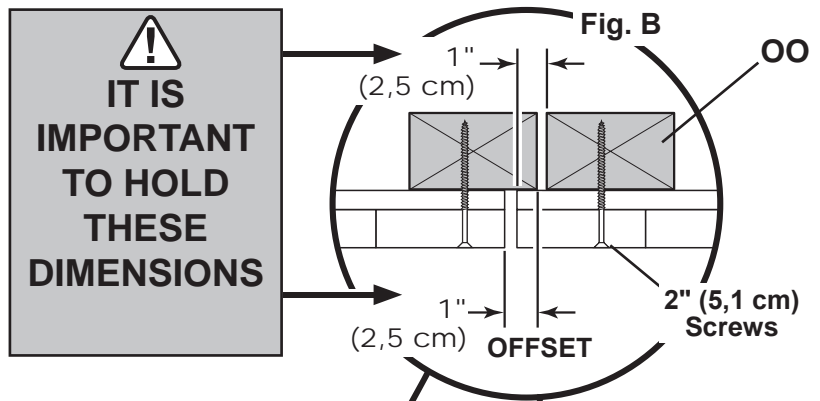
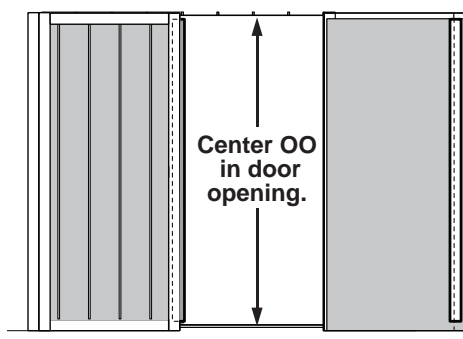

Your door stiffeners are now installed.

# DOORS

## PARTS REQUIRED:

x2 **AH**  
19/32" x 2-1/2" x 26 5/8" (1,5 x 6,3 x 67,6 cm)

x1 **AHR**  
19/32" x 2-1/2" x 62" (1,5 x 6,3 x 157,5 cm)

x1 **AHL**  
19/32" x 2-1/2" x 62" (1,5 x 6,3 x 157,5 cm)

x7   
2" (5,1 cm)

x1   
64" Metal Threshold

x11   
3/4" (1,9 cm)  
Bagged separately/  
special coating

x62   
3/4" (1,9 cm)

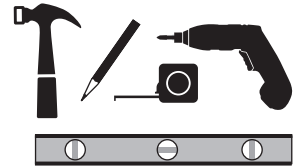

### ✓ BEGIN

- 1 Install trim **AH**, **AHL** and **AHR** as shown. Level **AH** before installing. Fasten trim to each door from inside with (11) 3/4" screws (**Fig. A**, **Fig B**).
- 2 Center trim **ZJ** over doors and secure with (7) 2" finishing nails into framing as shown.

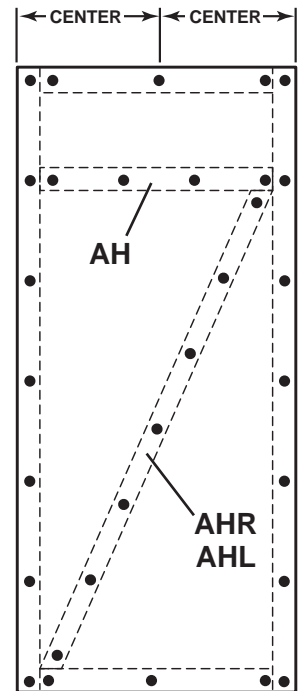
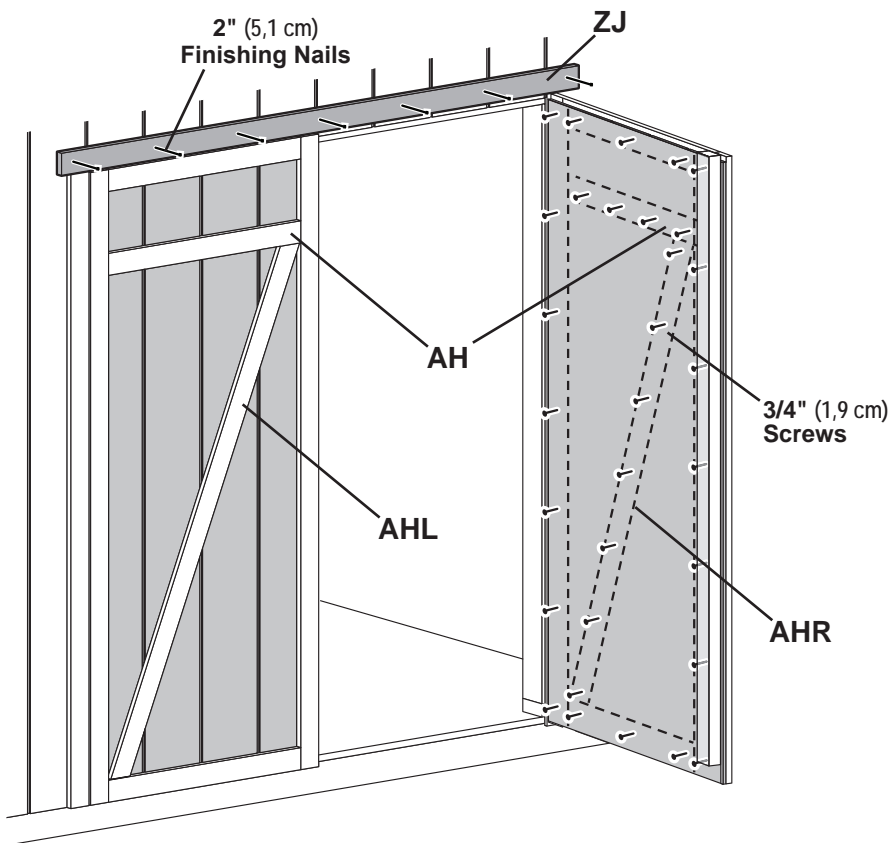
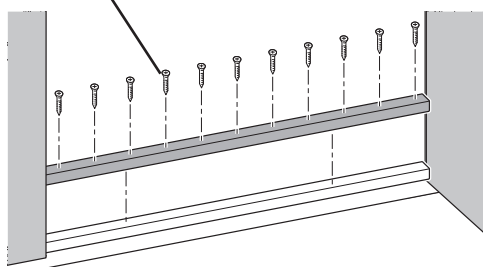

Fig. B

- 3 Install 64" metal threshold with (11) 3/4" screws.

(11) Special Coating Screws



Your door trim and metal threshold are now installed.

## DOOR HARDWARE

### PARTS REQUIRED:

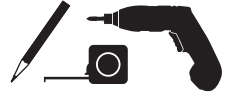

✓ **BEGIN**

**1** Install decorative hinges in locations shown. Secure with 3/4" screws.

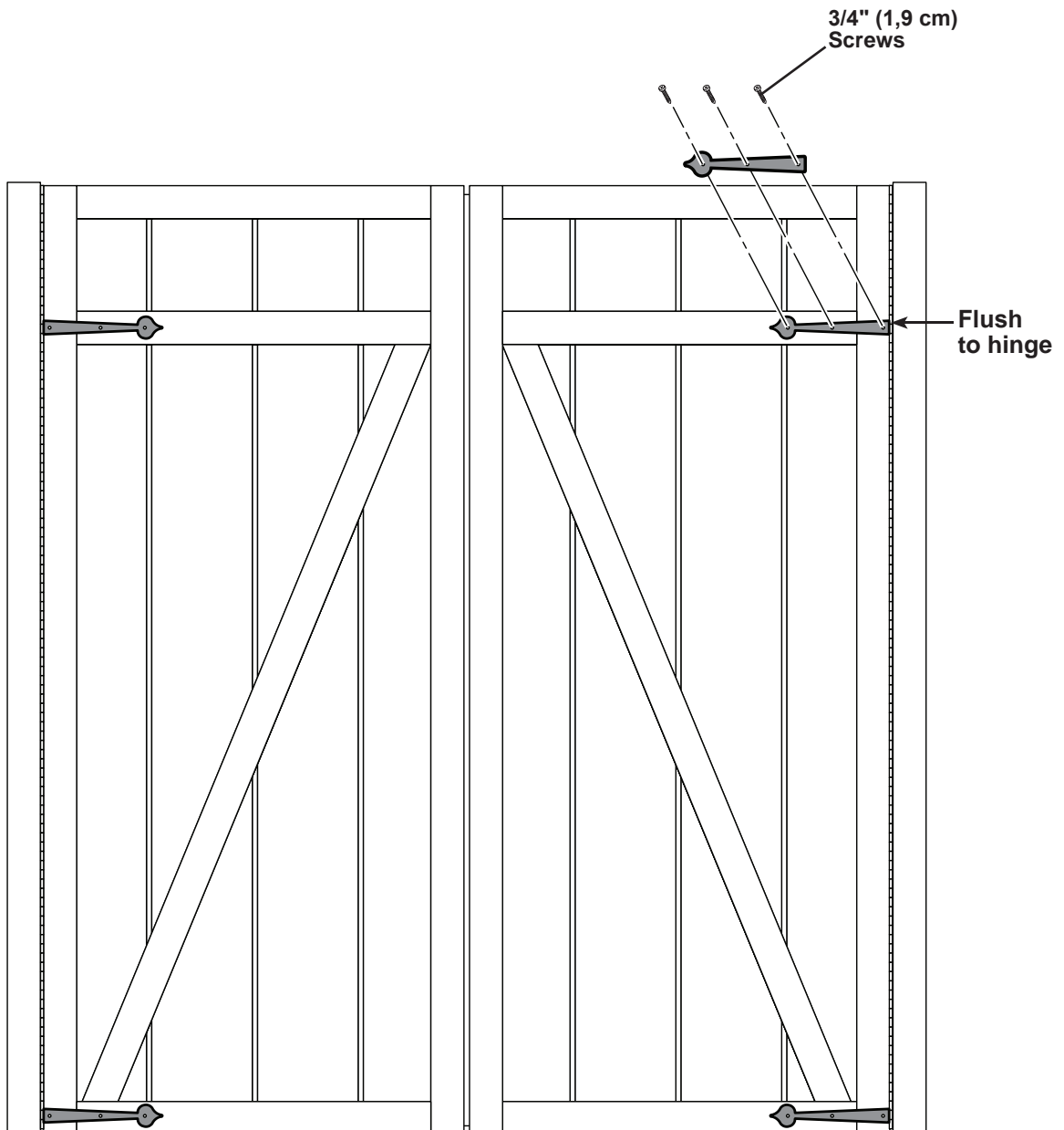

Your decorative door hinges are now installed.

# DOOR HARDWARE

## PARTS REQUIRED:

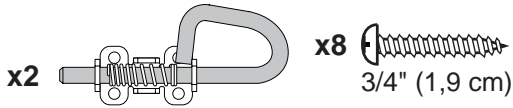

✓ **BEGIN**

- 1** Place bolt on **OO** in open position with bolt end  $\frac{3}{8}$ " (9,5 mm) down from frame. Bolt is open when loop is contacting base (**Fig A**).
- 2** Mark and pre-drill holes for screws. Install bolt with screws supplied.  
Drill  $\frac{5}{16}$ " (7,9 mm) hole deep enough for bolt to slide into.
- 3** Place bolt on **OO** in open position with bolt end  $\frac{1}{2}$ " (12,7 mm) up from floor. Bolt is open when loop is connecting base (**Fig. B**).
- 4** Mark and pre-drill holes for screws. Install bolt with screws supplied.  
Drill  $\frac{5}{16}$ " (7,9 mm) hole deep enough for bolt to slide into.

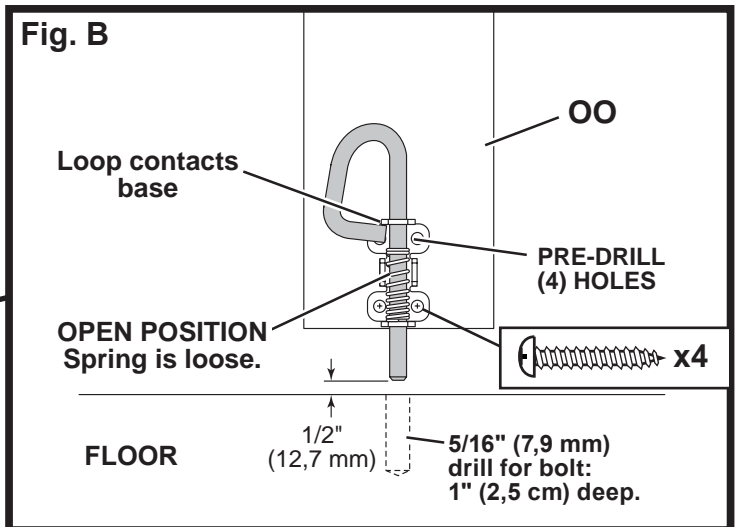
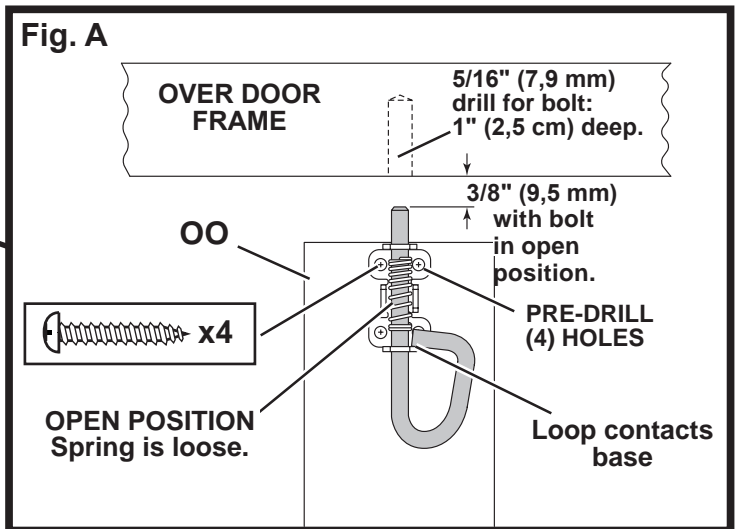
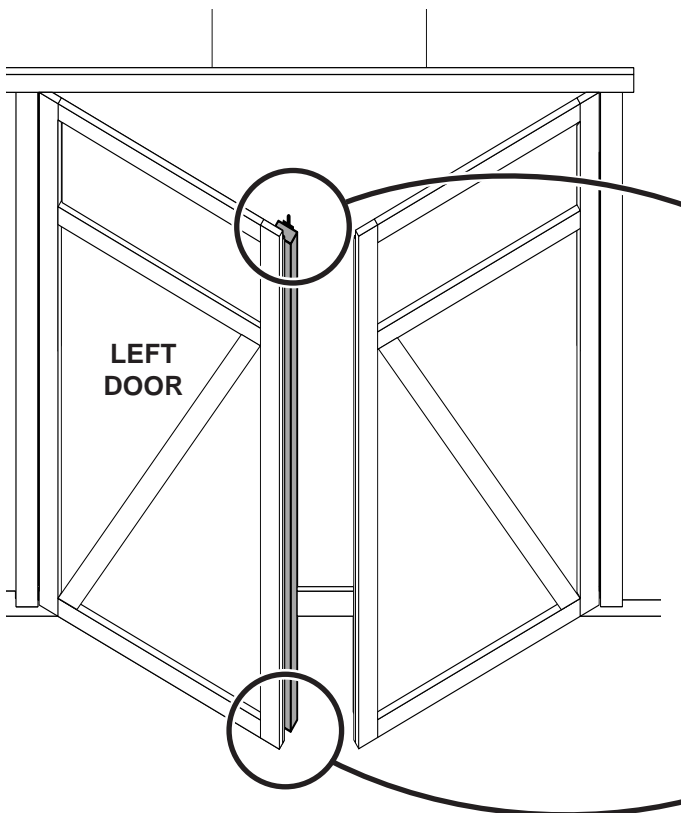

# DOOR HARDWARE

## PARTS REQUIRED:

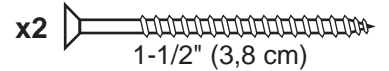
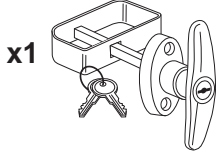

3/8" (10,9 cm) Drill Bit

1/4" (0,6 cm) Drill Bit



- 5** Measure and mark location of hole on outside of right door as shown (Fig. A).  
Pre-drill hole with 1/4" drill.

Re-drill hole with 3/8" drill.



Keep drilled hole square to trim to avoid breaking edge of door stiffener.

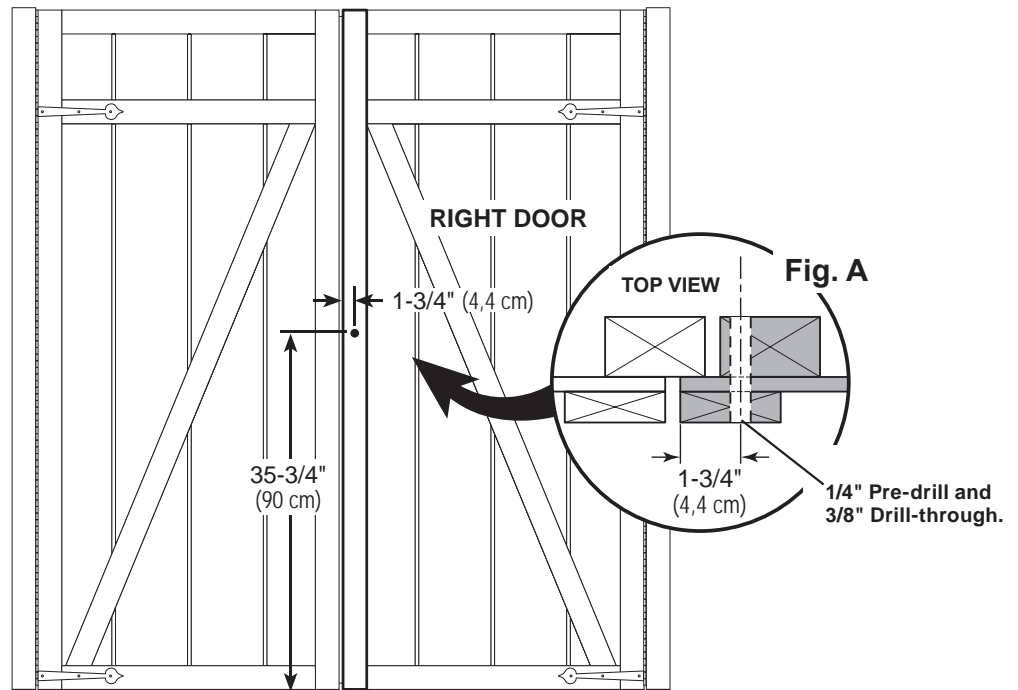

- 6** Insert handle in hole and secure with 1-1/4" screws.

Attach inside handle and secure with set screw as shown.

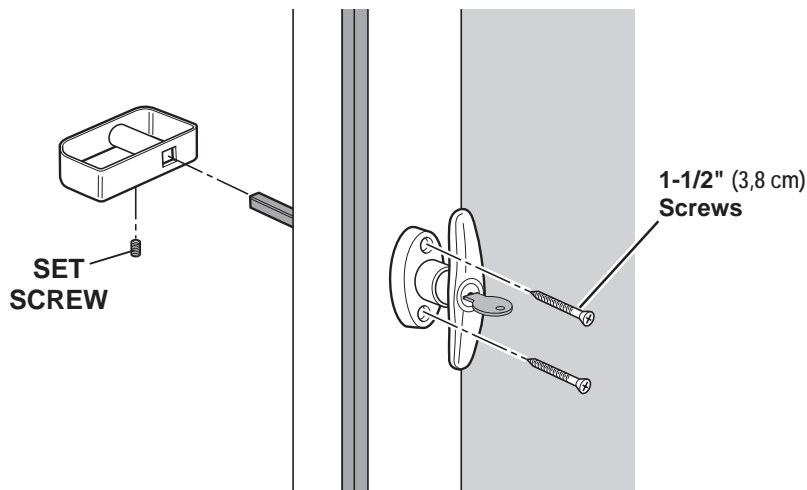

Your spring bolt, T-handle and decorative hinges are now installed.

## HOOK & EYE

### PARTS REQUIRED:

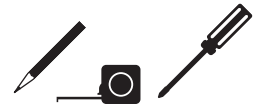
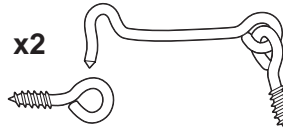

✓ **BEGIN**

**1** Install hooks in wall and into framing behind (**Fig.A**).

**2** Swing door open to locate eye.

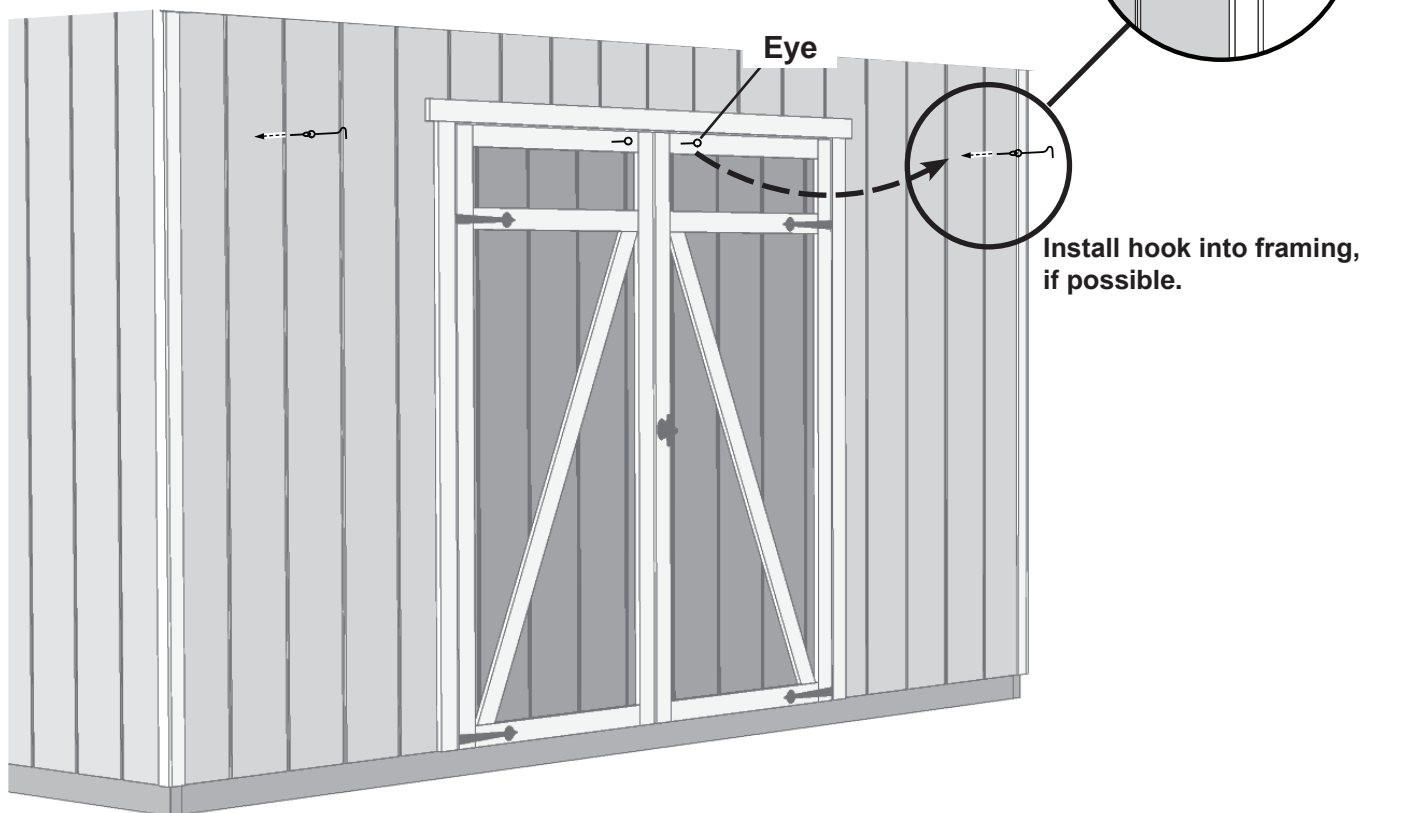

You have installed your hook & eyes.

# GABLE WINDOW

## PARTS REQUIRED:

x2 **DI**  
19/32" x 2-1/2" x 12" (1,5 x 6,3 x 30,5 cm)

x2 **EU**  
19/32" x 2-1/2" x 17" (1,6 x 7,6 x 43,2 cm)

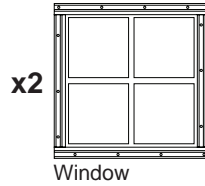

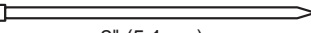
x14  2" (5,1 cm)

x12  3/4" (1,9 cm)



### ✓ BEGIN

- Center window in front gable as shown and secure with 3/4" screws  
Seal back of window with high-quality paintable exterior caulk before installing.

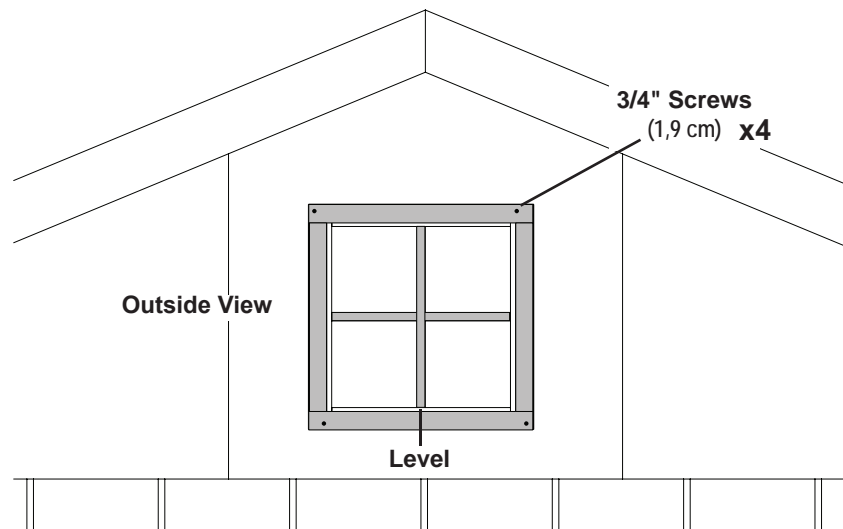

- Install window trim centered over installed window.  
Secure with 3/4" screws and 2" finishing nails, as shown.  
Do not screw into frame of window.  
Snip off protruding nails from inside.

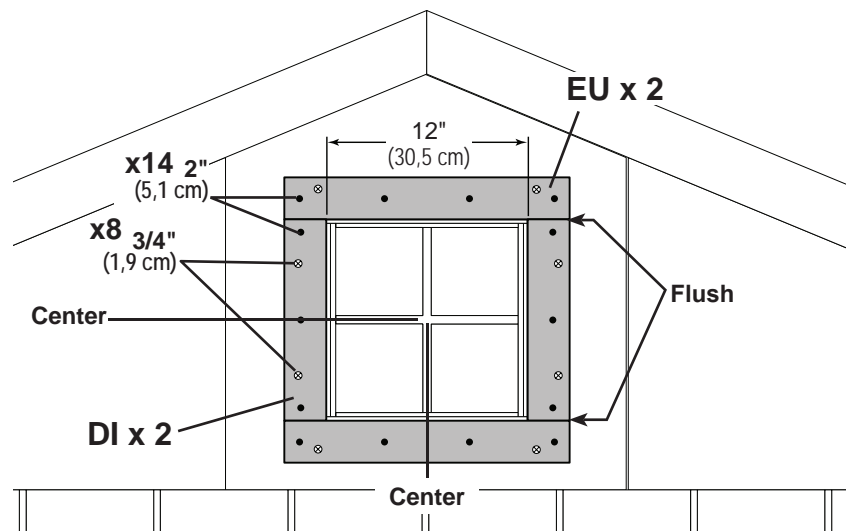

Your gable window and trim is now installed.

## VENT (Not included in kit.)

• Follow directions provided by manufacturer and these instructions.

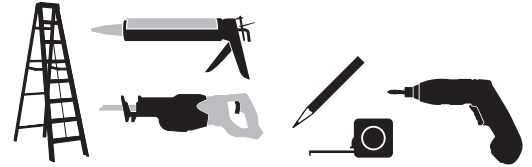
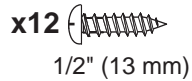
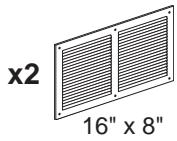

### ✓ BEGIN

- 1 Locate and mark for two vents in side walls as shown; (1) at top and (1) at bottom.

Cut out marked openings.

Caulk behind vent flanges.

Secure with 1/2" screws.

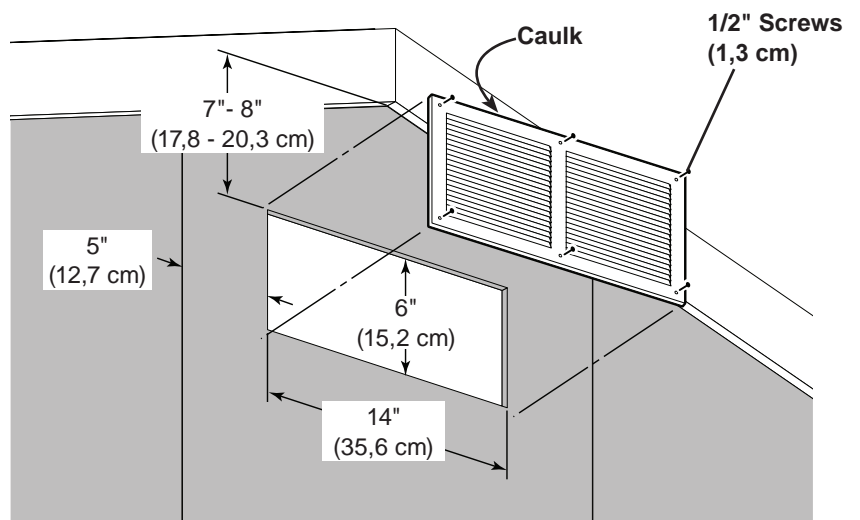
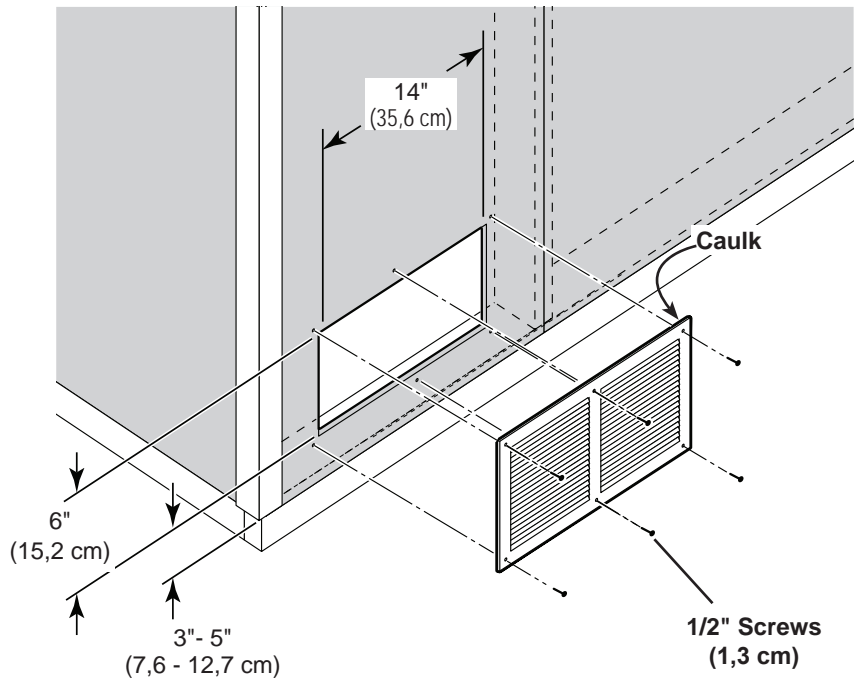

Your vents are now installed.

## PAINT & CAULK

- NOT INCLUDED -



- Use acrylic latex caulk that is paintable. Caulk at all horizontal and vertical seams, between the trim and walls, and all around the door trim.
- Use a high quality exterior acrylic latex paint. When painting your building, there are a few key areas that can be easily overlooked that must be painted:
  - Bottom edge of all siding and trim
  - Inside of doors and all 4 edges

### Note:

Prime all un-primed exterior wood before painting.  
(Follow directions provided by manufacturer.)

## ROOF FELT

- NOT INCLUDED -

- Install felt flush to all roof edges overlapping 3". Use minimal amount of roofing nails to hold in place.

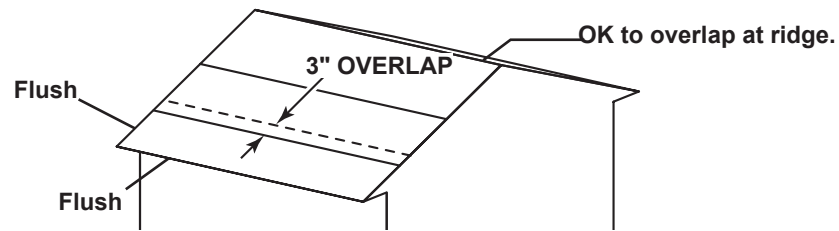

## DRIP EDGE

- NOT INCLUDED -

- Install drip edge over roof felt on gable side and under roof felt on eave side (Fig. A).
- Do not use nails on side of drip edge that hangs over side of building.
- Only nail top of drip edge as shown.

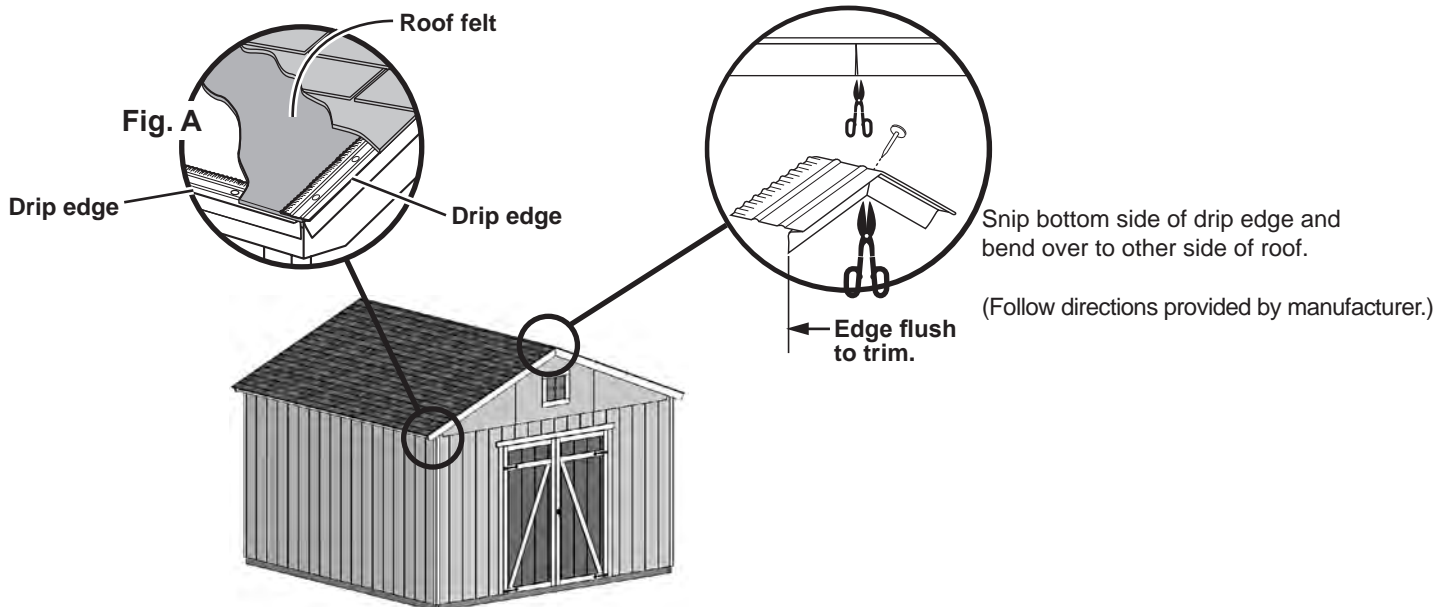

NOTE: 12' x 12' Model Shown.

# SHINGLES

- NOT INCLUDED -

- Follow directions provided by manufacturer and these instructions.

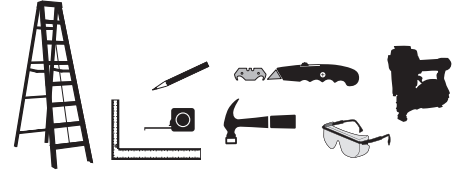

**!** Familiarize yourself with a 3-Tab Shingle.

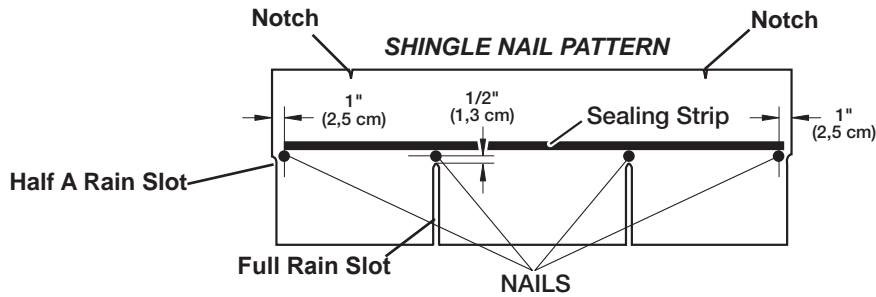

**!** NEVER DRIVE FASTENERS INTO OR ABOVE SEALING STRIPS.

**✓** BEGIN

- 1 Install first starter row upside down and color up with a 1" overhang at back and bottom of roof panel. Use (4) nails per shingle. Starter row must be straight and level all the way across with lower edge of roof deck.  
NOTE: If you have installed drip edge install shingles flush to drip edge.

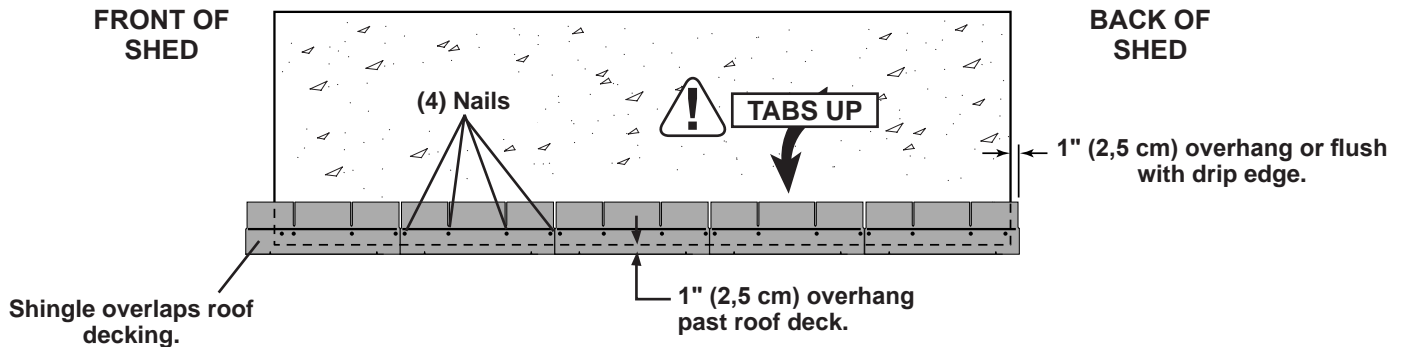

# SHINGLES

continued...

- 2 Beginning at front of shed, install first row of shingles with notch at 1" past roof edge or flush with drip edge.

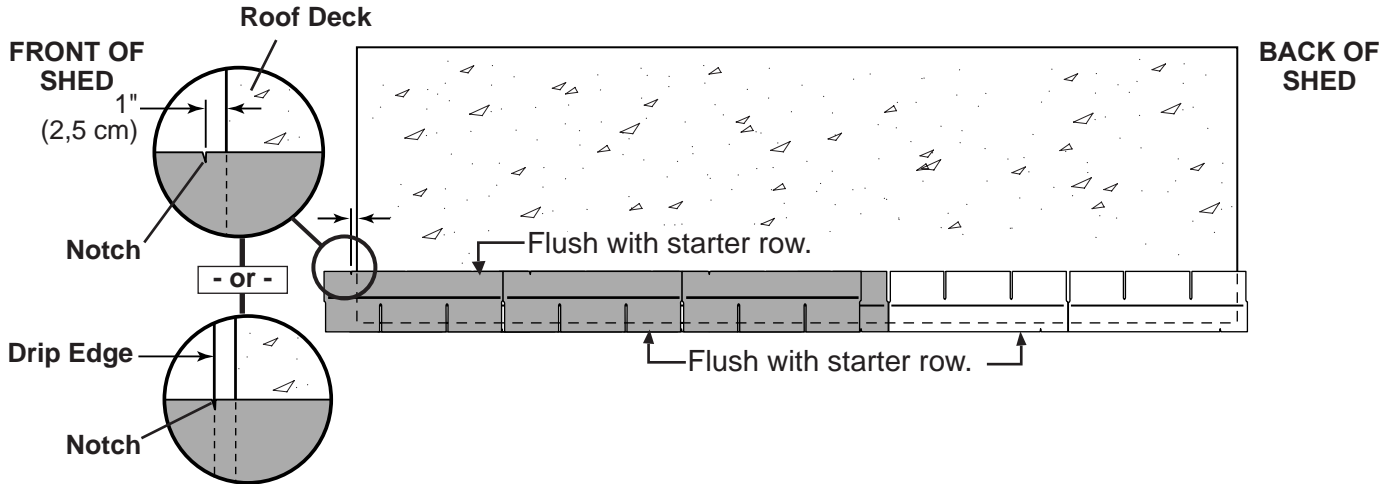

- 3 Install second row of shingles flush at top of first row's rain slots. Ensure 1" overhang or flush to drip edge at front, stagger each row.

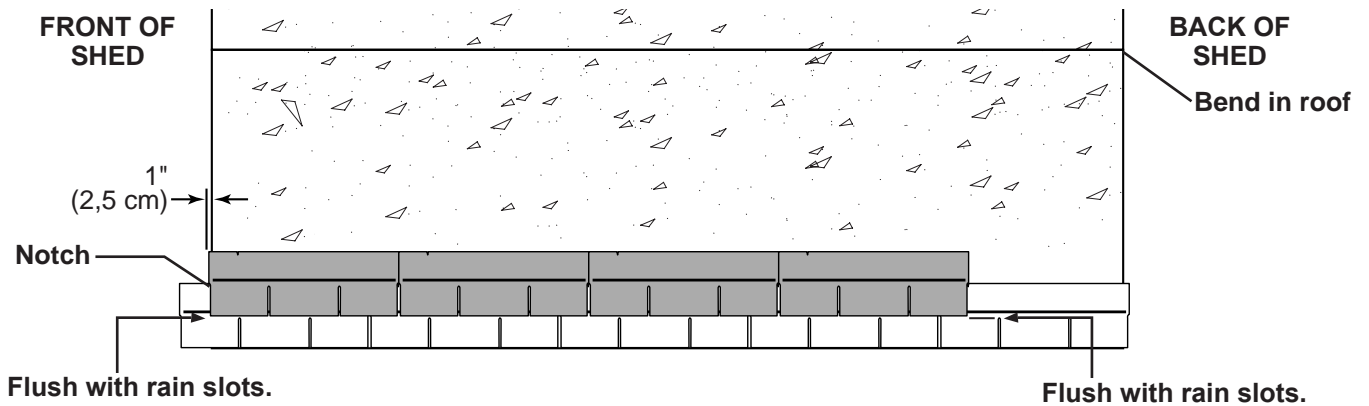

- 4 Continue installing rows of shingles by staggering at front.

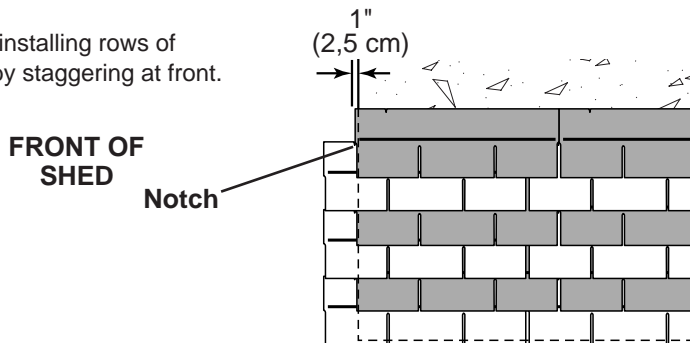

# SHINGLES

continued...

- 5 Continue installing rows of shingles to the peak. At the peak make sure there is a maximum of 5" or less to the rain slot, as shown below. If shingles overlap at ridge cut to peak with a utility knife.

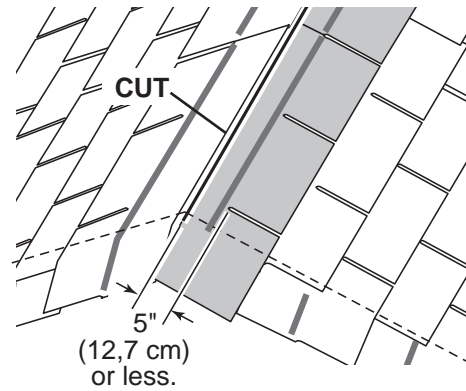
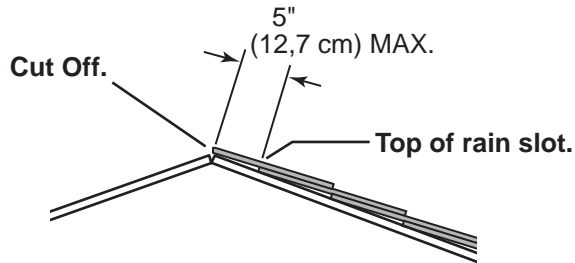

- ! • If more than 5" to rain slot you must install another row of shingles.

- 6 Repeat steps 1 - 7 to shingle the opposite side of your roof. Trim shingles at ridge.

- 7 Once both sides are shingled you need to trim ends. Strike a chalk line 1" from edge.

- 8 Using your shingle hooked blade carefully cut shingles along chalk line.

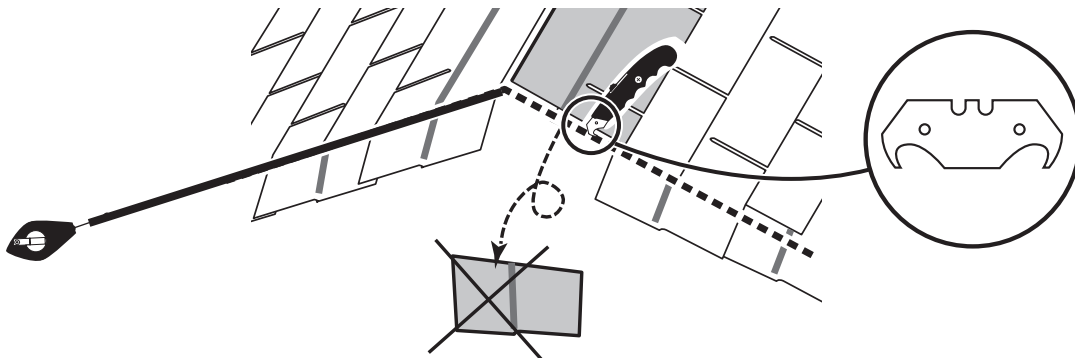

You have finished shingling your roof. Proceed to capping the ridge.

# SHINGLES - RIDGE CAP

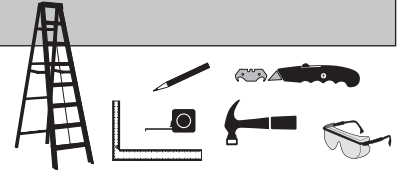

• You will finish off the top of the roof with a ridge cap made from shingles.

## ✓ BEGIN

1 Cut shingles in THREE pieces. Hint: Use cut-off pieces first.

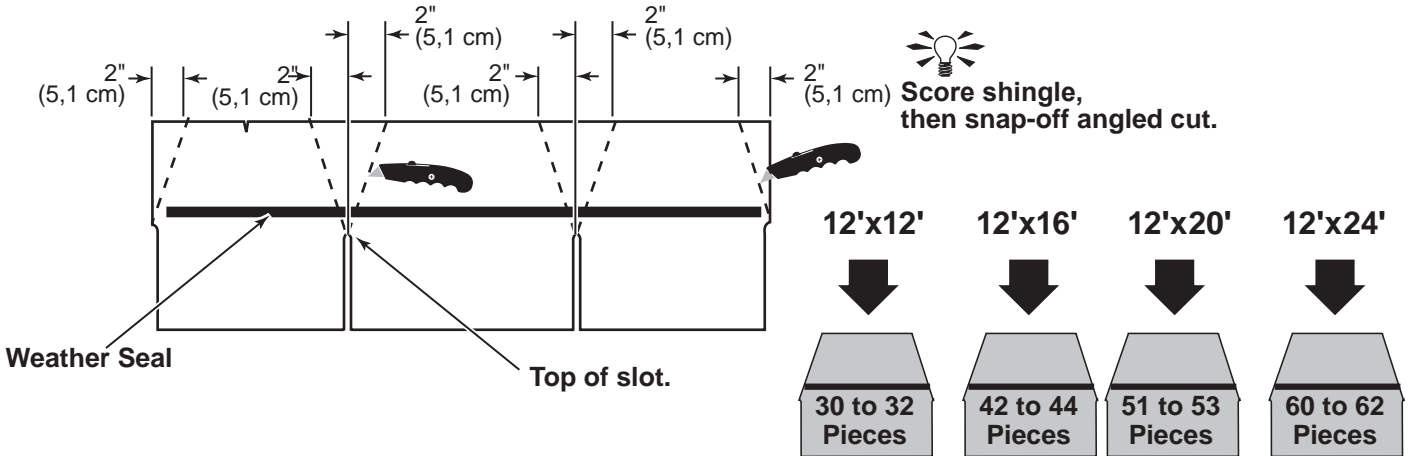

2 Install first ridge cap flush to shingles at front, as shown.

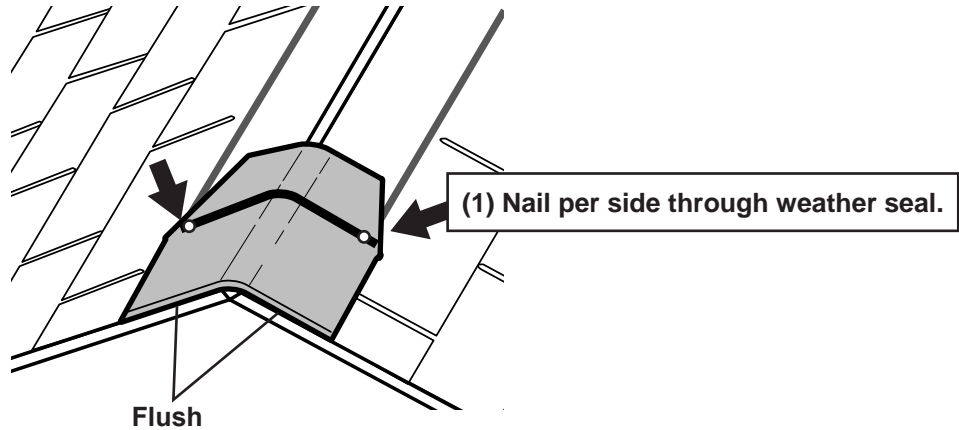

3 Install second ridge cap 5" back, as shown.

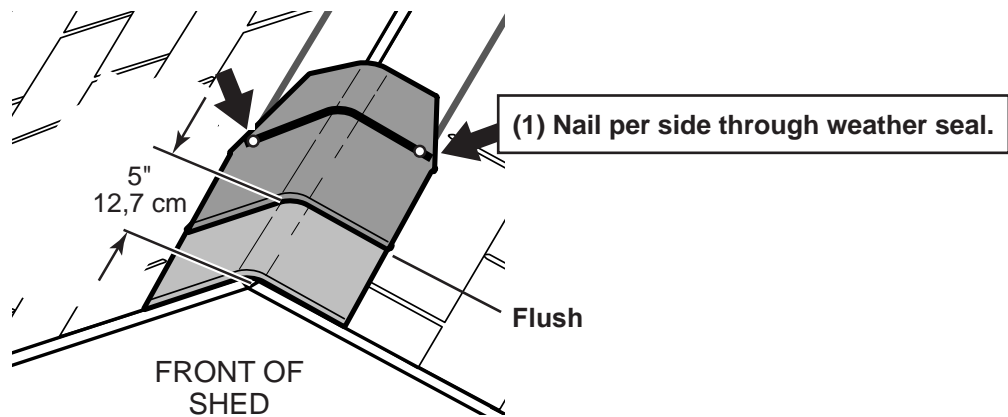

# SHINGLES - RIDGE CAP

continued...

- 4 Continue installing ridge cap to back of roof.

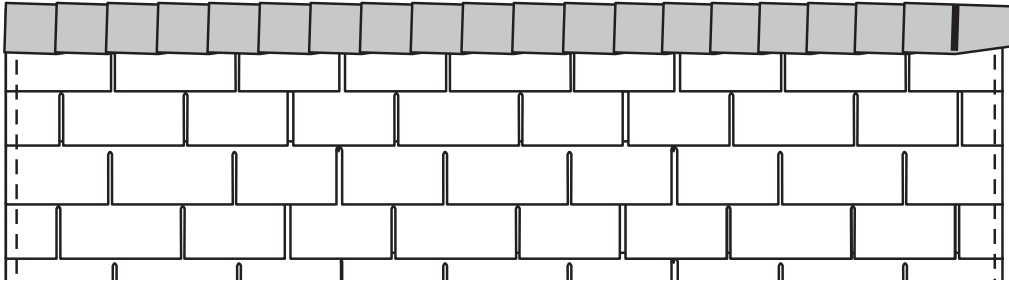

- 5 Make sure there is 4" between the shingle-color and edge of shingles.

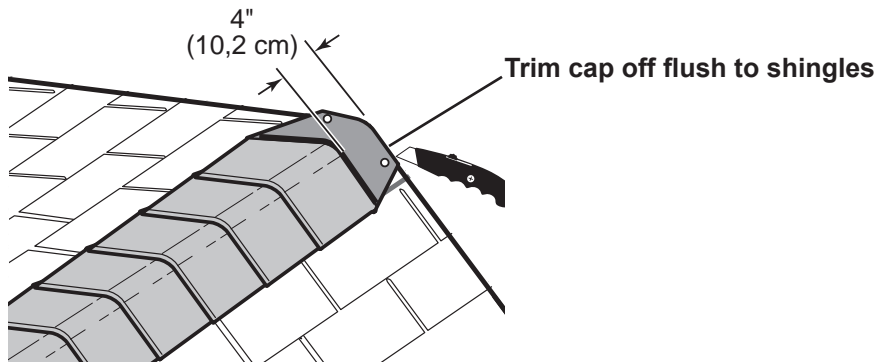

- 6 When you have 4" minimum of shingle color cut one piece to cap your roof.

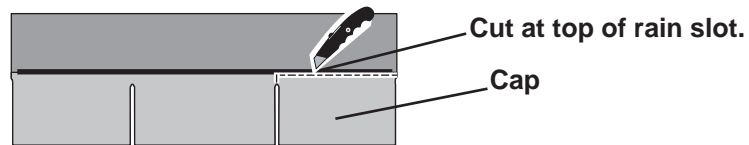

- 7 Install flush to shingles.

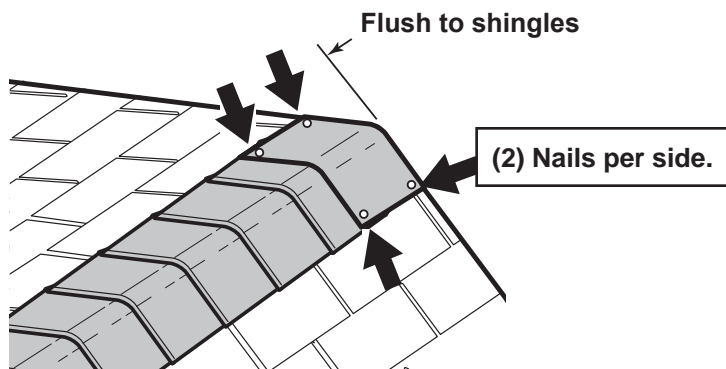

**FINISH**

You have finished your ridge cap.

# 16917 12' x12' Order Form

CATEGORY	PART DESCRIPTION	PART SIZE	PART ITEM #	BUILDING QTY.	PART ID
<b>2 X 3</b>	Loft Ledger Board "A"	LUM SPF 2X3X96 #2&BTR	12115	1	PT
	Loft Ledger Board "B"	2 X 3 X 48" PLATE	Q 48000000000	1	NK
	Shelf Support	2 X 3 X 10" SUPPORT	Q 10000000000	14	AC
<b>2 X 4</b>	Back Wall Top & Btm "A" / Dblr "A" / Loft	LUM SPF 2X4X96 #2&BTR	12306	9	TP
	Side Wall T & B Plate "A" / Dblr "B"	LUM SPF 2X4X92-5/8 #2&BTR	12305	4	TJ
	Side Wall T & B Plate "B"	2 X 4 X 44 3/8" PLATE	O 44060000000	4	HVC
	Side Wall Top Plate	2 X 4 X 68-1/2"	O 68080000000	4	YFA
	Doubler "C"	2X4X48" DOUBLER/ PLATE/ CRATE	O 48000000000	8	SP
	Wall Studs	2 X 4 X 78 1/2"	O 78080000000	23	AI
	Jack Studs	2 X 4 X 68" STUD	O 68000000000	2	UM
	Over Door Crippler	2 X 4 X 7"	O 07000000000	5	AL
	Header	2 X 4 X 67"	O 67000000000	2	AM
	Rafter	2 X 4 X 77-15/16" @ 22.5	O 77152222000	14	ADA
	Front / Rear Gable Connector	2 X 4 X 18 1/8"-22.5" CONNECT	O 18022222000	4	AF
<b>2 X 6</b>	Overhang "A"	LUM WSPF 2X6X96 #1 PREMIUM PET	12416	2	VX
	Overhang "B"	2 X 6 X 49 3/4" OVERHANG	N 49120000000	2	WTC
<b>1 X 3 PINE</b>	Gauge Block	1 X 3 X 5" PINE FILLER	U 05000000000	1	GAA
<b>1 X 4 PINE</b>	Fascia "A"	LUM SPF 1X4X96 SQ EDGE PET	14407	2	KP
	Fascia "B"	1 X 4 X 48 PET	T 48000000000	2	WJ
<b>7/16 OSB</b>	Upper Roof Panel "A"	OSB 7/16" x 4' x 8'	11110	2	---
	Upper Roof Panel "B"	7/16" OSB 47 7/8" X 48" ROOF	C 48004714000	2	---
	Lower Roof Panel "A"	7/16" OSB 36-1/2" X 96" ROOF	C 96003608000	2	---
	Lower Roof Panel "B"	7/16" OSB 36 1/2" X 47-7/8"	C 47143608000	2	---
	Loft Deck "A"	7/16" OSB 23 7/8" X 96" ROOF	C 96002314000	1	---
	Loft Deck "B"	7/16" OSB 23 7/8" X 40 7/8"	C 40142314000	1	---
	Door Header Filler	7/16" OSB 3 1/4" X 66 3/4" HEADER	C 66120304000	1	---
	Shelf Top "A"	7/16" OSB 11 7/8" X 96"	C 96001114000	2	---
	Shelf Top "B"	7/16" OSB 11 7/8" X 48"	C 48001114000	2	---
<b>GUSSETS</b>	Gusset	EZ8"/OSB 6" X 24" GUSSET 22.5"	J 24000600225	12	---
<b>NO GROOVE SIDING</b>	Center Gable Panel w/ Hole ... FRONT	3/8" NG 23 9/16" X 33 1/2" X	K 4800330804W	1	---
	Center Gable Panel ... BACK	3/8" NG 23 9/16" X 33 1/2"	K 48003308044	1	---
	Front / Rear Gable Panel - Right	3/8" NG 23 9/16" X 48" RIGHT FRONT GABLE	K 48002309100	2	---
	Front / Rear Gable Panel - Left	3/8" NG 23 9/16" X 48" LEFT FRONT GABLE	K 48002309200	2	---
	Corner Trim	3/8" NG 1 3/4" X 83-1/2"	K 83080112000	8	---
<b>8OC SIDING</b>	Rearwall Panel "A" / Side Panel	SIDING 8" OC 4'X7'	11506	9	---
	Rear Panel "B"	EZ 8" 23 7/8" X 84" WALL PANEL	J 84002314000	2	---
	Frontwall Panel Right	EZ 8" 48" x 84" RIGHT FRONTWALL	J 84004800101	1	---
	Frontwall Panel Left	EZ 8" 48" x 84" LEFT FRONTWALL	J 84004800201	1	---
	Shelf Bracket	EZ 8" 8" X 12 1/2" PRECUT for	J 120808000PP	14	---
<b>19/32 X 3 SMART TRIM</b>	Vertical / Over Door Trim	19/32 TST 2 1/2" X 72" TRIM	UT72000208000	1	ZJ
	Long Cross Buck - Right	19/32 TST 2 1/2" X 62" 22.5"	UT62000208221	1	AHR
	Long Cross Buck - Left	19/32 TST 2 1/2" X 62" 22.5"	UT62000208222	1	AHL
	Horizontal Door Rail	19/32 TST 2 1/2" X 26 5/8"	UT26100208000	2	AH
	Horizontal Window Trim	19/32 TST 2 1/2" X 17"	UT17000208000	2	EU
	Vertical Window Trim	19/32 TST 2 1/2" X 12"	UT12000208000	2	DI
<b>19/32 X 4 SMART TRIM</b>	Gable Trim Right	19/32 TST 3 1/2" X 84 15/16" 22.5" O/E RGT TRIM	UT84150308221	2	CQR
	Gable Trim Left	19/32 TST 3 1/2" X 84 15/16" 22.5" O/E LFT TRIM	UT84150308222	2	CQL
<b>PURCHASED COMPONENTS</b>	Door Stiffener	LSL 1-1/4 X 2-1/4 X 69 PET	12715	2	OO
	Square Gable Window	WINDOW 12" SQUARE	15273	1	---
	Black T-Handle w/ Faux Hinges	HANDLE - T & "D" HANDLES, FAUX	15220	1	---
	Hardware Kit	H/K CLASSIC SERIES GABLES	15781	1	---
	Threshold	THRESHOLD 7/8" X 1-1/2" X 63-7/8	15420	1	---
<b>PACKAGING</b>	Instructions		16917	1	---
<b>Right Door Assembly</b>	<b>30222-R</b>				
	Door Panel	EZ 8" 31 1/4" X 71 1/2"	J 71083104000	1	---
	Right Hinge Assembly	HINGE RIGHT (RED) 19/32x3 THIN TRIM	30121-TT	1	---
	Vertical Door Stiles	19/32 TST 2 1/2" X 71 5/8"	UT71100208000	2	GY
	Horizontal Door Rails	19/32 TST 2 1/2" X 26 5/8"	UT26100208000	2	AH
<b>Left Door Assembly</b>	<b>30222-L</b>				
	Door Panel	EZ 8" 31 1/4" X 71 1/2"	J 71083104000	1	---
	Left Hinge Assembly	HINGE LEFT (GREEN) 19/32x3 THIN TRIM	30131-TT	1	---
	Vertical Door Stiles	19/32 TST 2 1/2" X 71 5/8"	UT71100208000	2	GY
	Horizontal Door Rails	19/32 TST 2 1/2" X 26 5/8"	UT26100208000	2	AH

### LIMITED CONDITIONAL WARRANTY\*

Backyard Storage Solutions, LLC warrants the following:

1. Every product is warranted from defects in workmanship and manufacturing for 1 year.
2. All accessories, hardware and metal components are warranted for 2 years.
3. All Oriented Strand Board (OSB) is warranted for 2 years
4. Siding and Trim is warranted for 15 years.
5. LP Prostruct® Flooring is warranted for 10 years
6. Cedar lumber is warranted for 15 years.
7. Preserved Pine is warranted for 10 years.
8. Redwood is warranted for 10 years.
9. Metal Roof is warranted for 25 years.

Backyard Storage Solutions, LLC will repair, replace or pay for the affected part. In no event shall Backyard Storage Solutions, LLC pay the cost of labor or installation or any other costs related thereto. All warranties are from date of purchase. If a cash refund is paid on an affected part, it will be prorated from the date of purchase.

### CONDITIONS

The warranty is effective only when:

1. The unit has been erected in accordance with the assembly instructions.
2. The unit has been properly shingled and painted or stained and regularly maintained thereafter.
3. The failure occurs when the unit is owned by the original purchaser.
4. Backyard Storage Solutions, LLC has received the warranty registration card within thirty (30) days of purchase and notification of the failure in writing within the warranty period specified above.
5. Backyard Storage Solutions, LLC has had reasonable opportunity during the sixty (60) days following receipt of notification to inspect and verify the failure prior to commencement of any repair work.

### REQUIREMENTS

#### Storage Buildings

To validate your warranty, it is necessary to properly maintain your Backyard Storage Solutions, LLC unit; shingle the roof and paint or solid-colored stain the siding using quality, 100% acrylic latex exterior product with a minimum of two (2) coats within thirty (30) days of assembly; caulk above all doors and all horizontal and vertical trim boards; paint and seal all exposed edges, sides and faces of siding/trim and OSB siding to include all exterior walls and all sides and all edges of doors.

#### Gazebos & Pergolas

To validate your warranty, it is necessary to properly maintain your Backyard Storage Solutions, LLC unit. This includes treating all of the exposed cedar and pine surfaces on your gazebo or pergola structure with an exterior grade wood preservative, an exterior oil-based semi-transparent stain, an acrylic latex exterior paint or an acrylic latex solid color exterior stain within 30 days of assembly and as needed thereafter to maintain your warranty.

Keep vegetation trimmed away from building and make sure siding panels and trim do not come in contact with masonry or cement. The minimum ground clearance for siding must be one half inch (½ inch) from concrete slab or two and one half inches (2 ½") from the ground when building is erected or constructed on a treated wood floor kit. Water from sprinklers must be kept off unit. In no event will Backyard Storage Solutions, LLC be responsible for any indirect, incidental, consequential or special damages nor for failure(s) that are caused by events, acts or omissions beyond our control including, but not limited to, misuse or improper assembly, improper maintenance (which eventually leads to rot or decay) and acts of God. Backyard Storage Solutions, LLC will not be held responsible for any labor costs incurred to construct your unit.

This warranty gives you certain specific rights that vary from state to state.

### CLAIM PROCEDURE

To make a claim under this warranty, you can either call 1-888-827-9056 or email: [customerservice@backyardproducts.com](mailto:customerservice@backyardproducts.com).

Please have ready the information below when you call or include the information in your email:

1. The model and size of the product.
2. A list of the part(s) for which the claim is made.
3. Proof of purchase of the Backyard Storage Solutions, LLC item, as shown on the original invoice or receipt.
4. Run code: found on exterior product label or assembly instructions enclosed in the product package.

All other inquiries can be mailed to:

Backyard Storage Solutions, LLC  
Attn: Customer Service  
1000 Ternes  
Monroe, MI 48162

**\*WARRANTY TERMS MAY VARY OUTSIDE THE U.S.A.**

**IMPORTANT: This is your warranty certificate.**

15Y PSS BB GEN LDR: 3/20/2019

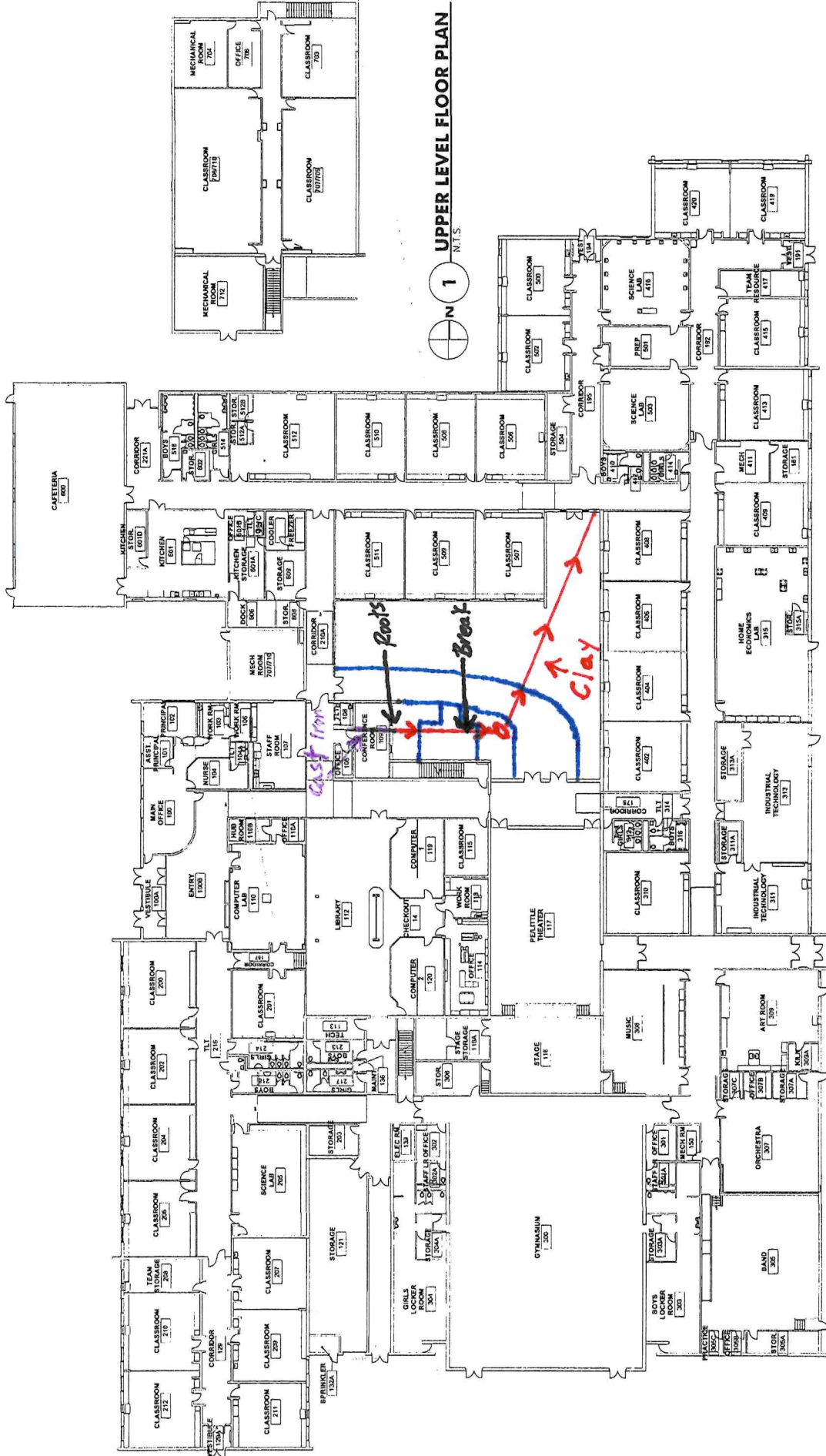

**1** UPPER LEVEL FLOOR PLAN  
N.T.S.

**1** COMPOSITE FIRST FLOOR PLAN - MACARTHUR MIDDLE SCHOOL  
N.T.S.

# Jason Prempas Eagle Project Proposal



**Location:** MacArthur Middle School: 700 North Schoenbeck Rd, Prospect Heights, IL 60070

**Plan:** Transplant plant pots to tray, dig holes for plants, plant the plants (roughly 2-3 thousand)

**Workdays:** Friday 22<sup>nd</sup> of September the MacArthur Middle School students will working on the prairie after school as I lead.(Anyone else is welcome to come) Saturday or Sunday the 23rd or 24th the Boy scouts along with the PHNRC normal volunteer group will be helping us complete the project.

**Benefactor:** The MacArthur Middle School will be the benefactor of this project. While the PHNRC will be supplying most of the materials.

## Supplies:

1. Gloves (people should bring their own)
2. The PHNRC will be supplying a substantial: augers, trowels, tables, gloves, chairs, and all of the plants.