

Board of Education Regular Meeting
Monday, March 15, 2021 7:30 PM
Shelby-Rising City School Room 402
650 N. Walnut
Shelby, NE 68662-0218

1. Call to Order
2. Pledge of Allegiance
3. Announce Open Meeting Act Posting and Location
4. Recitation of the District Mission Statement: The Mission of the Shelby/Rising City Public Schools is to provide a quality education through Innovation, Integrity, Accountability and Service.
5. Recognition of Visitors
During this time visitors may request to the board the opportunity to speak at the appropriate time. The Board then allow for Public Comments. Each speaker will be limited to 5 minutes and all of the Public Comment time will be limited to 30 minutes. An exception will be made for those speakers appearing on the Agenda as presenters.
 - 5.1. Mrs. Hernbloom and her students will present information about Quiz Bowl to the Board. Mr. Riggs will present on Mystery Science.
6. Approval of Agenda
7. Consent Agenda
 - 7.1. Minutes
 - 7.2. Treasurers Report
8. Administrative Reports
 - 8.1. Athletic Director/Activities Director Report
 - 8.2. Elementary Principals Report
 - 8.3. Secondary Principals Report
 - 8.4. Superintendents Report

9. District Reports

9.1. Technology Report

9.2. Maintenance/Facilities/Transportation Report

9.3. Board/Committee Report

9.4. The Board will hear from Shannon Vogler who will present the final report on the Cognia External Visit

9.5. The Board will hear a report about the Life Skills and Transition Program set for implementation during the 2021-22 school year

10. Discussion Items

10.1. The Board will participate in a video presented by NASB on the revision of Rule 10 and 14. This will take place at 8:30 PM.

11. Action Items

11.1. The Board will discuss, consider and take all necessary action on a request from two students for mid-term graduation in December, 2021

11.2. The BOE will consider, discuss and take all necessary action on offering a Jump Start summer program prior to the 2021-22 school year.

11.3. The Board will discuss, consider and take all necessary action on the purchase of a replacement milk cooler for the kitchen at the price of \$2525.00

11.4. The Board will discuss, consider and take all necessary action on the purchase of a Scotsman Ice Maker for the salad bar in the kitchen for \$3209.

11.5. The Board will discuss, consider and take all necessary action on designating ESU 7 to provide contracted Level I, II and III Special Education services for the 2021-22 School year.

11.6. The Board will discuss, consider and take all necessary action on offering employment to recommended certificated teachers for the 2021-22 school year.

11.7. The Board will consider, discuss and take all necessary action related to the proposed termination of a certificated employee's contract.

12. Set Dates

13. Adjournment

Board of Education Regular Meeting
Monday, February 15, 2021 7:00 PM Central

Shelby-Rising City School Room 402
650 N. Walnut
Shelby, NE 68662-0218

Kasey Hopwood: Present
Jeff Kuhnel: Present
Geoffrey Ruth: Present
Jackie Sliva: Present
Heath Vrbka: Present
Chris Whitmore: Present

Present: 6.

Called to Order by President Geoff Ruth

1. Call to Order

2. Pledge of Allegiance

3. Announce Open Meeting Act Posting and Location

4. Recitation of the District Mission Statement: The mission of the Shelby/Rising City Public Schools is to provide a quality education through Innovation, Integrity, Accountability and Service

5. Recognition of Visitors

6. Mrs. Hernbloom will introduce members of the National Honor Society to the Board

7. Approval of Agenda

Motion to approve agenda as presented Passed with a motion by Jeff Kuhnel and a second by Heath Vrbka.

Kasey Hopwood: Yea, Jeff Kuhnel: Yea, Geoffrey Ruth: Yea, Jackie Sliva: Yea, Heath Vrbka: Yea, Chris Whitmore: Yea
Yea: 6, Nay: 0

8. Consent Agenda

Motion to approve Consent Agenda Passed with a motion by Chris Whitmore and a second by Kasey Hopwood.

Kasey Hopwood: Yea, Jeff Kuhnel: Yea, Geoffrey Ruth: Yea, Jackie Sliva: Yea, Heath Vrbka: Yea, Chris Whitmore: Yea
Yea: 6, Nay: 0

8.1. Minutes

8.2. Treasurers Report

9. Administrative Reports

9.1. Athletic Director/Activities Director Report

9.2. Elementary Principals Report

9.3. Secondary Principals Report

9.4. Superintendents Report

10. District Reports

10.1. Technology Report

10.2. Maintenance/Facilities/Transportation Report

10.3. Board/Committee Report

11. Discussion Items

12. Action Items

12.1. The Board will discuss, consider and take all necessary action on the 2021-2022 School Calendar

Motion to approve the 2021-2022 School Calendar Passed with a motion by Heath Vrbka and a second by Jackie Sliva.

Kasey Hopwood: Yea, Jeff Kuhnel: Yea, Geoffrey Ruth: Yea, Jackie Sliva: Yea, Heath Vrbka: Yea, Chris Whitmore: Yea

Yea: 6, Nay: 0

12.2. The Board will discuss, consider and take all necessary action on approving the purchase of new laptops for the staff

Motion to approve the purchase of new laptops for the staff Passed with a motion by Jeff Kuhnel and a second by Kasey Hopwood.

Kasey Hopwood: Yea, Jeff Kuhnel: Yea, Geoffrey Ruth: Yea, Jackie Sliva: Yea, Heath Vrbka: Yea, Chris Whitmore: Yea

Yea: 6, Nay: 0

12.3. The Board will consider, discuss and take all necessary action on the replacement of the Lift Bus.

Motion to replace the existing lift bus with a 2020 Collins Gas, Chevy Chassis 27 passenger from Masters Transportation Passed with a motion by Kasey Hopwood and a second by Jeff Kuhnel.

Kasey Hopwood: Yea, Jeff Kuhnel: Yea, Geoffrey Ruth: Yea, Jackie Sliva: Yea, Heath Vrbka: Yea, Chris Whitmore: Yea

Yea: 6, Nay: 0

12.4. The Board will discuss, consider and take all necessary action on the purchase of a snowblower for the district skid loader.

motion to purchase a snowblower for the skid loader Passed with a motion by Heath Vrbka and a second by Kasey Hopwood.

Kasey Hopwood: Yea, Jeff Kuhnel: Yea, Geoffrey Ruth: Yea, Jackie Sliva: Yea, Heath Vrbka: Yea, Chris Whitmore: Yea

Yea: 6, Nay: 0

13. Set Dates

14. Adjournment

Motion to adjourn at 8:09 Passed with a motion by Geoffrey Ruth and a second by Jackie Sliva.

Kasey Hopwood: Yea, Jeff Kuhnel: Yea, Geoffrey Ruth: Yea, Jackie Sliva: Yea, Heath
Vrbka: Yea, Chris Whitmore: Yea
Yea: 6, Nay: 0

Board of Education
Shelby-Rising City Public Schools
Regular Meeting

March 15, 2021

7:30 PM

<u>Check #</u>	<u>Vendor Name</u>	<u>Amount</u>
Checking	1	Fund: 01 GENERAL FUND
38971	AMAZON	3,248.66
38972	APPLE INC.	39,555.00
38973	ARBUCK, ASHLEY	1,531.44
38974	AUGUSTIN, SARAH	1,531.44
38975	BEARD-WARREN HEATING & AIR CONDITIONING	25.00
38976	BILSTEIN, RENEE	1,520.72
38977	BLACK HILLS ENERGY	2,180.66
38978	BLACKBOURN, EMILY	724.32
38979	BOBOLZ, CODY	1,531.44
38980	BUTLER COUNTY CLERK	104.79
38981	CARLEY, MATT	1,531.44
38982	CONNECTING POINT COMPUTER CENT	357.97
38983	CONSTELLATION ENERGY	899.98
38984	CROMER, MELINDA	1,531.44
38985	CUBBYS CORPORATE OFFICE	2,920.58
38986	CULLIGAN OF YORK	143.00
38987	DEMCO	589.85
38988	DIETZE MUSIC HOUSE	593.64
38989	EAKES OFFICE SOLUTIONS	1,303.79
38990	EDUCATIONAL SERVICE UNIT #7	754.97
38991	EDUCATIONAL SERVICE UNIT #7	25,329.36
38992	EGAN SUPPLY CO.	1,628.80
38993	EVANS, BRIAN	1,140.54
38994	FISCHBACH, KASEY	100.00
38995	FLUFF & STUFF, LLC	150.00
38996	GABEL, GRANT	1,531.44
38997	GENERAL FUND-PETTY CASH	333.30
38998	GLOCK, DENISE	1,531.44
38999	GOULD, ZACHARY	2,041.92
39000	HOMETOWN LEASING	736.27

39001 JACKSON SERVICES, INC	395.54
39002 JAKUB, MADISYN	1,520.72
39003 JENSEN, SARA	1,531.44
39004 KSB SCHOOL LAW, PC, LLO	256.00
39005 LINGO	227.68
39006 LUETTELE, DANIELLE	1,531.44
39007 MATHESON TRI-GAS INC.	838.04
39008 MCILNAY & COMPANY	2,712.35
39009 MECHANICAL SALES, INC	660.50
39010 MENARDS	27.39
39011 MID-AMERICAN RESEARCH CHEMICAL	1,145.00
39012 MIDWEST ALARM SERVICES	122.37
39013 MORNER, AUNDREA	543.24
39014 NAPA AUTO AND TRUCK PARTS	119.88
39015 NEBRASKA ASSOCIATION OF SCHOOL BOARDS	280.00
39016 NIENHUESER, KATE	1,140.54
39017 ORKIN PEST CONTROL	91.17
39018 OSANTOWSKI, KEEGAN	200.00
39019 PATTERSON, MALLORY	724.32
39020 PAY FLEX	100.00
39021 PINNACLE BANK	1,255.91
39022 PITNEY BOWES	210.96
39023 POLK CO. RURAL PUBLIC POWER DISTRICT	12,284.26
39024 PRAIRIE CREEK FAMILY MEDICINE	120.00
39025 RASMUSSEN, JOHN	59.50
39026 REALLY GOOD STUFF, LLC	39.04
39027 RIGGS, JON	1,531.44
39028 SCHUETH, BECKY	1,531.44
39029 SEGNER, MORGAN	1,531.44
39030 SHELBY AUTO CLINIC	649.90
39031 SHELBY LUMBER CO.	88.40
39032 SMITH ELECTRIC	390.00

39033 SPARQ DATA SOLUTIONS	4,160.00
39034 STEWART, STACY	1,531.44
39035 STROMSBURG WATER & CONDITIONING INC.	125.00
39036 TILLEY SPRINKLERS & LANDSCAPING, INC	1,530.00
39037 TIRE OUTLET, INC.	177.00
39038 TONNIGES, JORDAN	1,531.44
39039 TOPIL, SUE	543.24
39040 TROFHOLZ, TURNER	92.96
39041 TRUCK CENTER COMPANIES	193.80
39042 UNIVERSITY OF NEBRASKA - KEARNEY	2,000.00
39043 VERIZON WIRELESS	299.00
39044 VILLAGE OF SHELBY	1,131.18
39045 VOSS, LEYTON	140.00
39046 VOSS, SANDY	1,531.44
39047 WETJEN, ALEXIS	315.00
39048 WETJEN, LILLIAN	180.00
39049 WICKHAM, SEAN	1,339.52
39050 WILTON, KRISTEN	1,531.44
39051 WINDSTREAM NEBRASKA INC.	847.09

INVOICES:	\$ 150,162.66
PAYROLL:	\$ 410,274.74
TOTAL:	\$ 560,437.40

Batch Description: MARCH 2021 GENERAL FUND INVOICES Processing Month: 03/2021 Credit Card Vendor ID: End of Fiscal Year Expense Invoices:
Vendor ID: AMAZON AMAZON PO Number: Invoice Number: 31021 Amount: 3,248.66

Description: 1 Check Type: Checking Account ID: Invoice Date: 03/10/2021 Due Date: 03/15/2021 Status: A 1099 Amount: 0.00
Chart of Account Number Detail Description Cost Center ID Detail Amount 1099 Detail Amount Asset/Asset Tag In Full
01 1100 610 001 0140 0 000 HS MATH SUPPLIES N 31.32
01 2220 640 000 0000 0 000 LIBRARY BOOKS N 358.35
01 2590 610 000 0000 0 000 ENVELOPES N 59.96
01 2610 610 000 0000 0 000 ROOF RAKE FOR SNOW REMOVAL N 174.95
01 2620 450 000 0000 0 000 LED LIGHTS FOR BUS BARN N 2,624.08

Vendor ID: APPLECO APPLE INC. Invoice Number: AE29187881 Amount: 39,555.00
Description: Invoice Date: 03/10/2021 Due Date: 03/15/2021 Status: A 1099 Amount: 0.00
Sequence: 1 Check Type: Checking Account ID: Check Number: Check Date:
Chart of Account Number Detail Description Cost Center ID Detail Amount 1099 Detail Amount Asset/Asset Tag In Full
01 6992 734 000 0000 0 000 TEACHER MAC BOOK AIRS N 39,555.00

Vendor ID: ARBUCKASH ARBUCK, ASHLEY Invoice Number: 31021 Amount: 1,531.44
Description: Invoice Date: 03/10/2021 Due Date: 03/15/2021 Status: A 1099 Amount: 0.00
Sequence: 1 Check Type: Checking Account ID: Check Number: Check Date:
Chart of Account Number Detail Description Cost Center ID Detail Amount 1099 Detail Amount Asset/Asset Tag In Full
01 1100 281 002 0000 0 000 HSA - MAR 2021 N 1,531.44

Vendor ID: AUGUSTINSA AUGUSTIN, SARAH Invoice Number: 31021 Amount: 1,531.44
Description: Invoice Date: 03/10/2021 Due Date: 03/15/2021 Status: A 1099 Amount: 0.00
Sequence: 1 Check Type: Checking Account ID: Check Number: Check Date:
Chart of Account Number Detail Description Cost Center ID Detail Amount 1099 Detail Amount Asset/Asset Tag In Full
01 1100 281 002 0000 0 000 HSA - MAR 2021 N 1,531.44

Vendor ID: BEARD BEARD-WARREN HEATING & AIR CONDITIONING PO Number: 072032 Amount: 25.00
Description: Invoice Date: 03/10/2021 Due Date: 03/15/2021 Status: A 1099 Amount: 0.00
Sequence: 1 Check Type: Checking Account ID: Check Number: Check Date:
Chart of Account Number Detail Description Cost Center ID Detail Amount 1099 Detail Amount Asset/Asset Tag In Full
01 2620 430 000 0000 0 000 FLAME SENSOR N 25.00

Vendor ID: BILSTEINRE BILSTEIN, RENEE Invoice Number: 31021 Amount: 1,520.72
Description: Invoice Date: 03/10/2021 Due Date: 03/15/2021 Status: A 1099 Amount: 0.00
Sequence: 1 Check Type: Checking Account ID: Check Number: Check Date:
Chart of Account Number Detail Description Cost Center ID Detail Amount 1099 Detail Amount Asset/Asset Tag In Full
01 1200 281 000 0000 0 000 HSA - MAR 2021 N 1,520.72

Vendor ID: BLACKHILLS BLACK HILLS ENERGY Invoice Number: 31021 Amount: 2,180.66
Description: Invoice Date: 03/10/2021 Due Date: 03/15/2021 Status: A 1099 Amount: 0.00
Sequence: 1 Check Type: Checking Account ID: Check Number: Check Date:
Chart of Account Number Detail Description Cost Center ID Detail Amount 1099 Detail Amount Asset/Asset Tag In Full

Description:		Invoice Date:	Due Date:	Status:	1099 Amount:	0.00
Sequence: 1	Check Type:	Checking Account ID:	Check Number:	Check Date:		
<u>Chart of Account Number</u>	<u>Detail Description</u>	<u>Cost Center ID</u>	<u>Detail Amount</u>	<u>1099 Detail Amount</u>	<u>Asset/Asset Tag</u>	<u>In Full</u>
01 2211 890 000 0000 0 000	STUDENT OF THE MONTH LUNCH		88.88	0.00	N	
01 2610 626 000 0000 0 000	CUSTODIAL FUEL		139.34		N	
01 2710 626 000 0000 0 000	VAN & BUS FUEL		2,415.87		N	
01 2712 626 000 0000 0 000	SPEED VAN & BUS FUEL		276.49		N	
Vendor ID: CULLIGANYO CULLIGAN OF YORK						
Description:		Invoice Date:	Due Date:	Status:	1099 Amount:	0.00
Sequence: 1	Check Type:	Checking Account ID:	Check Number:	Check Date:		
<u>Chart of Account Number</u>	<u>Detail Description</u>	<u>Cost Center ID</u>	<u>Detail Amount</u>	<u>1099 Detail Amount</u>	<u>Asset/Asset Tag</u>	<u>In Full</u>
01 2610 610 000 0000 0 000	WATER & RENTAL		143.00		N	
Vendor ID: DEMCO DEMCO						
Description:		Invoice Date:	Due Date:	Status:	1099 Amount:	0.00
Sequence: 1	Check Type:	Checking Account ID:	Check Number:	Check Date:		
<u>Chart of Account Number</u>	<u>Detail Description</u>	<u>Cost Center ID</u>	<u>Detail Amount</u>	<u>1099 Detail Amount</u>	<u>Asset/Asset Tag</u>	<u>In Full</u>
01 2220 610 000 0000 0 000	LIBRARY SUPPLIES		589.85		N	
Vendor ID: DIETZE DIETZE MUSIC HOUSE						
Description:		Invoice Date:	Due Date:	Status:	1099 Amount:	0.00
Sequence: 1	Check Type:	Checking Account ID:	Check Number:	Check Date:		
<u>Chart of Account Number</u>	<u>Detail Description</u>	<u>Cost Center ID</u>	<u>Detail Amount</u>	<u>1099 Detail Amount</u>	<u>Asset/Asset Tag</u>	<u>In Full</u>
01 1100 430 000 0170 0 000	INSTRUMENT REPAIRS		593.64		N	
Vendor ID: EAKESO EAKES OFFICE SOLUTIONS						
Description:		Invoice Date:	Due Date:	Status:	1099 Amount:	0.00
Sequence: 1	Check Type:	Checking Account ID:	Check Number:	Check Date:		
<u>Chart of Account Number</u>	<u>Detail Description</u>	<u>Cost Center ID</u>	<u>Detail Amount</u>	<u>1099 Detail Amount</u>	<u>Asset/Asset Tag</u>	<u>In Full</u>
01 6997 610 000 0000 0 000	ANTI BACTERIAL SOAP		628.60		N	
01 2590 443 000 0000 0 000	COPIER CONTRACTS		675.19		N	
Vendor ID: ESU7NETWOR EDUCATIONAL SERVICE UNIT #7						
Description:		Invoice Date:	Due Date:	Status:	1099 Amount:	0.00
Sequence: 1	Check Type:	Checking Account ID:	Check Number:	Check Date:		
<u>Chart of Account Number</u>	<u>Detail Description</u>	<u>Cost Center ID</u>	<u>Detail Amount</u>	<u>1099 Detail Amount</u>	<u>Asset/Asset Tag</u>	<u>In Full</u>
01 2224 382 000 0000 0 000	NETWORK NE APR - JUNE		697.47		N	
01 2230 352 000 0000 0 000	NETWORK OPERATIONS		37.50		N	
01 2230 650 000 0000 0 000	IT GLUE		20.00		N	
Vendor ID: ESU7SP EDUCATIONAL SERVICE UNIT #7						
Description:		Invoice Date:	Due Date:	Status:	1099 Amount:	25,329.36
Sequence: 1	Check Type:	Checking Account ID:	Check Number:	Check Date:		
<u>Chart of Account Number</u>	<u>Detail Description</u>	<u>Cost Center ID</u>	<u>Detail Amount</u>	<u>1099 Detail Amount</u>	<u>Asset/Asset Tag</u>	<u>In Full</u>

01 1292 591 000 0000 0 000 0-2 SPED SERVICES 232.00 N 232.00 N
01 1291 591 000 0000 0 000 S.A. SPED SERVICES 4,659.72 N 4,659.72 N
01 1200 591 000 0000 0 000 SPED SERVICES 16,181.96 N 16,181.96 N
01 2141 591 000 0000 0 000 SPED S.A. PSYCH 4,255.68 N 4,255.68 N

Vendor ID: EGAN EGAN SUPPLY CO. **Invoice Number: 332653** **Amount: 1,628.80**

Description: PO Number: Invoice Date: 03/10/2021 Due Date: 03/15/2021 Status: A 1099 Amount: 0.00
Sequence: 1 Check Type: Checking Account ID: Invoice Number: 31021 Amount: 1,628.80
Chart of Account Number Detail Description PAPER PRODUCTS 1,628.80 N

Vendor ID: EVANSBRIAN EVANS, BRIAN **Invoice Number: 31021** **Amount: 1,140.54**

Description: PO Number: Invoice Date: 03/10/2021 Due Date: 03/15/2021 Status: A 1099 Amount: 0.00
Sequence: 1 Check Type: Checking Account ID: Invoice Number: 31021 Amount: 1,140.54
Chart of Account Number Detail Description HSA - MAR 2021 1,140.54 N

Vendor ID: FISCHBACHK FISCHBACH, KASEY **Invoice Number: 31021** **Amount: 100.00**

Description: PO Number: Invoice Date: 03/10/2021 Due Date: 03/15/2021 Status: A 1099 Amount: 0.00
Sequence: 1 Check Type: Checking Account ID: Invoice Number: 31021 Amount: 100.00
Chart of Account Number Detail Description STRIV - GIRLS & BOYS BB 100.00 N

Vendor ID: FLUFFSTUFF FLUFF & STUFF, LLC **Invoice Number: 31021** **Amount: 150.00**

Description: PO Number: Invoice Date: 03/10/2021 Due Date: 03/15/2021 Status: A 1099 Amount: 0.00
Sequence: 1 Check Type: Checking Account ID: Invoice Number: 31021 Amount: 150.00
Chart of Account Number Detail Description COTTON CANDY FOR ELEM FUN NIGHT 150.00 N

Vendor ID: GABEL GABEL, GRANT **Invoice Number: 31021** **Amount: 1,531.44**

Description: PO Number: Invoice Date: 03/10/2021 Due Date: 03/15/2021 Status: A 1099 Amount: 0.00
Sequence: 1 Check Type: Checking Account ID: Invoice Number: 31021 Amount: 1,531.44
Chart of Account Number Detail Description HSA - MAR 2021 1,531.44 N

Vendor ID: PETTY GENERAL FUND-PETTY CASH **Invoice Number: 31021** **Amount: 333.30**

Description: PO Number: Invoice Date: 03/10/2021 Due Date: 03/15/2021 Status: A 1099 Amount: 0.00
Sequence: 1 Check Type: Checking Account ID: Invoice Number: 31021 Amount: 333.30
Chart of Account Number Detail Description STAFF MEAL - PTC 214.95 N
01 2410 610 002 0000 0 000 100th DAY OF SCHOOL SUPPLIES 58.95 N
01 2130 610 000 0000 0 000 HOT / COLD PACKS 59.40 N

Vendor ID: GLOCK GLOCK, DENISE **Invoice Number: 31021** **Amount: 1,531.44**

Description: PO Number: Invoice Date: 03/10/2021 Due Date: 03/15/2021 Status: A 1099 Amount: 0.00
Sequence: 1 Check Type: Checking Account ID: Invoice Number: 31021 Amount: 1,531.44

Invoice Listing - Detail
MARCH 2021 GENERAL FUND INVOICES

Sequence: 1	Check Type:	Check Number:	Check Date:	Invoice Number:	Amount:
<u>Chart of Account Number</u>	<u>Detail Description</u>	<u>Cost Center ID</u>	<u>Detail Amount</u>	<u>1099 Detail Amount</u>	<u>Asset/Asset Tag</u>
01 2410 281 002 0000 0 000	HSA - MAR 2021	1,531.44	N		In Full
Vendor ID: GOULDZACH	GOULD, ZACHARY	PO Number:	Invoice Number: 31021	Amount:	2,041.92
Description:		Invoice Date: 03/10/2021	Due Date: 03/15/2021	Status: A	1099 Amount: 0.00
Sequence: 1	Check Type:	Check Number:	Check Date:		
<u>Chart of Account Number</u>	<u>Detail Description</u>	<u>Cost Center ID</u>	<u>Detail Amount</u>	<u>1099 Detail Amount</u>	<u>Asset/Asset Tag</u>
01 1100 281 001 0000 0 000	HSA - MAR 2021	2,041.92	N		In Full
Vendor ID: HOMETO	HOMETOWN LEASING	PO Number:	Invoice Number: 31021	Amount:	736.27
Description:		Invoice Date: 03/10/2021	Due Date: 03/15/2021	Status: A	1099 Amount: 0.00
Sequence: 1	Check Type:	Check Number:	Check Date:		
<u>Chart of Account Number</u>	<u>Detail Description</u>	<u>Cost Center ID</u>	<u>Detail Amount</u>	<u>1099 Detail Amount</u>	<u>Asset/Asset Tag</u>
01 2590 443 000 0000 0 000	COPIER PAYMENTS	736.27	N		In Full
Vendor ID: JACKSO	JACKSON SERVICES, INC	PO Number:	Invoice Number: 4483690,4493258	Amount:	395.54
Description:		Invoice Date: 03/10/2021	Due Date: 03/15/2021	Status: A	1099 Amount: 0.00
Sequence: 1	Check Type:	Check Number:	Check Date:		
<u>Chart of Account Number</u>	<u>Detail Description</u>	<u>Cost Center ID</u>	<u>Detail Amount</u>	<u>1099 Detail Amount</u>	<u>Asset/Asset Tag</u>
01 2610 420 000 0000 0 000	MOPS & RUGS	395.54	N		In Full
Vendor ID: JAKUBM	JAKUB, MADISYN	PO Number:	Invoice Number: 31021	Amount:	1,520.72
Description:		Invoice Date: 03/10/2021	Due Date: 03/15/2021	Status: A	1099 Amount: 0.00
Sequence: 1	Check Type:	Check Number:	Check Date:		
<u>Chart of Account Number</u>	<u>Detail Description</u>	<u>Cost Center ID</u>	<u>Detail Amount</u>	<u>1099 Detail Amount</u>	<u>Asset/Asset Tag</u>
01 1100 281 002 0000 0 000	HSA - MAR 2021	1,520.72	N		In Full
Vendor ID: JENSESARA	JENSEN, SARA	PO Number:	Invoice Number: 31021	Amount:	1,531.44
Description:		Invoice Date: 03/10/2021	Due Date: 03/15/2021	Status: A	1099 Amount: 0.00
Sequence: 1	Check Type:	Check Number:	Check Date:		
<u>Chart of Account Number</u>	<u>Detail Description</u>	<u>Cost Center ID</u>	<u>Detail Amount</u>	<u>1099 Detail Amount</u>	<u>Asset/Asset Tag</u>
01 1100 281 001 0000 0 000	HSA - MAR 2021	1,531.44	N		In Full
Vendor ID: KSBSCHLAW	KSB SCHOOL LAW, PC, LLO	PO Number:	Invoice Number: 9708	Amount:	256.00
Description:		Invoice Date: 03/10/2021	Due Date: 03/15/2021	Status: A	1099 Amount: 256.00
Sequence: 1	Check Type:	Check Number:	Check Date:		
<u>Chart of Account Number</u>	<u>Detail Description</u>	<u>Cost Center ID</u>	<u>Detail Amount</u>	<u>1099 Detail Amount</u>	<u>Asset/Asset Tag</u>
01 2330 317 000 0000 0 000	LEGAL SERVICES	256.00	N		In Full
Vendor ID: LINGO	LINGO	PO Number:	Invoice Number: 31021	Amount:	227.68
Description:		Invoice Date: 03/10/2021	Due Date: 03/15/2021	Status: A	1099 Amount: 0.00
Sequence: 1	Check Type:	Check Number:	Check Date:		
<u>Chart of Account Number</u>	<u>Detail Description</u>	<u>Cost Center ID</u>	<u>Detail Amount</u>	<u>1099 Detail Amount</u>	<u>Asset/Asset Tag</u>
01 2590 530 000 0000 0 000	LONG DISTANCE	227.68	N		In Full

Vendor ID: LUETTEL Description: LUETTEL, DANIELLE	PO Number: Invoice Date: 03/10/2021 <u>Cost Center ID</u>	Invoice Number: 31021 Due Date: 03/15/2021 <u>Detail Amount</u>	Status: A Check Date: 1099 Amount: 0.00	Amount: 1,531.44
Sequence: 1 <u>Chart of Account Number</u> 01 1100 281 002 0000 0 000	Checking Account ID: Check Number: <u>Detail Description</u> HSA - MAR 2021	Check Type: N		
Vendor ID: MATHESON Description: MATHESON TRI-GAS INC.	PO Number: Invoice Date: 03/10/2021 <u>Cost Center ID</u>	Invoice Number: 51762488 Due Date: 03/15/2021 <u>Detail Amount</u>	Status: A Check Date: 1099 Amount: 0.00	Amount: 838.04
Sequence: 1 <u>Chart of Account Number</u> 01 1100 610 001 0180 0 000	Checking Account ID: Check Number: <u>Detail Description</u> IND ARTS SUPPLIES	Check Type: N		
Vendor ID: MCILNA Description: MCILNAY & COMPANY	PO Number: Invoice Date: 03/10/2021 <u>Cost Center ID</u>	Invoice Number: 8393 Due Date: 03/15/2021 <u>Detail Amount</u>	Status: A Check Date: 1099 Amount: 0.00	Amount: 2,712.35
Sequence: 1 <u>Chart of Account Number</u> 01 2620 430 000 0000 0 000	Checking Account ID: Check Number: <u>Detail Description</u> REPLACED TOILETS	Check Type: N		
Vendor ID: MECHANICAL Description: MECHANICAL SALES, INC	PO Number: Invoice Date: 03/10/2021 <u>Cost Center ID</u>	Invoice Number: 51651 Due Date: 03/15/2021 <u>Detail Amount</u>	Status: A Check Date: 1099 Amount: 0.00	Amount: 660.50
Sequence: 1 <u>Chart of Account Number</u> 01 2620 430 000 0000 0 000	Checking Account ID: Check Number: <u>Detail Description</u> REPLACED SENSOR FOR HEATING UNIT	Check Type: N		
Vendor ID: MENARD Description: MENARDS	PO Number: Invoice Date: 03/10/2021 <u>Cost Center ID</u>	Invoice Number: 34920 Due Date: 03/15/2021 <u>Detail Amount</u>	Status: A Check Date: 1099 Amount: 0.00	Amount: 27.39
Sequence: 1 <u>Chart of Account Number</u> 01 1100 610 001 0180 0 000	Checking Account ID: Check Number: <u>Detail Description</u> IND ARTS SUPPLIES	Check Type: N		
Vendor ID: MIDAME Description: MID-AMERICAN RESEARCH CHEMICAL	PO Number: Invoice Date: 03/10/2021 <u>Cost Center ID</u>	Invoice Number: 0724275,0723842 Due Date: 03/15/2021 <u>Detail Amount</u>	Status: A Check Date: 1099 Amount: 0.00	Amount: 1,145.00
Sequence: 1 <u>Chart of Account Number</u> 01 6997 610 000 0000 0 000	Checking Account ID: Check Number: <u>Detail Description</u> CLEANING SUPPLIES	Check Type: N		
Vendor ID: MIDWESTALA Description: MIDWEST ALARM SERVICES	PO Number: Invoice Date: 03/10/2021 <u>Cost Center ID</u>	Invoice Number: 342355 Due Date: 03/15/2021 <u>Detail Amount</u>	Status: A Check Date: 1099 Amount: 0.00	Amount: 122.37
Sequence: 1 <u>Chart of Account Number</u> 01 2670 352 000 0000 0 000	Checking Account ID: Check Number: <u>Detail Description</u> FIRE ALARM MONITORING MAR-MAY	Check Type: N		
Vendor ID: MORNERAUND Description: MORNER, AUNDREA	PO Number: Invoice Date: 03/10/2021 <u>Cost Center ID</u>	Invoice Number: 31021 Due Date: 03/15/2021 <u>Detail Amount</u>	Status: A Check Date: 1099 Amount: 0.00	Amount: 543.24
Sequence: 1 <u>Chart of Account Number</u> 01 2670 352 000 0000 0 000	Checking Account ID: Check Number: <u>Detail Description</u> FIRE ALARM MONITORING MAR-MAY	Check Type: N		

<u>Chart of Account Number</u>	<u>Detail Description</u>	<u>Cost Center ID</u>	<u>Detail Amount</u>	<u>1099 Detail Amount</u>	<u>Asset/Asset Tag</u>	<u>In Full</u>
01 1100 281 001 0000 0 000	HSA - MAR 2021		543.24		N	
Vendor ID: NAPA AUTO	NAPA AUTO AND TRUCK PARTS	PO Number:	Invoice Number: 694256	Amount:		119.88
Description:		Invoice Date: 03/10/2021	Due Date: 03/15/2021	Status: A	1099 Amount: 0.00	
Sequence: 1	Check Type:	Checking Account ID:	Check Number:	Check Date:		
<u>Chart of Account Number</u>	<u>Detail Description</u>	<u>Cost Center ID</u>	<u>Detail Amount</u>	<u>1099 Detail Amount</u>	<u>Asset/Asset Tag</u>	<u>In Full</u>
01 2710 610 000 0000 0 000	DSL FA		119.88		N	
Vendor ID: NEASB	NEBRASKA ASSOCIATION OF SCHOOL BOARDS	PO Number:	Invoice Number: 07245,07503,07508	Amount:		280.00
Description:		Invoice Date: 03/10/2021	Due Date: 03/15/2021	Status: A	1099 Amount: 0.00	
Sequence: 1	Check Type:	Checking Account ID:	Check Number:	Check Date:		
<u>Chart of Account Number</u>	<u>Detail Description</u>	<u>Cost Center ID</u>	<u>Detail Amount</u>	<u>1099 Detail Amount</u>	<u>Asset/Asset Tag</u>	<u>In Full</u>
01 2320 810 000 0000 0 000	BUDGET & FINANCE WORKSHOP & RETREAT		280.00		N	
Vendor ID: NIENHUESER	NIENHUESER, KATE	PO Number:	Invoice Number: 31021	Amount:		1,140.54
Description:		Invoice Date: 03/10/2021	Due Date: 03/15/2021	Status: A	1099 Amount: 1,140.54	
Sequence: 1	Check Type:	Checking Account ID:	Check Number:	Check Date:		
<u>Chart of Account Number</u>	<u>Detail Description</u>	<u>Cost Center ID</u>	<u>Detail Amount</u>	<u>1099 Detail Amount</u>	<u>Asset/Asset Tag</u>	<u>In Full</u>
01 2120 281 002 0000 0 000	HSA - MAR 2021		1,140.54		N	
Vendor ID: ORKINP	ORKIN PEST CONTROL	PO Number:	Invoice Number: 210025871	Amount:		91.17
Description:		Invoice Date: 03/10/2021	Due Date: 03/15/2021	Status: A	1099 Amount: 0.00	
Sequence: 1	Check Type:	Checking Account ID:	Check Number:	Check Date:		
<u>Chart of Account Number</u>	<u>Detail Description</u>	<u>Cost Center ID</u>	<u>Detail Amount</u>	<u>1099 Detail Amount</u>	<u>Asset/Asset Tag</u>	<u>In Full</u>
01 2610 420 000 0000 0 000	PEST CONTROL		91.17		N	
Vendor ID: OSANTOWKEE	OSANTOWSKI, KEEGAN	PO Number:	Invoice Number: 31021	Amount:		200.00
Description:		Invoice Date: 03/10/2021	Due Date: 03/15/2021	Status: A	1099 Amount: 0.00	
Sequence: 1	Check Type:	Checking Account ID:	Check Number:	Check Date:		
<u>Chart of Account Number</u>	<u>Detail Description</u>	<u>Cost Center ID</u>	<u>Detail Amount</u>	<u>1099 Detail Amount</u>	<u>Asset/Asset Tag</u>	<u>In Full</u>
01 1100 151 000 0000 0 000	STRIV - GIRLS & BOYS BB		200.00		N	
Vendor ID: PATTERSONM	PATTERSON, MALLORY	PO Number:	Invoice Number: 31021	Amount:		724.32
Description:		Invoice Date: 03/10/2021	Due Date: 03/15/2021	Status: A	1099 Amount: 0.00	
Sequence: 1	Check Type:	Checking Account ID:	Check Number:	Check Date:		
<u>Chart of Account Number</u>	<u>Detail Description</u>	<u>Cost Center ID</u>	<u>Detail Amount</u>	<u>1099 Detail Amount</u>	<u>Asset/Asset Tag</u>	<u>In Full</u>
01 1100 281 002 0000 0 000	HSA - MAR 2021		724.32		N	
Vendor ID: PAYFLEX	PAY FLEX	PO Number:	Invoice Number: 31021	Amount:		100.00
Description:		Invoice Date: 03/10/2021	Due Date: 03/15/2021	Status: A	1099 Amount: 0.00	
Sequence: 1	Check Type:	Checking Account ID:	Check Number:	Check Date:		
<u>Chart of Account Number</u>	<u>Detail Description</u>	<u>Cost Center ID</u>	<u>Detail Amount</u>	<u>1099 Detail Amount</u>	<u>Asset/Asset Tag</u>	<u>In Full</u>
01 1100 291 000 0000 0 000	ADMIN FEE		100.00		N	

Vendor ID: PINNACLEOM PINNACLE BANK **PO Number: 31021** **Invoice Number: 31021** **Amount: 1,255.91**
Description: Invoice Date: 03/10/2021 Due Date: 03/15/2021 Status: A 1099 Amount: 0.00
Sequence: 1 Check Type: Checking Account ID: Check Number: Check Date:
Chart of Account Number Detail Description Cost Center ID Detail Amount 1099 Detail Amount Asset/Asset Tag In Full
01 2590 643 000 0000 0 000 BAMBOO 370.00 N
01 2710 626 000 0000 0 000 GAS - PICKING UP NEW BUS 100.07 N
01 2710 890 000 0000 0 000 TIRE FEE 16.40 N
01 2230 734 000 0000 0 000 STRIV COMPUTER 769.44 N

Vendor ID: PITBOW PITNEY BOWES **PO Number: 3313035934** **Invoice Number: 3313035934** **Amount: 210.96**
Description: Invoice Date: 03/10/2021 Due Date: 03/15/2021 Status: A 1099 Amount: 0.00
Sequence: 1 Check Type: Checking Account ID: Check Number: Check Date:
Chart of Account Number Detail Description Cost Center ID Detail Amount 1099 Detail Amount Asset/Asset Tag In Full
01 2590 443 000 0000 0 000 POSTAGE MACHINE LEASE 210.96 N

Vendor ID: POLKORPP POLK CO. RURAL PUBLIC POWER DISTRICT **PO Number: 31021** **Invoice Number: 31021** **Amount: 12,284.26**
Description: Invoice Date: 03/10/2021 Due Date: 03/15/2021 Status: A 1099 Amount: 0.00
Sequence: 1 Check Type: Checking Account ID: Check Number: Check Date:
Chart of Account Number Detail Description Cost Center ID Detail Amount 1099 Detail Amount Asset/Asset Tag In Full
01 2610 621 000 0000 0 000 ELECTRICITY 12,284.26 N

Vendor ID: PRAIRI PRAIRIE CREEK FAMILY MEDICINE **PO Number: 31021** **Invoice Number: 31021** **Amount: 120.00**
Description: Invoice Date: 03/10/2021 Due Date: 03/15/2021 Status: A 1099 Amount: 0.00
Sequence: 1 Check Type: Checking Account ID: Check Number: Check Date:
Chart of Account Number Detail Description Cost Center ID Detail Amount 1099 Detail Amount Asset/Asset Tag In Full
01 2710 290 000 0000 0 000 RASMUSSEN BUS PHYSICAL 120.00 N

Vendor ID: RASMUSJOHN RASMUSSEN, JOHN **PO Number: 31021** **Invoice Number: 31021** **Amount: 59.50**
Description: Invoice Date: 03/10/2021 Due Date: 03/15/2021 Status: A 1099 Amount: 0.00
Sequence: 1 Check Type: Checking Account ID: Check Number: Check Date:
Chart of Account Number Detail Description Cost Center ID Detail Amount 1099 Detail Amount Asset/Asset Tag In Full
01 2710 890 000 0000 0 000 REIMBURSEMENT FOR COMMERCIAL DRIVERS LIS 59.50 N

Vendor ID: REALLY REALLY GOOD STUFF, LLC **PO Number: 6910204** **Invoice Number: 6910204** **Amount: 39.04**
Description: Invoice Date: 03/10/2021 Due Date: 03/15/2021 Status: A 1099 Amount: 0.00
Sequence: 1 Check Type: Checking Account ID: Check Number: Check Date:
Chart of Account Number Detail Description Cost Center ID Detail Amount 1099 Detail Amount Asset/Asset Tag In Full
01 2590 610 000 0000 0 000 SUPPLIES 39.04 N

Vendor ID: RIGGSJON RIGGS, JON **PO Number: 31021** **Invoice Number: 31021** **Amount: 1,531.44**
Description: Invoice Date: 03/10/2021 Due Date: 03/15/2021 Status: A 1099 Amount: 0.00
Sequence: 1 Check Type: Checking Account ID: Check Number: Check Date:
Chart of Account Number Detail Description Cost Center ID Detail Amount 1099 Detail Amount Asset/Asset Tag In Full
01 1100 281 002 0000 0 000 HSA - MAR 2021 1,531.44 N

Vendor ID: SCHUETHB	SCHUETH, BECKY	PO Number:	Invoice Number: 31021	Amount:	1,531.44
Description:		Invoice Date: 03/10/2021	Due Date: 03/15/2021	Status: A	1099 Amount: 0.00
Sequence: 1	Check Type:	Check Number:	Check Date:		
<u>Chart of Account Number</u>	<u>Detail Description</u>	<u>Cost Center ID</u>	<u>1099 Detail Amount</u>	<u>Asset/Asset Tag</u>	<u>In Full</u>
01 1100 281 001 0000 0 000	HSA - MAR 2021	1,531.44	N		
Vendor ID: SEGNERMORG	SEGNER, MORGAN	PO Number:	Invoice Number: 31021	Amount:	1,531.44
Description:		Invoice Date: 03/10/2021	Due Date: 03/15/2021	Status: A	1099 Amount: 0.00
Sequence: 1	Check Type:	Check Number:	Check Date:		
<u>Chart of Account Number</u>	<u>Detail Description</u>	<u>Cost Center ID</u>	<u>1099 Detail Amount</u>	<u>Asset/Asset Tag</u>	<u>In Full</u>
01 1100 281 001 0000 0 000	HSA - MAR 2021	1,531.44	N		
Vendor ID: SHELBYAUTO	SHELBY AUTO CLINIC	PO Number:	Invoice Number: 035044034472034487	Amount:	649.90
Description:		Invoice Date: 03/10/2021	Due Date: 03/15/2021	Status: A	1099 Amount: 225.00
Sequence: 1	Check Type:	Check Number:	Check Date:		
<u>Chart of Account Number</u>	<u>Detail Description</u>	<u>Cost Center ID</u>	<u>1099 Detail Amount</u>	<u>Asset/Asset Tag</u>	<u>In Full</u>
01 2710 626 000 0000 0 000	OIL	336.88	N		
01 2730 431 000 0000 0 000	REPAIRS	313.02	225.00	N	
Vendor ID: SHELBS	SHELBY LUMBER CO.	PO Number:	Invoice Number: 110080,109970,109911	Amount:	88.40
Description:		Invoice Date: 03/10/2021	Due Date: 03/15/2021	Status: A	1099 Amount: 0.00
Sequence: 1	Check Type:	Check Number:	Check Date:		
<u>Chart of Account Number</u>	<u>Detail Description</u>	<u>Cost Center ID</u>	<u>1099 Detail Amount</u>	<u>Asset/Asset Tag</u>	<u>In Full</u>
01 2610 610 000 0000 0 000	SUPPLIES	88.40	N		
Vendor ID: SMITHELECT	SMITH ELECTRIC	PO Number:	Invoice Number: 2405	Amount:	390.00
Description:		Invoice Date: 03/10/2021	Due Date: 03/15/2021	Status: A	1099 Amount: 0.00
Sequence: 1	Check Type:	Check Number:	Check Date:		
<u>Chart of Account Number</u>	<u>Detail Description</u>	<u>Cost Center ID</u>	<u>1099 Detail Amount</u>	<u>Asset/Asset Tag</u>	<u>In Full</u>
01 2620 430 000 0000 0 000	FAN MOTOR REPLACEMENT KIT	390.00	N		
Vendor ID: SPARQDATA	SPARQ DATA SOLUTIONS	PO Number:	Invoice Number: 2182	Amount:	4,160.00
Description:		Invoice Date: 03/10/2021	Due Date: 03/15/2021	Status: A	1099 Amount: 0.00
Sequence: 1	Check Type:	Check Number:	Check Date:		
<u>Chart of Account Number</u>	<u>Detail Description</u>	<u>Cost Center ID</u>	<u>1099 Detail Amount</u>	<u>Asset/Asset Tag</u>	<u>In Full</u>
01 2310 643 000 0000 0 000	MEETING SUBSCRIPTION	4,160.00	N		
Vendor ID: STEWAR	STEWART, STACY	PO Number:	Invoice Number: 31021	Amount:	1,531.44
Description:		Invoice Date: 03/10/2021	Due Date: 03/15/2021	Status: A	1099 Amount: 0.00
Sequence: 1	Check Type:	Check Number:	Check Date:		
<u>Chart of Account Number</u>	<u>Detail Description</u>	<u>Cost Center ID</u>	<u>1099 Detail Amount</u>	<u>Asset/Asset Tag</u>	<u>In Full</u>
01 2151 281 000 0000 0 000	HSA - MAR 2021	1,531.44	N		
Vendor ID: STROMS	STROMSBURG WATER & CONDITIONING INC.	PO Number:	Invoice Number: 31021	Amount:	125.00
Description:		Invoice Date: 03/10/2021	Due Date: 03/15/2021	Status: A	1099 Amount: 0.00

Sequence: 1	Check Type:	Checking Account ID:	Check Number:	Check Date:	Cost Center ID	Detail Amount	1099 Detail Amount	Asset/Asset Tag	In Full
01 2610 610 000 0000 0 000			125.00						
Vendor ID: TILLEYSPRI	TILLEY SPRINKLERS & LANDSCAPING, INC		Invoice Number: 124786	Invoice Date: 03/10/2021	PO Number:	Due Date: 03/15/2021	Status: A	1099 Amount: 0.00	Amount: 1,530.00
Description:									
Sequence: 1	Check Type:	Checking Account ID:	Check Number:	Check Date:	Cost Center ID	Detail Amount	1099 Detail Amount	Asset/Asset Tag	In Full
01 2620 420 000 0000 0 000			1,530.00						
Vendor ID: TIROUTLET	TIRO OUTLET, INC.		Invoice Number: 187065	Invoice Date: 03/10/2021	PO Number:	Due Date: 03/15/2021	Status: A	1099 Amount: 0.00	Amount: 177.00
Description:									
Sequence: 1	Check Type:	Checking Account ID:	Check Number:	Check Date:	Cost Center ID	Detail Amount	1099 Detail Amount	Asset/Asset Tag	In Full
01 2730 431 000 0000 0 000			177.00						
Vendor ID: TONNIGESJ	TONNIGES, JORDAN		Invoice Number: 31021	Invoice Date: 03/10/2021	PO Number:	Due Date: 03/15/2021	Status: A	1099 Amount: 0.00	Amount: 1,531.44
Description:									
Sequence: 1	Check Type:	Checking Account ID:	Check Number:	Check Date:	Cost Center ID	Detail Amount	1099 Detail Amount	Asset/Asset Tag	In Full
01 1100 281 002 0000 0 000			1,531.44						
Vendor ID: TOPIIL	TOPIIL, SUE		Invoice Number: 31021	Invoice Date: 03/10/2021	PO Number:	Due Date: 03/15/2021	Status: A	1099 Amount: 0.00	Amount: 543.24
Description:									
Sequence: 1	Check Type:	Checking Account ID:	Check Number:	Check Date:	Cost Center ID	Detail Amount	1099 Detail Amount	Asset/Asset Tag	In Full
01 2590 280 000 0000 0 000			543.24						
Vendor ID: TROFHOLTZU	TROFHOLTZ, TURNER		Invoice Number: 31021	Invoice Date: 03/10/2021	PO Number:	Due Date: 03/15/2021	Status: A	1099 Amount: 0.00	Amount: 92.96
Description:									
Sequence: 1	Check Type:	Checking Account ID:	Check Number:	Check Date:	Cost Center ID	Detail Amount	1099 Detail Amount	Asset/Asset Tag	In Full
01 1100 333 000 0000 0 000			92.96						
Vendor ID: TRUCKCEN	TRUCK CENTER COMPANIES		Invoice Number: 227507J	Invoice Date: 03/10/2021	PO Number:	Due Date: 03/15/2021	Status: A	1099 Amount: 0.00	Amount: 193.80
Description:									
Sequence: 1	Check Type:	Checking Account ID:	Check Number:	Check Date:	Cost Center ID	Detail Amount	1099 Detail Amount	Asset/Asset Tag	In Full
01 2730 431 000 0000 0 000			193.80						
Vendor ID: UNOFKE	UNIVERSITY OF NEBRASKA - KEARNEY		Invoice Number: 31021	Invoice Date: 03/10/2021	PO Number:	Due Date: 03/15/2021	Status: A	1099 Amount: 0.00	Amount: 2,000.00
Description:									
Sequence: 1	Check Type:	Checking Account ID:	Check Number:	Check Date:	Cost Center ID	Detail Amount	1099 Detail Amount	Asset/Asset Tag	In Full
01 2213 330 000 0000 0 000			2,000.00						

CONTRACT

Vendor ID: VERIZON Description: VERIZON WIRELESS Sequence: 1 Check Type: <u>Chart of Account Number</u> 01 2710 530 000 0000 0 000	Checking Account ID: BUS PHONES	PO Number: Invoice Date: 03/10/2021 Due Date: 03/15/2021 Status: A 1099 Amount: 0.00 Check Number: <u>Detail Amount</u> 299.00 <u>Detail Amount Asset/Asset Tag</u> N	Invoice Number: 9874354311 Amount: 299.00
Vendor ID: VILLAGE Description: VILLAGE OF SHELBY Sequence: 1 Check Type: <u>Chart of Account Number</u> 01 2610 410 000 0000 0 000	Checking Account ID: WATER, SEWER & GARBAGE	PO Number: Invoice Date: 03/10/2021 Due Date: 03/15/2021 Status: A 1099 Amount: 485.00 Check Number: <u>Detail Amount</u> 1,131.18 <u>Detail Amount Asset/Asset Tag</u> 485.00 N	Invoice Number: 234490 Amount: 1,131.18
Vendor ID: VOSSLEYTON Description: VOSS, LEYTON Sequence: 1 Check Type: <u>Chart of Account Number</u> 01 1100 151 000 0000 0 000	Checking Account ID: STRIV - GIRLS & BOYS BB, ONE ACT	PO Number: Invoice Date: 03/10/2021 Due Date: 03/15/2021 Status: A 1099 Amount: 0.00 Check Number: <u>Detail Amount</u> 140.00 <u>Detail Amount Asset/Asset Tag</u> N	Invoice Number: 31021 Amount: 140.00
Vendor ID: VOSSSANDY Description: VOSS, SANDY Sequence: 1 Check Type: <u>Chart of Account Number</u> 01 2120 281 001 0000 0 000	Checking Account ID: HSA - MAR 2021	PO Number: Invoice Date: 03/10/2021 Due Date: 03/15/2021 Status: A 1099 Amount: 0.00 Check Number: <u>Detail Amount</u> 1,531.44 <u>Detail Amount Asset/Asset Tag</u> N	Invoice Number: 31021 Amount: 1,531.44
Vendor ID: WETJENALEX Description: WETJEN, ALEXIS Sequence: 1 Check Type: <u>Chart of Account Number</u> 01 1100 151 000 0000 0 000	Checking Account ID: STRIV - GIRLS & BOYS BB, WRESTLING	PO Number: Invoice Date: 03/10/2021 Due Date: 03/15/2021 Status: A 1099 Amount: 0.00 Check Number: <u>Detail Amount</u> 315.00 <u>Detail Amount Asset/Asset Tag</u> N	Invoice Number: 31021 Amount: 315.00
Vendor ID: WETJENLILL Description: WETJEN, LILLIAN Sequence: 1 Check Type: <u>Chart of Account Number</u> 01 1100 151 000 0000 0 000	Checking Account ID: STRIV - GIRLS & BOYS BB, WRESTLING	PO Number: Invoice Date: 03/10/2021 Due Date: 03/15/2021 Status: A 1099 Amount: 0.00 Check Number: <u>Detail Amount</u> 180.00 <u>Detail Amount Asset/Asset Tag</u> N	Invoice Number: 31021 Amount: 180.00
Vendor ID: WICKHAMSEA Description: WICKHAM, SEAN Sequence: 1 Check Type: <u>Chart of Account Number</u> 01 1100 281 001 0000 0 000	Checking Account ID: HSA - MAR 2021	PO Number: Invoice Date: 03/10/2021 Due Date: 03/15/2021 Status: A 1099 Amount: 0.00 Check Number: <u>Detail Amount</u> 1,339.52 <u>Detail Amount Asset/Asset Tag</u> N	Invoice Number: 31021 Amount: 1,339.52
Vendor ID: WILTON Description: WILTON, KRISTEN Sequence: 1 Check Type: <u>Chart of Account Number</u> 01 1100 281 001 0000 0 000	Checking Account ID: HSA - MAR 2021	PO Number: Invoice Date: 03/10/2021 Due Date: 03/15/2021 Status: A 1099 Amount: 0.00 Check Number: <u>Detail Amount</u> 1,531.44 <u>Detail Amount Asset/Asset Tag</u> N	Invoice Number: 31021 Amount: 1,531.44

BUDGET REPORT
FEBRUARY 2021 GENERAL FUND

Account Number	Account Description BUDGETED	EXPENDED	TO DATE	BALANCE	
1100	REGULAR INSTRUCTIONAL PROGRAMS	\$3,058,492.00	\$226,719.52	\$1,458,857.88	\$1,599,634.12
1150	ENGLISH LANGUAGE LEARNERS	\$29,921.00	\$3,882.34	\$24,785.02	\$5,135.98
1160	POVERTY - After School Program	\$101,700.00	\$3,089.87	\$19,122.89	\$82,577.11
1190	PRESCHOOL	\$118,166.00	\$8,877.12	\$54,674.02	\$63,491.98
1100	REGULAR INSTRUCTIONAL PROGRAMS	\$3,308,279.00	\$242,568.85	\$1,557,439.81	\$1,750,839.19
1200	SPECIAL EDUCATION PROGRAMS	\$521,688.00	\$48,991.44	\$298,343.68	\$223,344.32
1291	SPED AGES 3-5	\$65,712.00	\$0.00	\$0.00	\$65,712.00
1292	SPED AGES 0-2	\$16,000.00	\$0.00	\$0.00	\$16,000.00
1295	UNIFIED SPORTS	\$1,700.00	\$0.00	\$1,056.52	\$643.48
1200	SPECIAL EDUCATION PROGRAMS	\$605,100.00	\$48,991.44	\$299,400.20	\$305,699.80
2120	GUIDANCE SERVICES	\$202,931.00	\$15,653.45	\$96,720.94	\$106,210.06
2130	HEALTH SERVICES	\$63,600.00	\$4,727.42	\$29,055.96	\$34,544.04
2141	SPED Psychological services - Age S.A.	\$45,454.00	\$0.00	\$0.00	\$45,454.00
2151	SPEECH PATHOLOGY - SPED SCHOOL AGE	\$101,657.00	\$7,461.76	\$46,086.35	\$55,570.65
2161	SPED Occupational Therapy - Age S.A.	\$12,000.00	\$1,780.04	\$10,563.70	\$1,436.30
2171	SPED Physical Therapy - Age S.A.	\$10,000.00	\$490.51	\$3,791.45	\$6,208.55
2100	SUPPORTIVE SERVICES PUPILS	\$435,642.00	\$30,825.61	\$189,559.25	\$246,082.75
2211	SCHOOL IMPROVEMENT	\$12,200.00	\$421.62	\$2,405.75	\$9,794.25
2212	INST STAFF TRNG AND CURR DEV	\$1,950.00	\$0.00	\$0.00	\$1,950.00
2213	INSTRUCTIONAL STAFF TRAINING	\$10,000.00	\$0.00	\$4,784.56	\$5,215.44
2214	IMPLEMENTATION OF STANDARDS	\$5,500.00	\$0.00	\$423.10	\$5,076.90
2220	LIBRARY/MEDIA SERVICE	\$112,663.00	\$10,705.65	\$52,857.61	\$59,805.39
2224	EDUCATIONAL TV SERVICES	\$7,000.00	\$0.00	\$1,419.94	\$5,580.06
2230	INSTRUCTION RELATED TECHNOLOGY	\$129,912.00	\$13,775.50	\$64,984.28	\$64,927.72
2240	ACADEMIC STUDENT ASSESSMENT	\$9,750.00	\$322.00	\$322.00	\$9,428.00
2200	SUPPORT SERVICES STAFF	\$288,975.00	\$25,224.77	\$127,197.24	\$161,777.76
2310	BOARD OF EDUCATION	\$47,900.00	\$5,191.79	\$37,508.51	\$10,391.49
2320	EXECUTIVE ADMINISTRATION	\$150,700.00	\$12,520.37	\$74,315.47	\$76,384.53
2330	DISTRICT LEGAL SERVICES	\$20,000.00	\$0.00	\$2,570.00	\$17,430.00
2300	SUPPORT SERVICES-GEN ADMIN	\$218,600.00	\$17,712.16	\$114,393.98	\$104,206.02
2410	OFFICE OF THE PRINCIPAL	\$267,302.00	\$20,970.77	\$130,567.28	\$136,734.72
2490	SCHOOL ADMIN - OTHER	\$0.00	\$1,285.59	\$1,652.62	(\$1,652.62)
2400	OFFICE OF PRINCIPAL	\$267,302.00	\$22,256.36	\$132,219.90	\$135,082.10
2590	GENERAL ADMIN - BUSINESS SERVICE	\$284,100.00	\$19,733.05	\$125,946.15	\$158,153.85
2500	SUPPORT SERVICES-BUSINESS	\$284,100.00	\$19,733.05	\$125,946.15	\$158,153.85
2610	OPERATION OF PLANT	\$517,200.00	\$38,461.37	\$224,324.40	\$292,875.60
2620	MAINTENANCE OF PLANT	\$87,500.00	\$14,346.65	\$26,024.90	\$61,475.10
2650	GENERAL PURPOSE VEHICLES	\$2,800.00	\$64,400.00	\$80,846.20	(\$78,046.20)
2660	SECURITY	\$5,100.00	\$0.00	\$0.00	\$5,100.00
2670	SCHOOL SAFETY	\$3,500.00	\$120.00	\$1,101.66	\$2,398.34
2600	SUPPORT SERVICES-BLDGS & SITES	\$616,100.00	\$117,328.02	\$332,297.16	\$283,802.84
2710	Pupil Transportation - Regular ED	\$196,500.00	\$12,320.50	\$101,143.49	\$95,356.51
2712	SCHOOL AGE SPEC ED TRANSPORT	\$76,550.00	\$994.81	\$5,418.45	\$71,131.55
2700	SUPPORT SERVICES-PUPIL TRANS	\$273,050.00	\$19,507.89	\$114,758.54	\$158,291.46
3100	Food Service Operations	\$0.00	(\$6,152.97)	\$84.89	(\$84.89)
3100	Food Service Operations	\$0.00	(\$6,152.97)	\$84.89	(\$84.89)
3500	Other State Categorical Programs	\$0.00	\$643.88	\$643.88	(\$643.88)
3535	HIGH ABILITY	\$4,000.00	\$0.00	\$0.00	\$4,000.00
3500	Other State Categorical Programs	\$4,000.00	\$643.88	\$643.88	\$3,356.12
4500	BUILDING CONSTRUCTION	\$60,000.00	\$0.00	\$0.00	\$60,000.00
4599	ARRA STABILIZATION	\$0.00	\$0.00	\$0.00	\$0.00
4500	BUILDING CONSTRUCTION	\$60,000.00	\$0.00	\$0.00	\$60,000.00
4600	SITE IMPROVEMENTS	\$10,000.00	\$0.00	\$0.00	\$10,000.00
4630	ARRA 3-5 EXPENSES	\$0.00	\$0.00	\$0.00	\$0.00
4600	SITE IMPROVEMENTS	\$10,000.00	\$0.00	\$0.00	\$10,000.00
6200	TITLE I	\$128,017.00	\$9,700.31	\$60,608.49	\$67,408.51
6200	TITLE I	\$128,017.00	\$9,700.31	\$60,608.49	\$67,408.51
6406	IDEA 3-5 SPED	\$3,459.00	\$2,631.98	\$19,619.60	(\$16,160.60)
6408	IDEA PART B 0-21	\$83,031.00	\$609.50	\$8,838.12	\$74,192.88
6400	6400	\$86,490.00	\$3,241.48	\$28,457.72	\$58,032.28
6992	REAP - FEDERAL SERVICES	\$30,806.00	\$0.00	\$0.00	\$30,806.00
6900	6900	\$30,806.00	\$0.00	\$0.00	\$30,806.00
8000	TRANSFERS	\$25,000.00	\$0.00	\$0.00	\$25,000.00
8000	TRANSFERS	\$25,000.00	\$0.00	\$0.00	\$25,000.00
01	GENERAL FUND	\$6,641,461.00	\$551,580.85	\$3,083,007.21	\$3,558,453.79

Revenue Summary Report
FEBRUARY 2021 GENERAL FUND

Fund: 01 GENERAL FUND

<u>Account Number</u>	<u>Description</u>	<u>During Month</u>	<u>To Date</u>	<u>Budget Balance</u>
01 1100	LEVIED TAXES	276,827.75	2,858,271.26	(2,858,271.26)
01 1115	CARLINE TAX	0.00	715.69	(715.69)
01 1120	PUBLIC POWER DIST. TAX	21,359.37	27,246.17	(27,246.17)
01 1125	MOTOR VEHICLES TAX	45,608.58	135,129.41	(135,129.41)
01 1140	INTEREST	1,505.84	6,442.79	(6,442.79)
01 1370	PRESCHOOL TUITION	0.00	2,526.93	(2,526.93)
01 1510	INTEREST ON INVESTMENT	104.08	559.19	(559.19)
01 1990	OTHER LOCAL RECEIPTS	272.10	1,555.50	(1,555.50)
	Subtota LOCAL RECIEPTS	345,677.72	3,032,446.94	(3,032,446.94)
01 2110	FINES & LICENSE FEES	1,125.07	40,113.87	(40,113.87)
01 2210	ESU RECEIPTS	105.78	428.67	(428.67)
	Subtota COUNTY AND ESU RECEIPTS	1,230.85	40,542.54	(40,542.54)
01 3110	STATE AID	64,590.00	387,540.00	(387,540.00)
01 3120	SPECIAL ED. PROGRAMS	31,610.00	97,663.00	(97,663.00)
01 3131	PROPERTY TAX CREDIT	228,322.69	228,322.69	(228,322.69)
01 3180	PRO-RATA MOTOR VEHICLE	0.00	3,838.98	(3,838.98)
01 3400	STATE APPORTIONMENT TAX	44,041.11	44,041.11	(44,041.11)
01 3535	HIGH ABILITY LEARNERS	0.00	2,342.00	(2,342.00)
	Subtota STATE RECEIPTS	368,563.80	763,747.78	(763,747.78)
01 4516	IDEA 4406	0.00	3,426.00	(3,426.00)
01 4518	IDEA PART B	80,102.00	80,102.00	(80,102.00)
01 4708	MEDICAID	0.00	1,980.57	(1,980.57)
	Subtota FEDERAL RECEIPTS	80,102.00	85,508.57	(85,508.57)
01 5301	INSURANCE ADJUSTMENTS	0.00	19,894.58	(19,894.58)
01 5690	OTHER NON-REVENUE RECEIPTS	3,336.84	53,509.38	(53,509.38)
	Subtota NON-REVENUE RECEIPTS	3,336.84	73,403.96	(73,403.96)
	Fund Total:	798,911.21	3,995,649.79	(3,995,649.79)

SHELBY- RISING CITY PUBLIC SCHOOLS
FINANCIAL REPORT
NUTRITION FUND

Beginning Balance 02/01/21

\$ 70,098.87

RECEIPTS:

	AMOUNT
Online lunch Payments	\$ 60.00
State of NE reimbursement	\$ 18,608.81
Interest	\$ 2.16

\$ 18,670.97

Total Receipts

DISBURSEMENTS:

Name:	Ck No.	AMOUNT
Hiland Dairy Foods	2932	\$ 1,954.56
CWD Cash-Wa Distributing	2933	\$ 6,954.78
CWD Cash-Wa Distributing	2934	\$ 16,800.00
US Foods	2935	\$ 3,280.43
Bimbo Bakeries USA	2937	\$ 834.58
Noyd Repair	2938	\$ 64.00
Connecting Point	2939	\$ 859.99
Educational Biometric Technology	2940	\$ 350.00
Cubby's	2941	\$ 45.26
SRC General Fund	2942	\$ 12,426.42
Magic Wrighter	5582	\$ 20.00

\$ 43,590.02

Ending Balance 02/28/21

\$ 45,179.82

**SHELBY-RISING CITY PUBLIC SCHOOL
FINANCIAL REPORT
GENERAL FUND - PETTY CASH**

Balance 02/01/21 \$ 8,302.61

RECEIPTS:

General Fund Reimburesment	\$ 519.00
Scholastic Book Fair	\$ 2,217.46

Total Receipts: \$ 2,736.46

DISBURSEMENTS:

Kristen Wilton - EHA	\$ 212.50
Amy Pospisil - EHA	\$ 212.50
Lynn Blex - EHA	\$ 212.50
Jordan Tonniges - EHA	\$ 212.50
Scholastic Book Fair	\$ 2,217.46
Hy-Vee	\$ 214.95
Wal-Mart	\$ 118.35
Jeanne Kay - EHA	\$ 212.50
Brian Evans - EHA	\$ 212.50
Capital One	\$ 32.09

Total Disbursements: \$ 3,857.85

Balance: 02/28/21 \$ 7,181.22

Special Deposits:

EHA Wellness Grant	\$ 1,275.50
--------------------	---------------

**SHELBY-RISING CITY PUBLIC SCHOOL
FINANCIAL REPORT
BUILDING FUND**

Balance 02/01/21 \$ 175,169.87

RECEIPTS:

Polk County Treasurer	\$	9,825.93
Butler County Treasurer	\$	5,983.24
Interest	\$	7.10

Total Receipts: \$ 15,816.27

DISBURSEMENTS:

Total Disbursements: \$ -

Balance: 02/29/21 \$ 190,986.14

**SHELBY- RISING CITY PUBLIC SCHOOL
FINANCIAL REPORT
DEPRECIATION FUND
February 28, 2021**

	Beginning Balance:	\$	272,419.20
RECEIPTS:			
C.O.D. Interest	\$	42.41	
Interest	\$	52.25	
<u>Total Receipts:</u>		\$	94.66
DISBURSEMENTS:			
<u>Total Disbursements:</u>			
	Ending Balance:	\$	<u>272,513.86</u>
Certificate of Deposit			\$172,000.00
	Total Balance	\$	<u>444,513.86</u>

**SHELBY-RISING CITY PUBLIC SCHOOL
FINANCIAL REPORT
GENERAL FUND - BOND**

Balance 02/01/21 \$ 340,294.61

RECEIPTS:

Polk Co. Treas.	\$ 60,547.41
Butler Co. Treas.	\$ 36,736.95
Interest	\$ 15.38

Total Receipts: \$ 97,299.74

DISBURSEMENTS:

Total Disbursements: \$ -

Balance: 02/28/21 \$ 437,594.35

**SHELBY-RISING CITY PUBLIC SCHOOL
FINANCIAL REPORT
EMPLOYEE BENEFIT ACCOUNT**

Beginning Balance 2/01/21: \$ 14,673.34

Receipts:

General Fund \$ 3,956.07

Total Received: \$ 3,956.07

Expended Out:

Monthly Claims \$ 286.62

Monthly Claims \$ 255.00

Monthly Claims \$ 368.28

Monthly Claims \$ 1,487.18

Total Expended Out: \$ 2,397.08

Ending Balance 2/28/21: \$ 16,232.33

SUMMARY SHEET

February 28, 2021

Account Name:	Amount	Amount to CD
General Fund	\$ 2,657,272.28	
General Fund Savings	\$ 9,035.76	
Lunch Fund	\$ 45,179.82	
Petty Cash	\$ 7,181.22	
Building	\$ 190,986.14	
Depreciation	\$ 272,513.86	\$ 172,000.00
Employment Benefit	\$ 16,232.33	
Bond	\$ 437,594.35	
Activity Fund	\$ 98,858.87	\$ 38,000.00
<u>Total of Accounts</u>	<u>\$ 3,734,854.63</u>	<u>\$ 210,000.00</u>
<u>Total of All Accounts</u>		<u>\$ 3,944,854.63</u>

<u>Account Number</u>	<u>Description</u>	<u>Previous Balance</u>	<u>Current Month</u>	<u>Ending Balance</u>
Fund: 05 ACTIVITIES FUND				
<u>Current Assets</u>				
05 101	CASH/ACTIVITY FUND	132,351.33	4,544.42	136,895.75
	Current Assets Subtotal:	<u>132,351.33</u>	<u>4,544.42</u>	<u>136,895.75</u>
Total Assets and Deferred Outflows of Resources:		<u>132,351.33</u>	<u>4,544.42</u>	<u>136,895.75</u>
<u>Fund Balance</u>				
05 704 0434	FUND BALANCE/CD	299.00	0.00	299.00
05 704 4010	FUND BALANCE - ATHLETICS	(614.21)	3,245.74	2,631.53
05 704 4020	FUND BALANCE - CONCESSION	2,774.66	3,659.91	6,434.57
05 704 4030	FUND BALANCE - NHS	834.63	(250.00)	584.63
05 704 4040	FUND BALANCE - SRC CLUB	5,539.35	0.00	5,539.35
05 704 4050	FUND BALANCE - CLASS OF 2023	2,251.19	0.00	2,251.19
05 704 4060	FUND BALANCE - CLASS OF 2021	2,683.52	0.00	2,683.52
05 704 4070	FUND BALANCE - JUST FOR KIDS	1,315.95	0.00	1,315.95
05 704 4080	FUND BALANCE - CLASS OF 2020	505.00	0.00	505.00
05 704 4090	FUND BALANCE - CLASS OF 2022	4,060.19	0.00	4,060.19
05 704 4100	FUND BALANCE - YEARBOOK	3,186.19	0.00	3,186.19
05 704 4110	FUND BALANCE - MUSIC	96.70	0.00	96.70
05 704 4120	FUND BALANCE - STUDENT COUNCIL	5,417.26	0.00	5,417.26
05 704 4130	FUND BALANCE - DANCE TEAM	577.17	(877.50)	(300.33)
05 704 4140	FUND BALANCE -MEMORIALS	2,830.28	0.00	2,830.28
05 704 4150	FUND BALANCE - DRUG & ALCHOL PREVENTION	2,596.52	0.00	2,596.52
05 704 4160	FUND BALANCE - SHOP	11,639.39	(124.35)	11,515.04
05 704 4170	FUND BALANCE - INTEREST	556.50	8.83	565.33
05 704 4180	FUND BALANCE - BOOK IT	495.92	0.00	495.92
05 704 4190	FUND BALANCE/SPEECH AND DRAMA	(1,142.96)	(2,399.00)	(3,541.96)
05 704 4200	FUND BALANCE - LAP TOP LEASE FEE	9,449.11	0.00	9,449.11
05 704 4210	FUND BALANCE - WELLNESS CENTER	20,311.27	0.00	20,311.27
05 704 4220	FUND BALANCE - FBLA	6,765.52	1,280.79	8,046.31
05 704 4230	FUND BALANCE - STAFF DEVELOPMENT	(154.19)	0.00	(154.19)
05 704 4240	FUND BALANCE - QUIZ BOWL	20.00	0.00	20.00
05 704 4250	FUND BALANCE - ALUMNI	1,141.01	0.00	1,141.01
05 704 4260	FUND BALANCE - VIDEO BOARD	6,855.87	0.00	6,855.87
05 704 4270	FUND BALANCE - FFA	21,980.00	0.00	21,980.00
05 704 4280	FUND BALANCE - CIRCLE OF FRIENDS	67.14	0.00	67.14
05 704 4290	FUND BALANCE - STUDENT FEES	10,868.59	0.00	10,868.59
05 704 4300	FUND BALANCE - FACILITY RENTAL	1,290.00	0.00	1,290.00
05 704 4310	FUND BALANCE - SUPERINTENDENT	7,239.25	0.00	7,239.25
05 704 4320	FUND BALANCE - UNIFIED BOWLING	615.51	0.00	615.51
	Fund Balance Subtotal:	<u>132,351.33</u>	<u>4,544.42</u>	<u>136,895.75</u>
Total Liabilities, Deferred Inflows of Resources, and Fund Equity:		<u>132,351.33</u>	<u>4,544.42</u>	<u>136,895.75</u>

- 38,000
98,895.75

Batch Description:	FEBRUARY 2021, ACTIVITY FUND INVOICES	Processing Month:	02/2021	Credit Card Vendor ID:	End of Fiscal Year Expense Invoices:
Vendor ID: AMAZON	AMAZON	PO Number:	Invoice Number: 21221	Amount:	35.99
Description:		Invoice Date: 01/14/2021	Due Date: 02/24/2021	Status: PP	1099 Amount: 0.00
Sequence: 1	Check Type: Check	Checking Account ID: 5	Check Number: 12197	Check Date: 02/12/2021	
<u>Chart of Account Number</u>	<u>Detail Description</u>	<u>Cost Center ID</u>	<u>Detail Amount</u>	<u>1099 Detail Amount</u>	<u>Asset/Asset Tag</u>
05 3200 610 000 4020 0 000	WALL MONEY BOX		35.99	N	In Full
Vendor ID: ANDEL	ANDEL, KEVIN	PO Number:	Invoice Number: 2521	Amount:	130.00
Description:		Invoice Date: 02/01/2021	Due Date: 02/05/2021	Status: PP	1099 Amount: 130.00
Sequence: 1	Check Type: Check	Checking Account ID: 5	Check Number: 12159	Check Date: 02/05/2021	
<u>Chart of Account Number</u>	<u>Detail Description</u>	<u>Cost Center ID</u>	<u>Detail Amount</u>	<u>1099 Detail Amount</u>	<u>Asset/Asset Tag</u>
05 3200 150 000 4015 0 000	VARSITY BOYS/GIRLS BBALL OFFICIALS		130.00	N	In Full
Vendor ID: APPLEBYK	APPLEBY, KELSEY	PO Number:	Invoice Number: 22521	Amount:	86.06
Description:		Invoice Date: 02/25/2021	Due Date: 02/26/2021	Status: PP	1099 Amount: 86.06
Sequence: 1	Check Type: Check	Checking Account ID: 5	Check Number: 12215	Check Date: 02/25/2021	
<u>Chart of Account Number</u>	<u>Detail Description</u>	<u>Cost Center ID</u>	<u>Detail Amount</u>	<u>1099 Detail Amount</u>	<u>Asset/Asset Tag</u>
05 3200 610 000 4016 0 000	NSAA SUB STATE VARSITY GIRLS BBALL OFFIC		86.06	N	In Full
Vendor ID: BAKERSCAND	BAKERS CANDIES INC.	PO Number:	Invoice Number: 35395	Amount:	250.00
Description:		Invoice Date: 02/09/2021	Due Date: 02/28/2021	Status: PP	1099 Amount: 0.00
Sequence: 1	Check Type: Check	Checking Account ID: 5	Check Number: 12214	Check Date: 02/18/2021	
<u>Chart of Account Number</u>	<u>Detail Description</u>	<u>Cost Center ID</u>	<u>Detail Amount</u>	<u>1099 Detail Amount</u>	<u>Asset/Asset Tag</u>
05 3200 610 000 4220 0 000	CHOCOLATE VALENTINES DAY FUNDRAISER		250.00	N	In Full
Vendor ID: BAUERSCARR	BAUERS, CARRIE	PO Number:	Invoice Number: 2921	Amount:	30.00
Description:		Invoice Date: 02/06/2021	Due Date: 02/06/2021	Status: PP	1099 Amount: 0.00
Sequence: 1	Check Type: Check	Checking Account ID: 5	Check Number: 12182	Check Date: 02/09/2021	
<u>Chart of Account Number</u>	<u>Detail Description</u>	<u>Cost Center ID</u>	<u>Detail Amount</u>	<u>1099 Detail Amount</u>	<u>Asset/Asset Tag</u>
05 3200 150 000 4017 0 000	SUB DISTRICT WRESTLING GATE		30.00	N	In Full
Vendor ID: BEATRICE	BEATRICE PUBLIC SCHOOL	PO Number:	Invoice Number: 20521	Amount:	58.00
Description:		Invoice Date: 02/05/2021	Due Date: 02/06/2021	Status: PP	1099 Amount: 0.00
Sequence: 1	Check Type: Check	Checking Account ID: 5	Check Number: 12171	Check Date: 02/05/2021	
<u>Chart of Account Number</u>	<u>Detail Description</u>	<u>Cost Center ID</u>	<u>Detail Amount</u>	<u>1099 Detail Amount</u>	<u>Asset/Asset Tag</u>
05 3200 890 000 4190 0 000	THE BIG O SPEECH MEET ENTRY FEE		58.00	N	In Full
Vendor ID: BEATRICE	BEATRICE PUBLIC SCHOOL	PO Number:	Invoice Number: 21821	Amount:	167.00
Description:		Invoice Date: 02/11/2021	Due Date: 02/12/2021	Status: PP	1099 Amount: 0.00
Sequence: 1	Check Type: Check	Checking Account ID: 5	Check Number: 12206	Check Date: 02/18/2021	
<u>Chart of Account Number</u>	<u>Detail Description</u>	<u>Cost Center ID</u>	<u>Detail Amount</u>	<u>1099 Detail Amount</u>	<u>Asset/Asset Tag</u>
05 3200 890 000 4190 0 000	BEATRICE SPEECH INVITE		167.00	N	In Full

Vendor ID: BOBOLZCODY BOBOLZ, CODY

Description: PO Number: Invoice Number: 2921 Amount: 50.00
Sequence: 1 Check Type: Check Invoice Date: 02/06/2021 Due Date: 02/06/2021 Status: PP 1099 Amount: 0.00
Chart of Account Number: Detail Description Check Number: 12184 Check Date: 02/09/2021
05 3200 150 000 4017 0 000 WRESTLING SUB DISTRICTS In Full
ANNOUNCING 50.00 N
Detail Amount 1099 Detail Amount Asset/Asset Tag

Vendor ID: CEDER CEDER, ERIC

Description: PO Number: Invoice Number: 2921 Amount: 135.00
Sequence: 1 Check Type: Check Invoice Date: 02/09/2021 Due Date: 02/12/2021 Status: PP 1099 Amount: 135.00
Chart of Account Number: Detail Description Check Number: 12187 Check Date: 02/09/2021
05 3200 150 000 4015 0 000 VARSITY GIRLS/BOYS BBALL OFFICIALS In Full
135.00 N
Detail Amount 1099 Detail Amount Asset/Asset Tag

Vendor ID: CHERRY CHERRY, CHASE

Description: PO Number: Invoice Number: 21821 Amount: 70.00
Sequence: 1 Check Type: Check Invoice Date: 02/11/2021 Due Date: 02/12/2021 Status: PP 1099 Amount: 0.00
Chart of Account Number: Detail Description Check Number: 12208 Check Date: 02/18/2021
05 3200 890 000 4190 0 000 JUDGE AT HUMPHREY INVITE In Full
70.00 N
Detail Amount 1099 Detail Amount Asset/Asset Tag

Vendor ID: CHERRY CHERRY, CHASE

Description: PO Number: Invoice Number: 2221 Amount: 70.00
Sequence: 1 Check Type: Check Invoice Date: 02/01/2021 Due Date: 02/01/2021 Status: PP 1099 Amount: 0.00
Chart of Account Number: Detail Description Check Number: 12155 Check Date: 02/02/2021
05 3200 890 000 4190 0 000 NON CERTIFIED JUDGE SPEECH MEET In Full
70.00 N
Detail Amount 1099 Detail Amount Asset/Asset Tag

Vendor ID: COOLEYSTEV COOLEY, STEVEN

Description: PO Number: Invoice Number: 2521 Amount: 268.00
Sequence: 1 Check Type: Check Invoice Date: 02/01/2021 Due Date: 02/06/2021 Status: PP 1099 Amount: 268.00
Chart of Account Number: Detail Description Check Number: 12167 Check Date: 02/05/2021
05 3200 150 000 4017 0 000 WRESTLING SUB DISTRICTS OFFICIAL In Full
268.00 N
Detail Amount 1099 Detail Amount Asset/Asset Tag

Vendor ID: COOPERT COOPER, TAYLOR

Description: PO Number: Invoice Number: 020221 Amount: 80.00
Sequence: 1 Check Type: Check Invoice Date: 02/01/2021 Due Date: 02/02/2021 Status: PP 1099 Amount: 80.00
Chart of Account Number: Detail Description Check Number: 12153 Check Date: 02/02/2021
05 3200 890 000 4190 0 000 CERTIFIED SPEECH JUDGE In Full
80.00 N
Detail Amount 1099 Detail Amount Asset/Asset Tag

Vendor ID: COOPERT COOPER, TAYLOR

Description: PO Number: Invoice Number: 20521 Amount: 80.00
Sequence: 1 Check Type: Check Invoice Date: 02/01/2021 Due Date: 02/05/2021 Status: PP 1099 Amount: 80.00
Chart of Account Number: Detail Description Check Number: 12170 Check Date: 02/05/2021
05 3200 890 000 4190 0 000 CERTIFIED SPEECH JUDGE In Full
80.00 N
Detail Amount 1099 Detail Amount Asset/Asset Tag

Vendor ID: COOPERT COOPER, TAYLOR

Description: PO Number: Invoice Number: 22521 Amount: 80.00
Sequence: 1 Check Type: Check Invoice Date: 02/25/2021 Due Date: 02/27/2021 Status: PP 1099 Amount: 80.00
Chart of Account Number: Detail Description Check Number: 12170 Check Date: 02/05/2021
05 3200 890 000 4190 0 000 CERTIFIED SPEECH JUDGE In Full
80.00 N
Detail Amount 1099 Detail Amount Asset/Asset Tag

Invoice Listing - Detail

Sequence: 1	Check Type: Check	Checking Account ID: 5	Check Number: 12227	Check Date: 02/25/2021	Amount:
<u>Chart of Account Number</u>	<u>Detail Description</u>	<u>Cost Center ID</u>	<u>Detail Amount</u>	<u>1099 Detail Amount</u>	<u>Asset/Asset Tag</u>
05 3200 890 000 4190 0 000	CERTIFIED JUDGE MCCOOL INVITE		80.00 N	80.00 N	In Full
Vendor ID: CRC	CROSSROADS CONFERENCE	PO Number:	Invoice Number: 2921	Amount:	1,323.48
Description:		Invoice Date: 02/08/2021	Due Date: 02/08/2021	Status: PP	1099 Amount: 0.00
Sequence: 1	Check Type: Check	Checking Account ID: 5	Check Number: 12174	Check Date: 02/09/2021	
<u>Chart of Account Number</u>	<u>Detail Description</u>	<u>Cost Center ID</u>	<u>Detail Amount</u>	<u>1099 Detail Amount</u>	<u>Asset/Asset Tag</u>
05 3200 890 000 4015 0 000	CRC BASKETBALL GATE MONEY		1,323.48 N		In Full
Vendor ID: CUBBY'S	CUBBY'S	PO Number:	Invoice Number: 21221	Amount:	29.05
Description:		Invoice Date: 01/14/2021	Due Date: 02/24/2021	Status: PP	1099 Amount: 0.00
Sequence: 1	Check Type: Check	Checking Account ID: 5	Check Number: 12200	Check Date: 02/12/2021	
<u>Chart of Account Number</u>	<u>Detail Description</u>	<u>Cost Center ID</u>	<u>Detail Amount</u>	<u>1099 Detail Amount</u>	<u>Asset/Asset Tag</u>
05 3200 610 000 4017 0 100	WATER AND ICE FOR WRESTLING MEET		11.38 N		In Full
05 3200 610 000 4010 0 000	ICE AND WATER FOR REFFS		17.67 N		
Vendor ID: CURTISWILL	CURTIS, WILL	PO Number:	Invoice Number: 21221	Amount:	70.00
Description:		Invoice Date: 02/11/2021	Due Date: 02/12/2021	Status: PP	1099 Amount: 70.00
Sequence: 1	Check Type: Check	Checking Account ID: 5	Check Number: 12192	Check Date: 02/12/2021	
<u>Chart of Account Number</u>	<u>Detail Description</u>	<u>Cost Center ID</u>	<u>Detail Amount</u>	<u>1099 Detail Amount</u>	<u>Asset/Asset Tag</u>
05 3200 150 000 4015 0 000	JV BOYS BBALL OFFICIALS		70.00 N		In Full
Vendor ID: CURTISWILL	CURTIS, WILL	PO Number:	Invoice Number: 2521	Amount:	70.00
Description:		Invoice Date: 02/01/2021	Due Date: 02/05/2021	Status: PP	1099 Amount: 70.00
Sequence: 1	Check Type: Check	Checking Account ID: 5	Check Number: 12164	Check Date: 02/05/2021	
<u>Chart of Account Number</u>	<u>Detail Description</u>	<u>Cost Center ID</u>	<u>Detail Amount</u>	<u>1099 Detail Amount</u>	<u>Asset/Asset Tag</u>
05 3200 150 000 4016 0 000	JV GIRLS/BOYS BBALL OFFICIALS		70.00 N		In Full
Vendor ID: CYZAMARK	CYZA, MARK	PO Number:	Invoice Number: 22520	Amount:	30.00
Description:		Invoice Date: 02/24/2021	Due Date: 02/26/2021	Status: PP	1099 Amount: 0.00
Sequence: 1	Check Type: Check	Checking Account ID: 5	Check Number: 12222	Check Date: 02/25/2021	
<u>Chart of Account Number</u>	<u>Detail Description</u>	<u>Cost Center ID</u>	<u>Detail Amount</u>	<u>1099 Detail Amount</u>	<u>Asset/Asset Tag</u>
05 3200 150 000 4016 0 000	NSAA SUB-STATE ANNOUNCER		30.00 N		In Full
Vendor ID: FIELDSK	FIELDS, KEVIN	PO Number:	Invoice Number: 20521	Amount:	130.00
Description:		Invoice Date: 02/01/2021	Due Date: 02/05/2021	Status: PP	1099 Amount: 130.00
Sequence: 1	Check Type: Check	Checking Account ID: 5	Check Number: 12160	Check Date: 02/05/2021	
<u>Chart of Account Number</u>	<u>Detail Description</u>	<u>Cost Center ID</u>	<u>Detail Amount</u>	<u>1099 Detail Amount</u>	<u>Asset/Asset Tag</u>
05 3200 150 000 4016 0 000	VARSITY GIRLS/BOYS BBALL OFFICIALS		130.00 N		In Full
Vendor ID: TGLOCK	GLOCK, TED	PO Number:	Invoice Number: 22521	Amount:	30.00
Description:		Invoice Date: 02/24/2021	Due Date: 02/26/2021	Status: PP	1099 Amount: 0.00
Sequence: 1	Check Type: Check	Checking Account ID: 5	Check Number: 12221	Check Date: 02/25/2021	
<u>Chart of Account Number</u>	<u>Detail Description</u>	<u>Cost Center ID</u>	<u>Detail Amount</u>	<u>1099 Detail Amount</u>	<u>Asset/Asset Tag</u>
05 3200 150 000 4016 0 000	VARSITY GIRLS/BOYS BBALL OFFICIALS		130.00 N		In Full

Vendor ID: JENSESARA	JENSEN, SARA	PO Number:	Invoice Number: 22521	Amount:	246.21
Description:		Invoice Date: 02/19/2021	Due Date: 02/28/2021	Status: PP	1099 Amount: 0.00
Sequence: 1	Check Type: Check	Checking Account ID: 5	Check Number: 12231	Check Date: 02/25/2021	
<u>Chart of Account Number</u>	<u>Detail Description</u>	<u>Cost Center ID</u>	<u>Detail Amount</u>	<u>1099 Detail Amount</u>	<u>Asset/Asset Tag</u>
05 3200 610 000 4220 0 000	SUPPLIES FOR VALENTINES FUNDRAISER		246.21	N	
Vendor ID: JOHNSONALE	JOHNSON, ALEX	PO Number:	Invoice Number: 22521	Amount:	86.06
Description:		Invoice Date: 02/24/2021	Due Date: 02/26/2021	Status: PP	1099 Amount: 86.06
Sequence: 1	Check Type: Check	Checking Account ID: 5	Check Number: 12216	Check Date: 02/25/2021	
<u>Chart of Account Number</u>	<u>Detail Description</u>	<u>Cost Center ID</u>	<u>Detail Amount</u>	<u>1099 Detail Amount</u>	<u>Asset/Asset Tag</u>
05 3200 150 000 4016 0 000	NSAA SUB STATE GIRLS BBALL OFFICIALS		86.06	N	
Vendor ID: KEMPERT	KEMPER, TAYLOR	PO Number:	Invoice Number: 20921	Amount:	30.00
Description:		Invoice Date: 02/05/2021	Due Date: 02/06/2021	Status: PP	1099 Amount: 0.00
Sequence: 1	Check Type: Check	Checking Account ID: 5	Check Number: 12183	Check Date: 02/09/2021	
<u>Chart of Account Number</u>	<u>Detail Description</u>	<u>Cost Center ID</u>	<u>Detail Amount</u>	<u>1099 Detail Amount</u>	<u>Asset/Asset Tag</u>
05 3200 150 000 4017 0 000	SUB DISTRICT WRESTLING		30.00	N	
Vendor ID: KOONTZ	KOONTZ, JOANN	PO Number:	Invoice Number: 20221	Amount:	80.00
Description:		Invoice Date: 02/01/2021	Due Date: 02/01/2021	Status: PP	1099 Amount: 80.00
Sequence: 1	Check Type: Check	Checking Account ID: 5	Check Number: 12152	Check Date: 02/02/2021	
<u>Chart of Account Number</u>	<u>Detail Description</u>	<u>Cost Center ID</u>	<u>Detail Amount</u>	<u>1099 Detail Amount</u>	<u>Asset/Asset Tag</u>
05 3200 890 000 4190 0 000	CERTIFIED SPEECH JUDGE		80.00	N	
Vendor ID: KRATOCHVIL	KRATOCHVIL, RYAN	PO Number:	Invoice Number: 2521	Amount:	257.00
Description:		Invoice Date: 02/02/2021	Due Date: 02/06/2021	Status: PP	1099 Amount: 257.00
Sequence: 1	Check Type: Check	Checking Account ID: 5	Check Number: 12166	Check Date: 02/05/2021	
<u>Chart of Account Number</u>	<u>Detail Description</u>	<u>Cost Center ID</u>	<u>Detail Amount</u>	<u>1099 Detail Amount</u>	<u>Asset/Asset Tag</u>
05 3200 150 000 4017 0 000	VARSITY WRESTLING SUB DISTRICTS OFFICIAL		257.00	N	
Vendor ID: LINDSLEYE	LINDSLEY, ERIC	PO Number:	Invoice Number: 20921	Amount:	30.00
Description:		Invoice Date: 02/05/2021	Due Date: 02/06/2021	Status: PP	1099 Amount: 0.00
Sequence: 1	Check Type: Check	Checking Account ID: 5	Check Number: 12179	Check Date: 02/09/2021	
<u>Chart of Account Number</u>	<u>Detail Description</u>	<u>Cost Center ID</u>	<u>Detail Amount</u>	<u>1099 Detail Amount</u>	<u>Asset/Asset Tag</u>
05 3200 150 000 4017 0 000	SUB DISTRICT WRESTLING		30.00	N	
Vendor ID: LINDSLEYE	LINDSLEY, ERIC	PO Number:	Invoice Number: 2921	Amount:	30.00
Description:		Invoice Date: 02/08/2021	Due Date: 02/09/2021	Status: PP	1099 Amount: 0.00
Sequence: 1	Check Type: Check	Checking Account ID: 5	Check Number: 12176	Check Date: 02/09/2021	
<u>Chart of Account Number</u>	<u>Detail Description</u>	<u>Cost Center ID</u>	<u>Detail Amount</u>	<u>1099 Detail Amount</u>	<u>Asset/Asset Tag</u>
05 3200 150 000 4017 0 000	TRACK WRESTLING		30.00	N	
Vendor ID: LINDSLEYH	LINDSLEY, HEATHER	PO Number:	Invoice Number: 120921	Amount:	30.00
Description:		Invoice Date: 02/05/2021	Due Date: 02/06/2021	Status: PP	1099 Amount: 0.00

Invoice Listing - Detail

Sequence: 1	Check Type: Check	Checking Account ID: 5	Check Number: 12178	Check Date: 02/09/2021	Amount: 30.00
<u>Chart of Account Number</u>	<u>Detail Description</u>	<u>Cost Center ID</u>	<u>Detail Amount</u>	<u>1099 Detail Amount</u>	<u>Asset/Asset Tag</u>
05 3200 150 000 4017 0 000	TRACK WRESTLING		30.00		N
Vendor ID: LINDSLEYH	LINDSLEY, HEATHER	PO Number:	Invoice Number: 2921	Amount:	30.00
Description:		Invoice Date: 02/08/2021	Due Date: 02/09/2021	Status: PP	1099 Amount: 0.00
Sequence: 1	Check Type: Check	Checking Account ID: 5	Check Number: 12177	Check Date: 02/09/2021	Amount: 30.00
<u>Chart of Account Number</u>	<u>Detail Description</u>	<u>Cost Center ID</u>	<u>Detail Amount</u>	<u>1099 Detail Amount</u>	<u>Asset/Asset Tag</u>
05 3200 150 000 4017 0 000	TRACK WRESTLING		30.00		N
Vendor ID: LOGANVIEW	LOGAN VIEW PUBLIC SCHOOLS,	PO Number:	Invoice Number: 2221	Amount:	272.00
Description:		Invoice Date: 02/01/2021	Due Date: 02/02/2021	Status: PP	1099 Amount: 0.00
Sequence: 1	Check Type: Check	Checking Account ID: 5	Check Number: 12151	Check Date: 02/02/2021	Amount: 272.00
<u>Chart of Account Number</u>	<u>Detail Description</u>	<u>Cost Center ID</u>	<u>Detail Amount</u>	<u>1099 Detail Amount</u>	<u>Asset/Asset Tag</u>
05 3200 890 000 4190 0 000	LOGANVIEW SPEECH MEET ENTRY FEE		272.00		N
Vendor ID: MAKEYCASEY	MAKEY, CASEY	PO Number:	Invoice Number: 21821	Amount:	135.00
Description:		Invoice Date: 02/18/2021	Due Date: 02/19/2021	Status: PP	1099 Amount: 0.00
Sequence: 1	Check Type: Check	Checking Account ID: 5	Check Number: 12201	Check Date: 02/18/2021	Amount: 135.00
<u>Chart of Account Number</u>	<u>Detail Description</u>	<u>Cost Center ID</u>	<u>Detail Amount</u>	<u>1099 Detail Amount</u>	<u>Asset/Asset Tag</u>
05 3200 150 000 4015 0 000	J/VVARSITY BOYS BBALL OFFICIALS		135.00		N
Vendor ID: MCCOOLJUNC	MCCOOL JUNCTION HIGH SCHOOL	PO Number:	Invoice Number: 22521	Amount:	252.00
Description:		Invoice Date: 02/25/2021	Due Date: 02/27/2021	Status: PP	1099 Amount: 0.00
Sequence: 1	Check Type: Check	Checking Account ID: 5	Check Number: 12223	Check Date: 02/25/2021	Amount: 252.00
<u>Chart of Account Number</u>	<u>Detail Description</u>	<u>Cost Center ID</u>	<u>Detail Amount</u>	<u>1099 Detail Amount</u>	<u>Asset/Asset Tag</u>
05 3200 890 000 4190 0 000	SPEECH MEET ENTRY FEE		252.00		N
Vendor ID: MILLERSCOT	MILLER, SCOTT	PO Number:	Invoice Number: 21821	Amount:	135.00
Description:		Invoice Date: 02/18/2021	Due Date: 02/19/2021	Status: PP	1099 Amount: 135.00
Sequence: 1	Check Type: Check	Checking Account ID: 5	Check Number: 12203	Check Date: 02/18/2021	Amount: 135.00
<u>Chart of Account Number</u>	<u>Detail Description</u>	<u>Cost Center ID</u>	<u>Detail Amount</u>	<u>1099 Detail Amount</u>	<u>Asset/Asset Tag</u>
05 3200 150 000 4015 0 000	J/VVARSITY BOYS BBALL OFFICIALS		135.00	135.00	N
Vendor ID: NSAA	NE SCHOOL ACTIVITY ASSOCIATION	PO Number:	Invoice Number: 2921	Amount:	485.55
Description:		Invoice Date: 02/01/2021	Due Date: 02/08/2021	Status: PP	1099 Amount: 0.00
Sequence: 1	Check Type: Check	Checking Account ID: 5	Check Number: 12173	Check Date: 02/09/2021	Amount: 485.55
<u>Chart of Account Number</u>	<u>Detail Description</u>	<u>Cost Center ID</u>	<u>Detail Amount</u>	<u>1099 Detail Amount</u>	<u>Asset/Asset Tag</u>
05 3200 890 000 4017 0 000	NSAA SUB DISTRICTS		485.55		N
Vendor ID: NEFBLA	NEBRASKA FBLA	PO Number:	Invoice Number: 23436	Amount:	160.00
Description:		Invoice Date: 02/18/2021	Due Date: 02/25/2021	Status: PP	1099 Amount: 0.00
Sequence: 1	Check Type: Check	Checking Account ID: 5	Check Number: 12230	Check Date: 02/25/2021	Amount: 160.00
<u>Chart of Account Number</u>	<u>Detail Description</u>	<u>Cost Center ID</u>	<u>Detail Amount</u>	<u>1099 Detail Amount</u>	<u>Asset/Asset Tag</u>
05 3200 890 000 4220 0 000	SLC REGISTRATION		160.00		N

Vendor ID: NEKLALISON	NEKL, ALISON	PO Number:	Invoice Number: 20221	Amount:	250.00
Description:		Invoice Date: 02/01/2021	Due Date: 02/02/2021	Status: PP	1099 Amount: 0.00
Sequence: 1	Check Type: Check	Checking Account ID:	Check Number: 12157	Check Date: 02/02/2021	
<u>Chart of Account Number</u>	<u>Detail Description</u>	<u>Cost Center ID</u>	<u>Detail Amount</u>	<u>1099 Detail Amount</u>	<u>Asset/Asset Tag</u>
05 3200 610 000 4030 0 000	NHS SCHOLARSHIP		250.00	N	In Full
Vendor ID: OFFTHEWALL	OFF THE WALL GRAPHICS & PRINTING	PO Number:	Invoice Number: 21821	Amount:	569.50
Description:		Invoice Date: 02/03/2021	Due Date: 02/23/2021	Status: PP	1099 Amount: 0.00
Sequence: 1	Check Type: Check	Checking Account ID:	Check Number: 12213	Check Date: 02/18/2021	
<u>Chart of Account Number</u>	<u>Detail Description</u>	<u>Cost Center ID</u>	<u>Detail Amount</u>	<u>1099 Detail Amount</u>	<u>Asset/Asset Tag</u>
05 3200 610 000 4130 0 000	T-SHIRTS DANCE CAMP		569.50	N	In Full
Vendor ID: PAVICH	PAVICH, JUSTIN	PO Number:	Invoice Number: 22521	Amount:	86.06
Description:		Invoice Date: 02/25/2021	Due Date: 02/26/2021	Status: PP	1099 Amount: 86.06
Sequence: 1	Check Type: Check	Checking Account ID:	Check Number: 12217	Check Date: 02/25/2021	
<u>Chart of Account Number</u>	<u>Detail Description</u>	<u>Cost Center ID</u>	<u>Detail Amount</u>	<u>1099 Detail Amount</u>	<u>Asset/Asset Tag</u>
05 3200 610 000 4014 0 000	NSAA SUB STATE GIRLS BBALL OFFICIALS		86.06	N	In Full
Vendor ID: PEPSI	PEPSI COLA CO.	PO Number:	Invoice Number: 24874005	Amount:	454.58
Description:		Invoice Date: 02/11/2021	Due Date: 03/15/2021	Status: PP	1099 Amount: 0.00
Sequence: 1	Check Type: Check	Checking Account ID:	Check Number: 12233	Check Date: 02/25/2021	
<u>Chart of Account Number</u>	<u>Detail Description</u>	<u>Cost Center ID</u>	<u>Detail Amount</u>	<u>1099 Detail Amount</u>	<u>Asset/Asset Tag</u>
05 3200 610 000 4020 0 000	PEPSI PRODUCTS		454.58	N	In Full
Vendor ID: PINNAC	PINNACLE BANK-SHELBY	PO Number:	Invoice Number: 21221	Amount:	217.80
Description:		Invoice Date: 01/17/2021	Due Date: 02/28/2021	Status: PP	1099 Amount: 0.00
Sequence: 1	Check Type: Check	Checking Account ID:	Check Number: 12194	Check Date: 02/12/2021	
<u>Chart of Account Number</u>	<u>Detail Description</u>	<u>Cost Center ID</u>	<u>Detail Amount</u>	<u>1099 Detail Amount</u>	<u>Asset/Asset Tag</u>
05 3200 610 000 4020 0 000	TORTILLA CHIPS AND CHEESE		217.80	N	In Full
Vendor ID: POTTERTAYL	POTTER, TAYLOR	PO Number:	Invoice Number: 22521	Amount:	70.00
Description:		Invoice Date: 02/25/2021	Due Date: 02/27/2021	Status: PP	1099 Amount: 70.00
Sequence: 1	Check Type: Check	Checking Account ID:	Check Number: 12225	Check Date: 02/25/2021	
<u>Chart of Account Number</u>	<u>Detail Description</u>	<u>Cost Center ID</u>	<u>Detail Amount</u>	<u>1099 Detail Amount</u>	<u>Asset/Asset Tag</u>
05 3200 890 000 4190 0 000	SPEECH JUDGE		70.00	N	In Full
Vendor ID: RCPITSTOP	RC PIT STOP	PO Number:	Invoice Number: 805532	Amount:	174.00
Description:		Invoice Date: 01/31/2021	Due Date: 02/26/2021	Status: PP	1099 Amount: 0.00
Sequence: 1	Check Type: Check	Checking Account ID:	Check Number: 12199	Check Date: 02/12/2021	
<u>Chart of Account Number</u>	<u>Detail Description</u>	<u>Cost Center ID</u>	<u>Detail Amount</u>	<u>1099 Detail Amount</u>	<u>Asset/Asset Tag</u>
05 3200 610 000 4010 0 000	CRC BASKETBALL HOSPITALITY ROOM		174.00	N	In Full
Vendor ID: RICHARDSON	RICHARDSON, HUNTER	PO Number:	Invoice Number: 2521	Amount:	70.00
Description:		Invoice Date: 02/01/2021	Due Date: 02/05/2021	Status: PP	1099 Amount: 70.00
Sequence: 1	Check Type: Check	Checking Account ID:	Check Number: 12162	Check Date: 02/05/2021	

Chart of Account Number
05 3200 150 000 4015 0 000

Detail Description
JV GIRLS/BOYS BASKETBALL OFFICIALS

Cost Center ID
70.00

Detail Amount
70.00 N

1099 Detail Amount Asset/Asset Tag
70.00 N

Vendor ID: SCHULTETOM SCHULTE, TOM **Invoice Number: 2521** **Amount: 70.00**

Description:
Sequence: 1 Check Type: Check Checking Account ID:
Chart of Account Number
05 3200 150 000 4015 0 000

Invoice Date: 02/01/2021 Due Date: 02/05/2021 Status: PP 1099 Amount: 70.00
Check Number: 12161 Check Date: 02/05/2021
Detail Description
JV GIRLS/BOYS BBALL OFFICIALS

Detail Amount
70.00 N

1099 Detail Amount Asset/Asset Tag
70.00 N

Vendor ID: SCHUYLERHI SCHUYLER HIGH SCHOOL **Invoice Number: 20521** **Amount: 280.00**

Description:
Sequence: 1 Check Type: Check Checking Account ID:
Chart of Account Number
05 3200 890 000 4190 0 000

Invoice Date: 02/01/2021 Due Date: 02/05/2021 Status: PP 1099 Amount: 0.00
Check Number: 12169 Check Date: 02/05/2021
Detail Description
SCHUYLER SPEECH INVITE FEE

Detail Amount
280.00 N

1099 Detail Amount Asset/Asset Tag
N

Vendor ID: SCOTUS SCOTUS CENTRAL CATHOLIC SCHOOL **Invoice Number: 20221** **Amount: 168.00**

Description:
Sequence: 1 Check Type: Check Checking Account ID:
Chart of Account Number
05 3200 890 000 4190 0 000

Invoice Date: 02/01/2021 Due Date: 02/02/2021 Status: PP 1099 Amount: 0.00
Check Number: 12154 Check Date: 02/02/2021
Detail Description
SPEECH MEET FEE

Detail Amount
168.00 N

1099 Detail Amount Asset/Asset Tag
0.00 N

Vendor ID: SHELBYLUM SHELBY LUMBER CO. **Invoice Number: 109037** **Amount: 124.35**

Description:
Sequence: 1 Check Type: Check Checking Account ID:
Chart of Account Number
05 3200 610 000 4160 0 000

Invoice Date: 01/09/2021 Due Date: 02/26/2021 Status: PP 1099 Amount: 0.00
Check Number: 12193 Check Date: 02/12/2021
Detail Description
WOOD

Detail Amount
124.35 N

1099 Detail Amount Asset/Asset Tag
N

Vendor ID: SHENKDYLAN SHENK, DYLAN **Invoice Number: 21821** **Amount: 135.00**

Description:
Sequence: 1 Check Type: Check Checking Account ID:
Chart of Account Number
05 3200 150 000 4011 0 000

Invoice Date: 02/18/2021 Due Date: 02/19/2021 Status: PP 1099 Amount: 135.00
Check Number: 12202 Check Date: 02/18/2021
Detail Description
JV/VARSITY BOYS BASKETBALL OFFICIALS

Detail Amount
135.00 N

1099 Detail Amount Asset/Asset Tag
135.00 N

Vendor ID: SHERER SHERER, CHARLES **Invoice Number: 2521** **Amount: 206.00**

Description:
Sequence: 1 Check Type: Check Checking Account ID:
Chart of Account Number
05 3200 150 000 4017 0 000

Invoice Date: 02/01/2021 Due Date: 02/06/2021 Status: PP 1099 Amount: 206.00
Check Number: 12165 Check Date: 02/05/2021
Detail Description
VARSITY WRESTLING SUB DISTRICT OFFICIALS

Detail Amount
206.00 N

1099 Detail Amount Asset/Asset Tag
206.00 N

Vendor ID: SLOUPMIKE SLOUP, MIKE **Invoice Number: 2521** **Amount: 200.00**

Description:
Sequence: 1 Check Type: Check Checking Account ID:
Chart of Account Number
05 3200 150 000 4017 0 000

Invoice Date: 02/01/2021 Due Date: 02/06/2021 Status: PP 1099 Amount: 0.00
Check Number: 12172 Check Date: 02/05/2021
Detail Description
VARSITY WRESTLING SUB DISTRICT

Detail Amount
200.00 N

1099 Detail Amount Asset/Asset Tag
N

TRAINER

Vendor ID: SPERLING	SPERLING, DARIN	PO Number:	Invoice Number: 20521	Amount:	130.00
Description:		Invoice Date: 02/01/2021	Due Date: 02/05/2021	Status: PP	1099 Amount: 0.00
Sequence: 1	Check Type: Check	Checking Account ID:	Check Number: 12158	Check Date: 02/05/2021	
<u>Chart of Account Number</u>	<u>Detail Description</u>	<u>Cost Center ID</u>	<u>Detail Amount</u>	<u>1099 Detail Amount</u>	<u>Asset/Asset Tag</u>
05 3200 150 000 4016 0 000	VARSITY GIRLS/BOYS BBALL OFFICIALS		130.00	N	In Full
Vendor ID: STJOSE	ST. JOSEPH'S ATHLETIC CLUB	PO Number:	Invoice Number: 21821	Amount:	135.00
Description:		Invoice Date: 02/01/2021	Due Date: 02/28/2021	Status: PP	1099 Amount: 0.00
Sequence: 1	Check Type: Check	Checking Account ID:	Check Number: 12212	Check Date: 02/18/2021	
<u>Chart of Account Number</u>	<u>Detail Description</u>	<u>Cost Center ID</u>	<u>Detail Amount</u>	<u>1099 Detail Amount</u>	<u>Asset/Asset Tag</u>
05 3200 610 000 4010 0 000	CRC AD		135.00	N	In Full
Vendor ID: STEVESTAWA	STEWART, STEVEN	PO Number:	Invoice Number: 20921	Amount:	50.00
Description:		Invoice Date: 02/06/2021	Due Date: 02/06/2021	Status: PP	1099 Amount: 0.00
Sequence: 1	Check Type: Check	Checking Account ID:	Check Number: 12186	Check Date: 02/09/2021	
<u>Chart of Account Number</u>	<u>Detail Description</u>	<u>Cost Center ID</u>	<u>Detail Amount</u>	<u>1099 Detail Amount</u>	<u>Asset/Asset Tag</u>
05 3200 150 000 4017 0 000	MAINTENANCE FOR SUB DISTRICT WRESTLING		50.00	N	In Full
Vendor ID: TROFHOLTZU	TROFHOLZ, TURNER	PO Number:	Invoice Number: 21821	Amount:	60.00
Description:		Invoice Date: 02/15/2021	Due Date: 02/16/2021	Status: PP	1099 Amount: 0.00
Sequence: 1	Check Type: Check	Checking Account ID:	Check Number: 12205	Check Date: 02/18/2021	
<u>Chart of Account Number</u>	<u>Detail Description</u>	<u>Cost Center ID</u>	<u>Detail Amount</u>	<u>1099 Detail Amount</u>	<u>Asset/Asset Tag</u>
05 3200 610 000 4010 0 000	SENIOR NIGHT ROSES ALL SPORTS		60.00	N	In Full
Vendor ID: TROFHOLTZU	TROFHOLZ, TURNER	PO Number:	Invoice Number: 22521	Amount:	50.00
Description:		Invoice Date: 02/24/2021	Due Date: 02/26/2021	Status: PP	1099 Amount: 0.00
Sequence: 1	Check Type: Check	Checking Account ID:	Check Number: 12218	Check Date: 02/25/2021	
<u>Chart of Account Number</u>	<u>Detail Description</u>	<u>Cost Center ID</u>	<u>Detail Amount</u>	<u>1099 Detail Amount</u>	<u>Asset/Asset Tag</u>
05 3200 150 000 4016 0 000	NSAA SUB STATE GIRLS BBALL RUNNING EVENT		50.00	N	In Full
Vendor ID: TROFHOLTZU	TROFHOLZ, TURNER	PO Number:	Invoice Number: 2921	Amount:	50.00
Description:		Invoice Date: 02/01/2021	Due Date: 02/06/2021	Status: PP	1099 Amount: 0.00
Sequence: 1	Check Type: Check	Checking Account ID:	Check Number: 12185	Check Date: 02/09/2021	
<u>Chart of Account Number</u>	<u>Detail Description</u>	<u>Cost Center ID</u>	<u>Detail Amount</u>	<u>1099 Detail Amount</u>	<u>Asset/Asset Tag</u>
05 3200 150 000 4017 0 000	SUB DISTRICTS WRESTLING HOST EVENT		50.00	N	In Full
Vendor ID: VALENTINO	VALENTINO'S	PO Number:	Invoice Number: 1782, 1778	Amount:	224.00
Description:		Invoice Date: 01/21/2021	Due Date: 02/11/2021	Status: PP	1099 Amount: 0.00
Sequence: 1	Check Type: Check	Checking Account ID:	Check Number: 12190	Check Date: 02/09/2021	
<u>Chart of Account Number</u>	<u>Detail Description</u>	<u>Cost Center ID</u>	<u>Detail Amount</u>	<u>1099 Detail Amount</u>	<u>Asset/Asset Tag</u>
05 3200 610 000 4020 0 000	PIZZA		224.00	N	In Full

Vendor ID: VALENTINO VALENTINO'S **PO Number:** **Invoice Number: 1786,1782,1778,1789** **Amount:** **644.00**
Description: Invoice Date: 12/29/2020 Due Date: 02/15/2021 Status: PP 1099 Amount: 0.00
Sequence: 1 Check Type: Check Checking Account ID: Check Number: 12150 Check Date: 02/02/2021
Chart of Account Number Detail Description
05 3200 610 000 4020 0 000 PIZZA Cost Center ID Detail Amount 1099 Detail Amount Asset/Asset Tag In Full
644.00 N

Vendor ID: VALENTINO VALENTINO'S **PO Number:** **Invoice Number: 1796,1805,1806,1807** **Amount:** **826.00**
Description: Invoice Date: 02/05/2021 Due Date: 02/19/2021 Status: PP 1099 Amount: 0.00
Sequence: 1 Check Type: Check Checking Account ID: Check Number: 12188 Check Date: 02/09/2021
Chart of Account Number Detail Description
05 3200 610 000 4020 0 000 PIZZA Cost Center ID Detail Amount 1099 Detail Amount Asset/Asset Tag In Full
420.00 N
05 3200 610 000 4130 0 000 DANCE CAMP PIZZA 154.00 N
05 3200 610 000 4017 0 100 HOSPITALITY ROOM 252.00 N

Vendor ID: VALENTINO VALENTINO'S **PO Number:** **Invoice Number: 1798** **Amount:** **154.00**
Description: Invoice Date: 02/02/2021 Due Date: 02/16/2021 Status: PP 1099 Amount: 0.00
Sequence: 1 Check Type: Check Checking Account ID: Check Number: 12204 Check Date: 02/18/2021
Chart of Account Number Detail Description
05 3200 610 000 4130 0 000 PIZZA FOR DANCE CAMP Cost Center ID Detail Amount 1099 Detail Amount Asset/Asset Tag In Full
154.00 N

Vendor ID: VALENTINO VALENTINO'S **PO Number:** **Invoice Number: 1823** **Amount:** **70.00**
Description: Invoice Date: 02/19/2021 Due Date: 03/05/2021 Status: PP 1099 Amount: 0.00
Sequence: 1 Check Type: Check Checking Account ID: Check Number: 12229 Check Date: 02/25/2021
Chart of Account Number Detail Description
05 3200 610 000 4020 0 000 PIZZA Cost Center ID Detail Amount 1099 Detail Amount Asset/Asset Tag In Full
70.00 N

Vendor ID: VILLALOBOS VILLALOBOS, JASON **PO Number:** **Invoice Number: 21221** **Amount:** **70.00**
Description: Invoice Date: 02/11/2021 Due Date: 02/12/2021 Status: PP 1099 Amount: 70.00
Sequence: 1 Check Type: Check Checking Account ID: Check Number: 12191 Check Date: 02/12/2021
Chart of Account Number Detail Description
05 3200 150 000 4015 0 000 JV BOYS BBALL OFFICIALS Cost Center ID Detail Amount 1099 Detail Amount Asset/Asset Tag In Full
70.00 N

Vendor ID: VOSSANDY VOSS, SANDY **PO Number:** **Invoice Number: 22521** **Amount:** **30.00**
Description: Invoice Date: 02/24/2021 Due Date: 02/26/2021 Status: PP 1099 Amount: 0.00
Sequence: 1 Check Type: Check Checking Account ID: Check Number: 12220 Check Date: 02/25/2021
Chart of Account Number Detail Description
05 3200 150 000 4016 0 000 NSAA SUB STATE CLOCK Cost Center ID Detail Amount 1099 Detail Amount Asset/Asset Tag In Full
30.00 N

Vendor ID: VRBKAHEATH VRBKA, HEATH **PO Number:** **Invoice Number: 2092021** **Amount:** **30.00**
Description: Invoice Date: 02/06/2021 Due Date: 02/06/2021 Status: PP 1099 Amount: 0.00
Sequence: 1 Check Type: Check Checking Account ID: Check Number: 12181 Check Date: 02/09/2021
Chart of Account Number Detail Description
05 3200 150 000 4017 0 000 SUB DISTRICT TRACK WRESTLING Cost Center ID Detail Amount 1099 Detail Amount Asset/Asset Tag In Full
30.00 N

Vendor ID: VRBKAHEATH VRBKA, HEATH **PO Number:** **Invoice Number: 2921** **Amount:** **30.00**

Invoice Listing - Detail

Description:		Invoice Date: 01/02/2021	Due Date: 02/12/2021	Status: PP	1099 Amount: 0.00
Sequence: 1	Check Type: Check	Checking Account ID: 5	Check Number: 12175	Check Date: 02/09/2021	
<u>Chart of Account Number</u>	<u>Detail Description</u>	<u>Cost Center ID</u>	<u>Detail Amount</u>	<u>1099 Detail Amount</u>	<u>Asset/Asset Tag</u>
05 3200 150 000 4017 0 000	WRESTLING INVITE SCORE CLOCK		30.00		N
Vendor ID: WALMAR WAL-MART					
Description:		PO Number:	Invoice Number: 22121	Amount:	417.50
Sequence: 1	Check Type: Check	Invoice Date: 01/20/2021	Due Date: 03/14/2021	Status: PP	1099 Amount: 0.00
<u>Chart of Account Number</u>	<u>Detail Description</u>	<u>Cost Center ID</u>	<u>Detail Amount</u>	<u>1099 Detail Amount</u>	<u>Asset/Asset Tag</u>
05 3200 610 000 4020 0 000	BUNS, HOT DOGS, PICKLES, RELISH		417.50		N
Vendor ID: WATTSOREY WATTS, COREY					
Description:		PO Number:	Invoice Number: 2921	Amount:	30.00
Sequence: 1	Check Type: Check	Invoice Date: 02/05/2021	Due Date: 02/06/2021	Status: PP	1099 Amount: 0.00
<u>Chart of Account Number</u>	<u>Detail Description</u>	<u>Cost Center ID</u>	<u>Detail Amount</u>	<u>1099 Detail Amount</u>	<u>Asset/Asset Tag</u>
05 3200 150 000 4017 0 000	SUB-DISTRICT WRESTLING		30.00		N
Vendor ID: WEMHOFF WEMHOFF, ERIC					
Description:		PO Number:	Invoice Number: 21221	Amount:	135.00
Sequence: 1	Check Type: Check	Invoice Date: 02/11/2021	Due Date: 02/12/2021	Status: PP	1099 Amount: 135.00
<u>Chart of Account Number</u>	<u>Detail Description</u>	<u>Cost Center ID</u>	<u>Detail Amount</u>	<u>1099 Detail Amount</u>	<u>Asset/Asset Tag</u>
05 3200 150 000 4016 0 000	VARSITY GIRLS/BOYS BBALL OFFICIALS		135.00		N
Vendor ID: WILTONCLAR WILTON, CLARE					
Description:		PO Number:	Invoice Number: 021821	Amount:	80.00
Sequence: 1	Check Type: Automatic Payment	Invoice Date: 02/16/2021	Due Date: 02/18/2021	Status: AP	1099 Amount: 80.00
<u>Chart of Account Number</u>	<u>Detail Description</u>	<u>Cost Center ID</u>	<u>Detail Amount</u>	<u>1099 Detail Amount</u>	<u>Asset/Asset Tag</u>
05 3200 890 000 4190 0 000	CERTIFIED JUDGE AT SPEECH MEET		80.00		N
Vendor ID: WILTONCLAR WILTON, CLARE					
Description:		PO Number:	Invoice Number: 20221	Amount:	80.00
Sequence: 1	Check Type: Check	Invoice Date: 02/01/2021	Due Date: 02/01/2021	Status: PP	1099 Amount: 80.00
<u>Chart of Account Number</u>	<u>Detail Description</u>	<u>Cost Center ID</u>	<u>Detail Amount</u>	<u>1099 Detail Amount</u>	<u>Asset/Asset Tag</u>
05 3200 890 000 4190 0 000	CERTIFIED JUDGE LONGVIEW SPEECH MEET		80.00		N
Vendor ID: WILTONCLAR WILTON, CLARE					
Description:		PO Number:	Invoice Number: 20521	Amount:	80.00
Sequence: 1	Check Type: Check	Invoice Date: 02/01/2021	Due Date: 02/06/2021	Status: PP	1099 Amount: 80.00
<u>Chart of Account Number</u>	<u>Detail Description</u>	<u>Cost Center ID</u>	<u>Detail Amount</u>	<u>1099 Detail Amount</u>	<u>Asset/Asset Tag</u>
05 3200 890 000 4190 0 000	CERTIFIED JUDGE		80.00		N
Vendor ID: WILTONCLAR WILTON, CLARE					
Description:		PO Number:	Invoice Number: 21821	Amount:	80.00
Sequence: 1	Check Type: Check	Invoice Date: 02/15/2021	Due Date: 02/18/2021	Status: PP	1099 Amount: 80.00
<u>Chart of Account Number</u>	<u>Detail Description</u>	<u>Cost Center ID</u>	<u>Detail Amount</u>	<u>1099 Detail Amount</u>	<u>Asset/Asset Tag</u>
05 3200 890 000 4190 0 000	CERTIFIED JUDGE		80.00		N

Activity Director's Report: March

Congratulations to the follow activities:

- Wrestling - Grady Belt on state tourney bid
- Speech - Mrs. Wilton, Mrs. Blackburn & Speech Team
 - CRC Champions
 - State Qualifiers - March 19 (Horizon Middle School - Kearney)
 - Haley Hanak -Poetry (District Champ) & Serious
 - Fischer White & Aiden Zimmerman - Duet
 - Cassie Ziemba - Serious
 - Jenna Potter - Entertainment
- Band & Choir - SRC students selected to perform in CRC Honor Band & Choir
 - Band - Maddie Hopwood, Reece Ingalls, Kira Pavlik, Emily Willis
 - Choir - Haley Hanak

Participation Numbers

- Boys Golf - 9
- Track and Field - 36
- Jr. High Track and Field - anticipated 33

CRC Honor Band/Choir (March 22 at Nebraska Lutheran)

NSAA Winter Academic All-State Recipients:

- BBB: Colin Wingard & Gavin Dutton-Mofford
- GBB: Maddie Hopwood and Kira Pavlik
- Wrestling: Grady Belt
- Speech: Fischer White & Cassie Ziemba

Hosted Events:

- Girls Basketball District Final (Winner - Humphrey)
- CRC Conference Tournament (Winners - Cross County and Osceola)
- Youth Girls Volleyball Tournament (March 21)
- SpikeFest (March 19 & 20) - NO HOOP FEST
- Elementary Track & Field Day - May 12

SRC Board of Education
Elementary Principal Board Report
March 15, 2021

“One School, One Book” Program: See Attached Letter

Girls on the Run - Carrie Bauers is in charge of this program for 2021. Notes have gone home with 3-4-5 girls. The final 5K will not take place in York. Each school will host their own run and send video coverage to the York District Representative.

Family Fun Night took place on March 2nd. 90 parents signed into the event. This was the Title I family night. Presentations were made on One School, One Book, activities included making lava lamps, geography Bingo, reading with The Cat in the Hat, board games, science activities, puppet show, creating hats, dancing, an appreciation board, and more. Cotton Candy was served to all who attended by Bill Acamo from Fluff and Stuff from Osceola. This was the largest attended family activity next to the new edition Open House. (See attached Pictures)

ACT Testing Day - No elementary in attendance. The entire elementary faculty and staff will be training in CPR on that day. Training/discussion on grading practices will take place. Summer School planning/curriculum discussion is also on the schedule.

The PBiS Self Assessment Survey (SAS) for all staff was submitted by the elementary faculty at their meeting on the morning of March 15. Paraprofessionals at the elementary level submitted their SAS after school on March 15.

Elementary Track and Field Day has been scheduled for May 12.

The Fifth Grade Science Fair will take place on the evening of May 12.

Mr. Evans has ordered music for the Spring Programs and work has begun to plan those concerts. Due to the number of students in both the K-2 and 3-5 sections, the concerts may be held in the South Gym this year.



Letter Home to Families for One School, One Book
***Escape From Mr. Lemoncello's Library* (2013)**
by Chris Grabenstein

Dear Parent/Guardian:

Our school is about to take part in a special, communitywide shared reading event. Every family will receive a copy of the same book – *Escape From Mr. Lemoncello's Library* by Chris Grabenstein – and will be asked to read it together at home over the next few weeks. I am personally asking you to make the time so that your family can participate in this special activity.

Reading aloud at home is valuable because it better prepares your child to be an effective reader, and it is also a fun, worthwhile family activity. With this program, we aim to build a Community of Readers at our school. Everyone – students, parents, teachers, even administrative staff – will all be following along together.

Your child will receive a copy of *Escape From Mr. Lemoncello's Library* at a special schoolwide assembly introducing the program and the book. Along with the book, you will receive a reading schedule so that you can keep up at home. Generally, you will be asked to read about 15 minutes each night.

In school, your child will be invited to answer daily trivia questions to encourage and reward attentive listening. You will soon find that your child will take pride in knowing and anticipating the details of the story. In class, students will explore the book through activities and discussion. You will want to make sure your family keeps up so that your child can be included. Throughout the month, everyone will be talking about *Escape From Mr. Lemoncello's Library*!

This is a novel program in that children of all grade levels will all be listening to the same book. Strange or daring as that may seem, it actually makes sound educational sense. Reading professionals recommend reading material out loud that is beyond a child's own reading level. We also believe that you can and should continue reading chapter books with your older children, even when they are able to read by themselves. We have selected a title that can be followed and understood and enjoyed by younger students, but will still captivate and stimulate older children.

I know that you'll enjoy this special reading time with your children. I hope to talk with both you and your student sometime in the days to come about Kyle Keeley and his biggest game yet. "When a whole school reads a book, there's a lot to talk about." With your help, we can build a Community of Readers at our school.

– Mrs. Glock, Principal

Every Family. Every School. Every Night.®



Shelby-Rising City Schools
6-12 Board Report- Cody Bobolz
March 15, 2020 7:30 pm

1. National FFA Week- February 22-26

Mrs. Segner and her FFA crew did a great job throughout the entire week. They had dress up days for each day and a trivia question, which was announced during Advisory. They ended the week with the inaugural Ag Olympics and a petting zoo. It was a great way to promote FFA and the officers did a great job of organizing the activities.

2. February Husky Recognition Rally- February 26

The February Husky Recognition Rally was held on Friday, February 26th. During the rally we recognized our back-to-back CRC Conference Championship Speech Team! Our SRC Dance Team was also recognized for being the Jazz C2 State Champion! Mrs. Segner recognized her FFA participants and their accomplishments thus far this year. Our National Honor Society spoke to the students about the upcoming Food Drive. We also celebrated those students who were selected February Students of the Month and held our monthly PBiS drawing. It was a great rally that was capped off with the inaugural Ag Olympics!

February Students of the Month



6th- Jaclynn Prigge
7th- Kadence Calahan
8th- Mackenzie Kuns
9th- Aubree Siffring

10th- Jenna Potter
11th- Grady Belt
12th- Colin Wingard

3. National Honor Society Food Drive- March 3rd & 4th

National Honor Society members held their annual Food Drive. Students were asked to bring in items each morning. All the items donated go to people in our community and/or the elderly that have difficulty making ends meet. The classes in the high school and middle school with the highest totals were awarded with an “ice cream/cell phone usage fiesta” at the end of the day on Tuesday, March 9th. Mrs. Hernbloom and her NHS students did a great job of organizing and carrying out the food drive. Very proud of our kids and the organization!

HIGH/MIDDLE SCHOOL DIVISION:

WINNER with 119 points was 7th Grade

2. 6th grade-107 points
3. 12th grade-93 points
4. 11th grade-78 points
5. 9th grade-45 points
6. 8th grade-14 points
7. 10th grade-7 points

4. February Staff of the Month

Service- Mandy Peterson
Innovation- Morgan Segner
Integrity- Denise Humlicek
Accountability- John Schoenrock



5. Assessment Season- March-May

We have a lot of standardized testing coming up in March and April.

- Our juniors are taking the ACT on Tuesday, March 23rd, which will include the writing portion this year.
- Students in grades 3-8 will be taking the NSCAS Growth Phase I Pilot in April in the areas of Math, ELA, and Science.
- Students in grades K-11 will be taking the Spring MAP assessments in May in the areas of Math, ELA, and Science.

Details about the NSCAS Growth:

- One of the big announcements was the new name... drum roll... NSCAS Growth
- Phase I of NSCAS Growth takes place this spring in ELA & Math. Districts will only receive individual results.
- The science test this spring is a field test and they are testing the test. Districts will
- Phase 2 pilot of NSCAS Growth will be next winter in ELA & Math
- Goal is to be fully operational with NSCAS Growth by the fall of 2022
- Overall goal of NSCAS Growth is to provide students 3 different points where they can prove mastery of the standards
- Scores and reports will look similar to that of MAP Growth testing. RIT scores will be used.

There is also a link to the assessment page on NDE providing more information on [NSCAS Innovation](#).

/ 2022-2023 Timeline Fully Operational

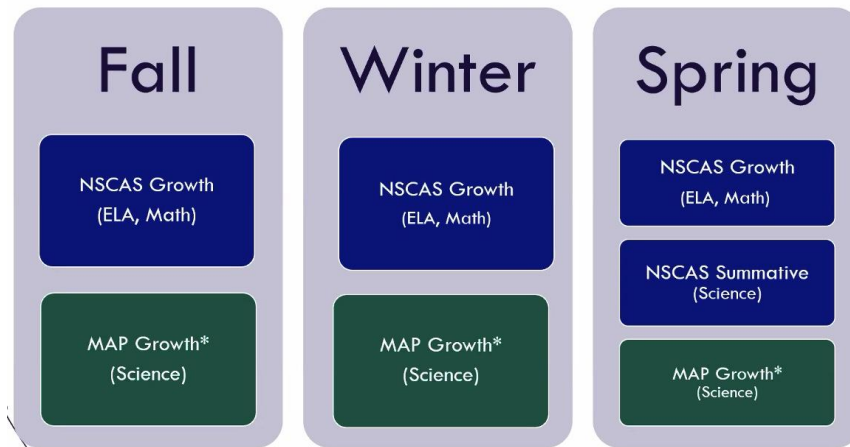

6. ICU Update- As of 3/10/21

- Approximately 860 assignments completed 3rd quarter
- Held our Blitz Day on Friday, March 5th in the afternoon- highest number of students participated in this blitz day compared to the previous two
- Continuing to emphasize the importance of quality assignments and meaningful practice

- Visited with staff at our last meeting about making sure we are formatively assessing frequently to make sure we know that students are ready to assess

ICU DATABASE DASHBOARD

3,157

ASSIGNMENTS COMPLETED

NUMBER OF CURRENT
MISSING ASSIGNMENTS

23

NUMBER OF STUDENTS
MISSING ASSIGNMENTS

19

Missing Assignments (Total YTD)

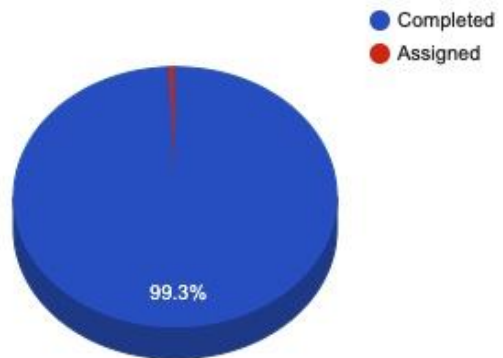

March Board Report

Days worked to date: 160

Days off: March 8, 9, 10

State Aid Projections: We received our projections for the next school year. At this point we should receive \$539,286. That is down about \$107K from last year. It is my understanding that this number varies from year to year.

Mr. Tejkl and I will be attending a NASB Budget workshop in Norfolk at the end of the month. After that, we will start working on the document so that it is mostly done before I leave in June.

We received a \$100 donation from Bob Power as a memorial for the former teachers that died this past year. The money was designated to pay for lunch balances that were in arrears to enable students to purchase seconds. His donation cleared the balances for 30 students. There are fewer than 10 students that owe lunch balances at this time.

We are proceeding with determining staffing issues for the next school year. There are a couple of staff members who are applying for jobs outside of the district. We are also aware of at least one para who will not return next year.

I will be putting in a request for CARES II funding. The district has been allocated over \$200K that can be used for a variety of items.

We had intended to host the overnight for the BRAN this year. However, the event has been canceled until 2022.

Steve and I found out that Keep Columbus Beautiful will be able to dispose of our outdated/unusable chemicals in September. We will locate a safer storage place until that time. This will save the district several thousand dollars.

We will need a negotiations committee meeting to finalize the salaries of the classified staff members.

Steve and I will be starting to work on a summer maintenance schedule prior to the next BOE meeting.

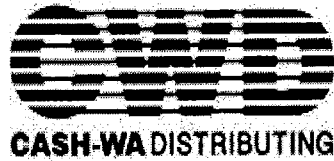

To:
Shelby Public School
Brenda Gates
650 N. Walnut Street
Shelby, NE 68662
402-527-5946 (Contact)

Project:
Shelby Public School

From:
Cash-Wa Distributing Co.
Randy Kratochvil
401 West 4th Street
Kearney, NE 68848
800-652-0010 EXT. 7241
FAX (308) 234-4372

Customer 200910

Job Reference Number: 8905

Table with 5 columns: Item, Qty, Description, Sell, Sell Total. Contains two rows for Milk Coolers (Item 1 and Item 2) and a summary section for ITEM TOTAL, Merchandise, and Total.

Prices guaranteed for 30 Days, Special Order items CANNOT be returned

All material is guaranteed to be specified and the above work to be performed in accordance with the drawings and specifications submitted for above work and completed in a substantial workmanlike manner for the sum of Dollars(\$).

Deposit: A 30%-50% down payment will be required BEFORE orders will be placed and is dependent upon account terms.

30% _____
50% _____

ACCEPTANCE OF PROPOSAL- the above prices, specifications and conditions are satisfactory and are hereby accepted. You are authorized to do the work as specified. Payment will be made as outlined. Remainder payment due within terms upon delivery.

Company: _____

Date: _____

Signature: _____

Thanks,
Randy Kratochvil
Equipment Sales Specialist
WEB LINK: www.cashwa.com/services/equipment
CashWa Distributing Company
Phone: 800-652-0010 Ext 7241
Fax: 308-234-4372
randy.kratochvil@cashwa.com

Acceptance: _____ Date: _____

Printed Name: _____

Project Grand Total: \$5,275.00

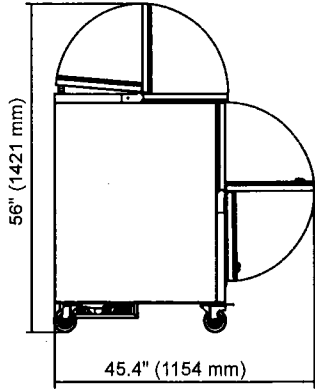

SIDE VIEW (ALL MODELS)

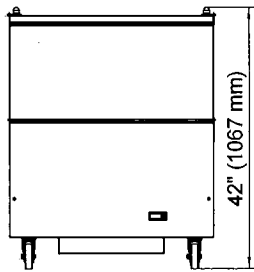

FRONT

NLMC08S

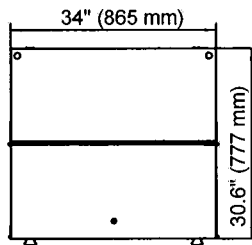

TOP

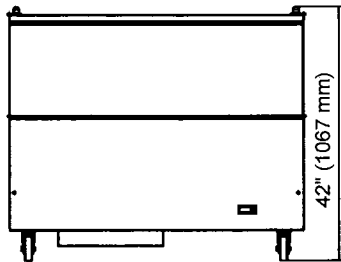

FRONT

NLMC12S

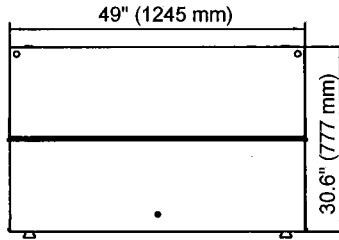

TOP

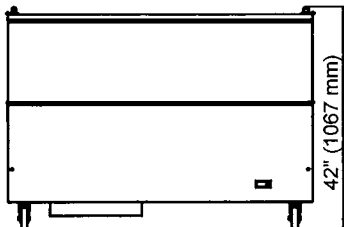

FRONT

NLMC16S

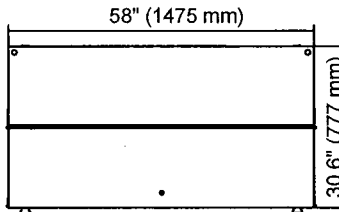

TOP

SPECIFICATIONS			
Model*	NLMC08S*	NLMC12S*	NLMC16S*
Crated Weight (lbs.) (kg)	165 (75)	212 (96)	243 (110)
Crated Height (in) (cm)	48.6 (123)	48.6 (123)	48.6 (123)
Crated Width (in) (cm)	35.8 (91)	50.8 (129)	59.8 (152)
Crated Depth (in) (cm)	32.3 (82)	32.3 (82)	32.3 (82)
Interior Height (in) (cm)	25.2 (64)	25.2 (64)	25.2 (64)
Interior Width (in) (cm)	30.9 (78)	45.9 (117)	54.9 (139)
Interior Depth (in) (cm)	26.5 (67)	26.5 (67)	26.5 (67)
Overall Height (in) (cm)	42 (107)	42 (107)	42 (107)
Overall Width (in) (cm)	34 (86)	49 (124)	58 (147)
Overall Depth (in) (cm)	30.6 (78)	30.6 (78)	30.6 (78)
Gross Cubage (CuFt) (L)	13.2 (374)	19.6 (555)	23.5 (665)
Number of Floor Racks	2	2	2
Number of Casters	4	4	4
Condensing Unit Size	1/4	1/4	1/4
Refrigerant	R290	R290	R290
Electrical Characteristics	115/60/1	115/60/1	115/60/1
Cord and Plug Furnished	Yes	Yes	Yes
Nema Plug Configuration	5-15P	5-15P	5-15P
Total Amp Draw	3.0	3.0	3.0

* Add suffix "W" for white exterior, "S" for stainless steel.

Specifications subject to change without notice.

MODEL	CASES WITH CARTONS			
	13" x 13" x 11"H		19" x 13" x 11"H	
	CASES	CARTONS	CASES	CARTONS
NLMC08S	8	352	4	288
NLMC12S	12	528	8	576
NLMC16S	16	704	10	720

MODEL	LOOSE CARTON (WITHOUT CASES)			
	FLAT TOP		PEAKED TOP (GABLE)	
	1/2 PINT	1 PINT	1/2 PINT	1 PINT
NLMC08S	864	432	680	430
NLMC12S	1368	684	1020	645
NLMC16S	1800	900	1360	860



Revision Date: 8/20
Part Number: 171224

©2020 Nor-Lake, Inc. All rights reserved.

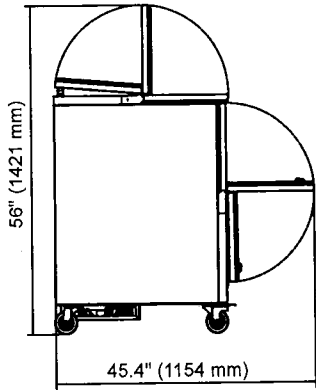

SIDE VIEW (ALL MODELS)

SPECIFICATIONS			
Model*	NLMC08S*	NLMC12S*	NLMC16S*
Crated Weight (lbs.) (kg)	165 (75)	212 (96)	243 (110)
Crated Height (in) (cm)	48.6 (123)	48.6 (123)	48.6 (123)
Crated Width (in) (cm)	35.8 (91)	50.8 (129)	59.8 (152)
Crated Depth (in) (cm)	32.3 (82)	32.3 (82)	32.3 (82)
Interior Height (in) (cm)	25.2 (64)	25.2 (64)	25.2 (64)
Interior Width (in) (cm)	30.9 (78)	45.9 (117)	54.9 (139)
Interior Depth (in) (cm)	26.5 (67)	26.5 (67)	26.5 (67)
Overall Height (in) (cm)	42 (107)	42 (107)	42 (107)
Overall Width (in) (cm)	34 (86)	49 (124)	58 (147)
Overall Depth (in) (cm)	30.6 (78)	30.6 (78)	30.6 (78)
Gross Cubage (CuFt) (L)	13.2 (374)	19.6 (555)	23.5 (665)
Number of Floor Racks	2	2	2
Number of Casters	4	4	4
Condensing Unit Size	1/4	1/4	1/4
Refrigerant	R290	R290	R290
Electrical Characteristics	115/60/1	115/60/1	115/60/1
Cord and Plug Furnished	Yes	Yes	Yes
Nema Plug Configuration	5-15P	5-15P	5-15P
Total Amp Draw	3.0	3.0	3.0

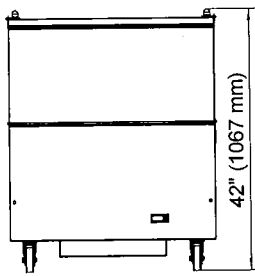

FRONT

NLMC08S

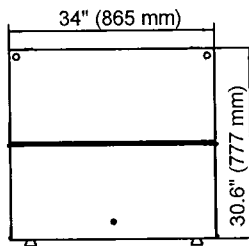

TOP

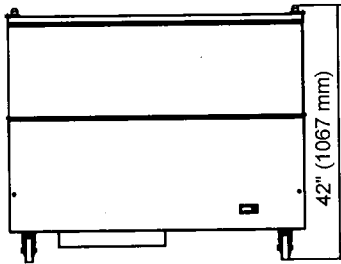

FRONT

NLMC12S

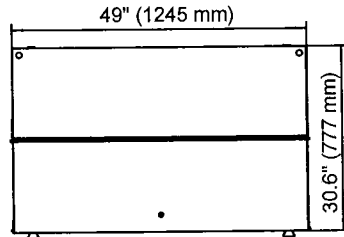

TOP

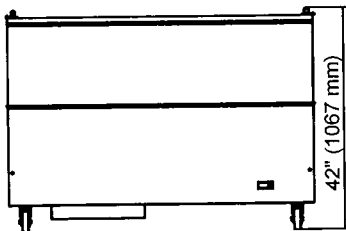

FRONT

NLMC16S

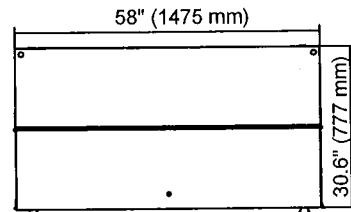

TOP

* Add suffix "W" for white exterior, "S" for stainless steel.

Specifications subject to change without notice.

MODEL	CASES WITH CARTONS			
	13" x 13" x 11"H		19" x 13" x 11"H	
	CASES	CARTONS	CASES	CARTONS
NLMC08S	8	352	4	288
NLMC12S	12	528	8	576
NLMC16S	16	704	10	720

MODEL	LOOSE CARTON (WITHOUT CASES)			
	FLAT TOP		PEAKED TOP (GABLE)	
	1/2 PINT	1 PINT	1/2 PINT	1 PINT
NLMC08S	864	432	680	430
NLMC12S	1368	684	1020	645
NLMC16S	1800	900	1360	860



Revision Date: 8/20
Part Number: 171224

©2020 Nor-Lake, Inc. All rights reserved.

Item	Qty	Description	Sell	Sell Total
<u>2</u>	1 ea	ICE MAKER, CUBE-STYLE Scotsman Model No. C0330SW-1 Prodigy Plus® Ice Maker, cube style, water-cooled, self-contained condenser, production capacity up to 420 lb/24 hours at 70°/50° (326 lb AHRI certified at 90°/70°), small cube size, AutoAlert™ indicating lights, WaterSense adjustable purge control, one-touch cleaning, harvest assist, unit specific QR code, stainless steel finish, AgION™ antimicrobial protection, 115v/60/1-ph, 13.5 amps, cULus, NSF, CE, engineered and assembled in USA	\$2,679.00	\$2,679.00
	1 ea	NOTE: Sale of this product must comply with Scotsman's MSRP Policy; contact your Scotsman representative for details		
	1 ea	3 year parts & labor warranties		
	1 ea	5 year parts & labor warranties on Evaporator		
	1 ea	5 year parts on compressor & condenser		
	1 ea	B330P Ice Bin, top-hinged front-opening door, 344 lb application capacity, for top-mounted ice maker, 30" width, rotocast plastic construction, toolless removable baffle, polyurethane insulation, polyethylene liner, includes 6" legs, NSF, engineered and assembled in USA	\$935.00	\$935.00
	1 ea	3 year parts & labor warranties		
	1 ea	SSM1-P SSM Plus Water Filter Assembly, single system, 1.67 gallons per minute max flow, designed for cubers up to 650 lb, and for flakers, nuggets & nugget dispensers up to 1,200 lb, includes AquaArmor by AgION for antimicrobial protection, NSF, cULus	\$259.00	\$259.00
Delivered Price.				
Sales Tax to be added at the time of invoicing if applicable.				
Uncrating and Installation are NOT included.				
			ITEM TOTAL:	\$3,873.00
			Merchandise	\$7,082.00
			Total	\$7,082.00

****Prices guaranteed for 30 Days, Special Order items CANNOT be returned****

All material is guaranteed to be specified and the above work to be performed in accordance with the drawings and specifications submitted for above work and completed in a substantial workmanlike manner for the sum of Dollars(\$).

Deposit: A 30%-50% down payment will be required BEFORE orders will be placed and is dependent upon account terms.

30% _____

50% _____

Direct Ship Items: Please note it is the responsibility of the customer to file all freight claims directly with the freight company. CWD will not file any direct shipment claims with the freight companies on direct shipments. **Please check all items thoroughly at time of delivery and address any issues with the carrier at the time of delivery.** We strongly suggest that on direct shipments, boxes are opened and inspected thoroughly at time of delivery **BEFORE SHIPMENTS ARE RECEIVED**, before transporter leaves the job site as concealed damage also needs to be reported directly to shipper, **IMMEDIATELY**. All freight companies have a window of time to report concealed damage otherwise they are not responsible and neither is CWD.

Supplement 1 to NMF 100-AO, effective April 18, 2015

CU3030 - 300lb Self-Contained Ice Machine

Prodigy® Undercounter Cuber with Storage

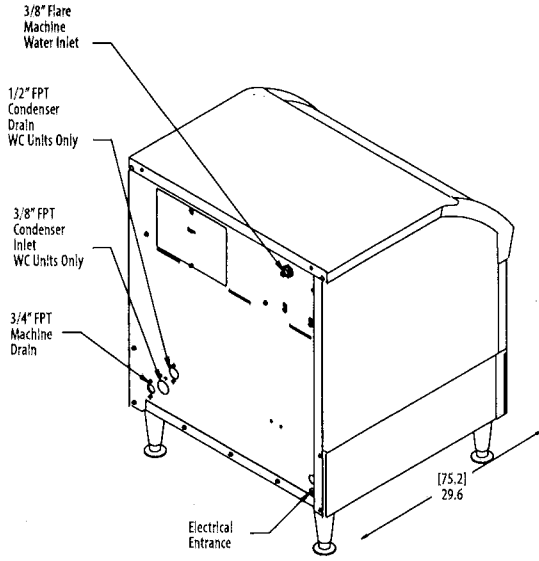

Installation Note: Allow 6" at back for utility connections

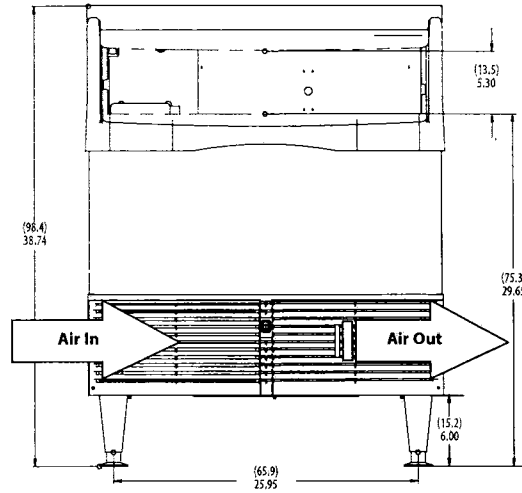

FRONT VIEW

CU3030 - 300lb Self-Contained Ice Machine



Specifications

Model Number*	Condenser Unit	Storage lb/kg	Basic Electrical Volts/Hz/Phase	Max. Fuse Size or HACR Circuit Breaker (amps)	Circuit Wires	Min. Circuit Ampacity	Energy Consumption kWh/100 lb (45.4 kg) 90°F(32°C)/70°F(21°C)	Water Usage Gallons/100 lb (liters/45.4 kg)	
								Potable 90°F(32°C)/70°F(21°C)	Condenser 90°F(32°C)/70°F(21°C)
MEDIUM	CU3030MA-1	Air 110/50	115/60/1	15	2	Cord	7.35	18.0/68.2	-
	CU3030MA-32	Air 110/50	208-230/60/1	15	2	Cord	7.35	18.0/68.2	-
LARGE	CU3030SA-1	Air 110/50	115/60/1	15	2	Cord	7.35	18.0/68.2	-
	CU3030SA-32	Air 110/50	208-230/60/1	15	2	Cord	7.35	18.0/68.2	-
	CU3030SW-1	Water 110/50	115/60/1	15	2	Cord	5.22	18.0/68.2	150/586



All Models

Dimensions (W x D x H):

Unit: 30" x 30" x 33"
(76.2 x 76.2 x 83.8 cm)

Shipping Carton: 33" x 33" x 39.5"
(83.8 x 83.8 x 100.3 cm)

Shipping Weight: 230 lb / 104 kg

BTUs per hour: 5,200

Refrigerant: R-404A



Accessories

Model Number	Description
KLP8S	Kit 6 inch leg SS
KPUFM30	Kit Prodigy undercounter floor mount 30 inch for CU3030 (add .5" to height)

Scotsman recommends all ice machines have water filtration. See Scotsman water filter specification sheet for details.



Operating Requirements

	Minimum	Maximum
Air Temperatures	50°F (10°C)	100°F (38°C)
Water Temperatures	40°F (4.4°C)	100°F (38°C)
Remote Cond. Temps	-20°F (-29°C)	120°F (49°C)
Water Pressures	20 PSIG (1.4 bar)	80 PSIG (5.5 bar)
Electrical Voltage	-5%	+10%

Specifications and design are subject to change without notice.

Water Filters

SSM Plus and Aqua Patrol Plus® Water Filtration Systems

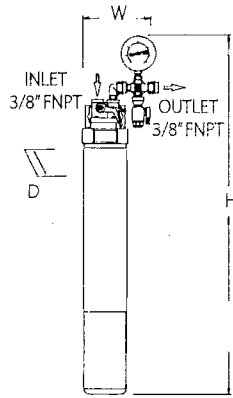

SSM1-P & AP1-P

SSM2-P & AP2-P

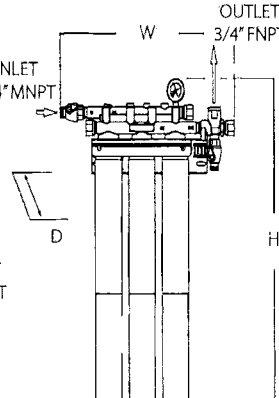
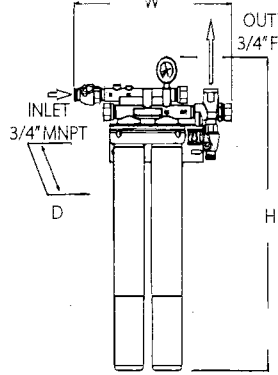

SSM3-P & AP3-P

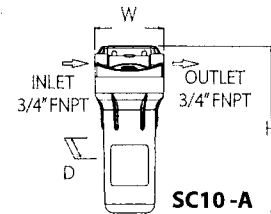

SC10-A

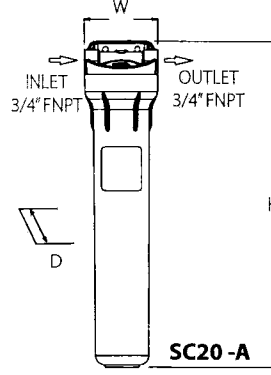

SC20-A



Specifications

	Model Number	Dimensions			Description	Maximum Flow (gallons/minute)
		W	D	H		
SSM Plus	SSM1-P	5.6	4.75	30.5	Single System for Cubers up to 650 lb (295 kg) and flakers, nuggets and nugget dispensers up to 1,200 lb (544 kg).	1.67
	SSM2-P	16.6	5.5	29.26	Double System for Cubers up to 650 lb (295 kg) and flakers, nuggets and nugget dispensers up to 1,200 lb (544 kg).	3.34
	SSM3-P	21	5.5	29.26	Triple System for Cubers over 1,300 lb (544 kg)	5.01
AquaPatrol Plus®	AP1-P	5.6	4.75	21.5	Single System for Cubers up to 650 lb (295 kg) and flakers, nuggets and nugget dispensers up to 1,200 lb (544 kg).	2.1
	AP2-P	16.6	5.5	19.26	Double System for Cubers up to 650 lb (295 kg) and flakers, nuggets and nugget dispensers up to 1,200 lb (544 kg).	4.2
	AP3-P	21	5.5	19.26	Triple System for Cubers over 1,300 lb (544 kg)	6.3
Coarse Pre-Filters	SC10-A	5.16	5.5	12.44	Single System for Cubers up to 650 lb (295 kg) and flakers, nuggets and nugget dispensers up to 1,200 lb (544 kg).	5
	SC20-A	5.16	5.5	22.44	Single System for Cubers up to 650 lb (295 kg) and flakers, nuggets and nugget dispensers up to 1,200 lb (544 kg).	10



Shipping

Model Number	Dimensions	Weight (lb/kg)
SSM1-P:	21" x 10" x 6"	7/3
SSM2-P:	26" x 16" x 13"	11/5
SSM3-P:	26" x 16" x 13"	16/7
AP1-P:	10" x 21" x 6"	7/3
AP2-P:	16" x 26" x 13"	11/5
AP3-P:	16" x 26" x 13"	16/7
SC10-A:	6" x 6" x 17"	5/2
SC20-A:	6" x 6" x 26"	11/5



Accessories

Model Number	Description
SC10RC40	SC10 Replacement Filter (package of 40)
SC20RC20	SC20 Replacement Filter (package of 20)
SSMRC1	Replacement Cartridge for SSM Plus (package of 1)
SSMRC6	Replacement Cartridge for SSM Plus (package of 6)
APRC6-P	Replacement Cartridge for AquaPatrol Plus® (package of 6)
APRC1-P	Replacement Cartridge for AquaPatrol Plus® (package of 1)

Scotsman recommends all ice machines have water filtration.



Operating Requirements

	Minimum	Maximum
Air Temperatures	50°F (10°C)	100°F (38°C)
Water Temperatures	40°F (4.4°C)	100°F (38°C)
Water Pressures	20 PSIG (1.4 bar)	80 PSIG (5.5 bar)

Specifications and design are subject to change without notice.

Water Filters

C0330 - 300lb Cube Ice Machine

Prodigy Plus® Modular Cube Ice Machine

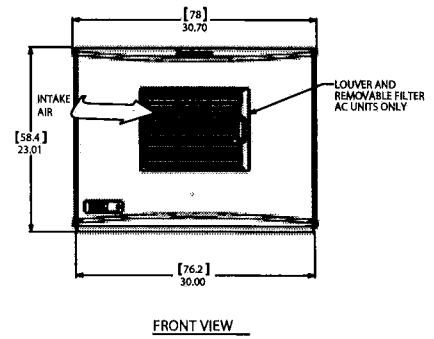
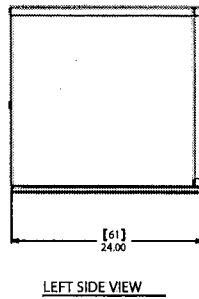
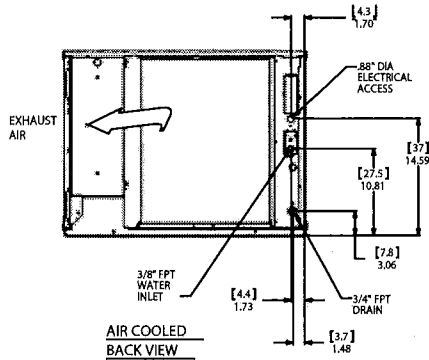
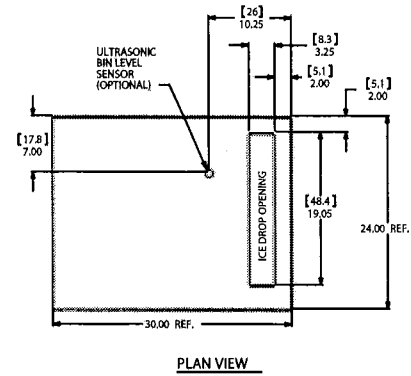
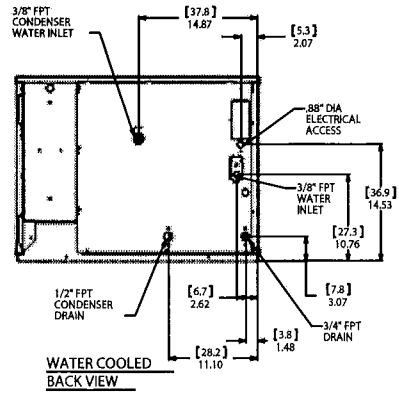

C0330 - 300lb Cube Ice Machine



Specifications

Model Number	Condenser Unit	Basic Electrical Volts/Hz/Phase	Max. Fuse Size or HACR Circuit Breaker (amps)	Circuit Wires	Min. Circuit Ampacity	Energy Consumption kWh/100 lb (45.4 kg) 90°F(32°C)/70°F(21°C)	Water Usage Gallons/100 lb (liters/45.4 kg)	
							Potable	Condenser 90°F(32°C)/70°F(21°C)
med. C0330MA-1	Air	115/60/1	15	2	14.3	6.23	18.0/68.1	-
C0330MW-1	Water	115/60/1	15	2	13.5	4.97	18.0/68.1	139.0/526.2
C0330MA-32	Air	208-230/60/1	15	2	7.1	6.23	18.0/68.1	-
sm. C0330SA-1	Air	115/60/1	15	2	14.3	6.23	18.0/68.1	-
C0330SW-1	Water	115/60/1	15	2	13.5	4.97	18.0/68.1	139.0/526.2



All Models

Dimensions (W x D x H):

Unit: 30" x 24" x 23"
(76.2 x 61.0 x 58.4 cm)

Shipping Carton: 33.5" x 27.5" x 28"
(85.1 x 69.9 x 71.1 cm)

Shipping Weight: 155 lb / 70 kg BTUs per hour: 5,200

Refrigerant: R-404A



Accessories

Model Number	Description
KVS	Vari-Smart™ Ice Level Control - Program ice bin levels to match ice needs.
KSBU	Smart-Board™ Advanced Control - Use additional operational data for fast diagnosis.
KSBU-N	Smart-Board™ Advanced Control with Network - Network capable.
KPAS	Prodigy Advanced Sustainability Kit - Includes KVS and KSBU - N
KPPSA323	Prodigy Plus® Side Air Flow Kit for C0330, C0530 and C0630

Scotsman recommends all ice machines have water filtration. See Scotsman water filter specification sheet for details.



Operating Requirements

	Minimum	Maximum
Air Temperatures	50°F (10°C)	100°F (38°C)
Water Temperatures	40°F (4.4°C)	100°F (38°C)
Remote Cond. Temps	-20°F (-29°C)	120°F (49°C)
Water Pressures	20 PSIG (1.4 bar)	80 PSIG (5.5 bar)
Electrical Voltage	-5%	+10%

Specifications and design are subject to change without notice.

B322S, B330P, B530P/S, B842S, B948S - Storage Bins
Modular Storage Bins

Installation Note: Allow 6" space at back for utility connections.

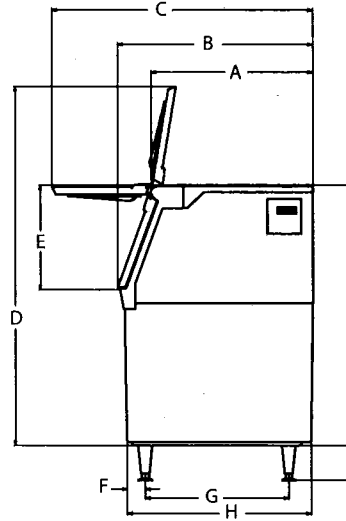
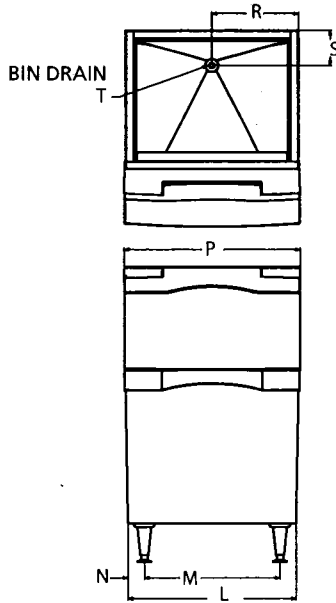

B322S, B330P, B530P/S, B842S, B948S - Storage Bins



Dimensions

Model #	A	B	C	D	E	F	G	H	J	K	L	M	N	P	R	S	T
B322S	28.23	34	45.5	61.24	18	3.88	25	32.75	44	6	22	15.5	3.25	22.5	11	6	.75 NPT
B330P	28.15	34	45.5	47.24	18	3.33	25	32.42	31	6	30	23.5	3.08	30.5	15	6	.75 NPT
B530P/S	28.15	34	45.5	61.24	18	3.09	25	31.93	44	6	30	23.5	2.83	30.5	15	6	.75 NPT
B842S	28.07	34	45.5	61.87	18	3.88	25	32.75	44	6	42	35.5	3.25	42.5	21	6	.75 NPT
B948S	28.05	34	45.5	61.24	18	3.88	25	32.75	44	6	48	41.5	3.25	48.5	24	6	.75 NPT



Overall Dimensions

Model #	Carton (W x D x H)*
B322S	22" x 34" x 44"
B330P	30" x 34" x 31"
B530P	30" x 34" x 44"
B530S	30" x 34" x 44"
B842S	42" x 34" x 44"
B948S	48" x 34" x 44"

* Add 6" Height for bin legs.



Accessories*

Model Number	Description
KBC1	Kit, bit casters for B530S, B842S, B948S and SB380.** Not for use with B322S or SB480 when using extensions.
KBC1P	Kit, bin casters for B330P and B530P.**
KLP7	Kit, legs, 6", flanged feet, for B bins, HD dispensers, AFE, CU1/2/3 and NSE.
KLP8S	Kit, legs, 6", stainless steel, for B bins, HD dispensers, AFE, CU1/2/3 and NSE.
BGS10	Bagger, hooks on any bin.
KBAG	Kit, bags, 1000, for BGS10.
KSEALER	Kit, tape sealer, for BGS10.
KTAPE	Kit, tape, 180 ft. roll, for BGS10.
KHOLDER	Kit, scoop holder, stainless steel.

**3.5" Diameter, 2 locking, raises bin 4.5".



Shipping Information

Model #	Carton (W x D x H)	Weight (lb/kg)
B322S	26" x 36" x 49"	140/64
B330P	33" x 36" x 35"	90/41
B530P	33" x 37" x 49"	110/50
B530S	33" x 37" x 49"	150/68
B842S	45" x 36" x 49"	190/86
B948S	51" x 36" x 49"	209/95

an All Group Company

- 101 Corporate Woods Parkway, Vernon Hills, IL 60061
- 1-800-SCOTSMAN Fax: 847-913-9844
- www.scotsman-ice.com customer.relationships@scotsman-ice.com
- © 2020 Scotsman Ice Systems.



The Spirit of Excellence



SIS-SS-BIN-NG 09-20

Water Filters

SSM Plus and Aqua Patrol Plus® Water Filtration Systems

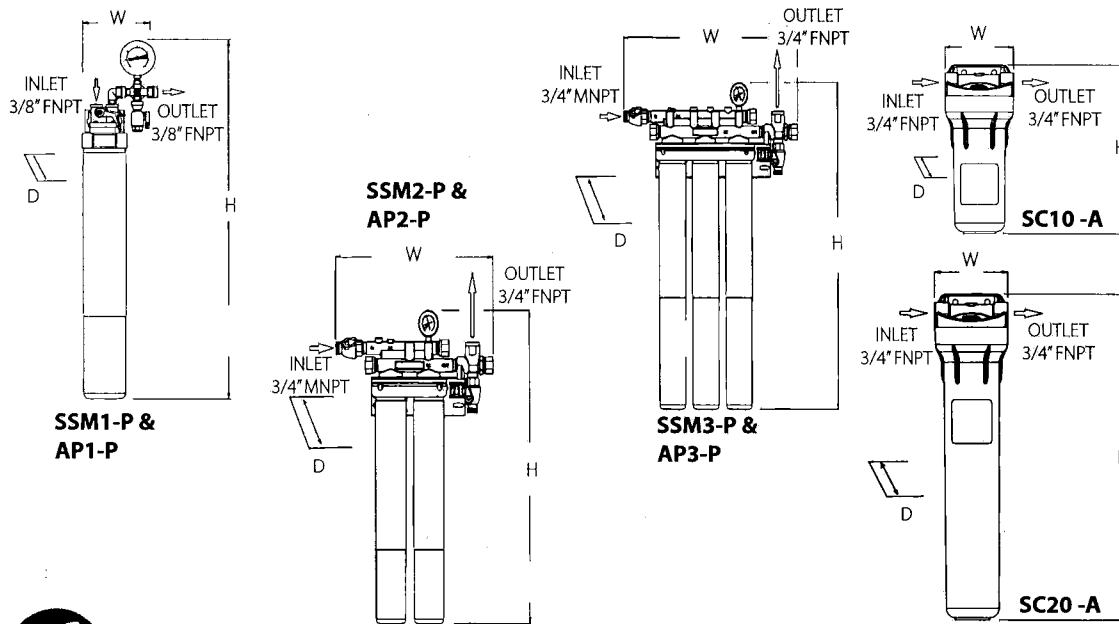

Specifications

	Model Number	Dimensions			Description	Maximum Flow (gallons/minute)
		W	D	H		
SSM Plus	SSM1-P	5.6	4.75	30.5	Single System for Cubers up to 650 lb (295 kg) and flakers, nuggets and nugget dispensers up to 1,200 lb (544 kg).	1.67
	SSM2-P	16.6	5.5	29.26	Double System for Cubers up to 650 lb (295 kg) and flakers, nuggets and nugget dispensers up to 1,200 lb (544 kg).	3.34
	SSM3-P	21	5.5	29.26	Triple System for Cubers over 1,300 lb (544 kg)	5.01
AquaPatrol Plus®	AP1-P	5.6	4.75	21.5	Single System for Cubers up to 650 lb (295 kg) and flakers, nuggets and nugget dispensers up to 1,200 lb (544 kg).	2.1
	AP2-P	16.6	5.5	19.26	Double System for Cubers up to 650 lb (295 kg) and flakers, nuggets and nugget dispensers up to 1,200 lb (544 kg).	4.2
	AP3-P	21	5.5	19.26	Triple System for Cubers over 1,300 lb (544 kg)	6.3
Coarse Pre-Filters	SC10-A	5.16	5.5	12.44	Single System for Cubers up to 650 lb (295 kg) and flakers, nuggets and nugget dispensers up to 1,200 lb (544 kg).	5
	SC20-A	5.16	5.5	22.44	Single System for Cubers up to 650 lb (295 kg) and flakers, nuggets and nugget dispensers up to 1,200 lb (544 kg).	10



Shipping

Model Number	Dimensions	Weight (lb/kg)
SSM1-P:	21" x 10" x 6"	7/3
SSM2-P:	26" x 16" x 13"	11/5
SSM3-P:	26" x 16" x 13"	16/7
AP1-P:	10" x 21" x 6"	7/3
AP2-P:	16" x 26" x 13"	11/5
AP3-P:	16" x 26" x 13"	16/7
SC10-A:	6" x 6" x 17"	5/2
SC20-A:	6" x 6" x 26"	11/5



Accessories

Model Number	Description
SC10RC40	SC10 Replacement Filter (package of 40)
SC20RC20	SC20 Replacement Filter (package of 20)
SSMRC1	Replacement Cartridge for SSM Plus (package of 1)
SSMRC6	Replacement Cartridge for SSM Plus (package of 6)
APRC6-P	Replacement Cartridge for AquaPatrol Plus® (package of 6)
APRC1-P	Replacement Cartridge for AquaPatrol Plus® (package of 1)

Scotsman recommends all ice machines have water filtration.



Operating Requirements

	Minimum	Maximum
Air Temperatures	50°F (10°C)	100°F (38°C)
Water Temperatures	40°F (4.4°C)	100°F (38°C)
Water Pressures	20 PSIG (1.4 bar)	80 PSIG (5.5 bar)

Specifications and design are subject to change without notice.

Water Filters

Thanks,
Randy Kratochvil
Equipment Sales Specialist
WEB LINK: www.cashwa.com/services/equipment
CashWa Distributing Company
Phone: 800-652-0010 Ext 7241
Fax: 308-234-4372
randy.kratochvil@cashwa.com

Acceptance: _____ Date: _____

Printed Name: _____

Project Grand Total: \$7,082.00

AGREEMENT

CONTRACTED LEVEL I, II, AND III SPECIAL EDUCATION SERVICES

THIS AGREEMENT, made and entered into this 26th day of February 2021 by and between Educational Service Unit 7 of the State of Nebraska, hereinafter called "Servicing Agency" and Shelby Rising City hereinafter called "District".

WITNESSETH:

1. That the Serving Agency does hereby agree that it will furnish to the District the following described Special Education services which meet the requirements of the State Department of Education. All rates are subject to the approval of the State Department of Education, and will be provided to the district prior to the district's budget preparation.
2. That the Serving Agency does hereby agree it will furnish to the District the following described special education services as follows:
3. Services shall be provided only to children who qualify for such services as specified in State Department of Education, Special Education Rules and Regulations (Rule 51).
4. The Servicing Agency shall supply recorded information on each child for whom services are contracted. The Servicing Agency agrees that it will confer with the School District personnel for purposes of evaluating each child's progress.
5. The placing of a child in said program shall be made by joint decision of the Servicing Agency, the District, parents and/or guardians, and other members of the IEP team.
6. The Servicing Agency agrees to perform the services and the District agrees to pay in accordance with the Servicing Agency rate schedule as approved by the Nebraska State Board of Education. This schedule shall be in full force and effect during the school year of 21-22 commencing no earlier than August 1, 2021 and ending no later than July 31, 2022.
7. The Servicing Agency retains the right to designate personnel to provide services. All personnel provided by the Servicing Agency shall be endorsed to provide their respective services.
8. Policies regarding sick leave, personal leave, and professional leave shall be determined by the negotiated agreement with the Servicing Agency for personnel providing services to the District.
9. In the event that school district's programming requirements and needs change at any time subsequent to and during the term of this agreement, the costs to the school established by this agreement, shall in mutual agreement between ESU 7 and the school district be adjusted and prorated and the parties may agree. Nothing in this paragraph, however, shall be construed to entitle the school district to abrogate this contract or declare it void. The district shall be obligated to pay all sums specified by this contract as due and owing the ESU 7 regardless of changes in circumstances within the district during the course of this contract. The ESU 7 shall, however, be obligated to meet with the school district and discuss in good faith alternatives to mitigating expense, reallocating staff, and other resources within the bounds of the law and as the ESU 7 may

in its sole discretion determine to be in the best interest of ESU 7 and the school district. Any and all changes or expenses incurred by ESU 7 in the course of performing its obligations pursuant to this agreement, or in preparing to do so, shall become due and payable by school district to ESU 7 upon billing in a manner consistent with the billing provision of this agreement.

10. If, for any reason the District does not pay as agreed, the Servicing Agency may cancel this contract and forthwith, without notice, refuse further services to said district, but the District shall not be relieved from paying for services rendered by the Servicing Agency to the said District to date of termination of service.

11. The School District agrees that its payments will be made upon receipt of billing from the Servicing Agency.

12. It is understood and agreed, that in the event of any reason this contract does not comply with the State's requirement, it will be changed in accordance therewith, upon written notice by the Servicing Agency to the District and advising the District of the required changes to meet State requirements.

13. It is agreed this contract between the Servicing Agency and district must be signed by the District Board or Representative and returned to the Servicing Agency by March 31, 2021. The Servicing Agency's Board will then sign and return a copy of the contract to the District.

This agreement shall be binding upon the parties hereto and their successors. The persons executing this Agreement on behalf of the respective parties specifically acknowledge and represent that they have value authority to bind the party to whose benefit this Agreement had been executed.

Signatures:

District Board Representative



Servicing Agency Representative

Date

2-26-21

Date