

Board of Education Regular Meeting
Monday, June 12, 2023 7:00 PM
DC West High School Commons
401 South Pine Street
Valley, NE 68064-0378

1. Call to Order	
2. Public Communications and Correspondence	3
3. Approval of Agenda	
4. Administrative Reports	5
4.1. Superintendent's Report	30
4.2. Financial Report	32
5. Consent Agenda	
5.1. Approve Minutes	39
5.2. Approve Claims for Payment	
5.3. Approve Financial Report	
5.4. Approve Classified Staff	
6. Old Business	
6.1. Building and Grounds Update	
7. New Business	
7.1. Grading System Policy 5204 First Reading & Discussion	46
7.2. Approve Recommended Phone System Purchase	51
7.3. Consider, Discuss, and Approve the Repair or Replacement of RTU-7	85
7.4. Approve Replacement Purchase of Gas Convection Oven & Gas Range	96
7.5. FY24 Funding & Budget Preview and Discussion	

7.6. Approve Purchase of Replacement Passenger Vans

109

7.7. Authorize Treasurer to Process Claims for July 2023 in Absence of the July Board Meeting

8. **Adjournment**

Board of Education

Jamie Jorgensen

Bill Koile

Dr. Kelly Hinrichs

Elizabeth Mayer

Luke Janke

Jim Tomanek

Dr. Melissa Poloncic, Superintendent

Kristi Trost, Board Secretary

This pamphlet has been developed to help the general public attending a meeting of the Board of Education to understand the internal operation of the Board. It is hoped that this pamphlet will foster improved relations between the Board and the citizens it serves.

Meetings of the Board

When

- The Board of Education convenes once each month on the second Monday except in the months that have five Mondays. In months with five Mondays, the Board convenes on the third Monday of the month. Holidays and unexpected conflicts may create exceptions to this practice.
- The Board of Education will convene in special session whenever it is deemed necessary for the efficient operation of the school district.
- Board of Education meetings are called to order at 7:00 p.m. unless another time is stipulated.

Where

- Regular and special meetings of the Board of Education will be held in the Board Room on the Valley Campus at 401 S. Pine St., in Valley, unless another location is specifically identified.
- Whenever public participation dictates the need for a larger meeting room, the Board will convene in the High School library.

Notice of Meetings

- Official notice of the time and place of the regular board meetings are posted on the doors of the schools, banks in Valley and Waterloo, Valley City Hall and Waterloo Post Office.
- Notice of special meetings will be posted at least 24 hours in advance. Hearings will be published in the Douglas County Post-Gazette.

Business of the Board

Agendas

- Agendas for the regular meeting on the second Monday of the month will be prepared in advance and kept current and available in the superintendent's office. Business items of an emergency nature may be placed on the agenda by a majority vote of the Board of Education.
- Parents, employees and patrons may request items placed before the Board of Education for consideration by contacting the Superintendent at least three business days in advance of a regular meeting.

Public Participation

- The Board of Education invites you to offer comments during the Public Communication and Correspondence portion of the meeting. Public requesting to offer comments during the Public Communication portion of the meeting shall make a request to speak or complete the sign-in information sheet at the meeting. The individual is asked to state the purpose and general nature of his or her appearance before the Board. The Board President shall indicate to the individual how much time the Board will allot the individual. Speakers normally will be given five minutes with a maximum of 20 minutes set aside for such communications.
- Members of the public requesting to speak to an item considered New or Old Business on the Agenda will request time during the Public Communications portion of the meeting. Unless the comments are related to an agenda item no action will be taken by the Board. Questions or requests of the Board by the public will be taken under consideration. The Board will direct the Superintendent, or the Superintendent's designee, to respond in writing to any public

question or request brought before the Board. Equal time shall be allotted to individuals speaking for and against a proposal when opposing points of view are represented at the board meeting.

- The Board invites you to share any information you may have or address any question to any Board member or the Superintendent regarding new business in the week prior to the next meeting.
- If, at any Board meeting, any person shall conduct himself or herself in a disorderly manner and after notice of the president or the person presiding shall persist therein, the president or person presiding may ask the person to leave and if the person refuses, the president or presiding officer may order any law enforcement officer or any other person or persons to take him or her into custody until the meeting is adjourned.
- Meetings may be recorded. Recording must be done so as not to disrupt the meeting.
- Meetings of the Board of Education shall be conducted in compliance with appropriate policy, state statutes and open meeting laws.

Mission Statement

DC West Community Schools engages, prepares, and empowers all of our students for the future.



DC WEST
COMMUNITY SCHOOLS

www.dcwest.org

Board Meeting Procedures

“Engage, Prepare, and Empower”

The Douglas County West Community Schools does not discriminate on the basis of race, color, national origin, sex, disability, religion, age or other protected status in its programs and activities and provides equal access to the Boy Scouts and other designated youth groups. The following persons have been designated to handle inquiries regarding the non-discrimination policies:

Students: Superintendent of Schools, 401 S. Pine St., Valley, Nebraska 68064 (402-359-2583).

Employees and Others: Superintendent of Schools, 401 S. Pine St., Valley, Nebraska 68064 (402-359-2583).

Complaints or concerns involving discrimination or needs for accommodation or access should be addressed to the appropriate Coordinator. For further information about anti-discrimination laws and regulations, or to file a complaint of discrimination with the Office for Civil Rights in the U.S. Dept. of Education (OCR), please contact OCR at 8930 Ward Pkwy, Suite 2037, Kansas City, Missouri 64114, (816) 268-0550 (voice) or (877) 521-2172 (telecommunications device for the deaf) or ocr.kansascity@ed.gov.

**Douglas County West
Community Schools
P.O. Box 378
401 S. Pine St.
Valley, Nebraska 68064**



DC West Community Schools
Board Report June 2023
Dr. Dawn Marten - Director of Learning

Math Curriculum:

We kicked off the summer professional development series with all math teachers (including new teachers) receiving a full day math curriculum vendor training (Elementary: enVisions Math and Secondary: Reval Math). Teachers spent the day diving into the curriculum components and developing a K-12 math instructional vision for DCW. Teachers identified the teachers and student actions during math lessons. This will be the foundation to ensuring a vertical alignment across all K-12 grades. It will also assist principals with look-fors during instructional walk-throughs. Thanks to ESSER II funds, teachers will receive three additional days to plan with their team over the summer. Math topic/content internalization will be the focus throughout the 23.24 school year during PLC time. We will continue to expand our knowledge on research based math instructional practices and develop quartered plans based on the research. Teachers will bring student data to the PLC meetings to analyze for areas of strength and weaknesses then modify instructional practices based on that analysis.

ELA Curriculum:

At the beginning of June, all K-12 ELA teachers (including new teachers) participated in ELA curriculum training for the second year in a row. After one year of implementation with the Board approved curriculum, teachers had the opportunity to dive further into the components of the curriculum and continue to align lessons to the state standards. Teachers valued the time to collaborate and share ideas across the grade level vertical alignment. Again, thanks to ESSER II funds, teachers will also receive one additional day to plan with their team over the summer. We have such dedicated teachers.

NSCAS Data:

The state assessment, NSCAS, for Grades 3-8 was completed in Reading and Math and Science for Grades 5 & 8. The state is in the process of finalizing the data and creating reports over the summer. I will share our achievement data at the August Board Meeting and use eduClimber to demonstrate our areas of strength and opportunity. At that time, we will also analyze trend data along with a MAP data comparison.

Superintendent
Director of Learning
Director of Special Education
Elementary Principal
Middle School Principal
High School Principal
High School Assistant Principal/AD

Dr. Melissa Poloncic
Dr. Dawn Marten
Nicki Pechous
Dr. Jeffrey Kerns
Jeremy Travis
Jim Knott
Nathan Ter Beest

402.359.2583
402.359.2583
402.359.2583
402.359.2151
402.779.2646
402.359.2121
402.359.2121



May 2023

Dr. Jeffrey Kerns

DC West Elementary School Board Report

Thank you to the PTSA for sponsoring the END OF THE YEAR BASH! We had well over 350 families in attendance! Families enjoyed snow cones, bubbles, sidewalk chalk, multiple bounce houses, and a scavenger hunt!



Superintendent
Director of Learning
Director of Special Education
Elementary Principal
Middle School Principal
High School Principal
High School Assistant Principal/AD

Dr. Melissa Poloncic
Dr. Dawn Marten
Nicki Pechous
Dr. Jeffrey Kerns
Jeremy Travis
Jim Knott
Nathan Ter Beest

402.359.2583
402.359.2583
402.359.2583
402.359.2151
402.779.2646
402.359.2121
402.359.2121



DC WEST

COMMUNITY SCHOOLS

CREATING PASSIONATE LEARNERS

PO Box 378 • Valley, NE 68064 • www.dcwest.org • Ph: 402.359.2583 Fax: 402.359.4371

The HS Band and Choir came down to perform and answer questions about extra curricular opportunities to our 5th graders.



In late April Mayor Grove helped us celebrate Arbor Day! The Valley Tree board planted a tree that was donated to the school district from Lanoha Nurseries. Students from 4th grade sang the Arbor Day song with Ms. Beck.



Superintendent
Director of Learning
Director of Special Education
Elementary Principal
Middle School Principal
High School Principal
High School Assistant Principal/AD

Dr. Melissa Poloncic
Dr. Dawn Marten
Nicki Pechous
Dr. Jeffrey Kerns
Jeremy Travis
Jim Knott
Nathan Ter Beest

402.359.2583
402.359.2583
402.359.2583
402.359.2151
402.779.2646
402.359.2121
402.359.2121



DC WEST

COMMUNITY SCHOOLS

CREATING PASSIONATE LEARNERS

PO Box 378 • Valley, NE 68064 • www.dcwest.org • Ph: 402.359.2583 Fax: 402.359.4371

Battle of the Books: The team lead by Mrs. Brown placed 4th in the performance category and 7th in the writing category out of 22 teams! Well done Falcons!



We celebrated Career Day in late April. Thank you to the many presenters who took time to share their experiences and to teach our students about their profession!



Superintendent
Director of Learning
Director of Special Education
Elementary Principal
Middle School Principal
High School Principal
High School Assistant Principal/AD

Dr. Melissa Poloncic
Dr. Dawn Marten
Nicki Pechous
Dr. Jeffrey Kerns
Jeremy Travis
Jim Knott
Nathan Ter Beest

402.359.2583
402.359.2583
402.359.2583
402.359.2151
402.779.2646
402.359.2121
402.359.2121



DC WEST

COMMUNITY SCHOOLS

CREATING PASSIONATE LEARNERS

PO Box 378 • Valley, NE 68064 • www.dcwest.org • Ph: 402.359.2583 Fax: 402.359.4371

Our 5th Graders participated in track and field day with the MS staff and students!



Thank you to Mrs. Picht for organizing an outstanding track and field day for our K-4 Students! This year our 5th graders had the opportunity to participate and demonstrate leadership skills by helping run all of the events for our younger Falcons! Thank you to all of our families who came out to cheer their Falcons on!



Superintendent
Director of Learning
Director of Special Education
Elementary Principal
Middle School Principal
High School Principal
High School Assistant Principal/AD

Dr. Melissa Poloncic
Dr. Dawn Marten
Nickj Pechous
Dr. Jeffrey Kerns
Jeremy Travis
Jim Knott
Nathan Ter Beest

402.359.2583
402.359.2583
402.359.2583
402.359.2151
402.779.2646
402.359.2121
402.359.2121



DC WEST

COMMUNITY SCHOOLS

CREATING PASSIONATE LEARNERS

PO Box 378 • Valley, NE 68064 • www.dcwest.org • Ph: 402.359.2583 Fax: 402.359.4371

Meet Your Teachers Day: When the 5th graders transitioned to the MS for Step Up Day, our K-4 students had the opportunity to meet next year's grade level teachers. They visited their new grade level classrooms, learned about fun activities, and the learning opportunities that will take place next year!



We held a farewell breakfast for our 5th graders. Families were invited to join us as we watched a video celebrating each student's educational journey with us! Students then exited the building to a tunnel of families and friends cheering them on!



Director of Learning
Director of Special Education
Elementary Principal
Middle School Principal
High School Principal
High School Assistant Principal/AD

Dr. Dawn Marten
Nickj Pechous
Dr. Jeffrey Kerns
Jeremy Travis
Jim Knott
Nathan Ter Beest

402.359.2583
402.359.2583
402.359.2151
402.779.2646
402.359.2121
402.359.2121



DC WEST COMMUNITY SCHOOLS

CREATING PASSIONATE LEARNERS

PO Box 378 • Valley, NE 68064 • www.dcwest.org • Ph: 402.359.2583 Fax: 402.359.4371

Buffet Early Childhood Institute: Dr. Acklie and I were able to join teams of principals, home visitors, family facilitators, and community facilitators who were engaged in their community of practice that focused on learning from each other about building equitable family partnerships and developing early childhood family engagement practices.



Amy Ethen, Kelsey Nabity, Dr. Acklie, Dr. Marten, Nicki Pechos, and I attended the Superintendents Early Childhood Plan Action Plan Retreat. Dawn, Nicki, and I presented to members of the Learning Community Board, Buffet Early Childhood Institute, and other member schools. The later part of the afternoon was spent creating action plans for the 2023-2024 school year.



I had the opportunity to travel with leaders from the Buffet Early Childhood Institute to attend an AASA Leadership COHORT in Savannah. During this three day event educational leaders had the opportunity

Superintendent
Director of Learning
Director of Special Education
Elementary Principal
Middle School Principal
High School Principal
High School Assistant Principal/AD

Dr. Melissa Poloncic
Dr. Dawn Marten
Nicki Pechos
Dr. Jeffrey Kerns
Jeremy Travis
Jim Knott
Nathan Ter Beest

402.359.2583
402.359.2583
402.359.2583
402.359.2151
402.779.2646
402.359.2121
402.359.2121



DC WEST

COMMUNITY SCHOOLS

CREATING PASSIONATE LEARNERS

PO Box 378 • Valley, NE 68064 • www.dcwest.org • Ph: 402.359.2583 Fax: 402.359.4371

to examine how Savannah-Chatham County Public Schools support students and families with their extensive wrap-around services. We had the opportunity to engage in dialog on how their schools are ensuring their students receive academic programming and life-skill development skills.

Teacher leadership is the process by which teachers, individually or collectively, influence their colleagues, principals, and other members of the school communities to improve teaching and learning practices with the aim of increased student learning and achievement. Such team leadership work involves three intentional development: individual development, collaboration or team development, and organizational development

-The Center for Comprehensive School Reform and Improvement

On May 26th Elementary Staff Members participated K-5 EIA curriculum support work and the following week they participated in K-5 math curriculum support work with our director of learning and facilitators from ESU3 .



Superintendent
Director of Learning
Director of Special Education
Elementary Principal
Middle School Principal
High School Principal
High School Assistant Principal/AD

Dr. Melissa Poloncic
Dr. Dawn Marten
Nickj Pechous
Dr. Jeffrey Kerns
Jeremy Travis
Jim Knott
Nathan Ter Beest

402.359.2583
402.359.2583
402.359.2583
402.359.2151
402.779.2646
402.359.2121
402.359.2121



**Douglas County West
Middle School Board Report June 2023
Mr. Jeremy Travis**

Enrollment as of 6/7/23

6th-63

7th-91

8th-88

Total DC West Middle School (242)

Well, we got all moved out of our current Middle School on those last couple of days of school with taking the furniture (desks, chairs, tables) to the cafeteria as well as all of the teacher's classroom supplies and personal belongings to the library. It was a team effort from everyone that was organized and efficient. They started the demo work almost immediately after we exited the area and we can't wait for what that's going to be for our students and programs. Nikki Kingham (MS Secretary) and I are currently housing out of the Falcon Achievement Center for the summer.

DC West Middle School Summer School is underway from June 5th-June 22nd Monday thru Thursday from 8:30am-11:30am. Due to relocating, we are holding our Summer School in the High School Math wing. Our Summer School Teachers are Lindsey Pearson, Sherry Dill, and Taylor Siegrist.

Our **New Middle School Staff** have been rolling in this summer for some professional development opportunities in their curricular areas. They are also getting a chance to check out

Superintendent
Director of Learning
Director of Special Education
Elementary Principal
Middle School Principal
High School Principal
High School Assistant Principal/AD

Dr. Melissa Poloncic
Dr. Dawn Marten
Nicki Pechous
Dr. Jeffrey Kerns
Jeremy Travis
Jim Knott
Nathan Ter Beest

402.359.2583
402.359.2583
402.359.2583
402.359.2151
402.779.2646
402.359.2121
402.359.2121



PO Box 378 • Valley, NE 68064 • www.dcwest.org • Ph: 402.359.2583 Fax: 402.359.4371

their technology to get a head start on planning for the upcoming school year that will be here before we know it. We are really excited about the new staff being a part of our DC West family.

We sent three 7th grade students to the **PlaySmart Leadership Academy** on June 5th-June 8th at the Kroc Center in Omaha. They will have an opportunity to further their leadership skills at this academy. They will participate in the following:

Leadership Project-They will work with the other students from their school and design a literacy project that they will implement back at their school. Upon successful implementation they will receive a \$250 grant to give to their school.

Community Project-The students will be mixed with other students and will work with a teacher to develop a community project. They will be asked to present the community project on the last day.

Activities-The students will be doing a wide arrange of activities (team/sporting activities and maybe swimming) where they will learn leadership skills and how to work with others while accomplishing a task.

Speakers-Each day two speakers from the community speak to the kids about leadership. These have been impactful speakers for the students.

We have some Middle School Summer Staff Building Level work that our current and incoming staff will be collaborating on for this upcoming school year. We will be working on continuing to develop **The Falcon Way** at the Middle School and give a relook at our current practices, create a daily regiment for our teachers and students during their **Pride** time, and create a system for our daily **MTSS** class period for all grade levels for intervention, on grade level work, HAL, and enrichment opportunities. We have chosen some dates in June to work on these items.

The Middle School **Master Schedule** is set for the 2023-2024 school year. We have put a lot of thought and work into it. All of our students will take ELA, Math, Social Studies, and Science. They will have a PE/Art class that will alternate every day (2.5 days of each per week). They will have a Band/Choir class period and in 7th/8th grade if they don't take Band/Choir then they will have a Guided Study Hall at some time throughout their day. They will have Pride (Academic Advisory and The Falcon Way). They will have an MTSS period (intervention/support in ELA and Math, on grade level work in ELA and Math, HAL (ELA, Math, and Science), and enrichment (STEM). Lastly, each student will have a Specials Class period (6th grade-8th Hour: Health, STEM, Computers, Theatre, and Media Research. 7th grade-7th Hour: Health, STEM, French, Careers, and Digital Citizenship. 8th grade-4th Hour: Health, STEM, Spanish, FCS, and

Superintendent
Director of Learning
Director of Special Education
Elementary Principal
Middle School Principal
High School Principal
High School Assistant Principal/AD

Dr. Melissa Poloncic
Dr. Dawn Marten
Nick Pechous
Dr. Jeffrey Kerns
Jeremy Travis
Jim Knott
Nathan Ter Beest

402.359.2583
402.359.2583
402.359.2583
402.359.2151
402.779.2646
402.359.2121
402.359.2121



Strength & Conditioning. If a student takes Band or Choir then they will not have a Guided Study Hall throughout their school day. We have really taken a look at this schedule both administratively and with teachers and we believe that it provides a good progression balance in classes as well as opportunities to learn and explore for our students throughout their day. Our teachers are looking forward to it!

We had a great celebration for Debbie Finnicum's **Retirement**. We also wished the best to Jenny Wright and Sara Horstman as they move on to their next professional life adventure. They all made positive contributions to our students, staff, and families at DC West Middle School.

We will continue to develop what **The Falcon Way** looks like at our Middle School. We will continue to focus on Falcons being Safe, Responsible, Respectful, Engaged, and Inclusive for us! We will continue to have daily, weekly, monthly, and quarterly student incentives for our students throughout the school year.

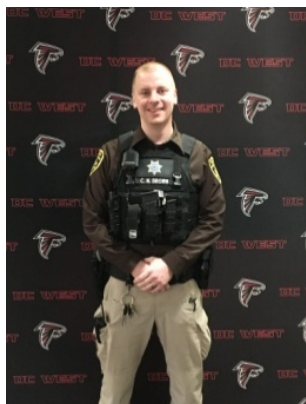

Deputy Brown-School Resource Office (SRO) Update:

Deputy Brown is continuing to update our District and Building Level Safety Plans and Procedures for the upcoming school year. Deputy Brown continues to keep current in all of his trainings as a School Resource Officer and Deputy.

We are determined to continue to provide a safe and positive learning environment for all students and staff. Please feel free to contact me if you have any questions, if you want to see how things are going throughout the day, or if you have any concerns. I'm proud of what we do and who we are! Go Falcons!

Jeremy Travis, M.A.

Douglas County WEST FALCONS

Middle School Principal/AD (6-8)

Superintendent
Director of Learning
Director of Special Education
Elementary Principal
Middle School Principal
High School Principal
High School Assistant Principal/AD

Dr. Melissa Poloncic
Dr. Dawn Marten
Nick Pechous
Dr. Jeffrey Kerns
Jeremy Travis
Jim Knott
Nathan Ter Beest

402.359.2583
402.359.2583
402.359.2583
402.359.2151
402.779.2646
402.359.2121
402.359.2121



DC WEST

COMMUNITY SCHOOLS

CREATING PASSIONATE LEARNERS

PO Box 378 • Valley, NE 68064 • www.dcwest.org • Ph: 402.359.2583 Fax: 402.359.4371

School Phone: [402.779.2646](tel:402.779.2646)

Cell Phone: [402.616.9718](tel:402.616.9718)

Fax Number: [402.779.2534](tel:402.779.2534)

"Kids don't care how much you know until they know how much you care"

#TheFalconWay #FalconStrong #DCWestROCKS #BeFALCONKind

LOVEYourPEOPLE

Superintendent
Director of Learning
Director of Special Education
Elementary Principal
Middle School Principal
High School Principal
High School Assistant Principal/AD

Dr. Melissa Poloncic
Dr. Dawn Marten
Nick Pechous
Dr. Jeffrey Kerns
Jeremy Travis
Jim Knott
Nathan Ter Beest

402.359.2583
402.359.2583
402.359.2583
402.359.2151
402.779.2646
402.359.2121
402.359.2121



Janna Giles **Middle School Math Interventionist**

Good afternoon Mr. Travis and DC West Middle School Staff!

My name is Janna Giles and I am currently a 5th grade teacher at DC West Elementary School. This is my 3rd year in the district. My previous experience includes working in 3rd and 6th grade. I received my Bachelor's from UNL in 2011 and my Masters in Curriculum and Instruction with a Math Emphasis from Concordia in 2016. My husband Spencer and I have three kids, all who go to school at DC West; Darby is a Junior, Joslyn is a Freshman, and Emmett is a 6th grader. We have lived in Valley for almost 4 years and absolutely love the community and school district. In my free time, I enjoy reading, spending time on the water, and bowling. I am so very excited to be a member of the DC West Middle School and can't wait to get to know everyone!!!



Sara Gotch **Middle School Art**

I have currently been teaching for OPS for 14 years at Alice Buffet Middle School. I received my Bachelor's Degree in K-12 Art Education at Wayne State College in 2008. My family and I currently live in Ashland but will be moving to Valley in the late fall. We have 2 kids, Wyatt is currently a 4th grader and Brinley is finishing up pre-school. I love art, photography, traveling, and hanging out with friends. I'm excited to be at DC West with you all!



Beau Schwenka 7th Grade Science

Hello everyone,

My name is Beau Schwenka. My wife, Natalie, and I have been married 2 years and we have two golden retrievers. Finn is the big one and Denali is the little one (not so little anymore). I will bring pieces of them with me everywhere I go, no matter how hard I try not to. I've spent the last 8 years at Westside High School. 2 of them were at the alternative high school (West Campus) and 6 at the main high school. I'm a big sports fan and will always be a Husker optimist on week 1 of every new season. I'm usually over that by week 3. My wife and I enjoy being active, outdoors, and cooking. We are looking forward joining the DC West community and getting to know everyone!



Adelaide (Ady) Watts 7th Grade Social Studies

Hi everyone! My name is Adelaide Watts but please call me Ady, I am a first year teacher, I recently graduated from Northwest Missouri State University in Maryville, Missouri. I was fortunate enough to play collegiate softball all my years there. I am huge sports fan, Huskers of course, but I also love the Royals and the Dallas Cowboys. I was born and raised in Gretna and grew up being the oldest of 3, my brother is going to college and my sister is a senior at Yutan High. I spend a majority of summer coaching softball with my dad for our summer softball team, but when I am not on the field I love to cook and bake new recipes. If you have any please send them my way! I look forward to meeting and working with everyone!



Kathleen (Katie) Richards Middle School Guidance Counselor

Hello! I am Katie Richards and I am very excited to serve as the School Counselor at DC West Middle School this upcoming year! For the past 4 years, I have been teaching Family and Consumer Sciences at Giltner Public School. I am originally from Ashland, so I am eager to head back east to be closer to home and family. When I'm not at school, you can find me running with my dog Loki or baking up some treats. I am looking forward to meeting and learning about the staff, students, and community at DC West! Go Falcons!



Jacob (JD) Gagner Middle School STEM

Hi! My name is Jacob Gagner but most people call me JD. I was born and raised in Sitka, Alaska which is a small town in the Southeast portion of the state. Growing up, I spent most of my time hunting, fishing, and playing as many sports as I could. Once I graduated, I accepted a swimming scholarship and moved to Fremont. While I was at Midland University, I studied math education and eventually picked up a mathematics major. In November of this year, I applied for the assistant wrestling coaching job at DC West High School. I enjoyed working with the students and staff as a wrestling coach and requested to switch my student teaching to DC West. I have been working closely with Ms. Cox and Ms. Pearson during my final semester of college. I spend my summers commercially fishing for sockeye salmon in Bristol Bay, Alaska. I am extremely excited to teach STEM at DC West middle school next August and continue coaching. Due to my student teaching and coaching I have already begun building relationships with the staff and the student body. I can't wait to continue these relationships and tackle the challenges of being a first year teacher in the fall.

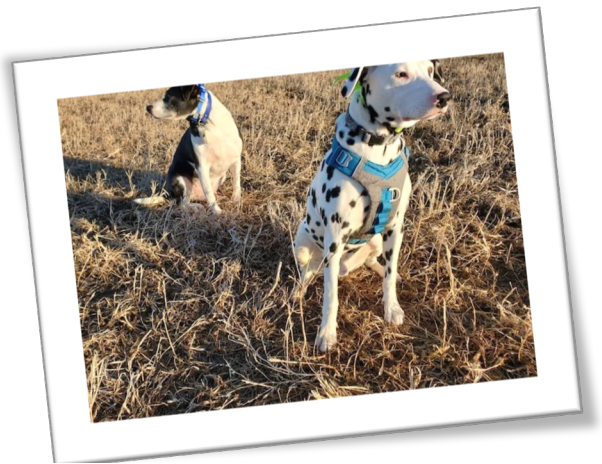

Traci Evans 8th Grade Math Teacher

Hello! My name is Traci Evans and I will be teaching 8th Grade Math at DC West next year. I have spent the last 11 years teaching for Omaha Public Schools at both the elementary and middle school level. I received my Master's in Educational Administration in 2014 from Concordia University and my Master's in Teaching Mathematics from UNL in 2016. My husband, Scott, and I live in Omaha with our 4-year-old daughter Ellie and our two dogs Biker (rescue mutt) and our puppy, Norman (Dalmatian). In our free time, we enjoy anything that has to do with being outdoors and working on renovating our home. I am very excited to join DC West Middle School next year and am looking forward to working with everyone!



Jesse Hays

6th Grade Math Teacher

I am happy to be back teaching at the place where I got my start. I taught 5th and 6th grade Science at DCW from 2005-2009. Since then, I have been all over the grid. I spent four years in Dearborn, MI. where I spent time raising my daughter, Maya, substitute teaching, and coaching football. The next move was to Scottsbluff where I taught 5th grade Math, Reading, and Science. Until recently, I lived in Beatrice where I was a personal trainer. Now I'm happy to be back in the metro, and I'm looking forward to teaching 6th grade Math. My hobbies include running, working out, watching sports, reading, hiking, and making dash cam videos of towns in Nebraska. I look forward to teaching with all of you!



June 2023 Board Report

It is always interesting when the students and staff leave for the summer. The school gets a little quieter and often times, Jim and I find ourselves talking about the past year. It was a whirlwind of a year for sure. There have been so many accomplishments and examples of tremendous growth that have happened. Many of the sport programs are starting to show on a different level the work athletes and coaches have put in. I would say looking to the future, I am excited to see what will be accomplished.

One of the cool things that is currently going on is that our summer weights program has started. I spoke to Adam Loftis, who is the lead on the summer program, and he said there are somewhere between 130 and 140 high school students who have come to lift at one of the 5 assigned times. He has also had a strong showing in his middle school session of student athletes who are looking to get a jump on their strength gains. The summer lifting program is a key element to athletic success for our programs. Our athletes have bought into the weight room and their gains can clearly be seen. Aside from the weight room, all of the sports are engaging in camps, open gyms, 7 on 7, and so on. There is definitely a desire to compete from our students and as we build a culture of winning at DC West, we need to keep the desire alive for each of these athletes. I am a firm believer that if you take care of the little things in athletics, they will yield great results. The athletes and coaches are working hard on the little things and the great yields will be seen in the upcoming season.

It has been a great 2022-2023 school year and after a brief period of rest....bring on 2023-2024!!





Jim Knott

High School Board Report

High School Principal

June 12, 2023

The school year wound to a close for students with final exams on May 22-24. Most teachers finished up on that Friday. Since that time, we have gone into “summer mode” which includes updating handbook policies, preparing and supervising summer school, administrative meetings, and generally planning for the 2023/24 school year. It is also a time of excitement as we are able to see the new middle and high school facilities getting closer to a reality. It will be great having more space next year!

Our summer school session at the high school began on Monday, June 5 and will run through Friday, June 23. The program includes 15 sessions from 8-11 in the morning. Students who need credit recovery are invited and must attend a minimum of 12 sessions. Ron Michael, Heather Cox, and Trey Baker are again coordinating and teaching this year’s summer school. Our program is available only to DC West students and the cost is \$100. We have 16 high school students attending. High School Counselor Ron Michael stated, “Our numbers in summer school and in the Falcon Achievement Center are down a bit compared to past years. I attribute this to hard work by teachers and students as well as all the supports that have been added to the high school over the last 5 years. Simply put, more students are passing more classes, which means fewer students are needing summer school and alternative education.”

For various reasons, we have not been able to hire a quality, full-time Spanish teacher for next year to replace Mrs. Ramirez. I wanted to give you a brief update on how we are planning on covering our World Language needs next year. First, we have hired a high-quality half-time Spanish teacher for next year. Her name is Gisele Daigle and is a retired Spanish and French teacher from Elkhorn. She has worked for us in the past as a long-term substitute in the World Language Department. Mrs. Daigle will teach two sections of Spanish II, one section of Spanish III, and one section of Spanish IV. District EL teacher, Alyssa Lindahl will teach two sections of Spanish I and will spend the remainder of the day teaching PK-12 EL. New French teacher, Lisa Benson will teach all the high school French classes as well as 7th grade French and 8th grade Spanish. We feel fortunate to have been able to hire Mrs. Daigle for next year and plan to advertise starting in January in order to hire a full-time Spanish teacher for the 2024/25 school year.

Superintendent
Director of Learning
Director of Special Education
Elementary Principal
Middle School Principal
High School Principal
High School Assistant Principal/AD

Dr. Melissa Poloncic
Dr. Dawn Marten
Nicki Pechous
Dr. Jeffrey Kerns
Jeremy Travis
Jim Knott
Nathan Ter Beest

402.359.2583
402.359.2583
402.359.2583
402.359.2151
402.779.2646
402.359.2121
402.359.2121



June 2023 Special Education Report

Hello! I hope you are all enjoying a great start to summer! The Special Education Department has been busy this month with finishing out the school year, planning for summer programming for students and professional development for teachers, and analyzing data for year-end reports and improvement planning purposes. June will be a very busy month, and then we hope to take some time in July to recharge before starting the 2023-24 school year.

DC West NECounts Determination and Performance Report

NDE makes an annual determination on the performance of each district on their compliance to federal special education statute (i.e. IDEA) and the outcomes of students ages 3-21 receiving special education services. This information is reported publicly on the NEP website effective June 1.

In analyzing our Determination Report, I am happy to report that our determination was “Meets Requirements.” Areas of strength in which we were categorized as showing no risk for not meeting requirements included the following:

- *Indicators relating to Equity:*
 - No significant discrepancies in our rates of identification for special education services among diverse populations.
 - No disproportionate rates of disciplinary action for any specific group.

- *Indicators relating to Compliance:*
 - Prompt completion of initial evaluations within appropriate timelines.
 - Prompt transition of toddlers to preschool services.
 - Timely correction of any areas of noncompliance.
 - Submission of timely and accurate data to the State.
 - No State Complaints
 - Acceptable maintenance of financial efforts for specialized programming.

- *Indicators Related to Placement:*
 - High rates of preschoolers with disabilities receiving special education services within the regular early childhood program.

- *Indicators relating to Outcomes:*
 - High graduation rates.
 - Low drop out rates.



- Improved outcomes for preschoolers after participation in our preschool.

Our only area of high risk on our Determination report was related to School-Aged Least Restrictive Environment. This indicator looks at how many of our students with disabilities receive their special education services in the regular classroom for at least 80% of the day. Although we did not meet this target, we were very close to meeting it in two of three areas. The first goal was 81% of students in the general classroom for 80% of the day, and we were at 80%. The second goal was 5.44% or less students in regular classes for less than 40% of the day; our percentage was 6%. The third goal is 2.25% or less of students in separate schools, residential facilities, or hospitalized/homebound. Our percentage is 5%. This is an area we will work to reduce over time through increased behavioral supports, mental health supports, training on inclusive practices and effective IEP writing, and post-secondary transition programming.

Get SET Nebraska Special Education Teacher Retention Project

We will continue our participation as a pilot district for NDE’s special education teacher retention project, “Get SET Nebraska.” This project aims to support new special education teachers in order to retain them in their positions throughout their first year, as the high rates of attrition for special education teachers is contributing to the extreme teacher shortage in this area.

Last year, Megan Nolasco was our target mentee in the program, with Jake Subbert serving as her mentor, and I was the administrative representative on the team. Throughout the year, Jake and Megan worked through a structured process to ensure that Megan was fully prepared as a new special education teacher in the district, and I completed a Administrative Leadership Academy to ensure that I knew how to best support Megan as a new teacher. The good news is that we retained her! Megan has been a great addition to our staff, and we are thrilled to have her with us again for next year.

As a pilot district, we are automatically accepted into the program for 2023-24. This year’s participants will be Cassie Seckel, Elementary Special Education, with Jake Subbert again serving as mentor. Kelsey Nabity, our new district Mentor Coordinator, will serve as the Administrative Representative for the district.

Updated District Specific Learning Disability Eligibility Guidance

Kristen Phillips and Reagan Rosenberg, School Psychologists, and I worked throughout the year to develop an updated district special education process for evaluating students for learning disabilities. Our new process is aligned with NDE’s Eligibility Guidelines and no longer focuses on a discrepancy between a student’s IQ and their achievement in a specific academic skill area as the basis for determining a student as having a learning disability and being eligible for special education services.

Superintendent
 Director of Learning
 Director of Special Education
 Elementary Principal
 Middle School Principal
 High School Principal
 High School Assistant Principal/AD

Dr. Melissa Poloncic
 Dr. Dawn Marten
 Nicki Pechous
 Dr. Jeffrey Kerns
 Jeremy Travis
 Jim Knott
 Nathan Ter Beest

402.359.2583
 402.359.2583
 402.359.2583
 402.359.2151
 402.779.2646
 402.359.2121
 402.359.2121



The new process provides structure and guidance for teams to identify students as IEP-eligible when they meet certain criteria primarily related to the student not making progress and meeting grade-level standards even when provided adequate instruction and research-based intervention. This process is grounded in research and best practices and replaces the “discrepancy formula,” which lacks research support for further use.

SRS Advisory Council

I will be joining the SRS Advisory Board this year as the Region 2 Representative. SRS is a special education recordkeeping system designed for Nebraska and managed by our ESUs and the SRS Advisory Board. Participating on this committee will allow us to have input on how our special education forms are worded and designed to best meet the needs of our students and teachers while also maintaining compliance with federal and state guidelines.

Unique Learning Curriculum

Unique Learning System is a curriculum designed specifically to help students with special learning needs master their state's extended standards. We have been using Unique at the elementary level for our students who participate in alternate curriculum and assessment, and we started using Unique at the middle level this past year. We are excited to be bringing Unique to the high school level with a focus on vocational skills and independent living this year. In addition, Nick Sims, Lisa Masters, and Cassie Seckel will have the opportunity to be trained in the curriculum at ESU 3 this summer, so they will be ready to use this new tool with students this fall.

Thank you as always for your continued support. See you next month!

Nicki Pechous, Ed.S.
Director of Special Education

Superintendent
Director of Learning
Director of Special Education
Elementary Principal
Middle School Principal
High School Principal
High School Assistant Principal/AD

Dr. Melissa Poloncic
Dr. Dawn Marten
Nicki Pechous
Dr. Jeffrey Kerns
Jeremy Travis
Jim Knott
Nathan Ter Beest

402.359.2583
402.359.2583
402.359.2583
402.359.2151
402.779.2646
402.359.2121
402.359.2121

Superintendent's Report June 12, 2023

Teacher Retention

This year we had three teachers attend the Metropolitan Omaha Education Ambassadors Program. The program was developed out of a grant opportunity to bring individual teachers from various backgrounds and districts together and connect educators with unique viewpoints to deepen awareness, increase knowledge, and strengthen leadership skills with a goal of elevating the teaching profession.

As a part of this process, the three ambassadors sent out a couple of DC West staff surveys related to our teacher's perceptions as an educator as well as how we spend our time in professional development, PLCs, and plan time.

The three ambassadors presented both of the survey results with our administrative team. The administrative team reflected and had deep discussions related to the responses and we're making plans for future action. We also met with the three ambassadors who assisted in developing ideas for our future plans. Here are some next steps we want to explore next year:

- The creation of a Teacher Leaders Advisory that will meet for a quarterly luncheon where solution focused teachers meet and discuss barriers in the teaching profession. A couple of members of this advisory will then take this information to district and building administration in order to share information with a solutions focus.
- We're also hoping that this advisory would assist in engaging administration and staff in implementing ideas to support a healthy school culture.
- The ambassadors and administration really liked the article: [The Power of Doing Less in Schools](#). We hope that this may be the basis of conversation with all of us early on next year.
- Ideas for change in the teacher contract that may assist in teacher retention discovered during exit interviews.
- Consider giving teachers the option to work from home or school on the October, January, and March teacher workdays.

We are dedicated to working collaboratively in order to enhance our district's professional culture. We will continue to work together with our teachers on other ideas as retention of teachers is a nationwide issue.

Safety Plan

Eight members of our crisis planning team will be attending a two day training from the Nebraska Department of Education, [The Nebraska School Safety Emergency Operations Planning Training](#), in June. We will be reviewing and revising our school district safety plan. The newly revised plan, a result of the training, will be shared with the BOE in August.

Handbooks & Fees

Principals are working on updating their student and staff handbooks for the 2023-2024 school year. Those handbooks will be presented to the BOE in the August meeting. Annually, the BOE conducts the fee hearing, reviews and adopts the fees policy for the year. This will take place in August.

Assistant Activities Director Extra Duty

Due to considerable growth in our extra curricular programs at DC West, the administration is exploring the proposal of a new extra duty position to assist the middle and high school administrators and programs. I will be meeting with our DCWEA officers for a discussion regarding this position in the coming days. We will likely present this position to the Board for their

consideration in August so that we may fill the position for the 2023-2024 school year. At this time, the description of the extra duty position would include:

- Assisting the ADs with home game set-up
- Assisting the ADs with scheduling away contest transportation
- Cross-checking schedules & calendar for events and facilities
- Coordinating social media posts to balance program coverage
- Assist with eligibility lists and follow-up
- Assist with concession ordering
- Assist with supervision at events

Superintendent Goals for 2023

- Lead the vision and support needed to implement strategic plan priorities.
- Refine our Multi-Tiered System of Supports (MTSS) model to support academic achievement and provide social-emotional behavioral supports for all students PreK-12.
- Engage in financial planning and design for long-term capital improvement projects.
- Complete the pilot and adoption process of a new certified staff and administrator evaluation system as well as implement new electronic management for personnel evaluation.
- Continue to learn strategies to facilitate, coach and lead the entire administrative team to excellence.
- Research, study, and implement strategies to manage the growth of the communities and district in the next five to ten years so we are proactive rather than reactive.

Upcoming Dates:

June 21st~ 7:00 pm, Valley Community Needs Assessment Results Town Hall at YMCA

July 3-7~ Melissa Vacation

July 16-19~ Melissa at Women's Leadership Conference, Austin TX

July 25-28~ Administrative Team at Administrator Days Conference in Kearney, NE

August 14~ Regular Board of Education Meeting

Financial Recap May 2023

	5/1/2023	Receipts	Expenditures	5/31/2023
General Fund	\$8,344,405.38	\$1,370,578.39	\$1,107,937.66	\$8,607,046.11
Depreciation Fund	\$2,176,869.29	\$2,312.24	\$0.00	\$2,179,181.53
Food Service Fund	\$207,350.22	\$75,084.31	\$68,651.10	\$213,783.43
Qualified Capital Fund	\$281,651.38	\$44,139.35	\$3,951.25	\$321,839.48
Bond Fund	\$892,900.50	\$103,618.77	\$296,475.00	\$700,044.27
Special Building Fund	\$2,006,756.61	\$205,796.73	\$0.00	\$2,212,553.34
- Special Bldg (MS/Fine Art)	\$3,256,617.44	\$0.00	\$592,552.86	\$2,664,064.58
	\$17,166,550.82	\$1,801,529.79	\$2,069,567.87	\$16,898,512.74

General Fund Detail

	May	YTD	Budgeted
Expenditures			
All Instructional Program	\$ 513,274.01	\$ 4,888,065.73	\$ 7,365,638.00
SPED Instructional Program	\$ 143,270.38	\$ 1,385,640.47	\$ 2,016,700.00
Support Services SPED Related	\$ 20,885.52	\$ 192,559.99	\$ 324,265.00
Support Services Non-SPED Related	\$ 26,453.42	\$ 260,214.76	\$ 302,340.00
Support Instructional	\$ 49,335.07	\$ 554,976.77	\$ 740,685.00
Board of Education	\$ 6,015.31	\$ 55,367.15	\$ 77,250.00
Executive Administration Services	\$ 26,080.97	\$ 336,985.41	\$ 427,969.00
District Legal Services	\$ -	\$ 4,792.25	\$ 35,000.00
Office of the Principal	\$ 61,032.66	\$ 593,356.81	\$ 790,732.00
General Admin - Business Services	\$ 26,705.14	\$ 198,495.43	\$ 249,300.00
Maint & Operation of Building & Sit	\$ 136,239.46	\$ 1,159,882.33	\$ 3,154,786.00
Vehicle Acquisition & Maint	\$ -	\$ 3,550.00	\$ 17,500.00
Regular Pupil Transportation	\$ 20,459.73	\$ 349,846.59	\$ 426,600.00
SPED Pupil Transportation	\$ 2,942.73	\$ 91,185.49	\$ 149,550.00
Categorical Grant from Coporation	\$ 7,816.64	\$ 73,389.66	\$ 128,660.00
State Categorical Programs	\$ 602.36	\$ 5,421.24	\$ 108,091.00
Federal Programs	\$ 34,233.46	\$ 305,921.10	\$ 408,894.00
ESSER II & III	\$ 32,590.80	\$ 88,234.21	\$ 791,000.00
	\$ 1,107,937.66	\$ 10,547,885.39	\$ 17,514,960.00

May 2023 Payroll

Net Payroll	\$ 502,731.90
Payroll Taxes (District)	\$ 54,343.36
Payroll Withholding (Employees)	\$ 128,701.94
Retirement (District)	\$ 69,216.12
Retirement Withholding (Employees)	\$ 68,530.78

	May	Revenues	YTD
Personal and Prop Taxes	\$ 730,335.85		\$ 6,774,063.04
Carline Tax	\$ 6,018.35		\$ 7,407.10
Motor Vehicle Taxes	\$ 105,262.28		\$ 933,977.82
Facility Rental	\$ -		\$ 250.00
Tuition Received from Individuals	\$ 2,690.10		\$ 96,668.06
Interest	\$ 4,870.18		\$ 17,606.03
Local License Fees	\$ -		\$ 1,875.00
Other Local Receipts	\$ 70.00		\$ 9,285.37
Grants from Corporations/Private	\$ -		\$ 49,770.46
County Fines and License Fees	\$ 2,032.94		\$ 15,499.98
ESU Receipts	\$ -		\$ -
State Aid	\$ 106,130.00		\$ 955,498.00
Special Education Programs	\$ 103,833.00		\$ 464,811.00
Special Education Transportation	\$ 35,722.00		\$ 35,722.00
Homestead Exemption	\$ 22,628.65		\$ 67,885.95
Pro-Rate Motor Vehicle	\$ -		\$ 15,634.45
High Ability Learners	\$ -		\$ 8,789.00
Early Childhood Grant	\$ -		\$ -
State Apportionment	\$ -		\$ 165,260.39
Other State Receipts	\$ -		\$ 5,104.56
Prop & Personal Property Tax Credit	\$ 243,807.41		\$ 491,304.04
Title ESSA Programs	\$ -		\$ 134,013.00
IDEA Programs	\$ -		\$ 335,788.00
Medicaid	\$ 6,502.63		\$ 13,182.85
ESSER II & ESSER III	\$ -		\$ -
Other Federal Categorical Receipts	\$ -		\$ 42,302.38
Sale of Property	\$ 675.00		\$ 2,840.00
Insurance Adjustment	\$ -		\$ 17,488.00
	\$ 1,370,578.39		\$ 10,662,026.48

Regular; Beginning Month 05/2023; Processing Month 05/2023; Accounts to Include Accounts with Activity; Fund Number 05, 12

Fund: 05 ACTIVITY FUND									
Chart of Account Number	Chart of Account Description	Beginning Balance	Expenses	Revenues	Balance Change	Balance			
05 704	INTEREST	923.20	0.00	88.13	0.00	1,011.33			
05 704 1001	ACTIVITY PASSES	5,331.14	0.00	0.00	0.00	5,331.14			
05 704 1002	CORPORATE SPONSORSHIPS	10,018.99	10,000.00	0.00	0.00	18.99			
05 704 1003	INSTRUMENTAL MUSIC	2,503.67	0.00	1,475.50	0.00	3,979.17			
05 704 1005	STAFF LOUNGE	1,620.69	0.00	48.32	0.00	1,669.01			
05 704 1006	STUDENT FINES	242.00	0.00	331.50	0.00	573.50			
05 704 1007	VALLEY WAY	13,576.40	0.00	0.00	0.00	13,576.40			
05 704 1008	DUAL CREDIT FEES	4,300.00	0.00	0.00	0.00	4,300.00			
05 704 1011	PTSA DONATION	4,117.70	0.00	0.00	0.00	4,117.70			
05 704 1022	SENIOR CLASS	191.62	0.00	0.00	0.00	191.62			
05 704 1023	PROM	3,468.73	0.00	0.00	0.00	3,468.73			
05 704 1102	ARTS & HUMANITIES	1,038.26	143.76	0.00	0.00	894.50			
05 704 1104	ATHLETICS HS	6,048.28	5,729.06	1,705.00	0.00	2,024.22			
05 704 1106	BASEBALL TEAM	1,985.48	0.00	0.00	0.00	1,985.48			
05 704 1107	BAND	4,811.58	0.00	0.00	0.00	4,811.58			
05 704 1108	CHEER	4,338.45	9,792.01	199.00	0.00	(5,254.56)			
05 704 1111	BBB TEAM	1,441.75	2,525.83	2,160.00	0.00	1,075.92			
05 704 1112	CONCESSIONS	27,777.59	205.92	868.50	0.00	28,440.17			
05 704 1113	CONSTRUCTION TECH	7,106.79	0.00	0.00	0.00	7,106.79			
05 704 1114	DANCE TEAM	705.88	0.00	0.00	0.00	705.88			
05 704 1116	DRAMA	5,271.84	0.00	20.00	0.00	5,291.84			
05 704 1117	FBLA	1,988.72	0.00	0.00	0.00	1,988.72			
05 704 1118	HIGH SCHOOL	259.12	0.00	350.00	0.00	609.12			
05 704 1119	DC TECH 1:1	42,281.23	0.00	1,540.00	0.00	43,821.23			
05 704 1120	GBB TEAM	5,602.58	0.00	735.00	0.00	6,337.58			
05 704 1123	HOSA	3,323.92	0.00	0.00	0.00	3,323.92			
05 704 1124	STUCO HS	2,507.70	583.54	0.00	0.00	1,924.16			
05 704 1128	NATIONAL HONOR SOCIETY	1,816.98	0.00	108.00	0.00	1,924.98			
05 704 1131	FOOTBALL TEAM	329.22	0.00	305.00	0.00	634.22			
05 704 1132	SCIENCE CLUB	206.19	0.00	92.00	0.00	298.19			
05 704 1133	SPEECH TEAM	2,082.44	0.00	80.00	0.00	2,162.44			
05 704 1134	VOCAL MUSIC	3,471.39	0.00	0.00	0.00	3,471.39			
05 704 1136	WORLD LANGUAGE CLUB	69.52	0.00	0.00	0.00	69.52			
05 704 1137	ROBOTICS TEAM	5,238.40	0.00	0.00	0.00	5,238.40			
05 704 1141	GOLF TEAM	84.88	0.00	0.00	0.00	84.88			
05 704 1142	YEARBOOK HS	4,689.35	0.00	0.00	0.00	4,689.35			

Regular; Beginning Month 05/2023; Processing Month 05/2023; Accounts to Include Accounts with Activity; Fund Number 05, 12

Fund: 05 ACTIVITY FUND									
Chart of Account Number	Chart of Account Description	Beginning Balance	Expenses	Revenues	Balance Change	Balance			
05 704 1151	CROSS COUNTRY TEAM	1,725.13	0.00	0.00	0.00	1,725.13			
05 704 1161	SOFTBALL TEAM	2,663.30	0.00	0.00	0.00	2,663.30			
05 704 1166	BOYS TRACK TEAM	381.33	0.00	0.00	0.00	381.33			
05 704 1167	GIRLS TRACK TEAM	674.39	0.00	0.00	0.00	674.39			
05 704 1176	VOLLEYBALL TEAM	2,963.64	1,119.00	2,624.00	0.00	4,468.64			
05 704 1186	WRESTLING TEAM	1,024.95	0.00	0.00	0.00	1,024.95			
05 704 1198	SUMMER SPORTS CAMPS	598.12	0.00	0.00	0.00	598.12			
05 704 1199	CHANGE BAGS	80.00	0.00	800.00	0.00	880.00			
05 704 1222	SCIENCE GRANT	3,055.68	0.00	0.00	0.00	3,055.68			
05 704 1224	STUCO MS	12,141.28	0.00	289.50	0.00	12,430.78			
05 704 1225	COFFEE CART - EL SPED	1,494.61	0.00	0.00	0.00	1,494.61			
05 704 1319	DISNEY MUSICAL	13,879.62	0.00	0.00	0.00	13,879.62			
05 704 1320	PRESCHOOL	45.33	0.00	0.00	0.00	45.33			
05 704 2112	MS CONCESSIONS	3,248.91	360.00	0.00	0.00	2,888.91			
05 704 2121	MS BBB TEAM	211.05	0.00	0.00	0.00	211.05			
05 704 2136	MS FOOTBALL TEAM	368.47	0.00	0.00	0.00	368.47			
05 704 2204	ATHLETICS MS	(646.50)	307.50	0.00	0.00	(954.00)			
05 704 2205	UNIFIED SPORTS	611.00	81.93	250.00	0.00	779.07			
05 704 2218	MIDDLE SCHOOL	1,077.62	40.00	1,080.00	0.00	2,117.62			
05 704 2242	MS YEARBOOK	3,524.84	0.00	115.00	0.00	3,639.84			
05 704 3220	ELEM FIELD TRIP	180.52	655.50	1,214.90	0.00	739.92			
05 704 3221	PBIS/FALCOIN	1,641.40	0.00	580.88	0.00	2,222.28			
05 704 3318	ELEMENTARY	4,060.11	375.00	722.00	0.00	4,407.11			
Fund Total: 05		235,776.48	31,919.05	17,782.23	0.00	221,639.66			

Regular; Beginning Month 05/2023; Processing Month 05/2023; Accounts to Include Accounts with Activity; Fund Number 05, 12

<u>Chart of Account Number</u>	<u>Chart of Account Description</u>	<u>Beginning Balance</u>	<u>Expenses</u>	<u>Revenues</u>	<u>Balance Change</u>	<u>Balance</u>
12 704	STUDENT PARTICIPATION FEE	12,721.88	0.00	0.00	0.00	12,721.88
Fund Total: 12		12,721.88	0.00	0.00	0.00	12,721.88

Fund: 12 STUDENT FEES

06/07/2023 05:05 PM

JUNE 2023 BOARD BILLS

User ID: CQ

Vendor Name	Vendor Description	Amount
Checking Account ID 1	Fund Number 01 GENERAL FUND	
AKRS EQUIPMENT SOLUTIONS INC		79.99
AMAZON CAPITAL SERVICES		1,934.03
APPLE COMPUTER INC		5,954.00
ARROW STAGE LINES		1,574.00
ASPI SOLUTIONS INC		96.00
AWARDS UNLIMITED INC		137.46
BOOKWORM, INC, THE		43.95
BORDER STATES INDUSTRIES INC		378.00
BSN SPORTS INC		778.29
CAPPEL NAPA AUTO SUPPLY - VALLEY		56.96
CINTAS CORP		187.80
CITY OF VALLEY		2,433.08
DAILY RECORD, THE		309.52
DC WEST FOOD SERVICE		1,089.40
DIETZE MUSIC HOUSE		191.00
EDUCATIONAL SERVICE UNIT #3		10,080.00
EGAN SUPPLY CO		1,116.96
FIRST STUDENT		37,155.29
HOMETOWN LEASING		2,522.27
JOSTENS INC		13.70
JW PEPPER & SONS		472.63
MARKING REFRIGERATION		309.75
MENARDS - ELKHORN		588.14
METAL DOORS & HARDWARE CO		145.00
NACIA		40.00
NE COUNCIL OF SCHOOL ADM		2,730.00
OMAHA WORLD-HERALD		1,350.00
ONE SOURCE		207.00
PAPER 101		8,176.36
PITNEY BOWES		96.00
POSTMASTER		114.00
PRAIRIE MECHANICAL CORP		815.00
PUBLICATION PRINTING		354.35
S2 ROLL OFFS, LLC		379.00
SCHOOLS IN, LLC		1,174.90
SCHURMAN, RACHELLE		34.70
STAPLES ADVANTAGE		61.65
SUBURBAN SCHOOLS PROGRAM		2,155.26
TIMECLOCK PLUS, LLC		698.77
VISITING NURSE HEALTH SERVICES		3,858.75
WALMART COMMUNITY		275.40
WASTE CONNECTIONS OF NEBR, INC		924.86
WATER ENGINEERING INC		302.50
WELLS FARGO BANK		12,066.54
WELTON, SHERRY		100.00
Checking Account ID 1		<u>103,562.26</u>
Checking Account ID 2	Fund Number 02 DEPRECIATION	
BSN SPORTS INC		6,946.60
Checking Account ID 2		<u>6,946.60</u>
Checking Account ID 6	Fund Number 06 NUTRITION FUND	
CANTEEN REFRESHMENT SERVICES		209.10
CASH-WA DISTRIBUTING	36	8,389.55
CHESTERMAN CO		379.51

06/07/2023 05:05 PM

JUNE 2023 BOARD BILLS

User ID: CQ

Vendor Name	Vendor Description	Amount
CINTAS CORP		499.80
GOODWIN TUCKER		819.28
HILAND DAIRY		3,800.40
ROTELLA'S ITALIAN BAKERY INC		524.70
SYSCO LINCOLN		4,412.73
US FOOD INC		8,700.26
WELLS FARGO BANK		572.00
Checking Account ID 6		<hr/> 28,307.33

Checking Account ID 8	Fund Number 08	SPECIAL BUILDING FUND	Amount
BERINGER CIACCIO DENNEL MABREY			9,119.75
BOYD JONES CONSTRUCTION CO			423,534.74
RAINWOOD DEVELOPMENT PARTNERS, LLC			13,440.00
THIELE GEOTECH INC			740.00
Checking Account ID 8			<hr/> 446,834.49

06/07/2023 05:34 PM

MID MONTH BILLS - MAY/JUNE 2023

User ID: CQ

Vendor Name	Vendor Description	Amount
Checking Account ID 1	Fund Number 01 GENERAL FUND	
ACH BANK FEE		59.50
COX BUSINESS		553.39
LOVE'S TRAVEL STOPS & COUNTRY STORE		1,311.41
MADISON NATIONAL LIFE INS CO IN		1,899.38
MAGIC WRIGHTER E-SERVICE		209.25
OMAHA PUBLIC POWER DISTRICT		18,080.99
PORKY BUTTS BBQ		2,094.75
SOKOL CAMP ASSOCIATION		75.00
Checking Account ID 1		<hr/> 24,283.67
Checking Account ID 6	Fund Number 06 NUTRITION FUND	
NEBR SCHOOL NUTRITION ASSOC		175.00
Checking Account ID 6		<hr/> 175.00
Checking Account ID 8	Fund Number 08 SPECIAL BUILIDING FUND	
FIRST CITIZENS BANK		234,181.99
Checking Account ID 8		<hr/> 234,181.99

**MINUTES OF THE REGULAR MEETING OF THE BOARD OF
EDUCATION OF DOUGLAS COUNTY SCHOOL DISTRICT 28-0015,
a/k/a, DOUGLAS COUNTY WEST COMMUNITY SCHOOL DISTRICT**

Monday, May 15, 2023

The regular meeting of the Board of Education, District #15, in the County of Douglas, in the State of Nebraska, was convened in open and public session on Monday, May 15, 2023 at the HS/MS Library, 401 S. Pine Street, Valley, Ne 68064-0378

Following public notification procedures approved by the Board of Education, February 14, 2011, in adherence to 84-1411, notice of the meeting was given in advance thereof by posting such Notice on the exterior front door of the high school, elementary school, middle school, Valley City Hall, First Nebraska Bank, and Foundation One Bank. Notice of the meeting was simultaneously given to all members of the Board of Education. Availability of the agenda was communicated in advance notice and in the notice to the Board of Education of the meeting. All proceedings hereafter shown were taken while the convened meeting was open to the attendance of the public.

Attendance Taken at 7:00 PM.

Kelly Hinrichs: Present
Luke Janke: Present
Jamie Jorgensen: Present
Bill Koile: Present
Elizabeth Mayer: Present
Jim Tomanek: Present

Present: 6.

1. Call to Order

The agenda, listing items for consideration by the Board, is on file in the Superintendent's office. Other matters may come before the Board and the Board has the right to modify the agenda before the meeting.

President – “As I call the meeting to order I wish to inform everyone present that a current copy of the Open Meetings Act is posted on the back wall of the Board Room for your review at any time.”

2. Public Communications and Correspondence

Comments from the audience were accepted at this time.

DC West parent Missy Oien addressed the Board regarding the current condition of the elementary playground equipment. She asked that the Board consider a possible update to some of the play equipment as well as making the equipment more adaptive and handicap accessible.

JJ Swirczek addressed the Board on behalf of the DC West Schools Foundation. The Foundation will be starting a fundraising effort to support the purchase of 90 new DC West Band uniforms. The Foundation will be looking for support from the school and local businesses. JJ will return next month to keep the Board updated on their efforts.

The Board also received email communication from Mr. Jim Boucher regarding the Safety Committee security issues & protocols.

3. Approval of Agenda

Motion to approve agenda as presented passed with a motion by Kelly Hinrichs and a second by Luke Janke.

Kelly Hinrichs: Yea, Luke Janke: Yea, Jamie Jorgensen: Yea, Bill Koile: Yea, Elizabeth Mayer: Yea, Jim Tomanek: Yea

Yea: 6, Nay: 0

4. Administrative Reports

4.1. Superintendent's Report

4.2. Financial Report

5. Consent Agenda

Motion to approve Consent Agenda passed with a motion by Kelly Hinrichs and a second by Jamie Jorgensen. Kelly Hinrichs: Yea, Luke Janke: Yea, Jamie Jorgensen: Yea, Bill Koile: Yea, Elizabeth Mayer: Yea, Jim Tomanek: Yea

Yea: 6, Nay: 0

5.1. Approve Minutes

Regular Meeting Date: June 12th, 2023

Special Meeting Date:

5.2. Approve Claims for Payment

5.3. Approve Financial Report

5.4. Approve Classified Staff

Recent Hires:

Kelly Brown (Elementary Sped Para)

Sarah Rochford (Elementary Sped Para)

Vicki Murren (Preschool Para)

Christopher Douglas (Middle School Sped Para)

6. Old Business

6.1. Building and Grounds Update

- Summer Projects Update

The Board was updated on the current gravel parking lot project and discussed which items of the project were considered reconstruction vs. new infrastructure. Dr. Polonic updated the board on the North Gym updates which include: new bleachers in North Gym, resurfacing of the North Gym floor, carpet on the stage and steps leading up to the stage, and locker room renovation.

- Snow Removal, Continuation of Services

Stanzel's Mow and Snow, LLC presented the Board a copy of their continuation of services agreement.

- Replacement of the RTU #7

The roof top unit #7 over the High School commons area is needing a repair or replacement. The Board requested multiple bids for both options of repair or replacement with warranties included.

7. New Business

7.1. Math Curriculum Materials Recommendation and Approval

The Math Curriculum Adoption process has been a year-long effort. Dr. Marten and her committee members presented the process and recommendation to the Board of Education for their approval of new K-12 Math Curriculum Materials and Professional Development to be purchased for the 2023-2024 school year with ESSER Funds. Dr. Marten recommended Envisions Math for the Elementary math curriculum and Reveal Math for Middle School and High School math curriculum.

Motion to approve Math curriculum materials as recommended passed with a motion by Luke Janke and a second by Kelly Hinrichs.

Kelly Hinrichs: Yea, Luke Janke: Yea, Jamie Jorgensen: Yea, Bill Koile: Yea, Elizabeth Mayer: Yea, Jim Tomanek: Yea
Yea: 6, Nay: 0

7.2. Adopt a Resolution to Authorize Joining the Nebraska Educational Building Association

The finance committee met with DA Davidson & representatives from Gilmore & Bell around the concept of joining an interlocal agreement with the Nebraska Educational Building Association. The committee recommended the Board approve the resolution authorizing execution of the agreement providing for the organization and operation of the Nebraska Educational Building Association and appoints members to the board of the Association.

This would allow our District to develop a future opportunity to refinance the lease purchase agreement on DC West Elementary at or near the end of the lease term. The interlocal agreement would provide a more stable mechanism to support the financing for a longer term. The interlocal agreement may also provide future opportunities for other projects.

Board Member Liz Mayer shared personal research and asked that the conversation continue regarding the refinancing methods by considering school bonds. It was also recommended that DA Davidson come and speak to the Finance Committee on the various options of financing.

Motion to Adopt a resolution to authorize joining the Nebraska Educational Building Association. The resolution authorizes execution of the agreement providing for the organization and operation of the Nebraska Educational Building Association and appoints members to the board of this Association. Our current President and Treasurer will serve as representatives. This motion passed with a motion by Bill Koile and a second by Luke Janke.

Kelly Hinrichs: Yea, Luke Janke: Yea, Jamie Jorgensen: Yea, Bill Koile: Yea, Elizabeth Mayer: Yea, Jim Tomanek: Yea
Yea: 6, Nay: 0

7.3. Approve Certificated Staff Resignation

The following certificated staff resignation was received prior to April 28th, the last day to be released from teaching contracts:

- Sara Horstman, 6th Grade Math

Motion to approve the resignation of Sara Horstman, 6th grade math passed with a motion by Luke Janke and a second by Kelly Hinrichs.

Kelly Hinrichs: Yea, Luke Janke: Yea, Jamie Jorgensen: Yea, Bill Koile: Yea, Elizabeth Mayer: Yea, Jim Tomanek: Yea
Yea: 6, Nay: 0

7.4. Approve Certificated Staff Hiring for the 2023-2024 School Year

The administration recommended the following certificated staff for hire beginning the 2023-2024 school year:

- Traci Evans, Middle School Math
- Jesse Hays, 6th Grade Math
- Kim Bottorff, Elementary Special Education
- Pam Dobrolvony, Speech Language Pathologist
- Nancy Johnston, Preschool

Motion to approve; Traci Evans, Middle School Math; Jesse Hays, 6th Grade Math; Kim Bottorff, Elementary Special Education; Pam Dobrolvony, Speech Language Pathologist; Nancy Johnston, Preschool passed with a motion by Jamie Jorgensen and a second by Bill Koile.

Kelly Hinrichs: Yea, Luke Janke: Yea, Jamie Jorgensen: Yea, Bill Koile: Yea, Elizabeth Mayer: Yea, Jim Tomanek: Yea
Yea: 6, Nay: 0

7.5. Approve North Gym Floor Refinishing

Four bids were received for the North Gym Floor Refinishing Project. The floor will be sanded to bare wood, painted and stained, finished and sealed. This project will occur this summer.

- H2I Group \$38,798.00
- Egan Supply \$54,989.00
- Workspace Flooring \$48,680.00
- Stalker Sports Floors \$57,323.00

The administration recommended the bid from H2I Group in the amount of \$35,798.00 be approved.

Motion to approve the gym floor refinishing bid from H2I Group in the amount of \$35,798.00 passed with a motion by Luke Janke and a second by Jamie Jorgensen.

Kelly Hinrichs: Yea, Luke Janke: Yea, Jamie Jorgensen: Yea, Bill Koile: Yea, Elizabeth Mayer: Yea, Jim Tomanek: Yea
Yea: 6, Nay: 0

7.6. Approve Recommended Classified and Administrative Salaries for the 2023-2024 School Year

The Negotiations Committee of the Board met on April 25, 2023 to review salary arrays and determine recommended pay increases for classified and administrative staff. The total compensation increase for classified staff is an average of 3.8%. The total compensation increase for administrative staff is an average of 3.8%.

Motion to approve the recommended salaries for the classified and administrative staff for the 2023-2024 school year as recommended passed with a motion by Jamie Jorgensen and a second by Jim Tomanek.

Kelly Hinrichs: Yea, Luke Janke: Yea, Jamie Jorgensen: Yea, Bill Koile: Yea, Elizabeth Mayer: Yea, Jim Tomanek: Yea
Yea: 6, Nay: 0

7.7. Approve the Addition of Classified Staff for the 2023-2024 School Year

Nicki Pechous, Director of Special Education, has been reviewing projected special education student need calculations for the 2023-2024 school year. She recommended the addition of:

- 3 New Elementary Special Education Paras
- 1 New Middle School Special Education Para

Scott Perrigo, Director of Buildings and Grounds, has been reviewing the projected square footage addition of 80,000 square feet for cleaning upon opening the new Middle School/ Fine Arts Wing in the 2023-2024 school year and we are recommending the addition of:

- 2 Full-Time Custodians

Motion to approve four special education paraprofessionals and two custodians for the 2023-2024 school year passed with a motion by Luke Janke and a second by Kelly Hinrichs.

Kelly Hinrichs: Yea, Luke Janke: Yea, Jamie Jorgensen: Yea, Bill Koile: Yea, Elizabeth Mayer: Yea, Jim Tomanek: Yea
Yea: 6, Nay: 0

8. Adjournment

Motion to adjourn meeting at 7:54pm passed with a motion by Kelly Hinrichs and a second by Jamie Jorgensen.

Kelly Hinrichs: Yea, Luke Janke: Yea, Jamie Jorgensen: Yea, Bill Koile: Yea, Elizabeth Mayer: Yea, Jim

Tomanek: Yea

Yea: 6, Nay: 0



Kristi Trost, Board Secretary

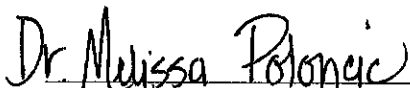

Dr. Melissa Polonic, Superintendent

**MINUTES OF THE REGULAR MEETING OF THE BOARD OF
EDUCATION OF DOUGLAS COUNTY SCHOOL DISTRICT 28-0015,
a/k/a, DOUGLAS COUNTY WEST COMMUNITY SCHOOL DISTRICT
Wednesday, May 24, 2023**

The regular meeting of the Board of Education, District #15, in the County of Douglas, in the State of Nebraska, was convened in open and public session on Wednesday, May 24, 2023 in the High School commons area, 401 South Pine Street, Valley, NE 68064-0378.

Following public notification procedures approved by the Board of Education, February 14, 2011, in adherence to 84-1411, notice of the meeting was given in advance thereof by posting such Notice on the exterior front door of the high school, elementary school, middle school, Valley City Hall, First Nebraska Bank, and Foundation One Bank. Notice of the meeting was simultaneously given to all members of the Board of Education. Availability of the agenda was communicated in advance notice and in the notice to the Board of Education of the meeting. All proceedings hereafter shown were taken while the convened meeting was open to the attendance of the public.

Attendance Taken at 6:30 PM.

Kelly Hinrichs: Present
Luke Janke: Present
Jamie Jorgensen: Present
Bill Koile: Absent
Elizabeth Mayer: Absent
Jim Tomanek: Present

Present: 4, Absent: 2.

1. Call to Order

The agenda, listing items for consideration by the Board, is on file in the Superintendent's office. Other matters may come before the Board and the Board has the right to modify the agenda before the meeting.

President -- "As I call the meeting to order I wish to inform everyone present that a current copy of the Open Meetings Act is posted on the back wall of the Board Room for your review at any time."

2. Approval of Agenda

Motion to approve agenda as presented passed with a motion by Luke Janke and a second by Jamie Jorgensen.

Kelly Hinrichs: Yea, Luke Janke: Yea, Jamie Jorgensen: Yea, Jim Tomanek: Yea
Yea: 4, Nay: 0

3. New Business

3.1. Approve Southwest Parking Lot Project Bid

A bid response package was collected on our behalf by Lamp Rynearson. Mackie Construction, LLC, submitted the low bid of \$702,297.96. The estimated budget for the project was \$877,331. The following bids were received:

Mackie Construction, \$702,297.96

TR Construction, \$824,897.35

DPS LLC, \$831,041.45

The administration supports Lamp Rynearson's recommendation to award the work to Mackie Construction, LLC.

Motion to approve the bid for the southwest parking lot project from Mackie Construction in the amount of \$702,297.96 to be completed this summer passed with a motion by Luke Janke and a second by Jim Tomanek.

Kelly Hinrichs: Yea, Luke Janke: Yea, Jamie Jorgensen: Yea, Jim Tomanek: Yea
Yea: 4, Nay: 0

3.2. Approve the Purchase of K-12 Math Curriculum Materials

As presented at the May 15, 2023 meeting, the math curriculum pilot committee along with administration recommended the following purchases be made with ESSER II Funds:

K-5th grade SAVVAS Math Curriculum in the amount of \$144,754.88

6-12th grade McGraw Hill Math Curriculum in the amount of \$53,367.79

Motion to approve K-5th grade SAVVAS Math Curriculum in the amount of \$144,754.88; 6-12th grade McGraw Hill Math Curriculum in the amount of \$53,367.79 passed with a motion by Jamie Jorgensen and a second by Kelly Hinrichs.

Kelly Hinrichs: Yea, Luke Janke: Yea, Jamie Jorgensen: Yea, Jim Tomanek: Yea

Yea: 4, Nay: 0

3.3. Consider, Discuss, and Take Action to Select District Newspaper of Record

Due to inconsistencies with our current newspaper of record, the administration recommended a new selection for our district newspaper of record. The recommendation is The Daily Record in Omaha, Nebraska.

Move to select The Daily Record as the newspaper of record passed with a motion by Kelly Hinrichs and a second by Jamie Jorgensen.

Kelly Hinrichs: Yea, Luke Janke: Yea, Jamie Jorgensen: Yea, Jim Tomanek: Yea

Yea: 4, Nay: 0

4. Adjournment

Motion to adjourn meeting at 6:35 pm passed with a motion by Luke Janke and a second by Kelly Hinrichs.

Kelly Hinrichs: Yea, Luke Janke: Yea, Jamie Jorgensen: Yea, Jim Tomanek: Yea

Yea: 4, Nay: 0

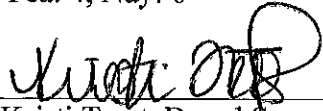

Kristi Trost, Board Secretary

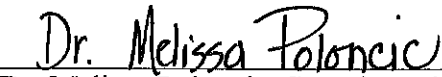

Dr. Melissa Poloncic, Superintendent

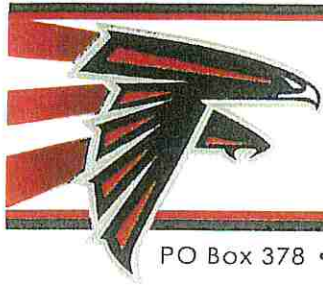

DC WEST
COMMUNITY SCHOOLS

CREATING PASSIONATE LEARNERS

PO Box 378 • Valley, NE 68064 • www.dcwest.org • Ph: 402.359.2583 Fax: 402.359.4371

**DC West Board of Education Policy Committee
Policy 5204 Grading Recommendation of Change**

DC West Grading Committee:

- 1. Committee Members: Administrators, Teachers and Parents**
- 2. Meeting Dates: April 20 and 27, 2023**
- 3. Purpose of Grading Committee:**
 - **District Strategic Plan Strategy 1.3:** Research, study, and consider the current grading system(s) used in DC West Community Schools.
 - **Strategy 1.3(c) Performance Indicator:** Evaluate the current grading system(s) to ensure successful student learning needs of DC West.
- 4. Committee Agenda Items:**
 - Reviewed DCW Board Policy 5204: Grading System
 - Compared MOEC and conference school district grading scales
 - Reasons for Grading Scale review in alignment to District Strategic Plan:
 1. Grading scale may not benefit students with college admission and scholarships
 2. Negative impact on graduation rate
 3. College scholarships - ACT no longer being used as much
 4. Consistency with peers - Our students are competing against their students for scholarships
 - Discussion on recommending a change to the Grade 3-12 Grading Scale: 7-point, 10-point, or remain the same
 - Pros to moving to a 10-point Grading Scale:
 1. Matching area schools, creating more level playing field compared to other districts
 2. Matches college scale, seamless transition to college
 3. Scholarship opportunities
 4. Adding the "+" to Board Policy
 - Cons to Moving to a 10-point Grading Scale:
 1. Perception of lowering the bar or standard
 2. Traditional mindset
 3. Time to educate community members and teachers

The DCW Grading Committee makes the following recommendation of change to Board Policy 5204.



DC WEST

COMMUNITY SCHOOLS

CREATING PASSIONATE LEARNERS

PO Box 378 • Valley, NE 68064 • www.dcwest.org • Ph: 402.359.2583 Fax: 402.359.4371

Ashland-Greenwood, Springfield Platteview, Papillion, Bellevue A: 90-100 (10) B: 80-89 (9) C: 70-79 (9) D: 60-69 (9) F: 0-59	Elkhorn, Syracuse A: 93-100 (7) B: 85-92 (7) C: 78-84 (6) D: 70-77 (7) F: 0-69 *Syracuse: grades 4-6 have a 10-point scale	Millard A: 93-100 (7) B: 85-92 (7) C: 77-84 (7) D: 69-76 (7) F: 0-68	Wahoo A: 93-100 (7) B: 85-92 (7) C: 77-84 (7) D: 70-76 (6) F: 0-69	Gretna, Yutan, Fort Calhoun, Logan View, Louisville, Raymond Central A: 94-100 (6) B: 86-93 (7) C: 78-85 (7) D: 70-77 (7) F: 0-69
Conestoga A: 94-100 (6) B: 86-93 (7) C: 77-85 (8) D: 70-76 (6) F: 0-69	Arlington A: 93-100 (7) B: 85-92 (7) C: 76-84 (8) D: 70-75 (5) F: 0-69	Bennington A: 93-100 (7) B: 86-92 (6) C: 77-85 (8) D: 70-76 (6) F: 0-69	Ralston A: 92-100 (8) B: 84-91 (7) C: 76-83 (7) D: 67-75 (8) F: 0-66	DC West A: 94-100 (6) B: 87-93 (6) C: 77-86 (9) D: 70-76 (6) F: 0-69

Districts part of the 10-point scale conversation:

Seward	Elkhorn	Ralston	Gering	Beatrice	Millard
Bennington	Wahoo	Norfolk	DC West	Gretna	Beatrice
Tri-County	Schuyler	South Platte	Waverly	North Platte	

Students

Grading System

The grading system of Douglas County West Community Schools shall be as follows:

- a. Achievement marks shall be given on a numerical basis for all grades 3-12 with the mark of 59 or lower considered a failure.
- b. The grading scale is as follows:

A	=	90-100
B+	=	87-89
B	=	80-86
C+	=	77-79
C	=	70-76
D+	=	67-69
D	=	60-66
F	=	0-59
I	=	Incomplete may be given to students that have not completed work by the end of the semester. Students have one week to complete course work in those subject areas. Course work not made up will result in a failing grade.
P or NP	=	Pass or No Pass grades will be issued under special circumstances as approved by the administration.

- c. For all other grading reports received for transfer students, the principal or designee shall convert the grades to an approximately equal grade on our system.
- d. All grade reports will contain the numerical grade for each subject, as well as the following: absences, tardiness, comments (if teacher desires).

Date of Adoption:

Students

Grading System

The grading system of Douglas County West Community Schools shall be as follows:

- a. ~~Grading periods of approximately nine (9) weeks shall be used four (4) times per year.~~
- b. Achievement marks shall be given on a numerical basis for all grades ~~4-12~~ 3-12; with the marks of ~~69~~ 59 or lower considered a failure. ~~Grades K-2 will shall receive performance marks based on the identified scale listed below. scale special grading report for the K-3 K-2, on a different basis, shall be used.~~
- c. The grading ~~and conversion~~ scale ~~are~~ is as follows:

A	=	94-100 90-100	Excellent
B+	=	87-89	Good
B	=	87-93 80-86	Average
C+	=	77-79	Below Average
C	=	77-86 70-76	Failing
D+	=	67-69	
D	=	70-76 60-66	
F	=	Below 70 0-59	
NC	=	No Credit (used for withdrawal after the first week of first semester and after the first two days of second semester).	
NG I	=	No Grade and is Incomplete may be given to students that have not completed work by the end of the semester. Students have one week to complete course work in those subject areas. Course work not made up will result in a failing grade.	
NM	=	No Mark may be given for any class that a student wishes to retake. The NM will be given at the time the student designates which grade they wish to have listed on their permanent record. The NM is not a credit and if the course is a requirement for graduation, students will need to successfully pass the class before credit is given for completed work.	
P or NP	=	Pass or No Pass grades will be issued under special circumstances as approved by the administration.	

- d. For all other grading reports received ~~on~~ for transfer students, the ~~Superintendent and/or~~ principal ~~or designee~~ shall convert ~~these~~ the grades to an approximately equal grade on our system.
- e. ~~Staff members may use whatever method they determine professionally appropriate in the day to day grading, but shall prepare grade reports based on numerical values. Each staff~~

~~member, however, must be able to defend whatever method chosen. The following criteria should be used in determining the numerical value of the grade.~~

- ~~1. Achievement in relation to class objectives.~~
 - ~~2. Class participation.~~
 - ~~3. Mental ability of student in relation to the total class and required work.~~
 - ~~4. Evidence the student is exceeding the class requirements and delving further.~~
- ~~f. On excused absences of secondary students, they shall be allowed two (2) days for each day missed to complete work assigned. After this period elapses, all work not handed in or completed shall receive a zero.~~
- ~~g. On unexcused absences, all work assigned shall receive a zero, or a grade assigned for class participation shall also receive a zero, and also possibility of a disciplinary action.~~
- h. All grade reports will contain the numerical grade for each subject, as well as the following: absences, tardiness, ~~department~~, comments (if ~~instructor teacher~~ desires).

Date of Adoption: August 15, 2022

**Phone System Briefing to the BOE
From Sandi Kerkhoff, Director of Technology
June 12, 2023**

The rationale behind upgrading to a new phone system.

After doing some research it was discovered we are paying a lot of money to keep up our current, but outdated phone system up and running.

Our original reason to research was needing more phones to open the new Middle School and Arts addition. It is not as simple as just ordering new phones, with our system being pretty dated, new phones would not work on it. It would be almost \$10,000 to upgrade our current on-premise phone system controller to get it to work with the current phones and any new phones. If we were to upgrade the current system, we could piece together and keep the old phones running and get new ones to run on that system, it just doesn't make sense to sink more money into an already outdated and expensive-to-service phone system.

As we grow as a district and update our facilities, our phones have been left behind. Typically the hardware on a phone system will last several years (7-10 years), but eventually, just like any technology, it becomes obsolete. The current phone technology is limiting the flexibility of our administration team as well as lacking some features that could help our efficiency as a whole. From what Cindy and I could find going back and looking at invoices, the current phone system was most likely installed in 2009.

Features to consider in a new phone system we cannot get in our current phone system:

Voicemails to Email. (for ALL).

Direct Numbers (DIDs) for Administration, Directors, SRO (with Zoom all teachers would have)

The flexibility of most all staff to answer calls to their Direct DID DCWest number on their personal device. (Phone, iPad, Computer).

Recommendation for New Phone System - Zoom Phones.

I recommend going forward with replacing our current phone system with a hosted phone system - Zoom Phones. I have attached 3 quotes with a similar option, also hosted phones. We currently have an on-premise system that has to be serviced and maintained by a communication company. The hosted phone system takes the system to the cloud and is maintained by the service provider with the monthly service cost.

The reasons I want to recommend the Zoom Phone system over the other 2 quotes:

#1. The Zoom Phone system is intuitive enough that I will be able to handle the installation and setup in-house. So, as you notice on the Zoom Phone quote, there is no installation included.

#2. The Zoom Phone system is just an additional piece to Zoom Meetings, which all of our staff was familiarized with during the pandemic. This will be the smoothest transition for all.

#3. The Zoom Phone system has so many features that our staff currently does not have that will provide for more efficient Admin & Secretaries and more flexibility for Teachers.

#4. Emergency Response. ALL staff (including paras) will be able to call 911 from an iPad, Cellphone, or Laptop using the Zoom App on WiFi. (small resolution for no cell service).

When looking at the quotes, something to consider is the ongoing expenses with the current on-premise phone system with Cox and Dice Communications.

We purchase a 'SIP Trunk' from Cox for ~\$320/month.

*This is a digital group of telephone numbers. We do still have 3 analog lines connected to our Fire/Security Panels that will remain with Cox. So our entire Cox Bill will not go away, but a good chunk of it will go away with a hosted phone system, such as Zoom.

We currently pay Dice Communications annually to maintain the on-premise phone system. With the Zoom Phone system, the updates and maintenance will be taken care of by Zoom. We will no longer need to pay a 3rd party ~\$6400/year.

As far as the timeline. If we can place the order as soon as it is approved I should have the phones in hand in June. Currently, the hardware with CDW is shipping the same day or within 2-3 days, putting them in our hands by June 20 at the latest if we order on June 13. This will give me plenty of time to get them all set up and ready to go by the end of July for heavy users and the rest of the staff when they return in August.

I have attached the following:

Quote from Zoom for Monthly with CDW. (compare apples to apples w/ other quotes)

Quote from Zoom for Annual with CDW. (option for an annual payment to Zoom for service)

Quote from Infinite Solutions - 3CX Phone System.

Quote from Voice and Data - Wildix Phone System.



Thank you for choosing CDW. We have received your quote.

Review and Complete Purchase

SANDI KERKHOFF,

Thank you for considering CDW•G for your technology needs. The details of your quote are below. **If you are an eProcurement or single sign on customer, please log into your system to access the CDW site.** You can search for your quote to retrieve and transfer back into your system for processing.

For all other customers, click below to convert your quote to an order.

Convert Quote to Order

QUOTE #	QUOTE DATE	QUOTE REFERENCE	CUSTOMER #	GRAND TOTAL
NKMN654	6/2/2023	POLY UPDTED	8446860	\$33,333.45

QUOTE DETAILS				
ITEM	QTY	CDW#	UNIT PRICE	EXT. PRICE
Poly Edge E450 - VoIP phone with caller ID call waiting - 3-way call capabi Mfg. Part#: 2200-87030-025 Contract: Nebraska ESU Cooperative Purchasing (022-G)	5	7143298	\$196.24	\$981.20
Poly Savi 8220 UC - Standard - wireless headset system Mfg. Part#: 209215-01 Contract: Nebraska ESU Cooperative Purchasing (022-G)	3	5906209	\$232.00	\$696.00
Poly CS540 - Wireless Headset Mfg. Part#: 84693-01 UNSPSC: 52161514 Contract: Nebraska ESU Cooperative Purchasing (022-G)	3	2468326	\$232.00	\$696.00
Poly Studio X70 - video conferencing kit - with Poly TC8 Mfg. Part#: 7200-87300-001 Contract: Nebraska ESU Cooperative Purchasing (022-G)	1	6690401	\$4,521.76	\$4,521.76
Poly Studio X50 - Video Conferencing Kit - with Poly TC8 Mfg. Part#: 2200-86270-001 Contract: Nebraska ESU Cooperative Purchasing (022-G)	2	5825403	\$2,456.57	\$4,913.14
Poly - expansion module Mfg. Part#: 2200-87020-025 Contract: Nebraska ESU Cooperative Purchasing (022-G)	5	7143297	\$148.19	\$740.95
Poly CCX 600 OpenSIP - VoIP phone Mfg. Part#: 2200-49780-025 Contract: Nebraska ESU Cooperative Purchasing (022-G)	25	6198791	\$400.00	\$10,000.00

QUOTE DETAILS (CONT.)

[Poly Edge E220 - VoIP phone with caller ID call waiting - 3-way call capabi](#) 110 7143294 \$98.04 \$10,784.40

Mfg. Part#: 2200-86990-025

Contract: Nebraska ESU Cooperative Purchasing (022-G)

SUBTOTAL	\$33,333.45
SHIPPING	\$0.00
SALES TAX	\$0.00
GRAND TOTAL	\$33,333.45

PURCHASER BILLING INFO	DELIVER TO
Billing Address: DOUGLAS COUNTY WEST COMMUNITY SCHOO ACCOUNTS PAYABLE PO BOX 378 BOARD OF EDUCATION VALLEY, NE 68064-0378 Phone: (402) 359-2583 Payment Terms: NET 30 Days-Govt/Ed	Shipping Address: DOUGLAS COUNTY WEST COMMUNITY SCHOO SANDI KERKHOFF PO BOX 378 BOARD OF EDUCATION VALLEY, NE 68064-0378 Phone: (402) 359-2583 Shipping Method:
Please remit payments to:	
CDW Government 75 Remittance Drive Suite 1515 Chicago, IL 60675-1515	



Sales Contact Info

Nick Schultz (K-12) | (312) 547-5027 | nischul@cdwg.com

LEASE OPTIONS			
FMV TOTAL	FMV LEASE OPTION	BO TOTAL	BO LEASE OPTION
\$33,333.45	\$901.67/Month	\$33,333.45	\$1,039.00/Month

Monthly payment based on 36 month lease. Other terms and options are available. Contact your Account Manager for details. Payment quoted is subject to change.

Why finance?

- Lower Upfront Costs. Get the products you need without impacting cash flow. Preserve your working capital and existing credit line.
- Flexible Payment Terms. 100% financing with no money down, payment deferrals and payment schedules that match your company's business cycles.
- Predictable, Low Monthly Payments. Pay over time. Lease payments are fixed and can be tailored to your budget levels or revenue streams.
- Technology Refresh. Keep current technology with minimal financial impact or risk. Add-on or upgrade during the lease term and choose to return or purchase the equipment at end of lease.
- Bundle Costs. You can combine hardware, software, and services into a single transaction and pay for your software licenses over time! We know your challenges and understand the need for flexibility.

General Terms and Conditions:

This quote is not legally binding and is for discussion purposes only. The rates are estimate only and are based on a collection of industry data from numerous sources. All rates and financial quotes are subject to final review, approval, and documentation by our leasing partners. Payments above exclude all applicable taxes. Financing is subject to credit approval and review of final equipment and services configuration. Fair Market Value leases are structured with the assumption that the equipment has a residual value at the end of the lease term.



Order Form Number: Q2119844
Valid Until: 06/21/2023

Zoom Video Communications Inc. ('Zoom')
 55 Almaden Blvd, 6th Floor
 San Jose, CA

<p>Billed To</p> <p>Customer: DC West Community Schools Account Legal Name: DC West Community Schools Contact Name: Zoom Admin 401 S Pine St, PO Box 378 Valley, Nebraska 68064, United States Email Address: zoom@dcwest.org Phone: 4023592583</p>	<p>Sold To</p> <p>Customer: DC West Community Schools Account Legal Name: DC West Community Schools Contact Name: Zoom Admin 401 S Pine St, PO Box 378 Valley, Nebraska 68064, United States Email Address: zoom@dcwest.org Phone: 4023592583</p>
<p>Auto Renew: Yes Initial Paid Subscription Term: 12 Month Renewal Subscription Term: 12 Month Paid Period Start Date: 05/22/2023</p>	<p>Billing Method: Email Currency: USD Payment Term: Net 30</p>

This Zoom Order Form and any other Order Forms that reference this Order Form are governed by the Zoom Terms of Service found at <http://www.zoom.us/terms> (unless Customer and Zoom have entered a written governing Master Subscription Agreement, in which case such written agreement will govern).

SERVICE	BILLING PERIOD	QUANTITY	PRICE	TOTAL
Education Annual	Annual	20	USD 6.00	USD 120.00
Zoom Phone Common Area Annual	Annual	6	USD 48.00	USD 288.00
Zoom Phone US/Canada Phone Numbers Annual	Annual	3	USD 60.00	USD 180.00
Zoom Phone US/Canada Unlimited Calling Named User Annual	Annual	130	USD 96.00	USD 12,480.00
Zoom Phone Monthly Usage - overage fee	Month	NA	NA	NA
Zoom Phone Pay As You Go	Month	1	USD 0.00	USD 0.00
Zoom Rooms Annual	Annual	1	USD 499.00	USD 499.00

(Before Taxes)	
Annual Payment:	USD 13,567.00

Payment Schedule Summary (Before Taxes)
First Payment: USD 13,567.00
Annual Recurring Payment: USD 13,567.00 (At the beginning of the Second Year)

Named Host - means any subscribed host who may host an unlimited number of meetings during the Term using the Service. Any meeting will have at least one Named Host. Unless Customer has purchased an extended capacity, the number of participants (participants do not require a subscription) will not exceed 300 per meeting. Named Host subscription may not be shared or used by anyone other than the individual to whom the Named Host subscription is assigned.

Zoom EDU subscriptions are intended for student and faculty and pedagogical interaction within a classroom environment, or the administration thereof and may not be used for any commercial purpose. Zoom EDU subscriptions may not be purchased by hospitals, medical centers, clinics, or other affiliated organizations not specifically involving student and faculty and pedagogical interactions within a classroom environment or the administration thereof. Country or region availability for Zoom Phone is listed on Zoom's website and is subject to change (see <https://explore.zoom.us/docs/en-us/zoomphone/global-coverage.html>).

Fees - The fees for the Services, if any, are described in the Order Form. The actual fees may also include overage amounts or per use charges for audio and/or cloud recording in addition to the fees in the Order, if such use is higher than the amounts described in the Order, and you agree to pay these amounts or charges if you incur them. Invoicing for Services begins on the first day that the service is available for use by the Customer and monthly thereafter for the duration Term, except for annual pre-pay option which is invoiced once in the first month of the annual term. Amendment orders will co-term with the existing subscription term end date. Invoices are pro-rated from paid period start date to base subscription end date. Purchase order, if any, issued in connection with this order should reference the above order form number. Commitments not utilized by the Customer during the month for which they are committed may not be carried forward into any subsequent month or term.

All prices shown for Zoom and Zoom Phone services are exclusive of taxes. The term 'taxes' referred herein should encompass: US state and local taxes, VAT, GST, HST (or any other consumption taxes), Digital Service Taxes and Withholding Taxes that may apply upon making payments to Zoom. Regulatory telecommunications fees, such as USF or any similar foreign fee, will apply to Zoom Phone services and details of taxes and fees will be included in issued invoices.

Professional Services, if purchased, will be presented in a separate Order Form.

Zoom Phone Rates

Zoom Phone Table Format: Country | Landline Rate | Mobile Rate | Enabled Status

Y means Zoom Phone for country is Enabled upon provisioning

N means Zoom Phone for country is Not Enabled upon provisioning

Toll-Free				Callout			
Country	Landline Rate	Mobile Rate	Enabled Status	Country	Landline Rate	Mobile Rate	Enabled Status
Not Applicable				ANTIGUA AND BARBUDA	1.0218 \$	1.0486 \$	Y
				ARGENTINA	0.1156 \$	0.5623 \$	Y
				AUSTRIA	0.0501 \$	0.23 \$	Y
				BULGARIA	0.1186 \$	0.8406 \$	Y
				BOLIVIA (PLURINATIONAL STATE OF)	0.5155 \$	0.8003 \$	Y
				BONAIRE, SINT EUSTATIUS AND SABA	0.7028 \$	0.7028 \$	Y
				BOTSWANA	0.436 \$	0.9398 \$	Y
				COCOS (KEELING) ISLANDS	0.4552 \$	0 \$	Y
				SWITZERLAND	0.3694 \$	0.7011 \$	Y
				CURAÇAO	0.2813 \$	0.7028 \$	Y
				CHRISTMAS ISLAND	0.4552 \$	0 \$	Y
				CYPRUS	0.0953 \$	0.2861 \$	Y
				GERMANY	0.0353 \$	0.1434 \$	Y
				DOMINICAN REPUBLIC	0.1716 \$	0.3824 \$	Y
				ALGERIA	0.3773 \$	2.1167 \$	Y
				ECUADOR	0.5392 \$	0.7572 \$	Y
				WESTERN SAHARA	0.5182 \$	0 \$	Y
				SPAIN	0.0381 \$	0.1832 \$	Y
				FINLAND	0.8584 \$	0.864 \$	Y
				GRENADA	1.0196 \$	1.2758 \$	Y
				GREECE	0.0911 \$	0.3357 \$	Y
				HONG KONG SAR	0.0863 \$	0.1333 \$	Y
				INDONESIA	0.1486 \$	0.2407 \$	Y
				ISRAEL	0.0639 \$	0.1161 \$	Y
				INDIA	0.0915 \$	0.0837 \$	Y
				JORDAN	0.6552 \$	0.8567 \$	Y

KENYA | 0.9342 \$ | 0.7235 \$ | Y
 CAYMAN ISLANDS | 0.7259 \$ | 0.4934 \$ | Y
 KAZAKHSTAN | 0.3587 \$ | 0.6853 \$ | Y
 SAINT LUCIA | 0.9581 \$ | 0.5276 \$ | Y
 MALAYSIA | 0.1001 \$ | 0.0918 \$ | Y
 NETHERLANDS | 0.0913 \$ | 0.4453 \$ | Y
 NEW ZEALAND | 0.0567 \$ | 0.2556 \$ | Y
 OMAN | 0.5335 \$ | 1.1352 \$ | Y
 PANAMA | 0.0485 \$ | 0.994 \$ | Y
 PHILIPPINES | 0.5808 \$ | 0.7074 \$ | Y
 POLAND | 0.137 \$ | 0.3728 \$ | Y
 PORTUGAL | 0.026 \$ | 0.1545 \$ | Y
 RÉUNION | 0.3569 \$ | 0.6072 \$ | Y
 ROMANIA | 0.0812 \$ | 0.2815 \$ | Y
 RUSSIAN FEDERATION | 0.1054 \$ | 0.8892 \$ | Y
 SINGAPORE | 0.0329 \$ | 0.0335 \$ | Y
 SLOVENIA | 0.1855 \$ | 1.1228 \$ | Y
 UKRAINE | 0.5868 \$ | 1.0755 \$ | Y
 URUGUAY | 0.2285 \$ | 0.8432 \$ | Y
 HOLY SEE (VATICAN CITY) | 0.0082 \$ | 0 \$ | Y
 VENEZUELA (BOLIVARIAN REPUBLIC OF) | 0.0518 \$ | 0.2809 \$ | Y
 VIRGIN ISLANDS (U.S.) | 0.9646 \$ | 1.5308 \$ | Y
 ASCENSION ISLAND | 1.8943 \$ | 1.065 \$ | Y
 ANDORRA | 0.1589 \$ | 0.348 \$ | Y
 UNITED ARAB EMIRATES | 0.6535 \$ | 0.6535 \$ | Y
 AFGHANISTAN | 0.3124 \$ | 0.3766 \$ | Y
 ANGUILLA | 1.0442 \$ | 1.0442 \$ | Y
 ALBANIA | 0.2534 \$ | 0.7026 \$ | Y
 ARMENIA | 0.3098 \$ | 0.3455 \$ | Y
 NETHERLANDS ANTILLES | 0.1956 \$ | 0.15 \$ | Y
 ANGOLA | 0.6882 \$ | 0.5871 \$ | Y
 AMERICAN SAMOA | 0.3267 \$ | 0.3267 \$ | Y
 AUSTRALIA | 0.0443 \$ | 0.182 \$ | Y
 ARUBA | 0.1557 \$ | 0.3294 \$ | Y
 AZERBAIJAN | 0.434 \$ | 0.5256 \$ | Y
 BOSNIA AND HERZEGOVINA | 0.6177 \$ | 1.313 \$ | Y
 BARBADOS | 0.972 \$ | 1.0238 \$ | Y
 BANGLADESH | 0.1703 \$ | 0.1697 \$ | Y
 BELGIUM | 0.308 \$ | 0.5272 \$ | Y
 BURKINA FASO | 0.5944 \$ | 0.6532 \$ | Y
 BAHRAIN | 0.4356 \$ | 0.5154 \$ | Y
 BURUNDI | 0.788 \$ | 0.8907 \$ | Y
 BENIN | 0.602 \$ | 0.5223 \$ | Y
 BERMUDA | 0.3216 \$ | 0.3216 \$ | Y
 BRUNEI DARUSSALAM | 0.1424 \$ | 0.0558 \$ | Y
 BRAZIL | 0.0524 \$ | 0.2582 \$ | Y
 BAHAMAS | 0.6278 \$ | 0.6278 \$ | Y
 BHUTAN | 0.1257 \$ | 0.1025 \$ | Y
 BELARUS | 0.6629 \$ | 0.6641 \$ | Y
 BELIZE | 1.533 \$ | 1.533 \$ | Y
 CANADA | 0.0355 \$ | 0.0355 \$ | Y
 CONGO, DEMOCRATIC REPUBLIC OF THE | 0.867 \$ | 0.7109 \$ | Y
 CENTRAL AFRICAN REPUBLIC | 1.0972 \$ | 0.8121 \$ | Y
 COTE D'IVOIRE | 0.67 \$ | 0.7129 \$ | Y
 COOK ISLANDS | 1.5994 \$ | 1.3205 \$ | Y
 CHILE | 0.1132 \$ | 0.5309 \$ | Y
 CAMEROON | 0.4107 \$ | 0.5179 \$ | Y
 CHINA | 0.0395 \$ | 0.0395 \$ | Y
 COLOMBIA | 0.117 \$ | 0.1003 \$ | Y
 COSTA RICA | 0.1231 \$ | 0.3139 \$ | Y
 CABO VERDE | 0.5317 \$ | 0.3612 \$ | Y
 CZECHIA | 0.113 \$ | 0.2348 \$ | Y
 DIEGO GARCIA | 0.435 \$ | 0.435 \$ | Y
 DJIBOUTI | 0.7215 \$ | 0.5718 \$ | Y
 DENMARK | 0.0327 \$ | 0.1404 \$ | Y
 DOMINICA | 1.0227 \$ | 0.7727 \$ | Y
 ESTONIA | 2.1381 \$ | 2.0891 \$ | Y
 EGYPT | 0.4326 \$ | 0.6226 \$ | Y
 ERITREA | 0.7029 \$ | 0.4078 \$ | Y
 ETHIOPIA | 0.4027 \$ | 0.3803 \$ | Y
 FIJI | 1.5038 \$ | 0.7631 \$ | Y
 FALKLAND ISLANDS (MALVINAS) | 1.9702 \$ | 1.9702 \$ | Y
 MICRONESIA (FEDERATED STATES OF) | 0.8686 \$ | 0.8308 \$ | Y
 FAROE ISLANDS | 0.1524 \$ | 0.0288 \$ | Y
 FRANCE | 0.0329 \$ | 0.126 \$ | Y
 GABON | 0.6246 \$ | 0.6921 \$ | Y
 UNITED KINGDOM | 0.0233 \$ | 0.0682 \$ | Y
 GEORGIA | 0.8426 \$ | 1.1833 \$ | Y
 FRENCH GUIANA | 0.2043 \$ | 0.1204 \$ | Y

GUERNSEY | 0.0233 \$ | 0.0682 \$ | Y
 GHANA | 1.1366 \$ | 1.1366 \$ | Y
 GIBRALTAR | 0.2334 \$ | 0.9396 \$ | Y
 GREENLAND | 1.125 \$ | 0.3228 \$ | Y
 GAMBIA | 0.6642 \$ | 0.801 \$ | Y
 GUINEA | 1.1618 \$ | 0.9137 \$ | Y
 GUADELOUPE | 0.0265 \$ | 0.1017 \$ | Y
 EQUATORIAL GUINEA | 2.7398 \$ | 2.7398 \$ | Y
 GUATEMALA | 0.625 \$ | 0.7812 \$ | Y
 GUAM | 0.0409 \$ | 0.0409 \$ | Y
 GUINEA-BISSAU | 0.8951 \$ | 0.9941 \$ | Y
 GUYANA | 0.333 \$ | 0.3282 \$ | Y
 HONDURAS | 0.1846 \$ | 0.2305 \$ | Y
 CROATIA | 0.458 \$ | 1.251 \$ | Y
 HAITI | 0.3532 \$ | 0.4437 \$ | Y
 HUNGARY | 0.1209 \$ | 0.2156 \$ | Y
 IRELAND | 0.0256 \$ | 0.1784 \$ | Y
 ISLE OF MAN | 0.0233 \$ | 0.0682 \$ | Y
 IRAQ | 0.2409 \$ | 0.2955 \$ | Y
 ICELAND | 0.2305 \$ | 0.1054 \$ | Y
 ITALY | 0.0338 \$ | 0.2172 \$ | Y
 JERSEY | 0.0233 \$ | 0.0682 \$ | Y
 JAMAICA | 1.0442 \$ | 1.0442 \$ | Y
 JAPAN | 0.0601 \$ | 0.137 \$ | Y
 KYRGYZSTAN | 0.2141 \$ | 0.3367 \$ | Y
 CAMBODIA | 0.3497 \$ | 0.3497 \$ | Y
 KIRIBATI | 1.9284 \$ | 2.1749 \$ | Y
 COMOROS | 0.6617 \$ | 0.7148 \$ | Y
 SAINT KITTS AND NEVIS | 0.9292 \$ | 0.9292 \$ | Y
 KOREA, REPUBLIC OF | 0.1029 \$ | 0.1029 \$ | Y
 KUWAIT | 0.3625 \$ | 0.3625 \$ | Y
 LAO PEOPLE'S DEMOCRATIC REPUBLIC | 0.2884 \$ | 0.1503 \$ | Y
 Y
 LEBANON | 0.1964 \$ | 0.2401 \$ | Y
 LIECHTENSTEIN | 0.4236 \$ | 0.213 \$ | Y
 SRI LANKA | 0.6953 \$ | 0.6953 \$ | Y
 LIBERIA | 0.7744 \$ | 0.7668 \$ | Y
 LESOTHO | 0.7845 \$ | 1.153 \$ | Y
 LITHUANIA | 1.8394 \$ | 1.479 \$ | Y
 LUXEMBOURG | 0.3562 \$ | 0.3832 \$ | Y
 LATVIA | 2.1202 \$ | 2.4842 \$ | Y
 LIBYA | 0.6169 \$ | 0.4497 \$ | Y
 MOROCCO | 0.5183 \$ | 2.132 \$ | Y
 MONACO | 0.8023 \$ | 2.1247 \$ | Y
 MOLDOVA, REPUBLIC OF | 0.4672 \$ | 0.4992 \$ | Y
 MONTENEGRO | 0.3536 \$ | 0.8558 \$ | Y
 MADAGASCAR | 1.0043 \$ | 1.0901 \$ | Y
 MARSHALL ISLANDS | 0.4046 \$ | 0.4046 \$ | Y
 NORTH MACEDONIA | 0.6601 \$ | 1.5052 \$ | Y
 MALI | 0.5561 \$ | 0.6258 \$ | Y
 MYANMAR | 0.2574 \$ | 0.355 \$ | Y
 MONGOLIA | 0.0699 \$ | 0.05 \$ | Y
 MACAU SAR | 0.4726 \$ | 0.4726 \$ | Y
 NORTHERN MARIANA ISLANDS | 0.0343 \$ | 0.0343 \$ | Y
 MARTINIQUE | 0.0465 \$ | 0.1033 \$ | Y
 MAURITANIA | 0.8688 \$ | 1.0065 \$ | Y
 MONTSERRAT | 1.2006 \$ | 1.2006 \$ | Y
 MALTA | 0.3331 \$ | 0.6612 \$ | Y
 MAURITIUS | 0.717 \$ | 0.6363 \$ | Y
 MALDIVES | 5.702 \$ | 5.702 \$ | Y
 MALAWI | 0.7964 \$ | 0.677 \$ | Y
 MEXICO | 0.0501 \$ | 0.1711 \$ | Y
 MOZAMBIQUE | 0.2722 \$ | 0.4588 \$ | Y
 NAMIBIA | 0.2139 \$ | 0.1839 \$ | Y
 NEW CALEDONIA | 0.975 \$ | 0.4491 \$ | Y
 NIGER | 0.7102 \$ | 0.5895 \$ | Y
 NORFOLK ISLAND | 2.1209 \$ | 1.065 \$ | Y
 NIGERIA | 0.6428 \$ | 0.6428 \$ | Y
 NICARAGUA | 0.1902 \$ | 0.3507 \$ | Y
 NORWAY | 0.0338 \$ | 0.1522 \$ | Y
 NEPAL | 0.5329 \$ | 0.5329 \$ | Y
 NAURU | 1.8562 \$ | 2.026 \$ | Y
 NIUE | 1.7966 \$ | 1.3181 \$ | Y
 PERU | 0.0487 \$ | 0.1476 \$ | Y
 FRENCH POLYNESIA | 0.411 \$ | 0.5337 \$ | Y
 PAPUA NEW GUINEA | 0.9428 \$ | 1.3329 \$ | Y
 PAKISTAN | 0.5737 \$ | 0.5737 \$ | Y
 SAINT PIERRE AND MIQUELON | 0.5816 \$ | 0.5816 \$ | Y
 PUERTO RICO | 0.0242 \$ | 0.0242 \$ | Y
 PALESTINE, STATE OF | 0.2667 \$ | 0.3118 \$ | Y
 PALAU | 0.4532 \$ | 0.4417 \$ | Y
 PARAGUAY | 0.1531 \$ | 0.2971 \$ | Y

QATAR | 0.8432 \$ | 0.8784 \$ | Y
 SERBIA | 0.2929 \$ | 0.4437 \$ | Y
 RWANDA | 1.103 \$ | 1.2498 \$ | Y
 SAUDI ARABIA | 0.3749 \$ | 0.5608 \$ | Y
 SOLOMON ISLANDS | 0.975 \$ | 1.9255 \$ | Y
 SEYCHELLES | 1.1088 \$ | 1.0784 \$ | Y
 SWEDEN | 0.0234 \$ | 0.0956 \$ | Y
 SAINT HELENA, ASCENSION AND TRISTAN DA CUNHA |
 2.4267 \$ | 2.3385 \$ | Y
 SLOVAKIA | 0.0701 \$ | 0.4768 \$ | Y
 SIERRA LEONE | 0.8439 \$ | 0.7772 \$ | Y
 SAN MARINO | 0.8929 \$ | 0.3148 \$ | Y
 SENEGAL | 0.7273 \$ | 0.8951 \$ | Y
 SOMALIA | 0.7888 \$ | 0.7763 \$ | Y
 SURINAME | 0.1996 \$ | 0.4533 \$ | Y
 SOUTH SUDAN | 0.6542 \$ | 0.7173 \$ | Y
 SAO TOME AND PRINCIPE | 1.5976 \$ | 1.574 \$ | Y
 EL SALVADOR | 0.8294 \$ | 0.6228 \$ | Y
 SINT MAARTEN (DUTCH PART) | 0.4137 \$ | 0.4678 \$ | Y
 ESWATINI | 0.2293 \$ | 0.2666 \$ | Y
 TURKS AND CAICOS ISLANDS | 1.411 \$ | 1.6546 \$ | Y
 CHAD | 0.83 \$ | 0.8565 \$ | Y
 FRENCH SOUTHERN TERRITORIES | 0.023 \$ | 0.1601 \$ | Y
 TOGO | 0.5079 \$ | 0.4711 \$ | Y
 THAILAND | 0.1271 \$ | 0.1271 \$ | Y
 TAJIKISTAN | 0.2603 \$ | 0.2817 \$ | Y
 TOKELAU | 0.975 \$ | 2.4545 \$ | Y
 TIMOR-LESTE | 0.975 \$ | 0.9269 \$ | Y
 TURKMENISTAN | 0.435 \$ | 0.435 \$ | Y
 TUNISIA | 1.2254 \$ | 1.2586 \$ | Y
 TONGA | 1.4663 \$ | 1.513 \$ | Y
 TURKEY | 0.2271 \$ | 0.5803 \$ | Y
 TRINIDAD AND TOBAGO | 0.5075 \$ | 0.6433 \$ | Y
 TAIWAN, CHINA | 0.0741 \$ | 0.4129 \$ | Y
 TANZANIA, UNITED REPUBLIC OF | 1.6103 \$ | 1.6103 \$ | Y
 UGANDA | 1.6086 \$ | 1.6086 \$ | Y
 UNITED STATES MINOR OUTLYING ISLANDS | 0.0343 \$ |
 0.0343 \$ | Y
 UNITED STATES OF AMERICA | 0.0318 \$ | 0.0318 \$ | Y
 UZBEKISTAN | 0.3047 \$ | 0.3047 \$ | Y
 SAINT VINCENT AND THE GRENADINES | 0.9717 \$ | 0.5279 \$ |
 Y
 VIRGIN ISLANDS (BRITISH) | 0.4557 \$ | 0.4557 \$ | Y
 VIET NAM | 0.3142 \$ | 0.3142 \$ | Y
 VANUATU | 1.326 \$ | 1.4891 \$ | Y
 WALLIS AND FUTUNA | 0.975 \$ | 0.975 \$ | Y
 SAMOA | 0.3329 \$ | 0.9589 \$ | Y
 YEMEN | 0.2885 \$ | 0.2296 \$ | Y
 MAYOTTE | 0.2471 \$ | 0.4199 \$ | Y
 SOUTH AFRICA | 0.3844 \$ | 0.6876 \$ | Y
 ZAMBIA | 0.747 \$ | 0.7075 \$ | Y
 ZIMBABWE | 0.3413 \$ | 0.6389 \$ | Y

Accepted and agreed as of the date specified below by the authorized representative of Customer

Signature:
Print Name:
Date:
Zoom Service Effective Date: 05/22/2023
PO # (If Applicable):
VAT # (If Applicable):
TAN # (If Applicable):
CIN # (If Applicable):

Zoom reserves the right at its sole discretion to accept Order Forms received after the Valid Until date.

If a PO# is required for processing the invoice related to this order, please provide a PO with this order. If issuance of PO is delayed, please provide a PO within 5 days of the service effective date via email to purchase-orders@zoomus.zendesk.com. Notwithstanding the foregoing, the period for payment shall commence as of the applicable invoice date. Such payment period shall not restart based on any delays in issuing a Purchase Order or any procurement process.

Zoom Phone services provided by Zoom Voice Communications, Inc. Rates, terms and conditions for Zoom Phone services are set by Zoom Voice Communications, Inc.



Thank you for choosing CDW. We have received your quote.

Hardware Software Services IT Solutions Brands Research Hub

Review and Complete Purchase

SANDI KERKHOFF,

Thank you for considering CDW•G for your technology needs. The details of your quote are below. **If you are an eProcurement or single sign on customer, please log into your system to access the CDW site.** You can search for your quote to retrieve and transfer back into your system for processing.

For all other customers, click below to convert your quote to an order.

Convert Quote to Order

QUOTE #	QUOTE DATE	QUOTE REFERENCE	CUSTOMER #	GRAND TOTAL
NKMN654	6/2/2023	POLY UPDTED	8446860	\$33,333.45

QUOTE DETAILS				
ITEM	QTY	CDW#	UNIT PRICE	EXT. PRICE
Poly Edge E450 - VoIP phone with caller ID call waiting - 3-way call capabi Mfg. Part#: 2200-87030-025 Contract: Nebraska ESU Cooperative Purchasing (022-G)	5	7143298	\$196.24	\$981.20
Poly Savi 8220 UC - Standard - wireless headset system Mfg. Part#: 209215-01 Contract: Nebraska ESU Cooperative Purchasing (022-G)	3	5906209	\$232.00	\$696.00
Poly CS540 - Wireless Headset Mfg. Part#: 84693-01 UNSPSC: 52161514 Contract: Nebraska ESU Cooperative Purchasing (022-G)	3	2468326	\$232.00	\$696.00
Poly Studio X70 - video conferencing kit - with Poly TC8 Mfg. Part#: 7200-87300-001 Contract: Nebraska ESU Cooperative Purchasing (022-G)	1	6690401	\$4,521.76	\$4,521.76
Poly Studio X50 - Video Conferencing Kit - with Poly TC8 Mfg. Part#: 2200-86270-001 Contract: Nebraska ESU Cooperative Purchasing (022-G)	2	5825403	\$2,456.57	\$4,913.14
Poly - expansion module Mfg. Part#: 2200-87020-025 Contract: Nebraska ESU Cooperative Purchasing (022-G)	5	7143297	\$148.19	\$740.95
Poly CCX 600 OpenSIP - VoIP phone Mfg. Part#: 2200-49780-025 Contract: Nebraska ESU Cooperative Purchasing (022-G)	25	6198791	\$400.00	\$10,000.00

QUOTE DETAILS (CONT.)

[Poly Edge E220 - VoIP phone with caller ID call waiting - 3-way call capabi](#) 110 7143294 \$98.04 \$10,784.40

Mfg. Part#: 2200-86990-025

Contract: Nebraska ESU Cooperative Purchasing (022-G)

SUBTOTAL	\$33,333.45
SHIPPING	\$0.00
SALES TAX	\$0.00
GRAND TOTAL	\$33,333.45

PURCHASER BILLING INFO

Billing Address:
DOUGLAS COUNTY WEST COMMUNITY SCHOO
ACCOUNTS PAYABLE
PO BOX 378
BOARD OF EDUCATION
VALLEY, NE 68064-0378
Phone: (402) 359-2583
Payment Terms: NET 30 Days-Govt/Ed

DELIVER TO

Shipping Address:
DOUGLAS COUNTY WEST COMMUNITY SCHOO
SANDI KERKHOFF
PO BOX 378
BOARD OF EDUCATION
VALLEY, NE 68064-0378
Phone: (402) 359-2583
Shipping Method:

Please remit payments to:

CDW Government
75 Remittance Drive
Suite 1515
Chicago, IL 60675-1515



Sales Contact Info

Nick Schultz (K-12) | (312) 547-5027 | nischul@cdwg.com

LEASE OPTIONS

FMV TOTAL	FMV LEASE OPTION	BO TOTAL	BO LEASE OPTION
\$33,333.45	\$901.67/Month	\$33,333.45	\$1,039.00/Month

Monthly payment based on 36 month lease. Other terms and options are available. Contact your Account Manager for details. Payment quoted is subject to change.

Why finance?

- Lower Upfront Costs. Get the products you need without impacting cash flow. Preserve your working capital and existing credit line.
- Flexible Payment Terms. 100% financing with no money down, payment deferrals and payment schedules that match your company's business cycles.
- Predictable, Low Monthly Payments. Pay over time. Lease payments are fixed and can be tailored to your budget levels or revenue streams.
- Technology Refresh. Keep current technology with minimal financial impact or risk. Add-on or upgrade during the lease term and choose to return or purchase the equipment at end of lease.
- Bundle Costs. You can combine hardware, software, and services into a single transaction and pay for your software licenses over time! We know your challenges and understand the need for flexibility.

General Terms and Conditions:

This quote is not legally binding and is for discussion purposes only. The rates are estimate only and are based on a collection of industry data from numerous sources. All rates and financial quotes are subject to final review, approval, and documentation by our leasing partners. Payments above exclude all applicable taxes. Financing is subject to credit approval and review of final equipment and services configuration. Fair Market Value leases are structured with the assumption that the equipment has a residual value at the end of the lease term.



Order Form Number: Q2128716
Valid Until: 07/01/2023

Zoom Video Communications Inc. ('Zoom')
 55 Almaden Blvd, 6th Floor
 San Jose, CA

<p>Billed To</p> <p>Customer: DC West Community Schools Account Legal Name: DC West Community Schools Contact Name: Zoom Admin 401 S Pine St, PO Box 378 Valley, Nebraska 68064, United States Email Address: zoom@dcwest.org Phone: 4023592583</p>	<p>Sold To</p> <p>Customer: DC West Community Schools Account Legal Name: DC West Community Schools Contact Name: Zoom Admin 401 S Pine St, PO Box 378 Valley, Nebraska 68064, United States Email Address: zoom@dcwest.org Phone: 4023592583</p>
<p>Auto Renew: Yes Initial Paid Subscription Term: 36 Month Renewal Subscription Term: 36 Month Paid Period Start Date: 06/01/2023</p>	<p>Billing Method: Email Currency: USD Payment Term: Net 30</p>

This Zoom Order Form and any other Order Forms that reference this Order Form are governed by the Zoom Terms of Service found at <http://www.zoom.us/terms> (unless Customer and Zoom have entered a written governing Master Subscription Agreement, in which case such written agreement will govern).

SERVICE	BILLING PERIOD	QUANTITY	PRICE	TOTAL
Education Annual	Annual	20	USD 6.00	USD 120.00
Zoom Phone Common Area Monthly	Month	6	USD 4.00	USD 24.00
Zoom Phone US/Canada Phone Numbers Monthly	Month	3	USD 5.00	USD 15.00
Zoom Phone US/Canada Unlimited Calling Named User Monthly	Month	130	USD 8.00	USD 1,040.00
Zoom Phone Monthly Usage - overage fee	Month	NA	NA	NA
Zoom Phone Pay As You Go	Month	1	USD 0.00	USD 0.00
Zoom Rooms Monthly	Month	1	USD 49.00	USD 49.00

(Before Taxes)	
Monthly Payment:	USD 1,128.00
Annual Payment:	USD 120.00

Payment Schedule Summary (Before Taxes)
<p>First Payment: USD 1,248.00</p> <p>Monthly Recurring Payment: USD 1,128.00 (Starting from the Second Month) Annual Recurring Payment: USD 120.00 (At the beginning of the Second Year)</p>

Named Host - means any subscribed host who may host an unlimited number of meetings during the Term using the Service. Any meeting will have at least one Named Host. Unless Customer has purchased an extended capacity, the number of participants (participants do not require a subscription) will not exceed 300 per meeting. Named Host subscription may not be shared or used by anyone other than the individual to whom the Named Host subscription is assigned.

Zoom EDU subscriptions are intended for student and faculty and pedagogical interaction within a classroom environment, or the administration thereof and may not be used for any commercial purpose. Zoom EDU subscriptions may not be purchased by hospitals, medical centers, clinics, or other affiliated organizations not specifically involving student and faculty and pedagogical interactions within a classroom environment or the administration thereof. Country or region availability for Zoom Phone is listed on Zoom's website and is subject to change (see <https://explore.zoom.us/docs/en-us/zoomphone/global-coverage.html>).

Fees - The fees for the Services, if any, are described in the Order Form. The actual fees may also include overage amounts or per use charges for audio and/or cloud recording in addition to the fees in the Order, if such use is higher than the amounts described in the Order, and you agree to pay these amounts or charges if you incur them. Invoicing for Services begins on the first day that the service is available for use by the Customer and monthly thereafter for the duration Term, except for annual pre-pay option which is invoiced once in the first month of the annual term. Amendment orders will co-term with the existing subscription term end date. Invoices are pro-rated from paid period start date to base subscription end date. Purchase order, if any, issued in connection with this order should reference the above order form number. Commitments not utilized by the Customer during the month for which they are committed may not be carried forward into any subsequent month or term.

All prices shown for Zoom and Zoom Phone services are exclusive of taxes. The term 'taxes' referred herein should encompass: US state and local taxes, VAT, GST, HST (or any other consumption taxes), Digital Service Taxes and Withholding Taxes that may apply upon making payments to Zoom. Regulatory telecommunications fees, such as USF or any similar foreign fee, will apply to Zoom Phone services and details of taxes and fees will be included in issued invoices.

Professional Services, if purchased, will be presented in a separate Order Form.

Zoom Phone Rates

Zoom Phone Table Format: Country | Landline Rate | Mobile Rate | Enabled Status

Y means Zoom Phone for country is Enabled upon provisioning

N means Zoom Phone for country is Not Enabled upon provisioning

Toll-Free	Callout
Country Landline Rate Mobile Rate Enabled Status	Country Landline Rate Mobile Rate Enabled Status
Not Applicable	ANTIGUA AND BARBUDA 1.0218 \$ 1.0486 \$ Y ARGENTINA 0.1156 \$ 0.5623 \$ Y AUSTRIA 0.0501 \$ 0.23 \$ Y BULGARIA 0.1186 \$ 0.8406 \$ Y BOLIVIA (PLURINATIONAL STATE OF) 0.5155 \$ 0.8003 \$ Y BONAIRE, SINT EUSTATIUS AND SABA 0.7028 \$ 0.7028 \$ Y BOTSWANA 0.436 \$ 0.9398 \$ Y COCOS (KEELING) ISLANDS 0.4552 \$ 0 \$ Y SWITZERLAND 0.3694 \$ 0.7011 \$ Y CURAÇAO 0.2813 \$ 0.7028 \$ Y CHRISTMAS ISLAND 0.4552 \$ 0 \$ Y CYPRUS 0.0953 \$ 0.2861 \$ Y GERMANY 0.0353 \$ 0.1434 \$ Y DOMINICAN REPUBLIC 0.1716 \$ 0.3824 \$ Y ALGERIA 0.3773 \$ 2.1167 \$ Y ECUADOR 0.5392 \$ 0.7572 \$ Y WESTERN SAHARA 0.5182 \$ 0 \$ Y SPAIN 0.0381 \$ 0.1832 \$ Y FINLAND 0.8584 \$ 0.864 \$ Y GRENADA 1.0196 \$ 1.2758 \$ Y GREECE 0.0911 \$ 0.3357 \$ Y HONG KONG SAR 0.0863 \$ 0.1333 \$ Y
64	

INDONESIA | 0.1486 \$ | 0.2407 \$ | Y
 ISRAEL | 0.0639 \$ | 0.1161 \$ | Y
 INDIA | 0.0915 \$ | 0.0837 \$ | Y
 JORDAN | 0.6552 \$ | 0.8567 \$ | Y
 KENYA | 0.9342 \$ | 0.7235 \$ | Y
 CAYMAN ISLANDS | 0.7259 \$ | 0.4934 \$ | Y
 KAZAKHSTAN | 0.3587 \$ | 0.6853 \$ | Y
 SAINT LUCIA | 0.9581 \$ | 0.5276 \$ | Y
 MALAYSIA | 0.1001 \$ | 0.0918 \$ | Y
 NETHERLANDS | 0.0913 \$ | 0.4453 \$ | Y
 NEW ZEALAND | 0.0567 \$ | 0.2556 \$ | Y
 OMAN | 0.5335 \$ | 1.1352 \$ | Y
 PANAMA | 0.0485 \$ | 0.994 \$ | Y
 PHILIPPINES | 0.5808 \$ | 0.7074 \$ | Y
 POLAND | 0.137 \$ | 0.3728 \$ | Y
 PORTUGAL | 0.026 \$ | 0.1545 \$ | Y
 RÉUNION | 0.3569 \$ | 0.6072 \$ | Y
 ROMANIA | 0.0812 \$ | 0.2815 \$ | Y
 RUSSIAN FEDERATION | 0.1054 \$ | 0.8892 \$ | Y
 SINGAPORE | 0.0329 \$ | 0.0335 \$ | Y
 SLOVENIA | 0.1855 \$ | 1.1228 \$ | Y
 UKRAINE | 0.5868 \$ | 1.0755 \$ | Y
 URUGUAY | 0.2285 \$ | 0.8432 \$ | Y
 HOLY SEE (VATICAN CITY) | 0.0082 \$ | 0 \$ | Y
 VENEZUELA (BOLIVARIAN REPUBLIC OF) | 0.0518 \$ | 0.2809 \$ | Y
 VIRGIN ISLANDS (U.S.) | 0.9646 \$ | 1.5308 \$ | Y
 ASCENSION ISLAND | 1.8943 \$ | 1.065 \$ | Y
 ANDORRA | 0.1589 \$ | 0.348 \$ | Y
 UNITED ARAB EMIRATES | 0.6535 \$ | 0.6535 \$ | Y
 AFGHANISTAN | 0.3124 \$ | 0.3766 \$ | Y
 ANGUILLA | 1.0442 \$ | 1.0442 \$ | Y
 ALBANIA | 0.2534 \$ | 0.7026 \$ | Y
 ARMENIA | 0.3098 \$ | 0.3455 \$ | Y
 NETHERLANDS ANTILLES | 0.1956 \$ | 0.15 \$ | Y
 ANGOLA | 0.6882 \$ | 0.5871 \$ | Y
 AMERICAN SAMOA | 0.3267 \$ | 0.3267 \$ | Y
 AUSTRALIA | 0.0443 \$ | 0.182 \$ | Y
 ARUBA | 0.1557 \$ | 0.3294 \$ | Y
 AZERBAIJAN | 0.434 \$ | 0.5256 \$ | Y
 BOSNIA AND HERZEGOVINA | 0.6177 \$ | 1.313 \$ | Y
 BARBADOS | 0.972 \$ | 1.0238 \$ | Y
 BANGLADESH | 0.1703 \$ | 0.1697 \$ | Y
 BELGIUM | 0.308 \$ | 0.5272 \$ | Y
 BURKINA FASO | 0.5944 \$ | 0.6532 \$ | Y
 BAHRAIN | 0.4356 \$ | 0.5154 \$ | Y
 BURUNDI | 0.788 \$ | 0.8907 \$ | Y
 BENIN | 0.602 \$ | 0.5223 \$ | Y
 BERMUDA | 0.3216 \$ | 0.3216 \$ | Y
 BRUNEI DARUSSALAM | 0.1424 \$ | 0.0558 \$ | Y
 BRAZIL | 0.0524 \$ | 0.2582 \$ | Y
 BAHAMAS | 0.6278 \$ | 0.6278 \$ | Y
 BHUTAN | 0.1257 \$ | 0.1025 \$ | Y
 BELARUS | 0.6629 \$ | 0.6641 \$ | Y
 BELIZE | 1.533 \$ | 1.533 \$ | Y
 CANADA | 0.0355 \$ | 0.0355 \$ | Y
 CONGO, DEMOCRATIC REPUBLIC OF THE | 0.867 \$ | 0.7109 \$ | Y
 CENTRAL AFRICAN REPUBLIC | 1.0972 \$ | 0.8121 \$ | Y
 COTE D'IVOIRE | 0.67 \$ | 0.7129 \$ | Y
 COOK ISLANDS | 1.5994 \$ | 1.3205 \$ | Y
 CHILE | 0.1132 \$ | 0.5309 \$ | Y
 CAMEROON | 0.4107 \$ | 0.5179 \$ | Y
 CHINA | 0.0395 \$ | 0.0395 \$ | Y
 COLOMBIA | 0.117 \$ | 0.1003 \$ | Y
 COSTA RICA | 0.1231 \$ | 0.3139 \$ | Y
 CABO VERDE | 0.5317 \$ | 0.3612 \$ | Y
 CZECHIA | 0.113 \$ | 0.2348 \$ | Y
 DIEGO GARCIA | 0.435 \$ | 0.435 \$ | Y
 DJIBOUTI | 0.7215 \$ | 0.5718 \$ | Y
 DENMARK | 0.0327 \$ | 0.1404 \$ | Y
 DOMINICA | 1.0227 \$ | 0.7727 \$ | Y
 ESTONIA | 2.1381 \$ | 2.0891 \$ | Y
 EGYPT | 0.4326 \$ | 0.6226 \$ | Y
 ERITREA | 0.7029 \$ | 0.4078 \$ | Y
 ETHIOPIA | 0.4027 \$ | 0.3803 \$ | Y
 FIJI | 1.5038 \$ | 0.7631 \$ | Y
 FALKLAND ISLANDS (MALVINAS) | 1.9702 \$ | 1.9702 \$ | Y
 MICRONESIA (FEDERATED STATES OF) | 0.8686 \$ | 0.8308 \$ | Y
 FAROE ISLANDS | 0.1524 \$ | 0.0288 \$ | Y
 FRANCE | 0.0329 \$ | 0.126 \$ | Y

GABON | 0.6246 \$ | 0.6921 \$ | Y
 UNITED KINGDOM | 0.0233 \$ | 0.0682 \$ | Y
 GEORGIA | 0.8426 \$ | 1.1833 \$ | Y
 FRENCH GUIANA | 0.2043 \$ | 0.1204 \$ | Y
 GUERNSEY | 0.0233 \$ | 0.0682 \$ | Y
 GHANA | 1.1366 \$ | 1.1366 \$ | Y
 GIBRALTAR | 0.2334 \$ | 0.9396 \$ | Y
 GREENLAND | 1.125 \$ | 0.3228 \$ | Y
 GAMBIA | 0.6642 \$ | 0.801 \$ | Y
 GUINEA | 1.1618 \$ | 0.9137 \$ | Y
 GUADELOUPE | 0.0265 \$ | 0.1017 \$ | Y
 EQUATORIAL GUINEA | 2.7398 \$ | 2.7398 \$ | Y
 GUATEMALA | 0.625 \$ | 0.7812 \$ | Y
 GUAM | 0.0409 \$ | 0.0409 \$ | Y
 GUINEA-BISSAU | 0.8951 \$ | 0.9941 \$ | Y
 GUYANA | 0.333 \$ | 0.3282 \$ | Y
 HONDURAS | 0.1846 \$ | 0.2305 \$ | Y
 CROATIA | 0.458 \$ | 1.251 \$ | Y
 HAITI | 0.3532 \$ | 0.4437 \$ | Y
 HUNGARY | 0.1209 \$ | 0.2156 \$ | Y
 IRELAND | 0.0256 \$ | 0.1784 \$ | Y
 ISLE OF MAN | 0.0233 \$ | 0.0682 \$ | Y
 IRAQ | 0.2409 \$ | 0.2955 \$ | Y
 ICELAND | 0.2305 \$ | 0.1054 \$ | Y
 ITALY | 0.0338 \$ | 0.2172 \$ | Y
 JERSEY | 0.0233 \$ | 0.0682 \$ | Y
 JAMAICA | 1.0442 \$ | 1.0442 \$ | Y
 JAPAN | 0.0601 \$ | 0.137 \$ | Y
 KYRGYZSTAN | 0.2141 \$ | 0.3367 \$ | Y
 CAMBODIA | 0.3497 \$ | 0.3497 \$ | Y
 KIRIBATI | 1.9284 \$ | 2.1749 \$ | Y
 COMOROS | 0.6617 \$ | 0.7148 \$ | Y
 SAINT KITTS AND NEVIS | 0.9292 \$ | 0.9292 \$ | Y
 KOREA, REPUBLIC OF | 0.1029 \$ | 0.1029 \$ | Y
 KUWAIT | 0.3625 \$ | 0.3625 \$ | Y
 LAO PEOPLE'S DEMOCRATIC REPUBLIC | 0.2884 \$ | 0.1503 \$ | Y
 Y
 LEBANON | 0.1964 \$ | 0.2401 \$ | Y
 LIECHTENSTEIN | 0.4236 \$ | 0.213 \$ | Y
 SRI LANKA | 0.6953 \$ | 0.6953 \$ | Y
 LIBERIA | 0.7744 \$ | 0.7668 \$ | Y
 LESOTHO | 0.7845 \$ | 1.153 \$ | Y
 LITHUANIA | 1.8394 \$ | 1.479 \$ | Y
 LUXEMBOURG | 0.3562 \$ | 0.3832 \$ | Y
 LATVIA | 2.1202 \$ | 2.4842 \$ | Y
 LIBYA | 0.6169 \$ | 0.4497 \$ | Y
 MOROCCO | 0.5183 \$ | 2.132 \$ | Y
 MONACO | 0.8023 \$ | 2.1247 \$ | Y
 MOLDOVA, REPUBLIC OF | 0.4672 \$ | 0.4992 \$ | Y
 MONTENEGRO | 0.3536 \$ | 0.8558 \$ | Y
 MADAGASCAR | 1.0043 \$ | 1.0901 \$ | Y
 MARSHALL ISLANDS | 0.4046 \$ | 0.4046 \$ | Y
 NORTH MACEDONIA | 0.6601 \$ | 1.5052 \$ | Y
 MALI | 0.5561 \$ | 0.6258 \$ | Y
 MYANMAR | 0.2574 \$ | 0.355 \$ | Y
 MONGOLIA | 0.0699 \$ | 0.05 \$ | Y
 MACAU SAR | 0.4726 \$ | 0.4726 \$ | Y
 NORTHERN MARIANA ISLANDS | 0.0343 \$ | 0.0343 \$ | Y
 MARTINIQUE | 0.0465 \$ | 0.1033 \$ | Y
 MAURITANIA | 0.8688 \$ | 1.0065 \$ | Y
 MONTSERRAT | 1.2006 \$ | 1.2006 \$ | Y
 MALTA | 0.3331 \$ | 0.6612 \$ | Y
 MAURITIUS | 0.717 \$ | 0.6363 \$ | Y
 MALDIVES | 5.702 \$ | 5.702 \$ | Y
 MALAWI | 0.7964 \$ | 0.677 \$ | Y
 MEXICO | 0.0501 \$ | 0.1711 \$ | Y
 MOZAMBIQUE | 0.2722 \$ | 0.4588 \$ | Y
 NAMIBIA | 0.2139 \$ | 0.1839 \$ | Y
 NEW CALEDONIA | 0.975 \$ | 0.4491 \$ | Y
 NIGER | 0.7102 \$ | 0.5895 \$ | Y
 NORFOLK ISLAND | 2.1209 \$ | 1.065 \$ | Y
 NIGERIA | 0.6428 \$ | 0.6428 \$ | Y
 NICARAGUA | 0.1902 \$ | 0.3507 \$ | Y
 NORWAY | 0.0338 \$ | 0.1522 \$ | Y
 NEPAL | 0.5329 \$ | 0.5329 \$ | Y
 NAURU | 1.8562 \$ | 2.026 \$ | Y
 NIUE | 1.7966 \$ | 1.3181 \$ | Y
 PERU | 0.0487 \$ | 0.1476 \$ | Y
 FRENCH POLYNESIA | 0.411 \$ | 0.5337 \$ | Y
 PAPUA NEW GUINEA | 0.9428 \$ | 1.3329 \$ | Y
 PAKISTAN | 0.5737 \$ | 0.5737 \$ | Y
 SAINT PIERRE AND MIQUELON | 0.5816 \$ | 0.5816 \$ | Y

PUERTO RICO | 0.0242 \$ | 0.0242 \$ | Y
 PALESTINE, STATE OF | 0.2667 \$ | 0.3118 \$ | Y
 PALAU | 0.4532 \$ | 0.4417 \$ | Y
 PARAGUAY | 0.1531 \$ | 0.2971 \$ | Y
 QATAR | 0.8432 \$ | 0.8784 \$ | Y
 SERBIA | 0.2929 \$ | 0.4437 \$ | Y
 RWANDA | 1.103 \$ | 1.2498 \$ | Y
 SAUDI ARABIA | 0.3749 \$ | 0.5608 \$ | Y
 SOLOMON ISLANDS | 0.975 \$ | 1.9255 \$ | Y
 SEYCHELLES | 1.1088 \$ | 1.0784 \$ | Y
 SWEDEN | 0.0234 \$ | 0.0956 \$ | Y
 SAINT HELENA, ASCENSION AND TRISTAN DA CUNHA |
 2.4267 \$ | 2.3385 \$ | Y
 SLOVAKIA | 0.0701 \$ | 0.4768 \$ | Y
 SIERRA LEONE | 0.8439 \$ | 0.7772 \$ | Y
 SAN MARINO | 0.8929 \$ | 0.3148 \$ | Y
 SENEGAL | 0.7273 \$ | 0.8951 \$ | Y
 SOMALIA | 0.7888 \$ | 0.7763 \$ | Y
 SURINAME | 0.1996 \$ | 0.4533 \$ | Y
 SOUTH SUDAN | 0.6542 \$ | 0.7173 \$ | Y
 SAO TOME AND PRINCIPE | 1.5976 \$ | 1.574 \$ | Y
 EL SALVADOR | 0.8294 \$ | 0.6228 \$ | Y
 SINT MAARTEN (DUTCH PART) | 0.4137 \$ | 0.4678 \$ | Y
 ESWATINI | 0.2293 \$ | 0.2666 \$ | Y
 TURKS AND CAICOS ISLANDS | 1.411 \$ | 1.6546 \$ | Y
 CHAD | 0.83 \$ | 0.8565 \$ | Y
 FRENCH SOUTHERN TERRITORIES | 0.023 \$ | 0.1601 \$ | Y
 TOGO | 0.5079 \$ | 0.4711 \$ | Y
 THAILAND | 0.1271 \$ | 0.1271 \$ | Y
 TAJIKISTAN | 0.2603 \$ | 0.2817 \$ | Y
 TOKELAU | 0.975 \$ | 2.4545 \$ | Y
 TIMOR-LESTE | 0.975 \$ | 0.9269 \$ | Y
 TURKMENISTAN | 0.435 \$ | 0.435 \$ | Y
 TUNISIA | 1.2254 \$ | 1.2586 \$ | Y
 TONGA | 1.4663 \$ | 1.513 \$ | Y
 TURKEY | 0.2271 \$ | 0.5803 \$ | Y
 TRINIDAD AND TOBAGO | 0.5075 \$ | 0.6433 \$ | Y
 TAIWAN, CHINA | 0.0741 \$ | 0.4129 \$ | Y
 TANZANIA, UNITED REPUBLIC OF | 1.6103 \$ | 1.6103 \$ | Y
 UGANDA | 1.6086 \$ | 1.6086 \$ | Y
 UNITED STATES MINOR OUTLYING ISLANDS | 0.0343 \$ |
 0.0343 \$ | Y
 UNITED STATES OF AMERICA | 0.0318 \$ | 0.0318 \$ | Y
 UZBEKISTAN | 0.3047 \$ | 0.3047 \$ | Y
 SAINT VINCENT AND THE GRENADINES | 0.9717 \$ | 0.5279 \$ |
 Y
 VIRGIN ISLANDS (BRITISH) | 0.4557 \$ | 0.4557 \$ | Y
 VIET NAM | 0.3142 \$ | 0.3142 \$ | Y
 VANUATU | 1.326 \$ | 1.4891 \$ | Y
 WALLIS AND FUTUNA | 0.975 \$ | 0.975 \$ | Y
 SAMOA | 0.3329 \$ | 0.9589 \$ | Y
 YEMEN | 0.2885 \$ | 0.2296 \$ | Y
 MAYOTTE | 0.2471 \$ | 0.4199 \$ | Y
 SOUTH AFRICA | 0.3844 \$ | 0.6876 \$ | Y
 ZAMBIA | 0.747 \$ | 0.7075 \$ | Y
 ZIMBABWE | 0.3413 \$ | 0.6389 \$ | Y

Accepted and agreed as of the date specified below by the authorized representative of Customer

Signature:	
Print Name:	
Date:	
Zoom Service Effective Date: 06/01/2023	
PO # (If Applicable):	
VAT # (If Applicable):	
TAN # (If Applicable):	67

CIN # (If Applicable):

The Services will be activated within 48 hours of order signature or Zoom Service Effective Date, whichever is later.

Zoom reserves the right at its sole discretion to accept Order Forms received after the Valid Until date.

If a PO# is required for processing the invoice related to this order, please provide a PO with this order. If issuance of PO is delayed, please provide a PO within 5 days of the service effective date via email to purchase-orders@zoomus.zendesk.com. Notwithstanding the foregoing, the period for payment shall commence as of the applicable invoice date. Such payment period shall not restart based on any delays in issuing a Purchase Order or any procurement process.

Zoom Phone services provided by Zoom Voice Communications, Inc. Rates, terms and conditions for Zoom Phone services are set by Zoom Voice Communications, Inc.



DC West Community Schools

3CX Purchased Yealink

Quote #006800

Version 1



Prepared For

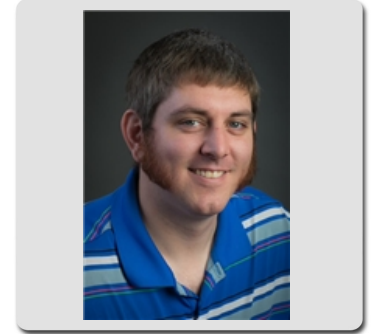

DC West Community Schools
 Sandi Kerkhoff
 401 S Pine St PO Box 378
 Valley, NE 68064
 skerkhoff@dcwest.org

Prepared By

Chris Walters
 Phone: 402-547-4310
 Email: cwalters@omahait.com



Phones/Headsets		Price	Qty	Extended
	<p>Yealink T57W</p> <ul style="list-style-type: none"> • 7" 800 x 480 capacitive adjustable touch screen • Adjustable LCD screen • Built-in Bluetooth 4.2 • Built-in dual band 2.4G/5G Wi-Fi (802.11a/b/g/n/ac) • USB 2.0 port for USB recording, wired/wireless USB headsets and EXP50 • Dual-port Gigabit Ethernet • Paperless label design 	\$250.00	5	\$1,250.00
	<p>Yealink EXP50</p> <ul style="list-style-type: none"> • 4.3" 272 x 480-pixel color screen • Color icons for rich visual experience • 20 physical keys on each page with dual-color LEDs • Three independent control keys with illuminated LED for fast switching pages • Supports up to 3 modules daisy-chain • Stand with 2 adjustable angles 	\$125.00	5	\$625.00

Phones/Headsets		Price	Qty	Extended
	<p>Yealink T54W</p> <ul style="list-style-type: none"> • 4.3" 480 x 272-pixel color display with backlight • Adjustable LCD screen • Built-in Bluetooth 4.2 • Built-in dual band 2.4G/5G Wi-Fi (802.11a/b/g/n/ac) • USB 2.0 port for USB recording, wired/wireless USB headsets and EXP50 • Dual-port Gigabit Ethernet • Paperless label design • Wall mountable <p>https://www.yealink.com/product/voice-communication-t54w</p>	\$195.00	25	\$4,875.00
	<p>Yealink T53</p> <ul style="list-style-type: none"> • 3.7" 360x160-pixel graphical LCD with backlight • Adjustable LCD screen • USB 2.0 port for USB recording, wired/wireless USB headsets, Wi-Fi/BT dongles, and EXP50 • Dual-port Gigabit Ethernet 	\$135.00	120	\$16,200.00
	<p>Yealink WH62 DECT Mono</p> <ul style="list-style-type: none"> • Yealink Acoustic Shield Technology • 2-ports USB 3.0 hub • Wireless range: up to 120m/394feet • Talk time: up to 13 hours • Standby time: 90 hours • Charging time: 2.5 hours (12V/2A) • Also available in Dual 	\$160.00	5	\$800.00

Phones/Headsets		Price	Qty	Extended
	Yealink WH63 DECT	\$175.00	5*	\$875.00
	<ul style="list-style-type: none"> • Yealink Acoustic Shield Technology • 2-ports USB 3.0 hub • Wireless range: up to 120m/394feet • Talk time: up to 8 hours • Standby time: 54 hours • Charging time: 2.5 hours (12V/2A) 			
Phones/Headsets Subtotal				\$23,750.00

Installation		Price	Qty	Extended
	3CX Installation Phone system build and configuration Server and SBC deployment Phone deployment Consult with networking team for VLAN assignments Phone service migration to new carrier End-User training Phone system administrator training Paging system integration	\$14,987.00	1	\$14,987.00
Installation Subtotal				\$14,987.00

Phone Server		Recurring	Price	Qty	Extended
	3CX Cloud hosted server	\$270.00	\$0.00	1	\$0.00
	3CX Cloud hosted server				
	3 Session border controllers (1 per building)				

Phone Server		Recurring	Price	Qty	Extended
3CX 24 Simultaneous call Professional		\$74.60	\$0.00	1	\$0.00
Microsoft 365 Integration					
Call Queues					
Auto Attendant					
Voicemail Transcription					
Chat & Call reports					
Call Recording					
SMS & MMS					
Video Conferencing (Up to 100 participants)					
Live Chat					
Phone Server Recurring Subtotal					\$344.60
Phone Server One-Time Subtotal					\$0.00

Phone Service		Recurring	Price	Qty	Extended
Monthly Voice Service Per Line 1-10		\$350.00	\$0.00	10	\$0.00
Included:					
Unlimited inbound/outbound Minutes (local and LD) at \$35 per line					

Phone Service		Recurring	Price	Qty	Extended
Monthly Voice Service Per Line 11-20 Included: Unlimited inbound/outbound Minutes (local and LD) at \$30 per line		\$300.00	\$0.00	10	\$0.00
Phone Service Recurring Subtotal					\$650.00
Phone Service One-Time Subtotal					\$0.00

Paging System		Price	Qty	Extended
	<p>CyberData SIP Paging Adapter</p> <ul style="list-style-type: none"> • Compatible with most analog amplifiers in the market • Supports audio prioritization, including 10 multicast paging groups • Loud/Night ringer function – second SIP extension • 9 user-uploadable page messages • Supports delayed pages with call buffering • Support for security code to prevent unwanted SIP calls • Can receive pages directly from Poly phones as well as other devices that can send standard multicast • Sense input capable of generating events or SIP calls • Built-in diagnostics • Line-in for background music • Line-out connector • Remote amp fault sensor • Audio controlled relay/remote amplifier enable • DTMF entries for analog paging zones • Rack mountable • TLS 1.2 (includes mutual authentication) and SRTP enhanced security for IP Endpoints in a local or cloud-based environment • HTTPS or HTTP web based configuration – HTTPS is enabled by default • Autoprovisioning via HTTPS, HTTP or TFTP • Configurable event generation for device health and status monitoring • 802.11q VLAN tagging • HTTP command interface 	\$525.00	3*	\$1,575.00
Paging System Subtotal				\$0.00

Service Contract	Recurring	Price	Qty	Extended
Service Agreement 5 hours of monthly service at \$125 each Can be 'banked' and used later with the banked time resetting on the annual anniversary of the contract start date Overage time billed at \$125 per hour If no service contract is desired, hourly time is available at \$150 per hour	\$625.00	\$0.00	5	\$0.00
Service Contract Recurring Subtotal				\$625.00
Service Contract One-Time Subtotal				\$0.00

Recap	Amount
Phones/Headsets	\$23,750.00
Installation	\$14,987.00
Phone Server	\$0.00
Phone Service	\$0.00
Paging System	\$0.00
Service Contract	\$0.00
Subtotal	\$38,737.00
Tax	\$2,711.59
Total	\$41,448.59

Recurring Expenses	Amount
Phone Server	\$344.60
Phone Service	\$650.00
Service Contract	\$625.00
Subtotal	\$1,619.60
Tax	\$113.37
Total	\$1,732.97

	None	Amount	None	Amount
	0	\$41,448.59	0	\$1,732.97

Taxes, shipping, handling and other fees may apply. We reserve the right to cancel orders arising from pricing or other errors.



Phone: (402) 571-9049

Email: travisw@voicendata.net

Web: www.voicendata.net



We have prepared a quote for you

Wildix Cloud IP Phone System Proposal

Quote # 000381
Version 1

Prepared for:

DC West Community Schools

Sandi Kerkhoff
skerkhoff@dcwest.org



Phone: (402) 571-9049
Email: travisw@voicendata.net
Web: www.voicendata.net

Monday, May 01, 2023

DC West Community Schools
Sandi Kerkhoff
P.O. Box 378
Valley, NE 68064
skerkhoff@dcwest.org

Dear Sandi,
Thank you for your interest in Voice & Data Systems, Inc.

A handwritten signature in black ink that reads "Travis Wells".

Travis Wells
Vice President
Voice & Data Systems Inc.



Phone: (402) 571-9049
 Email: travisw@voicendata.net
 Web: www.voicendata.net

Phones and Equipment

Qty	Product ID	Product Description
5	WIL-WelcomeConsole	Welcome Console desk phone
5	WIL-WelcomeConsole-EXT	Welcome Console desk phone expansion module/sidecar
120	WIL-WorkForce	Work Force desk phone
25	WIL-Vision	SIP Gigabit phone
3	WIL-PA	Paging Gateway and Intercom
		Subtotal: \$45,290.12

Professional Services/installation

Description	Price	Qty	Ext. Price
Labor to Program and Configure Phone System to Customer Specifications	\$100.00	60	\$6,000.00
		Subtotal:	\$6,000.00

Wildix Licensing

Qty	Description	
30	PBX Premium User Licenses Licenses	
120	PBX Basic User Licenses	
1	Phone System Monthly Support Agreement Fee	
		Monthly Subtotal: \$1,760.00



Phone: (402) 571-9049
 Email: travisw@voicendata.net
 Web: www.voicendata.net

Wildix Cloud IP Phone System Proposal



Prepared by:
Voice & Data Systems Inc.
 Travis Wells
 402-939-8141
 Fax (402) 991-9837
 travisw@voicendata.net

Prepared for:
DC West Community Schools
 P.O. Box 378
 Valley, NE 68064
 Sandi Kerkhoff
 (402) 359-2583
 skerkhoff@dcwest.org

Quote Information:
Quote #: 000381
 Version: 1
 Delivery Date: 05/01/2023
 Expiration Date: 06/30/2023

Quote Summary

Description	Amount
Phones and Equipment	\$45,290.12
Professional Services/installation	\$6,000.00
Subtotal:	\$51,290.12
Estimated Tax:	\$3,170.31
Total:	\$54,460.43

Monthly Recurring Summary

Description	Amount
Wildix Licensing	\$1,760.00
Monthly Subtotal:	\$1,760.00
Estimated Tax:	\$123.20
Monthly Total:	\$1,883.20

Taxes, shipping, handling and other fees may apply. We reserve the right to cancel orders arising from pricing or other errors.

Voice & Data Systems Inc.

DC West Community Schools

Signature: 
 Name: Travis Wells
 Title: Vice President
 Date: 05/01/2023

Signature: _____
 Name: Sandi Kerkhoff
 Date: _____



Note: This document is a proposal for services and should be viewed as an estimate of future costs. When ordering services Customer may request changes in quantities which can affect the estimated cost elements below.

Account Name: DC West Community Schools

Order Information	
Rate Sheet	Q131571
Revision	2
Created	4/27/2023
Valid Until	7/26/2023
Contract Term (months)	36

Partner Information	
Name	Voice & Data Technology Systems, Inc.
Account Manager	Travis Wells

Summary		
Site	Recurring	One-Time
401 S PINE ST VALLEY NE 68064	\$233.50	\$10.00
	Subtotal:	\$233.50
	Taxes:	\$52.72
	Total:	\$286.22

**Taxes are an estimate and may differ from actual invoices due to tax rate changes and actual services provided.*



Service Address

Address	401 S PINE ST	City	VALLEY
State	NEBRASKA	ZIP Code	68064

Products and Services

Product Name	Qty	Recurring	One-Time	Total Recurring	Total One-Time
Clearphone SIP Trunk	10	\$15.00	\$0.00	\$150.00	\$0.00
Clearphone Telephone Number	20	\$0.35	\$0.00	\$7.00	\$0.00
E911 Registration	2	\$1.00	\$0.00	\$2.00	\$0.00
IRDC Voice and Data Technologies	1	\$25.00	\$0.00	\$25.00	\$0.00
Local Number Port Order	1	\$0.00	\$10.00	\$0.00	\$10.00
Service Provider Recovery and Carrier Management Services	10	\$4.95	\$0.00	\$49.50	\$0.00
Total:				\$233.50	\$10.00

Rate Schedule

Name	Rate
Burst Calls	\$0.25
Clearphone SIP Trunk	\$15.00
Clearphone Telephone Number	\$0.35
E911 Registration	\$1.00
Local Number Port Order	\$10.00

6/5/2023

DC WEST COMMUNITY SCHOOLS
401 S PINE ST
VALLEY, NE 68064

Re: DC WEST COMMUNITY SCHOOLS, 401 S PINE ST, VALLEY

Standard Heating Air Conditioning, Inc. is pleased to quote the following:

MultiBidNumber: 1

Trane package unit YHD240F4RHA03H0A1C, 133210700D

Remove refrigerant from system

Replace evaporator coil

Replace stage one and stage two filter driers

Recharge system with refrigerant

Crane required to place coil on roof - we provide

\$34,700.82

*Evaporator coil replacement bid requested by customer; we did not diagnose.
Proposal assumes standard evaporator coil replacement.*

*Warranty for the evaporator coil would be one year. Warranty for the labor
would be 60 days.*

Lead time for evaporator coil is estimated at 35 days.

Total Base Bid: \$34,700.82

For jobs located in Iowa: Plus applicable taxes

HEIDI MAY

Inside Account Manager

Standard Heating and Air Conditioning, Inc.

Office: 402-339-6700

Direct: 402-339-8014 x359

Fax: 402-339-5809

heidim@standardac.com

Terms and Conditions

1. All labor is to be performed during Company's regular working hours, unless noted in this proposal.
2. Warranty work is performed during the Company's normal business hours, but can be performed after normal hours if Customer pays the difference between standard labor rate and overtime labor rate.
3. 50% down payment required on any special order equipment.
4. Unless noted in this proposal, payment is due in full upon completion of work. A finance charge of 1 ½% per month (18% annually) will be charged on all unpaid balances after 30 days from the invoice date.
5. In the event Customer's account must be referred to attorneys for collection, Customer agrees to pay all reasonable attorney fees, court costs and other collection costs.
6. Customer shall assume risk of loss or damage to equipment after it is sent in place on the job.
7. Every attempt will be made to complete the work on the date(s) specified, but because the Company may have no control over parts availability and delivery, all completion dates are estimates only.
8. The Company shall not be liable for damage, loss or delays resulting from fire, explosion, flooding, the elements or any other cause beyond our control.
9. The Company shall use ordinary care in performing all work, but shall not be liable for incidental or consequential damages, or for injuries to persons or damage to property except those directly caused by negligent acts of the Company's employees.
10. The Company shall not be responsible for any damages incurred due to inability of the building structure to properly support the installed equipment, or for expense incurred by removing, replacing or refinishing part of the building structure necessary for the performance of any service or installation, unless otherwise noted in the proposal.
11. The Company shall not be liable for any present and future taxes, charges or other governmental fees, or any items of equipment, labor or special tests required or recommended by insurance companies, equipment vendors or governmental authorities.
12. The Company shall not be liable for the identification, detection, abatement, encapsulation, storage, removal or transportation of any regulated or hazardous substances. Regulated or hazardous substances may include, but are not limited to asbestos, certain refrigerants and refrigerant oils. If any such products or materials are encountered during the course of work, the Company shall discontinue work until regulated or hazardous materials have been removed or liability is eliminated. The Company shall receive extension equal to the time of the delay to complete the work and reserves the right to be compensated for any loss due to a delay.
13. Replacement and/ or upgrades of the existing electrical service must be performed by a licensed electrical contractor and are not included unless noted in this proposal.
14. All material is guaranteed to be as specified. All work is to be completed in a workmanlike manner according to standard practices. Any alteration or deviation from above specifications involving extra costs will become an extra charge over and above the estimate. All agreements are contingent upon strikes, accidents or delays beyond our control. Our workers are fully covered by workman's compensation insurance.
15. There will be a 15% cancellation fee on all orders cancelled after a measure has been performed. There will be a \$100 cancellation fee on all orders cancelled before the measure has been performed, plus any restocking charges from vendors.
16. This agreement contains the entire understanding between the Company and the Customer, any modifications, amendments or changes must be in writing and signed by both parties.
17. NO WARRANTY ON EXISTING EQUIPMENT, DUCT SYSTEM, UTILITIES OR ACCESSORIES NOT PROVIDED IN THIS PROPOSAL.
18. Proposals are good for thirty days. After thirty days, any parts quoted will be reevaluated for pricing.

Customer Approval: _____ **Date:** _____

6/7/23

Scott Perigo
DC West Community Schools
401 Pine St
Valley, NE 68064

Re: DC West Community Schools, 401 Pine St, Valley

Standard Heating & Air Conditioning, Inc. is pleased to quote the following:

Disconnect, remove and recycle one (1) existing 10 year old Trane packaged roof top unit #7, 20 tons cooling, 460 volt, 3-phase with economizer and hail guards.

Equipment selection is a direct replacement and no curb adapter is required.

Provide and install one (1) new **Trane** 20 ton Packaged Roof Top Unit, natural gas heat, 460 volt, 3-phase, to include economizer and smoke detector. Also included are condenser coil hail guards. Model Number YSJ240A4SOH. See included product data for detailed information.

Provide licensed electrician for connect of new units to existing line voltage.

Warranty includes one (1) year all parts and labor, with additional four (4) years on compressors.

Reconnect of existing control system to be performed by others and is not included.

Start and test system. Clean up upon completion of work.

Includes all equipment, material, fabrication, labor, utilities, permits and crane.

Estimated Delivery: 16-18 Weeks.

Thank you for the opportunity to serve your HVAC needs. Please let me know how I can be of any further service to you.

Gary Sucher
402-510-8837
garys@standardac.com



SOL LEWIS ENGINEERING COMPANY
MECHANICAL CONTRACTORS

8808 J STREET • OMAHA, NEBRASKA 68127 • PHONE 402 / 331-6171 • FAX 402 / 331-6171

6/7/2023

Douglas County West Community Schools
401 S. Pine Street PO Box 378
Valley NE 68064
Attn: Scott Perrigo

Re: RTU #7 Repair Proposal

The following proposal is to **replace the evaporator coil and short orifice metering devices (diagnosed and condemned by others) for the existing 2013 Trane 20 ton RTU (#7) at the DC West Community Schools in Valley, Nebraska, with a new OEM evaporator coil and short orifice metering devices.**

This proposal includes the following...

- > Recovery of unit refrigerant circuits.*
- > Disconnection and removal of existing coil and orifices from unit from site via crane.*
- > Installation of new Trane OEM evaporator coil and short orifice metering devices*
- > Installation of new liquid line driers.*
- > Evacuation of refrigerant circuits to 500 microns and charging of refrigerant circuits with virgin R-410A refrigerant.*
- > System startup and complete heating/cooling operations check.*
- > Removal of all excess installation material and equipment from site.*
- >Warranty of 1 year on the parts.*

This proposal includes all equipment/material/labor and crane charges necessary to complete the above-mentioned work.

BID PRICE NOT TO EXCEED \$32,476.00 (Thirty Two Thousand Four Hundred Seventy Six Dollars and 00/100)

Equipment lead time is approximately 10-12 weeks from date of order.

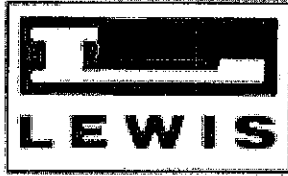

SOL LEWIS ENGINEERING COMPANY
MECHANICAL CONTRACTORS

8808 J STREET • OMAHA, NEBRASKA 68127 • PHONE 402 / 331-6171 • FAX 402 / 331-6171

6/7/2023

Douglas County West Community Schools
401 S. Pine Street PO Box 378
Valley NE 68064
Attn: Scott Perrigo

Re: RTU #7 Replacement Proposal

The following proposal is to **replace the existing 2013 Trane 20 ton RTU (#7)** at the DC West Community Schools in Valley, Nebraska, with a new **Daikin 20 ton 460v 3 phase RTU**.

This proposal includes the following...

- > *Recovery of unit refrigerant circuits.*
- > *Disconnection and removal of existing unit from site via crane.*
- > *Installation of new Daikin 20 ton RTU optioned with code required economizer/hail guards and Bac/Net control interface.*
- > *Reconnection of gas line and line voltage electrical.*
- > *Installation of new condensate trap.*
- > *System startup and complete heating/cooling operations check.*
- > *Removal of all excess installation material and equipment from site.*
- > *Both Manufacturers have warranties of 10 years on the heat exchanger, 5 years on the compressors, and 1 year on parts.*

This proposal includes all equipment/material/labor and crane charges necessary to complete the above-mentioned work.

BID PRICE NOT TO EXCEED \$41,350.00 (Forty One Thousand Three Hundred Fifty Dollars and 00/100)

Equipment lead time is approximately 10+ weeks from date of order.

All low voltage and DDC wiring and controls to be performed by others and is **NOT INCLUDED** in this proposal

*****Add \$3,795.00 to bid for YORK 20 ton RTU equivalent.**

York currently has two units in-stock at the factory for immediate delivery.

Thank you,

Ray M. Wilson
Sol Lewis Engineering Co.
402-331-6171

Accepted by _____
Date _____



Prairie Mechanical Corporation
 2842 Tucker Street
 Omaha, NE 68112-1838
 P: 402.331.4050
 F: 402.331.4078

DC WEST HIGH SCHOOL

TO:	Scott Perrigo DC West High School 401 South Pine Street Valley, NE 68064	DATE:	05/10/2023
		PHONE:	(402) 740-7611
PROJECT:	RTU-7 Evaporator and Dryer Replacement	QUOTE:	DCW05102023

Scott,

Thank you for considering Prairie Mechanical for your mechanical needs. We propose to furnish the materials and labor to perform the specific work described below for the sum of:
Twenty-Nine Thousand Three Hundred and Forty-Five Dollars..... \$29,345.00

Warranty is 1 year parts.

Scope: Replace the Evaporator coil and Factory Filter Dryers on RTU-7 as follows:

- Recover the Charge from circuit #1 and 2.
- Remove and replace the OEM system filter dryers and Evaporator Coil.
- Pressure test and Triple evacuate the system.
- Install new refrigerant.
- Startup unit and test for proper operation.
- Crane fees are included.
- Taxes (if applicable) are excluded.

Exceptions/Notes: these prices do not include replacement or repair of any other items. Pricing is based on all work being performed during regular business hours (M-F 730am-430pm). Pricing is valid for 60 days.

We thank you for the opportunity of quoting this work, and we welcome your acceptance of this proposal.

ACCEPTED BY: _____

Respectfully submitted,

PRAIRIE MECHANICAL CORPORATION
 2842 Tucker Street
 Omaha, NE 68112-1838

Date: _____

By: Jeff Casavant
Jeff Casavant 402-331-4050



Prairie Mechanical Corporation
 2842 Tucker Street
 Omaha, NE 68112-1838
 P: 402.331.4050
 F: 402.331.4078

DC WEST HIGH SCHOOL

TO:	Scott Perrigo DC West High School 401 South Pine Street Valley, NE 68064	DATE:	05/11/2023
		PHONE:	(402) 740-7611
PROJECT:	RTU-7 Replacement	QUOTE:	DCW05112023

Scott,

Thank you for considering Prairie Mechanical for your mechanical needs. We propose to furnish the materials and labor to perform the specific work described below for the sum of:
Forty-Nine Thousand Five Hundred and Fifty Dollars..... \$49,550.00
Delivery of new Unit is 30-32 Weeks.

To Substitute a York Unit With Similar Features Please Deduct \$2,300.00

Warranty is 1 Year Parts, 5 Year Compressor and 10 YR Aluminized Heat Exchanger

Scope: Replace RTU-7 With a new Trane YSJ240A Unit as follows:

- Recover the Charge from circuit #1 and 2.
- Remove and Dispose of the old unit.
- Furnish a new Trane YSJ240A RTU with Gas heat, Economizer, Comparative enthalpy and barometric relief.
- Unit has Hinged access panels, Advanced controls and LONTALK (LCI)
- Unit has factory hail guard
- Electrical and controls reconnection included.
- New unit fits existing curb.
- Startup unit and test for proper operation.
- Crane fees are included.
- Taxes (if applicable) are excluded.

Exceptions/Notes: these prices do not include replacement or repair of any other items. Pricing is based on all work being performed during regular business hours (M-F 730am-430pm). Pricing is valid for 60 days.

We thank you for the opportunity of quoting this work, and we welcome your acceptance of this proposal.

ACCEPTED BY: _____

Respectfully submitted,

PRAIRIE MECHANICAL CORPORATION
 2842 Tucker Street
 Omaha, NE 68112-1838

Date: _____

By: Jeff Casavant
 Jeff Casavant 402-331-4050



DC WEST COMMUNITY SCHOOLS

CREATING PASSIONATE LEARNERS

PO Box 378 • Valley, NE 68064 • www.dcwest.org • Ph: 402.359.2583 Fax: 402.359.4371

April 17, 2023

Dear Vendor,

DC West Community Schools Food Service is seeking bids to replace the gas convection oven and gas range or range/griddle in the middle/high school kitchen. We are seeking a bid from your company for the following equipment and installation. We also request a review of our gas infrastructure in the installed location to ensure that the equipment will work accordingly upon installation.

Vulcan gas range 36", 6 open burners model number 36C-6BN OR 36S-6BN (with casters)

OR

Vulcan gas range 36" 2 open burners and 24" griddle 36C-2B24GN OR 36S-2B24GN (with casters)

OR

Vulcan gas range 60" 4 open burners and 36" griddle 60SC-4B36GN OR 60SS-4B36GN (with casters)

AND

Vulcan gas convection oven model number VC44GD (with casters)

Please respond to our bid request with a sealed bid at the address provided by May 17, 2023.

DC West Community Schools
c/o Food Service Bid
PO Box 378
Valley, NE 68064

If you have questions regarding the bid specifications please contact Kelly Ellis, Food Service Director or Scott Perrigo, Director of Buildings and Grounds.

Thank you in advance.

Melissa Poloncic

Dr. Melissa Poloncic
Superintendent

Superintendent
Director of Learning
Director of Special Education
Elementary Principal
Middle School Principal
High School Principal
High School Assistant Principal/AD

Dr. Melissa Poloncic
Dr. Dawn Marten
Nicki Pechous
Dr. Jeffrey Kerns
Jeremy Travis
Jim Knott
Nathan Ter Beest

402.359.2583
402.359.2583
402.359.2583
402.359.2151
402.779.2646
402.359.2121
402.359.2121



Foodservice Equipment, Supplies and Design

Quote

05/09/2023

To:
 Douglas County West Comm
 Schools
 KELLY ELLIS
 401 S. PINE STR.
 VALLEY, NE 68064-9794
 402-359-4371 (Contact)

Project:
 DC WEST COMMUNITY SCHOOLS
 FOOD SERVICE PO BOX 378
 VALLEY, NE. 68064

From:
 Tyler Morgan
 Trimark Hockenbergs
 14063 Cornhusker Road
 Omaha, NE 68138
 (402)609-5153

Job Reference Number: 51965

TriMark will make best efforts to hold above prices for 30 days, however pricing may change due to manufacturer cost increases outside of TriMark's control. TriMark reserves the right to make any corrections or adjustments due to cost increases, errors, market fluctuations, supply chain disruptions, tariffs, third party supplier changes in cost or factors outside of TriMark's control. TriMark shall be permitted to increase Pricing without Customer's and /or its Franchisees consent. TriMark will provide reasonable written notice in the form of a final NSO quote to Customer and/or Franchisee at time Franchisee payment and signed quote. TriMark reserves the right to cancel or refuse any orders based on incorrect pricing or availability.

Item	Qty	Description	Sell	Sell Total
1	1 ea	RANGE, 36", 6 OPEN BURNERS Vulcan Model No. 36C-6BN Endurance™ Restaurant Range, natural gas, 36", (6) 30,000 BTU burners, lift-off burner heads, convection oven, stainless steel front, sides, backriser & lift-off high shelf, fully MIG welded chassis, 6" adjustable legs, 215,000 BTU, CSA, NSF	\$7,179.00	\$7,179.00
	1 ea	NOTE: Item qualifies for a no charge equipment check out after the unit has been fully installed & put into service. contact your Vulcan Representative for more details		
	1 ea	1 year limited parts & labor warranty, standard		
	1 ea	K-12 School Nutrition extended warranty extends the warranty for 12 months beyond the 12 month Original Equipment Warranty, not to exceed 24 months from date of installation		
	1 ea	115v/60/1-ph, cord & plug, standard		
	1 ea	Stainless steel backriser & lift-off high shelf, standard		
	1 st	CASTERS-RR4 Casters, 5" (set of 4) (2 with locks)	\$515.00	\$515.00
			ITEM TOTAL:	\$7,694.00
2	1 ea	RANGE, 36", 6 OPEN BURNERS	\$4,070.00	\$4,070.00



Item	Qty	Description	Sell	Sell Total
		Vulcan Model No. 36S-6BN Endurance™ Restaurant Range, natural gas, 36", (6) 30,000 BTU burners, lift-off burner heads, standard oven, stainless steel front, sides, backriser, & lift-off high shelf, fully MIG welded chassis, 6" adjustable legs, 215,000 BTU, CSA, NSF		
	1 ea	NOTE: Item qualifies for a no charge equipment check out after the unit has been fully installed & put into service. contact your Vulcan Representative for more details		
	1 ea	1 year limited parts & labor warranty, standard		
	1 ea	K-12 School Nutrition extended warranty extends the warranty for 12 months beyond the 12 month Original Equipment Warranty, not to exceed 24 months from date of installation		
	1 ea	Stainless steel backriser & lift-off high shelf, standard		
	1 st	CASTERS-RR4 Casters, 5" (set of 4) (2 with locks)	\$515.00	\$515.00
			ITEM TOTAL:	\$4,585.00
3	1 ea	RANGE, 36", 2 BURNERS, 24" GRIDDLE Vulcan Model No. 36C-2B24G Endurance™ Restaurant Range, gas, 36", (2) 30,000 BTU burners, (1) 24" griddle, 3/4" thick plate, lift-off burner heads, 4" W front grease trough, convection oven, stainless steel front, sides, backriser & lift-off high shelf, fully MIG welded chassis, 6" adjustable legs, 135,000 BTU, CSA Flame, CSA Star, NSF	\$10,880.00	\$10,880.00
	1 ea	NOTE: Item qualifies for a no charge equipment check out after the unit has been fully installed & put into service. contact your Vulcan Representative for more details		
	1 ea	1 year limited parts & labor warranty, standard		
	1 ea	K-12 School Nutrition extended warranty extends the warranty for 12 months beyond the 12 month Original Equipment Warranty, not to exceed 24 months from date of installation		
	1 ea	Natural gas (specify elevation if over 2,000 ft.)		
	1 ea	115v/60/1-ph, cord & plug, standard		
	1 ea	Griddle on right side, standard		
	1 ea	Stainless steel backriser & lift-off high shelf, standard		
	1 st	CASTERS-RR4 Casters, 5" (set of 4) (2 with locks)	\$515.00	\$515.00
			ITEM TOTAL:	\$11,395.00
4	1 ea	RANGE, 36", 2 BURNERS, 24" GRIDDLE Vulcan Model No. 36S-2B24G Endurance™ Restaurant Range, gas, 36", (2) 30,000 BTU burners, (1) 24" griddle, 3/4" thick plate, lift-off burner heads, standard oven, 4" W front grease trough, stainless steel front, sides, backriser & lift-off high shelf, fully MIG welded chassis, 6" adjustable legs, 135,000 BTU, CSA Flame, CSA Star, NSF	\$7,099.00	\$7,099.00
	1 ea	NOTE: Item qualifies for a no charge equipment check out after the		

Item	Qty	Description	Sell	Sell Total
		unit has been fully installed & put into service. contact your Vulcan Representative for more details		
	1 ea	1 year limited parts & labor warranty, standard		
	1 ea	K-12 School Nutrition extended warranty extends the warranty for 12 months beyond the 12 month Original Equipment Warranty, not to exceed 24 months from date of installation		
	1 ea	Natural gas (specify elevation if over 2,000 ft.)		
	1 ea	Griddle on right side, standard		
	1 ea	Stainless steel backriser & lift-off high shelf, standard		
	1 st	CASTERS-RR4 Casters, 5" (set of 4) (2 with locks)	\$515.00	\$515.00
			ITEM TOTAL:	\$7,614.00
5	1 ea	RANGE, 60", 4 BURNERS, 36" GRIDDLE Vulcan Model No. 60SC-4B36G Endurance™ Restaurant Range, gas, 60", (4) 30,000 BTU burners with lift-off burner heads, (1) 36" x 7/8" thick griddle, 4" wide front grease trough, (1) standard oven (left), (1) convection (right), stainless steel front, sides, backriser & high shelf, fully MIG welded frame, 6" adjustable legs, 238,000 BTU, CSA Flame, CSA Star, NSF	\$16,705.00	\$16,705.00
	1 ea	NOTE: Item qualifies for a no charge equipment check out after the unit has been fully installed & put into service. contact your Vulcan Representative for more details		
	1 ea	1 year limited parts & labor warranty, standard		
	1 ea	K-12 School Nutrition extended warranty extends the warranty for 12 months beyond the 12 month Original Equipment Warranty, not to exceed 24 months from date of installation		
	1 ea	Natural gas (specify elevation if over 2,000 ft.)		
	1 ea	115v/60/1-ph, cord & plug, standard		
	1 ea	Griddle on right side, standard		
	1 ea	Convection oven on right side, standard		
	1 ea	Stainless steel backriser & lift-off high shelf, standard		
	2 st	CASTERS-RR4 Casters, 5" (set of 4) (2 with locks) (quantity of 2 required)	\$515.00	\$1,030.00
			ITEM TOTAL:	\$17,735.00
6	1 ea	RANGE, 60", 4 BURNERS, 36" GRIDDLE Vulcan Model No. 60SS-4B36G Endurance™ Restaurant Range, gas, 60", (4) 30,000 BTU burners with lift-off burner heads, (1) 36" x 7/8" thick griddle, 4" wide front grease trough, (2) standard oven bases, stainless steel front, sides, backriser & high shelf, fully MIG welded frame, 6" adjustable legs, 238,000 BTU, CSA Flame, CSA Star, NSF	\$13,089.00	\$13,089.00
	1 ea	NOTE: Item qualifies for a no charge equipment check out after the unit has been fully installed & put into service. contact your Vulcan Representative for more details		

Item	Qty	Description	Sell	Sell Total
	1 ea	1 year limited parts & labor warranty, standard		
	1 ea	K-12 School Nutrition extended warranty extends the warranty for 12 months beyond the 12 month Original Equipment Warranty, not to exceed 24 months from date of installation		
	1 ea	Natural gas (specify elevation if over 2,000 ft.)		
	1 ea	Griddle on right side, standard		
	1 ea	Stainless steel backriser & lift-off high shelf, standard		
	2 st	CASTERS-RR4 Casters, 5" (set of 4) (2 with locks) (quantity of 2 required)	\$515.00	\$1,030.00
			ITEM TOTAL:	\$14,119.00
7	1 ea	CONVECTION OVEN, GAS Vulcan Model No. VC44GD Convection Oven, gas, double-deck, standard depth, solid state controls, electronic spark igniters, 60 minute timer, (5) nickel plated racks per oven, 8" high legs, stainless steel front, top & sides, stainless steel doors with windows, (2) 50,000 BTU, NSF, CSA Star, CSA Flame, ENERGY STAR®	\$12,145.00	\$12,145.00
	1 ea	NOTE: Item qualifies for a no charge equipment check out after the unit has been fully installed & put into service. contact your Vulcan Representative for more details		
	1 ea	1 year limited parts & labor warranty, standard		
	1 ea	K-12 School Nutrition extended warranty extends the warranty for 12 months beyond the 12 month Original Equipment Warranty, not to exceed 24 months from date of installation		
	1 ea	Natural gas (specify elevation if over 2,000 ft.)		
	1 ea	(2) 120v/60/1-ph, 15.4 amps total, (2) cords with plugs, standard		
	1 ea	Gas manifold piping included with stacking kit to provide single point gas connection		
	1 st	Castors, set of (4) in lieu of standard legs	\$135.00	\$135.00
			ITEM TOTAL:	\$12,280.00
8	1 ea	DELIVERY CHARGE BN Service Inc Model No. DC TRIMARK HOCKENBERGS TO DELIVER, UNCRATE, SET UP AND SET IN PLACE.	\$1,700.00	\$1,700.00
			ITEM TOTAL:	\$1,700.00
9	2 kt	BLUE HOSE GAS CONNECTOR KIT Dormont Manufacturing Model No. 1675KITS48 Packed 1 kt Dormont Blue Hose™ Moveable Gas Connector Kit, 3/4" inside dia., 48" long, covered with stainless steel braid, coated with blue antimicrobial PVC, (1) SnapFast® QD, (1) Swivel MAX®, (1) full port valve, (1) elbow, coiled restraining cable with hardware, 167,000 BTU/hr minimum flow capacity, limited lifetime warranty	\$265.00	\$530.00
			ITEM TOTAL:	\$530.00

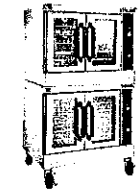

26399

7069

Item	Qty	Description	Sell	Sell Total
10	1 kt	BLUE HOSE GAS CONNECTOR KIT Dormont Manufacturing Model No. 16100KITS48 Packed 1 kt Dormont Blue Hose™ Moveable Gas Connector Kit, 1" inside dia., 48" long, covered with stainless steel braid, coated with blue antimicrobial PVC, (1) Snap Fast™ QD, (1) Swivel MAX®, (1) full port valve, (1) elbow, coiled restraining cable with hardware, 310,000 BTU/hr minimum flow capacity, limited lifetime warranty	\$355.00	\$355.00
			ITEM TOTAL:	\$355.00



11	1 ea	UTILITY CONNECTIONS Custom Model No. UC ALL FINAL UTILITY CONNECTIONS DONE BY QUALIFIED PERSONS OTHER THEN TRIMARK HOCKENBERGS AND NOT IN THIS CONTRACT.		
			Total	\$78,007.00

Standard Contract Terms & Conditions

All quotations are subject to approval by the company. The above listed prices shall be firm for 30 days. Prices shown in this quotation are for specific items, quantities, and lead times indicated.

Prices are subject to change if all of the items are not ordered, if quantities ordered differ, or if adequate lead-time is not allowed.

The prices shown in this quotation DO/DO NOT include freight charges which will be added to our invoice. This quotation does not include any fees for local permits or licenses that may be required by your municipality or state.

The prices shown in this quotation DO/DO NOT include applicable taxes, which will be added to our invoice unless a valid certificate of exemption is provided by you. Please be advised that, under state law, some items may still be taxable. In states where TriMark Hockenbergs is not registered to collect Sales Tax, it is the buyer's responsibility to pay any applicable Use Tax due to the state.

Payment terms are 50% due at time of order, 45% due prior to delivery and 5% due based on customer terms. We impose a surcharge on credit cards that is not greater than our cost of acceptance. Please be advised that a 1.5% per month FINANCE CHARGE will begin to accrue upon expiration of the above payment terms. This will amount to 18% annually.

It is our understanding that you are requesting delivery of the items on this order during the week of {T.B.D.} if this date is not correct or is missing, please provide us with a scheduled delivery date _____. If an alternative date is not provided, the date specified above is considered confirmed. In the event that the delivery date is delayed by you, or any party other than TriMark Hockenbergs, for more than two (2) weeks from the agreed upon date, you hereby agree that TriMark Hockenbergs will bill you for "stored materials".

You also agree that any payments originally due "upon delivery" will become immediately due and payable. For valuable consideration, receipt of which is hereby acknowledged, you hereby grant to TriMark Hockenbergs a security interest in the equipment described herein and any and all additions and accessories thereto, to secure payment of the total debt and any and all other obligations to TriMark Hockenbergs under this agreement. The security interest created hereby shall terminate when obligations have been paid in full.

You hereby authorize TriMark Hockenbergs to file any UCC financing statement that it deems necessary to perfect its security interest.

On capital purchases, we require a perfected security interest in the goods until they have been paid for in full. TriMark Hockenbergs will handle all of the necessary U.C.C. filings and pay for any costs associated with these filings. Upon failure of you to promptly pay or perform any of the obligations or any covenants contained or referred to herein, TriMark Hockenbergs may, at its option, declare all of the obligations immediately due and payable and then shall have all of the remedies of a secured party under the Uniform Commercial Code of the state where the equipment is located. Such remedies shall include, but are not limited to, the right to take possession of the equipment. Expenses related to repossessing, holding, repairing, or reselling the equipment, including any collection costs, reasonable attorney's fees and legal expenses, shall be the responsibility of the buyer.

No warranty of merchantability or fitness for a particular purpose, or other warranty, express, implied or statutory, nor any affirmation of fact or promise is made by Seller with respect to the goods which are sold pursuant hereto.

TRIMARK HOCKENBERGS SHALL NOT BE LIABLE FOR INCIDENTAL OR CONSEQUENTIAL LOSSES, DAMAGES OR EXPENSES, DIRECTLY OR INDIRECTLY ARISING FROM THE SALE, HANDLING OR USE OF THE GOODS, OR FROM ANY OTHER CAUSE RELATING THERETO. TriMark Hockenbergs' liability hereunder and Buyer's exclusive remedy hereunder is expressly limited to the replacement (in the form originally shipped) of goods not complying with this Agreement or, at TriMark Hockenbergs' election, to credit Buyer with an amount equal to the purchase price of such goods, whether claims are for breach of warranty, negligence or otherwise.

If you are in agreement with the aforementioned terms, prices, specifications and conditions, please sign a copy of this contract and return it to the undersigned at our offices, accompanied by any required advance payment.

Thank you for the opportunity to offer our quotation. We look forward to receiving your valued order.

TriMark Hockenbergs

Acceptance _____ Date _____

Print Name _____

Company Name _____

Acceptance: _____ Date: _____

Printed Name: _____

Project Grand Total: \$78,007.00

Quote

05/11/2023

To:
Douglas County West High School
Kelly Ellis
Valley, Ne

Project:
Douglas County West High School

From:
Buller Fixture Co.
A Division of Cash-Wa Distributing
Jeff Brayfield
6828 "L" Street
Omaha, NE 68117
Jeff.Brayfield@cashwa.com
402-592-2601 Ext 105
Cell: 402-215-1243
Fax: 402-592-0763

Job Reference Number: 2535

Item	Qty	Description	Sell	Sell Total
1	1 ea	RANGE, 36", 6 OPEN BURNERS Vulcan Model No. 36S-6BN Endurance™ Restaurant Range, natural gas, 36", (6) 30,000 BTU burners, lift-off burner heads, standard oven, stainless steel front, sides, backriser, & lift-off high shelf, fully MIG welded chassis, 6" adjustable legs, 215,000 BTU, CSA, NSF	\$4,070.00	\$4,070.00
	1 ea	1 year limited parts & labor warranty, standard		
	1 ea	Stainless steel backriser & lift-off high shelf, standard		
	1 ea	Stainless steel backriser & lift-off high shelf, standard		
	1 st	CASTERS-RR4 Casters, 5" (set of 4) (2 with locks)	\$515.00	\$515.00
			ITEM TOTAL:	\$4,585.00
2	1 ea	RANGE, 36", 2 BURNERS, 24" GRIDDLE Vulcan Model No. 36S-2B24GT Endurance™ Restaurant Range, gas, 36", (2) 30,000 BTU burners, (1) 24" griddle, 3/4" thick plate, thermostatic controls, lift-off burner heads, standard oven, 4" W front grease trough, stainless steel front, sides, backriser & lift-off high shelf, fully MIG welded chassis, 6" adjustable legs, 135,000 BTU, CSA Flame, CSA Star, NSF	\$7,676.00	\$7,676.00
	1 ea	1 year limited parts & labor warranty, standard		
	1 ea	Natural gas (specify elevation if over 2,000 ft.)		
	1 ea	Griddle on right side, standard		
	1 ea	Stainless steel backriser & lift-off high shelf, standard		
	1 ea	Stainless steel backriser & lift-off high shelf, standard		
	1 st	CASTERS-RR4 Casters, 5" (set of 4) (2 with locks)	\$515.00	\$515.00
			ITEM TOTAL:	\$8,191.00

Item	Qty	Description	Sell	Sell Total
3	1 ea	RANGE, 60", 4 BURNERS, 36" GRIDDLE Vulcan Model No. 60SS-4B36GT Endurance™ Restaurant Range, gas, 60", (4) 30,000 BTU burners with lift-off burner heads, (1) 36" x 7/8" thick griddle, thermostatic controls, 4" wide front grease trough, (2) standard oven bases, stainless steel front, sides, backriser & high shelf, fully MIG welded frame, 6" adjustable legs, 238,000 BTU, CSA Flame, CSA Star, NSF	\$13,779.00	\$13,779.00
	1 ea	1 year limited parts & labor warranty, standard		
	1 ea	Natural gas (specify elevation if over 2,000 ft.)		
	1 ea	Griddle on right side, standard		
	1 ea	Stainless steel backriser & lift-off high shelf, standard		
	2 st	CASTERS-RR4 Casters, 5" (set of 4) (2 with locks) (quantity of 2 required)	\$515.00	\$1,030.00
			ITEM TOTAL:	\$14,809.00
4	1 ea	CONVECTION OVEN, GAS Vulcan Model No. VC44GD Convection Oven, gas, double-deck, standard depth, solid state controls, electronic spark igniters, 60 minute timer, (5) nickel plated racks per oven, 8" high legs, stainless steel front, top & sides, stainless steel doors with windows, (2) 50,000 BTU, NSF, CSA Star, CSA Flame, ENERGY STAR®	\$12,144.00	\$12,144.00
	1 ea	1 year limited parts & labor warranty, standard		
	1 ea	Natural gas (specify elevation if over 2,000 ft.)		
	1 ea	(2) 120v/60/1-ph, 15.4 amps total, (2) cords with plugs, standard		
	1 ea	Gas manifold piping included with stacking kit to provide single point gas connection		
	1 st	Castors, set of (4) in lieu of standard legs	\$116.00	\$116.00
			ITEM TOTAL:	\$12,260.00
			Total	\$39,845.00



Acceptance: _____ Date: _____
 Printed Name: _____

RESTAURANT RANGES

VULCAN**ENDURANCE GAS RESTAURANT RANGE**
4 OPEN BURNERS / 36" GRIDDLE
60" WIDE GAS RANGE

Model 60SS-4B-36G-N
(shown with optional casters)

**SPECIFICATIONS**

60" wide gas restaurant range, Vulcan Model No. 60SS-4B-36G-N. Fully MIG welded aluminized steel frame for added durability. Stainless steel front, sides, backriser, highshelf and 6" adjustable legs. Extra deep crumb tray with welded corners. Four 30,000 BTU/hr. open top burners with lift-off burner heads. Energy saving flashtube open burner ignition system (one pilot for every two burners) shrouded for reliability. Heavy duty cast grates, easy lift-off 12" x 12½" in the front and 12" x 14½" in the back to better accommodate stock pots or large pans. Grates have a built in aeration bowl for greater efficiency. 36" manual griddle, 7/8" thick, 4" wide front grease trough. Burner knobs are cool to the touch, high temperature material. Two ovens: left oven is 23,000 BTU/hr. bakers depth oven, measures 26¼"d x 20¼"w x 14"h. Right oven is 35,000 BTU/hr. bakers depth oven, measures 27"d x 26⅜"w x 14"h. Oven thermostat adjusts from 250°F to 500°F with a low setting. Each oven is supplied with two racks, two rack guide sets, and four rack positions. Oven doors are heavy duty with an integrated door hinge/spring mechanism requiring no adjustment. 1" rear gas connections with rear manifold and pressure regulator. Total input 238,000 BTU/hr.

Exterior Dimensions:

34"d x 60"w x 58"h on 6" adjustable legs

- 60SS-4B-36G-N** 2 Standard Ovens / Natural Gas
- 60SS-4B-36G-P** 2 Standard Ovens / Propane
- 60SC-4B-36G-N** 1 Standard Oven / 1 Convection Oven
Natural Gas
- 60SC-4B-36G-P** 1 Standard Oven / 1 Convection Oven
Propane

STANDARD FEATURES

- Fully MIG welded frame
- Stainless steel front, sides, backriser, lift-off high shelf
- 6" stainless steel adjustable legs
- Four open top burners, each burner is 30,000 BTU/hr. with lift-off burner heads
- Shrouded flash tube pilot system (one pilot per two burners)
- Heavy duty cast grates, easy lift-off 12" x 12½" in front and 12" x 14½" in the rear
- 36" manual griddle, 7/8" thick, 4" wide front grease trough
- Extra deep pull out crumb tray with welded corners
- 23,000 BTU/hr. baker's depth oven cavity, full size sheet pans (18" x 26") fit front to back
- Oven thermostat adjusts from 250°F to 500°F
- Two oven racks and four rack positions for each oven
- Right oven: 35,000 BTU/hr. convection oven in place of standard oven 24"d x 26⅜"w x 13⅞"h (115v - 1 phase blower motor, 4 amp, 6' cord and plug, includes three oven racks. Full size sheet pans only fit side-to-side in convection oven. Convection oven motor requires field attachment.
- 1" rear gas connection and pressure regulator
- One year limited parts and labor warranty

ACCESSORIES (Packaged & Sold Separately)

- Extra oven rack with rack guides
- Casters (set of eight)
- Leveling casters (set of eight)
- Flanged feet (set of eight)
- 10" stainless steel stub back
- Reinforced high shelf for mounting salamander broiler

OPTIONS (Factory Installed)

- Thermostatically controlled griddle (snap action)

VULCAN

a division of ITW Food Equipment Group LLC



ENDURANCE GAS RESTAURANT RANGE
4 OPEN BURNERS / 36" GRIDDLE
60" WIDE GAS RANGE

INSTALLATION INSTRUCTIONS

1. A pressure regulator sized for this unit is included. Natural gas 5.0" W.C., propane gas 10.0" W.C.
2. Gas line connecting to range must be 1" or larger. If flexible connectors are used, the inside diameter must be 1" or larger.
3. An adequate ventilation system is required for commercial cooking equipment. Information may be obtained by writing to the National Fire Protection Association, 1 Batterymarch Park, Quincy, MA 02269, www.NFPA.org. When writing, refer to NFPA No. 96.
4. These units are manufactured for installation in accordance with ANSZ223.1A (latest edition), National Fuel Gas Code. Copies may be obtained from The American Gas Association, 400 N Capitol St. NW, Washington, DC 20001, www.AGA.org.

5. **Clearances**

	Rear	Sides
Combustible	6"	10"
Standard Oven Non-combustible	0"	0"
Convection Oven Non-combustible	Min. 4"	0"
6. For proper combustion, install equipment on adjustable legs or casters provided with unit.

NOTE: In line with its policy to continually improve its product, Vulcan reserves the right to change materials and specifications without notice.

Specify type of gas when ordering.
Specify altitude when above 2,000 feet.

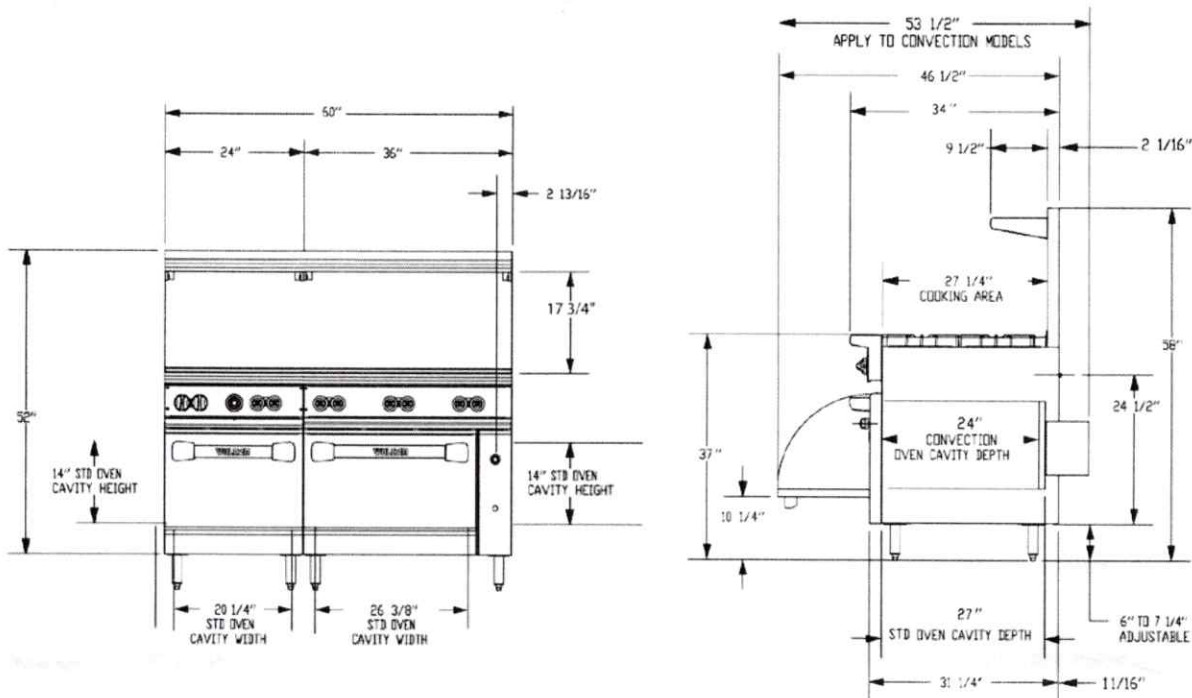

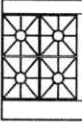
TOP CONFIGURATION	MODEL NUMBER	DESCRIPTION	TOTAL INPUT BTU / HR	SHIPPING WEIGHT LBS / KG
	60SS-4B-36G-N	2 Standard Ovens / 4 Burners / 36" Griddle / Natural Gas	238,000	1015 / 460
	60SS-4B-36G-P	2 Standard Ovens / 4 Burners / 36" Griddle / Propane	238,000	1015 / 460
	60SC-4B-36G-P	1 Standard Oven / 1 Convection Oven / 4 Burners / 36" Griddle / Natural Gas	238,000	1065 / 487
	60SC-4B-36G-P	1 Standard Oven / 1 Convection Oven / 4 Burners / 36" Griddle / Propane	238,000	1065 / 487

This appliance is manufactured for commercial use only and is not intended for home use.



a division of ITW Food Equipment Group LLC

P.O. Box 696 ■ Louisville, KY 40201 ■ Toll-free: 1-800-814-2028 ■ Local: 502-778-2791 ■ Quote & Order Fax: 1-800-444-0602

NOTE: In line with its policy to continually improve its products, Vulcan reserves the right to change materials and specifications without notice.

OVENS

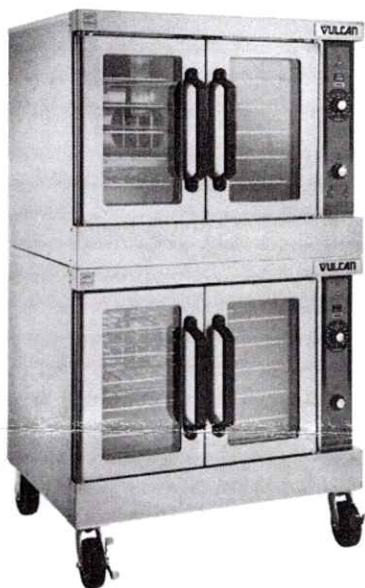
VULCAN**VC44G SERIES
DOUBLE DECK GAS CONVECTION OVENS**

Model VC44GD
shown with optional casters

**SPECIFICATIONS**

Double section gas convection oven, Vulcan-Hart Model No. (VC44GD) (VC44GC). Stainless steel front, sides, top and legs. Independently operated stainless steel doors with double pane windows. Non-sag insulation applied to the top, rear, sides, bottom and doors. Porcelain enamel on steel oven interiors measures 29"w x 22 $\frac{1}{8}$ "d x 20"h. Two interior oven lights per section. Five nickel plated oven racks per section measure 28 $\frac{1}{4}$ " x 20 $\frac{1}{2}$ ". Eleven position nickel plated rack guides with positive rack stops. One 50,000 BTU/hr. burner per section. 100,000 total BTU/hr. Electronic spark igniters. Furnished with a two speed $\frac{1}{2}$ H.P. oven blower-motor per section. Oven cool switch for rapid cool down. 120 volt, 60 Hz, 1 ph power supply required. 6' cord and plug. 7.7 amps total draw per section.

Exterior Dimensions:

40 $\frac{1}{4}$ "w x 41 $\frac{1}{8}$ "d (includes motor & door handles) 37 $\frac{3}{4}$ "d (includes motor only) x 70"h on 8" legs.

CSA design certified. NSF listed.

**SPECIFY TYPE OF GAS WHEN ORDERING.
SPECIFY ALTITUDE WHEN ABOVE 2,000 FT.**

- VC44GD** Solid state temperature controls adjust from 150° to 500°F. 60 minute timer with audible alarm.
- VC44GC** Computer controls with digital time and temperature readouts. 99-hour timer with audible alarm. Roast and Hold cycle. One hundred programmable menu selections. Shelf I.D. programming.

Double deck ovens are supplied as separate units with a stacking kit.

STANDARD FEATURES

- Stainless steel front, sides, top and legs.
- Independently operated stainless steel doors with double pane windows.
- 50,000 BTU/hr. burner per section, 100,000 BTU/hr. total.
- Electronic spark igniters.
- $\frac{1}{2}$ H.P. two speed oven blower-motor. 120/60/1 with 6' cord and plug. 7.7 amps per section. 15.4 amps total draw.
- Oven cool switch for rapid cool down.
- Porcelain enamel on steel oven interior.
- Five nickel plated oven racks with eleven rack positions per section.
- $\frac{3}{4}$ " rear gas connection with combination gas pressure regulator and safety solenoid system.
- One year limited parts and labor warranty.

OPTIONS

- Kosher friendly control package.
- Complete prison package.
 - Security screws only.
- 208V or 240V, 60 Hz, 1 ph, two speed, $\frac{1}{2}$ H.P. blower motor. 208V, 4.2 amps; 240V, 3.6 amps.
- Casters.
- Simultaneous chain driven doors.
- Control panel mounted on left side of oven.
- Stainless steel rear enclosure.
- Second year extended limited parts and labor warranty.

ACCESSORIES

- Extra oven rack(s).
- Rack hanger(s).
- Stainless steel drip pan.
- Flexible gas hose with quick disconnect and restraining device. Consult price book for available sizes.
- Down draft flue diverter for direct vent connection.

VULCAN

a division of ITW Food Equipment Group LLC



VC44G SERIES
DOUBLE DECK GAS CONVECTION OVENS

INSTALLATION INSTRUCTIONS

1. A combination gas pressure regulator and safety solenoid system is included in this unit. Natural gas is 5.0" W.C., Propane gas is 10.0" W.C.
2. An adequate ventilation system is required for commercial cooking equipment. Information may be obtained by writing to the National Fire Protection Association, Batterymarch Park, Quincy, MA 02289. When writing, refer to NFPA No. 96.
3. These units are manufactured for installation in accordance with ANSZ223.1 (latest edition), National Fuel Gas Code. Copies may be obtained from American Gas Association Inc.,

Accredited Standards Committee Z223, 400 N. Capitol St. NW, Washington, DC 20001 or the Secretary Standards Council, NFPA, 1 Batterymarch Park, Quincy, MA 02169-7471.

- | | | |
|----------------|-------------|-----------------|
| 4. Clearances: | Combustible | Non-combustible |
| Rear | 0" | 0" |
| Right Side | 2" | 0" |
| Left Side | 1" | 0" |

5. This appliance is manufactured for commercial installation only and is not intended for home use.

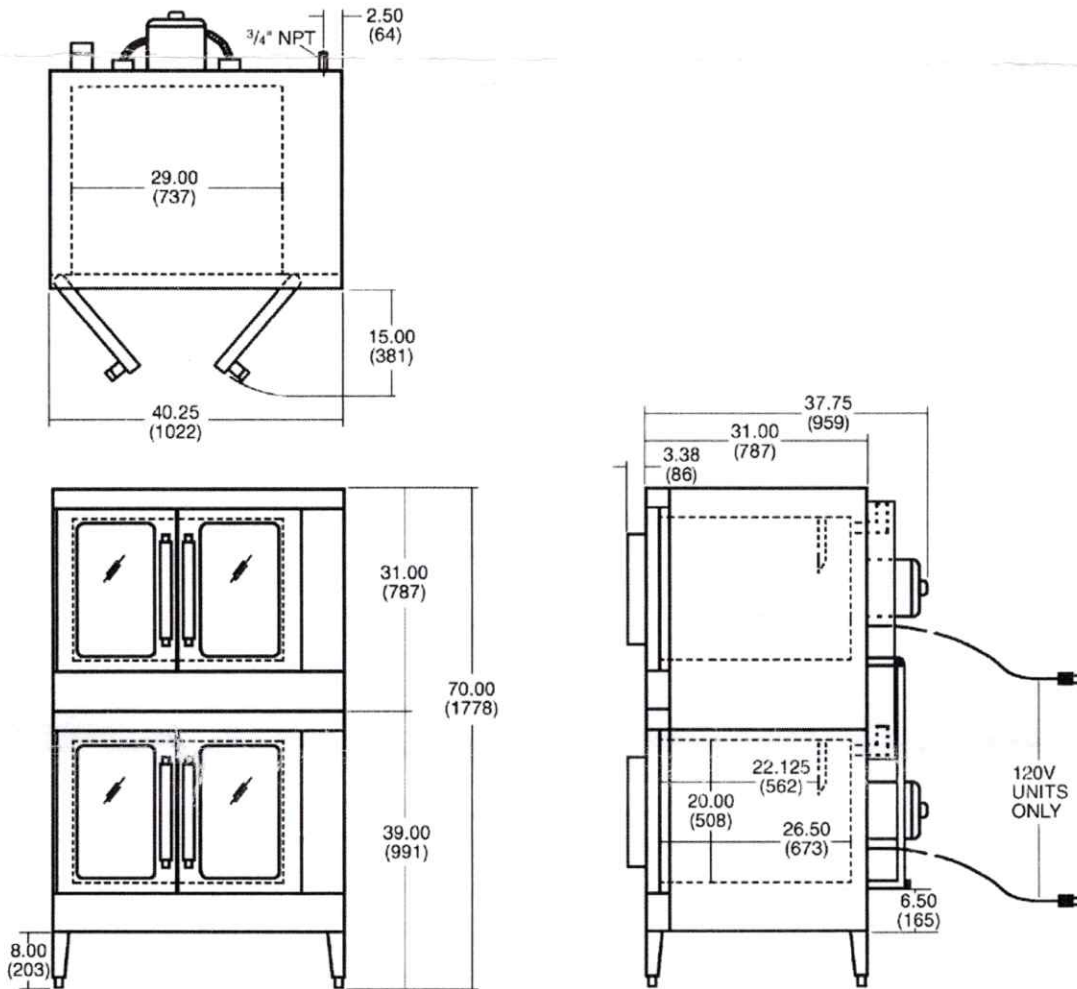

MODEL NO.	WIDTH	DEPTH (INCLUDES HANDLES)	HEIGHT	BTU/HR. PER OVEN	TOTAL BTU/HR.	ELECTRICAL	WEIGHT			
							WITH SKIDS & PACKAGING		WITHOUT SKIDS & PACKAGING	
							LBS.	KG	LBS.	KG
VC44G	40 1/4"	41 1/8"	70"	50,000	100,000	120/60/1	928	422	820	372



a division of ITW Food Equipment Group LLC

P.O. Box 696 ■ Louisville, KY 40201 ■ Toll-free: 1-800-814-2028 ■ Local: 502-778-2791 ■ Quote & Order Fax: 1-800-444-0602

NOTE: In line with its policy to continually improve its products, Vulcan reserves the right to change materials and specifications without notice.



VEHICLE PURCHASE CONTRACT

SID DILLON

SOLD TO: Dc West Community Schools STOCK # 2G23610

ADDRESS: 401 S Pine St PO Box 378 DATE 06/08/2023

CITY Valley STATE NE ZIP 68064 COUNTY Douglas

HOME PHONE (402) 504-0615 WORK PHONE CELL / E-MAIL NEW USED
DEMO

YEAR	MAKE	MODEL	BODY STYLE	COLOR	CYL.	IDENTIFICATION NUMBER	
2023	GMC	Savana	Full-size	Summit	Gas	1GJZ7NFP8P1173072	

MILES	DEL. DATE	TIME	INCENTIVE CODE	MSRP				
LEASE				\$44,775.00				
1	MONTHS	MILES	OUTRIGHT	\$44,775.00				
% SALES TAX CASH DOWN			REBATE 1					
ACQUISITION FEE INCLUDED IN PAYMENT			REBATE 2					
			REBATE 3					
			REBATE 4					
			TRADE 1					
			TRADE 2					
			SUB TOTAL	\$44,775.00				
REFERRAL <input type="checkbox"/> MEDIA <input type="checkbox"/> REPEAT <input type="checkbox"/>			OTHER					
Employee Friend or Family Member			GM CARD AUTH #					
UNLESS SPECIFIED, TAXES, LICENSE, INSURANCE AND FEES NOT INCLUDED			DOCUMENTATION FEE	\$299.00				
LIENHOLDER			OUTRIGHT/ DIFFERENCE					
ADDRESS			SERVICE AGREEMENT					
CITY STATE ZIP			GAP INSURANCE					
ACCT # PHONE #			TOTAL DEL. PRICE					
INSURANCE CO. AGENCY			CHECK # DEPOSIT					
STOCK #	YEAR	MAKE	MODEL	BODY STYLE	COLOR	CYL.	MILES	PLATE #
VIN 1	VIN 2							

TRADE(S) SUSTAINED IN EXCESS OF \$2000 DAMAGE YES NO IF YES, LOCATION OF DAMAGE AND DOLLAR AMOUNT \$ _____
 I guarantee that the title of my trade-in-vehicle(s) is not a salvage title and the vehicle never has had a salvage title. I also guarantee that neither the emissions or safety restraint system has been altered or removed. If any of this is not accurate, the selling dealer may elect to void this sale and/or elect to collect damages (including but not limited to dealer's expenses and lost profits) from me for the difference in value had my title not been salvage and/or for the cost of repair or replacement of any emissions or safety restraints.

hereby certify that: X
BUYER'S CERTIFICATION Customer Initial
 (1) The face and reverse sides of this contract set forth all of the terms and conditions of the contract; there are no other contracts or provisions, oral or written, supplementary or in addition to the provisions expressly set forth in this contract; this contract cancels and supersedes all other understandings and agreements of the parties prior to the signing hereof and as of the date hereof, when signed by the dealer, comprises the complete agreement of the parties, AND
 (2) I have read the terms and conditions of this contract and have received a true copy thereof;
 notice to Buyer: Do not sign this instrument before you read it, or, if it contains blank spaces. You are entitled to a copy of the instrument you sign. Buyer states that the amounts shown on this instrument were quoted to him before he agreed to the sale.
CUSTOMER NOTE THAT THE VEHICLE IS BEING SOLD "AS IS" BY THE SELLING DEALER. SHOULD THE MANUFACTURER'S WARRANTY APPLY TO THIS VEHICLE, IT IS DIRECTLY OFFERED BY THE MANUFACTURER TO THE CUSTOMER. THE SELLING DEALER HEREBY EXPRESSLY DISCLAIMS ALL WARRANTIES, EITHER EXPRESSED OR IMPLIED, INCLUDING ANY IMPLIED WARRANTIES OF MERCHANTABILITY OR FITNESS FOR A PARTICULAR PURPOSE, AND NEITHER ASSUMES NOR AUTHORIZES ANY OTHER PERSON TO ASSUME FOR IT ANY LIABILITY IN CONNECTION WITH THE SALE OF THIS VEHICLE. BUYER SHALL NOT BE ENTITLED TO RECOVER FROM THE SELLING DEALER ANY CONSEQUENTIAL DAMAGES, DAMAGES TO PROPERTY, DAMAGES FOR LOSS OF USE, LOSS OF TIME, LOSS OF PROFITS, OR INCOME, OR ANY OTHER INCIDENTAL DAMAGES. THIS DISCLAIMER AS TO IMPLIED WARRANTIES OF MERCHANTABILITY OR FITNESS FOR A PARTICULAR PURPOSE DOES NOT APPLY IF A SERVICE CONTRACT IS SOLD WITHIN 90 DAYS OF THE VEHICLES DATE OF SALE IN WHICH THE DEALER IS LEGALLY LIABLE UNDER THE SERVICE CONTRACT.
CONTRACTUAL DISCLOSURE STATEMENT:
 The information you see on the window form for this vehicle is part of this contract. Information on the window form overrides any contrary provisions in the contract of sale. The term "window form" refers only to the F.T.C. used car "Buyers Guide", if one is present, and not to any other form or sign that might be in any window.

SALES: _____ X _____
 ACCEPTED BY: X _____ X _____
(Dealer or his authorized representative) (Buyer's Signature)
(Co-Buyer's Signature)

The Reynolds and Reynolds Company RO618299_e Q (02/13)

THE CONTRACT CONDITIONS OF THIS ORDER ARE CONTINUED ON THE REVERSE SIDE HEREOF