

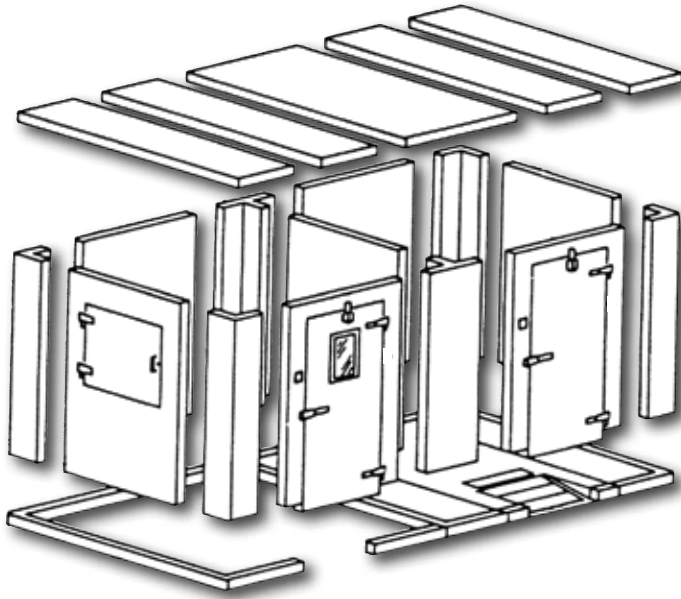

FINELINE™

Custom Walk-In Coolers & Freezers Condensed Specifications For Architects & Consultants



STANDARD FEATURES

- Coolers, freezers and combination cooler/freezers
- Modular panel construction for easy installation, expansion and relocation
- 26 gauge corrosion resistant stucco embossed coated steel
- .100 smooth aluminum interior floor (on models with floor)
- Floorless models provided with NSF approved vinyl sealers, foamed-in-place screeds or female bottom rails
- Full 4" or 5" thick panels foamed-in-place with HFO polyurethane insulation which is HFC free
- Zero ozone depletion
- Doors equipped with heavy duty polished chrome hardware
- Heavy duty, extruded, anodized aluminum load bearing door frame jamb
- Deadbolt locking handle with independent key/padlock feature and inside safety release
- High output low profile LED light positioned above the door to prevent interference with shelving or product
- Magnetic door gaskets and spring actuated door closer
- Heated pressure relief port on all freezers
- Indoor and outdoor roof and ceiling support systems
- Fifteen year panel warranty

OPTIONS & ACCESSORIES*

- Selection of interior and exterior surfaces and finishes
- Various door styles and sizes
- Wide range of computer sized and balanced refrigeration systems
- Indoor and outdoor roof and ceiling support systems
- Interior and exterior door kickplates
- Cooler and freezer door viewports
- Interior and exterior ramps
- Bumper rails, trim strips and closure panels
- Various security alarm systems
- Extra lights and special switches
- LED lighting
- Shelving (free-standing)
- Special floor underlayments and topside plating

APPROVALS

- NSF listed
- UL classified for flame spread
- UL electrical approved door section
- UL NCKL listed certifying compliant walk-ins are ignition protected
- City of Houston approved
- Oregon State approved
- State of Wisconsin Building Product approved
- USDA accepted
- Miami-Dade County, Florida Approval No. 19-0911.03, Exp. 05/10/2023 (Consult factory for requirements)
- State of Florida Product Approval File No. FL28473-R1 (Consult factory for requirements)

* Most options are available two weeks from receipt of order. Please contact us for specific questions.



SPECIFICATIONS

1.0 GENERAL

1.1 Walk-in coolers and freezers to consist of precision constructed modular 4" or 5" thick rigid polyurethane foamed-in-place interchangeable panels. Panels are designed for easy installation, expansion and relocation.

1.2 Panels shall be prefabricated modular construction consisting of 100% foamed-in-place polyurethane insulation, bonded by an adhesive to the interior and the exterior metal pan skins and heat cured for life long stability.

1.3 Each wall panel skin is to be formed using a double 90° bend on each edge to add strength and rigidity. Panels are to be in 6 inch increments, with a minimum width of 12 inches.

1.4 All panels are to bear the UL and NSF label. The panels shall incorporate cam lock type fasteners with reverse wing structural support as joining devices for the adjacent tongue and groove panels. Each device is to consist of a cam action locking arm and a steel rod in adjoining panel so that by rotating the locking arm, the hook engages over the rod and the cam action draws the panel together. The resulting panel joints shall be sealed by a foamed-in-place, continuous one piece gasket.

1.5 Panel joints are to be precisely formed male and female tongue and groove shapes fabricated to force the male edge to contact the female edge, providing additional seal. The panel joint shall have a gasket which provides a positive seal that meets NSF standards. Gasket shall be "locked" to the skins and run in a continuous piece, completely around the panel with only one break to provide the optimal seal.

2.0 INSULATION

2.1 Insulation shall be a full 4 inches or 5 inches thick, UL Class 1 rigid foamed-in-place HFO polyurethane with a minimum 2.15 lbs/cubic foot density. Foam polyurethane shall be injected into the panels by means of a high output, high impingement mixer.

2.2 The R-values for 4" HFO panels are:

Cooler:
Walls/Ceilings R-value 25
Doors R-value 25

Freezer:
Walls/Ceilings R-value 32
Doors R-value 32
Floors R-value 28

2.3 Insulation shall be 90% closed cell structure. Flame spread rating of the foam core according to ASTM E-84/UL 723 shall be 25 or less.

2.4 The use of an HFC blowing agent is specifically prohibited.

3.0 FLOOR STYLES

3.1 Less floor 4" wall walk-ins shall be supplied with PVC extruded floor sealers with semi-flexible edges, which seal to floor without the use of exposed fasteners. Sealer shall encase the wall panel on both interior and exterior surfaces with a flexible rubber collar a minimum of 3" high from finished building floor. Sealer shall meet NSF requirements for floor cove molding. Additional less floor options include female bottom rail walls for 4" and 5" thick walk-ins and various height foam sealers for 4" thick walk-ins. Consult factory for detailed specifications.

3.2 With floor walk-ins shall be a full 4 inches thick with one piece foamed-in-place edge caps. Edge caps include metal formed adhesion edges which result in the edge caps being a foamed integrated member of the floor panels. Glued-in-place edge caps are not acceptable. Floor panels shall be designed to withstand uniformly distributed loads of 800 pounds per square foot. The joint between the floor and wall shall form a NSF approved 45° angle to allow for easy cleaning.

4.0 CEILING PANELS

4.1 Ceiling panels shall be a full 4 inches or 5 inches thick with one piece foamed-in-place edge caps. Edge caps include metal formed adhesion edges which result in the edge caps being a foamed integrated member of the ceiling panels. Glued-in-place edge caps are not acceptable.

4.2 Metal face skins are to incorporate seams using a double 90° bend at a maximum width of two feet for additional strength. The joint between the ceiling and wall shall form a 45° angle to allow for easy cleaning.

5.0 FINISHES

5.1 The interior and exterior walls and interior ceiling shall be supplied with 26 gauge corrosion resistant stucco embossed coated steel. The interior floor surface (when applicable) shall be .100 smooth aluminum. Other finishes are available.

6.0 DOOR CONSTRUCTION

6.1 Entrance door shall be in fitting, flush design. The door section shall provide a full 4 inches or 5 inches of polyurethane HFO insulation, construction and finish shall be the same as the adjoining wall panels.



SPECIFICATIONS

6.2 The door shall be 4 inches thick, constructed to incorporate heavy duty, molded ABS breaker strip, which is permanently foamed-in-place. Bottom of door shall seal with double sweep gaskets, uniquely designed to provide complete seal between door, threshold, and door jamb.

6.3 Door jamb to be a fully coved, extruded, welded, structural anodized aluminum, rigid frame design for easy cleaning and maintenance.

6.4 Threshold plate provided shall be constructed of fiberglass reinforced plastic (FRP) or extruded aluminum for bearing strength. All doors shall have an anti-sweat heater wire around the entire perimeter of the door opening and under threshold.

6.5 The heater wire (standard in both coolers and freezers) shall provide enough heat to prevent condensation. All conduit for the inner-wiring of the door panel shall be totally concealed in the polyurethane foam panel, exposed conduit is not acceptable.

6.6 Door section to be field wired to surface mounted junction box on the interior door panel. The door size, location and swing to be as indicated in Specifications Drawings.

6.7 Door hardware shall be highly polished chromium plated steel. Hardware shall include a spring actuated door closer, field adjustable cam lift hinges, one spring hinge & deadbolt locking handle with independent key/padlock feature and inside safety release. All hardware shall be attached to extra large 1/2 inch thick, nonconducting synthetic tapping plates.

6.8 Digital thermometer calibrated to indicate interior walk-in temperature shall be provided with each entrance door.

6.9 High output low profile LED light with approximately twice the light output of a standard 60W incandescent or 13-15W CFL, guaranteed for 5 years or 35,000 hours. Light is positioned above the door to prevent interference with shelving or product. Locate light switch with pilot light adjacent to door, on exterior handle side of door section, with all inner wiring in conduit concealed inside the door section and terminated at a surface mounted junction box on the interior door frame. Fixture shall operate on 120 VAC.

7.0 INSTALLATION AND MAINTENANCE

7.1 Included with each walk-in shipment is a complete set of installation instructions covering all phases of panel erection, accessories, and maintenance procedures.

8.0 APPROVALS

8.1 Walk-in construction is approved by NSF International and shall have the NSF seal on the door section.

8.2 Walk-in panels shall have foam cores with a UL flame spread rating of 25.

8.3 The door section shall be UL approved as an electrically approved assembly.

8.4 City of Houston approved, Oregon State approved, State of Wisconsin Building Product approved, USDA accepted.

8.5 UL NCKL listed certifying compliant walk-ins are ignition protected.

9.0 WARRANTIES

9.1 Manufacturer shall provide a written warranty to the owner stating the product is free from defects or workmanship under normal use and service. Warranty shall become effective following the acceptance date and cover the insulated panels for a period of fifteen years and parts for a period of 18 months.

10.0 QUALITY ASSURANCE

10.1 To insure the finest quality in material and workmanship the above specifications shall be held in full compliance. Please specify the walk-in cooler or freezer is to be as manufactured by Norlake, Incorporated.

11.0 SITE CONDITIONS

11.1 To assure proper operation, site conditions should be controlled. The walk-in product should be in a well ventilated location. Indoor ambient conditions should be controlled, relative humidity between 30%-60% and maintaining a dew point of 50°F (or less).

Dedicated medium temp condensing units meet the DOE requirement of a minimum AWEF rating of 5.61 (Btu/W-h) for indoor models and 7.6 for outdoor models.

